

**2021 HYBRID RETRO BOOM  
OPERATOR'S MANUAL  
493890**





**HAGIE**  
**CONTENTS**

---

**1 – INTRODUCTION**

A Word From Hagie Manufacturing Company ..... 1-1  
About This Manual ..... 1-1  
Safety Messages Used In This Manual ..... 1-2  
Service and Assistance ..... 1-2  
Product Warranty ..... 1-2  
Identification ..... 1-2  
Specifications ..... 1-4

**2 – SAFETY AND PRECAUTIONS**

Intended Use ..... 2-1  
Safety Precautions ..... 2-1  
Safety Decals ..... 2-4

**3 – OPERATING YOUR SPRAY BOOM**

Operator's Station ..... 3-1  
Spray Booms ..... 3-6  
Fence Row Applicator ..... 3-22

**4 – MAINTENANCE AND STORAGE**

Service - Lubrication ..... 4-1  
Service - Miscellaneous ..... 4-2  
Service Intervals ..... 4-4  
Storage ..... 4-4

**5 – MISCELLANEOUS**

Transporting ..... 5-1  
Quick-Tach System - Spray Booms ..... 5-4  
Troubleshooting ..... 5-17



## SECTION 1 – INTRODUCTION

---

### A WORD FROM HAGIE MANUFACTURING COMPANY

Congratulations on the purchase of your spray boom attachment! Read this operator's manual and become familiar with operating procedures and safety precautions before attempting to operate your spray boom.

As with any piece of equipment, certain operating procedures, service, and maintenance are required to keep your spray boom in top running condition. We have attempted herein to cover all of the adjustments required to fit varying conditions. However, there may be times when special care must be considered.

*NOTE: The operator is responsible for inspecting the spray boom and having parts repaired or replaced when continued use of the product causes damage or excessive wear to other parts.*

Hagie Manufacturing Company reserves the right to make changes in the design and material of any subsequent spray boom without obligation to existing attachments.

Thank you for choosing a Hagie spray boom and we ensure you of our continued interest and support in its optimal performance for you. We are proud to have you as a customer!

### ABOUT THIS MANUAL

#### NOTICE

The purpose of this manual is to guide you in the proper operation of the spray boom attachment, as well as provide you with pertinent safety precautions and maintenance information. Refer to your sprayer operator's manual and all other literature that is included with the machine for complete instructions on machine operation.

#### NOTICE

Any pictures or illustrations contained within this manual that depict situations with shields, guards, rails, or lids removed are for demonstration only. Keep all shields and safety devices in place at all times.

This manual will aid you in the proper operation and service of your spray boom attachment. It is the responsibility of the user to read the operator's manual and comply with the correct and safe operating procedures, as well as maintain the product according to the service information provided in the *Maintenance and Storage Section* elsewhere in this manual.

Photographs and illustrations used in this manual are of general nature only. Some of the equipment described and/or shown may or may not be available on your spray boom.

Information described in this manual was correct at the time of printing. Because of Hagie Manufacturing Company's continuous product improvement, certain information

may not be included in this manual. To obtain the most current operator's manual for your attachment, please visit [www.hagie.com](http://www.hagie.com).

Keep this manual in a convenient place for easy reference. This manual is considered a permanent fixture of the product. In the event of resale, this manual must accompany the spray boom.

If you do not understand any part of this manual or require additional information or service, contact your local John Deere dealer for assistance.

---

## **SAFETY MESSAGES USED IN THIS MANUAL**

The following safety messages found throughout this manual alert you of situations that could become potentially dangerous to the operator, service personnel, or equipment.

### **DANGER**

The signal word DANGER indicates a hazardous situation which, if not avoided, will result in death or serious injury.

### **WARNING**

The signal word WARNING indicates a hazardous situation which, if not avoided, could result in death or serious injury.

### **CAUTION**

The signal word CAUTION indicates a hazardous situation which, if not avoided, could result in minor or moderate injury. CAUTION may also be used to alert against unsafe practices associated with events which could lead to personal injury.

### **NOTICE**

The signal word NOTICE indicates operator awareness which, if not avoided, may result in personal or property damage.

*NOTE: A "Note" is intended to make special mention of, or remark on.*

---

## **SERVICE AND ASSISTANCE**

Please contact your local John Deere dealer for service and assistance.

---

## **PRODUCT WARRANTY**

Please contact your local John Deere dealer for further information.

---

## **IDENTIFICATION**

### **NOTICE**

Reference to right and left-hand used throughout this manual refers to the position when seated in the operator's seat facing forward.

# SECTION 1 – INTRODUCTION



The spray booms have an identification plate mounted on the lower right-hand side of transom that provides boom model and serial number.



Spray Boom Identification Plate  
-Typical View

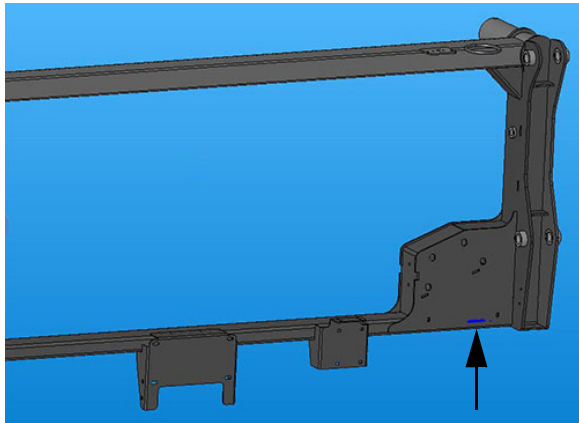

Spray Boom Identification Plate Location  
-Typical View

Serial No. \_\_\_\_\_

---

## **SPECIFICATIONS**

*NOTE: Dimensions may vary, depending on tire size.*

*NOTE: Refer to “Specifications” provided in the machine operator’s manual for complete machine and boom dimensions.*

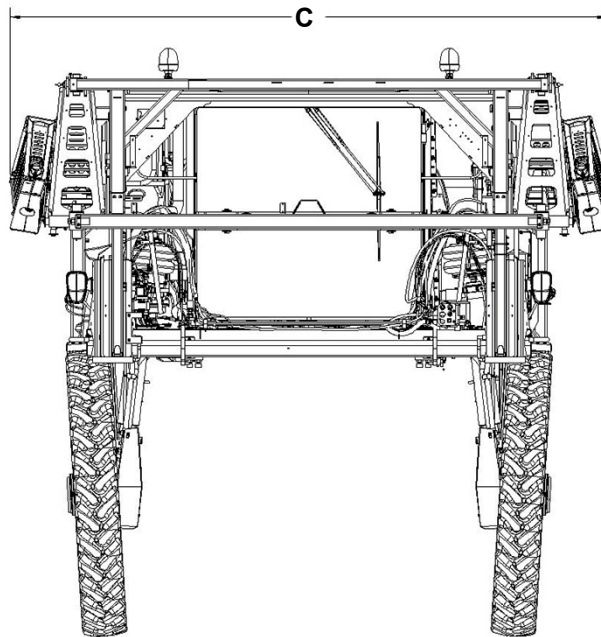
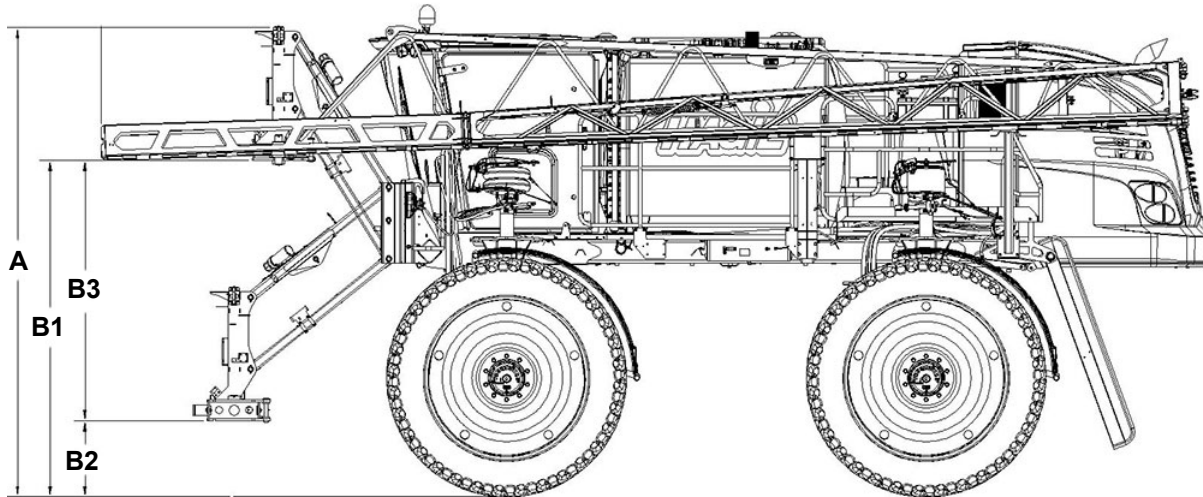

Detail	Description	Specification
A	Raised Transom Height	<ul style="list-style-type: none"> <li>• 153"/388.6 cm (from top of transom)*</li> <li>• 155.5"/395 cm (from top of solution hose)*</li> </ul>
B3	Transom Lift Range (B1 minus B2)	87" (110" - 23") 221 cm (279.4-58.4 cm)
C	Overall Width (booms folded, 120"/304.8 cm tread)	168" (426.7 cm)

*\* Refer to "Tire Specifications" provided in the machine operator's manual for a complete listing of tire options when configuring machine specifications on your model.*

<b>NOTICE</b>
<p>Because Hagie Manufacturing Company offers a variety of options, the illustrations in this manual may show a machine equipped other than standard. Machine dimension and weight values may vary, depending on available equipment.</p>

### **Boom Weight (Approximate)**

- 5,200 lbs./2,358 kg

Item	Specification
<b>General</b>	
Spray Boom	<ul style="list-style-type: none"> <li>• 120-ft.</li> <li>• 9 sections</li> </ul>
Type	1" (2.5 cm) schedule 5 stainless wet boom plumbing
Controls	Electro-hydraulic (fold/lift/level)
Level Shock Absorber	Gas charged accumulator
Inner Boom Breakaway	Hydraulic, manual reset
Outer Boom Breakaway	Mechanical with spring, auto reset
Pressure Gauge	160 PSI (11 bar), Glycerin Filled





## SECTION 1 – INTRODUCTION

Fence Row Nozzle	Remote activated (left and right)
Boom Solution Valves	Ball valves, electric actuation, stainless ball and stem, PTFE seats
<b>Electrical (Lights)</b>	
Transom	2 trapezoidal headlights
Quick-Tach Mount	2 trapezoidal headlights (high/low beam), 2 oval amber lights (combined)
Boom Cradle	2 trapezoidal floodlights (1 on each cradle), 2 oval amber lights (1 on each cradle)
Spray Boom Indicators (located on boom, if equipped)	1 oval white light, 2 oval amber lights, 9 oval red lights
Night Spray - if equipped	2 spot beam lights (1 on each main boom fold section)



## SECTION 2 – SAFETY AND PRECAUTIONS

---

### INTENDED USE

#### NOTICE

This attachment is designed for and intended to be used for the application of chemicals and fertilizers to field crops. Use in any other way or for any other purpose is considered misuse of this attachment.

Most accidents occur as the result of failure to follow basic and fundamental safety rules and precautions. Recognizing potential safety hazards, following correct and safe operating procedures described in this manual, and complying with safety warnings located throughout the machine and attachment may reduce the risk of accidents.

There is no way to completely eliminate the potential for danger when operating agricultural equipment. Therefore, you must study this operator's manual and understand how to operate the attachment controls for safe operation before using the attachment. Likewise, never let anyone operate the attachment without proper instruction.

Do not operate the attachment for anything other than its intended use. Hagie Manufacturing Company shall not be liable for any damage, injury, or death associated with improper use of the attachment.

Do not make any modifications such as, but not limited to, weldments, add-ons, adaptations, or changes from the original design of the attachment. Such modifications may become safety hazards to you and others and **will void all warranties**.

Replace missing, faded, or damaged safety signs. Refer to "Safety Decals" elsewhere in this section for correct sign and placement.

### SAFETY PRECAUTIONS

#### General Safety

- Before operating the attachment, ensure there are no obstacles or persons in the path of travel.
- The hydraulic and electrical control systems are optimized for use with this attachment. Any modification to these systems may lead to unintended or uncontrolled motion. Do NOT install add-on control systems that are not approved by Hagie Manufacturing Company.
- Some conditions cannot be completely safeguarded against without interfering with efficient operation of the machine and/or reasonable accessibility. In these cases, decals have been installed to provide the operator with hazard information. Do NOT remove decals for any reason. If a decal is damaged or missing, contact your local John Deere dealer for replacement.



#### Wear Protective Clothing

- Do not wear loose fitting clothing that could get caught in moving parts. Wear safety equipment that is appropriate for the job.



- Do not store chemical-soaked clothing in the cab. Clean off as much mud and dirt from your shoes as you can before entering the cab.

### Protect Against Noise

- Wear suitable hearing protection. Prolonged exposure to loud noise may result in loss of hearing.



### Be Prepared

- Be prepared for an emergency. Keep a fire extinguisher, first aid kit, and clean water in the cab at all times.
- Service the fire extinguisher regularly.
- Keep an accurate inventory of supplies in the first aid kit and dispose of any items that have expired.

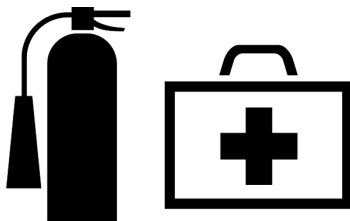

### General Repair/Maintenance Safety

- Turn off sprayer engine before checking, adjusting, repairing, lubricating, or cleaning any part of the attachment.
- Remove all chemical residue from the work area before performing service/maintenance.
- Disconnect the battery ground cable and turn the Battery Disconnect Switch OFF before servicing the electrical system or welding on an attachment.



### Remove Paint Before Welding or Heating

- Avoid toxic fumes and dust. Hazardous fumes can be generated when paint is heated by welding, soldering, or using a torch.



- Do not use chlorinated solvents in areas where welding will take place.
- Perform all work in an area that is well ventilated to carry toxic fumes and dust away.
- Dispose of paint and solvents properly.

### Avoid Heating Near Pressurized Lines

- Avoid torching, welding, and soldering near pressurized hydraulic lines. Pressurized lines may accidentally burst

when heat goes beyond the immediate flame area.



### Safe Hydraulic Maintenance

- Always practice personal safety when performing service or maintenance on the hydraulic system.
- Use caution when working around hydraulic fluid under pressure. Escaping fluid can have sufficient force to penetrate your skin, causing serious injury. This fluid may also be hot enough to burn.

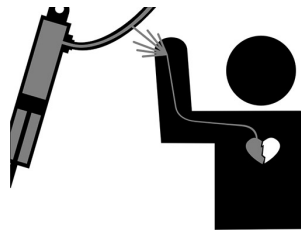

- Always lower the load or relieve pressure before repairing a hydraulic leak.

### General Spray Boom Safety

- Select a safe area before unfolding/folding the booms.
- Clear area of personnel.
- Booms must be folded and in cradles when driving the machine on a roadway or when near power lines.
- Cradle booms when leaving sprayer unattended.
- Ensure booms are folded when cradled.
- Do not unfold boom extension when main boom is in the cradle.
- Never operate the sprayer with one boom wing out of the cradle, and the other boom wing in the cradle.
- Check for overhead obstructions.
- Do not unfold or fold booms near power lines. **Contact with power lines can result in serious injury or death.**

A warning message will appear on the Machine Display before extending the outer boom extensions or when operating in Auto Fold. Press ACKNOWLEDGE showing that you have acknowledged that there are no overhead power lines or obstructions before proceeding.

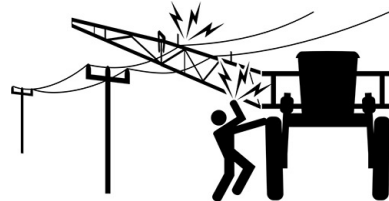

### Cold Oil Scenarios

- If the oil temperature is less than 50°F, the operator may experience control loss on the 90-ft. and 100-ft. fold cylinders. These cylinders are the main cylinders affected by over-running loads due to the weight rotation of the boom during unfold/fold situations. When the oil is cold, the valve response is not as fast or accurate. Therefore, when having to lift the weight, the cylinder will move slower, but in trying to suspend the weight, the weight may cause faster movement, as the valve is not dampening the flow like it normally would.

*NOTE: This situation requires the operator to clear area of personnel.*

### Handle Agricultural Chemicals Safely

Agricultural chemicals used in applications can be harmful to your health and the environment if not used properly.

- Always follow the manufacturer's label for directions of use.
- Never allow chemicals to come in contact with your skin or eyes. Always use the proper Personal Protective Equipment (PPE).
- Never pour chemicals into an empty solution tank. Always fill tank half full of water first.

- Dispose of empty chemical containers properly.



- Wash spilled chemicals or spray residue from the sprayer to prevent corrosion and deterioration.
- Select safe areas to fill, flush, calibrate, and clean sprayer where chemicals will not run off to contaminate people, animals, vegetation, or water supply.
- Never place a spray nozzle to your lips in an attempt to unclog it.
- Do not spray when wind is in excess of chemical manufacturer’s recommendation.
- Store chemicals in their original containers with the label intact.
- Store chemicals in a separate, locked building.
- Wear Personal Protective Equipment (PPE) as recommended by the chemical manufacturer.

## SAFETY DECALS

Decals warning you of avoidable danger are located on various parts of the attachment. They are there for your personal safety and protection. DO NOT remove them. They will fracture upon attempted removal and therefore, must be replaced.

Following are locations of important safety decals. Replace them if they are damaged or missing. All safety decals, instructional decals, or machine striping may be purchased through your local John Deere dealer.

To replace safety decals, ensure the installation area is clean and dry and decide on exact position before you remove the backing paper.

## Decal Locations

**N204628**

(Located on front left-hand cab post)



**650178**

(Located near each quick-tach lock pin assembly)

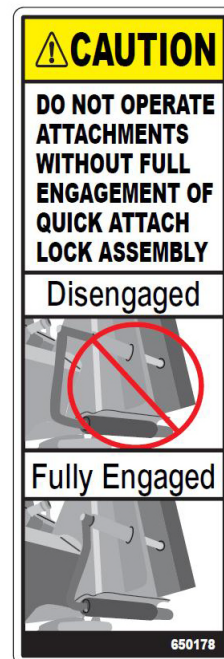

## SECTION 2 – SAFETY AND PRECAUTIONS



### HXE28534

(1) - Located on front left-hand cross member near quick connect multi-coupler

(1) - Located on inside of transom

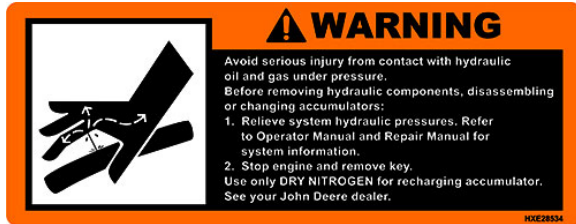

### 650204

(Located near each fold point)



### 650210

(Located on each NORAC® sensor)







## SECTION 3 – OPERATING YOUR SPRAY BOOM

### OPERATOR'S STATION

*NOTE: Refer to your machine operator's manual for a full description of cab functions and spray system operation.*

#### Side Console

- (A) - Boom Solution Valve Switches
- (B) - Fence Row Switch (Left)
- (C) - Fence Row Switch (Right)
- (D) - Boom Extension Switches (Left/Right Outer Fold)
- (E) - Transom Switch (Up/Down)
- (F) - Left-Hand Boom Switch
- (G) - Right-Hand Boom Switch
- (H) - Master Spray Switch

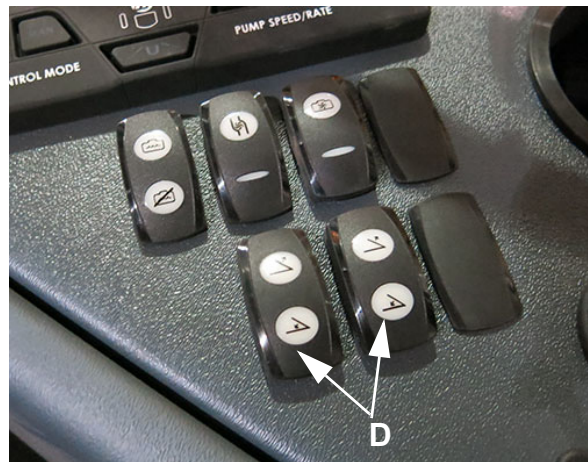

-Typical View



-Typical View



-Typical View

#### Boom Solution Valve Switches

The Boom Solution Valve Switches (located on the side console) each control a valve located on the boom or transom. The valves control the flow of the solution through the boom.

The boom is divided into sections, with the far left tip being the beginning of the first section. Each Boom Solution Valve Switch is equipped with an indicator light and will illuminate red when manually turned off.

## SECTION 3 – OPERATING YOUR SPRAY BOOM



- Press the Boom Solution Valve Switches to turn ON. Press again to turn OFF.



Boom Solution Valve Switches  
(Located on the side console)  
-Typical View

### Fence Row Switches

The Fence Row Switches (located on the side console) are used in the selection of either the right or left fence row spray nozzle.

- Press the desired Fence Row Switch (Left or Right) to turn ON. Press switch again to turn OFF.

*NOTE: The corresponding Fence Row Switch will illuminate when active.*



Fence Row Switches - Left and Right  
(Located on the side console)  
-Typical View

### Boom Extension Switches (Outer Fold)

#### **! WARNING**

When operating or positioning the booms, observe the following safety precautions to avoid serious injury or death:

- Select a safe area before folding/unfolding booms.
- Clear area of personnel.
- Check for overhead obstructions.
- Do not fold/unfold booms near power lines. Contact with power lines can result in serious injury or death.



#### **! CAUTION**

When operating or positioning the booms, observe the following safety precautions to avoid injury or equipment damage.

- Do not fold/unfold boom extensions when main boom is in cradle.
- Do not operate sprayer with one boom wing out of cradle and the other boom wing in cradle.
- Do not transport machine without booms folded and in cradle.

The Boom Extension Switches (located on the side console) are used to extend or retract the outer boom extensions.

- Press and hold the Boom Extension Switch(es) in the UP position to unfold boom extension(s) OUT.



- Press and hold the Boom Extension Switch(es) in the DOWN position to fold boom extension(s) IN.

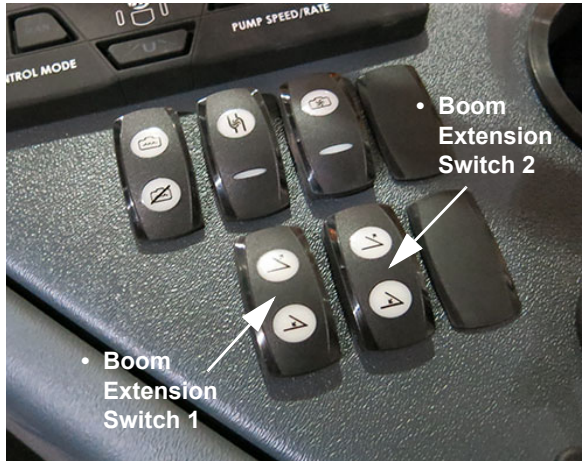

Boom Extension Switches  
(Located on the side console)  
-Typical View

### Left and Right-Hand Boom Switches

The Left and Right-Hand Boom Switches (located on the Hydrostatic Drive Control Handle) are used to raise, lower, extend, and retract the spray booms.

### Transom Switch - Up/Down

The Transom Switch (located on the Hydrostatic Drive Control Handle) is used to raise and lower the main lift.

### Master Spray Switch

The Master Spray Switch (located on the Hydrostatic Drive Control Handle) activates the boom solution valves.

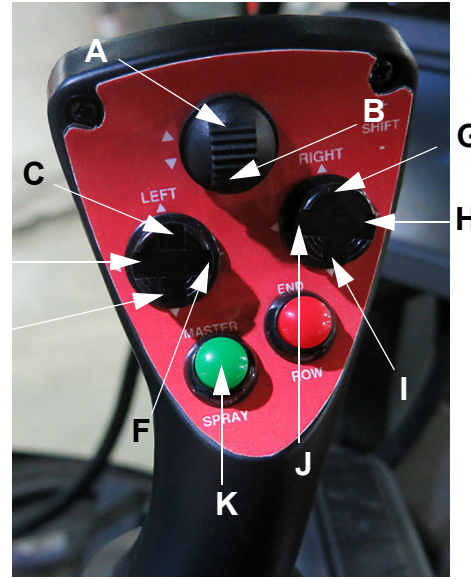

- (A) - Transom UP
- (B) - Transom DOWN
- (C) - Left Boom UP
- (D) - Left Boom OUT
- (E) - Left Boom DOWN
- (F) - Left Boom IN
- (G) - Right Boom UP
- (H) - Right Boom OUT
- (I) - Right Boom DOWN
- (J) - Right Boom IN
- (K) - Master Spray

### Overhead Monitors and Controls

- (A) - NORAC® Monitor
- (B) - Section Indicator Display
- (C) - Machine Display



-Typical View

## SECTION 3 – OPERATING YOUR SPRAY BOOM

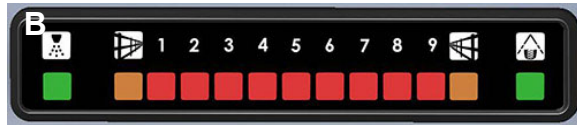

-Typical View



-Typical View

### NORAC Monitor

#### -If Equipped

The NORAC Monitor controls the automatic boom leveling system.



NORAC Monitor  
-Typical View

Refer to the manufacturer's operation manual for complete operating instructions and programming information.

### Section Indicator Display

The Section Indicator Display (located on the cab headliner) allows you to view system status for the following:

- (1) - Master Spray Indicator (illuminates when ON).
- (2) - Fence Row Indicators (illuminate when ON).

- (9) - Spray Section Indicators (illuminate when OFF).
- (1) - Rear Wheel Nozzle Indicator (illuminates when ON).

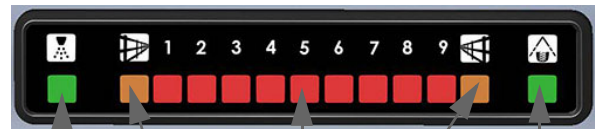

- Master Spray
- Left Fence Row
- Spray Section
- Right Fence Row
- Rear Wheel Nozzle

Section Indicator Display  
(Located on the cab headliner)  
-Typical View

### Machine Display

The Machine Display is the central control center of the machine. It controls many of the machine's electronically-driven functions, including attachment operation.



Machine Display  
-Typical View

The Machine Display also activates the Work Lights, Attachment Lights, and Night Spray Lights (if equipped).

### Work Lights

The Work Lights (located on each boom cradle) are for use when operating in the field after dark and are turned on/off through the Machine Display.





Work Lights (2)  
(Located on each boom cradle)  
-Typical View

- Press the Work Lights Button (WRK) to turn Work Lights ON. Press button again to turn Work Lights OFF.

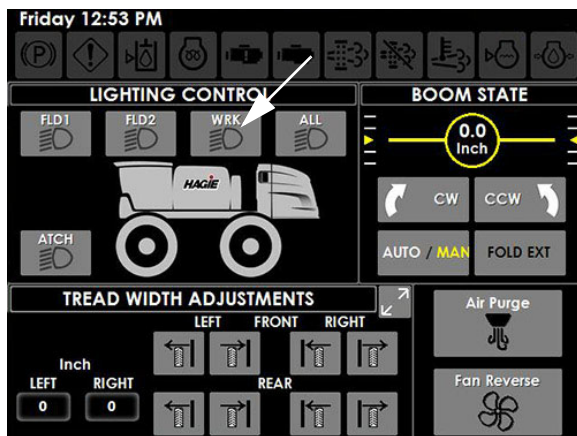

Work Lights Button  
(Located on the Machine Display  
Auxiliary Controls Page)

*NOTE: Turn Work Lights OFF before entering a public roadway.*

*NOTE: The ignition key must be in the ON position to operate the Work Lights.*

### Attachment Lights

The Attachment Lights (located on the front of transom) are for use when operating in the field after dark and are turned on/off through the Machine Display.

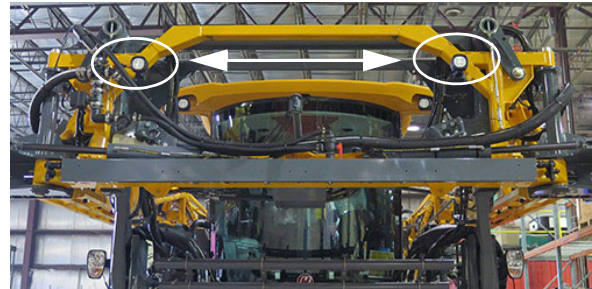

Attachment Lights (2)  
(Located on the front of transom)  
-Typical View

- Press the Attachment Lights Button (ATCH) to turn Attachment Lights ON. Press button again to turn Attachment Lights OFF.

**NOTE: The Attachment Lights Button also activates the Night Spray Lights (if equipped).**

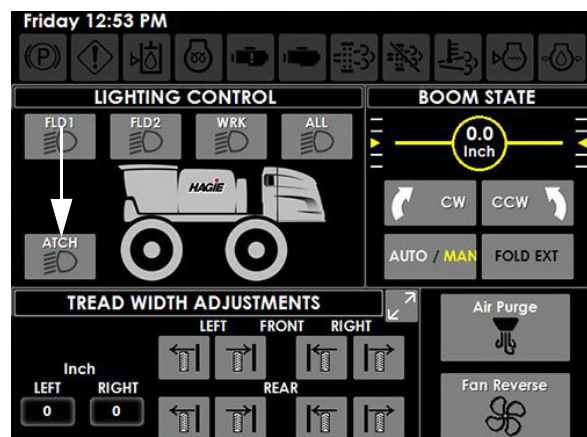

Attachment Lights Button  
(Located on the Machine Display  
Auxiliary Controls Page)

*NOTE: Turn Attachment Lights OFF before entering a public roadway.*

*NOTE: The ignition key must be in the ON position to operate the Attachment Lights.*

### Night Spray Lights

#### -If Equipped

The Night Spray Lights (located on each side of the main boom fold section) are for use when operating in the field after dark and are turned on/off through the Machine

## SECTION 3 – OPERATING YOUR SPRAY BOOM



Display. The Night Spray Lights are adjustable and may be positioned to light up the spray pattern.

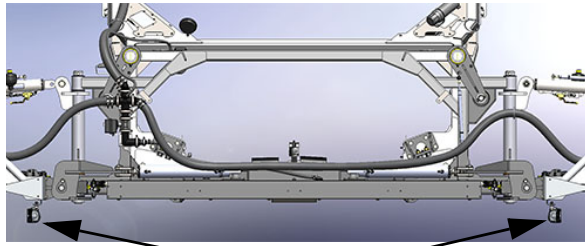

Night Spray Lights (2)  
(Located on each side of  
the main boom fold section)  
-Typical View

*NOTE: The Night Spray Lights are activated by pressing the Attachment Lights Button (ATCH) on the Machine Display Auxiliary Controls Page.*

*NOTE: The Battery Disconnect Switch (located on the rear mainframe) must be in the ON position to activate the Night Spray Lights.*

*NOTE: Turn the Night Spray Lights OFF before entering a public roadway.*

## SPRAY BOOMS

The spray booms are controlled by an electro-hydraulic system. This system consists of operator-manipulated switches (located on the side console and the hydrostatic drive control handle) and hydraulic cylinders (attached to the booms), which provide lift, level, and horizontal extension.

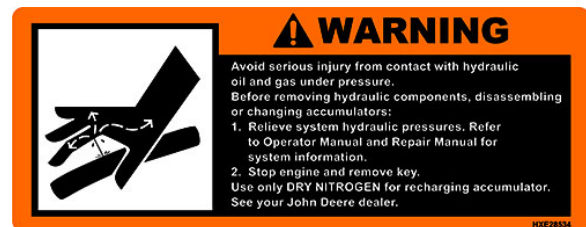

**⚠ WARNING**

When operating or positioning the booms, observe the following safety precautions:

- Monitor both sides of the boom during fold procedure.
- Cradle booms when leaving the machine unattended.
- Ensure booms are folded when cradled.
- Select a safe area before unfolding/folding the booms.
- Clear area of personnel.
- Check for overhead obstructions.
- Do not unfold/fold booms near power lines. Contact with power lines can result in serious injury or death.
- Spray equipment is designed for FIELD USE ONLY. Do not attempt to use machinery for anything other than it's intended purpose.

**⚠ WARNING**

Hydraulic and electrical control systems are optimized for use of the spray boom attachment. Any modification to these systems may lead to unintended and uncontrolled motion. **DO NOT** install add-on control systems that are not approved by Hagie Manufacturing Company.

**⚠ CAUTION**

When operating or positioning the booms, observe the following safety precautions. Failure to comply may result in injury or equipment damage.

- Do not unfold/fold boom extensions when main boom is in cradle.
- Do not operate machine with one boom wing out of cradle and the other boom wing in cradle.
- Ensure booms are folded and in cradle before transporting the machine.

**Power Lines**

Hagie Manufacturing Company cannot stress enough that extreme caution must be taken when operating equipment near power lines. Ensure there is more than sufficient clearance when transporting, unfolding and folding the boom, or spraying near power lines.



As a safety precaution, a Power Line Warning Message will appear on the Machine Display before extending the outer boom extensions or when operating in Auto Fold. Press **ACKNOWLEDGE** showing that you have acknowledged that there are no overhead power lines or obstructions before proceeding.



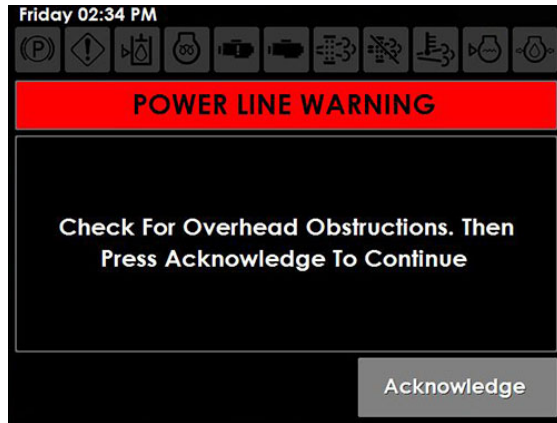

Power Line Warning Message  
(Located on the Machine Display)

Hydraulically folding the extensions of a 120-ft. spray boom and shutting off the outer section valves (Boom Solution Valve Switches 1, 2, 8, and 9) essentially turns it into a 60-ft. boom (see the following illustrations).

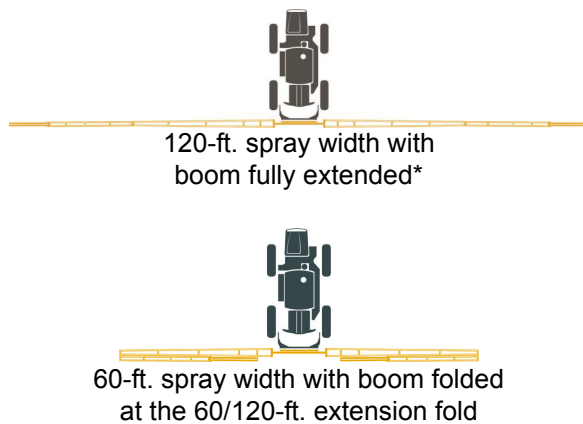

\* Recommended spray width

### Spray Boom Components

- Pivot Transom
- Fixed Transom
- Level Cylinders
- Roll Cylinders
- Outer Fold Latch Sensors
- NORAC® Sensors
- Position Sensors
- Accumulators
- Main Fold/Breakaway Cylinders
- Outer Breakaway (Tip)

### Pivot Transom

The Pivot Transom houses work lights, solution valves, main fold cylinders, and solution plumbing.



Pivot Transom  
-Typical View

### Fixed Transom

The Fixed Transom and lift arm house the lift cylinders, pressure gauge, roll lock cylinders, boom stands, fold control manifold, Hagie-installed modules, NORAC center sensor, and the NORAC lift/level hydraulic manifold.

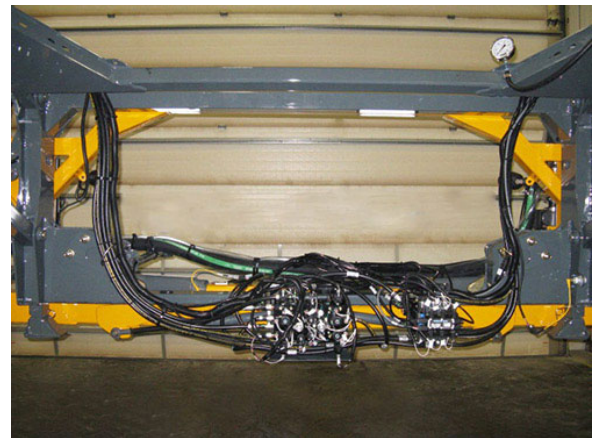

Fixed Transom  
-Typical View

### Level Cylinders

The Level Cylinders (located on each side of the transom) are responsible for the up and down movement of the boom wings when the level controls are activated.



Level Cylinder (2)  
-Typical View

### Roll Cylinders

The Roll Cylinders extend and retract, which provide the “roll” functions to aid in re-centering the boom for transport.

The Roll Cylinders are automatically placed into a “passive roll state” when the main booms are in the UNFOLDED position. This means the booms will be free to move on the pendulum assembly at this point. The hydraulic valves and cylinders will not stop this from occurring.



Roll Cylinder (2)  
-Typical View

### Outer Fold Latch Sensors

The Outer Fold Latch Sensors (two located at each outer fold section) sense if the outer fold latches are fully engaged. The sensors send a signal and alert the operator by a warning message on the Machine Display if the latches are not in the correct position.

*NOTE: The Outer Fold Latch Sensors are factory-preset and should not require calibration. Contact your local John Deere dealer if boom positioning assistance is needed.*



Outer Fold Latch Sensors (4)  
-Typical View

Refer to “Outer Fold Latches” elsewhere in this section for further information.

### NORAC Sensors

#### **CAUTION**

Placing an object beneath the NORAC Sensors when the system is in automatic mode may result in unintended movement.

The boom is equipped with five (5) NORAC Sensors (two located on each outer boom fold extension and one located on the transom) that measure boom height above ground. The sensors send a signal to the NORAC control system allowing for position corrections to keep the boom parallel to the ground and the crop, giving you a more consistent spray pattern.



## SECTION 3 – OPERATING YOUR SPRAY BOOM



NORAC Sensors (5)  
-Typical View

### Position Sensors

The level cylinders, main fold, and outer fold cylinders are equipped with internal Position Sensors. These sensors measure the linear stroke of the cylinder, allowing the boom to be positioned correctly when in Auto Fold mode.

The required specific motions exist to provide smooth, efficient operation. The programmed positions help prevent mechanical damage to the boom due to severe imbalance, unintended contact with the ground, or improper fold sequence.

*NOTE: The Position Sensors are factory-preset and should not require calibration. Contact your local John Deere dealer if boom positioning assistance is needed.*



Position Sensor (2)  
-Typical View

### Accumulators

The level cylinders (located on each side transom) are equipped with an Accumulator, which act as a “shock absorber” for the booms.



Accumulator (2)  
-Typical View

### Main Fold/Breakaway Cylinders

The Main Fold/Breakaway Cylinders are responsible for the horizontal extension of the booms to the spray position. They also provide breakaway protection for the boom. These breakaway cylinders will move backward in the event that the section encounters an obstacle.



Main Fold/Breakaway Cylinder  
-Typical View

### Outer Breakaway (Tip)

A spring breakaway (located at the tip of the boom) moves forward, backward, and up to provide protection of the boom by allowing



the boom to fold forward or backward in the event that it were to come into contact with another object.

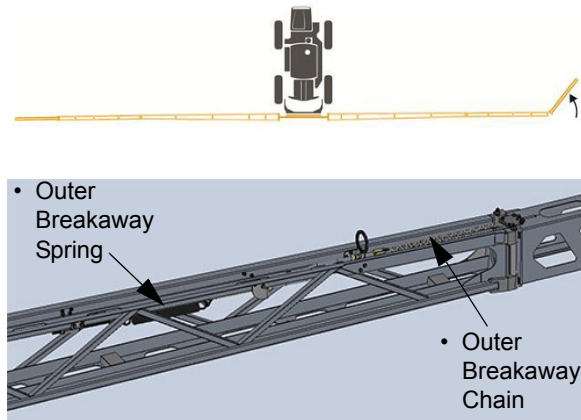

Outer Breakaway  
-Typical View

### Recharging Breakaway Circuits

#### Main Breakaway

##### To Reset the Main Breakaway

- Once the boom has broken away, press the corresponding Left or Right-Hand Boom Switch (located on the Hydrostatic Drive Control Handle) in the OUT position momentarily to stop movement and reset the hydraulic breakaway function valve (located on the main fold/breakaway cylinder).

**NOTE:** The hydraulic breakaway function breaks between 3500-4350 psi (241-299 bar).



Left and Right-Hand Boom Switches  
(Located on the Hydrostatic  
Drive Control Handle)  
-Typical View

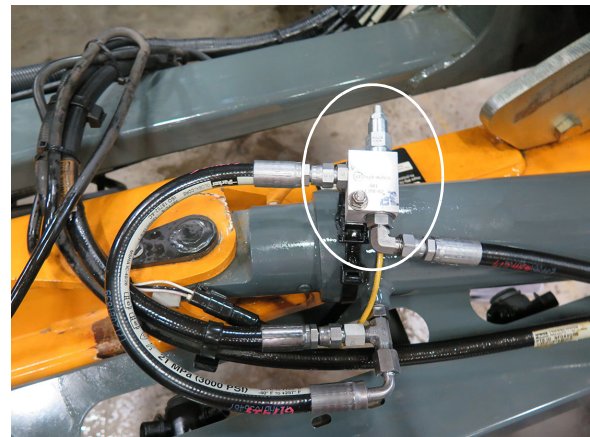

Hydraulic Breakaway Function Valve (2)  
- Main Breakaway  
(Located on each main fold/  
breakaway cylinder)  
-Typical View

- Press and hold the corresponding Left or Right-Hand Boom Switch in the OUT position until the main fold section has resumed spray position.

**NOTE:** The main boom breakaways cannot be folded unless machine speed is less than 5 mph (8 km/h).

## SECTION 3 – OPERATING YOUR SPRAY BOOM



### Outer Breakaway

The Outer Breakaway is self-resetting and will return to the normal operating position after it has cleared the hazard.

### Adjusting Breakaway Tension

**NOTE:** Recommended tension for the spring breakaway is approximately 17"/43.2 cm (distance from the first coil to the last coil, as shown in the following illustration). Settings below 17"/43.2 cm could result in breakaway hinge damage due to excessive movement during field operation. If the breakaway springs are set to 17"/43.2 cm (3.5"/8.9 cm of stretch from resting state), exerted force by the springs is 1,100 lbs./499 kg.



Spring Breakaway  
-Typical View

### To increase/decrease spring tension:

- Using a 15/16" wrench or socket, loosen the Jam Nut.
- Using a 15/16" wrench or socket, tighten the Adjust Nut to extend the spring, or loosen the Adjust Nut to retract the spring.
- Re-tighten Jam Nut.

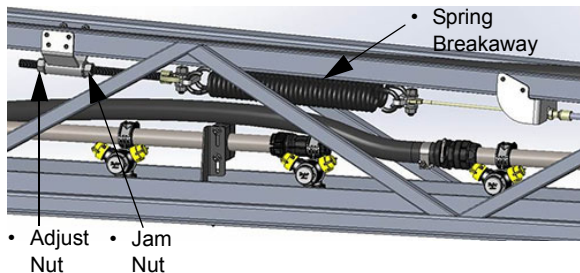

Spring Breakaway Adjust/Jam Nuts  
(Located near the outer end of the spring breakaway)  
-Typical View

### Auto Fold



The Auto Fold feature is the preferred method for folding/unfolding the spray boom and makes operation of the machine easier for the operator.

**NOTE:** Ensure the Hydrostatic Drive Control Handle is in the NEUTRAL position. If the machine is put in gear during fold operation, boom movement will stop.

1. Press the Boom State Button (located on the Machine Display Auxiliary Controls Page) to the AUTO position.

**NOTE:** The selected boom state will illuminate.

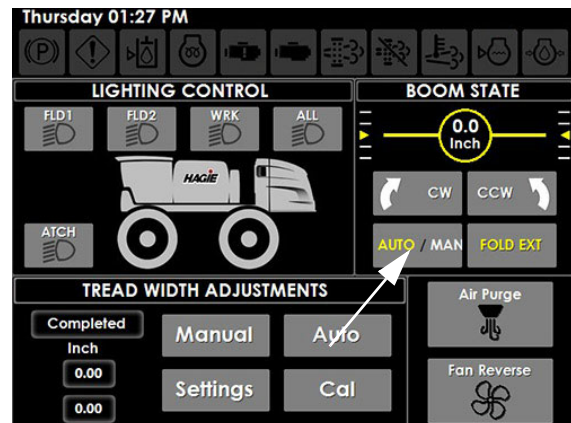

Boom State Button - Auto/Manual  
(Located on the Machine Display Auxiliary Controls Page)

2. Press the Fold Extension Button (located on the Machine Display Auxiliary Controls Page) to the ON (illuminated) position to enable Auto Fold operation of the outer boom extensions.

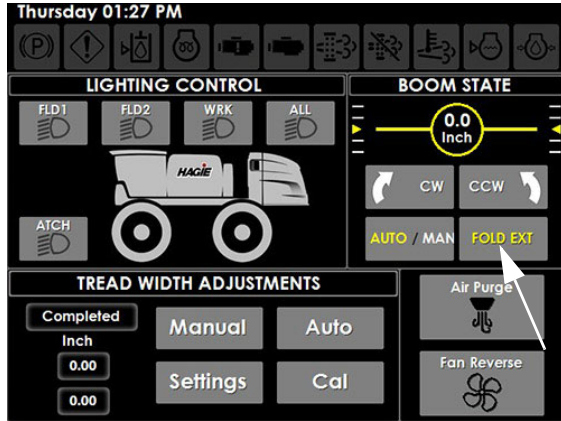

Fold Extension (Ext) Button  
(Located on the Machine Display  
Auxiliary Controls Page)

When the boom state displays AUTO and the Fold Extension Button is enabled, the boom will operate with the Boom Extension Switches (located on the side console).

*NOTE: When the Fold Extension Button is disabled, the main boom will unfold/fold, but the outer boom extensions will not.*

3. Press and hold **both** Left and Right Boom Extension Switches (located on the side console) UP to unfold the boom to the fully extended position on all sections.

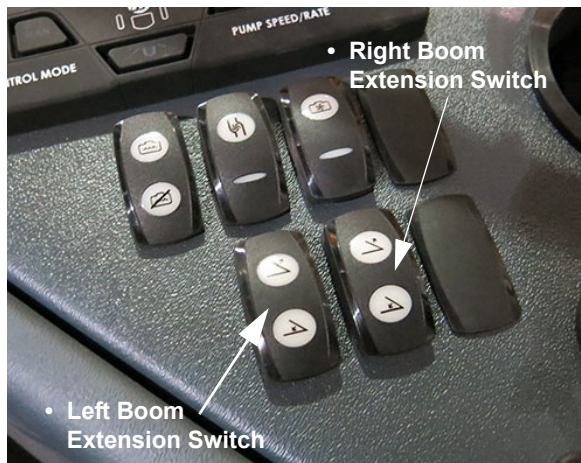

Left and Right Boom Extension Switches  
(Located on the side console)  
-Typical View

4. Press and hold **both** Left and Right Boom Extension Switches (located on

the side console) DOWN to fold the boom in to the fully retracted position.

### Manual Fold

#### NOTICE

Do not move the transom up or down during boom fold procedure. Failure to comply may result in severe damage to the boom wing structures.

#### NOTICE

Do not lower the main lift while the boom is in cradle. Failure to comply will result in property damage.



### Manual Unfold (Extend)

*NOTE: Ensure the Hydrostatic Drive Control Handle is in the NEUTRAL position. If the machine is put in gear during fold operation, boom movement will stop.*

1. Press the Boom State Button (located on the Machine Display Auxiliary Controls Page) to the MANUAL position.

*NOTE: The selected boom state will illuminate.*



## SECTION 3 – OPERATING YOUR SPRAY BOOM

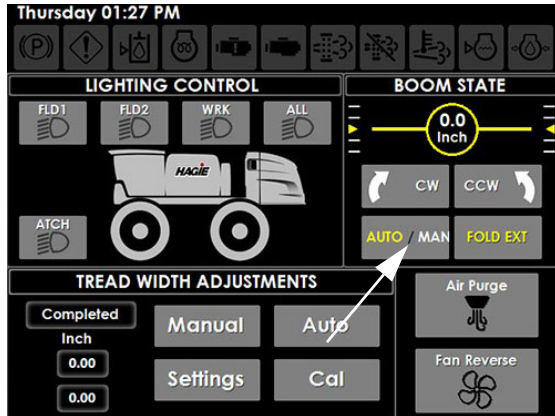

Boom State Button - Auto/Manual  
(Located on the Machine Display  
Auxiliary Controls Page)

2. Press and hold the corresponding Left and Right-Hand Boom Switches (located on the Hydrostatic Drive Control Handle) in the UP position to raise the level cylinders all the way up.

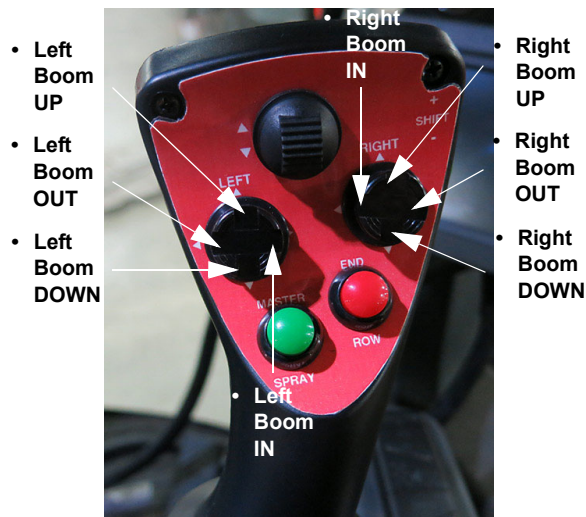

Left and Right-Hand Boom Switches  
(Located on the Hydrostatic  
Drive Control Handle)  
-Typical View

3. Press and hold the Left and Right-Hand Boom Switches in the OUT position to unfold the main boom sections until they come to a complete stop.

*NOTE: Unfold booms simultaneously to prevent weight imbalance.*

4. Lower the level cylinders until the boom is parallel with the ground.

5. Press and hold the Left and Right Boom Extension Switches (located on the side console) in the UP position to unfold the boom extensions all the way OUT.

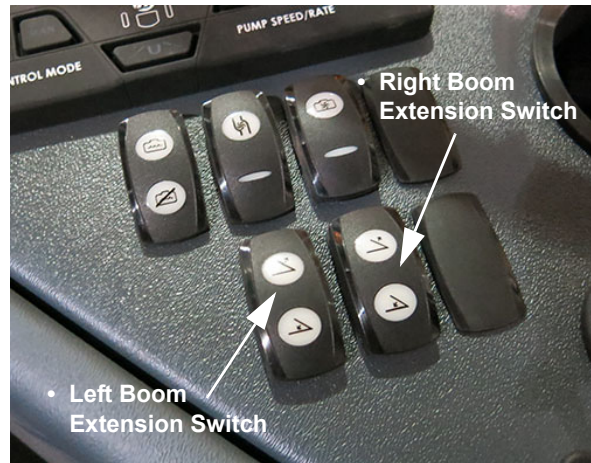

Left and Right Boom Extension Switches  
(Located on the side console)  
-Typical View

### Manual Fold (Retract)

*NOTE: Ensure the Hydrostatic Drive Control Handle is in the NEUTRAL position. If the machine is put in gear during fold operation, boom movement will stop.*

1. Press the Boom State Button (located on the Machine Display Auxiliary Controls Page) to the MANUAL position.

*NOTE: The selected boom state will illuminate.*

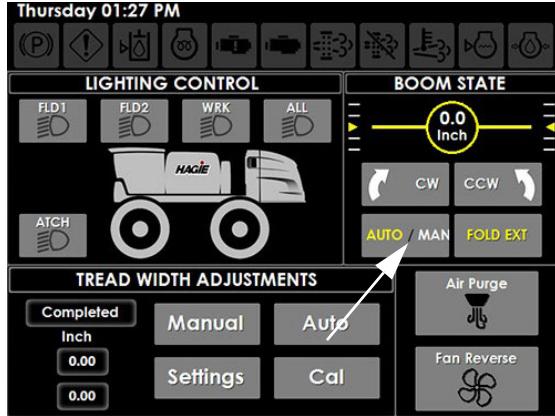

Boom State Button - Auto/Manual  
(Located on the Machine Display  
Auxiliary Controls Page)

2. Lower the level cylinders until the boom is parallel with the ground.
3. Press and hold the Left and Right Boom Extension Switches (located on the side console) in the DOWN position to fold the boom extensions all the way IN.

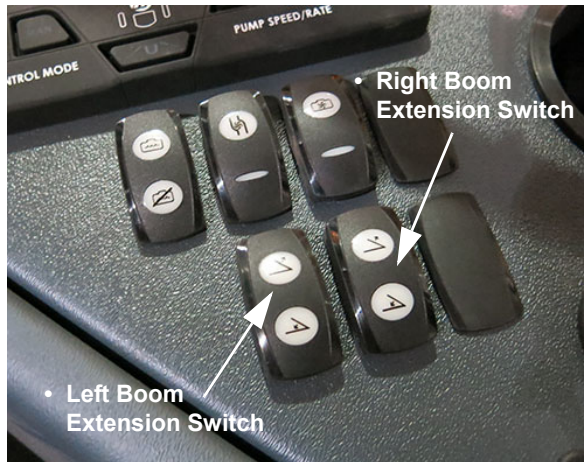

Left and Right Boom Extension Switches  
(Located on the side console)  
-Typical View

4. Raise the level cylinders all the way up.
5. Press and hold the Left and Right-Hand Boom Switches (located on the Hydrostatic Drive Control Handle) in the IN position until the main boom wings are aligned with cradles.

**NOTE:** Fold booms simultaneously to prevent weight imbalance.

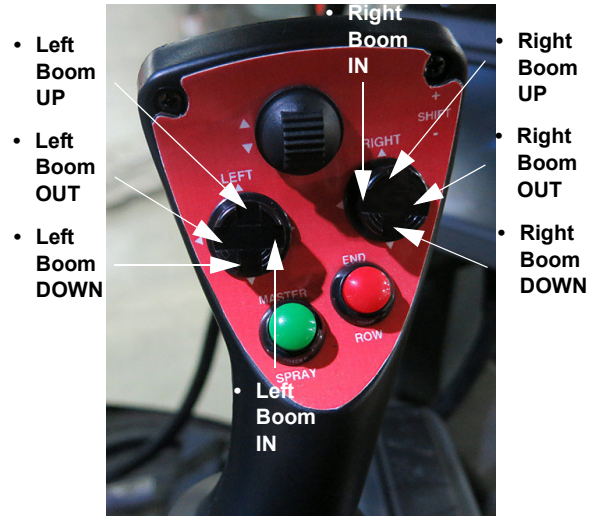

Left and Right-Hand Boom Switches  
(Located on the Hydrostatic  
Drive Control Handle)  
-Typical View

6. Lower the level cylinders until the boom sections are seated in the boom cradles.

### Boom Alignment

When operating boom functions, the Boom Alignment value may be viewed on the Machine Display Auxiliary Controls Page.

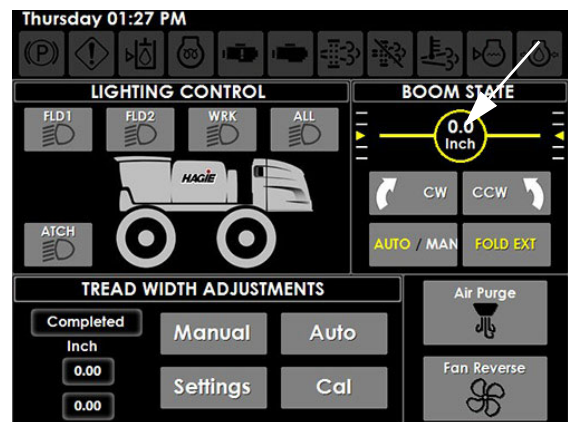

Boom Alignment Value  
(Located on the Machine Display  
Auxiliary Controls Page)

## SECTION 3 – OPERATING YOUR SPRAY BOOM



### Rolling Boom

The Rolling Boom feature will enable the boom to roll either “clockwise” or “counter-clockwise” (as viewed from the cab) using the Roll Command Buttons (located on the Machine Display Auxiliary Controls Page).

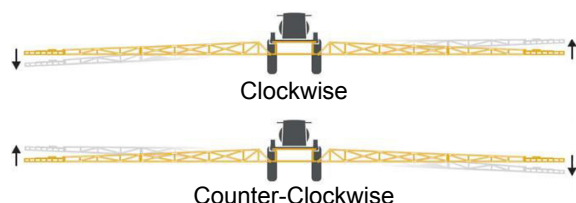

- Press and hold the “CW” Roll Command Button to roll the boom “clockwise”.
- Press and hold the “CCW” Roll Command Button to roll the boom “counter-clockwise”.

*NOTE: The Roll Command Buttons will illuminate when held in the ON position and the current boom alignment value will be displayed.*

- When either of the CW or CCW Roll Command Buttons are released, the boom will return to the neutral (center) position.

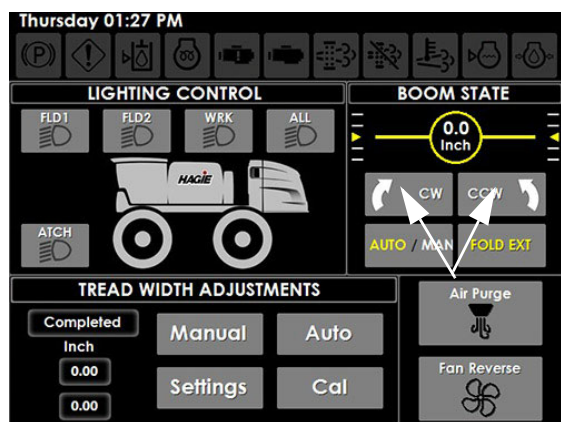

Roll Command Buttons (CW/CCW)  
(Located on the Machine Display  
Auxiliary Controls Page)

*NOTE: Center position value is 0 inches/cm.*

### Outer Fold Latches

## NOTICE

Do not operate the boom without full engagement of the outer fold latches. Failure to comply may result in severe structural damage of the attachment.

The spray boom is featured with Outer Fold Latches (located between the inner and outer boom sections on each side of attachment) to provide stronger joint structure and greatly extend the life of the boom.

Each Outer Fold Latch works in conjunction with the outer fold cylinder and hydraulic sequence valve to latch the inner and outer boom sections together after the boom is fully extended. These latches engage and disengage automatically when the outer fold extensions are extended and retracted by depressing the corresponding left and right Boom Extension Switches (located on the side console). Once the booms have fully extended, the outer wing pushes a poppet valve in the hydraulic sequence valve to extend the latch pins. This requires no additional input from the operator. Conversely, once the booms are folded again using the Boom Extension Switches, the hydraulic sequence valve retracts the latch pins before extending the outer fold cylinder to fold the boom.

*NOTE: The Outer Fold Latches operate in both manual and auto fold.*



the access hole (located near the bottom of the inner and outer boom fold) and ensure the pin is fully engaged before proceeding.

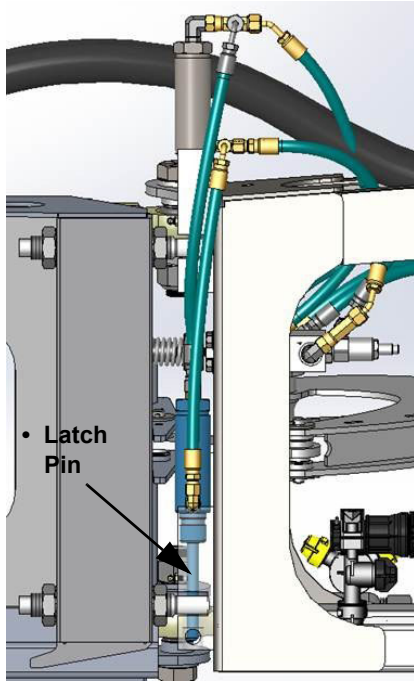

Outer Fold Latch Assembly (2)  
(Located between the inner and outer boom sections on each side of attachment)  
-Typical View

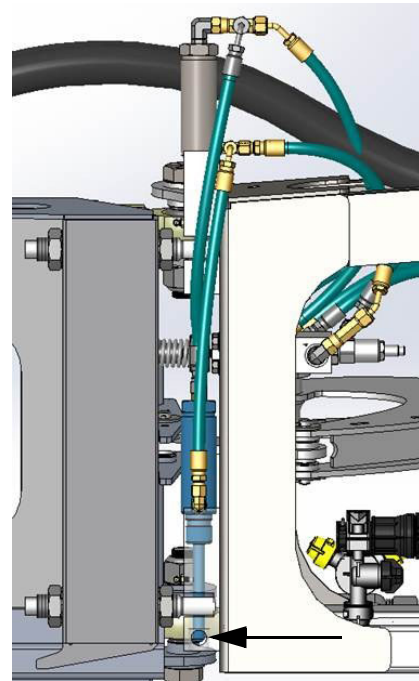

Access Hole  
(Located near the bottom of the inner and outer boom fold)  
-Typical View

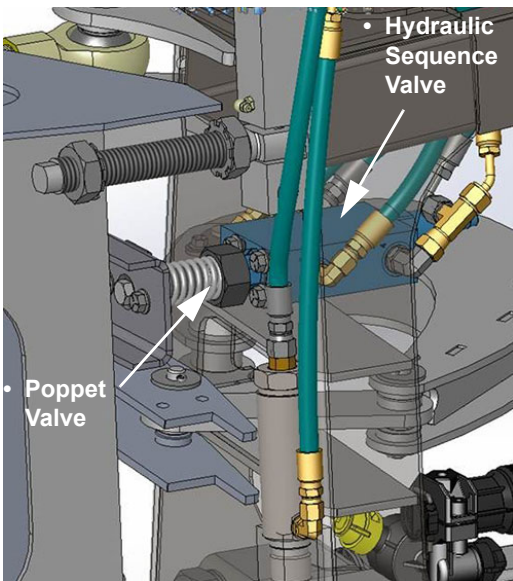

Hydraulic Sequence/Poppet Valves  
-Typical View

In the event of a latch malfunction, the operator should visually inspect the corresponding right or left latch pin through

### Transport Lock Pins

#### **⚠ WARNING**

Ensure the transport lock pins are in the “transport” (locked) position before roading or trailering the machine. Failure to comply may result in property damage, personal injury, or death.

A Transport Lock Pin assembly is installed on each side of the boom (section 2) and must be in the “transport” (locked) position to prevent unintended boom movement when roading or trailering.

## SECTION 3 – OPERATING YOUR SPRAY BOOM

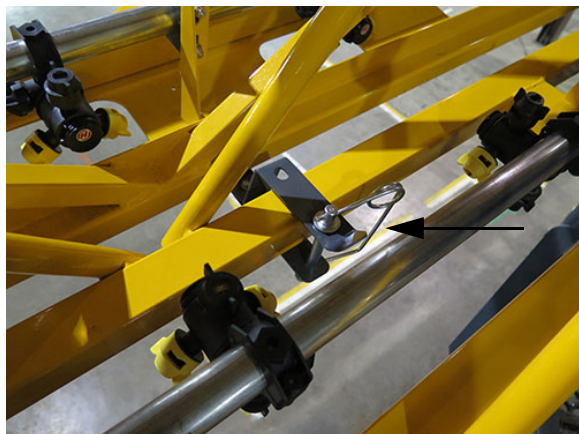

Transport Lock Pin (2)  
(Located on each side of boom - Section 2)  
-Typical View  
\* Shown in the “transport” position

Refer to “Transporting” provided in the *Miscellaneous Section* elsewhere in this manual for further information.

### Enabling/Disabling NORAC® in the Pulse Display

-If Equipped

*NOTE: Hagie Manufacturing Company recommends turning the NORAC Monitor OFF when traveling from one field to the next. A power switch is located on the back side of the monitor.*



NORAC Monitor  
-Typical View

- **To Enable**, press the corresponding Auto or Manual Button (located on the

main “Run Screen”) to the ON (green illuminated position).

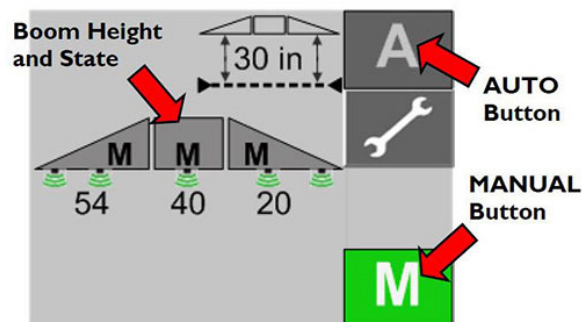

Auto/Manual Buttons - NORAC  
(Located on the main “Run Screen”)  
-Typical View

*\* Your monitor may vary in appearance, depending on model*

- **To Disable**, press the corresponding Auto or Manual Button to the OFF (gray) position or press any one of the following boom control switches (located on the Hydrostatic Drive Control Handle):
  - Transom Switch (Up/Down)
  - Left or Right-Hand Boom Switch (Up/Down)

*NOTE: If the NORAC System becomes inoperable, the Auto and Manual Fold functions will still operate.*

### Enabling/Disabling NORAC in the Ag Leader® Display

-If Equipped

- **To Enable**, press the Auto/Manual Button (located on the main “Run Screen”) to the ON (green illuminated position).

*NOTE: When the system is engaged, the boom image will change from black to blue.*





Auto/Manual Button - Ag Leader  
(Located on the main “Run Screen”)  
-Typical View

*\* Your monitor may vary in  
appearance, depending on model*

- **To Disable**, press the Auto/Manual Button to the OFF (white) position or press any one of the following boom control switches (located on the Hydrostatic Drive Control Handle):
  - Transom Switch (Up/Down)
  - Left or Right-Hand Boom Switch (Up/Down)

*NOTE: When the system is disabled, the boom image will change from blue to black.*

*NOTE: If the NORAC System becomes inoperable, the Auto and Manual Fold functions will still operate.*

### NORAC/Ag Leader System Settings

**-If Equipped  
(Soil/Crop Mode, Target Height, and Sensitivity)**

*NOTE: Settings may be adjusted through the main Run Screen by pressing the Boom Image or the Settings Button (wrench icon), depending on model. Refer to the NORAC or Ag Leader manufacturer’s operation manual for further information.*

### Soil/Crop Mode

Soil Mode allows the sensors to read the height from the spray nozzles to the ground. Crop Mode allows the sensors to read the height from the spray nozzles to the top of the crop canopy.

#### On the NORAC Pulse Monitor:

- Press the Settings Button (wrench icon) (located on the main “Run Screen”) to navigate to the Settings Screen.
- Press the Next Button (located next to “Mode”) and select Soil, Crop, or Hybrid Mode.

*NOTE: Hybrid Mode is an improved Crop Mode, which uses a combination of the crop and soil readings to improve control. This setting is recommended in place of Crop Mode.*

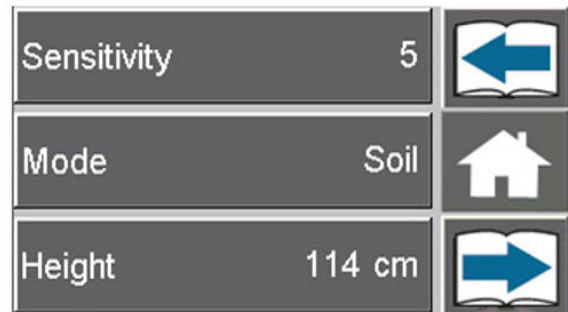

Settings Screen  
(NORAC)  
-Typical View

*\* Your monitor may vary in  
appearance, depending on model*

#### On the Ag Leader Monitor:

- Press the Boom Image (located on the main “Run Screen”).
- Press the top drop-down arrow (located on the Boom Height Control Options Screen) and select Soil or Crop Mode.

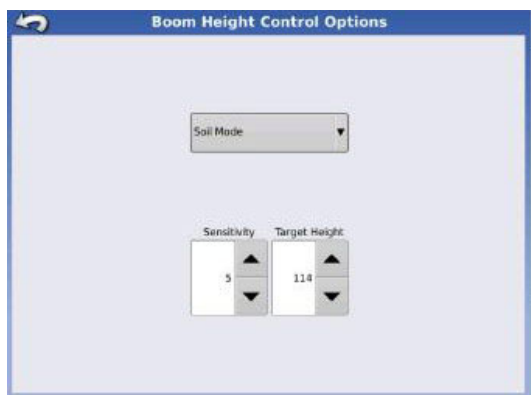

Boom Height Control Options Screen  
(Ag Leader)  
-Typical View

*\* Your monitor may vary in  
appearance, depending on model*

### Sensitivity

Sensitivity is how responsive the system is. The lower the number, the lower the sensitivity. The higher the number, the higher the response time and hydraulic demand.

*NOTE: Default sensitivity setting is 5.*

#### On the NORAC Pulse Monitor:

- Press the Settings Button (wrench icon) (located on the main “Run Screen”) to navigate to the Settings Screen.
- Press the Next Button (located next to “Sensitivity”) and increase or decrease system sensitivity values from 1-10.

#### On the Ag Leader Monitor:

- Press the Boom Image (located on the main “Run Screen”).
- Press the Sensitivity Buttons (located on the Boom Height Control Options Screen) and increase or decrease system sensitivity values from 1-10.

### Target Height

Target Height is the height you desire the boom to be set at when spraying.

*NOTE: When operating in Soil Mode, the Target Height is measured from the spray nozzles to the soil. In Crop Mode, the target height is measured from the crop canopy to the spray nozzles.*

#### On the NORAC Pulse Monitor:

- Press the Settings Button (wrench icon) (located on the main “Run Screen”) to navigate to the Settings Screen.
- Press the Next Button (located next to “Height”) and increase or decrease values to desired boom height.

#### On the Ag Leader Monitor:

- Press the Boom Image (located on the main “Run Screen”).
- Press the Target Height Buttons (located on the Boom Height Control Options Screen) and increase or decrease values to desired boom height.

### Further Information

Refer to the NORAC or Ag Leader manufacturer’s operation manual for complete operating/calibration instructions, troubleshooting information, and safety precautions.

Refer to “Specifications” provided in the *Introduction Section* of your machine operator’s manual for information on GPS dimensions on your machine.

### Enabling NORAC through the End Row Management Switch

**-If Equipped**  
*(Typical View - appearance may vary,  
depending on model)*

1. Program the End Row Management Switch (located on the Hydrostatic Drive Control Handle) through the Machine Display.  
Refer to “Machine Display” provided in the *Cab Section* of your machine operator’s manual for initial setup instructions.



End Row Management Switch  
(Located on the Hydrostatic  
Drive Control Handle)  
-Typical View

2. On the NORAC or Ag Leader main “Run Screen”, press the “wrench” icon.



Main Run Screen  
-Typical View

3. On the Settings Screen (1/3), press the “right/forward” blue arrow icon to navigate to the next screen.

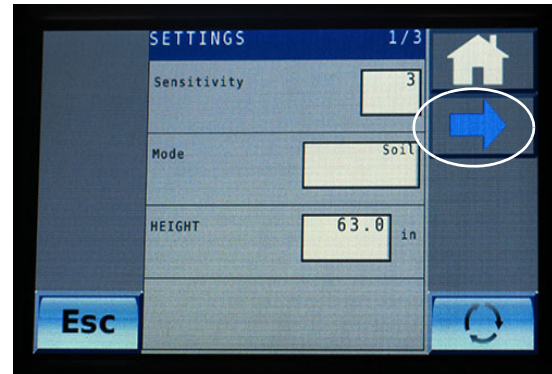

Settings Screen (1/3)  
-Typical View

4. On the Settings Screen (2/3), press the “right/forward” blue arrow icon to navigate to the next screen.
5. On the Settings Screen (3/3), press the “check page” icon.



Settings Screen (3/3)  
-Typical View

6. On the Options Screen (1/5), ensure the “Remote Switches” option is selected and press the “right/forward” blue arrow icon to navigate to the next screen.



## SECTION 3 – OPERATING YOUR SPRAY BOOM

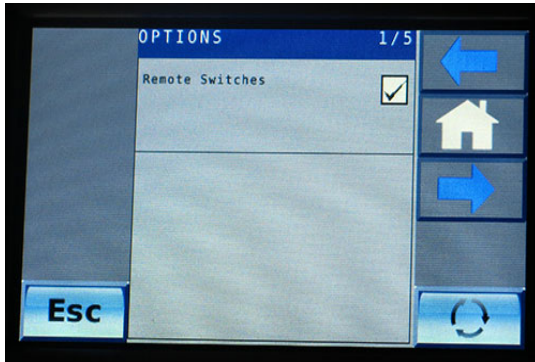

Options Screen (1/5)  
-Typical View

- On the Options Screen (2/5), select “Headland Assist”.

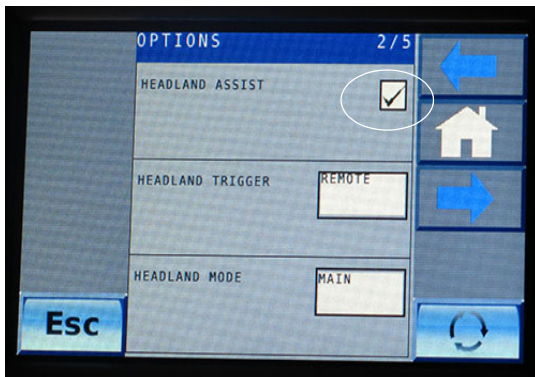

Options Screen (2/5)  
-Typical View

- On the Options Screen (2/5), press the selection area (next to “Headland Trigger”) and select REMOTE to enable NORAC through the End Row Management Switch.

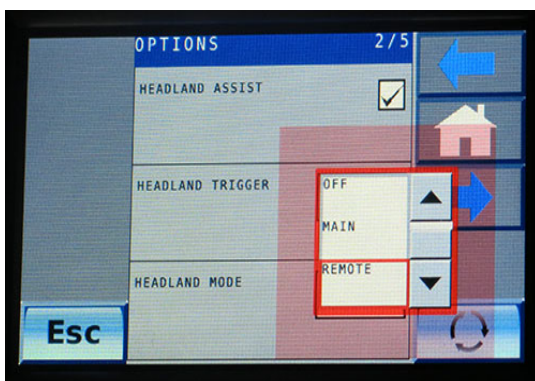

Options Screen (2/5)  
-Typical View

- On the Options Screen (2/5), press the selection area (next to “Headland Mode”) and select MAIN or WINGS.

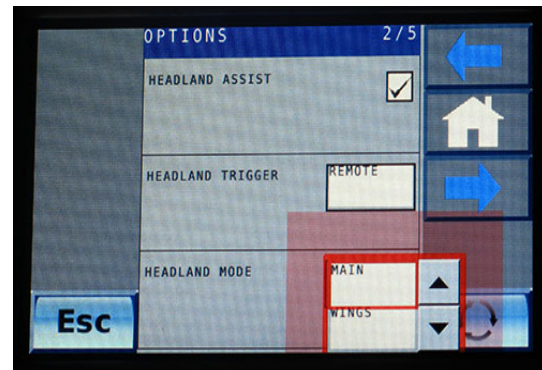

Options Screen (2/5)  
-Typical View

## FENCE ROW APPLICATOR

### To Operate the Fence Row Nozzles

*NOTE: Boom Solution Valves 1 or 9 must be in the ON position in order to enable the Fence Row Switches.*

- Press the desired Fence Row Switch - Left or Right (located on the side console) to turn ON. Press switch again to turn OFF.

*NOTE: The corresponding Fence Row Switch will illuminate when active.*



Fence Row Switches - Left and Right  
(Located on the side console)  
-Typical View

### To Operate the Rear Nozzles

*NOTE: The center section of the boom must be in the ON position in order to enable the Rear Nozzles.*

*NOTE: The rear track nozzle is only activated if the Rear Nozzle Switch is depressed and Section 5 is ON.*

The Rear Nozzle Switch (located on the side console) controls the two (2) rear nozzles (located behind the tires).

- Press the Rear Nozzle Switch to turn ON. Press switch again to turn OFF.

*NOTE: The Rear Nozzle Switch will illuminate when active.*

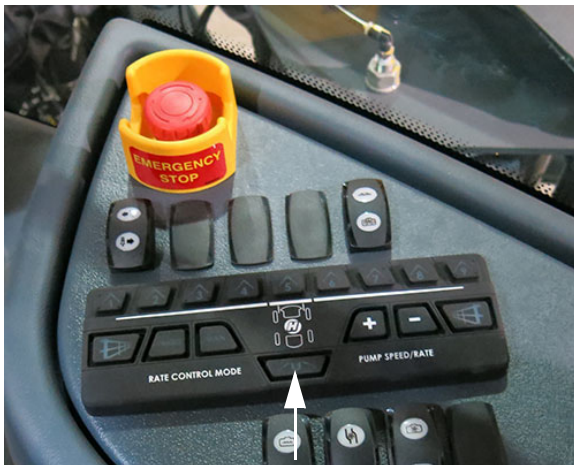

Rear Nozzle Switch  
(Located on the side console)  
-Typical View



## SECTION 4 – MAINTENANCE AND STORAGE

### SERVICE - LUBRICATION

#### NOTICE

Failure to properly lubricate pivot and friction points may result in unnecessary wear and damage.

#### Spray Booms

##### Outer Fold Cylinder

Lubricate the Outer Fold Cylinder Grease Zerks (one per side) weekly, or as needed.

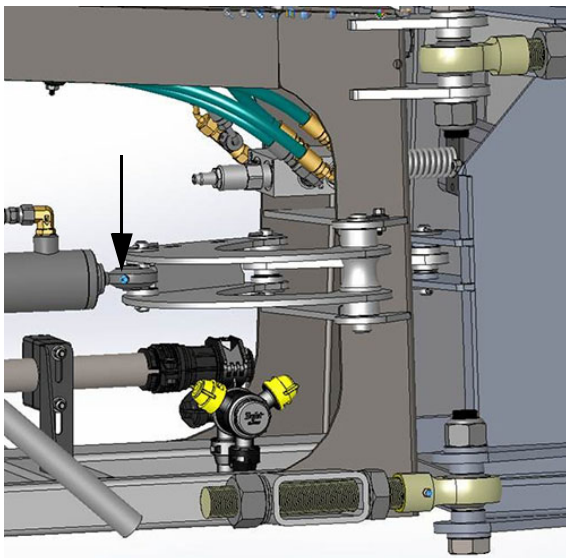

Outer Fold Cylinder Grease Zerk (2)  
-Typical View

##### Outer Fold Joint (Top/Bottom)

Lubricate the Outer Fold Joint Grease Zerks - Top/Bottom (two per side) weekly, or as needed.

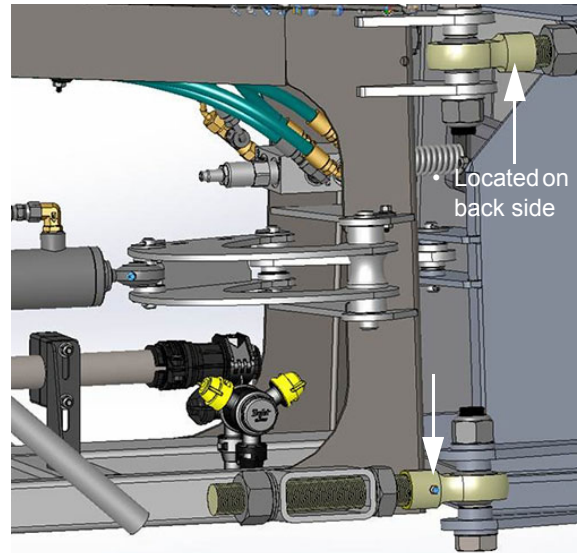

Outer Fold Joint Grease Zerks (4)  
(Top/Bottom)  
-Typical View

##### Main Fold Pivot (Upper/Lower)

Lubricate the Main Fold Pivot Grease Zerks - Upper/Lower (two per side) weekly, or as needed.

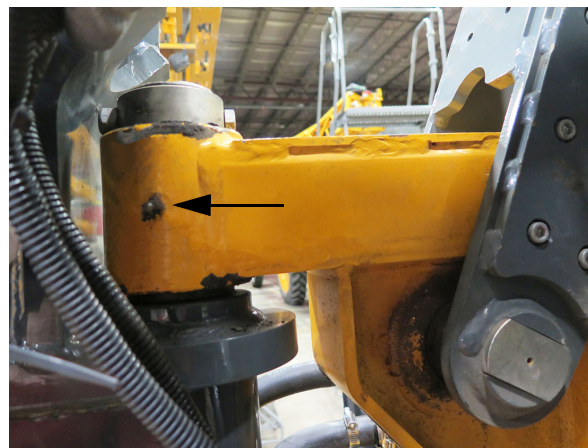

Main Fold Pivot Grease Zerk - Upper (2)  
-Typical View



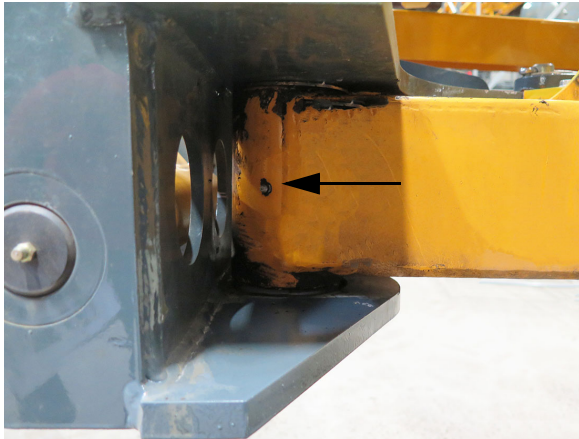

Main Fold Pivot Grease Zerk - Lower (2)  
-Typical View

### Level Pin

Lubricate the Level Pin Grease Zerks (two per side) weekly, or as needed.

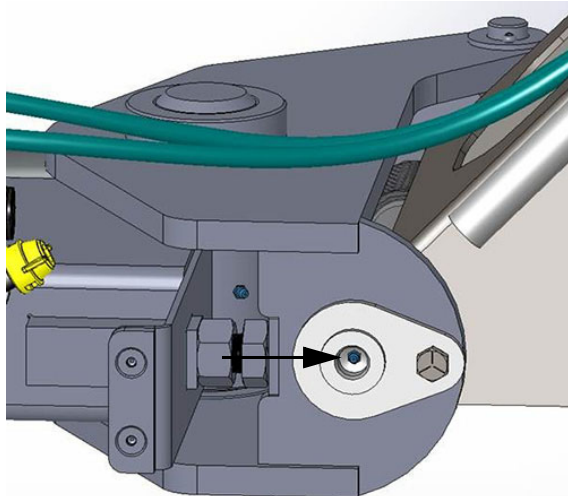

Level Pin Grease Zerk (4)  
-Typical View

### Outer Fold Latches

Lubricate the Outer Fold Latch Grease Zerks - Top/Bottom (two per side) weekly, or as needed.

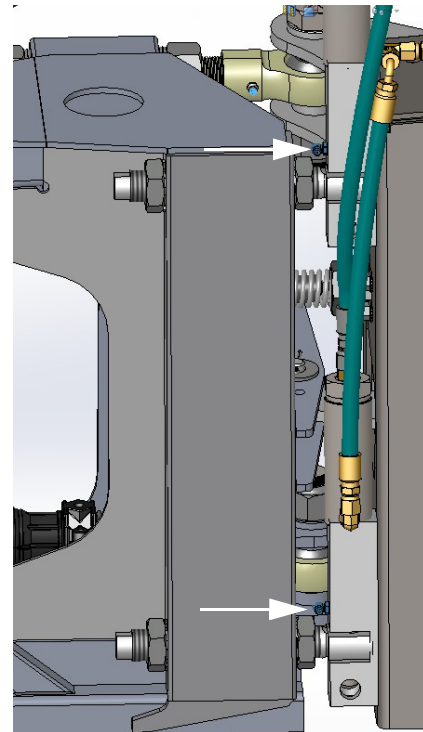

Outer Fold Latch Grease Zerks (4)  
(Top/Bottom)  
-Typical View

---

## SERVICE - MISCELLANEOUS

### Spray Booms

#### Nozzle Diaphragms

At the beginning of each season, remove each nozzle body cap (A) and inspect the diaphragm (B) for wear or fit. Replace diaphragms every 1,000 hours of operation, or as necessary.

#### Spray Tips

## CAUTION

Never place a spray tip/nozzle to your mouth in an attempt to unplug it.

## SECTION 4 – MAINTENANCE AND STORAGE



At the beginning of each season (or as required), remove a random sample of spray tip caps (C) and inspect the nozzle tips. If the tips are plugged or worn, clean or replace them. Replace spray tips every 1,000 hours of operation, or as necessary.

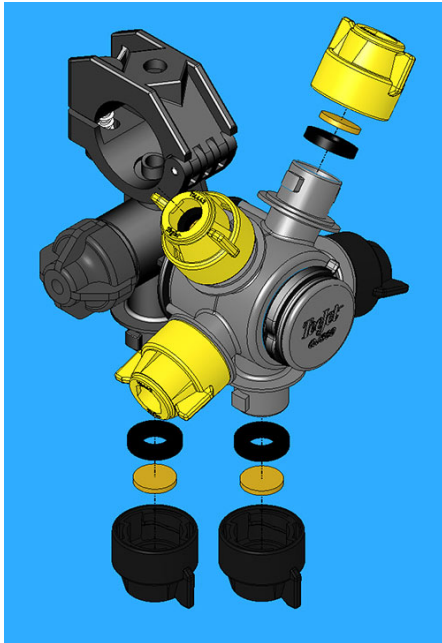

Nozzle Diaphragms and Spray Tips  
-Typical View



**SERVICE INTERVALS**

120' Hybrid Spray Boom Service Intervals				
Service Point	Daily/ Before Each Use	Weekly	As Required	1000 Hrs.
Lubricate Outer Fold Cylinder Grease Zerks		X		
Lubricate Outer Fold Joint Grease Zerks		X		
Lubricate Main Fold Pivot Grease Zerks		X		
Lubricate Level Pin Grease Zerks		X		
Lubricate Outer Fold Latch Grease Zerks		X		
Check Spray Nozzle Diaphragms and Tips			X	
Change Spray Nozzle Diaphragms and Tips				X

**STORAGE**

**Preparing For Storage**

1. Perform daily and weekly lubrication and maintenance inspections, as required.
2. With the engine at normal operating temperature, cycle all the hydraulic functions.
3. Thoroughly rinse the spray system.

*NOTE: Refer to your machine operator's manual for further information.*

4. Thoroughly wash the attachment and touch up any chipped or damaged paint.
5. Replace any damaged or missing decals.

*NOTE: Contact your local John Deere dealer for paint touch-up recommendations and decal replacement.*

6. Apply multi-purpose grease to hydraulic cylinder rods.
7. Refer to the spray system console manufacturer's operation manual for detailed information on monitor and flow meter storage procedures.

8. If the boom attachment will be stored separately, ensure that all open ends (e.g. hydraulic, electrical, solution, and foam marker, if equipped) are capped or covered with a suitable covering.

**Winterization Procedure**

To winterize the boom, it is recommended that you use an environmentally safe type of antifreeze and water mixture that will give you adequate protection to -30 degrees.

Drain any remaining solution in the system and rinse thoroughly. Run antifreeze mixture through the system until it comes out all attachment openings.

**Removal From Storage**

**NOTICE**

Protective compounds such as grease can harden under exposure to weather conditions. Be sure to remove any dried grease and reapply new, if necessary.

## **SECTION 4 – MAINTENANCE AND STORAGE**

---



1. Remove any dried grease from the cylinder rods and re-apply, if necessary.
2. Thoroughly clean the boom attachment.
3. Carefully unseal any openings that were sealed for storage.
4. Attach boom to the sprayer and manually cycle the hydraulics two or three times to adequately lubricate components.



## SECTION 5 – MISCELLANEOUS

### TRANSPORTING

#### Transporting Your Machine with an Attachment

#### **⚠ WARNING**

- Never operate the sprayer on a public roadway with solution in the tank.
- Never load or unload the sprayer with solution in the tank.
- Stopping the sprayer on trailer ramps may result in the sprayer to tip over.

#### **⚠ WARNING**

When transporting the sprayer, observe the following to avoid serious injury or death:

- Check for adequate clearance before driving under any overhead obstructions.
- Contact with power lines may result in serious injury or death.



#### **⚠ CAUTION**

Ensure there is adequate clearance when transporting the sprayer near an object with clearance less than the transporting height and width of the overall machine and boom attachment.

#### **⚠ CAUTION**

Avoid collisions. Before transporting machine on a public roadway, check and follow local regulations regarding size limits, the use of lights, flags, signs, pilot vehicles, and other requirements for transporting loads using trailer.

#### **⚠ CAUTION**

Ensure the booms are folded and in cradles before transporting the machine. Failure to comply may result in injury or equipment damage.

#### **⚠ CAUTION**

DO NOT operate the machine at speeds exceeding 20 mph (32 km/h) with solution in the tank. Operating speeds exceeding 20 mph (32 km/h) with a fully loaded tank may result in tire blow-out or wheel hub damage and will void the warranty.

#### Cradling the Booms

#### **⚠ CAUTION**

Booms must be in the FOLDED position when cradled. Failure to comply will result in property damage.

## SECTION 5 – MISCELLANEOUS



*NOTE: Always cradle the booms before traveling, transporting, or parking for an extended period of time.*

- Fold the outer boom extensions IN.

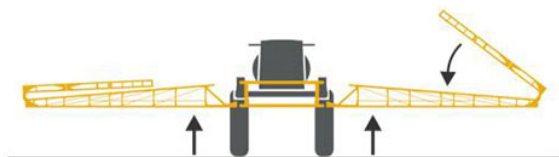

- Raise the transom all the way UP.
- Fold main boom sections IN toward the machine.

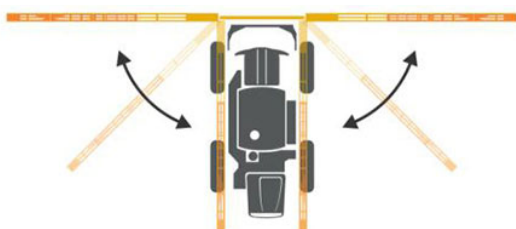

*NOTE: When boom reaches the last 8-10 degrees of travel, it will automatically slow down to avoid impact with the cradle.*

- Raise each individual boom until it clears the outer cradle stop.
- Fold the boom IN toward cradle back-stop.
- When boom touches the back-stop, lower until the full weight of the boom rests in the cradle.

### Transport Lock Pins

#### (120' Hybrid Booms)

A Transport Lock Pin assembly is installed on each side of the 120' Hybrid Boom (section 2) and must be in the "transport" (locked) position to avoid unintended boom movement when roading or trailering the machine.

### **WARNING**

Ensure the transport lock pins are in the "transport" (locked) position before roading or trailering the machine. Failure to comply may result in property damage, personal injury, or death.

### **NOTICE**

Ensure the transport lock pins are in the "stored" (unlocked) position before unfolding the booms. Failure to comply may result in property damage.

### **NOTICE**

In the event that the transport lock pin(s) become misplaced or lost, ensure the boom is secured in some other way before transporting and contact your local John Deere dealer for replacement.

### Locking the Boom for Transport

1. Remove the Transport Lock Pin (located in the mounting bracket on section 2) and move from the "stored" (unlocked) position to the "transport" (locked) position.





Transport Lock Pin  
(Shown in the “**stored**” position)  
-Typical View

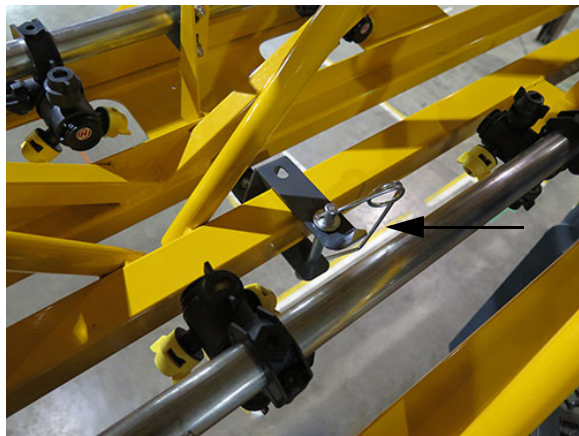

Transport Lock Pin  
(Shown in the “**transport**” position)  
-Typical View

2. Ensure the bottom side of lock pin is fastened.
3. Repeat on opposite side of boom.

### Unlocking the Boom for Use

Reverse steps by moving the Transport Lock Pins from the “transport” (locked) position to the “stored” (unlocked) position.

### Driving the Sprayer on a Public Roadway

1. Ensure the booms are in the folded/cradled position and the boom transport lock pins are in the “transport” (locked) position.

2. Transport machine at narrowest tread adjust setting only.
3. Use the flashing hazard/warning lights, day or night to warn other drivers, unless prohibited by law.
4. Know and obey all state laws for driving agricultural equipment on a public roadway.
5. Adjust machine speed to suit the conditions.
6. Slow down and use turn signals before turning.
7. Pull over to the side of the road before stopping.
8. Keep a proper lookout and maintain control of the machine.
9. Do not drive under trees, bridges, wires, or other obstructions unless there is adequate clearance.
10. Use extra care before entering or exiting a public roadway.
11. Ensure the SMV (Slow Moving Vehicle) and SIS (Speed Indicator Symbol) emblems are properly displayed to warn other drivers, unless prohibited by law.
12. Do not drive the machine at speeds exceeding 20 mph (32 km/h) with solution in the tank. Operating speeds exceeding 20 mph (32 km/h) with a fully loaded tank may result in tire blow-out or wheel hub damage and will void the warranty.

### Transporting Machine Using Trailer

#### Loading

**WARNING**

Keep all persons away from trailer when loading or unloading the sprayer. Failure to comply may result in serious injury or death.

## NOTICE

Read and understand the trailer manufacturer's operation manual. Hitch the trailer to the pulling vehicle according to their recommendations.

## NOTICE

The loaded height and width of the trailer must conform to state law in which it is being used. Do not exceed the trailer manufacturer's recommendations on loaded weight.

1. Pull the trailer to flat ground.
2. Apply the pulling vehicle's parking brake and turn the engine OFF.
3. Use tire chocks to keep the trailer from moving.
4. Fold the booms and lower into cradles.
5. Ensure the boom transport lock pins are in the "transport" (locked) position.
6. Lower the trailer ramps and set the ramp spacing for the machine's tread width setting.
7. Have an attendant help guide you onto the trailer.

*NOTE: Allow enough room between the sprayer and the pulling vehicle for turning.*

8. Deflate all four (4) air bags.
9. Secure the sprayer onto the trailer using the recommended securement restraints (see trailer manufacturer's operation manual).
10. Cover or remove the SMV (Slow Moving Vehicle) and SIS (Speed Indicator Symbol) emblems when traveling over 35 mph (55 km/h).

### Unloading

1. Pull the trailer to flat ground.
2. Apply the pulling vehicle's parking brake and turn the engine OFF.

3. Use tire chocks to keep the trailer from moving.
4. Lower the trailer ramps and set the ramp spacing for the machine's tread width setting.
5. Carefully release the securement restraints.
6. Re-inflate all four (4) air bags.
7. Have an attendant help guide you off of the trailer.
8. Uncover or replace the SMV and SIS emblems.

## QUICK-TACH SYSTEM - SPRAY BOOMS

### CAUTION

When operating or positioning the booms, observe the following safety precautions. Failure to comply may result in injury or equipment damage.

- Do not unfold boom extension when main boom is in cradle.
- Do not operate machine with one boom wing out of cradle and the other boom wing in cradle.
- Ensure booms are folded and in cradle before transporting the machine.

### WARNING

When connecting or disconnecting the booms, observe the following safety precautions:

- Monitor both sides of the boom during fold procedure.
- Select a safe area that is solid and level before unfolding/folding the booms.
- Clear area of personnel.
- Check for overhead obstructions.
- Do not unfold or fold booms near power lines. Contact with power lines can result in serious injury or death.



**⚠ WARNING**

Turn the engine OFF before connecting/disconnecting any hoses or electrical lines. Failure to comply may result in serious injury or death.

### Connecting the Boom

1. Square up to the boom.

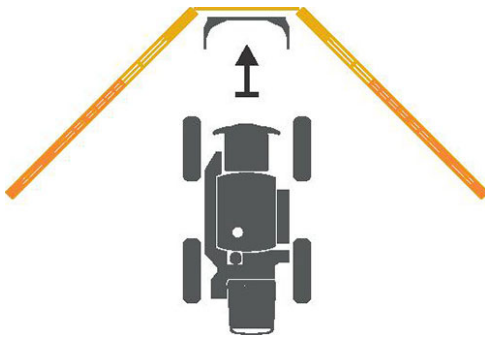

2. Disengage the Quick-Tach Lock Assemblies by pulling the Lock Pins (located on the front left and right-hand side of machine) OUT as far as it will go until it is in the “lock-out” position.

**NOTE:** “Lock-out” position prevents re-locking while attaching or detaching the attachment.

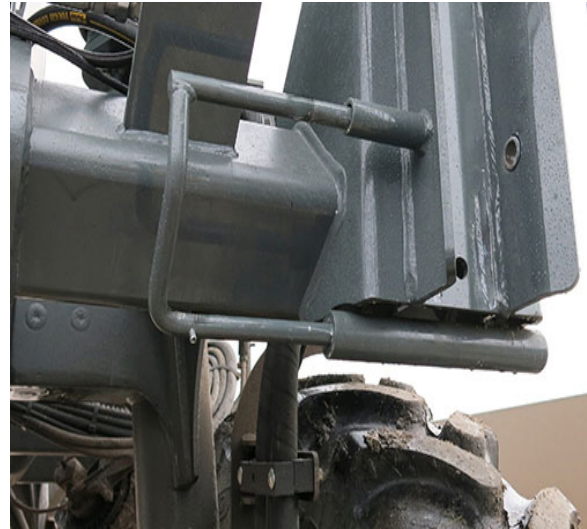

Lock Pin (2)  
(Located on the front left and right-hand side of machine)  
-Typical View  
*\* Disengaged position shown*

3. Slowly pull into the attachment.
4. Ensure the Attachment Hooks are high enough to clear the Mounting Pins.



Attachment Clearing Mounting Pin  
-Typical View

5. If necessary, lower the machine by rotating the corresponding Air Suspension Valves (located on the left-hand front air bag) in the COUNTER-CLOCKWISE (Deflate) position.



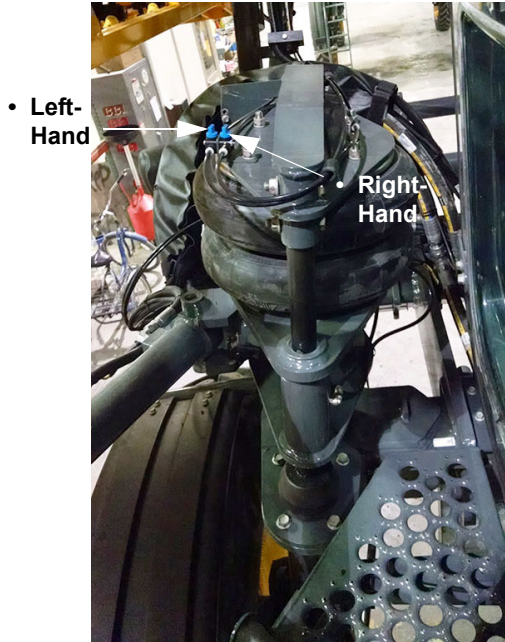

Air Suspension Valves  
(Located on the left-hand front air bag)  
-Typical View

6. Engage the parking brake.
7. **Turn the engine OFF before connecting any hoses or electrical lines!**
8. Connect all Solution, Foam Marker (if equipped), NORAC® (if equipped), Hydraulic, and Electrical Connections.

### Solution Connection



Solution Connection - **Standard**  
(Located on the front  
right-hand side of machine)  
-Typical View

### Dual Product System Solution Connections -If Equipped

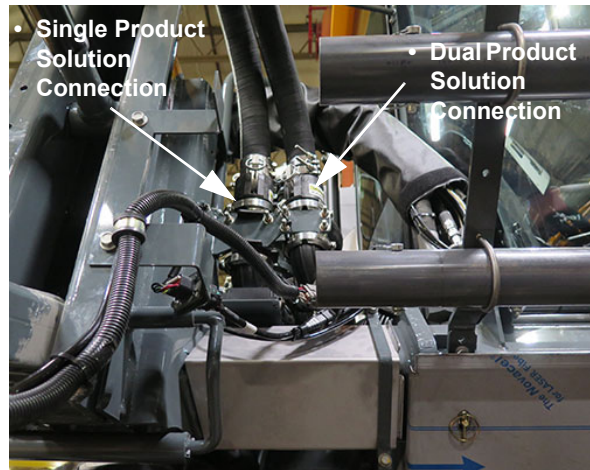

Solution Connections - **Single/Dual Product**  
(Located on the front  
right-hand side of machine)  
-Typical View



### Foam Marker Connection

-If Equipped

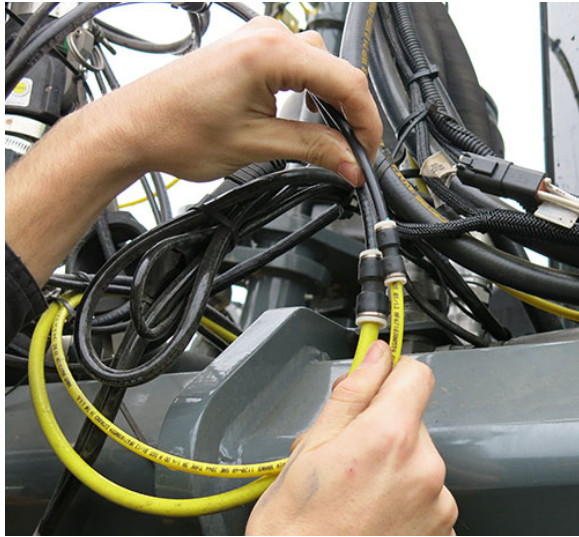

Foam Marker Connection  
(Located on the front right-hand side of machine)  
-Typical View

### NORAC Connection

-If Equipped



NORAC Connection  
(Located on the front right-hand side of machine)  
-Typical View

### Quick Connect Multi-Coupler

- Remove Hydraulic/Electric Multi-Coupler (A) from the Multi-Coupler Storage Receptacle (B) (located on the left-hand boom lift arm) and install on the front left-hand side of machine (as shown).

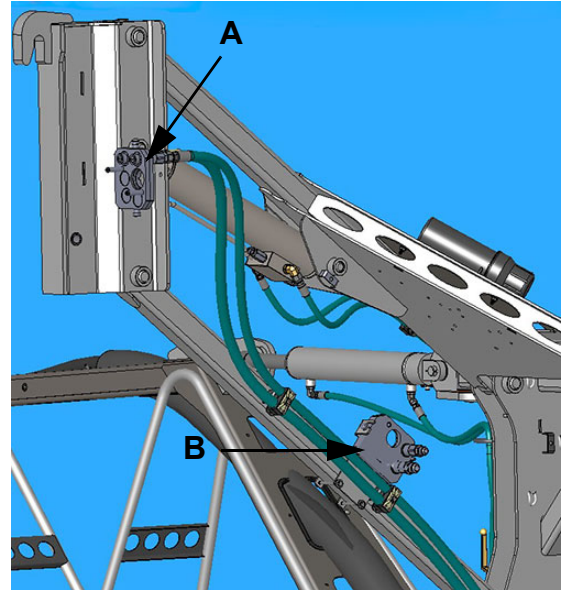

Multi-Coupler Storage Assembly  
(Located on the left-hand boom lift arm)  
-Typical View

- Install the Hydraulic/Electrical Connections (located on the left-hand side of attachment) into the Multi-Coupler Receptacle (located on front left-hand side of machine), ensuring full engagement.
- Push the Quick Connect Handle (located on the Hydraulic/Electric Multi-Coupler Assembly) OUT to engage hydraulic/electrical connections.

## SECTION 5 – MISCELLANEOUS



### Dual Product System Electrical Connection

-If Equipped

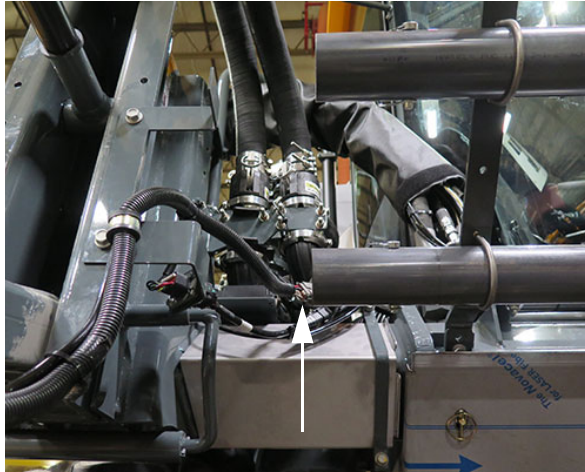

Dual Product Electrical Connection  
(Located on the front  
right-hand side of machine)  
-Typical View

9. If equipped with **NORAC**, rotate the two (2) Level Cylinder Lock Valves (one located on each left and right-hand level cylinder) in the OPEN (counter-clock-wise) position.



Level Cylinder Lock Valves (2)  
(Located near the level cylinder  
on each side of transom)  
-Typical View

10. Start the engine.
11. If the air bags were previously deflated, raise the machine by rotating the corresponding Air Suspension Valves in the **CLOCKWISE** (Inflate) position.

12. Press and hold the Transom Switch (located on the Hydrostatic Drive Control Handle) in the UP position to raise the boom until the Attachment Hooks fully engage.

*NOTE: Press and hold the Transom Switch only until the Attachment Hooks become fully engaged.*



Transom Switch - UP  
(Located on the Hydrostatic  
Drive Control Handle)  
-Typical View

*NOTE: Raising the attachment will allow the weight of the boom to pull the Attachment Hooks over the Mounting Pins. You will notice a change of weight as the machine begins to support the attachment.*

13. Engage the Quick-Tach Lock Assemblies by pushing the Lock Pins IN, ensuring full engagement.

*NOTE: If necessary, adjust the level cylinders to free the Lock Pins.*

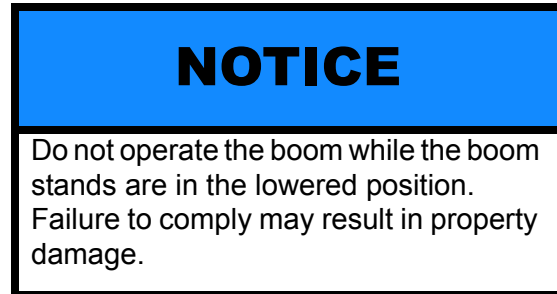
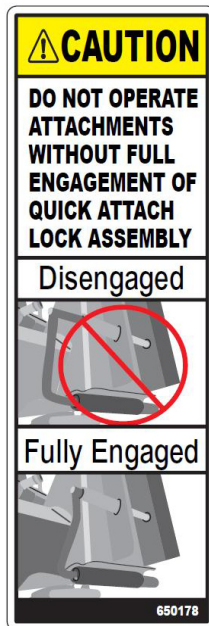

### Disconnecting the Boom

Before disconnecting the boom, determine a proper storage location. When choosing a place to store the boom, there are three important things to keep in mind:

#### Is the ground level?

The ground must be level to help prevent the attachment from falling over. Level ground will also minimize stress on the frame of the attachment when in storage.

#### Is there enough space?

The attachment needs to be partially open for it to stand properly, but be aware of the room that is needed for the attachment and adequate space to travel around it safely.

#### Is it accessible?

The attachment needs to be positioned so you can connect easily. Ensure there is enough room and that the attachment is not blocked, or blocking other items.

If temporarily storing the attachment on a soft surface (such as grass), it is recommended to place blocks or wood beneath the stands' feet to prevent the attachment from sinking into the ground.

*NOTE: It is NOT recommended to store the attachment on a soft surface for an extended period of time, due to the risk of settling soil, even when blocks or wood are used.*



Lock Pin (2)  
-Typical View  
*\* Engaged position shown*

- Place boom stands in the TRAVEL position.  
Refer to “Boom Stands” elsewhere in this section for further information.

### Unfolding the Boom for Storage

The booms must be partially open for stability when unattached from the machine. Unfold the booms approximately 10-20° (from folded position) while maintaining sufficient clearance for repositioning during reattachment. This position will allow the



## SECTION 5 – MISCELLANEOUS



booms to sit level with the transom without causing excessive stress on either part. It will also keep the weight from shifting too much in either direction (rearward or forward), which could cause the boom to tip over and/or difficulty in connecting or disconnecting the attachment.

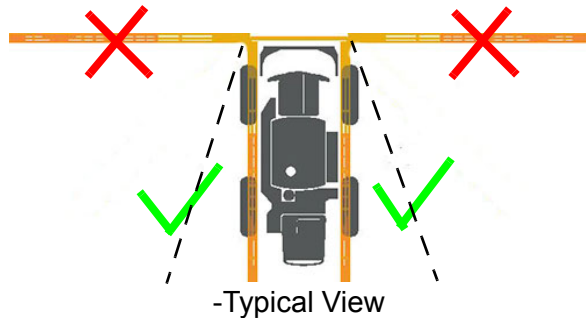

1. Press and hold the corresponding Left and Right Boom Switches (located on the Hydrostatic Drive Control Handle) in the UP position to remove boom wings from cradles.

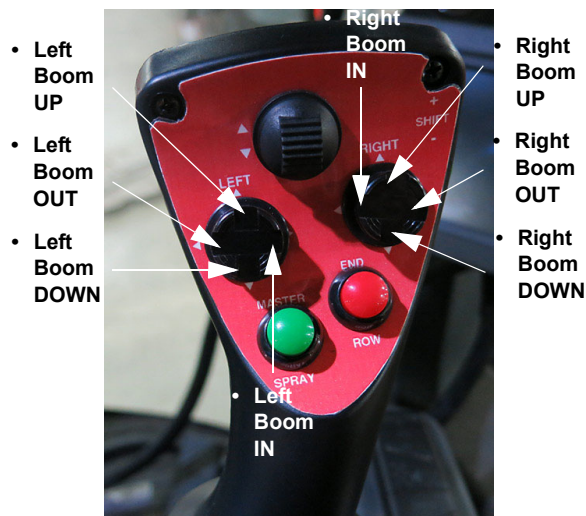

Left and Right-Hand Boom Switches  
(Located on the Hydrostatic Drive Control Handle)  
-Typical View

2. Press and hold the corresponding Left and Right Boom Switches in the OUT position to unfold the boom wings until **partially** open.

*NOTE: Booms only need to be unfolded far enough to clear the boom cradles and lower (e.g. enough to clear the front tires and allow room for steering to line up the boom). Do NOT fully extend.*

3. Lower the boom and secure the boom stands (if equipped) in the DOWN position.  
See “Boom Stands” elsewhere in this section for further information.

**⚠ WARNING**

Lower boom to the ground before disengaging the Quick-Tach Lock Assemblies.

4. Press and hold the corresponding Left and Right Boom Switches in the DOWN position to point boom tips down (until tips touch the ground).
5. Disengage the Quick-Tach Lock Assemblies by pulling the Lock Pins (located on the front left and right-hand side of machine) OUT as far as it will go until it is in the “lock-out” position.

*NOTE: “Lock-out” position prevents re-locking while attaching or detaching the attachment.*

*NOTE: If necessary, adjust the level cylinders to free the Lock Pins.*





Lock Pin (2)  
(Located on the front left and  
right-hand side of machine)  
-Typical View  
*\* Disengaged position shown*

- If necessary, lower the machine by rotating the corresponding Air Suspension Valves (located on the left-hand front air bag) in the COUNTER-CLOCKWISE (Deflate) position.

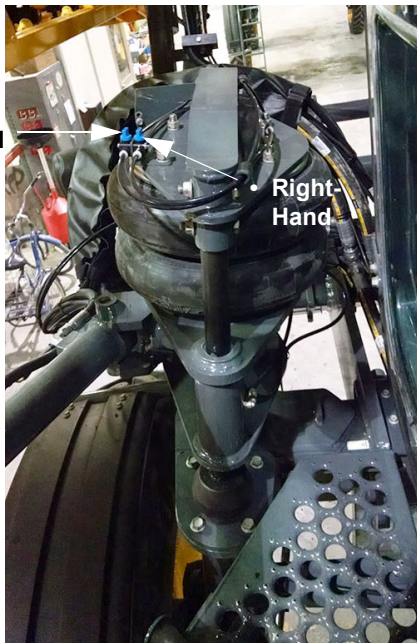

Air Suspension Valves  
(Located on the left-hand front air bag)  
-Typical View

- Ensure the Boom Solution Valve Switches (located on the side console) are in the OFF position.



Boom Solution Valve Switches  
(Located on the side console)  
-Typical View

- Disconnect the Solution, Foam Marker (if equipped), and NORAC® (if equipped) Connections, ensuring not to leave the ends in an area where they may become damaged or contaminated.

**Solution Connection**



Solution Connection - **Standard**  
(Located on the front  
right-hand side of machine)  
-Typical View

**Dual Product System Solution  
Connections**

-If Equipped

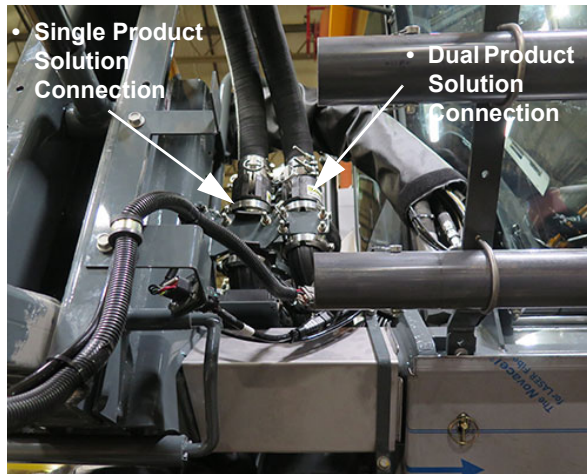

Solution Connections - **Single/Dual Product**  
(Located on the front  
right-hand side of machine)  
-Typical View

**Foam Marker Connection**

-If Equipped



Foam Marker Connection  
(Located on the front  
right-hand side of machine)  
-Typical View

**NORAC Connection**

-If Equipped



NORAC Connection  
(Located on the front  
right-hand side of machine)  
-Typical View

9. Press and hold the Transom Switch (located on the Hydrostatic Drive Control Handle) in the DOWN position and slowly lower the boom/transom assembly until Attachment Hooks clear the Mounting Pins.





Transom Switch - DOWN  
(Located on the Hydrostatic  
Drive Control Handle)  
-Typical View

*NOTE: If the air bags are inflated, a “bounce back” effect may be felt when the weight of the boom has been relieved from the machine. Once the air bags have cycled, the machine will adjust to the new weight.*



Attachment Clearing Mounting Pin  
-Typical View

10. Engage the parking brake.
11. Turn the engine **OFF** before disconnecting any hoses or electrical lines!

12. Push the Quick Connect Handle (located on the Hydraulic/Electric Multi-Coupler Assembly) IN to disengage hydraulic/ electrical connections.



Hydraulic/Electric Multi-Coupler Assembly  
(Located on the front  
left-hand side of machine)

13. Remove Hydraulic/Electric Multi-Coupler (A) from the front left-hand side of machine and reinstall on the Multi-Coupler Storage Receptacle (B) (located on the left-hand boom lift arm).

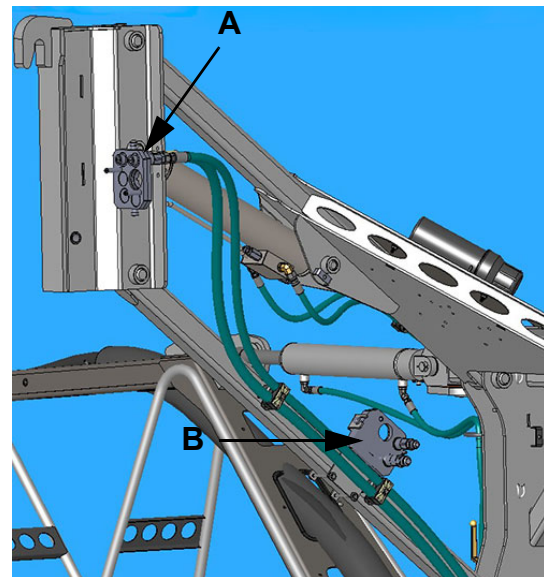

Multi-Coupler Storage Assembly  
(Located on the left-hand boom lift arm)  
-Typical View

## SECTION 5 – MISCELLANEOUS



14. If **equipped**, disconnect the Dual Product Electrical Connection (located on the front right-hand side of machine).

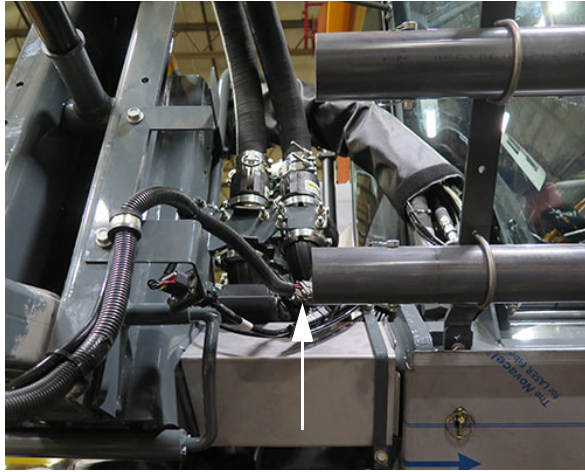

Dual Product Electrical Connection  
- if equipped  
(Located on the front  
right-hand side of machine)  
-Typical View

15. If **equipped with NORAC**, rotate the two (2) Level Cylinder Lock Valves (one located on each left and right-hand level cylinder) in the CLOSED (clockwise) position.



Level Cylinder Lock Valves (2)  
(Located near the level cylinder  
on each side of transom)  
-Typical View

16. If no other attachment is going to be installed, re-lock the Quick-Tach Lock Assemblies by pushing the Lock Pins IN.
17. Start the machine.

18. Disengage the parking brake and slowly back away from the boom.
19. If the air bags were previously deflated, raise the machine by rotating the corresponding Air Suspension Valves in the CLOCKWISE (Inflate) position.

### Boom Stands

Your boom is featured with two (2) boom stands (located on the transom).

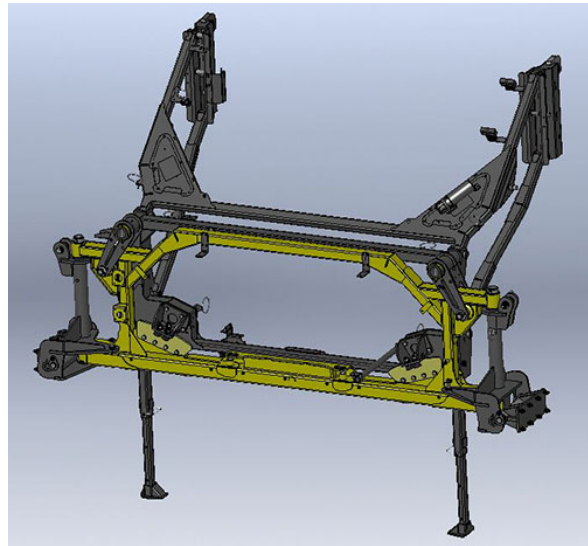

Booms Stands  
-Typical View

#### To Extend Booms Stands:

1. Remove Lock Pin (located on the outer side of transom frame) and set aside.





Lock Pin  
(Located on the outer  
side of transom frame)  
-Typical View



Mounting Bolt  
(Located on the outer  
side of transom frame)  
-Typical View



Lock Pin Removed  
-Typical View

3. With the boom stand at desired position, reinstall the Mounting Bolt, ensuring the holes of the boom stand and transom frame are properly aligned.

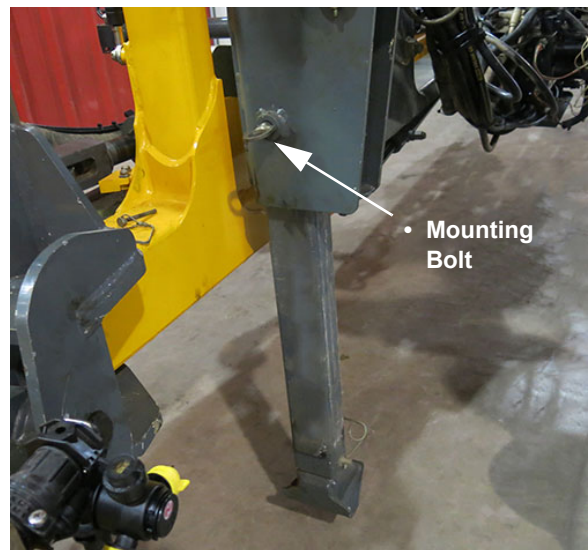

Boom Stand  
(Extended position shown)  
-Typical View

2. While supporting the bottom “foot” end of boom stand, remove the Mounting Bolt (located on the outer side of transom frame) and slowly lower boom stand to desired position.

4. Reinstall Lock Pin (that was previously removed in Step 1).
5. Repeat Steps 1-4 on opposite side of boom.

*NOTE: For additional adjustment, the “foot” end of the boom stand may also be adjusted to best suit your situation*

## **SECTION 5 – MISCELLANEOUS**

---



*(e.g. boom height, ground level, etc.)  
Adjust in the same manner as  
previously described.*

6. Reverse steps to store booms stands in "travel" position.

**TROUBLESHOOTING**

<b>Problem</b>	<b>Possible Cause</b>	<b>Suggested Remedy</b>
Boom sections will not fold in	<ul style="list-style-type: none"> <li>• Operating the manual boom switches when boom state is in Auto Mode</li> <li>• Position sensor error (Auto Mode is inoperable)</li> </ul>	<ul style="list-style-type: none"> <li>• Use the proper switches for the selected boom state</li> <li>• Use manual boom switches</li> <li>• Contact your local John Deere dealer for assistance</li> </ul>
Boom will not recharge	<ul style="list-style-type: none"> <li>• Proximity/Position Sensor error</li> <li>• Software bug</li> </ul>	<ul style="list-style-type: none"> <li>• Check for error message on Machine Display</li> <li>• Unfold each section in Manual Mode</li> <li>• Contact your local John Deere dealer for assistance</li> </ul>
Boom will not operate when manual boom switches are pressed	<ul style="list-style-type: none"> <li>• Acknowledge power line warning on Machine Display</li> </ul>	<ul style="list-style-type: none"> <li>• Contact your local John Deere dealer for assistance</li> </ul>
Boom up/down functions inoperable	<ul style="list-style-type: none"> <li>• NORAC system not functioning properly/ communication error</li> </ul>	<ul style="list-style-type: none"> <li>• Check NORAC system status</li> <li>• Restart machine</li> <li>• Contact your local John Deere dealer for assistance</li> </ul>



---

A Word From Hagie Manufacturing	
Company .....	1-1
About This Manual .....	1-1
Fence Row Applicator .....	3-22
Identification .....	1-2
Intended Use .....	2-1
Operator's Station .....	3-1
Product Warranty .....	1-2
Quick-Tach System - Spray Booms .....	5-4
Safety Decals .....	2-4
Safety Messages Used In This	
Manual .....	1-2
Safety Precautions .....	2-1
Service - Lubrication .....	4-1
Service - Miscellaneous .....	4-2
Service and Assistance .....	1-2
Service Intervals .....	4-4
Specifications .....	1-4
Spray Booms .....	3-6
Storage .....	4-4
Transporting .....	5-1
Troubleshooting .....	5-17



# NOTES

---

# NOTES

---

# NOTES

---