

**2021 BOOM  
OPERATOR'S MANUAL  
493882**





**HAGIE**  
**CONTENTS**

---

**1 – INTRODUCTION**

A Word From Hagie Manufacturing Company ..... 1-1  
About This Manual ..... 1-1  
Safety Messages Used In This Manual ..... 1-2  
Service and Assistance ..... 1-2  
Product Warranty ..... 1-3  
Identification ..... 1-3  
Specifications ..... 1-4

**2 – SAFETY AND PRECAUTIONS**

Intended Use ..... 2-1  
Safety Precautions ..... 2-1  
Safety Decals ..... 2-4

**3 – OPERATING YOUR SPRAY BOOM**

Operator's Station ..... 3-1  
Spray Booms - 90/100/120/132' Hybrid ..... 3-6  
Fence Row Applicator ..... 3-25

**4 – MAINTENANCE AND STORAGE**

Service - Lubrication ..... 4-1  
Service - Miscellaneous ..... 4-2  
Service Intervals ..... 4-4  
Storage ..... 4-4

**5 – MISCELLANEOUS**

Transporting ..... 5-1  
Quick-Tach System - Spray Booms ..... 5-4  
Troubleshooting ..... 5-16



## SECTION 1 – INTRODUCTION

---

### A WORD FROM HAGIE MANUFACTURING COMPANY

Congratulations on the purchase of your spray boom attachment! Read this operator's manual and become familiar with operating procedures and safety precautions before attempting to operate your spray boom.

As with any piece of equipment, certain operating procedures, service, and maintenance are required to keep your spray boom in top running condition. We have attempted herein to cover all of the adjustments required to fit varying conditions. However, there may be times when special care must be considered.

*NOTE: The operator is responsible for inspecting the spray boom and having parts repaired or replaced when continued use of the product causes damage or excessive wear to other parts.*

Hagie Manufacturing Company reserves the right to make changes in the design and material of any subsequent spray boom without obligation to existing attachments.

Thank you for choosing a Hagie spray boom and we ensure you of our continued interest and support in its optimal performance for you. We are proud to have you as a customer!

### ABOUT THIS MANUAL

#### NOTICE

The purpose of this manual is to guide you in the proper operation of the spray boom attachment, as well as provide you with pertinent safety precautions and maintenance information. Refer to your sprayer operator's manual and all other literature that is included with the machine for complete instructions on machine operation.

#### NOTICE

Any pictures or illustrations contained within this manual that depict situations with shields, guards, rails, or lids removed are for demonstration only. Keep all shields and safety devices in place at all times.

This manual will aid you in the proper operation and service of your spray boom attachment. It is the responsibility of the user to read the operator's manual and comply with the correct and safe operating procedures, as well as maintain the product according to the service information provided in the *Maintenance and Storage Section* elsewhere in this manual.

Photographs and illustrations used in this manual are of general nature only. Some of the equipment described and/or shown may or may not be available on your spray boom.

Information described in this manual was correct at the time of printing. Because of Hagie Manufacturing Company's continuous product improvement, certain information

may not be included in this manual. To obtain the most current operator's manual for your attachment, please visit [www.hagie.com](http://www.hagie.com).

Keep this manual in a convenient place for easy reference. This manual is considered a permanent fixture of the product. In the event of resale, this manual must accompany the spray boom.

If you do not understand any part of this manual or require additional information or service, contact your local John Deere dealer for assistance.

## **SAFETY MESSAGES USED IN THIS MANUAL**

The following safety messages found throughout this manual alert you of situations that could become potentially dangerous to the operator, service personnel, or equipment.

### **⚠ DANGER**

The signal word DANGER indicates a hazardous situation which, if not avoided, will result in death or serious injury.

### **⚠ WARNING**

The signal word WARNING indicates a hazardous situation which, if not avoided, could result in death or serious injury.

### **⚠ CAUTION**

The signal word CAUTION indicates a hazardous situation which, if not avoided, could result in minor or moderate injury. CAUTION may also be used to alert against unsafe practices associated with events which could lead to personal injury.

### **NOTICE**

The signal word NOTICE indicates operator awareness which, if not avoided, may result in personal or property damage.

*NOTE: A "Note" is intended to make special mention of, or remark on.*

## **SERVICE AND ASSISTANCE**



### **John Deere Is At Your Service**

Customer satisfaction is important to Hagie and John Deere. Our dealers strive to provide you with prompt, efficient parts and service:

- Maintenance and service parts to support your equipment.

## SECTION 1 – INTRODUCTION



- Trained service technicians and the necessary diagnostic and repair tools to service your equipment.

### Customer Satisfaction Problem Resolution Process

Your John Deere dealer is dedicated to supporting your equipment and resolving any problem you may experience.

1. When contacting your dealer, be prepared with the following information:
  - Machine model and product identification number.
  - Date of purchase.
  - Nature of problem.
2. Discuss problem with dealer service manager.
3. If unable to resolve, explain problem to dealership manager and request assistance.
4. If you have a persistent problem your dealership is unable to resolve, ask your dealer to contact John Deere for assistance, or contact the Ag Customer Assistance Center at 1-866-99DEERE (866-993-3373) or e-mail us at [www.deere.com/en\\_US/ag/contactus](http://www.deere.com/en_US/ag/contactus).

The spray booms have an identification plate mounted on the lower right-hand side of transom that provides boom model and serial number.



Hybrid Boom Identification Plate  
-Typical View

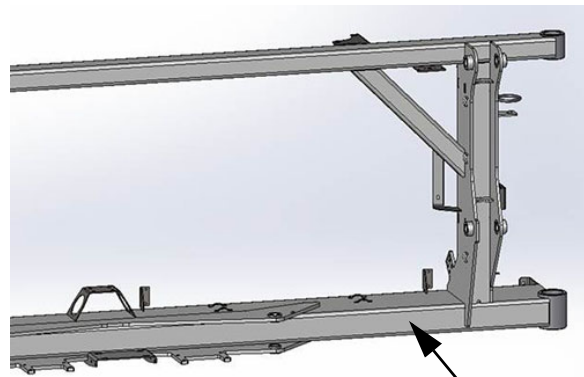

Hybrid Boom Identification Plate Location  
-Typical View

Serial No. \_\_\_\_\_

## PRODUCT WARRANTY

Please contact your local John Deere dealer for further information.

## IDENTIFICATION

### NOTICE

Reference to right and left-hand used throughout this manual refers to the position when seated in the operator's seat facing forward.

## **SPECIFICATIONS**

*NOTE: Dimensions may vary, depending on tire size.*

*NOTE: Refer to “Specifications” provided in the machine operator’s manual for complete machine and boom dimensions.*

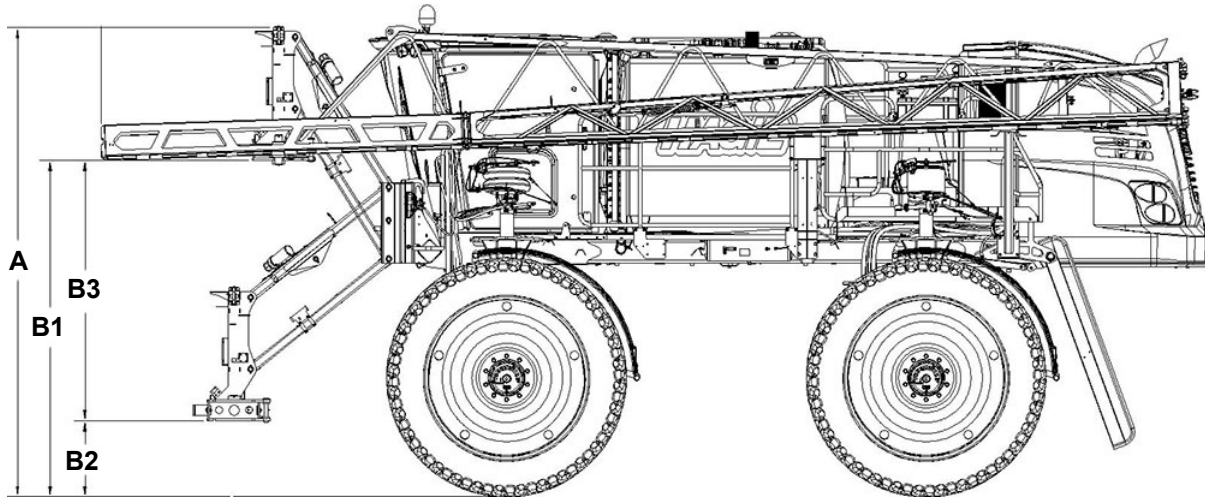

*Your machine may vary, depending on boom option*

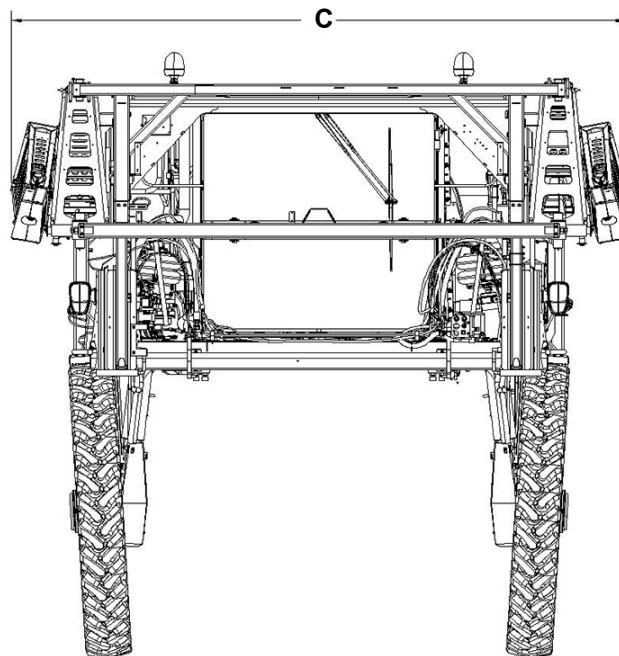

*Your machine may vary, depending on boom option*

	Description	Specification
A	Raised Transom Height	<ul style="list-style-type: none"> <li>• 153”/388.6 cm (from top of transom) *</li> <li>• 155.5”/395 cm (from top of solution hose) *</li> </ul>
B3	Transom Lift Range (B1 minus B2)	87” (110” - 23”) 221 cm (279.4-58.4 cm)
C	Overall Width (booms folded, 120”/304.8 cm tread)	168” (426.7 cm)

\* Refer to “Tire Specifications” provided in the machine operator’s manual for a complete listing of tire options when configuring machine specifications on your model.

**NOTICE**

Because Hagie Manufacturing Company offers a variety of options, the illustrations in this manual may show a machine equipped other than standard. Machine dimension and weight values may vary, depending on available equipment.

**Boom Weight (Approximate)**

- 4,280 lbs./1,941 kg (90’ Hybrid Boom)
- 4,360 lbs./1,977 kg (100’ Hybrid Boom)
- 4,180 lbs./1,896 kg (120’ Hybrid Boom)
- 4,600 lbs./2,086 kg (132’ Hybrid Boom)

Item	Specification
<b>General</b>	
Spray Booms	<ul style="list-style-type: none"> <li>• 90’ Hybrid - 7 sections</li> <li>• 100’/120’/132’ Hybrid - 9 sections</li> </ul>
Type	1” (2.5 cm) schedule 5 stainless wet boom plumbing
Controls	Electro-hydraulic (fold/lift/level)
Level Shock Absorber	Gas charged accumulator
90’/100’/120’/132’ Inner Boom Breakaway	Hydraulic, manual reset
90’/100’/120’/132’ Outer Boom Breakaway	Mechanical with spring, auto reset
Pressure Gauge	160 PSI (11 bar), Glycerin Filled





## SECTION 1 – INTRODUCTION

Fence Row Nozzle	Remote activated (left and right)
Boom Solution Valves	Ball valves, electric actuation, stainless ball and stem, PTFE seats
<b>Electrical (Lights)</b>	
Transom	2 trapezoidal headlights
Quick-Tach Mount	2 trapezoidal headlights (high/low beam), 2 oval amber lights (combined)
Boom Cradle	2 trapezoidal floodlights (1 on each cradle), 2 oval amber lights (1 on each cradle)
Spray Boom Indicators (located on boom, if equipped)	1 oval white light, 2 oval amber lights, 9 oval red lights
Night Spray - if equipped	2 spot beam lights (1 on each main boom fold section)



## SECTION 2 – SAFETY AND PRECAUTIONS

---

### INTENDED USE

#### NOTICE

This attachment is designed for and intended to be used for the application of chemicals and fertilizers to field crops. Use in any other way or for any other purpose is considered misuse of this attachment.

Most accidents occur as the result of failure to follow basic and fundamental safety rules and precautions. Recognizing potential safety hazards, following correct and safe operating procedures described in this manual, and complying with safety warnings located throughout the machine and attachment may reduce the risk of accidents.

There is no way to completely eliminate the potential for danger when operating agricultural equipment. Therefore, you must study this operator's manual and understand how to operate the attachment controls for safe operation before using the attachment. Likewise, never let anyone operate the attachment without proper instruction.

Do not operate the attachment for anything other than its intended use. Hagie Manufacturing Company shall not be liable for any damage, injury, or death associated with improper use of the attachment.

Do not make any modifications such as, but not limited to, weldments, add-ons, adaptations, or changes from the original design of the attachment. Such modifications may become safety hazards to you and others and **will void all warranties**.

Replace missing, faded, or damaged safety signs. Refer to "Safety Decals" elsewhere in this section for correct sign and placement.

### SAFETY PRECAUTIONS

#### General Safety

- Before operating the attachment, ensure there are no obstacles or persons in the path of travel.
- The hydraulic and electrical control systems are optimized for use with this attachment. Any modification to these systems may lead to unintended or uncontrolled motion. Do NOT install add-on control systems that are not approved by Hagie Manufacturing Company.
- Some conditions cannot be completely safeguarded against without interfering with efficient operation of the machine and/or reasonable accessibility. In these cases, decals have been installed to provide the operator with hazard information. Do NOT remove decals for any reason. If a decal is damaged or missing, contact your local John Deere dealer for replacement.



#### Wear Protective Clothing

- Do not wear loose fitting clothing that could get caught in moving parts. Wear safety equipment that is appropriate for the job.



- Do not store chemical-soaked clothing in the cab. Clean off as much mud and dirt from your shoes as you can before entering the cab.

### Protect Against Noise

- Wear suitable hearing protection. Prolonged exposure to loud noise may result in loss of hearing.



### Be Prepared

- Be prepared for an emergency. Keep a fire extinguisher, first aid kit, and clean water in the cab at all times.
- Service the fire extinguisher regularly.
- Keep an accurate inventory of supplies in the first aid kit and dispose of any items that have expired.

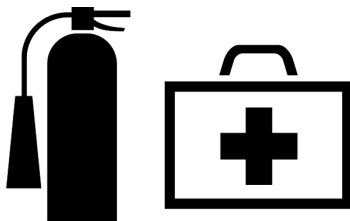

### General Repair/Maintenance Safety

- Turn off sprayer engine before checking, adjusting, repairing, lubricating, or cleaning any part of the attachment.
- Remove all chemical residue from the work area before performing service/maintenance.
- Disconnect the battery ground cable and turn the Battery Disconnect Switch OFF before servicing the electrical system or welding on an attachment.



### Remove Paint Before Welding or Heating

- Avoid toxic fumes and dust. Hazardous fumes can be generated when paint is heated by welding, soldering, or using a torch.



- Do not use chlorinated solvents in areas where welding will take place.
- Perform all work in an area that is well ventilated to carry toxic fumes and dust away.
- Dispose of paint and solvents properly.

### Avoid Heating Near Pressurized Lines

- Avoid torching, welding, and soldering near pressurized hydraulic lines. Pressurized lines may accidentally burst

when heat goes beyond the immediate flame area.



### Safe Hydraulic Maintenance

- Always practice personal safety when performing service or maintenance on the hydraulic system.
- Use caution when working around hydraulic fluid under pressure. Escaping fluid can have sufficient force to penetrate your skin, causing serious injury. This fluid may also be hot enough to burn.

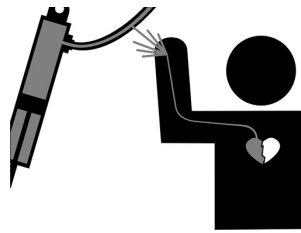

- Always lower the load or relieve pressure before repairing a hydraulic leak.

### General Spray Boom Safety

- Select a safe area before unfolding/folding the booms.
- Clear area of personnel.
- Booms must be folded and in cradles when driving the machine on a roadway or when near power lines.
- Cradle booms when leaving sprayer unattended.
- Ensure booms are folded when cradled.
- Do not unfold boom extension when main boom is in the cradle.
- Never operate the sprayer with one boom wing out of the cradle, and the other boom wing in the cradle.
- Check for overhead obstructions.
- Do not unfold or fold booms near power lines. **Contact with power lines can result in serious injury or death.**

A warning message will appear on the Machine Display before extending the outer boom extensions or when operating in Auto Fold. Press ACKNOWLEDGE showing that you have acknowledged that there are no overhead power lines or obstructions before proceeding.



### Cold Oil Scenarios

- If the oil temperature is less than 32°F, the operator may experience control loss on the main and outer fold cylinders. These cylinders are the main cylinders affected by over-running loads due to the weight rotation of the boom during unfold/fold situations. When the oil is cold, the valve response is not as fast or accurate. Therefore, when having to lift the weight, the cylinder will move slower, but in trying to suspend the weight, the weight may cause faster movement, as the valve is not dampening the flow like it normally would.

*NOTE: This situation requires the operator to clear area of personnel.*

### Handle Agricultural Chemicals Safely

Agricultural chemicals used in applications can be harmful to your health and the environment if not used properly.

- Always follow the manufacturer's label for directions of use.
- Never allow chemicals to come in contact with your skin or eyes. Always use the proper Personal Protective Equipment (PPE).
- Never pour chemicals into an empty solution tank. Always fill tank half full of water first.

- Dispose of empty chemical containers properly.



- Wash spilled chemicals or spray residue from the sprayer to prevent corrosion and deterioration.
- Select safe areas to fill, flush, calibrate, and clean sprayer where chemicals will not run off to contaminate people, animals, vegetation, or water supply.
- Never place a spray nozzle to your lips in an attempt to unclog it.
- Do not spray when wind is in excess of chemical manufacturer’s recommendation.
- Store chemicals in their original containers with the label intact.
- Store chemicals in a separate, locked building.
- Wear Personal Protective Equipment (PPE) as recommended by the chemical manufacturer.

## SAFETY DECALS

Decals warning you of avoidable danger are located on various parts of the attachment. They are there for your personal safety and protection. DO NOT remove them. They will fracture upon attempted removal and therefore, must be replaced.

Following are locations of important safety decals. Replace them if they are damaged or missing. All safety decals, instructional decals, or machine striping may be purchased through your local John Deere dealer.

To replace safety decals, ensure the installation area is clean and dry and decide on exact position before you remove the backing paper.

### Decal Locations

**N204628**

(Located on front left-hand cab post)



**650178**

(Located near each quick-tach lock pin assembly)

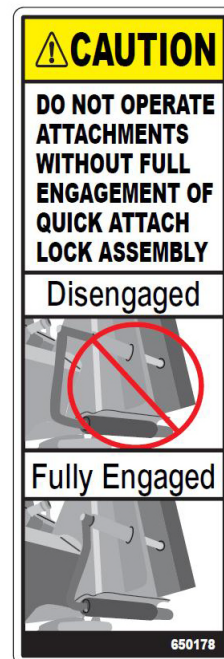

## SECTION 2 – SAFETY AND PRECAUTIONS



### HXE28534

(1) - Located on front left-hand cross member near quick connect multi-coupler

(1) - Located on inside of transom

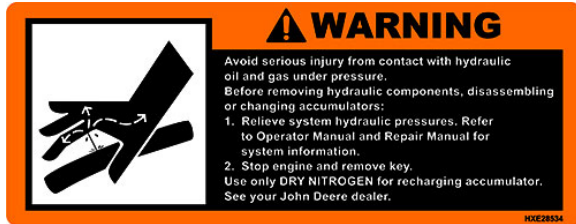

### 650210

(Located on each NORAC® sensor)





## SECTION 3 – OPERATING YOUR SPRAY BOOM

### OPERATOR'S STATION

*NOTE: Refer to your machine operator's manual for a full description of cab functions and spray system operation.*

#### Side Console

- (A) - Boom Solution Valve Switches
- (B) - Fence Row Switch (Left)
- (C) - Fence Row Switch (Right)
- (D) - Boom Extension Switches (Left/Right Outer Fold)
- (E) - Transom Switch (Up/Down)
- (F) - Left-Hand Boom Switch
- (G) - Right-Hand Boom Switch
- (H) - Master Spray Switch



-Typical View



-Typical View

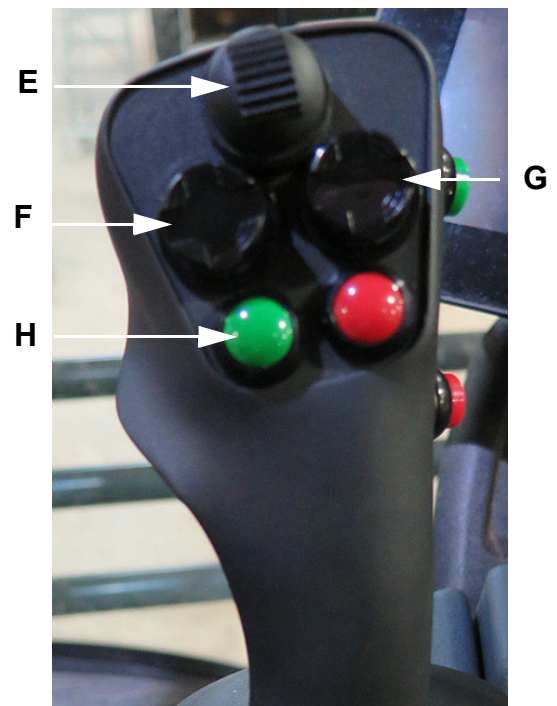

-Typical View

#### Boom Solution Valve Switches

The Boom Solution Valve Switches (located on the side console) each control a valve located on the boom or transom. The valves control the flow of the solution through the boom.

## SECTION 3 – OPERATING YOUR SPRAY BOOM



The boom is divided into sections, with the far left tip being the beginning of the first section. Each Boom Solution Valve Switch is equipped with an indicator light and will illuminate red when manually turned off.

- Press the Boom Solution Valve Switches to turn ON. Press again to turn OFF.



Boom Solution Valve Switches  
(Located on the side console)  
-Typical View

### Fence Row Switches

The Fence Row Switches (located on the side console) are used in the selection of either the right or left fence row spray nozzle.

- Press the desired Fence Row Switch (Left or Right) to turn ON. Press switch again to turn OFF.

*NOTE: The corresponding Fence Row Switch will illuminate when active.*

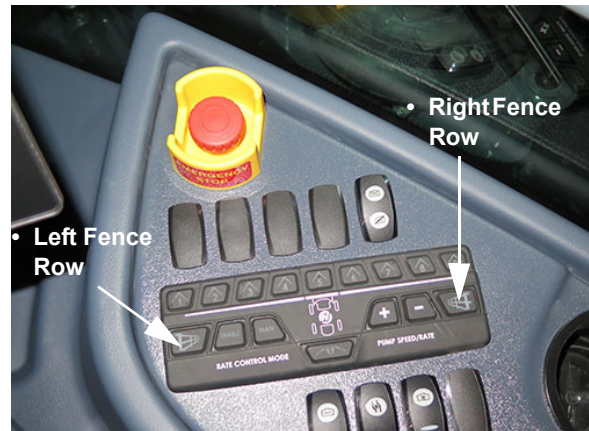

Fence Row Switches - Left/Right  
(Located on the side console)  
-Typical View

### Boom Extension Switches (Outer Fold)

#### **⚠ WARNING**

When operating or positioning the booms, observe the following safety precautions to avoid serious injury or death:

- Select a safe area before folding/unfolding booms.
- Clear area of personnel.
- Check for overhead obstructions.
- Do not fold/unfold booms near power lines. Contact with power lines can result in serious injury or death.





### ⚠ CAUTION

When operating or positioning the booms, observe the following safety precautions to avoid injury or equipment damage.

- Do not fold/unfold boom extensions when main boom is in cradle.
- Do not operate sprayer with one boom wing out of cradle and the other boom wing in cradle.
- Do not transport machine without booms folded and in cradle.

The Boom Extension Switches (located on the side console) are used to extend or retract the outer boom extensions.

- Press and hold desired Boom Extension Switch (left or right) in the UP position to unfold corresponding boom extension OUT.
- Press and hold desired Boom Extension Switch (left or right) in the DOWN position to fold corresponding boom extension IN.

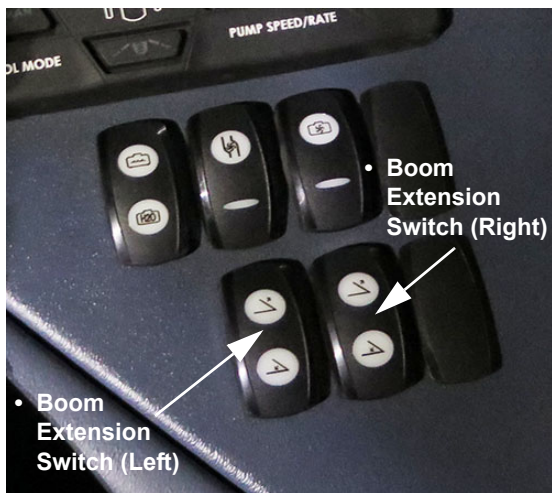

Boom Extension Switches - Left/Right  
(Located on the side console)  
-Typical View

### Left and Right-Hand Boom Switches

The Left and Right-Hand Boom Switches (located on the Hydrostatic Drive Control Handle) are used to raise, lower, extend, and retract the spray booms.

### Transom Switch - Up/Down

The Transom Switch (located on the Hydrostatic Drive Control Handle) is used to raise and lower the main lift.

### Master Spray Switch

The Master Spray Switch (located on the Hydrostatic Drive Control Handle) activates the boom solution valves.

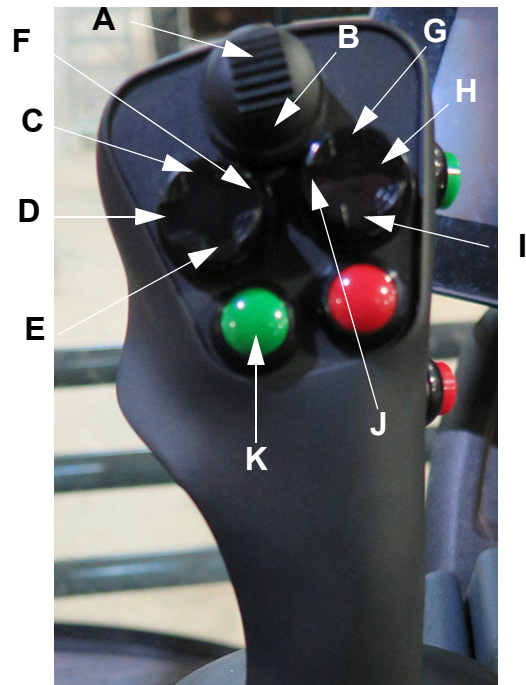

- (A) - Transom UP
- (B) - Transom DOWN
- (C) - Left Boom UP
- (D) - Left Boom OUT
- (E) - Left Boom DOWN
- (F) - Left Boom IN
- (G) - Right Boom UP
- (H) - Right Boom OUT
- (I) - Right Boom DOWN
- (J) - Right Boom IN
- (K) - Master Spray

## Monitors and Controls

### Precision Display

The solution system is controlled by the Precision Display, which receives data and automatically makes adjustments based on the target rate of application set by the operator. NORAC® boom height functions are also controlled through the display.



Precision Display  
-Typical View

### Machine Display

The Machine Display is the central control center of the machine. It controls many of the machine's electronically-driven functions, including attachment operation.



Machine Display  
-Typical View

The Machine Display also activates the Work Lights, Attachment Lights, and Night Spray Lights (if equipped).

### Work Lights

The Work Lights (located on each boom cradle) are for use when operating in the field after dark and are turned on/off through the Machine Display.



Work Lights (2)  
(Located on each boom cradle)  
-Typical View

- Press the Lights Button (located on the Machine Display Main Menu Page) to navigate to the “Exterior Lighting” screen.



Lights Button  
(Located on the Machine Display  
Main Menu Page)

- Press the Work Lights Button (WRK) to turn Work Lights ON. Press button again to turn Work Lights OFF.

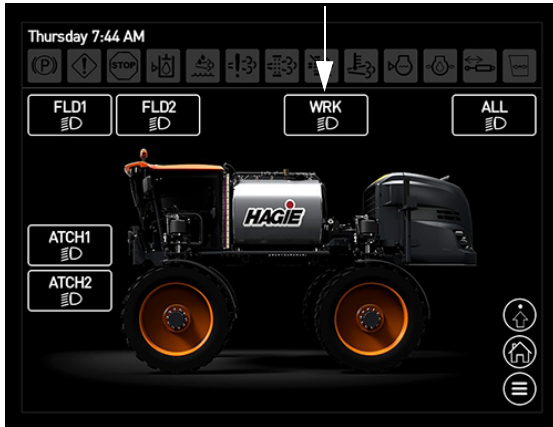

**Work Lights Button (WRK)**  
(Located on the Machine Display  
Exterior Lighting Screen)

*NOTE: Turn Work Lights OFF before entering a public roadway.*

*NOTE: The ignition key must be in the ON position to operate the Work Lights.*

### Attachment Lights

The Attachment Lights (located on the front of transom) are for use when operating in the field after dark and are turned on/off through the Machine Display.

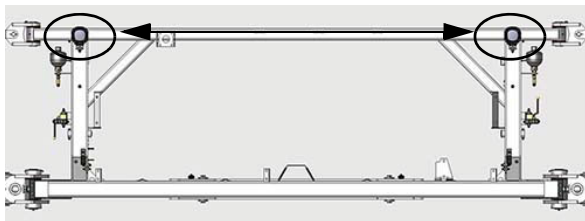

**Attachment Lights (2)**  
(Located on the front of transom)  
-Typical View

- Press the Lights Button (located on the Machine Display Main Menu Page) to navigate to the “Exterior Lighting” screen.



**Lights Button**  
(Located on the Machine Display  
Main Menu Page)

- Press the Attachment Lights Button (ATCH1) to turn Attachment Lights ON. Press button again to turn Attachment Lights OFF.

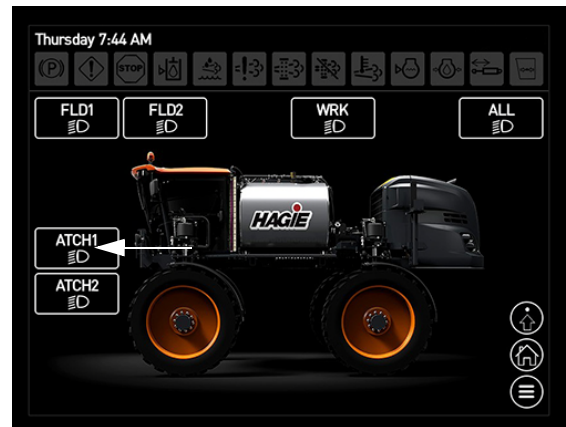

**Attachment Lights Button (ATCH1)**  
(Located on the Machine Display  
Exterior Lighting Screen)

*NOTE: Turn Attachment Lights OFF before entering a public roadway.*

*NOTE: The ignition key must be in the ON position to operate the Attachment Lights.*

### Night Spray Lights

#### -If Equipped

The Night Spray Lights (located on each side of the main boom fold section) are for use when operating in the field after dark and are turned on/off through the Machine

## SECTION 3 – OPERATING YOUR SPRAY BOOM



Display. The Night Spray Lights are adjustable and may be positioned to light up the spray pattern.

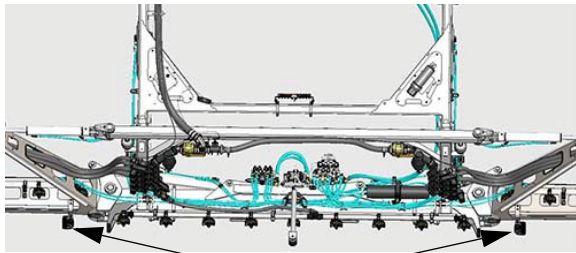

Night Spray Lights (2)  
(Located on each side of  
the main boom fold section)  
-Typical View

- Press the Lights Button (located on the Machine Display Main Menu Page) to navigate to the “Exterior Lighting” screen.



Lights Button  
(Located on the Machine Display  
Main Menu Page)

- Press the Night Spray Lights Button (ATCH2) to turn Night Spray Lights ON. Press button again to turn Night Spray Lights OFF.

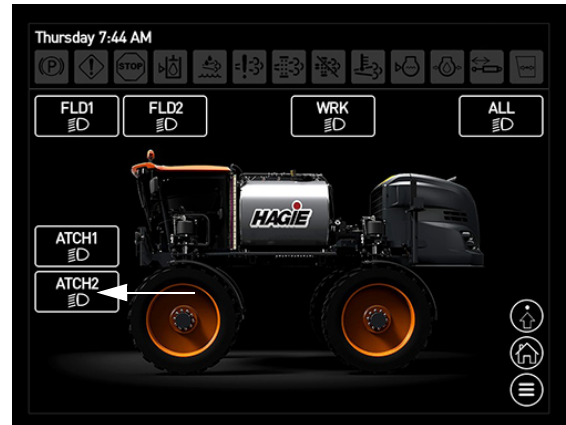

Night Spray Lights Button (ATCH2)  
(Located on the Machine Display  
Exterior Lighting Screen)

*NOTE: The Battery Disconnect Switch (located on the rear mainframe) must be in the ON position to activate the Night Spray Lights.*

*NOTE: Turn the Night Spray Lights OFF before entering a public roadway.*

## SPRAY BOOMS - 90/100/ 120/132' HYBRID

The spray booms are controlled by an electro-hydraulic system. This system consists of operator-manipulated switches (located on the side console and the hydrostatic drive control handle) and hydraulic cylinders (attached to the booms), which provide lift, level, and horizontal extension.

⚠ DANGER



To avoid injury or death do not contact electric lines when moving or operating this machine.

N204628

⚠ WARNING



Avoid serious injury from contact with hydraulic oil and gas under pressure. Before removing hydraulic components, disassembling or changing accumulators:

1. Relieve system hydraulic pressures. Refer to Operator Manual and Repair Manual for system information.
2. Stop engine and remove key. Use only DRY NITROGEN for recharging accumulator. See your John Deere dealer.

HXE23534







⚠ CAUTION

**Unexpected movement can cause serious injury or death**

Objects directly below sensors will cause the boom wing to move. Disengage NORAC system before approaching sensors.

650210

⚠ WARNING

When operating or positioning the booms, observe the following safety precautions:

- Monitor both sides of the boom during fold procedure.
- Cradle booms when leaving the machine unattended.
- Ensure booms are folded when cradled.
- Select a safe area before unfolding/folding the booms.
- Clear area of personnel.
- Check for overhead obstructions.
- Do not unfold/fold booms near power lines. Contact with power lines can result in serious injury or death.
- Spray equipment is designed for FIELD USE ONLY. Do not attempt to use machinery for anything other than it's intended purpose.

⚠ WARNING

Hydraulic and electrical control systems are optimized for use of the spray boom attachment. Any modification to these systems may lead to unintended and uncontrolled motion. **DO NOT** install add-on control systems that are not approved by Hagie Manufacturing Company.

**⚠ CAUTION**

When operating or positioning the booms, observe the following safety precautions. Failure to comply may result in injury or equipment damage.

- Do not unfold/fold boom extensions when main boom is in cradle.
- Do not operate machine with one boom wing out of cradle and the other boom wing in cradle.
- Ensure booms are folded and in cradle before transporting the machine.

### Power Lines

Hagie Manufacturing Company cannot stress enough that extreme caution must be taken when operating equipment near power lines. Ensure there is more than sufficient clearance when transporting, unfolding and folding the boom, or spraying near power lines.



As a safety precaution, a Power Line Warning Message will appear on the Machine Display before extending the outer boom extensions or when operating in Auto Fold. Press ACKNOWLEDGE showing that you have acknowledged that there are no overhead power lines or obstructions before proceeding.

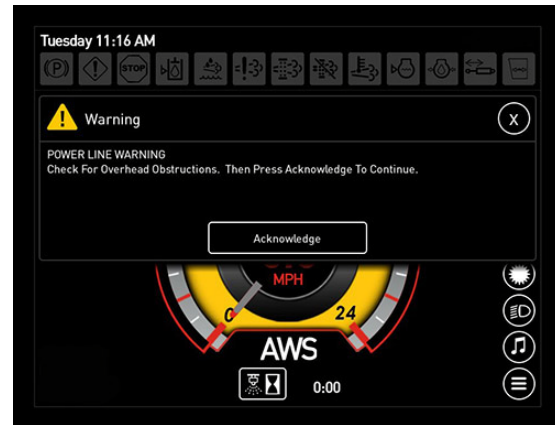

Power Line Warning Message  
(Located on the Machine Display)

Hydraulically folding the spray boom extensions (outer folds) and shutting off the outer section valves (Boom Solution Valve Switches 1, 2, 8, and 9) essentially turns it into a 60-ft. boom (90/100/120' hybrid) or 70-ft. boom (132' hybrid) (see the following illustrations).

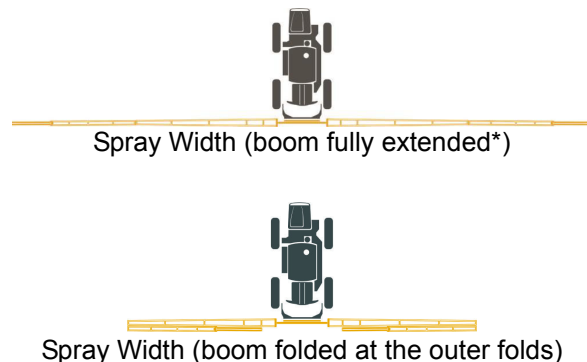

\* **Recommended spray width**

### Spray Boom Components

- Fixed Transom
- Level Cylinders
- NORAC® Sensors
- Position Sensors
- Accumulators
- Main Fold/Breakaway Cylinders
- Outer Breakaway (Tip)

### Fixed Transom

The Fixed Transom and lift arm house the lift cylinders, pressure gauge, roll lock cylinders, boom stands, fold control manifold,

Hagie-installed modules, NORAC center sensor, and the NORAC lift/level hydraulic manifold.

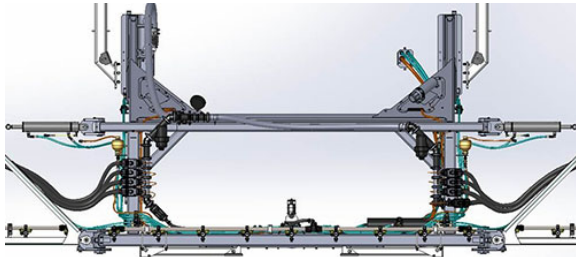

Fixed Transom  
-Typical View

### Level Cylinders

The Level Cylinders (located on each side of the transom) are responsible for the up and down movement of the boom wings when the level controls are activated.

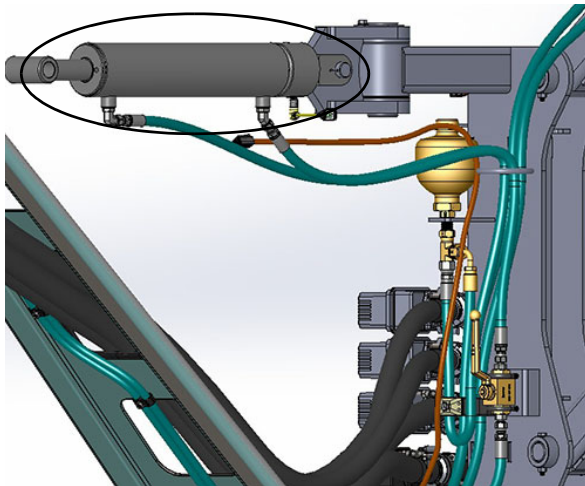

Level Cylinder  
-Typical View

### NORAC Sensors

#### CAUTION

Placing an object beneath the NORAC Sensors when the system is in automatic mode may result in unintended movement.

The boom is equipped with five (5) NORAC Sensors (two located on each outer boom fold extension and one located on the transom) that measure boom height above ground. The sensors send a signal to the NORAC control system allowing for position corrections to keep the boom parallel to the ground and the crop, giving you a more consistent spray pattern.



NORAC Sensors  
-Typical View

### Position Sensors

The level cylinders, main fold, and outer fold cylinders are equipped with internal Position Sensors. These sensors measure the linear stroke of the cylinder, allowing the boom to be positioned correctly when in Auto Fold mode.

The required specific motions exist to provide smooth, efficient operation. The programmed positions help prevent mechanical damage to the boom due to severe imbalance, unintended contact with the ground, or improper fold sequence.

*NOTE: The Position Sensors are factory-preset and should not require calibration. Contact your local John Deere dealer if boom positioning assistance is needed.*

### Accumulators

The level cylinders (located on each side transom) are equipped with an Accumulators, which act as a “shock absorber” for the booms.

## SECTION 3 – OPERATING YOUR SPRAY BOOM

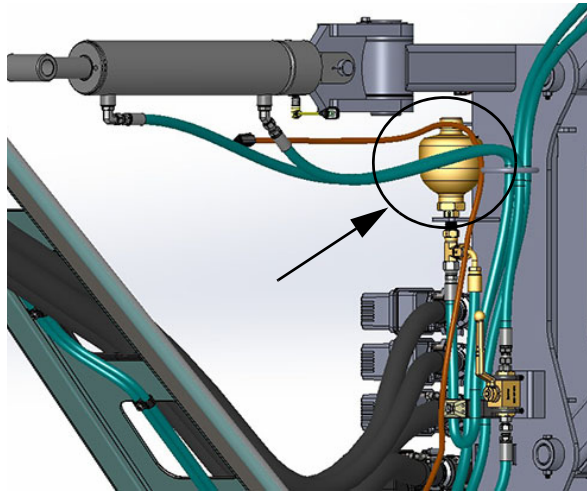

Accumulator  
-Typical View

the boom to fold forward or backward in the event that it were to come into contact with another object.

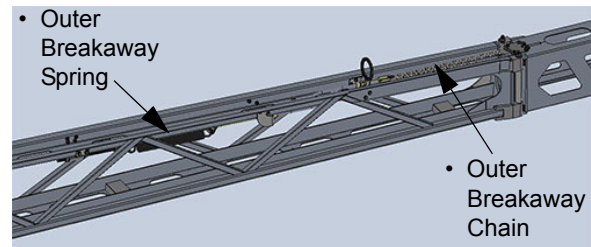

Outer Breakaway  
-Typical View

### Main Fold/Breakaway Cylinders

The Main Fold/Breakaway Cylinders are responsible for the horizontal extension of the booms to the spray position. They also provide breakaway protection for the boom. These breakaway cylinders will move backward in the event that the section encounters an obstacle.

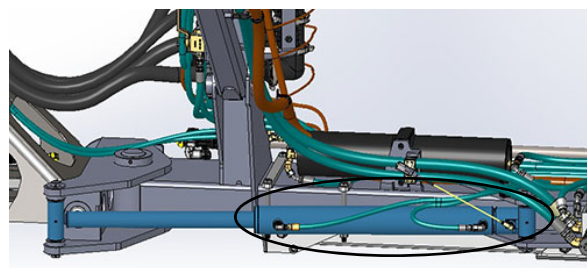

Main Fold/Breakaway Cylinder  
-Typical View

### Recharging Breakaway Circuits

In the event that the main boom fold breaks away or the machine is turned off with the boom in the spray position, a warning message will appear stating that the boom is in the spray position, but not charged. Press OK to acknowledge and recharge by pressing the corresponding Left or Right-Hand Boom Switch (located on the Hydrostatic Drive Control Handle) in the OUT position.

In addition to the boom charge warning message, a boom charge indicator will illuminate along the top of any given display page.



Boom Charge Warning

### Outer Breakaway (Tip)

A spring breakaway (located at the tip of the boom) moves forward, backward, and up to provide protection of the boom by allowing



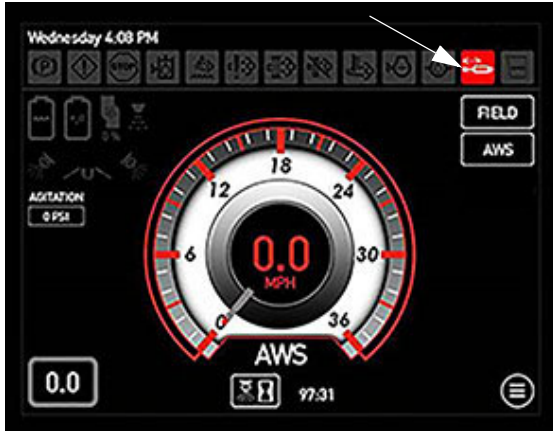

Boom Charge Indicator  
(Located along the top of each display page)

**Main Breakaway**

**To Reset the Main Breakaway**

- Once the boom has broken away, press the corresponding Left or Right-Hand Boom Switch (located on the Hydrostatic Drive Control Handle) in the OUT position momentarily to stop movement and reset the hydraulic breakaway function valve (located on center of transom).

*NOTE: The hydraulic breakaway function breaks between 3500-4350 psi (241-299 bar).*

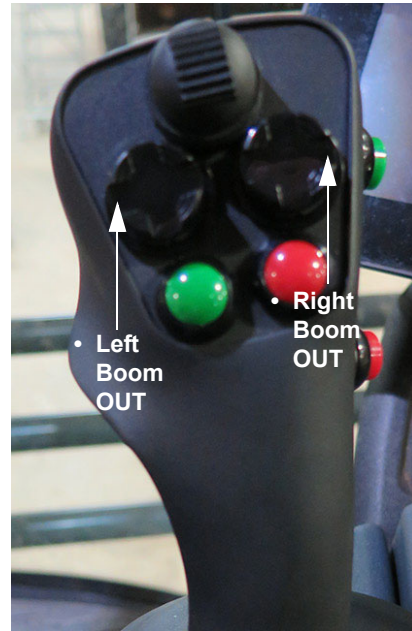

Left and Right-Hand Boom Switches  
(Located on the Hydrostatic Drive Control Handle)  
-Typical View

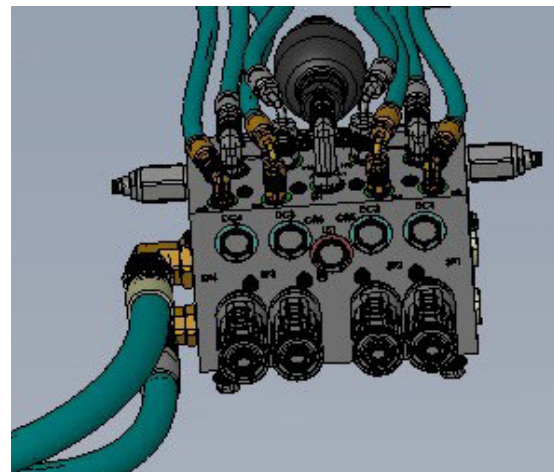

Hydraulic Breakaway Function Valve  
- Main Breakaway  
(Located on center of transom)  
-Typical View

- Press and hold the corresponding Left or Right-Hand Boom Switch in the OUT position until the main fold section has resumed spray position.

*NOTE: The main boom breakaways cannot be folded unless machine speed is less than 5 mph (8 km/h).*

## SECTION 3 – OPERATING YOUR SPRAY BOOM



### Outer Breakaway

The Outer Breakaway is self-resetting and will return to the normal operating position after it has cleared the hazard.

### Adjusting Breakaway Tension

*NOTE: Recommended tension for the spring breakaway is approximately 16”/40.6 cm (distance from the first coil to the last coil, as shown in the following illustration). Settings below 16”/40.6 cm could result in breakaway hinge damage due to excessive movement during field operation. If the breakaway springs are set to 16”/40.6 cm (2.5”/6.4 cm of stretch from resting state), exerted force by the springs is 1,100 lbs./499 kg.*

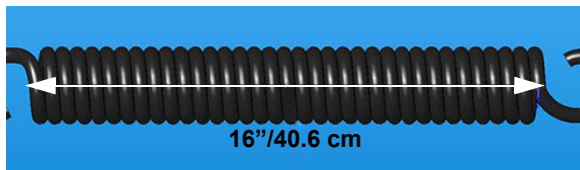

Spring Breakaway  
-Typical View

### To increase/decrease spring tension:

- Using a 15/16” wrench or socket, loosen the Jam Nut.
- Using a 15/16” wrench or socket, tighten the Adjust Nut to extend the spring, or loosen the Adjust Nut to retract the spring.
- Re-tighten Jam Nut.

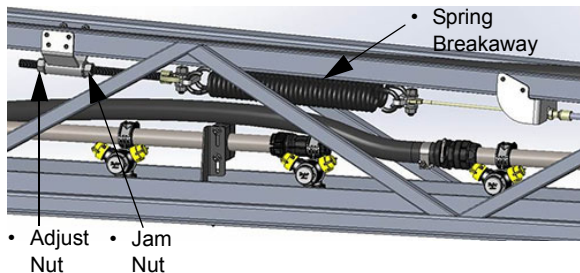

Spring Breakaway Adjust/Jam Nuts  
(Located near the outer end of the spring breakaway)  
-Typical View

### Auto Fold

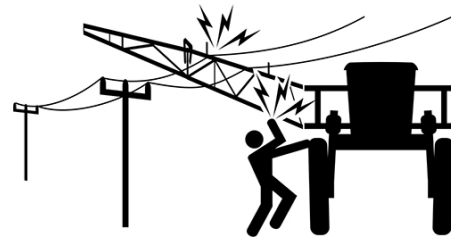

The Auto Fold feature is the preferred method for folding/unfolding the spray boom and makes operation of the machine easier for the operator.

*NOTE: Ensure the Hydrostatic Drive Control Handle is in the NEUTRAL position. If the machine is put in gear during fold operation, boom movement will stop.*

1. Press the Attachment Button (located on the Machine Display Main Menu Page) to navigate to the “Boom State” screen.



Attachment Button  
(Located on the Machine Display Main Menu Page)

2. On the “Boom State” screen, swipe the Manual/Auto Mode slide bar to AUTO.

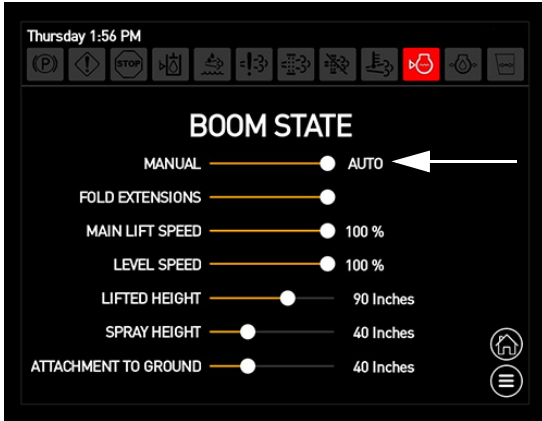

Manual/Mode  
(Located on the Boom State Screen)

- On the “Boom State” screen, swipe the Fold Extension Mode slide bar to the RIGHT (On) position to enable Auto Fold operation of the outer fold extensions.

*NOTE: Fold Extensions must be activated to enable Auto Fold operation of the outer fold sections.*

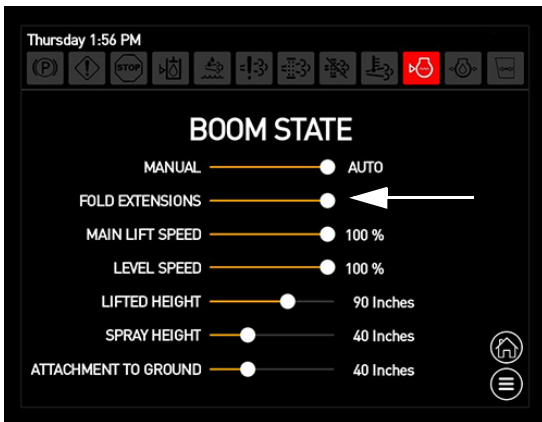

Fold Extension Mode  
Boom State Screen

When “Auto” and “Fold Extensions” are activated, the boom will operate with the left and right Boom Extension Switches (located on the side console).

*NOTE: When the Fold Extensions are disabled, the main boom will fold/unfold, but the outer fold sections will not.*

- Press and hold **both** left and right Boom Extension Switches (located on the side

console) UP to unfold the boom to the fully extended position on all sections.

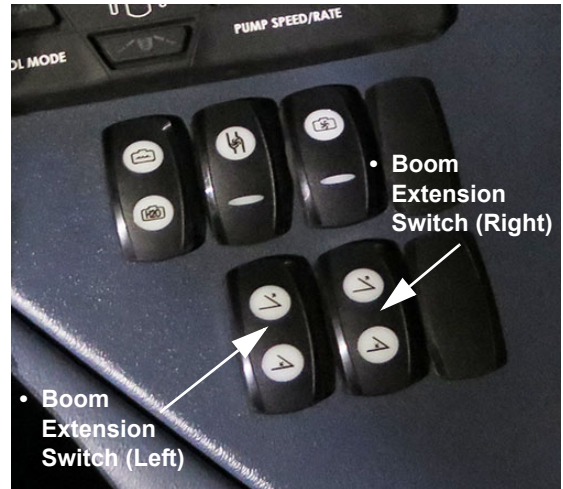

Boom Extension Switches - Left/Right  
(Located on the side console)  
-Typical View

- Press and hold **both** left and right Boom Extension Switches (located on the side console) DOWN to fold the boom in to the fully retracted position.

### Manual Fold

## NOTICE

Do not move the transom up or down during boom fold procedure. Failure to comply may result in severe damage to the boom wing structures.

## NOTICE

Do not lower the main lift while the boom is in cradle. Failure to comply will result in property damage.

## SECTION 3 – OPERATING YOUR SPRAY BOOM



### Manual Unfold (Extend)

**NOTE:** Ensure the Hydrostatic Drive Control Handle is in the NEUTRAL position. If the machine is put in gear during fold operation, boom movement will stop.

1. Press the Attachment Button (located on the Machine Display Main Menu Page) to navigate to the “Boom State” screen.



Attachment Button  
(Located on the Machine Display  
Main Menu Page)

2. On the “Boom State” screen, swipe the Manual/Auto Mode slide bar to MANUAL.

**NOTE:** When Manual Mode is activated, Fold Extensions will be disabled.

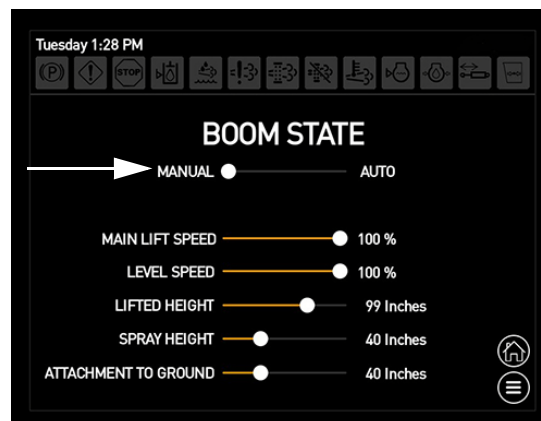

Manual/Auto Mode  
(Located on the Boom State Screen)

3. Press and hold the corresponding Left and Right-Hand Boom Switches (located on the Hydrostatic Drive Control Handle) in the UP position to raise the level cylinders all the way up.

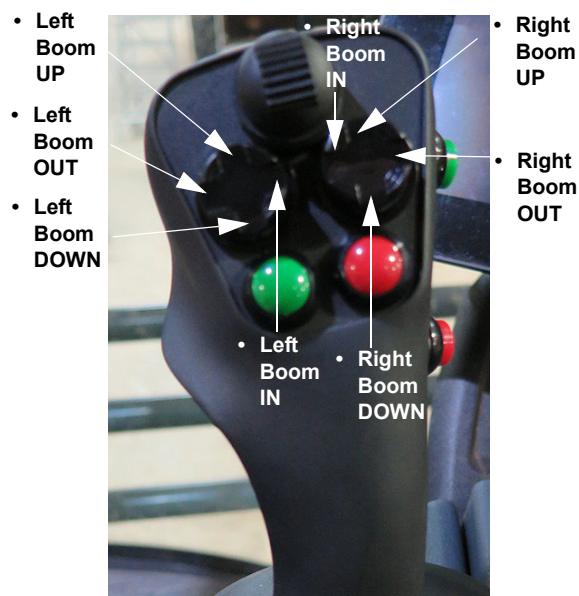

Left and Right-Hand Boom Switches  
(Located on the Hydrostatic  
Drive Control Handle)  
-Typical View

4. Press and hold the Left and Right-Hand Boom Switches in the OUT position to unfold the main boom sections until they come to a complete stop.

**NOTE:** Unfold booms simultaneously to prevent weight imbalance.

5. Lower the level cylinders until the boom is parallel with the ground.
6. Press and hold the left and right Boom Extension Switches (located on the side console) in the UP position to unfold the boom extensions all the way OUT.

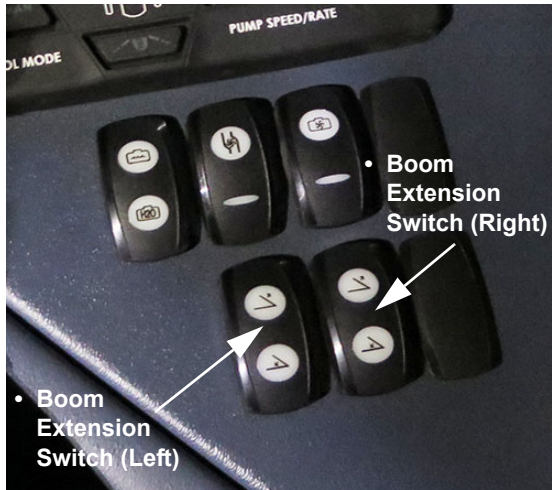

Boom Extension Switches - Left/Right  
(Located on the side console)  
-Typical View

### Manual Fold (Retract)

*NOTE: Ensure the Hydrostatic Drive Control Handle is in the NEUTRAL position. If the machine is put in gear during fold operation, boom movement will stop.*

1. On the “Boom State” screen, ensure the boom state is in Manual Mode.

*NOTE: When Manual Mode is activated, Fold Extensions will be disabled.*

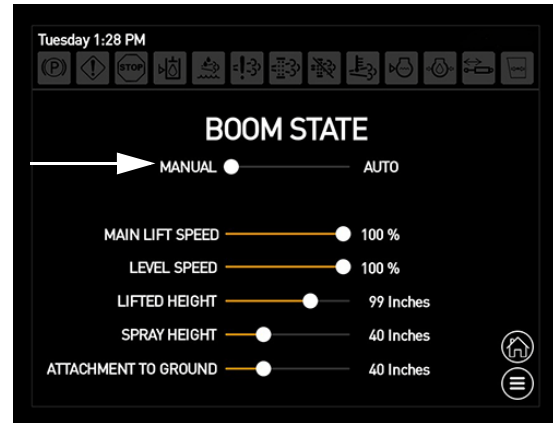

Boom State Screen - Manual Mode

2. Lower the level cylinders until the boom is parallel with the ground.
3. Press and hold the left and right Boom Extension Switches (located on the side console) in the DOWN position to fold the boom extensions all the way IN.

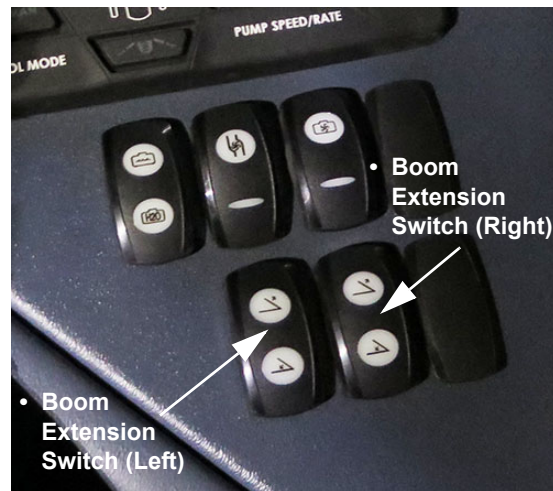

Boom Extension Switches - Left/Right  
(Located on the side console)  
-Typical View

4. Press and hold the Transom Switch (located on the Hydrostatic Drive Control Handle) in the UP position to raise the main lift all the way up.

## SECTION 3 – OPERATING YOUR SPRAY BOOM



Transom Switch - UP  
(Located on the Hydrostatic  
Drive Control Handle)  
-Typical View

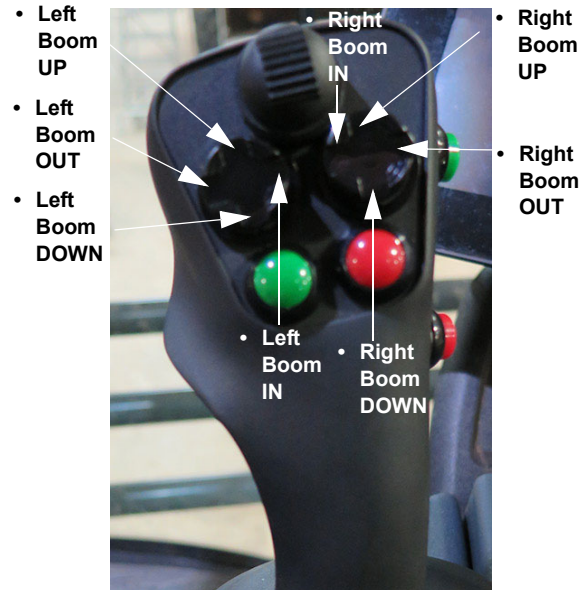

Left and Right-Hand Boom Switches  
(Located on the Hydrostatic  
Drive Control Handle)  
-Typical View

5. Raise the level cylinders until the boom wings are slightly above level.
6. Press and hold the Left and Right-Hand Boom Switches (located on the Hydrostatic Drive Control Handle) in the IN position until the main boom wings are aligned with cradles.

*NOTE: Fold booms simultaneously to prevent weight imbalance.*

7. Lower the level cylinders until the boom sections are seated in the boom cradles.

### Main Lift Speed

Main Lift Speed is the speed in which the transom travels up and down.

- On the “Boom State” screen, use the slide bar (next to Main Lift Speed) to adjust to desired speed.

*NOTE: The higher the percentage, the faster the main lift will move. The lower the percentage, the slower the main lift will move.*

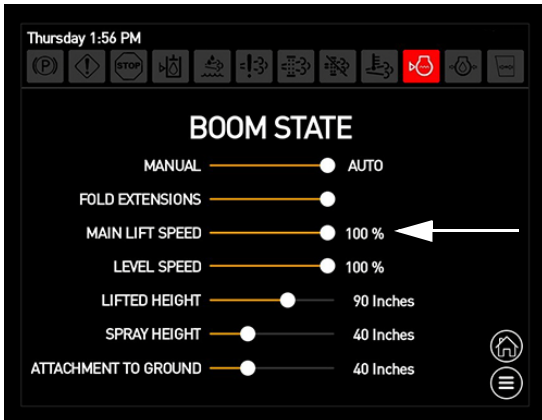

**Main Lift Speed**  
(Located on the Boom State Screen)

### Level Speed

Level Speed is the speed in which the boom wings travel up and down.

- On the “Boom State” screen, use the slide bar (next to Level Speed) to adjust to desired speed.

*NOTE: The higher the percentage, the faster the boom wings will move. The lower the percentage, the slower the boom wings will move.*

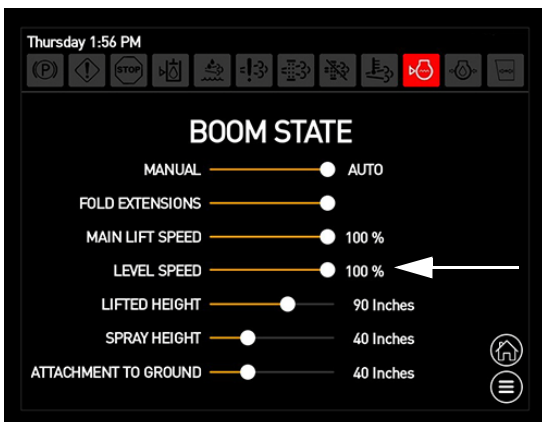

**Level Speed**  
(Located on the Boom State Screen)

### Return to Height

**(Lifted Height, Spray Height, and Attachment to Ground)**

The Return to Height feature allows the operator to raise the boom to a specified height when the End Row Management

Switch (located on the Hydrostatic Drive Control Handle) is depressed. The switch will toggle between the “spray” and “lifted” positions each time that it is pressed.

A Return to Height indicator arrow (located on the Machine Display Home Page - Field Mode) will illuminate DOWN when in the “spray” position, and UP when in the “raised” position.

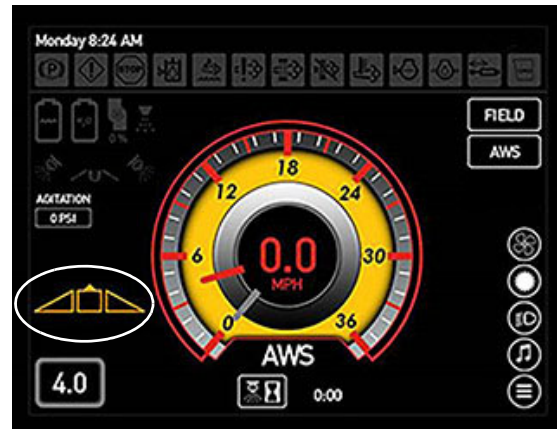

**Return to Height Indicator - UP**  
(Located on the Machine Display Home Page - Field Mode)

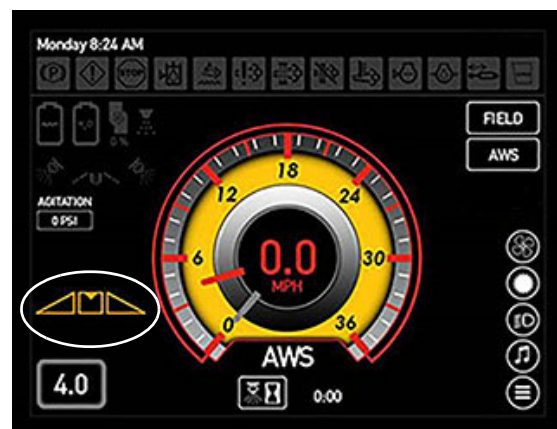

**Return to Height Indicator - DOWN**  
(Located on the Machine Display Home Page - Field Mode)

*NOTE: If the Transom Switch (located on the Hydrostatic Drive Control Handle) is depressed (or Auto Fold is enabled), the boom will resume to the “spray” position the next time that the End Row Management Switch is pressed.*

## SECTION 3 – OPERATING YOUR SPRAY BOOM



Refer to the “End Row Management” information elsewhere in this section for programming Return to Height through the End Row Management Switch.

### Return to Height Settings

#### Lifted Height

Lifted Height is the raised boom height position measured from nozzle to ground.

- On the “Boom State” screen, use the slide bar (next to Lifted Height) to adjust to desired value.

*NOTE: Swipe slide bar to the right to increase value, or to the left to decrease value.*

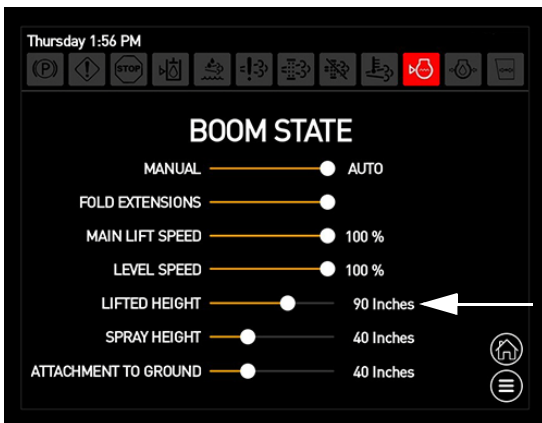

Lifted Height  
(Located on the Boom State Screen)

#### Spray Height

Spray Height is the height that the operator would like the boom to be when spraying (nozzle-to-ground distance).

*NOTE: In Auto Fold “Out” mode, the boom will lower to this setting.*

- On the “Boom State” screen, use the slide bar (next to Spray Height) to adjust to desired value.

*NOTE: Swipe slide bar to the right to increase value, or to the left to decrease value.*

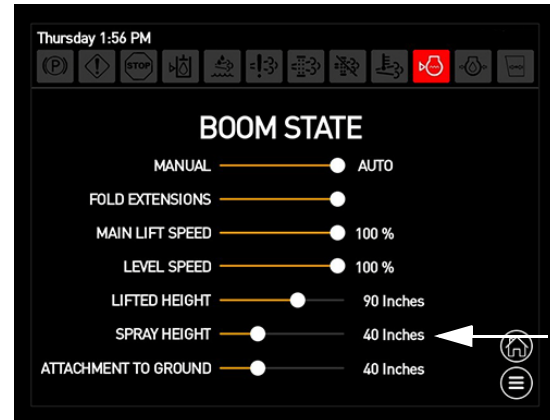

Spray Height  
(Located on the Boom State Screen)

#### Attachment to Ground

Attachment to Ground is the height from the spray nozzle-to-ground with the boom in its lowest position.

*NOTE: Attachment to Ground is measured by the operator to better dial in the system if the tires are changed on the machine.*

- On the “Boom State” screen, use the slide bar (next to Attachment to Ground) to adjust to desired value.

*NOTE: Swipe slide bar to the right to increase value, or to the left to decrease value.*

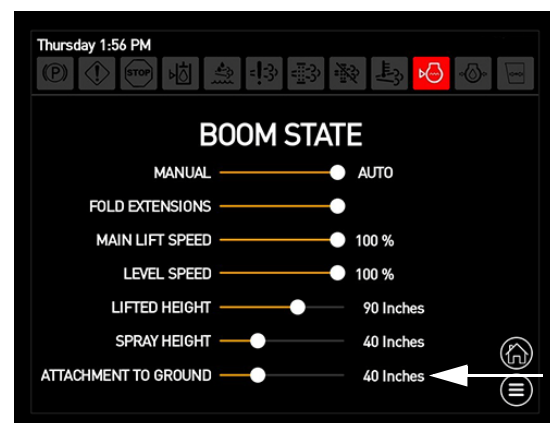

Attachment to Ground  
(Located on the Boom State Screen)



## Outer Fold Latches

### NOTICE

Do not operate the boom without full engagement of the outer fold latches. Failure to comply may result in severe structural damage of the attachment.

The spray boom is featured with Outer Fold Latches (located between the inner and outer boom sections on each side of attachment) to provide stronger joint structure and greatly extend the life of the boom.

Each Outer Fold Latch works in conjunction with the outer fold cylinder and hydraulic sequence valve to latch the inner and outer boom sections together after the boom is fully extended. These latches engage and disengage automatically when the outer fold extensions are extended and retracted by depressing the corresponding left and right Boom Extension Switches (located on the side console). Once the booms have fully extended, the outer wing pushes a poppet valve in the hydraulic sequence valve to extend the latch pins. This requires no additional input from the operator. Conversely, once the booms are folded again using the Boom Extension Switches, the hydraulic sequence valve retracts the latch pins before extending the outer fold cylinder to fold the boom.

*NOTE: The Outer Fold Latches operate in both manual and auto fold.*

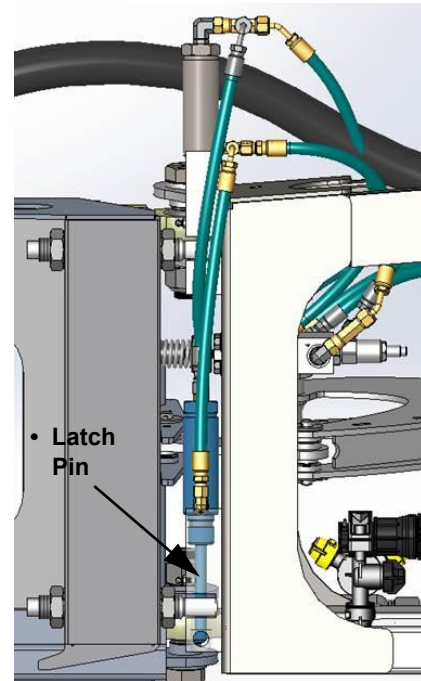

Outer Fold Latch Assembly (2)  
(Located between the inner and outer boom sections on each side of attachment)  
-Typical View

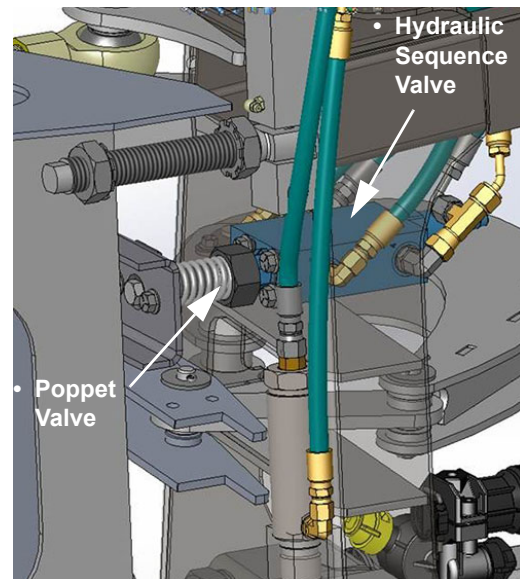

Hydraulic Sequence/Poppet Valves  
-Typical View

The spray boom is featured with a latch detection system that will notify the operator if the fold joint is unlatched while the boom is in use. In the event of a latch malfunction, a warning message will appear on the Machine

## SECTION 3 – OPERATING YOUR SPRAY BOOM



Display inside the cab. The operator should visually inspect the corresponding right or left latch pin through the access hole (located near the bottom of the inner and outer boom fold) and ensure the pin is fully engaged. Press OK (on the Machine Display warning message screen) to acknowledge before proceeding.

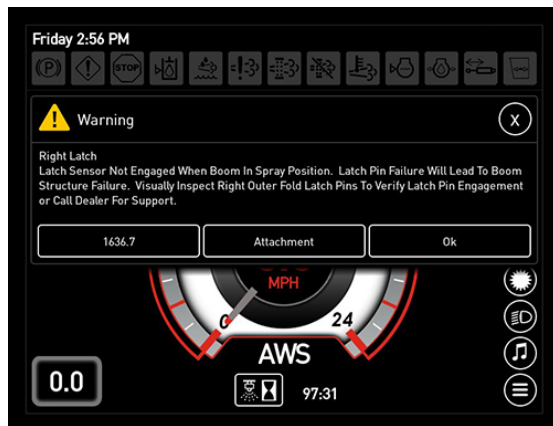

Outer Fold Latch “Not Engaged”  
Malfunction Warning

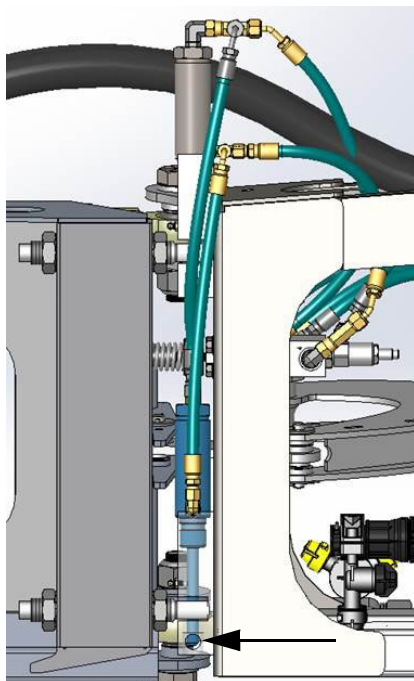

Access Hole  
(Located near the bottom of  
the inner and outer boom fold)  
-Typical View

## Transport Lock Pins

### **WARNING**

Ensure the transport lock pins are in the “transport” (locked) position before roading or trailering the machine. Failure to comply may result in property damage, personal injury, or death.

A Transport Lock Pin assembly is installed on each side of the boom (section 2) and must be in the “transport” (locked) position to prevent unintended boom movement when roading or trailering.

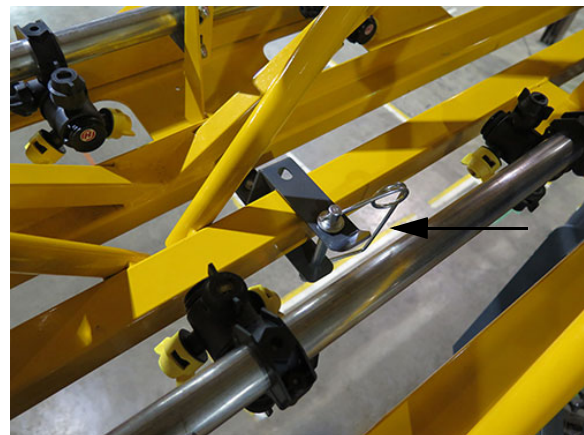

Transport Lock Pin (2)  
(Located on each side of boom - Section 2)  
-Typical View

\* Shown in the “transport” position

Refer to “Transporting” provided in the *Miscellaneous Section* elsewhere in this manual for further information.

### Enabling/Disabling NORAC® in the Precision Display

-If Equipped



Precision Display  
-Typical View

*(Your machine may vary,  
depending on available equipment)*

Upon startup, a “Waiting For Norac Home” message will appear on the Machine Display Home Page - Field Mode to alert you that the NORAC liability warning on the Precision Display must be acknowledged before proceeding.

The message will also appear if a NORAC fault is active (i.e. over-height or NORAC is on a different page other than the Precision Display NORAC Home Page). The message will disappear when the NORAC liability warning is acknowledged and the Precision Display is back on the NORAC Home Page, or if NORAC is returned to its Home Page.

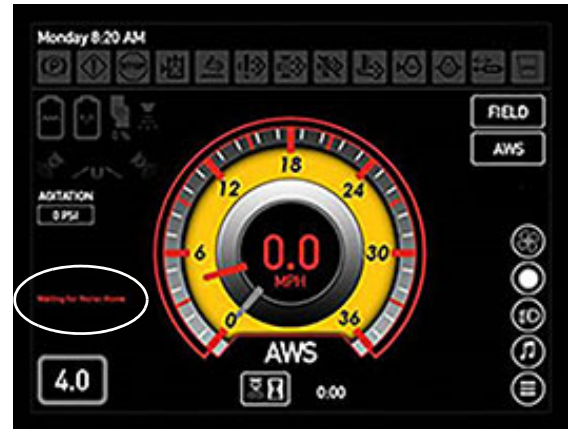

“Waiting For Norac Home” Message  
(Located on the Machine Display  
Home Page)

### Getting Started

1. On the Precision Display Home Page, press the Isobus VT (Virtual Terminal) Button.

*NOTE: The following display images may vary, depending on Precision option (i.e. John Deere Gen 4, Ag Leader, or Raven). In all options, the NORAC liability warning must be acknowledged.*

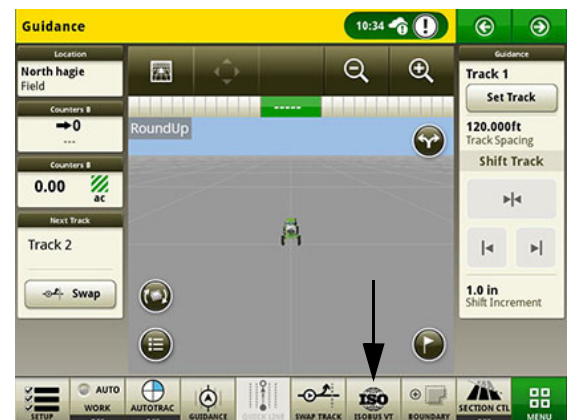

Isobus VT Button

2. On the Isobus VT Page, press the Menu Button (to allow you to select other controllers on the Isobus connection).

## SECTION 3 – OPERATING YOUR SPRAY BOOM

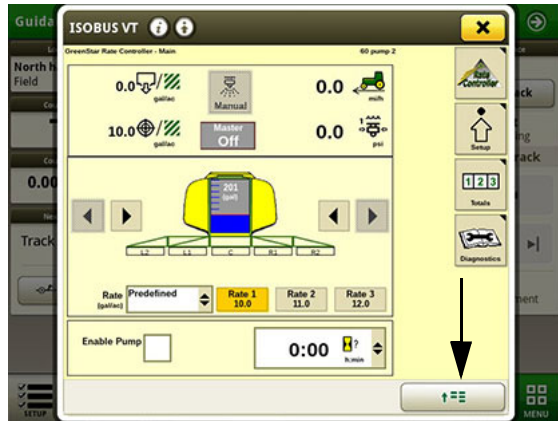

Menu Button

3. On the Connected Isobus Implements Page, select NORAC controller.

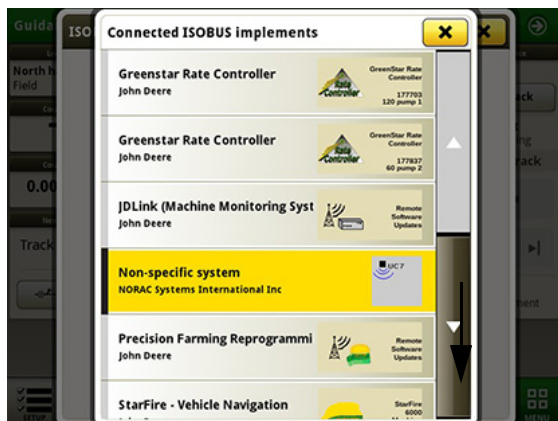

NORAC Controller Selection

4. Acknowledge the NORAC liability warning.

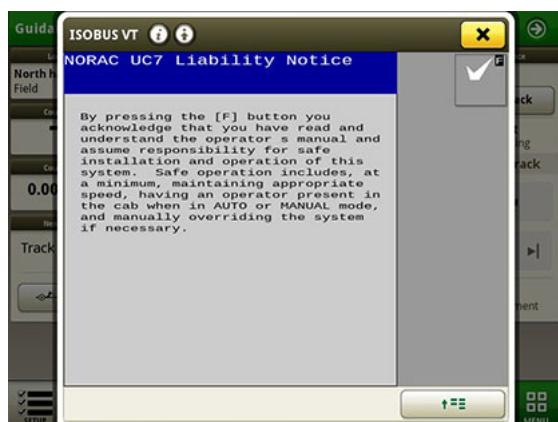

NORAC Liability Warning

*NOTE: If the liability warning does not appear, navigate to the “UC7” screen. Press the checkmark to confirm, then acknowledge liability warning.*

5. To **Enable NORAC**, press the desired Auto or Manual Button (located on the Precision Display Main Run Screen) to the ON (illuminated position).

*NOTE: In NORAC Auto Mode, if the operator is out of the seat for approximately five (5) seconds, NORAC Manual Mode will engage. To resume NORAC Auto Mode, the operator must be in the seat and reactivate NORAC Auto Mode through the Precision Display or the End Row Management Switch (located on the Hydrostatic Drive Control Handle).*

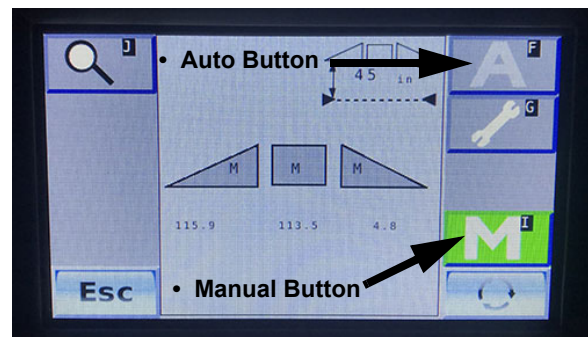

Auto/Manual Buttons  
(Located on the Precision Display  
Main Run Screen)  
-Typical View

6. When desired Manual or Auto Mode is selected, the Return to Height Indicator (located on the Machine Display Home Page - Field Mode) will illuminate. Press the “+” or “-” Button to increase or decrease NORAC height.



NORAC (Manual Mode)

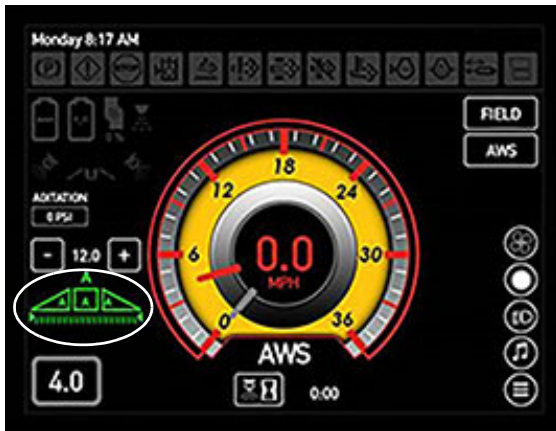

NORAC (Auto Mode)  
(All sections)

**NOTE:** If the main fold sections are folded back, NORAC Manual Mode will be engaged, and NORAC Auto Mode cannot be engaged.

- To Disable NORAC, press the corresponding Auto or Manual Button (located on the Precision Display Main Run Screen) to the OFF (non-illuminated) position.

**NOTE:** Press the Transom Switch (located on the Hydrostatic Drive Control Handle) UP or DOWN to disable the entire boom (or put the entire boom in NORAC Manual Mode). Press the Left or Right-Hand Boom Switch (located on the Hydrostatic Drive Control Handle) UP or DOWN to disable the corresponding side of the boom (or put that side of the boom in NORAC Manual Mode).

**NOTE:** The boom will also go into NORAC Manual Mode if either of the outer fold sections is folded IN with the Boom Extension (Outer Fold) Switch (located on the side console), or during Auto Fold.

**NOTE:** In the event that the NORAC System were to become inoperable, the Auto and Manual Fold functions will still operate.

### Further Information

Refer to the manufacturer's operation manual for complete operating/calibration instructions, troubleshooting information, and safety precautions.

## NORAC System Settings

**-If Equipped (Sensitivity, Soil/Crop Mode, and Target Height)**

### Sensitivity

Sensitivity is how responsive the system is. The lower the number, the lower the sensitivity. The higher the number, the higher the response time and hydraulic demand.

**NOTE:** Default sensitivity setting is 5.

### On the Precision Display:

- Press the Settings Button (wrench icon) (located on the Main Run Screen) to navigate to the Settings Screen.



Settings Button  
(Located on the Main Run Screen)  
-Typical View

- Press the cell (next to "Sensitivity") and increase or decrease system sensitivity value from 1-10.

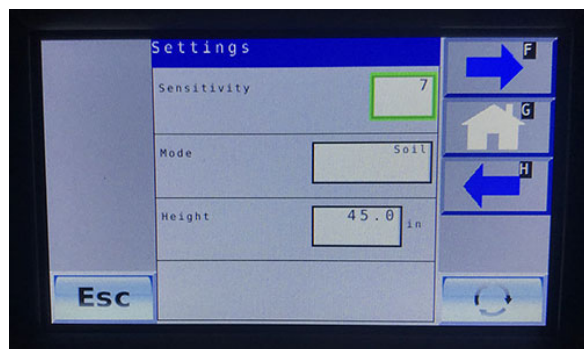

Settings Screen  
-Typical View

### Soil/Crop Mode

Soil Mode allows the sensors to read the height from the spray nozzles to the ground. Crop Mode allows the sensors to read the height from the spray nozzles to the top of the crop canopy.

#### On the Precision Display:

- Press the Settings Button (wrench icon) (located on the Main Run Screen) to navigate to the Settings Screen.
- Press the cell (next to “Mode”) and select Soil, Crop, or Hybrid.

*NOTE: Hybrid Mode is an improved Crop Mode, which uses a combination of the crop and soil readings to improve control. This setting is recommended in place of Crop Mode.*

### Target Height

Target Height is the height you desire the boom to be set at when spraying.

*NOTE: When operating in Soil Mode, the Target Height is measured from the spray nozzles to the soil. In Crop Mode, the target height is measured from the crop canopy to the spray nozzles.*

#### On the Precision Display:

- Press the Settings Button (wrench icon) (located on the Main Run Screen) to navigate to the Settings Screen.
- Press the cell (next to “Height”) and increase or decrease value to desired boom height.

### Further Information

Refer to the manufacturer’s operation manual for complete operating/calibration instructions, troubleshooting information, and safety precautions.

Refer to “Specifications” provided in the *Introduction Section* elsewhere in this manual for information on GPS dimensions on your machine.

### Enabling NORAC through the End Row Management Switch

#### -If Equipped

1. Program the End Row Management Switch (located on the Hydrostatic Drive Control Handle) through the Machine Display.  
*Refer to “Machine Display” provided in the Cab Section elsewhere in this manual for initial setup instructions.*



End Row Management Switch  
(Located on the Hydrostatic  
Drive Control Handle)  
-Typical View

2. Press the Settings Button (wrench icon) (located on the Precision Display Main Run Screen) to navigate to the Settings Screen.



Settings Button  
(Located on the Precision Display  
Main Run Screen)  
-Typical View

- On the Settings Screen (1/3), press the “right/forward” blue arrow icon to navigate to the next screen.

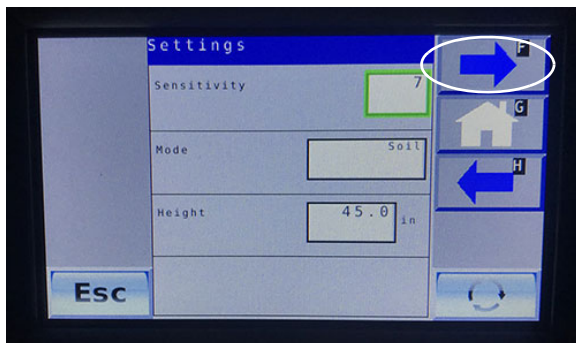

Settings Screen (1/3)  
-Typical View

- On the Settings Screen (2/3), press the “right/forward” blue arrow icon to navigate to the next screen.
- On the Settings Screen (3/3), press the “check page” icon.



Settings Screen (3/3)  
-Typical View

- On the Options Screen, ensure the “Remote Switches” option is selected.

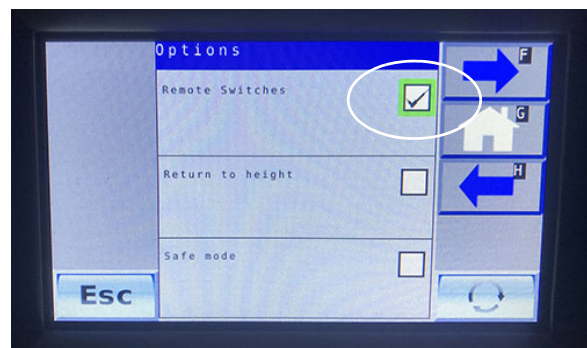

Options Screen  
-Typical View

## FENCE ROW APPLICATOR

### To Operate the Fence Row Nozzles

*NOTE: Boom Solution Valves 1 or 9 must be in the ON position in order to enable the Fence Row Switches.*

- Press the desired Fence Row Switch - Left or Right (located on the side console) to turn ON. Press switch again to turn OFF.

*NOTE: The corresponding Fence Row Switch (located on the side console) and Fence Row Indicator (located on the Machine Display Home Page - Field Mode) will illuminate when active.*

## SECTION 3 – OPERATING YOUR SPRAY BOOM

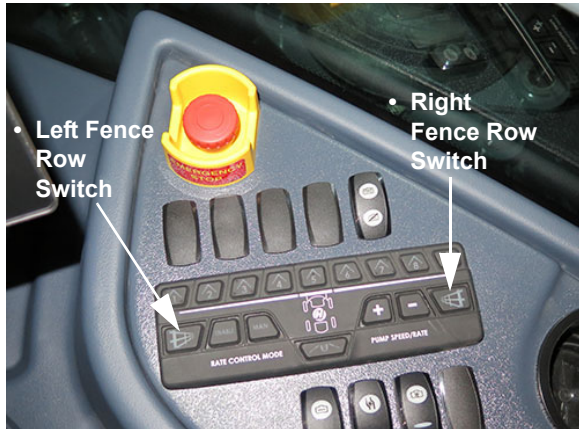

Fence Row Switches - Left and Right  
(Located on the side console)  
-Typical View

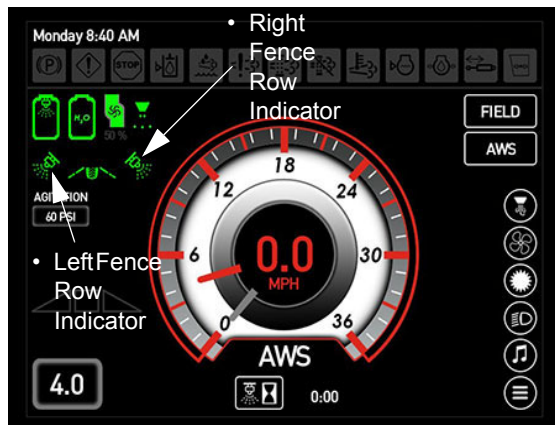

Fence Row Indicators - Left/Right  
(Located on the Machine Display  
Home Page - Field Mode)

**NOTE:** The Rear Nozzle Switch (located on the side console) and Rear Nozzle Indicator (located on the Machine Display Home Page - Field Mode) will illuminate when active.



Rear Nozzle Switch  
(Located on the side console)  
-Typical View

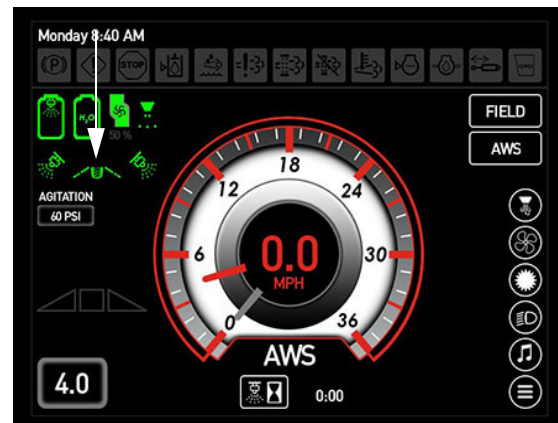

Rear Nozzle Indicator  
(Located on the Machine Display  
Home Page - Field Mode)

### To Operate the Rear Nozzles

**NOTE:** The center section of the boom must be in the ON position in order to enable the Rear Nozzles.

**NOTE:** The rear track nozzle is only activated if the Rear Nozzle Switch is depressed and Section 5 is ON.

The Rear Nozzle Switch (located on the side console) controls the two (2) rear nozzles (located behind the tires).

- Press the Rear Nozzle Switch to turn ON. Press switch again to turn OFF.





## SECTION 4 – MAINTENANCE AND STORAGE

### SERVICE - LUBRICATION

#### NOTICE

Failure to properly lubricate pivot and friction points may result in unnecessary wear and damage.

#### Hybrid Spray Booms

##### Outer Fold Cylinder

Lubricate the Outer Fold Cylinder Grease Zerks (one per side) weekly, or as needed.

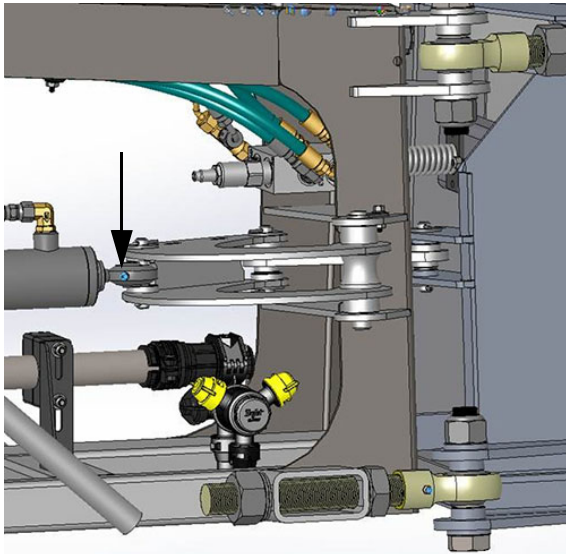

Outer Fold Cylinder Grease Zerk (2)  
-Typical View

##### Outer Fold Joint (Top/Bottom)

Lubricate the Outer Fold Joint Grease Zerks - Top/Bottom (two per side) weekly, or as needed.

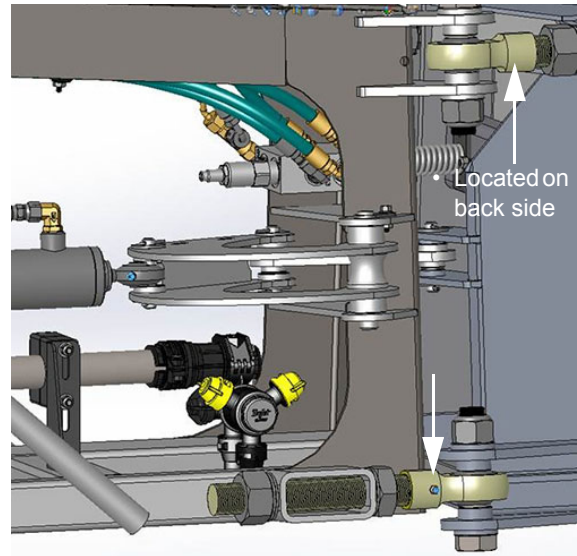

Outer Fold Joint Grease Zerks (4)  
(Top/Bottom)  
-Typical View

##### Main Fold Pivot (Upper/Lower)

Lubricate the Main Fold Pivot Grease Zerks - Upper/Lower (two per side) weekly, or as needed.

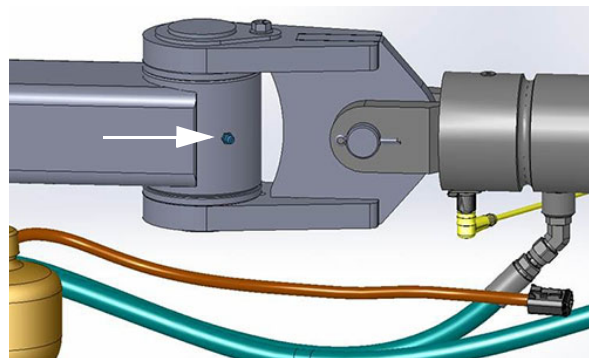

Main Fold Pivot Grease Zerk - Upper (2)  
-Typical View

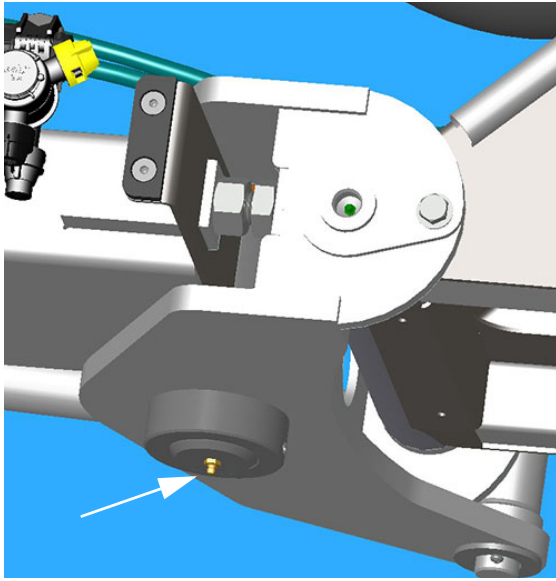

Main Fold Pivot Grease Zerk - Lower (2)  
-Typical View

**Level Pin**

Lubricate the Level Pin Grease Zerks (two per side) weekly, or as needed.

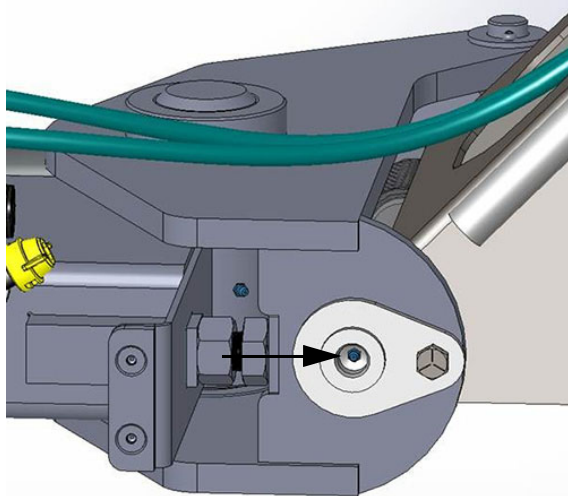

Level Pin Grease Zerk (4)  
-Typical View

**Outer Fold Latches**

Lubricate the Outer Fold Latch Grease Zerks - Top/Bottom (two per side) weekly, or as needed.

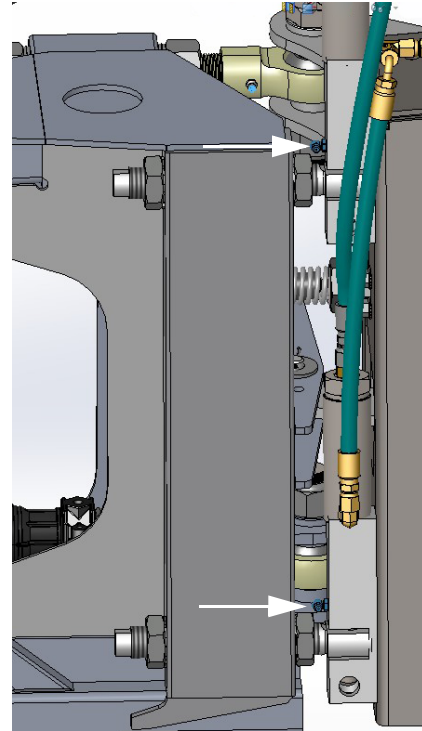

Outer Fold Latch Grease Zerks (4)  
(Top/Bottom)  
-Typical View

---

**SERVICE -  
MISCELLANEOUS**

**Spray Booms**

**Nozzle Diaphragms**

At the beginning of each season, remove each nozzle body cap (A) and inspect the diaphragm (B) for wear or fit. Replace diaphragms every 1,000 hours of operation, or as necessary.

**Spray Tips**

**⚠ CAUTION**

Never place a spray tip/nozzle to your mouth in an attempt to unplug it.

At the beginning of each season (or as required), remove a random sample of spray tip caps (C) and inspect the nozzle tips. If the tips are plugged or worn, clean or replace them. Replace spray tips every 1,000 hours of operation, or as necessary.

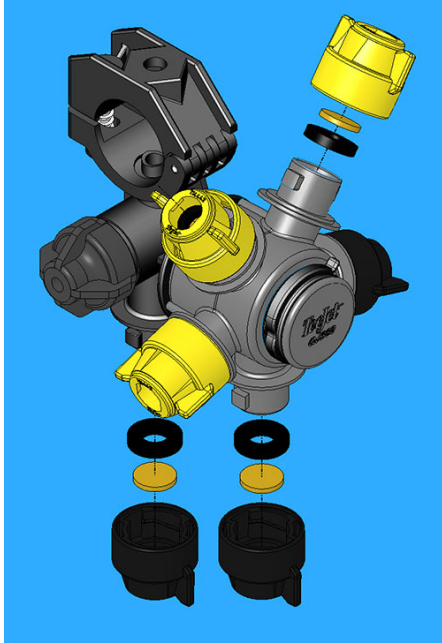

Nozzle Diaphragms and Spray Tips  
-Typical View

## SERVICE INTERVALS

90'/100'/120'/132' Hybrid Spray Boom Service Intervals				
Service Point	Daily/ Before Each Use	Weekly	As Required	1000 Hrs.
Lubricate Outer Fold Cylinder Grease Zerks		X		
Lubricate Outer Fold Joint Grease Zerks		X		
Lubricate Main Fold Pivot Grease Zerks		X		
Lubricate Level Pin Grease Zerks		X		
Lubricate Outer Fold Latch Grease Zerks		X		
Check Spray Nozzle Diaphragms and Tips			X	
Change Spray Nozzle Diaphragms and Tips				X

## STORAGE

### Preparing For Storage

1. Perform daily and weekly lubrication and maintenance inspections, as required.
2. With the engine at normal operating temperature, cycle all the hydraulic functions.
3. Thoroughly rinse the spray system.

*NOTE: Refer to your machine operator's manual for further information.*

4. Thoroughly wash the attachment and touch up any chipped or damaged paint.
5. Replace any damaged or missing decals.

*NOTE: Contact your local John Deere dealer for paint touch-up recommendations and decal replacement.*

6. Apply multi-purpose grease to hydraulic cylinder rods.
7. Refer to the spray system console manufacturer's operation manual for detailed information on monitor and flow meter storage procedures.
8. If the boom attachment will be stored separately, ensure that all open ends

(e.g. hydraulic, electrical, solution, and foam marker, if equipped) are capped or covered with a suitable covering.

### Winterization Procedure

To winterize the boom, it is recommended that you use an environmentally safe type of antifreeze and water mixture that will give you adequate protection to -30 degrees.

Drain any remaining solution in the system and rinse thoroughly. Run antifreeze mixture through the system until it comes out all attachment openings.

### Removal From Storage

## NOTICE

Protective compounds such as grease can harden under exposure to weather conditions. Be sure to remove any dried grease and reapply new, if necessary.

1. Remove any dried grease from the cylinder rods and re-apply, if necessary.
2. Thoroughly clean the boom attachment.

3. Carefully unseal any openings that were sealed for storage.
4. Attach boom to the sprayer and manually cycle the hydraulics two or three times to adequately lubricate components.



## SECTION 5 – MISCELLANEOUS

### TRANSPORTING

#### Transporting Your Machine with an Attachment

#### **⚠ WARNING**

- Never operate the sprayer on a public roadway with solution in the tank.
- Never load or unload the sprayer with solution in the tank.
- Stopping the sprayer on trailer ramps may result in the sprayer to tip over.

#### **⚠ WARNING**

When transporting the sprayer, observe the following to avoid serious injury or death:

- Check for adequate clearance before driving under any overhead obstructions.
- Contact with power lines may result in serious injury or death.



#### **⚠ CAUTION**

Ensure there is adequate clearance when transporting the sprayer near an object with clearance less than the transporting height and width of the overall machine and boom attachment.

#### **⚠ CAUTION**

Avoid collisions. Before transporting machine on a public roadway, check and follow local regulations regarding size limits, the use of lights, flags, signs, pilot vehicles, and other requirements for transporting loads using trailer.

#### **⚠ CAUTION**

Ensure the booms are folded and in cradles before transporting the machine. Failure to comply may result in injury or equipment damage.

#### **⚠ CAUTION**

DO NOT operate the machine at speeds exceeding 20 mph (32 km/h) with solution in the tank. Operating speeds exceeding 20 mph (32 km/h) with a fully loaded tank may result in tire blow-out or wheel hub damage and will void the warranty.

#### Cradling the Booms

#### **⚠ CAUTION**

Booms must be in the FOLDED position when cradled. Failure to comply will result in property damage.

*NOTE: Always cradle the booms before traveling, transporting, or parking for an extended period of time.*

- Fold the outer boom extensions IN.
- Raise the transom all the way UP.
- Fold main boom sections IN toward the machine.

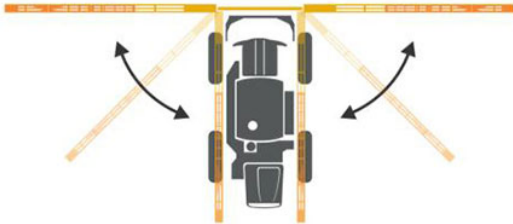

*NOTE: When boom reaches the last 8-10 degrees of travel, it will automatically slow down to avoid impact with the cradle.*

- Raise each individual boom until it clears the outer cradle stop.
- Fold the boom IN toward cradle back-stop.
- When boom touches the back-stop, lower until the full weight of the boom rests in the cradle.

## Transport Lock Pins

A Transport Lock Pin assembly is installed on each side of the spray boom (section 2) and must be in the “transport” (locked) position to avoid unintended boom movement when roading or trailering the machine.

### **WARNING**

Ensure the transport lock pins are in the “transport” (locked) position before roading or trailering the machine. Failure to comply may result in property damage, personal injury, or death.

### **NOTICE**

Ensure the transport lock pins are in the “stored” (unlocked) position before unfolding the booms. Failure to comply may result in property damage.

### **NOTICE**

In the event that the transport lock pin(s) become misplaced or lost, ensure the boom is secured in some other way before transporting and contact your local John Deere dealer for replacement.

## Locking the Boom for Transport

1. Remove the Transport Lock Pin (located in the mounting bracket on section 2) and move from the “stored” (unlocked) position to the “transport” (locked) position.



Transport Lock Pin  
(Shown in the “**stored**” position)  
-Typical View



Transport Lock Pin  
(Shown in the “transport” position)  
-Typical View

2. Ensure the bottom side of lock pin is fastened.
3. Repeat on opposite side of boom.

### Unlocking the Boom for Use

Reverse steps by moving the Transport Lock Pins from the “transport” (locked) position to the “stored” (unlocked) position.

### Driving the Sprayer on a Public Roadway

1. Ensure the booms are in the folded/cradled position and the boom transport lock pins are in the “transport” (locked) position.
2. Transport machine at narrowest tread adjust setting only.
3. Use the flashing hazard/warning lights, day or night to warn other drivers, unless prohibited by law.
4. Know and obey all state laws for driving agricultural equipment on a public roadway.
5. Adjust machine speed to suit the conditions.
6. Slow down and use turn signals before turning.
7. Pull over to the side of the road before stopping.
8. Keep a proper lookout and maintain control of the machine.

9. Do not drive under trees, bridges, wires, or other obstructions unless there is adequate clearance.
10. Use extra care before entering or exiting a public roadway.
11. Ensure the SMV (Slow Moving Vehicle) and SIS (Speed Indicator Symbol) emblems are properly displayed to warn other drivers, unless prohibited by law.
12. Do not drive the machine at speeds exceeding 20 mph (32 km/h) with solution in the tank. Operating speeds exceeding 20 mph (32 km/h) with a fully loaded tank may result in tire blow-out or wheel hub damage and will void the warranty.

## Transporting Machine Using Trailer

### Loading

#### **WARNING**

Keep all persons away from trailer when loading or unloading the sprayer. Failure to comply may result in serious injury or death.

#### **NOTICE**

Read and understand the trailer manufacturer’s operation manual. Hitch the trailer to the pulling vehicle according to their recommendations.

#### **NOTICE**

The loaded height and width of the trailer must conform to state law in which it is being used. Do not exceed the trailer manufacturer’s recommendations on loaded weight.



1. Pull the trailer to flat ground.
2. Apply the pulling vehicle's parking brake and turn the engine OFF.
3. Use tire chocks to keep the trailer from moving.
4. Fold the booms and lower into cradles.
5. Ensure the boom transport lock pins are in the "transport" (locked) position.
6. Lower the trailer ramps and set the ramp spacing for the machine's tread width setting.
7. Have an attendant help guide you onto the trailer.

*NOTE: Allow enough room between the sprayer and the pulling vehicle for turning.*

8. Deflate all four (4) air bags.
9. Secure the sprayer onto the trailer using the recommended securement restraints (see trailer manufacturer's operation manual).
10. Cover or remove the SMV (Slow Moving Vehicle) and SIS (Speed Indicator Symbol) emblems when traveling over 35 mph (55 km/h).

### Unloading

1. Pull the trailer to flat ground.
2. Apply the pulling vehicle's parking brake and turn the engine OFF.
3. Use tire chocks to keep the trailer from moving.
4. Lower the trailer ramps and set the ramp spacing for the machine's tread width setting.
5. Carefully release the securement restraints.
6. Re-inflate all four (4) air bags.
7. Have an attendant help guide you off of the trailer.
8. Uncover or replace the SMV and SIS emblems.

### Towing

See your machine operator's manual for further information.

## QUICK-TACH SYSTEM - SPRAY BOOMS

### CAUTION

When operating or positioning the booms, observe the following safety precautions. Failure to comply may result in injury or equipment damage.

- Do not unfold boom extension when main boom is in cradle.
- Do not operate machine with one boom wing out of cradle and the other boom wing in cradle.
- Ensure booms are folded and in cradle before transporting the machine.

### WARNING

When connecting or disconnecting the booms, observe the following safety precautions:

- Monitor both sides of the boom during fold procedure.
- Select a safe area that is solid and level before unfolding/folding the booms.
- Clear area of personnel.
- Check for overhead obstructions.
- Do not unfold or fold booms near power lines. Contact with power lines can result in serious injury or death.



**⚠ WARNING**

Turn the engine OFF before connecting/disconnecting any hoses or electrical lines. Failure to comply may result in serious injury or death.

### Connecting the Boom

1. Square up to the boom.

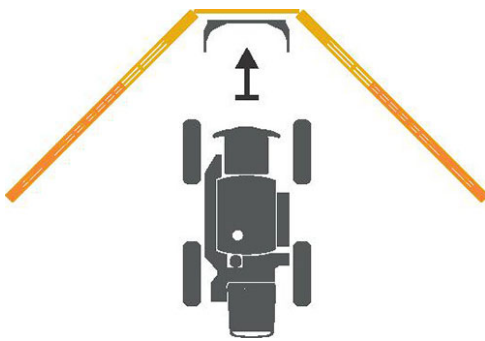

2. Disengage the Quick-Tach Lock Assemblies by pulling the Lock Pins (located on the front left and right-hand side of machine) OUT as far as it will go until it is in the “lock-out” position.

*NOTE: “Lock-out” position prevents re-locking while attaching or detaching the attachment.*

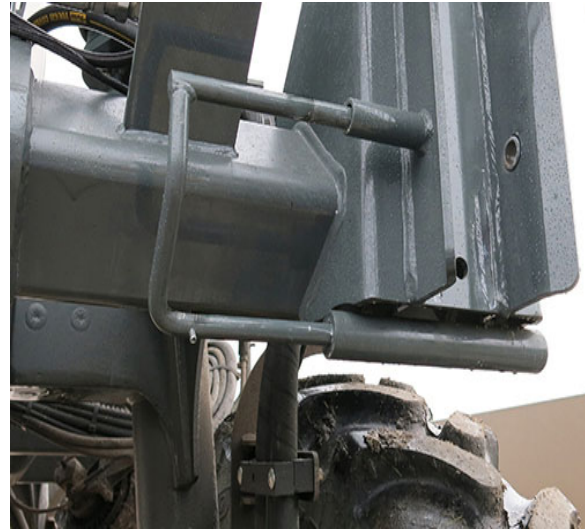

Lock Pin (2)  
(Located on the front left and right-hand side of machine)  
-Typical View  
*\* Disengaged position shown*

3. Slowly pull into the attachment.
4. Ensure the Attachment Hooks are high enough to clear the Mounting Pins.

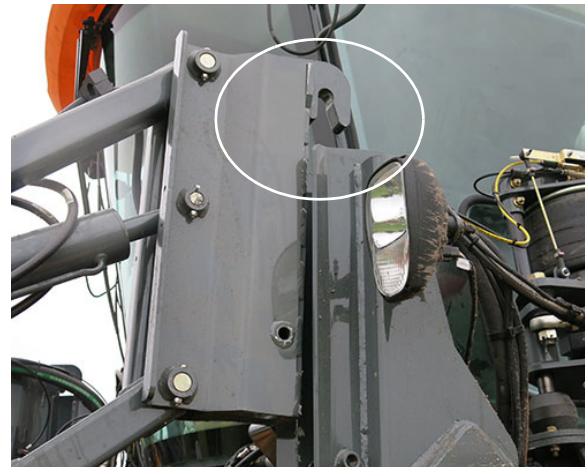

Attachment Clearing Mounting Pin  
-Typical View

5. If necessary, lower the machine by rotating the corresponding Air Suspension Valves (located on the left-hand front air bag) in the COUNTER-CLOCKWISE (Deflate) position.

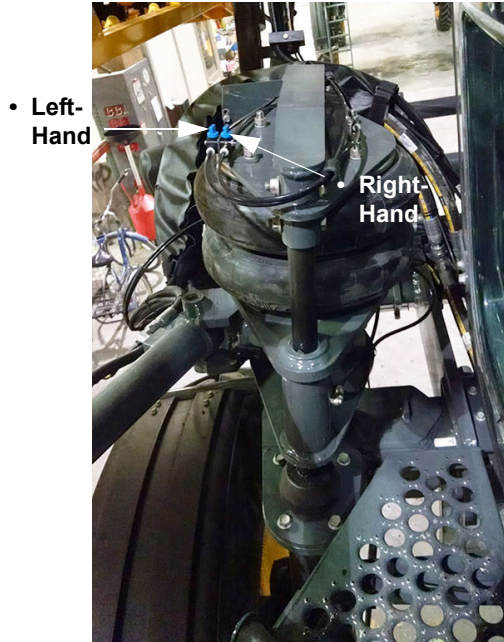

Air Suspension Valves  
(Located on the left-hand front air bag)  
-Typical View

6. Engage the parking brake.
7. **Turn the engine OFF before connecting any hoses or electrical lines!**
8. Connect all Solution, Air Bleed Valve (if equipped\*), Foam Marker (if equipped), NORAC® (if equipped), Hydraulic, and Electrical Connections.

**Solution Connections**



Solution and Air Bleed Valve Connections -  
**Standard**  
(Located on the front  
right-hand side of machine)  
-Typical View

*\* DPS machines are not equipped  
with an Air Bleed Valve*

**Dual Product System Solution  
Connections**

**-If Equipped**

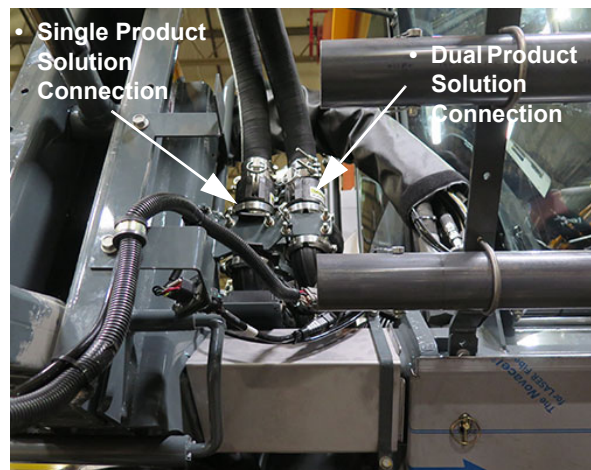

Solution Connections - **Single/Dual Product**  
(Located on the front  
right-hand side of machine)  
-Typical View

## SECTION 5 – MISCELLANEOUS



### Foam Marker Connection

-If Equipped

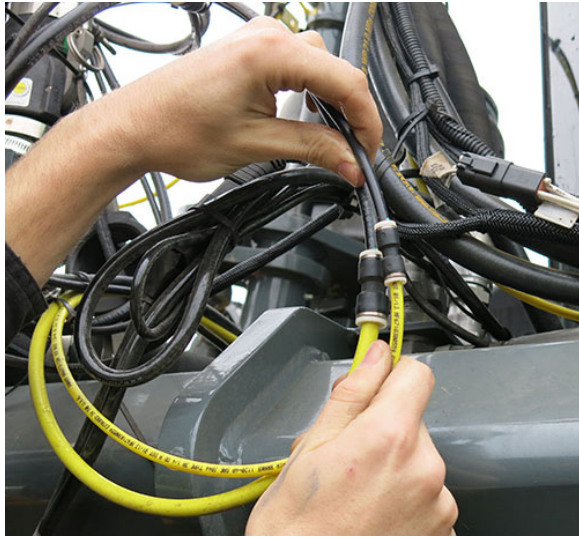

Foam Marker Connection  
(Located on the front  
right-hand side of machine)  
-Typical View

### NORAC Connection

-If Equipped



NORAC Connection  
(Located on the front  
right-hand side of machine)  
-Typical View

### Quick Connect Multi-Coupler (Hybrid Spray Booms)

-If Equipped

- Remove Hydraulic/Electric Multi-Coupler (A) from the Multi-Coupler Storage Receptacle (B) (located on the left-hand boom lift arm) and install on the front left-hand side of machine (as shown).

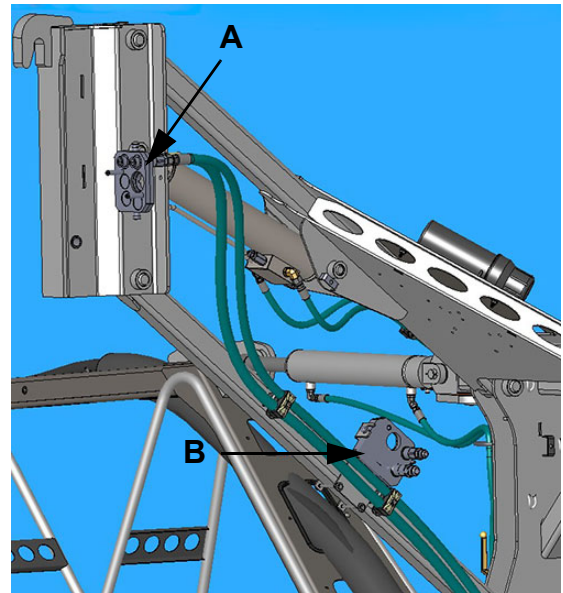

Multi-Coupler Storage Assembly  
**- if equipped**  
(Located on the left-hand boom lift arm)  
-Typical View

- Install the Hydraulic/Electrical Connections (located on the left-hand side of attachment) into the Multi-Coupler Receptacle (located on front left-hand side of machine), ensuring full engagement.
- Push the Quick Connect Handle (located on the Hydraulic/Electric Multi-Coupler Assembly) OUT to engage hydraulic/electrical connections.



Hydraulic/Electric Multi-Coupler Assembly  
- *if equipped*  
(Located on the front  
left-hand side of machine)

**Dual Product System Electrical  
Connection**  
-If Equipped

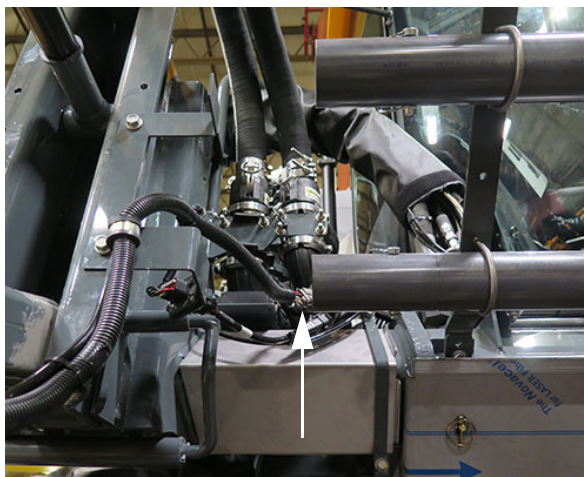

Dual Product Electrical Connection  
(Located on the front  
right-hand side of machine)  
-Typical View

9. **If equipped with NORAC**, rotate the two (2) Level Cylinder Lock Valves (one located on each left and right-hand level cylinder) in the OPEN (counter-clockwise) position.

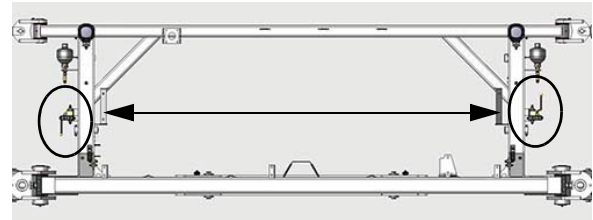

Level Cylinder Lock Valves (2)  
- Hybrid Booms  
(Located near the level cylinder  
on each side of transom)  
-Typical View

10. Start the engine.
11. If the air bags were previously deflated, raise the machine by rotating the corresponding Air Suspension Valves in the CLOCKWISE (Inflate) position.
12. Press and hold the Transom Switch (located on the Hydrostatic Drive Control Handle) in the UP position to raise the boom until the Attachment Hooks fully engage.

*NOTE: Press and hold the Transom Switch only until the Attachment Hooks become fully engaged.*



Transom Switch - UP  
(Located on the Hydrostatic  
Drive Control Handle)  
-Typical View

## SECTION 5 – MISCELLANEOUS



*NOTE: Raising the attachment will allow the weight of the boom to pull the Attachment Hooks over the Mounting Pins. You will notice a change of weight as the machine begins to support the attachment.*

- Engage the Quick-Tach Lock Assemblies by pushing the Lock Pins IN, ensuring full engagement.

*NOTE: If necessary, adjust the level cylinders to free the Lock Pins.*

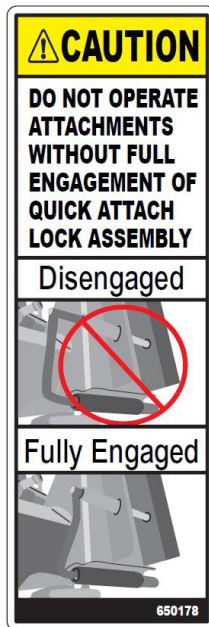

Lock Pin (2)  
-Typical View

*\* Engaged position shown*

- Place boom stands in the TRAVEL position.  
Refer to “Boom Stands” elsewhere in this section for further information.

### NOTICE

Do not operate the boom while the boom stands are in the lowered position. Failure to comply may result in property damage.

### Disconnecting the Boom

Before disconnecting the boom, determine a proper storage location. When choosing a place to store the boom, there are three important things to keep in mind:

#### Is the ground level?

The ground must be level to help prevent the attachment from falling over. Level ground will also minimize stress on the frame of the attachment when in storage.

#### Is there enough space?

The attachment needs to be partially open for it to stand properly, but be aware of the room that is needed for the attachment and adequate space to travel around it safely.

#### Is it accessible?

The attachment needs to be positioned so you can connect easily. Ensure there is enough room and that the attachment is not blocked, or blocking other items.

If temporarily storing the attachment on a soft surface (such as grass), it is recommended to place blocks or wood beneath the stands' feet to prevent the attachment from sinking into the ground.

*NOTE: It is NOT recommended to store the attachment on a soft surface for an extended period of time, due to the risk of settling soil, even when blocks or wood are used.*

### Unfolding the Boom for Storage

The booms must be partially open for stability when unattached from the machine. Unfold the booms approximately 10-20° (from folded position) while maintaining sufficient clearance for repositioning during reattachment. This position will allow the booms to sit level with the transom without causing excessive stress on either part. It will also keep the weight from shifting too much in either direction (rearward or forward), which could cause the boom to tip over and/or difficulty in connecting or disconnecting the attachment.

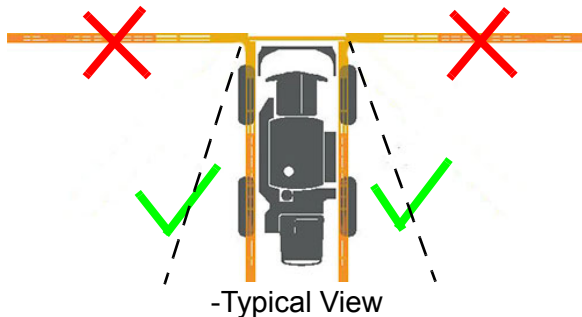

1. Press and hold the corresponding Left and Right Boom Switches (located on the Hydrostatic Drive Control Handle) in the UP position to remove boom wings from cradles.

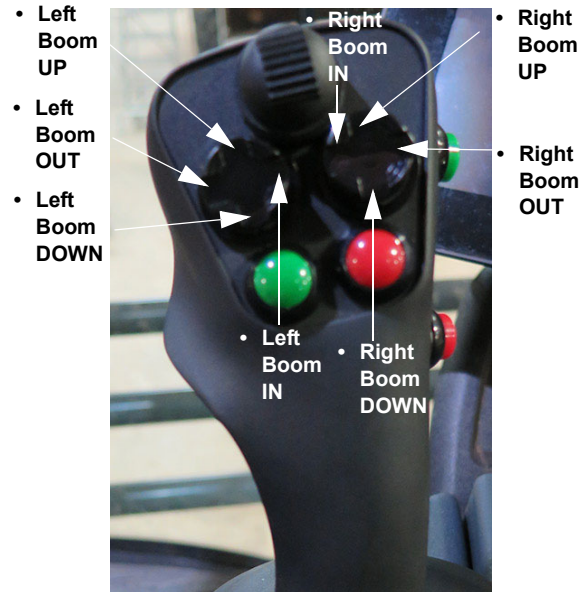

Left and Right-Hand Boom Switches  
(Located on the Hydrostatic Drive Control Handle)  
-Typical View

2. Press and hold the corresponding Left and Right Boom Switches in the OUT position to unfold the boom wings until **partially** open.
 

*NOTE: Booms only need to be unfolded far enough to clear the boom cradles and lower (e.g. enough to clear the front tires and allow room for steering to line up the boom). Do NOT fully extend.*
3. Lower the boom and secure the boom stands (if equipped) in the DOWN position.  
See “Boom Stands” elsewhere in this section for further information.

### **WARNING**

Lower boom to the ground before disengaging the Quick-Tach Lock Assemblies.

4. Press and hold the corresponding Left and Right Boom Switches in the DOWN

## SECTION 5 – MISCELLANEOUS



position to point boom tips down (until tips touch the ground).

5. Disengage the Quick-Tach Lock Assemblies by pulling the Lock Pins (located on the front left and right-hand side of machine) OUT as far as it will go until it is in the “lock-out” position.

*NOTE: “Lock-out” position prevents re-locking while attaching or detaching the attachment.*

*NOTE: If necessary, adjust the level cylinders to free the Lock Pins.*



Lock Pin (2)  
(Located on the front left and right-hand side of machine)  
-Typical View

*\* Disengaged position shown*

6. If necessary, lower the machine by rotating the corresponding Air Suspension Valves (located on the left-hand front air bag) in the COUNTER-CLOCKWISE (Deflate) position.

• Left-Hand

• Right-Hand

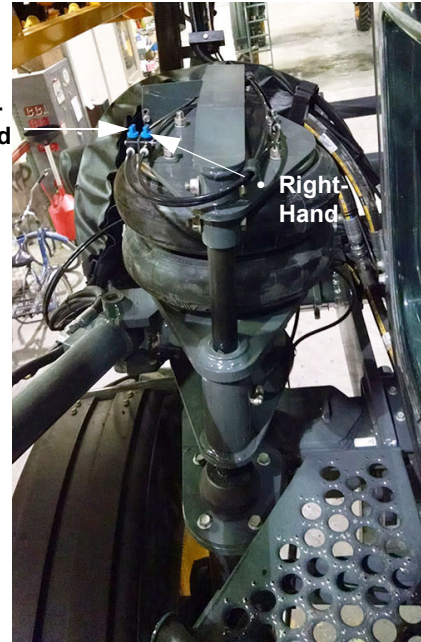

Air Suspension Valves  
(Located on the left-hand front air bag)  
-Typical View

7. Ensure the Boom Solution Valve Switches (located on the side console) are in the OFF position.



Boom Solution Valve Switches  
(Located on the side console)  
-Typical View

8. Disconnect the Solution, Air Bleed Valve (if equipped\*), Foam Marker (if equipped), and NORAC® (if equipped) Connections, ensuring not to leave the ends in an area where they may become damaged or contaminated.



**Solution Connections**

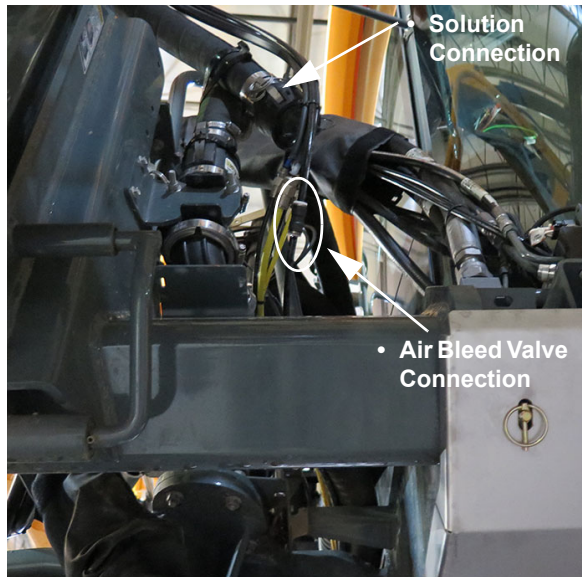

Solution and Air Bleed Valve Connections -  
**Standard**

(Located on the front  
right-hand side of machine)  
-Typical View

*\* DPS machines are not equipped  
with an Air Bleed Valve*

**Dual Product System Solution  
Connections**

-If Equipped

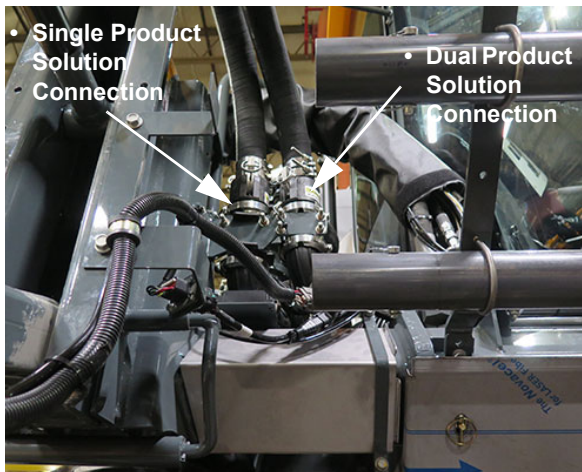

Solution Connections - **Single/Dual Product**

(Located on the front  
right-hand side of machine)  
-Typical View

**Foam Marker Connection**

-If Equipped

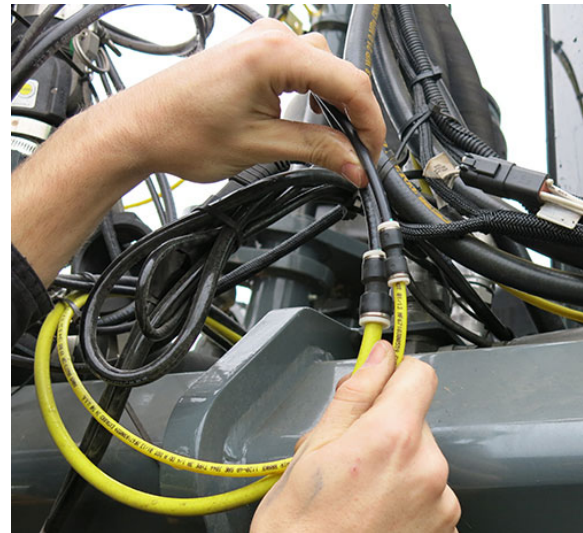

Foam Marker Connection  
(Located on the front  
right-hand side of machine)  
-Typical View

**NORAC Connection**

-If Equipped



NORAC Connection  
(Located on the front  
right-hand side of machine)  
-Typical View

9. Press and hold the Transom Switch  
(located on the Hydrostatic Drive Control)

## SECTION 5 – MISCELLANEOUS



Handle) in the DOWN position and slowly lower the boom/transom assembly until Attachment Hooks clear the Mounting Pins.



Transom Switch - DOWN  
(Located on the Hydrostatic Drive Control Handle)  
-Typical View

*NOTE: If the air bags are inflated, a “bounce back” effect may be felt when the weight of the boom has been relieved from the machine. Once the air bags have cycled, the machine will adjust to the new weight.*

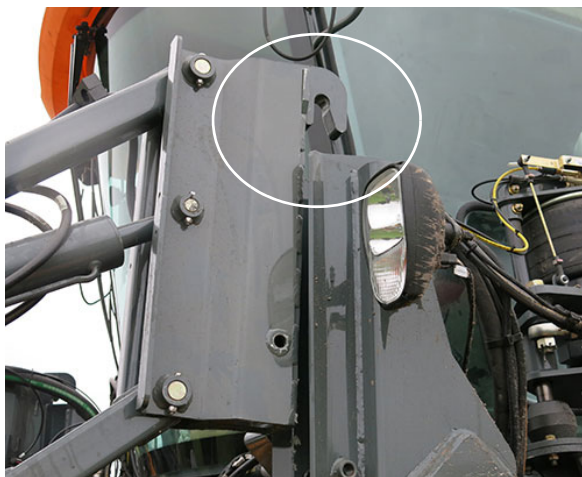

Attachment Clearing Mounting Pin  
-Typical View

10. Engage the parking brake.
11. Turn the engine OFF before disconnecting any hoses or electrical lines!
12. If equipped with a Multi-Coupler, push the Quick Connect Handle (located on the Hydraulic/Electric Multi-Coupler Assembly) IN to disengage hydraulic/electrical connections.  
If your machine is not equipped with a Multi-Coupler, proceed to Step 15.

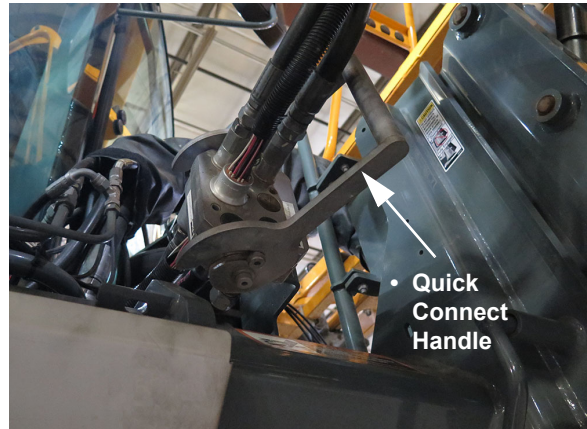

Hydraulic/Electric Multi-Coupler Assembly  
- if equipped  
(Located on the front left-hand side of machine)

13. Remove Hydraulic/Electrical Connections from the Multi-Coupler Receptacle.
14. Remove Hydraulic/Electric Multi-Coupler (A) from the front left-hand side of machine and reinstall on the Multi-Coupler Storage Receptacle (B) (located on the left-hand boom lift arm).

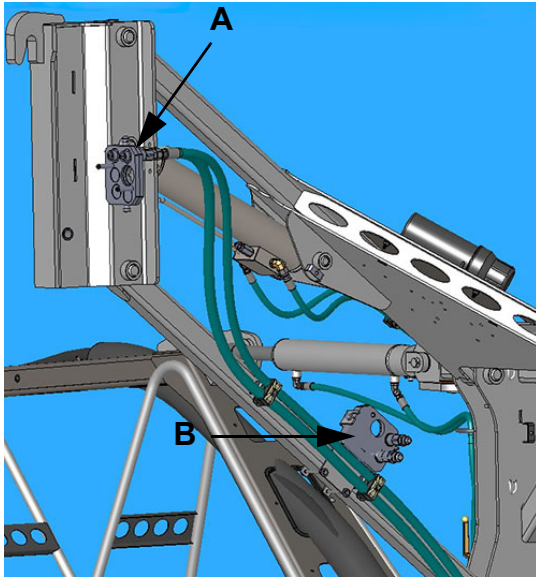

Multi-Coupler Storage Assembly  
- *if equipped*  
(Located on the left-hand boom lift arm)  
-Typical View

15. **If equipped**, disconnect the Dual Product Electrical Connection (located on the front right-hand side of machine).

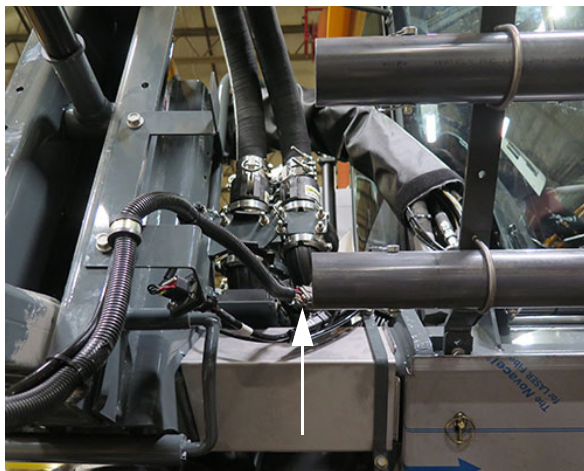

Dual Product Electrical Connection  
- *if equipped*  
(Located on the front right-hand side of machine)  
-Typical View

16. **If equipped with NORAC**, rotate the two (2) Level Cylinder Lock Valves (one located on each left and right-hand level cylinder) in the CLOSED (clockwise) position.

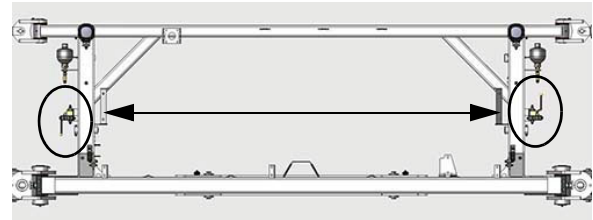

Level Cylinder Lock Valves (2)  
- Hybrid Booms  
(Located near the level cylinder on each side of transom)  
-Typical View

17. If no other attachment is going to be installed, re-lock the Quick-Tach Lock Assemblies by pushing the Lock Pins IN.  
18. Start the machine.  
19. Disengage the parking brake and slowly back away from the boom.  
20. If the air bags were previously deflated, raise the machine by rotating the corresponding Air Suspension Valves in the CLOCKWISE (Inflate) position.

## Boom Stands

### - If Equipped

Your boom may be equipped with two (2) boom stands that swing downward from the bottom of the transom.

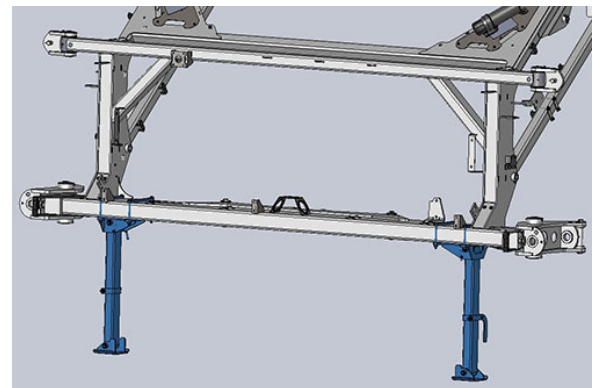

Booms Stands  
-Typical View

### To Extend Booms Stands

1. Remove Hairpin (A) from end of Lock Pin (B) (located on the outward side of boom stand) and set aside.

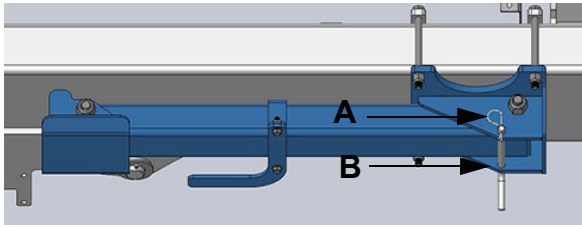

Lock Pin Assembly  
(Located on the outward  
side of boom stand)  
-Typical View

2. While supporting the bottom “foot” end of boom stand, remove Lock Pin (B) and slowly lower boom stand.
3. With the boom stand lowered, reinstall Lock Pin (B).
4. Reinstall Hairpin (A) to end of Lock Pin (B).

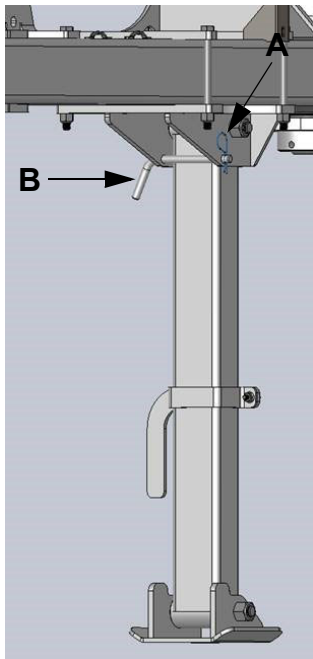

Lock Pin Reinstalled  
-Typical View

5. Repeat Steps 1-4 on opposite side of boom.
6. Reverse steps to store booms stands in “travel” position.

---

**TROUBLESHOOTING**

---

<b>Problem</b>	<b>Possible Cause</b>	<b>Suggested Remedy</b>
Boom sections will not fold in	<ul style="list-style-type: none"><li>• Operating the manual boom switches when boom state is in Auto Mode</li><li>• Position sensor error (Auto Mode is inoperable)</li></ul>	<ul style="list-style-type: none"><li>• Use the proper switches for the selected boom state</li><li>• Use manual boom switches</li><li>• Contact your local John Deere dealer for assistance</li></ul>
Boom will not recharge	<ul style="list-style-type: none"><li>• Proximity/Position Sensor error</li><li>• Software bug</li></ul>	<ul style="list-style-type: none"><li>• Check for error message on Machine Display</li><li>• Unfold each section in Manual Mode</li><li>• Contact your local John Deere dealer for assistance</li></ul>
Boom will not operate when manual boom switches are pressed	<ul style="list-style-type: none"><li>• Acknowledge power line warning on Machine Display</li></ul>	<ul style="list-style-type: none"><li>• Contact your local John Deere dealer for assistance</li></ul>
Boom up/down functions inoperable	<ul style="list-style-type: none"><li>• NORAC system not functioning properly/ communication error</li></ul>	<ul style="list-style-type: none"><li>• Check NORAC system status</li><li>• Restart machine</li><li>• Contact your local John Deere dealer for assistance</li></ul>



---

A Word From Hagie Manufacturing	
Company .....	1-1
About This Manual .....	1-1
Fence Row Applicator .....	3-25
Identification .....	1-3
Intended Use .....	2-1
Operator's Station .....	3-1
Product Warranty .....	1-3
Quick-Tach System - Spray Booms .....	5-4
Safety Decals .....	2-4
Safety Messages Used In This	
Manual .....	1-2
Safety Precautions .....	2-1
Service - Lubrication .....	4-1
Service - Miscellaneous .....	4-2
Service and Assistance .....	1-2
Service Intervals .....	4-4
Specifications .....	1-4
Spray Booms - 90/100/120/132'	
Hybrid .....	3-6
Storage .....	4-4
Transporting .....	5-1
Troubleshooting .....	5-16

# NOTES

---

# NOTES

---



# NOTES

---