



**PARTS MANUAL
FOR
HAGIE MODEL STS 12 HI-TRACTOR**

HAGIE MANUFACTURING COMPANY

721 CENTRAL AVENUE WEST
BOX 273
CLARION, IOWA 50525

COVERS MACHINE SERIAL NUMBERS: U1601221001 thru U1601221100

09-11 493532

05-12, 05-15, 02-16, 03-17

To obtain the most current parts manual for your machine, please visit www.hagiehelp.com.

© 2011-12, 2015-17 Hagie Manufacturing Company, Clarion, Iowa USA

SPRAYER IDENTIFICATION

Each Hagie sprayer is identified by means of a frame serial number.

This serial number denotes the model, the year in which it was built, and the number of the sprayer. As for further identification, the engine has a serial number and the planetary hubs have identification plates that describe the type of mount and gear ratio. To insure prompt, efficient service when ordering parts or requesting service repairs from Hagie Manufacturing Company, record the serial and identification numbers in the space provided below.

NOTE: Reference to left hand and right hand used throughout this manual refers to the position when seated in the operator's seat facing forward.

This manual is not intended to be a complete guide for machine maintenance and repairs. If you are not properly trained to perform service on this machine, contact Hagie Customer Support for assistance. Improper maintenance or repair may result in property damage, personal injury, or death.

SPRAYER SERIAL NUMBER

ENGINE SERIAL NUMBER

PLANETARY HUB IDENTIFICATION NUMBERS

FILTER QUICK REFERENCE

<u>QTY.</u>	<u>PART NO.</u>	<u>DESCRIPTION</u>
1	311543	ENGINE AIR FILTER, PRIMARY
1	311544	ENGINE AIR FILTER, SECONDARY
1	316281	FUEL STRAINER IN LINE
1	316372	ENGINE OIL FILTER
1	316683	FUEL FILTER
1	316684	REMOTE FUEL FILTER
1	605626	HYDRAULIC OIL FILTER
1	657463	CAB PAPER FILTER
1	657464	CAB CHARCOAL FILTER

TABLE OF CONTENTS

ENGINE ASSEMBLY 4-8

RADIATOR AND OIL COOLER ASSEMBLY. 9

AIR CLEANER AND EXHAUST ASSEMBLY. 10-11

FUEL AND OIL TANK ASSEMBLY. 12-13

BATTERY 14

TIRE ASSEMBLY 15

LEG ASSEMBLY 16-27

TREAD ADJUST ASSEMBLY 28-33

HYDRAULIC TUBING 34-35

HYDRAULIC MANIFOLDS 36-39

SOLUTION CONTROL AND QUICK COUPLER 40-41

LADDER AND BRAKE VALVE ASSEMBLY 42

LADDER ASSEMBLY 43

SERVICE PLATFORM. 44

TOOL BOX. 45

AIR DRIER AND AIR TANK ASSEMBLY 46-48

J1939 JUNCTION BOX. 49

CAB ASSEMBLY. 50-65

FLASHER AND LIGHT RELAY 66

REAR ELECTRICAL AND ENGINE BOX ASSEMBLY 67-68

BUMPER AND ENGINE HOOD. 69-71

SOLUTION TANK 72-73

SOLUTION HOISING 74-78

REAR WHEEL NOZZLE 79

SOLUTION PUMP 80-81

QUICK ATTACH. 82

BOOM CRADLE 83-84

FOAMER AND FRESH WATER TANK. 85-87

PRESSURE WASHER OPTION 89-90

SIDE FILL/CHEMICAL INDUCTOR OPTION 91-92

FRONT FILL OPTION 93

FENDER OPTION. 94-95

FLOW MAX 110 MONITOR 96-97

ALL WHEEL STEER OPTION. 98

AIR LINE DIAGRAM. 99

DECALS 100-101

HYDRAULIC DIAGRAM. 102-121

ELECTRICAL DIAGRAM 122-131

ABBREVIATIONS 132

INDEX 133

PARTS ORDER FORM. 137

4

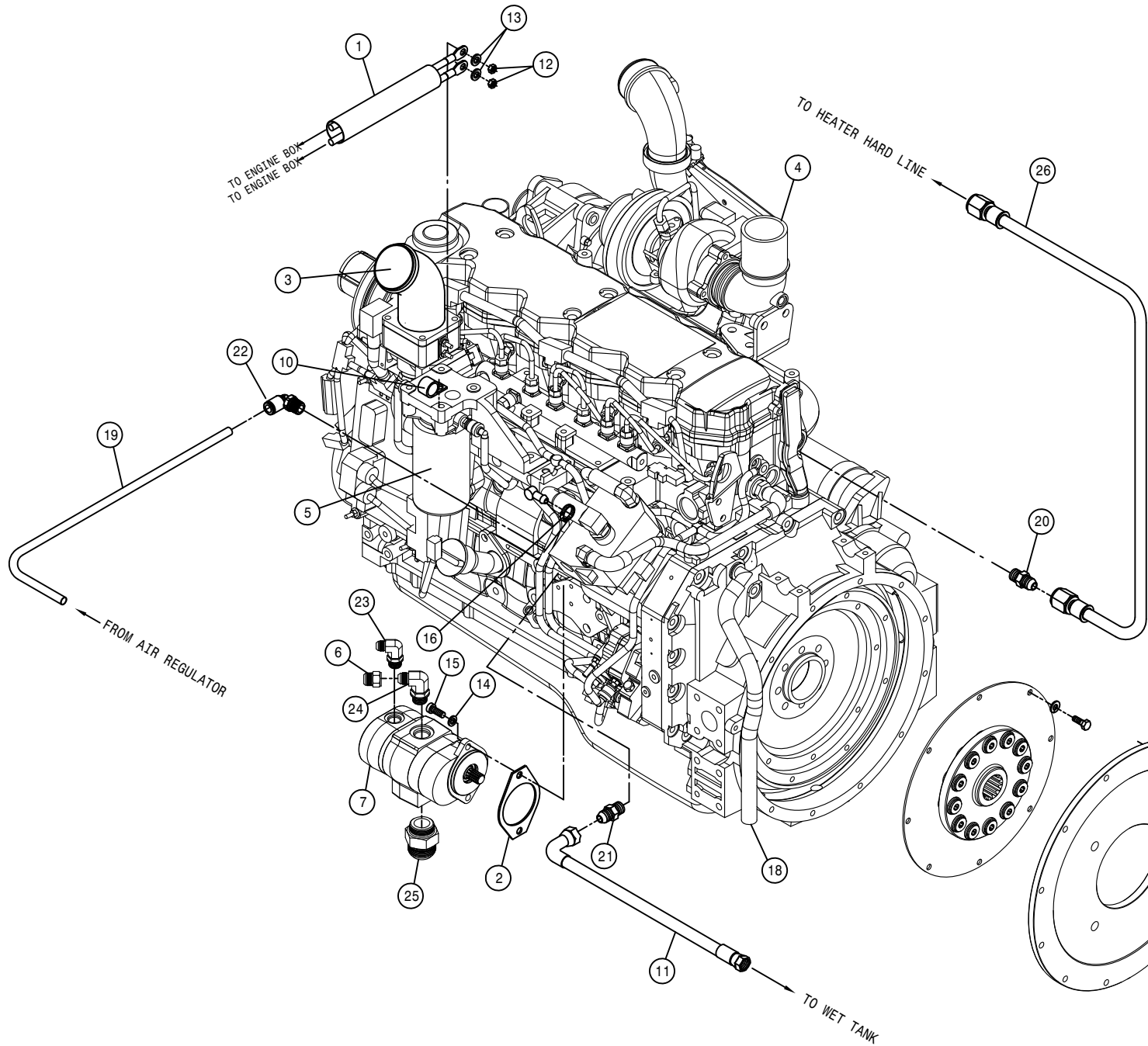

ENGINE ASSEMBLY

DET.	QTY	PART NO.	DESCRIPTION
1	1	292544	ENG HEATR CBL ASSY,RED 6GA '10
2	1	316371	GASKET, AUX DRIVE CUMM 154916
3	1	316662	AIR INTAKE PIPE W/FLG,T3 ENG
4	1	316923	CUMM ENG, 275HP HI TORQ STS'12
5	1	316683	FUEL FILTER, ENG, TIER 3 07
6	1	618641	1 1/16FJIC-1 5/16MJIC ADPTR
7	1	606450	TANDEM PUMP,606451 & 606452
8	12	473798	10MM LOCK WASHER
9	12	473818	10MM-1.50 X 40MM HEX BOLT (H)
10	1	520121	CUSH CLAMP,#16 1IN X 3/4W
11	1	611306	12-P919J-12FJX-12FJX90-42 H/A
12	2	473767	6MM-1.00 HEX NUT
13	2	473768	6MM LOCK WASHER
14	2	473799	10MM FLAT WASHER
15	2	473844	10MM-1.50 X 30 SOC HD CAP SCR
16	1	520120	HOSE CLAMP NO 4 STAINLESS
17	1	520160	CUSH CLAMP,#24 1 1/2D-3/4WLOOP
18	1	601537	HOSE, 3/4 X 24 CLEAR VINYL
19	1	601625	HOSE, 1/4 X 14 AIR
20	1	618059	7/8MJIC-3/4MNPT ADPTR
21	1	618699	1 1/16MJIC-M27X2.0MOR ADPTR
22	1	711039	1/8MNPT-90-1/4 NYL TUBE LBO
23	1	618183	3/4MJIC-90-7/8MOR LBO
24	1	618279	1 1/16MJIC-90-7/8MOR LBO
25	1	618527	1 7/8MJIC-1 5/8MOR ADPTR
26	1	657485	10-213-10FJX-10FJX-62 H/A

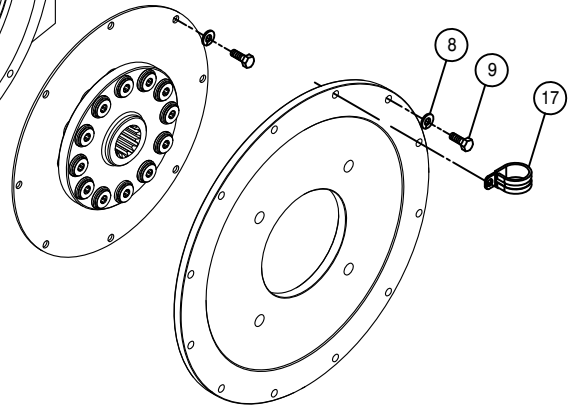

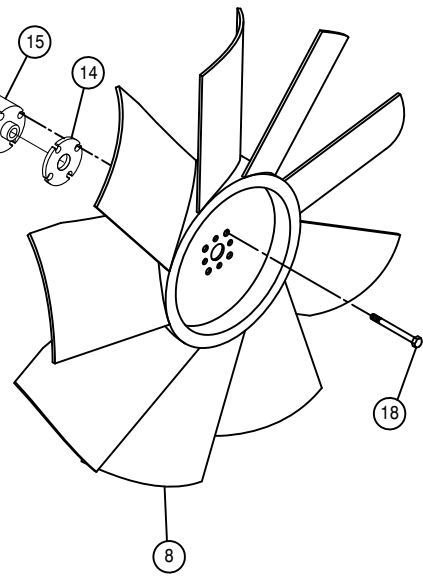
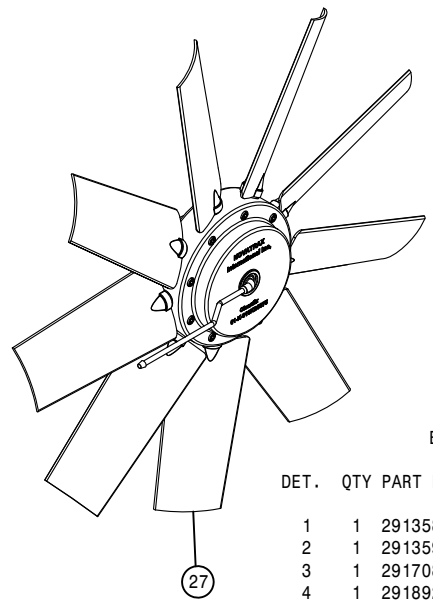
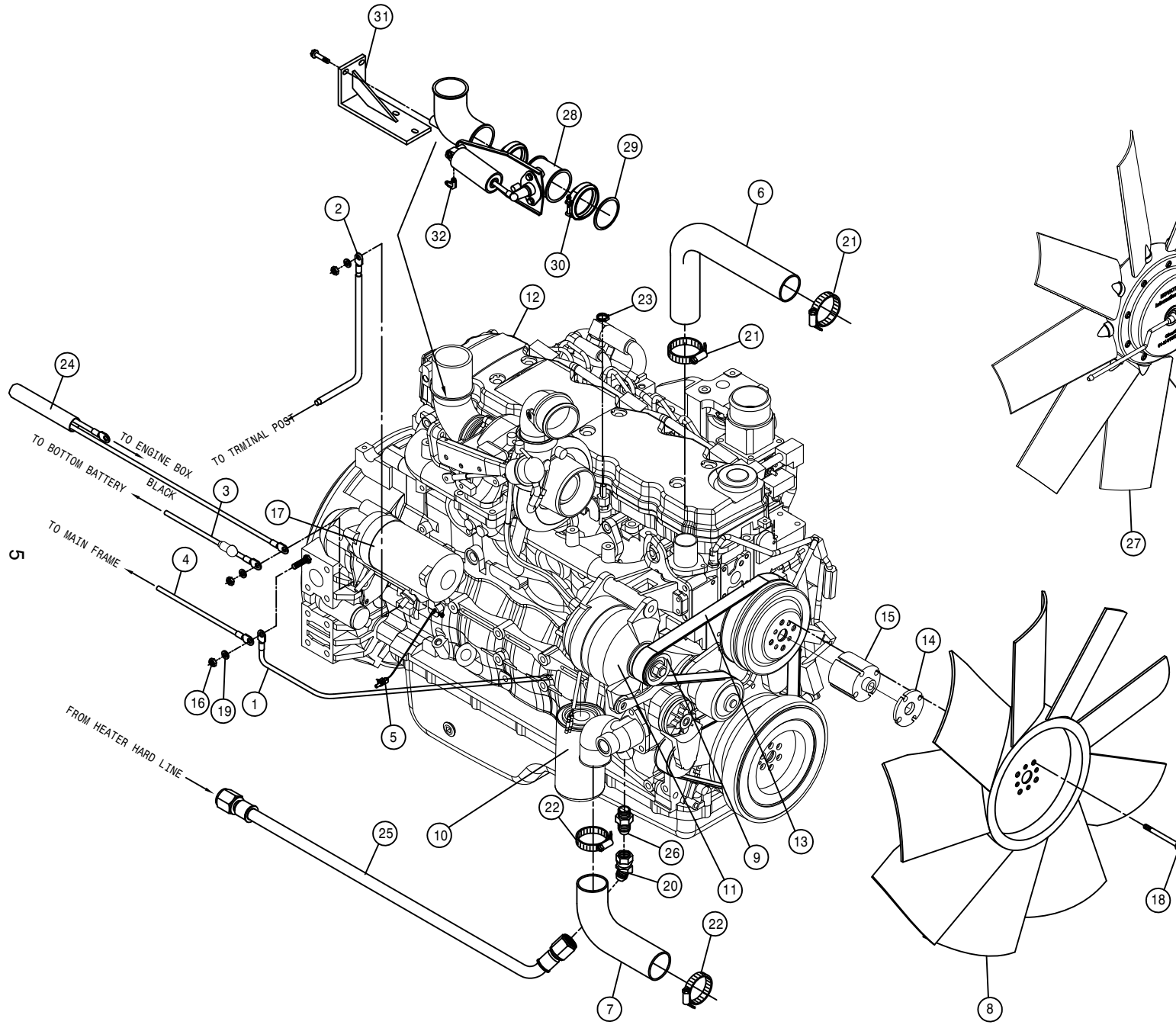

ENGINE ASSEMBLY

DET.	QTY	PART NO.	DESCRIPTION
1	1	291358	BATT CABLE, BLK 56"2GA.281- 8mm
2	1	291359	BATT CABLE, RED 26"2/0 3/8-3/8
3	1	291708	BATT CABLE, BLK 73"2/0 3/8-3/8
4	1	291892	BATT CABLE, BLK 42"4GA.406-.406
5	1	293631	STARTER WIRE HARNESS, STS
6	1	314832	RADIATOR HOSE 1.75 X 19(52818)
7	1	314987	LWR RADIATOR HOSE STS-12
8	1	316524	FAN, 28" CUMM QSB5.9C, STS 02
9	1	316370	ALT PULLEY, 2.76 OD, 8-GROOVE
10	1	316372	LUBE FILTER (CUMM ENG 316360)
11	1	316391	DELCO ALTERNATOR, 130 AMP 24SI
12	1	316923	CUMM ENG, 275HP HI TORQ STS'12
13	1	316680	FAN BELT, TIER 3 ENGINE 07
14	1	316681	FAN SPACER, 6.4MM, TIER 3 ENG 07
15	1	316682	FAN SPACER, 63.5MM, TIER3 ENG 07
16	1	473778	8MM-1.25 HEX NUT
17	1	316686	STARTER, CUMM R2.7 ST9383
18	4	473780	10MM-1.50 X 90MM FLANGE BOLT
19	1	473804	8MM LOCK WASHER
20	1	618628	7/8MJIC-45-7/8FJIC SWIV LBO
21	2	520067	HOSE CLAMP NO 28 STAINLESS
22	2	520099	HOSE CLAMP NO 40 STAINLESS
23	1	520069	HOSE CLAMP NO 6 STAINLESS
24	1	292542	CAB PWR, GND CBLE ASSY STS10/12
25	1	657484	10-213-10FJX-10FJX-89 H/A
26	1	618325	7/8MJIC-1/2MNPT ADPTR
27	1	316810	REVERSING FAN KIT, STS 6.7L 07-
28	1	316644	EXHAUST BRAKE, CUMMINS 05
29	1	316645	GASKET, EXHAUST BRAKE CUMMINS
30	1	316646	V-CLAMP, EXHAUST BRAKE, CUMMINS
31	1	316801	E-BRAKE MT WLD, T3 ENG GST20 06
32	1	711058	7/16MJIC-90-1/4MNPT LBO BRS

A/C COMPRESSOR PUMP ASSEMBLY

DET. QTY PART NO. DESCRIPTION

DET.	QTY	PART NO.	DESCRIPTION
1	1	147052	BELT, 9470 GATES
2	1	316591	A/C MTG BRKT WLD, STS 2004
3	3	473844	10MM-1.50 X 30 SOC HD CAP SCR
4	3	473798	10MM LOCK WASHER
5	1	291675	PED, TERM, M, WP, 16-14GA
6	1	657450	A/C COMP SR, 90D PORT TM15/12
7	4	900131	3/8UNC X 1 1/2 HEX BOLT
8	4	910004N	3/8UNC FLANGE CNTR LOCK NUT
9	1	657446	A/C HOSE, 08-08F90-08F90SV-65"
10	1	657447	A/C HOSE, 10-10F90-10F90SV-92"
11	1	291593	PED, RECP, WP, 1W
12	1	291620	PED, SEAL, GREEN, 18-16GA

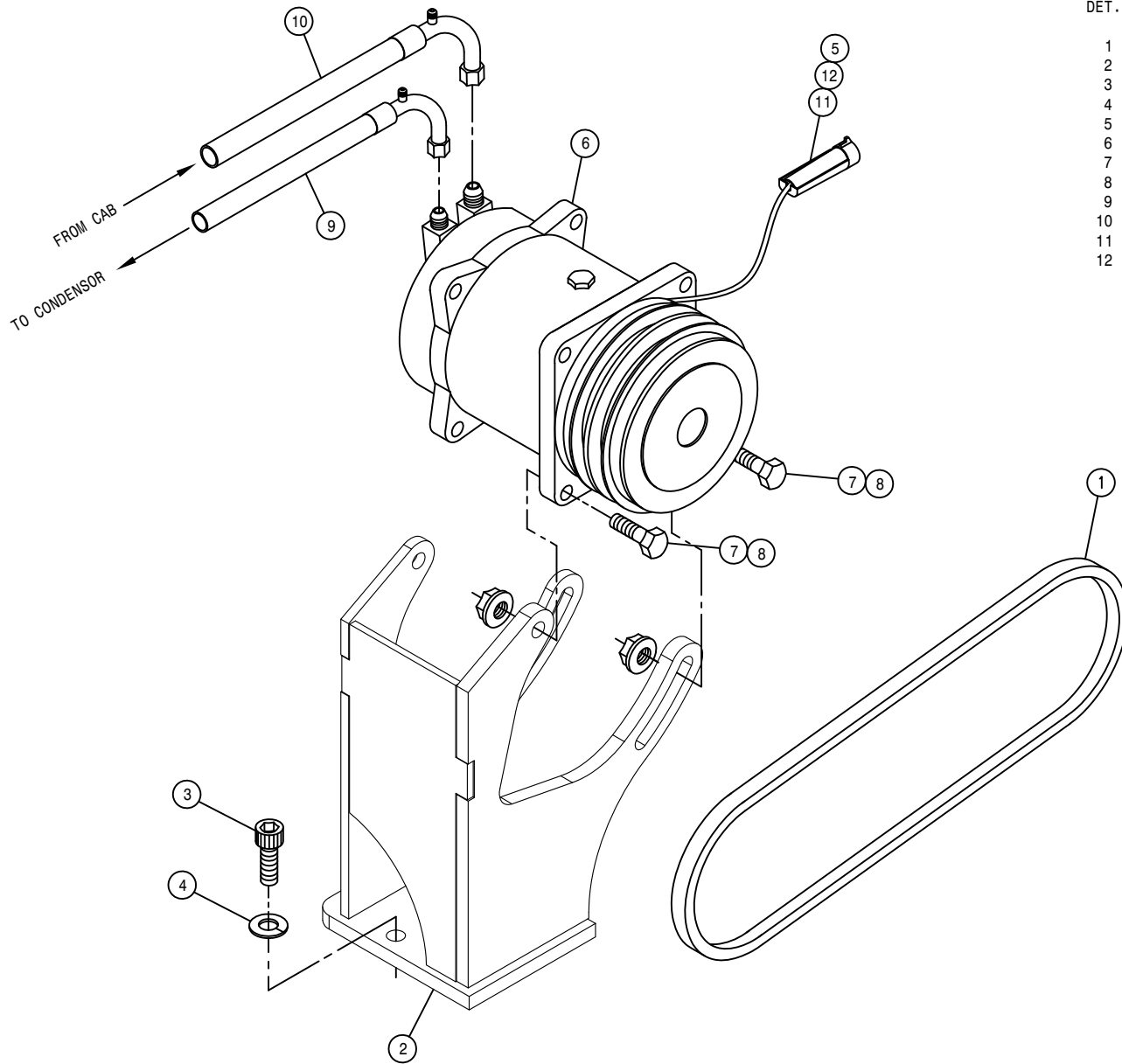

HYDROSTATIC PUMP ASSEMBLY

DET.	QTY	PART NO.	DESCRIPTION
1	4	472367	3/4UNC X 2" SM FLANGE BOLT GR8
2	4	473839	20MM FLAT WASHER
3	4	473854	20MM LOCK WASHER
4	2	473855	12MM-1.75 X 35MM FLANGE BOLT
5	16	473857	12MM-1.75 X 45MM FLANGE BOLT
6	4	473860	20MM-2.50 X 50MM HEX BOLT
7	1	606258	REFIEF, LS PUMP SAUER
8	1	606357	O-RING,3.737ID-.103CS-3.94 BMT
9	4	606196	PRESS TRANSDUCER ASSY 9000PSI
10	1	606512	H1-P-115CC PUMP,D/D-MT SAUER
11	1	606513	H1-P-115CC PUMP,D/B-MT SAUER
12	1	607004	SAUER PISTON PUMP JRR060B
13	1	607026	O-RING,5.905ID- 6.1410D DMT
14	1	611126	7/8MJIC-7/8MOR ADPTR
15	1	616038	04-471TC-06FJX-06FJX90-15 H/A
16	2	618126	9/16MJIC-9/16MOR ADPTR
17	1	618130	7/8MOR RUN TEE-7/8MJIC
18	1	618183	3/4MJIC-90-7/8MOR LBO
19	3	618186	1 5/16MJIC-1 5/16MOR ADPTR
20	1	618333	7/8FJIC SW RUN TEE-7/8MJIC
21	1	618363	7/16FJIC CAP NUT
22	1	618394	O-RING FOR 2" FLANGE -32
23	1	618451	3/4FJIC SW RUN TEE-3/4MJIC
24	4	618465	O-RING FOR 1 1/4" FLANGE, -20
25	1	618472	1 5/8MJIC-1 5/8MOR ADPTR
26	1	618509	7/16MOR RUN TEE-7/16MJIC
27	1	618486	9/16FJIC SW RUN TEE-9/16MJIC
28	1	618724	1 5/8MJIC-1 5/8MOR LG ADPTR
29	1	618753	7/16MOR PLUG, HEX SOCKET
30	1	618765	2" FLANGE-2 1/2MJIC ADPTR #61
31	1	618766	2" SPLIT FLANGE KIT #61
32	2	618779	1 11/16FOR-90-1 1/4FLG C62LBO
33	8	618780	1 1/4 SPLIT FLANGE HALF, #62
34	2	618782	9/16MOR-9/16FOR-9/16MJIC BRNCH
35	2	618897	1 1/4"FLANGE-1 11/16FOR ADPTR
36	1	618735	9/16JIC .062 ORIFICE ADPTR
37	4	900138	3/8UNC X 3 1/2 HEX BOLT
38	4	920002	3/8 SAE FLAT WASHER
39	4	920502	3/8 LOCK WASHER
40	2	618531	9/16FJIC CAP NUT

NOTE: 1. (*) USED WITH THE TREAD ADJUST OPTION.
 2. (**) USED WITH THE PRESSURE WASHER OPTION.

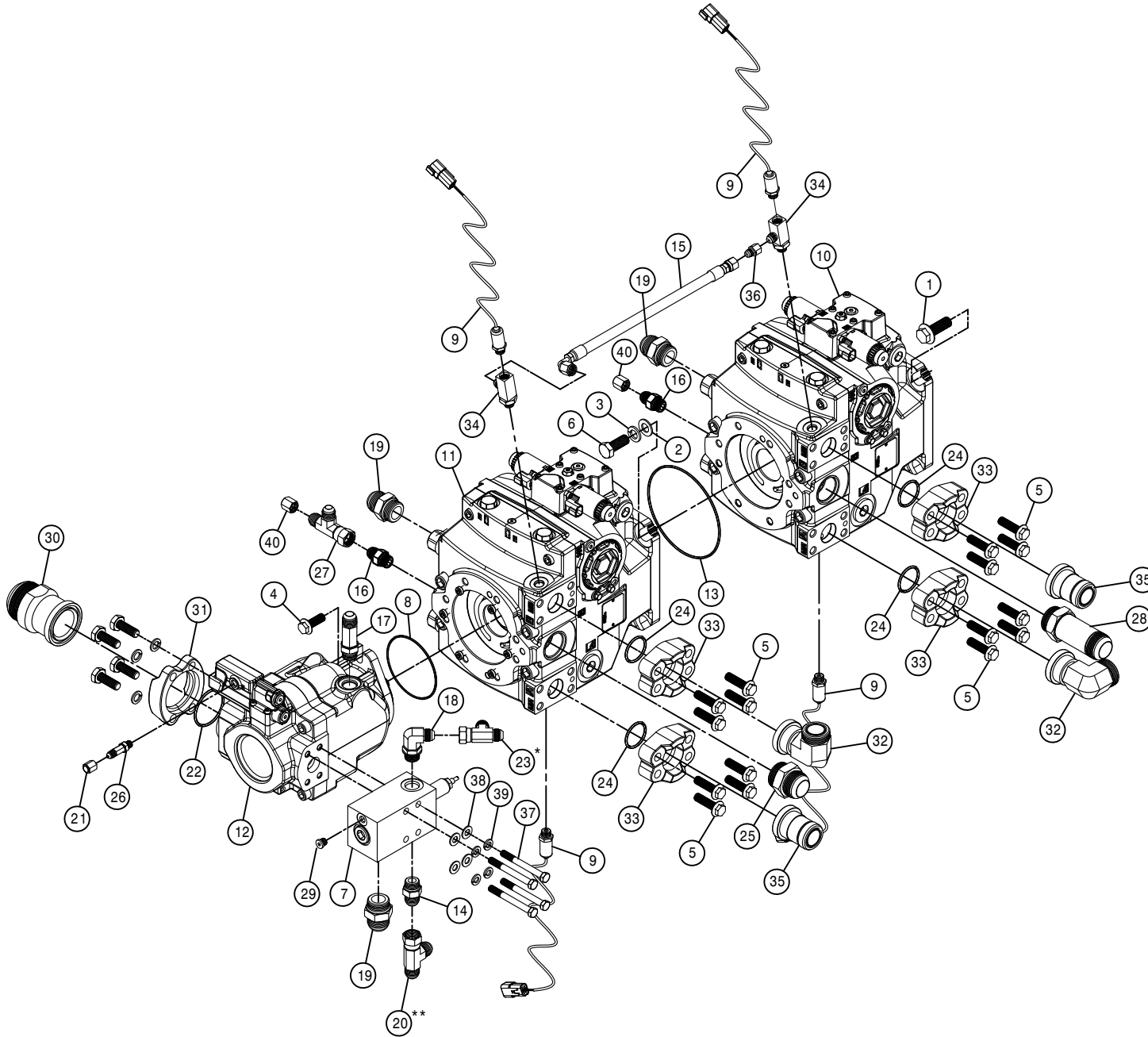

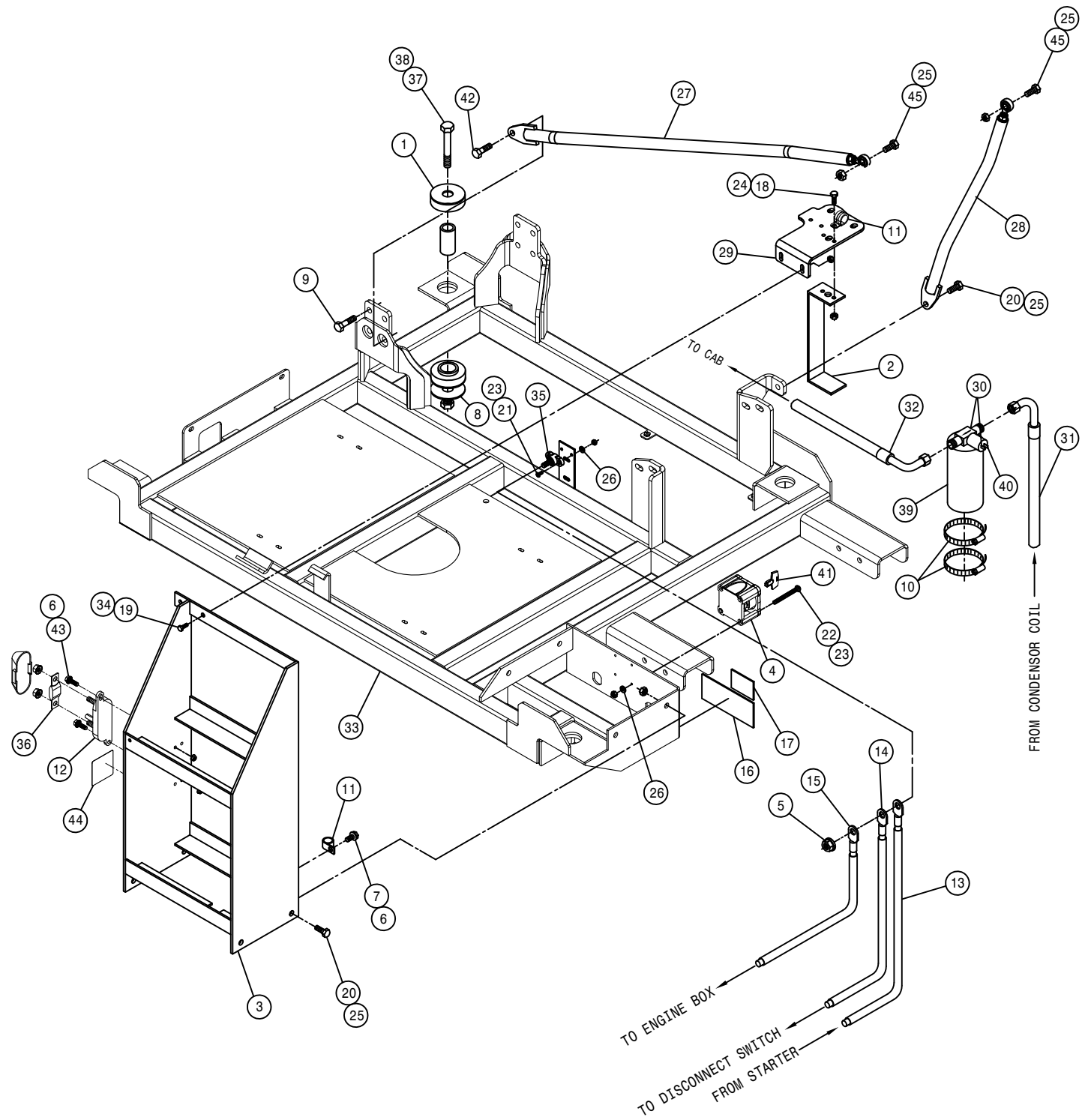

ENGINE SKID ASSEMBLY

DET.	QTY	PART NO.	DESCRIPTION
1	4	311057	RUBBER MT SET,SSB33-1000-4
2	1	316432	A/C DRIER MT
3	1	316637	BATTERY BOX WLD STS 05
4	1	291962	BATTERY SWITCH,ON/OFF(KEY)6005
5	1	910004N	3/8UNC FLANGE CNTR LOCK NUT
6	3	470121	1/4UNC HEX FLANGE LOCK NUT
7	1	470122	1/4UNC X 1/2 FLANGE HEX BOLT
8	4	311091	SNUBBING WASHER FOR 311090
9	11	473855	12MM-1.75 X 35MM FLANGE BOLT
10	2	520052	HOSE CLAMP NO 52 STAINLESS
11	2	520121	CUSH CLAMP,#16 1IN X 3/4W
12	1	292578	HIGH AMP FUSE HOLDER W/COVER
13	1	291359	BATT CABLE,RED 26"2/0 3/8-3/8
14	1	291997	BATT CABLE,RED 40"2/0 3/8-3/8
15	1	292541	BATT CABLE,RED 72"2/0 3/8-1/2
16	1	650107	DECAL,CAUTION BOOSTER STS12
17	1	650372	DECAL,MAIN ELECTRIC DISCONNECT
18	2	900065	5/16UNC X 1" HEX BOLT
19	2	900129	3/8UNC X 1" SERR FLANGE BOLT
20	5	900264	1/2UNC X 1 1/4 HEX BOLT
21	2	903706	10-32X1/2 PHIL PAN MACH SCR
22	4	903897	10-32X2 1/2 PHIL PAN MACH SCR
23	6	910027	10-32 HEX NUT
24	2	914002	5/16UNC HEX STOVER NUT
25	7	914008	1/2UNC HEX STOVER NUT
26	6	920510	#10 LOCK WASHER
27	1	316828	LH RAD BRACE ASSY,STS 10/12"10
28	1	316730	RH RAD BRACE ASSY,STS 10/12"07
29	1	316729	RAD MT PLT, STS T3 QSB 07
30	1	657438	RECEIVER DRIER W/SWITCH
31	1	657443	A/C HOSE,06-06F90-06F90-34"
32	1	657474	A/C HOSE,06-06F-06F90-128"
33	1	316912	ENG SKID WLD,STS10/12 POLY '12
34	2	470087	3/8UNC HEX FLANGE LOCK NUT
35	1	291936	TERM BLOCK,RED, 3/8-16 SINGLE
36	1	291330	FUSE, 200 AMP 32 VOLT DC
37	4	900408	3/4UNC X 3 1/2 HEX BOLT
38	4	914012	3/4UNC HEX STOVER NUT
39	1	657421	A/C RECEIVER/DRIER
40	1	657422	A/C BINARY SWITCH
41	1	291963	KEY,BATTERY SWITCH 291962
42	1	473859	12MM-1.75 X 50MM FLANGE BOLT
43	2	470118	1/4UNC X 3/4 FLANGE HEX BOLT
44	1	650272	DECAL ,200AMP ECM FUSE,STS '11
45	2	900267	1/2UNC X 2" HEX BOLT

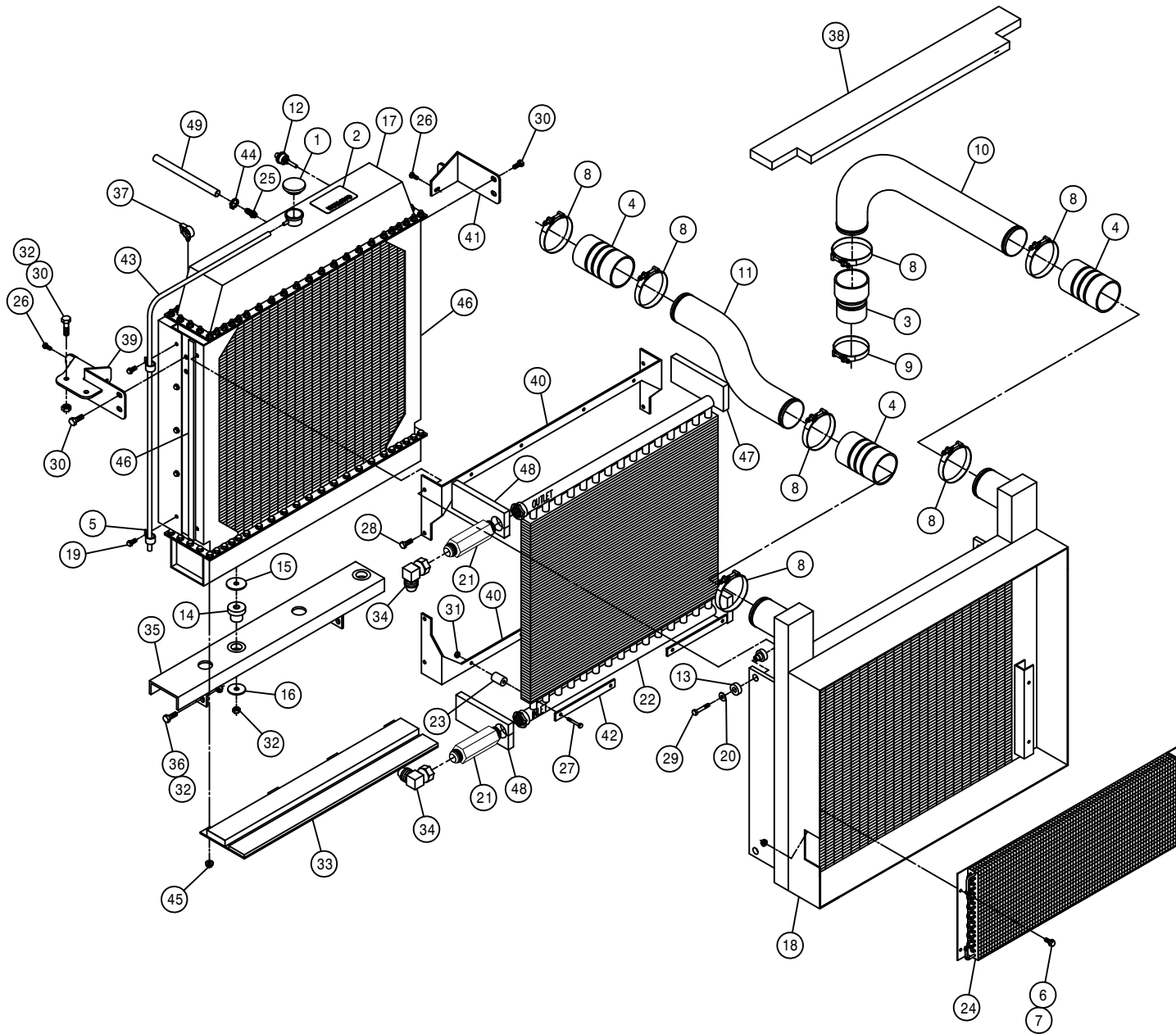

RADIATOR AND OIL COOLER ASSEMBLY

DET.	QTY	PART NO.	DESCRIPTION
1	1	316377	RAD CAP, 10LB 10237
2	1	650174	DECAL,CAUTION RADIATOR,STS 07
3	1	311500	3.50-3.00 X 6.40 REDU CAC HOSE
4	3	311501	3.50 X 6.00 CAC HOSE
5	2	520128	CUSH J CLAMP,#9 9/16D X 3/4W
6	4	470121	1/4UNC HEX FLANGE LOCK NUT
7	4	470122	1/4UNC X 1/2 FLANGE HEX BOLT
8	7	520145	3.56/3.88 T-BOLT HOSE CLAMP SS
9	1	520146	3.06/3.38 T-BOLT HOSE CLAMP SS
10	1	311540	PIPE,CAC TO ENG, STS T3 07
11	1	311539	PIPE,TURBO TO CAC, STS T3 07
12	1	291935	RAD WATER LEVEL SENSOR,T3 ENG
13	4	311056	RUBBER MOUNT SET,2-PC CB 2320
14	2	311060	RUBBER MOUNT,1-PC CB-1122-2
15	2	311061	HEAD WASHER FOR 311060
16	2	311062	TAIL WASHER FOR 311060
17	1	316364	RADIATOR, STS12 2000
18	1	316660	CHARGE AIR COOLER,STS TIER3 O6
19	10	470319	3/8UNC X 1/2 SERR FLANGE BOLT
20	4	483043	3/8 REGULAR FLAT WASHER
21	2	618830	1 5/16MJ-1 5/16MOR 6.0LG ADPTR
22	1	618800	OIL COOLER STS12 2000
23	8	618801	MOUNTING KIT FOR 618800 COOLER
24	1	657434	A/C CONDENSER COIL 21-0302
25	1	783304	1/4 NPT X 3/8 HOSE BARB, BRS
26	2	470233	5/16UNC X 3/4 FLANGE HEX BOLT
27	8	900071	5/16UNC X 2 3/4 HEX BOLT
28	4	900128	3/8UNC X 3/4 HEX BOLT
29	4	900133	3/8UNC X 2" SERR FLANGE BOLT
30	10	900264	1/2UNC X 1 1/4 HEX BOLT
31	8	473001	5/16UNC HEX NUT,NYLOC 316 SS
32	8	914008	1/2UNC HEX STOVER NUT
33	1	316490	LWR RADIATOR FILLER PANEL ASSY
34	2	618640	1 5/16MJ-90-1 5/16FJ SWIV LBO
35	1	316594	RADIATOR MT CHAN WLD, STS 04
36	1	601668	HOSE, 3/8 X 30 HEATER
37	4	291008	ROSEBUD CLIP FOR .350 CONDUIT
38	1	316588	FOAM, STS 04
39	1	316727	UPPER LH RAD MT WLD,STS T3 07
40	2	316452	RAD TO OIL COOLER MT
41	1	316446	UPPER RH RAD MT WLD 2000
42	4	316453	RAD TO OIL COOLER KEEPER
43	1	601614	HOSE, 5/16 X 64 EPDM
44	1	520069	HOSE CLAMP NO 6 STAINLESS
45	4	470113	5/16UNC HEX FLANGE LOCK NUT
46	2	316493	SIDE FOAM,RAD/CAC
47	2	316494	RH UPR/LWR FOAM,OIL CLR/RAD 00
48	2	316495	LH UPR/LWR FOAM,OIL CLR/RAD 00

TO AIR BRAKE (REF)

AIR CLEANER ASSEMBLY

DET. QTY PART NO. DESCRIPTION

DET.	QTY	PART NO.	DESCRIPTION
1	2	193037	STICKERTITE 1/8 X 3/4
2	1	311538	PIPE,AIR CLEANER-TURBO,STS 07
3	1	311507	4.00" 45DEG ELBOW, RUBBER
4	1	311535	5.00-4.00 ID REDUCER BUSHING
5	1	311536	7"-5" REDU HUMP HOSE, RUBBER
6	1	311537	AIR CLEANER HOOD EXT,14"STS 07
7	1	311541	AIR CLEANER,OPTIAIR 1300
8	2	311542	AIR CLEANER MT BAND FOR 311541
9	1	311543	PRIMARY AIR FILTER FOR 311541
10	1	311544	SECONDARY FILTER FOR 311541
11	1	311545	7.00-6.00 REDUCER,STEEL W/CLMP
12	1	316277	AIR COMPRESSOR GOVERNOR KIT
13	1	470480	6" EASYSEAL CLAMP, SS
14	1	316684	FILTER,PRE FUEL 25 MICRON
15	2	520134	4.31/4.59 T-BOLT HOSE CLAMP SS
16	1	520148	5.38/5.69 T-BOLT HOSE CLAMP SS
17	1	520149	7.13/7.44 T-BOLT HOSE CLAMP SS
18	3	520150	7.38/7.69 T-BOLT HOSE CLAMP SS
19	1	520163	CUSH CLAMP,#8 1/2D X 3/4W
20	7	470087	3/8UNC HEX FLANGE LOCK NUT
21	4	470121	1/4UNC HEX FLANGE LOCK NUT
22	5	470460	3/8UNC X 1 SERR FLANGE BOLT
23	1	473782	12MM-1.75 X 18MM HEX BOLT
24	1	473784	12MM LOCK WASHER
25	2	473855	12MM-1.75 X 35MM FLANGE BOLT
26	1	520102	CUSH CLAMP,#20 1 1/4D X 1/2W
27	1	520101	CUSH CLAMP,#16 1"D X 1/2W
28	1	601707	HOSE, 1/4 X 63 AIR
29	1	311565	COVER ASSEMBLY FOR 311541
30	2	711036	1/8MNPT-1/4 NYL TUBE FTG
31	1	711039	1/8MNPT-90-1/4 NYL TUBE LBO
32	2	900072	5/16UNC X 3" HEX BOLT
33	2	502707	PIPE NIPPLE,1/4NPT HEX, BRS
34	2	901255	1/2UNC X 1 1/2 CARR BOLT
35	2	914002	5/16UNC HEX STOVER NUT
36	2	914008	1/2UNC HEX STOVER NUT
37	1	316796	AIR CLEANER MT WLD, STS T3 07
38	1	316716	RH FRT HOOD BRACE, STS T3 07
39	2	903855	8-32 X 1 1/2 PHIL PAN HD SCR
40	1	520069	HOSE CLAMP NO 6 STAINLESS
41	1	601625	HOSE, 1/4 X 14 AIR
42	1	601554	HOSE, 1/4 X 46 AIR
43	4	470118	1/4UNC X 3/4 FLANGE HEX BOLT
44	1	311520	ENGINE PRE CLEANER
45	1	711061	1/4NPT PLUG, SKT HEX HEAD BRS
46	1	293568	PRESS SWITCH HARNESS,STS16 05
47	1	311082	AIR VALVE ASSY,STS16-GST20 05
48	1	311083	PRESSURE SWITCH,80PSI,12VDC
49	1	316656	E-BRAKE CTRL VLV MT,STLS16 06
50	2	470402	1/4MNPT MUFFLER
51	2	470463	8-32 SERR. FLANGE NUT
52	1	611352	04-213-04FJX-04FJX-25 H/A
53	1	601671	HOSE, 1/4 X 145 AIR
54	1	711049	1/4 NYL TUBE-1/4MNPT FTG
55	1	711057	7/16MJIC-1/4MNPT ADPTR BRS
56	1	711060	1/4 UNION TEE BRS
57	1	311567	AIR CLEANER EXTEN,6"OD X 18"LG
58	1	311566	7"ID-6"ID REDU SLEEVE, RUBBER
59	1	316931	AIR INTAKE SUPP,QSB TIER 3
60	2	900129	3/8UNC X 1" SERR FLANGE BOLT
61	4	920000	1/4 SAE FLAT WASHER

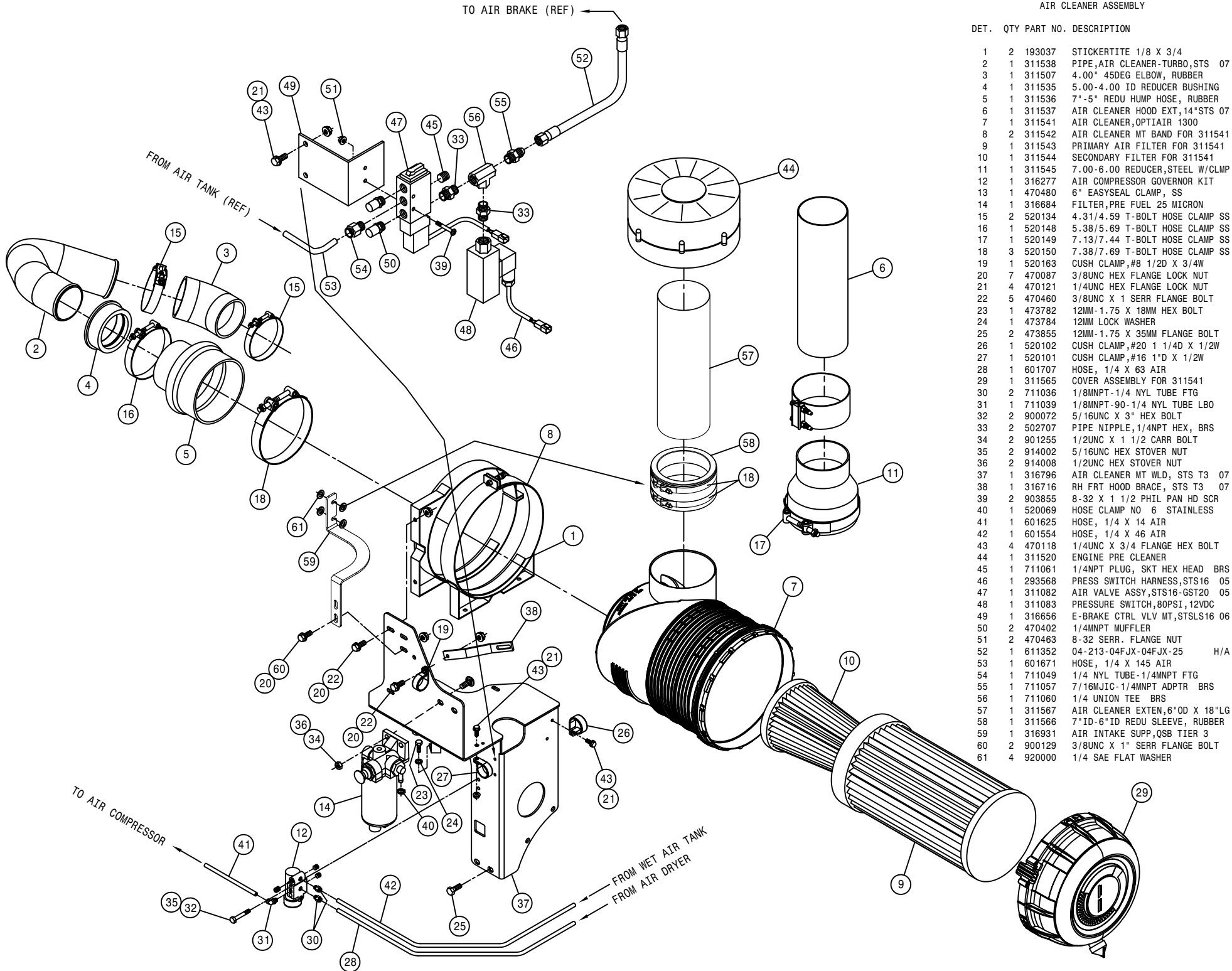

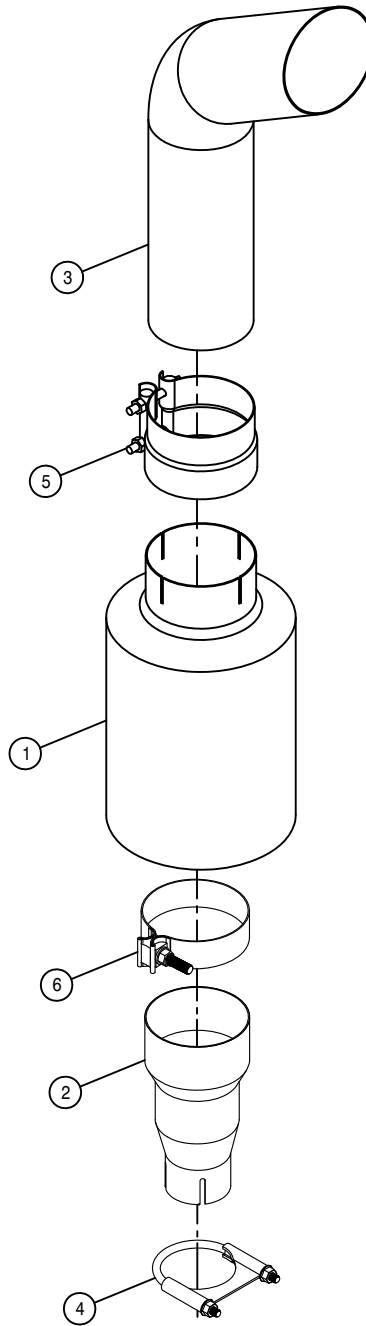
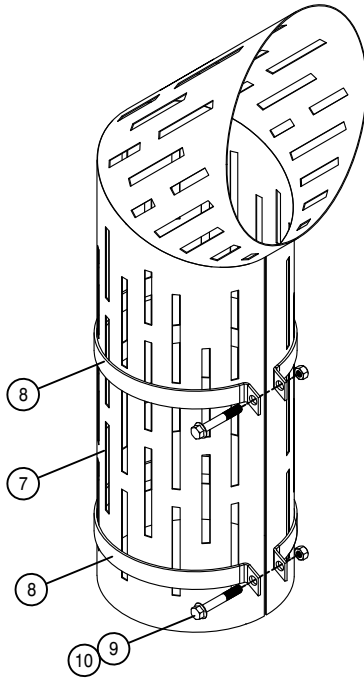

MUFFLER ASSEMBLY

DET. QTY PART NO. DESCRIPTION

1	1	316657	MUFFLER 5"
2	1	316816	EXH REDUCER CONNECTOR
3	1	316817	EXHAUST STACK, ANGLED
4	1	470475	3" EXHAUST CLAMP
5	1	470477	5" LAP EXHAUST CLAMP
6	1	470600	MUFFLER CLAMP, 5.00 ACCUSEAL
7	1	343794	MUFFLER GUARD WLD, STS '11
8	2	343796	MUFFLER GUARD CLMP BAND, STS '11
9	2	900134	3/8UNC X 2 1/2 SER FLANGE BOLT
10	2	914004	3/8UNC HEX STOVER NUT

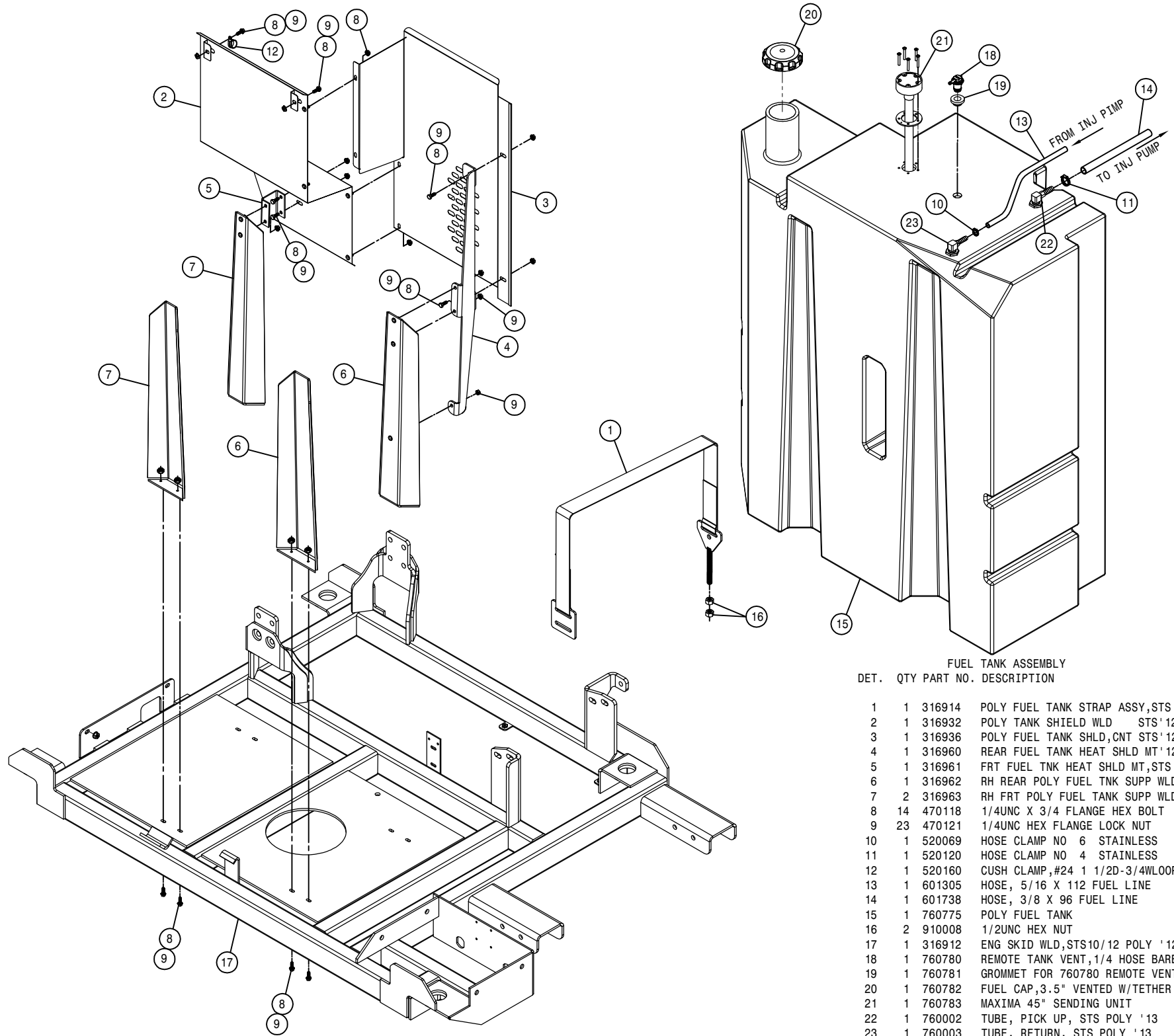

FUEL TANK ASSEMBLY
DET. QTY PART NO. DESCRIPTION

DET.	QTY	PART NO.	DESCRIPTION
1	1	316914	POLY FUEL TANK STRAP ASSY,STS
2	1	316932	POLY TANK SHIELD WLD STS'12
3	1	316936	POLY FUEL TANK SHLD,CNT STS'12
4	1	316960	REAR FUEL TANK HEAT SHLD MT'12
5	1	316961	FRT FUEL TNK HEAT SHLD MT,STS
6	1	316962	RH REAR POLY FUEL TNK SUPP WLD
7	2	316963	RH FRT POLY FUEL TANK SUPP WLD
8	14	470118	1/4UNC X 3/4 FLANGE HEX BOLT
9	23	470121	1/4UNC HEX FLANGE LOCK NUT
10	1	520069	HOSE CLAMP NO 6 STAINLESS
11	1	520120	HOSE CLAMP NO 4 STAINLESS
12	1	520160	CUSH CLAMP,#24 1 1/2D-3/4WLOOP
13	1	601305	HOSE, 5/16 X 112 FUEL LINE
14	1	601738	HOSE, 3/8 X 96 FUEL LINE
15	1	760775	POLY FUEL TANK
16	2	910008	1/2UNC HEX NUT
17	1	316912	ENG SKID WLD,STS10/12 POLY '12
18	1	760780	REMOTE TANK VENT,1/4 HOSE BARB
19	1	760781	GROMMET FOR 760780 REMOTE VENT
20	1	760782	FUEL CAP,3.5" VENTED W/TETHER
21	1	760783	MAXIMA 45" SENDING UNIT
22	1	760002	TUBE, PICK UP, STS POLY '13
23	1	760003	TUBE, RETURN, STS POLY '13

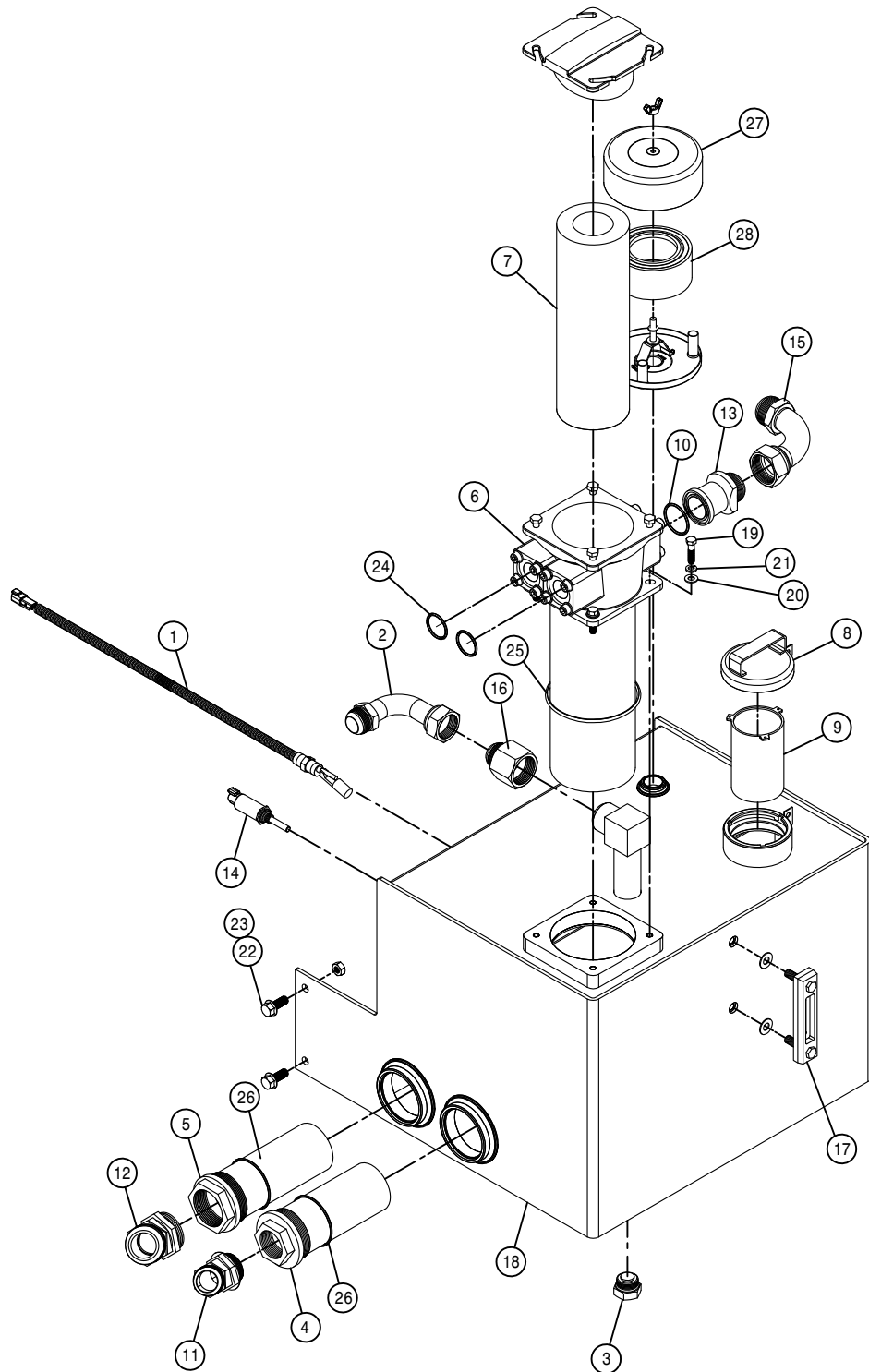

HYDRAULIC TANK ASSEMBLY

DET. QTY PART NO. DESCRIPTION

1	1	293815	LIQUID LEV SWITCH ASSY,1/2NPO5
2	1	618768	1 5/8MJIC-90-1 5/8FJX TUBE
3	1	470471	1 5/16MOR PLUG, MAGNETIC
4	1	605622	SUCTION STRAINER,21GPM 100M 24
5	1	605623	SUCTION STRAINER,39GPM 100M 32
6	1	605625	IN-TANK RETURN FILTER, 10M
7	1	605626	FILTER ELEMENT FOR 605625 10M
8	1	605646	FILL CAP-HYD RSRVR NON-VENTED
9	1	605645	STRAINER-HYD RSRVR
10	1	618395	O-RING FOR 1 1/2" FLANGE -24
11	1	618745	1 7/8MJIC-45-1 7/8MOR LBO
12	1	618746	2 1/2MJIC-45-2 1/2MOR LBO
13	1	618747	1 1/2 FLANGE-1 7/8MJIC ADPTR
14	1	291995	TEMPERATURE TRANSDUCER,HYDAC
15	1	618764	1 7/8MJIC-90-1 7/8FJX TUBE LBO
16	1	618767	1 7/8FJIC-1 5/8MJIC ADPTR
17	1	760177	SIGHT GAUGE W/TEMP, HYD TANK
18	1	760732	HYD TANK WLD,STS10/12/14 '10
19	4	900131	3/8UNC X 1 1/2 HEX BOLT
20	4	920002	3/8 SAE FLAT WASHER
21	4	920502	3/8 LOCK WASHER
22	4	900264	1/2UNC X 1 1/4 HEX BOLT
23	4	914008	1/2UNC HEX STOVER NUT
24	2	618465	O-RING FOR 1 1/4" FLANGE, -20
25	1	605632	O-RING,-357,FILTER HEAD 605625
26	2	605638	O-RING,-48 3.228ID-.118W
27	1	605647	BREATHER-HYD RSRVR
28	1	605648	FOAM BREATHER, HYD RSRVR

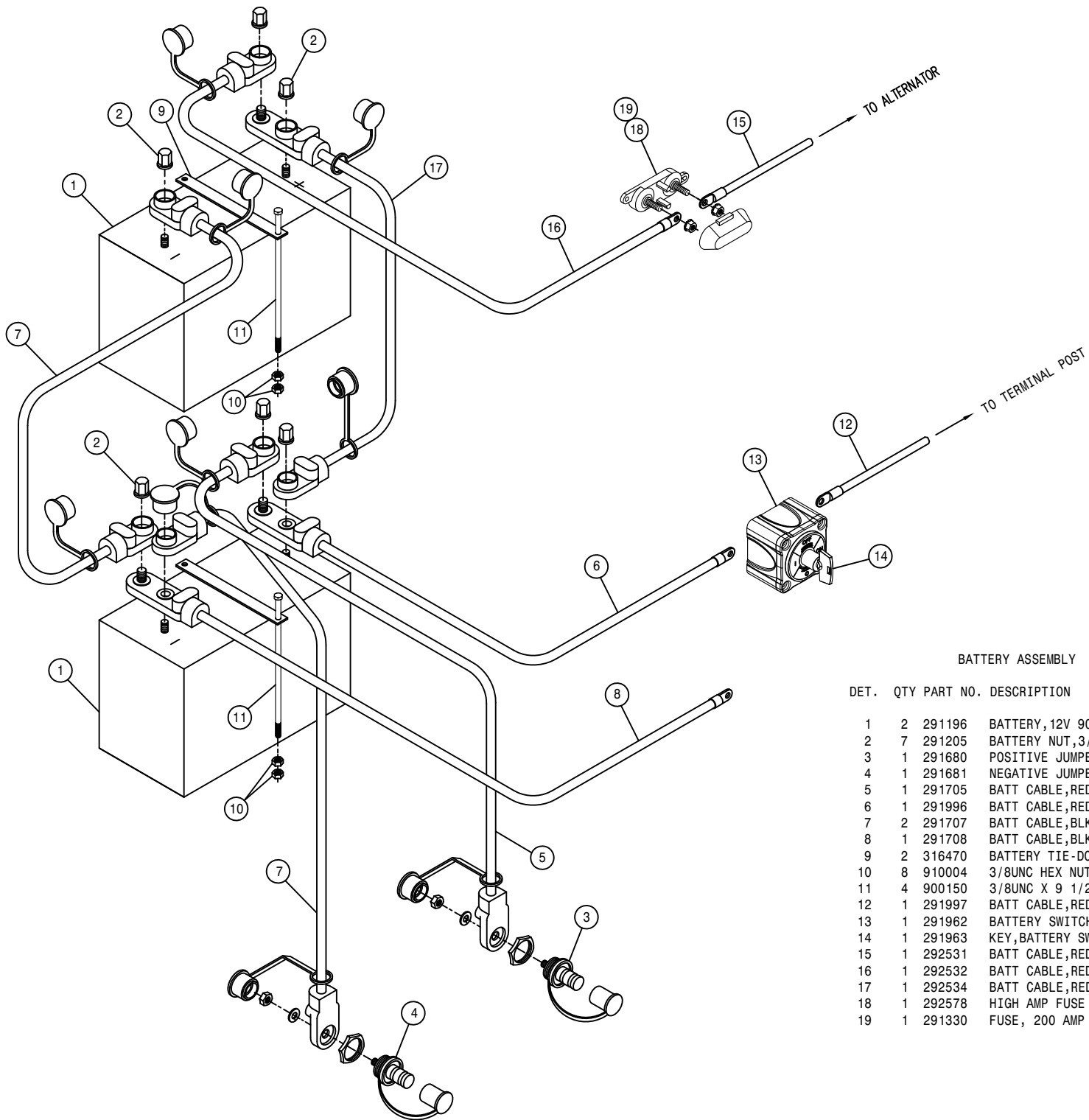

BATTERY ASSEMBLY

DET.	QTY	PART NO.	DESCRIPTION
1	2	291196	BATTERY, 12V 900 CCA, SS STUD
2	7	291205	BATTERY NUT, 3/8-16 SS CLSD CAP
3	1	291680	POSITIVE JUMPER STUD, RED
4	1	291681	NEGATIVE JUMPER STUD, BLACK
5	1	291705	BATT CABLE, RED 26"2/0 3/8-3/8
6	1	291996	BATT CABLE, RED 34"2/0 3/8-3/8
7	2	291707	BATT CABLE, BLK 26"2/0 3/8-3/8
8	1	291708	BATT CABLE, BLK 73"2/0 3/8-3/8
9	2	316470	BATTERY TIE-DOWN
10	8	910004	3/8UNC HEX NUT
11	4	900150	3/8UNC X 9 1/2 HEX BOLT
12	1	291997	BATT CABLE, RED 40"2/0 3/8-3/8
13	1	291962	BATTERY SWITCH, ON/OFF (KEY) 6005
14	1	291963	KEY, BATTERY SWITCH 291962
15	1	292531	BATT CABLE, RED 41"1/0.312-.343
16	1	292532	BATT CABLE, RED 25"1/0.312-.375
17	1	292534	BATT CABLE, RED 26"2/0.375-.375
18	1	292578	HIGH AMP FUSE HOLDER W/COVER
19	1	291330	FUSE, 200 AMP 32 VOLT DC

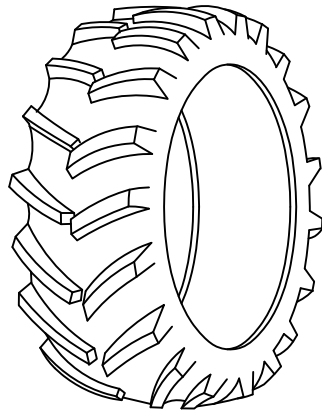
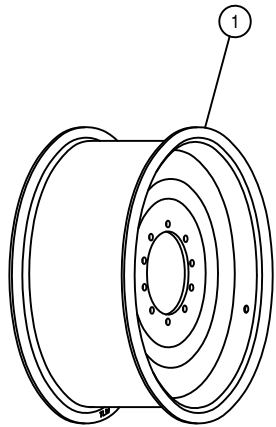

580/70 R38 RADIAL TIRE

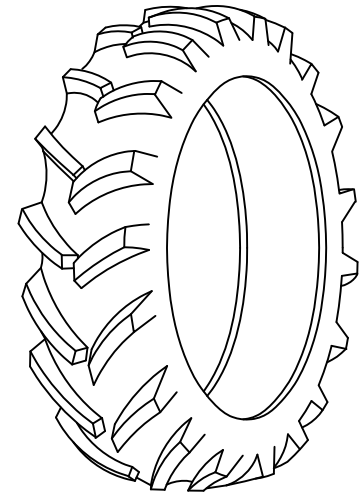
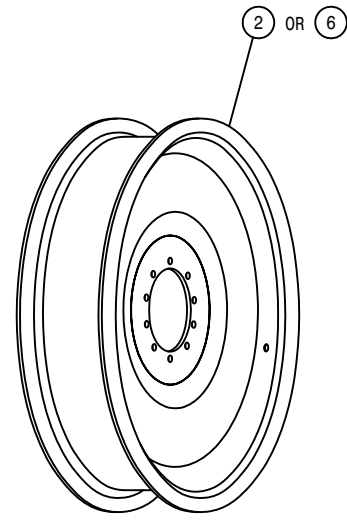

380/90 R46 RADIAL TIRE

520/85 R46 RADIAL TIRE

TIRE AND RIM ASSEMBLY

DET. QTY PART NO. DESCRIPTION

1	1	821055	RIM WLD, 38 X W18A	STS12
2	1	821054	RIM WLD, 46 X W13A	STS12
3	1	821053	RIM WLD, 50 X DW10	STS
4	1	821058	RIM WLD, 54 X W10A	
5	1	821059	RIM WLD, 54 X W12	
6	1	821061	RIM WLD, 46 X W16	

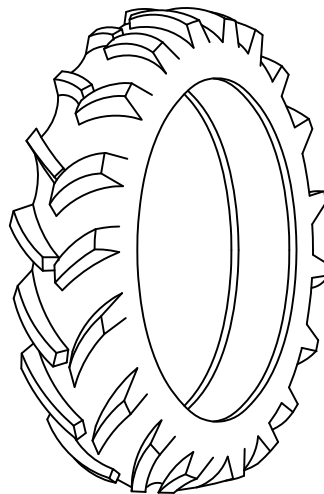
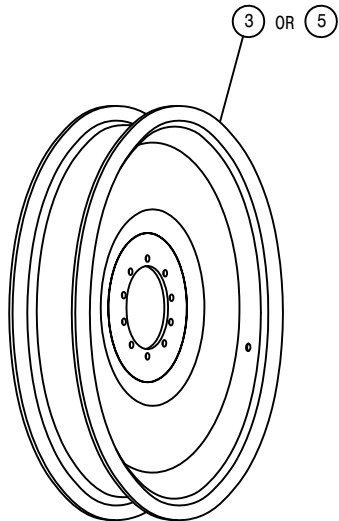

320/90 R50 RADIAL TIRE

380/90 R54 RADIAL TIRE

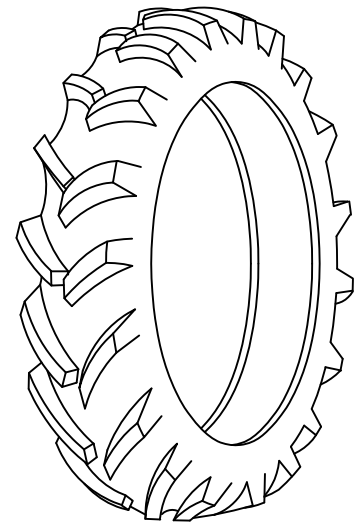
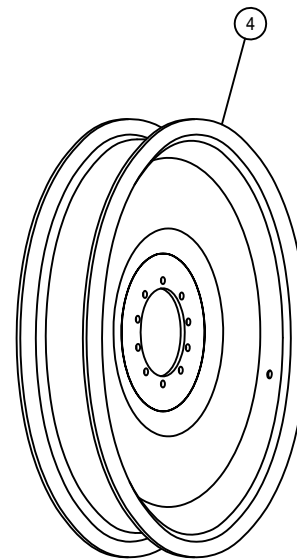

320/105 R54 RADIAL TIRE

RIGHT FRONT OUTER LEG ASSEMBLY

DET.	QTY	PART NO.	DESCRIPTION
1	2	121029	JOURNAL BRG, 1.00 ID X 1.00 LG
2	4	121113	BEARING, 1.50-1.81-1.86 POLYGON
3	2	121120	LEG SLEEVE BRG,AWS POLYGON
4	1	125050	BRG CONE, 1.00 ID W/FACE SEAL
5	1	125051	BRG CUP FOR 125050
6	1	125052	BRG CONE, 2.687 ID W/FACE SEAL
7	1	125053	BRG CUP FOR 125052
8	2	311058	RUBBER SPRING
9	1	311080	AIRIDE SPRING, 11.81 BASE
10	1	358832	AIRIDE SPRING CTRL VALVE 98
11	1	359641	HOSE SUPP SWIVEL PLT STS'12
12	1	359333	AIRBAG TOWER TOP MT WLD,STS 05
13	1	359350	RH EXTENDED HOSE SUPPORT, STS
14	1	359369	RH LEG AIR VALVE MT, STS16 05
15	1	359544	LEG HEIGHT CTRL LINK,AWS STS09
16	2	359545	TRUNION MT BOLT, AWS STS 09
17	1	359546	STRG CYL BOLT, AWS STS 09
18	1	359547	TOP TRUNION MT WLD, AWS STS 09
19	1	359548	BTM TRUNION MT WLD, AWS STS 09
20	1	359593	STRG ARM CLAMP WLD,STS '10
21	1	359638	HOSE SUPP SWIVEL WLD STS'12
22	1	359556	RH AIR BAG LWR PLT WLD,AWS STS
23	2	359563	NITRO TOWER WLD, AWS STS 09
24	1	359632	OUTER LEG WLDMT,96D AWS STS'11
25	3	470117	COTTER PIN 3/16 1 3/4 SQ CUT
26	2	470447	KEY, .50 SQ X 1.69 LG
27	5	471005	GREASE ZERK, 1/4-28 X 1/2
28	2	920004	1/2 SAE FLAT WASHER
29	1	472328	1"-12 HEX JAM NUT
30	2	472337	5/8 X 3" SOCKET HD CAP SCR
31	1	473975	ROD END,1.00 BORE,1-12 RH MALE
32	1	920508	1" LOCK WASHER
33	1	520164	CUSH CLAMP,9/16D-3/4W-.531MT
34	1	601473	HOSE, 1/4 X 18 AIR
35	2	618241	3/4MJIC-90-3/4MOR LBO
36	1	621614	HYD CYL,2.50 X 8.81 PHASE/2SEN
37	1	621615	REPAIR KIT,HYD CYL 621614
38	8	629537	187RRHOZ SNAP RING
39	2	629538	4.5 SPIROLOX RING
40	4	629620	SEAL, 1.500 ROD DIA
41	2	629621	SEAL, 4.500 ROD DIA
42	2	711036	1/8MNPT-1/4 NYL TUBE FTG
43	1	711040	1/4MNPT-90-1/4 NYL TUBE LBO
44	2	900002	1/4UNC X 3/4 HEX BOLT
45	5	900265	1/2UNC X 1 1/2 HEX BOLT
46	4	900267	1/2UNC X 2" HEX BOLT
47	4	900268	1/2UNC X 2 1/2 HEX BOLT
48	4	900269	1/2UNC X 2 3/4 HEX BOLT
49	1	910008	1/2UNC HEX NUT
50	1	910013	3/4UNF HEX NUT
51	1	910020	1-8 HEX SLOTTED NUT
52	1	910021	1-14 SLOT JAM NUT
53	2	914000	1/4UNC HEX STOVER NUT
54	13	914008	1/2UNC HEX STOVER NUT
55	2	910102	3/4UNC SLOT HEX NUT, GR8
56	1	920008	1" SAE FLAT WASHER
57	1	920504	1/2 LOCK WASHER
58	1	920506	3/4 LOCK WASHER
59	2	473841	16MM LOCK WASHER
60	1	601480	HOSE, 1/4 X 230 AIR
61	1	470310	SIDEWINDER SLEEVE,14.06 X 45"
62	1	470305	HOSE CLAMP, 4-HOLE
63	1	359094	HYD TUBE CLAMP KEEPER, 5.75
64	3	342917	TREAD ADJ PLATE, STEEL, THD
65	4	342719	TRD ADJ BRONZE BEARING,THD-GRV
66	16	900128	3/8UNC X 3/4 HEX BOLT
67	2	900138	3/8UNC X 3 1/2 HEX BOLT
68	2	914004	3/8UNC HEX STOVER NUT
69	4	483048	3/4 REG FLAT WASH,THRU-HARD
70	1	002815	SENSOR ARM WASH, NYL
71	2	359645	STRG CYL SENSOR GUARD STS'12
72	4	903726	1/4UNC X3/8PHIL PANHD MACH SCR
73	4	920000	1/4 SAE FLAT WASHER
74	4	920500	1/4 LOCK WASHER
75	2	121112	BEARING,4.51-4.85-5.74 POLYGON

NOTE: (*) FOR TREAD ADJUST OPTION REPLACE ITEM 64 WITH THREE OF ITEM 65.

(***) ITEMS ARE A MID YEAR BEARING CHANGE.

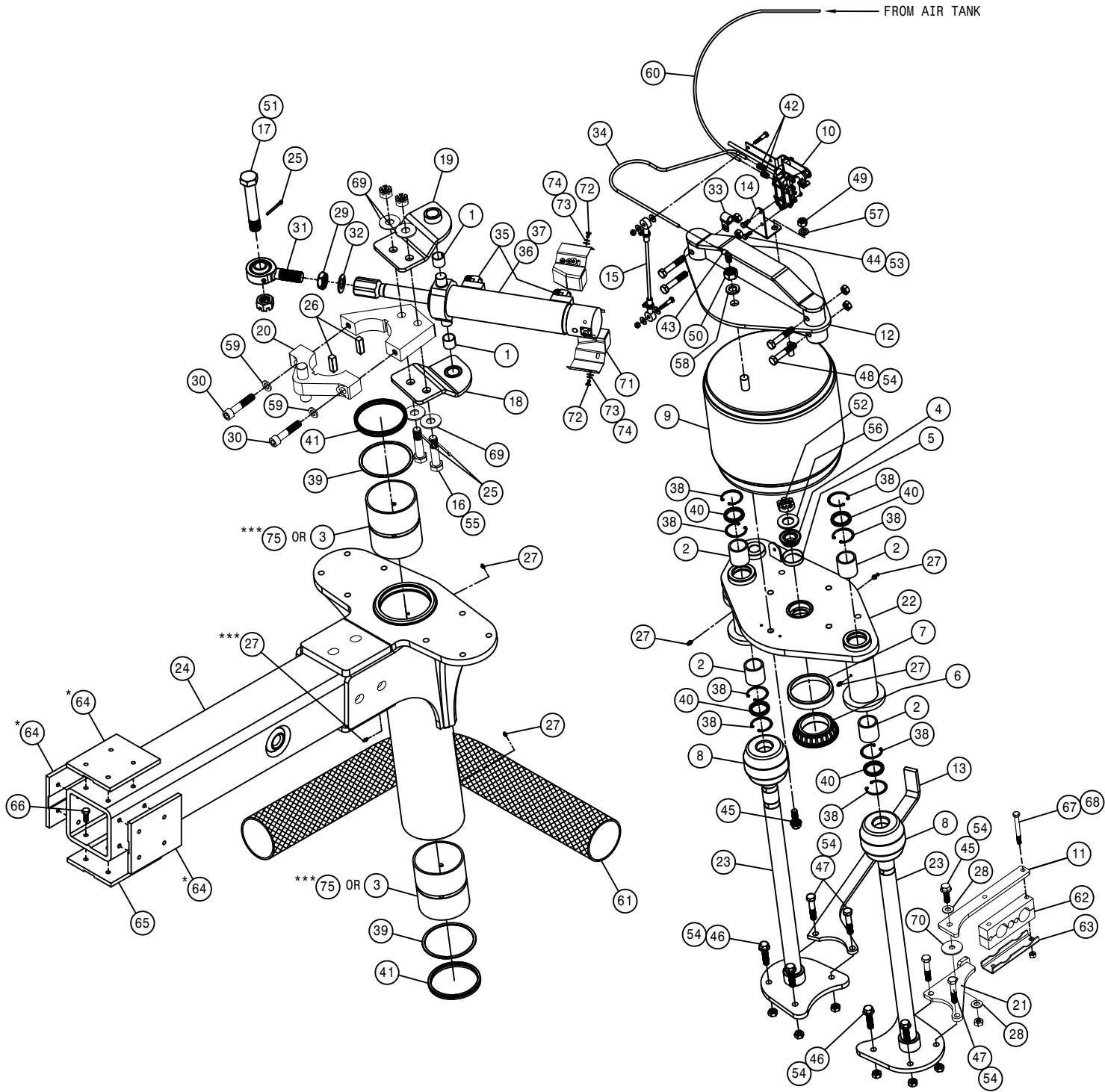

RH FRONT INNER LEG ASSEMBLY (STANDARD TORQUE)

DET. QTY PART NO. DESCRIPTION

1	1	359565	INNER LEG WLD, AWS STS	09
2	1	470117	COTTER PIN 3/16 1 3/4 SQ CUT	
3	1	470305	HOSE CLAMP, 4-HOLE	
4	1	359990	RH WHL MTR SHLD, 10/12/14HT '12	
5	1	359642	RH LEG HOSE SUPP EXTEN STS '12	
6	18	473840	16MM-2.00 X 40MM SOCKT CAP SCR	
7	20	473841	16MM LOCK WASHER	
8	1	606288	WHL MOTOR, 51C060 SAUER	
9	1	610962	WHEEL HUB, 23:1 BONFIG	
10	2	618431	3/4 (-12) SPLIT FLANGE KIT #62	
11	2	870214	BUNA ORING 1 X 1 1/4, 90D	
12	10	824055	22MM-1.50 FLANGED WHEEL NUT	
13	2	900138	3/8UNC X 3 1/2 HEX BOLT	
14	3	473987	1/2UNC X 1 1/4 BUT SKTHD SCR SS	
15	2	900265	1/2UNC X 1 1/2 HEX BOLT	
16	4	914004	3/8UNC HEX STOVER NUT	
17	6	914008	1/2UNC HEX STOVER NUT	
18	1	618812	3/4 FLANGE-1 7/16MFOR ADPTR	
19	2	359644	WHEEL MTR SHEILD BRACE STS '12	
20	1	359624	RH LWR FENDER MT WLD, STS '10	
21	1	359094	HYD TUBE CLAMP KEEPER, 5.75	
22	1	470379	SIDEWINDER SLEEVE, 14.06 X 57"	
23	1	618740	3/4 FLANGE-90-1 7/16MFOR LBO	
24	1	618469	3/4MJIC-1 1/16MOR ADPTR	
25	1	470378	SIDEWINDER SLEEVE, 14.06 X 21"	
26	1	615875	WHEEL MOTOR HYD TUBE ASSY	
27	4	900266	1/2UNC X 1 3/4 HEX BOLT	
28	2	359367	BUSHING, CROP SHIELD, STS 05	
29	3	473988	1/2UNC HEX NUT, NYLOC SS	
30	1	618677	O-RING, -16 FACE SEAL .93ID 90D	
31	1	293848	WHL MTR JMPR HARNESS, STS16 05	
32	1	606321	SOLENOID, WHL MTR 606288/291	
33	2	473861	16MM-2.00 X 40MM HEX BOLT	
34	1	607026	O-RING, 5.905ID- 6.141OD DMT	
35	1	606322	LIP SEAL, WHL MTR 606288/291	
36	1	606323	O-RING, WHL MTR 606288/291	
37	10	610887	STUD, M22 X 1,5 X 78	
38	2	900130	3/8UNC X 1 1/4 SER FLANGE BOLT	
39	1	606386	WHL MOTOR, 51C060 SAUER W/DEUTS	

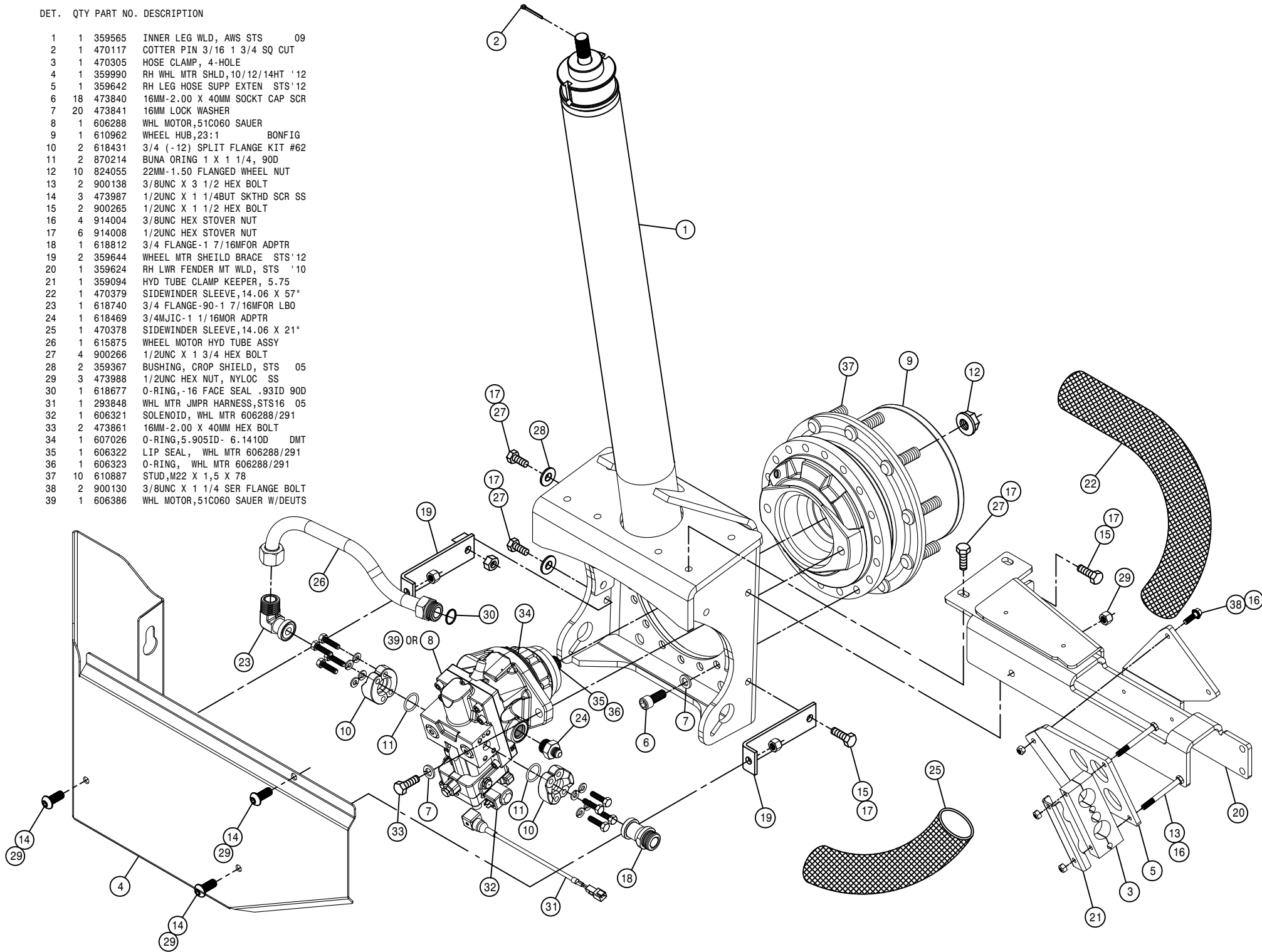

RH FRONT INNER LEG ASSEMBLY (HI TORQUE)

DET. QTY PART NO. DESCRIPTION

1	1	359565	INNER LEG WLD, AWS STS	09
2	1	470117	COTTER PIN 3/16 1 3/4 SQ CUT	
3	1	470305	HOSE CLAMP, 4-HOLE	
4	1	359990	RH WHL MTR SHLD, 10/12/14HT '12	
5	1	359642	RH LEG HOSE SUPP EXTEN STS'12	
6	17	473840	16MM-2.00 X 40MM SOCKT CAP SCR	
7	17	473841	16MM LOCK WASHER	
8	1	606514	H1-B-80CC WHL MTR SAUER	
9	1	610506	TORQ HUB, 25:1 CW18E	
10	2	618652	1" SPLIT FLANGE KIT	
11	2	473838	20MM-1.50 X 40MM HEX BOLT 8.8	
12	10	824055	22MM-1.50 FLANGED WHEEL NUT	
13	2	900138	3/8UNC X 3 1/2 HEX BOLT	
14	3	473987	1/2UNC X 1 1/4BUT SKTHD SCR SS	
15	2	900265	1/2UNC X 1 1/2 HEX BOLT	
16	4	914004	3/8UNC HEX STOVER NUT	
17	6	914008	1/2UNC HEX STOVER NUT	
18	1	618473	7/16MJIC-90-7/16MOR LBO	
19	2	359644	WHEEL MTR SHEILD BRACE STS'12	
20	1	359624	RH LWR FENDER MT WLD, STS '10	
21	1	359094	HYD TUBE CLAMP KEEPER, 5.75	
22	1	470379	SIDEWINDER SLEEVE, 14.06 X 57"	
23	2	618654	1" FLANGE-90-1 7/16MFOR LBO	
24	1	618602	3/4MJIC-45-7/8MOR LBO	
25	1	470378	SIDEWINDER SLEEVE, 14.06 X 21"	
26	1	615909	WHL MTR TUBE ASSY STS'12	
27	4	900266	1/2UNC X 1 3/4 HEX BOLT	
28	2	359367	BUSHING, CROP SHIELD, STS 05	
29	3	473988	1/2UNC HEX NUT, NYLOC SS	
30	1	618677	O-RING, -16 FACE SEAL .93ID 90D	
31	1	294166	HI TOR SPD SNSR HARNESS STS'12	
32	2	900130	3/8UNC X 1 1/4 SER FLANGE BOLT	
33	1	615908	WHL MTR HYD TUBE ASSY STS'12	
34	1	606190	O-RING, WHL MTR HSNB SAUER	
35	2	473839	20MM FLAT WASHER	

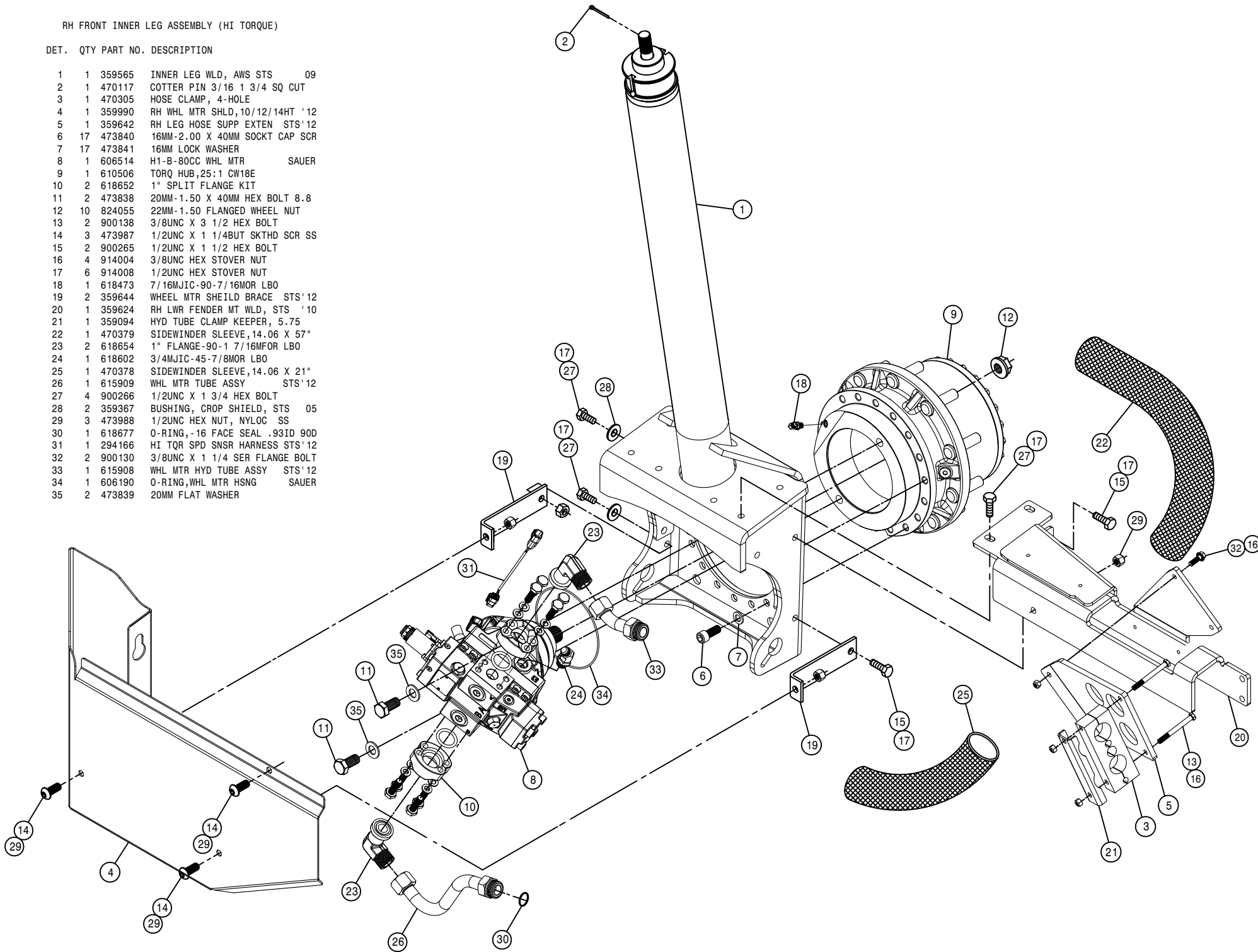

LEFT FRONT OUTER LEG ASSEMBLY

DET.	QTY	PART NO.	DESCRIPTION
1	2	121029	JOURNAL BRG, 1.00 ID X 1.00 LG
2	4	121113	BEARING, 1.50-1.81-1.86 POLYGON
3	2	121120	LEG SLEEVE BRG,AWS POLYGON
4	1	125050	BRG CONE, 1.00 ID W/FACE SEAL
5	1	125051	BRG CUP FOR 125050
6	1	125052	BRG CONE, 2.687 ID W/FACE SEAL
7	1	125053	BRG CUP FOR 125052
8	2	311058	RUBBER SPRING
9	1	311080	AIRIDE SPRING, 11.81 BASE
10	1	358832	AIRIDE SPRING CTRL VALVE 98
11	1	359641	HOSE SUPP SWIVEL PLT STS' 12
12	1	359333	AIRBAG TOWER TOP MT WLD,STS 05
13	1	359351	LH EXTENDED HOSE SUPPORT, STS
14	1	359370	LH LEG AIR VALVE MT, STS16 05
15	1	359544	LEG HEIGHT CTRL LINK,AWS STS09
16	2	359545	TRUNION MT BOLT, AWS STS 09
17	1	359546	STRG CYL BOLT, AWS STS 09
18	1	359547	TOP TRUNION MT WLD, AWS STS 09
19	1	359548	BTM TRUNION MT WLD, AWS STS 09
20	1	359593	STRG ARM CLAMP WLD,STS '10
21	1	621551	REPAIR KIT,HYD CYL,STRG 621550
22	1	359557	LH AIR BAG LWR PLT WLD,AWS STS
23	2	359563	NITRO TOWER WLD, AWS STS 09
24	1	359632	OUTER LEG WLDMT,96D AWS STS' 11
25	3	470117	COTTER PIN 3/16 1 3/4 SQ CUT
26	2	470447	KEY, .50 SQ X 1.69 LG
27	5	471005	GREASE ZERK, 1/4-28 X 1/2
28	2	618249	3/4MJIC-90-9/16MOR LBO
29	1	472328	1"-12 HEX JAM NUT
30	2	472337	5/8 X 3" SOCKET HD CAP SCR
31	1	473975	ROD END, 1.00 BORE, 1-12 RH MALE
32	1	920508	1" LOCK WASHER
33	1	520164	CUSH CLAMP,9/16D-3/4W-.531MT
34	1	601473	HOSE, 1/4 X 18 AIR
35	2	618241	3/4MJIC-90-3/4MOR LBO
36	1	621602	HYD CYL, 2.50 X 8.81 PHASE/1SEN
37	1	621604	REPAIR KIT, HYD CYL 621602/603
38	8	629537	187RRH00Z SNAP RING
39	2	629538	4.5 SPIROLOX RING
40	4	629620	SEAL, 1.500 ROD DIA
41	2	629621	SEAL, 4.500 ROD DIA
42	2	711036	1/8MNPT-1/4 NYL TUBE FTG
43	1	711040	1/4MNPT-90-1/4 NYL TUBE LBO
44	2	900002	1/4UNC X 3/4 HEX BOLT
45	5	900265	1/2UNC X 1 1/2 HEX BOLT
46	4	900267	1/2UNC X 2" HEX BOLT
47	4	900268	1/2UNC X 2 1/2 HEX BOLT
48	4	900269	1/2UNC X 2 3/4 HEX BOLT
49	1	910008	1/2UNC HEX NUT
50	1	910013	3/4UNF HEX NUT
51	1	910020	1-8 HEX SLOTTED NUT
52	1	910021	1-14 SLOT JAM NUT
53	2	914000	1/4UNC HEX STOVER NUT
54	13	914008	1/2UNC HEX STOVER NUT
55	2	910102	3/4UNC SLOT HEX NUT, GR8
56	1	920008	1" SAE FLAT WASHER
57	1	920504	1/2 LOCK WASHER
58	1	920506	3/4 LOCK WASHER
59	2	473841	16MM LOCK WASHER
60	1	601479	HOSE, 1/4 X 196 AIR
61	1	470310	SIDEWINDER SLEEVE, 14.06 X 45"
62	1	470305	HOSE CLAMP, 4-HOLE
63	1	359094	HYD TUBE CLAMP KEEPER, 5.75
64	3	342917	TREAD ADJ PLATE, STEEL, THD
65	4	342719	TRD ADJ BRONZE BEARING, THD-GRV
66	16	900128	3/8UNC X 3/4 HEX BOLT
67	2	900138	3/8UNC X 3 1/2 HEX BOLT
68	2	914004	3/8UNC HEX STOVER NUT
69	4	483048	3/4 REG FLAT WASH, THRU-HARD
70	1	621550	HYD CYL, 2.50 X 8.81 X 1.250
71	1	002815	SENSOR ARM WASH, NYL
72	1	359638	HOSE SUPP SWIVEL WLD STS' 12
73	2	920004	1/2 SAE FLAT WASHER
74	2	121112	BEARING, 4.51-4.85-5.74 POLYGON

NOTE: (*) FOR TREAD ADJUST OPTION REPLACE ITEM 64 WITH THREE OF ITEM 65.

(**) ITEMS ARE FOR ALL WHEEL STEER OPTION.

(***) ITEMS ARE A MID YEAR BEARING CHANGE.

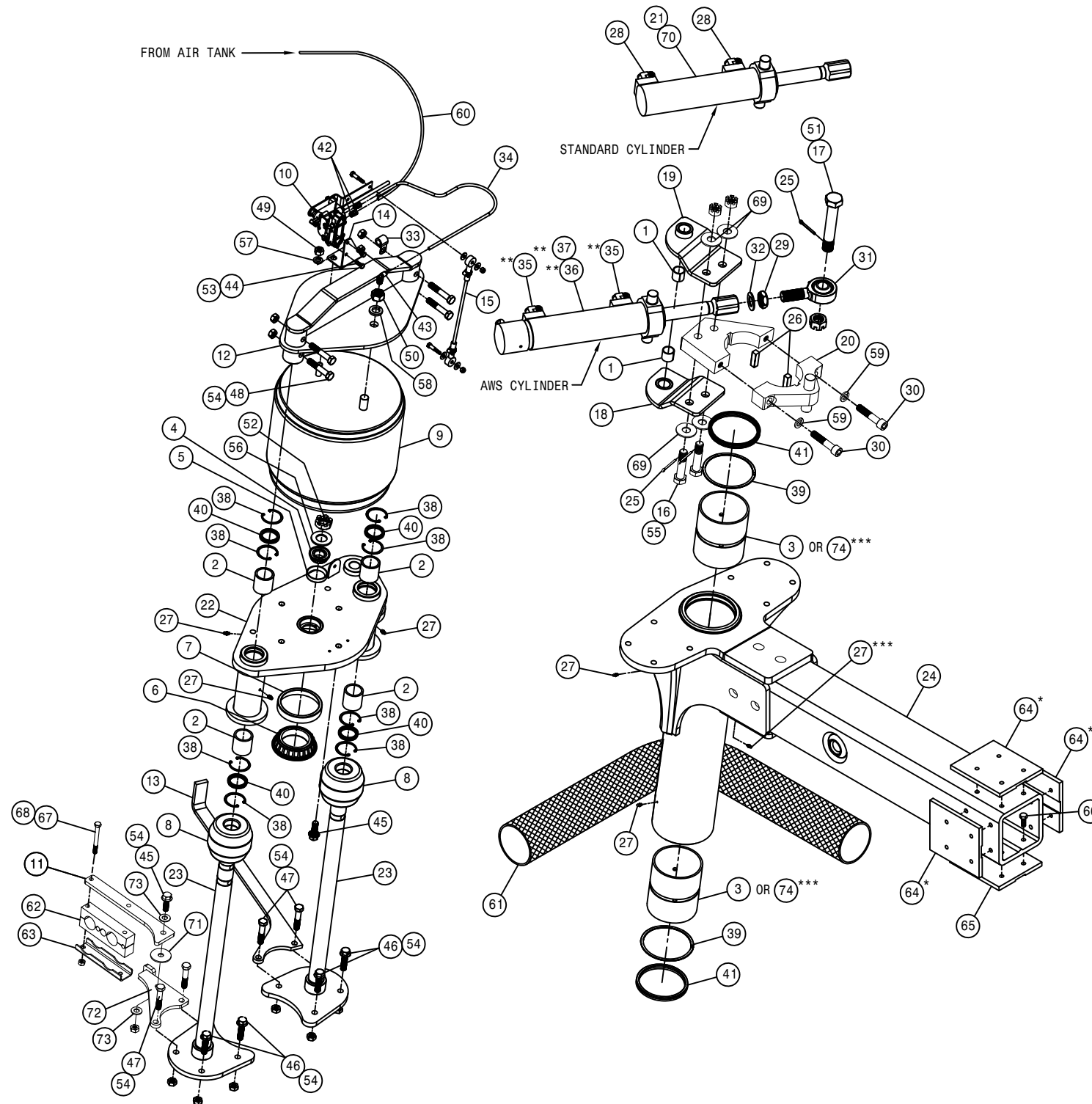

LH FRONT INNER LEG ASSEMBLY (STANDARD TORQUE)

DET. QTY PART NO. DESCRIPTION

DET.	QTY	PART NO.	DESCRIPTION
1	1	359565	INNER LEG WLD, AWS STS 09
2	1	470117	COTTER PIN 3/16 1 3/4 SQ CUT
3	1	470305	HOSE CLAMP, 4-HOLE
4	1	359991	LH WHL MTR SHLD,10/12/14HT '12
5	1	359643	LH LEG HOSE SUPP EXTEN STS'12
6	18	473840	16MM-2.00 X 40MM SOCKET CAP SCR
7	20	473841	16MM LOCK WASHER
8	1	606288	WHL MOTOR,51C060 SAUER
9	1	610962	WHEEL HUB,23:1 BONFIG
10	2	618431	3/4 (-12) SPLIT FLANGE KIT #62
11	2	870214	BUNA ORING 1 X 1 1/4, 90D
12	10	824055	22MM-1.50 FLANGED WHEEL NUT
13	2	900138	3/8UNC X 3 1/2 HEX BOLT
14	3	473987	1/2UNC X 1 1/4BUT SKTHD SCR SS
15	2	900265	1/2UNC X 1 1/2 HEX BOLT
16	4	914004	3/8UNC HEX STOVER NUT
17	6	914008	1/2UNC HEX STOVER NUT
18	1	618812	3/4 FLANGE-1 7/16MFOR ADPTR
19	2	359644	WHEEL MTR SHEILD BRACE STS'12
20	1	359625	LH LWR FENDER MT WLD, STS '10
21	1	359094	HYD TUBE CLAMP KEEPER, 5.75
22	1	470379	SIDEWINDER SLEEVE,14.06 X 57"
23	1	615875	WHEEL MOTOR HYD TUBE ASSY
24	1	618469	3/4MJIC-1 1/16MOR ADPTR
25	4	900266	1/2UNC X 1 3/4 HEX BOLT
26	1	470378	SIDEWINDER SLEEVE,14.06 X 21"
27	1	618740	3/4 FLANGE-90-1 7/16MFOR LBO
28	2	359367	BUSHING, CROP SHIELD, STS 05
29	3	473988	1/2UNC HEX NUT, NYLOC SS
30	1	618677	O-RING, -16 FACE SEAL .93ID 90D
31	1	293848	WHL MTR JMPR HARNESS, STS16 05
32	1	606321	SOLENOID, WHL MTR 606288/291
33	2	473861	16MM-2.00 X 40MM HEX BOLT
34	1	607026	O-RING,5.905ID- 6.1410D DMT
35	1	606322	LIP SEAL, WHL MTR 606288/291
36	1	606323	O-RING, WHL MTR 606288/291
37	10	610887	STUD,M22 X 1,5 X 78
38	2	900130	3/8UNC X 1 1/4 SER FLANGE BOLT
39	1	606386	WHL MOTOR,51C060 SAUER W/DEUTS

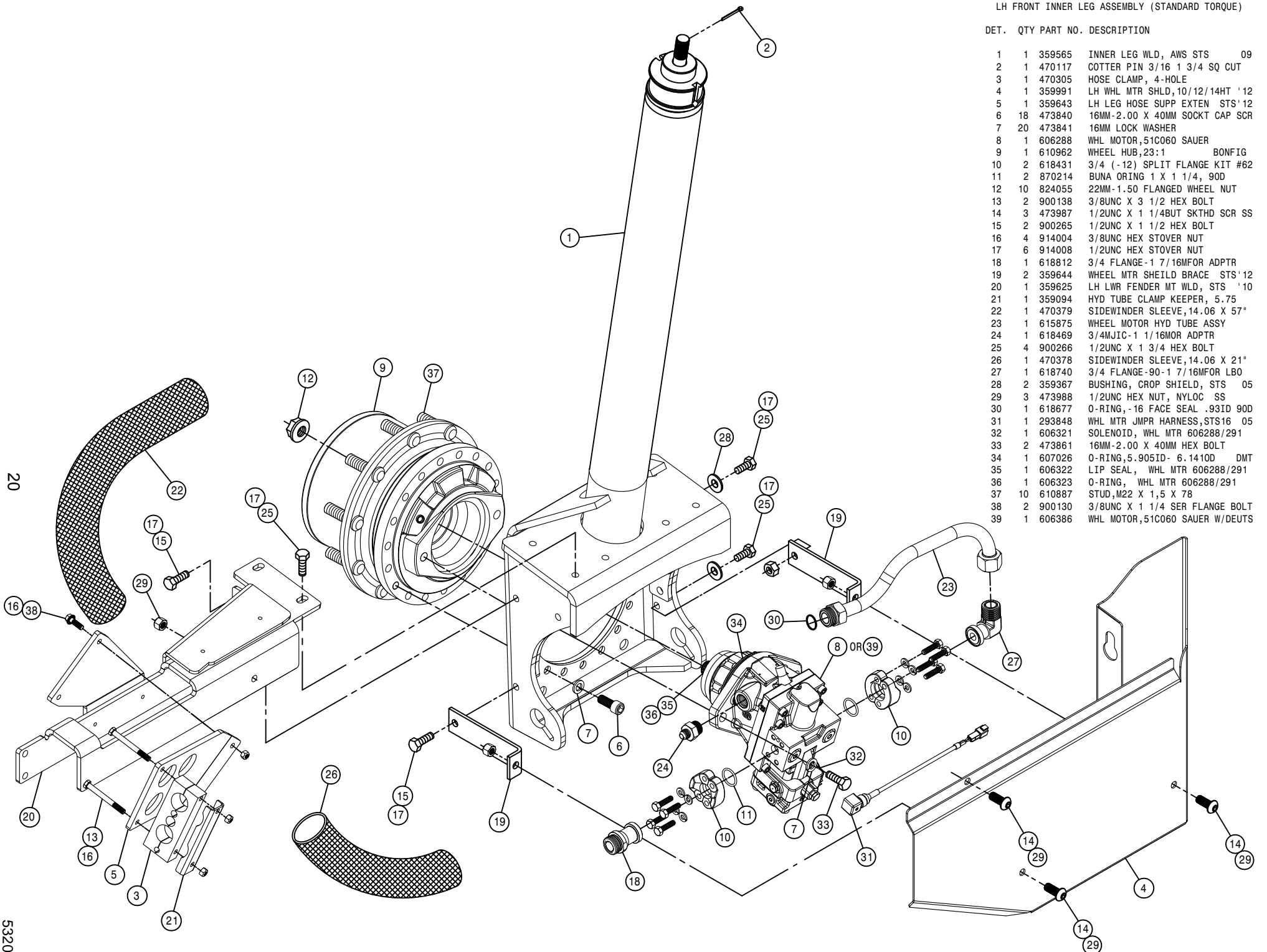

LH FRONT INNER LEG ASSEMBLY (HI TORQUE)

DET. QTY PART NO. DESCRIPTION

1	1	359565	INNER LEG WLD, AWS STS	09
2	1	470117	COTTER PIN 3/16 1 3/4 SQ CUT	
3	1	470305	HOSE CLAMP, 4-HOLE	
4	1	359991	LH WHL MTR SHLD,10/12/14HT '12	
5	1	359643	LH LEG HOSE SUPP EXTEN STS'12	
6	17	473840	16MM-2.00 X 40MM SOCKET CAP SCR	
7	17	473841	16MM LOCK WASHER	
8	1	606514	H1-B-80CC WHL MTR SAUER	
9	1	610506	TORQ HUB,25:1 CW18E	
10	2	618652	1" SPLIT FLANGE KIT	
11	2	473838	20MM-1.50 X 40MM HEX BOLT 8.8	
12	10	824055	22MM-1.50 FLANGED WHEEL NUT	
13	2	900138	3/8UNC X 3 1/2 HEX BOLT	
14	3	473987	1/2UNC X 1 1/4 BUT SKTHD SCR SS	
15	2	900265	1/2UNC X 1 1/2 HEX BOLT	
16	4	914004	3/8UNC HEX STOVER NUT	
17	6	914008	1/2UNC HEX STOVER NUT	
18	1	618473	7/16MJIC-90-7/16MOR LBO	
19	2	359644	WHEEL MTR SHEILD BRACE STS'12	
20	1	359625	LH LWR FENDER MT WLD, STS '10	
21	1	359094	HYD TUBE CLAMP KEEPER, 5.75	
22	1	470379	SIDEWINDER SLEEVE,14.06 X 57"	
23	2	618654	1" FLANGE-90-1 7/16MFOR LBO	
24	1	618602	3/4MJIC-45-7/8MOR LBO	
25	1	470378	SIDEWINDER SLEEVE,14.06 X 21"	
26	1	615909	WHL MTR TUBE ASSY STS'12	
27	4	900266	1/2UNC X 1 3/4 HEX BOLT	
28	2	359367	BUSHING, CROP SHIELD, STS 05	
29	3	473988	1/2UNC HEX NUT, NYLOC SS	
30	1	618677	O-RING, -16 FACE SEAL .93ID 90D	
31	1	294166	HI TOR SPD SNSR HARNESS STS'12	
32	2	900130	3/8UNC X 1 1/4 SER FLANGE BOLT	
33	1	615908	WHL MTR HYD TUBE ASSY STS'12	
34	1	606190	O-RING,WHL MTR HSNG SAUER	
35	2	473839	20MM FLAT WASHER	

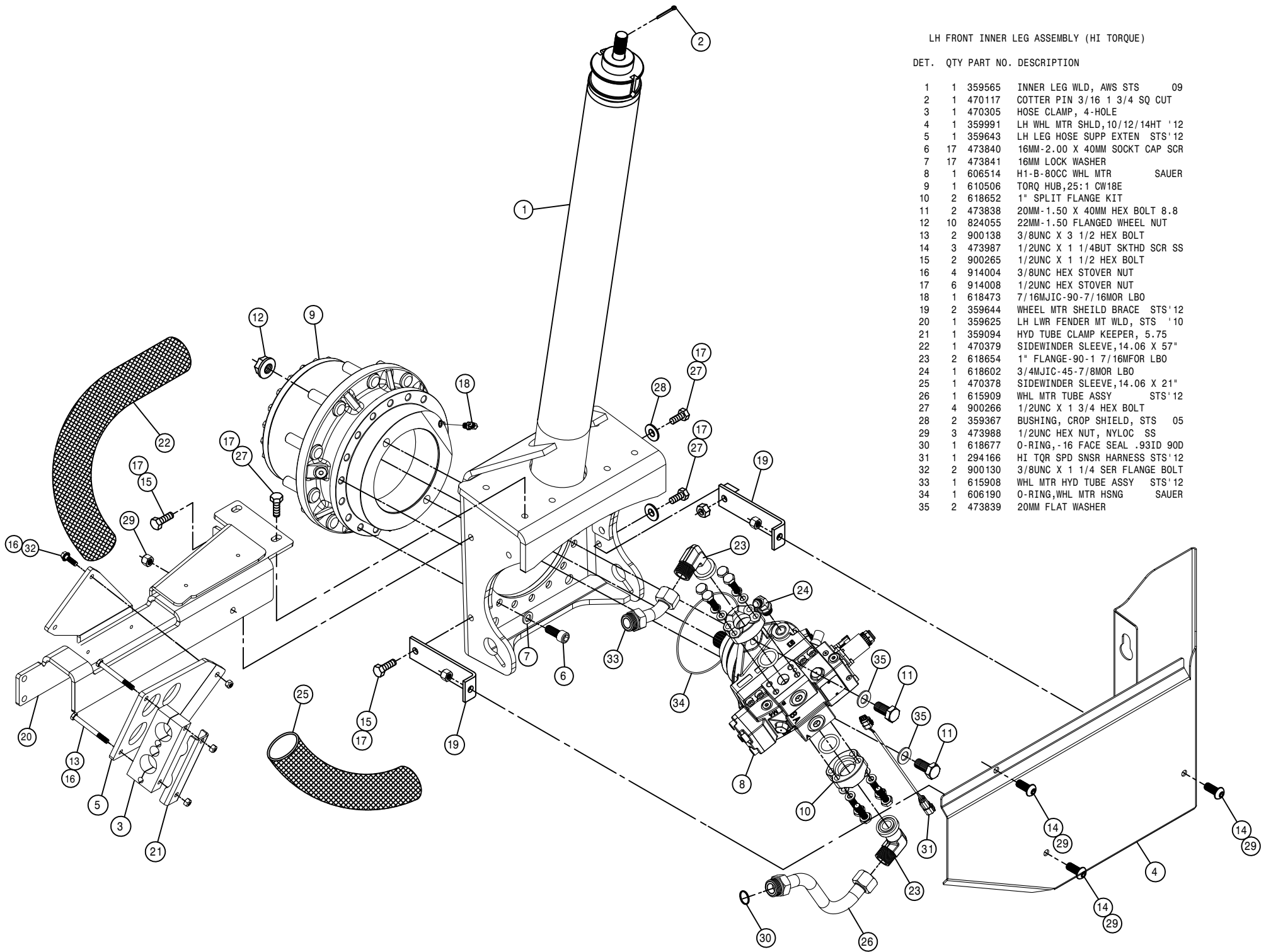

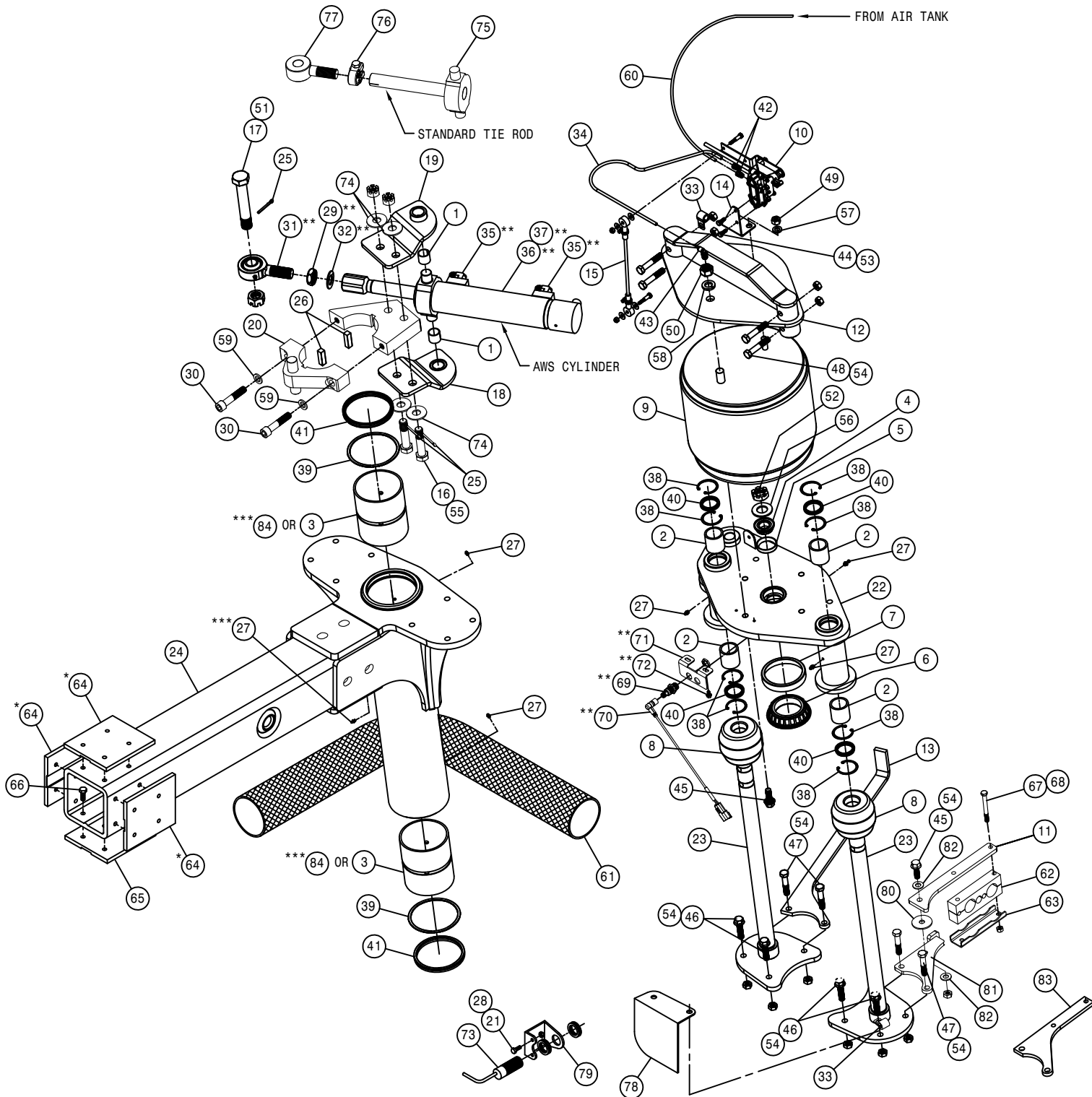

DET.	QTY	PART NO.	DESCRIPTION
1	2	121029	JOURNAL BRG, 1.00 ID X 1.00 LG
2	4	121113	BEARING, 1.50-1.81-1.86 POLYGON
3	2	121120	LEG SLEEVE BRG,AWS POLYGON
4	1	125050	BRG CONE,1.00 ID W/FACE SEAL
5	1	125051	BRG CUP FOR 125050
6	1	125052	BRG CONE, 2.687 ID W/FACE SEAL
7	1	125053	BRG CUP FOR 125052
8	2	311058	RUBBER SPRING
9	1	311080	AIRIDE SPRING, 11.81 BASE
10	1	358832	AIRIDE SPRING CTRL VALVE 98
11	1	359641	HOSE SUPP SWIVEL PLT STS'12
12	1	359333	AIRBAG TOWER TOP MT WLD,STS 05
13	1	359350	RH EXTENDED HOSE SUPPORT, STS
14	1	359369	RH LEG AIR VALVE MT, STS16 05
15	1	359544	LEG HEIGHT CTRL LNK,AWS STS09
16	2	359545	TRUNION MT BOLT, AWS STS 09
17	1	359546	STRG CYL BOLT, AWS STS 09
18	1	359547	TOP TRUNION MT WLD, AWS STS 09
19	1	359548	BTM TRUNION MT WLD, AWS STS 09
20	1	359593	STRG ARM CLAMP WLD,STS '10
21	2	900064	5/16UNC X 3/4 HEX BOLT
22	1	359556	RH AIR BAG LWR PLT WLD,AWS STS
23	2	359563	NITRO TOWER WLD, AWS STS 09
24	1	359632	OUTER LEG WLDMT,96D AWS STS'11
25	3	470117	COTTER PIN 3/16 1 3/4 SQ CUT
26	2	470447	KEY, .50 SQ X 1.69 LG
27	5	471005	GREASE ZERK, 1/4-28 X 1/2
28	2	914002	5/16UNC HEX STOVER NUT
29	1	472328	1"-12 HEX JAM NUT
30	2	472337	5/8 X 3" SOCKET HD CAP SCR
31	1	473975	ROD END,1.00 BORE,1-12 RH MALE
32	1	920508	1" LOCK WASHER
33	2	520164	CUSH CLAMP,9/16D-3/4W-.53MT
34	1	601473	HOSE, 1/4 X 18 AIR
35	2	618115	9/16MJIC-90-3/4MOR LBO
36	1	621603	HYD CYL,2.50 X 8.81 W/SENSOR
37	1	621604	REPAIR KIT, HYD CYL 621602/603
38	8	629537	187RRHOOD SNAP RING
39	2	629538	4.5 SPIROLOX RING
40	4	629620	SEAL, 1.500 ROD DIA
41	2	629621	SEAL, 4.500 ROD DIA
42	2	711036	1/8MNPT-1/4 NYL TUBE FTG
43	1	711040	1/4MNPT-90-1/4 NYL TUBE LBO
44	2	900002	1/4UNC X 3/4 HEX BOLT
45	5	900265	1/2UNC X 1 1/2 HEX BOLT
46	4	900267	1/2UNC X 2" HEX BOLT
47	4	900268	1/2UNC X 2 1/2 HEX BOLT
48	4	900269	1/2UNC X 2 3/4 HEX BOLT
49	1	910008	1/2UNC HEX NUT
50	1	910013	3/4UNF HEX NUT
51	1	910020	1-8 HEX SLOTTED NUT
52	1	910021	1-14 SLOT JAM NUT
53	2	914000	1/4UNC HEX STOVER NUT
54	13	914008	1/2UNC HEX STOVER NUT
55	2	910102	3/4UNC SLOT HEX NUT, GR8
56	1	920008	1" SAE FLAT WASHER
57	1	920504	1/2 LOCK WASHER
58	1	920506	3/4 LOCK WASHER
59	2	473841	16MM LOCK WASHER
60	1	601478	HOSE, 1/4 X 175 AIR
61	1	470311	SIDEWINDER SLEEVE,14.06 X 60"
62	1	470305	HOSE CLAMP, 4-HOLE
63	1	359094	HYD TUBE CLAMP KEEPER, 5.75
64	3	342917	TREAD ADJ. PLATE, STEEL, THD
65	4	342719	TRD ADJ BRONZE BEARING,THD-GRV
66	16	900128	3/8UNC X 3/4 HEX BOLT
67	2	900138	3/8UNC X 3 1/2 HEX BOLT
68	2	914004	3/8UNC HEX STOVER NUT
69	1	291919	INDUCTIVE SENSOR
70	1	291994	SENSOR HARNESS,MICRO-DEUTSCH
71	1	359555	SENSOR BRKT, AWS STS 09
72	2	470122	1/4UNC X 1/2 FLANGE HEX BOLT
73	1	293827	SENSOR W/DEUTSCH ASSY STS 05
74	4	483048	3/4 REG FLAT WASH,THRU-HARD
75	1	359086	REAR TIE ROD SHAFT WLD
76	1	749322	STEERING TUBE CLAMP &BOLT ASSY
77	1	359089	TIE ROD STUD WLD
78	1	359092	RH SENSOR REFLECTOR
79	1	342856	TREAD SENSOR MT
80	1	002815	SENSOR ARM WASH, NYL
81	1	359638	HOSE SUPP SWIVEL WLD STS'12
82	2	920004	1/2 SAE FLAT WASHER
83	1	359619	HOSE SUPPORT, 54" STS'10
84	2	121112	BEARING,4.51-4.85-5.74 POLYGON

NOTE: (*) FOR TREAD ADJUST OPTION REPLACE ITEM 64 WITH THREE OF ITEM 65.
 (**) ITEMS ARE FOR ALL WHEEL STEER OPTION.
 (***) ITEMS ARE A MID YEAR BEARING CHANGE.

RH REAR INNER LEG ASSEMBLY (STANDARD TORQUE)

DET. QTY PART NO. DESCRIPTION

1	1	359565	INNER LEG WLD, AWS STS	09
2	1	470117	COTTER PIN 3/16 1 3/4 SQ CUT	
3	1	470305	HOSE CLAMP, 4-HOLE	
4	1	359990	RH WHL MTR SHLD, 10/12/14HT '12	
5	1	359642	RH LEG HOSE SUPP EXTEN STS '12	
6	18	473840	16MM-2.00 X 40MM SOCKET CAP SCR	
7	20	473841	16MM LOCK WASHER	
8	1	606291	WHL MOTOR, 51C060 W/SENSR SAUER	
9	1	610965	WHEEL HUB, 27:1 W/BRAKE BONFIG	
10	1	618467	7/16MJIC-7/16MOR ADPTR	
11	2	618431	3/4 (-12) SPLIT FLANGE KIT #62	
12	2	870214	BUNA ORING 1 X 1 1/4, 90D	
13	10	824055	22MM-1.50 FLANGED WHEEL NUT	
14	2	900138	3/8UNC X 3 1/2 HEX BOLT	
15	3	473987	1/2UNC X 1 1/4 BUT SKTHD SCR SS	
16	2	900265	1/2UNC X 1 1/2 HEX BOLT	
17	4	914004	3/8UNC HEX STOVER NUT	
18	6	914008	1/2UNC HEX STOVER NUT	
19	1	618812	3/4 FLANGE-1 7/16MFOR ADPTR	
20	2	359644	WHEEL MTR SHEILD BRACE STS '12	
21	1	359624	RH LWR FENDER MT WLD, STS '10	
22	1	359094	HYD TUBE CLAMP KEEPER, 5.75	
23	1	470379	SIDEWINDER SLEEVE, 14.06 X 57"	
24	1	618740	3/4 FLANGE-90-1 7/16MFOR LBO	
25	1	618469	3/4MJIC-1 1/16MOR ADPTR	
26	1	470378	SIDEWINDER SLEEVE, 14.06 X 21"	
27	1	615875	WHEEL MOTOR HYD TUBE ASSY	
28	2	359367	BUSHING, CROP SHIELD, STS 05	
29	3	473988	1/2UNC HEX NUT, NYLOC SS	
30	1	618677	O-RING, -16 FACE SEAL .93ID 90D	
31	1	606320	SPEED SENSOR, WHL MTR 606291	
32	1	606321	SOLENOID, WHL MTR 606288/291	
33	1	293848	WHL MTR JMPR HARNESS, STS16 05	
34	4	900266	1/2UNC X 1 3/4 HEX BOLT	
35	2	473861	16MM-2.00 X 40MM HEX BOLT	
36	1	607026	O-RING, 5.905ID - 6.1410D DMT	
37	1	606322	LIP SEAL, WHL MTR 606288/291	
38	1	606323	O-RING, WHL MTR 606288/291	
39	10	610887	STUD, M22 X 1,5 X 78	
40	2	900130	3/8UNC X 1 1/4 SER FLANGE BOLT	
41	1	606387	WHL MOTOR, 51C060 W/SENSR-DEUTS	

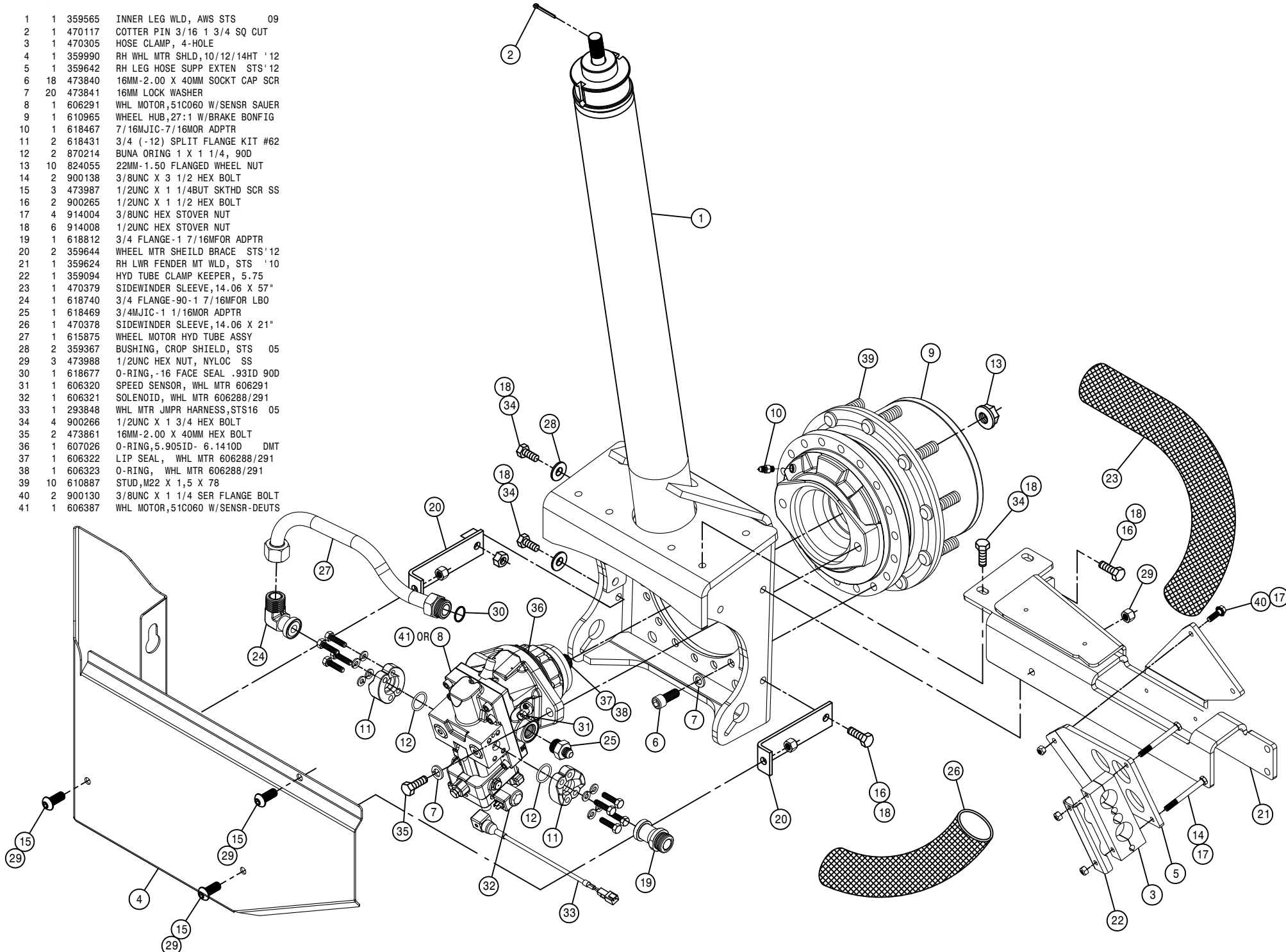

23

532023

RH REAR INNER LEG ASSEMBLY (HI TORQUE)

DET. QTY PART NO. DESCRIPTION

1	1	359565	INNER LEG WLD, AWS STS	09
2	1	470117	COTTER PIN 3/16 1 3/4 SQ CUT	
3	1	470305	HOSE CLAMP, 4-HOLE	
4	1	359990	RH WHL MTR SHLD,10/12/14HT '12	
5	1	359642	RH LEG HOSE SUPP EXTEN STS'12	
6	17	473840	16MM-2.00 X 40MM SOCKET CAP SCR	
7	17	473841	16MM LOCK WASHER	
8	1	606514	H1-B-80CC WHL MTR	SAUER
9	1	610507	TORQ HUB,31:1 CW18E	
10	2	618652	1" SPLIT FLANGE KIT	
11	2	473838	20MM-1.50 X 40MM HEX BOLT 8.8	
12	10	824055	22MM-1.50 FLANGED WHEEL NUT	
13	2	900138	3/8UNC X 3 1/2 HEX BOLT	
14	3	473987	1/2UNC X 1 1/4 BUT SKTHD SCR SS	
15	2	900265	1/2UNC X 1 1/2 HEX BOLT	
16	4	914004	3/8UNC HEX STOVER NUT	
17	6	914008	1/2UNC HEX STOVER NUT	
18	1	618473	7/16MJIC-90-7/16MOR LBO	
19	2	359644	WHEEL MTR SHEILD BRACE STS'12	
20	1	359624	RH LWR FENDER MT WLD, STS '10	
21	1	359094	HYD TUBE CLAMP KEEPER, 5.75	
22	1	470379	SIDEWINDER SLEEVE,14.06 X 57"	
23	2	618654	1" FLANGE-90-1 7/16MFOR LBO	
24	1	618602	3/4MJIC-45-7/8MOR LBO	
25	1	470378	SIDEWINDER SLEEVE,14.06 X 21"	
26	1	615909	WHL MTR TUBE ASSY	STS'12
27	4	900266	1/2UNC X 1 3/4 HEX BOLT	
28	2	359367	BUSHING, CROP SHIELD, STS	05
29	3	473988	1/2UNC HEX NUT, NYLOC SS	
30	1	618677	O-RING,-16 FACE SEAL .93ID 90D	
31	1	294166	HI TOR SPD SNSR HARNESS STS'12	
32	2	900130	3/8UNC X 1 1/4 SER FLANGE BOLT	
33	1	615908	WHL MTR HYD TUBE ASSY	STS'12
34	1	606190	O-RING,WHL MTR HSNQ	SAUER
35	2	473839	20MM FLAT WASHER	

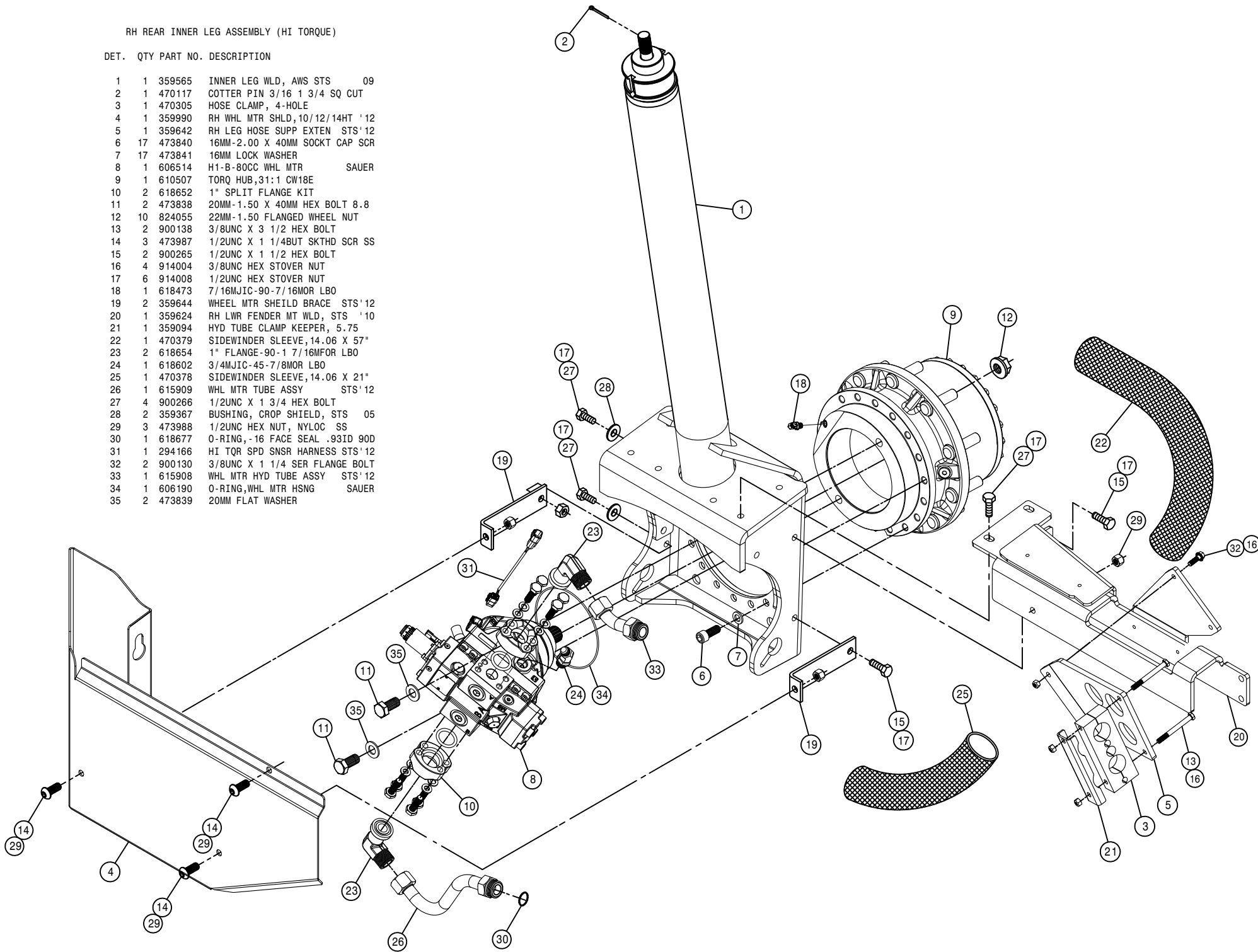

LEFT REAR OUTER LEG ASSEMBLY

DET.	QTY	PART NO.	DESCRIPTION
1	2	121029	JOURNAL BRG, 1.00 ID X 1.00 LG
2	4	121113	BEARING, 1.50-1.81-1.86 POLYGON
3	2	121120	LEG SLEEVE BRG,AWS POLYGON
4	1	125050	BRG CONE,1.00 ID W/FACE SEAL
5	1	125051	BRG CUP FOR 125050
6	1	125052	BRG CONE, 2.687 ID W/FACE SEAL
7	1	125053	BRG CUP FOR 125052
8	2	311058	RUBBER SPRING
9	1	311080	AIRIDE SPRING, 11.81 BASE
10	1	358832	AIRIDE SPRING CTRL VALVE
11	1	359641	HOSE SUPP SWIVEL PLT STS'12
12	1	359333	AIRBAG TOWER TOP MT WLD,STS 05
13	1	359351	LH EXTENDED HOSE SUPPORT, STS
14	1	359370	LH LEG AIR VALVE MT, STS16 05
15	1	359544	LEG HEIGHT CTRL LNK,AWS STS09
16	2	359545	TRUNION MT BOLT, AWS STS 09
17	1	359546	STRG CYL BOLT, AWS STS 09
18	1	359547	TOP TRUNION MT WLD, AWS STS 09
19	1	359548	BTM TRUNION MT WLD, AWS STS 09
20	1	359593	STRG ARM CLAMP WLD,STS '10
21	2	900064	5/16UNC X 3/4 HEX BOLT
22	1	359557	LH AIR BAG LWR PLT WLD,AWS STS
23	2	359563	NITRO TOWER WLD, AWS STS 09
24	1	359632	OUTER LEG WLDMT,96D AWS STS'11
25	3	470117	COTTER PIN 3/16 1 3/4 SQ CUT
26	2	470447	KEY, .50 SQ X 1.69 LG
27	5	471005	GREASE ZERK, 1/4-28 X 1/2
28	2	914002	5/16UNC HEX STOVER NUT
29	1	472328	1" -12 HEX JAM NUT
30	2	472337	5/8 X 3" SOCKET HD CAP SCR
31	1	473975	ROD END,1.00 BORE,1-12 RH MALE
32	1	920508	1" LOCK WASHER
33	2	520164	CUSH CLAMP, 9/16D-3/4W-.531MT
34	1	601473	HOSE, 1/4 X 18 AIR
35	2	618115	9/16MJIC-90-3/4MOR LBO
36	1	621603	HYD CYL,2.50 X 8.81 W/SENSOR
37	1	621604	REPAIR KIT, HYD CYL 621602/603
38	8	629537	187RRHOOD SNAP RING
39	2	629538	4.5 SPIROLOX RING
40	4	629620	SEAL, 1.500 ROD DIA
41	2	629621	SEAL, 4.500 ROD DIA
42	2	711036	1/8MNPT-1/4 NYL TUBE FTG
43	1	711040	1/4MNPT-90-1/4 NYL TUBE LBO
44	2	900002	1/4UNC X 3/4 HEX BOLT
45	5	900265	1/2UNC X 1 1/2 HEX BOLT
46	4	900267	1/2UNC X 2" HEX BOLT
47	4	900268	1/2UNC X 2 1/2 HEX BOLT
48	4	900269	1/2UNC X 2 3/4 HEX BOLT
49	1	910008	1/2UNC HEX NUT
50	1	910013	3/4UNF HEX NUT
51	1	910020	1-8 HEX SLOTTED NUT
52	1	910021	1-14 SLOT JAM NUT
53	2	914008	1/4UNC HEX STOVER NUT
54	13	914008	1/2UNC HEX STOVER NUT
55	2	910102	3/4UNC SLOT HEX NUT, GR8
56	1	920008	1" SAE FLAT WASHER
57	1	920504	1/2 LOCK WASHER
58	1	920506	3/4 LOCK WASHER
59	2	473841	16MM LOCK WASHER
60	1	601476	HOSE, 1/4 X 120 AIR
61	1	470311	SIDEWINDER SLEEVE,14.06 X 60"
62	1	470305	HOSE CLAMP, 4-HOLE
63	1	359094	HYD TUBE CLAMP KEEPER, 5.75
64	3	342917	TREAD ADJ PLATE, STEEL, THD
65	4	342719	TRD ADJ BRONZE BEARING,THD-GRV
66	16	900128	3/8UNC X 3/4 HEX BOLT
67	2	900138	3/8UNC X 3 1/2 HEX BOLT
68	2	914004	3/8UNC HEX STOVER NUT
69	1	291919	INDUCTIVE SENSOR
70	1	291994	SENSOR HARNESS,MICRO-DEUTSCH
71	1	359555	SENSOR BRKT, AWS STS 09
72	2	470122	1/4UNC X 1/2 FLANGE HEX BOLT
73	1	293827	SENSOR W/DEUTSCH ASSY STS 05
74	4	483048	3/4 REG FLAT WASH,THRU-HARD
75	1	359086	REAR TIE ROD SHAFT WLD
76	1	748322	STEERING TUBE CLAMP &BOLT ASSY
77	1	359089	TIE ROD STUD WLD
78	1	359093	LH SENSOR REFLECTOR
79	1	342856	TREAD SENSOR MT
80	1	002815	SENSOR ARM WASH, NYL
81	1	359638	HOSE SUPP SWIVEL WLD STS'12
82	2	920004	1/2 SAE FLAT WASHER
83	1	359619	HOSE SUPPORT, 54" STS'10
84	2	121112	BEARING,4.51-4.85-5.74 POLYGON

NOTE: (*) FOR TREAD ADJUST OPTION REPLACE ITEM 64 WITH THREE OF ITEM 65.
 (***) ITEMS ARE A MID YEAR BEARING CHANGE.

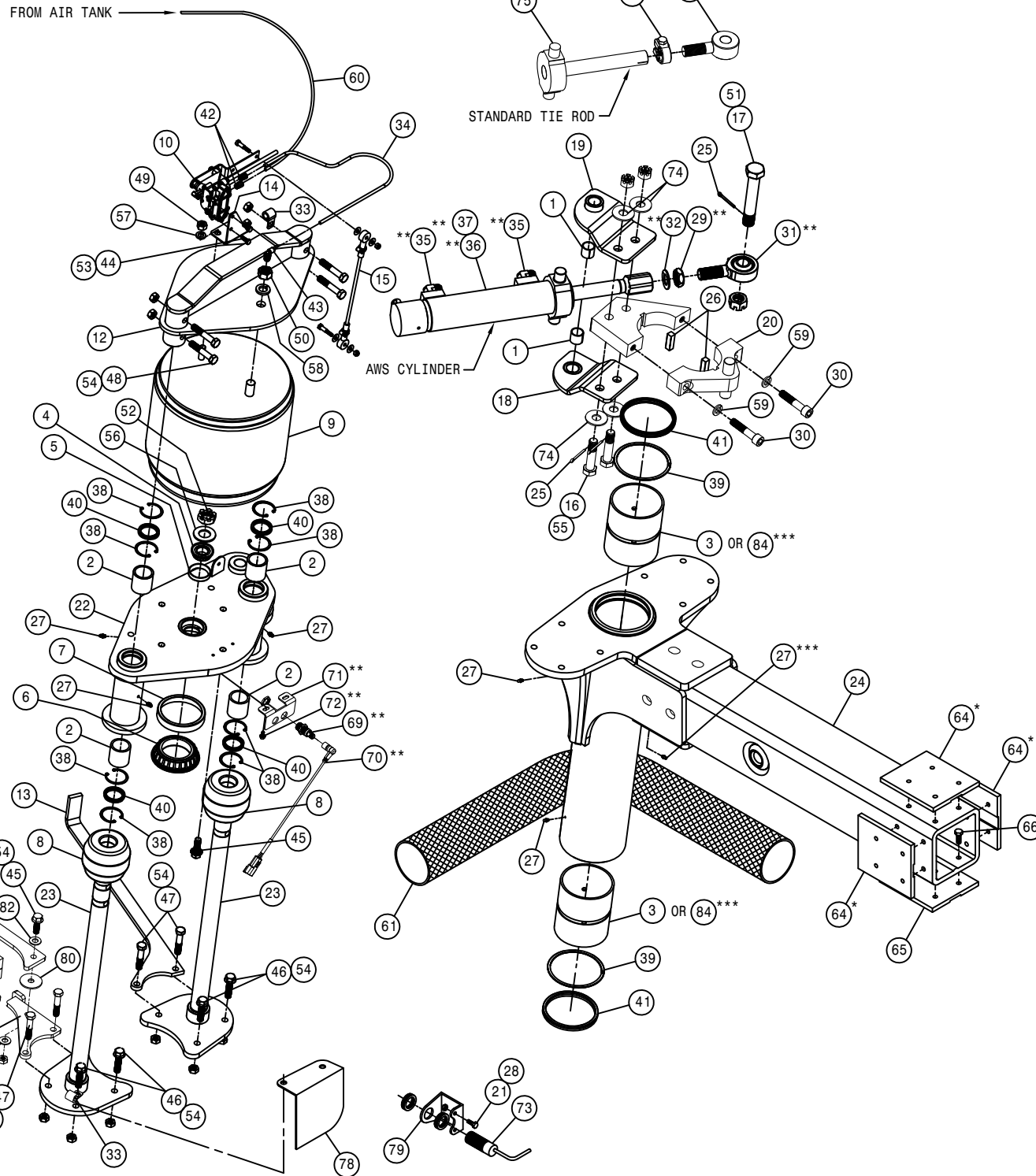

LH REAR INNER LEG ASSEMBLY (STANDARD TORQUE)

DET. QTY PART NO. DESCRIPTION

1	1	359565	INNER LEG WLD, AWS STS	09
2	1	470117	COTTER PIN 3/16 1 3/4 SQ CUT	
3	1	470305	HOSE CLAMP, 4-HOLE	
4	1	359991	LH WHL MTR SHLD,10/12/14HT '12	
5	1	359643	LH LEG HOSE SUPP EXTEN STS'12	
6	18	473840	16MM-2.00 X 40MM SOCKET CAP SCR	
7	20	473841	16MM LOCK WASHER	
8	1	606291	WHL MOTOR,51C060 W/SENSR SAUER	
9	1	610965	WHEEL HUB,27:1 W/BRAKE BONFIG	
10	1	618740	3/4 FLANGE-90-1 7/16MFOR LBO	
11	2	618431	3/4 (-12) SPLIT FLANGE KIT #62	
12	2	870214	BUNA ORING 1 X 1 1/4, 90D	
13	10	824055	22MM-1.50 FLANGED WHEEL NUT	
14	2	900138	3/8UNC X 3 1/2 HEX BOLT	
15	3	473987	1/2UNC X 1 1/4BUT SKTHD SCR SS	
16	2	900265	1/2UNC X 1 1/2 HEX BOLT	
17	4	914004	3/8UNC HEX STOVER NUT	
18	6	914008	1/2UNC HEX STOVER NUT	
19	1	618812	3/4 FLANGE-1 7/16MFOR ADPTR	
20	2	359644	WHEEL MTR SHEILD BRACE STS'12	
21	1	359625	LH LWR FENDER MT WLD, STS '10	
22	1	359094	HYD TUBE CLAMP KEEPER, 5.75	
23	1	470378	SIDEWINDER SLEEVE,14.06 X 21"	
24	1	470656	SIDEWINDER SLEEVE,14.06 X 67"	
25	1	615875	WHEEL MOTOR HYD TUBE ASSY	
26	1	618469	3/4MJIC-1 1/16MOR ADPTR	
27	1	618467	7/16MJIC-7/16MOR ADPTR	
28	2	359367	BUSHING, CROP SHIELD, STS	05
29	3	473988	1/2UNC HEX NUT, NYLOC SS	
30	1	618677	O-RING, -16 FACE SEAL .93ID 90D	
31	1	606320	SPEED SENSOR, WHL MTR 606291	
32	1	606321	SOLENOID, WHL MTR 606288/291	
33	1	293848	WHL MTR JMPR HARNESS, STS16	05
34	4	900266	1/2UNC X 1 3/4 HEX BOLT	
35	2	473861	16MM-2.00 X 40MM HEX BOLT	
36	1	607026	O-RING,5.905ID- 6.1410D DMT	
37	1	606322	LIP SEAL, WHL MTR 606288/291	
38	1	606323	O-RING, WHL MTR 606288/291	
39	10	610887	STUD,M22 X 1,5 X 78	
40	2	900130	3/8UNC X 1 1/4 SER FLANGE BOLT	
41	1	606387	WHL MOTOR,51C060 W/SENSR-DEUTS	

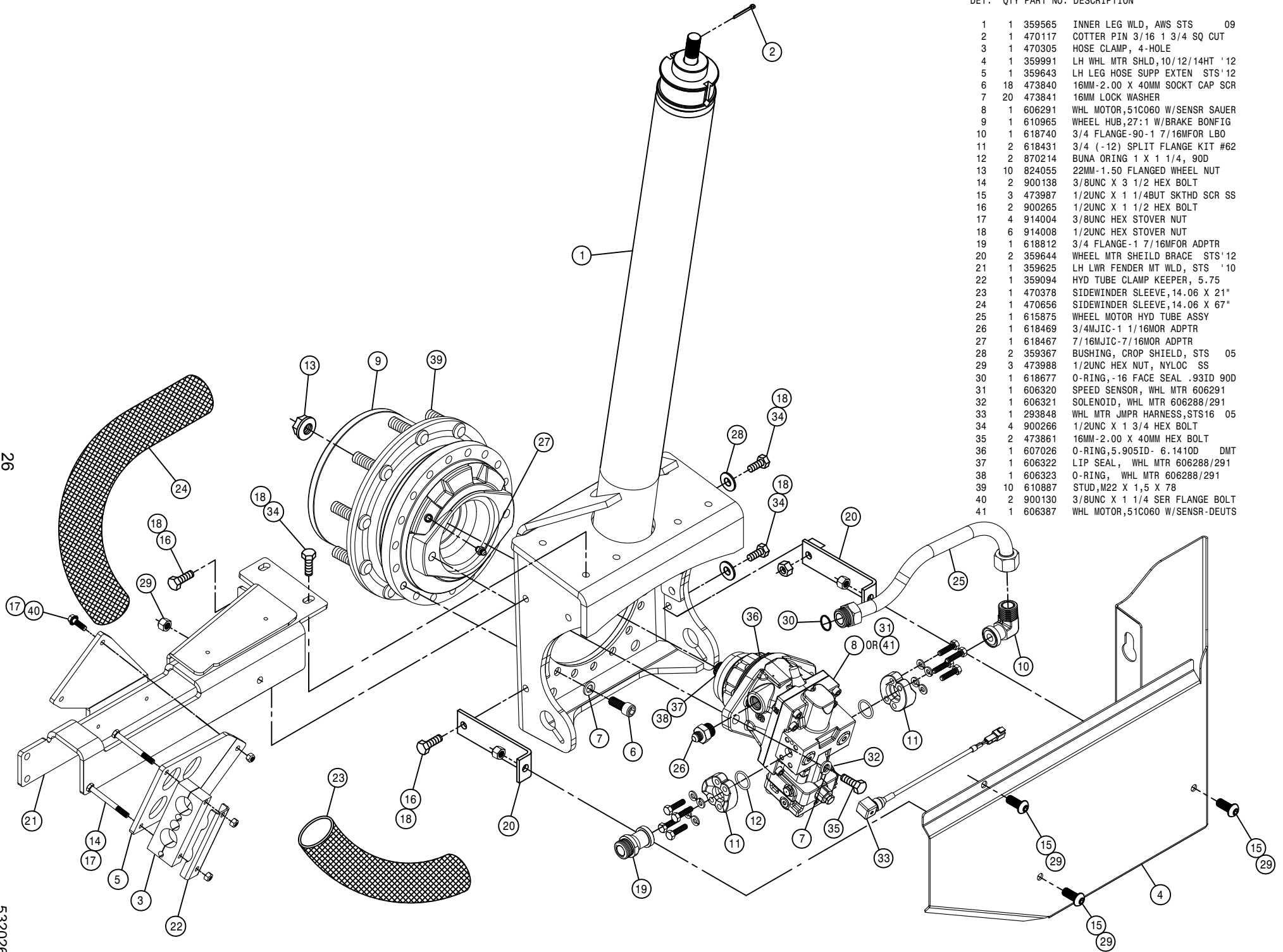

LH REAR INNER LEG ASSEMBLY (HI TORQUE)

DET. QTY PART NO. DESCRIPTION

1	1	359565	INNER LEG WLD, AWS STS	09
2	1	470117	COTTER PIN 3/16 1 3/4 SQ CUT	
3	1	470305	HOSE CLAMP, 4-HOLE	
4	1	359991	LH WHL MTR SHLD, 10/12/14HT '12	
5	1	359643	LH LEG HOSE SUPP EXTEN STS'12	
6	17	473840	16MM-2.00 X 40MM SOCKT CAP SCR	
7	17	473841	16MM LOCK WASHER	
8	1	606514	H1-B-80CC WHL MTR SAUER	
9	1	610507	TORQ HUB, 31:1 CW18E	
10	2	618652	1" SPLIT FLANGE KIT	
11	2	473838	20MM-1.50 X 40MM HEX BOLT 8.8	
12	10	824055	22MM-1.50 FLANGED WHEEL NUT	
13	2	900138	3/8UNC X 3 1/2 HEX BOLT	
14	3	473987	1/2UNC X 1 1/4 BUT SKTHD SCR SS	
15	2	900265	1/2UNC X 1 1/2 HEX BOLT	
16	4	914004	3/8UNC HEX STOVER NUT	
17	6	914008	1/2UNC HEX STOVER NUT	
18	1	618473	7/16MJIC-90-7/16MOR LBO	
19	2	359644	WHEEL MTR SHIELD BRACE STS'12	
20	1	359625	LH LWR FENDER MT WLD, STS '10	
21	1	359094	HYD TUBE CLAMP KEEPER, 5.75	
22	1	470656	SIDEWINDER SLEEVE, 14.06 X 67"	
23	2	618654	1" FLANGE-90-1 7/16MFOR LBO	
24	1	618602	3/4MJIC-45-7/8MOR LBO	
25	1	470378	SIDEWINDER SLEEVE, 14.06 X 21"	
26	1	615909	WHL MTR TUBE ASSY STS'12	
27	4	900266	1/2UNC X 1 3/4 HEX BOLT	
28	2	359367	BUSHING, CROP SHIELD, STS 05	
29	3	473988	1/2UNC HEX NUT, NYLOC SS	
30	1	618677	O-RING, -16 FACE SEAL .93ID 90D	
31	1	294166	HI TOR SPD SNSR HARNESS STS'12	
32	2	900130	3/8UNC X 1 1/4 SER FLANGE BOLT	
33	1	615908	WHL MTR HYD TUBE ASSY STS'12	
34	1	606190	O-RING, WHL MTR HSNG SAUER	
35	2	473839	20MM FLAT WASHER	

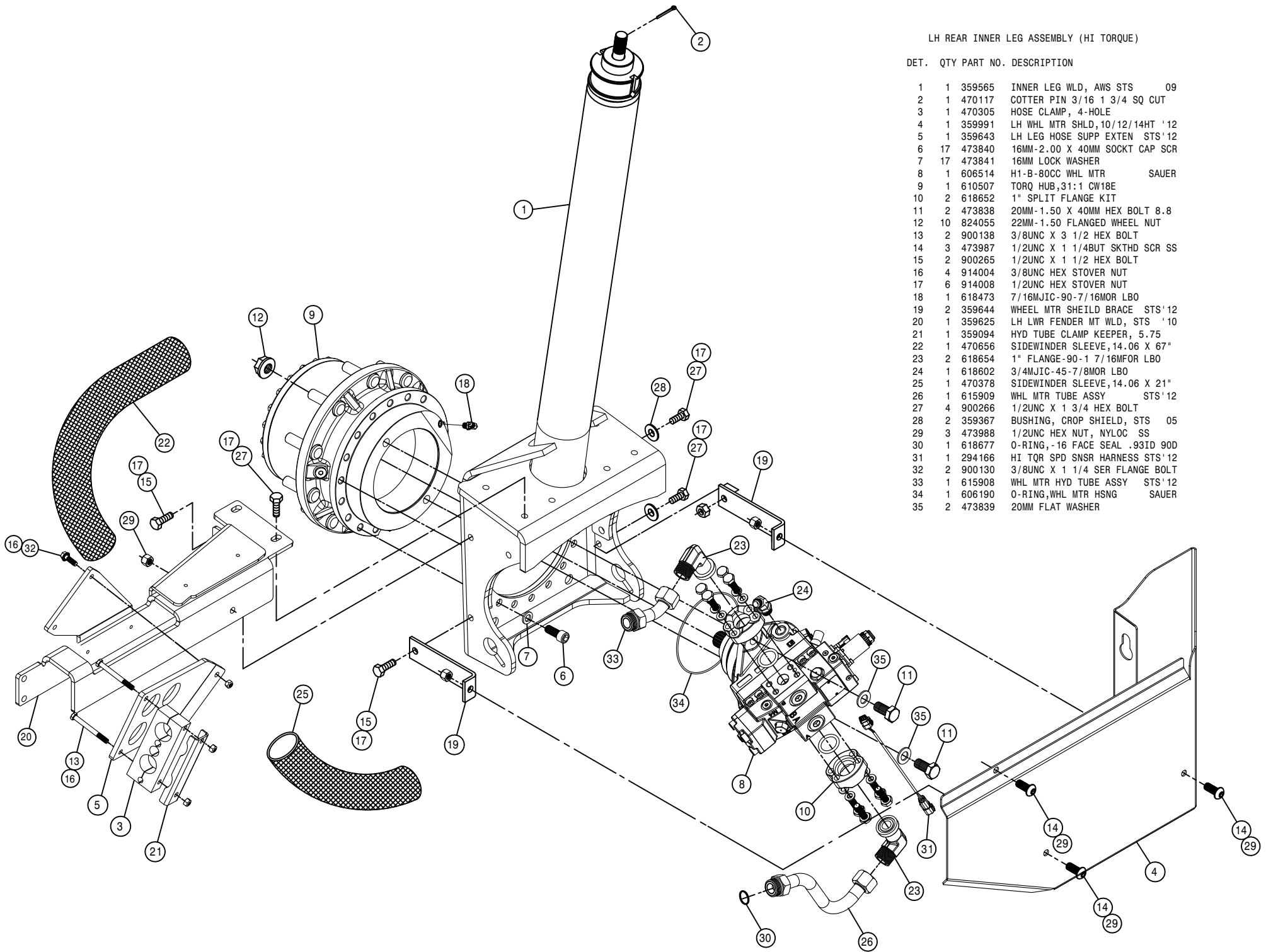

FRONT TREAD ADJUST ASSEMBLY

DET. QTY PART NO. DESCRIPTION

DET.	QTY	PART NO.	DESCRIPTION
1	16	483018	1" EXTERNAL TOOTH LOCK WASHER
2	2	616070	04-451TC-04MJBH-06MOR-11.00H/A
3	2	616071	04-451TC-04MJBH-06MOR-13.00H/A
4	4	618525	7/16-20 BULKHEAD LOCKNUT
5	2	621552	HYD CYL, 3.00 X 16.00 X 1.375
6	16	900128	3/8UNC X 3/4 HEX BOLT
7	8	900303	1/2UNF X 1 1/2 HEX BOLT
8	4	900391	3/4UNC X 1 1/2 FLT SOC CAP SCR
9	16	900395	1"UNC X 2 1/2 SOCKET CAP SCR
10	16	910101	1-8 HEX JAM NUT
11	1	361689	REAR TRD ADJ ACCESS PLT WLD 04
12	2	621553	REPAIR KIT, HYD CYL 621552
13	8	920504	1/2 LOCK WASHER
14	4	342721	TRD ADJ BRONZE BRG W/DIMPLES
15	1	361576	FRT TREAD ADJ ACCESS PLT WLD
16	2	361581	TRD ADJ CYL PIVOT PIN, M/F
17	4	361583	TRD ADJ CYL SPACER, M/F
18	2	361582	TREAD ADJ CYL PIN, OUTER LEG
19	4	342719	TRD ADJ BRONZE BEARING, THD-GRV

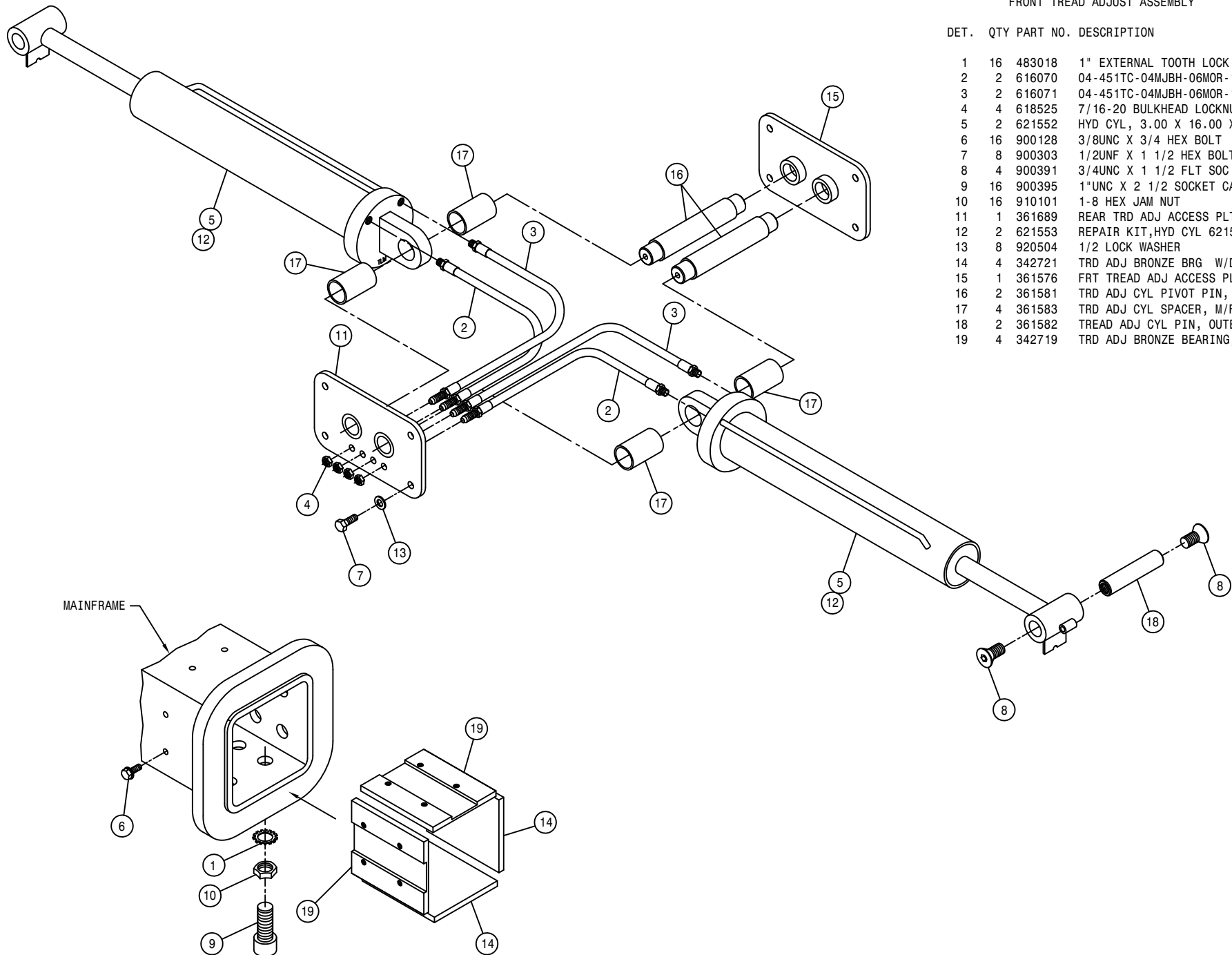

MAINFRAME

REAR TREAD ADJUST ASSEMBLY

DET. QTY PART NO. DESCRIPTION

DET.	QTY	PART NO.	DESCRIPTION
1	16	483018	1" EXTERNAL TOOTH LOCK WASHER
2	2	616070	04-451TC-04MJBH-06MOR-11.00H/A
3	2	616071	04-451TC-04MJBH-06MOR-13.00H/A
4	4	618525	7/16-20 BULKHEAD LOCKNUT
5	2	621552	HYD CYL, 3.00 X 16.00 X 1.375
6	16	900128	3/8UNC X 3/4 HEX BOLT
7	8	900303	1/2UNF X 1 1/2 HEX BOLT
8	4	900391	3/4UNC X 1 1/2 FLT SOC CAP SCR
9	16	900395	1"UNC X 2 1/2 SOCKET CAP SCR
10	16	910101	1-8 HEX JAM NUT
11	2	621553	REPAIR KIT, HYD CYL 621552
12	4	342721	TRD ADJ BRONZE BRG W/DIMPLES
13	8	920504	1/2 LOCK WASHER
14	1	361579	REAR TRD ADJ ACCESS PLT WLD 00
15	1	361697	TRD ADJ ACCESS PLT WLD 07
16	2	361581	TRD ADJ CYL PIVOT PIN, M/F
17	4	361583	TRD ADJ CYL SPACER, M/F
18	2	361582	TRD ADJ CYL PIN, OUTER LEG
19	4	342719	TRD ADJ BRONZE BEARING, THD-GRV

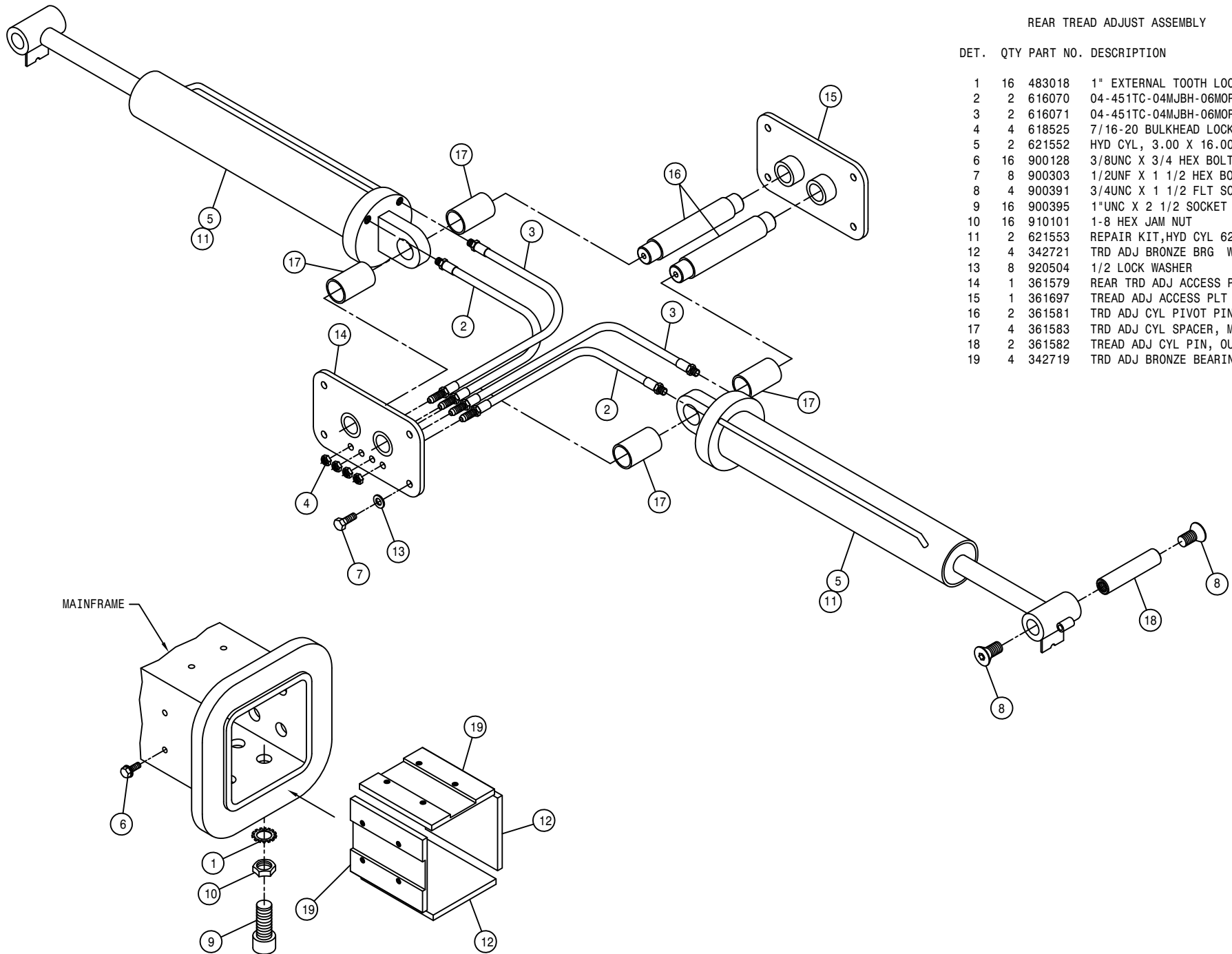

MAINFRAME

FRONT NO TREAD ADJUST ASSEMBLY

DET. QTY PART NO. DESCRIPTION

DET.	QTY	PART NO.	DESCRIPTION
1	16	483018	1" EXTERNAL TOOTH LOCK WASHER
2	2	361964	INNER TREAD ADJ PLT WLD, STS' 11
3	2	361967	OUTER TREAD ADJ PLT WLD, STS' 11
4	2	361970	TREAD ADJ TIE ROD WLD, STS' 11
5	2	473805	ROLL PIN, 1/4 X 1 1/2
6	16	900128	3/8UNC X 3/4 HEX BOLT
7	8	900303	1/2UNF X 1 1/2 HEX BOLT
8	4	900391	3/4UNC X 1 1/2 FLT SOC CAP SCR
9	16	900395	1"UNC X 2 1/2 SOCKET CAP SCR
10	16	910101	1-8 HEX JAM NUT
11	1	361689	REAR TRD ADJ ACCESS PLT WLD 04
12	4	900403	3/4UNC X 2" HEX BOLT
13	8	920504	1/2 LOCK WASHER
14	4	342721	TRD ADJ BRONZE BRG W/DIMPLES
15	1	361576	FRT TREAD ADJ ACCESS PLT WLD
16	2	361581	TRD ADJ CYL PIVOT PIN, M/F
17	8	361973	TREAD ADJ TIE ROD SPACR, STS' 11
18	2	361582	TREAD ADJ CYL PIN, OUTER LEG
19	4	342917	TREAD ADJ PLATE, STEEL, THD
20	4	914012	3/4UNC HEX STOVER NUT

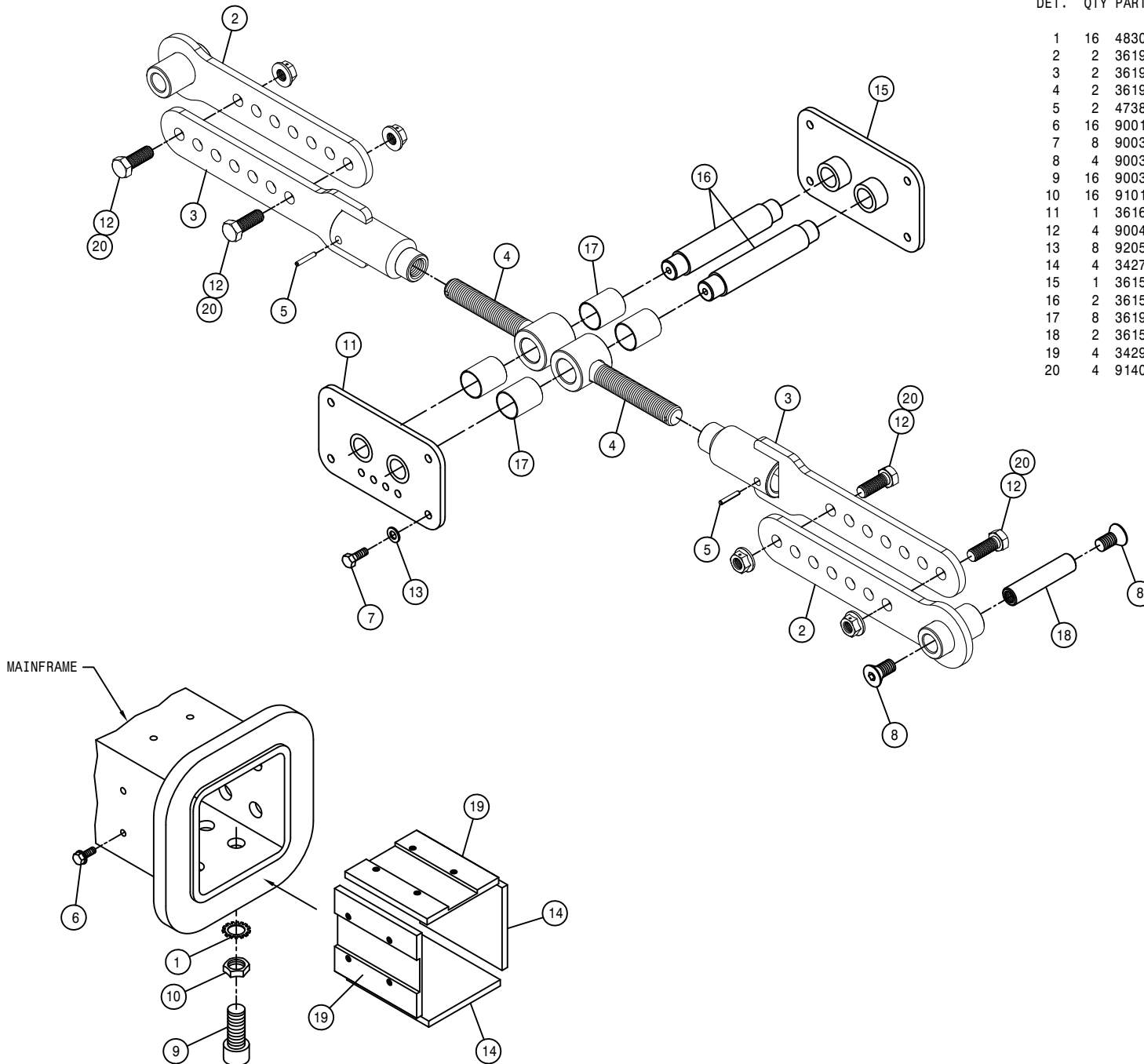

REAR NO TREAD ADJUST ASSEMBLY

DET. QTY PART NO. DESCRIPTION

1	16	483018	1" EXTERNAL TOOTH LOCK WASHER
2	2	361964	INNER TREAD ADJ PLT WLD,STS'11
3	2	361967	OUTER TREAD ADJ PLT WLD,STS'11
4	2	361970	TREAD ADJ TIE ROD WLD, STS'11
5	2	473805	ROLL PIN, 1/4 X 1 1/2
6	16	900128	3/8UNC X 3/4 HEX BOLT
7	8	900303	1/2UNC X 1 1/2 HEX BOLT
8	4	900391	3/4UNC X 1 1/2 FLT SOC CAP SCR
9	16	900395	1"UNC X 2 1/2 SOCKET CAP SCR
10	16	910101	1-8 HEX JAM NUT
11	4	900403	3/4UNC X 2" HEX BOLT
12	4	342721	TRD ADJ BRONZE BRG W/DIMPLES
13	8	920504	1/2 LOCK WASHER
14	1	361579	REAR TRD ADJ ACCESS PLT WLD 00
15	1	361697	TREAD ADJ ACCESS PLT WLD 07
16	2	361581	TRD ADJ CYL PIVOT PIN, M/F
17	8	361973	TREAD ADJ TIE ROD SPACR,STS'11
18	2	361582	TREAD ADJ CYL PIN, OUTER LEG
19	4	342917	TREAD ADJ PLATE, STEEL, THD
20	4	914012	3/4UNC HEX STOVER NUT

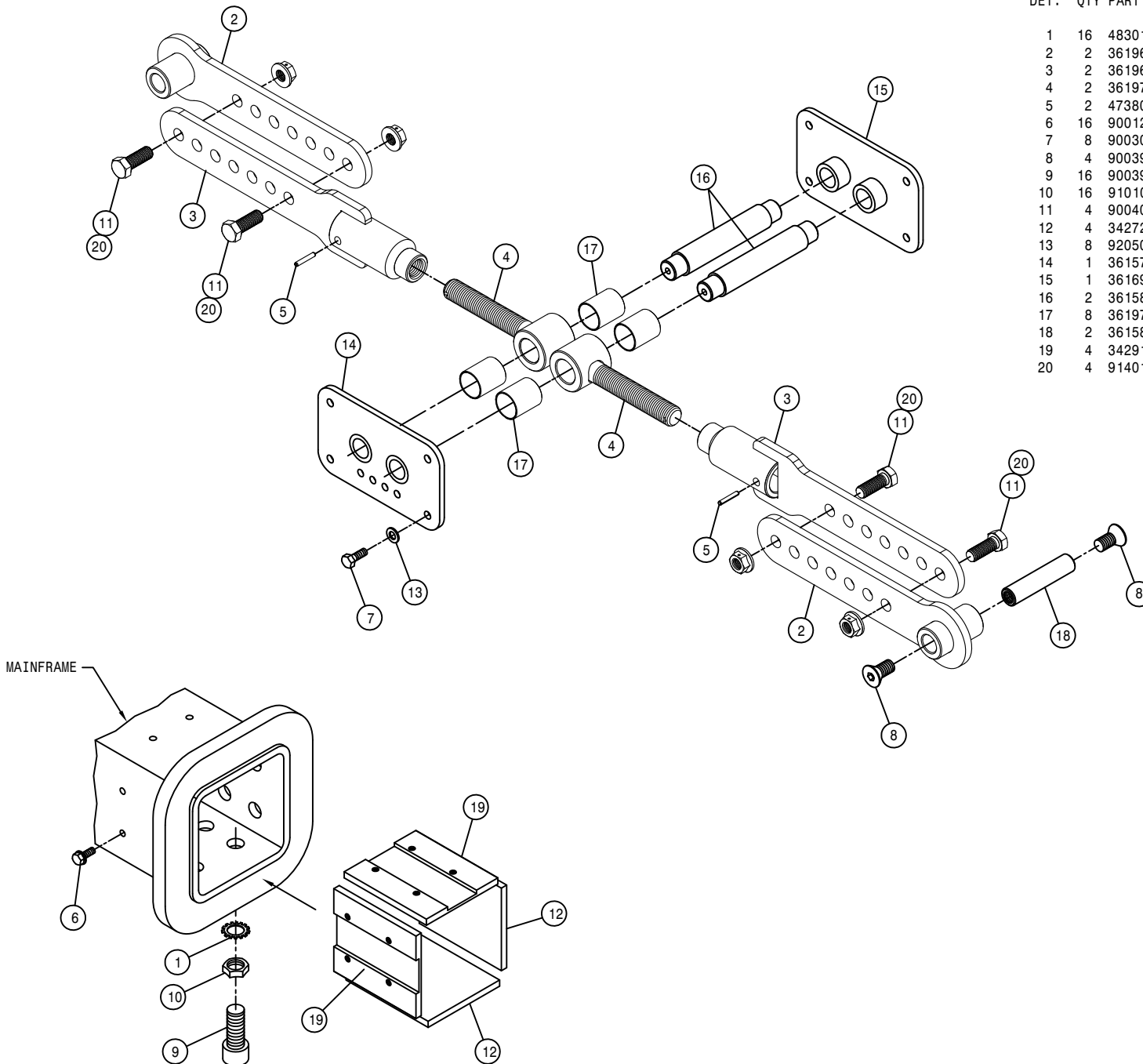

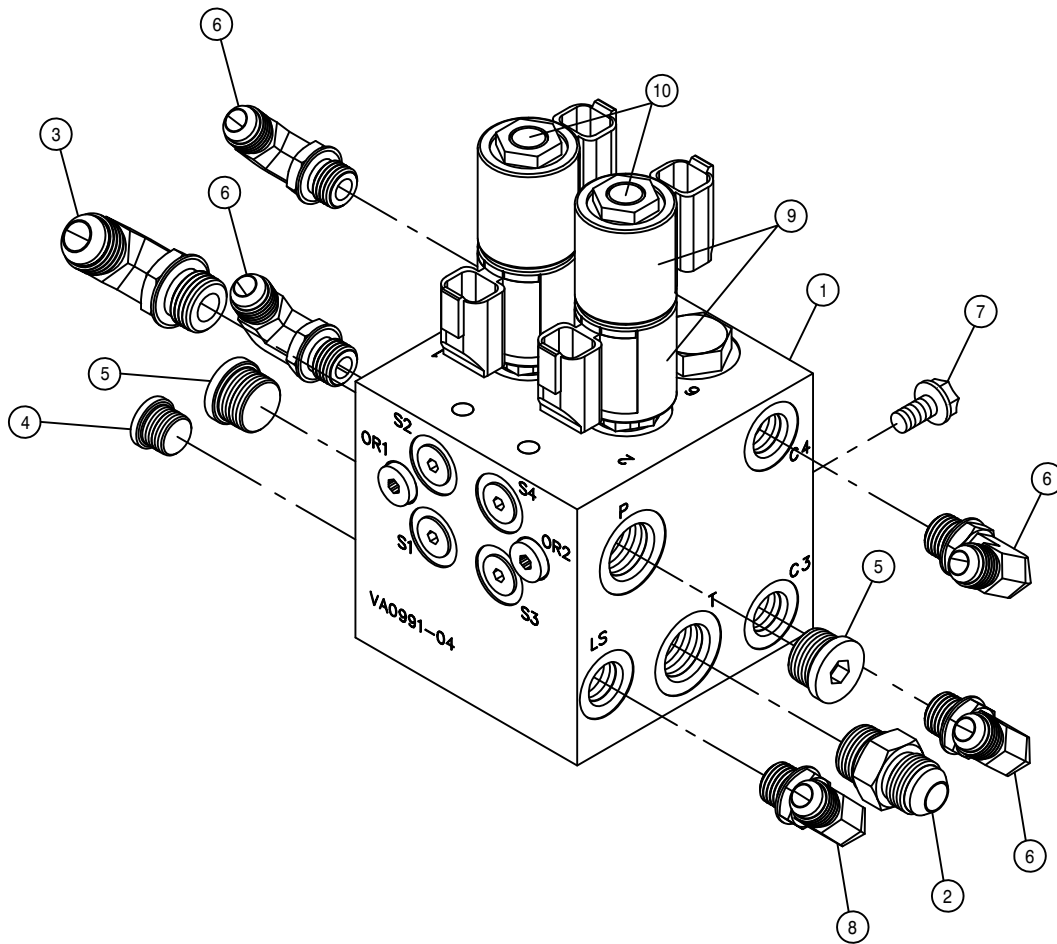

FRONT TREAD ADJUST VALVE ASSEMBLY

DET.	QTY	PART NO.	DESCRIPTION	
1	1	606249	MANIFOLD, TRD ADJ	PWRSYS
2	1	611125	3/4MJC-3/4MOR ADPTR	
3	1	618241	3/4MJC-90-3/4MOR LBO	
4	1	618754	9/16MOR PLUG, HEX SOCKET	
5	2	618755	3/4MOR PLUG, HEX SOCKET	
6	4	618119	9/16MJC-90-9/16MOR LBO	
7	2	900064	5/16UNC X 3/4 HEX BOLT	
8	1	618499	7/16MJC-90-9/16MOR LBO	
9	4	606266	#8 COIL W/DEUTSCH FOR 606210	
10	2	606358	CARTRIDGE SP08-47D,PROP,3POS	

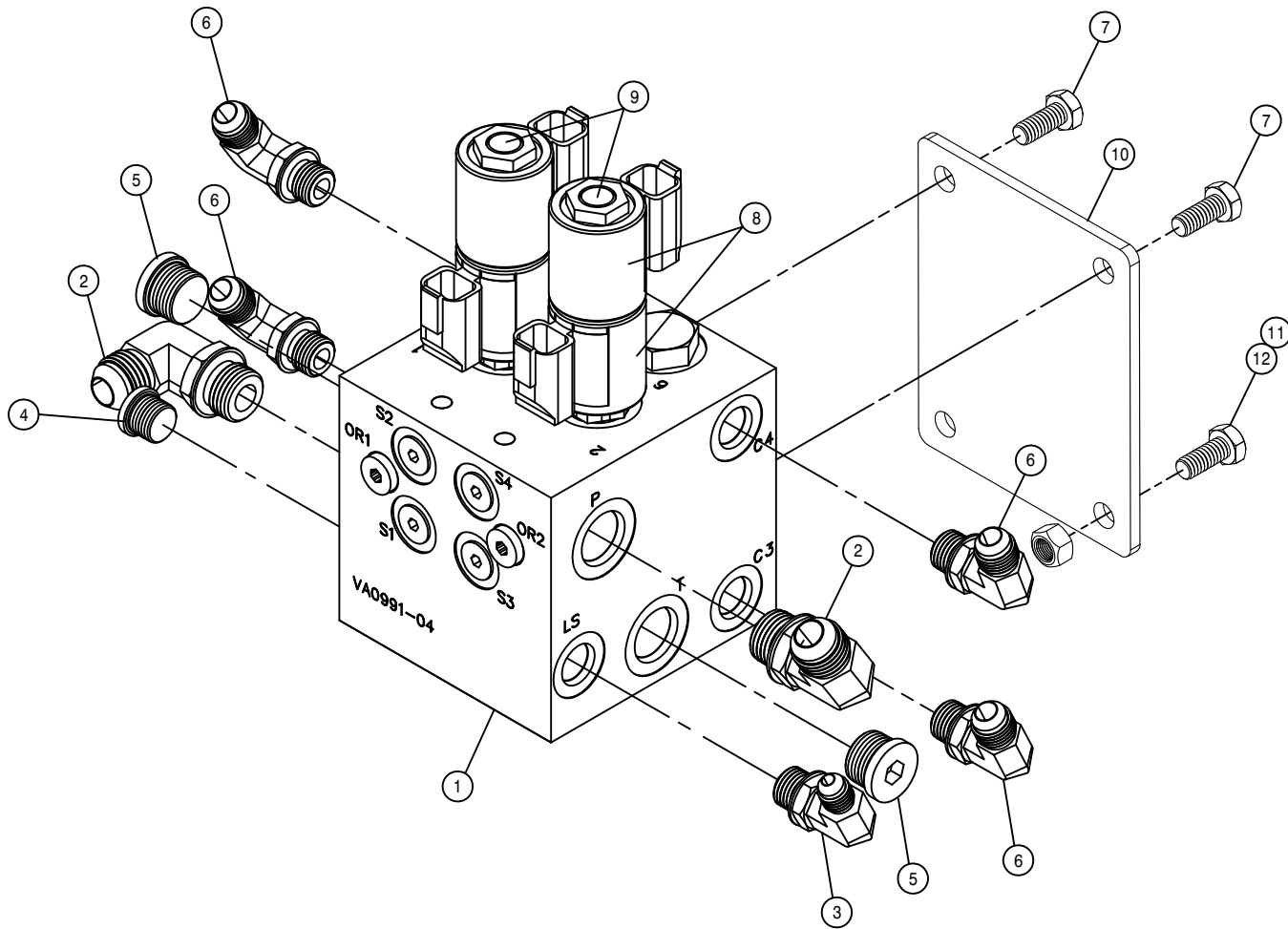

REAR TREAD ADJUST VALVE ASSEMBLY

DET.	QTY	PART NO.	DESCRIPTION	PWRSYS
	1	606249	MANIFOLD,TRD ADJ	
	2	618241	3/4MJIC-90-3/4MOR LBO	
	3	618499	7/16MJIC-90-9/16MOR LBO	
	4	618754	9/16MOR PLUG, HEX SOCKET	
	5	618755	3/4MOR PLUG, HEX SOCKET	
	6	618119	9/16MJIC-90-9/16MOR LBO	
	7	900064	5/16UNC X 3/4 HEX BOLT	
	8	606266	#8 COIL W/DEUTSCH FOR 606210	
	9	606358	CARTRIDGE SPO8-47D,PROP,3POS	
	10	361719	TRD ADJ VLV EXT MT,M/F STS' 12	
	11	470087	3/8UNC HEX FLANGE LOCK NUT	
	12	900129	3/8UNC X 1" SERR FLANGE BOLT	

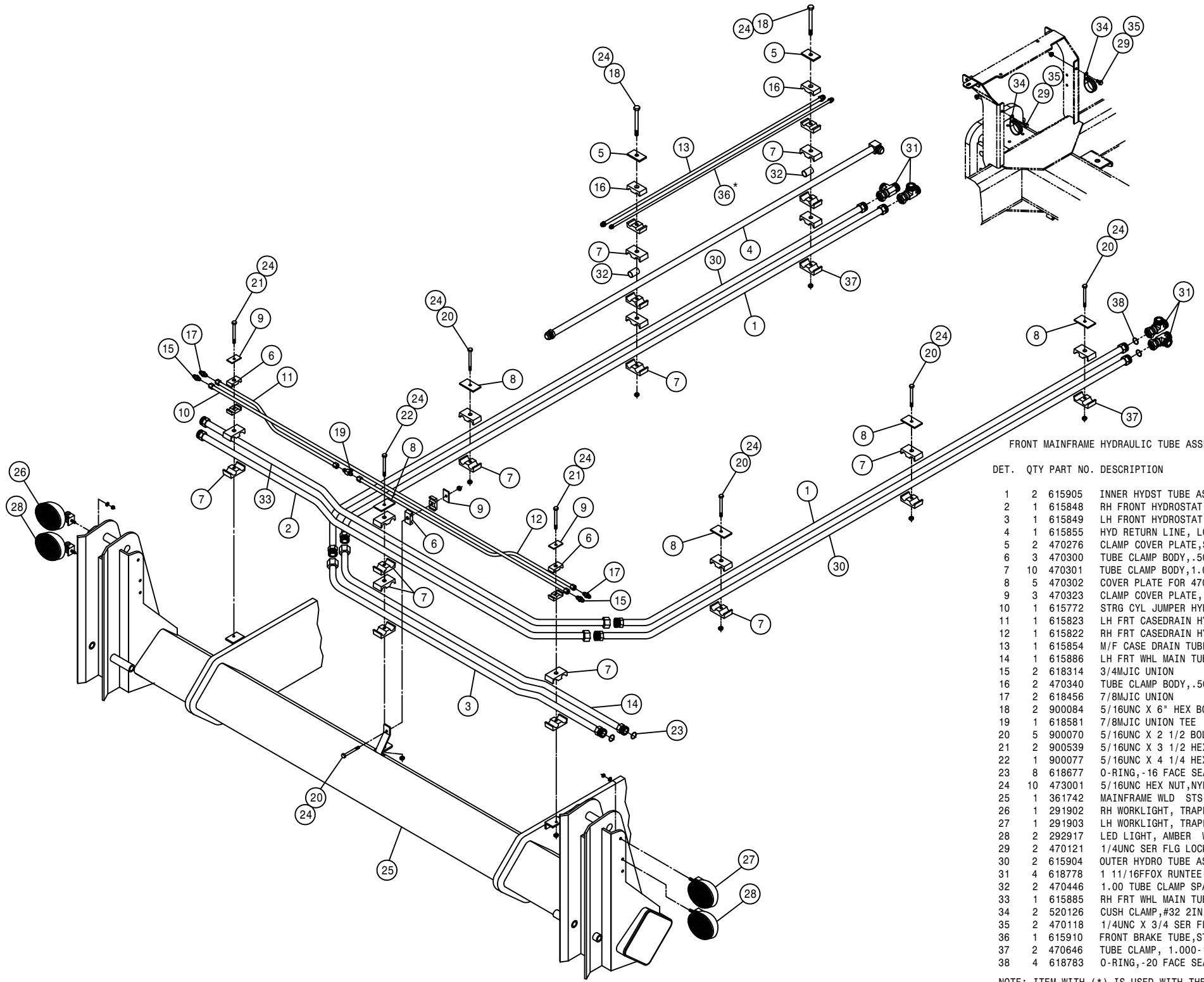

FRONT MAINFRAME HYDRAULIC TUBE ASSEMBLY

DET.	QTY	PART NO.	DESCRIPTION
1	2	615905	INNER HYDST TUBE ASSY, 10/12' 12
2	1	615848	RH FRONT HYDROSTAT TUBE ASSY
3	1	615849	LH FRONT HYDROSTAT TUBE ASSY
4	1	615855	HYD RETURN LINE, LONG, STS10 07
5	2	470276	CLAMP COVER PLATE, SNGL, 2.55LG
6	3	470300	TUBE CLAMP BODY, .500-.625
7	10	470301	TUBE CLAMP BODY, 1.00-1.00
8	5	470302	COVER PLATE FOR 470301
9	3	470323	CLAMP COVER PLATE, SNGL 2.04LG
10	1	615772	STRG CYL JUMPER HYD TUBE ASSY
11	1	615823	LH FRT CASEDRAIN HYD TUBE ASSY
12	1	615822	RH FRT CASEDRAIN HYD TUBE ASSY
13	1	615854	M/F CASE DRAIN TUBE, STS10 07
14	1	615886	LH FRT WHL MAIN TUBE ASY, STS09
15	2	618314	3/4MJIC UNION
16	2	470340	TUBE CLAMP BODY, .500-.750
17	2	618456	7/8MJIC UNION
18	2	900084	5/16UNC X 6" HEX BOLT
19	1	618581	7/8MJIC UNION TEE
20	5	900070	5/16UNC X 2 1/2 BOLT
21	2	900539	5/16UNC X 3 1/2 HEX BOLT
22	1	900077	5/16UNC X 4 1/4 HEX BOLT
23	8	618677	O-RING, -16 FACE SEAL .93ID 90D
24	10	473001	5/16UNC HEX NUT, NYLOC
25	1	361742	MAINFRAME WLD STS 10/12 07
26	1	291902	RH WORKLIGHT, TRAPEZOID GLASS
27	1	291903	LH WORKLIGHT, TRAPEZOID GLASS
28	2	292917	LED LIGHT, AMBER W/JUMPER
29	2	470121	1/4UNC SER FLG LOCK NUT
30	2	615904	OUTER HYDRO TUBE ASSY, 10/12' 12
31	4	618778	1 11/16FFOX RUNTEE- 1 11/16MFOR
32	2	470446	1.00 TUBE CLAMP SPACER
33	1	615885	RH FRT WHL MAIN TUBE ASY, STS09
34	2	520126	CUSH CLAMP, #32 2IN X 5/8W
35	2	470118	1/4UNC X 3/4 SER FLG BOLT
36	1	615910	FRONT BRAKE TUBE, STS10/12 '12
37	2	470646	TUBE CLAMP, 1.000-1.000 (PAIR)
38	4	618783	O-RING, -20 FACE SEAL 1.18ID

NOTE: ITEM WITH (*) IS USED WITH THE HI-TORQUE OPTION.

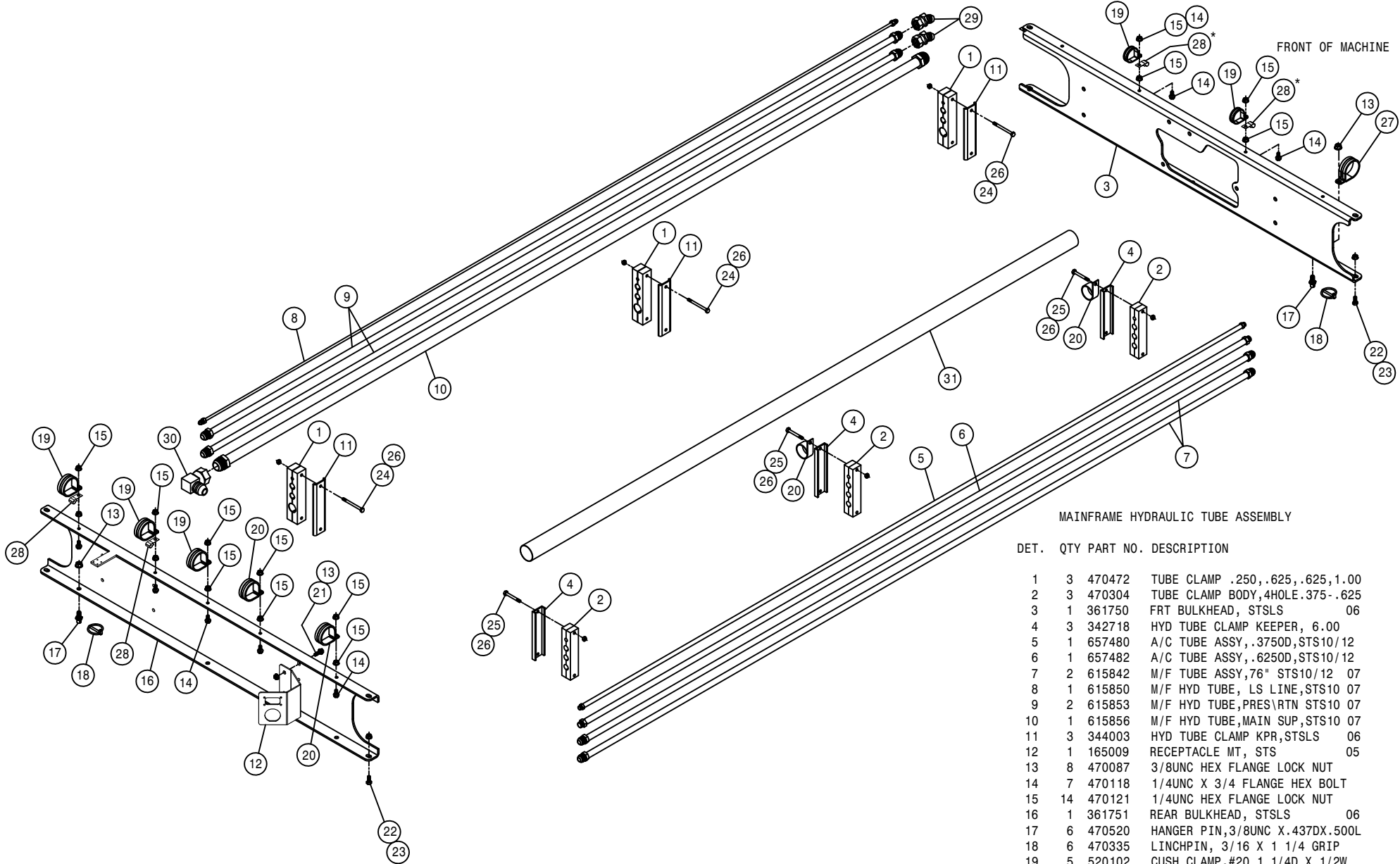

MAINFRAME HYDRAULIC TUBE ASSEMBLY

DET. QTY PART NO. DESCRIPTION

DET.	QTY	PART NO.	DESCRIPTION
1	3	470472	TUBE CLAMP .250, .625, .625, 1.00
2	3	470304	TUBE CLAMP BODY, 4HOLE .375 - .625
3	1	361750	FRT BULKHEAD, STSLS 06
4	3	342718	HYD TUBE CLAMP KEEPER, 6.00
5	1	657480	A/C TUBE ASSY, .3750D, STS10/12
6	1	657482	A/C TUBE ASSY, .6250D, STS10/12
7	2	615842	M/F TUBE ASSY, 76" STS10/12 07
8	1	615850	M/F HYD TUBE, LS LINE, STS10 07
9	2	615853	M/F HYD TUBE, PRES\RTN STS10 07
10	1	615856	M/F HYD TUBE, MAIN SUP, STS10 07
11	3	344003	HYD TUBE CLAMP KPR, STSLS 06
12	1	165009	RECEPTACLE MT, STS 05
13	8	470087	3/8UNC HEX FLANGE LOCK NUT
14	7	470118	1/4UNC X 3/4 FLANGE HEX BOLT
15	14	470121	1/4UNC HEX FLANGE LOCK NUT
16	1	361751	REAR BULKHEAD, STSLS 06
17	6	470520	HANGER PIN, 3/8UNC X .437DX .500L
18	6	470335	LINCHPIN, 3/16 X 1 1/4 GRIP
19	5	520102	CUSH CLAMP, #20 1 1/4D X 1/2W
20	4	520126	CUSH CLAMP, #32 2IN X 5/8W
21	2	900128	3/8UNC X 3/4 HEX BOLT
22	8	900129	3/8UNC X 1" SERR FLANGE BOLT
23	8	910004N	3/8UNC FLANGE CNTR LOCK NUT
24	6	900008	1/4UNC X 2 1/2 HEX BOLT
25	6	900007	1/4UNC X 2" HEX BOLT
26	12	470089	1/4UNC HEX NYLOC NUT, 316 SS
27	1	520161	CUSH CLAMP, #32 2"D-3/4W LOOP
28	4	520128	CUSH J CLAMP, #9 9/16D X 3/4W
29	2	618628	7/8MJIC-45-7/8FJIC SWIV LBO
30	1	618640	1 5/16MJ-90-1 5/16FJ SWIV LBO
31	1	470374	SIDEWINDER SLEEVE, 8.50 X 80"

NOTE: ITEMS WITH (*) ARE USED WITH THE SIDE FILL OPTION.

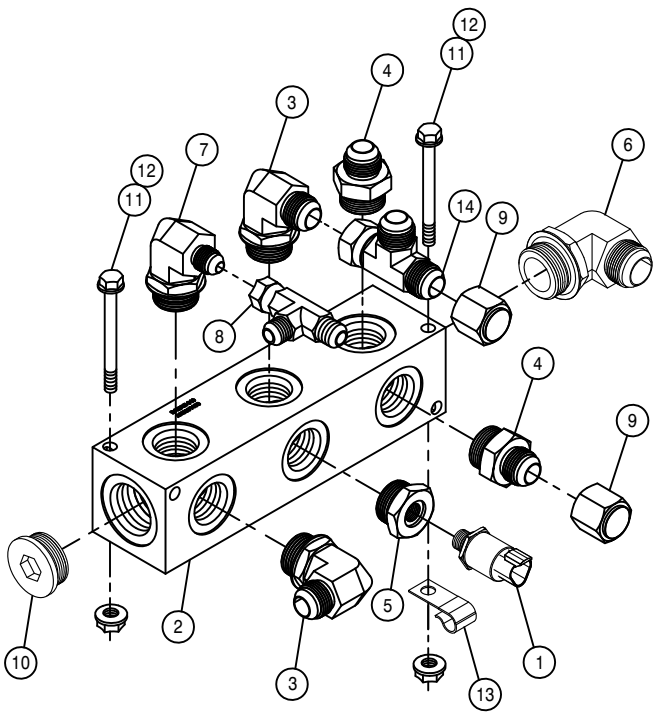

HYDRAULIC SUPPLY MANIFOLD ASSEMBLY

DET.	QTY	PART NO.	DESCRIPTION
	1	606347	PRESSURE TRANSDUCER,7500PSI
	1	606246	MANIFOLD, #16 3-STN 180
	2	618302	1 1/16MJIC-90-1 5/16MOR LBO
	4	618308	1 1/16MJIC-1 5/16MOR ADPTR
	5	618397	1 5/16MOR-9/16FOR ADPTR
	6	618883	1 5/16MJIC-90-1 5/8MOR LBO
	7	618475	3/4MJIC-90-1 5/16MOR LBO
	8	618451	3/4FJIC SW RUN TEE-3/4MJIC
	9	618533	1 1/16FJIC CAP NUT
	10	618759	1 5/8MOR PLUG, HEX SOCKET
	11	900140	3/8UNC X 4" HEX BOLT
	12	470087	3/8UNC HEX FLANGE LOCK NUT
	13	520128	CUSH J CLAMP,#9 9/16D X 3/4W
	14	618487	1 1/16FJ SW RUN TEE-1 1/16MJ

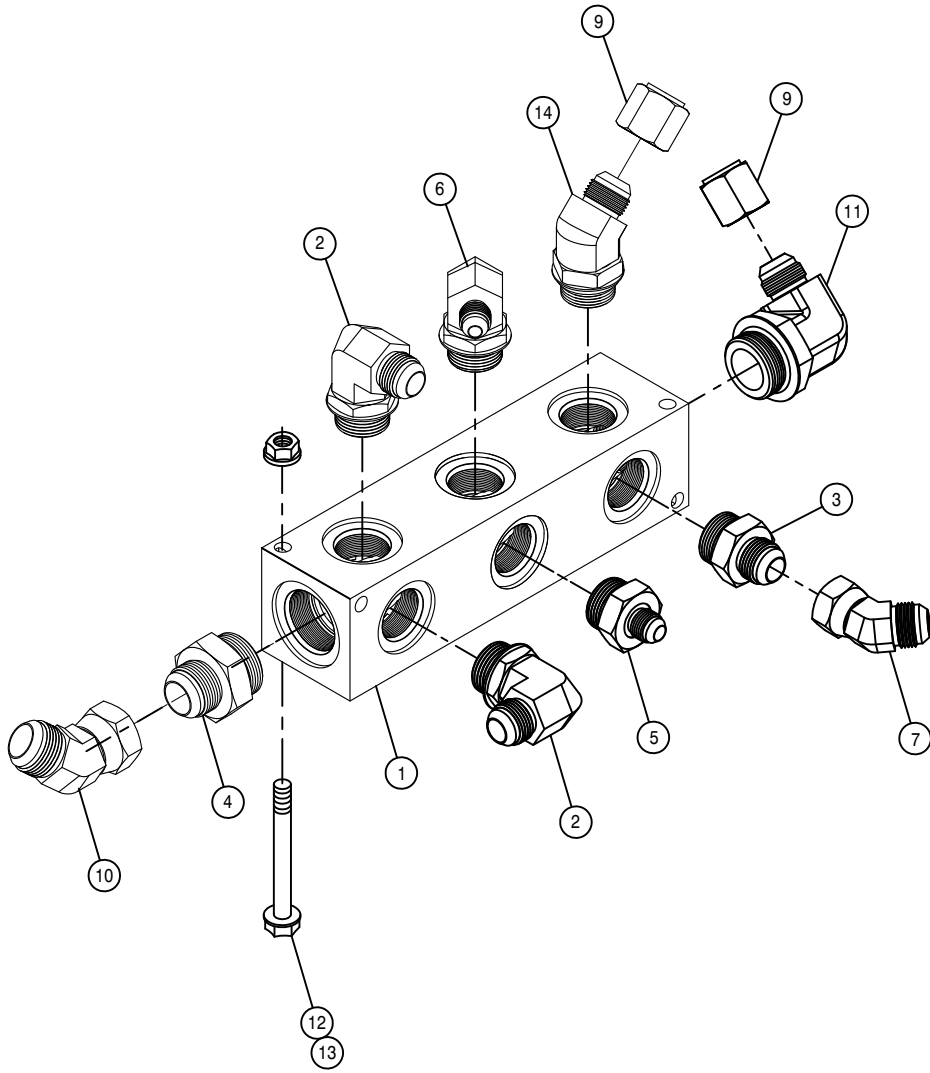

FRONT RETURN MANIFOLD ASSEMBLY

DET. QTY PART NO. DESCRIPTION

1	1	606246	MANIFOLD, #16 3-STN 180
2	2	618302	1 1/16MJIC-90-1 5/16MOR LBO
3	1	618308	1 1/16MJIC-1 5/16MOR ADPTR
4	1	618455	1 5/16MJIC-1 5/8MOR ADPTR
5	1	618470	3/4MJIC-1 5/16MOR ADPTR
6	1	618475	3/4MJIC-90-1 5/16MOR LBO
7	1	618529	1 1/16MJ-45-1 1/16FJ SWIV LBO
8	1	618532	3/4FJIC CAP NUT
9	2	618533	1 1/16FJIC CAP NUT
10	1	618630	1 5/16MJ-45-1 5/16FJ SWIV LBO
11	1	618842	1 1/16MJIC-90-1 5/8MOR LBO
12	2	470087	3/8UNC HEX FLANGE LOCK NUT
13	2	900139	3/8UNC X 3 3/4 HEX BOLT
14	1	618831	1 1/16MJIC-45-1 5/16MOR LBO

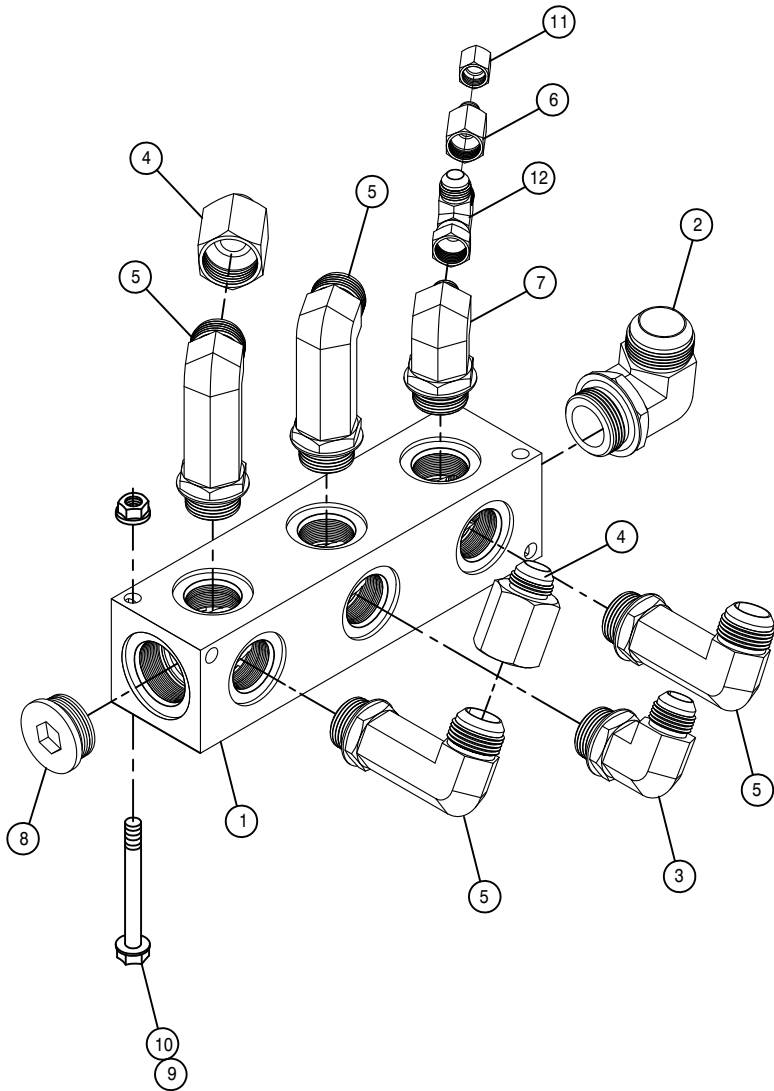

CASE DRAIN MANIFOLD ASSEMBLY

DET.	QTY	PART NO.	DESCRIPTION
1	1	606246	MANIFOLD, #16 3-STN 180
2	1	618477	1 5/8MJIC-90-1 5/8MOR LBO
3	1	618302	1 1/16MJIC-90-1 5/16MOR LBO
4	2	618541	1 5/16FJIC-1 1/16MJIC ADPTR
5	4	618463	1 5/16MJIC-90-1 5/16MOR XL LBO
6	1	618482	3/4FJIC-9/16MJIC ADPTR
7	1	618475	3/4MJIC-90-1 5/16MOR LBO
8	1	618759	1 5/8MOR PLUG, HEX SOCKET
9	2	470087	3/8UNC HEX FLANGE LOCK NUT
10	2	900139	3/8UNC X 3 3/4 HEX BOLT
11	1	618531	9/16FJIC CAP NUT
12	1	618451	3/4FJIC SW RUN TEE-3/4MJIC

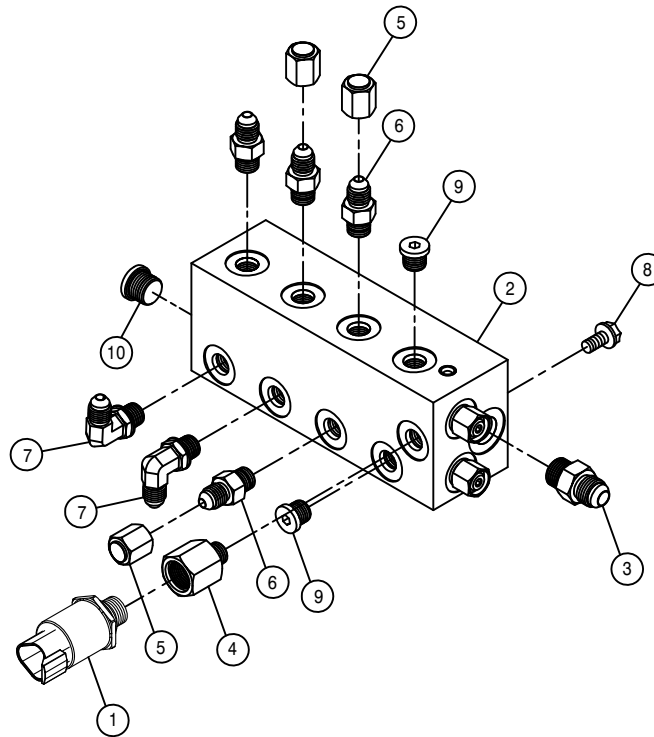

LS MANIFOLD ASSEMBLY

DET. QTY PART NO. DESCRIPTION

1	1	606347	PRESSURE TRANSDUCER, 7500PSI
2	1	606247	MANIFOLD W/CHK VLV SAUER
3	1	618126	9/16MJIC-9/16MOR ADPTR
4	1	618361	7/16MOR-9/16FOR ADPTR
5	3	618363	7/16FJIC CAP NUT
6	4	618467	7/16MJIC-7/16MOR ADPTR
7	2	618473	7/16MJIC-90-7/16MOR LBO
8	2	900128	3/8UNC X 3/4 HEX BOLT
9	2	618753	7/16MOR PLUG, HEX SOCKET
10	1	618754	9/16MOR PLUG, HEX SOCKET

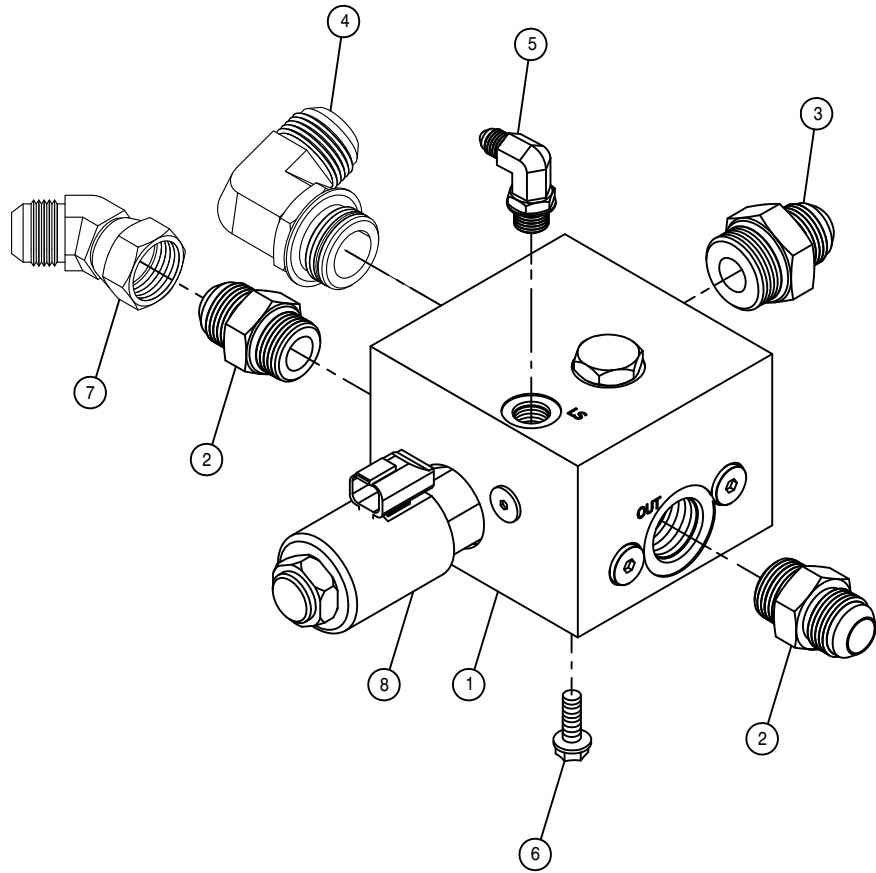

SOLUTION PUMP CONTROL VALVE ASSEMBLY

DET. QTY PART NO. DESCRIPTION

1	1	606253	CTRL VALVE,SOLU PUMP SAUER
2	2	611127	1 1/16MJC-1 1/16MOR ADPTR
3	1	618308	1 1/16MJC-1 5/16MOR ADPTR
4	1	618178	1 5/16MJC-90-1 5/16MOR LBO
5	1	618499	7/16MJC-90-9/16MOR LBO
6	4	900129	3/8UNC X 1" SERR FLANGE BOLT
7	1	618529	1 1/16MJ-45-1 1/16FJ SWIV LBO
8	1	606308	COIL FOR VLV 606253

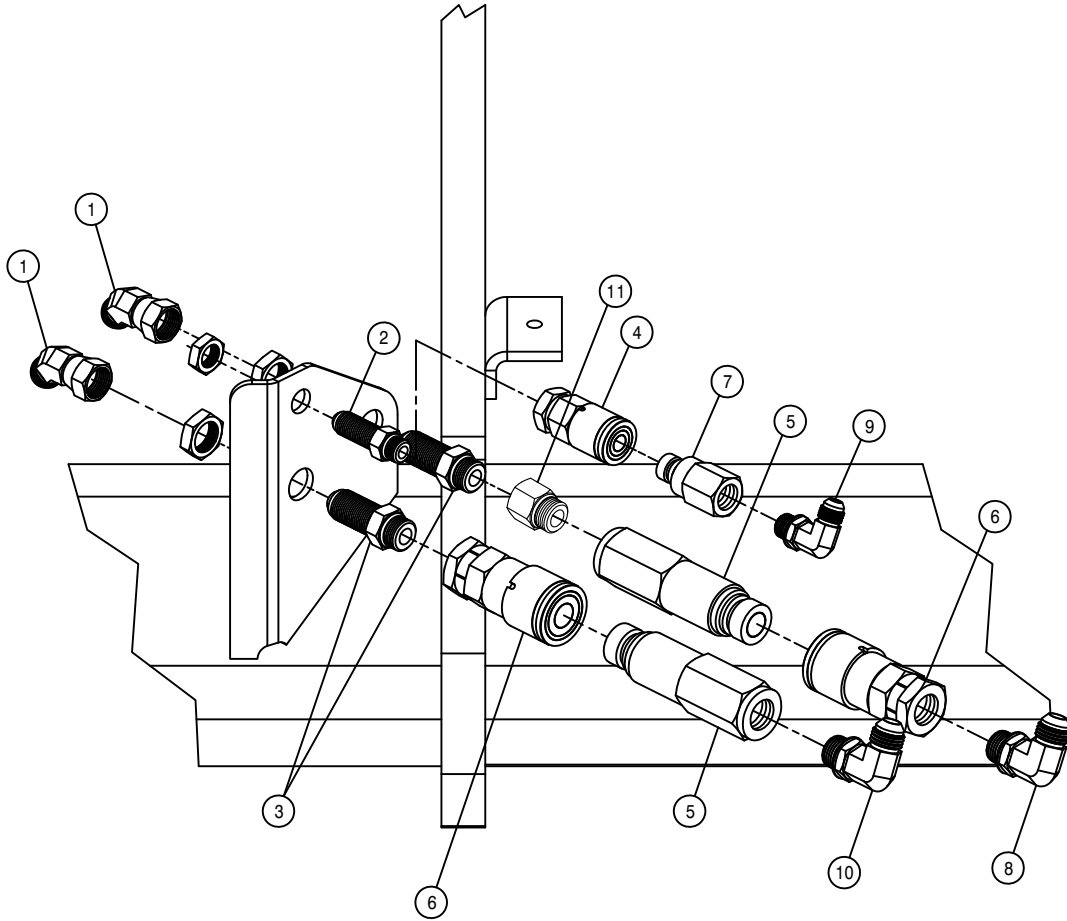

QUICK CONNECT ASSEMBLY

DET.	QTY	PART NO.	DESCRIPTION
1	2	618590	3/4MJIC-45-3/4FJIC SWIV LBO
2	1	618769	9/16MJIC-9/16MOR BLKHD ADPT
3	2	618770	3/4MJIC-3/4MOR BLKHD ADPT
4	1	618805	HYD CPLR, FEM #14,9/16FOR
5	2	618806	HYD CPLR, MALE #12,7/8FOR
6	2	618807	HYD CPLR, FEM #12,3/4FOR
7	1	618804	HYD CPLR, MALE #14,9/16FOR
8	1	618241	3/4MJIC-90-3/4MOR LBO
9	1	618119	9/16MJIC-90-9/16MOR LBO
10	1	618183	3/4MJIC-90-7/8MOR LBO
11	1	618171	7/8MOR-3/4FOR ADPTR

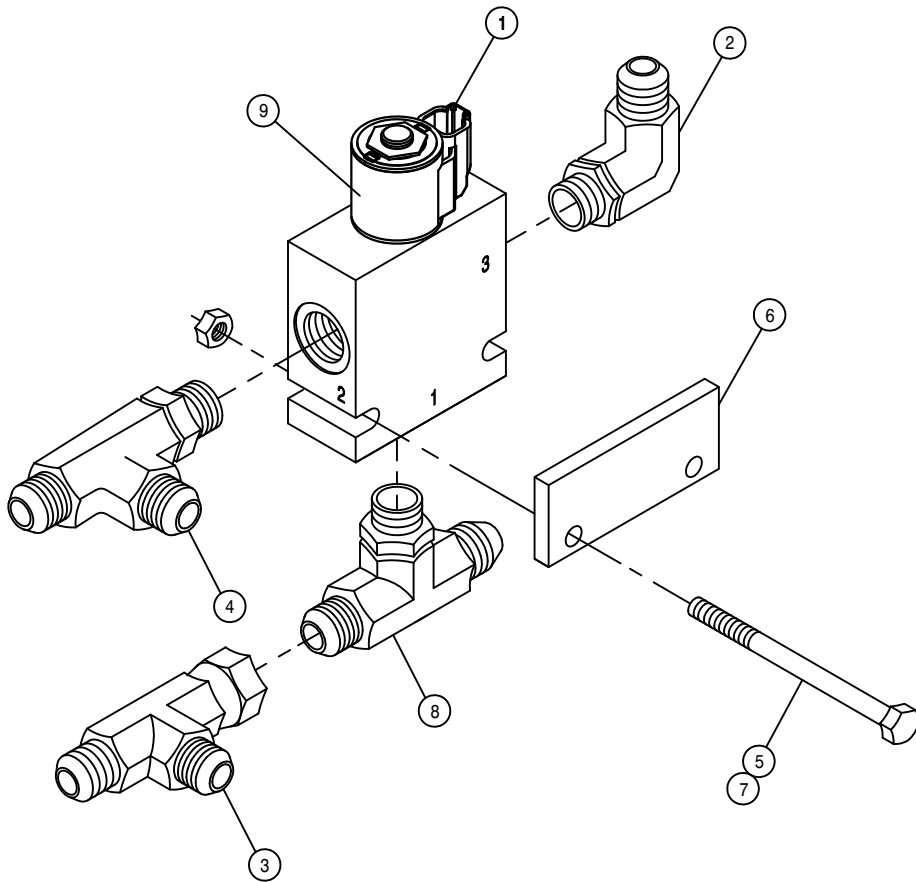

LADDER AND BRAKE ASSEMBLY

DET. QTY PART NO. DESCRIPTION

1	1	606213	HYD SOLE VLV,2P-3W,9/16FOR 05
2	1	618119	9/16MJIC-90-9/16MOR LBO
3	1	618486	9/16FJIC SW RUN TEE-9/16MJIC
4	1	618444	9/16MOR RUN TEE-9/16MJIC
5	2	900007	1/4UNC X 2" HEX BOLT
6	1	342826	SOLE VLV SPACER
7	2	914000	1/4UNC HEX STOVER NUT
8	1	618629	9/16MOR BRANCH TEE-9/16MJIC
9	1	606266	#8 COIL W/DEUTSCH FOR 606210

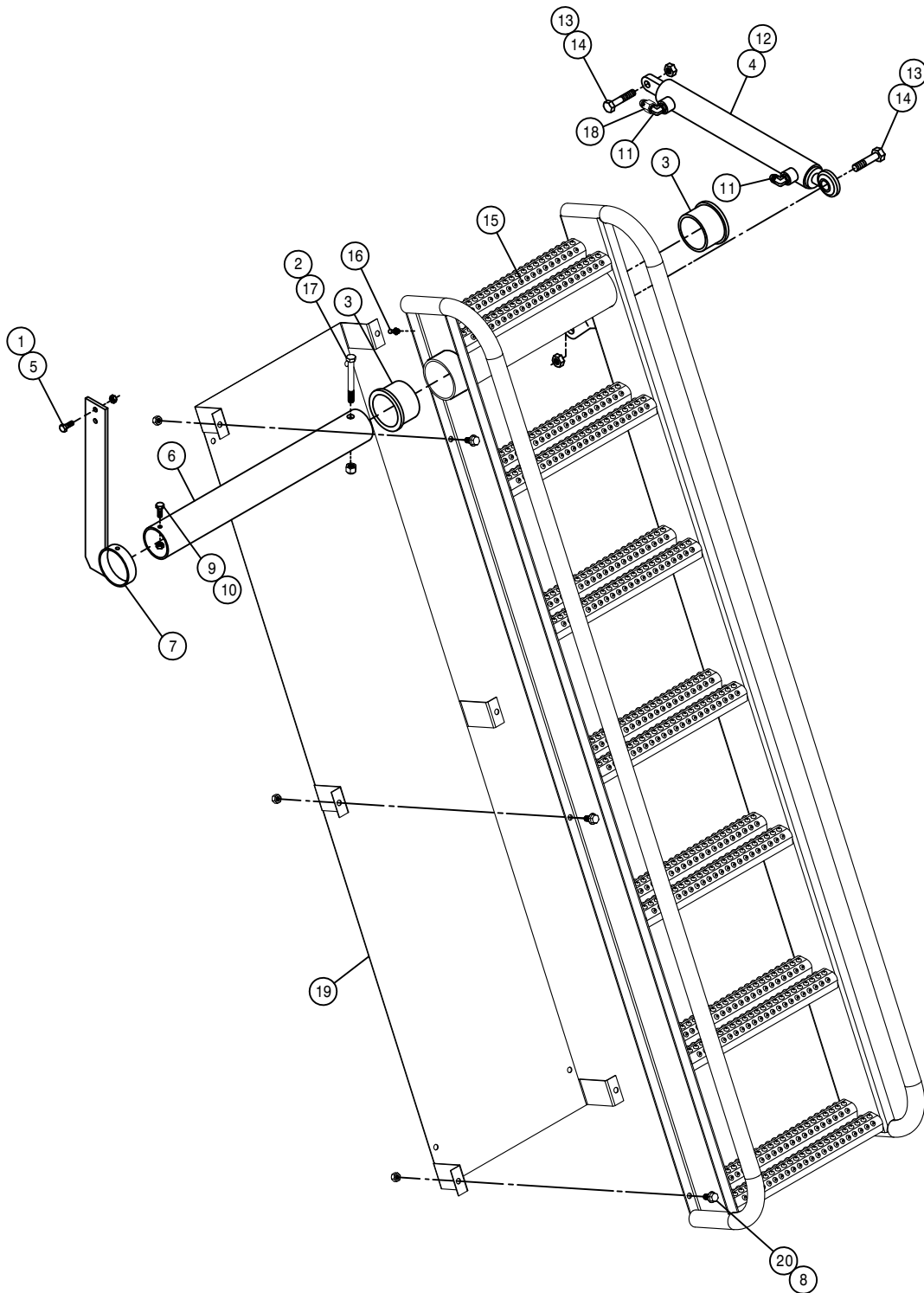

LADDER ASSEMBLY

DET.	QTY	PART NO.	DESCRIPTION
	1	2	914002 5/16UNC HEX STOVER NUT
	2	1	473007 1/2UNC HEX NUT, NYLOC
	3	2	121102 LADDER PIVOT BEARING POLYGON
	4	1	621554 HYD CYL, 1.50 X 12.25 X .750
	5	2	900065 5/16UNC X 1" HEX BOLT
	6	1	342805 LADDER MT TUBE
	7	1	342806 LH PLTFRM SUPP BRKT WLD, STS12
	8	6	914004 3/8UNC HEX STOVER NUT
	9	1	914000 1/4UNC HEX STOVER NUT
	10	1	900003 1/4UNC X 1" HEX BOLT
	11	2	618119 9/16MJIC-90-9/16MOR LBO
	12	1	621555 REPAIR KIT, HYD CYL 621554
	13	2	914008 1/2UNC HEX STOVER NUT
	14	2	900267 1/2UNC X 2" HEX BOLT
	15	1	343808 LADDER WLDMNT, STS10/16 '11
	16	1	471005 GREASE ZERK, 1/4-28 X 1/2
	17	1	900275 1/2UNC X 4 1/2 HEX BOLT
	18	1	618733 9/16JIC .042 ORIFICE ADPTR
	19	1	344009 STEP BACKPLATE, STS CE '11
	20	6	900128 3/8UNC X 3/4 HEX BOLT

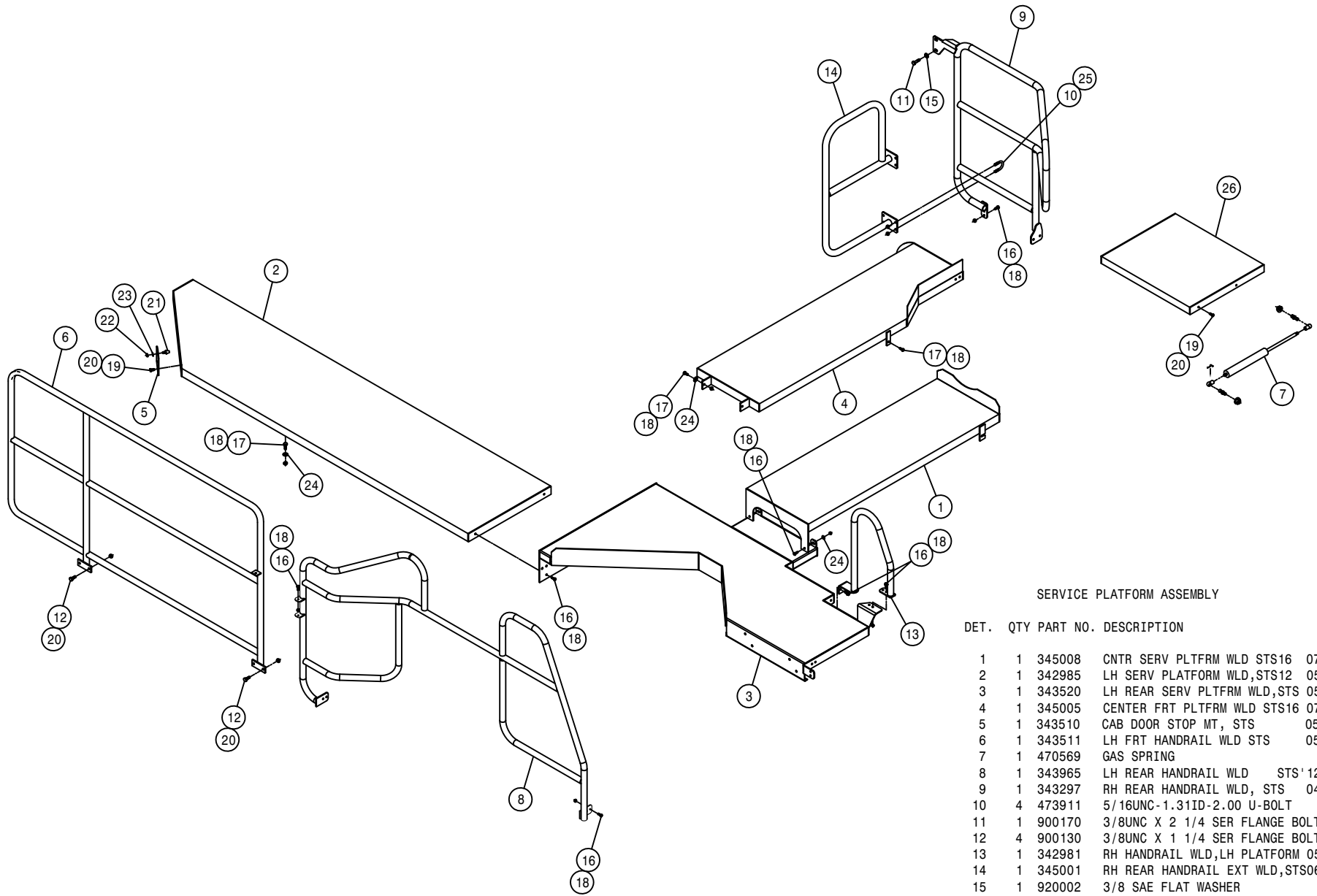

SERVICE PLATFORM ASSEMBLY

DET.	QTY	PART NO.	DESCRIPTION
1	1	345008	CNTR SERV PLTFRM WLD STS16 07
2	1	342985	LH SERV PLATFORM WLD,STS12 05
3	1	343520	LH REAR SERV PLTFRM WLD,STS 05
4	1	345005	CENTER FRT PLTFRM WLD STS16 07
5	1	343510	CAB DOOR STOP MT, STS 05
6	1	343511	LH FRT HANDRAIL WLD STS 05
7	1	470569	GAS SPRING
8	1	343965	LH REAR HANDRAIL WLD STS'12
9	1	343297	RH REAR HANDRAIL WLD, STS 04
10	4	473911	5/16UNC-1.31ID-2.00 U-BOLT
11	1	900170	3/8UNC X 2 1/4 SER FLANGE BOLT
12	4	900130	3/8UNC X 1 1/4 SER FLANGE BOLT
13	1	342981	RH HANDRAIL WLD,LH PLATFORM 05
14	1	345001	RH REAR HANDRAIL EXT WLD,STS06
15	1	920002	3/8 SAE FLAT WASHER
16	22	900064	5/16UNC X 3/4 HEX BOLT
17	9	900065	5/16UNC X 1" HEX BOLT
18	29	914002	5/16UNC HEX STOVER NUT
19	6	900129	3/8UNC X 1" SERR FLANGE BOLT
20	8	914004	3/8UNC HEX STOVER NUT
21	1	470571	BUMPER,MALE STUD 2.375 X 1.75
22	1	470087	3/8UNC HEX FLANGE LOCK NUT
23	1	920502	3/8 LOCK WASHER
24	12	920001	5/16 SAE FLAT WASHER
25	8	470113	5/16UNC HEX FLANGE LOCK NUT
26	1	343304	ENG CMPRTMNT PLTFRM WLD,STS 04

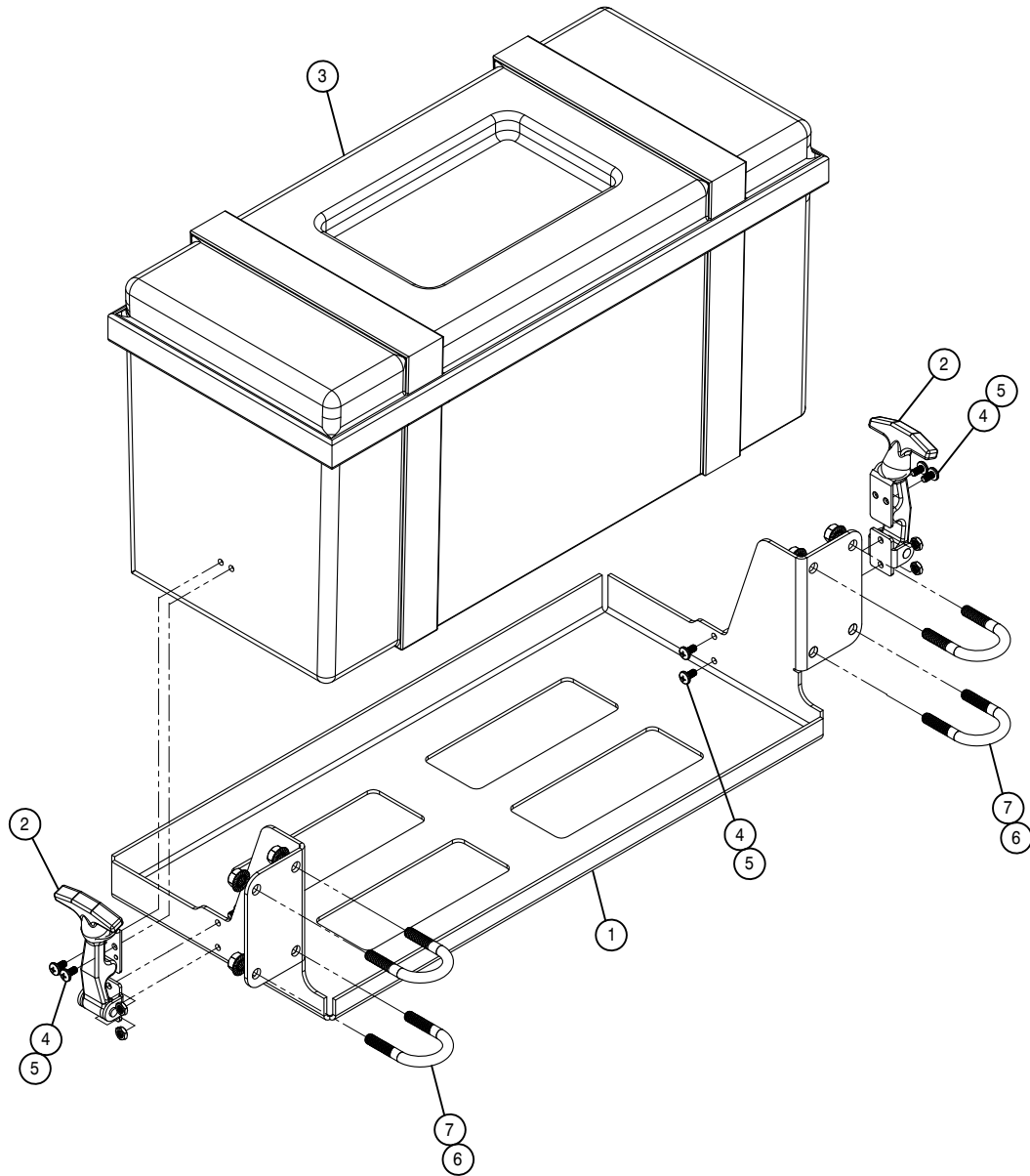

TOOLBOX ASSEMBLY

DET. QTY PART NO. DESCRIPTION

DET.	QTY	PART NO.	DESCRIPTION
1	1	345042	TOOLBOX MT BASE, STS '12
2	2	470643	RUBBER DRAW LATCH
3	1	470841	TOOLBOX
4	8	903884	10-32X3/8 PHIL PANHD MACH SCR
5	8	914027	10-32 HEX STOVER NUT
6	8	470113	5/16UNC HEX FLANGE LOCK NUT
7	4	473911	5/16UNC-1.31ID-2.00 U-BOLT

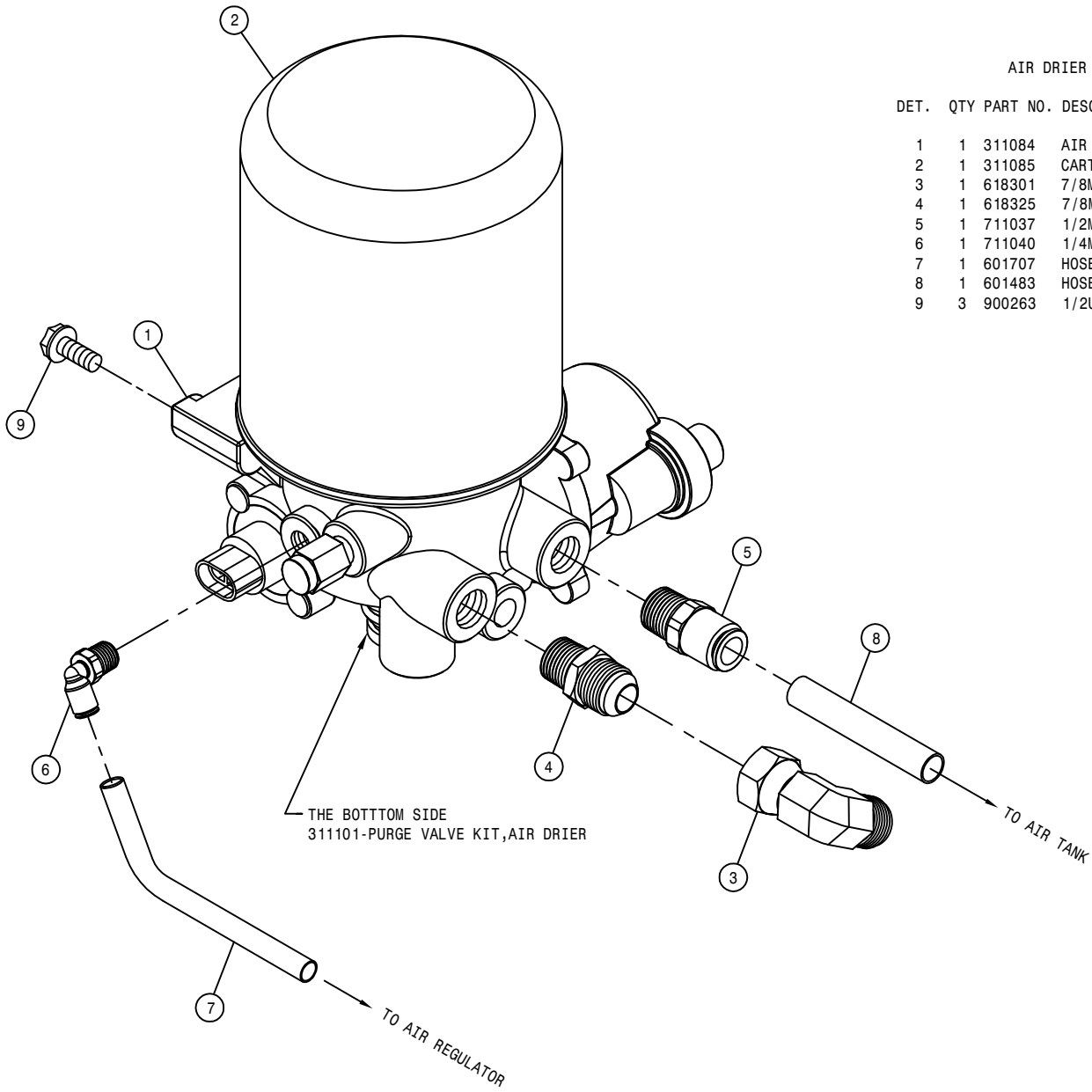

AIR DRIER ASSEMBLY

DET. QTY PART NO. DESCRIPTION

DET.	QTY	PART NO.	DESCRIPTION
1	1	311084	AIR DRIER,SYSTEM SAVER 1200
2	1	311085	CARTRIDGE KIT FOR 311084 DRIER
3	1	618301	7/8MJIC-90-7/8FJIC SWIV LBO
4	1	618325	7/8MJIC-1/2MNPT ADPTR
5	1	711037	1/2MNPT-1/2 NYL TUBE FTG
6	1	711040	1/4MNPT-90-1/4 NYL TUBE LBO
7	1	601707	HOSE, 1/4 X 63 AIR
8	1	601483	HOSE, 1/2 X 84 AIR
9	3	900263	1/2UNC X 1" HEX BOLT

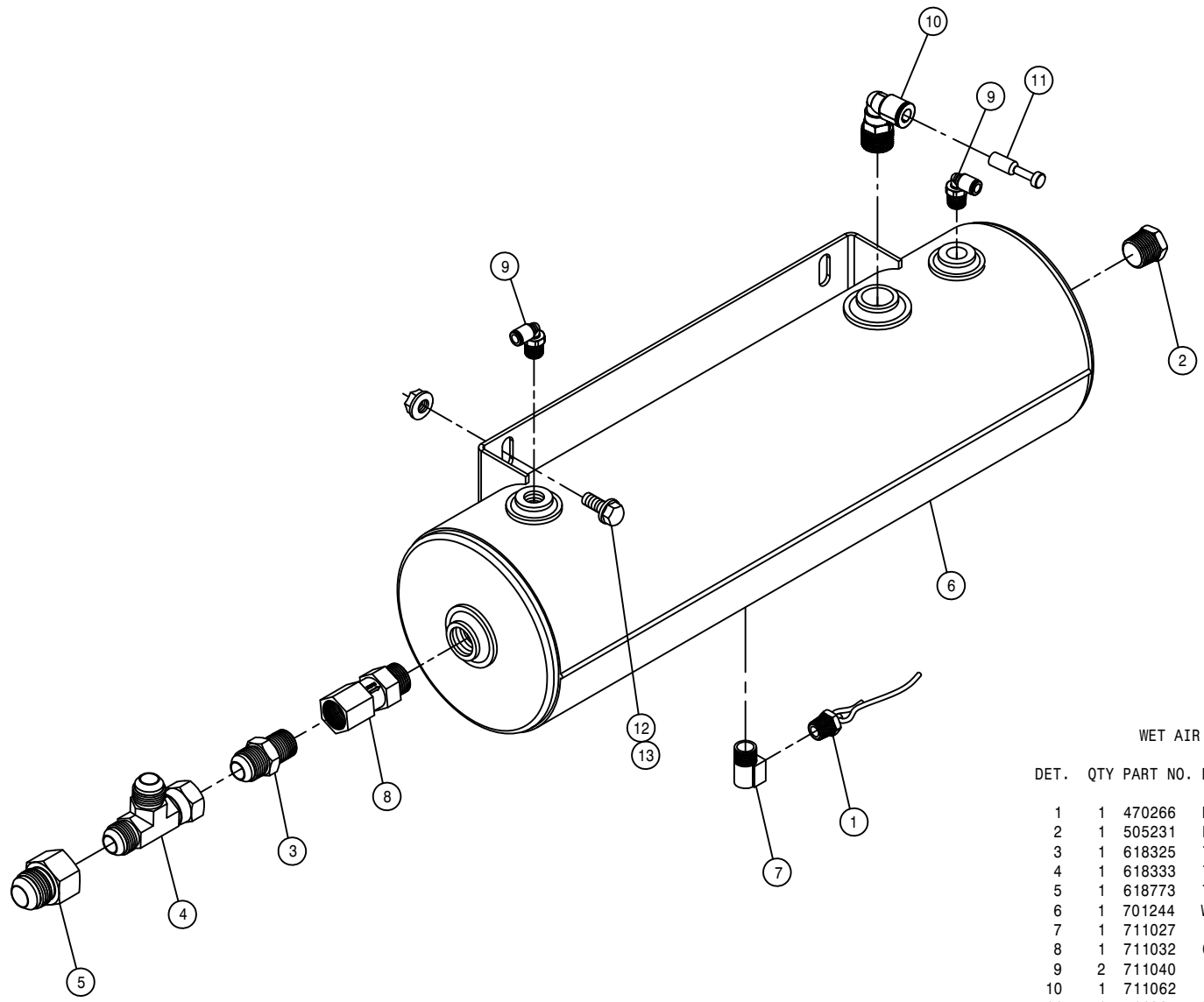

WET AIR TANK ASSEMBLY

DET. QTY PART NO. DESCRIPTION

1	1	470266	DRAIN VALVE KIT, 1/4NPT
2	1	505231	PIPE PLUG .50NPT HEX HD BRS
3	1	618325	7/8MJIC-1/2MNPT ADPTR
4	1	618333	7/8FJIC SW RUN TEE-7/8MJIC
5	1	618773	7/8FJIC-1 1/16MJIC ADPTR
6	1	701244	WET AIR TANK STSLS 16 06
7	1	711027	1/4 NPT ST EL BRS
8	1	711032	CHECK VALVE, 1/2"FNPT-1/2"MNPT
9	2	711040	1/4MNPT-90-1/4 NYL TUBE LBO
10	1	711062	1/2MNPT-90-3/8 NYL 1-TUBE LBO
11	1	711064	RUBBER PLUG FOR 3/8 PISCO CPLR
12	2	900128	3/8UNC X 3/4 HEX BOLT
13	2	470087	3/8UNC HEX FLANGE LOCK NUT

AIR TANK ASSEMBLY

DET. QTY PART NO. DESCRIPTION

1	1	470266	DRAIN VALVE KIT, 1/4NPT
2	1	505228	RED BUSH 3/4MNPT-1/2FNPT, BRS
3	1	505232	RED BUSH 3/4MNPT-1/4FNPT, BRS
4	1	505230	3/4 NPT ST EL BRS
5	1	701154	AIR TANK
6	2	711027	1/4 NPT ST EL BRS
7	1	711037	1/2MNPT-1/2 NYL TUBE FTG
8	1	711045	3/8MNPT-90-1/4 NYL 2-TUBE LBO
9	1	711046	3/8MNPT-90-1/4 NYL 3-TUBE LBO
10	1	311086	CHECK VALVE, PRESS CTRL, WABCO
11	1	601476	HOSE, 1/4 X 120 AIR
12	1	601478	HOSE, 1/4 X 175 AIR
13	1	601592	HOSE, 1/4 X 69 AIR
14	1	601479	HOSE, 1/4 X 196 AIR
15	1	601480	HOSE, 1/4 X 230 AIR
16	1	601483	HOSE, 1/2 X 84 AIR
17	8	920002	3/8 SAE FLAT WASHER
18	4	900130	3/8UNC X 1 1/4 SER FLANGE BOLT
19	4	914004	3/8UNC HEX STOVER NUT
20	1	311081	PROTECTION VALVE, JACOBS
21	1	502707	PIPE NIPPLE,1/4NPT HEX, BRS
22	1	711049	1/4 NYL TUBE-1/4MNPT FTG
23	1	601671	HOSE, 1/4 X 145 AIR
24	1	711047	3/8MNPT-1/4NYL TUBE, DBL BRANCH
25	1	601394	HOSE, 1/4 X 34 AIR

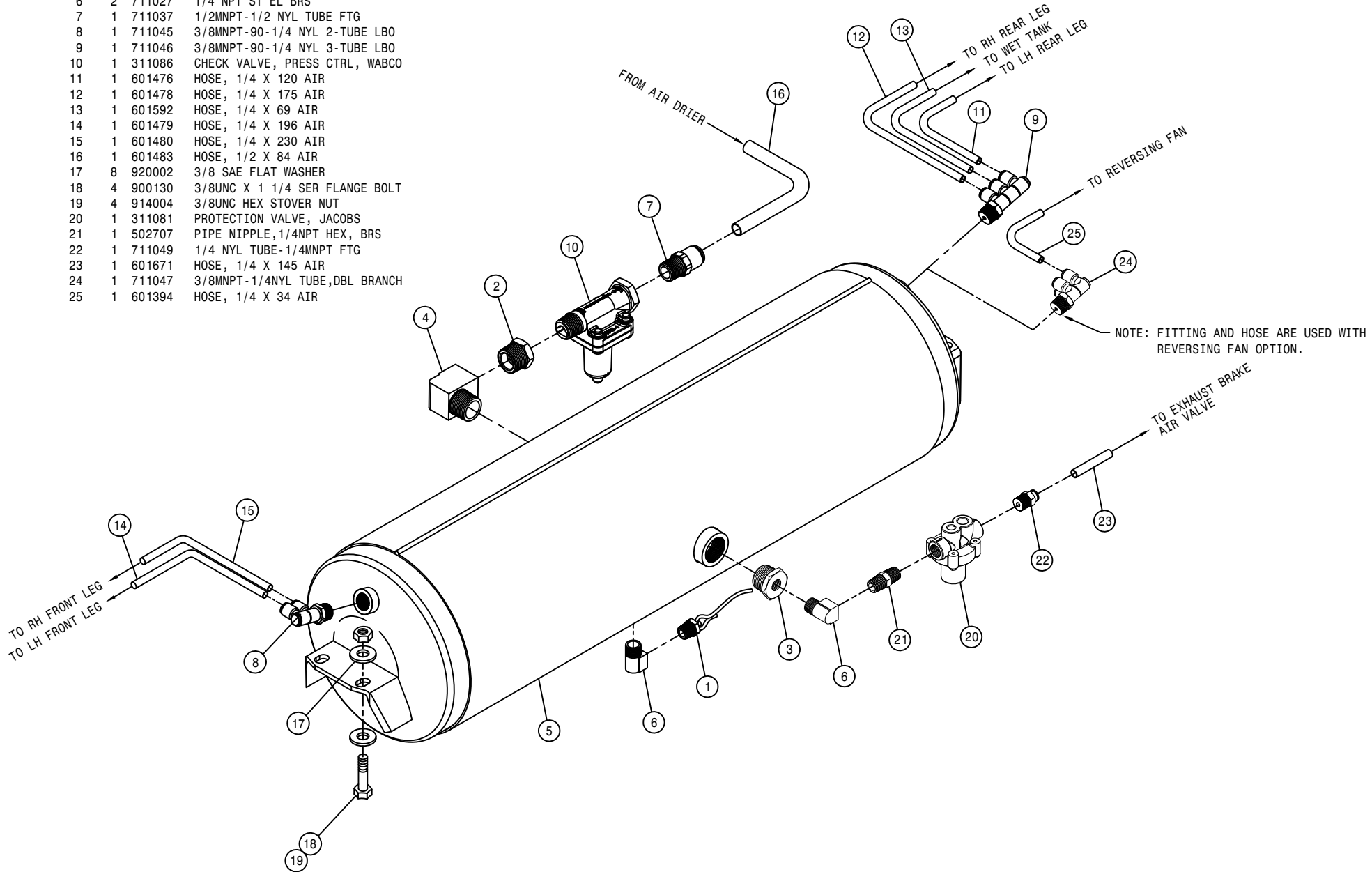

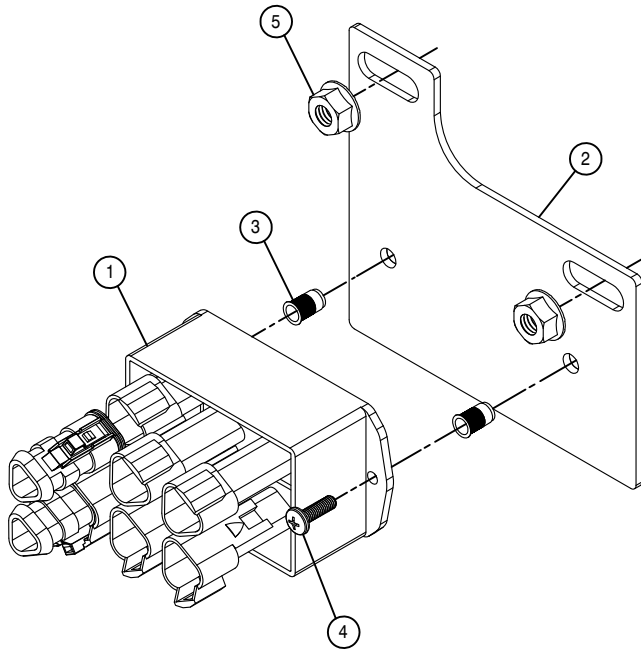

J1939 JUNCTION MODULE ASSEMBLY

DET. QTY PART NO. DESCRIPTION

1	1	292406	DATA LINK MODULE 99-6DLM
2	1	343697	J1939 MOUNTING BRKT STS' 12
3	2	470384	10-32 NUTSERT .020-.130 STL
4	2	903710	10-32X5/8 PHIL PANHD MACH SCR
5	2	470087	3/8UNC HEX FLANGE LOCK NUT

CAB ASSEMBLY (FRONT VIEW)

DET. QTY PART NO. DESCRIPTION

1	1	291749	TERM BLOCK, BLACK, 3/8-16 THRU
2	1	291750	TERM BLOCK, RED, 3/8-16 THRU
3	2	291900	RH WORKLIGHT, FLOOD GLASS
4	2	291901	LH WORKLIGHT, FLOOD GLASS
5	1	291902	RH WORKLIGHT, TRAPEZOID GLASS
6	1	291903	LH WORKLIGHT, TRAPEZOID GLASS
7	1	343431	STRG COLUMN ELECT PANEL, STS 05
8	1	343665	AUX ACCESS COVER, 2-PORT STS 08
9	1	343433	AUX ACCESS COVER, STS 05
10	1	343552	CAPLUG, 2X3 W/.75 HOLE, STS 05
11	1	343553	CAPLUG, 2X3 W/1.31 HOLE, STS 05
12	1	343855	CAB WLD STS' 12
13	5	470087	3/8UNC HEX FLANGE LOCK NUT
14	1	470118	1/4UNC X 3/4 FLANGE HEX BOLT
15	12	470122	1/4UNC X 1/2 FLANGE HEX BOLT
16	4	470234	5/16UNC X 1" FLANGE HEX BOLT
17	12	470380	1/4-20 NUTSERT .027-.165 STL
18	4	470381	5/16-18 NUTSERT .027-.150 STL
19	2	470393	KNOB, 3-BLADE BLK, 5/16-18X1 1/2
20	1	470397	RES-Q-ME TOOL
21	1	470398	BEAD CHAIN, #10 X 4" LONG
22	1	470400	BEAD CHAIN CONNECTOR #10 WHITE
23	1	470426	MOTOR, WINDSHIELD WIPER, STS 05
24	1	470427	BLADE, WINDSHIELD WIPER, STS 05
25	1	470428	ARM, WNDSHLD WIPER BLADE, STS 05
26	1	470429	SPRAY JET, WNDSHLD WIPER, STS 05
27	1	470503	SLAVE SHAFT, WINDSHIELD WIPER
28	1	470504	PIVOT SHAFT, 2.337 BALL STUD
29	22	470463	8-32 SERR. FLANGE NUT
30	6	470465	#12 X 3/4 PHIL PAN SHT MTL SCR
31	4	472238	12-24 X 1/2 PHIL PAN HD SCR
32	6	483019	7/8" INTERNAL TOOTH LOCK WASHER
33	2	483020	5/8" INTERNAL TOOTH LOCK WASHER
34	4	520080	HOSE CLAMP NO 10 STAINLESS
35	1	601678	HOSE, 5/8 X 8 HEATER
36	1	601679	HOSE, 5/8 X 13 HEATER
37	2	618497	7/8MJIC-7/8MJIC BLKHD UNION
38	2	629762	CAPPLUGS PLUG, 5/8" RD, BLK POLY
39	2	711101	5/8 HOSE BARB-7/8FJX ADPTR, BRS
40	4	903706	10-32X1 1/2 PHIL PAN MACH SCR
41	4	920510	#10 LOCK WASHER
42	4	910027	10-32 HEX NUT
43	22	903844	8-32 X 1/2 PHIL PANHD MACH SCR
44	1	657475	A/C HOSE ASSY, 5/16X12.50 BLKHD
45	1	657476	A/C HOSE ASSY, 1/2X12.50 BLKHD
46	1	657500	A/C & HEATER BLOWER SYS, STS 07
47	1	290062	HORN, FREEWAY BLASTER 130 DB
48	1	470121	1/4UNC HEX FLANGE LOCK NUT
49	2	470113	5/16UNC HEX FLANGE LOCK NUT
50	2	470233	5/16UNC X 3/4 FLANGE HEX BOLT
51	2	920502	3/8 LOCK WASHER
52	1	290059	BEACON, 12V AMBER HALOGEN
53	1	290060	BEACON TILT SURFACE MT, QK CHG

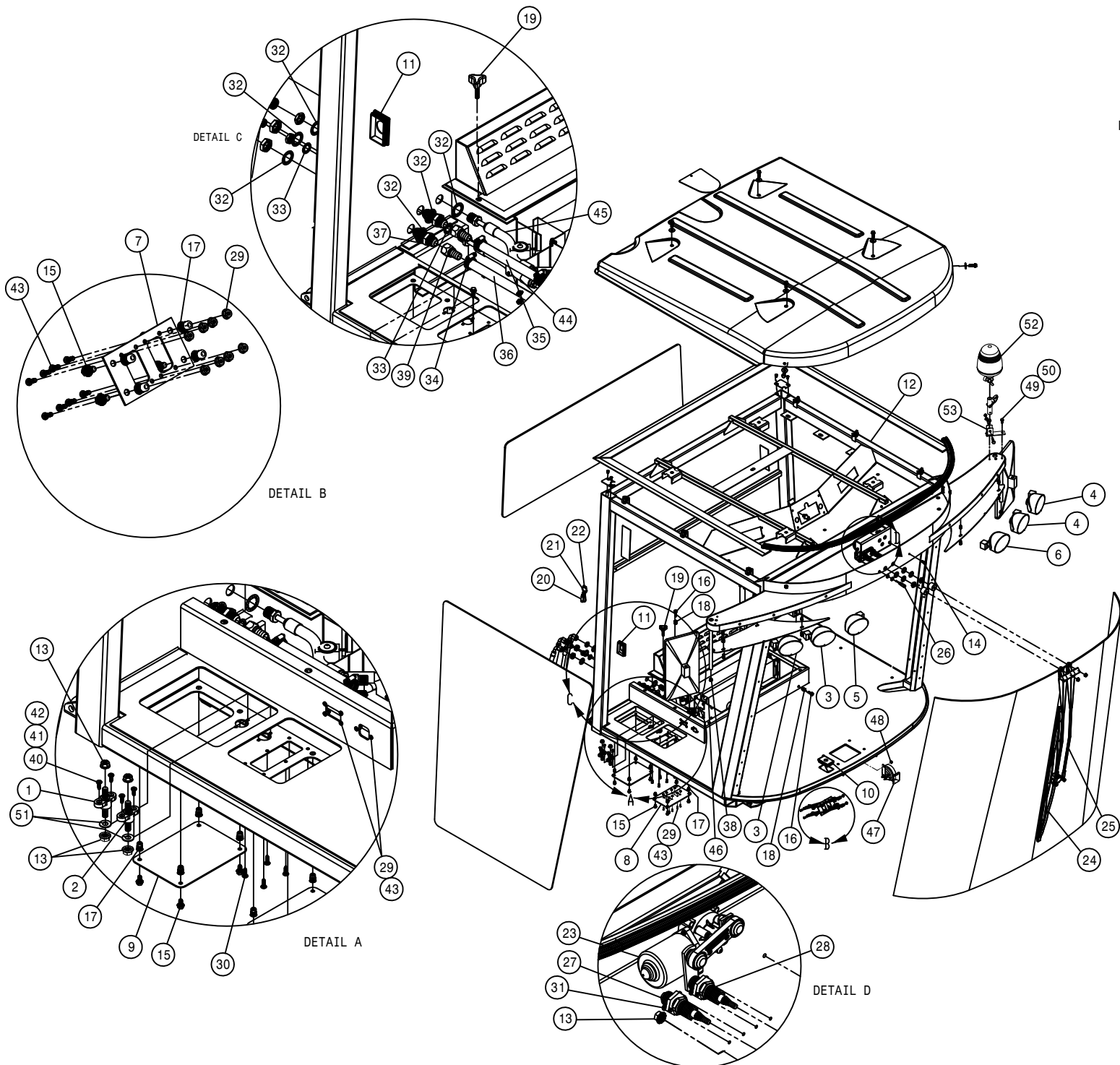

CAB ASSEMBLY (REAR VIEW)

DET. QTY PART NO. DESCRIPTION

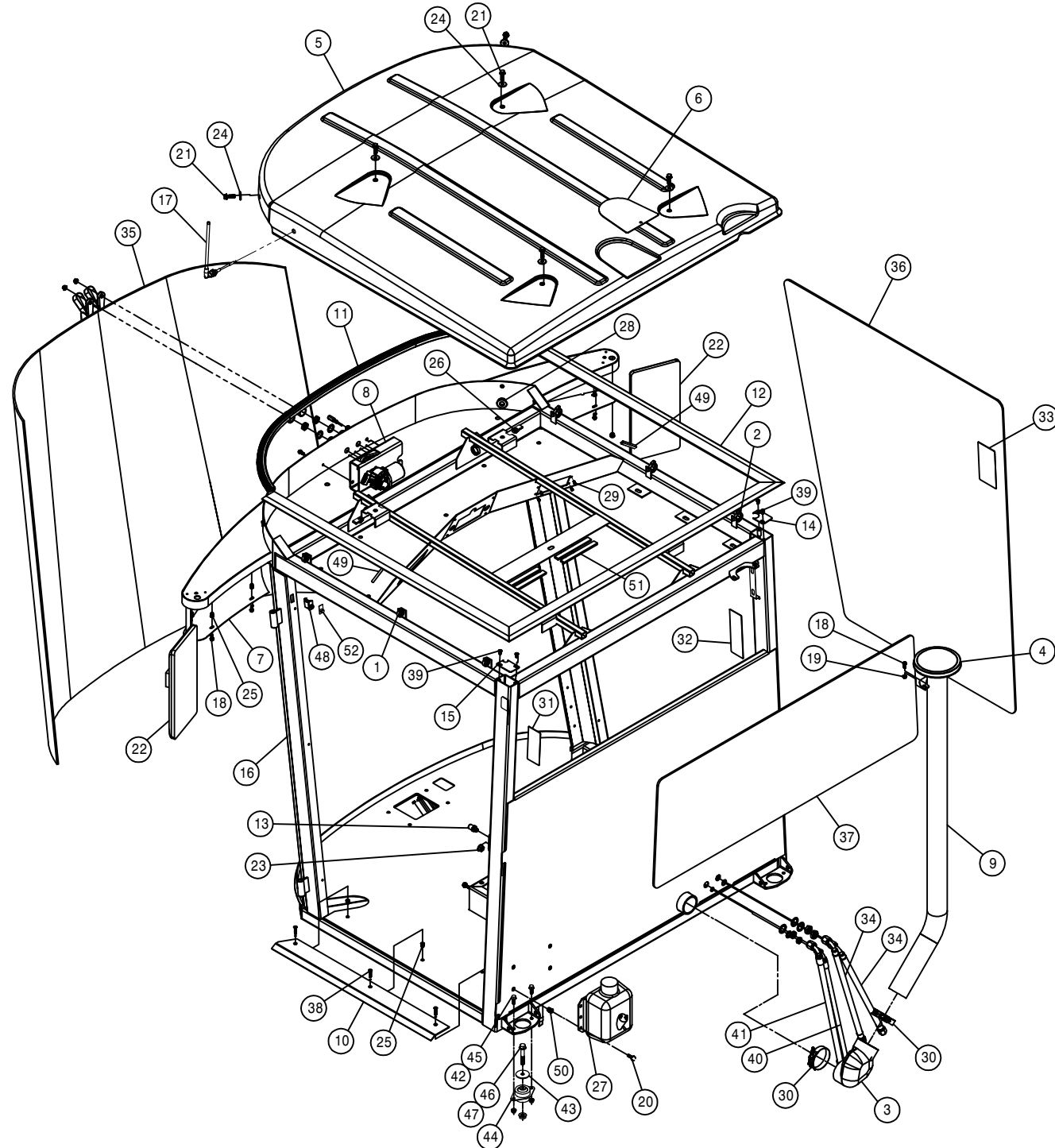

1	4	291009	ROSEBUD CLIP FOR .625 CONDUIT
2	4	291010	ROSEBUD CLIP FOR 1.000 CONDUIT
3	1	311533	3.00 90 DEG COBRA ELBOW RUBBER
4	1	311534	RAIN CAP, 3.00 PLASTIC
5	1	343824	CAB ROOF STS' 11
6	1	343351	GPS MTG PLATE, STS CAB 05
7	2	343352	LWR LIGHT MT COVER, STS CAB 05
8	1	343712	WIPER MTR MT WLD, STS CAB ' 10
9	1	343422	HVAC INTAKE TUBE WLD, STS CAB05
10	1	343434	CAB ENTRY STEP PLATE, STS 05
11	1	343582	FRT CAB ROOF SEAL, STS CAB 06
12	1	343583	CAB ROOF SEAL, STS CAB 06
13	1	470417	STRIKER PIN ASSY
14	1	343605	RH REAR CORNER POST CAP, STS 07
15	1	343606	LH REAR CORNER POST CAP, STS 07
16	1	343855	CAB WLD STS' 12
17	1	291214	ANTENNA
18	10	470118	1/4UNC X 3/4 HHSFB GR5 MC
19	2	470121	1/4UNC SER FLG LOCK NUT
20	4	470234	5/16UNC X 1" SER FLG HEX BOLT
21	6	470329	3/8UNC X1 1/4 SER FLG HEX BOLT
22	2	470348	MIRROR STS10 & STS12
23	1	473852	12MM-1.75 SERR FLANGE NUT, ZINC
24	6	470377	3/8 X 1 3/16 BONDED WASHER SS
25	11	910127	1/4-20 NUTSERT .027-.165YZ
26	4	470526	3/8UNC U-NUT, 1.125 CLIP ON
27	1	470440	WINDSHIELD WASHER TANK ASSY 05
28	2	470491	GROMMET, .75ID .125GW 1.25GD
29	4	910130	10-32 NUTSERT .020-.130 YZ
30	2	520130	3.31/3.59 T-BOLT HOSE CLAMP SS
31	1	650164	DECAL, NO PASSNGR, NOT NEAR LEAK
32	1	650165	DECAL, PWR LINE/BM FOLD/GLASS
33	1	650176	DECAL, CAUTION, CAB CHEM EXPOSUR
34	2	657479	10-213-10FJX-10FJX90-22 H/A
35	1	658035	WINDSHIELD, STS CAB 05
36	1	658036	RH CAB GLASS, STS 05
37	1	658038	REAR CAB GLASS, STS 05
38	3	900050	1/4UNC X 1 1/4 PH FLHD MAC SCR
39	4	903708	1/4UNCX1/2 PHL PNHD MCH SCR BZ
40	1	657477	A/C HOSE ASSY, 5/16 X 24"
41	1	657478	A/C HOSE, 10-10F-10F90-24
42	8	470087	3/8UNC HEX SER FLG NUT
43	4	311078	SNUBBING WASHER FOR 311077 05
44	4	311077	ISOLATION MOUNT, LF1.5 SER 05
45	8	470460	3/8UNC X 1 SER FLG BOLT
46	4	470461	1/2UNC X 3 SER FLG BOLT
47	4	470345	1/2UNC HEX SMTH FLG LOCK NUT
48	1	291915	SWITCH, PANEL MT PUSH BUTTON
49	2	193016	QUICKEDGE TRIM .060 TO .170
50	4	910128	5/16-18 NUTSERT .027-.150 YZ
51	4	193022	STICKERTITE 1/4 X 3/4
52	1	291964	SWITCH BOOT FOR 291915

HEADLINER ASSEMBLY

DET.	QTY	PART NO.	DESCRIPTION
1	8	470384	10-32 NUTSERT .020-.130 STL
2	2	473907	#10X5/8 OPHIL 8 SHT MTL SCR
3	1	291909	L.E.D. COURTESY LIGHT W/LEADS
4	1	291912	DOME LIGHT
5	1	291913	TRIM RING, DOME LIGHT 291912
6	2	291922	SPEAKERS,PAIR
7	8	472235	10-32 X 3/4 PHIL PAN MACH SCR
8	1	291932	RADIO, AM/FM/WB/CD
9	1	658344	HEADLINER, STS '11
10	1	292214	SWITCH, WASHER, STS
11	1	292215	SWITCH, WIPER, STS
12	2	292216	SWITCH,WORK/FIELD LIGHTS, STS
13	2	292261	MOUNTING TRIM,END VME
14	3	292262	MOUNTING TRIM, MIDDLE VMM
15	1	292270	SWITCH BLANK, VH2
16	19	483067	1/4 X 1.00 OD FENDER WASHER
17	1	343331	RADIO BEZEL,CAB, BLK PLASIC 05
18	4	473990	#8 X 3/4 PHIL PAN SHTMTL(A)SCR
19	1	343607	BEZEL,LIGHT/WIPER GST20 07
20	19	470457	1/4-20 WING NUT, NYLON
21	19	470456	1/4-20 X 1.00 STUD,SQ BASE,NYL
22	1	166855	BM SCT IND LIGHT WLD, 120'C'11
23	9	291740	RED LED IND LIGHT,12V 10MM
24	1	291741	GREEN LED IND LIGHT,12V 10MM
25	3	291742	YELLOW LED IND LIGHT,12V 10MM
26	1	470395	DIAL KNOB W/ARROW FOR .25 SHFT
27	1	650392	DECAL,BOOM 10 SCT IND LIGHT'11

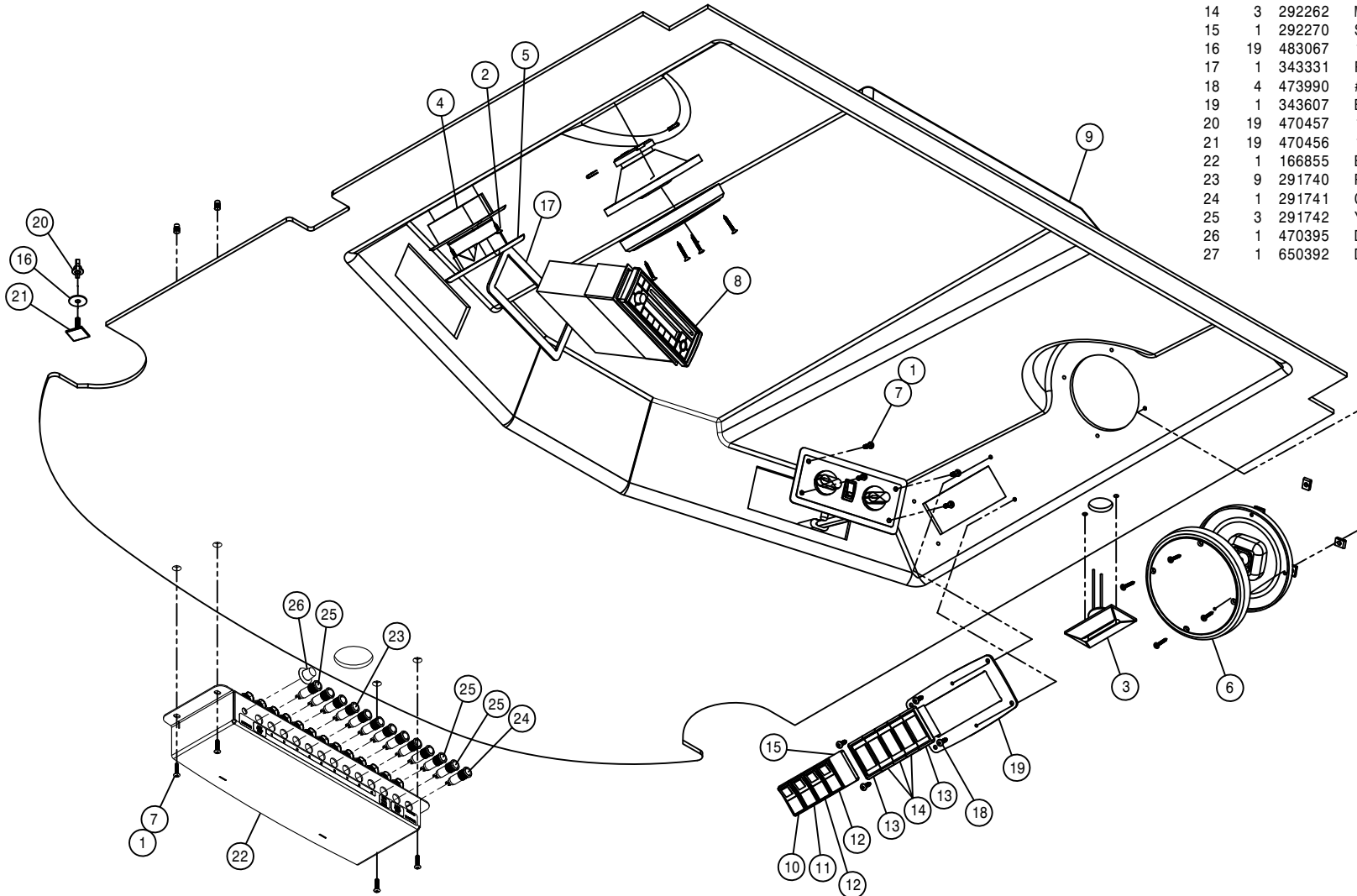

330103-TRIGGERING MECHANISM(CTRL KIT)
 330104-132146 SEAT AIR ADJ SWITCH
 330105-COMPRESSOR KIT

330050-HD SUSPENSION KIT, 12V,KNOEDLER
 330056-98 DUAL LOCK SLIDE KIT(LONG)
 330057-SEAT BELT KIT,RETRACTABLE
 330058-98 SEAT CUSHION,GREY W/OPS
 330059-9400 LH HEIGHT ADJ VALVE,ELECT
 330060-9400 LH LUMBAR VALVE,ELECT
 330061-LH ARMREST,GREY LEATHER GH725
 330062-98 HEADREST,GREY W/HAGIE LOGO
 330063-98 BACKREST,GREY W/O HEADREST
 330076-CHECK VALVE,KNOEDLER SEAT

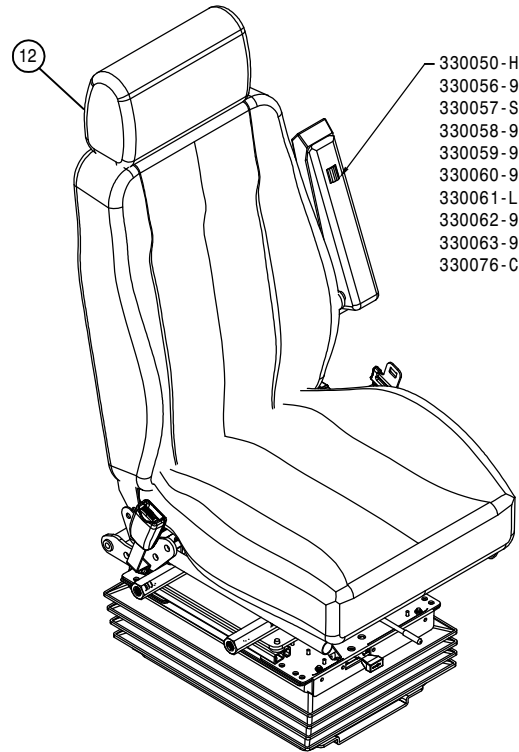
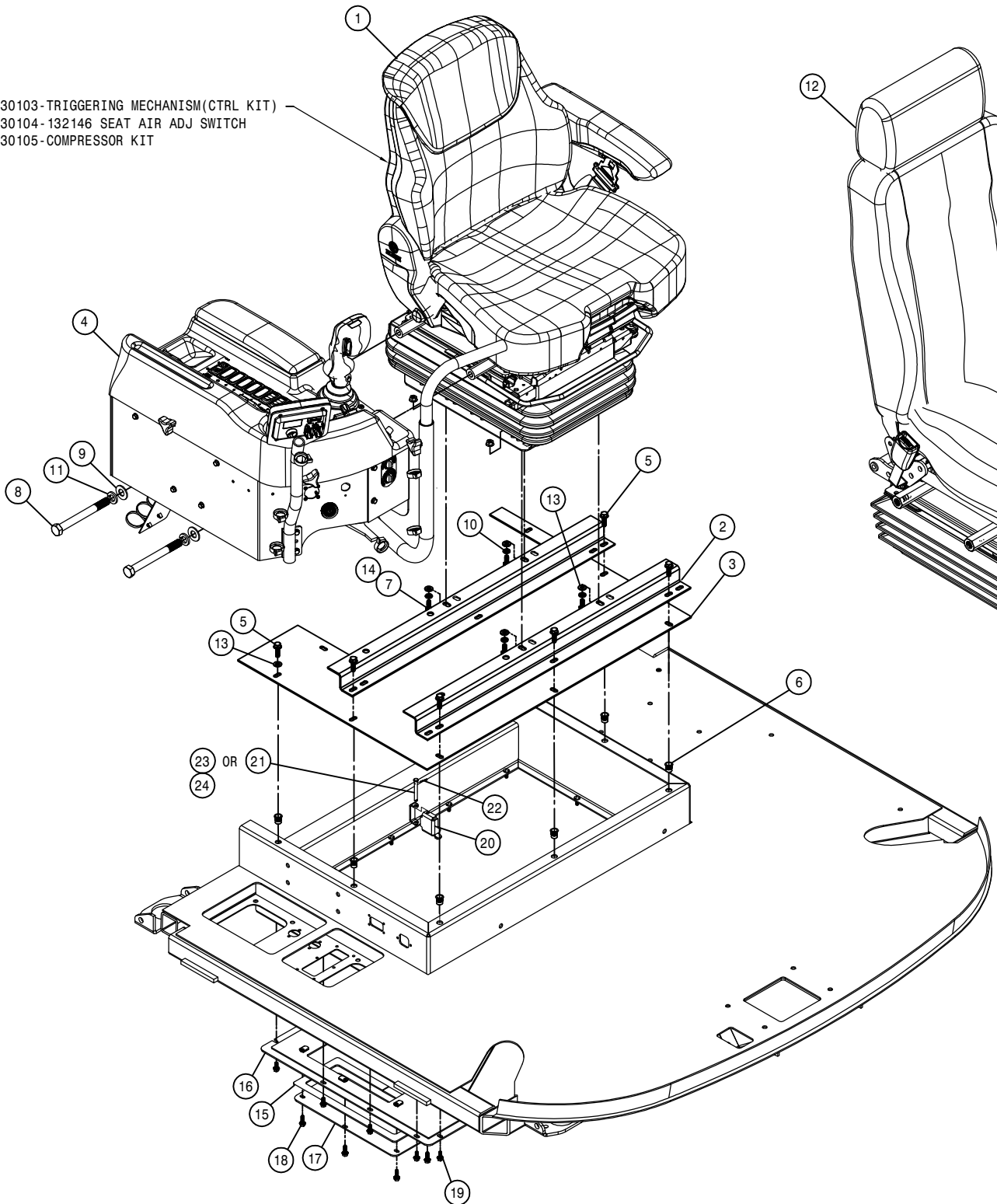

SEAT ASSEMBLY

DET. QTY PART NO. DESCRIPTION

1	1	330047	SEAT, STS GRAMMER	' 11
2	2	343429	SEAT BASE STIFF, STS CAB	05
3	1	343430	HVAC LID, STS CAB	STS' 05
4	1	343860	SIDE CONSOLE ASSY	STS' 12
5	8	470233	5/16UNC X 3/4 FLANGE HEX BOLT	
6	8	470381	5/16-18 NUTSERT .027-.150 STL	
7	4	473827	8MM-1.25 X 20MM HEX BOLT	
8	2	900346	5/8UNC X 6" HEX BOLT	
9	2	920005	5/8 SAE FLAT WASHER	
10	4	920501	5/16 LOCK WASHER	
11	2	920505	5/8 LOCK WASHER	
12	1	330048	SEAT, STS KNOEDLER	' 11
13	5	920001	5/16 SAE FLAT WASHER	
14	4	473858	8MM-1.25 SERR FLANGE NUT	
15	1	193037	STICKERTITE 1/8 X 3/4	
16	1	343841	LWR HVAC COVER WLD	STS' 12
17	1	343853	HVAC ACCESS COVER	STS' 12
18	6	470118	1/4UNC X 3/4 FLANGE HEX BOLT	
19	16	470122	1/4UNC X 1/2 FLANGE HEX BOLT	
20	1	343852	BRACKET	STS' 12
21	1	343854	HINGE PIN,CAB	STS' 12
22	1	470029	COTTER PIN 1/16 X 1/2	
23	1	900008	1/4UNC X 2 1/2 HEX BOLT	
24	1	914000	1/4UNC HEX STOVER NUT	

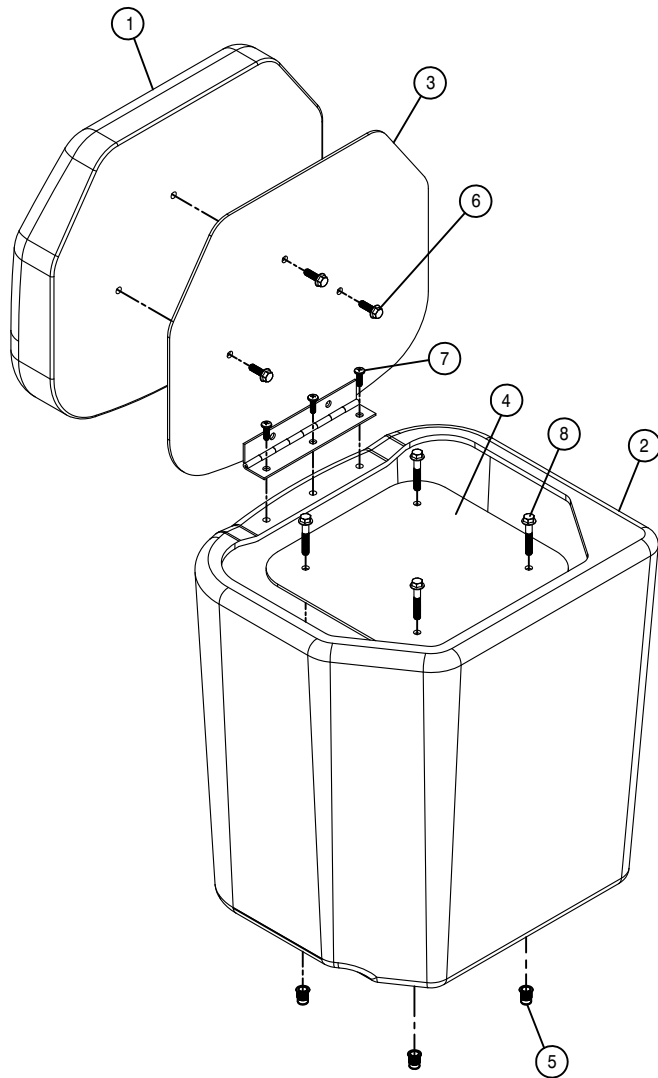

BUDDY SEAT ASSEMBLY

DET.	QTY	PART NO.	DESCRIPTION	
1	1	330036	BUDDY SEAT CUSHION	05
2	1	330037	BUDDY SEAT BASE, POLY	05
3	1	343425	BUDDY SEAT MT WLD, STS CAB	05
4	1	343428	BUDDY SEAT MT PANEL, STS CAB	05
5	4	470380	1/4-20 NUTSERT .027-.165	STL
6	3	470118	1/4UNC X 3/4 FLANGE HEX BOLT	
7	3	903710	10-32X5/8 PHIL PANHD MACH SCR	
8	4	900005	1/4UNC X 1 1/2 HEX BOLT	

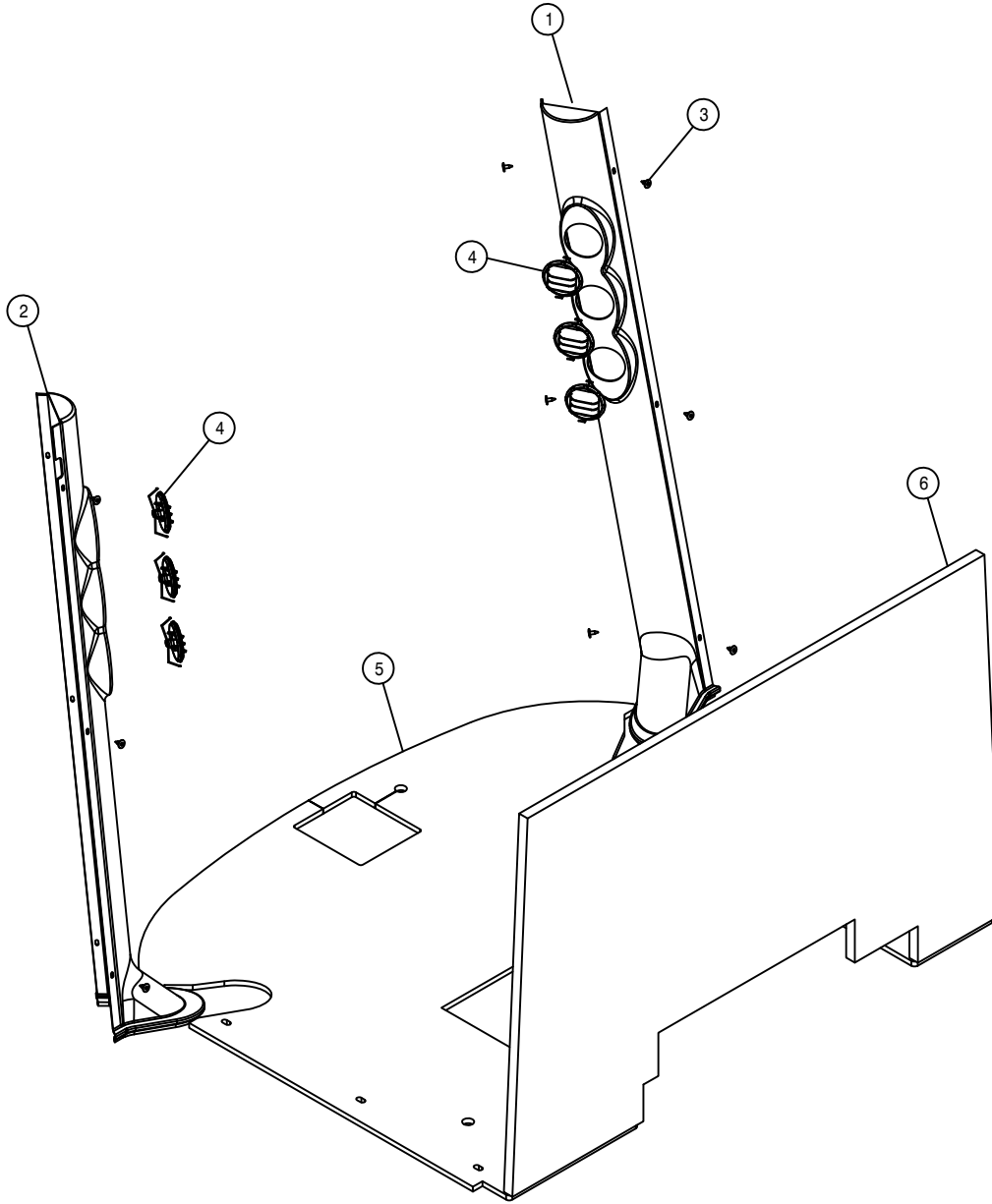

AIR DUCT AND FOAM ASSEMBLY

DET.	QTY	PART NO.	DESCRIPTION	
1	1	343356	RH AIR DUCT COVERS,STS CAB	05
2	1	343357	LH AIR DUCT COVERS,STS CAB	05
3	12	470466	1/4 X 3/4 PLTC LCK RIVET	
4	6	657469	LOUVER, ROUND	
5	1	658339	FLOOR MAT, STS CAB	'11
6	1	658333	FOAM, REAR CAB STS	05

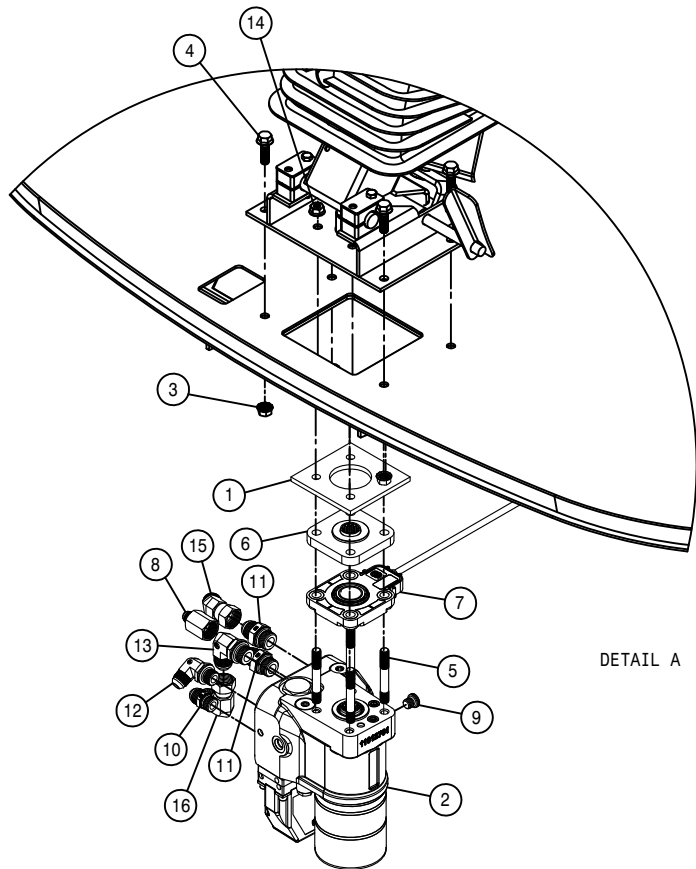

DETAIL A

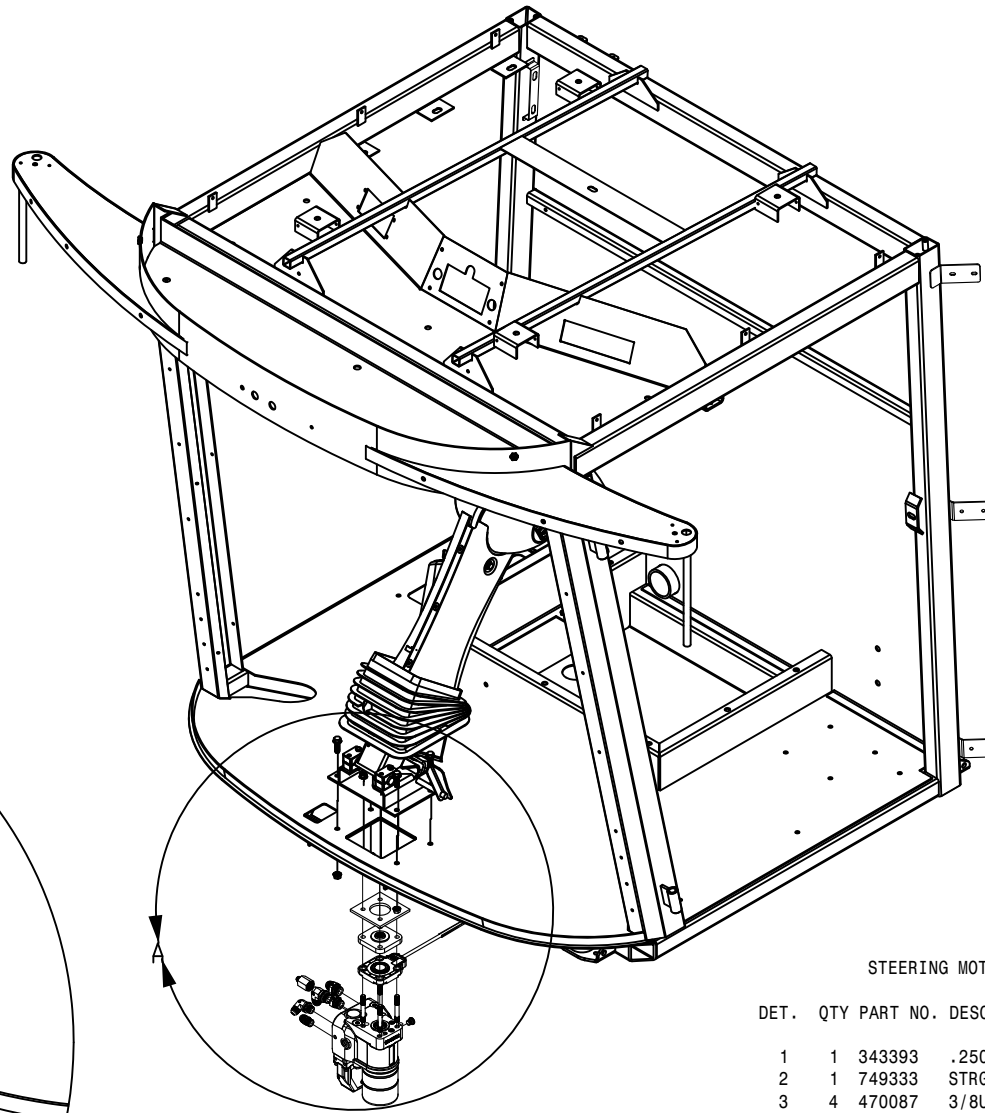

STEERING MOTOR ASSEMBLY

DET. QTY PART NO. DESCRIPTION

1	1	343393	.250 STRG MTR SPCR,CAB STS'12
2	1	749333	STRG CTRL VLV, OSPEDC 60/260
3	4	470087	3/8UNC HEX FLANGE LOCK NUT
4	4	470329	3/8UNC X 1 1/4 SER FLANGE BOLT
5	4	472340	M10-1.5 X 3" STUD BOLT,DBL END
6	1	749336	SAK SENSOR ADPTR KIT
7	1	749334	SASA SENSOR ASSY,STRG VLV '12
8	1	618557	7/8FJIC-9/16MJIC ADPTR
9	1	618909	M12 MOR PLUG, HEX SOCKET
10	1	618910	3/4MJIC-M18MOR ADPTR
11	2	618911	7/8MJIC-M22 MOR ADPTR
12	1	618912	3/4MJIC-90-M18MOR LBO
13	1	618913	7/8MJIC-90-M22MOR LBO
14	1	473866	10MM-1.50 SERR FLANGE NUT
15	1	618628	7/8MJIC-45-7/8FJIC SWIV LBO
16	1	618301	7/8MJIC-90-7/8FJIC SWIV LBO

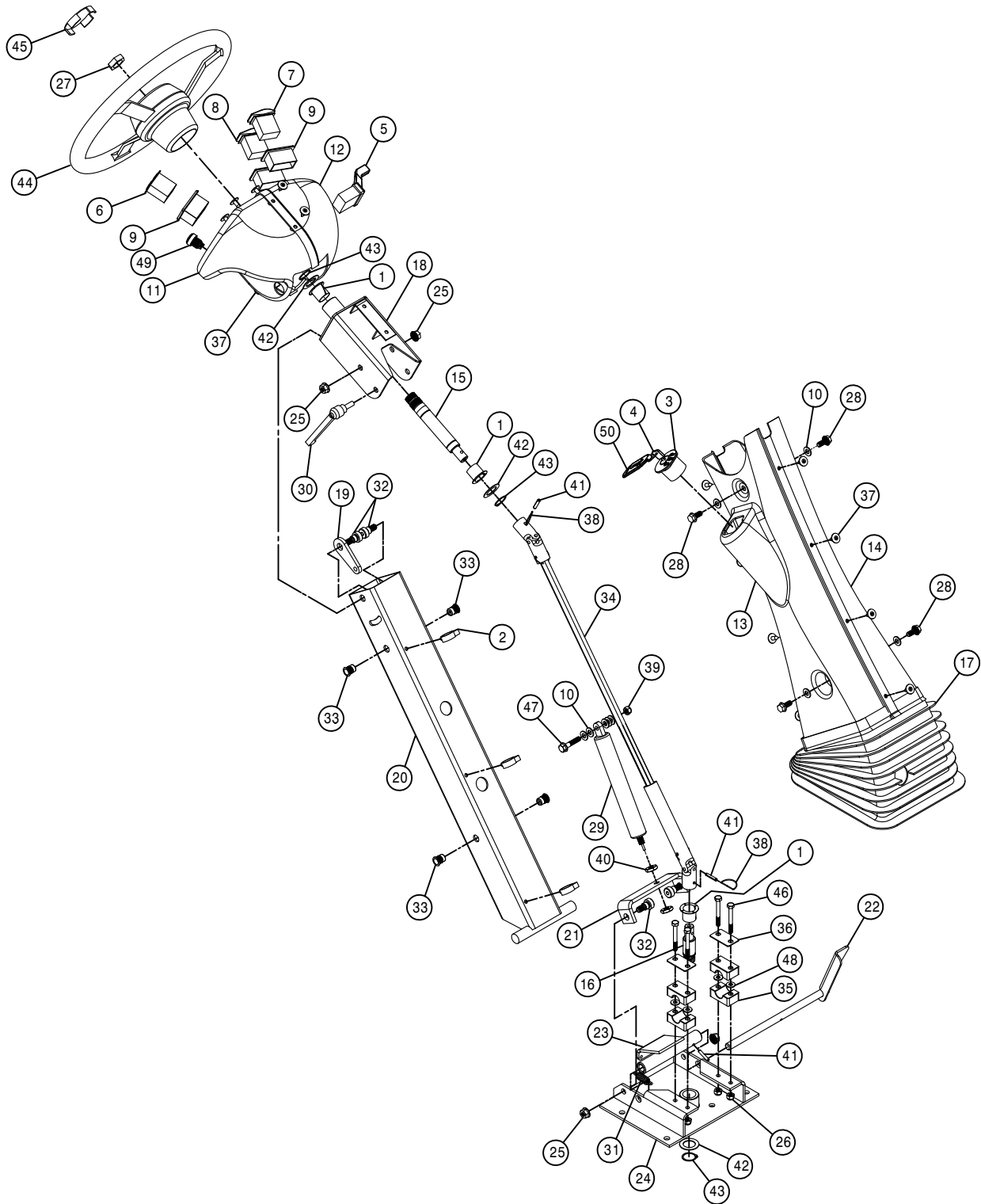

STEERING COLUMN ASSEMBLY

DET.	QTY	PART NO.	DESCRIPTION
	1	3	127503 NYLINER FLG BRG, .875 ID
	2	3	291006 ROSEBUD CLIP FOR .500 CONDUIT
	3	1	291916 IGNITION SWITCH W/KEY
	4	2	291917 IGNITION KEY FOR 291916
	5	1	292210 SWITCH, TURN SIGNAL, STS
	6	1	292211 TURN INDICATOR W/GREEN LED,STS
	7	1	292212 SWITCH,HAZARD,STS
	8	1	292213 SWITCH, HEADLIGHTS, STS
	9	3	292260 MOUNTING TRIM, SINGLE VMS
	10	9	920001 5/16 SAE FLAT WASHER
	11	1	343359 RH UPR STRG CLMN COVERS,STS 05
	12	1	343360 LH UPR STRG CLMN COVERS,STS 05
	13	1	343361 RH LWR STRG CLMN COVERS,STS 05
	14	1	343362 LH LWR STRG CLMN COVERS,STS 05
	15	1	343364 STRG SHAFT,UPPER COLUMN,STS 05
	16	1	343365 STRG SHAFT,LOWER COLUMN,STS 05
	17	1	343366 BELLOWS,STEERING COLUMN,STS 05
	18	1	343367 STEERING SUPP WELD, STS CAB 05
	19	1	343372 STRG COLUMN TOP LOCK, STS CAB
	20	1	343373 STEERING COLUMN WLD,STS CAB 05
	21	1	343385 GAS SHOCK PIVOT MT,STS CAB 05
	22	1	343386 TILT PEDAL WELD, STS CAB 05
	23	1	343389 TILT RELEASE WLD, STS CAB 05
	24	1	343614 STEERING BASE WELD,STS CAB 07
	25	4	910004N 3/8UNC FLANGE CNTR LOCK NUT
	26	4	470089 1/4UNC HEX NYLOC NUT, 316 SS
	27	1	470157 13/16-20UNEF HEX NUT STRG WHL
	28	4	470233 5/16UNC X 3/4 FLANGE HEX BOLT
	29	1	470252 GAS SPRING,3.15 STROKE LOCKING
	30	1	470257 ADJ HANDLE,3/8-16 STUD, BLACK
	31	1	470268 SPRING, EXTENSION, .50 X 1.75
	32	4	470283 3/8UNC 1/2 SCKT SHLDR BOLT
	33	4	470381 5/16-18 NUTSERT .027-.150 STL
	34	1	470401 DRIVE SHAFT ASSY, .625 U-JOINTS
	35	2	470405 CLAMP PAIR, 19MM SMOOTH BORE
	36	2	470406 TOP CLAMP, SIZE #3 FOR 470405
	37	16	470466 1/4 X 3/4 PLTC LCK RIVET
	38	4	470479 5"SAFETY LOCK WIRE,304SS .051D
	39	1	473001 5/16UNC HEX NUT,NYLOC 316 SS
	40	2	473830 10MM-1.00 HEX JAM NUT
	41	3	473928 ROLL PIN, 3/16 X 1
	42	3	483031 1 3/8 X 7/8 X 18GA MACH WASHER
	43	3	629533 SNAP RING, 7/8 EXTRN
	44	1	749294 STEERING WHEEL, VIP 14"
	45	1	749295 STRG WHL CAP WITH 'H' EMBLEM
	46	4	900023 1/4UNC X 2 1/4 HEX BOLT
	47	1	900067 5/16UNC X 1 1/2 HEX BOLT
	48	4	920022 1/4 FLAT WASH, AN960-416 SS
	49	1	292504 HORN SWITCH ASSY
	50	1	470544 HAGIE KEY CHAIN

CAB DOOR ASSEMBLY

DET.	QTY	PART NO.	DESCRIPTION
1	8	127502	NYLON FLANGE BRG
2	2	343332	CAB DOOR HINGE PIN,SS 05
3	2	473928	ROLL PIN, 3/16 X 1
4	2	470113	5/16UNC HEX FLANGE LOCK NUT
5	1	470253	HYD DAMPER,100LB,4"STROKE 1084
6	2	470254	BALL SOCKET, M6 THD X 10MM
7	2	470255	BALL STUD,5/16-18 THD X 10MM
8	2	470256	SAFTY CLIP, 10MM BALL SOCKET
9	8	127506	NYLON FLG BRG, STS '12
10	2	900348	1/2UNC X 6" HEX BOLT SS
11	2	473988	1/2UNC HEX NUT, NYLOC SS

NOTE: ITEMS MARKED WITH A (*) ARE A MID YEAR CHANGE.

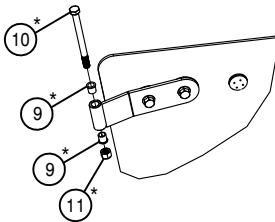
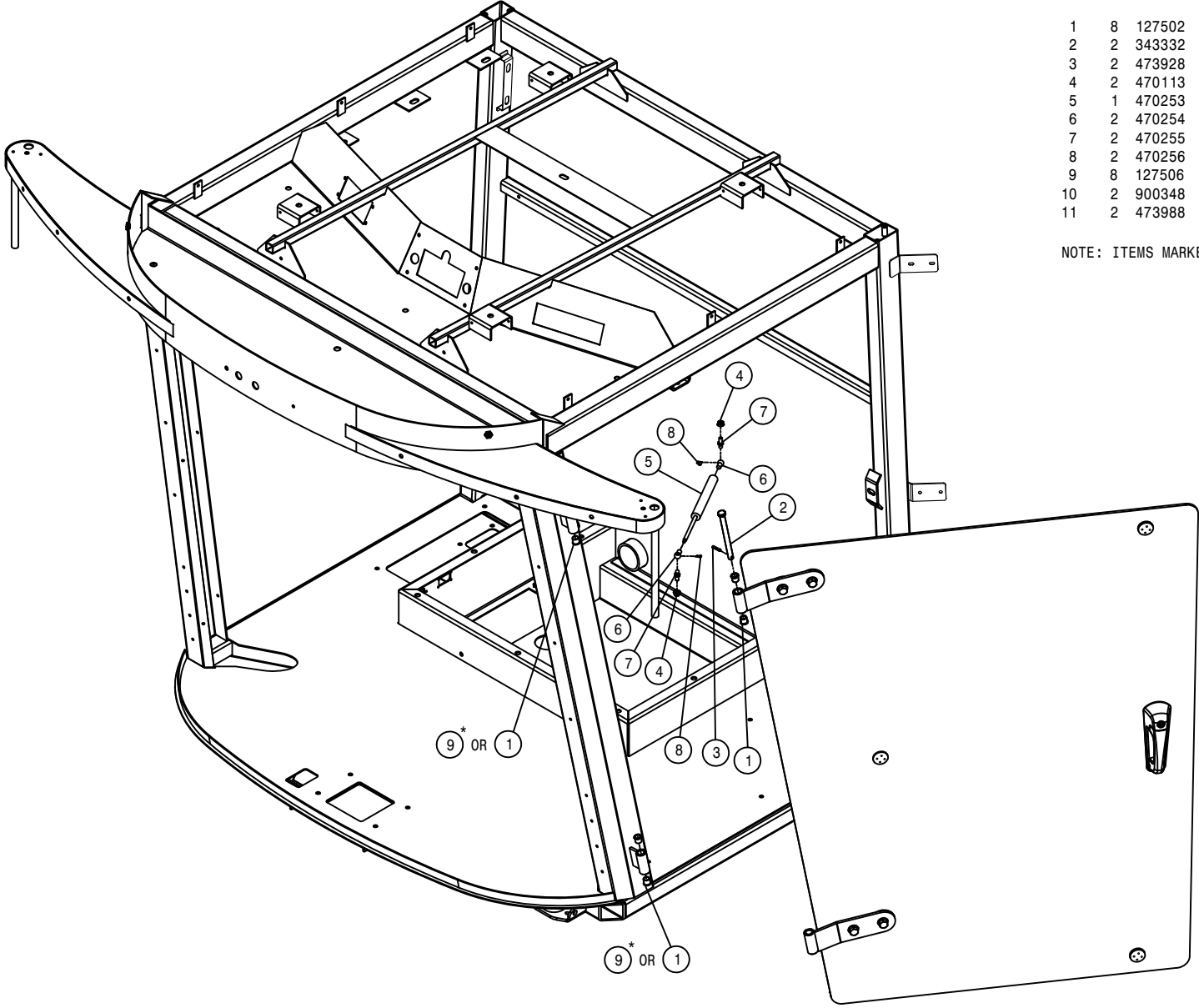

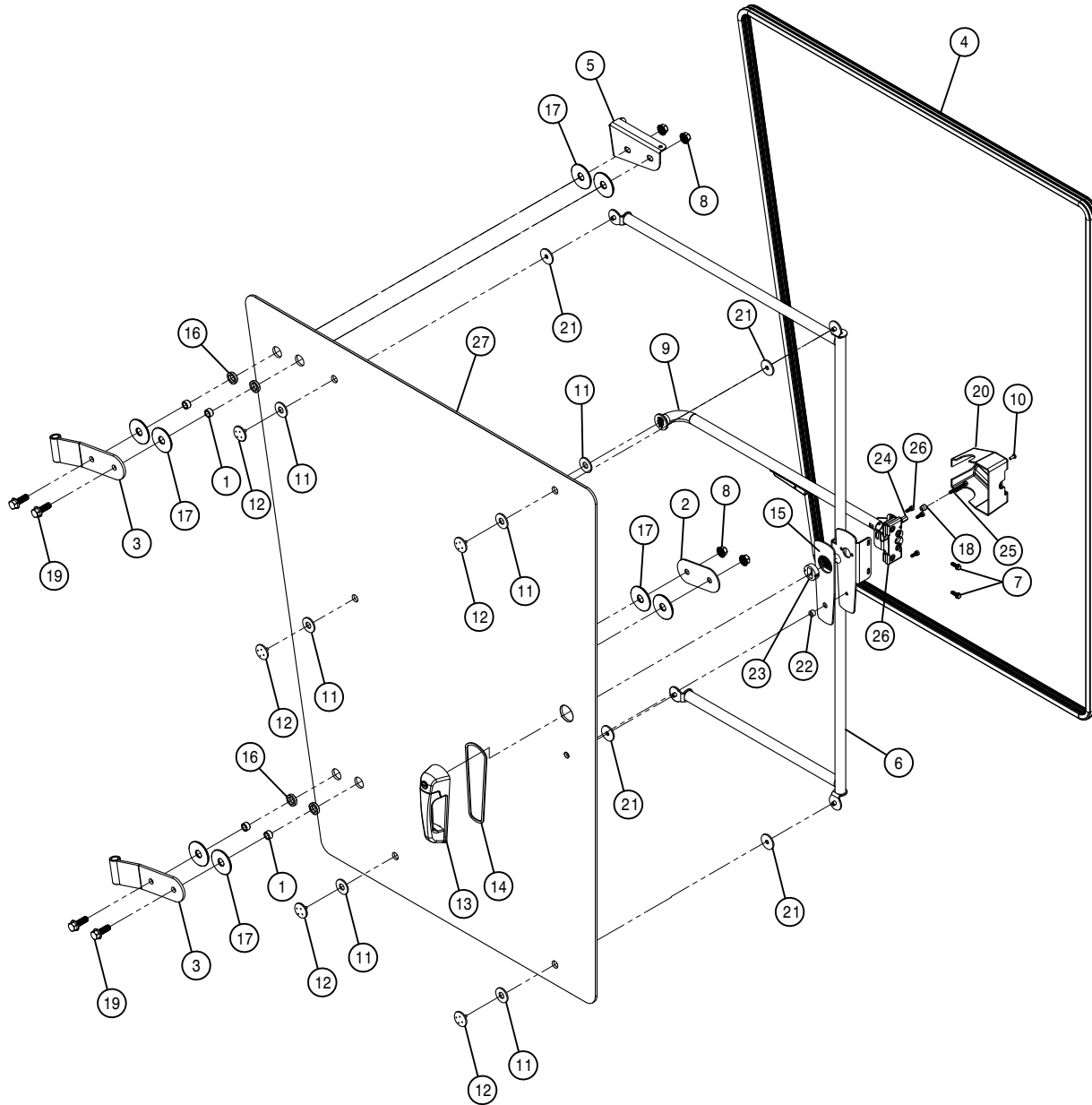

DOOR ASSEMBLY

DET. QTY PART NO. DESCRIPTION

DET.	QTY	PART NO.	DESCRIPTION	
1	4	343335	DOOR HINGE GLASS BUSH, CAB	05
2	1	343337	LWR DOOR HINGE BACK PLT,	05
3	2	343338	HINGE WELD,CAB	05
4	1	343346	DOOR SEAL, STS CAB	05
5	1	343421	TOP DOOR HINGE PLT, STS	05
6	1	343814	CAB DOOR STIFF WLD, STS	'11
7	2	470118	1/4UNC X 3/4 FLANGE HEX BOLT	
8	4	470360	1/2UNC HEX FLANGE LOCK NUT	
9	1	470583	INSIDE SQUEEZE LATCH ASY,1-POS	
10	1	470412	INSIDE SQUEEZE LATCH SCREWS	
11	6	470413	INSIDE SQUEEZE LATCH GASKET	
12	5	470414	INSIDE SQUEEZE LATCH CAP	
13	1	470415	OUTSIDE PULL HANDLE ASSY	
14	1	470416	OUTSIDE PULL HANDLE GASKET	
15	1	470418	DOOR HANDLE MT GASKET,STS CAB	
16	4	470419	DOOR HINGE BUSH,RUBBER STS	05
17	8	470420	DOOR HINGE WASH,RUBBER,STS	05
18	1	470421	NYLON SPACER, SPHERICAL 6MMX12	
19	4	470431	1/2UNC X 1 1/2 FLANGE BOLT	
20	1	470485	INSIDE SQUEEZE LATCH COVER	07
21	2	470489	GASKET, DOOR HANDLE STIFFENER	
22	1	470496	SPACER,BTM,DOOR HANDLE	470415
23	1	470497	SPACER,TOP,DOOR HANDLE	470415
24	1	473764	6MM-1.00 HEX HIGH NUT	
25	1	473794	6MM-1.00 X 50MM HEX BOLT	
26	3	473826	6MM-1.00 X 16MM HEX BOLT	
27	1	658041	DOOR GLASS, STS CAB	'11

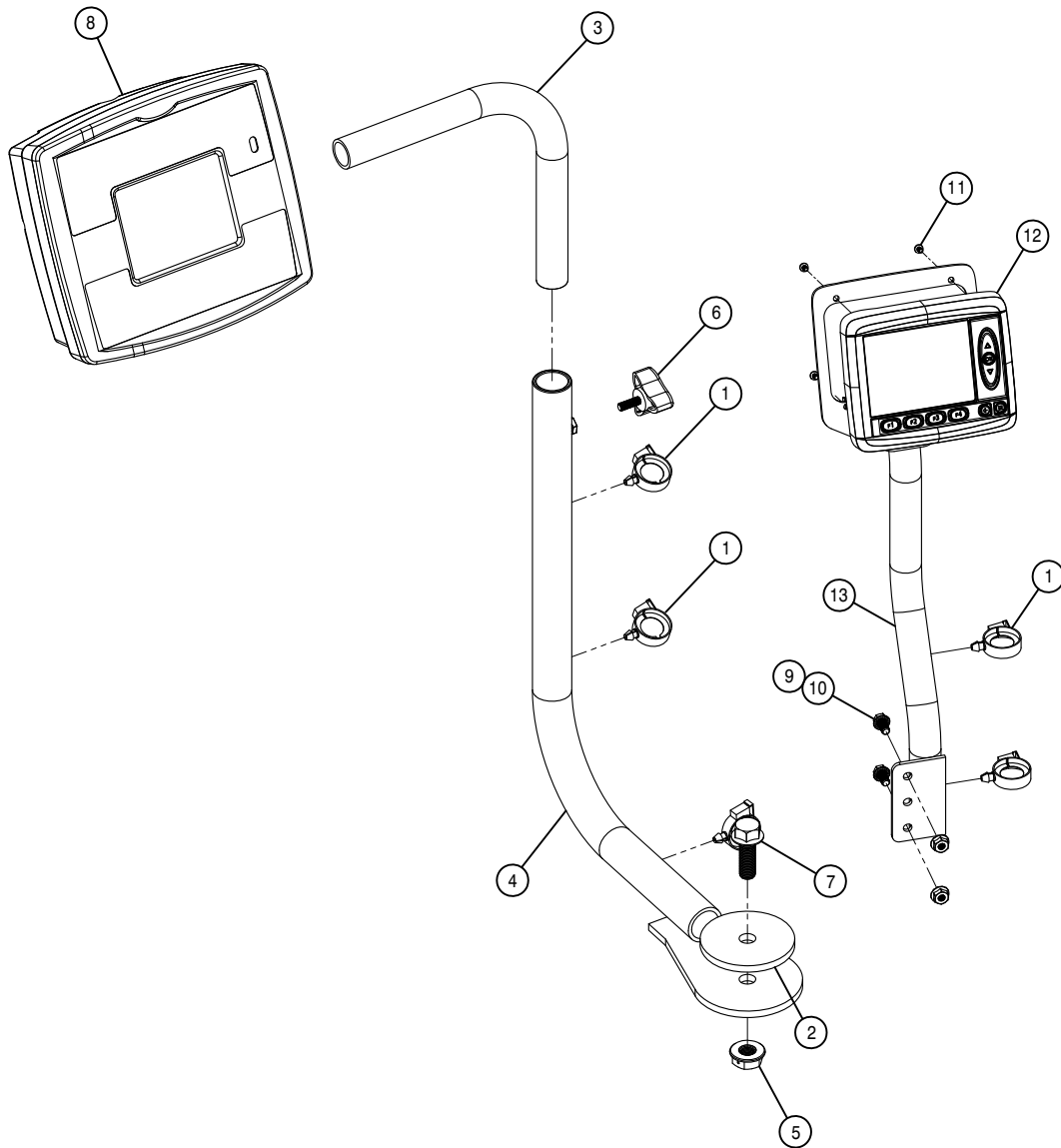

MONITOR ASSEMBLY

DET. QTY PART NO. DESCRIPTION

1	6	291007	ROSEBUD CLIP FOR .750 CONDUIT
2	1	343415	WASHER,3.00 X .531 X .25T UHMW
3	1	343416	MONITOR MT TUBE, STS 05
4	1	343417	MONITOR MT WELD, STS CAB 05
5	1	470345	1/2UNC HEX SMTH FLNG LOCK NUT
6	1	470392	KNOB,3-BLADE BLK,1/4-20 X 3/4
7	1	470431	1/2UNC X 1 1/2 FLANGE LOCK
8	1	690986	CONSOLE, RAVEN SCS 4600
9	2	470121	1/4UNC HEX FLANGE LOCK NUT
10	2	470122	1/4UNC X 1/2 FLANGE HEX BOLT
11	4	903836	8-32X1/4 PHIL PAN MACH SCR
12	1	292008	MD3 MASTER MODULE & DISPLAY
13	1	343678	MD3 DISPLAY MT WLD,STS '10

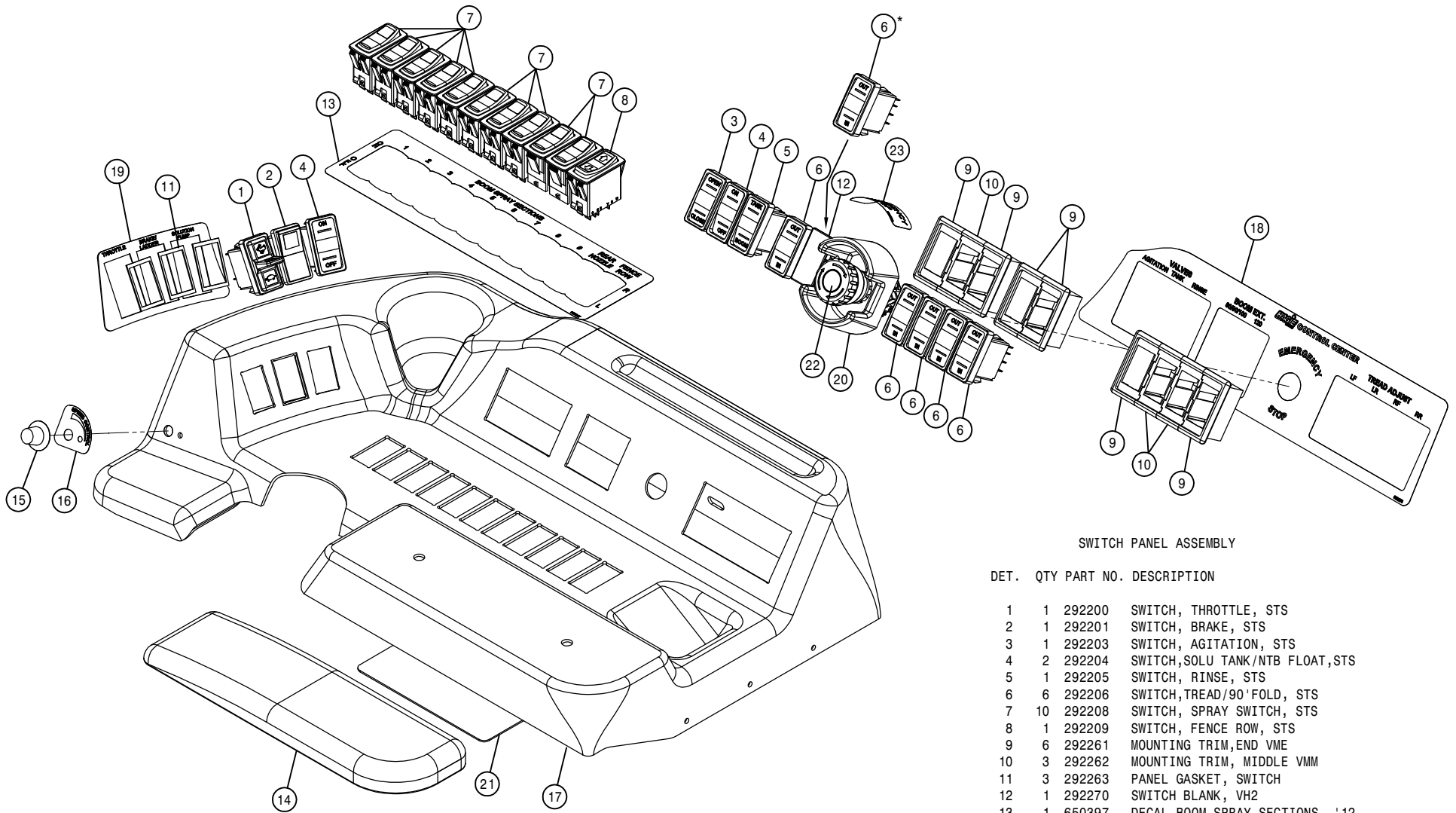

SWITCH PANEL ASSEMBLY

DET. QTY PART NO. DESCRIPTION

1	1	292200	SWITCH, THROTTLE, STS
2	1	292201	SWITCH, BRAKE, STS
3	1	292203	SWITCH, AGITATION, STS
4	2	292204	SWITCH, SOLU TANK/NTB FLOAT, STS
5	1	292205	SWITCH, RINSE, STS
6	6	292206	SWITCH, TREAD/90' FOLD, STS
7	10	292208	SWITCH, SPRAY SWITCH, STS
8	1	292209	SWITCH, FENCE ROW, STS
9	6	292261	MOUNTING TRIM, END VME
10	3	292262	MOUNTING TRIM, MIDDLE VMM
11	3	292263	PANEL GASKET, SWITCH
12	1	292270	SWITCH BLANK, VH2
13	1	650397	DECAL, BOOM SPRAY SECTIONS '12
14	1	343397	ARM REST W/MTS, STS CAB 05
15	1	470395	DIAL KNOB W/ARROW FOR .25 SHFT
16	1	650158	DECAL, SPEED CONTROL STS CAB 05
17	1	343823	SIDE CONSOLE, CAB STS'11
18	1	650275	DECAL, CONTROL CENTER, STS '11
19	1	650159	DECAL, THRTL BRK PUMP STS 05
20	1	290089	E-STOP SHROUD
21	1	650398	DECAL, CAB CONSOLE MODULES '12
22	1	290081	E-STOP SWITCH, LED DPST-1NO/1NC
23	1	650278	DECAL, E-STOP

NOTE: SWITCHES WITH (*) ARE USED WITH THE 120' BOOM OPTION.

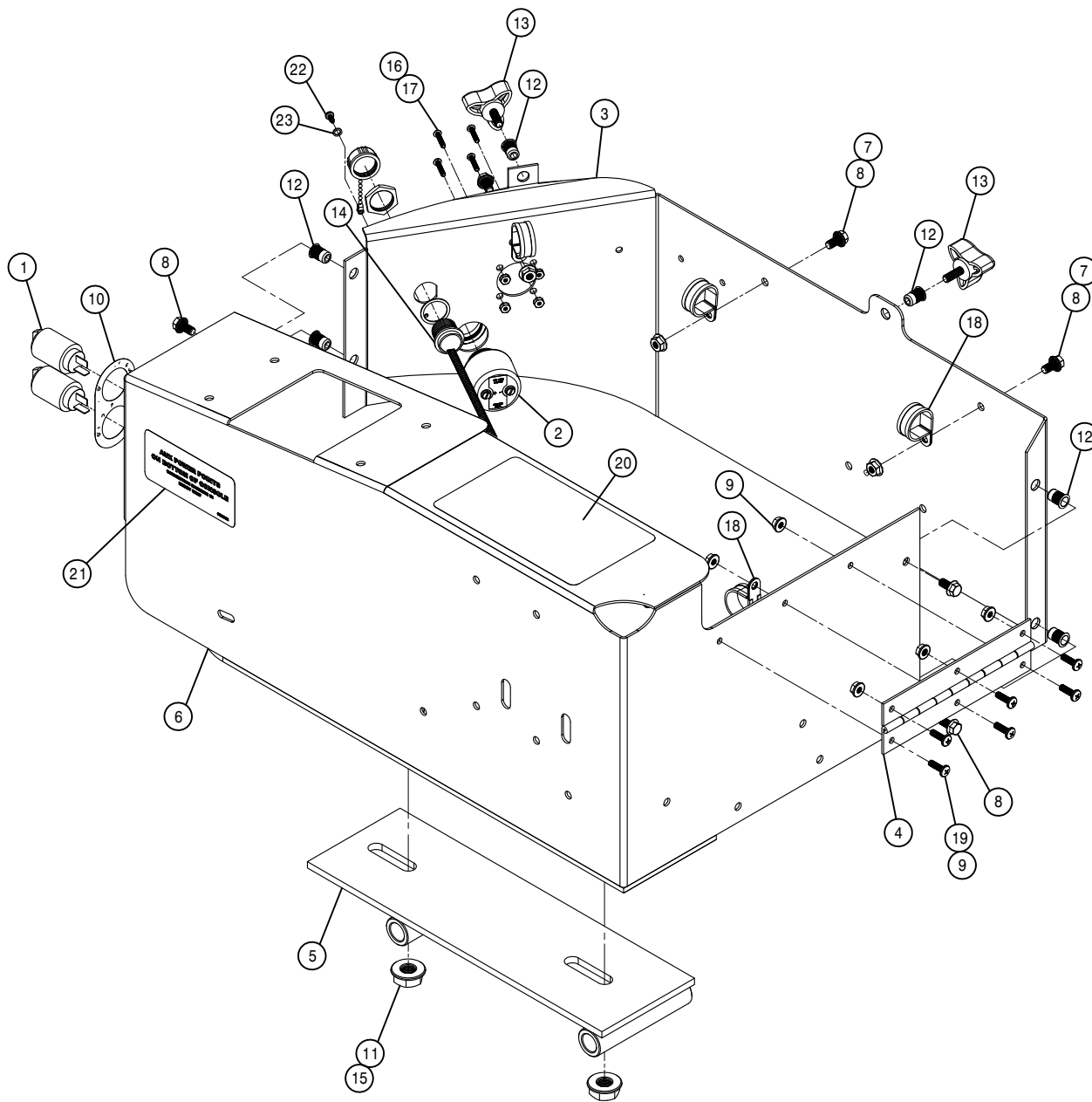

CONSOLE ASSEMBLY

DET. QTY PART NO. DESCRIPTION

1	2	291648	POWER POINT RECEPTACLE
2	1	292502	WARNING BEEPER
3	1	343685	SIDE CONSOLE OUTER WRAP,STS'10
4	1	343405	SIDE CONSOLE REAR HINGE,STS 05
5	1	343406	CONSOLE SEAT BASE WLD,STS 05
6	1	343682	CONSOLE WELD, STS CAB '10
7	3	470121	1/4UNC HEX FLANGE LOCK NUT
8	7	470122	1/4UNC X 1/2 FLANGE HEX BOLT
9	6	470175	10-32 HEX FLANGE LOCK NUT
10	1	650163	DECAL,POWER POINT, STS CAB 05
11	2	470345	1/2UNC HEX SMTH FLNG LOCK NUT
12	6	470380	1/4-20 NUTSERT .027-.165 STL
13	2	470392	KNOB,3-BLADE BLK,1/4-20 X 3/4
14	1	293903	HARNESS, USB
15	2	470431	1/2UNC X 1 1/2 FLANGE BOLT
16	4	470467	6-32 KEP NUT
17	4	903814	6-32 X 3/4 PHIL PAN MACH SCR
18	4	520101	CUSH CLAMP,#16 1"D X 1/2W
19	6	903710	10-32X5/8 PHIL PANHD MACH SCR
20	1	650396	DECAL,CONSOLE FUSE-RELAY '12
21	1	650232	DECAL,AUX PWR POINTS SIGN '10
22	1	473932	6-32 X 3/8 PAN SELF TAP SCR
23	1	470351	#10 X 1/2 BONDED SEALING WASH

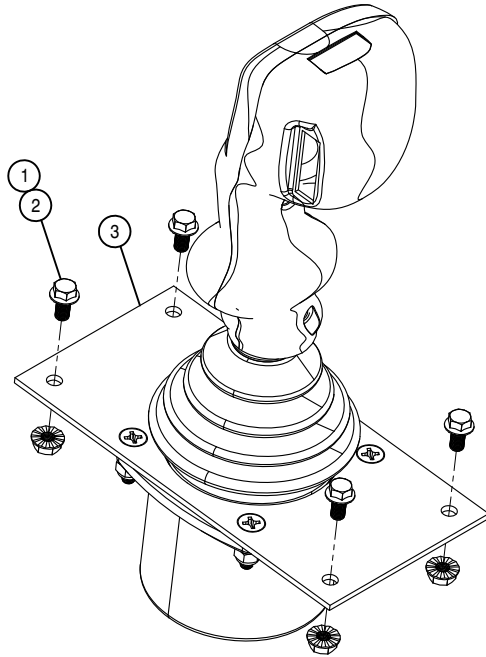

HYDROSTATIC LEVER ASSEMBLY

DET. QTY PART NO. DESCRIPTION

1	4	470121	1/4UNC HEX FLANGE LOCK NUT
2	4	470122	1/4UNC X 1/2 FLANGE HEX BOLT
3	1	785092	CONTROL HANDLE, STS '10

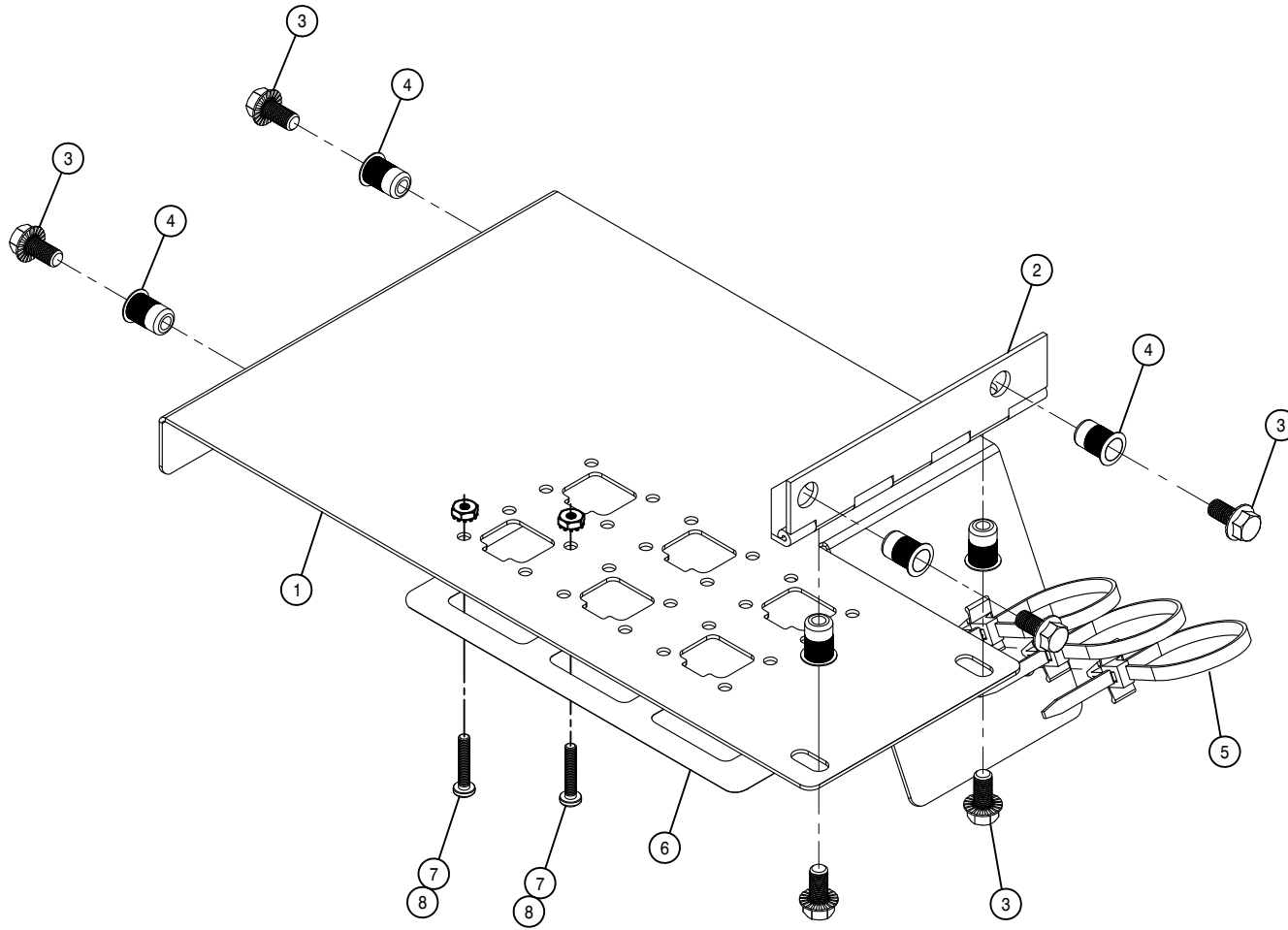

TERMINAL STRIP DOOR ASSEMBLY

DET. QTY PART NO. DESCRIPTION

1	1	343688	CONSOLE BOTTOM DOOR,CAB STS'10
2	1	343414	CONSOLE BTM DOOR HINGE,CAB STS
3	6	470122	1/4UNC X 1/2 FLANGE HEX BOLT
4	6	470380	1/4-20 NUTSERT .027-.165 STL
5	3	470445	CABLE TIE,PUSH MT 7.8" BLK NYL
6	1	650231	DECAL,AUX POWER POINTS '10
7	12	903814	6-32 X 3/4 PHIL PAN MACH SCR
8	12	470467	6-32 KEP NUT

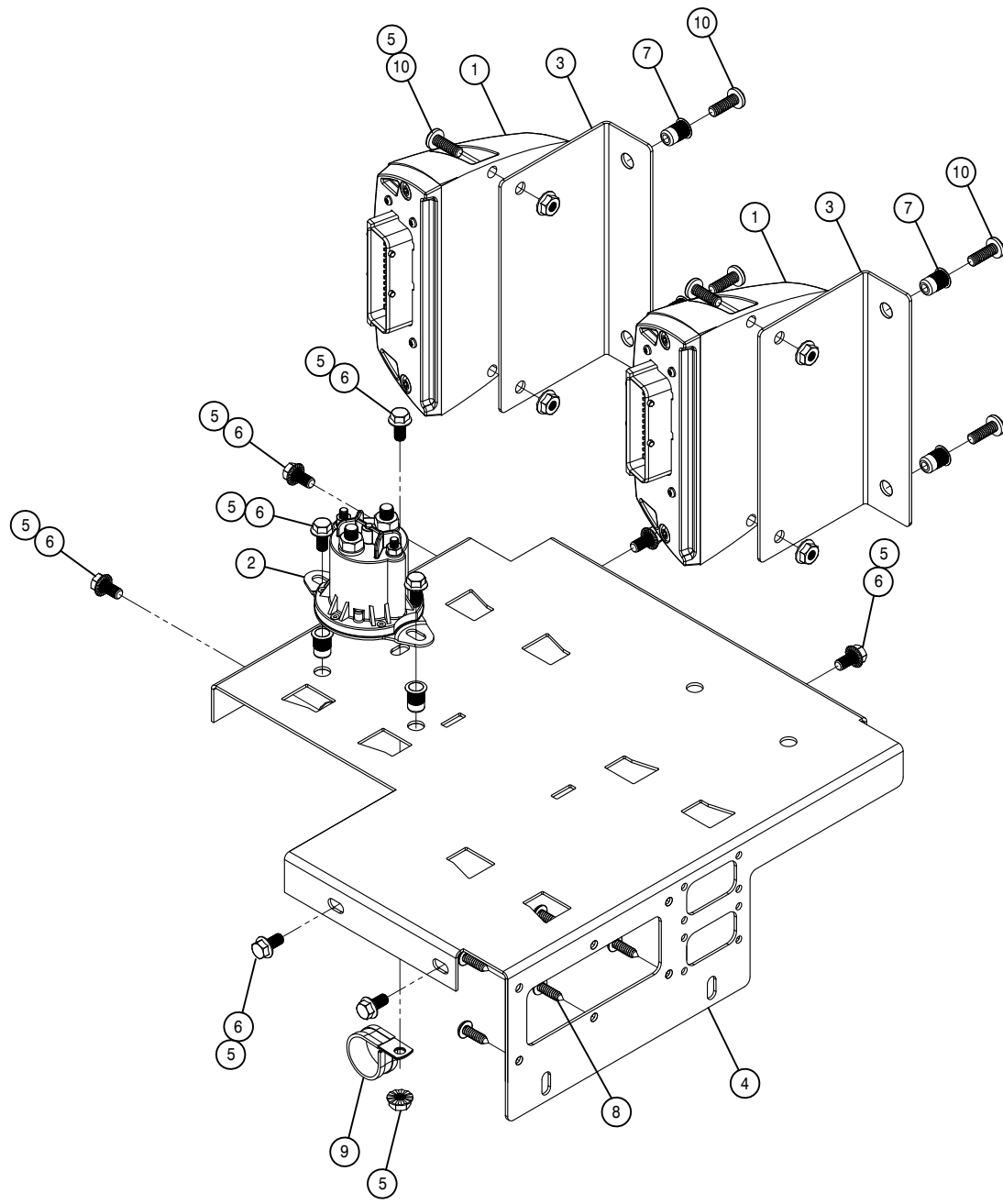

MODULE MOUNT ASSEMBLY

DET.	QTY	PART NO.	DESCRIPTION
	1	292017	IQAN-XS2 MODULE
	2	292505	MASTER CONTROL RELAY
	3	343686	MODULE MT BRKT, STS '10
	4	343687	MODULE MT, CAB CONSOLE STS '10
	5	11	1/4UNC HEX FLANGE LOCK NUT
	6	9	1/4UNC X 1/2 FLANGE HEX BOLT
	7	6	470380 1/4-20 NUTSERT .027-.165 STL
	8	6	470465 #12 X 3/4 PHIL PAN SHT MTL SCR
	9	1	520101 CUSH CLAMP,#16 1"D X 1/2W
	10	8	903700 1/4UNC X 3/4 PHIL PAN MACH SCR

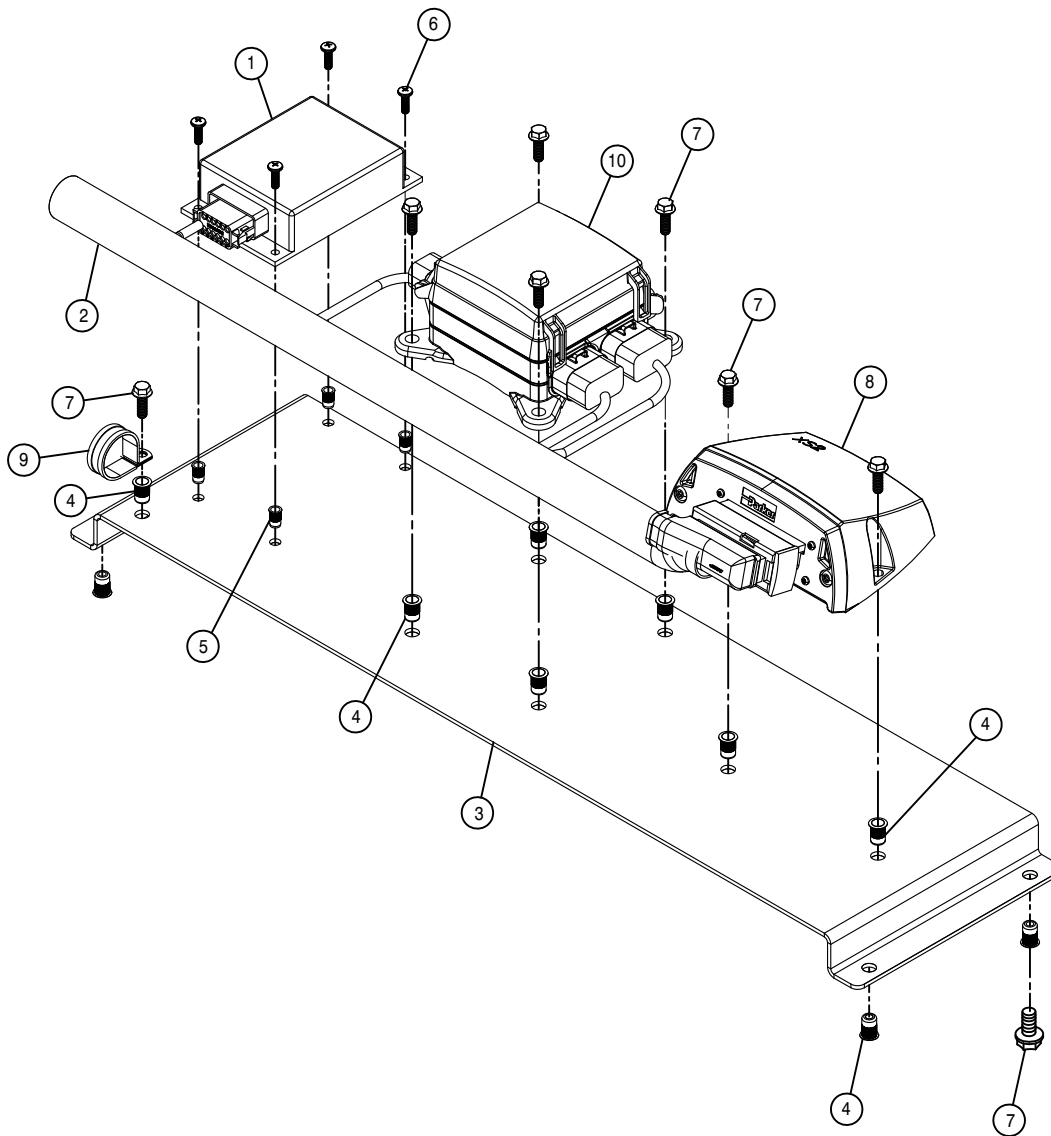

FLASHER AND LIGHT RELAY PANEL

DET. QTY PART NO. DESCRIPTION

1	1	291910	FLASHER, SOLID STATE, 12V
2	1	294155	LIGHT FLASHER HARNESS STS' 12
3	1	343693	FLASHER/LIGHT RELAY PLT, STS' 12
4	4	470380	1/4-20 NUTSERT .027-.165 STL
5	4	470384	10-32 NUTSERT .020-.130 STL
6	4	903710	10-32X5/8 PHIL PANHD MACH SCR
7	12	470118	1/4UNC X 3/4 FLANGE HEX BOLT
8	1	292016	IQAN-XA2 MODULE
9	2	520102	CUSH CLAMP, #20 1 1/4 X 1/2W
10	1	290093	FUSE/RELAY MODULE, BUSS1717-0S

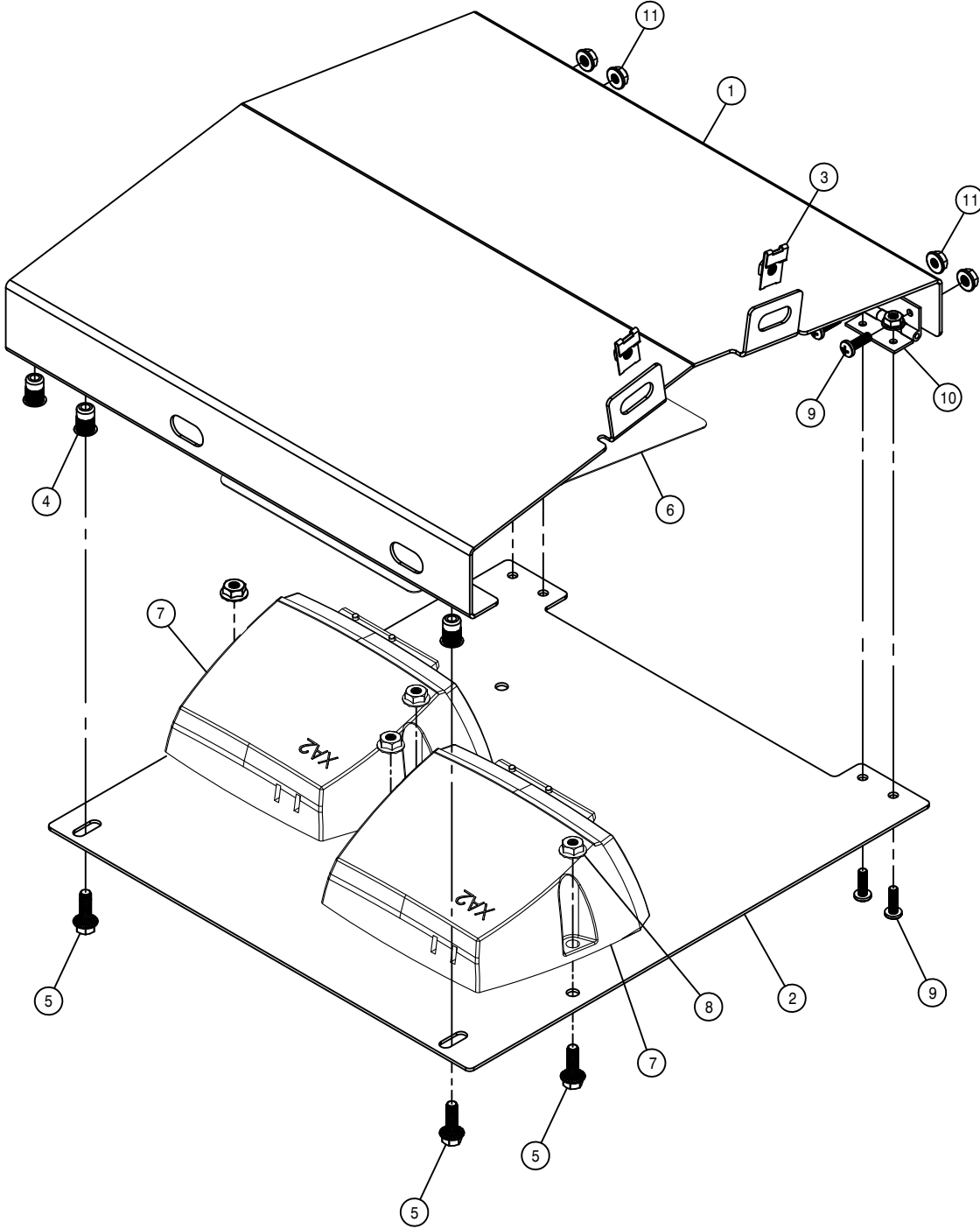

REAR ELECTRICAL BOX ASSEMBLY

DET.	QTY	PART NO.	DESCRIPTION
	1	343577	TOP LH REAR ELECT BOX, STS 06
	1	343578	BOT LH REAR ELECT BOX, STS 06
	2	470218	1/4UNC NUT J-TYPE CAGE CLIP
	4	470380	1/4-20 NUTSERT .027-.165 STL
	6	470118	1/4UNC X 3/4 FLANGE HEX BOLT
	1	650402	DECAL,REAR CHASSIS MODULE '12
	2	292016	IQAN-XA2 MODULE
	4	470121	1/4UNC HEX FLANGE LOCK NUT
	8	903710	10-32X5/8 PHIL PANHD MACH SCR
	10	470198	HINGE 146-035
	8	470175	10-32 HEX FLANGE LOCK NUT

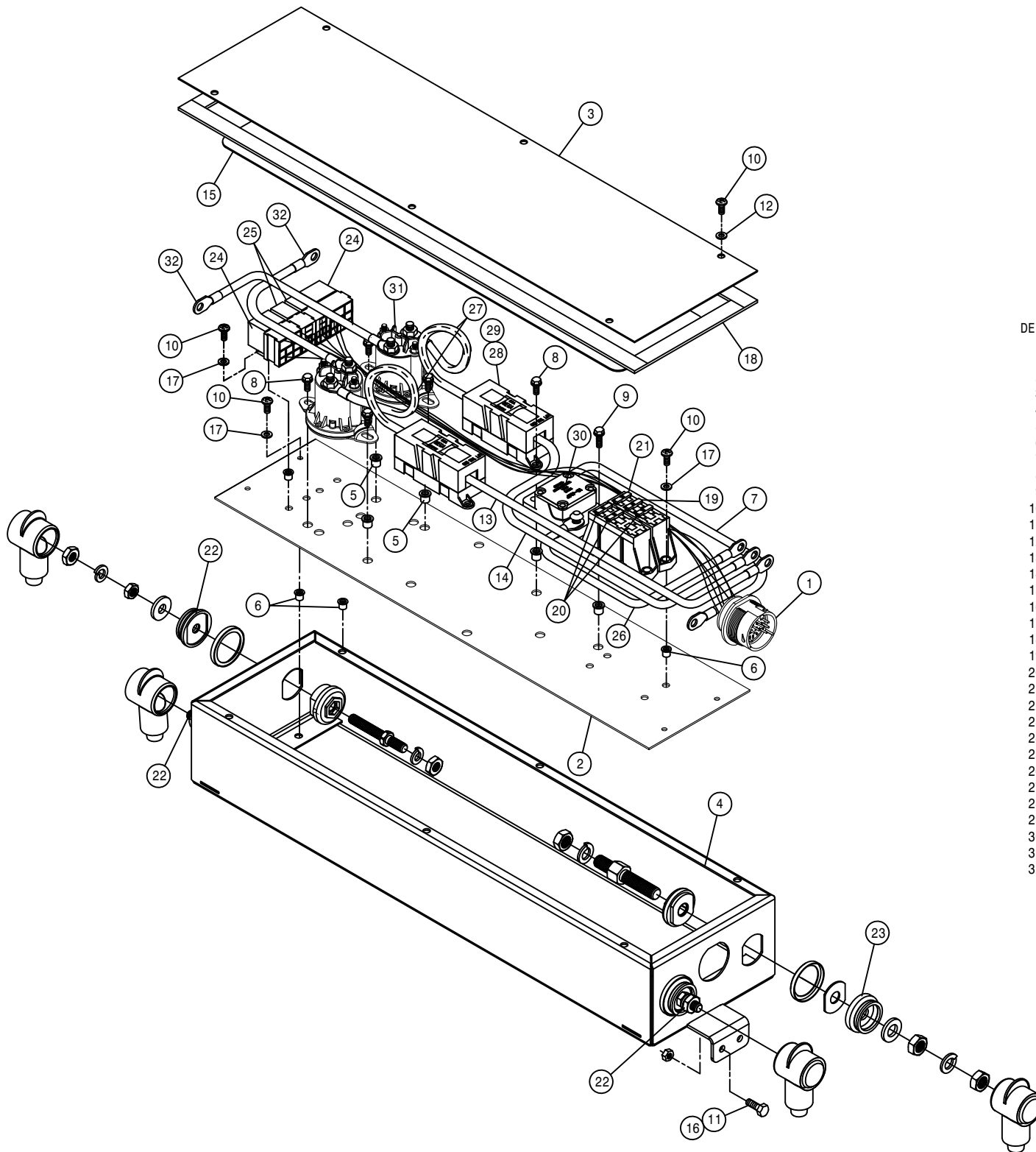

ENGINE ELECTRICAL BOX ASSEMBLY

DET. QTY PART NO. DESCRIPTION

1	1	293936	ENG ELECT BOX HARNESS,STS '10
2	1	342960	ENG BOX MT PANEL, STS '04
3	1	342961	ENG BOX COVER, STS '04
4	1	343703	ENG BOX WLD, STS '11
5	10	470380	1/4-20 NUTSERT .027-.165 STL
6	18	470384	10-32 NUTSERT .020-.130 STL
7	1	292538	BATT CABLE,RED 15*6GA 281-406
8	8	470122	1/4UNC X 1/2 FLANGE HEX BOLT
9	2	470118	1/4UNC X 3/4 FLANGE HEX BOLT
10	18	903710	10-32X5/8 PHIL PANHD MACH SCR
11	4	900002	1/4UNC X 3/4 HEX BOLT
12	6	470351	#10 X 1/2 BONDED SEALING WASH
13	1	292539	BATT CABLE,RED 15*6GA 343-531
14	1	292540	BATT CABLE,RED 19*6GA 343-531
15	1	650234	DECAL,ENG ELECTRIC BOX,STS '10
16	4	914000	1/4UNC HEX STOVER NUT
17	12	920510	#10 LOCK WASHER
18	5.5	193037	STICKERTITE 1/8 X 3/4
19	1	291549	30 AMP FUSE,LED 1/4"BLADE,ATC
20	3	291546	15 AMP FUSE,LED 1/4"BLADE,ATC
21	1	291547	20 AMP FUSE,LED 1/4"BLADE,ATC
22	3	291343	POWER BUSHING,3/8" RED WTHRPRF
23	1	291344	POWER BUSHING,1/2" RED WTHRPRF
24	2	291751	RELAY,SPDT,BKT MT,DIODE,5T
25	2	291781	MICRO RELAY, BOSCH 12V SPDT
26	1	292537	BATT CABLE,RED 12*6GA 281-531
27	2	291806	BATT CABLE,RED 11*6GA.343-.343
28	2	291813	FUSE, 125 AMP 32V DC
29	2	291814	FUSE HOLDER, HIGH AMP
30	1	292501	CIRCUIT BREAKER,120 AMP, BUSS
31	2	292505	MASTER CONTROL RELAY
32	2	292536	BATT CABLE,RED 10*6GA 343-406

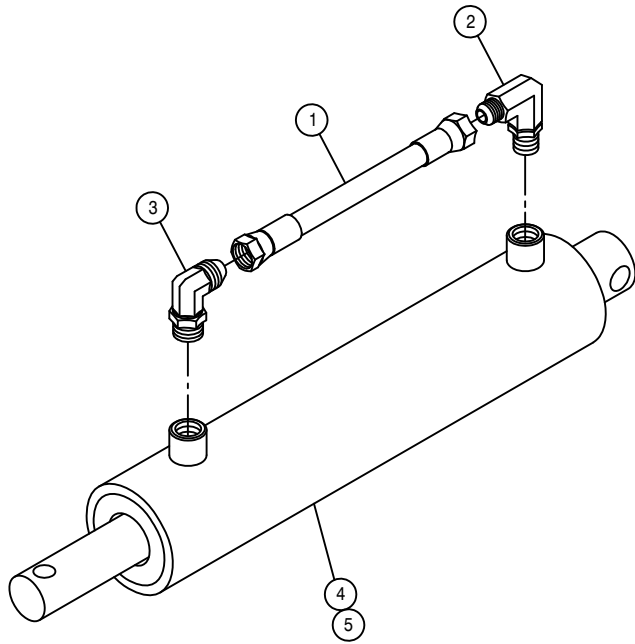

HOOD HYDRAULIC CYLINDER ASSEMBLY

DET. QTY PART NO. DESCRIPTION

1	1	616246	04-451TC-06FJX-06FJX-10	H/A
2	1	618119	9/16MJIC-90-9/16MOR LBO	
3	1	618689	9/16MJ-90-9/16MOR .042 CHK VLV	
4	1	621530	HYD CYL, 2.00 X 6.00 X 1.000	
5	1	621531	SUB>621521:KIT, HYD CYL 621530	

NOTE: 1. 621077 - HOOD HYDRAULIC CYLINDER ASSEMBLY

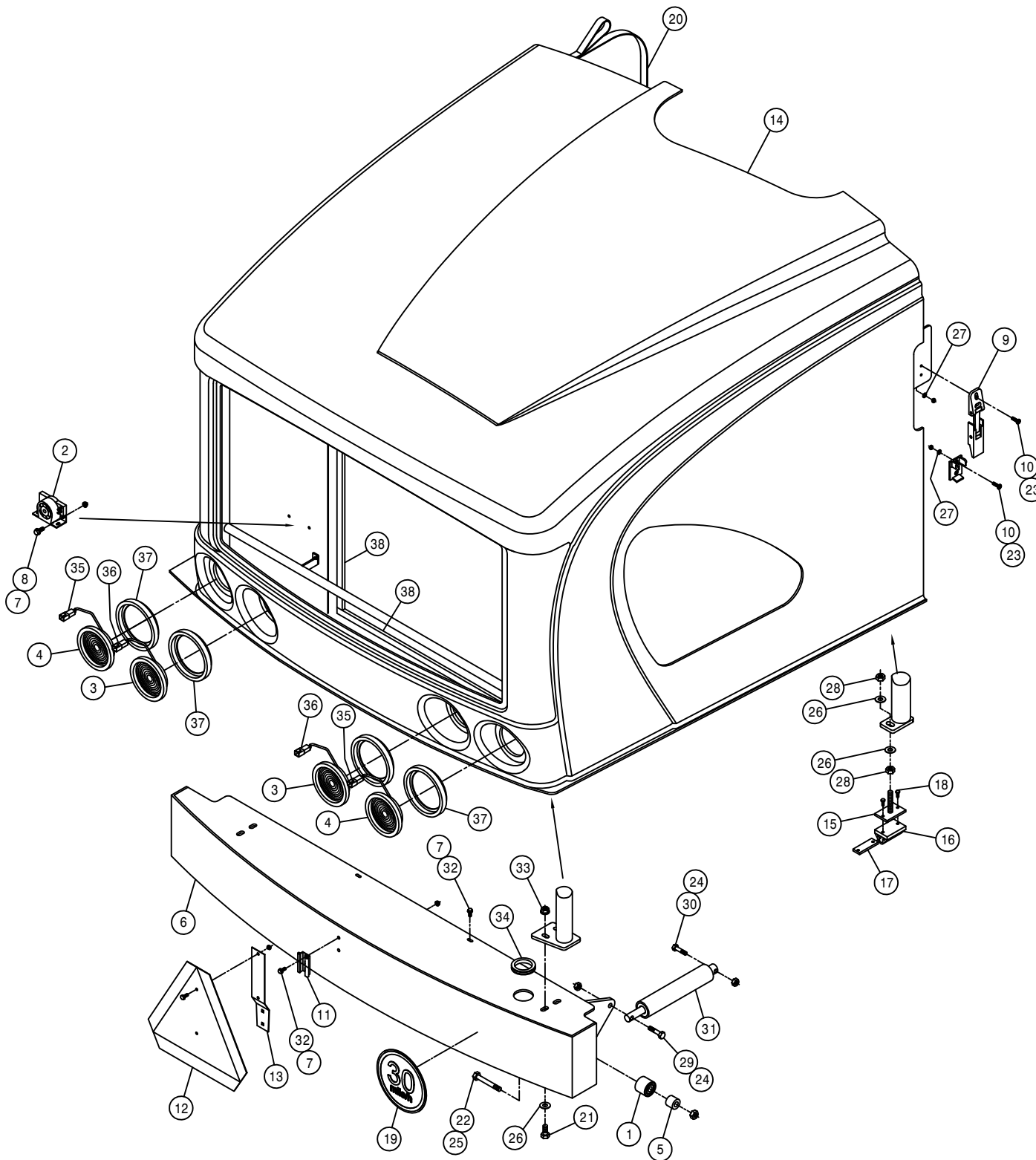

BUMPER AND REAR HOOD ASSEMBLY

DET.	QTY	PART NO.	DESCRIPTION
	1	2	125056 TRACK ROLLER,2.00 OD, .625 BORE
	2	1	290061 ALARM,BACKUP 107DBA LT DUTY
	3	2	290201 RED LED STT 3 DIODE LAMP
	4	2	290200 AMBER LED STT 3 DIODE LAMP
	5	2	361679 BUMPER PIVOT BRG SPACER,STS 04
	6	1	361680 REAR BUMPER WLD, STS 04
	7	6	470121 1/4UNC HEX FLANGE LOCK NUT
	8	2	470122 1/4UNC X 1/2 FLANGE HEX BOLT
	9	2	470368 LATCH W/KEEPER, FLEXIBLE LEVER
	10	8	903710 10-32X5/8 PHIL PANHD MACH SCR
	11	1	472251 MTG SOCKET FOR 472249 SMV SIGN
	12	1	472249 SLOW MOVING VEHICLE SIGN, SMV
	13	1	472250 SPADE MTG BRKT FOR 472249 SMV
	14	1	660222 REAR ENGINE HOOD, STS 04
	15	2	660224 ENG HOOD BUMPER WLD, STS 04
	16	2	660226 ENG HOOD BUMPER, STS 04
	17	2	660227 ENG HOOD BUMPER KEEPER, STS 04
	18	4	900003 1/4UNC X 1" HEX BOLT
	19	1	650223 DECAL,30MPH ID SYMBOL, VINYL
	20	1	660230 ENG HOOD PULL STRAP ASSY,STS04
	21	4	900265 1/2UNC X 1 1/2 HEX BOLT
	22	2	900341 5/8UNC X 3 3/4 HEX BOLT
	23	8	910027 10-32 HEX NUT
	24	2	473007 1/2UNC HEX NUT, NYLOC
	25	2	914010 5/8UNC HEX STOVER NUT
	26	8	920004 1/2 SAE FLAT WASHER
	27	8	920510 #10 LOCK WASHER
	28	4	910008 1/2UNC HEX NUT
	29	1	900267 1/2UNC X 2" HEX BOLT
	30	1	900268 1/2UNC X 2 1/2 HEX BOLT
	31	1	621077 HOOD HYD CYL ASSY, STS 04
	32	4	470118 1/4UNC X 3/4 FLANGE HEX BOLT
	33	4	470360 1/2UNC HEX FLANGE LOCK NUT
	34	1	470441 GROMMET, .500ID .250GW 2.190GD
	35	2	290202 2-WIRE PIGTAIL FOR 290200AMBER
	36	2	290203 3-WIRE PIGTAIL FOR 290201 RED
	37	4	290204 4" GROMMET FOR 290200 & 290201
	38	2	193066 FOAM,1" X 1.5 X 81"ADHVE STRIP

FRONT PANEL AND DOOR ASSEMBLY

DET. QTY PART NO. DESCRIPTION

DET.	QTY	PART NO.	DESCRIPTION	C/L
1	1	340330	.375 SCH40 BP X 1.25	C/L
2	4	470075	COTTER PIN 1/8 X 3/4	
3	4	470118	1/4UNC X 3/4 FLANGE HEX BOLT	
4	7	470121	1/4UNC HEX FLANGE LOCK NUT	
5	5	470122	1/4UNC X 1/2 FLANGE HEX BOLT	
6	1	470306	DOOR LATCH, RH TWO-ROTOR	
7	1	470325	7/16UNC HEX FLANGE LOCK NUT	
8	6	470335	LINCHPIN, 3/16 X 1 1/4 GRIP	
9	2	470367	FLAT HINGE, 180 DEG, DIECAST	
10	1	472324	ROLL PIN, 5/32 X 1/2	
11	2	900064	5/16UNC X 3/4 HEX BOLT	
12	4	660244	DOOR HINGE BRKT WLD STS LS	06
13	1	660246	FRT BELLY SHILD, STSLS	06
14	1	660247	REAR BELLY SHIELD, STSLS	06
15	1	660231	LWR ENG COVER, STS	04
16	1	660283	FRT ENG HOOD BRACE, STS10/12' 12	
17	1	660260	FRONT ENGINE HOOD, GST/STS	09
18	1	660221	AIR CLEANER DOOR, STS	04
19	1	660228	SIDE DOOR LATCH EXT, STS	04
20	2	660229	DOOR HINGE BACK PLATE, STS	04
21	2	900005	1/4UNC X 1 1/2 HEX BOLT	
22	4	900050	1/4UNC X 1 1/4 PH FLHD MAC SCR	
23	2	900277	1/2UNC X 5 1/2 HEX BOLT	
24	1	900216	7/16UNC X 2 1/2 HEX BOLT	
25	2	900265	1/2UNC X 1 1/2 HEX BOLT	
26	4	914000	1/4UNC HEX STOVER NUT	
27	2	914002	5/16UNC HEX STOVER NUT	
28	2	920001	5/16 SAE FLAT WASHER	
29	1	920003	7/16 SAE FLAT WASHER	
30	2	920004	1/2 SAE FLAT WASHER	
31	4	470360	1/2UNC HEX FLANGE LOCK NUT	
32	8	470233	5/16UNC X 3/4 FLANGE HEX BOLT	
33	8	470113	5/16UNC HEX FLANGE LOCK NUT	

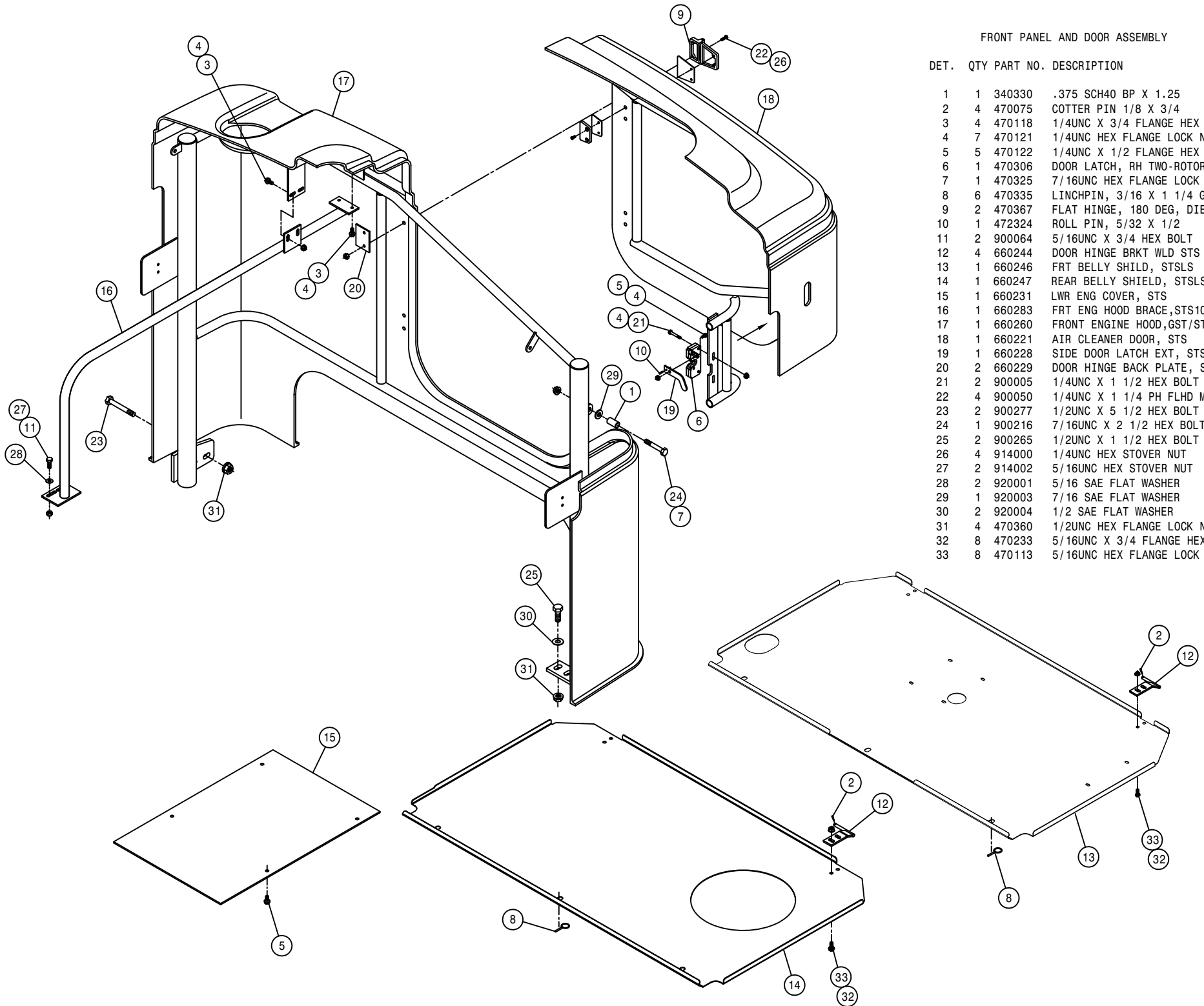

POLY RINSE TANK ASSEMBLY

DET. QTY PART NO. DESCRIPTION

1	5	500024	1"NPT-90-1"HOSE BARB, POLY
2	1	500063	1"NPT PIPE PLUG, POLY
3	1	763740	100 GAL POLY TANK, GRAY '11
4	1	763590	POLY RINSE TANK MT WLD STS12
5	1	763594	POLY RINSE TANK MT PAD STS12
6	2	763595	POLY RINSE TNK STRAP ASSY STS
7	2	900392	1/2UNC X 1 1/2 SOCKET CAP SCR
8	4	914008	1/2UNC HEX STOVER NUT
9	2	920004	1/2 SAE FLAT WASHER
10	2	500157	1" FLANGE GASKET EPDM
11	2	500159	1" FLANGE CLAMP, S.S.
12	1	500163	1" FLANGE-1" MNPT ADPTR POLY
13	1	500173	1" FLANGE-90-1" HOSE BARB POLY
14	1	505198	SS PIPE NIPPLE 1.00NPT-3.00
15	1	690660	LINE T-STRAINER,1"FLG,W/O SCR
16	1	690669	100 MESH SCREEN FOR 690660
17	1	696004	BALL VLV,1.00NP 3WAY-SIDE POLY
18	5	520090	HOSE CLAMP NO 16 STAINLESS
19	1	601522	HOSE, 1 X 204 1BR BLK EPDM
20	1	601492	HOSE, 1 X 37 1BR BLK EPDM
21	1	601497	HOSE, 1 X 206 1BR BLK EPDM
22	1	601318	HOSE, 1 X 254 1BR BLK EPDM
23	1	701155	8" LID FOR 5 GAL TANK 701085
24	1	601742	HOSE, 1" X 16 CLEAR VINYL
25	1	763623	GREEN POLYPROPYLENE BALL .750"
26	2	500107	1"NPT SWIVEL POLY

NOTE * FRONT FILL OPTION
** SIDE FILL OPTION

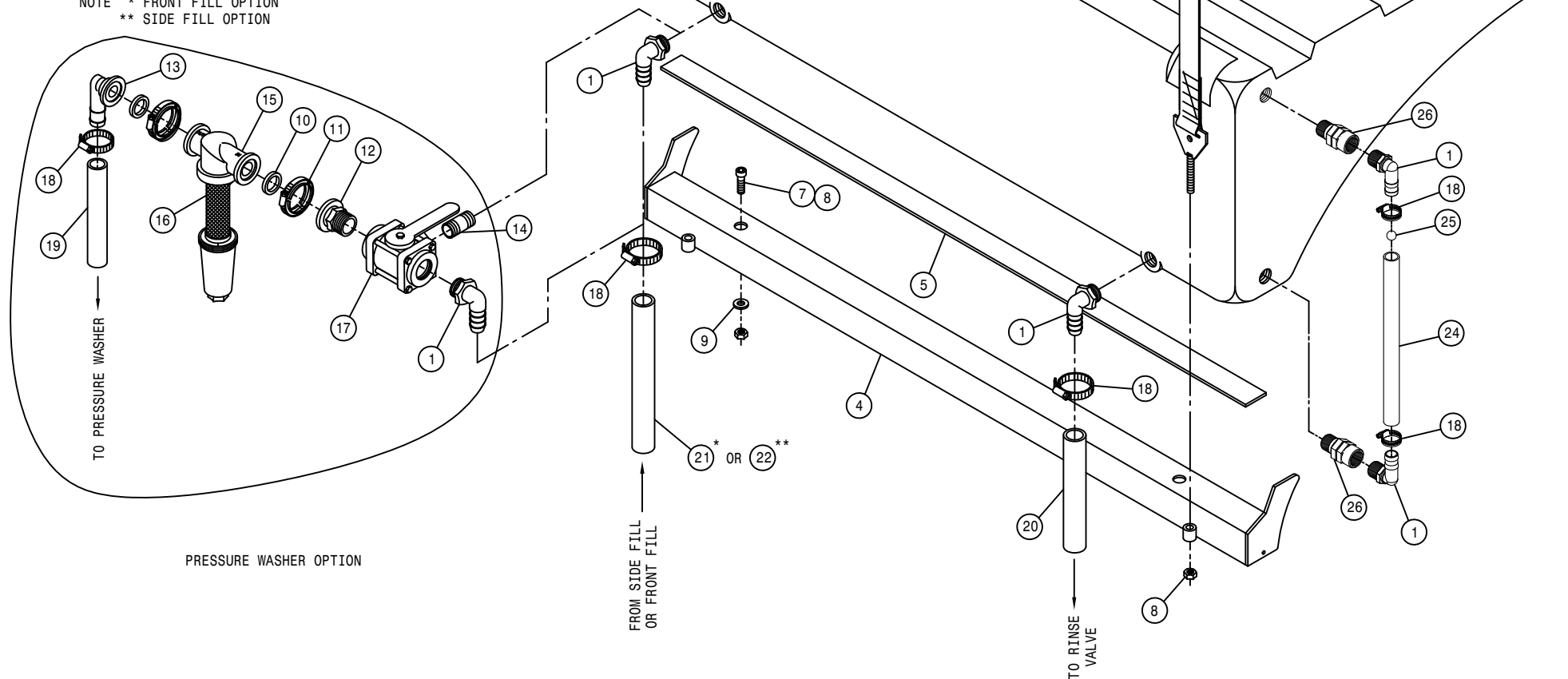

PRESSURE WASHER OPTION

1200 GALLON SS TANK ASSEMBLY

DET. QTY PART NO. DESCRIPTION

1	1	500063	1"NPT PIPE PLUG, POLY
2	1	500047	1/2"NPT-90-1/2 HOSE BARB, POLY
3	1	500104	1/4"NPT-90-1/4 HOSE BARB, POLY
4	6	500157	1" FLANGE GASKET EPDM
5	3	500158	1 1/2" GASKET FOR 2" FLANGE
6	6	500159	1" FLANGE CLAMP, S.S.
7	3	500160	2" FLANGE CLAMP, S.S.
8	1	500171	1" FLANGE-1" HOSE BARB POLY
9	1	500175	1" FLANGE TEE POLY
10	3	470118	1/4UNC X 3/4 FLANGE HEX BOLT
11	4	500194	2"FP FLANGE CLAMP, S.S.
12	4	500195	2"FP FLANGE GASKET EPDM
13	1	500197	2" FP FLANGE-90-1 1/2 HBARB
14	1	500226	1" FLANGE PLUG W/1/4"FNPT POLY
15	1	500238	1" FLANGE PLUG W/1/2"FNPT POLY
16	1	507103	PIPE CAP, 2.00FNPT S.S.
17	1	520067	HOSE CLAMP NO 28 STAINLESS
18	1	520070	HOSE CLAMP NO 8 STAINLESS
19	2	520090	HOSE CLAMP NO 16 STAINLESS
20	1	520120	HOSE CLAMP NO 4 STAINLESS
21	1	601704	HOSE, 1 X 140 1BR BLK EPDM
22	3	470089	1/4UNC HEX NYLOC NUT, 316 SS
23	1	601591	HOSE, 1 1/2 X 53 2BR BLK EPDM
24	1	601676	HOSE, 1/2 X 270 1BR BLK EPDM
25	1	601674	HOSE, 1/4 X 120 1 BR BLK EPDM
26	1	763726	1200 GAL SS TANK '11
27	7	500208	3" FLANGE CLAMP, S.S.
28	7	500209	3" FLANGE GASKET EPDM
29	3	500210	3" FLANGE-3" HOSE BARB POLY
30	2	500213	3"FLANGE-90-3"FLANGE LBO POLY
31	1	696149	BALL VLV, 3" FLANGE
32	2	500164	3" FLANGE-3" MNPT ADPTR POLY
33	1	696268	VALVE, 3" KZCO
34	1	500196	2"FP FLANGE-2" HOSE BARB POLY
35	1	500212	3"FLANGE-2"FP FLANGE REDU POLY
36	1	500219	2"FP FLANGE-90-2"FP FLANGE LBO
37	1	696258	VALVE, KZCO C2I-60B-Y19
38	1	601573	HOSE, 2 X 48 2F-1W EPDM
39	1	601663	HOSE, 3 X 50 POLY HELIX EPDM
40	1	520141	2.31/2.62 T-BOLT HOSE CLAMP SS
41	6	520145	3.56/3.88 T-BOLT HOSE CLAMP SS
42	1	500211	3" FLANGE-90-3" HOSE BARB POLY
43	1	601508	HOSE, 3 X 64 POLY HELIX EPDM
44	1	601680	HOSE, 3 X 91 POLY HELIX EPDM
45	1	601574	HOSE, 3 X 36 POLY HELIX EPDM
46	1	601664	HOSE, 3 X 55 POLY HELIX EPDM
47	1	690731	SOLU TUBE, 3.00 S.S. SIDE FILL
48	2	900064	5/16UNC X 3/4 HEX BOLT
49	2	914002	5/16UNC HEX STOVER NUT
50	2	470321	IND BELT, 4.00 X 67.00 .203THK
51	1	763811	SIGHT GAUGE TUBE ASSY STS'12
52	4	482016	SPRING, 1.40 X 3.00 COMPRSN
53	4	900416	3/4UNC X 6 1/2 HEX BOLT
54	4	914012	3/4UNC HEX STOVER NUT
55	8	920006	3/4 SAE FLAT WASHER
56	1	763561	LID ASSY FOR 763550 TANK
57	1	763562	10" FILL LID SEAL FOR 763550
58	1	763563	16" MANHOLE SEAL FOR 763550
59	1	500024	1"NPT-90-1"HOSE BARB, POLY
60	1	601682	HOSE, 1 X 111 2BR BLK EPDM
61	1	500054	3/4NPT-90-3/4 HOSE BARB, POLY
62	1	500150	2" FLANGE-1" BRANCH TEE POLY
63	1	500154	2" FLANGE-2" HOSE BARB POLY
64	1	500180	2"FLANGE-90-2"FLANGE LBO, LONG
65	1	500185	1"FLANGE-90-3/4"HOSE BARB POLY
66	6	520055	HOSE CLAMP NO 12 STAINLESS
67	1	520068	HOSE CLAMP NO 32 STAINLESS
68	1	601767	HOSE, 3/4 X 16 CLEAR VINYL
69	1	601728	HOSE, 3/4 X 60 CLEAR VINYL
70	1	601743	HOSE, 2 X 113 2F-1W EPDM
71	2	650144	DECAL, LOGO, SOLU TANK STS'12
72	1	650406	DECAL, 1200G SS SIGHT GAUGE '12
73	1	763808	SIGHT GAUGE SUPPORT STS'12
74	3	470572	1.31ID U-BOLT HUB CLAMP
75	2	500108	1"NPT-3/4" HOSE BARB POLY
76	1	696193	3/4" HOSE BARB MICRO VALVE
77	1	601766	HOSE, 3/4 X 4 CLEAR VINYL

NOTE: ITEMS (*) ARE USED WITH THE SIDE FILL OPTION
 ITEMS (**) ARE USED WITH THE FRONT FILL OPTION

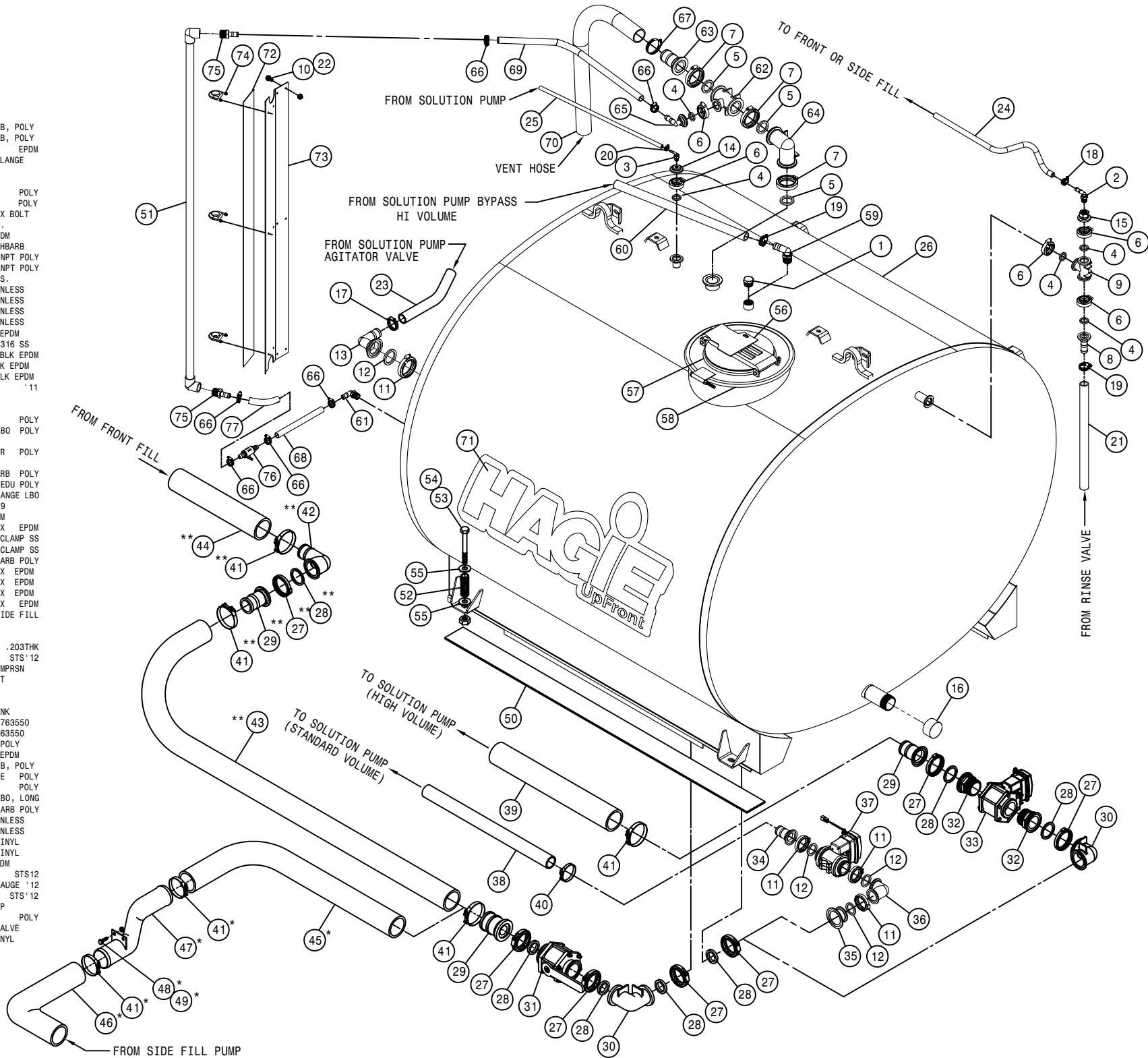

QUICK COUPLER ASSEMBLY

DET. QTY PART NO. DESCRIPTION

1	1	500154	2" FLANGE-2" HOSE BARB	POLY
2	3	500158	1 1/2" GASKET FOR 2" FLANGE	
3	3	500160	2" FLANGE CLAMP, S.S.	
4	1	500180	2"FLANGE-90-2"FLANGE LBO, LONG	
5	1	500225	2"FLANGE-45-2"FLANGE LBO	POLY
6	1	500152	2" FLANGE-2" MNPT ADPTR	POLY
7	1	690391	2.00FNPT-MALE COUPLER	POLY
8	1	601628	HOSE, 2 X 51 2F-1W EPDM	
9	2	520141	2.31/2.62 T-BOLT HOSE CLAMP SS	
10	1	690392	PLUG FOR 2.00 FEMALE COUPLER	
11	1	690272	2" FEM COUPLER W/LOCK, 2" BARB	
12	1	690623	CAP FOR 2.00 MALE COUPLER POLY	
13	1	500231	2"FP FLANGE GASKET, EXTRA THICK	
14	2	470322	LANYARD, 8" NYLON LOOP/LOOP	
15	1	520099	HOSE CLAMP NO 40 STAINLESS	

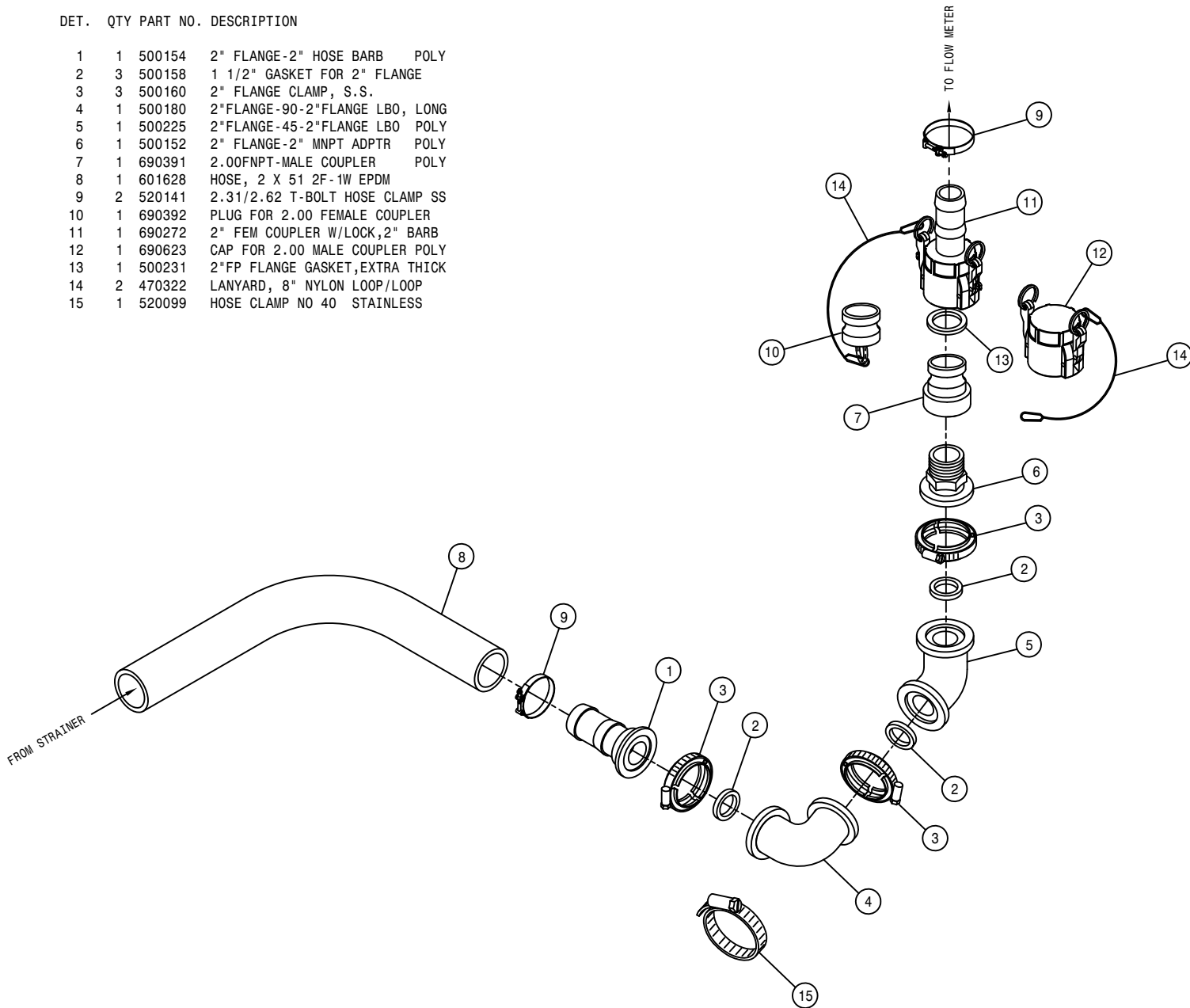

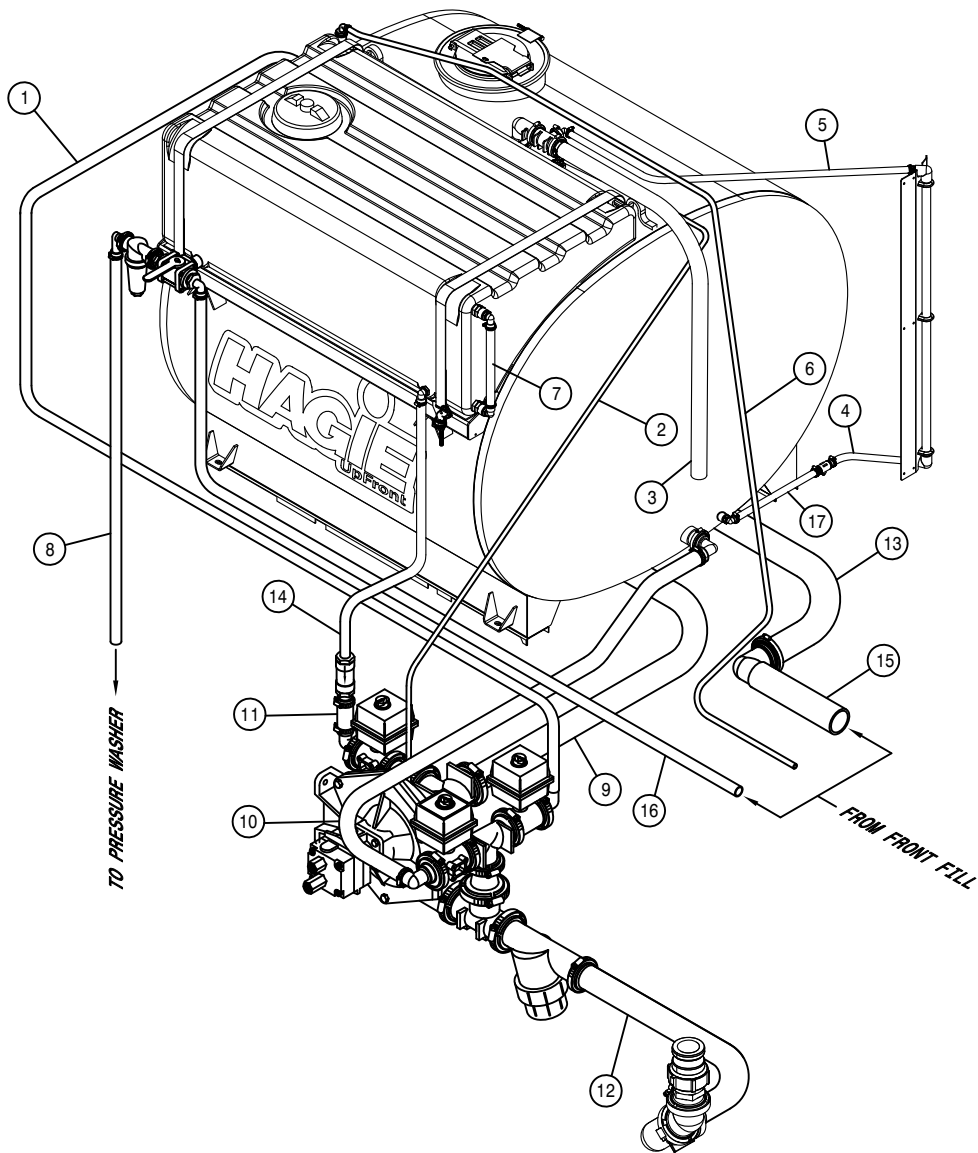

FRONT FILL SOLUTION HOISING (STD-VOLUME)

DET.	QTY	PART NO.	DESCRIPTION
1	1	601704	HOSE, 1 X 140 1BR BLK EPDM
2	1	601674	HOSE, 1/4 X 120 1 BR BLK EPDM
3	1	601743	HOSE, 2 X 113 2F-1W EPDM
4	1	601766	HOSE, 3/4 X 4 CLEAR VINYL
5	1	601728	HOSE, 3/4 X 60 CLEAR VINYL
6	1	601676	HOSE, 1/2 X 270 1BR BLK EPDM
7	1	601742	HOSE, 1" X 16 CLEAR VINYL
8	1	601522	HOSE, 1 X 204 1BR BLK EPDM
9	1	601573	HOSE, 2 X 48 2F-1W EPDM
10	1	601591	HOSE, 1 1/2 X 53 2BR BLK EPDM
11	1	601590	HOSE, 1 X 6 1BR BLK EPDM
12	1	601628	HOSE, 2 X 51 2F-1W EPDM
13	1	601508	HOSE, 3 X 64 POLY HELIX EPDM
14	1	601492	HOSE, 1 X 37 1BR BLK EPDM
15	1	601680	HOSE, 3 X 91 POLY HELIX EPDM
16	1	601497	HOSE, 1 X 206 1BR BLK EPDM
17	1	601767	HOSE, 3/4 X 16 CLEAR VINYL

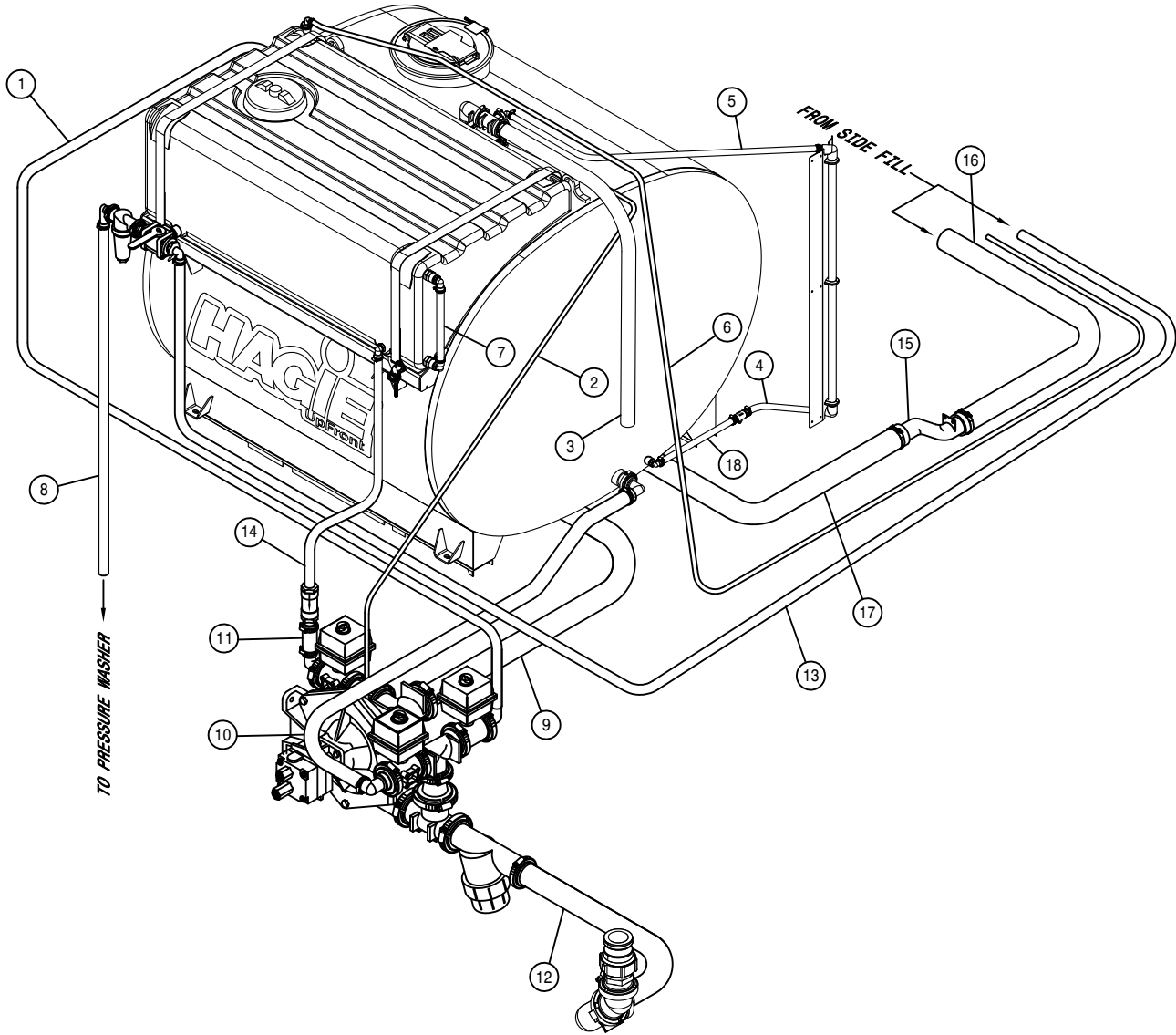

SIDE FILL SOLUTION HOISING (STD-VOLUME)

DET.	QTY	PART NO.	DESCRIPTION
	1	601704	HOSE, 1 X 140 1BR BLK EPDM
	2	601674	HOSE, 1/4 X 120 1 BR BLK EPDM
	3	601743	HOSE, 2 X 113 2F-1W EPDM
	4	601766	HOSE, 3/4 X 4 CLEAR VINYL
	5	601728	HOSE, 3/4 X 60 CLEAR VINYL
	6	601676	HOSE, 1/2 X 270 1BR BLK EPDM
	7	601742	HOSE, 1" X 16 CLEAR VINYL
	8	601522	HOSE, 1 X 204 1BR BLK EPDM
	9	601573	HOSE, 2 X 48 2F-1W EPDM
	10	601591	HOSE, 1 1/2 X 53 2BR BLK EPDM
	11	601590	HOSE, 1 X 6 1BR BLK EPDM
	12	601628	HOSE, 2 X 51 2F-1W EPDM
	13	601318	HOSE, 1 X 254 1BR BLK EPDM
	14	601492	HOSE, 1 X 37 1BR BLK EPDM
	15	690731	SOLU TUBE, 3.00 S.S. SIDE FILL
	16	601664	HOSE, 3 X 55 POLY HELIX EPDM
	17	601574	HOSE, 3 X 36 POLY HELIX EPDM
	18	601767	HOSE, 3/4 X 16 CLEAR VINYL

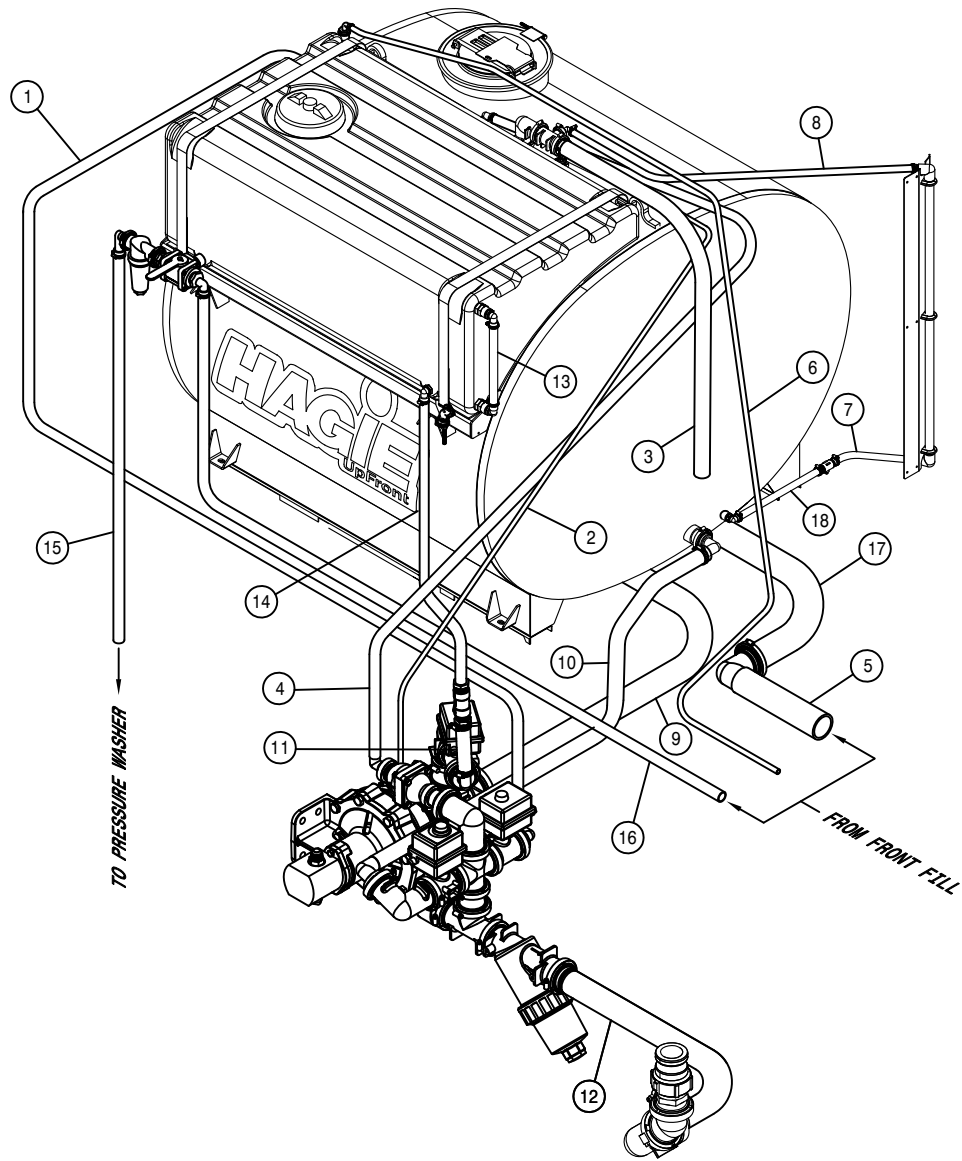

FRONT FILL SOLUTION TANK HOSEING (HI-VOLUME)

DET. QTY PART NO. DESCRIPTION

1	1	601704	HOSE, 1 X 140 1BR BLK EPDM
2	1	601674	HOSE, 1/4 X 120 1 BR BLK EPDM
3	1	601743	HOSE, 2 X 113 2F-1W EPDM
4	1	601682	HOSE, 1 X 111 2BR BLK EPDM
5	1	601680	HOSE, 3 X 91 POLY HELIX EPDM
6	1	601676	HOSE, 1/2 X 270 1BR BLK EPDM
7	1	601766	HOSE, 3/4 X 4 CLEAR VINYL
8	1	601728	HOSE, 3/4 X 60 CLEAR VINYL
9	1	601663	HOSE, 3 X 50 POLY HELIX EPDM
10	1	601591	HOSE, 1 1/2 X 53 2BR BLK EPDM
11	1	601590	HOSE, 1 X 6 1BR BLK EPDM
12	1	601628	HOSE, 2 X 51 2F-1W EPDM
13	1	601742	HOSE, 1" X 16 CLEAR VINYL
14	1	601492	HOSE, 1 X 37 1BR BLK EPDM
15	1	601522	HOSE, 1 X 204 1BR BLK EPDM
16	1	601497	HOSE, 1 X 206 1BR BLK EPDM
17	1	601508	HOSE, 3 X 64 POLY HELIX EPDM
18	1	601767	HOSE, 3/4 X 16 CLEAR VINYL

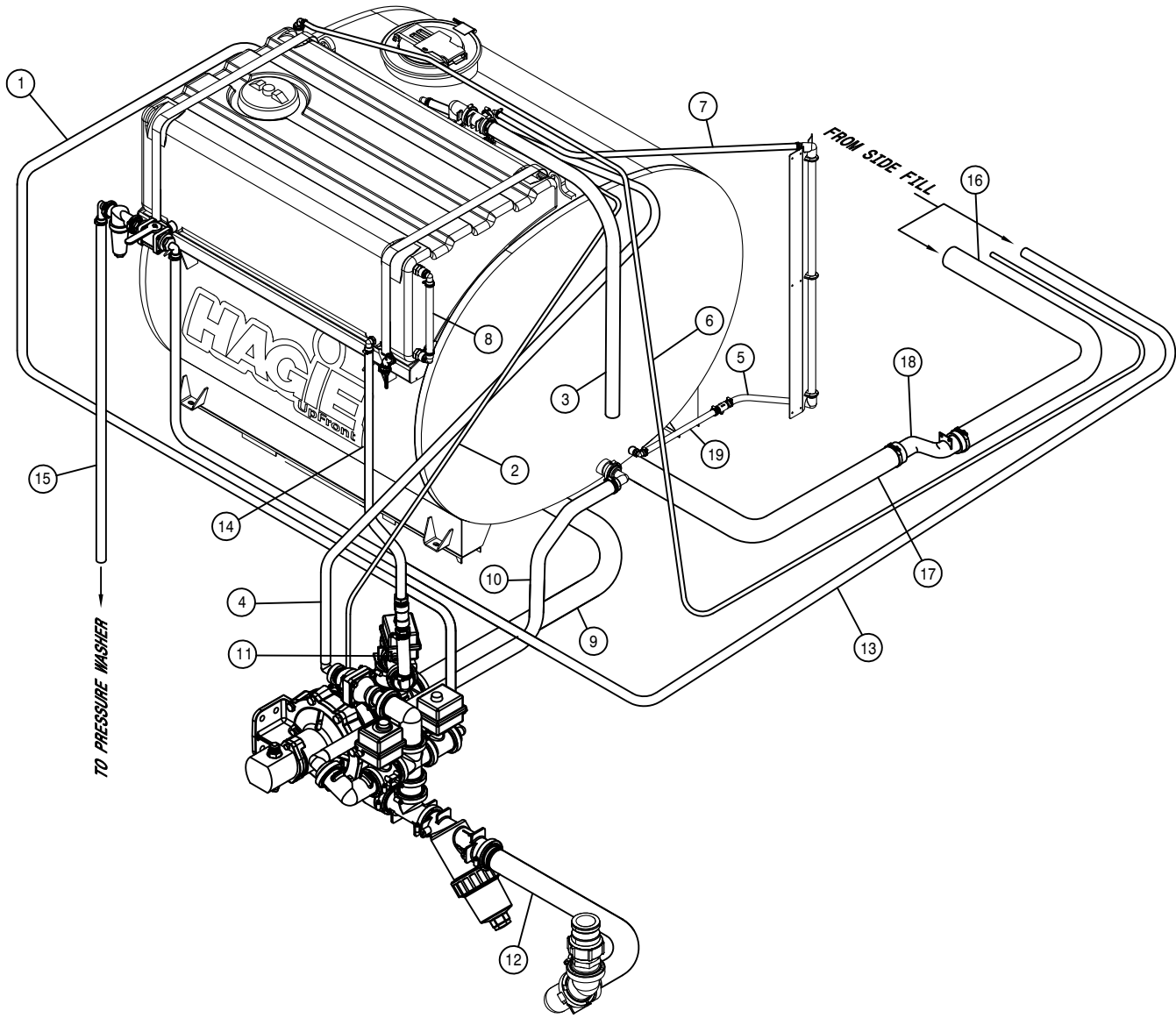

SIDE FILL SOLUTION HOSEING (HI-VOLUME)

DET.	QTY	PART NO.	DESCRIPTION
1	1	601704	HOSE, 1 X 140 1BR BLK EPDM
2	1	601674	HOSE, 1/4 X 120 1 BR BLK EPDM
3	1	601743	HOSE, 2 X 113 2F-1W EPDM
4	1	601682	HOSE, 1 X 111 2BR BLK EPDM
5	1	601766	HOSE, 3/4 X 4 CLEAR VINYL
6	1	601676	HOSE, 1/2 X 270 1BR BLK EPDM
7	1	601728	HOSE, 3/4 X 60 CLEAR VINYL
8	1	601742	HOSE, 1" X 16 CLEAR VINYL
9	1	601663	HOSE, 3 X 50 POLY HELIX EPDM
10	1	601591	HOSE, 1 1/2 X 53 2BR BLK EPDM
11	1	601590	HOSE, 1 X 6 1BR BLK EPDM
12	1	601628	HOSE, 2 X 51 2F-1W EPDM
13	1	601318	HOSE, 1 X 254 1BR BLK EPDM
14	1	601492	HOSE, 1 X 37 1BR BLK EPDM
15	1	601522	HOSE, 1 X 204 1BR BLK EPDM
16	1	601664	HOSE, 3 X 55 POLY HELIX EPDM
17	1	601574	HOSE, 3 X 36 POLY HELIX EPDM
18	1	690731	SOLU TUBE, 3.00 S.S. SIDE FILL
19	1	601767	HOSE, 3/4 X 16 CLEAR VINYL

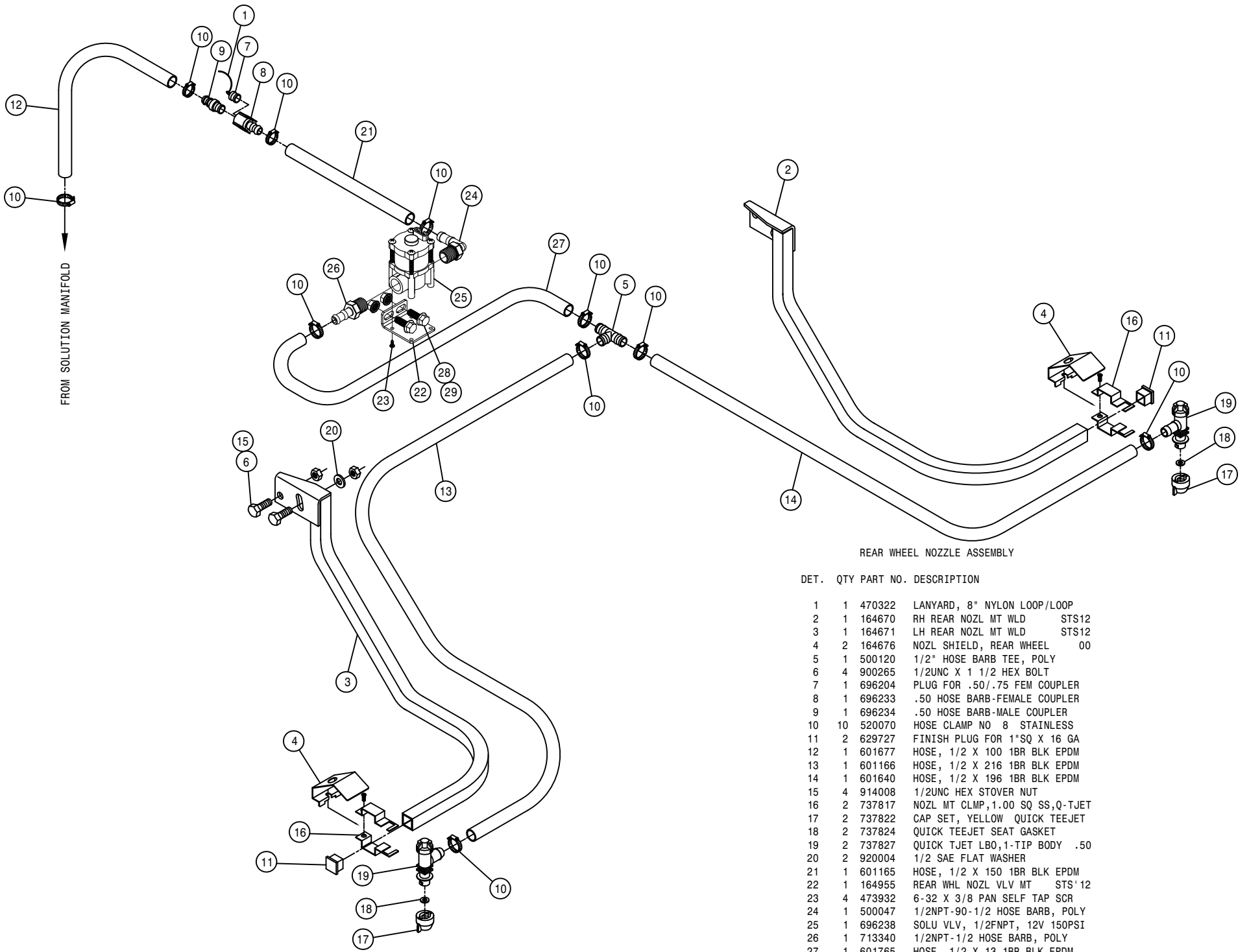

REAR WHEEL NOZZLE ASSEMBLY

DET. QTY PART NO. DESCRIPTION

DET.	QTY	PART NO.	DESCRIPTION
1	1	470322	LANYARD, 8" NYLON LOOP/LOOP
2	1	164670	RH REAR NOZL MT WLD STS12
3	1	164671	LH REAR NOZL MT WLD STS12
4	2	164676	NOZL SHIELD, REAR WHEEL 00
5	1	500120	1/2" HOSE BARB TEE, POLY
6	4	900265	1/2UNC X 1 1/2 HEX BOLT
7	1	696204	PLUG FOR .50/.75 FEM COUPLER
8	1	696233	.50 HOSE BARB-FEMALE COUPLER
9	1	696234	.50 HOSE BARB-MALE COUPLER
10	10	520070	HOSE CLAMP NO 8 STAINLESS
11	2	629727	FINISH PLUG FOR 1"SQ X 16 GA
12	1	601677	HOSE, 1/2 X 100 1BR BLK EPDM
13	1	601166	HOSE, 1/2 X 216 1BR BLK EPDM
14	1	601640	HOSE, 1/2 X 196 1BR BLK EPDM
15	4	914008	1/2UNC HEX STOVER NUT
16	2	737817	NOZL MT CLMP,1.00 SQ SS,Q-TJET
17	2	737822	CAP SET, YELLOW QUICK TEEJET
18	2	737824	QUICK TEEJET SEAT GASKET
19	2	737827	QUICK TJET LBO,1-TIP BODY .50
20	2	920004	1/2 SAE FLAT WASHER
21	1	601165	HOSE, 1/2 X 150 1BR BLK EPDM
22	1	164955	REAR WHL NOZL VLV MT STS'12
23	4	473932	6-32 X 3/8 PAN SELF TAP SCR
24	1	500047	1/2NPT-90-1/2 HOSE BARB, POLY
25	1	696238	SOLU VLV, 1/2FNPT, 12V 150PSI
26	1	713340	1/2NPT-1/2 HOSE BARB, POLY
27	1	601765	HOSE, 1/2 X 13 1BR BLK EPDM
28	2	900128	3/8UNC X 3/4 HEX BOLT
29	2	470087	3/8UNC HEX FLANGE LOCK NUT

DET. QTY PART NO. DESCRIPTION

DET.	QTY	PART NO.	DESCRIPTION
1	2	500074	1"NPT-1" HOSE BARB, POLY
2	1	500103	1/8NPT-90-1/4 HOSE BARB, NYLON
3	1	500151	2" FLANGE TEE POLY
4	1	500154	2" FLANGE-2" HOSE BARB POLY
5	9	500158	1 1/2" GASKET FOR 2" FLANGE
6	12	500160	2" FLANGE CLAMP, S.S.
7	1	500172	2" FLANGE-1" HOSE BARB POLY
8	3	500180	2" FLANGE-90-2" FLANGE LBO, LONG
9	1	500189	2" FLANGE-90-1" HOSE BARB POLY
10	6	500194	2"FP FLANGE CLAMP, S.S.
11	6	500195	2"FP FLANGE GASKET EPDM
12	1	500196	2"FP FLANGE-2" HOSE BARB POLY
13	3	500199	2"FP FLANGE-2" FLANGE REDU POLY
14	2	500207	2"FP FLANGE TEE POLY
15	4	520090	HOSE CLAMP NO 16 STAINLESS
16	1	601590	HOSE, 1 X 6 1BR BLK EPDM
17	2	618191	1 1/16MJ-90-1 1/16FJ SWIV LBO
18	1	618273	1 1/16MJIC-1/2INPT ADPTR
19	1	650125	DECAL, AGIT RATE IND, KZCO VLV
20	1	690488	1.00 CHECK VLV, SPRING LOADED
21	1	690628	LINE "Y" STRAINER, 2" FLANGE
22	1	690629	50 MESH SCREEN FOR 690628
23	1	691160	HYPRO PUMP, 9306C-HMSC-BU, FLG
24	3	696254	O-RING, KZCO FLANGED VALVES
25	2	696256	VALVE, KZCO C2F-60B-M-S9
26	1	696257	VALVE, KZCO C2F-62-0-S9
27	1	500153	2" FLANGE-90-1 1/2 HBARB POLY
28	1	520067	HOSE CLAMP NO 28 STAINLESS
29	2	520141	2.31/2.62 T-BOLT HOSE CLAMP SS
30	1	520120	HOSE CLAMP NO 4 STAINLESS
31	2	900131	3/8UNC X 1 1/2 HEX BOLT
32	2	914004	3/8UNC HEX STOVER NUT
33	1	690944	SEAL KIT, SILICON HYPRO 690906
34	1	292500	PWM AMPLIFIER, 12V
35	2	472235	10-32 X 3/4 PHIL PAN MACH SCR
36	2	470175	10-32 HEX FLANGE LOCK NUT
37	1	618108	1 1/16MJIC-3/4INPT ADPTR

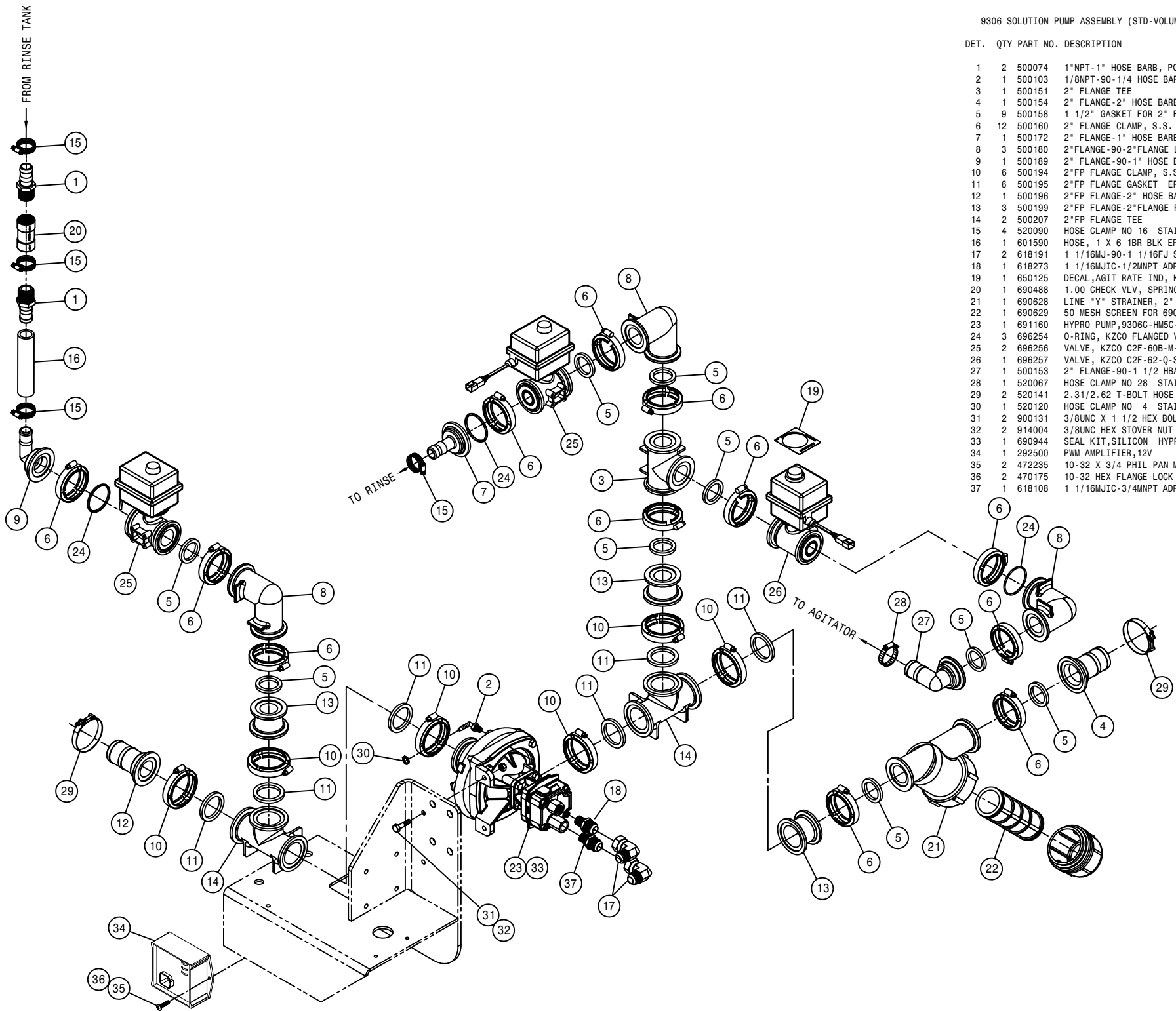

DET. QTY PART NO. DESCRIPTION

1	2	500074	1"NPT-1" HOSE BARB, POLY
2	1	500104	1/4NPT-90-1/4 HOSE BARB, POLY
3	2	500157	1" FLANGE GASKET EPDM
4	8	500158	1 1/2" GASKET FOR 2" FLANGE
5	2	500159	1" FLANGE CLAMP, S.S.
6	11	500160	2" FLANGE CLAMP, S.S.
7	1	500161	2"FLANGE-1"FLANGE COUPLER,POLY
8	1	500173	1" FLANGE-90-1" HOSE BARB POLY
9	1	500176	2" FLANGE CROSS POLY
10	3	500180	2"FLANGE-90-2"FLANGE LBO, LONG
11	2	500189	2" FLANGE-90-1" HOSE BARB POLY
12	4	500194	2"FP FLANGE CLAMP, S.S.
13	4	500195	2"FP FLANGE GASKET EPDM
14	1	500196	2"FP FLANGE-2" HOSE BARB POLY
15	1	500199	2"FP FLANGE-2"FLANGE REDU POLY
16	1	500205	2"FP FLANGE-2"MNPT ADPTR S.S.
17	1	500207	2"FP FLANGE TEE POLY
18	3	500208	3" FLANGE CLAMP, S.S.
19	3	500209	3" FLANGE GASKET EPDM
20	1	500210	3" FLANGE-3" HOSE BARB POLY
21	1	500217	3" FLANGE TEE POLY
22	1	500234	3"FP FLANGE-3"MNPT ADPTR S.S.
23	1	500237	3"FLANGE-2"FLANGE REDU POLY
24	5	520090	HOSE CLAMP NO 16 STAINLESS
25	1	601590	HOSE, 1 X 6 1BR BLK EPDM
26	1	650125	DECAL,AGIT RATE IND, KZCO VLV
27	1	690488	1.00 CHECK VLV, SPRING LOADED
28	1	691036	HYPRO 9307C-GM10 PUMP
29	1	696006	LINE "Y" STRAINER,2"FP FLG 50M
30	1	696008	PRESS RELIEF VLV,100PSI,1"FLG
31	3	696254	O-RING, KZCO FLANGED VALVES
32	2	696256	VALVE, KZCO C2F-60B-M-S9
33	1	696257	VALVE, KZCO C2F-62-Q-S9
34	1	611128	7/8MJIC-90-7/8MOR LBO
35	1	611127	1 1/16MJIC-1 1/16MOR ADPTR
36	1	500153	2" FLANGE-90-1 1/2 HBARB POLY
37	4	900334	5/8UNC X 1 3/4 HEX BOLT
38	4	914010	5/8UNC HEX STOVER NUT
39	1	520120	HOSE CLAMP NO 4 STAINLESS
40	1	520141	2.31/2.62 T-BOLT HOSE CLAMP SS
41	1	520145	3.56/3.88 T-BOLT HOSE CLAMP SS
42	1	520067	HOSE CLAMP NO 28 STAINLESS
43	1	691068	MECHANICAL SEAL KIT FOR 691036
44	1	691069	BEARING KIT FOR 691036
45	1	691070	IMPELLER HDWE KIT FOR 691036
46	1	691071	HYD MOTOR SEAL FOR 691036
47	1	691072	HYD MOTOR (GM10) FOR 691036
48	1	691073	SHAFT ASSEMBLY FOR 691036
49	1	691074	SEAL FLANGE FOR 691036
50	1	691075	IMPELLER FOR 691036
51	1	691076	O-RING,FLANGE FOR 691036
52	1	696007	50 MESH SCREEN FOR 696006
53	1	696009	80 MESH SCREEN FOR 696006
54	1	292500	PWM AMPLIFIER,12V
55	2	472235	10-32 X 3/4 PHIL PAN MACH SCR
56	2	470175	10-32 HEX FLANGE LOCK NUT

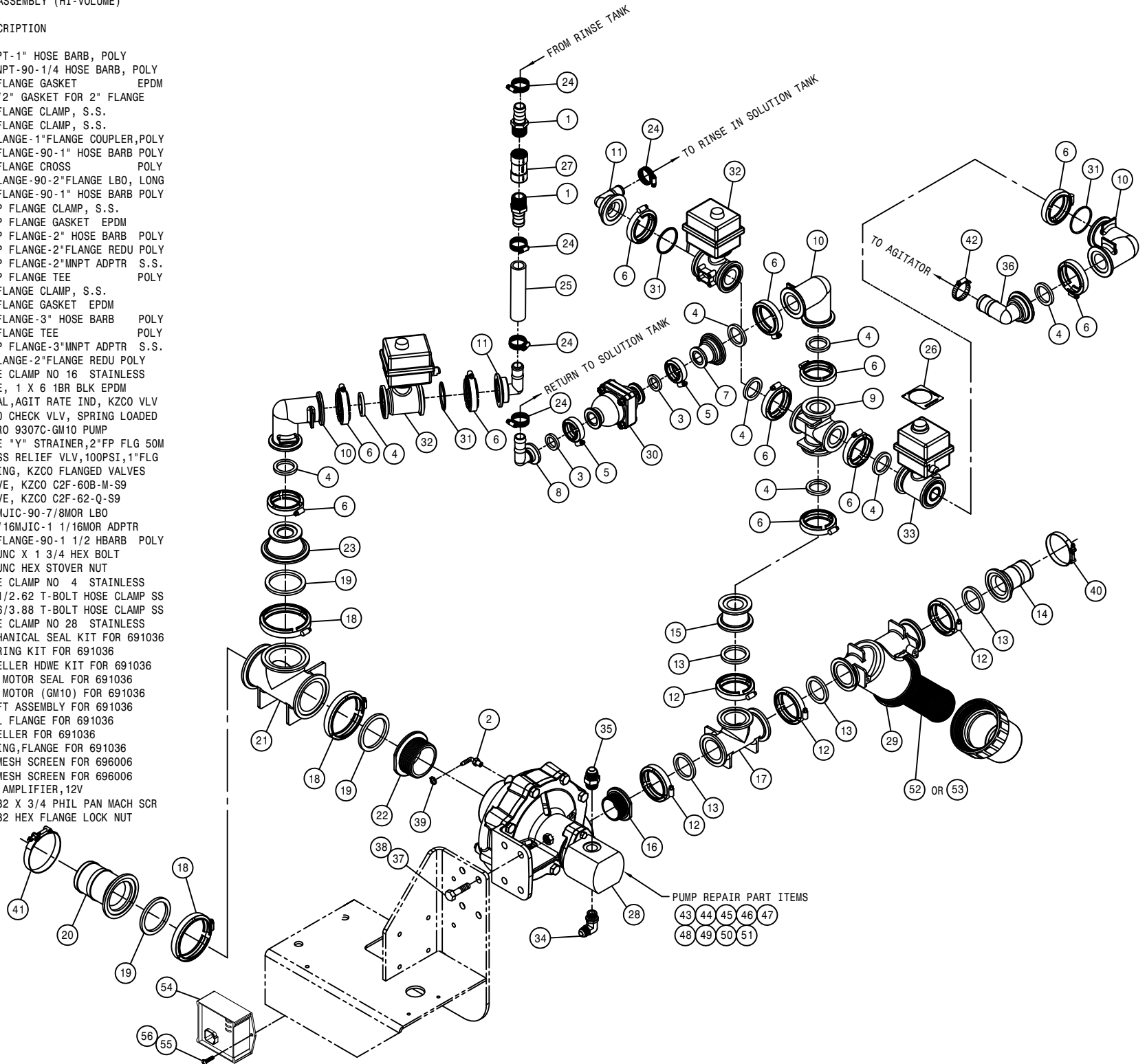

QUICK ATTACH LEVER ASSEMBLY

DET. QTY PART NO. DESCRIPTION

1	1	361742	MAINFRAME WLD STS 10/12	07
2	1	361665	RH Q-ATTACH LOCK WLD, STS	04
3	1	361666	LH Q-ATTACH LOCK WLD, STS	04
4	1	361670	RH Q-ATTACH LOCK PIN WLD, STS04	
5	1	361671	LH Q-ATTACH LOCK PIN WLD, STS04	
6	2	473805	ROLL PIN, 1/4 X 1 1/2	
7	2	482018	SPRING, 1.00 X 12.00 COMPRSN	
8	2	483055	.771ID-1.2500D-.135T MACH WASH	
9	2	629765	CAPPLUGS PLUG, 1 1/2"RD, BLK POLY	
10	4	900130	3/8UNC X 1 1/4 SER FLANGE BOLT	
11	4	914004	3/8UNC HEX STOVER NUT	
12	4	920002	3/8 SAE FLAT WASHER	
13	2	473850	ROLL PIN, 1/4 X 1"	

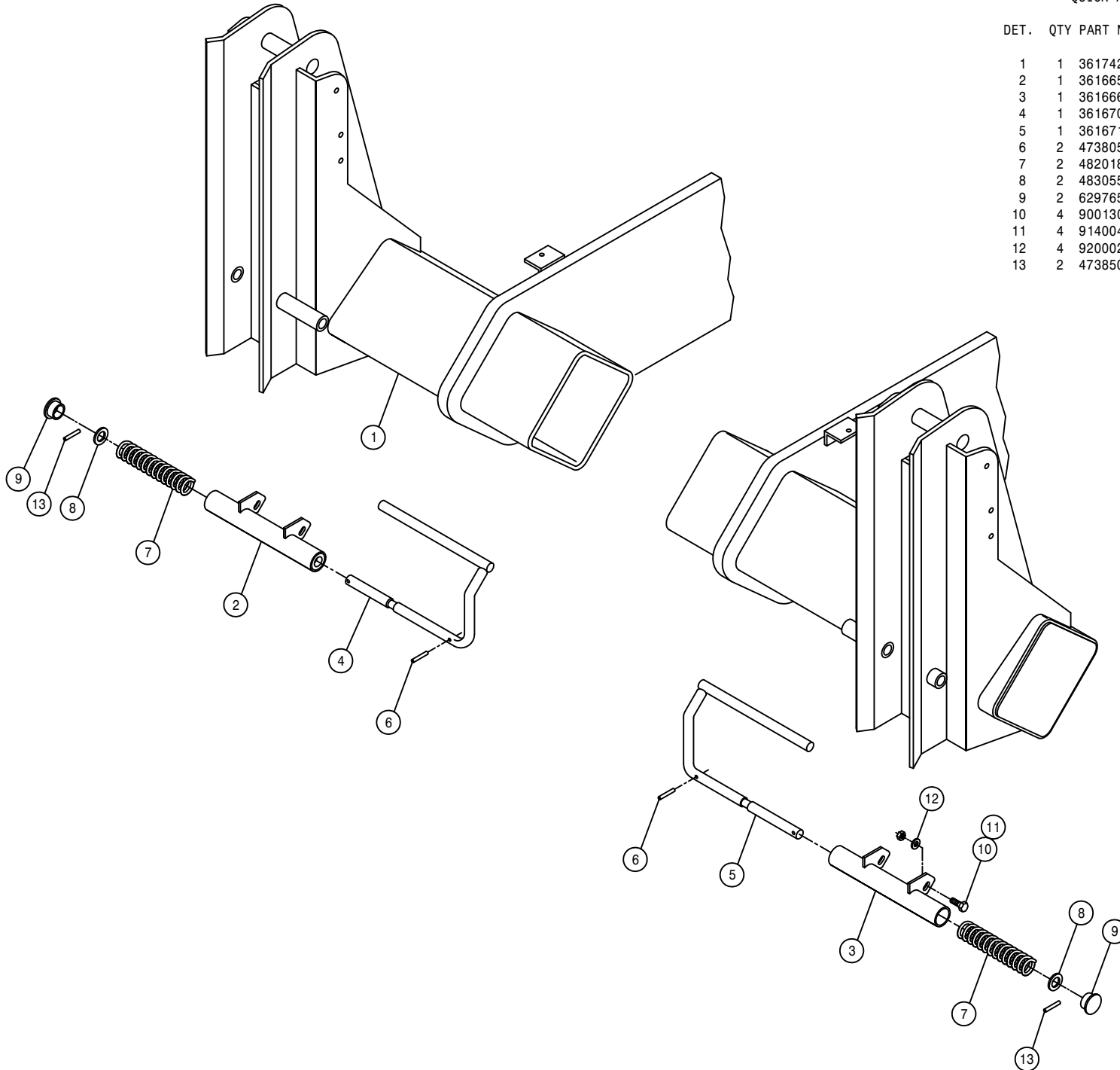

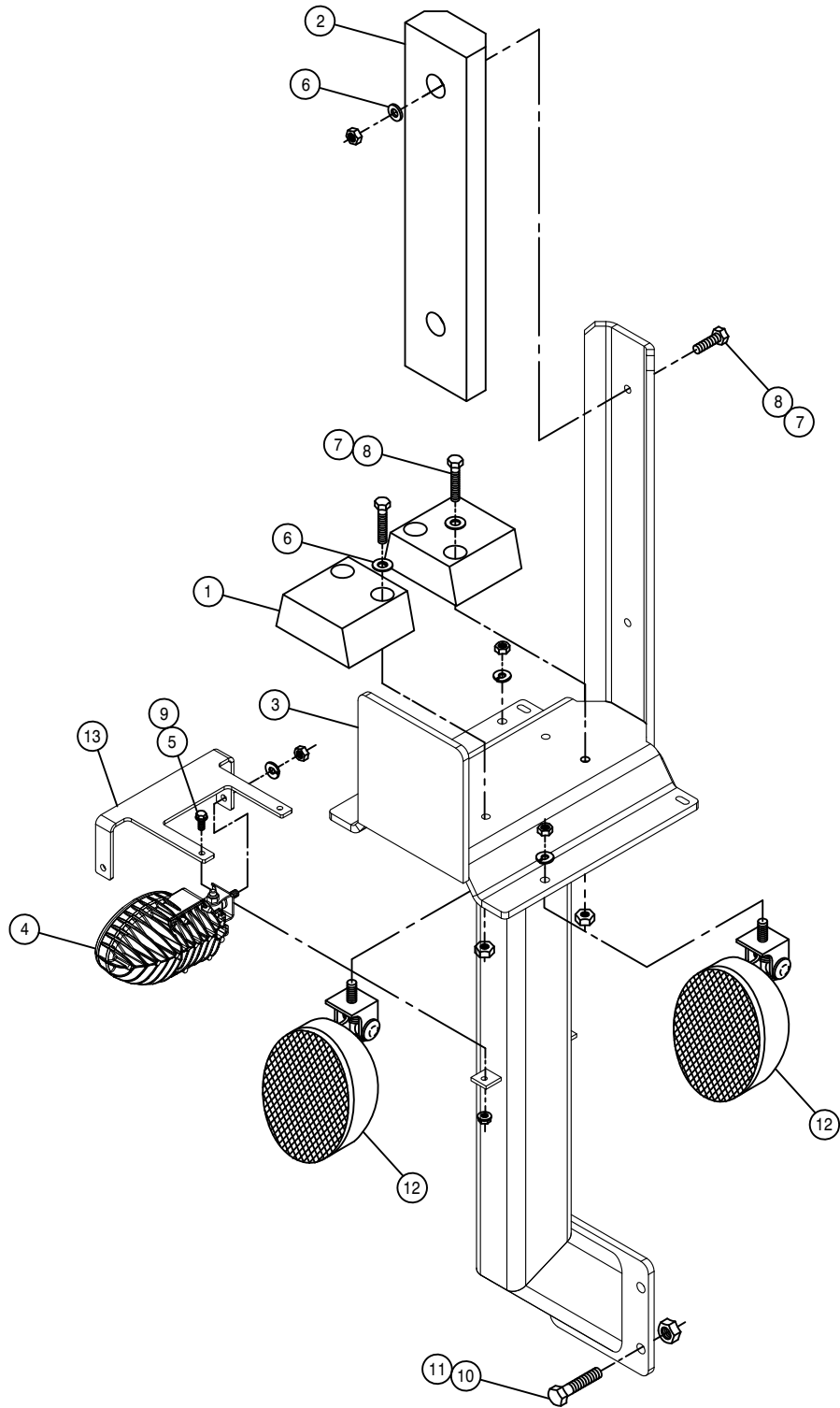

RH BOOM CRADLE ASSEMBLY

DET.	QTY	PART NO.	DESCRIPTION		
	1	2	164513	BOOM CRADLE PAD	00
	2	1	164512	RUBBER BUMPER, BOOM CRADLE	00
	3	1	165041	BOOM CRADLE WLD	07
	4	1	292917	LED LIGHT, AMBER W/JUMPER	
	5	2	470118	1/4UNC X 3/4 FLANGE HEX BOLT	
	6	6	920002	3/8 SAE FLAT WASHER	
	7	6	914004	3/8UNC HEX STOVER NUT	
	8	6	900133	3/8UNC X 2" SERR FLANGE BOLT	
	9	2	470121	1/4UNC HEX FLANGE LOCK NUT	
	10	4	900804	1/2UNC X 1 1/2 HEX BOLT GR8	
	11	4	914808	1/2UNC HEX STOVER NUT GR8	
	12	2	291904	WORKLIGHT, VERTICAL FLOOD PLAS	
	13	1	343689	EXTREMITY FLASHER MT, STS '11	

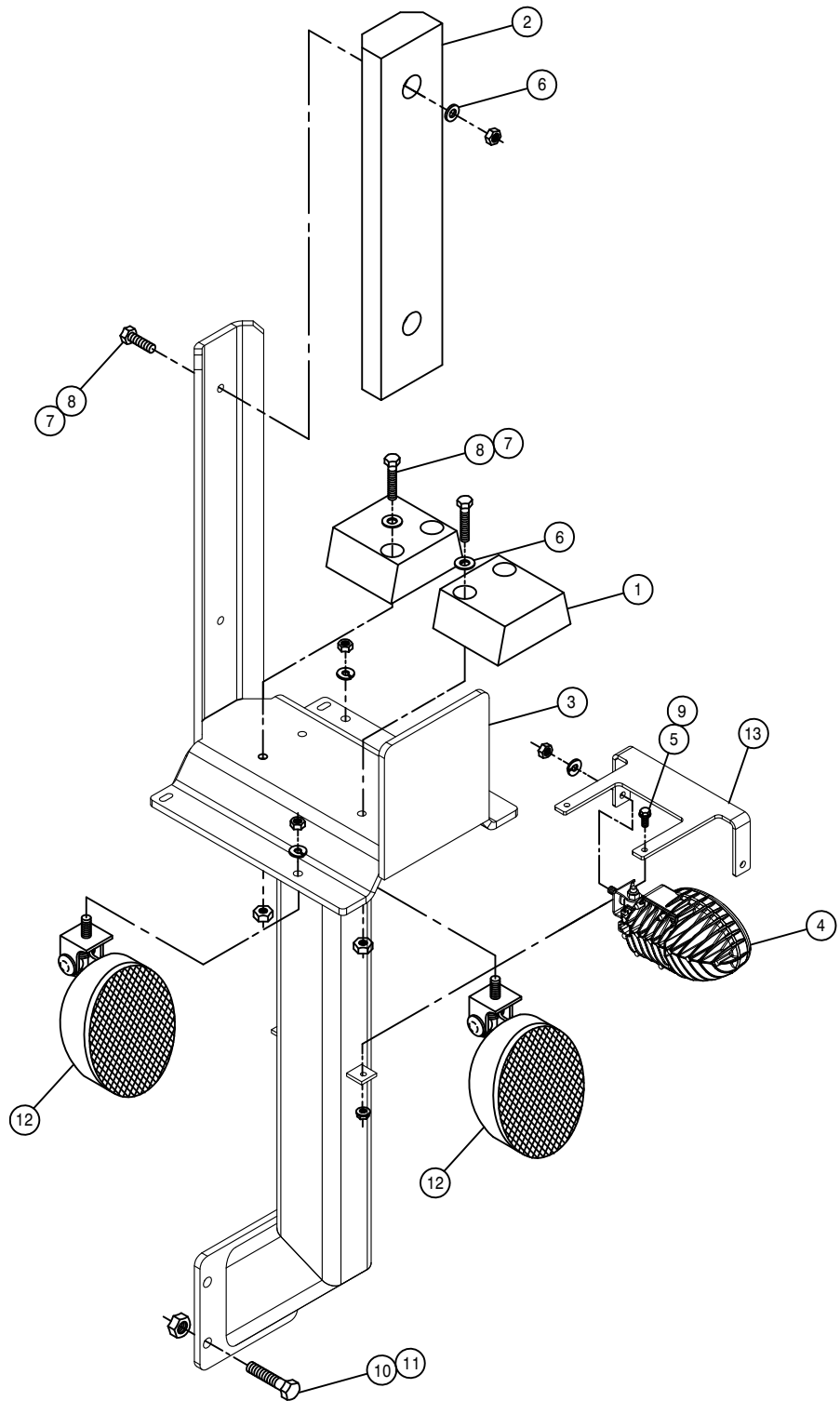

LH BOOM CRADLE ASSEMBLY

DET.	QTY	PART NO.	DESCRIPTION		
	1	2	164513	BOOM CRADLE PAD	00
	2	1	164512	RUBBER BUMPER, BOOM CRADLE	00
	3	1	165041	BOOM CRADLE WLD	07
	4	1	292917	LED LIGHT, AMBER W/JUMPER	
	5	2	470118	1/4UNC X 3/4 FLANGE HEX BOLT	
	6	6	920002	3/8 SAE FLAT WASHER	
	7	6	914004	3/8UNC HEX STOVER NUT	
	8	6	900133	3/8UNC X 2" SERR FLANGE BOLT	
	9	2	470121	1/4UNC HEX FLANGE LOCK NUT	
	10	4	900804	1/2UNC X 1 1/2 HEX BOLT GR8	
	11	4	914808	1/2UNC HEX STOVER NUT GR8	
	12	2	291904	WORKLIGHT, VERTICAL FLOOD PLAS	
	13	1	343689	EXTREMITY FLASHER MT, STS '11	

FOAMER TANK ASSEMBLY

DET.	QTY	PART NO.	DESCRIPTION
	1	2	195908 HOSE 3/4ID-1/8W CLEAR VINYL X 206.00
	2	1	601624 HOSE, 3/8 X 60 AIR
	3	2	696181 3/4" ELECT SOLU SOLE VALVE 02
	4	6	470294 RUBBER BUMPER, RECESS, .63H-1.5D
	5	2	696208 .75 HOSE BARB-MALE COUPLER
	6	1	505205 BLK PIPE NIPPLE 1.00NPT-5.00
	7	1	505211 3/8-1/4NPT REDU BUSH, BRS
	8	3	520120 HOSE CLAMP NO 4 STAINLESS
	9	6	520055 HOSE CLAMP NO 12 STAINLESS
	10	1	601419 HOSE, 3/8 X 30 CLEAR VINYL
	11	1	601420 HOSE, 3/8 X 48 CLEAR VINYL
	12	1	618571 1/4MNPT-90-1/4MNPT LBO
	13	1	695900 BALL VALVE 1IN FNPT POLY
	14	1	696120 BALL VALVE, 1/4NPT, STEEL
	15	1	696134 BALL VALVE 2IN FNPT POLY
	16	2	500043 3/4NPT PIPE PLUG, POLY
	17	1	701112 FOAM MARKER TANK, 36 GAL SS
	18	2	701214 1/2NPT-90-3/4HBARB,1/4TAP,POLY
	19	2	701215 1/4PIPE PLUG, .187 ORIFICE,POLY
	20	1	711051 1/4FNPT-3/8 NYL TUBE, SNGL
	21	2	696207 .75 HOSE BARB-FEMALE COUPLER
	22	1	783304 1/4 NPT X 3/8 HOSE BARB, BRS
	23	6	900064 5/16UNC X 3/4 HEX BOLT
	24	6	914002 5/16UNC HEX STOVER NUT
	25	7	914008 1/2UNC HEX STOVER NUT
	26	3	900264 1/2UNC X 1 1/4 HEX BOLT
	27	1	701257 FMR TANK MT WELD STS 07
	28	2	701170 FOAMER TANK STRAP ASSY
	29	1	701144 FOAMER AIR NOZZLE
	30	1	500223 SS PIPE CPLG, 1/8NPT
	31	1	507021 SS PIPE NIPPLE, 1/8NPT X 6"
	32	1	701143 FOAMER AIR TUBE FTG
	33	1	507728 REDU BUSH 1/2MNPT X 1/4FNPT,SS
	34	2	500079 3/4NPT-90 EL, POLY
	35	1	701269 LH FMR TANK SUPP CHAN, LG STS07
	36	1	701270 FMR TANK CROSS BRACE STS 07
	37	7	470460 3/8UNC X 1 SERR FLANGE BOLT
	38	7	470087 3/8UNC HEX FLANGE LOCK NUT

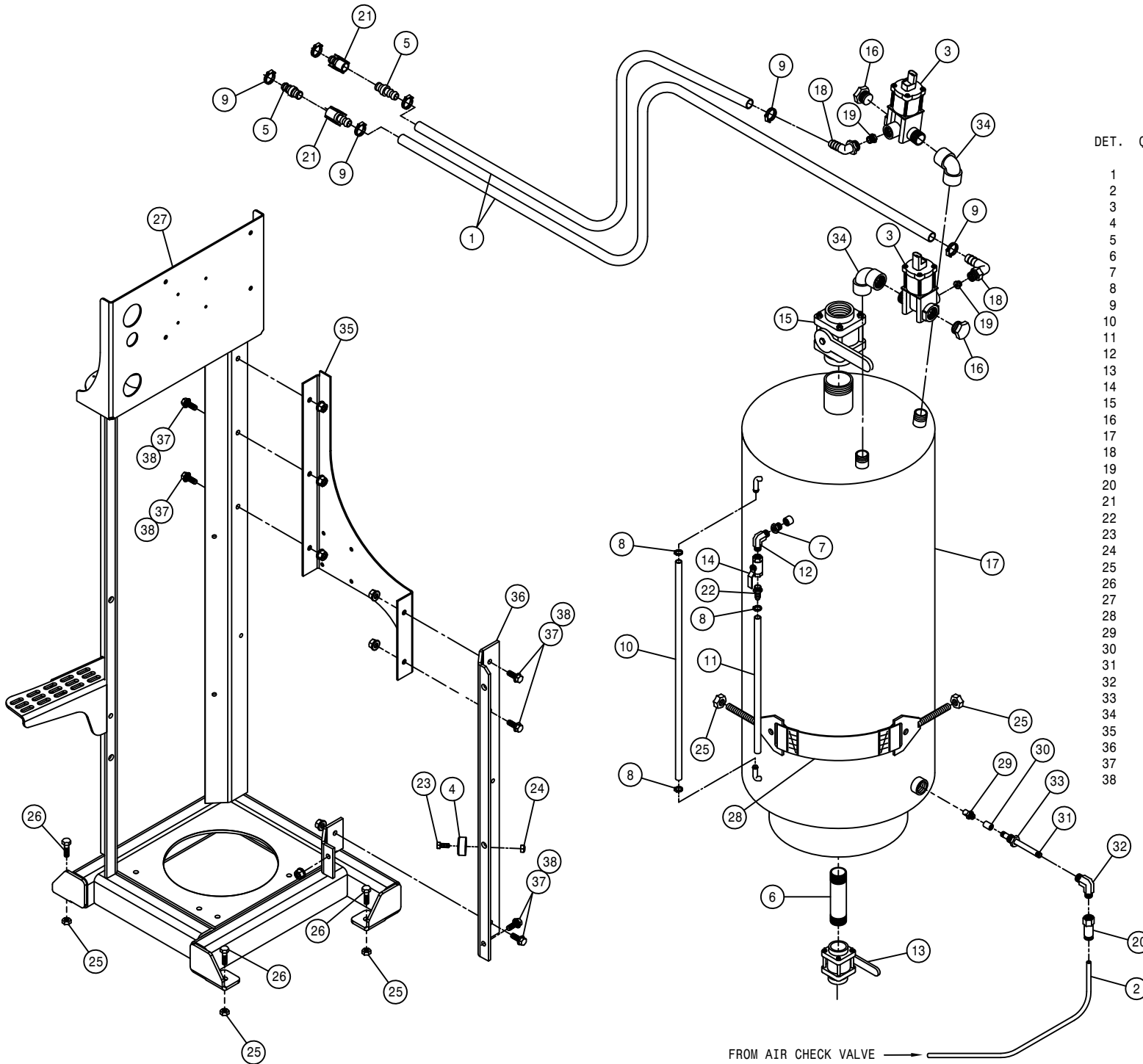

FROM AIR CHECK VALVE →

FRESH WATER TANK ASSEMBLY

DET. QTY PART NO. DESCRIPTION

1	1	470318	RINSE TANK, 3 GAL SQ W/LID
2	1	500019	3/4NPT-1/2HOSE BARB, POLY
3	1	500047	1/2NPT-90-1/2 HOSE BARB, POLY
4	2	520070	HOSE CLAMP NO 8 STAINLESS
5	1	601489	HOSE, 1/2 X 72 CLEAR VINYL
6	1	696082	BALL VALVE 1/2FNPT POLY
7	1	713340	1/2NPT-1/2 HOSE BARB, POLY
8	4	900064	5/16UNC X 3/4 HEX BOLT
9	2	903853	6-32X1 1/4 PHIL PN MACH SCR,SS
10	2	910022	6-32 HEX NUT
11	4	920501	5/16 LOCK WASHER
12	1	701257	FMR TANK MT WELD STS 07
13	2	920512	# 6 LOCK WASHER
14	1	470337	6" LID FOR 3 GAL TANK 470318
15	1	314901	FILTER MINDER AIR RESTRICT GA
16	1	701310	AIR PRESS GAUGE, 1/8"BOT
17	1	711019	1/4"MNPT AIR REGULATOR
18	1	711021	1 1/4-18 NUT,AIR REGULATOR MT
19	3	711043	1/4MNPT-90-3/8 NYL 1-TUBE LBO
20	1	601587	HOSE, 3/8 X 102 AIR
21	1	601624	HOSE, 3/8 X 60 AIR
22	1	601633	HOSE, 3/8 X 11 AIR
23	1	711051	1/4FNPT-3/8 NYL TUBE, SNGL
24	1	696235	1/4" ELECT SOLU SOLE VLV, 2203
25	1	711052	1/4"NPT CHECK VALVE,SWING,2600
26	1	618571	1/4MNPT-90-1/4MNPT LBO
27	1	195913	HOSE 7/64" WINDSHIELD WASHER

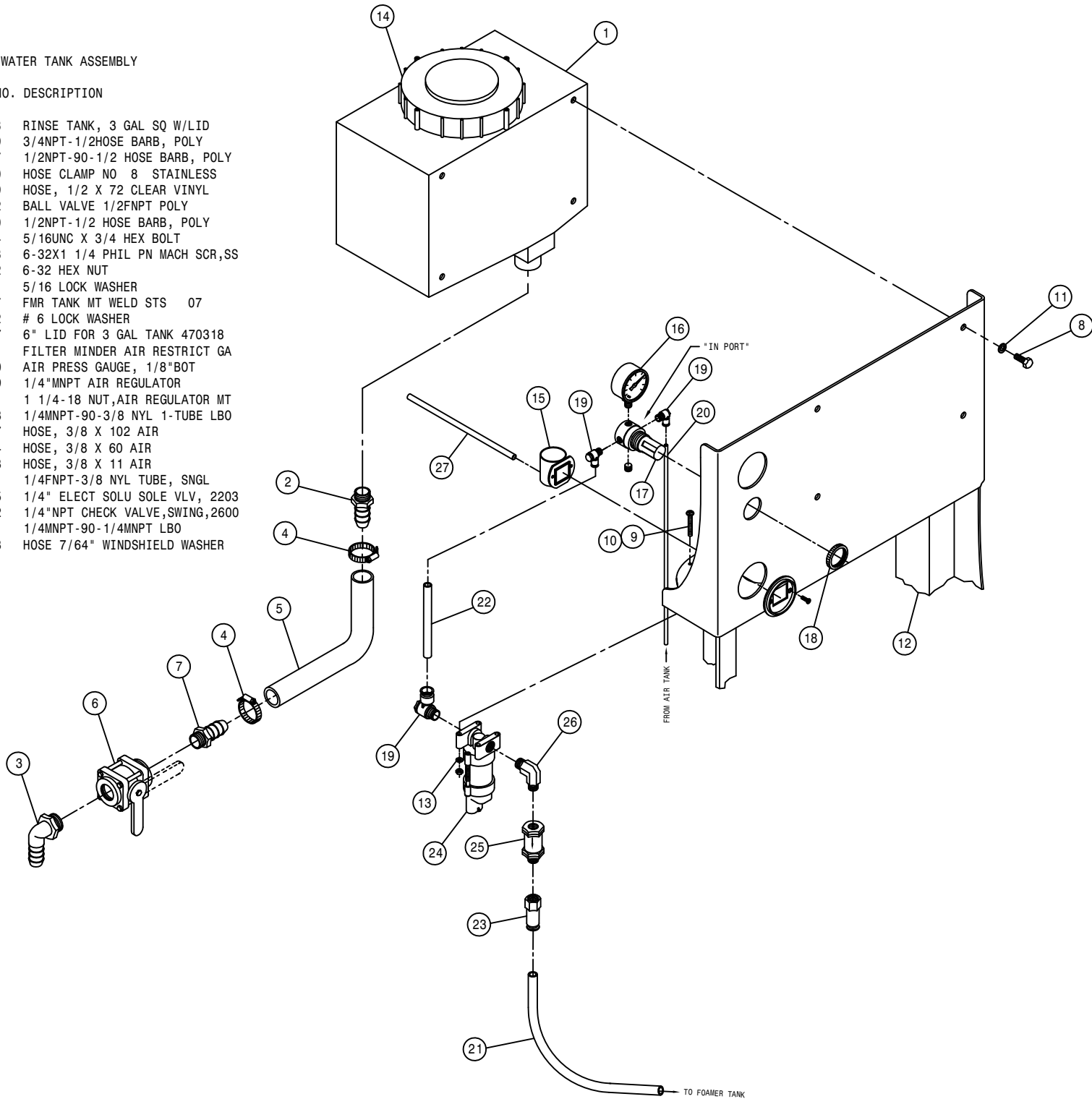

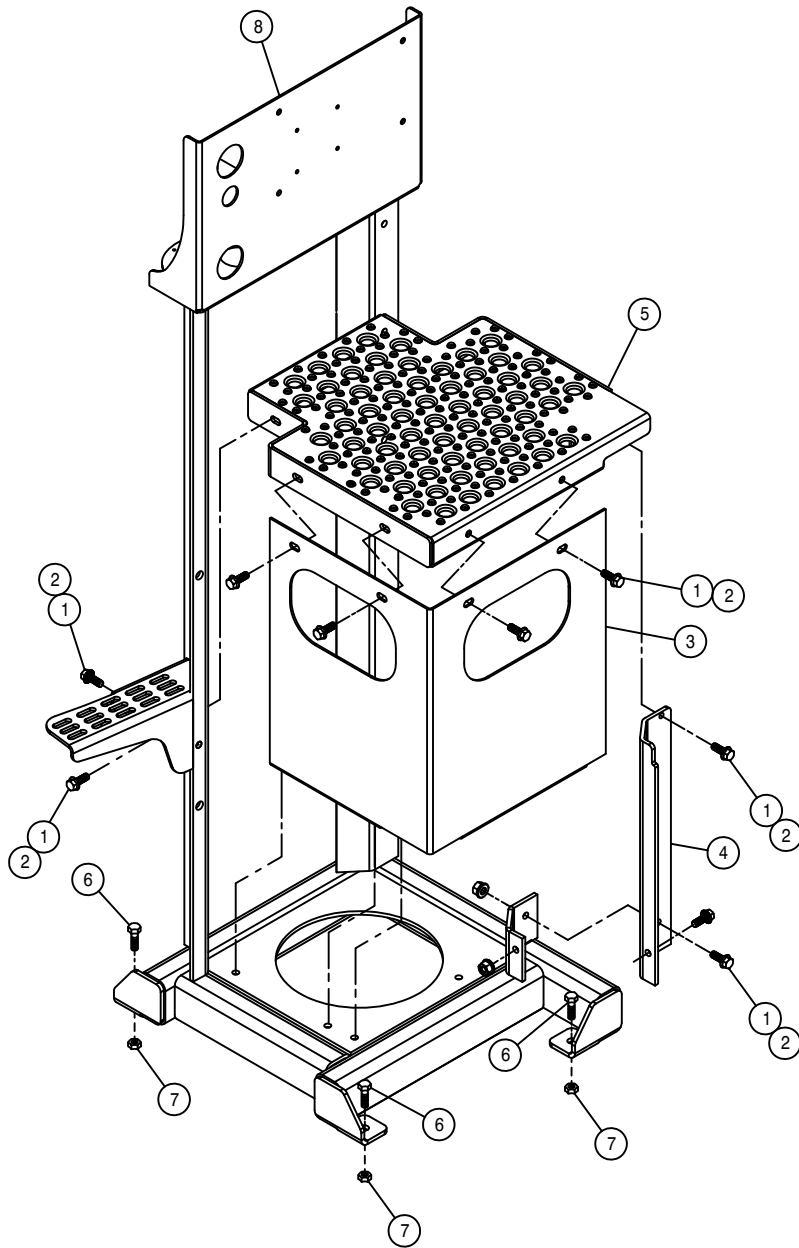

FRESH WATER TANK MT W/O FOAMER ASSEMBLY

DET. QTY PART NO. DESCRIPTION

1	12	470087	3/8UNC HEX FLANGE LOCK NUT
2	12	470460	3/8UNC X 1 SERR FLANGE BOLT
3	1	701268	FOAMER SERV PLTFRM WRAP
4	1	701263	LH FMR TANK SUPP CHAN STS 07
5	1	701264	FMR SERV PLATFRM WELD
6	3	900264	1/2UNC X 1 1/4 HEX BOLT
7	3	914008	1/2UNC HEX STOVER NUT
8	1	701257	FMR TANK MT WELD STS 07

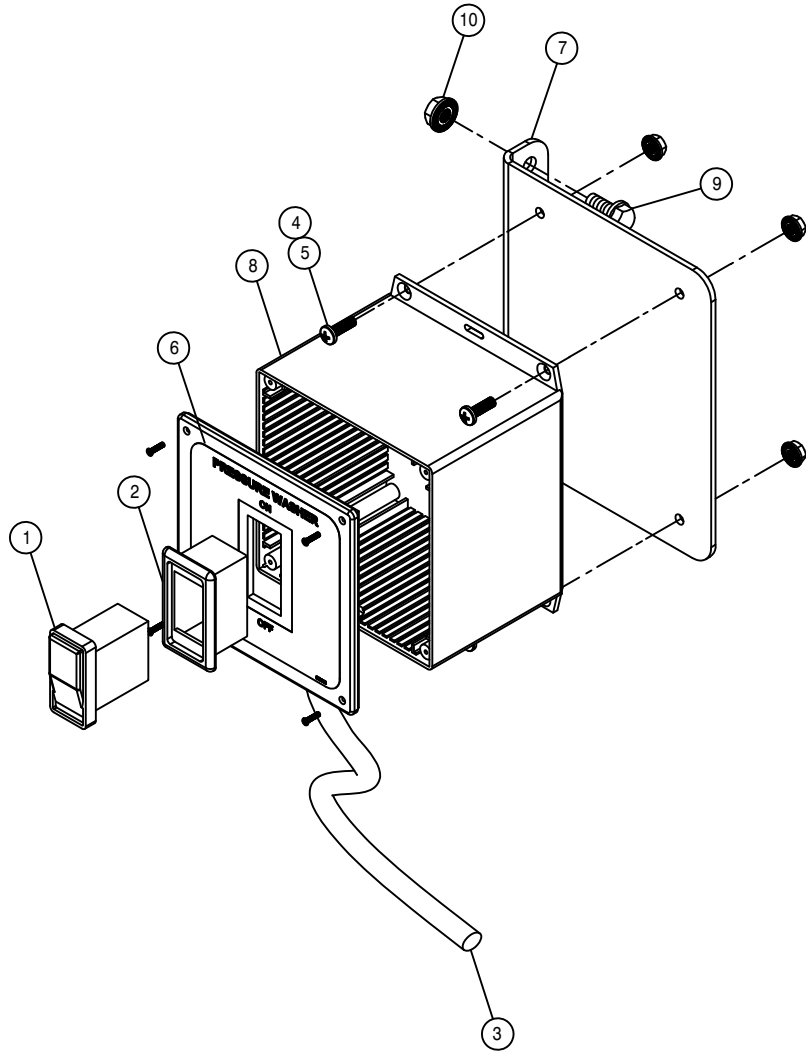

PRESSURE WASHER SWITCH BOX ASSEMBLY

DET. QTY PART NO. DESCRIPTION

1	1	292218	SWITCH,SIDE FILL PUMP/PRESWASH
2	1	292260	MOUNTING TRIM, SINGLE VMS
3	1	293878	PRESS WASH WIRE HARNESS STS 07
4	4	470175	10-32 HEX FLANGE LOCK NUT
5	4	903710	10-32X5/8 PHIL PANHD MACH SCR
6	1	650156	DECAL,PRESS WASH CTRL STS 05
7	1	691112	PRESS WASH SWITCH BX MT,STS 09
8	1	690975	PRESS WASH SWITCH BOX, STS 05
9	2	900064	5/16UNC X 3/4 HEX BOLT
10	2	470113	5/16UNC HEX FLANGE LOCK NUT

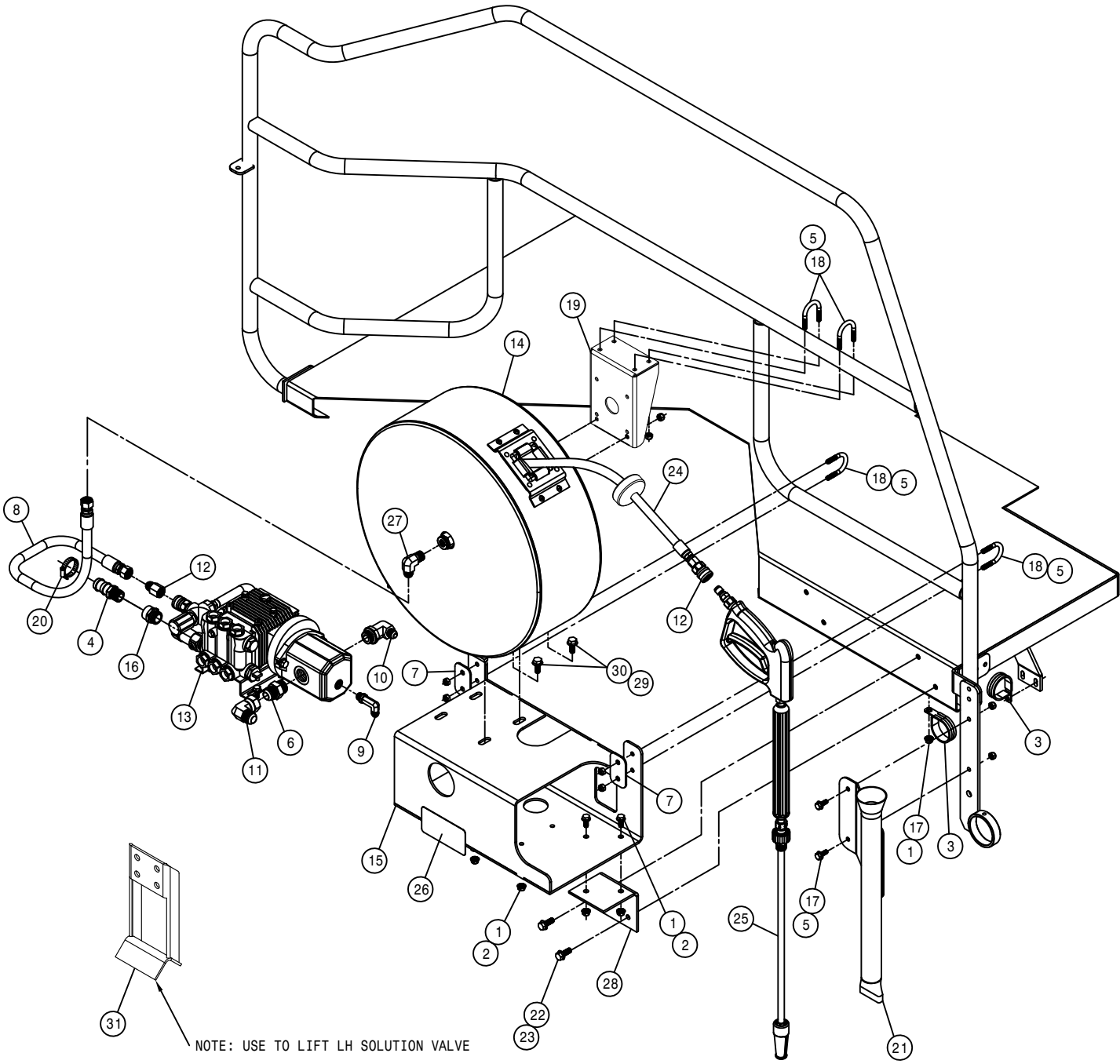

PRESSURE WASHER OPTION

DET.	QTY	PART NO.	DESCRIPTION
1	9	470113	5/16UNC HEX FLANGE LOCK NUT
2	8	470233	5/16UNC X 3/4 FLANGE HEX BOLT
3	2	520126	CUSH CLAMP,#32 2IN X 5/8W
4	1	500123	3/4NPT-1"HOSE BARB, POLY
5	10	473001	5/16UNC HEX NUT,NYLOC 316 SS
6	1	611127	1 1/16MJIC-1 1/16MOR ADPTR
7	2	691119	PRESS WASHER SUPP PLT, STS 09
8	1	616459	08-451TC-08FJX-08FJX-26 H/A
9	1	618440	9/16MJIC-90-9/16MOR EX LG LBO
10	1	618474	3/4MJIC-90-1 1/16MOR LBO
11	1	618191	1 1/16MJ-90-1 1/16FJ SWIV LBO
12	1	618787	3/4MJIC-3/8FNPT ADPTR
13	1	690672	HMC 320 SPECIAL/MINUS HOSE
14	1	690931	HOSE REEL,ENCLOSED PRESS WASH
15	1	691114	PRESSURE WASHER MT WLD,STS 09
16	1	715449	3/4FNPT X 3/4MIGHT ADPTR BRS
17	3	900064	5/16UNC X 3/4 HEX BOLT
18	4	473911	5/16UNC-1.31ID-2.00 U-BOLT
19	1	691118	PRESS WASH REEL SUPP WLD,STS09
20	1	520090	HOSE CLAMP NO 16 STAINLESS
21	1	691120	PRESSURE WASHER WAND MT WLD 09
22	4	900129	3/8UNC X 1" SERR FLANGE BOLT
23	4	472029	3/8UNC HEX FLANGE NUT SERR SS
24	1	690941	REEL HOSE,3/8"ID X 50' 3000PSI
25	1	690673	TRIGGER GUN ASSY FOR 690672
26	1	650217	DECAL, CAUTION,CHECK OIL LEVEL
27	1	618184	3/4MJIC-90-3/8MNPT LBO
28	2	691117	PRESSURE WASHER MT ANGL,STS 09
29	4	470325	7/16UNC HEX FLANGE LOCK NUT
30	4	900195	7/16UNC X 1" HEX BOLT
31	1	691092	80/90 BOOM VLV MT WLD,WASHER09
32	1	690799	FEM CPLR FNPT FOR 690672

NOTE: USE TO LIFT LH SOLUTION VALVE

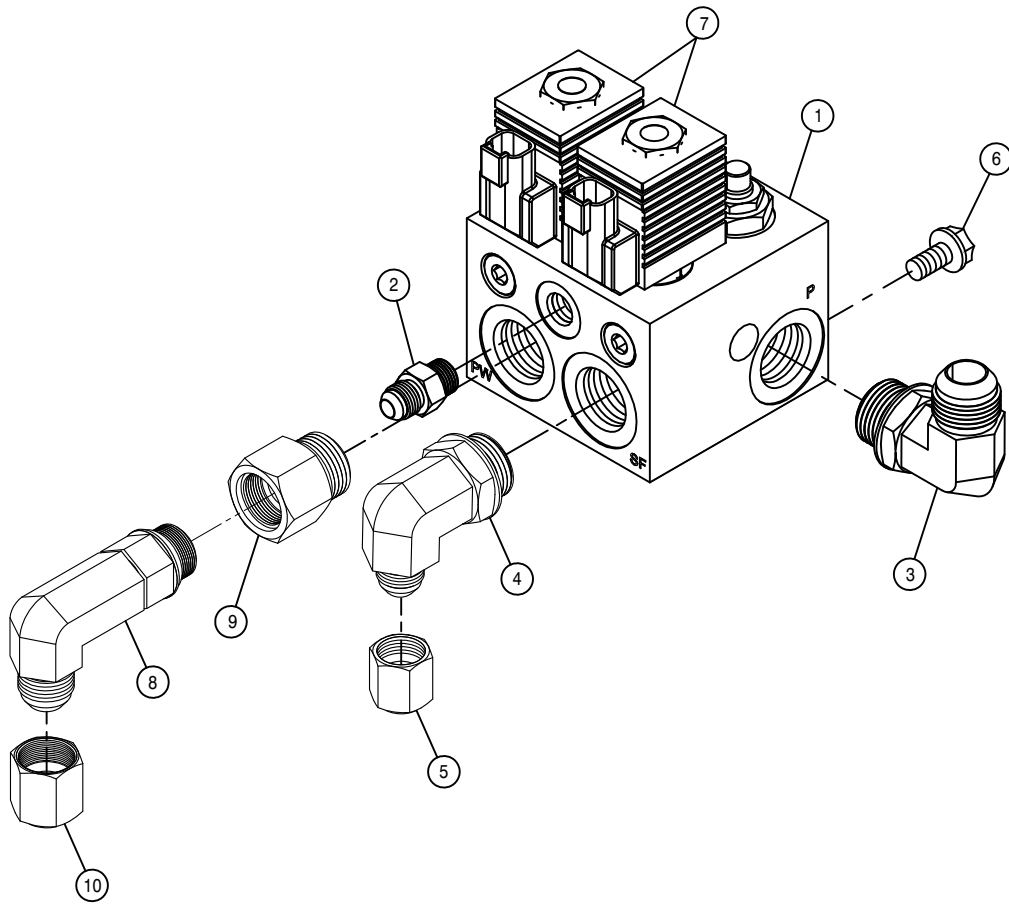

SIDEFILL/PRESSURE WASHER VALVE ASSEMBLY

DET. QTY PART NO. DESCRIPTION

DET.	QTY	PART NO.	DESCRIPTION	
1	1	606259	DIVERSION VLV,STS LS	07
2	1	618126	9/16MJIC-9/16MOR ADPTR	
3	1	618248	1 1/16MJIC-90-1 1/16MOR LBO	
4	1	618474	3/4MJIC-90-1 1/16MOR LBO	
5	1	618532	3/4FJIC CAP NUT	
6	2	900064	5/16UNC X 3/4 HEX BOLT	
7	2	606309	COIL FOR VLV 606259	
8	1	618774	7/8MJIC-90-7/8MOR LG LBO	
9	1	618132	1 1/16MOR-7/8FOR ADPTR	
10	1	618328	7/8FJIC CAP NUT	

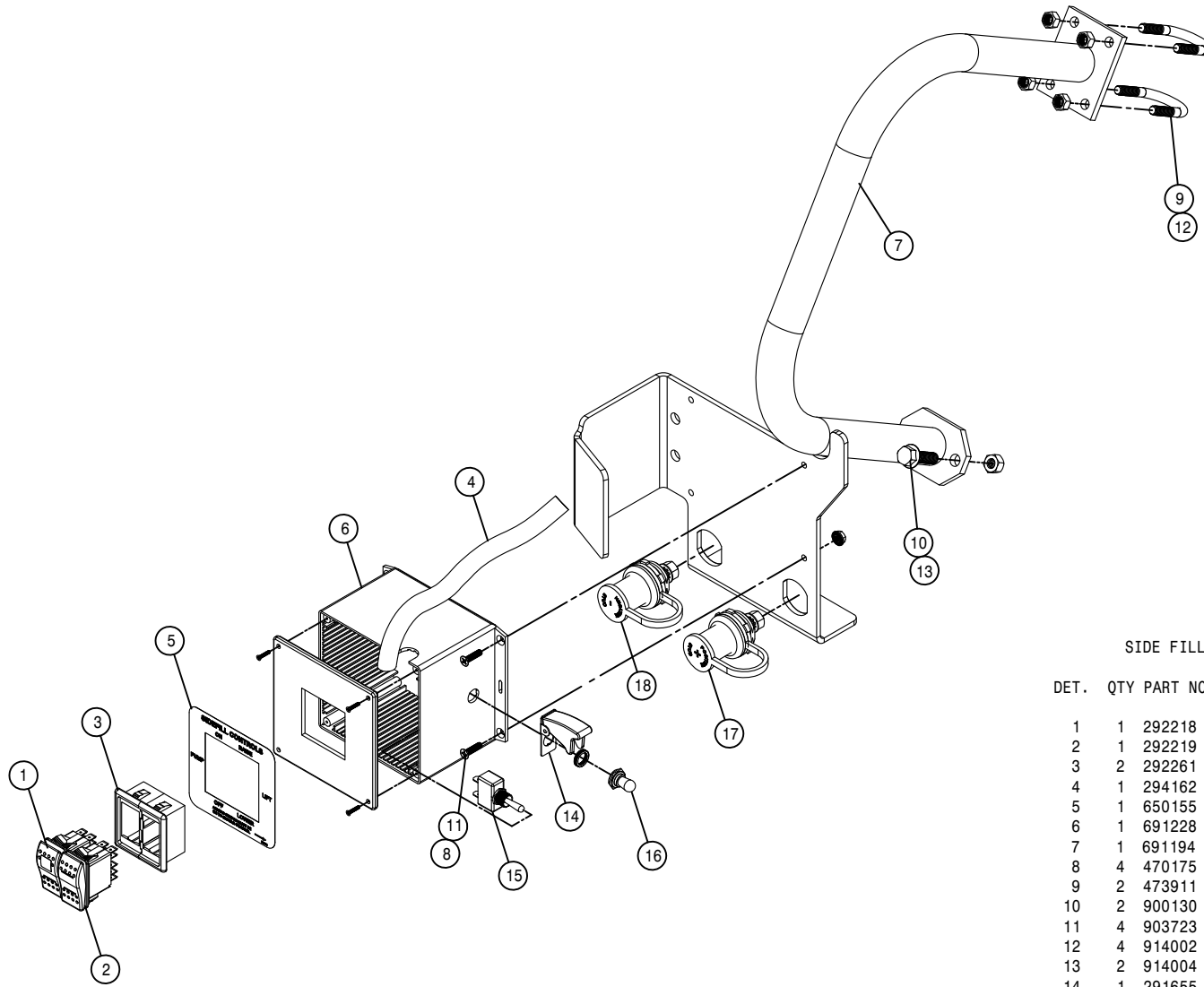

SIDE FILL SWITCH BOX ASSEMBLY

DET. QTY PART NO. DESCRIPTION

DET.	QTY	PART NO.	DESCRIPTION
1	1	292218	SWITCH,SIDE FILL PUMP/PRESWASH
2	1	292219	SWITCH, SIDE FILL LIFT, STS
3	2	292261	MOUNTING TRIM,END VME
4	1	294162	SIDE FILL WIRE HARNESS STS' 12
5	1	650155	DECAL,SIDEFILL CTRL STS 05
6	1	691228	SIDE FILL SWITCH BOX STS' 12
7	1	691194	CHEM IND GUARD WLD '12
8	4	470175	10-32 HEX FLANGE LOCK NUT
9	2	473911	5/16UNC-1.31ID-2.00 U-BOLT
10	2	900130	3/8UNC X 1 1/4 SER FLANGE BOLT
11	4	903723	10-32 x 3/4 PHIL FLHD MACH SCR
12	4	914002	5/16UNC HEX STOVER NUT
13	2	914004	3/8UNC HEX STOVER NUT
14	1	291655	AIRCRAFT TOGGLE SWITCH GUARD
15	1	291937	TOGGLE SWITCH, SPST
16	1	470001	RUBBER BOOT W NUT FOR 298012
17	1	291680	POSITIVE JUMPER STUD, RED
18	1	291681	NEGATIVE JUMPER STUD, BLACK

DET.	QTY	PART NO.	DESCRIPTION
1	1	121101	TRANSOM PIVOT BRG, TOP POLYCOND
2	1	193016	QUICKEDGE TRIM .060 TO .170
3	7	470087	3/8UNC HEX FLANGE LOCK NUT
4	1	470352	LANYARD, 11" POLY
5	1	470643	RUBBER DRAW LATCH
6	4	471005	GREASE ZERK, 1/4-28 X 1/2
7	2	500019	3/4NPT-1/2HOSE BARB, POLY
8	1	500141	2"MNPT-90-2" HOSE BARB, POLY
9	1	500083	2"NPT-90 EL, POLY
10	2	500120	1/2" HOSE BARB TEE, POLY
11	2	500157	1" FLANGE GASKET EPDM
12	2	500159	1" FLANGE CLAMP, S.S.
13	1	500168	1" FLANGE-1" FNPT ADPTR POLY
14	1	500173	1" FLANGE-90-1" HOSE BARB POLY
15	7	500194	2"FP FLANGE CLAMP, S.S.
16	7	500195	2"FP FLANGE GASKET EPDM
17	1	500196	2"FP FLANGE-2" HOSE BARB POLY
18	9	500208	3" FLANGE CLAMP, S.S.
19	9	500209	3" FLANGE GASKET EPDM
20	2	500210	3" FLANGE-3" HOSE BARB POLY
21	2	500212	3"FLANGE-2"FP FLANGE REDU POLY
22	1	500217	3" FLANGE TEE POLY
23	1	500219	2"FP FLANGE-90-2"FP FLANGE LBO
24	2	500263	3"FLANGE-3"MNPT W/3/4"FNPTPOLY
25	1	500249	2"FP FLANGE COUPLING
26	1	500254	2"FP FLANGE-90-2"FP SWEEP LBO
27	1	500258	3" FLANGE-45-3" HOSE BARB POLY
28	1	500259	3"FP-45-3"FP FLANGE LBO POLY
29	1	500260	3"FP-45-Y FLANGE COUPLER POLY
30	1	500261	2"FP FLANGE VENTURI POLY
31	1	601765	HOSE, 1/2 X 13 1BR BLK EPDM
32	2	520068	HOSE CLAMP NO 32 STAINLESS
33	13	520070	HOSE CLAMP NO 8 STAINLESS
34	3	520145	3.56/3.88 T-BOLT HOSE CLAMP SS
35	2	601160	HOSE, 1/2 X 3 1/2 1BR BLK EPDM
36	1	601259	HOSE, 1/2 X 30 1BR EPDM
37	1	713340	1/2NPT-1/2 HOSE BARB, POLY
38	1	601503	HOSE, 3 X 8 POLY HELIX EPDM
39	1	601573	HOSE, 2 X 48 2F-1W EPDM
40	2	601791	HOSE, 1/2 X 12 1BR BLK EPDM
41	1	618119	9/16MJIC-90-9/16MOR LBO
42	1	618183	3/4MJIC-90-7/8MOR LBO
43	1	618535	7/8MJIC-90-1 1/16MOR LBO
44	4	629541	SNAP RING, 1/2"EXTERNAL E-STYLE
45	1	696194	1/2" HOSE BARB MICRO VALVE
46	1	691191	SIDE FILL ARM WLD STS'12
47	1	691192	HOPPER BAND WLD, SIDE FILL '12
48	2	691193	HOPPER PARAL ARM WLD, SIDE FILL
49	1	691197	BUSHING, .750D X 1.31LG
50	1	5000084	2"FNPT-2"MNPT SWIV, POLY
51	1	691225	HOSE SUPP BRKT SIDE FILL '12
52	1	691231	ADJ SIDE FILL CRADLE STS'12
53	1	691236	3" TRANSFER PUMP, HYPRO
54	1	691273	7 GAL RD TANK WITH HOLE
55	1	696147	BALL VLV, 1" FLANGE
56	1	696150	BALL VLV, 2"FP FLANGE STUBBY
57	1	696190	3"FP FLANGE STUBBY VALVE POLY
58	1	696192	3"FLG STUBBY VALVE, 3"MNPT
59	1	696231	CAP FOR 3.00 MALE COUPLER POLY
60	2	900080	5/16UNC X 5" HEX BOLT
61	4	900129	3/8UNC X 1" SERR FLANGE BOLT
62	2	900130	3/8UNC X 1 1/4 SER FLANGE BOLT
63	1	900133	3/8UNC X 2" SERR FLANGE BOLT
64	2	900148	3/8UNC X 8 HEX BOLT
65	2	903706	10-32X1/2 PHIL PAN MACH SCR
66	2	903710	10-32X5/8 PHIL PANHD MACH SCR
67	2	910004N	3/8UNC FLANGE CNTR LOCK NUT
68	2	914002	5/16UNC HEX STOVER NUT
69	4	914027	10-32 HEX STOVER NUT
70	4	920002	3/8 SAE FLAT WASHER
71	2	473963	ROLL PIN, 3/8 X 3 1/2
72	1	520090	HOSE CLAMP NO 16 STAINLESS
73	1	618119	9/16MJIC-90-9/16MOR LBO
74	1	618425	9/16MJIC-45-9/16MOR LBO
75	1	618731	9/16JIC .025 ORIFICE ADPTR
76	1	621554	HYD CYL, 1.50 X 12.25 X .750
77	1	621555	REPAIR KIT, HYD CYL 621554
78	2	690729	WASH: 11GA X 2.69 X 3.50
79	1	691195	CYL MT WLD, SIDE FILL '12
80	4	900265	1/2UNC X 1 1/2 HEX BOLT
81	2	900267	1/2UNC X 2" HEX BOLT
82	6	914008	1/2UNC HEX STOVER NUT
83	1	500044	1/2NPT-90 ST EL, POLY
84	1	500078	1/2NPT-90 EL, POLY
85	1	507031	SS PIPE NIPPLE .50NPT-1.13
86	1	696195	1/2FNPT-1/2MNPT MICRO BALL VLV

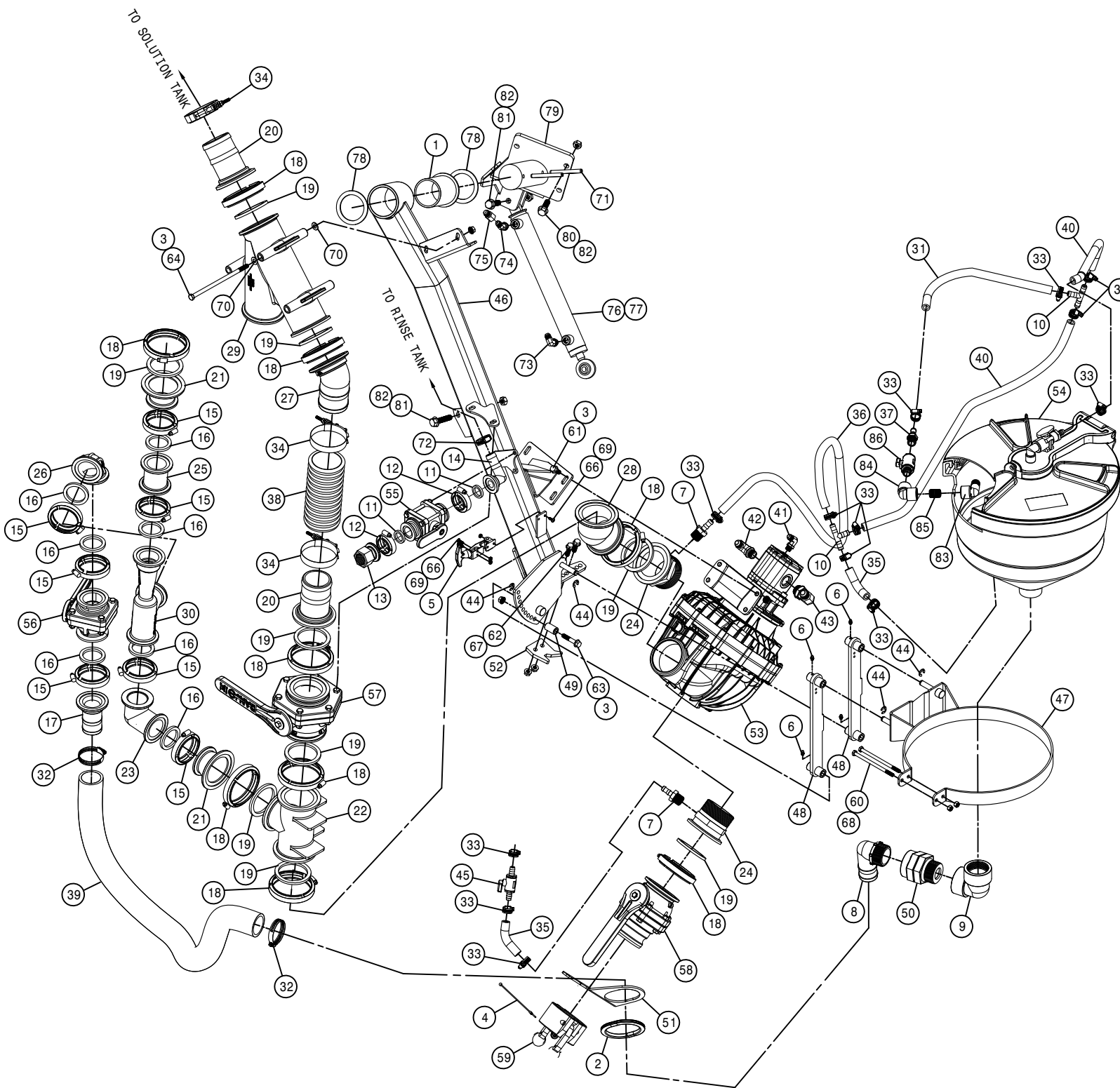

FRONT FILL ASSEMBLY

DET. QTY PART NO. DESCRIPTION

1	1	470352	LANYARD, 11" POLY
2	1	500013	1"NPT HEX PIPE NIPPLE, POLY
3	1	500014	1"NPT-90 ST EL, POLY
4	1	500019	3/4NPT-1/2HOSE BARB, POLY
5	1	500063	1"NPT PIPE PLUG, POLY
6	2	500157	1" FLANGE GASKET EPDM
7	2	500159	1" FLANGE CLAMP, S.S.
8	1	500164	3" FLANGE-3" MNPT ADPTR POLY
9	1	500168	1" FLANGE-1" FNPT ADPTR POLY
10	1	500171	1" FLANGE-1" HOSE BARB POLY
11	4	500208	3" FLANGE CLAMP, S.S.
12	4	500209	3" FLANGE GASKET EPDM
13	1	500210	3" FLANGE-3" HOSE BARB POLY
14	1	500216	3"FLANGE PLUG W/1"FNPT POLY
15	1	500217	3" FLANGE TEE POLY
16	1	505214	1"-3/4"NPT REDU BUSH, POLY
17	1	690488	1.00 CHECK VLV, SPRING LOADED
18	1	691154	FRT FILL SUPP ARM WLD STS' 12
19	1	696147	BALL VLV, 1" FLANGE
20	1	696149	BALL VLV, 3" FLANGE
21	1	696225	3.00FNPT-MALE COUPLER POLY
22	1	696231	CAP FOR 3.00 MALE COUPLER POLY
23	1	470253	HYD DAMPER, 100LB, 4"STROKE 1084
24	2	470254	BALL SOCKET, M6 THD X 10MM
25	2	470255	BALL STUD, 5/16-18 THD X 10MM
26	2	470256	SAFTY CLIP, 10MM BALL SOCKET
27	1	472316	ROLL PIN, 5/16 X 1 1/2
28	1	482017	SPRING
29	1	520090	HOSE CLAMP NO 16 STAINLESS
30	1	520070	HOSE CLAMP NO 8 STAINLESS
31	1	520145	3.56/3.88 T-BOLT HOSE CLAMP SS
32	1	601497	HOSE, 1 X 206 1BR BLK EPDM
33	1	690698	FRT FILL SUPP ARM REL WLD
34	1	691139	FRT FILL SUPP ARM LATCH PIN' 10
35	1	785007	KNOB, 1 3/16" BALL, RED, 3/8-16
36	3	900066	5/16UNC X 1 1/4 HEX BOLT
37	1	900418	3/4UNC X 7" HEX BOLT
38	2	910002	5/16UNC HEX NUT
39	1	914002	5/16UNC HEX STOVER NUT
40	2	473006	3/4UNC HEX JAM NUT, NYLOC
41	1	920006	3/4 SAE FLAT WASHER
42	2	920501	5/16 LOCK WASHER
43	1	601680	HOSE, 3 X 91 POLY HELIX EPDM
44	1	601676	HOSE, 1/2 X 270 1BR BLK EPDM
45	1	691140	FRT FILL LATCH BRKT WLD, STS' 10
46	2	470113	5/16UNC HEX FLANGE LOCK NUT
47	1	291680	POSITIVE JUMPER STUD, RED
48	1	291681	NEGATIVE JUMPER STUD, BLACK

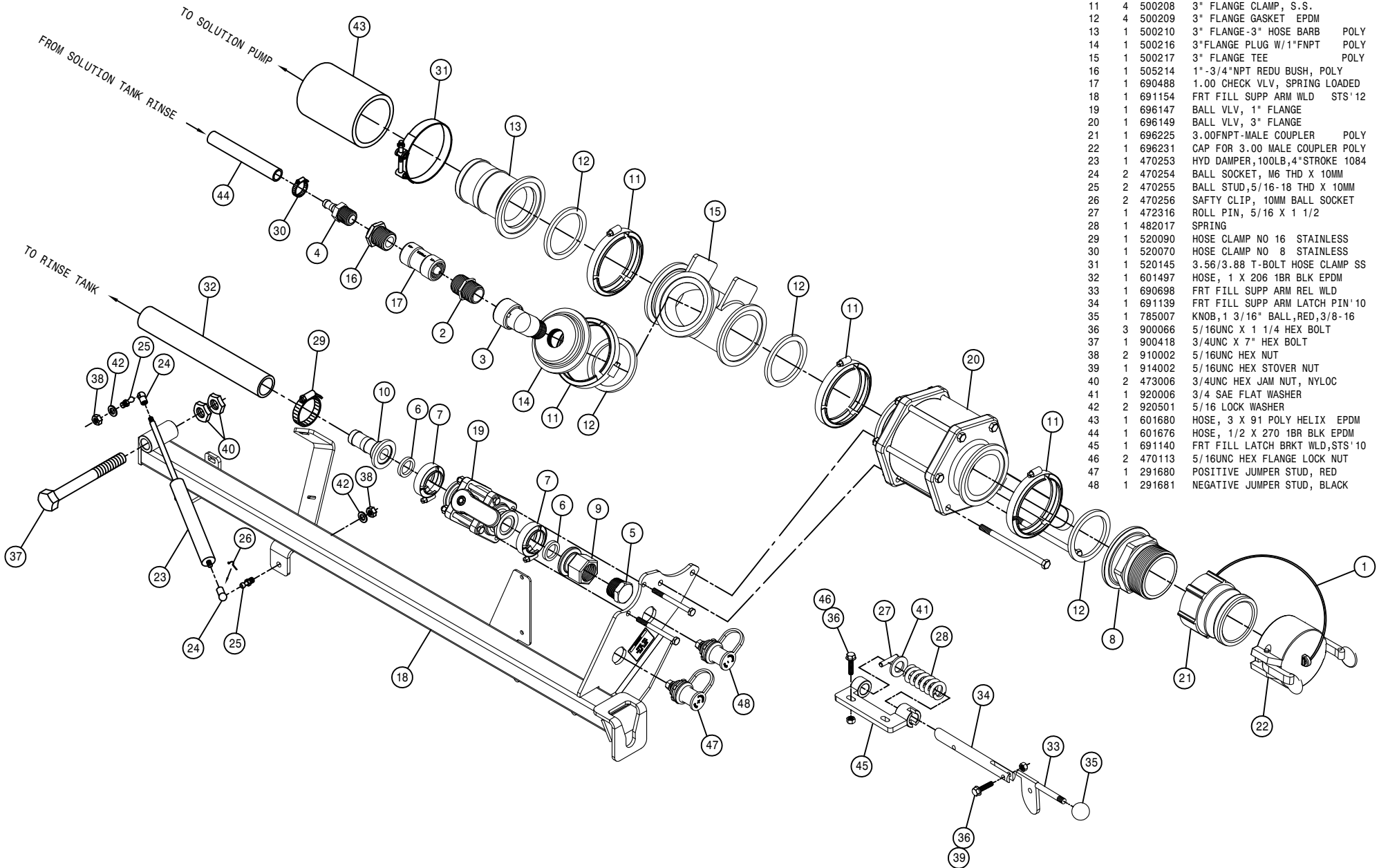

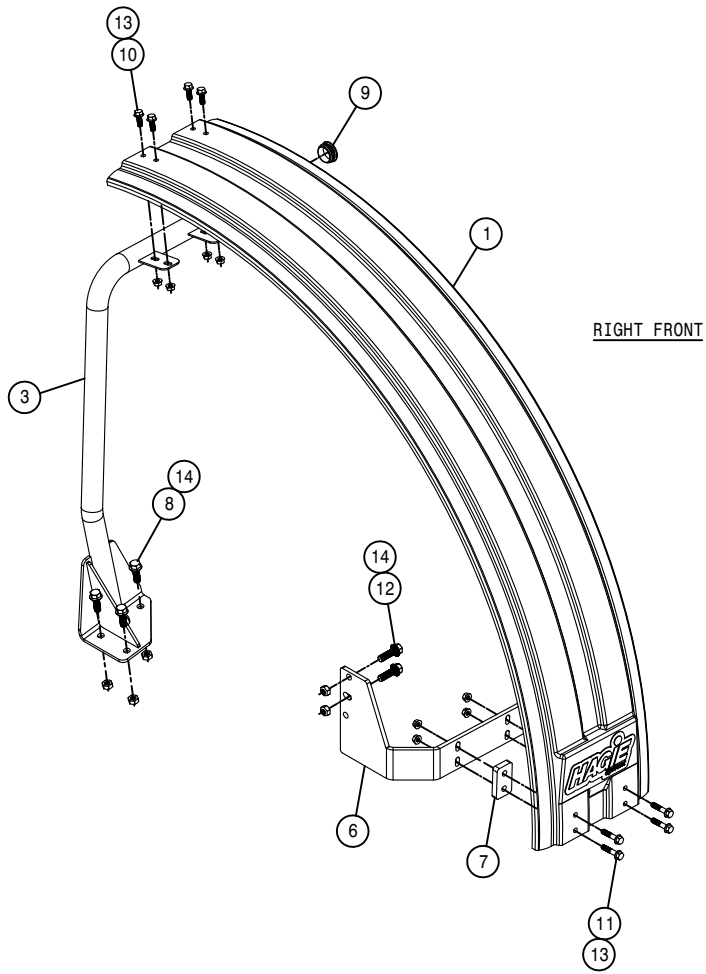

RIGHT FRONT

RIGHT FENDER ASSEMBLY

DET.	QTY	PART NO.	DESCRIPTION	
1	1	359598	FRONT FENDER, STS	'10
2	1	359599	REAR FENDER, STS	'10
3	1	359600	RH FRT FENDER BRKT WLD, STS	'10
4	1	359607	RH REAR FENDER BRKT WLD, STS	'10
5	1	359614	RH REAR UPR FENDER SUPP WLD	'10
6	2	359620	RH LWR FENDER SUPP, STS 54"	'10
7	4	359622	LWR FENDER SUPP SPACER, 54"	'10
8	6	470431	1/2UNC X 1 1/2 FLANGE BOLT	
9	3	629772	CAPPLUGS PLUG, 1 3/4"RD, BLK POLY	
10	12	900129	3/8UNC X 1" SERR FLANGE BOLT	
11	8	900132	3/8UNC X 1 3/4 SER FLANGE BOLT	
12	6	900266	1/2UNC X 1 3/4 HEX BOLT	
13	20	910004N	3/8UNC FLANGE CNTR LOCK NUT	
14	12	914008	1/2UNC HEX STOVER NUT	

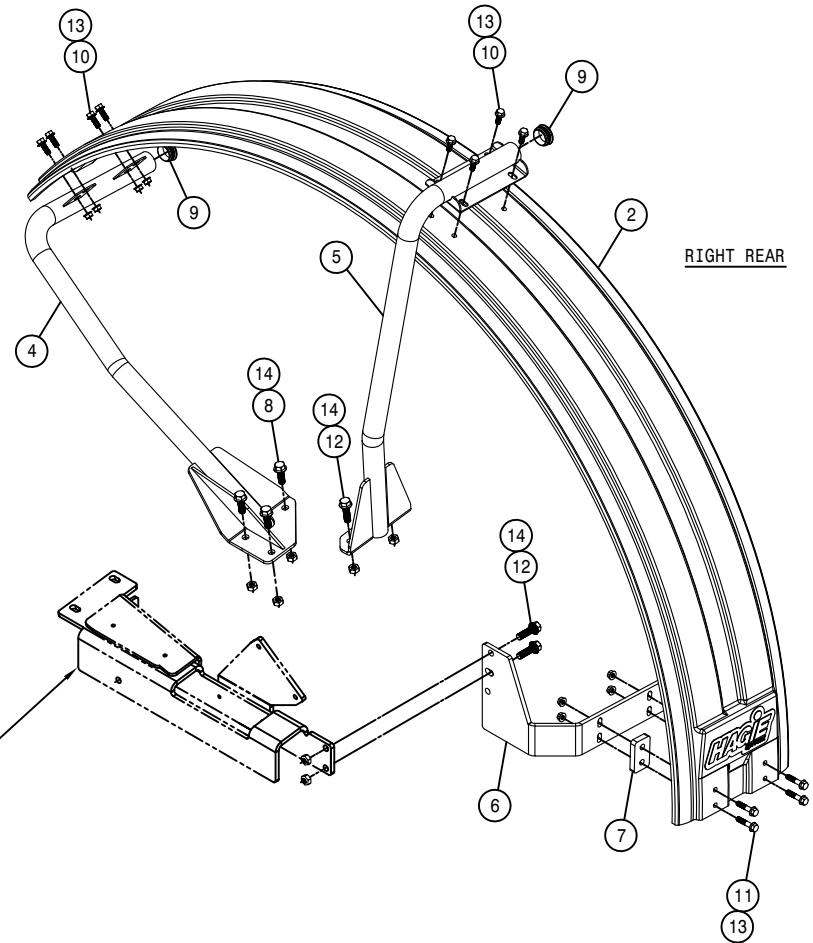

RIGHT REAR

NOTE: 359624 SHOWN FOR REFERENCE
SEE LEG ASSEMBLY

LEFT FENDER ASSEMBLY

DET. QTY PART NO. DESCRIPTION

1	1	359598	FRONT FENDER, STS	'10
2	1	359599	REAR FENDER, STS	'10
3	1	359601	LH FRT FENDER BRKT WLD, STS	'10
4	1	359608	LH REAR FENDER BRKT WLD, STS	'10
5	1	359615	LH REAR UPR FENDER SUPP WLD	'10
6	1	359621	LH LWR FENDER SUPP, STS 54"	'10
7	4	359622	LWR FENDER SUPP SPACER, 54"	'10
8	6	470431	1/2UNC X 1 1/2 FLANGE BOLT	
9	3	629772	CAPPLUGS PLUG, 1 3/4"RD, BLK POLY	
10	12	900129	3/8UNC X 1" SERR FLANGE BOLT	
11	8	900132	3/8UNC X 1 3/4 SER FLANGE BOLT	
12	6	900266	1/2UNC X 1 3/4 HEX BOLT	
13	20	910004N	3/8UNC FLANGE CNTR LOCK NUT	
14	12	914008	1/2UNC HEX STOVER NUT	

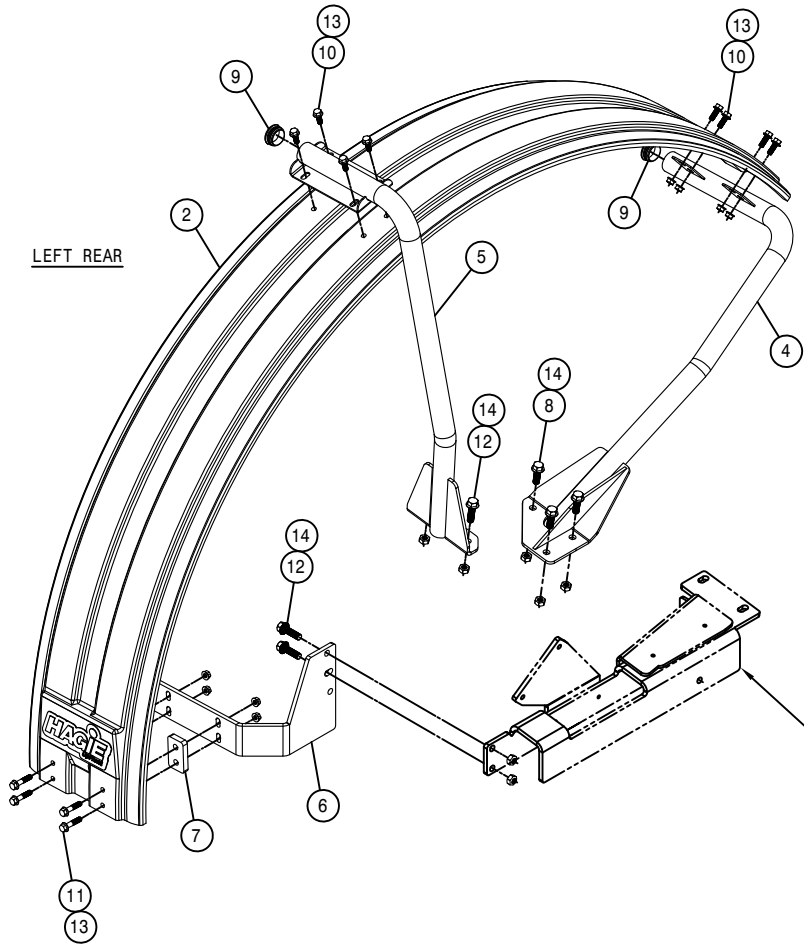

LEFT REAR

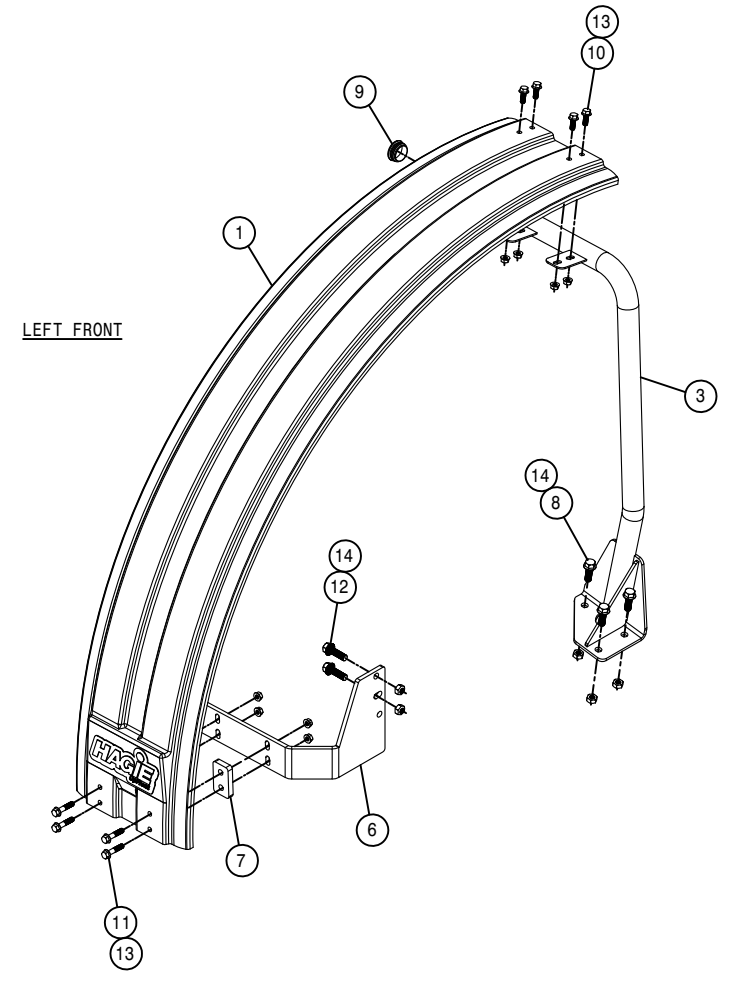

LEFT FRONT

NOTE: 359625 SHOWN FOR REFERENCE
SEE LEG ASSEMBLY

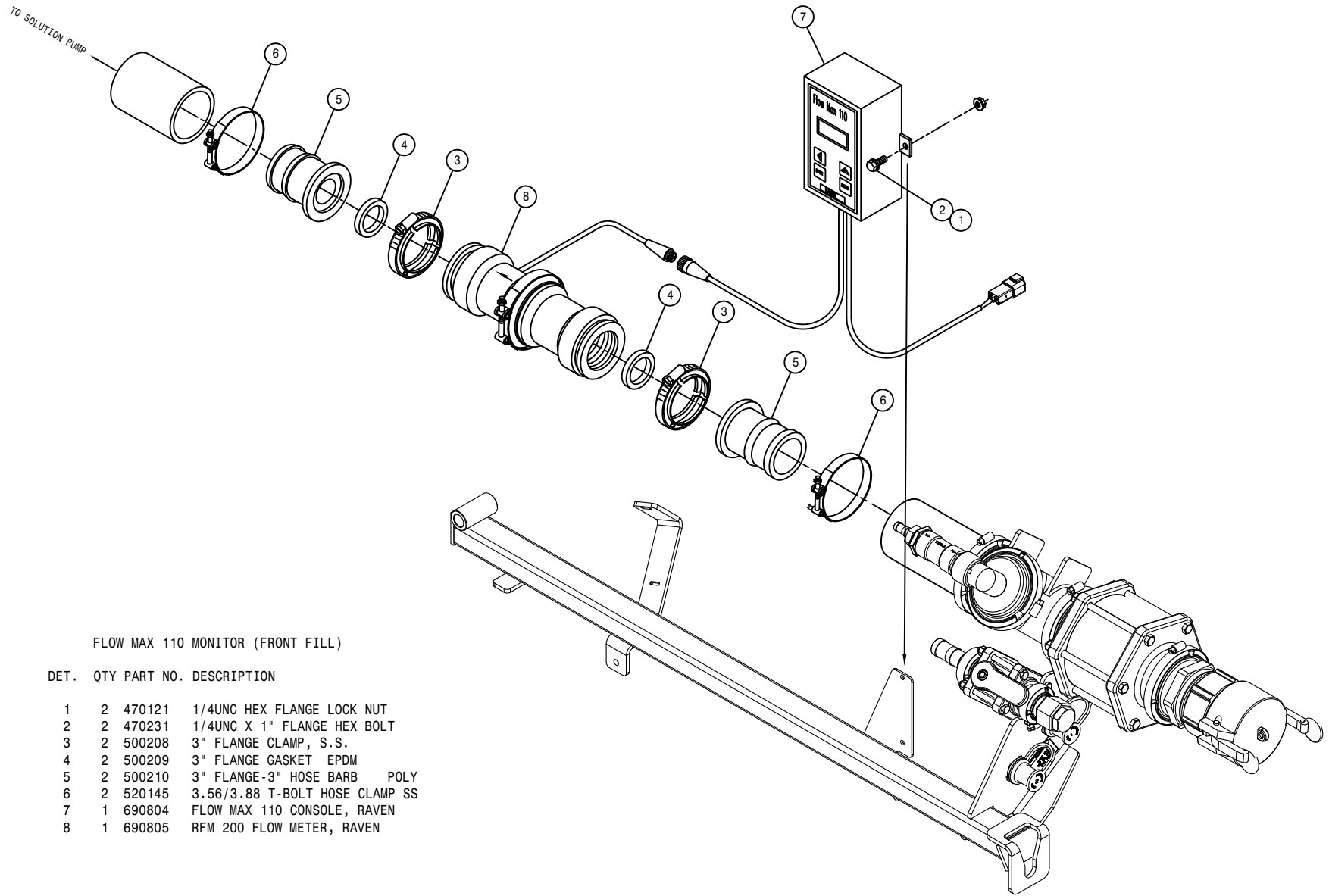

FLOW MAX 110 MONITOR (FRONT FILL)

DET.	QTY	PART NO.	DESCRIPTION
	2	470121	1/4UNC HEX FLANGE LOCK NUT
	2	470231	1/4UNC X 1" FLANGE HEX BOLT
	2	500208	3" FLANGE CLAMP, S.S.
	2	500209	3" FLANGE GASKET EPDM
	2	500210	3" FLANGE-3" HOSE BARB POLY
	2	520145	3.56/3.88 T-BOLT HOSE CLAMP SS
	1	690804	FLOW MAX 110 CONSOLE, RAVEN
	1	690805	RFM 200 FLOW METER, RAVEN

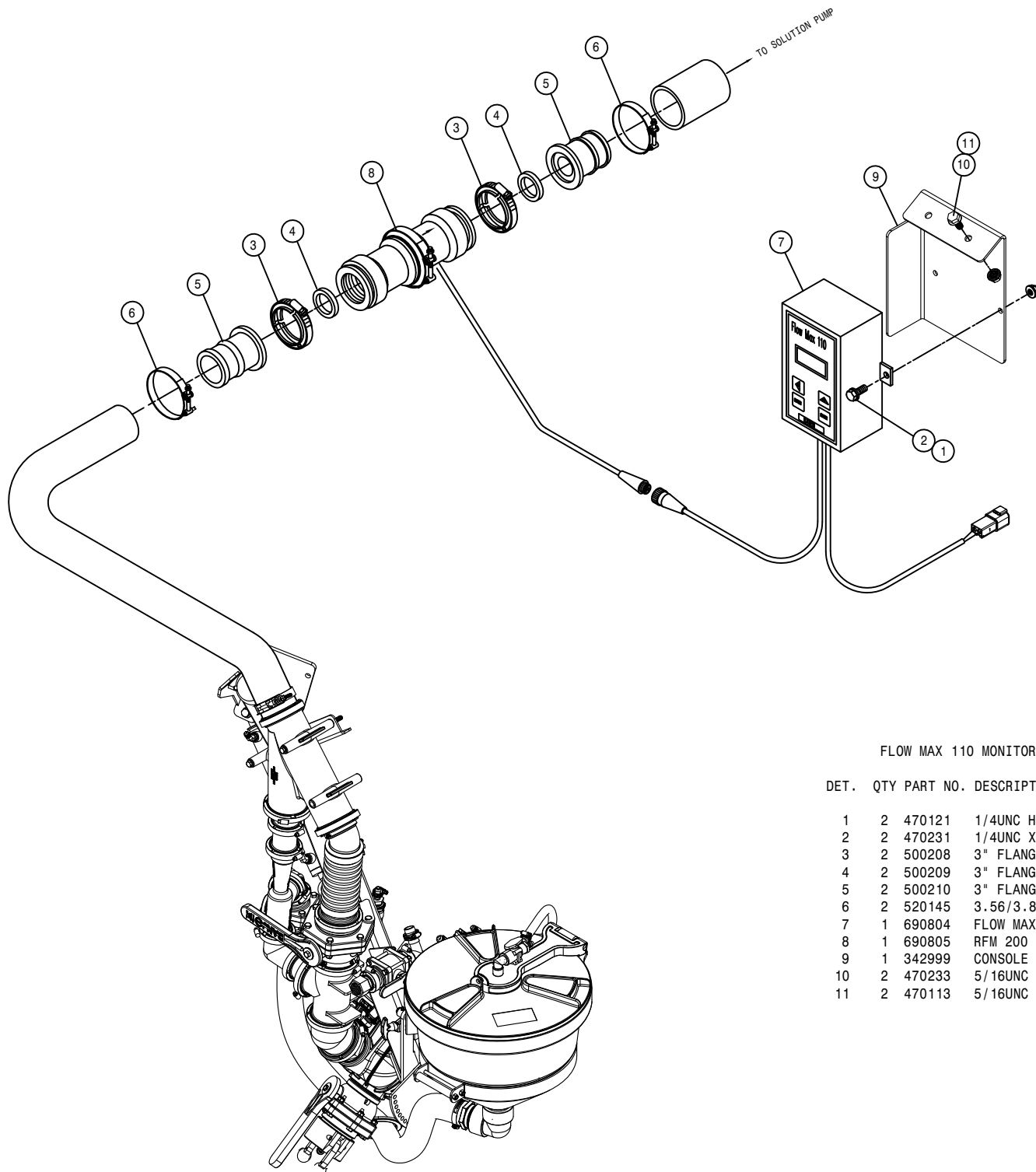

FLOW MAX 110 MONITOR (SIDE FILL)

DET. QTY PART NO. DESCRIPTION

1	2	470121	1/4UNC HEX FLANGE LOCK NUT
2	2	470231	1/4UNC X 1" FLANGE HEX BOLT
3	2	500208	3" FLANGE CLAMP, S.S.
4	2	500209	3" FLANGE GASKET EPDM
5	2	500210	3" FLANGE-3" HOSE BARB POLY
6	2	520145	3.56/3.88 T-BOLT HOSE CLAMP SS
7	1	690804	FLOW MAX 110 CONSOLE, RAVEN
8	1	690805	RFM 200 FLOW METER, RAVEN
9	1	342999	CONSOLE MT,SIDE,FLOMAX 110 '12
10	2	470233	5/16UNC X 3/4 FLANGE HEX BOLT
11	2	470113	5/16UNC HEX FLANGE LOCK NUT

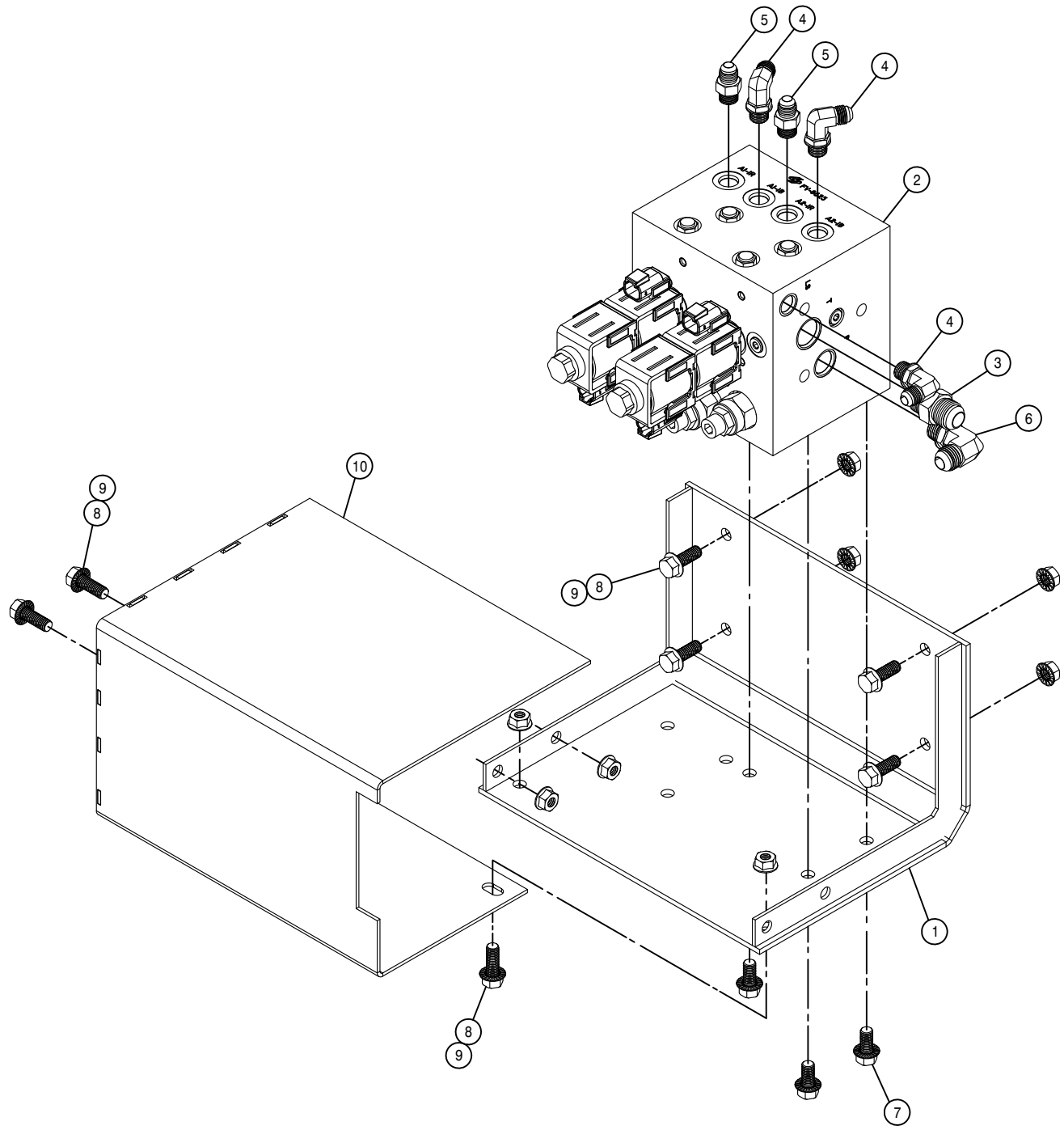

AWS HYDRAULIC VALVE ASSEMBLY

DET.	QTY	PART NO.	DESCRIPTION	
1	1	361872	AWS VALVE MT WLDMT, STS	09
2	1	606370	VALVE, FV8623 V1 SUNSOURCE	
3	1	611126	7/8MJIC-7/8MOR ADPTR	
4	3	618119	9/16MJIC-90-9/16MOR LBO	
5	2	618126	9/16MJIC-9/16MOR ADPTR	
6	1	618241	3/4MJIC-90-3/4MOR LBO	
7	3	900128	3/8UNC X 3/4 HEX BOLT	
8	8	900129	3/8UNC X 1" SERR FLANGE BOLT	
9	8	470087	3/8UNC HEX FLANGE LOCK NUT	
10	1	361908	AWS MANIF COVER WLD	

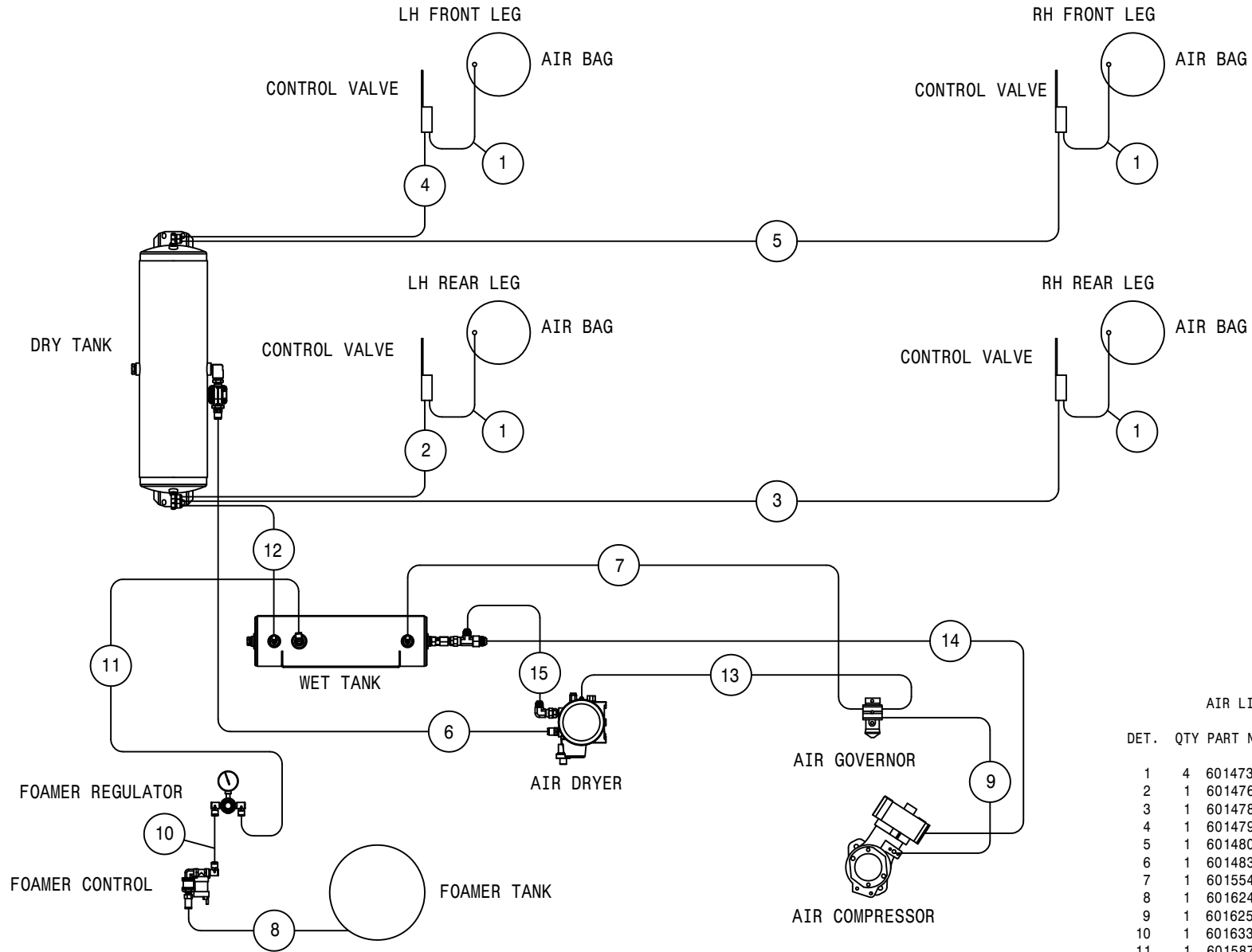

AIR LINE DIAGRAM STS 10/12

DET.	QTY	PART NO.	DESCRIPTION
1	4	601473	HOSE, 1/4 X 18 AIR
2	1	601476	HOSE, 1/4 X 120 AIR
3	1	601478	HOSE, 1/4 X 175 AIR
4	1	601479	HOSE, 1/4 X 196 AIR
5	1	601480	HOSE, 1/4 X 230 AIR
6	1	601483	HOSE, 1/2 X 84 AIR
7	1	601554	HOSE, 1/4 X 46 AIR
8	1	601624	HOSE, 3/8 X 60 AIR
9	1	601625	HOSE, 1/4 X 14 AIR
10	1	601633	HOSE, 3/8 X 11 AIR
11	1	601587	HOSE, 3/8 X 102 AIR
12	1	601592	HOSE, 1/4 X 69 AIR
13	1	601707	HOSE, 1/4 X 63 AIR
14	1	611306	12-P919J-12FJX-12FJX90-42 H/A
15	1	611307	10-P919J-10FJX-10FJX-40 H/A

NOTICE

The following page contains decals for the model STS 12.

These decals can be obtained from Hagie Mfg. Co. and should be used whenever your machine is repainted or when the decals become worn, weathered, or faded.

Special attention should be paid to decals involving personal safety. They have been attached for your protection.

KEEP THEM IN PLACE.

**Contact: Hagie Manufacturing Co.
721 Central Ave West
Box 273
Clarion, Iowa 50525**

STS12 DECALS

QTY.	PART NO.	DESCRIPTION	LOCATION
4	650103	TREAD ADJUST INDICATOR DECAL	1-ON EACH LEG SLIDE TUBE
1	650107	CAUTION BOOSTER DECAL	NEAR BOOSTER POSTS
1	650114	FILL WITH FRESH WATER DECAL	ON FRESH WATER TANK
1	650115	HAND WASH ONLY DECAL	NEAR HAND WASH VALVE
1	650116	INDUCTOR FILL INSTRUCTION DECAL	ON SIDE OF FILL ARM
1	650118	DO NOT USE EITHER DECAL	NEAR AIR INTAKE ON SHEET METAL
1	650125	AGITATOR RATE IND DECAL	ON KZCO AGITATION VALVE
1	650132	CUMMINS POWER DECAL	LOCATED ON ENGINE HOOD
1	650140	ENGINE COMPARTMENT DECAL SET	ON ENGINE HOOD
2	650144	LOGO, SOLUTION TANK DECAL	ON EACH SIDE SOLUTION TANK
1	650154	PATENTS,HAGIE UPFRONT DECAL	ON LOWER LEFT REAR OF MAINFRAME
1	650155	SIDE FILL CONTROL DECAL	ON SIDE FILL SWITCH BOX
1	650156	PRESS WASH CONTROL DECAL	ON PRESS WASHER SWITCH BOX
1	650158	SPEED CONTROL STS CAB DECAL	ON CONSOLE
1	650159	THROTTLE BRAKE PUMP DECAL	ON CONSOLE
1	650163	POWER POINT DECAL	ON CONSOLE
1	650164	NO PASSNGR/NOT NEAR LEAK DECAL	ON LEFT UPPER REAR POST
1	650165	PMR LINE/BM FOLD/GLASS DECAL	ON RIGHT REAR UPPER CAB POST
1	650174	RADIATOR CAUTION DECAL	ON TOP OF RADIATOR
1	650176	CAUTION, CAB CHEM EXPOSER DECAL	ON UPPER RIGHT SIDE WINDOW
2	650178	CAUTION QUICK ATTACK PIN DECAL	1-EA ON FRONT CROSSMEMBER BY Q-ATTACH
1	650217	CAUTION, CHECK OIL DECAL	ON PRESSURE WASHER MOUNT
1	650223	30MPH ID SYMBOL DECAL	ON REAR BUMPER
1	650231	AUX POWER DECAL	ON THE BOTTOM OF CONSOLE
1	650232	AUX POWER LOCATION DECAL	ON CONSOLE
1	650234	ENGINE ELECTRICAL BOX DECAL	INSIDE ENGINE ELECTRICAL BOX
1	650256	EXPLOSION/RELEASE POWER DECAL	NEAR RADIATOR CAP
1	650272	200 AMP ECM SUSE DECAL	NEAR AIR CLEANER MOUNT
1	650275	CONTROL CENTER DECAL	ON CONSOLE
1	650278	E-STOP DECAL	ON CONSOLE
2	650339	WARNING, HYD OIL IND DECAL	1-ON SIDE OF OIL TANK
1	650348	NOTICE DRAIN AIR TANK DECAL	ON AIR TANK
1	650367	AIR FILTER INSTRUCTION DECAL	ON ENGINE AIR FILTER END CAP
1	650372	MAIN ELECTRICAL DISCONNECT DECAL	NEAR BOOSTER POSTS
1	650377	NOTICE-R134A 3LB DECAL	1-NEAR ELECTIC VALVE ON TRANSONM RH SIDE OF ENGINE ON FRAME
1	650396	CONSOLE FUSE-RELAY DECAL	ON CONSOLE
1	650397	BOOM SPRAY SECTIONS DECAL	ON CONSOLE
1	650398	CAB CONSOLE MODULES DECAL	IN CONSOLE
1	650399	FLASHER/LIGHT MODULE DECAL	ON BELLY PAN
1	650400	BELLY PAN MODULE DECAL	ON BELLY PAN
2	650401	AUX POWER PORT DECAL	1-UNDER SIDE FILL SWITCH BOX 1-ON FRONT FILL ARM
1	650402	REAR CHASSIS MODULE DECAL	INSIDE REAR ELECTRICAL BOX
1	650406	SIGHT GAUGE DECAL	ON THE LEFT REAR OF CAB
1	650410	FUSE/RELAY MODULE, STS DECAL	ON BELLY PAN
1	650848	CAUTION, SLIP OR FALL DECAL	ON LADDER PIVOT TUBE
1	650849	CAUTION, ENGINE FUEL DECAL	NEAR FUEL TANK NECK
1	650850	DANGEROUS CHEM DECAL	SOLUTION TANK FILLER NECK
1	650851	SHIELDS DECAL	ON LOWER LH REAR MAINFRAME TUBE
1	650954	DIESEL DECAL	NEAR FUEL TANK NECK
1	650982	ELECTRICAL DECAL	ON RH CAB DOOR
4	650985	WHEEL BOLT TORQUE DECAL	ON EACH WHEEL RIM

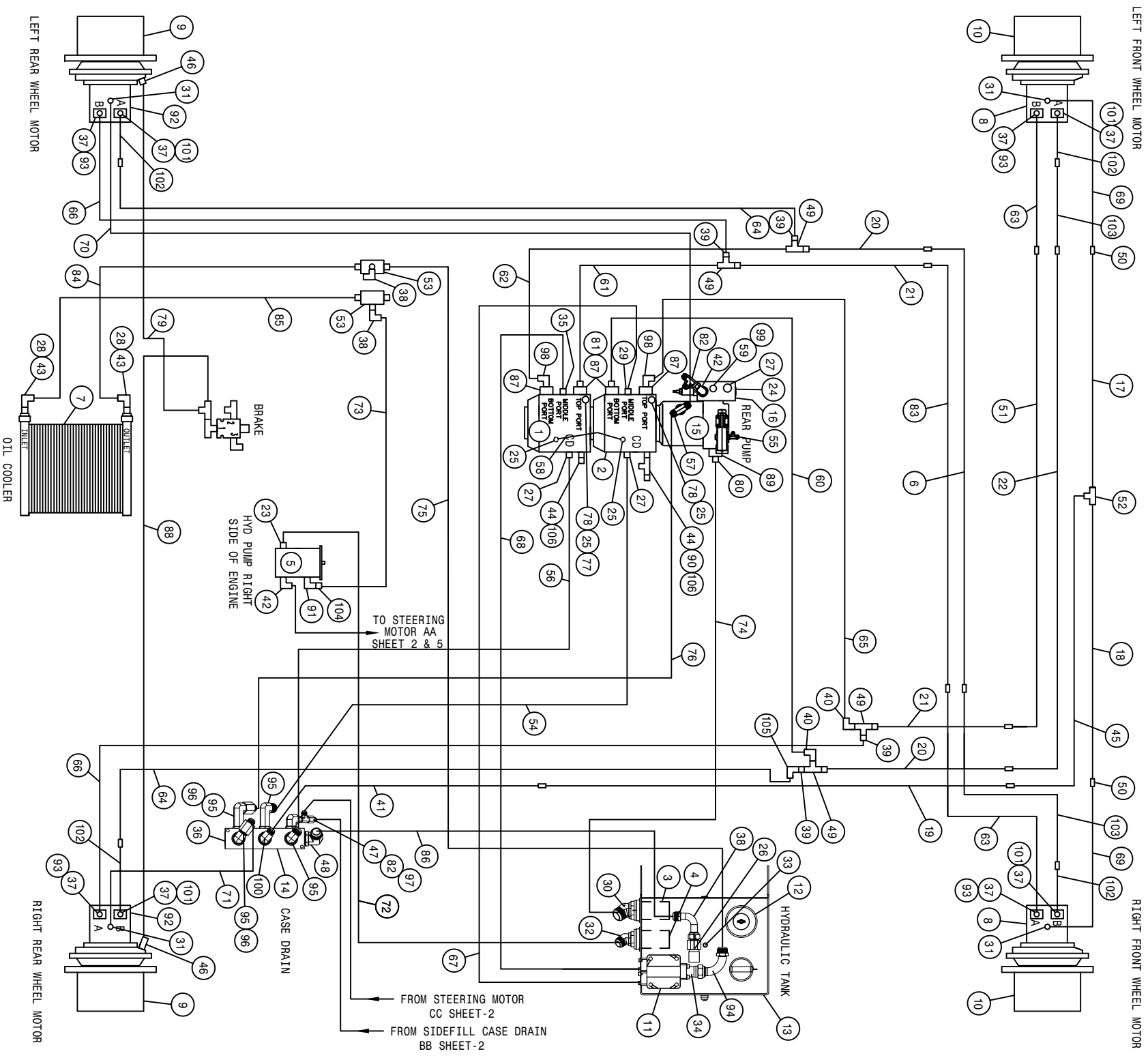

STS 10/12 STANDARD HYDRAULIC DIAGRAM 2012
REFERENCE DRAWING NO. 499244SI

DET.	QTY	PART NO.	DESCRIPTION	DET.	QTY	PART NO.	DESCRIPTION
1	1	606512	H1-P-115CC PUMP,D/D-MT	54	1	616984	16-451TC-16FCX-16FCX90-45 H/A
2	1	606513	H1-P-115CC PUMP,D/B-MT	55	1	618509	7/16MOR RUN TEE-7/16MJIC
3	1	605623	SUCTION STRAINER,39GPM 100M 32	56	1	616983	16-451TC-16FCX-16FCX90L-41 H/A
4	1	605622	SUCTION STRAINER,21GPM 100M 24	57	1	618130	7/8MOR RUN TEE-7/8MJIC
5	1	606450	TANDEM PUMP,606451 & 606452	58	1	616038	04-471TC-06FCX-06FCX90-15 H/A
6	1	615848	RH FRONT HYDROSTAT TUBE ASSY	59	1	611126	7/8MJIC-7/8MOR ADPTR
7	1	618800	OTL COOLER STS12 2000	60	1	616987	20-791TC-20FFOX-20FFOX90-47H/A
8	2	606386	WHL MOTOR,51C060 SAUER W/DEUTS	61	1	616985	20-791TC-20FFOX-20FFOX-54 H/A
9	2	610965	WHEEL HUB,27:1 W/BRAKE BONFIG	62	1	616988	20-791TC-20FFOX-20FFOX90-68H/A
10	2	610962	WHEEL HUB,23:1 BONFIG	63	2	616565	16-792TC-16FFOX-16FFOX-129 H/A
11	1	605625	IN-TANK RETURN FILTER, 10M	64	2	616339	16-792TC-16FFOX-16FFOX-146 H/A
12	1	605647	BREATHER-HYD RSRVR	65	1	616986	20-791TC-20FFOX-20FFOX90-26H/A
13	1	760732	HYD TANK W/LD,STSL0/12/14 '10	66	2	616566	16-792TC-16FFOX-16FFOX90-151H/
14	1	606246	MANIFOLD, #16 3-STN 180	67	1	616989	20-881-20FLG-20FCX90-83 H/A
15	1	607004	SAUER PISTON PUMP JRR608	68	1	616990	20-881-20FLG-20FCX90-96 H/A
16	1	606258	REFIEF, LS PUMP SAUER	69	2	617050	08-451TC-10FCX-08FCX45-142 H/A
17	1	615823	LH FRT CASEDRAIN HYD TUBE ASSY	70	1	616373	08-451TC-10FCX-08FCX45-212 H/A
18	1	615822	RH FRT CASEDRAIN HYD TUBE ASSY	71	1	616265	08-451TC-12FCX-08FCX45-175 H/A
19	1	615854	M/F CASE DRAIN TUBE,STSL0 07	72	1	616346	24-881-24FCX-24FCX90M-103 H/A
20	2	615904	OUTER HYDRO TUBE ASSY,10/12'12	73	1	616347	16-881-20FCX-16FCX90M-59 H/A
21	2	615905	INNER HYDST TUBE ASSY,10/12'12	74	1	616343	32-881-32FCX-32FCX-53 H/A
22	1	615849	LH FRONT HYDROSTAT TUBE ASSY	75	1	616399	24-881-20FCX-24FCX90-105 H/A
23	1	618527	1 7/8MJIC-1 5/8MOR ADPTR	76	1	616982	10-451TC-12FCX-10FCX90-25 H/A
24	1	618753	7/16MOR PLUG, HEX SOCKET	77	1	618735	9/16JIC .062 ORIFICE ADPTR
25	4	606196	PRESS TRANSDUCER ASSY 9000PSI	78	2	618782	9/16MOR-9/16FOR-9/16MJIC BRNGH
26	1	618767	1 7/8FJIC-1 5/8MJIC ADPTR	79	1	616073	04-451TC-06FCX-04FCX45-202 H/A
27	3	618186	1 5/16MJIC-1 5/16MOR ADPTR	80	1	618765	2" FLANGE-2 1/2MJIC ADPTR #61
28	2	618640	1 5/16MJ-90-1 5/16FJ SWIV LBO	81	2	618897	1 1/4"FLANGE-1 11/16MFOR ADPTR
29	2	618472	1 5/8MJIC-1 5/8MOR ADPTR	82	2	618451	3/4FJIC SW RUN TEE-3/4MJIC
30	1	618746	2 1/2MJIC-45-2 1/2MOR LBO	83	1	615885	RH FRT WHL MAIN TUBE ASY,STS09
31	4	618469	3/4MJIC-1 1/16MOR ADPTR	84	1	616398	20-881-16FCX-20FCX-83 H/A
32	1	618745	1 7/8MJIC-45-1 7/8MOR LBO	85	1	616397	20-881-16FCX-20FCX-77 H/A
33	1	470471	1 5/16MOR PLUG, MAGNETIC	86	1	616396	20-881-20FCX-20FCX90-70 H/A
34	1	618747	1 1/2 FLANGE-1 7/8MJIC ADPTR	87	8	618780	1 1/4 SPLIT FLANGE HALF, #62
35	1	618724	1 5/8MJIC-1 5/8MOR LG ADPTR	88	1	616372	04-451TC-06FCX-04FCX45-222 H/A
36	1	618759	1 5/8MOR PLUG, HEX SOCKET	89	1	618766	2" SPLIT FLANGE KIT #61
37	8	618431	3/4 (-12) SPLIT FLANGE KIT #62	90	1	618486	9/16FJIC SW RUN TEE-9/16MJIC
38	3	618768	1 5/8MJIC-90-1 5/8FCX TUBE	91	1	618279	1 1/16MJIC-90-7/8MOR LBO
39	4	618785	1 11/16FOR-1 7/16MFOR ADPTR	92	2	606387	WHL MOTOR,51C060 W/SENSOR-DEUTS
40	2	618895	1 11/16MFOR-90-1 11/16FFOX ADP	93	4	618812	3/4 FLANGE-1 7/16MFOR ADPTR
41	1	616444	10-451TC-12FCX-12FCX90-48 H/A	94	1	618764	1 7/8MJIC-90-1 7/8FCX TUBE LBO
42	2	618183	3/4MJIC-90-7/8MOR LBO	95	4	618463	1 5/16MJIC-90-1 5/16MOR XL LBO
43	2	618830	1 5/16MJ-1 5/16MOR 6. OLG ADPTR	96	2	618541	1 5/16FCJIC-1 1/16MJIC ADPTR
44	2	618126	9/16MJIC-9/16MOR ADPTR	97	1	618482	3/4FJIC-9/16MJIC ADPTR
45	1	616388	10-451TC-12FCX-10FCX90-91 H/A	98	2	618779	1 11/16MFOR-90-1 1/4FLG C62LBO
46	2	618467	7/16MJIC-7/16MOR ADPTR	99	1	618333	7/8FJIC SW RUN TEE-7/8MJIC
47	1	618475	3/4MJIC-90-1 5/16MOR LBO	100	1	618302	1 1/16MJIC-90-1 5/16MOR LBO
48	1	618477	1 5/8MJIC-90-1 5/8MOR LBO	101	4	618740	3/4 FLANGE-90-1 7/16MFOR LBO
49	4	618778	1 11/16FFOX RUNTEE-1 11/16MFOR	102	4	615875	WHEEL MOTOR HYD TUBE ASSY
50	2	618456	7/8MJIC UNION	103	2	616338	16-792TC-16FFOX-16FFOX-127 H/A
51	1	615886	LH FRT WHL MAIN TUBE ASY,STS09	104	1	618641	1 1/16FCJIC-1 5/16MJIC ADPTR
52	1	618581	7/8MJIC UNION TEE	105	1	618362	1 7/16MFOR-90-1 7/16FFOR LBO
53	2	618752	1 5/8MJIC BLKHD RUN TEE	106	2	618531	9/16FCJIC CAP NUT

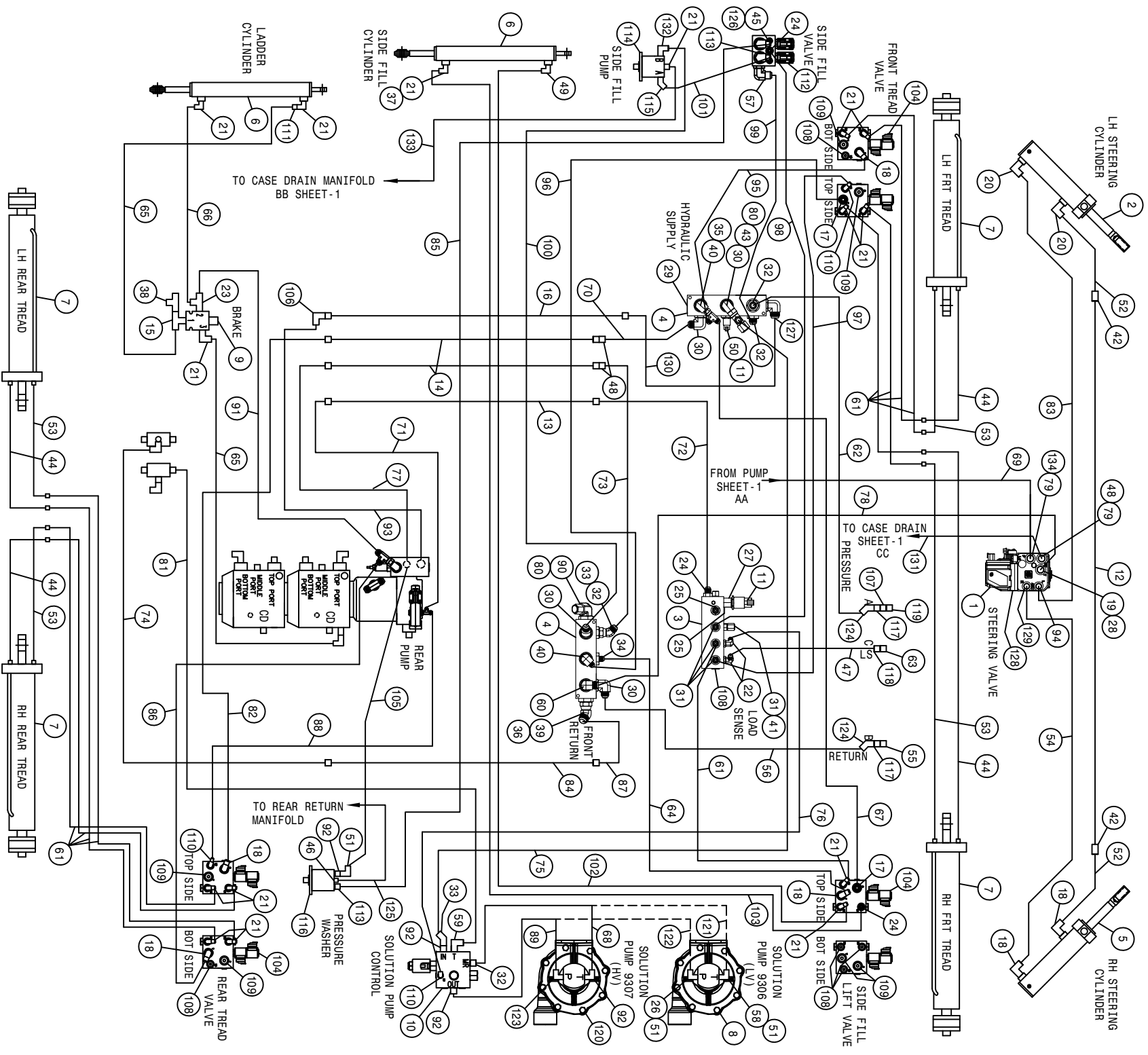

STS 10/12 STANDARD HYDRAULIC DIAGRAM 2012
REFERENCE DRAWING NO. 4992244S2

DET.	QTY	PART NO.	DESCRIPTION	DET.	QTY	PART NO.	DESCRIPTION
1	1	749333	STRG CTRL VLV, OSPEDC 60/260	69	1	617012	06-4511TC-06FX-08FX90-212 H/A
2	1	621550	HYD CYL, 2.50 X 8.81 X 1.250	70	1	616308	10-4511TC-10FX-12FX-12 H/A
3	1	606247	MANIFOLD W/CHK VLV SAUER	71	1	616320	04-4511TC-04FX-04FX90-47 H/A
4	2	606246	MANIFOLD, #16 3-STN 180	72	1	616435	04-4511TC-06FX-04FX45-20 H/A
5	1	621614	HYD CYL, 2.50 X 8.81 PHASE/2SEN	73	1	616310	10-4511TC-10FX-12FX-24 H/A
6	2	621554	HYD CYL, 1.50 X 12.25 X .750	74	1	616334	16-881-16FX-20FX-51 H/A
7	4	621552	HYD CYL, 3.00 X 16.00 X 1.375	75	1	616330	10-4511TC-12FX-12FX90-87 H/A
8	1	691160	HYPRO PUMP,9306C-IM5C-BU,FLG	76	1	616438	04-4511TC-04FX-04FX45-51 H/A
9	1	606213	HYD SOLE VLV,2P-3M,9/16FOR	77	1	616327	10-4511TC-10FX-10FX90-44 H/A
10	1	606253	CTRL VALVE,SOLU PUMP SAUER	78	1	617017	10-4511TC-10FX-12FX90-82 H/A
11	2	606347	PRESSURE TRANSDUCER,7500PSI	79	2	618911	7/8MJIC-M22 MOR ADPTR
12	1	615772	STRG CYL JUMPER HD TUBE ASSY	80	2	618533	1 1/16FJIC CAP NUT
13	1	615850	M/F HYD TUBE, LS LINE,ST510 07	81	1	616406	16-881-20FX-16FX90-122 H/A
14	2	615853	M/F HYD TUBE,PRES,RTN ST510 07	82	1	616326	08-4511TC-08FX-10FX90-48 H/A
15	1	618629	9/16MOR BRANCH TEE-9/16MJIC	83	1	616730	08-4511TC-08FX-08FX90-108 H/A
16	1	615856	M/F HYD TUBE,MAIN SUP,ST510 07	84	1	615855	HYD RETURN LINE, LONG,ST510 07
17	2	611125	3/4MJIC-3/4MOR ADPTR	85	1	616641	08-4511TC-10FX-08FX90L-178H/A
18	6	618241	3/4MJIC-90-3/4MOR LBO	86	1	616395	08-4511TC-08FX-08FX-23 H/A
19	1	618913	7/8MJIC-90-M22MOR LBO	87	1	616307	16-881-16FX-16FX90-25 H/A
20	2	618249	3/4MJIC-90-9/16MOR LBO	88	1	616319	04-4511TC-04FX-04FX90-52 H/A
21	15	618119	9/16MJIC-90-9/16MOR LBO	89	1	616476	10-4511TC-10FX-12FX90-24 H/A
22	2	618473	7/16MJIC-90-7/16MOR LBO	90	1	618842	1 1/16MJIC-90-1 5/8MOR LBO
23	1	618444	9/16MOR RUN TEE-9/16MJIC	91	1	617004	06-4511TC-08FX-06FX90-21 H/A
24	3	618126	9/16MJIC-9/16MOR ADPTR	92	4	611127	1 1/16MJIC-1 1/16MOR ADPTR
25	2	618753	7/16MOR PLUG, HEX SOCKET	93	1	616404	16-4511TC-16FX-16FX45-40 H/A
26	1	618108	1 1/16MJIC-3/4MNPT ADPTR	94	1	618912	3/4MJIC-90-M18MOR LBO
27	1	618361	7/16MOR-9/16FOR ADPTR	95	1	616322	06-4511TC-08FX-08FX90-21 H/A
28	1	618301	7/8MJIC-90-7/8FJIC SWIV LBO	96	1	616443	08-4511TC-08FX-08FX90-76 H/A
29	1	618759	1 5/8MOR PLUG, HEX SOCKET	97	1	616315	04-4511TC-04FX-04FX45-74 H/A
30	4	618302	1 1/16MJIC-90-1 5/16MOR LBO	98	1	616437	04-4511TC-04FX-06FX90-28 H/A
31	4	618467	7/16MJIC-7/16MOR ADPTR	99	1	616416	10-4511TC-12FX-12FX-25 H/A
32	4	618308	1 1/16MJIC-1 5/16MOR ADPTR	100	1	616445	10-4511TC-10FX-12FX-127 H/A
33	2	618529	1 1/16MJ-45-1 1/16FJ SWIV LBO	101	1	616442	06-4511TC-08FX-08FX90-114 H/A
34	1	618470	3/4MJIC-1 5/16MOR ADPTR	102	1	616439	04-4511TC-06FX-06FX-98 H/A
35	1	618451	3/4FJIC SW RUN TEE-3/4MJIC	103	1	616440	04-4511TC-06FX-06FX90-114 H/A
36	1	618630	1 5/16MJ-45-1 5/16FJ SWIV LBO	104	3	606249	MANIFOLD, TRD ADJ PWRSS
37	1	618731	9/16JIC .025 ORIFICE ADPTR	105	1	616732	10-4511TC-10FX-12FX90-121 H/A
38	1	618486	9/16FJIC SW RUN TEE-9/16MJIC	106	1	618640	1 5/16MJ-90-1 5/16FJ SWIV LBO
39	1	618455	1 5/16MJIC-1 5/8MOR ADPTR	107	1	618171	7/8MOR-3/4FOR ADPTR
40	2	618475	3/4MJIC-90-1 5/16MOR LBO	108	6	618754	9/16MOR PLUG, HEX SOCKET
41	1	618363	7/16FJIC CAP NUT	109	6	618755	3/4MOR PLUG, HEX SOCKET
42	2	618314	3/4MJIC UNION	110	3	618499	7/16MJIC-90-9/16MOR LBO
43	1	618487	1 1/16FJ SW RUN TEE-1 1/16MJ	111	1	618733	9/16JIC .042 ORIFICE ADPTR
44	4	616070	04-4511TC-04M3BH-06MOR-11.00H/A	112	1	606259	DIVERSION VLV,STS LS
45	1	618132	1 1/16MOR-7/8FOR ADPTR	113	2	618474	3/4MJIC-90-1 1/16MOR LBO
46	1	618440	9/16MJIC-90-9/16MOR EX LG LBO	114	1	6181236	3" TRANSFER PUMP, HYPRO
47	1	616446	04-4511ST-06FX-04FX90-131 H/A	115	1	618183	3/4MJIC-90-7/8MOR LBO
48	3	618628	7/8MJIC-45-7/8FJIC SWIV LBO	116	1	690672	HMC 320 SPECIAL/MNUS HOSE
49	1	618325	9/16MJIC-45-9/16MOR LBO	117	2	618770	3/4MJIC-3/4MOR BLKHD ADPT
50	1	618397	1 5/16MOR-9/16FOR ADPTR	118	1	618769	9/16MJIC-9/16MOR BLKHD ADPT
51	3	618191	1 1/16MJ-90-1 1/16FJ SWIV LBO	119	1	618806	HYD CPLR,MALE #12,7/8FOR
52	2	616531	08-4511TC-08FX-08FX-55 H/A	120	1	691036	HYPRO 9307C-GM10 PUMP
53	4	616071	04-4511TC-04M3BH-06MOR-13.00H/A	121	1	616451	12-4511TC-12FX-12FX90-34 H/A
54	1	616504	08-4511TC-08FX-08FX-98 H/A	122	1	616450	10-4511TC-12FX-12FX90-22 H/A
55	1	618807	HYD CPLR, FEM #12,3/4FOR	123	1	611128	7/8MJIC-90-7/8MOR LBO
56	1	616448	10-4511ST-08FX-12FX-119 H/A	124	2	618590	3/4MJIC-45-3/4FJIC SWIV LBO
57	1	618248	1 1/16MJIC-90-1 1/16MOR LBO	125	1	616617	06-4511TC-06FX-06FX-168 H/A
58	1	618273	1 1/16MJIC-1/2MNPT ADPTR	126	1	618774	7/8MJIC-90-7/8MOR LG LBO
59	1	618178	1 5/16MJIC-90-1 5/16MOR LBO	127	1	618883	1 5/16MJIC-90-1 5/8MOR LBO
60	1	618831	1 1/16MJIC-45-1 5/16MOR LBO	128	1	618909	M12 MOR PLUG, HEX SOCKET
61	9	616301	04-4511TC-04FX-06FX-21 H/A	129	1	618910	3/4MJIC-M18MOR ADPTR
62	1	616447	10-4511ST-08FX-12FX90-44 H/A	130	1	617018	16-4511TC-16FX-16FX90-24 H/A
63	1	618805	HYD CPLR, FEM #14,9/16FOR	131	1	617015	10-4511TC-08FX-10FX-177 H/A
64	1	616306	08-4511TC-08FX-08FX-11 H/A	132	1	618535	7/8MJIC-90-1 1/16MOR LBO
65	2	616377	04-4511TC-06FX-06FX90-44 H/A	133	1	617019	06-4511TC-06FX-06FX-285 H/A
66	1	616088	04-4511TC-06FX-06FX-56 H/A	134	1	618557	7/8FJIC-9/16MJIC ADPTR
67	1	616441	06-4511TC-08FX-08FX90-40 H/A				
68	1	616477	12-4511TC-12FX-12FX-34 H/A				

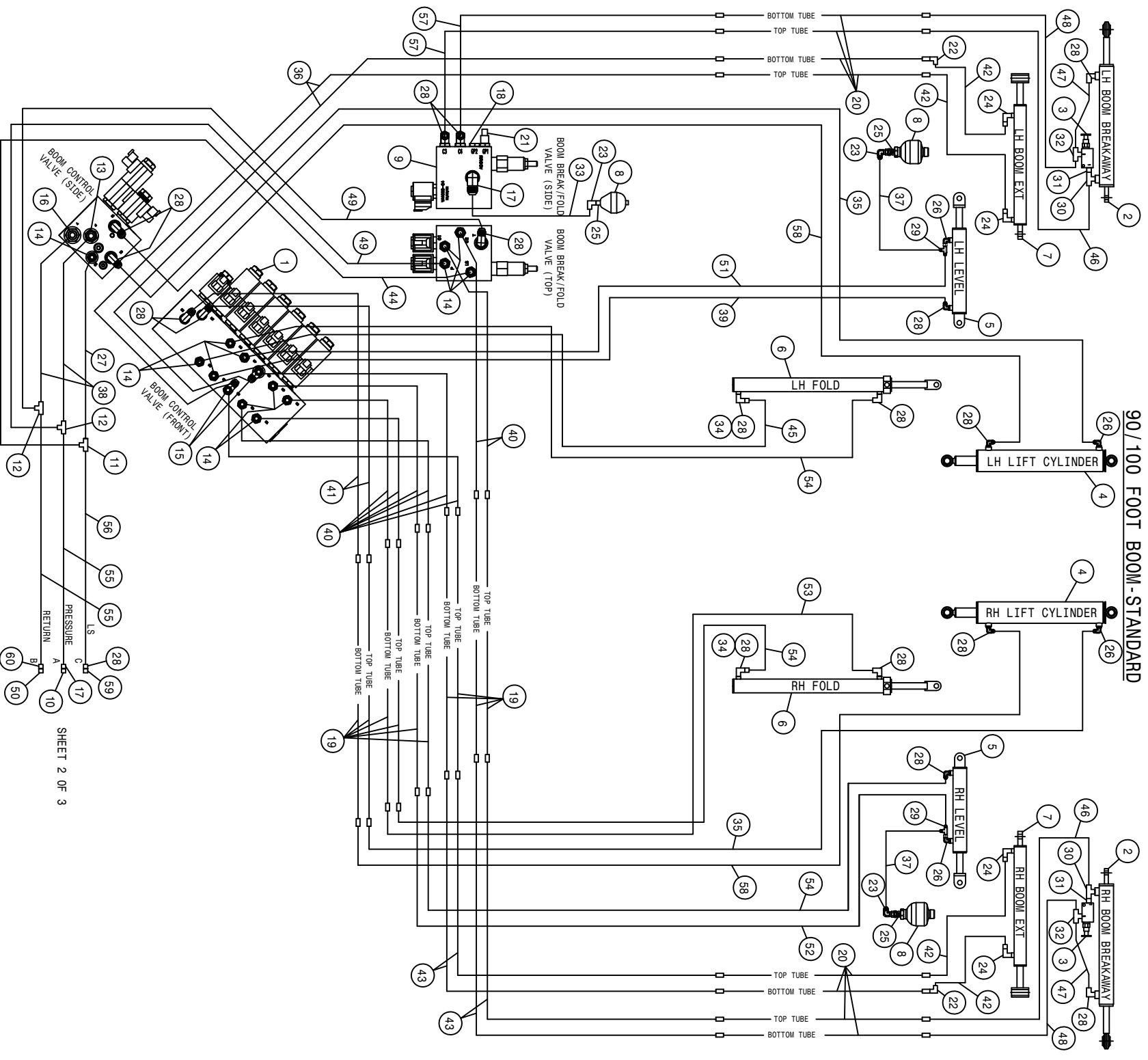

SHEET 2 OF 3

STS 10/12 STANDARD HYDRAULIC DIAGRAM 2012
REFERENCE DRAWING NO. 499244S3

DET.	QTY	PART NO.	DESCRIPTION	DET.	QTY	PART NO.	DESCRIPTION
1	1	606272	VALVE, LOAD SENSE BOOM SAUER	31	2	618668	9/16FJIC SWIV-9/16MOR ADPTR
2	2	621554	HYD CYL, 1.50 X 12.25 X .750	32	2	614752	RESTRICTOR BR TEE ASSY,.042DIA
3	2	607540	KICK-DOWN RELIEF VALVE, 800PSI	33	1	616384	08-451TC-08FJX-08FJX-43 H/A
4	2	621556	HYD CYL, 2.50 X 18.00 X 1.500	34	2	618733	9/16JIC .042 ORIFICE ADPTR
5	2	621558	HYD CYL, 3.00 X 11.00 X 1.380	35	2	616358	06-451TC-06FJX-06FJX-56 H/A
6	2	621560	HYD CYL, 2.50 X 21.00 X 1.380	36	2	616357	06-451TC-06FJX-06FJX90-79 H/A
7	2	621562	HYD CYL, 2.25 X 21.00 X 1.380	37	2	616365	06-451TC-08FJX-06FJX90-30 H/A
8	3	470444	ACCUMULATOR, 30CI 1508 PSI	38	2	616366	08-451TC-08FJX-08FJX90-18 H/A
9	1	606248	90'BREAKAWAY VLV,STS PWRSYS	39	1	616403	06-451TC-06FJX-06FJX-65 H/A
10	1	618807	HYD CPLR, FEM #12, 3/4FOR	40	8	616316	06-451TC-06FJX-06FJX45-18 H/A
11	1	618748	7/16MJIC BLKHD RUN TEE	41	2	616304	06-451TC-06FJX-06FJX-36 H/A
12	2	618749	3/4MJIC BLKHD RUN TEE	42	4	616356	06-451TC-06FJX-06FJX90-27 H/A
13	1	611125	3/4MJIC-3/4MOR ADPTR	43	4	616353	06-451TC-06FJX-06FJX-71 H/A
14	13	618126	9/16MJIC-9/16MOR ADPTR	44	1	616362	04-451TC-04FJX-06FJX90-35 H/A
15	2	618444	9/16MOR RUN TEE-9/16MJIC	45	1	616352	06-451TC-06FJX-06FJX-62 H/A
16	1	618327	3/4MJIC-7/8MOR ADPTR	46	2	616360	06-451TC-06FJX-06FJX-84 H/A
17	2	618241	3/4MJIC-90-3/4MOR LBO	47	2	616075	04-451TC-06FJX-06FJX-9 H/A
18	1	618754	9/16MOR PLUG, HEX SOCKET	48	2	616361	06-451TC-06FJX-06FJX-86 H/A
19	10	615852	LIFTARM HYD TUBE ASSY, STLS 07	49	2	616364	06-451TC-08FJX-06FJX90-31 H/A
20	8	615851	HYD TUBE, MAIN BOOM, STS	50	1	618806	HYD CPLR, MALE #12, 7/8FOR
21	1	606347	PRESSURE TRANSDUCER, 7500PSI	51	1	616349	06-451TC-06FJX-06FJX-47 H/A
22	2	618618	9/16MJIC-90-9/16FJIC SWIV LBO	52	1	616348	06-451TC-06FJX-06FJX-42 H/A
23	3	618609	3/4MJIC-90-3/4FJIC SWIV LBO	53	1	616350	06-451TC-06FJX-06FJX-58 H/A
24	4	618688	9/16MJ-90-9/16MOR .025 CHK VLV	54	3	616351	06-451TC-06FJX-06FJX-60 H/A
25	3	618743	3/4MOR-3/4MJIC BLKHD, .040 ORF	55	2	616135	08-451TC-08FJX-08FJX-50 H/A
26	4	618689	9/16MJ-90-9/16MOR .042 CHK VLV	56	1	616431	04-451TC-04FJX-06FJX-51 H/A
27	1	616430	04-451TC-06FJX-04FJX90-19 H/A	57	2	616359	06-451TC-06FJX-06FJX-78 H/A
28	18	618119	9/16MJIC-90-9/16MOR LBO	58	2	616371	06-451TC-06FJX-06FJX-38 H/A
29	2	618486	9/16FJIC SW RUN TEE-9/16MJIC	59	1	618804	HYD CPLR, MALE #14, 9/16FOR
30	2	618629	9/16MOR BRANCH TEE-9/16MJIC	60	1	618183	3/4MJIC-90-7/8MOR LBO

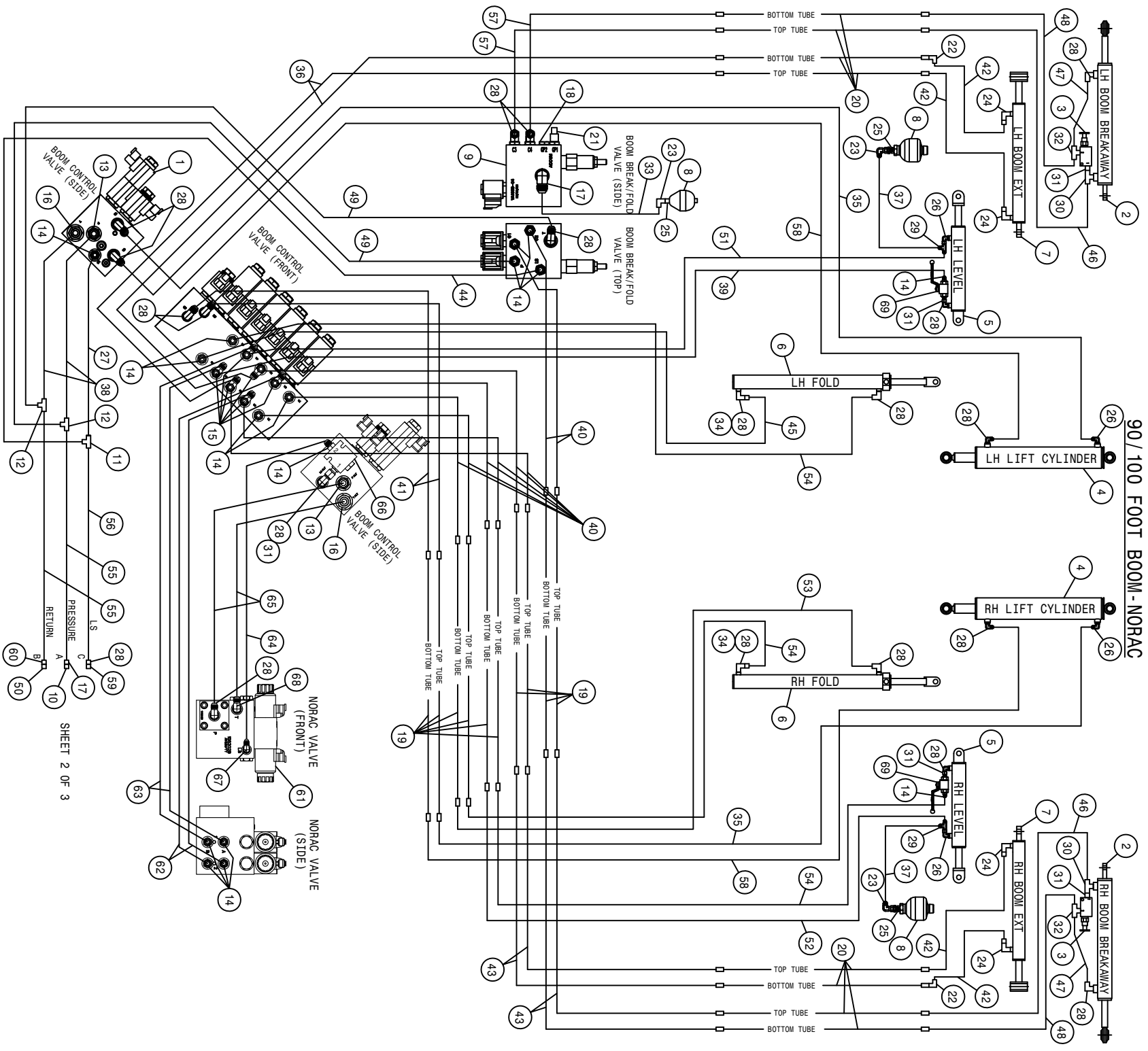

SHEET 2 OF 3

STS 10/12 STANDARD HYDRAULIC DIAGRAM 2012
REFERENCE DRAWING NO. 499244S4

DET.	QTY	PART NO.	DESCRIPTION	DET.	QTY	PART NO.	DESCRIPTION
1	1	606272	VALVE, LOAD SENSE BOOM SAUER	36	2	616357	06-451TC-06FJX-06FJX90-79 H/A
2	2	621554	HYD CYL, 1.50 X 12.25 X .750	37	2	616365	06-451TC-08FJX-06FJX90-30 H/A
3	2	607540	KICK-DOWN RELIEF VALVE, 800PSI	38	2	616366	08-451TC-08FJX-08FJX90-18 H/A
4	2	621556	HYD CYL, 2.50 X 18.00 X 1.500	39	1	616403	06-451TC-06FJX-06FJX-65 H/A
5	2	621558	HYD CYL, 3.00 X 11.00 X 1.380	40	8	616316	06-451TC-06FJX-06FJX45-18 H/A
6	2	621560	HYD CYL, 2.50 X 21.00 X 1.380	41	2	616304	06-451TC-06FJX-06FJX-36 H/A
7	2	621562	HYD CYL, 2.25 X 21.00 X 1.380	42	4	616356	06-451TC-06FJX-06FJX90-27 H/A
8	3	470444	ACCUMULATOR, 30CI 1508 PSI	43	4	616353	06-451TC-06FJX-06FJX-71 H/A
9	1	606248	90°BREAKAWAY VLV,STS PWRSYS	44	1	616362	04-451TC-04FJX-06FJX90-35 H/A
10	1	618807	HYD CPLR, FEM #12,3/4FOR	45	1	616352	06-451TC-06FJX-06FJX-62 H/A
11	1	618748	7/16MJIC BLKHD RUN TEE	46	2	616360	06-451TC-06FJX-06FJX-84 H/A
12	2	618749	3/4MJIC BLKHD RUN TEE	47	2	616075	04-451TC-06FJX-06FJX-9 H/A
13	2	611125	3/4MJIC-3/4MOR ADPTR	48	2	616361	06-451TC-06FJX-06FJX-86 H/A
14	16	618126	9/16MJIC-9/16MOR ADPTR	49	2	616364	06-451TC-08FJX-06FJX90-31 H/A
15	6	618444	9/16MOR RUN TEE-9/16MJIC	50	1	618806	HYD CPLR,MALE #12, 7/8FOR
16	2	618327	3/4MJIC-7/8MOR ADPTR	51	1	616349	06-451TC-06FJX-06FJX-47 H/A
17	2	618241	3/4MJIC-90-3/4MOR LBO	52	1	616348	06-451TC-06FJX-06FJX-42 H/A
18	1	618754	9/16MOR PLUG, HEX SOCKET	53	1	616350	06-451TC-06FJX-06FJX-58 H/A
19	10	615852	LIFTARM HYD TUBE ASSY,STSL5 07	54	3	616351	06-451TC-06FJX-06FJX-60 H/A
20	8	615851	HYD TUBE,MAIN BOOM,STS	55	2	616135	08-451TC-08FJX-08FJX-50 H/A
21	1	606347	PRESSURE TRANSDUCER,7500PSI	56	1	616431	04-451TC-04FJX-06FJX-51 H/A
22	2	618618	9/16MJIC-90-9/16FJIC SWIV LBO	57	2	616359	06-451TC-06FJX-06FJX-78 H/A
23	3	618609	3/4MJIC-90-3/4FJIC SWIV LBO	58	2	616371	06-451TC-06FJX-06FJX-38 H/A
24	4	618688	9/16MJ-90-9/16MOR .025 CHK VLV	59	1	618804	HYD CPLR,MALE #14, 9/16FOR
25	3	618743	3/4MOR-3/4MJIC BLKHD, .040 ORF	60	1	618183	3/4MJIC-90-7/8MOR LBO
26	4	618689	9/16MJ-90-9/16MOR .042 CHK VLV	61	1	606455	NORAC HYD VALVE (44963D)
27	1	616430	04-451TC-06FJX-04FJX90-19 H/A	62	2	616555	06-451TC-06FJX-06FJX90-31 H/A
28	20	618119	9/16MJIC-90-9/16MOR LBO	63	2	616557	06-451TC-06FJX-06FJX90L-31 H/A
29	2	618486	9/16FJIC SW RUN TEE-9/16MJIC	64	1	616554	04-451TC-04FJX-06FJX90-30 H/A
30	2	618629	9/16MOR BRANCH TEE-9/16MJIC	65	2	616556	08-451TC-06FJX-08FJX90-31 H/A
31	5	618668	9/16FJIC SWIV-9/16MOR ADPTR	66	1	606256	CHECK VALVE, IN LINE SAUER
32	2	614752	RESTRICTOR BR TEE ASSY, .042DIA	67	1	618473	7/16MJIC-90-7/16MOR LBO
33	1	616384	08-451TC-08FJX-08FJX-43 H/A	68	1	618440	9/16MJIC-90-9/16MOR EX LG LBO
34	2	618733	9/16JIC .042 ORIFICE ADPTR	69	2	696131	BALL VALVE,9/16FOR,7250PSI
35	2	616358	06-451TC-06FJX-06FJX-56 H/A				

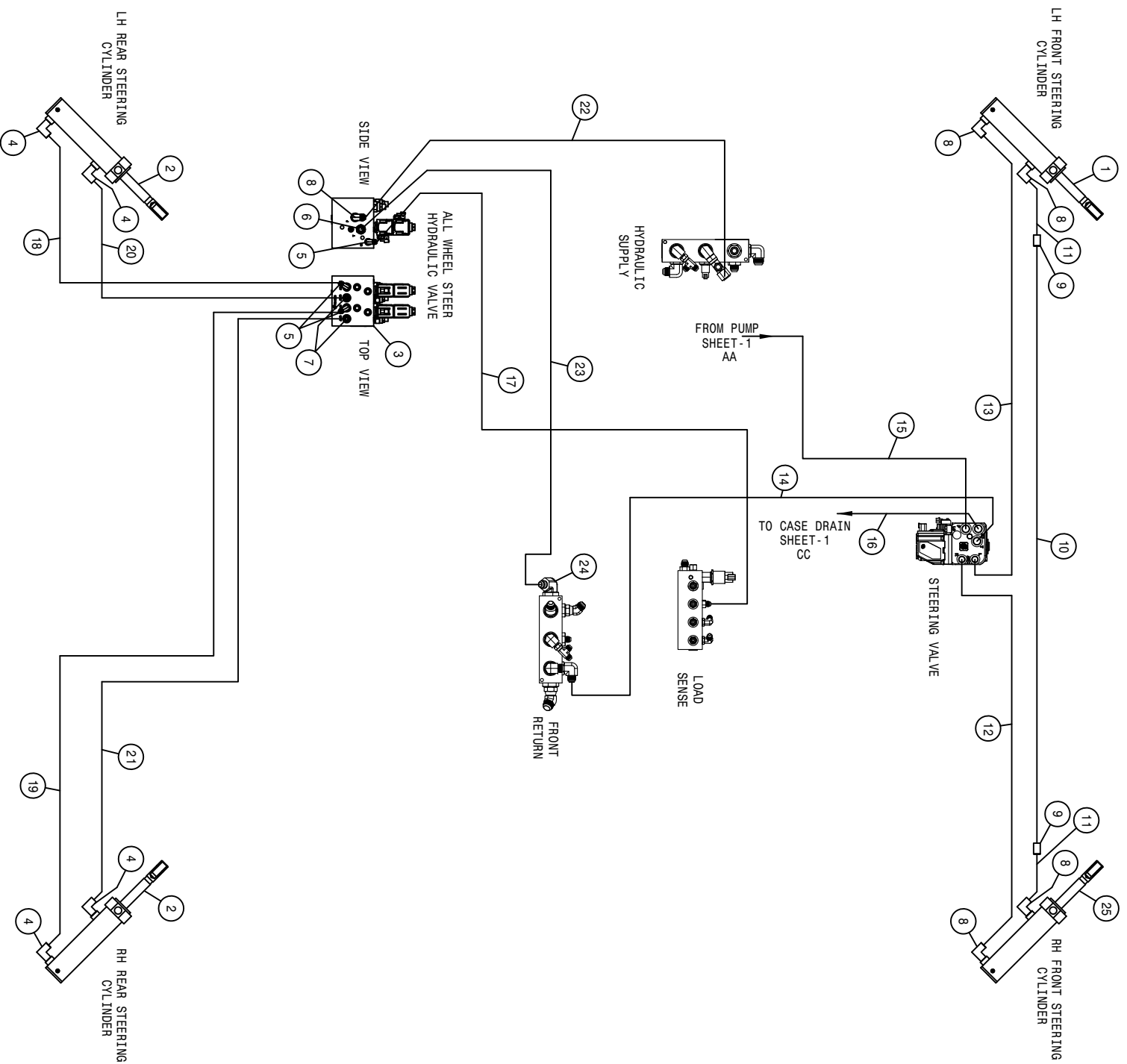

ALL WHEEL STEER DIAGRAM

STS 10/12 STANDARD HYDRAULIC DIAGRAM 2012
REFERENCE DRAWING NO. 499244S5

DET.	QTY	PART NO.	DESCRIPTION	DET.	QTY	PART NO.	DESCRIPTION
1	1	621602	HYD CYL, 2.50 X 8.81 PHASE/1SEN	14	1	617017	10-451TC-10FJX-12FJX90-82 H/A
2	2	621603	HYD CYL, 2.50 X 8.81 W/SENSOR	15	1	617012	06-451TC-06FJX-08FJX90-212 H/A
3	1	606370	VALVE, FV8623 V1 SUNSOURCE	16	1	617015	10-451TC-08FJX-10FJX-177 H/A
4	4	618115	9/16MJIC-90-3/4MOR LBO	17	1	616709	04-451TC-06FJX-04FJX90-93 H/A
5	3	618119	9/16MJIC-90-9/16MOR LBO	18	1	616710	08-451TC-06FJX-06FJX-95 H/A
6	1	611126	7/8MJIC-7/8MOR ADPTR	19	1	616711	08-451TC-06FJX-06FJX-129 H/A
7	2	618126	9/16MJIC-9/16MOR ADPTR	20	1	616712	08-451TC-06FJX-06FJX90-91 H/A
8	5	618241	3/4MJIC-90-3/4MOR LBO	21	1	616713	08-451TC-06FJX-06FJX90-119 H/A
9	2	618314	3/4MJIC UNION	22	1	616714	08-451TC-08FJX-12FJX90-92 H/A
10	1	615772	STRG CYL JUMPER HYD TUBE ASSY	23	1	616715	10-451TC-12FJX-10FJX90-82 H/A
11	2	616531	08-451TC-08FJX-08FJX-55 H/A	24	1	618842	1 1/16MJIC-90-1 5/8MOR LBO
12	1	616504	08-451TC-08FJX-08FJX-98 H/A	25	1	621614	HYD CYL, 2.50 X 8.81 PHASE/2SEN
13	1	616730	08-451TC-08FJX-08FJX90-108 H/A				

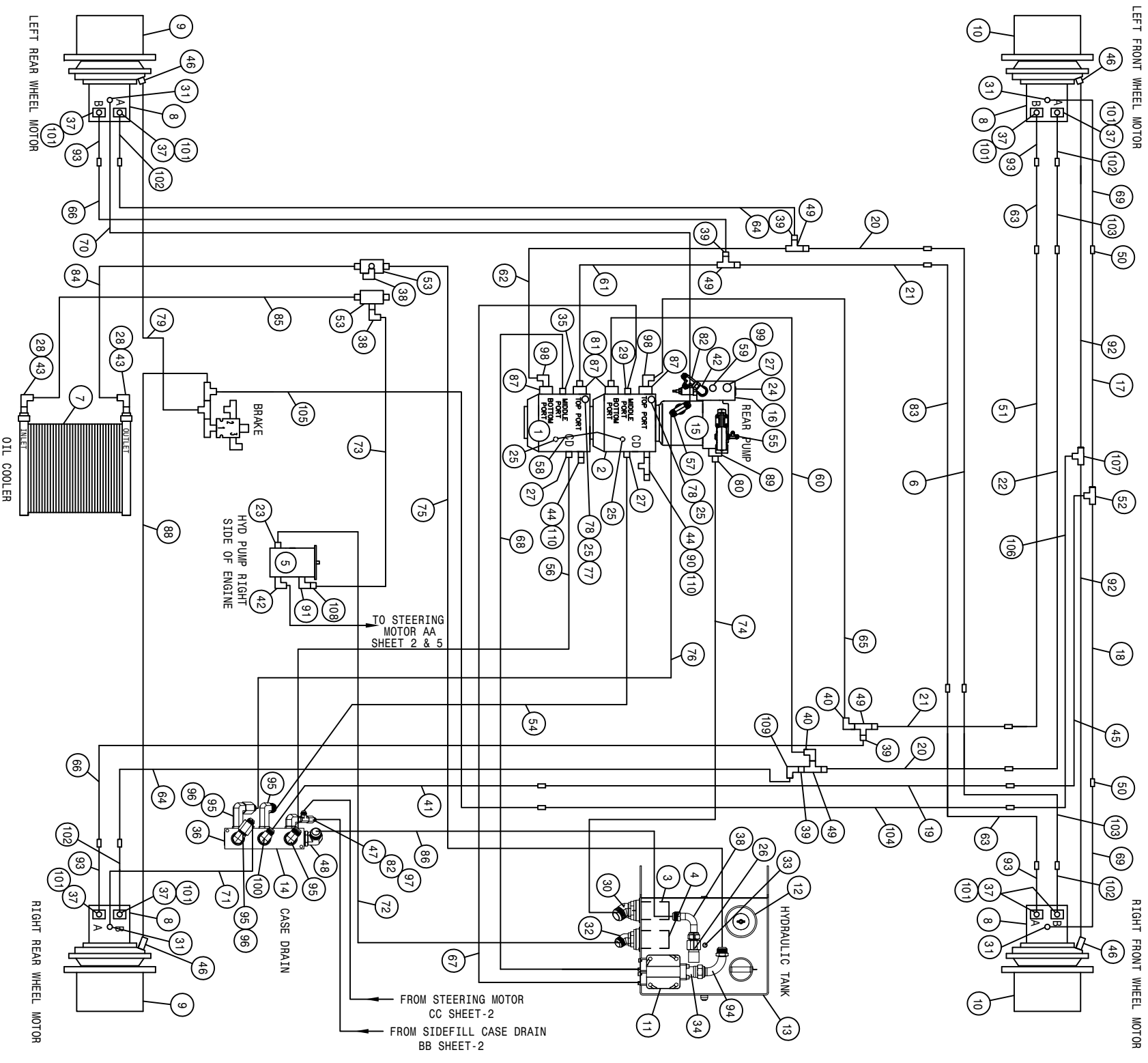

STS 10/12 HI TORQUE HYDRAULIC DIAGRAM 2012
REFERENCE DRAWING NO. 49924551

DET.	QTY	PART NO.	DESCRIPTION	DET.	QTY	PART NO.	DESCRIPTION
1	1	606512	H1-P-115CC PUMP,D/D-MT	56	1	616983	16-451TC-16FJX-16FJX90L-41 H/A
2	1	606513	H1-P-115CC PUMP,D/B-MT	57	1	618130	7/8MOR RUN TEE-7/8MJIC
3	1	605623	SUCTION STRAINER,39GPM 100M 32	58	1	616038	04-471TC-06FJX-06FJX90-15 H/A
4	1	605622	SUCTION STRAINER,21GPM 100M 24	59	1	611126	7/8MJIC-7/8MOR ADPTR
5	1	606450	TANDEM PUMP,606451 & 606452	60	1	616987	20-791TC-20FFOX-20FFOX90-47H/A
6	1	615848	RH FRONT HYDROSTAT TUBE ASSY	61	1	616985	20-791TC-20FFOX-20FFOX-54 H/A
7	1	618800	OIL COOLER STS12	62	1	616988	20-791TC-20FFOX-20FFOX90-68H/A
8	4	606514	H1-B-80CC WHL MTR	63	2	616565	16-7921C-16FFOX-16FFOX-129 H/A
9	2	610507	TORQ HUB,31:1 CW18E	64	2	616359	16-7921C-16FFOX-16FFOX-146 H/A
10	2	610506	TORQ HUB,25:1 CW18E	65	1	616986	20-791TC-20FFOX-20FFOX90-26H/A
11	1	605625	IN-TANK RETURN FILTER, 10M	66	2	616566	16-7921C-16FFOX-16FFOX90-151H/
12	1	605647	BREATHER-HVD RSRVR	67	1	616989	20-881-20FLG-20FJX90-83 H/A
13	1	760732	HYD TANK WLD,STS10/12/14	68	1	616990	20-881-20FLG-20FJX90-96 H/A
14	1	606246	MANIFOLD, #16 3-STN 180	69	2	617050	08-451TC-10FJX-08FJX45-142 H/A
15	1	607004	SAUER PISTON PUMP JRR060B	70	1	616373	08-451TC-10FJX-08FJX45-212 H/A
16	1	606258	REFIEEF, LS PUMP SAUER	71	1	616265	08-451TC-12FJX-08FJX45-175 H/A
17	1	615823	LH FRT CASEDRAIN HYD TUBE ASSY	72	1	616346	24-881-24FJX-24FJX90-103 H/A
18	1	615822	RH FRT CASEDRAIN HYD TUBE ASSY	73	1	616347	16-881-20FJX-16FJX90-59 H/A
19	1	615854	M/F CASE DRAIN TUBE,STS10	74	1	616343	32-881-32FJX-32FJX-53 H/A
20	2	615904	OUTER HYDRO TUBE ASSY,10/12'12	75	1	616399	24-881-20FJX-24FJX90-105 H/A
21	2	615905	INNER HYDST TUBE ASSY,10/12'12	76	1	616982	10-451TC-12FJX-10FJX90-25 H/A
22	1	615849	LH FRONT HYDROSTAT TUBE ASSY	77	1	618735	9/16JIC .062 ORIFICE ADPTR
23	1	618527	1 7/8MJIC-1 5/8MOR ADPTR	78	2	618782	9/16MOR-9/16FOR-9/16MJIC BRNCH
24	1	618753	7/16MOR PLUG, HEX SOCKET	79	1	616073	04-451TC-06FJX-04FJX45-202 H/A
25	4	606196	PRESS TRANSDUCER ASSY 9000PSI	80	1	618765	2" FLANGE-2 1/2MJIC ADPTR #61
26	1	618767	1 7/8FJIC-1 5/8MJIC ADPTR	81	2	618897	1 1/4"FLANGE-1 11/16MFOR ADPTR
27	3	618186	1 5/16MJIC-1 5/16MOR ADPTR	82	2	618451	3/4FJIC SW RUN TEE-3/4MJIC
28	2	618640	1 5/16MJ-90-1 5/16FJ SWIV LBO	83	1	615885	RH FRT WHL MAIN TUBE ASSY,STS09
29	1	618472	1 5/8MJIC-1 5/8MOR ADPTR	84	1	616398	20-881-16FJX-20FJX-83 H/A
30	1	618746	2 1/2MJIC-45-2 1/2MOR LBO	85	1	616397	20-881-16FJX-20FJX-77 H/A
31	4	618602	3/4MJIC-45-7/8MOR LBO	86	1	616396	20-881-20FJX-20FJX90-70 H/A
32	1	618745	1 7/8MJIC-45-1 7/8MOR LBO	87	8	618780	1 1/4 SPLIT FLANGE HALF, #62
33	1	470471	1 5/16MOR PLUG, MAGNETIC	88	1	616372	04-451TC-06FJX-04FJX45-222 H/A
34	1	618747	1 1/2 FLANGE-1 7/8MJIC ADPTR	89	1	618766	2" SPLIT FLANGE KIT #61
35	1	618724	1 5/8MJIC-1 5/8MOR LG ADPTR	90	1	618486	9/16FJIC SW RUN TEE-9/16MJIC
36	1	618759	1 5/8MOR PLUG, HEX SOCKET	91	1	618279	1 1/16MJIC-90-7/8MOR LBO
37	8	618652	1" SPLIT FLANGE KIT	92	2	616072	04-451TC-06FJX-04FJX45-195 H/A
38	3	618768	1 5/8MJIC-90-1 5/8FJX TUBE	93	4	615908	WHL MTR HYD TUBE ASSY STS'12
39	4	618785	1 11/16FOR-1 7/16FOR ADPTR	94	1	618764	1 7/8MJIC-90-1 7/8FJX TUBE LBO
40	2	618895	1 11/16FOR-90-1 11/16FFOX ADP	95	4	618463	1 5/16MJIC-90-1 5/16MOR XL LBO
41	1	616444	10-451TC-12FJX-12FJX90-48 H/A	96	2	618541	1 5/16FJIC-1 1/16MJIC ADPTR
42	2	618183	3/4MJIC-90-7/8MOR LBO	97	1	618482	3/4FJIC-9/16MJIC ADPTR
43	2	618830	1 5/16MJ-1 5/16MOR 6. OLG ADPTR	98	2	618779	1 11/16FOR-90-1 1/4FLG C62LBO
44	2	618126	9/16MJIC-9/16MOR ADPTR	99	1	618333	7/8FJIC SW RUN TEE-7/8MJIC
45	1	616388	10-451TC-12FJX-10FJX90-91 H/A	100	1	618302	1 1/16MJIC-90-1 5/16MOR LBO
46	4	618473	7/16MJIC-90-7/16MOR LBO	101	8	618654	1" FLANGE-90-1 7/16MFOR LBO
47	1	618475	3/4MJIC-90-1 5/16MOR LBO	102	4	615909	WHL MTR TUBE ASSY STS'12
48	1	618477	1 5/8MJIC-90-1 5/8MOR LBO	103	2	616338	16-7921C-16FFOX-16FFOX-127 H/A
49	4	618778	1 11/16FFOX RUNTEE-1 11/16MFOR	104	1	615910	FRONT BRAKE TUBE,STS10/12 '12
50	2	618456	7/8MJIC UNION	105	1	616375	04-451TC-06FJX-08FJX-68 H/A
51	1	615886	LH FRT WHL MAIN TUBE ASY,STS09	106	1	616380	04-451TC-08FJX-06FJX90-85 H/A
52	1	618581	7/8MJIC UNION TEE	107	1	618019	9/16MJIC UNION TEE
53	2	618752	1 5/8MJIC BLKHD RUN TEE	108	1	618641	1 1/16FJIC-1 5/16MJIC ADPTR
54	1	616984	16-451TC-16FJX-16FJX90-45 H/A	109	1	618362	1 7/16MFOR-90-1 7/16FFOR LBO
55	1	618509	7/16MOR RUN TEE-7/16MJIC	110	2	618531	9/16FJIC CAP NUT

STS 10/12 HI TORQUE HYDRAULIC DIAGRAM 2012
REFERENCE DRAWING NO. 499245S2

DET.	QTY	PART NO.	DESCRIPTION	DET.	QTY	PART NO.	DESCRIPTION
1	1	749333	STRG CTRL VLV, OSPEDC 60/260	69	1	617012	06-451TC-06FCX-08FCX90-.212 H/A
2	1	621550	HYD CYL, 2.50 X 8.81 X 1.250	70	1	616308	10-451TC-10FCX-12FCX-12 H/A
3	1	606247	MANIFOLD W/CHK VLV SAUER	71	1	616320	04-451TC-04FCX-04FCX90-.47 H/A
4	2	606246	MANIFOLD, #16 3-STN 180	72	1	616435	04-451TC-06FCX-04FCX45-.20 H/A
5	1	621614	HYD CYL, 2.50 X 8.81 PHASE/2SEN	73	1	616310	10-451TC-10FCX-12FCX-24 H/A
6	2	621552	HYD CYL, 1.50 X 12.25 X .750	74	1	616341	16-881-16FCX-20FCX-51 H/A
7	4	621152	HYD PUMP, 3.00 X 16.00 X 1.375	75	1	616330	10-451TC-12FCX-12FCX90-.87 H/A
8	1	691160	HYPRO CYLMP, 9306C-HM5C-BU,FLG	76	1	616438	04-451TC-04FCX-04FCX45-.51 H/A
9	1	606213	HYD SOLE VLV, 2P-3W, 9/16FOR 05	77	1	616327	10-451TC-10FCX-10FCX90-.44 H/A
10	1	606253	CTRL VALVE, SOLU PUMP SAUER	78	1	617017	10-451TC-10FCX-12FCX90-.82 H/A
11	2	606347	PRESSURE TRANSDUCER, 7500PSI	79	2	618911	7/8MJIC-M22 MOR ADPTR
12	1	615772	STRG CYL JUMPER HYD TUBE ASSY	80	2	618533	1 1/16FCJIC CAP NUT
13	1	615850	M/F HYD TUBE, LS LINE, STS10 07	81	1	616406	16-881-20FCX-16FCX90-122 H/A
14	2	615853	M/F HYD TUBE, PRES,RTN STS10 07	82	1	616326	08-451TC-08FCX-10FCX90-.48 H/A
15	1	618629	9/16MOR BRANCH TEE-9/16MJIC	83	1	616730	08-451TC-08FCX-08FCX90-108 H/A
16	1	615856	M/F HYD TUBE,MAIN SUP, STS10 07	84	1	615855	HYD RETURN LINE, LONG, STS10 07
17	2	611125	3/4MJIC-3/4MOR ADPTR	85	1	616641	08-451TC-10FCX-08FCX90L-178H/A
18	6	618241	3/4MJIC-90-3/4MOR LBO	86	1	616307	08-451TC-08FCX-08FCX-23 H/A
19	1	618913	7/8MJIC-90-M22MOR LBO	87	1	616309	16-881-16FCX-16FCX90-25 H/A
20	2	618249	3/4MJIC-90-9/16MOR LBO	88	1	616319	04-451TC-04FCX-04FCX90-.32 H/A
21	15	618119	9/16MJIC-90-9/16MOR LBO	89	1	616476	10-451TC-10FCX-12FCX90-.24 H/A
22	2	618473	7/16MJIC-90-7/16MOR LBO	90	1	618842	1 1/16MJIC-90-1 5/8MOR LBO
23	1	618444	9/16MOR RUN TEE-9/16MJIC	91	1	617004	06-451TC-08FCX-06FCX90-.21 H/A
24	3	618126	9/16MJIC-9/16MOR ADPTR	92	4	611127	1 1/16MJIC-1 1/16MOR ADPTR
25	2	618753	7/16MOR PLUG, HEX SOCKET	93	1	616404	16-451TC-16FCX-16FCX45-.40 H/A
26	1	618108	1 1/16MJIC-3/4MNPT ADPTR	94	1	618912	3/4MJIC-90-M18MOR LBO
27	1	618361	7/16MOR-9/16FOR ADPTR	95	1	616322	06-451TC-08FCX-08FCX90-.21 H/A
28	1	618301	7/8MJIC-90-7/8FCJIC SWIV LBO	96	1	616443	08-451TC-08FCX-08FCX90-.76 H/A
29	1	618759	1 5/8MOR PLUG, HEX SOCKET	97	1	616315	04-451TC-04FCX-04FCX45-.74 H/A
30	4	618302	1 1/16MJIC-90-1 5/16MOR LBO	98	1	616437	04-451TC-04FCX-06FCX90-.28 H/A
31	4	618467	7/16MJIC-7/16MOR ADPTR	99	1	616416	10-451TC-12FCX-12FCX-25 H/A
32	4	618308	1 1/16MJIC-1 5/16MOR ADPTR	100	1	616445	10-451TC-10FCX-12FCX-127 H/A
33	2	618529	1 1/16MJIC-45-1 1/16FCJ SWIV LBO	101	1	616442	06-451TC-08FCX-08FCX90-114 H/A
34	1	618470	3/4MJIC-1 5/16MOR ADPTR	102	1	616439	04-451TC-06FCX-06FCX-98 H/A
35	1	618451	3/4FCJIC SW RUN TEE-3/4MJIC	103	1	616440	04-451TC-06FCX-06FCX90-114 H/A
36	1	618630	1 5/16MJIC-45-1 5/16FCJ SWIV LBO	104	3	606249	MANIFOLD, TRD ADJ PWRS
37	1	618731	9/16JIC .025 ORIFICE ADPTR	105	1	616732	10-451TC-10FCX-12FCX90-121 H/A
38	2	618486	9/16FCJIC SW RUN TEE-9/16MJIC	106	1	618640	1 5/16MJIC-90-1 5/16FCJ SWIV LBO
39	1	618455	1 5/16MJIC-1 5/8MOR ADPTR	107	1	618171	7/8MOR-3/4FOR ADPTR
40	2	618475	3/4MJIC-90-1 5/16MOR LBO	108	6	618754	9/16MOR PLUG, HEX SOCKET
41	1	618363	7/16FCJIC CAP NUT	109	6	618755	3/4MOR PLUG, HEX SOCKET
42	2	618314	3/4MJIC UNION	110	3	618499	7/16MJIC-90-9/16MOR LBO
43	1	618487	1 1/16FCJ SW RUN TEE-1 1/16MJ	111	1	618733	9/16JIC .042 ORIFICE ADPTR
44	4	616070	04-451TC-04MJBH-06MOR-11.00H/A	112	1	606259	DIVERSION VLV, STS LS 07
45	1	618132	1 1/16MOR-7/8FOR ADPTR	113	2	618474	3/4MJIC-90-1 1/16MOR LBO
46	1	618440	9/16MJIC-90-9/16MOR EX LG LBO	114	1	691236	3" TRANSFER PUMP, HYPRO
47	1	616446	04-451ST-06FCX-04FCX90-131 H/A	115	1	618183	3/4MJIC-90-7/8MOR LBO
48	3	618628	7/8MJIC-45-7/8FCJIC SWIV LBO	116	1	690672	HMC 320 SPECIAL/MINUS HOSE
49	1	618397	9/16MJIC-45-9/16MOR LBO	117	2	618769	3/4MJIC-3/4MOR BLKHD ADPT
50	1	618395	1 5/16MOR-9/16FOR ADPTR	118	1	618769	9/16MJIC-9/16MOR BLKHD ADPT
51	3	618191	1 1/16MJIC-90-1 1/16FCJ SWIV LBO	119	1	618806	HYD CPLR, MALE #12, 7/8FOR
52	2	616531	08-451TC-08FCX-08FCX-55 H/A	120	1	691036	HYPRO 9307C-GM10 PUMP
53	4	616071	04-451TC-04MJBH-06MOR-13.00H/A	121	1	616451	12-451TC-12FCX-12FCX90-.34 H/A
54	1	616504	08-451TC-08FCX-08FCX-98 H/A	122	1	616450	10-451TC-12FCX-12FCX90-.22 H/A
55	1	618807	HYD CPLR, FEM #12, 3/4FOR	123	1	611128	7/8MJIC-90-7/8MOR LBO
56	1	616448	10-451ST-08FCX-12FCX-119 H/A	124	2	618590	3/4MJIC-45-3/4FCJIC SWIV LBO
57	1	618248	1 1/16MJIC-90-1 1/16MOR LBO	125	1	616617	06-451TC-06FCX-06FCX-168 H/A
58	1	618273	1 1/16MJIC-90-1 1/2MNPT ADPTR	126	1	618774	7/8MJIC-90-7/8MOR LG LBO
59	1	618178	1 5/16MJIC-90-1 5/16MOR LBO	127	1	618883	1 5/16MJIC-90-1 5/8MOR LBO
60	1	618831	1 1/16MJIC-45-1 5/16MOR LBO	128	1	618909	M12 MOR PLUG, HEX SOCKET
61	9	616301	04-451TC-04FCX-06FCX-21 H/A	129	1	618910	3/4MJIC-M18MOR ADPTR
62	1	616447	10-451ST-08FCX-12FCX90-44 H/A	130	1	617018	16-451TC-16FCX-16FCX90-.24 H/A
63	1	618805	HYD CPLR, FEM #14, 9/16FOR	131	1	617015	10-451TC-08FCX-10FCX-177 H/A
64	1	616306	08-451TC-08FCX-08FCX-11 H/A	132	1	618535	7/8MJIC-90-1 1/16MOR LBO
65	2	616377	04-451TC-06FCX-06FCX90-44 H/A	133	1	617019	06-451TC-06FCX-06FCX-285 H/A
66	1	616088	04-451TC-06FCX-06FCX-56 H/A	134	1	618557	7/8FCJIC-9/16MJIC ADPTR
67	1	616441	06-451TC-08FCX-08FCX90-40 H/A				
68	1	616477	12-451TC-12FCX-12FCX-34 H/A				

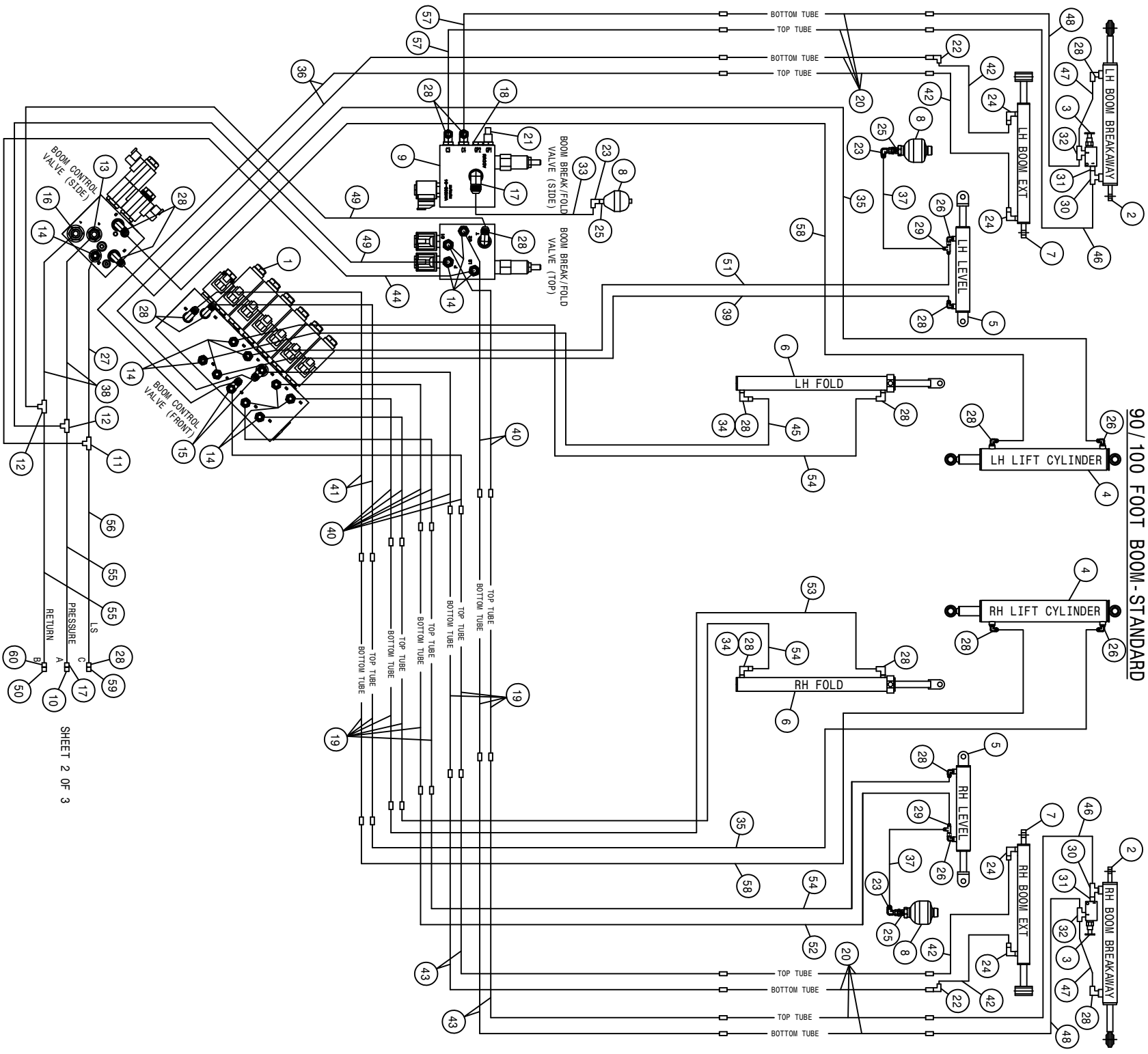

SHEET 2 OF 3

STS 10/12 HI TORQUE HYDRAULIC DIAGRAM 2012
REFERENCE DRAWING NO. 499245S3

DET.	QTY	PART NO.	DESCRIPTION	DET.	QTY	PART NO.	DESCRIPTION
1	1	606272	VALVE, LOAD SENSE BOOM SAUER	31	2	618668	9/16FJIC SWIV-9/16MOR ADPTR
2	2	621554	HYD CYL, 1.50 X 12.25 X .750	32	2	614752	RESTRICTOR BR TEE ASSY, .042D1A
3	2	607540	KICK-DOWN RELIEF VALVE, 800PSI	33	1	616384	08-451TC-.08FJX-.08FJX-43
4	2	621556	HYD CYL, 2.50 X 18.00 X 1.500	34	2	618733	9/16JIC-.042 ORFICE ADPTR
5	2	621558	HYD CYL, 3.00 X 11.00 X 1.380	35	2	616358	06-451TC-.06FJX-.06FJX-56
6	2	621560	HYD CYL, 2.50 X 21.00 X 1.380	36	2	616357	06-451TC-.06FJX-.06FJX90-79
7	2	621562	HYD CYL, 2.25 X 21.00 X 1.380	37	2	616365	06-451TC-.08FJX-.06FJX90-30
8	3	470444	ACCUMULATOR, 30CI 1508 PSI	38	2	616366	08-451TC-.08FJX-.08FJX90-18
9	1	606248	90° BREAKAWAY VLV, STS PMSRSYS	39	1	616403	06-451TC-.06FJX-.06FJX-65
10	1	618807	HYD CPLR, FEM #12, 3/4FOR	40	8	616316	06-451TC-.06FJX-.06FJX45-18
11	1	618748	7/16MJIC BLKHD RUN TEE	41	2	616304	06-451TC-.06FJX-.06FJX-36
12	2	618749	3/4MJIC BLKHD RUN TEE	42	4	616356	06-451TC-.06FJX-.06FJX90-27
13	1	611125	3/4MJIC-3/4MOR ADPTR	43	4	616353	06-451TC-.06FJX-.06FJX-71
14	13	618126	9/16MJIC-9/16MOR ADPTR	44	1	616362	04-451TC-.04FJX-.06FJX90-35
15	2	618444	9/16MOR RUN TEE-9/16MJIC	45	1	616352	06-451TC-.06FJX-.06FJX-62
16	1	618327	3/4MJIC-7/8MOR ADPTR	46	2	616360	06-451TC-.06FJX-.06FJX-84
17	2	618241	3/4MJIC-90-3/4MOR LBO	47	2	616075	04-451TC-.06FJX-.06FJX-9
18	1	618754	9/16MOR PLUG, HEX SOCKET	48	2	616361	06-451TC-.06FJX-.06FJX-86
19	10	615852	LIFTARM HYD TUBE ASSY, STSLS 07	49	2	616364	06-451TC-.08FJX-.06FJX90-31
20	8	615851	HYD TUBE, MAIN BOOM, STS	50	1	618806	HYD CPLR, MALE #12, 7/8FOR
21	1	606347	PRESSURE TRANSDUCER, 7500PSI	51	1	616349	06-451TC-.06FJX-.06FJX-47
22	2	618618	9/16MJIC-90-9/16FJIC SWIV LBO	52	1	616348	06-451TC-.06FJX-.06FJX-42
23	3	618609	3/4MJIC-90-3/4FJIC SWIV LBO	53	1	616350	06-451TC-.06FJX-.06FJX-58
24	4	618688	9/16MJ-90-9/16MOR .025 CHK VLV	54	3	616351	06-451TC-.06FJX-.06FJX-60
25	3	618743	3/4MOR-3/4MJIC BLKHD, .040 ORF	55	2	616135	08-451TC-.08FJX-.08FJX-50
26	4	618689	9/16MJ-90-9/16MOR .042 CHK VLV	56	1	616431	04-451TC-.04FJX-.06FJX-51
27	1	616430	04-451TC-.06FJX-.04FJX90-19 H/A	57	2	616359	06-451TC-.06FJX-.06FJX-78
28	18	618119	9/16MJIC-90-9/16MOR LBO	58	2	616371	06-451TC-.06FJX-.06FJX-38
29	2	618486	9/16FJIC SW RUN TEE-9/16MJIC	59	1	618804	HYD CPLR, MALE #14, 9/16FOR
30	2	618629	9/16MOR BRANCH TEE-9/16MJIC	60	1	618183	3/4MJIC-90-7/8MOR LBO

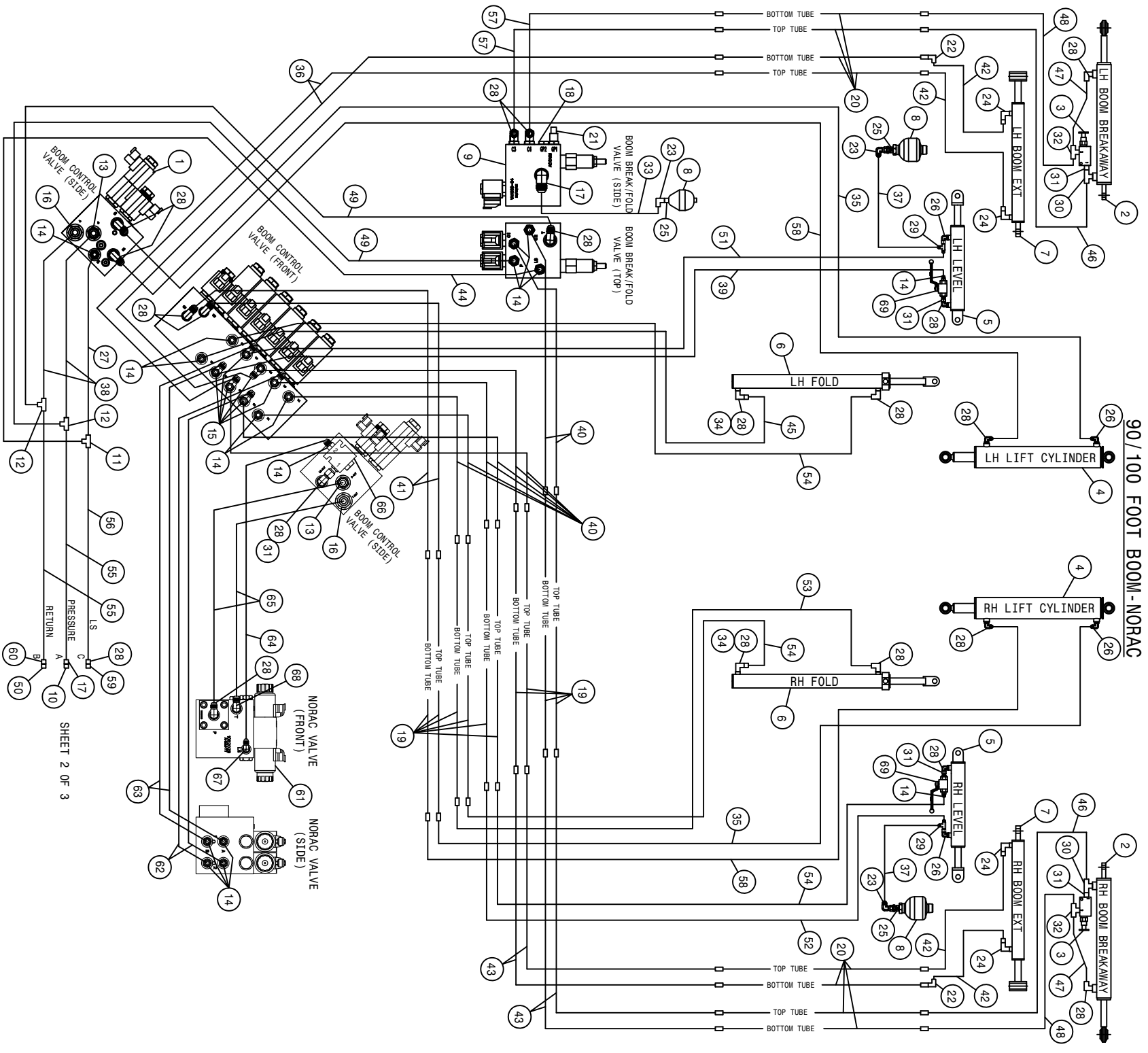

SHEET 2 OF 3

STS 10/12 HI TORQUE HYDRAULIC DIAGRAM 2011
REFERENCE DRAWING NO. 499245S4

DET.	QTY	PART NO.	DESCRIPTION	DET.	QTY	PART NO.	DESCRIPTION
1	1	606272	VALVE, LOAD SENSE BOOM SAUER	36	2	616357	06-451TC-06FJX-06FJX90-79 H/A
2	2	621554	HYD CYL, 1.50 X 12.25 X .750	37	2	616365	06-451TC-08FJX-06FJX90-30 H/A
3	2	607540	KICK-DOWN RELIEF VALVE, 800PSI	38	2	616366	08-451TC-08FJX-08FJX90-18 H/A
4	2	621556	HYD CYL, 2.50 X 18.00 X 1.500	39	1	616403	06-451TC-06FJX-06FJX90-65 H/A
5	2	621558	HYD CYL, 3.00 X 11.00 X 1.380	40	8	616316	06-451TC-06FJX-06FJX45-18 H/A
6	2	621560	HYD CYL, 2.50 X 21.00 X 1.380	41	2	616304	06-451TC-06FJX-06FJX-36 H/A
7	2	621562	HYD CYL, 2.25 X 21.00 X 1.380	42	4	616356	06-451TC-06FJX-06FJX90-27 H/A
8	3	470444	ACCUMULATOR, 30CI 1508 PSI	43	4	616353	06-451TC-06FJX-06FJX-71 H/A
9	1	606248	90°BREAKAWAY VLV,STS PWRSYS	44	1	616362	04-451TC-04FJX-06FJX90-35 H/A
10	1	618807	HYD CPLR, FEM #12,3/4FOR	45	1	616352	06-451TC-06FJX-06FJX-62 H/A
11	1	618748	7/16MJIC BLKHD RUN TEE	46	2	616360	06-451TC-06FJX-06FJX-84 H/A
12	2	618749	3/4MJIC BLKHD RUN TEE	47	2	616075	04-451TC-06FJX-06FJX-9 H/A
13	2	611125	3/4MJIC-3/4MOR ADPTR	48	2	616361	06-451TC-06FJX-06FJX-86 H/A
14	2	618126	9/16MJIC-9/16MOR ADPTR	49	2	616364	06-451TC-08FJX-06FJX90-31 H/A
15	6	618444	9/16MOR RUN TEE-9/16MJIC	50	1	618806	HYD CPLR, MALE #12, 7/8FOR
16	2	618327	3/4MJIC-7/8MOR ADPTR	51	1	616349	06-451TC-06FJX-06FJX-47 H/A
17	2	618241	3/4MJIC-90-3/4MOR LBO	52	1	616348	06-451TC-06FJX-06FJX-42 H/A
18	1	618754	9/16MOR PLUG, HEX SOCKET	53	1	616350	06-451TC-06FJX-06FJX-58 H/A
19	10	615852	LIFTARM HYD TUBE ASSY,STLS 07	54	3	616351	06-451TC-06FJX-06FJX-60 H/A
20	8	615851	HYD TUBE,MAIN BOOM,STS	55	2	616135	08-451TC-08FJX-08FJX-50 H/A
21	1	606347	PRESSURE TRANSDUCER,7500PSI	56	2	616431	04-451TC-04FJX-06FJX-51 H/A
22	2	618618	9/16MJIC-90-9/16FJIC SWIV LBO	57	2	616359	06-451TC-06FJX-06FJX-78 H/A
23	3	618609	3/4MJIC-90-3/4FJIC SWIV LBO	58	2	616371	06-451TC-06FJX-06FJX-38 H/A
24	4	618688	9/16MJ-90-9/16MOR .025 CHK VLV	59	1	618804	HYD CPLR, MALE #14, 9/16FOR
25	3	618743	3/4MOR-3/4MJIC BLKHD, .040 ORF	60	1	618183	3/4MJIC-90-7/8MOR LBO
26	4	618689	9/16MJ-90-9/16MOR .042 CHK VLV	61	1	606455	NORAC HYD VALVE (44963D)
27	1	616430	04-451TC-06FJX-04FJX90-19 H/A	62	2	616555	06-451TC-06FJX-06FJX90-31 H/A
28	20	618119	9/16MJIC-90-9/16MOR LBO	63	2	616557	06-451TC-06FJX-06FJX90L-31 H/A
29	2	618486	9/16FJIC SW RUN TEE-9/16MJIC	64	1	616554	04-451TC-04FJX-06FJX90-30 H/A
30	2	618629	9/16MOR BRANCH TEE-9/16MJIC	65	2	616556	08-451TC-06FJX-08FJX90-31 H/A
31	5	618668	9/16FJIC SWIV-9/16MOR ADPTR	66	1	606256	CHECK VALVE, IN LINE SAUER
32	2	614752	RESTRICTOR BR TEE ASSY, .042DIA	67	1	618473	7/16MJIC-90-7/16MOR LBO
33	1	616384	08-451TC-08FJX-08FJX-43 H/A	68	1	618440	9/16MJIC-90-9/16MOR EX LG LBO
34	2	618733	9/16JIC .042 ORIFICE ADPTR	69	2	696131	BALL VALVE, 9/16FOR, 7250PSI
35	2	616358	06-451TC-06FJX-06FJX-56 H/A				

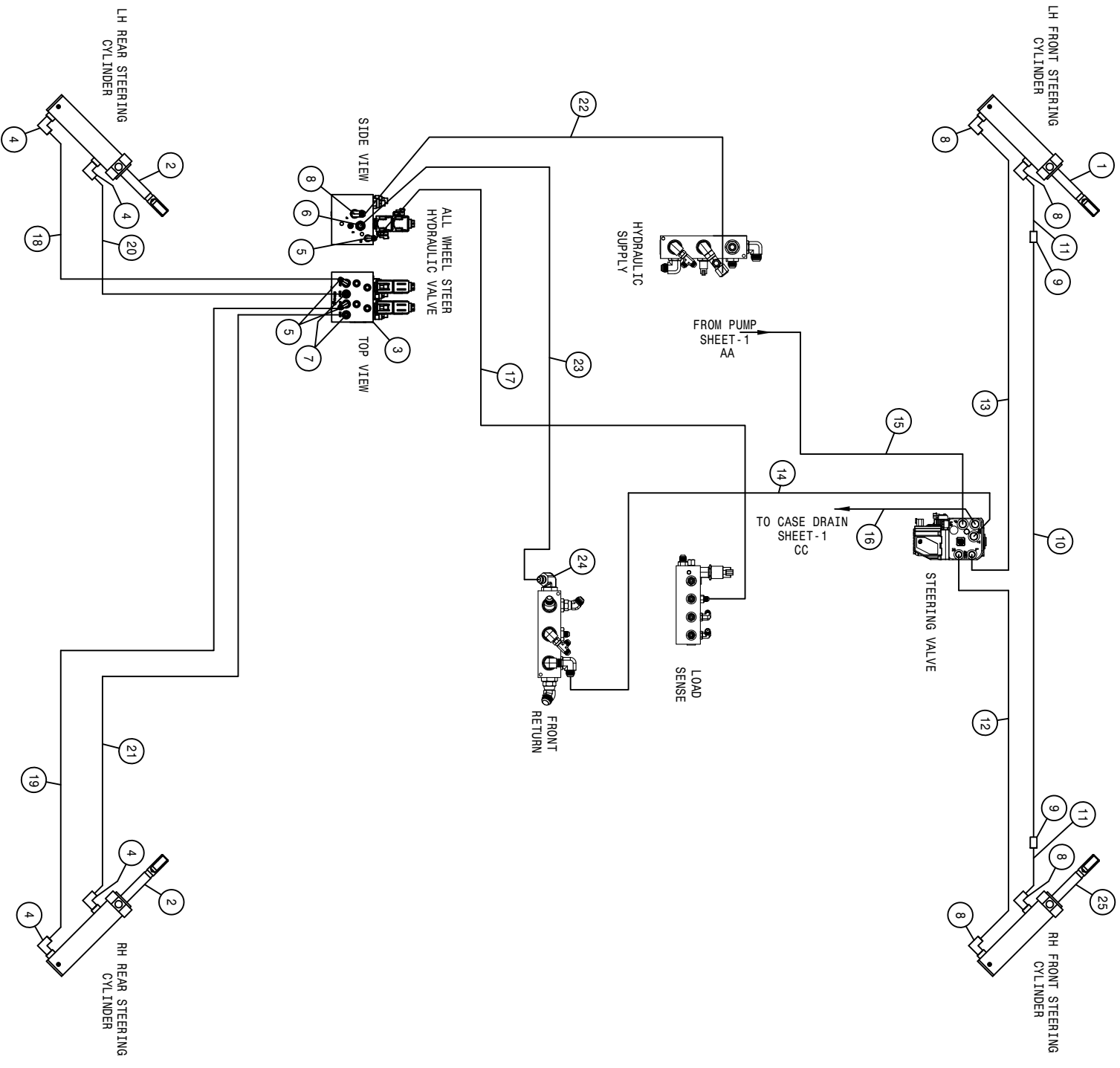

ALL WHEEL STEER DIAGRAM

STS 10/12 HI TORQUE HYDRAULIC DIAGRAM 2012
REFERENCE DRAWING NO. 49924555

DET.	QTY	PART NO.	DESCRIPTION	DET.	QTY	PART NO.	DESCRIPTION
1	1	621602	HYD CYL,2.50 X 8.81 PHASE/1SEN	14	1	617017	10-451TC-10F3X-12F3X90-82 H/A
2	2	621603	HYD CYL,2.50 X 8.81 W/SENSOR	15	1	617012	06-451TC-06F3X-08F3X90-212 H/A
3	1	606370	VALVE, FV8623 V1 SUNSOURCE	16	1	617015	10-451TC-08F3X-10F3X-177 H/A
4	4	618115	9/16MJIC-90-3/4MOR LBO	17	1	616709	04-451TC-06F3X-04F3X90-93 H/A
5	3	618119	9/16MJIC-90-9/16MOR LBO	18	1	616710	08-451TC-06F3X-06F3X-95 H/A
6	1	611126	7/8MJIC-7/8MOR ADPTR	19	1	616711	08-451TC-06F3X-06F3X-129 H/A
7	2	618126	9/16MJIC-9/16MOR ADPTR	20	1	616712	08-451TC-06F3X-06F3X90-91 H/A
8	5	618241	3/4MJIC-90-3/4MOR LBO	21	1	616713	08-451TC-06F3X-06F3X90-119 H/A
9	2	618314	3/4MJIC UNION	22	1	616714	08-451TC-08F3X-12F3X90-92 H/A
10	1	615772	STRG CYL JUMPER HYD TUBE ASSY	23	1	616715	10-451TC-12F3X-10F3X90-82 H/A
11	2	616531	08-451TC-08F3X-08F3X-55 H/A	24	1	618842	1 1/16MJIC-90-1 5/8MOR LBO
12	1	616504	08-451TC-08F3X-08F3X-98 H/A	25	1	621614	HYD CYL,2.50 X 8.81 PHASE//2SEN
13	1	616730	08-451TC-08F3X-08F3X90-108 H/A				

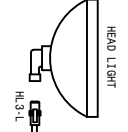
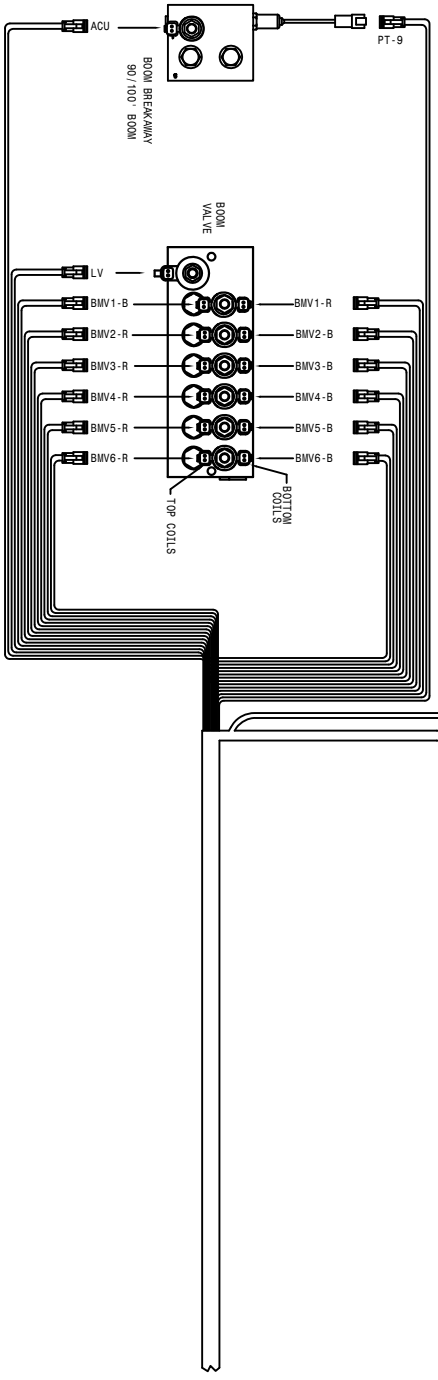
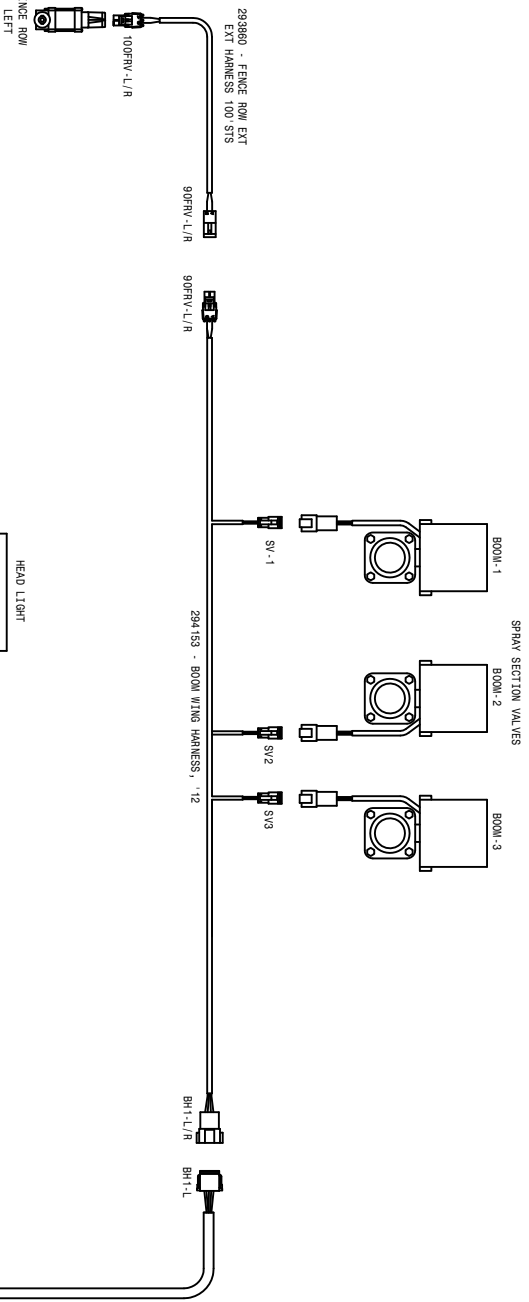

294017 - MAIN CAB ENTRY HARNESS, STS '10
SHEET 5 OF 5

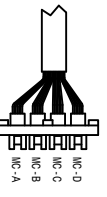

SHEET 3 OF 5
SHEET 2 OF 5
SHEET 2 OF 5

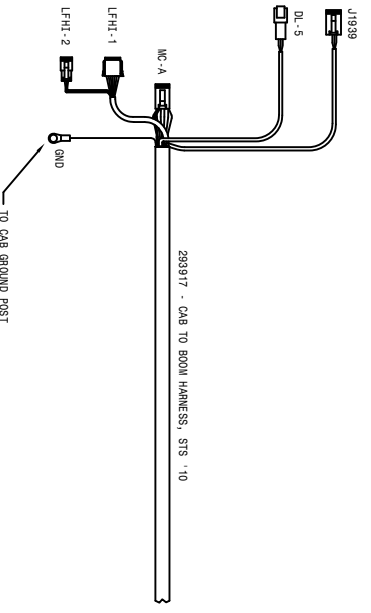

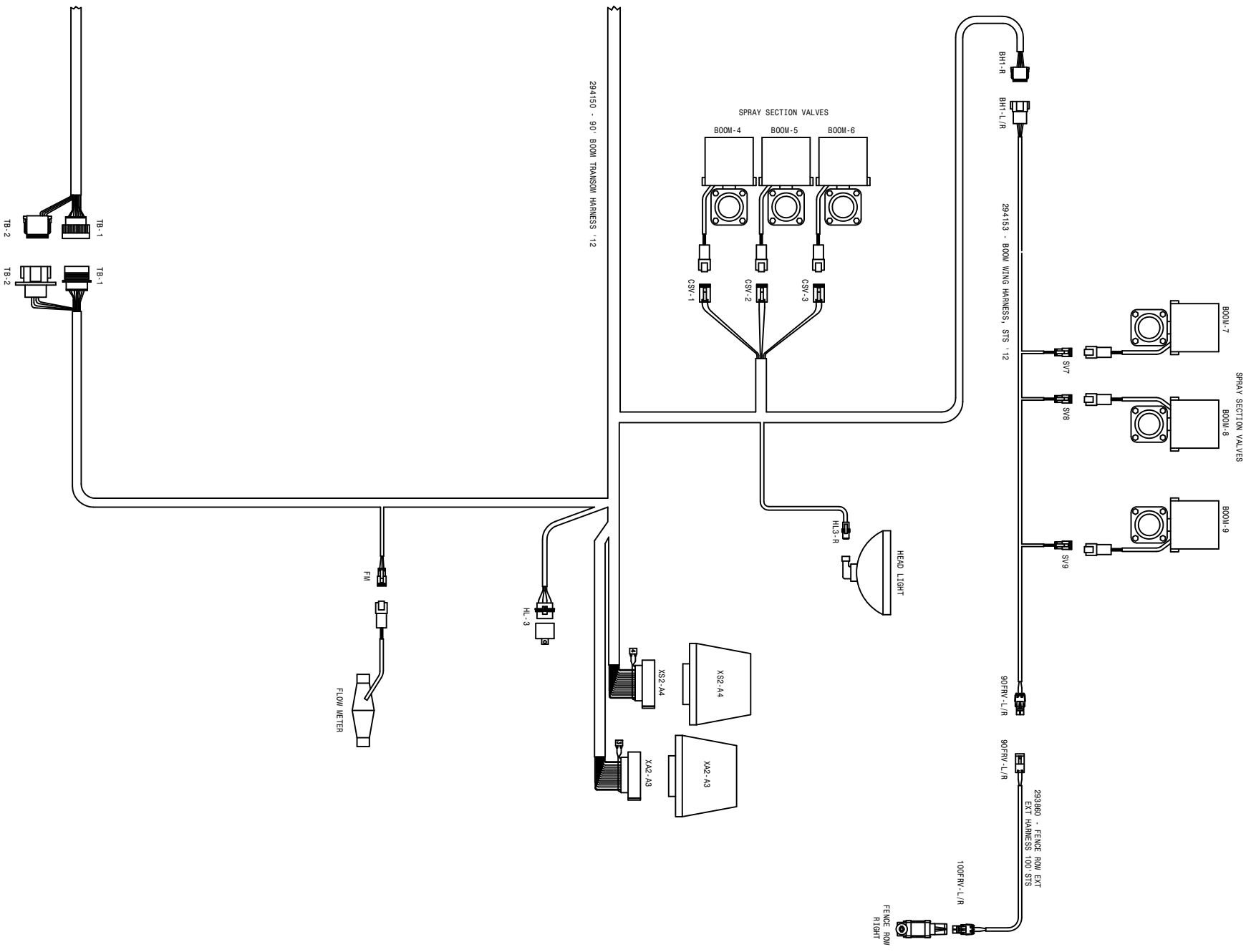

06-07-11 DATE
STS 10/12 WIRING DIAGRAM '12
 SHEET 1 OF 5
 REVISION DATE: 4992240

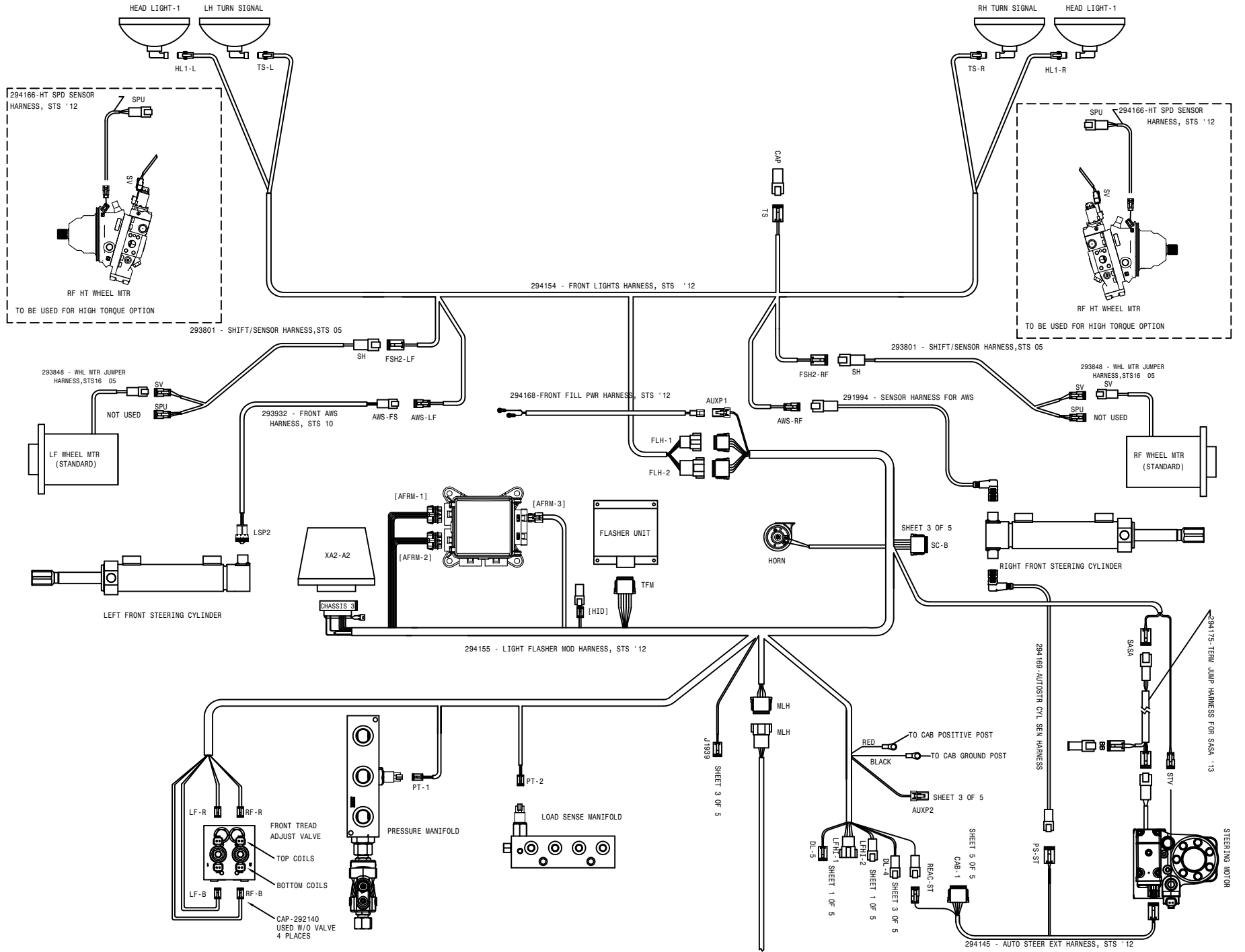

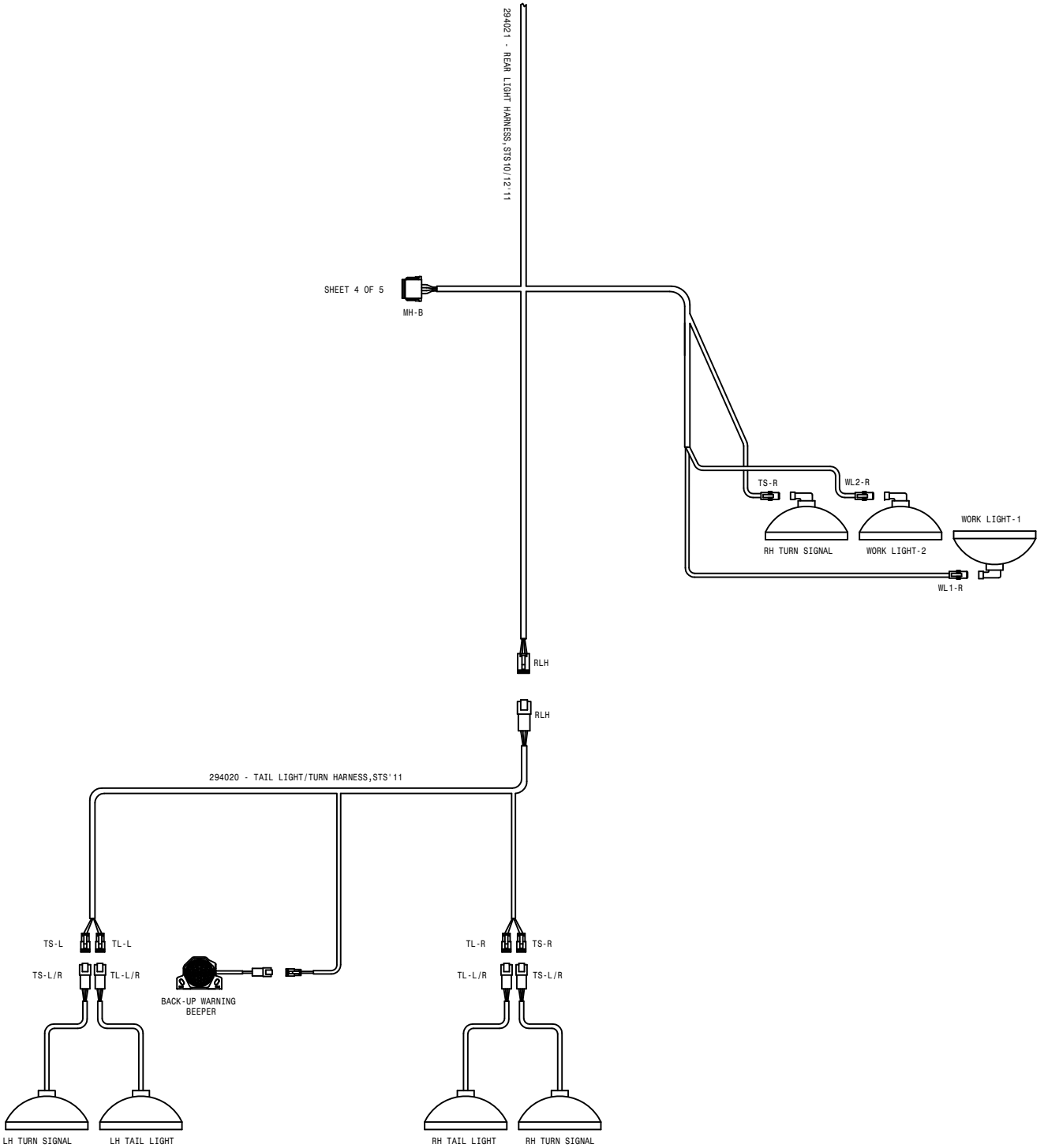

STS10/12 WIRING DIAGRAM 12
 SHEET 2 OF 5
 REVISION DATE: 22/11/12
 499240
 06-07-11 001

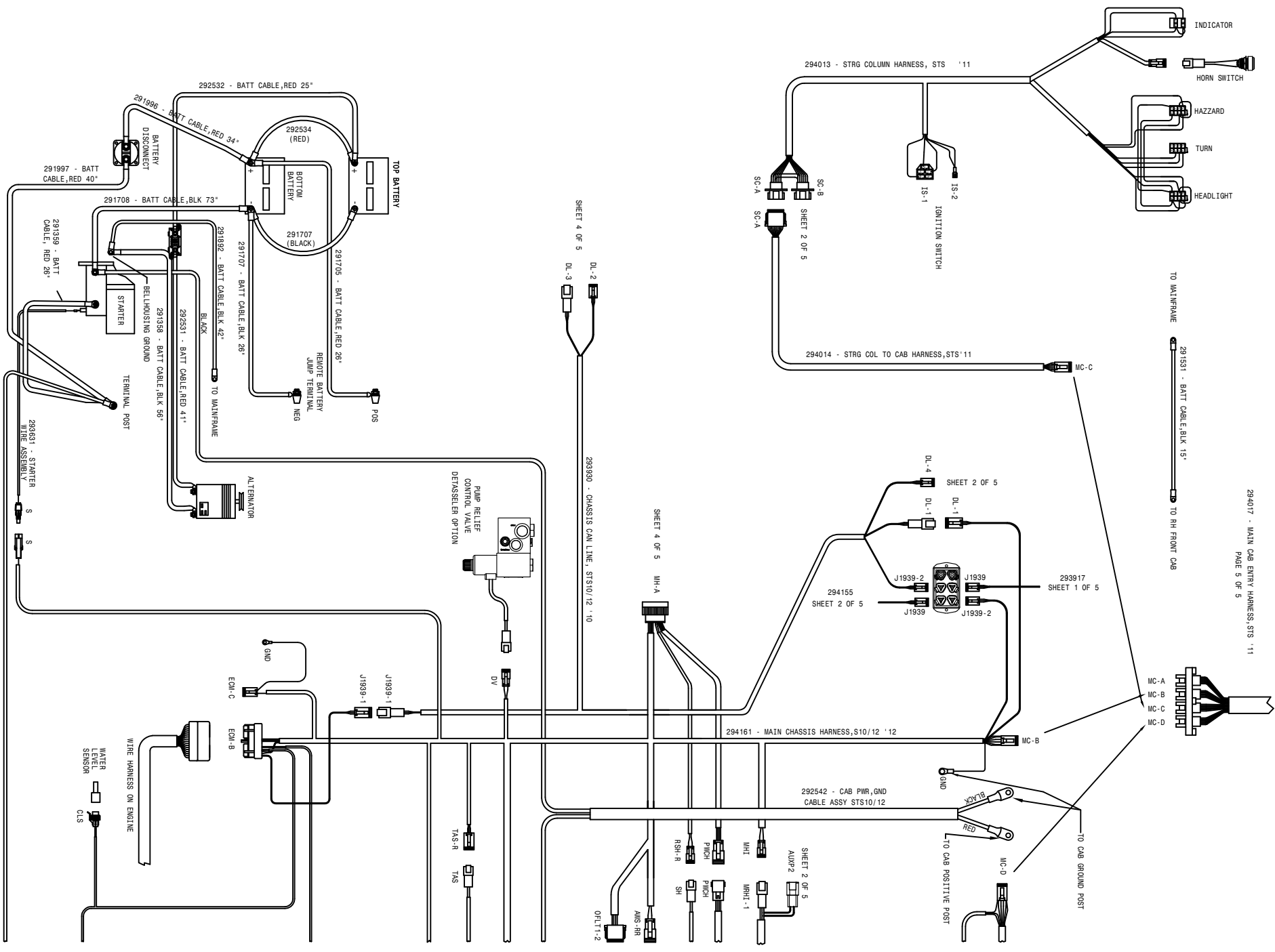

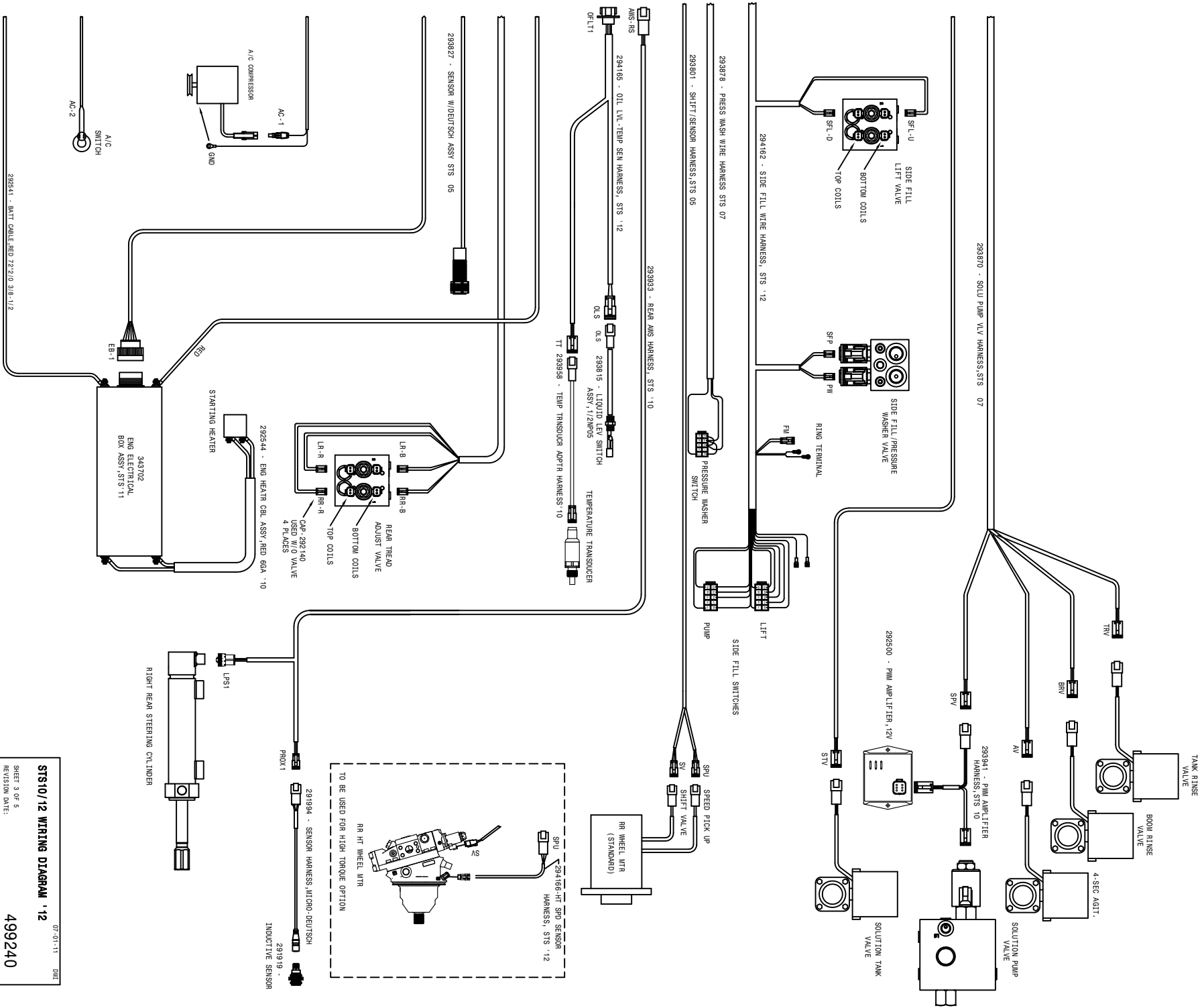

ST310/12 WIRING DIAGRAM 12
 SHEET 3 OF 5
 REVISION DATE:
 499240

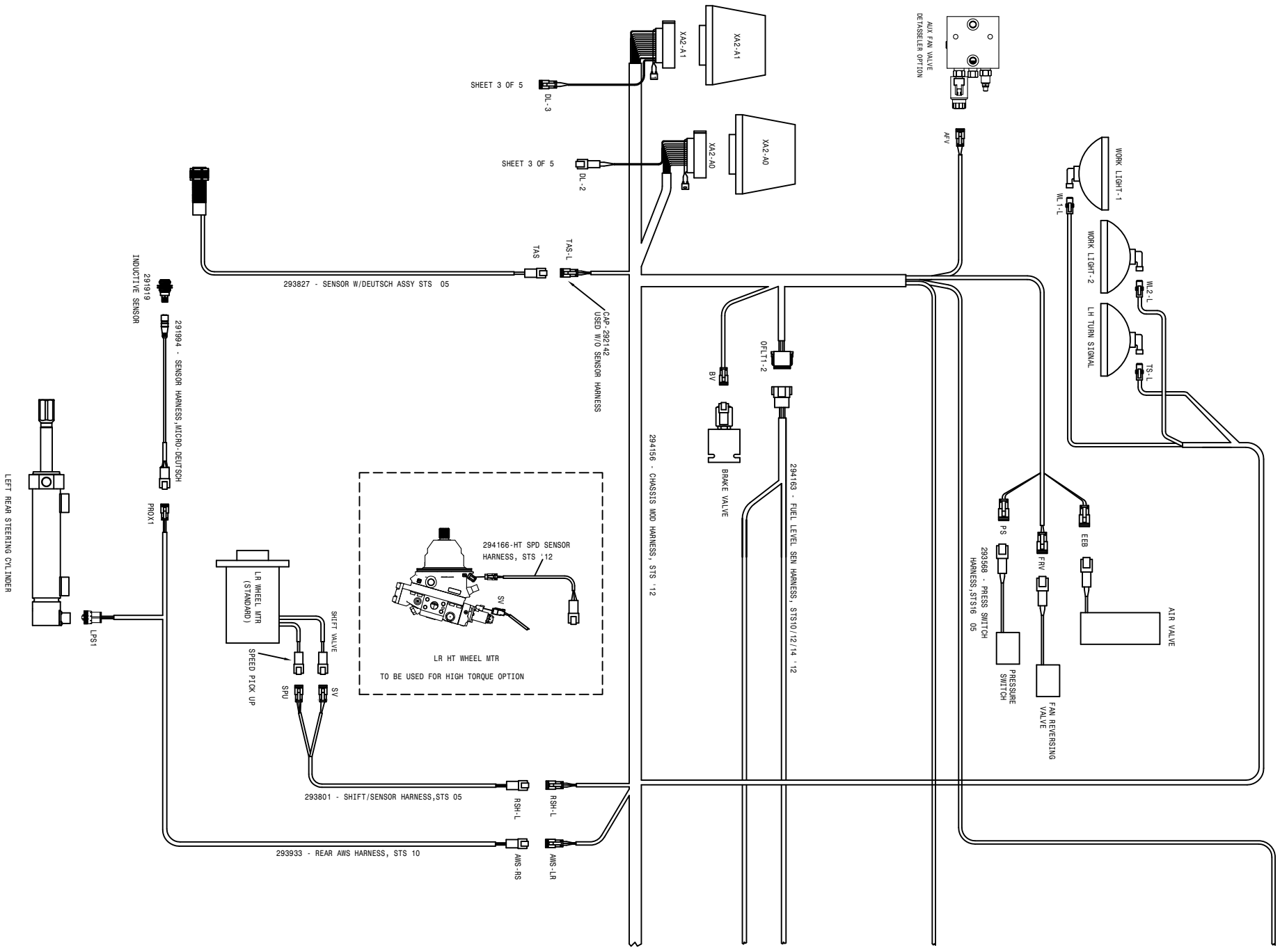

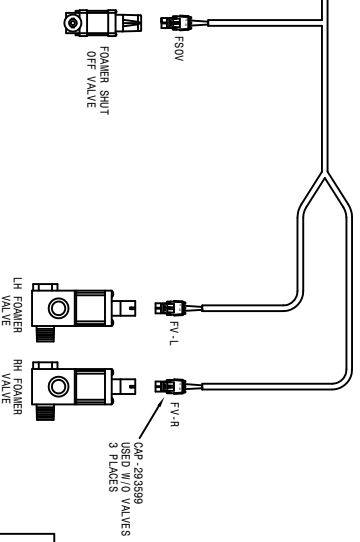
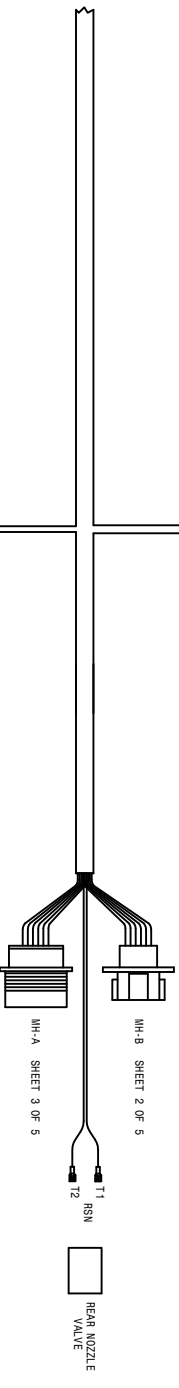
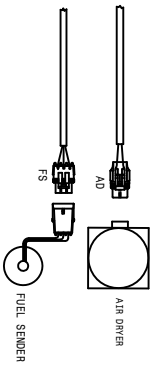
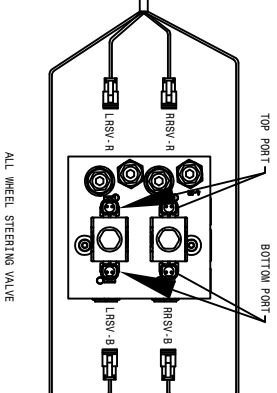
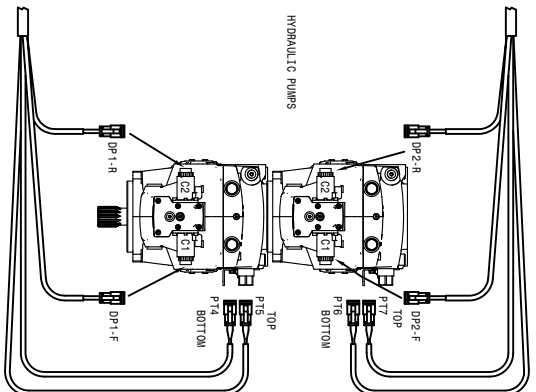

06-07-11 DWT
STS 10/12 WIRING DIAGRAM 12
 SHEET 4 OF 5
 REVISION DATE: 499240

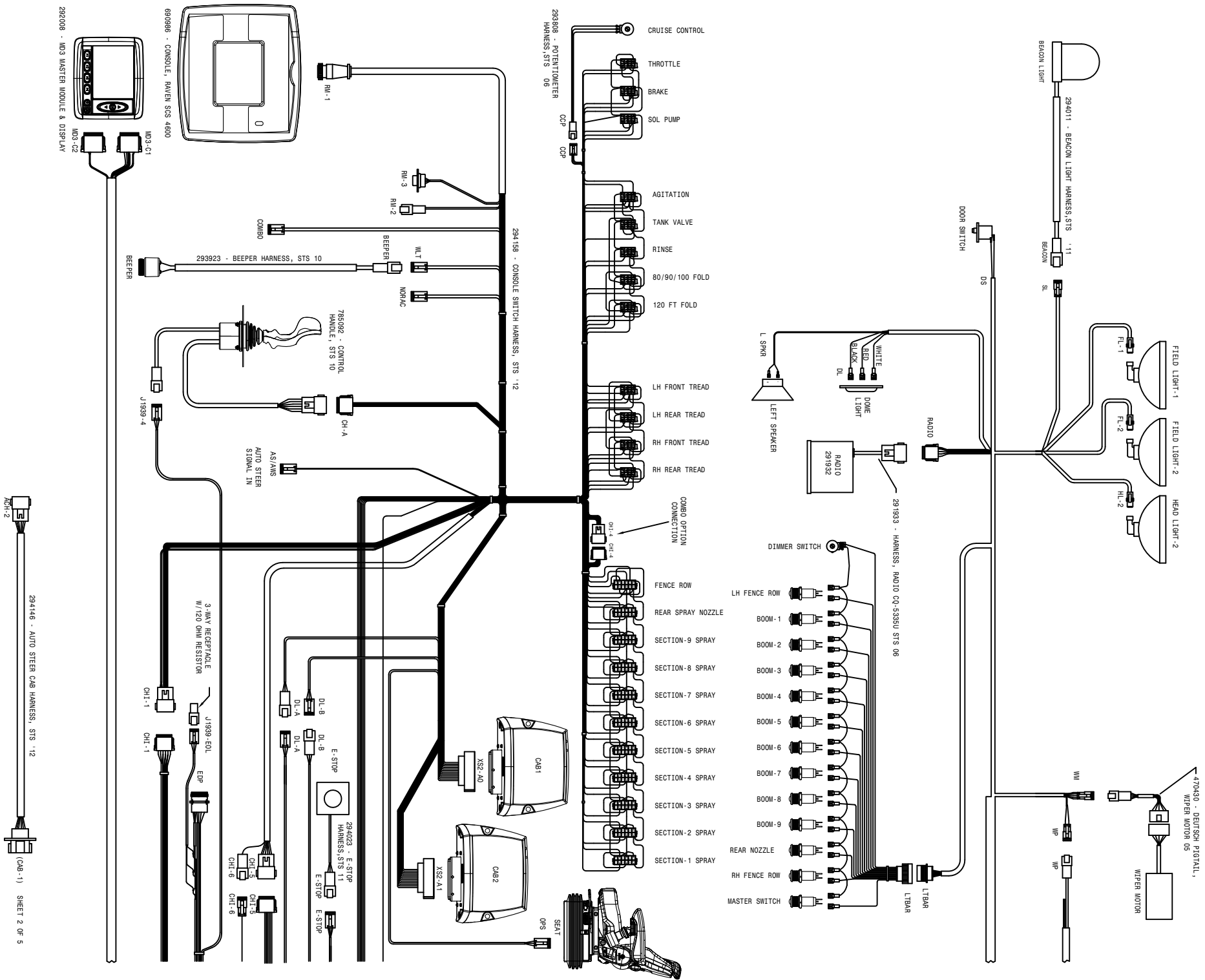

294146 - AUTO STEER CAB HARNESS, STS 12 (CAB-1) SHEET 2 OF 5

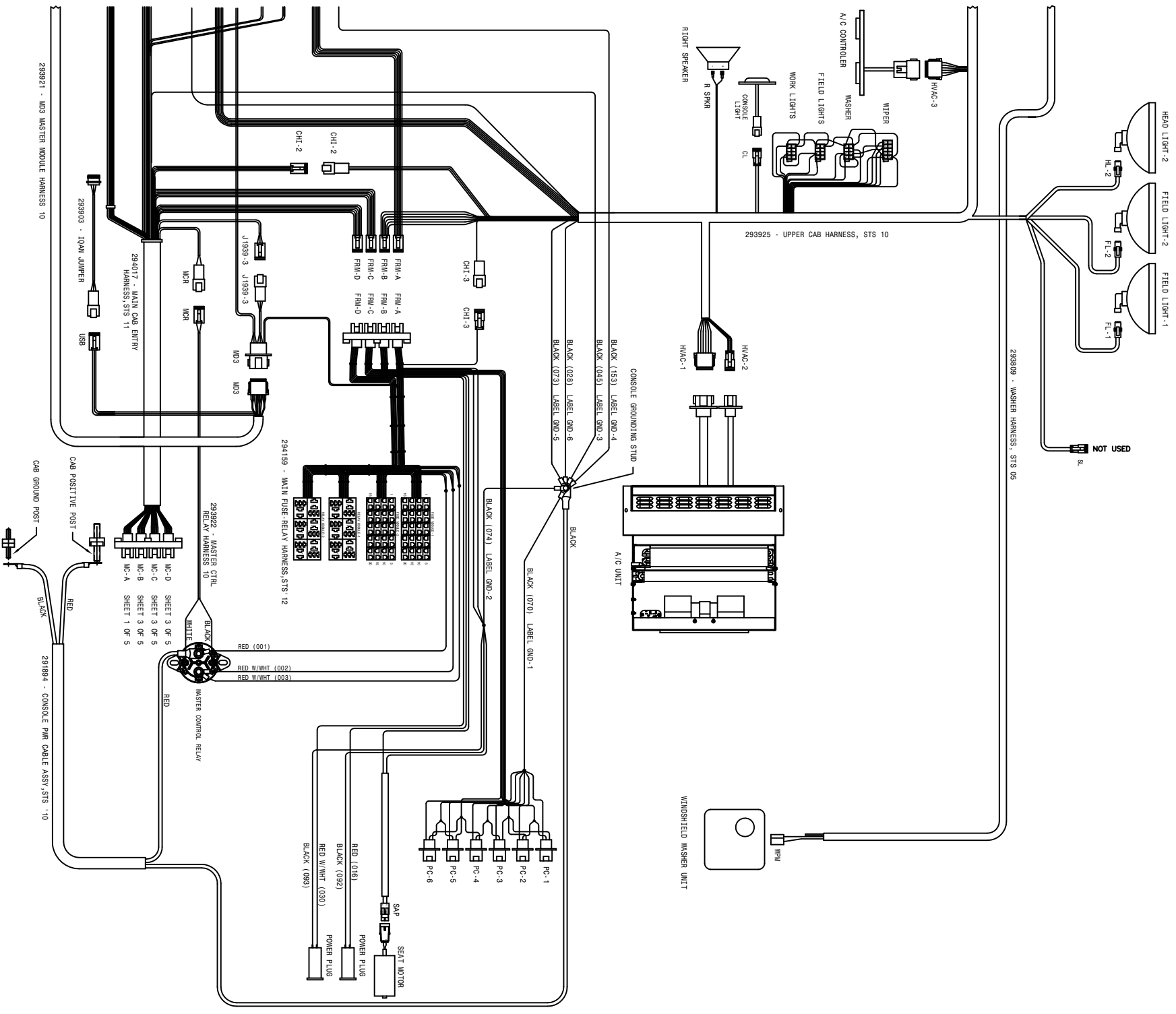

06-07-11 QUT
STS 10/12 WIRING DIAGRAM - 12
 SHEET 5 OF 5
 REVISION DATE: 10-24-11
4992240

ABBREVIATIONS

A/C - AIR CONDITIONER	MT - MOUNT
ADPTR - ADAPTER	MTR - MOTOR
AGI - AGITATOR	P/N - PART NUMBER
ALT - ALTERNATOR	PLT - PLATE
ASSY - ASSEMBLY	QTY - QUANTITY
BRKT - BRACKET	RED - REDUCER
DET - DETAIL	REF - REFERENCE
DISPL - DISPLACEMENT	REST - RESTRICTOR
EL - ELBOW	REQ - REQUIRED
EXT - EXTENSION	SHFT - SHAFT
FLO - FLOW	SOL - SOLUTION
FNPT - FEMALE NATIONAL PIPE THREAD	STRG - STEERING
FOR - FEMALE O-RING	ST - STREET
FRT - FRONT	SV - STANDARD VOLUME
HV - HI-VOLUME	SWIV - SWIVEL
HYD - HYDRAULIC	UNC - UNIFIED NATIONAL COURSE
HYDRO - HYDROSTATIC	UNF - UNIFIED NATIONAL FINE
LG - LONG	V - VOLT
LWR - LOWER	W/ - WITH
MJIC - MALE J.I.C.	WHL - WHEEL
MOR - MALE O-RING	WLD - WELDMENT

INDEX

-A-

ABBREVIATIONS.....132
 AIR DRYER.....46
 AIR CLEANER.....10
 FILTER.....10
 AIR COMPRESSOR GOVERNOR.....10
 AIR CONDITIONER
 BINARY SWITCH.....8
 COMPRESSOR.....6
 CONDENSOR COIL.....9
 CONTROLLER.....52
 HOSE.....8,9
 RECEIVER/DRYER.....8
 TUBE.....39
 AIR COOLER, CHARGE.....9
 AIR PRESSURE GAUGE.....86
 AIR REGULATOR, FOAMER.....86
 AIRRIDE SPRING.....16,19,22,25
 AIR VALVE.....16,18,22,25
 ALTERNATOR.....5
 ARM, STEERING.....16,19,22,25
 ALL WHEEL STEER,
 LEG.....16,19,22,25
 MODULE.....99
 VALVE.....98

-B-

BACK-UP BEEPER.....9
 BATTERY.....14
 CABLE.....4,5,10,14
 BOX PANEL.....9
 BEARING,
 BRONZE LEG.....16,19,22,25,28
 ORKOT.....16,19,22,25
 BELT,
 AIR CONDITIONER.....6
 DRIVE.....5
 BLOCK, TERMINAL.....64
 BOX,
 ELECTRICAL.....68
 PRESSURE WASHER.....88
 SIDE FILL.....91
 BRACE, RADIATOR.....8
 BUMPER, REAR.....70

-C-

CAB.....50,51
 ROOF.....50,51
 CABLE BATTERY.....4,5,10,14

CAP, FUEL.....12

RADIATOR.....9
 CHARGE AIR COOLER.....9
 CHEMICAL INDUCTOR.....91
 COMPRESSOR, A/C.....6
 CONDENSOR COIL, A/C.....9
 CONSOLE.....62
 COOLER, OIL.....9
 CYLINDER,
 GAS.....70
 LADDER.....43
 SIDE FILL.....92
 STEERING.....16,19
 TREAD ADJUST.....28,29

-D-

DECALS.....100,101
 DIAGRAMS,
 AIR LINE.....99
 WIRING.....122
 DOOR.....58,59
 LATCH.....59,70,71
 DRAIN COCK, AIR.....47,48
 DRIVE
 BELT.....5
 DISK.....4

-E-

ELECTRICAL BOX.....67
 ENGINE.....68
 ENGINE.....4,5
 HOOD.....70,71
 SKID.....8

-F-

FAN.....5
 SPACER.....5
 FILTER,
 AIR CLEANER.....10
 CAB.....50
 FUEL.....4
 HYDRAULIC.....13
 MINDER.....86
 OIL.....5,13
 FLASHER.....66,83,84
 FLOW METER.....96,97

FOAMER
 AIR REGULATOR..... 86
 TANK..... 85
 THREE-WAY VALVE..... 85
 VALVE..... 85
 FRESH WATER..... 86
 FRONT FILL..... 93
 FUEL,
 CAP..... 12
 SENDER..... 12
 TANK..... 12

-G-

GLASS..... 50, 51

-H-

HANDBRATL..... 44
 HEADLINER..... 52
 HEATER TUBE..... 35
 HOOD, ENGINE..... 70, 71
 HOSE, A/C..... 8
 HOISING,
 SOLUTION..... 75, 76, 77, 78
 HUB, TORQUE..... 17, 20, 23, 26
 HYDRAULIC,
 FILTER..... 13
 LEVER..... 63
 MANIFOLD..... 36, 37, 38, 39
 SCHEMATIC..... 102
 TANK..... 13
 TUBE..... 34, 35
 VALVE..... 40, 42
 HYDROSTATIC PUMP..... 7

-I-

IGNITION SWITCH..... 57

-L-

LADDER..... 43
 CYLINDER..... 43
 PIVOT ARM..... 43
 LEG..... 16, 19, 22, 25
 ALL WHEEL STEER... 16, 18, 22, 25
 LEVER,
 HYDROSTATIC..... 63
 QUICK ATTACH..... 82
 LIGHT..... 50, 51
 LINE STRAINER..... 72
 LIQUID LEVEL SWITCH..... 13

-M-

MDM DISPLAY..... 52

MIRROR..... 50, 51
 MONITOR, SPRAYER..... 60
 MOTOR,
 STEERING..... 56
 WHEEL..... 17, 20, 23, 26
 MOUNT, RUBBER..... 8, 51
 MUFFLER..... 11

-N-

NOZZLE,
 MOUNT TUBE..... 79
 REAR WHEEL..... 79

-O-

OIL COOLER..... 9
 OIL FILTER..... 5, 13

-P-

PANEL,
 BATTERY BOX..... 9
 SWITCH..... 61
 PLATFORM, SERVICE..... 46
 PRESSURE TRANSDUCER..... 36, 39
 PRESSURE WASHER..... 89
 BOX..... 88
 VALVE..... 88
 PUMP,
 HYDRAULIC..... 4
 HYDROSTATIC..... 7
 SIDE FILL..... 92
 SOLUTION..... 80

-R-

RADIATOR..... 9
 BRACE..... 8
 CAP..... 9
 HOSE..... 5
 RADIO..... 52
 REAR WHEEL NOZZLE..... 79
 RINSE TANK..... 72
 RUBBER
 MOUNT..... 8, 9, 51
 SPRING..... 16, 19, 22, 25

-S-

SCHEMATIC, HYDRAULIC..... 102
 SEAT..... 53, 54
 SENDER, FUEL..... 12
 SENDER, WATER LEVEL..... 9
 SERVICE PLATFORM..... 32
 SHEET METAL..... 71

SHIELD, WHEEL MOTOR.....	17, 20, 23, 26
SIDFILL.....	92
BOX.....	91
CYLINDER.....	92
SIGHT GAUGE, OIL.....	13
SKID, ENGINE.....	.8
SMV SIGN.....	.70
SOLUTION	
HOSING.....	.75, 76, 77, 78
PUMP.....	.80
TANK.....	.73
VALVE.....	.40
SPACER, FAN.....	.5
SPEAKER.....	.52
SPRAY MONITOR.....	.60
SPRING,	
AIRRIDE.....	16, 19, 22, 25
SOLUTION TANK.....	.73
STARTER.....	.5
STEERING,	
ARM.....	16, 19, 22, 25
COLUMN.....	.57
CYLINDER.....	16, 19
MOTOR.....	.56
STRAINER, LINE.....	.80
SWITCH,	
A/C BINARY.....	.8
IGNITION.....	.57
LIQUID LEVEL.....	.13
PANEL.....	.61

-T-

TAILLIGHT.....	.70
TANK	
AIR.....	.47, 48
FOAMER.....	.85
FRESHWATER.....	.86
FUEL.....	.12
HYDRAULIC.....	.13
RINSE.....	.72
SOLUTION.....	.73
TERMINAL BLOCK.....	.64
TIRE.....	.15
TORQUE HUB.....	17, 20, 23, 26
TREAD ADJUST	
CYLINDER.....	.28, 29
VALVE.....	.32, 33
TUBE,	
A/C.....	.25
HEATER.....	.25
HYDRAULIC.....	.24, 25

-V-

VALVE,	
AIR.....	16, 19, 22, 25
ALL WHEEL STEER.....	.98
BALL.....	.65, 73
ELECTRIC BALL.....	.72, 76
FOAMER.....	.85
HYDRAULIC.....	.40, 42
PRESSURE WASHER.....	.89
SIDE FILL.....	.92
SOLUTION.....	.40
TREAD ADJUST.....	.32, 33

-W-

WASHER, PRESSURE.....	.89
WATER LEVEL SENSOR.....	9
WHEELMOTOR.....	17, 20, 23, 26
SHIELD.....	17, 20, 23, 26
WIRING DIAGRAM.....	122

Notes: