

PARTS MANUAL
FOR
HAGIE MODEL STS 10 HI-TRACTOR

HAGIE MANUFACTURING COMPANY

BOX 273 CLARION, IOWA 50525

(515) 532-2861

COVERS MACHINE SERIAL NUMBERS: U1610330001 thru U1610330100

12-02 493272
02-08

SPRAYER IDENTIFICATION

Each Hagie sprayer is identified by means of a frame serial number. This serial number denotes the model, the year in which it was built, and the number of the sprayer. As for further identification, the engine has a serial number and the planetary hubs have identification plates that describe the type of mount and gear ratio. To insure prompt, efficient service when ordering parts or requesting service repairs from Hagie Manufacturing Company, record the serial and identification numbers in the space provided below.

NOTE: Reference to left hand and right hand used throughout this manual refers to the position when seated in the operator's seat facing forward.

SPRAYER SERIAL NUMBER

ENGINE SERIAL NUMBER

PLANETARY HUB IDENTIFICATION NUMBERS

TABLE OF CONTENTS

ENGINE ASSEMBLY 4-11

RADIATOR AND OIL COOLER ASSEMBLY. 12

FUEL AND OIL TANK ASSEMBLY. 13-14

BATTERY. 15

AIR TANK ASSEMBLY 16-17

FILTER AND BRAKE VALVE ASSEMBLY 18-19

LEG ASSEMBLY 20-27

STEERING CYLINDER. 28

TIRE ASSEMBLY 29

HYDRAULIC TUBING 30-31

TREAD ADJUST ASSEMBLY 32-34

ELECTRICAL BOXES 35-38

CAB ASSEMBLY. 39-42

SWITCH PANEL ASSEMBLY 43-44

ATI CONTROLER BOX ASSEMBLY 45

MIRROR BRACKETS 46-47

SHEET METAL 48-49

SERVICE PLATFORM. 50

LADDER ASSEMBLY. 51

SOLUTION TANK 52-56

SOLUTION PUMP AND ELECTRIC VALVES 57-71

SOLUTION HOISING 72-79

REAR WHEEL NOZZLE 80

FOAMER TANK ASSEMBLY. 81-86

TRANSOM, BOOM, AND LIFT COMPONENTS. 87-102

PRESSURE WASHER OPTION. 103-106

SIDE FILL/CHEMICAL INDUCTOR OPTION. 107-113

FRONT FILL OPTION. 114

RADAR OPTION. 115

FENDER OPTION 116-117

FLOW MAX 110 MONITOR 118-119

DECALS. 120-121

HYDRAULIC SCHEMATIC 122-129

ELECTRICAL SCHEMATIC 130-144

ABBREVIATIONS 145

INDEX. 146

PARTS ORDER FORM. 149

ENGINE ASSEMBLY

DET.	QTY	PART NO.	DESCRIPTION
1	1	316360	CUMM ENG, QSB5.9C, 275@2500CMPSR
2	1	470118	1/4UNC X 3/4 FLANGE HEX BOLT
3	1	470121	1/4UNC HEX FLANGE LOCK NUT
4	12	473798	10MM LOCK WASHER
5	12	473818	10MM-1.50 X 40MM HEX BOLT
6	2	473767	6MM-1.00 HEX NUT
7	2	473768	6MM LOCK WASHER
8	2	291701	BATT CABLE, RED 40" 6GA 1/4-1/4
9	1	291704	BATT CABLE, BLK 172" 6GA 3/8-3/8
10	2	520080	HOSE CLAMP NO 10 STAINLESS
11	2	520120	HOSE CLAMP NO 4 STAINLESS
12	1	611302	08P919-10FJX-10FJX-69 H/A
13	1	601467	HOSE, 5/8 X 69 HEATER
14	1	520121	CUSH HOSE CLAMP 1IN X 3/4W
15	1	711036	1/8MNPT-1/4 NYL TUBE FTG
16	1	800502	PUMP DRIVE, DIRECT SAE#3/C 23T
17	8	900128	3/8UNC X 3/4 HEX BOLT
18	8	920502	3/8 LOCK WASHER
19	1	601474	HOSE, 1/4 X 26 AIR
20	1	800503	DRIVE DISK ASSY, 11.5" 23T SPL
21	1	316373	FUEL/WATER SEPERATOR (316360)
22	1	316378	FUEL TRANSFER PUMP FOR 316360
23	1	316501	COMPRESSOR HOSE GUARD STS
24	2	470154	CABLE TIE, 11.75" BLK PLASTIC

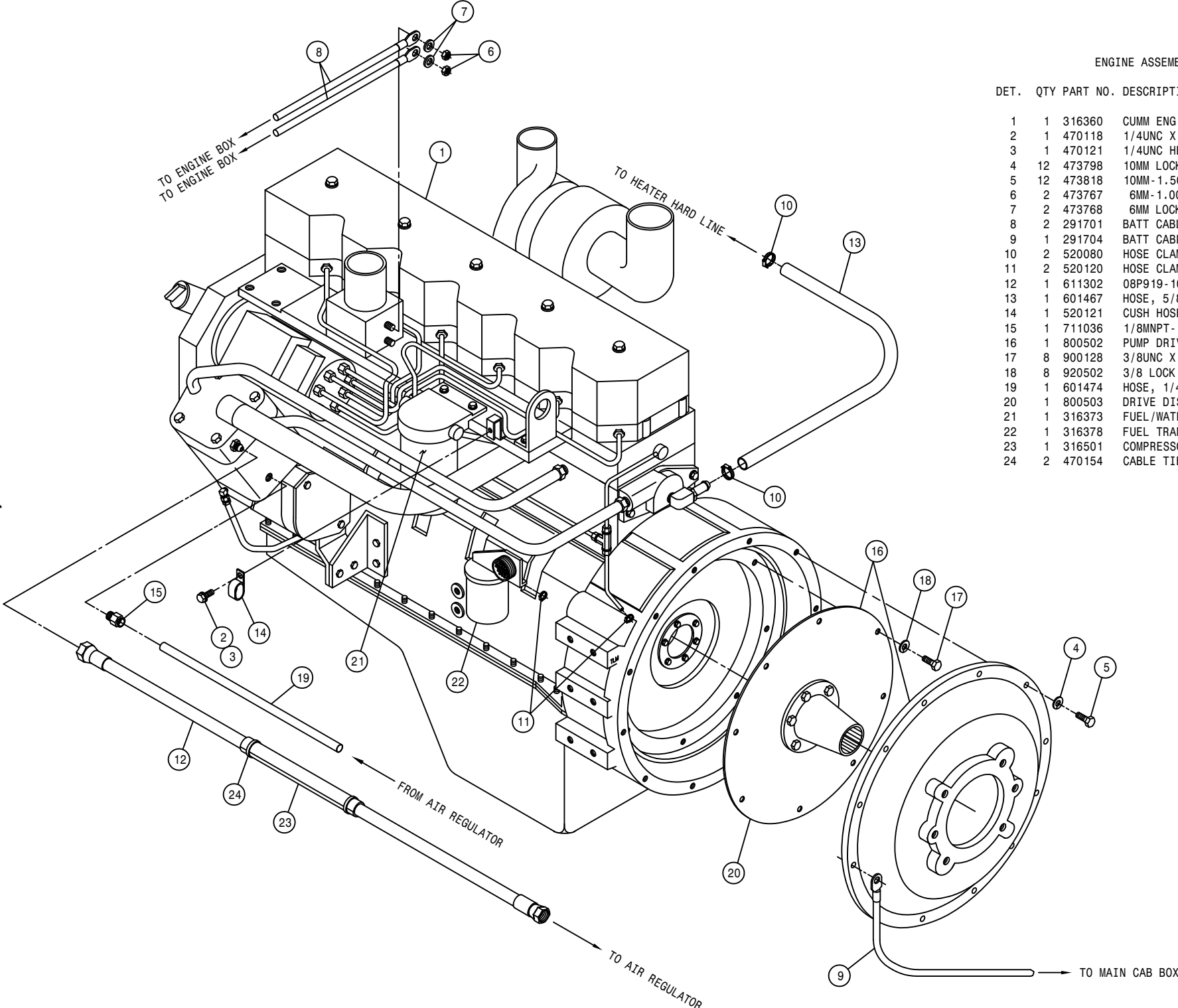

4

ENGINE ASSEMBLY

DET. QTY PART NO. DESCRIPTION

DET.	QTY	PART NO.	DESCRIPTION
1	1	314832	RADIATOR HOSE 1.75 X 19
2	1	314987	LWR RADIATOR HOSE STS-12
3	1	316360	CUMM ENG, QSB5.9C, 275@2500CMPSR
4	1	316362	FAN SPACER, QSB5.9C STS12 00
5	1	316524	FAN, CUMM QSB5.9C, STS12 2002
6	1	316367	DELCO ALTERNATOR, 130 AMP 22SI
7	1	316370	ALT PULLEY, 2.76 OD, 8-GROOVE
8	2	473766	10MM LOCK WASHER, INT TOOTH
9	4	473769	10MM-1.50 X 100MM FLG HEX BOLT
10	1	473770	5MM-.80 HEX NUT
11	1	473796	10MM-1.50 X 16MM HEX BOLT
12	4	473798	10MM LOCK WASHER
13	4	473799	10MM FLAT WASHER
14	1	291700	BATT CABLE, RED 31" 6GA 1/4-3/8
15	1	291706	BATT CABLE, RED 70" 2/0 3/8-3/8
16	1	291766	BATT CABLE, RED 48" 2/0 3/8-3/8
17	1	291708	BATT CABLE, BLK 73" 2/0 3/8-3/8
18	1	291763	BATT CABLE, BLK 33" 6GA. 281-.406
19	2	520067	HOSE CLAMP NO 28 STAINLESS
20	1	520069	HOSE CLAMP NO 6 STAINLESS
21	3	520080	HOSE CLAMP NO 10 STAINLESS
22	2	520099	HOSE CLAMP NO 40 STAINLESS
23	1	601468	HOSE, 5/8 X 91 HEATER
24	2	616137	12-421HT-12FJX-12FJX-68 H/A
25	1	316471	STARTER SOLENOID NUT ASSY
26	1	316372	LUBE FILTER (CUMM ENG 316360)
27	2	618302	1 1/16MJIC-90-1 5/16MOR LBO
28	1	316525	DRIVE BELT, QSB5.9C 316360 02
29	1	601529	HOSE, 3/4 X 34 CLEAR VINYL
30	2	618189	1 1/16MJIC-7/8MOR ADPTR
31	2	618191	1 1/16MJ-90-1 1/16FJ SWIV LBO
32	2	473827	8MM-1.25 X 20MM HEX BOLT
33	2	473804	8MM LOCK WASHER

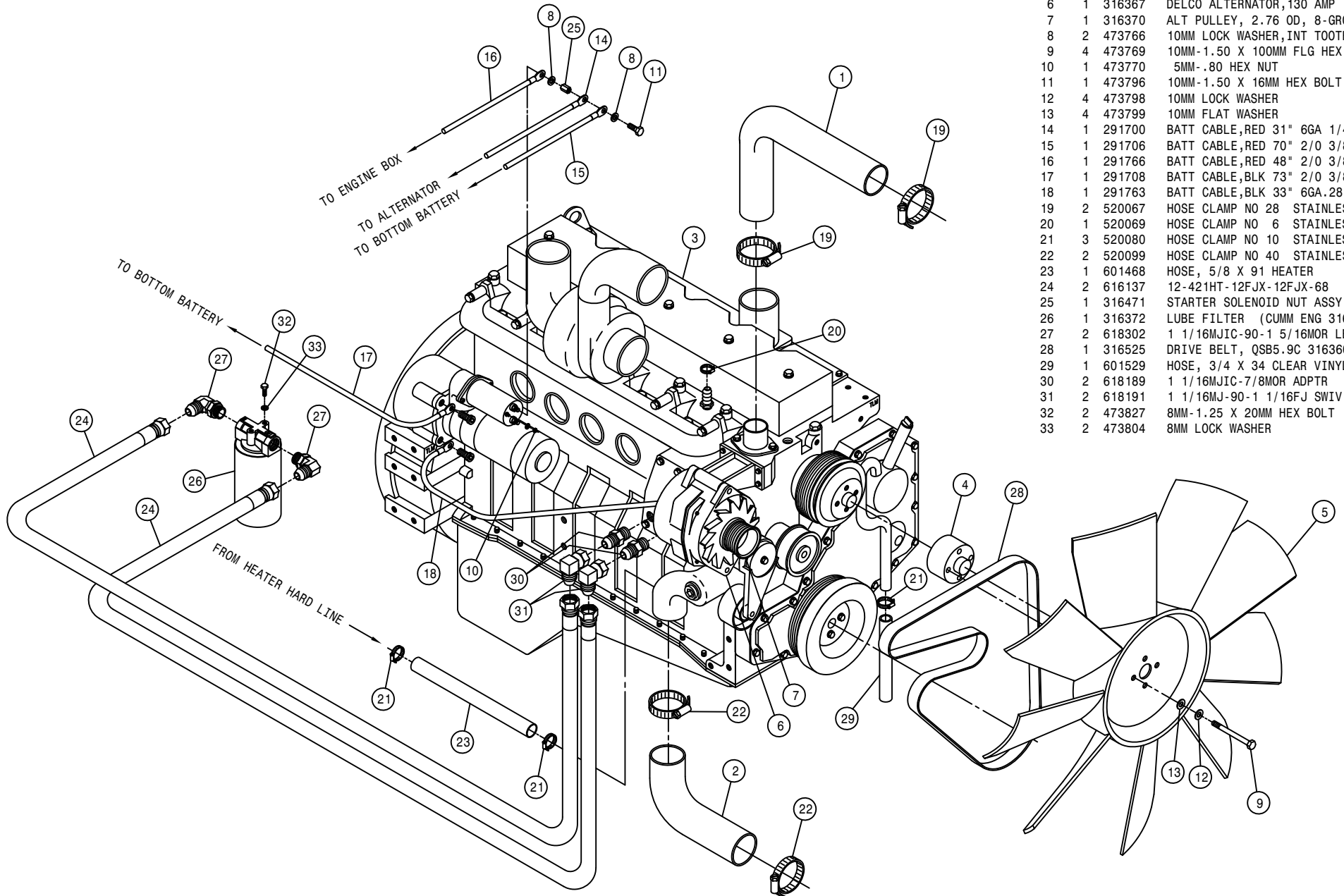

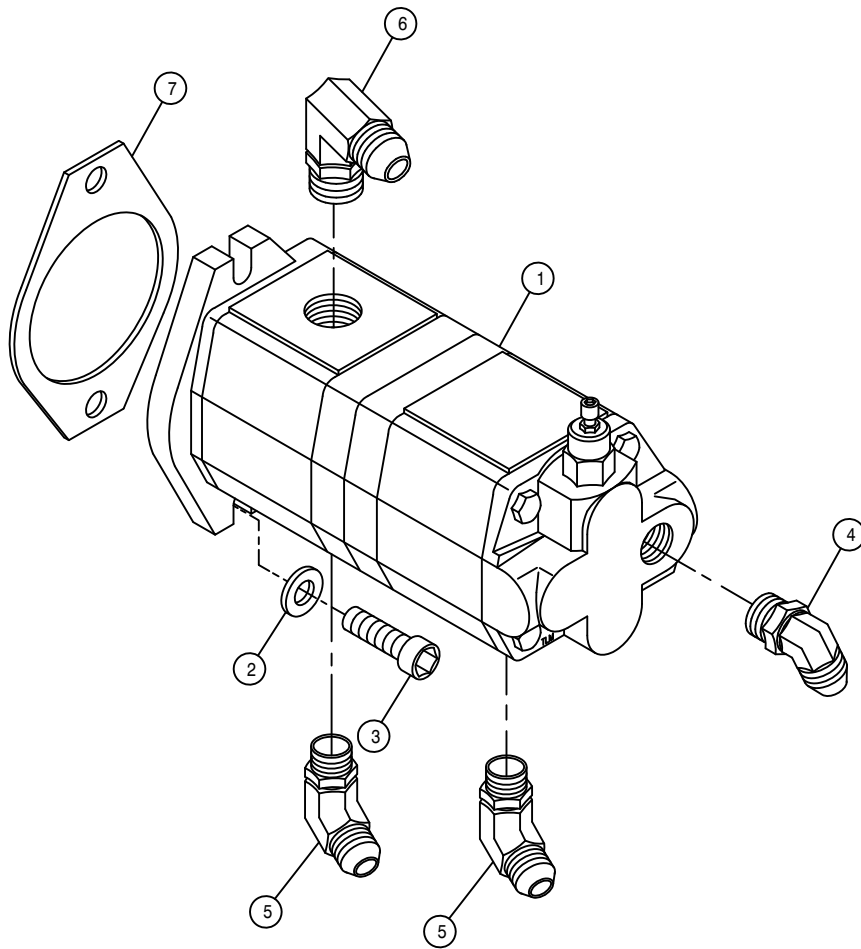

STEERING AND TREAD ADJUST PUMP ASSEMBLY

DET. QTY PART NO. DESCRIPTION

DET.	QTY	PART NO.	DESCRIPTION
1	1	606990	TANDEM PUMP, .66CI/.51CI
2	2	473799	10MM FLAT WASHER
3	2	473844	10MM-1.50 X 30 SOC HD CAP SCR
4	1	618315	3/4MJIC-45-3/4MOR LBO
5	2	618183	3/4MJIC-90-7/8MOR LBO
6	1	618248	1 1/16MJIC-90-1 1/16MOR LBO
7	1	316371	GASKET, AUX DRIVE CUMM 154916

A/C COMPRESSOR PUMP ASSEMBLY

DET. QTY PART NO. DESCRIPTION

1	1	147049	BELT, 9425 GATES
2	1	316522	A/C MTG BRKT WLD, STS 2002
3	3	473844	10MM-1.50 X 30 SOC HD CAP SCR
4	3	473798	10MM LOCK WASHER
5	2	483043	3/8 REGULAR FLAT WASHER
6	1	657450	A/C COMP SR,90D PORT TM15/12
7	4	900131	3/8UNC X 1 1/2 HEX BOLT
8	4	914004	3/8UNC HEX STOVER NUT
9	1	657446	A/C HOSE,08-08F90-08F90SV-65"
10	1	657447	A/C HOSE, 10-10F90-10F90SV-92"

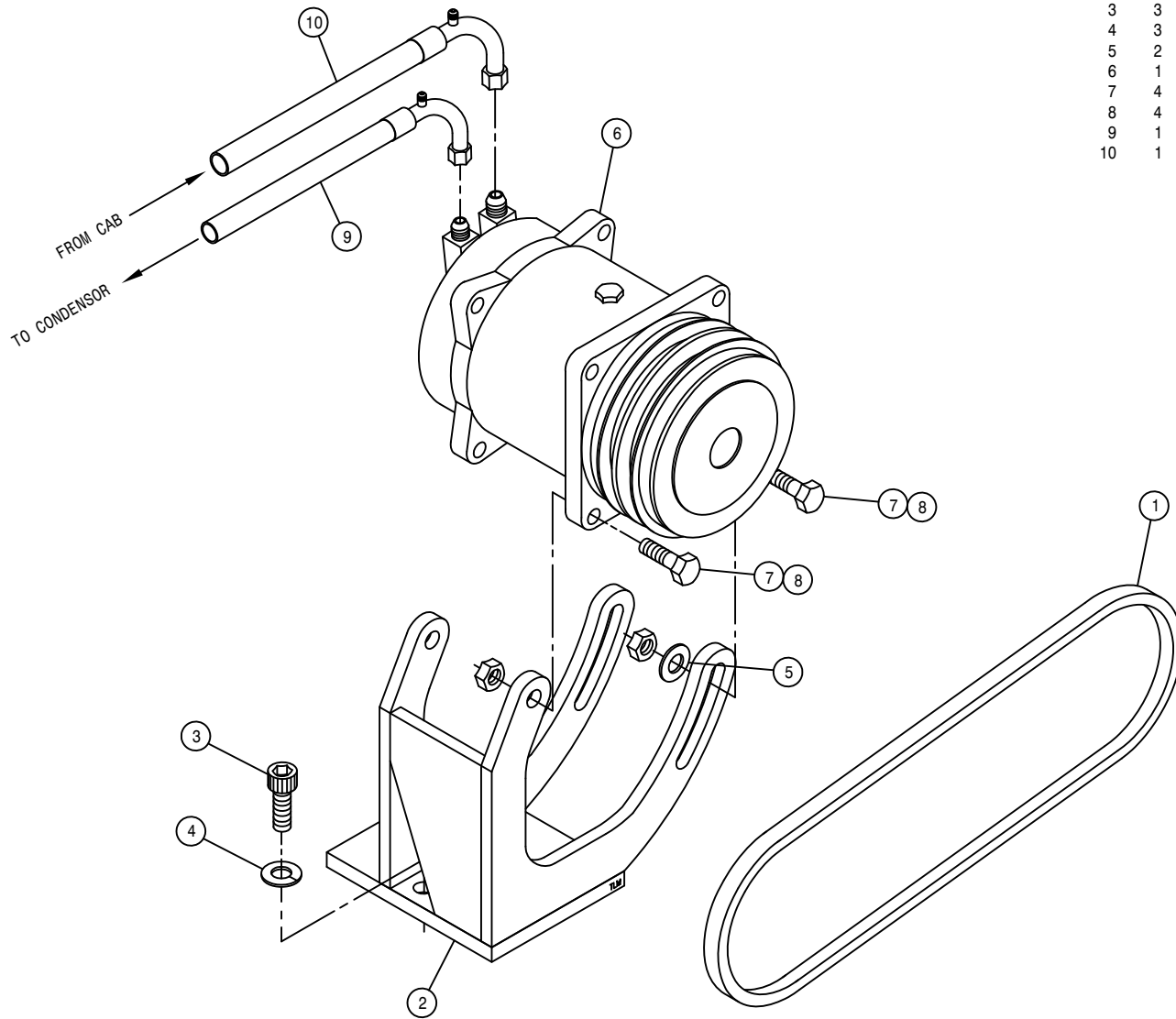

HYDROSTATIC PUMP ASSEMBLY

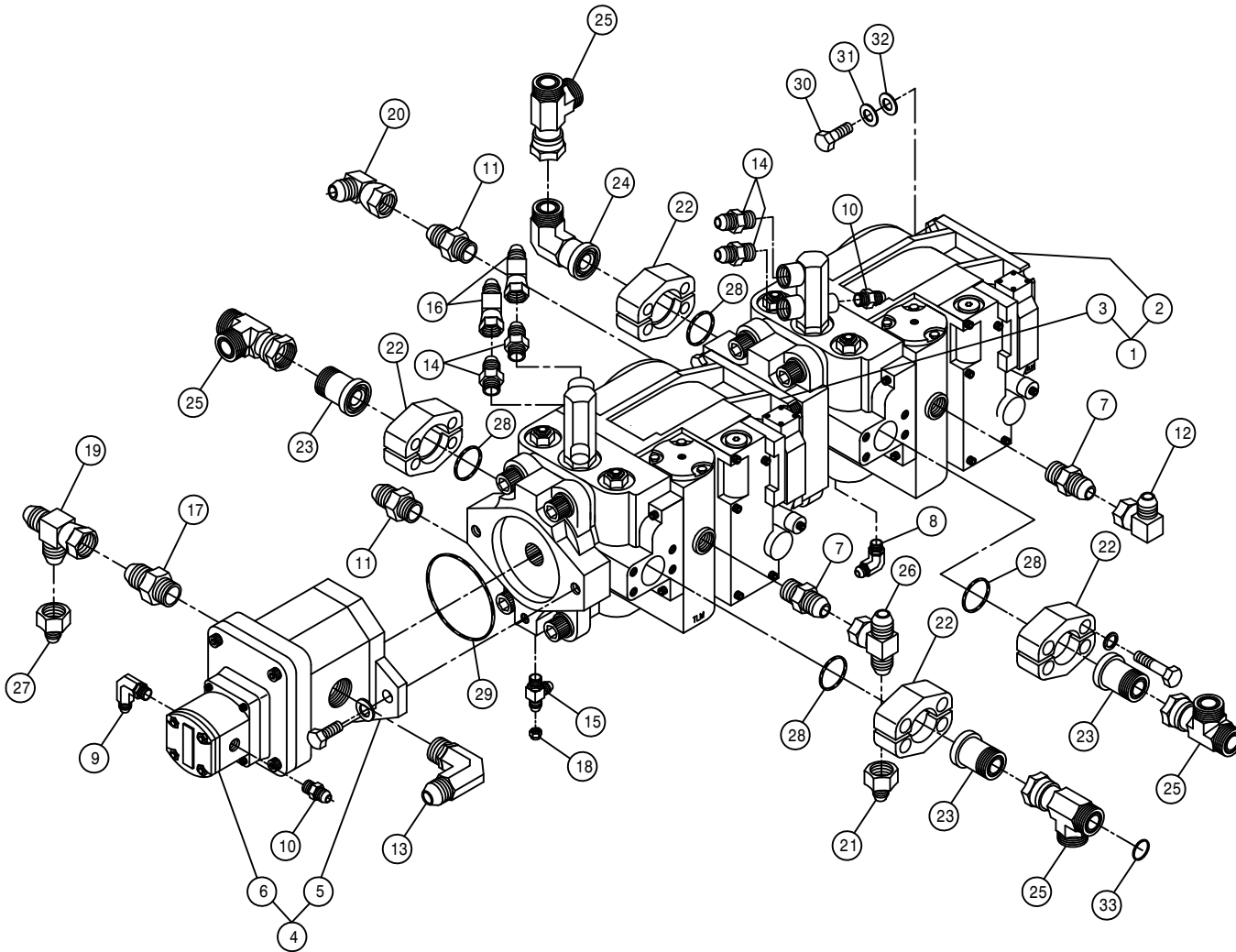

DET. QTY PART NO. DESCRIPTION

1	1	606965	TANDEM PUMP, 606966 & 606969
2	1	606966	SUND 75CC PUMP,C/C-MT
3	1	606969	SUND 75CC PUMP,C/B-MT
4	1	606972	TANDEM PUMP, 606984 & 606987
5	1	606984	SUND GEAR PUMP,2.02CI GRP3
6	1	606987	SUND GEAR PUMP, .128CI GRP3
7	2	611127	1 1/16MJIC-1 1/16MOR ADPTR
8	1	614754	.050 ELBOW ASSY,9/16MOR 90D
9	1	618115	9/16MJIC-90-3/4MOR LBO
10	2	618126	9/16MJIC-9/16MOR ADPTR
11	2	618186	1 5/16MJIC-1 5/16MOR ADPTR
12	1	618191	1 1/16MJ-90-1 1/16FJ SWIV LBO
13	1	618302	1 1/16MJIC-90-1 5/16MOR LBO
14	4	618327	3/4MJIC-7/8MOR ADPTR
15	1	618444	9/16MOR RUN TEE-9/16MJIC
16	2	618451	3/4FJIC SW RUN TEE-3/4MJIC
17	1	618455	1 5/16MJIC-1 5/8MOR ADPTR
18	1	618531	9/16FJIC CAP NUT
19	1	618619	1 5/16FJ SW RUN TEE-1 5/16MJ
20	1	618640	1 5/16MJ-90-1 5/16FJ SWIV LBO
21	1	618641	1 1/16FJIC-1 5/16MJIC ADPTR
22	4	618652	1" SPLIT FLANGE KIT
23	3	618653	1" FLANGE-1 7/16MFOR ADPTR
24	1	618654	1" FLANGE-90-1 7/16MFOR LBO
25	4	618655	1 7/16FFOX RUN TEE-1 7/16MFOR
26	1	618660	1 1/16FJX BRANCH TEE-1 1/16MJ
27	1	618661	1 5/16FJIC-9/16MJIC ADPTR
28	4	618676	O-RING FOR 1" SPL FLG 618652
29	1	606870	O-RING FOR 606865 SUND B-MT
30	4	900265	1/2UNC X 1 1/2 HEX BOLT
31	4	920504	1/2 LOCK WASHER
32	4	920004	1/2 SAE FLAT WASHER
33	12	618677	O-RING,-16 FACE SEAL .93ID 90D

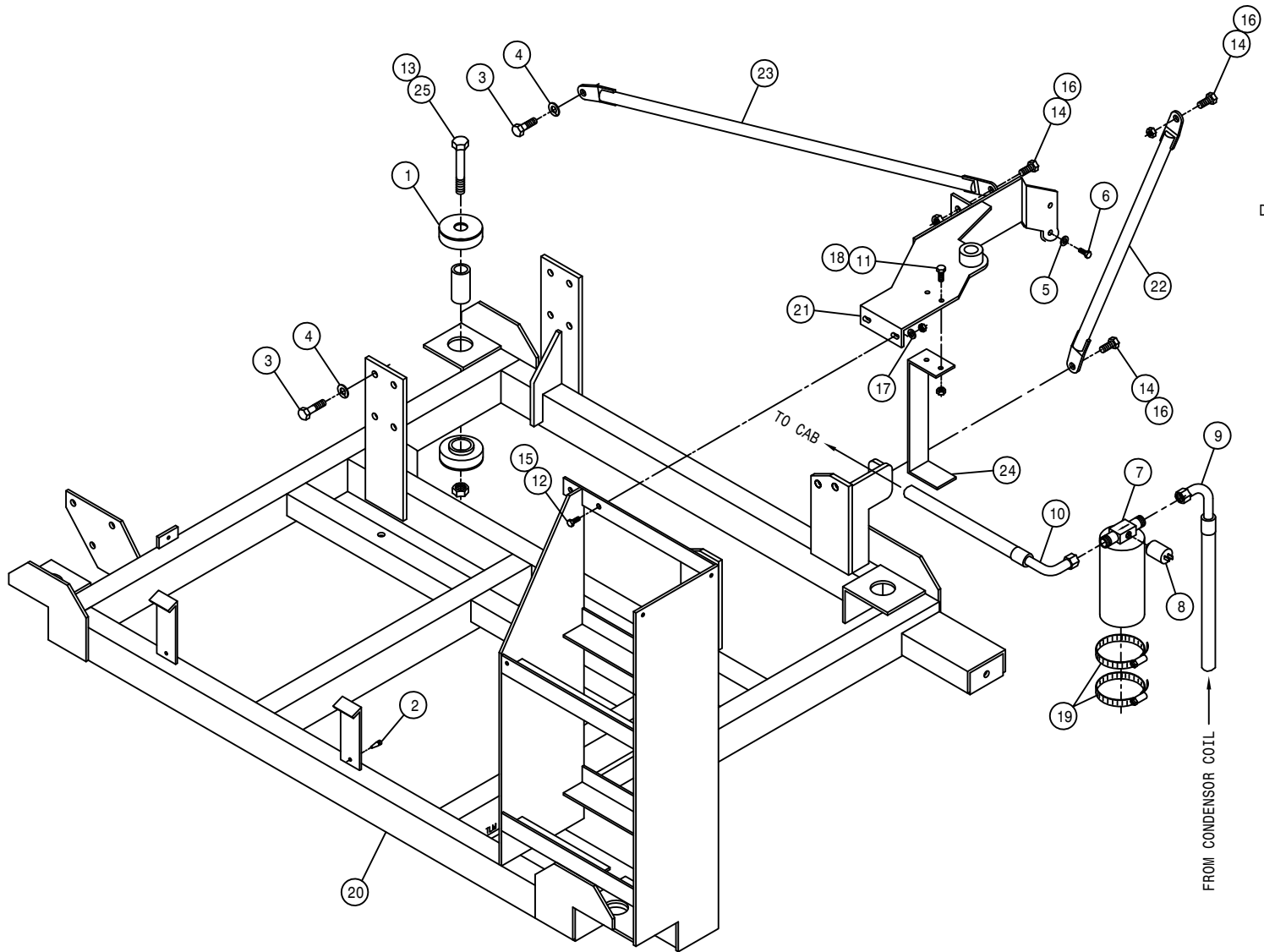

ENGINE SKID ASSEMBLY

DET.	QTY	PART NO.	DESCRIPTION
1	4	311057	RUBBER MT SET,SSB33-1000-4
2	4	470313	GROMMET BUMPER,1/4T X 1/4D MT
3	13	473775	12MM-1.75 X 30MM HEX BOLT
4	13	473784	12MM LOCK WASHER
5	2	473804	8MM LOCK WASHER
6	2	473827	8MM-1.25 X 20MM HEX BOLT
7	1	657421	A/C RECEIVER/DRIER
8	1	657422	A/C BINARY SWITCH
9	1	657443	A/C HOSE,06-06F90-06F90-34"
10	1	657444	A/C HOSE,06-06F90-06F90-115"
11	2	900065	5/16UNC X 1" HEX BOLT
12	2	900129	3/8UNC X 1" HEX BOLT
13	4	914012	3/4UNC HEX STOVER NUT
14	3	900264	1/2UNC X 1 1/4 HEX BOLT
15	2	914004	3/8UNC HEX STOVER NUT
16	3	914008	1/2UNC HEX STOVER NUT
17	2	920002	3/8 SAE FLAT WASHER
18	2	914002	5/16UNC HEX STOVER NUT
19	2	520052	HOSE CLAMP NO 52 STAINLESS
20	1	316380	SKID WLD
21	1	316426	RAD MT PLT WLD
22	1	316433	RH RAD BRACE WLD
23	1	316434	LH RAD BRACE WLD
24	1	316432	A/C DRYER MT
25	4	900408	3/4UNC X 3 1/2 HEX BOLT

AIR CLEANER ASSEMBLY

DET. QTY PART NO. DESCRIPTION

1	1	311520	ENGINE PRE CLEANER
2	1	311514	AIR CLEANER, 14" STS 03
3	2	311517	AIR CLEANER MT BAND,14" STS 03
4	1	311515	PRIMARY AIR FILTER FOR 311514
5	1	311505	4.00 90 DEG COBRA ELBOW,RUBBER
6	1	311506	5.50-4.00 ID REDUCER BUSHING
7	1	311507	4.00" 45DEG ELBOW, RUBBER
8	1	311521	6.00 - 5.50 45DEG ELBOW,RUBBER
9	1	311516	SAFETY ELEMENT FOR 311514
10	1	311518	AIR CLEANER HOOD EXT,6" X 8"LG
11	1	316068	4" X 6.00" AIR INTAKE TUBE
12	1	316344	4" X 4.00" AIR INTAKE TUBE 98
13	1	470354	MUFFLER CLAMP, 6.00
14	2	473775	12MM-1.75 X 30MM HEX BOLT
15	2	473784	12MM LOCK WASHER
16	2	473798	10MM LOCK WASHER
17	2	473818	10MM-1.50 X 40MM HEX BOLT
18	2	900072	5/16UNC X 3" HEX BOLT
19	2	473843	12MM FLAT WASHER
20	1	520117	CUSH HOSE CLAMP 5/8D X 1/2W
21	4	520134	4.31/4.59 T-BOLT HOSE CLAMP SS
22	1	520144	5.94/6.21 T-BOLT HOSE CLAMP SS
23	1	601474	HOSE, 1/4 X 26 AIR
24	1	520147	6.38/6.69 T-BOLT HOSE CLAMP
25	1	711036	1/8MNPT-1/4 NYL TUBE FTG
26	1	711039	1/8MNPT-1/4 NYL TUBE LBO
27	1	900000	1/4UNC X 1/2 HEX BOLT
28	1	470118	1/4UNC X 3/4 FLANGE HEX BOLT
29	5	900129	3/8UNC X 1" HEX BOLT
30	1	914000	1/4UNC HEX STOVER NUT
31	2	914002	5/16UNC HEX STOVER NUT
32	5	914004	3/8UNC HEX STOVER NUT
33	8	920002	3/8 SAE FLAT WASHER
34	1	316464	AIR CLEANER MT WLD
35	1	316468	DIPSTICK MTG BRKT
36	1	470121	1/4UNC HEX FLANGE LOCK NUT
37	1	601478	HOSE, 1/4 X 175 AIR
38	1	291703	BATT CABLE,BLK 12"6GA 3/8-3/8
39	1	316277	AIR COMPRESSOR GOVERNOR KIT
40	1	311519	7.01 - 5.90 REDUCE BOOT,RUBBER

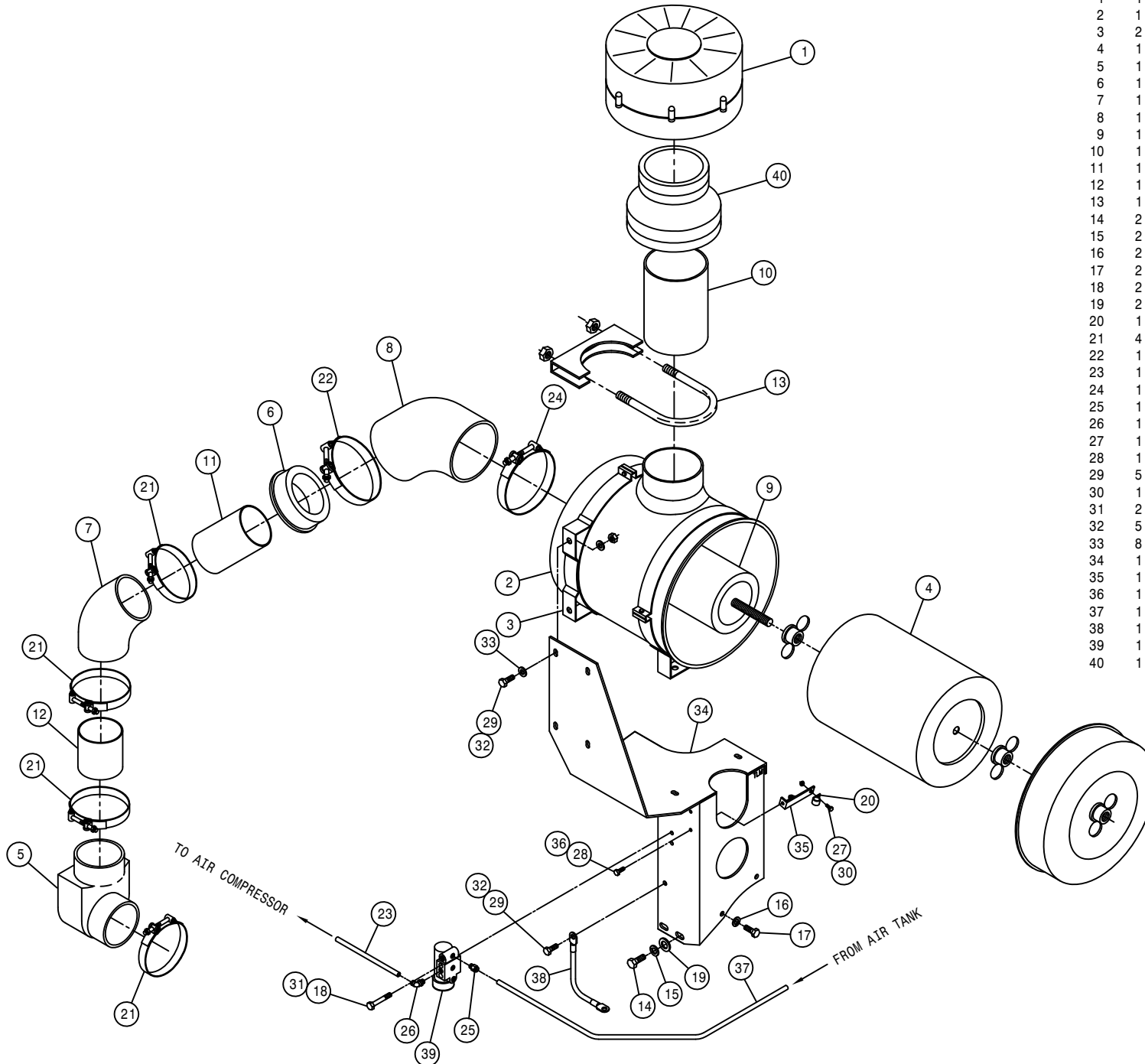

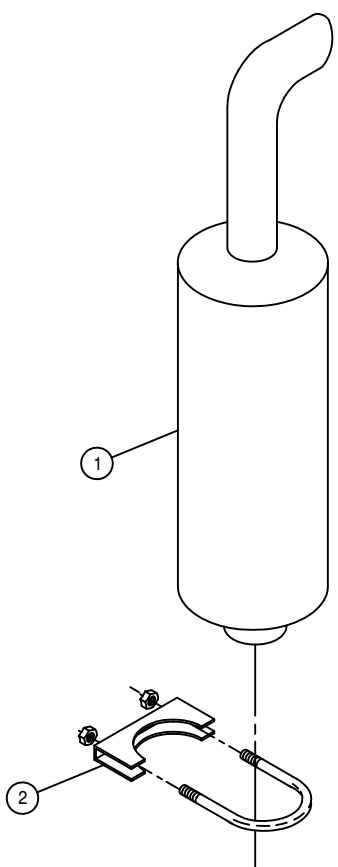

MUFFLER ASSEMBLY

DET. QTY PART NO. DESCRIPTION

1	1	316366	MUFFLER, 2100/STS10/STS12
2	1	470160	MUFFLER CLAMP 3.00 IN

RADIATOR AND OIL COOLER ASSEMBLY

DET. QTY PART NO. DESCRIPTION

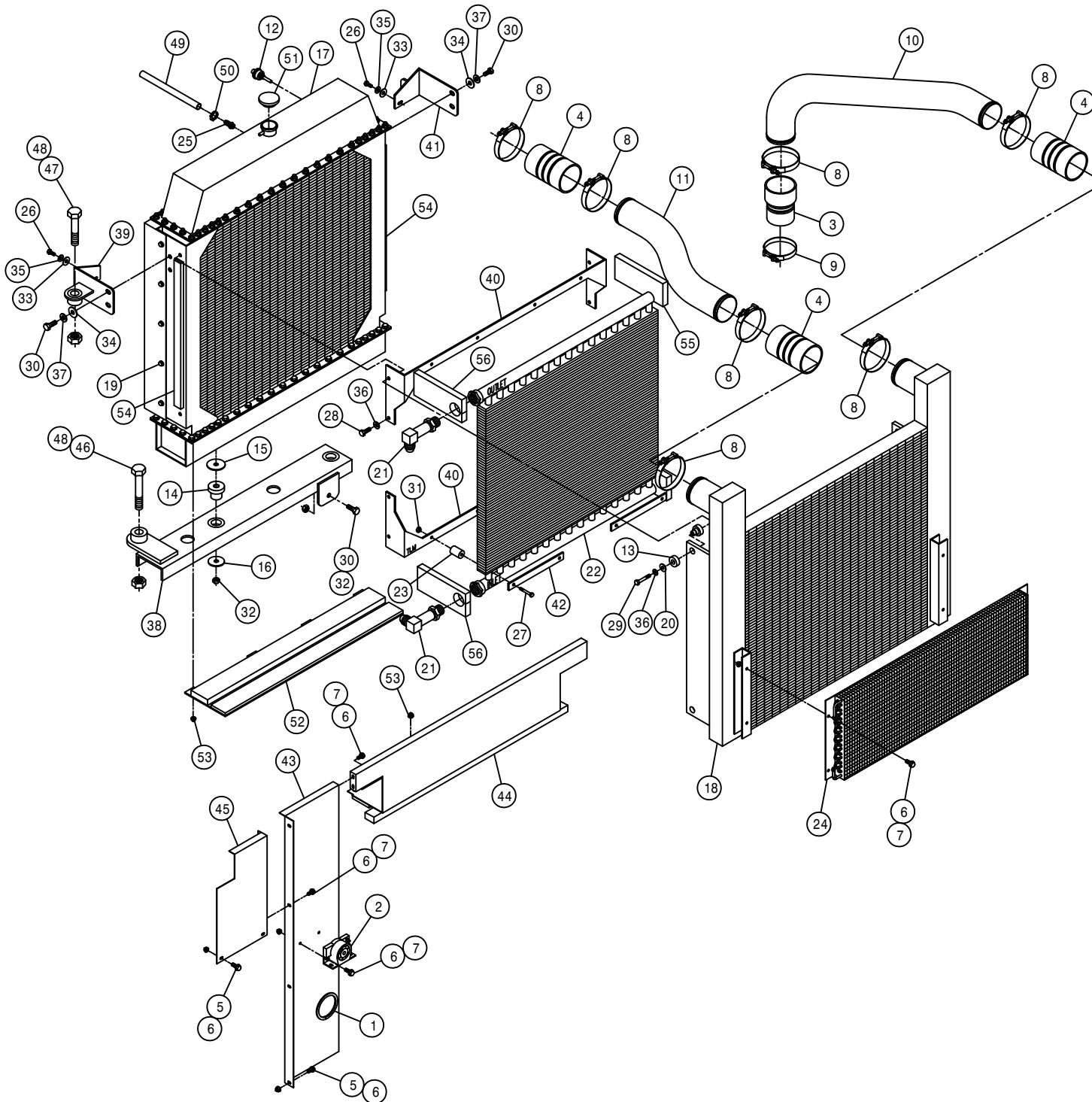

DET.	QTY	PART NO.	DESCRIPTION
1	1	193012	QUICKEDGE TRIM .135 TO .250
2	1	291759	BACK-UP WARNING BEEPER, 112DB
3	1	311500	3.00-3.50 CAC HOSE, AIR INTAKE
4	3	311501	3.50 CAC HOSE, AIR INTAKE
5	4	470118	1/4UNC X 3/4 FLANGE HEX BOLT
6	14	470121	1/4UNC HEX FLANGE LOCK NUT
7	10	470122	1/4UNC X 1/2 FLANGE HEX BOLT
8	7	520145	356 T-BOLT HOSE CLAMP SS
9	1	520146	306 T-BOLT HOSE CLAMP SS
10	1	316459	RIGHT CHARGE AIR COOLER PIPE
11	1	316460	LEFT CHARGE AIR COOLER PIPE
12	1	291714	WATER LEVEL SENSOR
13	4	311056	RUBBER MOUNT SET,2-PC CB 2320
14	2	311060	RUBBER MOUNT,1-PC CB-1122-2
15	2	311061	HEAD WASHER FOR 311060
16	2	311062	TAIL WASHER FOR 311060
17	1	316364	RADIATOR, STS12 2000
18	1	316365	CHARGE AIR COOLER, STS12 2000
19	10	470319	3/8UNC X 1/2 FLANGE HEX BOLT
20	4	483043	3/8 REGULAR FLAT WASHER
21	2	618463	1 5/16MJIC-90-1 5/16MOR XL LBO
22	1	618800	OIL COOLER STS12 2000
23	8	618801	MOUNTING KIT FOR 618800 COOLER
24	1	657434	A/C CONDENSER COIL 21-0302
25	1	783304	1/4 NPT X 3/8 HOSE BARB, BRS
26	2	900064	5/16UNC X 3/4 HEX BOLT
27	8	900071	5/16UNC X 2 3/4 HEX BOLT
28	4	900128	3/8UNC X 3/4 HEX BOLT
29	4	900133	3/8UNC X 2" HEX BOLT
30	5	900264	1/2UNC X 1 1/4 HEX BOLT
31	8	914002	5/16UNC HEX STOVER NUT
32	3	914008	1/2UNC HEX STOVER NUT
33	2	920001	5/16 SAE FLAT WASHER
34	4	920004	1/2 SAE FLAT WASHER
35	2	920501	5/16 LOCK WASHER
36	8	920502	3/8 LOCK WASHER
37	4	920504	1/2 LOCK WASHER
38	1	316439	RAD MT WLD
39	1	316447	UPPER LH RAD MT WLD
40	2	316452	RAD TO OIL COOLER MT
41	1	316446	UPPER RH RAD MT WLD 2000
42	4	316453	RAD TO OIL COOLER KEEPER
43	1	316457	BATTERY BOX FILLER PANEL
44	1	316487	UPR RADIATOR FILLER PANEL ASSY
45	1	316458	UPPER BATTERY BOX FILLER
46	1	900540	1" UNC X 7" HEX BOLT
47	1	900541	1" UNC X 3 3/4" HEX BOLT
48	2	914016	1" UNC HEX STOVER NUT
49	1	601472	HOSE, 3/8 X 24 HEATER
50	1	520069	HOSE CLAMP NO 6 STAINLESS
51	1	316377	RAD CAP, 10LB 10237
52	1	316490	LWR RADIATOR FILLER PANEL ASSY
53	8	470113	5/16UNC HEX FLANGE LOCK NUT
54	2	316493	SIDE FOAM,RAD/CAC
55	2	316494	RH UPR/LWR FOAM,OIL CLR/RAD 00
56	2	316495	LH UPR/LWR FOAM,OIL CLR/RAD 00

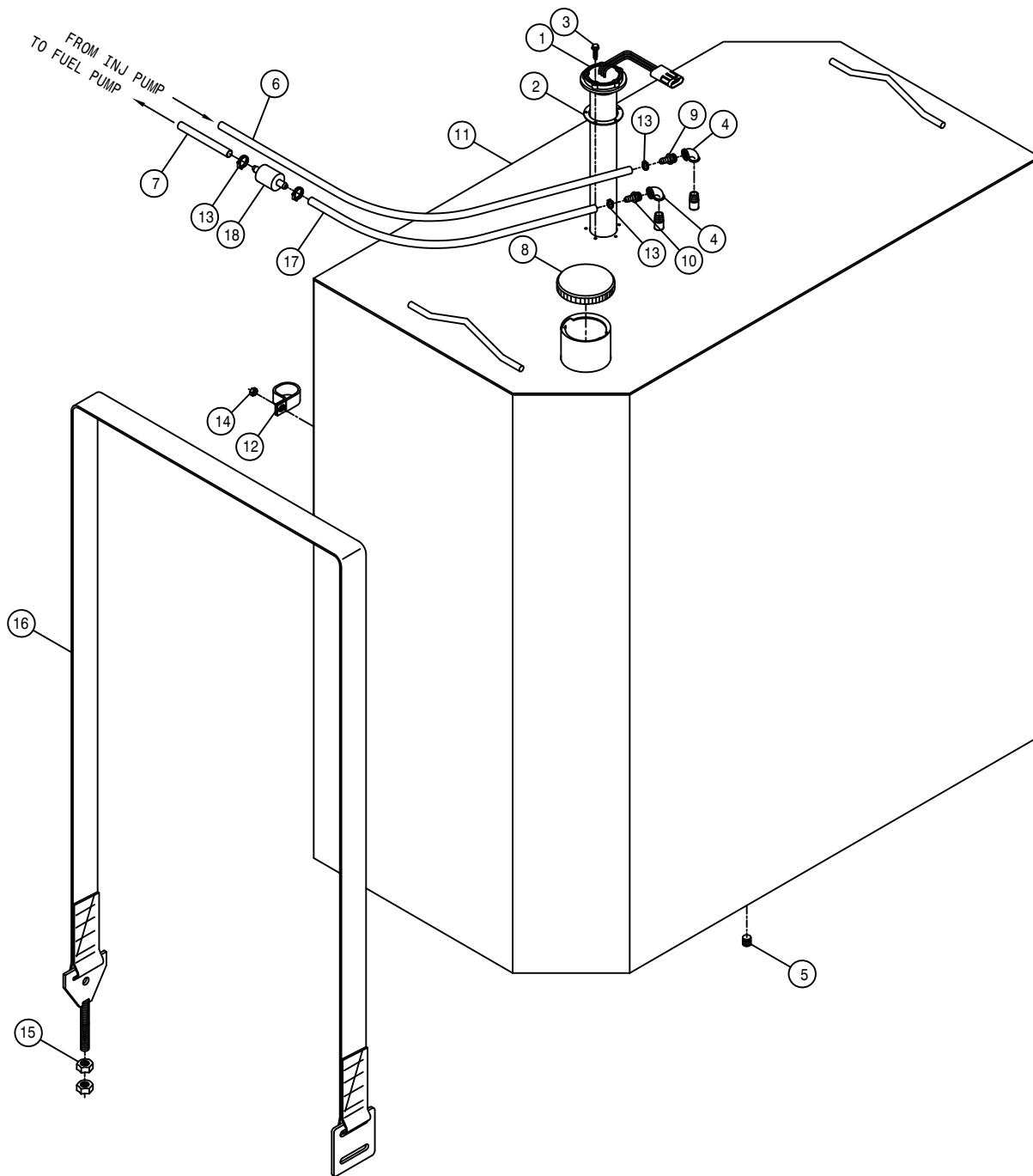

FUEL TANK ASSEMBLY

DET.	QTY	PART NO.	DESCRIPTION
1	1	291788	FUEL SENDER
2	1	291789	GASKET FOR FUEL SENDER 291788
3	5	472347	#10 X 1 1/4 SELF DRILL/TAP SCR
4	2	501451	BLK PIPE EL 90DEG .25NPT
5	1	503703	PIPE PLUG .50NPT SKT HD
6	1	601300	HOSE, 5/16 X 60 FUEL LINE
7	1	601550	HOSE, 3/8 X 22 FUEL LINE
8	1	761202	FUEL TANK CAP, 3" VENTED, ZINCPL
9	1	783303	1/4 NPT X 5/16 HOSE BARB, BRS
10	1	783304	1/4 NPT X 3/8 HOSE BARB, BRS
11	1	760251	FUEL TANK WLD
12	1	520100	CUSH HOSE CLAMP, 1 1/2D X 1/2W
13	4	520120	HOSE CLAMP NO 4 STAINLESS
14	1	914000	1/4UNC HEX STOVER NUT
15	4	910008	1/2UNC HEX NUT
16	2	316473	FUEL TANK HOLD-DOWN STRAP ASSY
17	1	601551	HOSE, 3/8 X 38 FUEL LINE
18	1	316281	FUEL STRAINER, IN-LINE, DIESEL

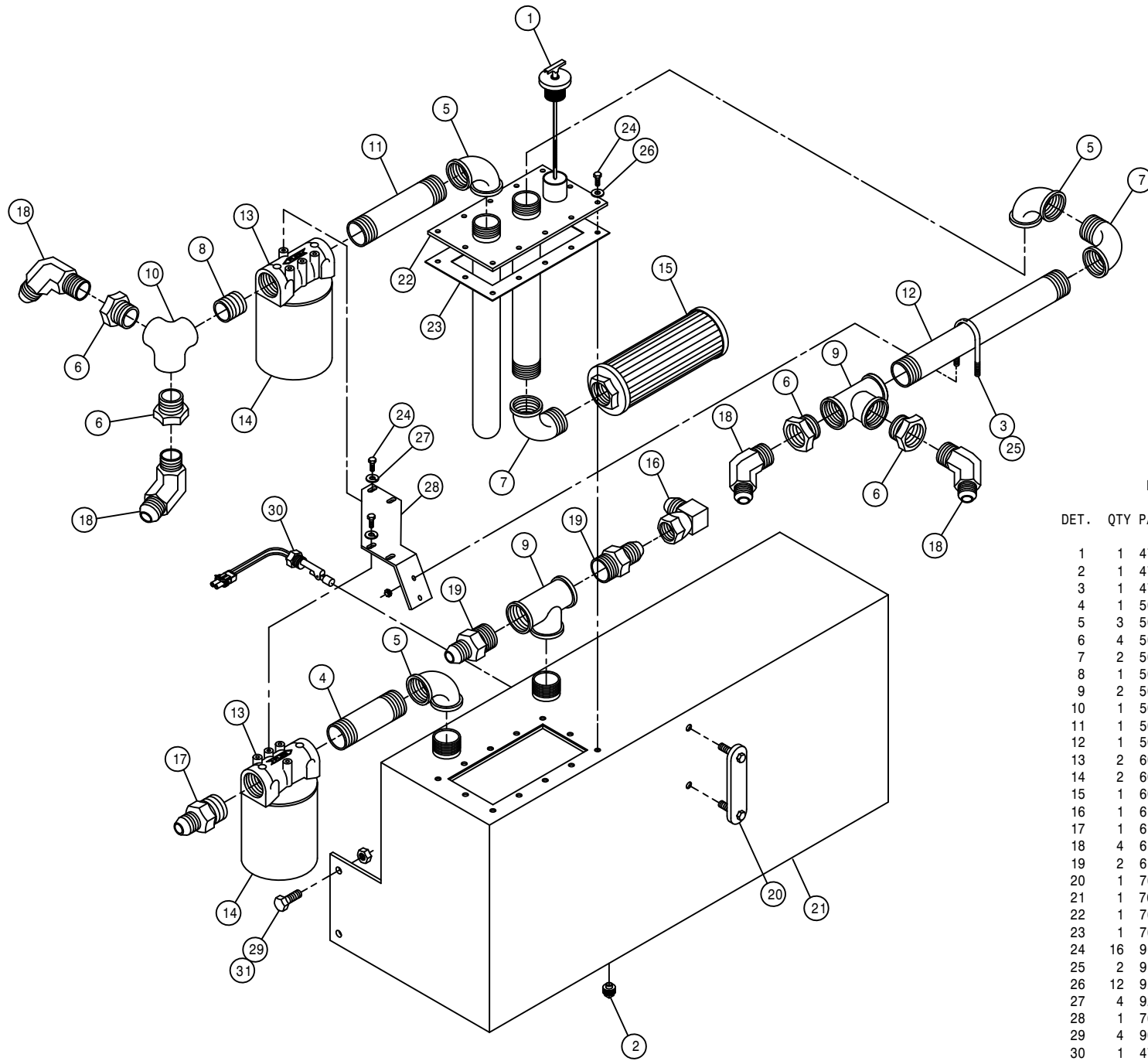

HYDRAULIC TANK ASSEMBLY

DET.	QTY	PART NO.	DESCRIPTION
	1	470293	DIPSTICK, VENTED
	1	470308	1/2MNPT DRAIN PLUG,AL HD,MAG
	3	473971	1/4UNC-2"ID-3"RD U-BOLT
	4	507009	BLK PIPE NIPPLE 1.50NPT-6.00
	5	507014	BLK PIPE EL 90DEG 1.50NPT
	6	507015	RED BUSH 1.50NPT - 1.25FNPT
	7	507018	BLK PIPE ST EL 90DEG 1.50NPT
	8	507019	CLOSE NIPPLE 1.50NPT
	9	507250	BLK PIPE TEE 1.50NPT
	10	507252	SIDE OUTLET EL 90DEG 1.50NPT
	11	507610	BLK PIPE NIPPLE 1.50NPT-8.00
	12	507617	BLK PIPE NIPPLE 1.50NPT-16.00
	13	605611	FILTER HEAD, 1 1/2FNPTF ZINGA
	14	605612	FILTER, 10 MICRON ZINGA
	15	605613	TANK FILTER,100 MESH,1 1/2FNPT
	16	618640	1 5/16MJ-90-1 5/16FJ SWIV LBO
	17	618656	1 5/8MJIC-1 1/2MNPT ADPTR
	18	618667	1 5/16MJIC-45-1 1/4MNPT LBO
	19	618672	1 5/16MJIC-1 1/2MNPT ADPTR
	20	760177	SIGHT GAUGE W/TEMP, HYD TANK
	21	760231	HYD TANK WLD STS12
	22	760239	RECEIVER PLATE WLD STS12
	23	760243	GASKET, RECEIVER PLATE STS12
	24	900064	5/16UNC X 3/4 HEX BOLT
	25	914000	1/4UNC HEX STOVER NUT
	26	920001	5/16 SAE FLAT WASHER
	27	920501	5/16 LOCK WASHER
	28	760245	HYD FILTER KEEPER
	29	900264	1/2UNC X 1 1/4 HEX BOLT
	30	470350	LIQUID LEVEL SWITCH,1/2MNPT O2
	31	914008	1/2UNC HEX STOVER NUT

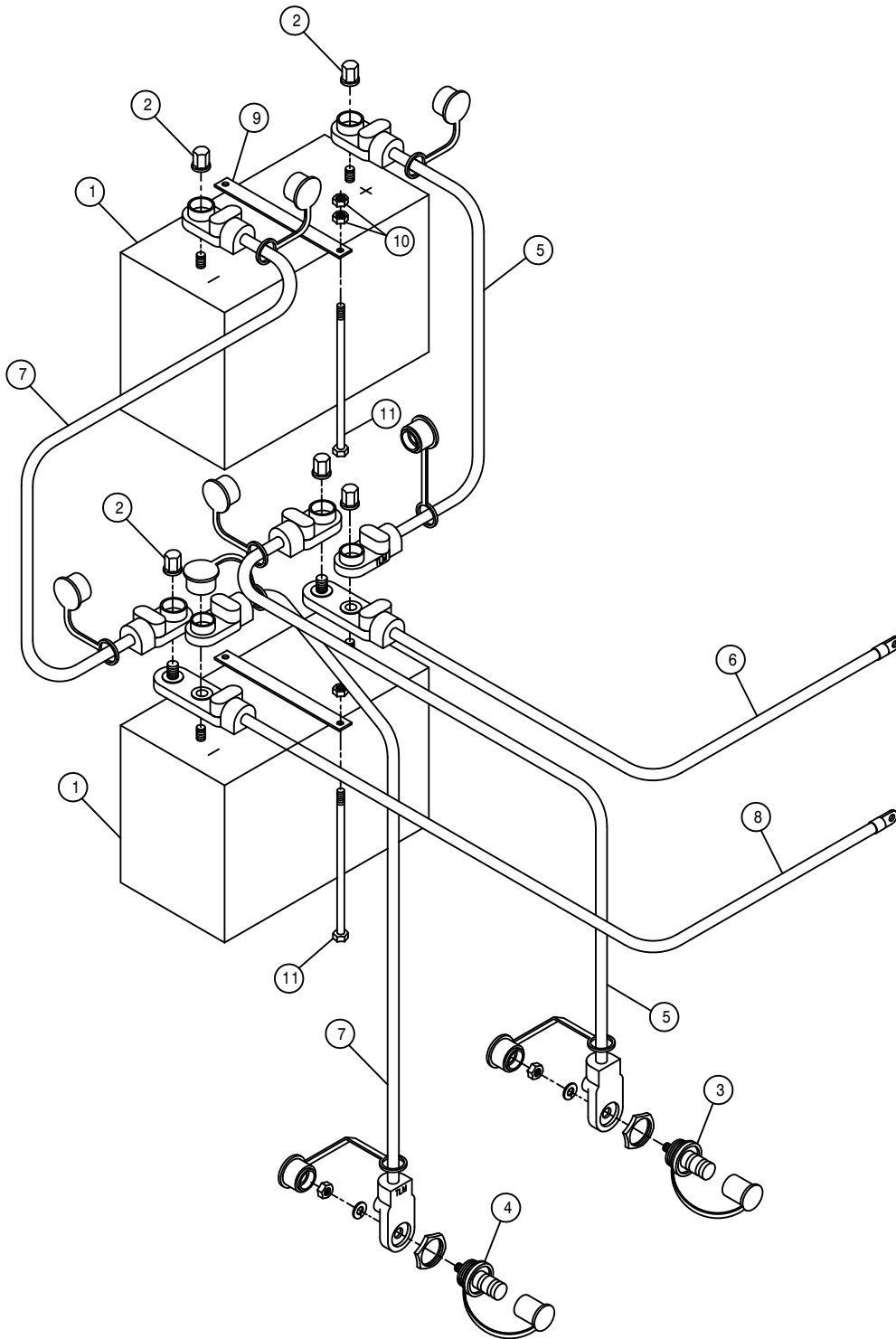

BATTERY ASSEMBLY

DET. QTY PART NO. DESCRIPTION

1	2	291196	BATTERY, 12V 950CCA, SS STUD
2	6	291205	BATTERY NUT, 3/8-16 SS CLSD CAP
3	1	291680	POSITIVE JUMPER STUD, RED
4	1	291681	NEGATIVE JUMPER STUD, BLACK
5	2	291705	BATT CABLE, RED 26*2/0 3/8-3/8
6	1	291706	BATT CABLE, RED 70*2/0 3/8-3/8
7	2	291707	BATT CABLE, BLK 26*2/0 3/8-3/8
8	1	291708	BATT CABLE, BLK 73*2/0 3/8-3/8
9	2	316470	BATTERY TIE-DOWN
10	8	910004	3/8UNC HEX NUT
11	4	900150	3/8UNC X 9 1/2 HEX BOLT

AIR TANK ASSEMBLY

DET. QTY PART NO. DESCRIPTION

1	1	470266	DRAIN VALVE KIT, 1/4NPT
2	1	504000	RED BUSH 3/4 TO 3/8
3	1	504610	BLK PIPE ST EL 90DEG .75NPT
4	8	920002	3/8 SAE FLAT WASHER
5	4	900130	3/8UNC X 1 1/4 HEX BOLT
6	1	701154	AIR TANK
7	1	503013	RED BUSH 3/4MNPT-1/2FNPT,STEEL
8	1	711037	1/2MNPT-1/2 NYL TUBE FTG
9	1	711041	3/8MNPT-3/8 NYL TUBE LBO
10	4	914004	3/8UNC HEX STOVER NUT
11	2	711046	3/8MNPT-1/4 NYL TUBE TRPL LBO
12	1	601476	HOSE, 1/4 X 120 AIR
13	1	601477	HOSE, 1/4 X 160 AIR
14	1	601478	HOSE, 1/4 X 175 AIR
15	1	601479	HOSE, 1/4 X 196 AIR
16	1	601480	HOSE, 1/4 X 230 AIR
17	1	601587	HOSE, 3/8 X 102 AIR
18	1	601483	HOSE, 1/2 X 84 AIR
19	1	601486	HOSE, 1/4 X 215 AIR

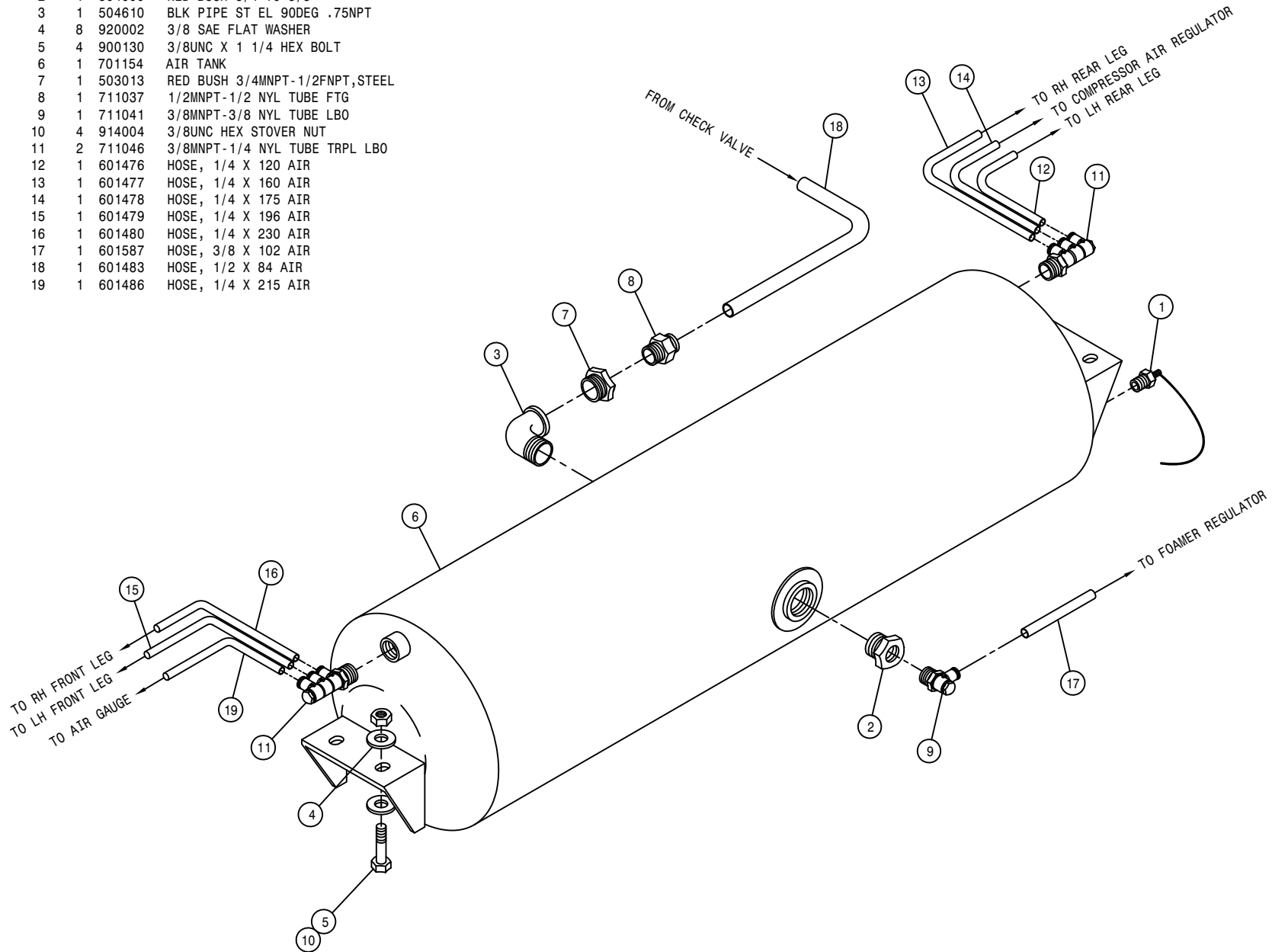

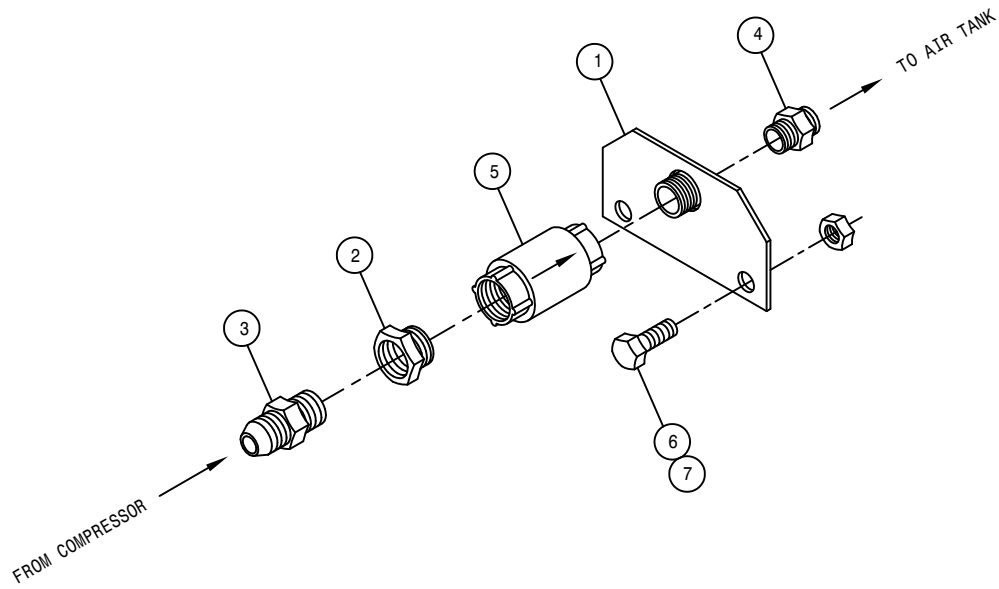

AIR CHECK VALVE ASSEMBLY

DET.	QTY	PART NO.	DESCRIPTION
1	1	316538	AIR CHECK VLV BRKT WLD STS10
2	1	503013	RED BUSH 3/4MNPT-1/2FNPT,STEEL
3	1	618325	7/8MJIC-1/2MNPT ADPTR
4	1	711037	1/2MNPT-1/2 NYL TUBE FTG
5	1	711050	3/4\"/>
6	2	900263	1/2UNC X 1\"/>
7	2	914008	1/2UNC HEX STOVER NUT

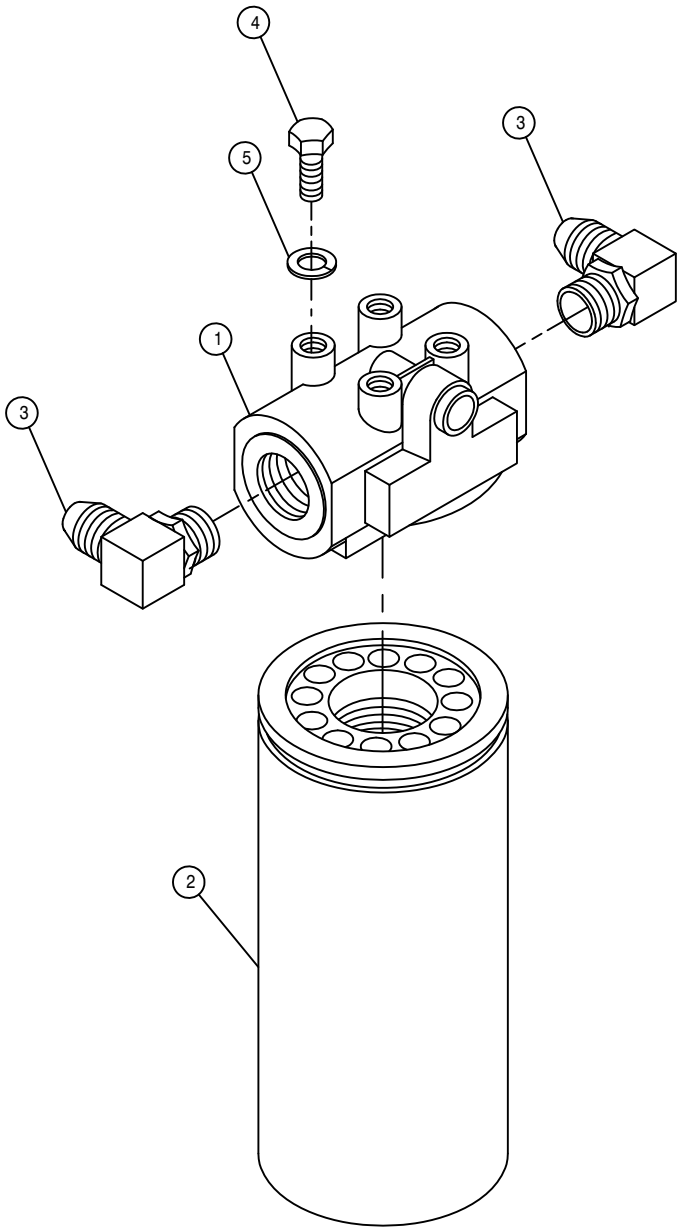

HI-PRESS FILTER ASSEMBLY

DET. QTY PART NO. DESCRIPTION

1	1	605608	HYD FILTER HEAD, DONALDSON
2	1	605609	HYD FILTER ELEMENT, DONALDSON
3	2	618474	3/4MJIC-90-1 1/16MOR LBO
4	4	900128	3/8UNC X 3/4 HEX BOLT
5	4	920502	3/8 LOCK WASHER

LADDER AND BRAKE VALVE ASSEMBLY

DET. QTY PART NO. DESCRIPTION

DET.	QTY	PART NO.	DESCRIPTION
1	1	606011	LADDER/BRKWAY VLV W/TOWER ASSY
2	1	606013	BRAKE VLV W/TOWER ASSY
3	1	618126	9/16MJIC-9/16MOR ADPTR
4	3	618119	9/16MJIC-90-9/16MOR LBO
5	1	618486	9/16FJIC SW RUN TEE-9/16MJIC
6	1	618618	9/16MJIC-90-9/16FJIC SWIV LBO
7	1	618444	9/16MOR RUN TEE-9/16MJIC
8	2	900012	1/4UNC X 3 1/2 HEX BOLT
9	2	470121	1/4UNC HEX FLANGE LOCK NUT
10	1	342824	TRD ADJ HARNESS CONNECTOR BRKT
11	1	342826	SOLE VLV SPACER
12	2	914000	1/4UNC HEX STOVER NUT
13	2	610185	9/16MOR PLUG

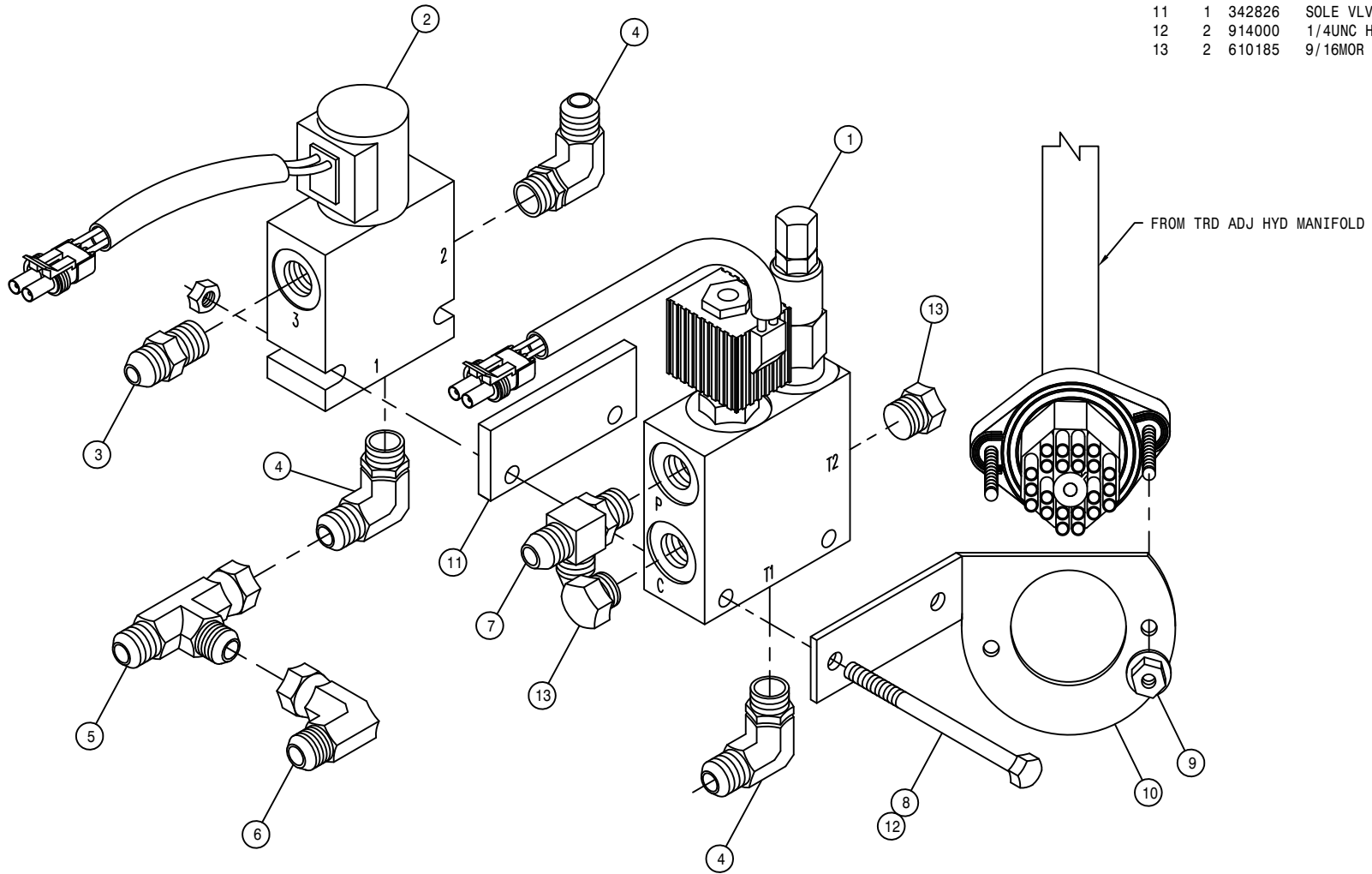

RIGHT FRONT OUTER LEG ASSEMBLY

DET. QTY PART NO. DESCRIPTION

1	2	121029	JOURNAL BRG, 1.00 ID X 1.00 LG
2	1	125050	BRG CONE, 1.00 ID W/FACE SEAL
3	1	125051	BRG CUP FOR 125050
4	1	125052	BRG CONE, 2.687 ID W/FACE SEAL
5	1	125053	BRG CUP FOR 125052
6	2	311058	RUBBER SPRING
7	1	311066	AIRIDE SPRING, STS12
8	1	311067	HEIGHT CONTROL AIR VALVE
9	1	311069	7.00 LEVER, CTRL AIR VLV 311067
10	1	311070	LEVER SCREW, CTRL AIR VLV311067
11	1	359005	OUTER LEG WLD, 72" STS12 00
12	1	470305	HOSE CLAMP, 4-HOLE
13	1	471005	1/4 28 X 1/2 GREASE ZERK
14	1	473975	ROD END, 1.00 BORE, 1-12 RH MALE
15	1	621063	STEERING CYL ASSY STS 03
16	2	629536	RETAINING RING, 6.00 INT SPIRAL
17	2	711036	1/8MNPT-1/4 NYL TUBE FTG
18	1	711040	1/4MNPT-1/4 NYL TUBE LBO
19	1	472328	1" -12 HEX JAM NUT
20	2	900006	1/4UNC X 1 3/4 HEX BOLT
21	16	900129	3/8UNC X 1" HEX BOLT
22	2	900138	3/8UNC X 3 1/2 HEX BOLT
23	4	900265	1/2UNC X 1 1/2 HEX BOLT
24	8	900267	1/2UNC X 2" HEX BOLT
25	4	900269	1/2UNC X 2 3/4 HEX BOLT
26	1	900343	5/8UNC X 4 1/2 HEX BOLT
27	2	900352P	5/8UNC X 2 1/4 HEX BOLT
28	1	359085	STEERING ARM BOLT, 1"-8THD STS
29	1	910008	1/2UNC HEX NUT
30	1	910013	3/4UNF HEX NUT
31	1	910021	1" -14 SLOT JAM NUT
32	2	914000	1/4UNC HEX STOVER NUT
33	2	914004	3/8UNC HEX STOVER NUT
34	12	914008	1/2UNC HEX STOVER NUT
35	1	914010	5/8UNC HEX STOVER NUT
36	1	910020	1" UNC HEX SLOTTED NUT
37	1	920008	1" SAE FLAT WASHER
38	16	920502	3/8 LOCK WASHER
39	5	920504	1/2 LOCK WASHER
40	1	920506	3/4 LOCK WASHER
41	2	359084	WASH, 14GA X 4.75ID X 5.875OD
42	1	359057	RH AIR BAG LOWER PLT WLD
43	1	359052	AIR BAG TOWER TOP MT WLD
44	2	359077	NITRO TOWER SHAFT WLD STS
45	1	359082	STEERING ARM BRG SPACER
46	2	121100	LEG SLEEVE BEARING, ORKOT
47	1	359070	RH STEERING ARM WLD
48	1	359049	RH LEG AIR VALVE MT
49	1	359051	LWR AIR VALVE ARM MT
50	1	359081	UPPER LEG HOSE MT PLT
51	1	342719	TRD ADJ BRONZE BEARING, TAPPED
52	2	121105	LEG TOWER SLIDE BEARING, ORKOT
53	1	359094	HYD TUBE CLAMP KEEPER, 5.75
54	1	359095	LEG HEIGHT CTRL LINKAGE, STS12
55	1	359068	UPPER TRUNNION MT PLT WLD
56	1	601473	HOSE, 1/4 X 22 AIR
57	1	601480	HOSE, 1/4 X 230 AIR
58	1	470310	SIDEWINDER SLEEVE, 13.50 X 45"
59	1	471021	GREASE ZERK 1/8 NPT STRAIGHT
60	2	914010P	5/8UNC HEX STOVER NUT
61	1	470117	COTTER PIN 3/16 1 3/4 SQ CUT
62	3	342917	TREAD ADJ PLATE, STEEL STS10
63	1	483018	1" EXTERNAL TOOTH LOCK WASHER

*NOTE: FOR TREAD ADJUST OPTION REPLACE ITEM 62 WITH THREE OF ITEM 51.

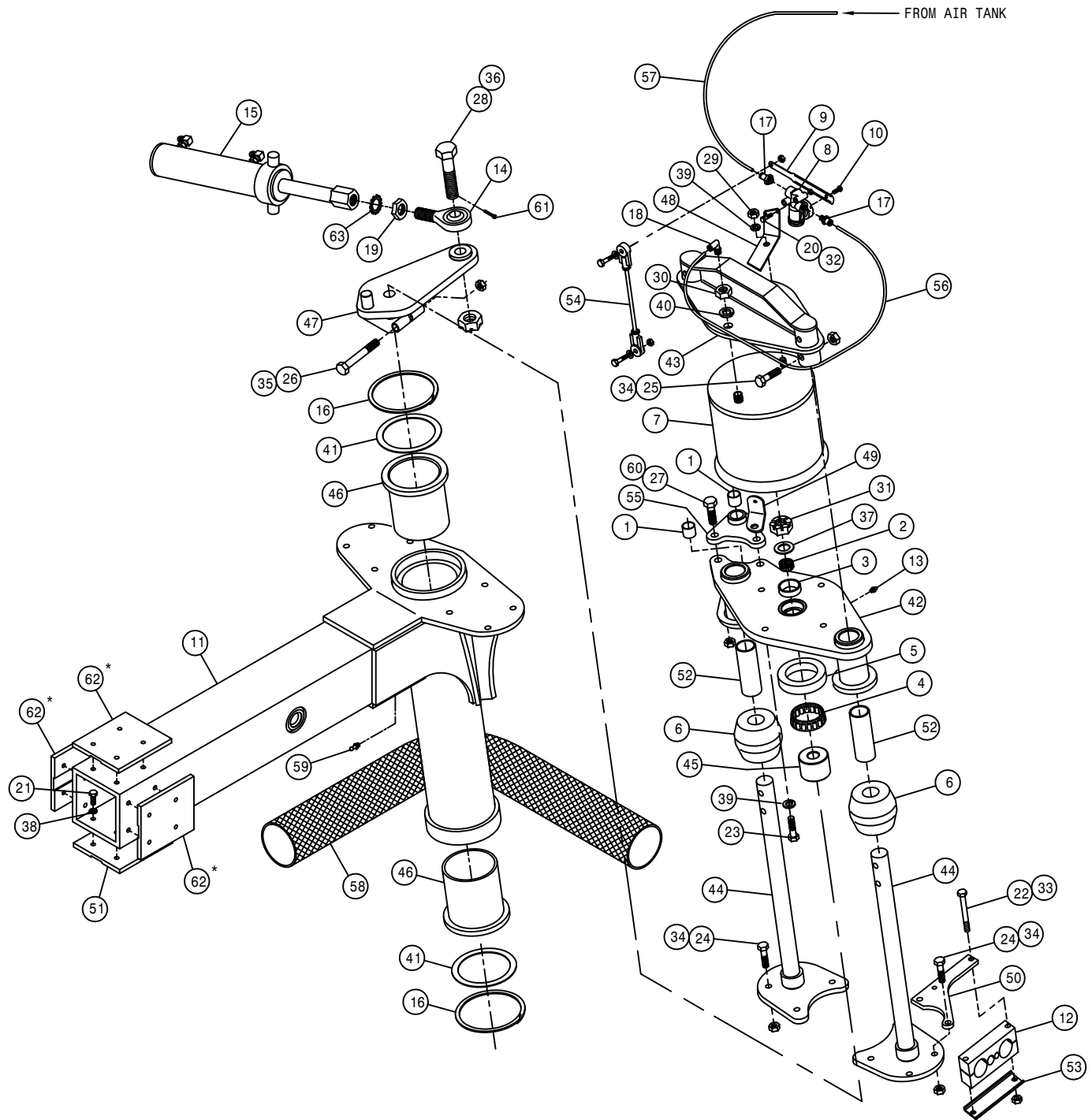

RIGHT FRONT INNER LEG ASSEMBLY

DET. QTY PART NO. DESCRIPTION

1	1	359004	INNER LEG WLD, 72" STS12 00
2	1	470117	COTTER PIN 3/16 1 3/4 SQ CUT
3	1	470305	HOSE CLAMP, 4-HOLE
4	2	473838	20MM-1.5 X 40MM HEX BOLT 8.8
5	2	473839	20MM FLAT WASHER
6	17	473840	16MM-2.00 X 40MM HEX BOLT 8.8
7	17	473841	16MM LOCK WASHER
8	1	606978	SUND HYD MOTOR
9	1	610711	TORQ HUB, 22:1 CW12
10	2	618652	1" SPLIT FLANGE KIT
11	2	618676	O-RING FOR 1" SPL FLG 618652
12	10	824055	22MM-1.50 FLANGED WHEEL NUT
13	2	900138	3/8UNC X 3 1/2 HEX BOLT
14	4	900264	1/2UNC X 1 1/4 HEX BOLT
15	4	900265	1/2UNC X 1 1/2 HEX BOLT
16	2	914004	3/8UNC HEX STOVER NUT
17	8	914008	1/2UNC HEX STOVER NUT
18	1	359105	RH WHL MTR SHIELD, STS10
19	2	359102	WHL MTR SHIELD BRACE
20	1	359096	RH LWR LEG HYD HOSE MT WLD
21	1	359094	HYD TUBE CLAMP KEEPER, 5.75
22	1	470312	SIDEWINDER SLEEVE, 14.00 X 68"
23	1	606018	O-RING, WHL MTR 606978/606981
24	1	618327	3/4MJIC-7/8MOR ADPTR

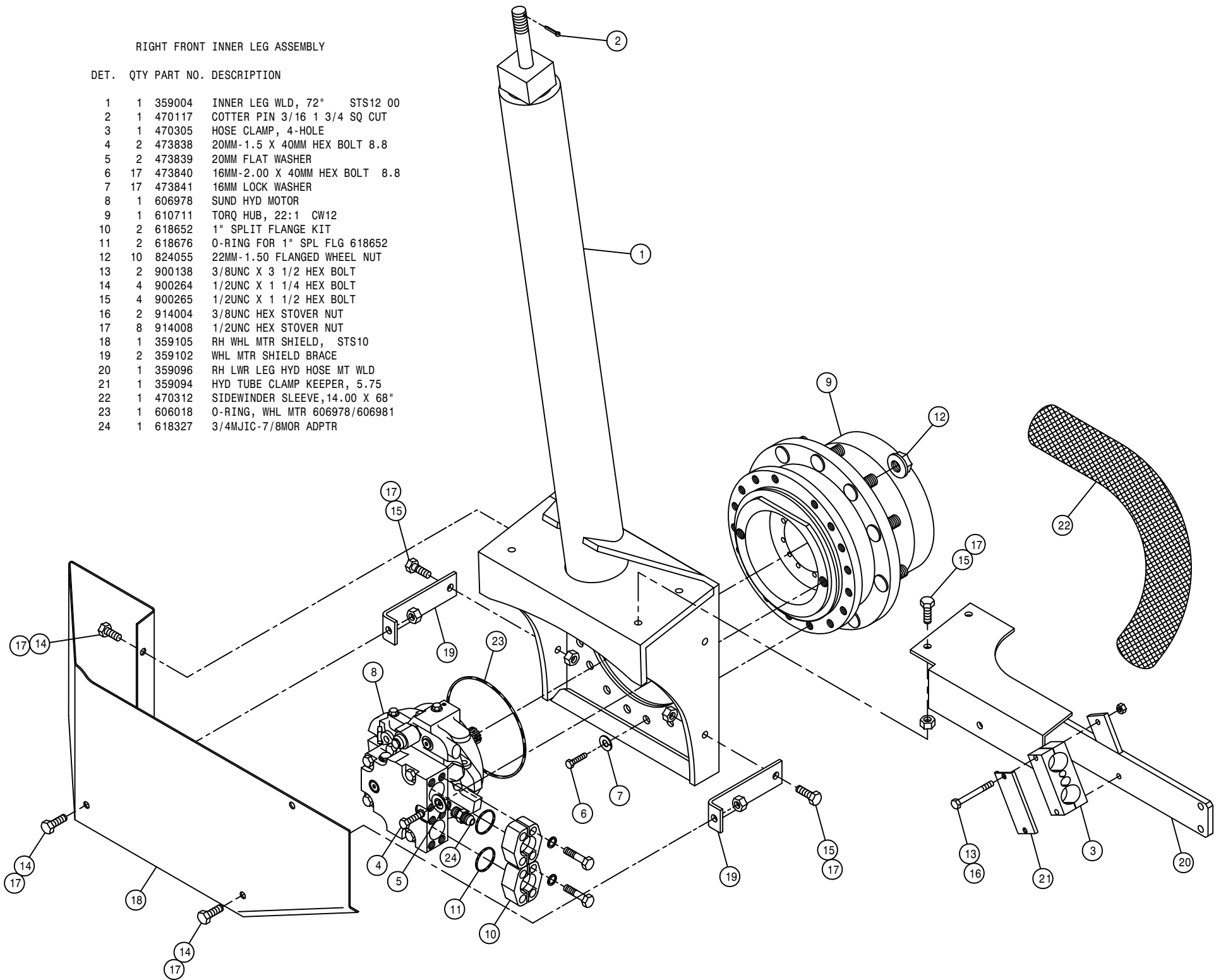

LEFT FRONT OUTER LEG ASSEMBLY

DET. QTY PART NO. DESCRIPTION

DET.	QTY	PART NO.	DESCRIPTION
1	2	121029	JOURNAL BRG, 1.00 ID X 1.00 LG
2	1	125050	BRG CONE, 1.00 ID W/FACE SEAL
3	1	125051	BRG CUP FOR 125050
4	1	125052	BRG CONE, 2.687 ID W/FACE SEAL
5	1	125053	BRG CUP FOR 125052
6	2	311058	RUBBER SPRING
7	1	311066	AIRIDE SPRING, STS12
8	1	311067	HEIGHT CONTROL AIR VALVE
9	1	311069	7.00 LEVER, CTRL AIR VLV 311067
10	1	311070	LEVER SCREW, CTRL AIR VLV311067
11	1	359005	OUTER LEG WLD, 72" STS12 00
12	1	470305	HOSE CLAMP, 4-HOLE
13	1	471005	1/4 28 X 1/2 GREASE ZERK
14	1	473975	ROD END, 1.00 BORE, 1-12 RH MALE
15	1	621063	STEERING CYL ASSY STS 03
16	2	629536	RETAINING RING, 6.00 INT SPIRAL
17	2	711036	1/8MNPT-1/4 NYL TUBE FTG
18	1	711040	1/4MNPT-1/4 NYL TUBE LBO
19	1	472328	1"-12 HEX JAM NUT
20	2	900006	1/4UNC X 1 3/4 HEX BOLT
21	16	900129	3/8UNC X 1" HEX BOLT
22	2	900138	3/8UNC X 3 1/2 HEX BOLT
23	4	900265	1/2UNC X 1 1/2 HEX BOLT
24	8	900267	1/2UNC X 2" HEX BOLT
25	4	900269	1/2UNC X 2 3/4 HEX BOLT
26	1	900343	5/8UNC X 4 1/2 HEX BOLT
27	2	900352P	5/8UNC X 2 1/4 HEX BOLT
28	1	359085	STEERING ARM BOLT, 1"-8THD STS
29	1	910008	1/2UNC HEX NUT
30	1	910013	3/4UNF HEX NUT
31	1	910021	1"-14 SLOT JAM NUT
32	2	914000	1/4UNC HEX STOVER NUT
33	2	914004	3/8UNC HEX STOVER NUT
34	12	914008	1/2UNC HEX STOVER NUT
35	1	914010	5/8UNC HEX STOVER NUT
36	1	910020	1" UNC HEX SLOTTED NUT
37	1	920008	1" SAE FLAT WASHER
38	16	920502	3/8 LOCK WASHER
39	5	920504	1/2 LOCK WASHER
40	1	920506	3/4 LOCK WASHER
41	2	359084	WASH, 14GA X 4.75ID X 5.8750D
42	1	359058	LH AIR BAG LOWER PLT WLD
43	1	359052	AIR BAG TOWER TOP MT WLD
44	2	359077	NITRO TOWER SHAFT WLD STS
45	1	359082	STEERING ARM BRG SPACER
46	2	121100	LEG SLEEVE BEARING, ORKOT
47	1	359071	LH STEERING ARM WLD
48	1	359050	LH LEG AIR VALVE MT
49	1	359051	LWR AIR VALVE ARM MT
50	1	359081	UPPER LEG HOSE MT PLT
51	1	342719	TRD ADJ BRONZE BEARING, TAPPED
52	2	121105	LEG TOWER SLIDE BEARING, ORKOT
53	1	359094	HYD TUBE CLAMP KEEPER, 5.75
54	1	359095	LEG HEIGHT CTRL LINKAGE, STS12
55	1	359068	UPPER TRUNNION MT PLT WLD
56	1	601473	HOSE, 1/4 X 22 AIR
57	1	601479	HOSE, 1/4 X 196 AIR
58	1	470310	SIDEWINDER SLEEVE, 13.50 X 45"
59	1	471021	GREASE ZERK 1/8 NPT STRAIGHT
60	2	914010P	5/8UNC HEX STOVER NUT
61	1	470117	COTTER PIN 3/16 1 3/4 SQ CUT
62	3	342917	TREAD ADJ PLATE, STEEL STS10
63	1	483018	1" EXTERNAL TOOTH LOCK WASHER

*NOTE: FOR TREAD ADJUST OPTION REPLACE ITEM 62 WITH THREE OF ITEM 51.

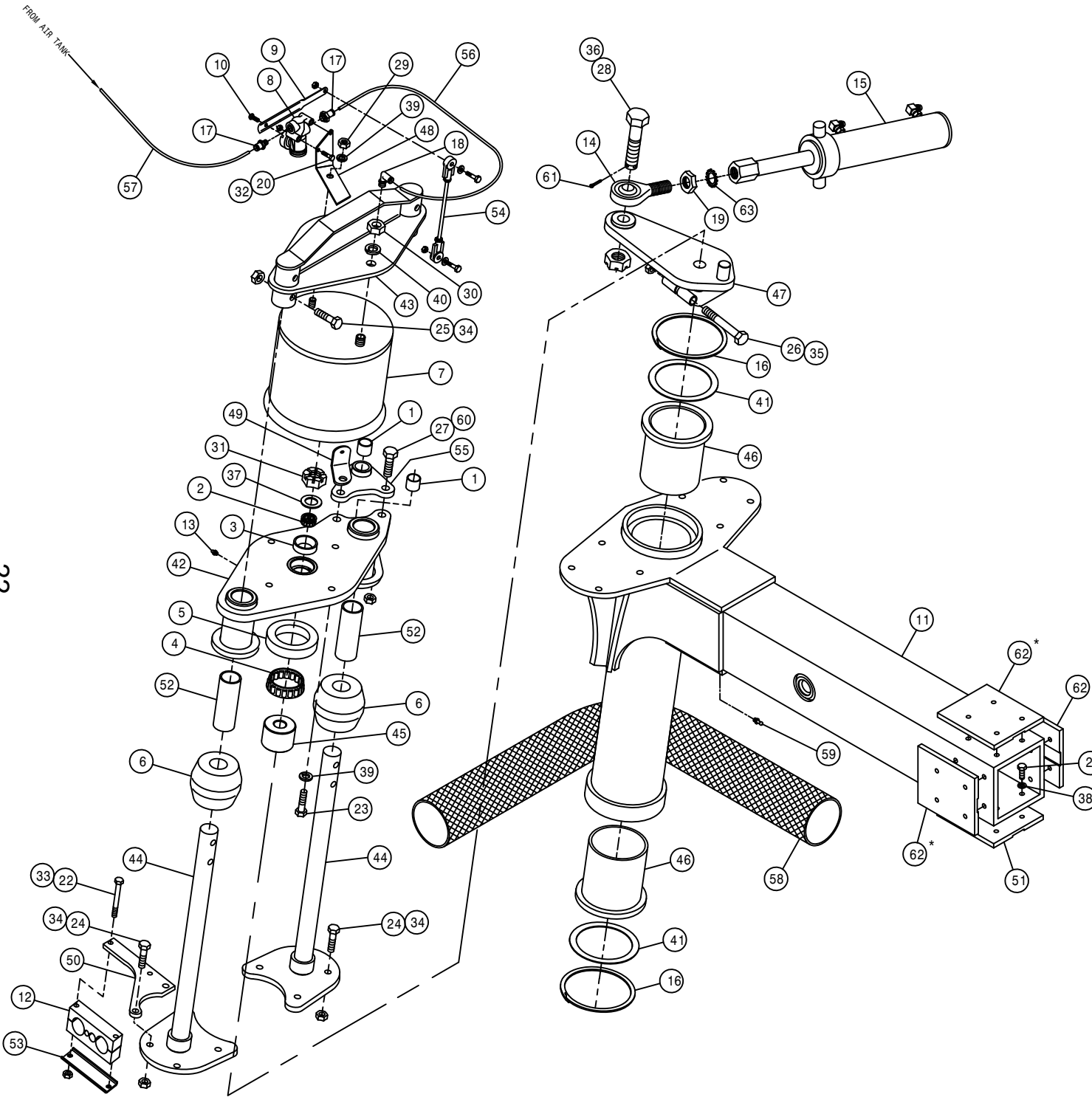

22

272022

LEFT FRONT INNER LEG ASSEMBLY

DET. QTY PART NO. DESCRIPTION

DET.	QTY	PART NO.	DESCRIPTION
1	1	359004	INNER LEG WLD, 72" STS12 00
2	1	470117	COTTER PIN 3/16 1 3/4 SQ CUT
3	1	470305	HOSE CLAMP, 4-HOLE
4	2	473838	20MM-1.5 X 40MM HEX BOLT 8.8
5	2	473839	20MM FLAT WASHER
6	17	473840	16MM-2.00 X 40MM HEX BOLT 8.8
7	17	473841	16MM LOCK WASHER
8	1	606978	SUND HYD MOTOR
9	1	610711	TORQ HUB, 22:1 CW12
10	2	618652	1" SPLIT FLANGE KIT
11	2	618676	O-RING FOR 1" SPL FLG 618652
12	10	824055	22MM-1.50 FLANGED WHEEL NUT
13	2	900138	3/8UNC X 3 1/2 HEX BOLT
14	4	900264	1/2UNC X 1 1/4 HEX BOLT
15	4	900265	1/2UNC X 1 1/2 HEX BOLT
16	2	914004	3/8UNC HEX STOVER NUT
17	8	914008	1/2UNC HEX STOVER NUT
18	1	359106	LH WHL MTR SHIELD, STS10
19	2	359102	WHL MTR SHIELD BRACE
20	1	359097	LH LWR LEG HYD HOSE MT WLD
21	1	359094	HYD TUBE CLAMP KEEPER, 5.75
22	1	470312	SIDEWINDER SLEEVE, 14.00 X 68"
23	1	606018	O-RING, WHL MTR 606978/606981
24	1	618327	3/4MJIC-7/8MOR ADPTR
25	1	606033	SHIFT SOLENOID GUARD KIT

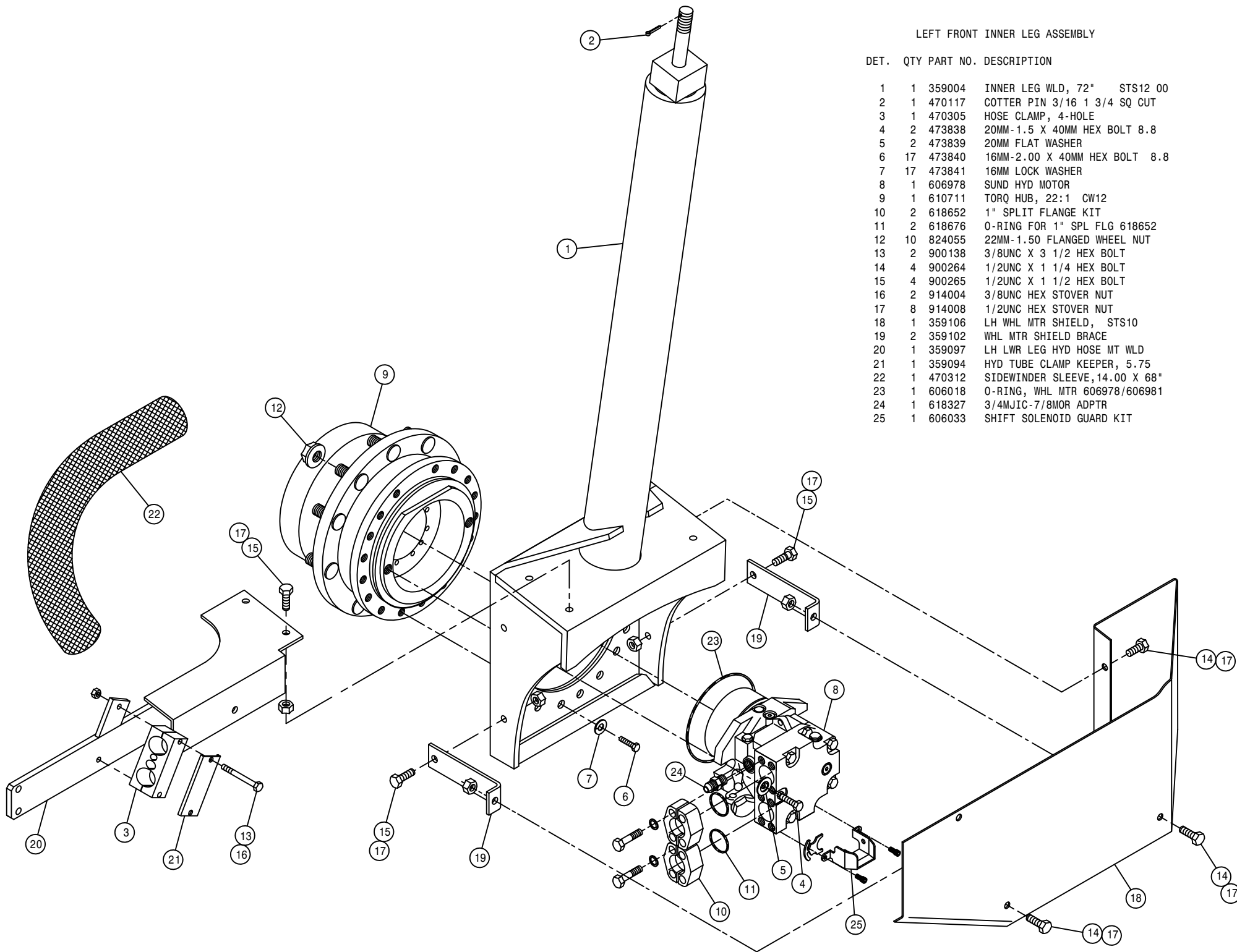

RIGHT REAR OUTER LEG ASSEMBLY

DET. QTY PART NO. DESCRIPTION

DET.	QTY	PART NO.	DESCRIPTION
1	2	121029	JOURNAL BRG, 1.00 ID X 1.00 LG
2	1	125051	BRG CONE, 1.00 ID W/FACE SEAL
3	1	125050	BRG CUP FOR 125050
4	1	125052	BRG CONE, 2.687 ID W/FACE SEAL
5	1	125053	BRG CUP FOR 125052
6	2	311058	RUBBER SPRING
7	1	311066	AIRIDE SPRING, STS12
8	1	311067	HEIGHT CONTROL AIR VALVE
9	1	311069	7.00 LEVER, CTRL AIR VLV 311067
10	1	311070	LEVER SCREW, CTRL AIR VLV311067
11	1	359005	OUTER LEG WLD, 72" STS12 00
12	1	470305	HOSE CLAMP, 4-HOLE
13	1	471005	1/4 28 X 1/2 GREASE ZERK
14	1	359089	TIE ROD STUD WLD
15	1	359086	REAR TIE ROD SHAFT WLD
16	2	629536	RETAINING RING, 6.00 INT SPIRAL
17	2	711036	1/8MNPT-1/4 NYL TUBE FTG
18	1	711040	1/4MNPT-1/4 NYL TUBE LBO
19	1	749322	STEERING TUBE CLAMP & BOLT ASSY
20	2	900006	1/4UNC X 1 3/4 HEX BOLT
21	16	900129	3/8UNC X 1" HEX BOLT
22	2	900138	3/8UNC X 3 1/2 HEX BOLT
23	4	900265	1/2UNC X 1 1/2 HEX BOLT
24	8	900267	1/2UNC X 2" HEX BOLT
25	4	900269	1/2UNC X 2 3/4 HEX BOLT
26	1	900343	5/8UNC X 4 1/2 HEX BOLT
27	2	900352P	5/8UNC X 2 1/4 HEX BOLT
28	1	359085	STEERING ARM BOLT, 1"-8THD STS
29	1	910008	1/2UNC HEX NUT
30	1	910013	3/4UNF HEX NUT
31	1	910021	1" -14 SLOT JAM NUT
32	2	914000	1/4UNC HEX STOVER NUT
33	2	914004	3/8UNC HEX STOVER NUT
34	12	914008	1/2UNC HEX STOVER NUT
35	1	914010	5/8UNC HEX STOVER NUT
36	1	910020	1" UNC HEX SLOTTED NUT
37	1	920008	1" SAE FLAT WASHER
38	16	920502	3/8 LOCK WASHER
39	5	920504	1/2 LOCK WASHER
40	1	920506	3/4 LOCK WASHER
41	2	359084	WASH, 14GA X 4.75ID X 5.87500
42	1	359057	RH AIR BAG LOWER PLT WLD
43	1	359052	AIR BAG TOWER TOP MT WLD
44	2	359077	NITRO TOWER SHAFT WLD STS
45	1	359082	STEERING ARM BRG SPACER
46	2	121100	LEG SLEEVE BEARING, ORKOT
47	1	359070	RH STEERING ARM WLD
48	1	359049	RH LEG AIR VALVE MT
49	1	359051	LWR AIR VALVE ARM MT
50	1	359081	UPPER LEG HOSE MT PLT
51	1	342719	TRD ADJ BRONZE BEARING, TAPPED
52	2	121105	LEG TOWER SLIDE BEARING, ORKOT
53	1	359094	HYD TUBE CLAMP KEEPER, 5.75
54	1	359095	LEG HEIGHT CTRL LINKAGE, STS12
55	1	359068	UPPER TRUNION MT PLT WLD
56	1	601473	HOSE, 1/4 X 22 AIR
57	1	601477	HOSE, 1/4 X 160 AIR
58	1	359092	RH SENSOR REFLECTOR
59	1	470311	SIDEWINDER SLEEVE, 14.00 X 60"
60	1	342856	TREAD SENSOR MT
61	1	293637	SENSOR W/SHROUD ASSY (SERV)
62	2	900064	5/16UNC X 3/4 HEX BOLT
63	2	914002	5/16UNC HEX STOVER NUT
64	1	471021	GREASE ZERK 1/8 NPT STRAIGHT
65	2	914010P	5/8UNC HEX STOVER NUT
66	1	470117	COTTER PIN 3/16 1 3/4 SQ CUT
67	3	342917	TREAD ADJ PLATE, STEEL STS10

*NOTE: FOR TREAD ADJUST OPTION REPLACE ITEM 67 WITH THREE OF ITEM 51.

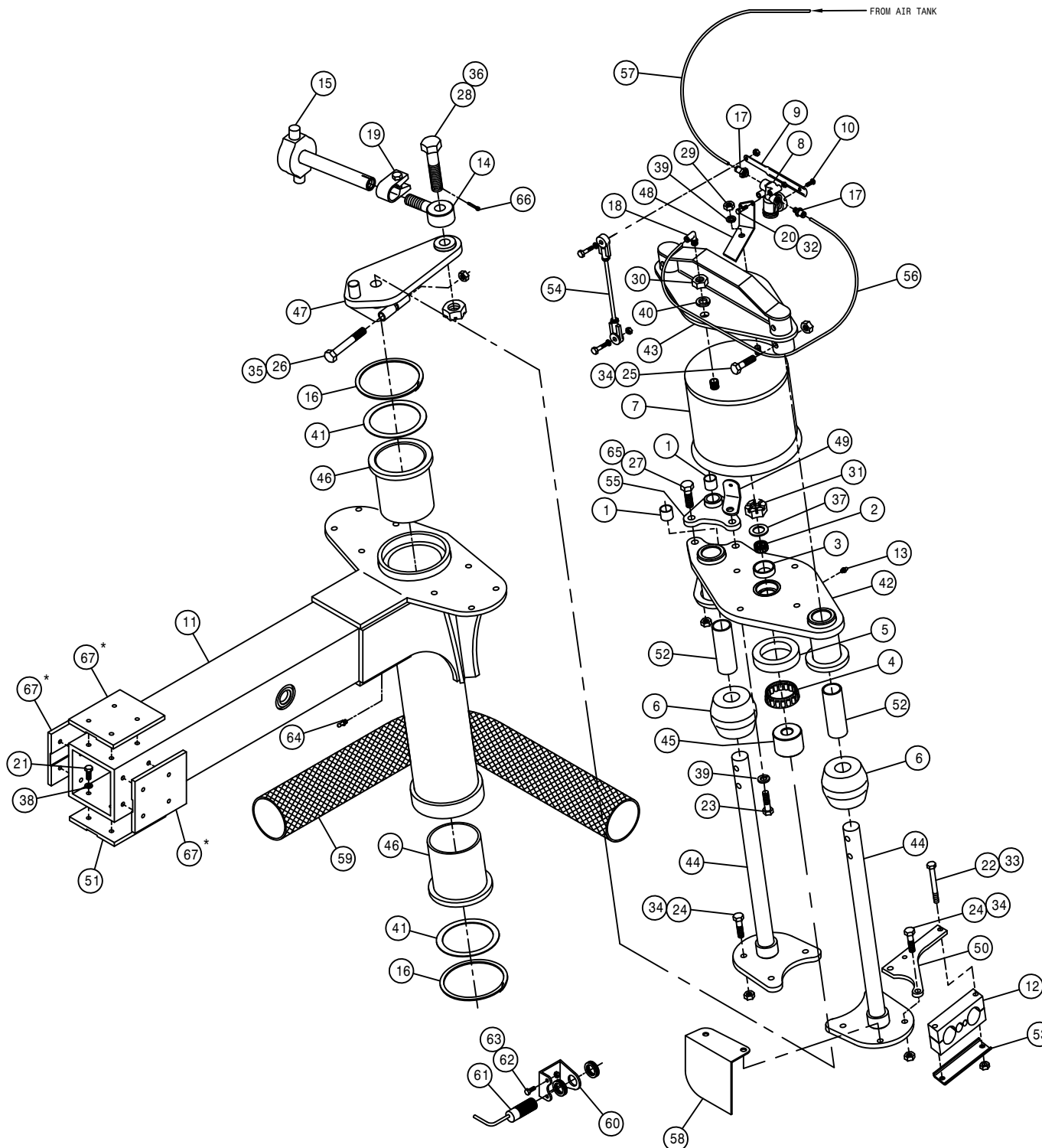

RIGHT REAR INNER LEG ASSEMBLY

DET. QTY PART NO. DESCRIPTION

1	1	359004	INNER LEG WLD, 72" STS12 00
2	1	470117	COTTER PIN 3/16 1 3/4 SQ CUT
3	1	470305	HOSE CLAMP, 4-HOLE
4	2	473838	20MM-1.5 X 40MM HEX BOLT 8.8
5	2	473839	20MM FLAT WASHER
6	17	473840	16MM-2.00 X 40MM HEX BOLT 8.8
7	17	473841	16MM LOCK WASHER
8	1	606978	SUND HYD MOTOR
9	1	610714	TORQ HUB, 27:1 CW12
10	1	618666	7/16MJIC-M12X1.5MOR ADPTR
11	2	618652	1" SPLIT FLANGE KIT
12	2	618676	O-RING FOR 1" SPL FLG 618652
13	10	824055	22MM-1.50 FLANGED WHEEL NUT
14	2	900138	3/8UNC X 3 1/2 HEX BOLT
15	4	900264	1/2UNC X 1 1/4 HEX BOLT
16	4	900265	1/2UNC X 1 1/2 HEX BOLT
17	2	914004	3/8UNC HEX STOVER NUT
18	8	914008	1/2UNC HEX STOVER NUT
19	1	359105	RH WHL MTR SHIELD, STS10
20	2	359102	WHL MTR SHIELD BRACE
21	1	359096	RH LWR LEG HYD HOSE MT WLD
22	1	359094	HYD TUBE CLAMP KEEPER, 5.75
23	1	470312	SIDEWINDER SLEEVE, 14.00 X 68"
24	1	606018	O-RING, WHL MTR 606978/606981
25	1	618327	3/4MJIC-7/8MOR ADPTR

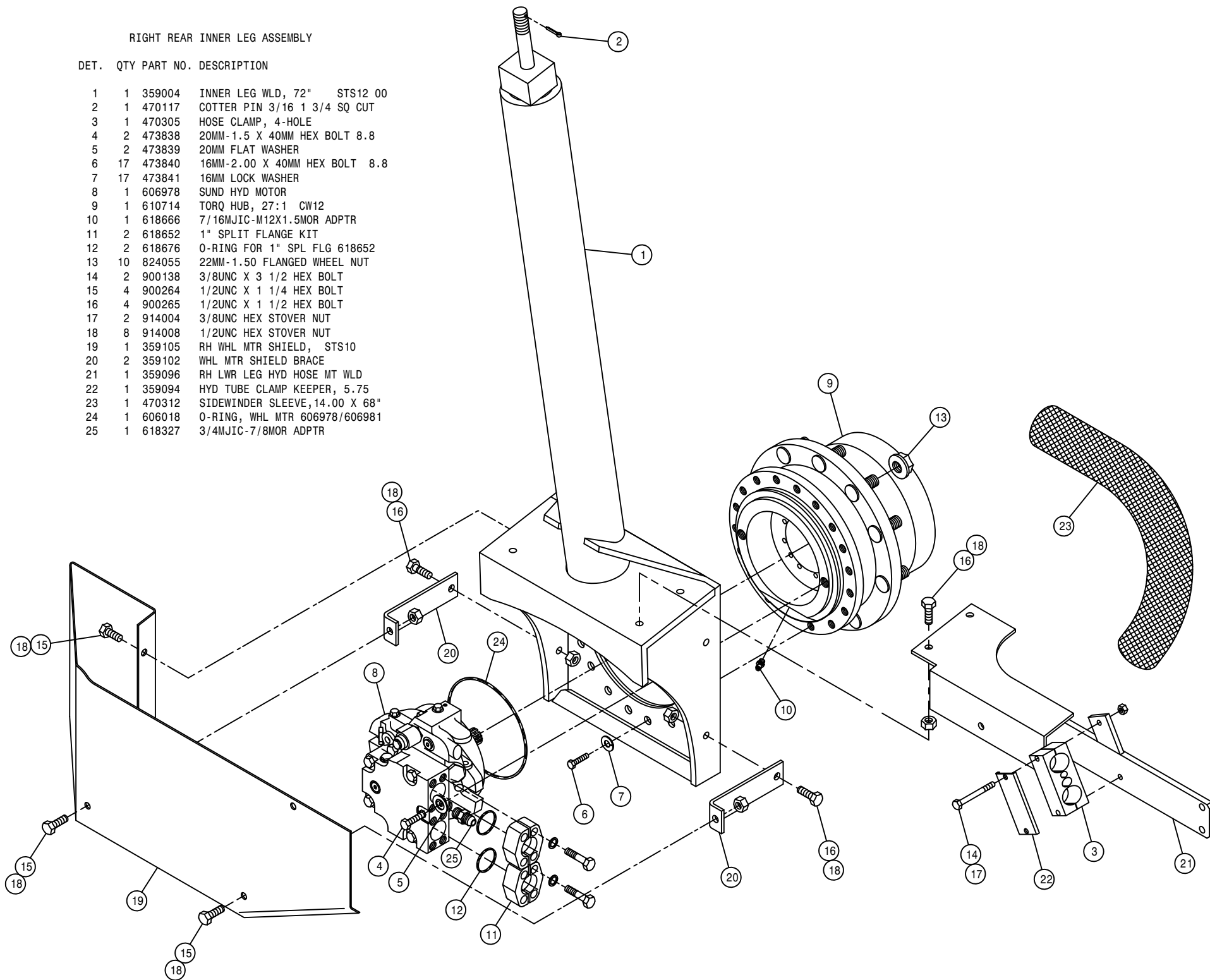

LEFT REAR OUTER LEG ASSEMBLY

DET.	QTY	PART NO.	DESCRIPTION
1	2	121029	JOURNAL BRG, 1.00 ID X 1.00 LG
2	1	125050	BRG CONE, 1.00 ID W/FACE SEAL
3	1	125051	BRG CUP FOR 125050
4	1	125052	BRG CONE, 2.687 ID W/FACE SEAL
5	1	125053	BRG CUP FOR 125052
6	2	311058	RUBBER SPRING
7	1	311066	AIRIDE SPRING, STS12
8	1	311067	HEIGHT CONTROL AIR VALVE
9	1	311069	7.00 LEVER, CTRL AIR VLV 311067
10	1	311070	LEVER SCREW, CTRL AIR VLV311067
11	1	359005	OUTER LEG WLD, 72" STS12 00
12	1	470305	HOSE CLAMP, 4-HOLE
13	1	471005	1/4 28 X 1/2 GREASE ZERK
14	1	359089	TIE ROD STUD WLD
15	1	359086	REAR TIE ROD SHAFT WLD
16	2	629536	RETAINING RING, 6.00 INT SPIRAL
17	2	711036	1/8MNPT-1/4 NYL TUBE FTG
18	1	711040	1/4MNPT-1/4 NYL TUBE LBO
19	1	749322	STEERING TUBE CLAMP & BOLT ASSY
20	2	900006	1/4UNC X 1 3/4 HEX BOLT
21	16	900129	3/8UNC X 1" HEX BOLT
22	2	900138	3/8UNC X 3 1/2 HEX BOLT
23	4	900265	1/2UNC X 1 1/2 HEX BOLT
24	8	900267	1/2UNC X 2" HEX BOLT
25	4	900269	1/2UNC X 2 3/4 HEX BOLT
26	1	900343	5/8UNC X 4 1/2 HEX BOLT
27	2	900352P	5/8UNC X 2 1/4 HEX BOLT
28	1	359085	STEERING ARM BOLT, 1"-8THD STS
29	1	910008	1/2UNC HEX NUT
30	1	910013	3/4UNF HEX NUT
31	1	910021	1" - 14 SLOT JAM NUT
32	2	914000	1/4UNC HEX STOVER NUT
33	2	914004	3/8UNC HEX STOVER NUT
34	12	914008	1/2UNC HEX STOVER NUT
35	1	914010	5/8UNC HEX STOVER NUT
36	1	910020	1" UNC HEX SLOTTED NUT
37	1	920008	1" SAE FLAT WASHER
38	16	920502	3/8 LOCK WASHER
39	5	920504	1/2 LOCK WASHER
40	1	920506	3/4 LOCK WASHER
41	2	359084	WASH, 14GA X 4.75ID X 5.875OD
42	1	359058	LH AIR BAG LOWER PLT WLD
43	1	359052	AIR BAG TOWER TOP MT WLD
44	2	359077	NITRO TOWER SHAFT WLD STS
45	1	359082	STEERING ARM BRG SPACER
46	2	121100	LEG SLEEVE BEARING, ORKOT
47	1	359071	LH STEERING ARM WLD
48	1	359050	LH LEG AIR VALVE MT
49	1	359051	LWR AIR VALVE ARM MT
50	1	359081	UPPER LEG HOSE MT PLT
51	1	342719	TRD ADJ BRONZE BEARING, TAPPED
52	2	121105	LEG TOWER SLIDE BEARING, ORKOT
53	1	359094	HYD TUBE CLAMP KEEPER, 5.75
54	1	359095	LEG HEIGHT CTRL LINKAGE, STS12
55	1	359068	UPPER TRUNION MT PLT WLD
56	1	601473	HOSE, 1/4 X 22 AIR
57	1	601476	HOSE, 1/4 X 120 AIR
58	1	359093	LH SENSOR REFLECTOR
59	1	470311	SIDEWINDER SLEEVE, 14.00 X 60"
60	1	342856	TREAD SENSOR MT
61	1	293637	SENSOR W/SHROUD ASSY (SERV)
62	2	900064	5/16UNC X 3/4 HEX BOLT
63	2	914002	5/16UNC HEX STOVER NUT
64	1	471021	GREASE ZERK 1/8 NPT STRAIGHT
65	2	914010P	5/8UNC HEX STOVER NUT
66	1	470117	COTTER PIN 3/16 1 3/4 SQ CUT
67	3	342917	TREAD ADJ PLATE, STEEL STS10

*NOTE: FOR TREAD ADJUST OPTION REPLACE ITEM 67 WITH THREE OF ITEM 51.

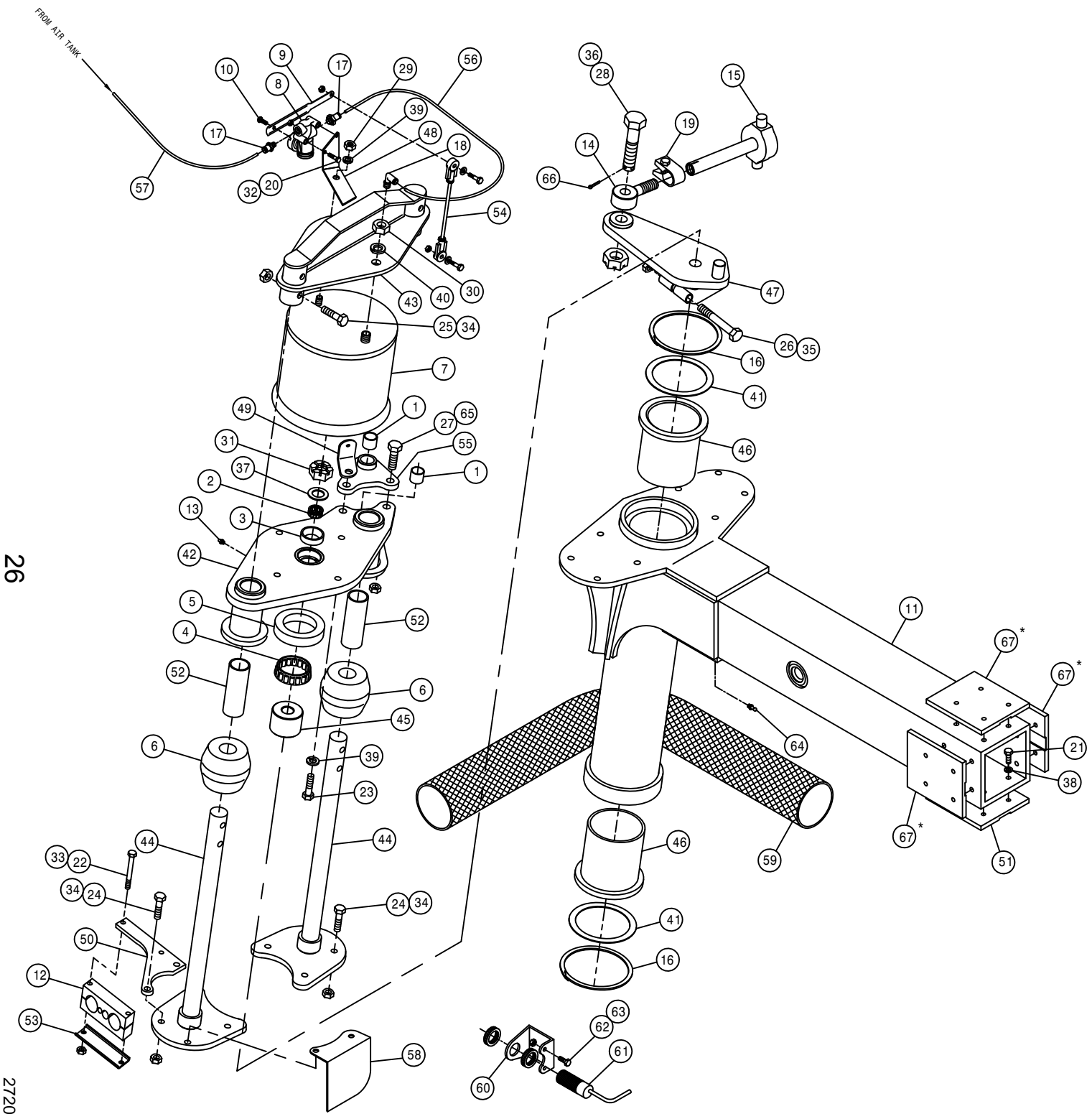

26

272026

LEFT REAR INNER LEG ASSEMBLY

DET. QTY PART NO. DESCRIPTION

1	1	359004	INNER LEG WLD, 72" STS12 00
2	1	470117	COTTER PIN 3/16 1 3/4 SQ CUT
3	1	470305	HOSE CLAMP, 4-HOLE
4	2	473838	20MM-1.5 X 40MM HEX BOLT 8.8
5	2	473839	20MM FLAT WASHER
6	17	473840	16MM-2.00 X 40MM HEX BOLT 8.8
7	17	473841	16MM LOCK WASHER
8	1	606993	SAUER HYD MOTOR W/DIV-2 SENSOR
9	1	610714	TORQ HUB, 27:1 CW12
10	1	618666	7/16MJIC-M12X1.5MOR ADPTR
11	2	618652	1" SPLIT FLANGE KIT
12	2	618676	O-RING FOR 1" SPL FLG 618652
13	10	824055	22MM-1.50 FLANGED WHEEL NUT
14	2	900138	3/8UNC X 3 1/2 HEX BOLT
15	4	900264	1/2UNC X 1 1/4 HEX BOLT
16	4	900265	1/2UNC X 1 1/2 HEX BOLT
17	2	914004	3/8UNC HEX STOVER NUT
18	8	914008	1/2UNC HEX STOVER NUT
19	1	359106	LH WHL MTR SHIELD, STS10
20	2	359102	WHL MTR SHIELD BRACE
21	1	359097	LH LWR LEG HYD HOSE MT WLD
22	1	359094	HYD TUBE CLAMP KEEPER, 5.75
23	1	606959	SPEED SENSOR, DIV-2, MTR 606993
24	1	470312	SIDEWINDER SLEEVE, 14.00 X 68"
25	1	606018	O-RING, WHL MTR 606978/606981
26	1	618327	3/4MJIC-7/8MOR ADPTR
27	1	606033	SHIFT SOLENOID GUARD KIT

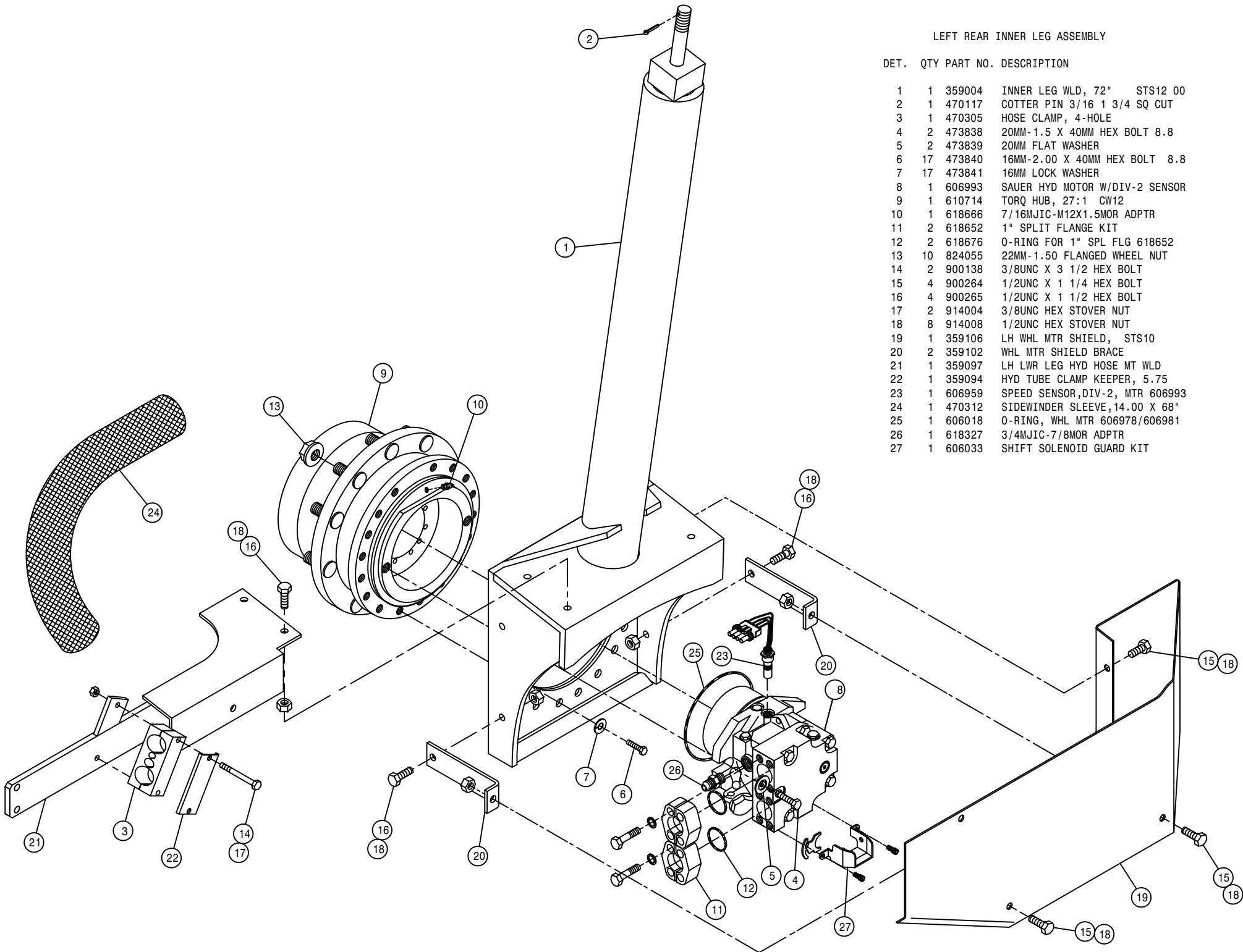

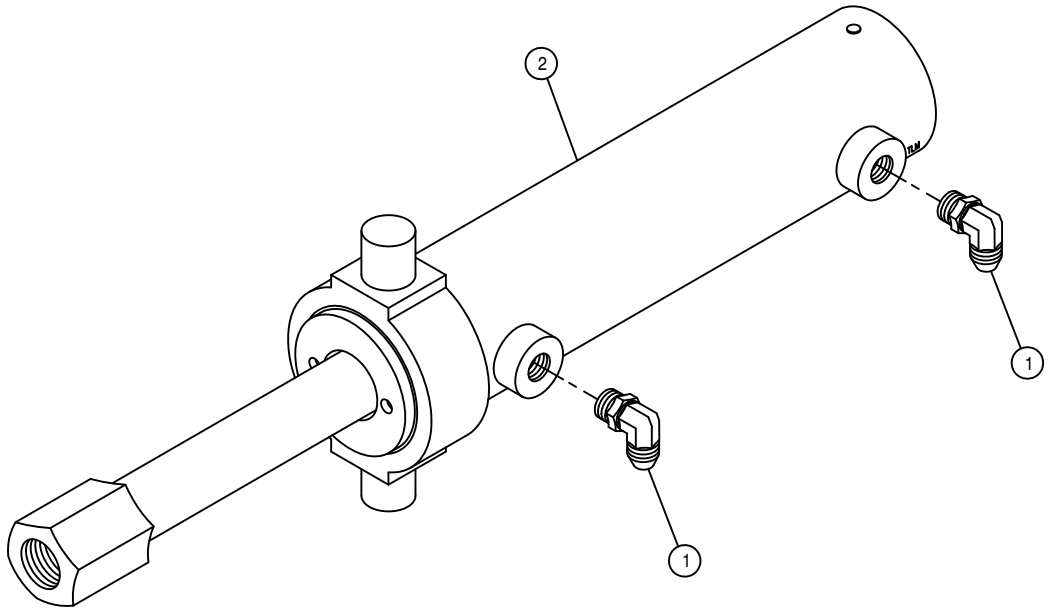

STEERING CYLINDER ASSEMBLY

DET.	QTY	PART NO.	DESCRIPTION
	1	2	618249 3/4MJIC-90-9/16MOR LBO
	2	1	621550 STEERING CYL,2.50 X 8.81 STS
	NS	1	621551 REPAIR KIT,HYD CYL,STRG 621550

NOTE: 1. 621063 - STEERING CYLINDER ASSEMBLY WITH FITTINGS

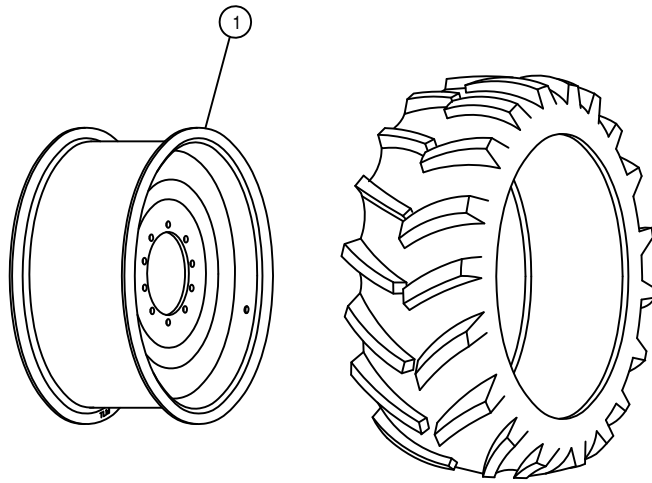

580/70 R38 RADIAL TIRE

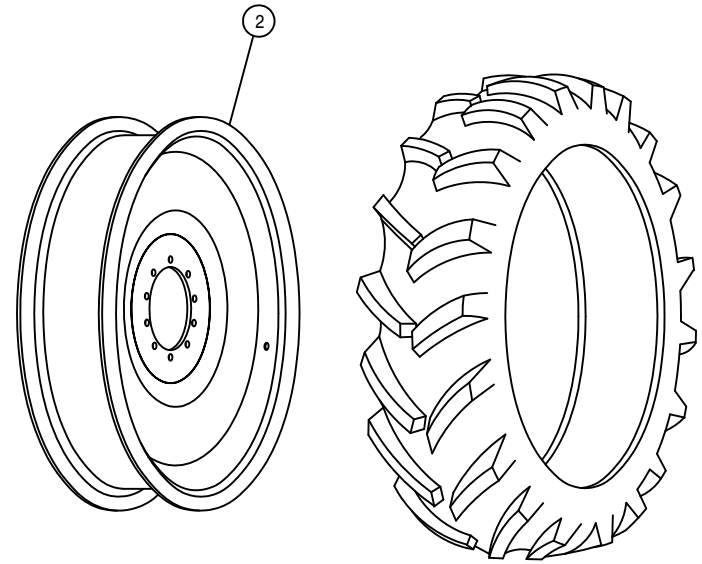

380/85 R46 RADIAL TIRE

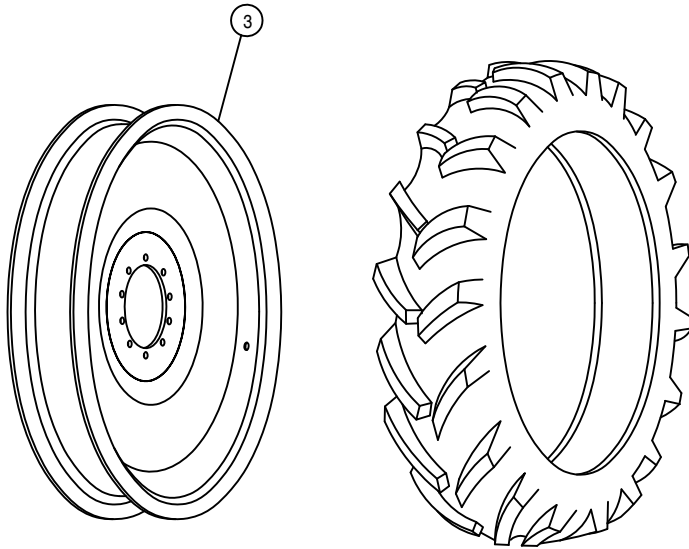

320/90 R50 RADIAL TIRE

TIRE AND RIM ASSEMBLY

DET.	QTY	PART NO.	DESCRIPTION	
1	1	821055	RIM WLD, 38 X W18A	STS12
2	1	821054	RIM WLD, 46 X W13A	STS12
3	1	821056	RIM WLD,50 X 10 TITAN	

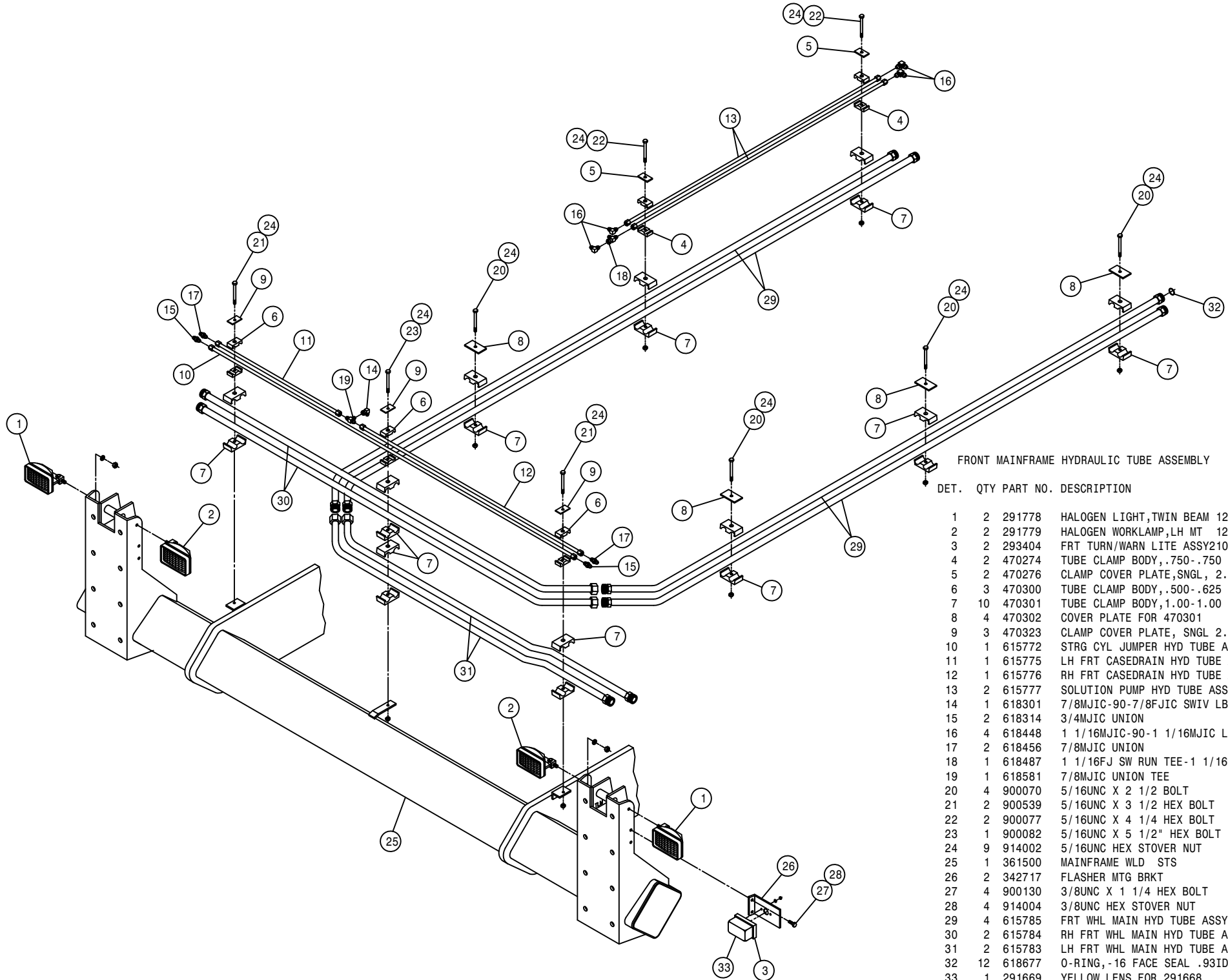

FRONT MAINFRAME HYDRAULIC TUBE ASSEMBLY

DET.	QTY	PART NO.	DESCRIPTION
1	2	291778	HALOGEN LIGHT, TWIN BEAM 12V55W
2	2	291779	HALOGEN WORKLAMP, LH MT 12V55W
3	2	293404	FRT TURN/WARN LITE ASSY 2100 98
4	2	470274	TUBE CLAMP BODY, .750-.750
5	2	470276	CLAMP COVER PLATE, SNGL, 2.55LG
6	3	470300	TUBE CLAMP BODY, .500-.625
7	10	470301	TUBE CLAMP BODY, 1.00-1.00
8	4	470302	COVER PLATE FOR 470301
9	3	470323	CLAMP COVER PLATE, SNGL 2.04LG
10	1	615772	STRG CYL JUMPER HYD TUBE ASSY
11	1	615775	LH FRT CASE DRAIN HYD TUBE ASSY
12	1	615776	RH FRT CASE DRAIN HYD TUBE ASSY
13	2	615777	SOLUTION PUMP HYD TUBE ASSY
14	1	618301	7/8MJIC-90-7/8FJIC SWIV LBO
15	2	618314	3/4MJIC UNION
16	4	618448	1 1/16MJIC-90-1 1/16MJIC LBO
17	2	618456	7/8MJIC UNION
18	1	618487	1 1/16FJ SW RUN TEE-1 1/16MJ
19	1	618581	7/8MJIC UNION TEE
20	4	900070	5/16UNC X 2 1/2 BOLT
21	2	900539	5/16UNC X 3 1/2 HEX BOLT
22	2	900077	5/16UNC X 4 1/4 HEX BOLT
23	1	900082	5/16UNC X 5 1/2" HEX BOLT
24	9	914002	5/16UNC HEX STOVER NUT
25	1	361500	MAINFRAME WLD STS
26	2	342717	FLASHER MTG BRKT
27	4	900130	3/8UNC X 1 1/4 HEX BOLT
28	4	914004	3/8UNC HEX STOVER NUT
29	4	615785	FRT WHL MAIN HYD TUBE ASSY
30	2	615784	RH FRT WHL MAIN HYD TUBE ASSY
31	2	615783	LH FRT WHL MAIN HYD TUBE ASSY
32	12	618677	O-RING, -16 FACE SEAL .93ID 90D
33	1	291669	YELLOW LENS FOR 291668

00

30

272030

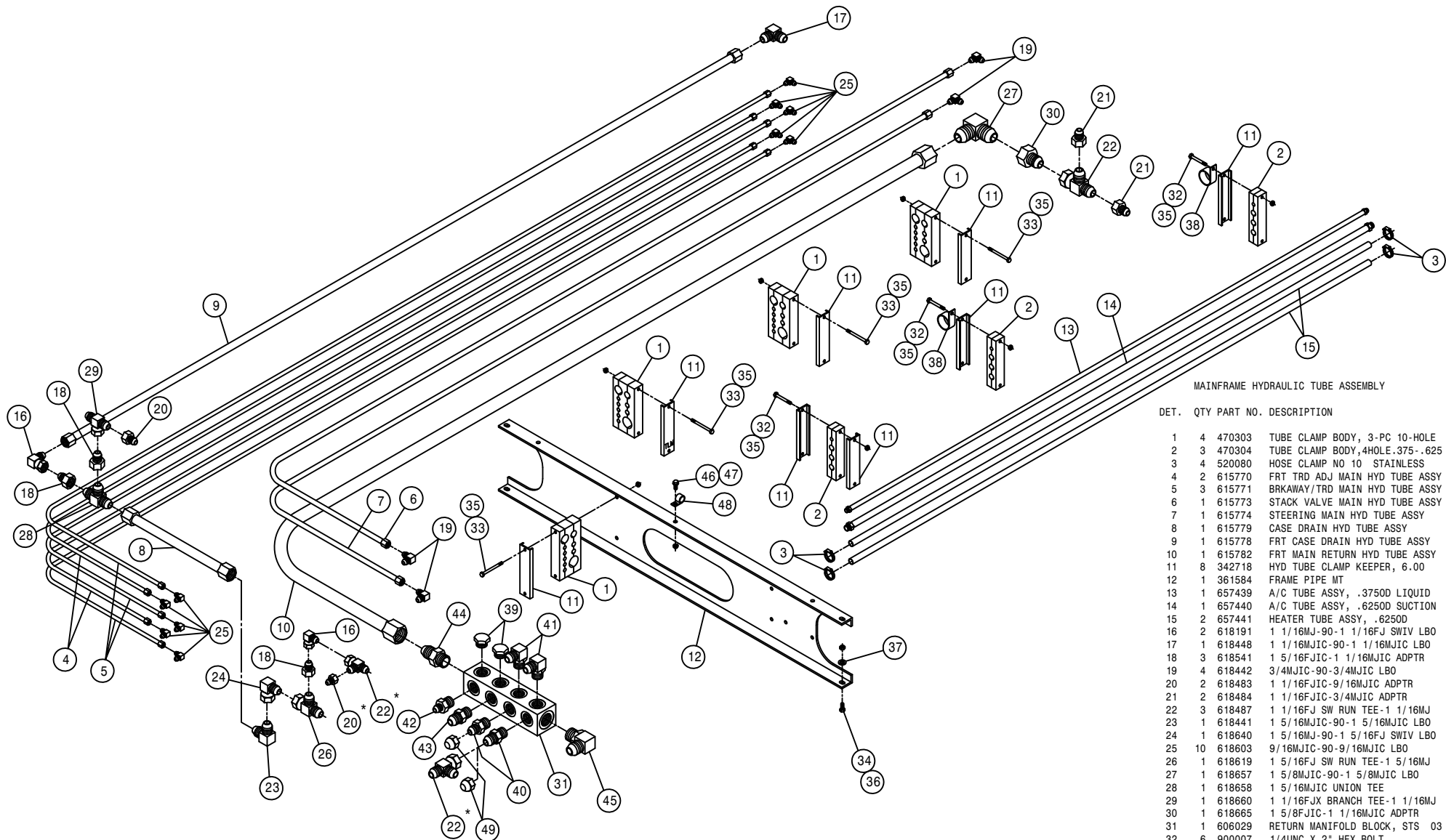

MAINFRAME HYDRAULIC TUBE ASSEMBLY

DET.	QTY	PART NO.	DESCRIPTION
1	4	470303	TUBE CLAMP BODY, 3-PC 10-HOLE
2	3	470304	TUBE CLAMP BODY, 4HOLE .375-.625
3	4	520080	HOSE CLAMP NO 10 STAINLESS
4	2	615770	FRT TRD ADJ MAIN HYD TUBE ASSY
5	3	615771	BRKAWAY/TRD MAIN HYD TUBE ASSY
6	1	615773	STACK VALVE MAIN HYD TUBE ASSY
7	1	615774	STEERING MAIN HYD TUBE ASSY
8	1	615779	CASE DRAIN HYD TUBE ASSY
9	1	615778	FRT CASE DRAIN HYD TUBE ASSY
10	1	615782	FRT MAIN RETURN HYD TUBE ASSY
11	8	342718	HYD TUBE CLAMP KEEPER, 6.00
12	1	361584	FRAME PIPE MT
13	1	657439	A/C TUBE ASSY, .37500 LIQUID
14	1	657440	A/C TUBE ASSY, .62500 SUCTION
15	2	657441	HEATER TUBE ASSY, .62500
16	2	618191	1 1/16MJ-90-1 1/16FJ SWIV LBO
17	1	618448	1 1/16MJIC-90-1 1/16MJIC LBO
18	3	618541	1 5/16FJIC-1 1/16MJIC ADPTR
19	4	618442	3/4MJIC-90-3/4MJIC LBO
20	2	618483	1 1/16FJIC-9/16MJIC ADPTR
21	2	618484	1 1/16FJIC-3/4MJIC ADPTR
22	3	618487	1 1/16FJ SW RUN TEE-1 1/16MJ
23	1	618441	1 5/16MJIC-90-1 5/16MJIC LBO
24	1	618640	1 5/16MJ-90-1 5/16FJ SWIV LBO
25	10	618603	9/16MJIC-90-9/16MJIC LBO
26	1	618619	1 5/16FJ SW RUN TEE-1 5/16MJ
27	1	618657	1 5/8MJIC-90-1 5/8MJIC LBO
28	1	618658	1 5/16MJIC UNION TEE
29	1	618660	1 1/16FJX BRANCH TEE-1 1/16MJ
30	1	618665	1 5/8FJIC-1 1/16MJIC ADPTR
31	1	606029	RETURN MANIFOLD BLOCK, STS 03
32	6	900007	1/4UNC X 2" HEX BOLT
33	8	900014	1/4UNC X 4" HEX BOLT
34	4	900129	3/8UNC X 1" HEX BOLT
35	14	914000	1/4UNC HEX STOVER NUT
36	4	914004	3/8UNC HEX STOVER NUT
37	4	920002	3/8 SAE FLAT WASHER
38	2	520126	CUSH HOSE CLAMP 2IN X 5/8W
39	2	610186	1 1/16MOR PLUG
40	2	611127	1 1/16MJIC-1 1/16MOR ADPTR
41	2	618248	1 1/16MJIC-90-1 1/16MOR LBO
42	1	618344	9/16MJIC-1 1/16MOR ADPTR
43	1	618469	3/4MJIC-1 1/16MOR ADPTR
44	1	618471	1 5/8MJIC-1 5/16MOR ADPTR
45	1	618476	1 5/8MJIC-90-1 5/16MOR LBO
46	3	470118	1/4UNC X 3/4 FLANGE HEX BOLT
47	3	470121	1/4UNC HEX FLANGE LOCK NUT
48	3	520100	CUSH HOSE CLAMP, 1 1/2D X 1/2W
49	2	618533	1 1/16FJIC CAP NUT

NOTE: ITEMS MARKED WITH A (*) ARE USED WITH THE SIDE FILL OPTION AND PRESSURE WASHER OPTION.

TREAD ADJUST ASSEMBLY

DET.	QTY	PART NO.	DESCRIPTION
1	8	483018	1" EXTERNAL TOOTH LOCK WASHER
2	2	616070	04-451TC-04MJBH-06MOR-11.00H/A
3	2	616071	04-451TC-04MJBH-06MOR-13.00H/A
4	4	618525	7/16-20 BLKHD LOCKNUT
5	2	621552	TRD ADJ CYL, 3.00 X 16.00 STS
6	16	900129	3/8UNC X 1" HEX BOLT
7	8	900303	1/2UNF X 1 1/2 HEX BOLT
8	4	900391	3/4UNC X 1 1/2 FLT SOC CAP SCR
9	16	900395	1"UNC X 2 1/2 SOCKET CAP SCR
10	16	910101	1" UNC HEX JAM NUT
11	16	920002	3/8 SAE FLAT WASHER
12	16	920502	3/8 LOCK WASHER
13	12	920504	1/2 LOCK WASHER
14	1	361579	REAR TRD ADJ ACCESS PLT WLD
15	1	361576	FRT TREAD ADJ ACCESS PLT WLD
16	2	361581	TRD ADJ CYL PIVOT PIN, M/F
17	4	361583	TRD ADJ CYL SPACER, M/F
18	2	361582	TREAD ADJ CYL PIN, OUTER LEG
19	4	342719	TRD ADJ BRONZE BEARING, TAPPED
20	4	342721	TRD ADJ BRONZE BRG
21	4	342917	TREAD ADJ PLATE, STEEL STS10
22	2	361609	TRD ADJ ACCESS COVER, M/F STS10
23	4	900301	1/2UNF X 1" HEX BOLT
24	2	361621	120" TREAD LOCK WLD, STS10 03
25	2	900403	3/4UNC X 2" HEX BOLT
26	2	914012	3/4UNC HEX STOVER NUT

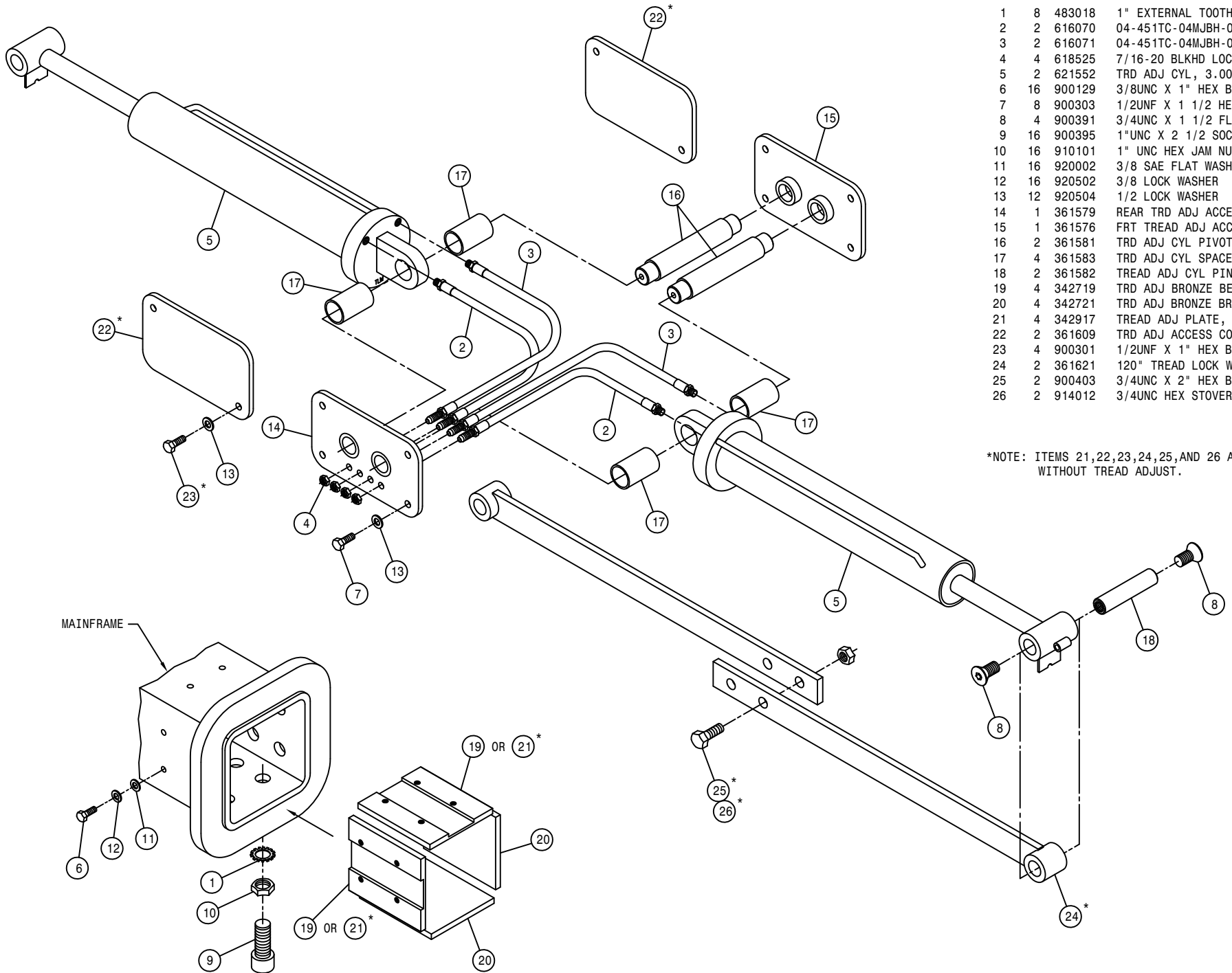

*NOTE: ITEMS 21,22,23,24,25,AND 26 ARE USED WITHOUT TREAD ADJUST.

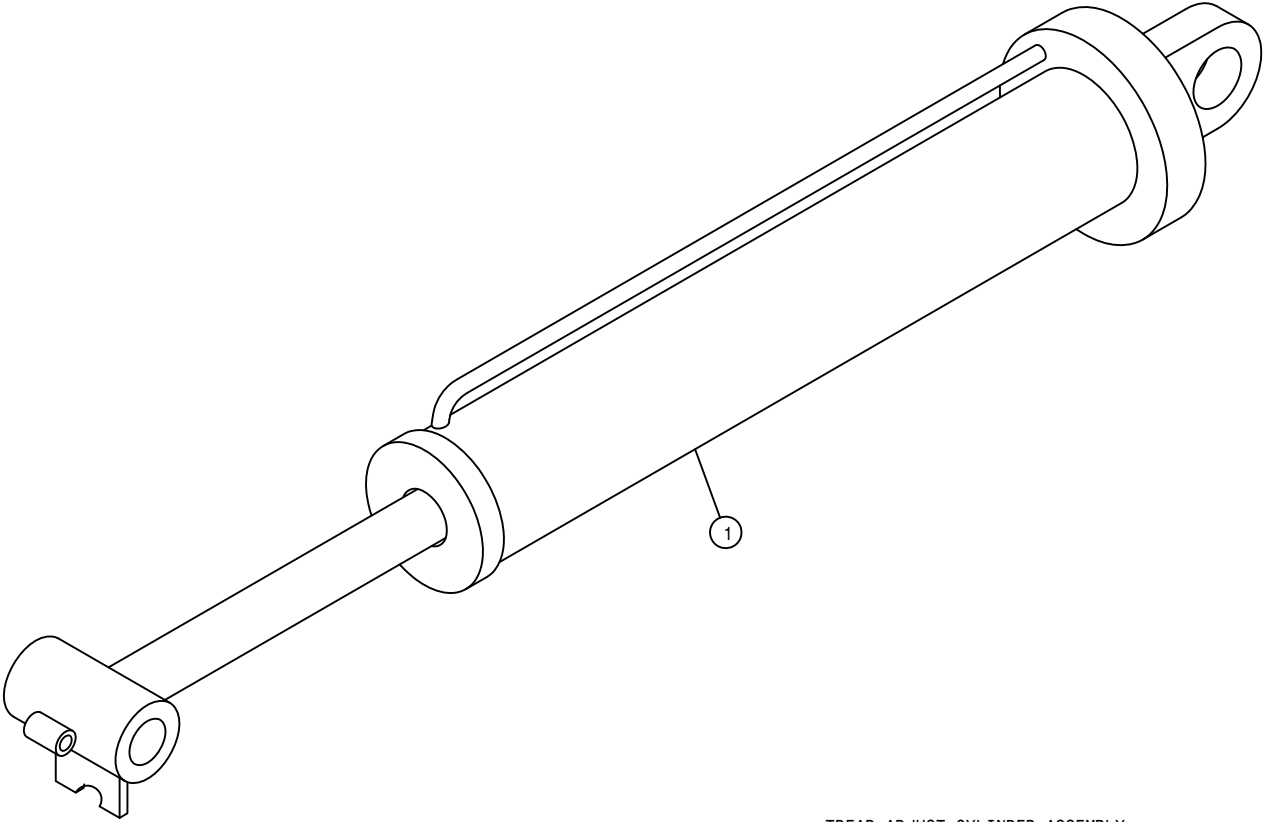

TREAD ADJUST CYLINDER ASSEMBLY

DET. QTY PART NO. DESCRIPTION

1	1	621552	TRD ADJ CYL, 3.00 X 16.00	STS
NS	1	621553	REPAIR KIT, HYD CYL 621552	

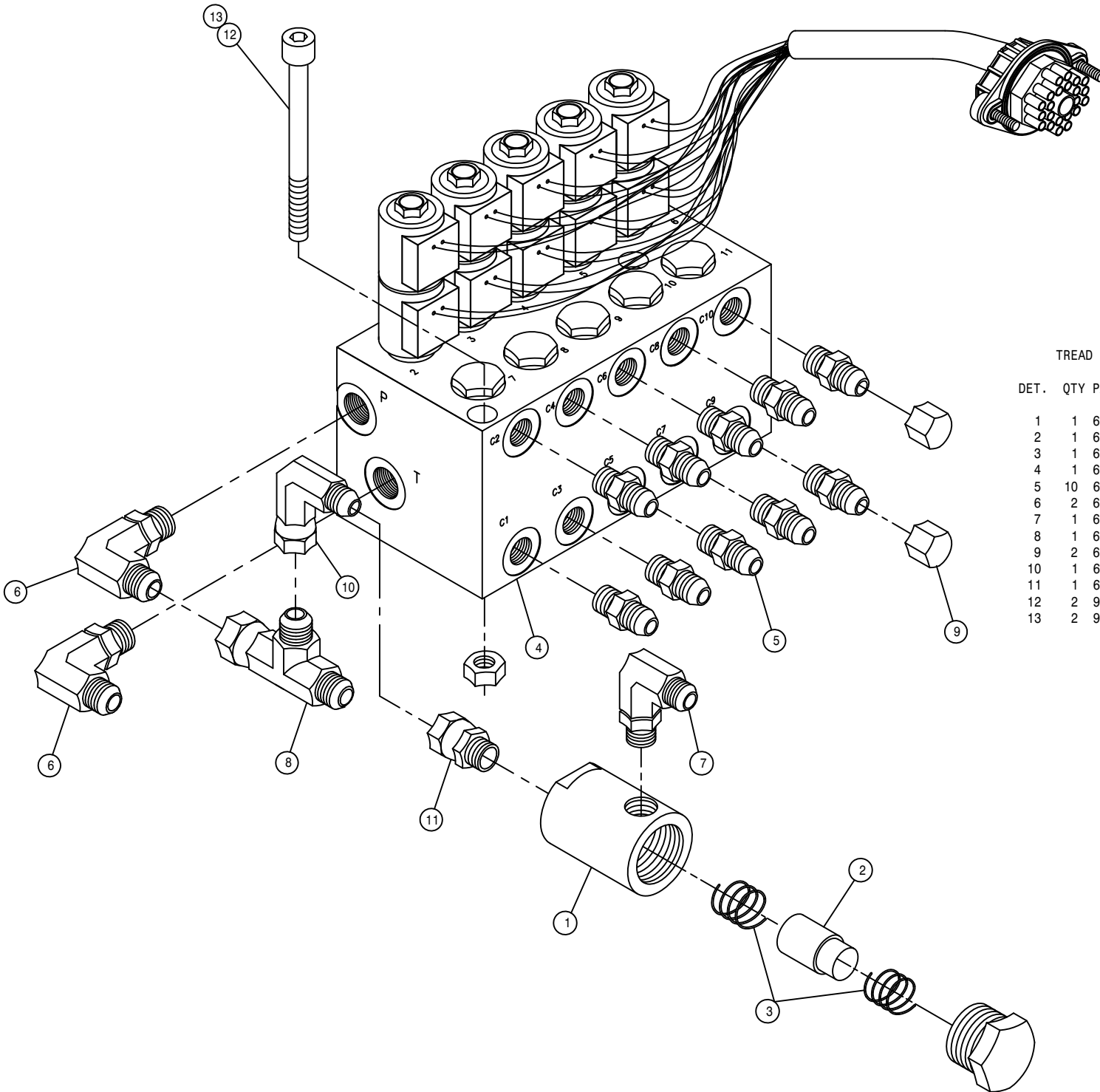

TREAD ADJUST HYD MANIFOLD ASSEMBLY

DET.	QTY	PART NO.	DESCRIPTION
1	1	605615	HYD FILTER, INLINE 25M 9/16FOR
2	1	605616	ELEMENT, 25M HYD FILTER 605615
3	1	605617	SPRING KIT, HYD FILTER 605615
4	1	606103	TREAD ADJ VLV, STS PWRSYS 03
5	10	618126	9/16MJIC-9-16MOR ADPTR
6	2	618241	3/4MJIC-90-3/4MOR LBO
7	1	618249	3/4MJIC-90-9/16MOR LBO
8	1	618451	3/4FJIC SW RUN TEE-3/4MJIC
9	2	618531	9/16FJIC CAP NUT
10	1	618609	3/4MJIC-90-3/4FJIC SWIV LBO
11	1	618692	3/4FJIC SWIV-9/16MOR ADPTR
12	2	900145	3/8UNC X 5 SOCKET HD CAP SCR
13	2	914004	3/8UNC HEX STOVER NUT

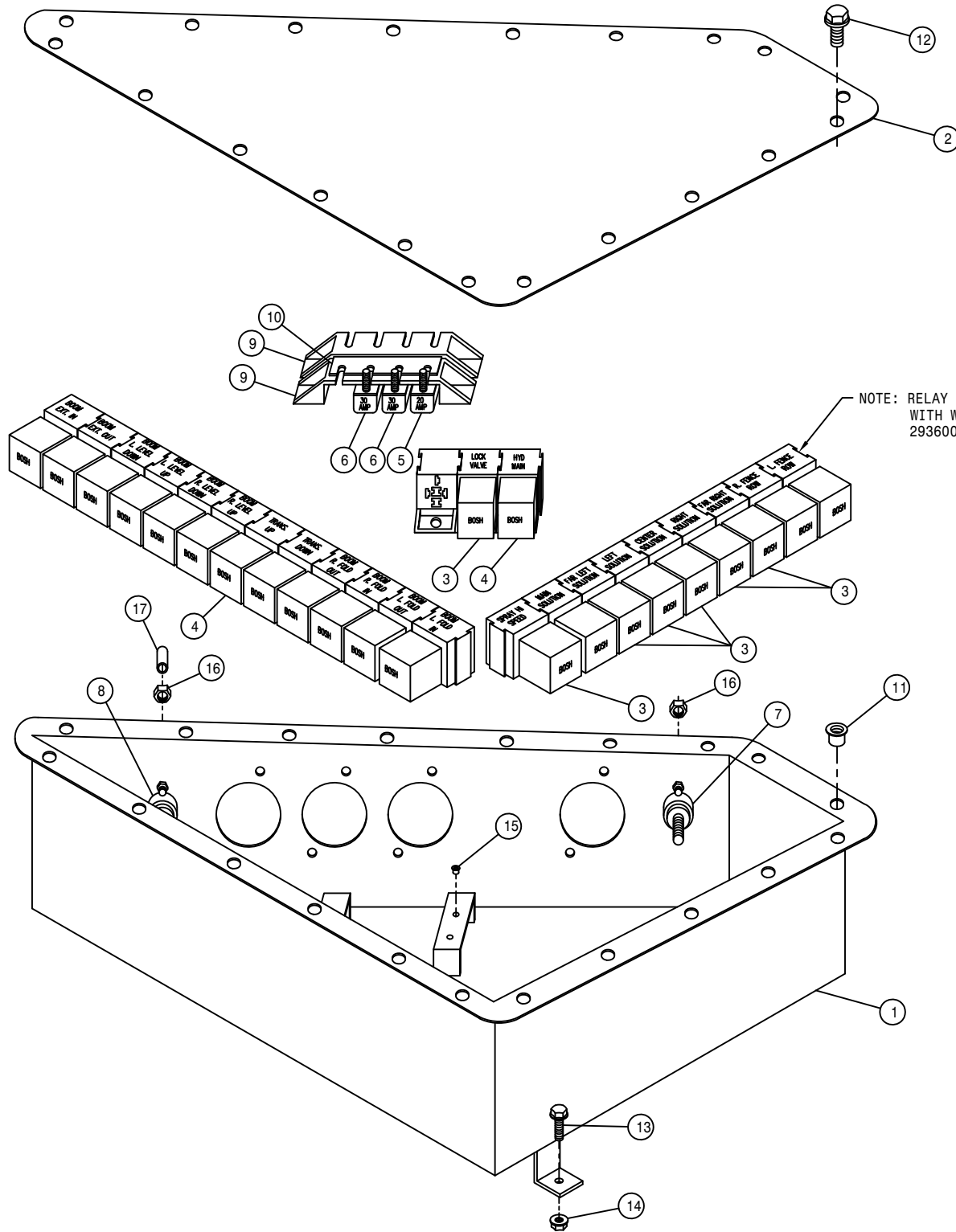

BOOM ELECTRICAL BOX ASSEMBLY

DET. QTY PART NO. DESCRIPTION

1	1	342830	BOOM ELECTRICAL BOX WLD
2	1	342837	BOOM ELECTRICAL BOX COVER
3	7	291752	RELAY, SPDT 12V 50A-NO 5-TERM
4	16	291751	RELAY, SPST 12V 40A-NO 5-TERM
5	1	291573	CIRCUIT BREAKER,20AMP W/O MT
6	2	291574	CIRCUIT BREAKER,30AMP W/O MT
7	1	291750	TERM BLOCK,RED,3/8-16 THRU
8	1	291749	TERM BLOCK,BLACK,3/8-16 THRU
9	2	291755	BREAKER MTG BRKT, 4-GANG NYLON
10	1	291756	BUS BAR,4-GANG FOR 291755
11	20	470086	1/4UNC NUTSERT .020-.100MATL
12	20	470122	1/4UNC X 1/2 FLANGE HEX BOLT
13	3	470118	1/4UNC X 3/4 FLANGE HEX BOLT
14	3	470121	1/4UNC HEX FLANGE LOCK NUT
15	14	470165	10-32 NUTSERT .020-.100 MATL
16	2	910004	3/8UNC HEX NUT
17	2	629764	CAPPLUGS CAP, .375 X 1.00 VINYL

NOTE: ALL RELAY BASES AND FUSE BLOCKS
COME WITH WIRE HARNESS
293626 - ENGINE BOX HARNESS

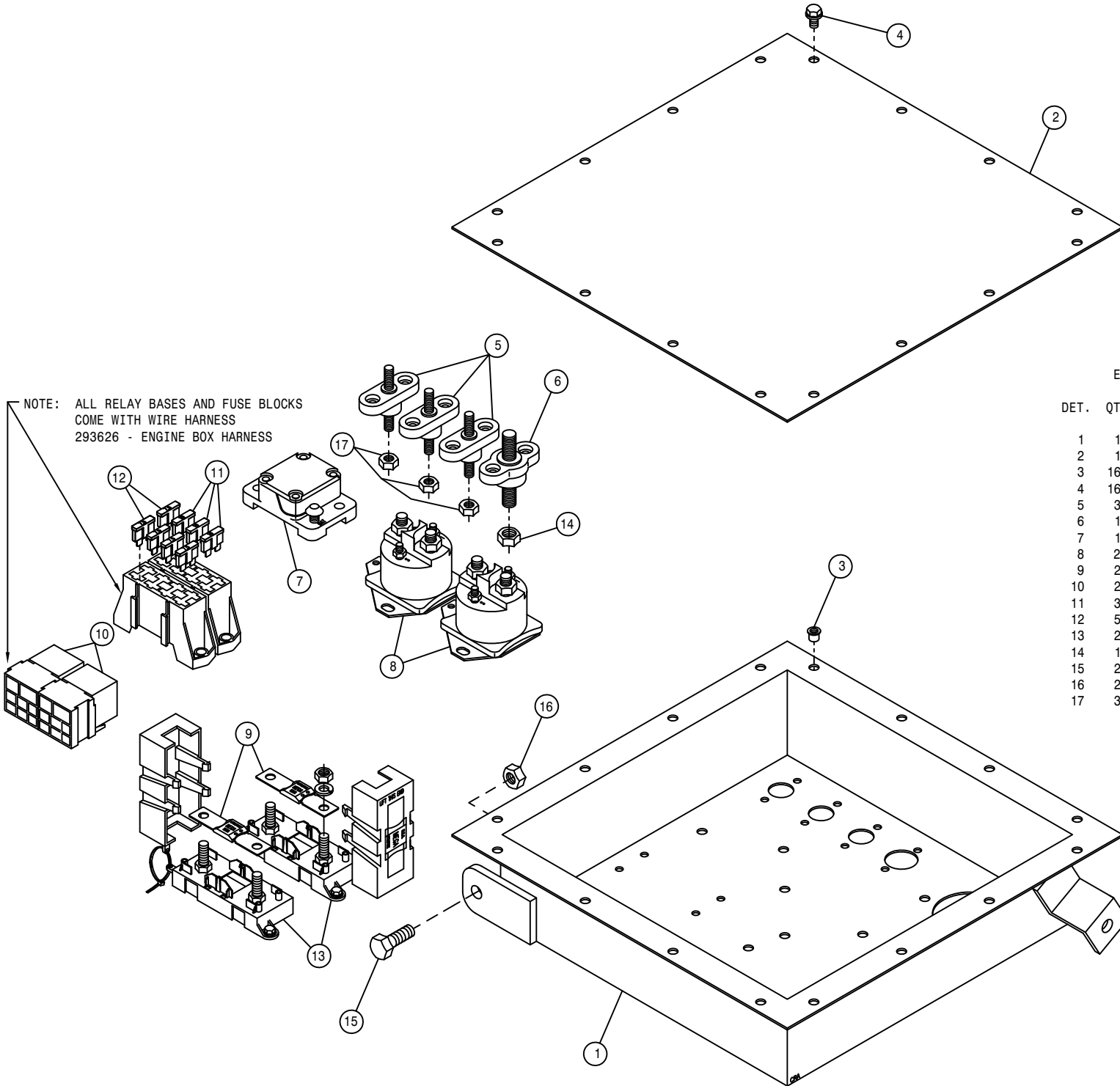

ENGINE ELECTRICAL BOX ASSEMBLY

DET.	QTY	PART NO.	DESCRIPTION
1	1	342851	ENG ELECTRICAL BOX WLD
2	1	342855	ENG ELECTRICAL BOX COVER
3	16	470086	1/4UNC NUTSERT .020-.100MATL
4	16	470122	1/4UNC X 1/2 FLANGE HEX BOLT
5	3	291748	TERM BLOCK, BLACK, 1/4-20 THRU
6	1	291750	TERM BLOCK, RED, 3/8-16 THRU
7	1	291815	CIRCUIT BREAKER, 100 AMP BUSS
8	2	291816	SOLENOID, STS 00
9	2	291813	FUSE, 125 AMP 32V DC
10	2	291751	RELAY, SPST 12V 40A-NO 5-TERM
11	3	291545	10 AMP FUSE, 1/4" BLADE ATO/ATC
12	5	291027	7.5 AMP FUSE, 1/4" BLADE ATO/ATC
13	2	291814	FUSE HOLDER, HIGH AMP
14	1	910004	3/8UNC HEX NUT
15	2	900129	3/8UNC X 1" HEX BOLT
16	2	914004	3/8UNC HEX STOVER NUT
17	3	470121	1/4UNC HEX FLANGE LOCK NUT

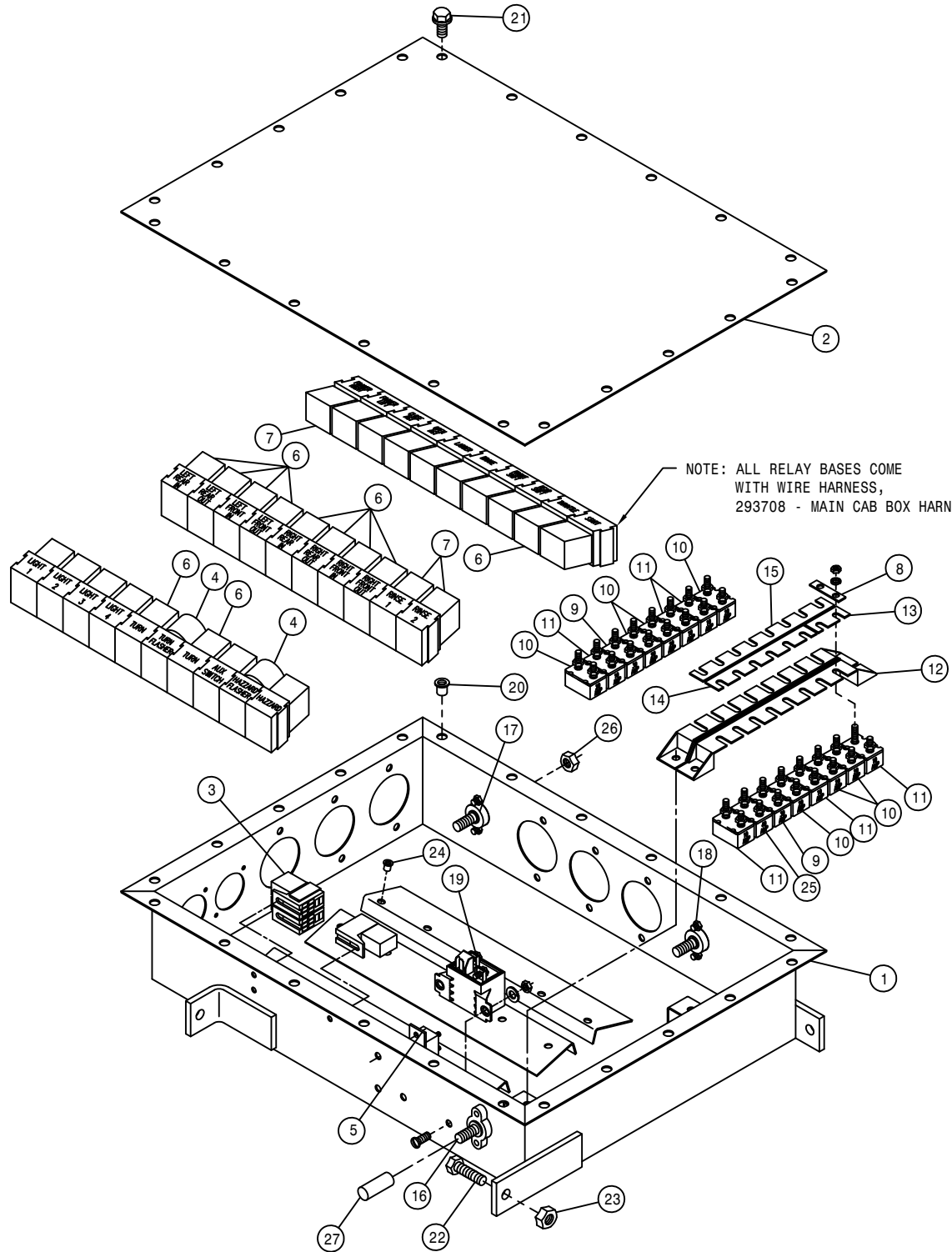

CAB ELECTRICAL BOX ASSEMBLY

DET.	QTY	PART NO.	DESCRIPTION
1	1	342841	CAB ELECTRICAL BOX WLD
2	1	342847	CAB ELECTRICAL BOX COVER
3	3	291781	MICRO RELAY, BOSCH 12V SPDT
4	2	291564	FLASHER, 12V 3-PIN ELECTRONIC
5	1	291197	CIRCUIT BREAKER,30AMP,INLINEMT
6	11	291752	RELAY, SPDT 12V 50A-NO 5-TERM
7	17	291751	RELAY, SPST 12V 40A-NO 5-TERM
8	1	291683	BUSS BAR,2 GANG CIRCUIT BREAKR
9	2	291574	CIRCUIT BREAKER,30AMP W/O MT
10	7	291573	CIRCUIT BREAKER,20AMP W/O MT
11	6	291575	CIRCUIT BREAKER,10AMP W/O MT
12	2	291757	BREAKER MTG BRKT, 8-GANG NYLON
13	1	291796	BUSS BAR,2-GANG FOR 291757
14	1	291797	BUSS BAR, 6-GANG FOR 291757
15	1	291758	BUS BAR,8-GANG FOR 291757
16	1	291748	TERM BLOCK,BLACK,1/4-20 THRU
17	1	291749	TERM BLOCK,BLACK,3/8-16 THRU
18	1	291750	TERM BLOCK,RED,3/8-16 THRU
19	1	657371	RELAY, 12 VOLT 75 AMP
20	22	470086	1/4UNC NUTSERT .020-.100MATL
21	22	470122	1/4UNC X 1/2 FLANGE HEX BOLT
22	3	900129	3/8UNC X 1" HEX BOLT
23	3	914004	3/8UNC HEX STOVER NUT
24	16	470165	10-32 NUTSERT .020-.100 MATL
25	1	291584	CIRCUIT BREAKER,40AMP W/O MT
26	2	910004	3/8UNC HEX NUT
27	1	629763	CAPPLUGS CAP, .250 X 1.00 VINYL

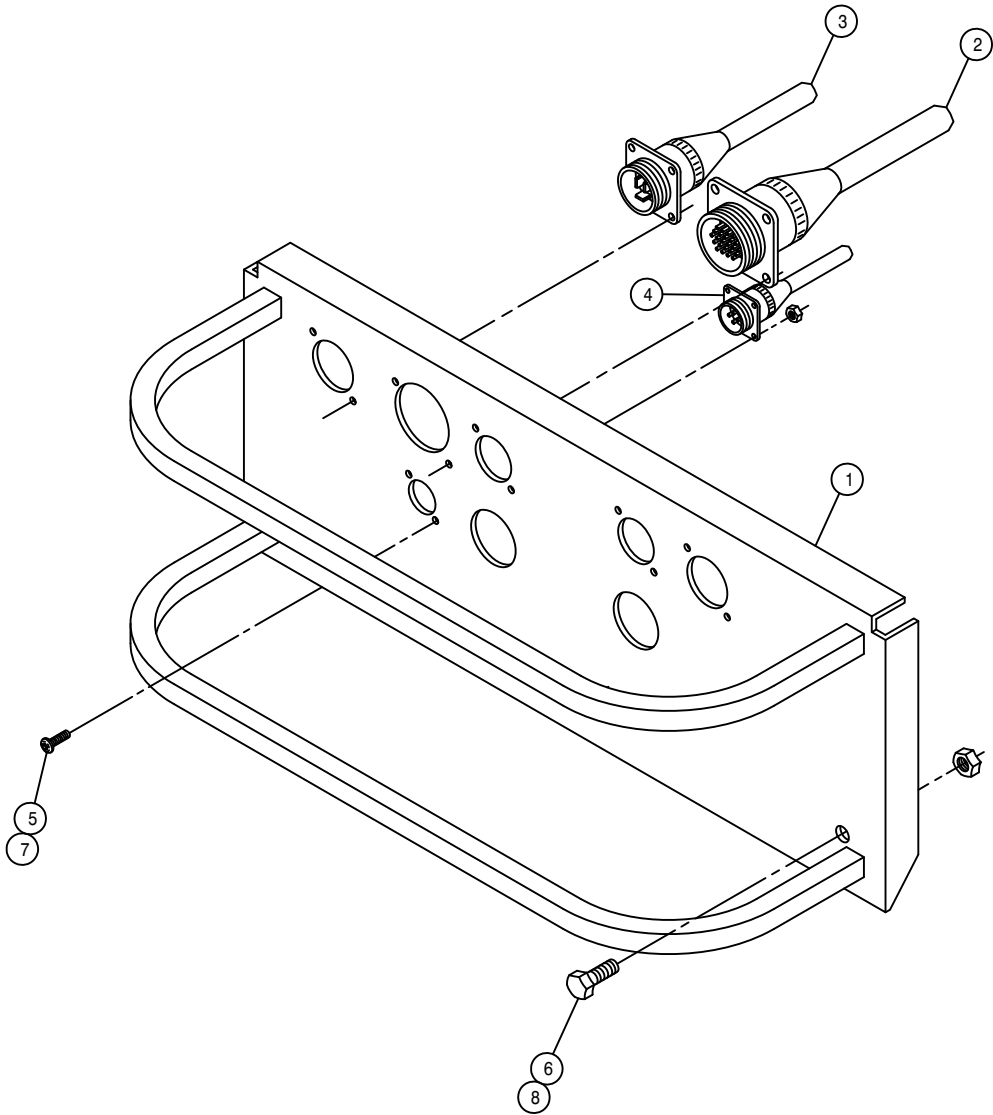

RECEPTACLE PANEL ASSEMBLY

DET.	QTY	PART NO.	DESCRIPTION
1	1	342957	FRT RECEPTACLE PNL WLD, STS 03
2	1	293642	JUMPER HARNESS,CAB-RECEPTCL MT
3	1	293710	POWER HARNESS, MAIN STS 03
4	1	293672	FLO CTRL CABLE,5FT RAVEN STSC
5	6	473989	6-32 X 3/4 BUTTON SOC CAP SCR
6	2	900064	5/16UNC X 3/4 HEX BOLT
7	6	910022	6-32 HEX NUT
8	2	914002	5/16UNC HEX STOVER NUT

CAB ASSEMBLY

DET.	QTY	PART NO.	DESCRIPTION
1	4	470175	10-32 HEX FLANGE LOCK NUT
2	4	903905	10-32X1 1/2 SLT RD HD MACH SCR
3	4	343101	CAB HINGE PIN, DRILLED STS12
4	2	291828	WORKLIGHT W/O BULB, CAB, STS12
5	2	291829	WORKLIGHT BULB FOR 291828, STS
6	1	343000	CAB, NEW HOLLAND FX DISCOVERY
7	26	485053	POP RIVET 3/16 X 3/8
8	4	472335	3/8UNC X 2" STUD BOLT
9	2	520064	HOSE CLAMP NO 64 STAINLESS
10	2	611125	3/4MJIC-3/4MOR ADPTR
11	1	618241	3/4MJIC-90-3/4MOR LBO
12	1	618443	3/4MJIC-90-3/4MOR EX LG LBO
13	1	657435	FILTER BOX W/FILTERS STS12
14	1	749321	STEERING CONTROL MTR 14.1CI
15	6	900002	1/4UNC X 3/4 HEX BOLT
16	1	657437	CHARCOAL FILTER FOR 657435
17	4	910004	3/8UNC HEX NUT
18	1	343004	WINDSHIELD, STS12 CAB 2000
19	4	914000	1/4UNC HEX STOVER NUT
20	4	920502	3/8 LOCK WASHER
21	2	343134	REAR CAB MT WLD, STS10
22	1	343019	CAB STABILIZER MT WLD
23	1	343022	REAR CAB COVER PLATE
24	1	343023	STEERING MTR SPACER STS12
25	1	343154	AIR DUCT HOSE, 4" X 60" LG
26	1	657436	PANEL FILTER FOR 657435
27	6	470121	1/4UNC HEX FLANGE LOCK NUT
28	2	910009	1/2UNF HEX NUT
29	4	520080	HOSE CLAMP NO 10 STAINLESS
30	1	601465	HOSE, 5/8 X 19 HEATER
31	1	601466	HOSE, 5/8 X 21 HEATER
32	3	343027	DIMMER SWITCH MT PLT
33	1	343026	DIMMER SWITCH MT WLD
34	1	290412	DIMMER SWITCH
35	1	657442	A/C HOSE,06-06F90-06M90-33"
36	1	657445	A/C HOSE,08-10F90-10M90-35"
37	1	343072	CAB STABILIZER ROD
38	1	343025	CAB STEP PLATE
39	2	914004	3/8UNC HEX STOVER NUT
40	2	900129	3/8UNC X 1" HEX BOLT
41	2	900267	1/2UNC X 2" HEX BOLT
42	2	900274	1/2UNC X 4" HEX BOLT
43	4	914008	1/2UNC HEX STOVER NUT
44	2	473976	ROD END, .50B, .50-20UNF RH MALE
45	2	473775	12MM-1.75 X 30MM HEX BOLT
46	2	473784	12MM LOCK WASHER
47	6	470154	CABLE TIE, 11.75" BLK PLASTIC
48	2	601552	HOSE, 1/2 X 4 CLEAR VINYL
49	2	619014	1/2" HOSE MENDER
50	2	657451	A/C KAZOO, 1/2" X 2" LONG
51	1	291214	ANTENNA
52	1	343118	A/C FILTER ELEMENT, CAB STS12
53	4	471005	1/4 28 X 1/2 GREASE ZERK
54	4	470122	1/4UNC X 1/2 FLANGE HEX BOLT
55	1	343153	CAB AIR FILTER BOX MT, STS 03

39

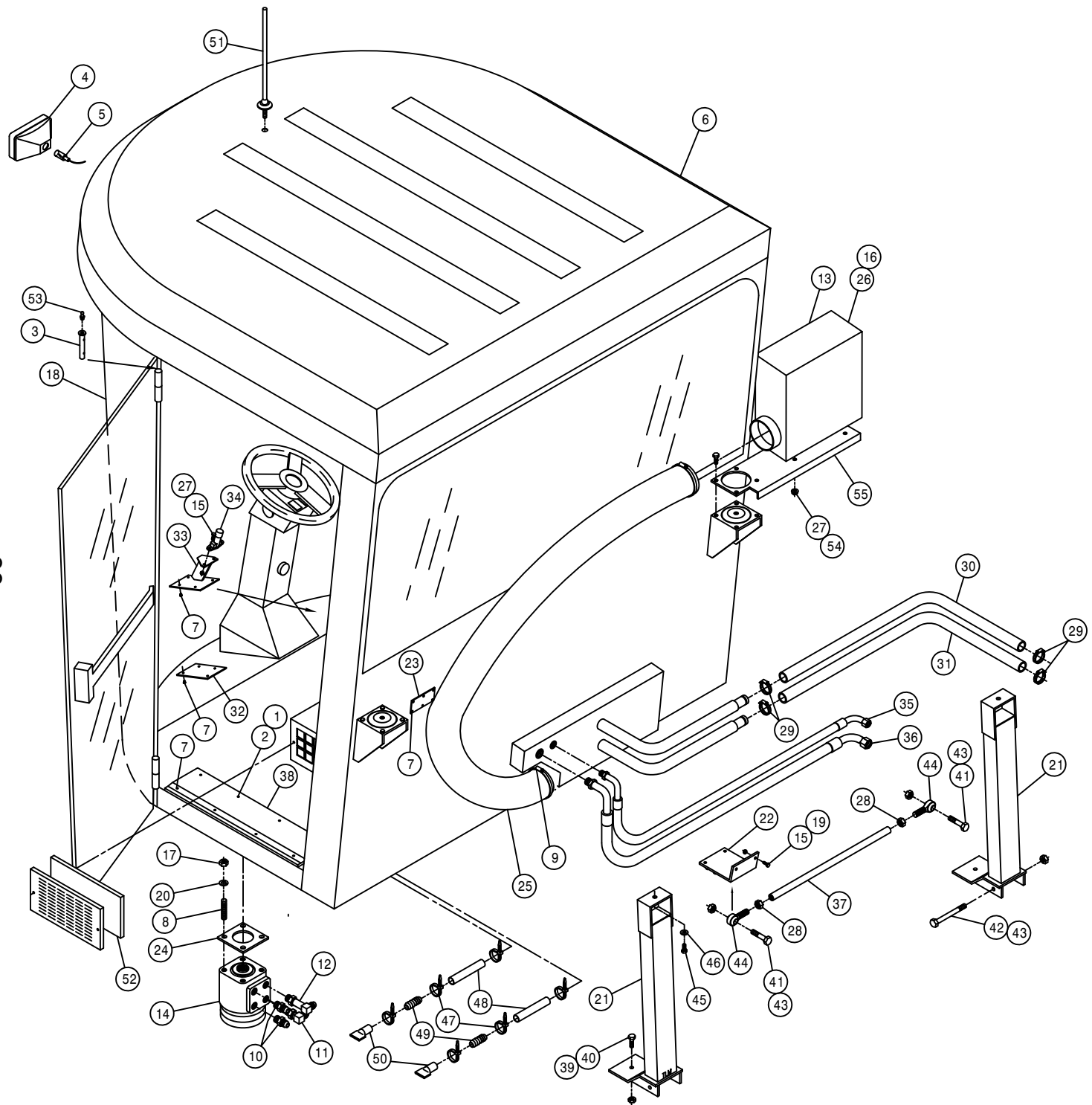

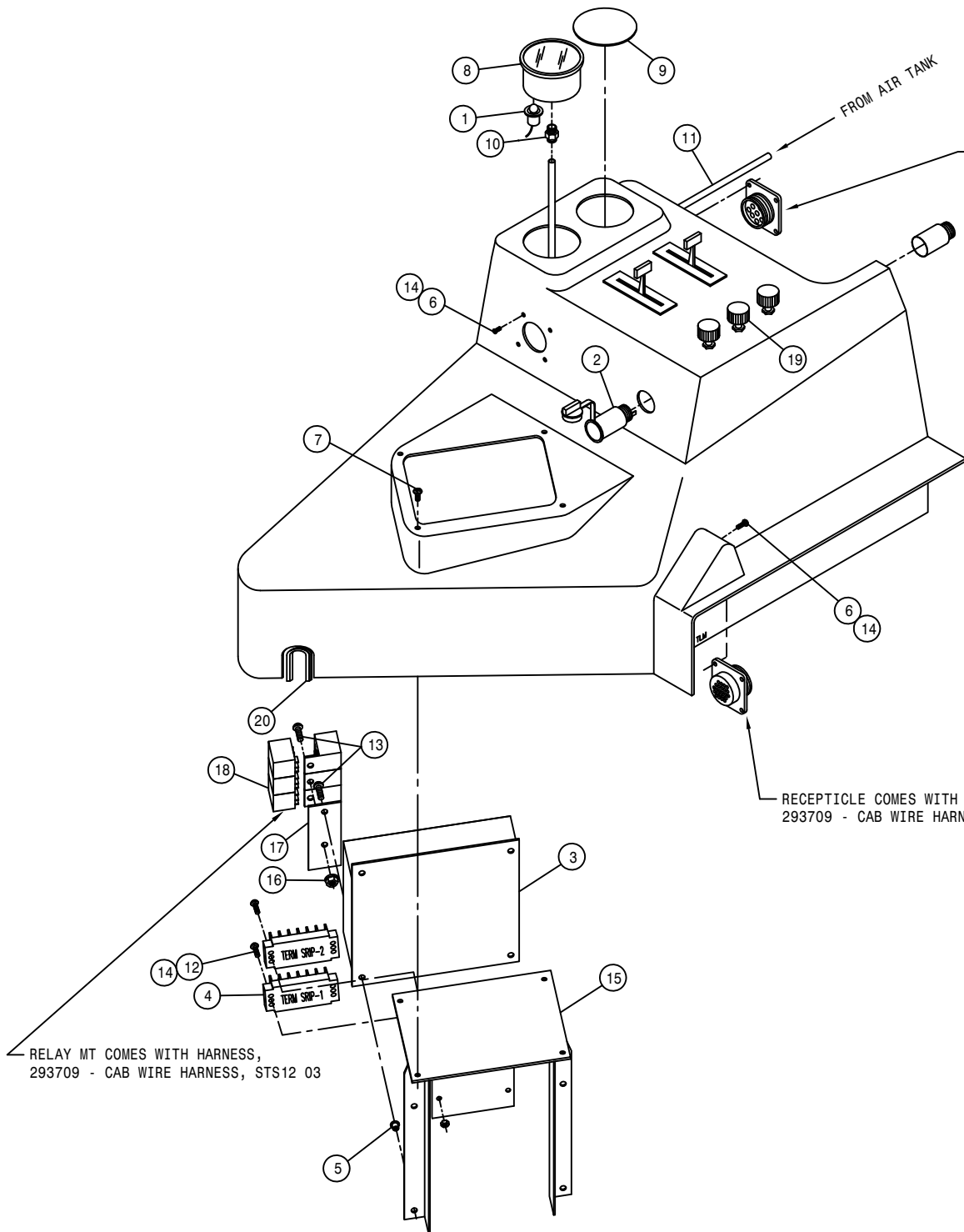

HEATER CONTROL PANEL ASSEMBLY

DET.	QTY	PART NO.	DESCRIPTION	
	1	291612	LIGHT KIT FOR 2" GAUGE	
	2	291648	POWER POINT RECEPTACLE	
	3	291787	INPUT MODULE, ATI	
	4	293093	TERMINAL BLOCK 6 POS - 2 ROW	
	5	470165	10-32 NUTSERT .020-.100 MATL	
	6	473989	6-32 X 3/4 BUTTON SOC CAP SCR	
	7	473990	8-15 X 3/4 PHIL PAN SMS TY-A	
	8	701311	AIR PRESS GAUGE, 150PSI, PNL MT	
	9	701312	GAUGE BLANK	
	10	711038	1/8FNPT-1/4 NYL TUBE FTG	
	11	601486	HOSE, 1/4 X 215 AIR	
	12	903814	6-32 X 3/4 SLT RD HD MACH SCR	
	13	903883	10-32 X 1/2 SLT RDHD MACH SCR	
	14	910022	6-32 HEX NUT	
	15	343062	CONSOLE COVER WLD, CAB STS	
	16	470175	10-32 HEX FLANGE LOCK NUT	
	17	343067	RELAY BRKT	
	18	291781	MICRO RELAY, BOSCH 12V SPDT	
	19	343114	SWITCH, CAB FAN STS12 2000	
	20	.5	193011	EDGE GUARD, BLK

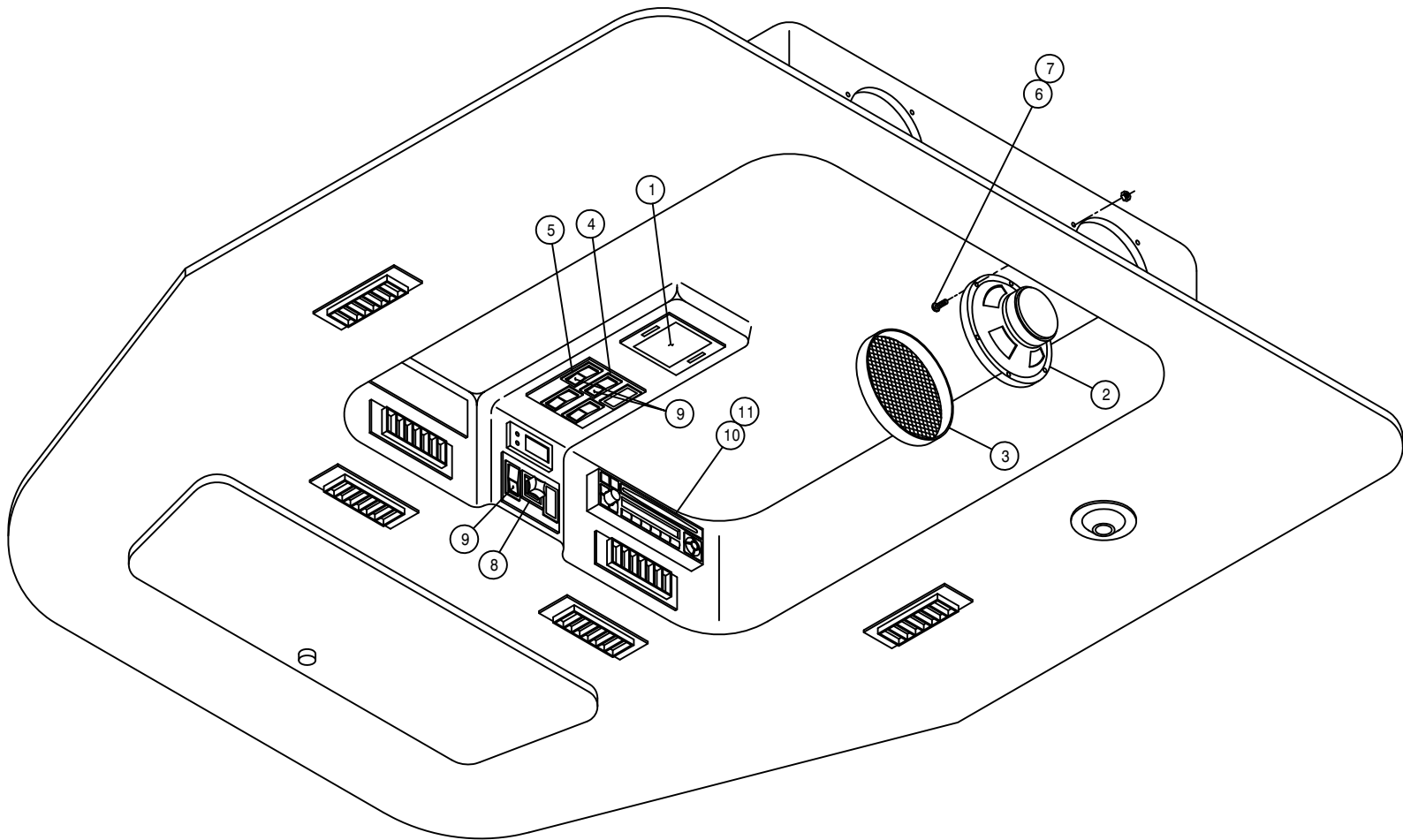

HEADLINER ASSEMBLY

DET. QTY PART NO. DESCRIPTION

1	1	343123	DOME LIGHT, CAB STS
2	2	291219	SPEAKER, 5 1/4"RD
3	2	291319	SPEAKER GRILLE, ROUND SNAP ON
4	1	291627	SWITCH,2P(ON)OFF(ON) 511-058
5	1	291775	SWITCH, LOCK OFF/ON 511-172
6	6	903812	6-32 X 1/2 SLT RD HD MACH SCR
7	6	910022	6-32 HEX NUT
8	1	291798	MIRROR SWITCH FOR 470316
9	3	291628	LENS, GREEN 596-650
10	1	291835	RADIO, AM/FM/CD/WB CRC-5320
11	1	291836	WIRE HARNESS FOR 291835 RADIO

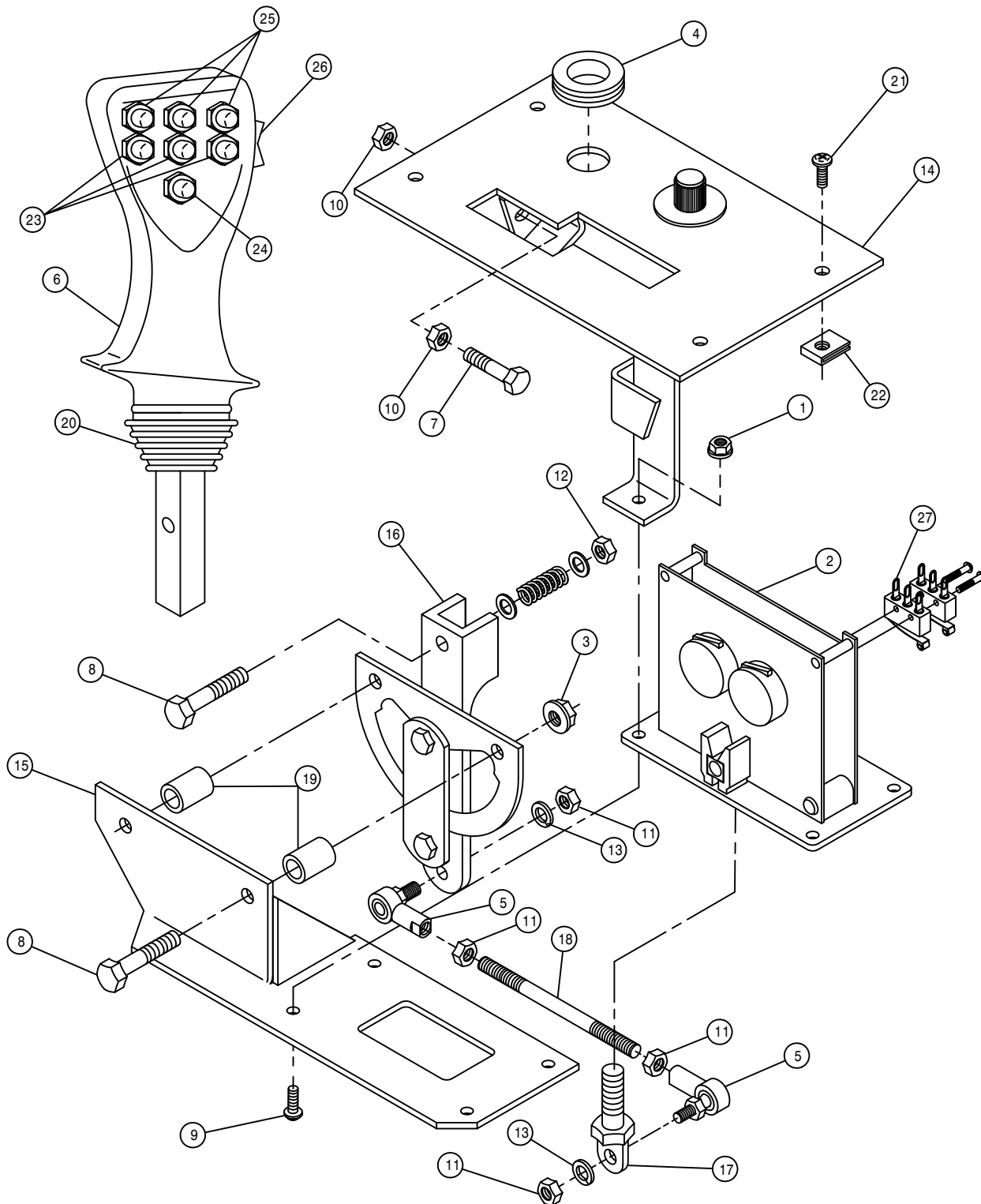

HYDROSTATIC CONTROL LEVER ASSEMBLY

DET.	QTY	PART NO.	DESCRIPTION
	4	169028	10-24 HEX FLANGE LOCK NUT
	1	291760	CONTROL HANDLE & POTENTIOMETER
	2	470121	1/4UNC HEX FLANGE LOCK NUT
	4	470296	GROMMET, .750ID .062GW 1.062GD
	2	473918	BALL JOINT 1/4-28 FEM STUDED
	6	785080	FASSE CTRL HANDLE, C12L4'11TRM
	7	900003	1/4UNC X 1" HEX BOLT
	8	900005	1/4UNC X 1 1/2 HEX BOLT
	9	903888	10-24 X 3/4 SLT RDHD MACH SCR
	10	910000	1/4UNC HEX NUT
	11	910001	1/4UNF HEX NUT
	12	914000	1/4UNC HEX STOVER NUT
	13	920500	1/4 LOCK WASHER
	14	343031	HYDRO LEVER MT PLT WLD
	15	343037	HYDRO LEVER MT WLD
	16	343040	HYDST CTRL LEVER
	17	343041	HYDRO LINKAGE BOLT WLD
	18	343043	HYDRO LINKAGE ROD
	19	343044	HYDRO LEVER SPACER
	20	785081	BELLOW,FASSE CTRL HANDLE785080
	21	473990	8-15 X 3/4 PHIL PAN SMS TY-A
	22	470172	# 8 SPEED NUT
	23	291883	SWITCH,PB 3TRM MOM O, RED
	24	291882	SWITCH,PB SPDT STAT O, GREEN
	25	291884	SWITCH,PB 3TRM MOM O, GRAY
	26	291885	SWITCH,ROCKER SPDT STAT
	27	291827	MICRO SWITCH FOR 291760

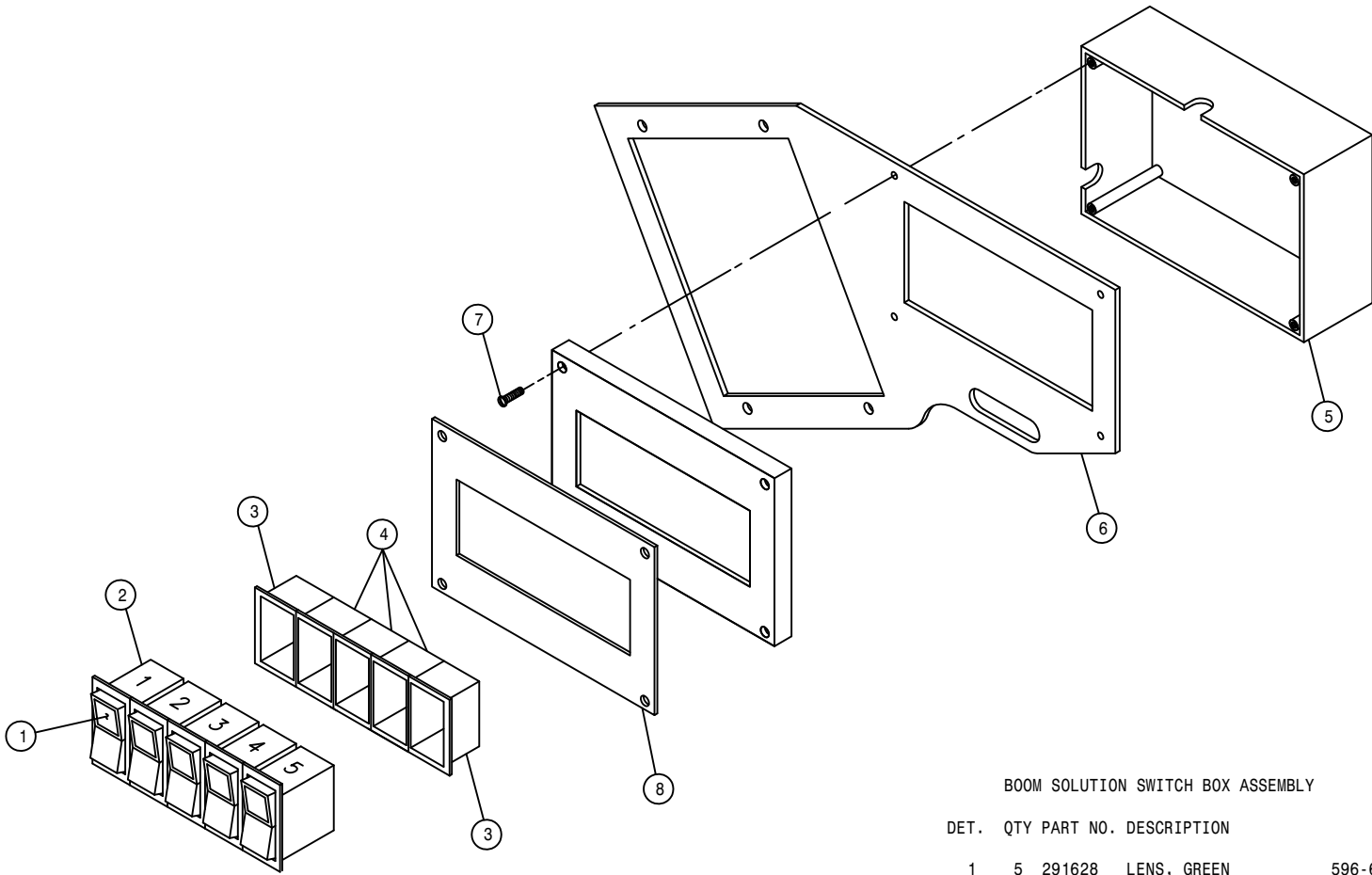

BOOM SOLUTION SWITCH BOX ASSEMBLY

DET.	QTY	PART NO.	DESCRIPTION
1	5	291628	LENS, GREEN 596-650
2	5	291699	SWITCH, ON/OFF 511-110
3	2	293246	END BEZEL, 594-802
4	3	293247	CENTER BEZEL, 594-801
5	1	343049	BOOM SWITCH BOX
6	1	343165	BOOM SOLU SWITCH BOX MT PLT 03
7	4	473848	3MM-0.50 X 25MM PHILHD SCREW
8	1	650101	DECAL, BOOM SPRAY VALVE SWITCH

SWITCH PANEL ASSEMBLY

DET. QTY PART NO. DESCRIPTION

1	1	291850	SWITCH PANEL,W/SWITCH STS10 03
2	1	291622	SWITCH,1P ON/OFF 511-003
3	1	291626	SWITCH,2P ON/OFF/ON 511-053
4	1	291625	SWITCH,2P ON/ON 511-108
5	9	291627	SWITCH,2P(ON)OFF(ON) 511-058
6	1	291671	SWITCH,2P OFF/ONA/ONAB 511-138
7	1	291672	SWITCH,1P ON/OFF/ON 511-149
8	1	291776	BLANK COVER, 596-273
9	1	291775	SWITCH, LOCK OFF/ON 511-172
10	1	293645	PWR PORT PIGTAIL ASSY, STS 02
11	1	291832	AMP RECEPTCL,17-3 STD,SQ FLG
12	1	291754	AMP RECEPTACLE CAP, 17-SHELL
13	18	473989	6-32 X 3/4 BUTTON SOC CAP SCR
14	18	910022	6-32 HEX NUT
15	1	291773	WARNING PANEL, 6 POSITION
16	1	321021	IGN SWITCH, NON-SEALED
17	2	291782	RELAY BASE,5-PIN MICRO,P/NL MT
18	2	291781	MICRO RELAY, BOSCH 12V SPDT
19	1	343047	RELAY BASE MT BRKT
20	2	920510	#10 LOCK WASHER
21	2	910026	10-24 HEX NUT
22	2	472199	10-24 X 1/2 RD HD MACH SCR
23	7	291628	LENS, GREEN 596-650
24	1	291699	SWITCH, ON/OFF 511-110

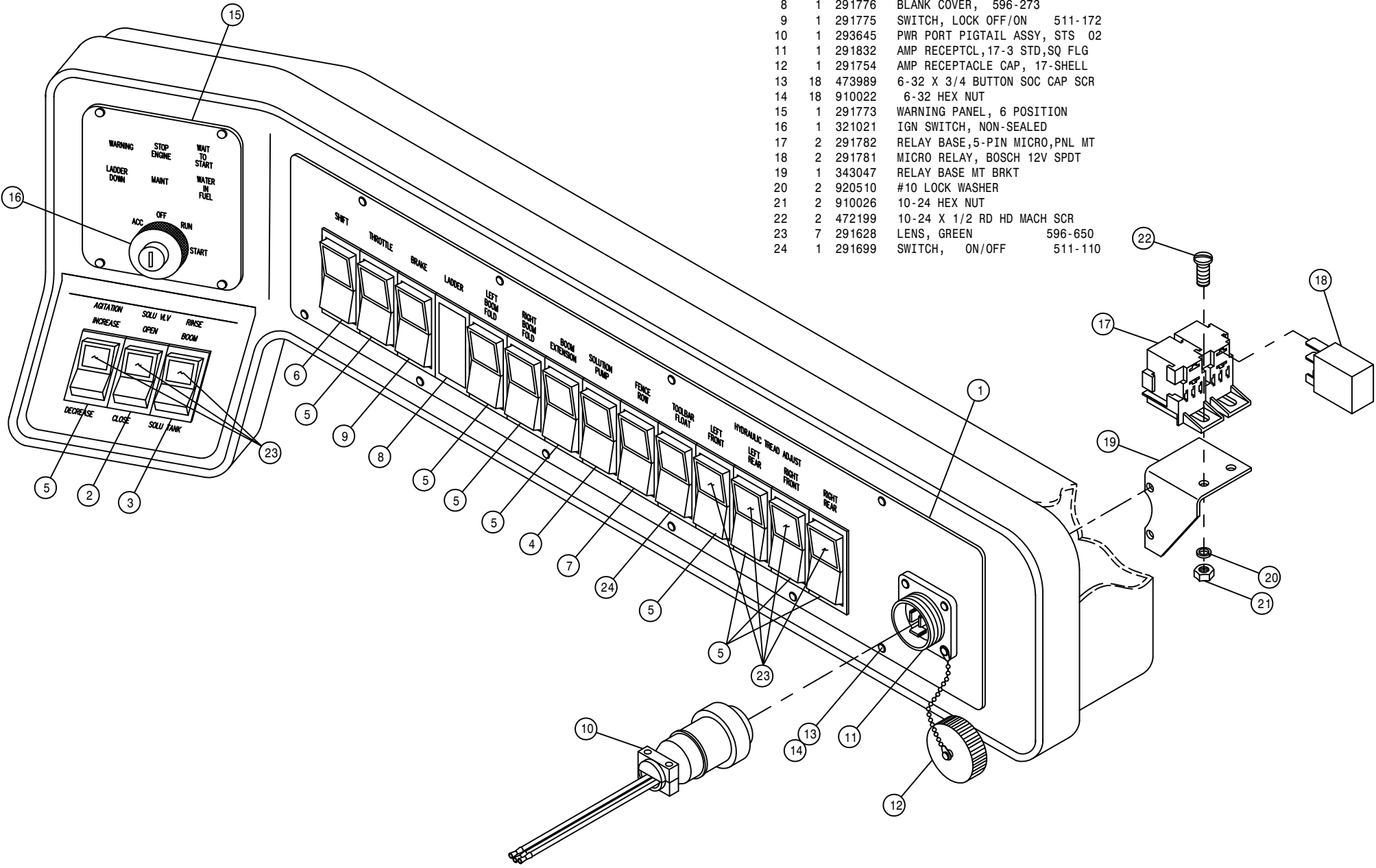

44

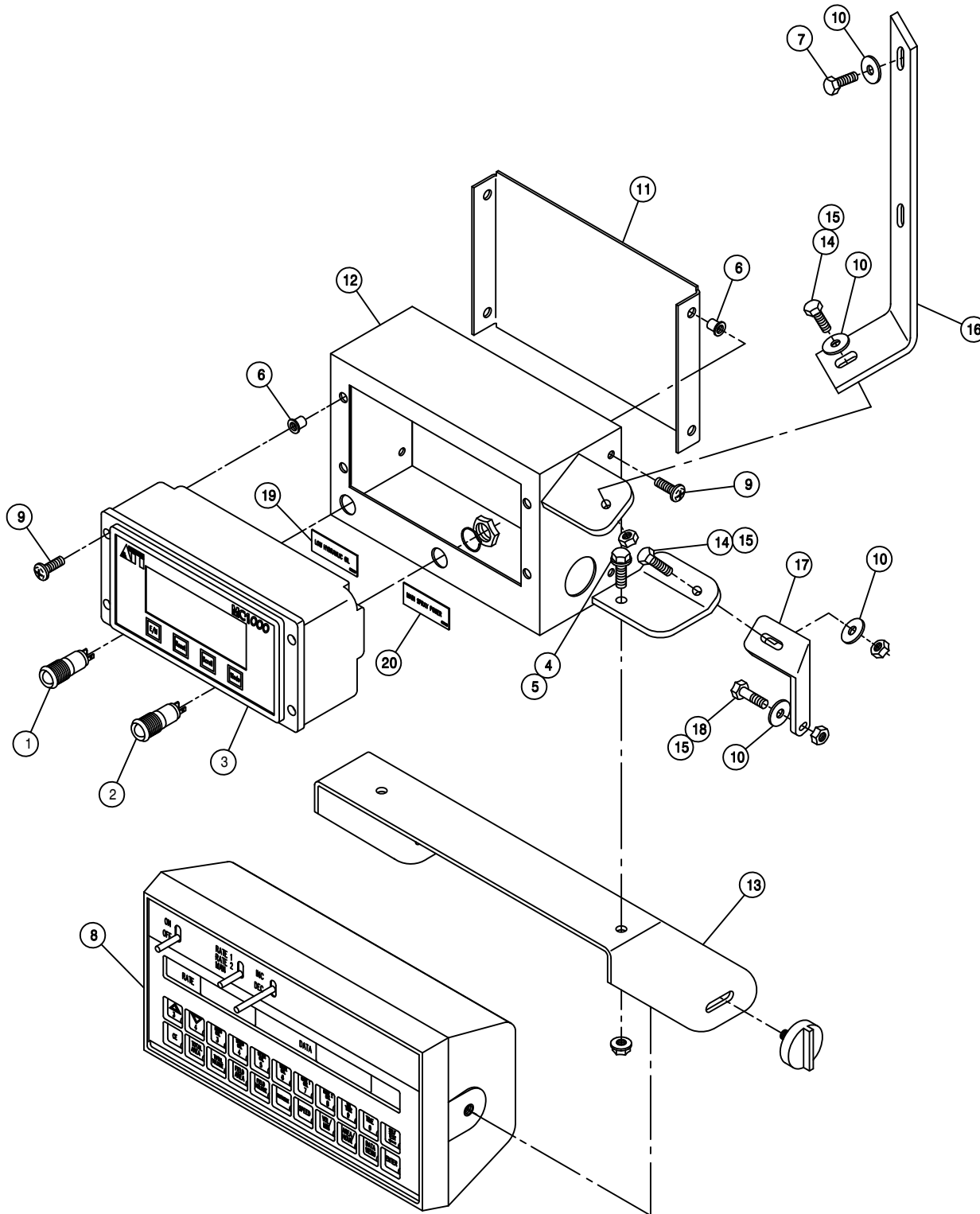

ATI MC1000 CONTROL BOX ASSEMBLY

DET. QTY PART NO. DESCRIPTION

1	1	291740	RED LED IND LIGHT,12V 10MM
2	1	291741	GREEN LED IND LIGHT,12V 10MM
3	1	291761	MESSAGE CENTER, ATI MC1000
4	2	470118	1/4UNC X 3/4 FLANGE HEX BOLT
5	2	470121	1/4UNC HEX FLANGE LOCK NUT
6	8	470165	10-32 NUTSERT .020-.100 MATL
7	2	473787	6MM-1.00 X 25MM HEX BOLT
8	1	690618	CONSOLE, RAVEN 460 W/GPS PORT
9	8	903710	10-32X5/8 PHIL PANHD MACH SCR
10	5	920000	1/4 SAE FLAT WASHER
11	1	343058	ATI MC1000 CTRL BOX COVER
12	1	343053	ATI MC1000 CTRL BOX WLD
13	1	343059	MONITOR MT BRKT, STS
14	2	900003	1/4UNC X 1" HEX BOLT
15	3	914000	1/4UNC HEX STOVER NUT
16	1	343060	ATI MC1000 CTRL BOX UPR SUPP
17	1	343061	ATI MC1000 CTRL BOX LWR SUPP
18	1	900004	1/4UNC X 1 1/4 HEX BOLT
19	1	650109	DECAL, LOW HYDRAULIC OIL
20	1	650108	DECAL, MAIN SPRAY POWER

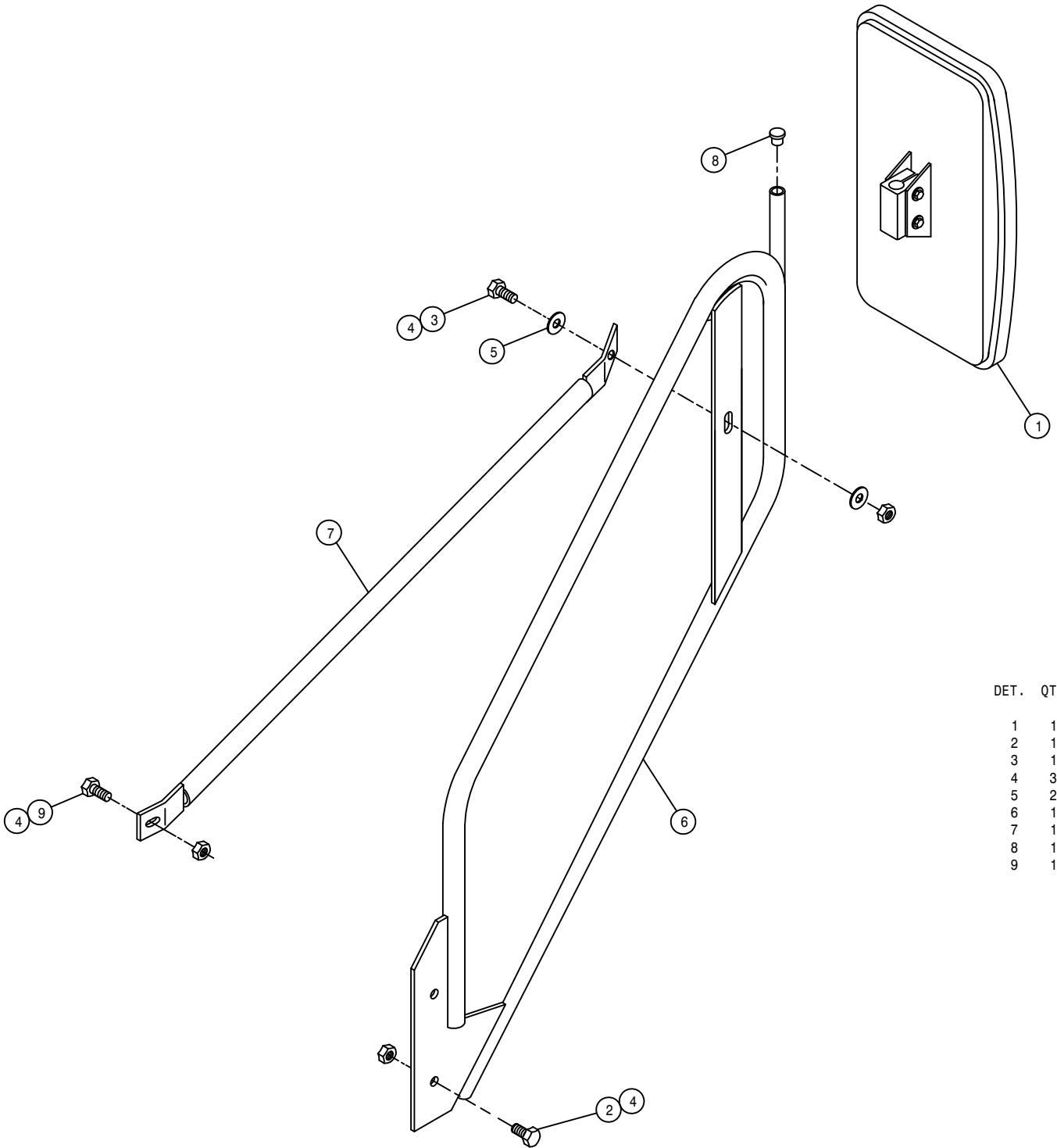

RH MIRROR ASSEMBLY

DET. QTY PART NO. DESCRIPTION

1	1	470348	MIRROR STS10 & STS12
2	1	900129	3/8UNC X 1" HEX BOLT
3	1	900128	3/8UNC X 3/4 HEX BOLT
4	3	914004	3/8UNC HEX STOVER NUT
5	2	920002	3/8 SAE FLAT WASHER
6	1	343073	MIRROR MT TUBE WLD
7	1	343077	RH MIRROR BRACE TUBE BRKT WLD
8	1	629762	CAPLUG, 5/8" RD, BLACK POLY
9	1	900130	3/8UNC X 1 1/4 HEX BOLT

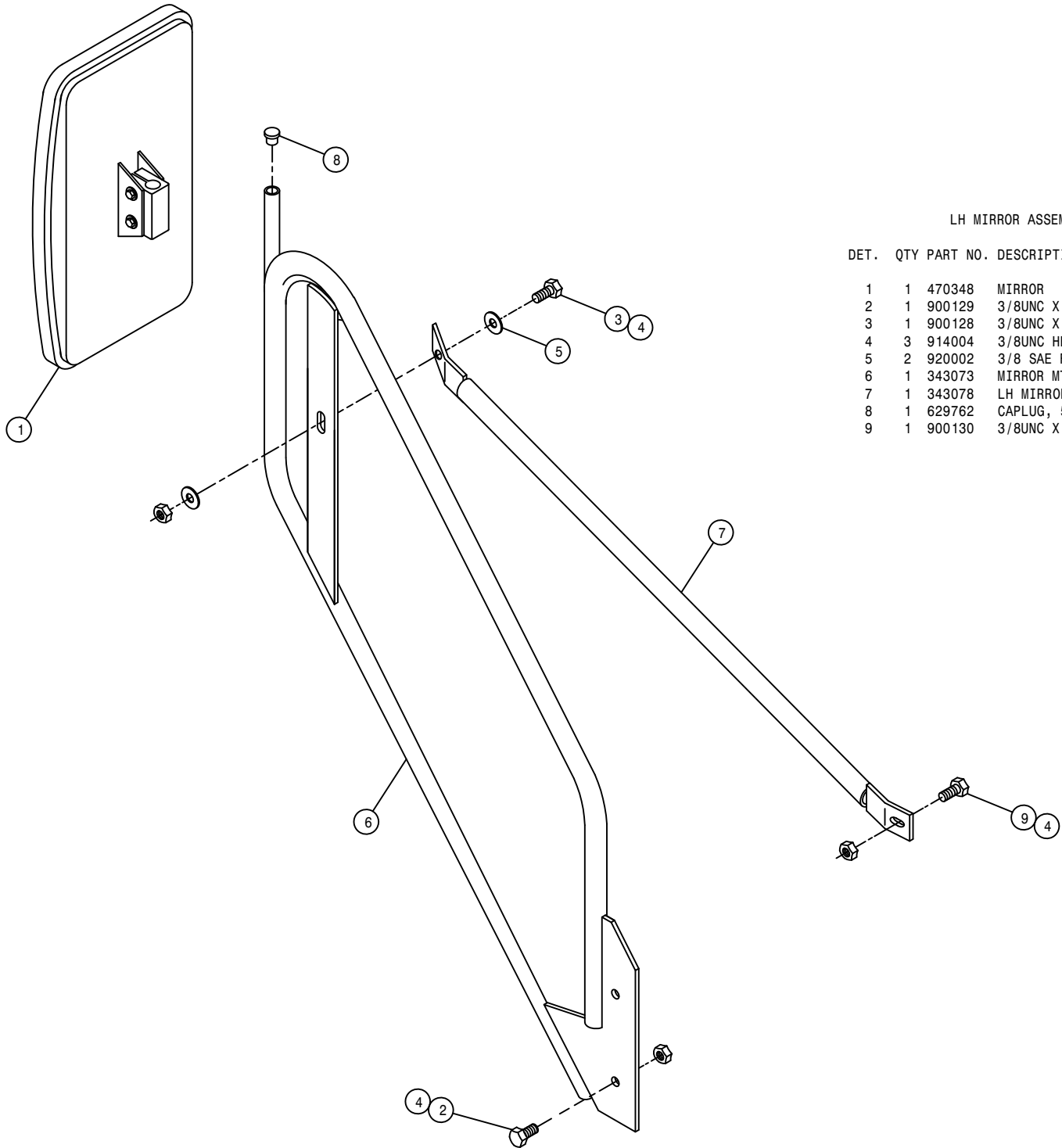

LH MIRROR ASSEMBLY

DET. QTY PART NO. DESCRIPTION

DET.	QTY	PART NO.	DESCRIPTION
1	1	470348	MIRROR STS10 & STS12
2	1	900129	3/8UNC X 1" HEX BOLT
3	1	900128	3/8UNC X 3/4 HEX BOLT
4	3	914004	3/8UNC HEX STOVER NUT
5	2	920002	3/8 SAE FLAT WASHER
6	1	343073	MIRROR MT TUBE WLD
7	1	343078	LH MIRROR BRACE TUBE BRKT WLD
8	1	629762	CAPLUG, 5/8" RD, BLACK POLY
9	1	900130	3/8UNC X 1 1/4 HEX BOLT

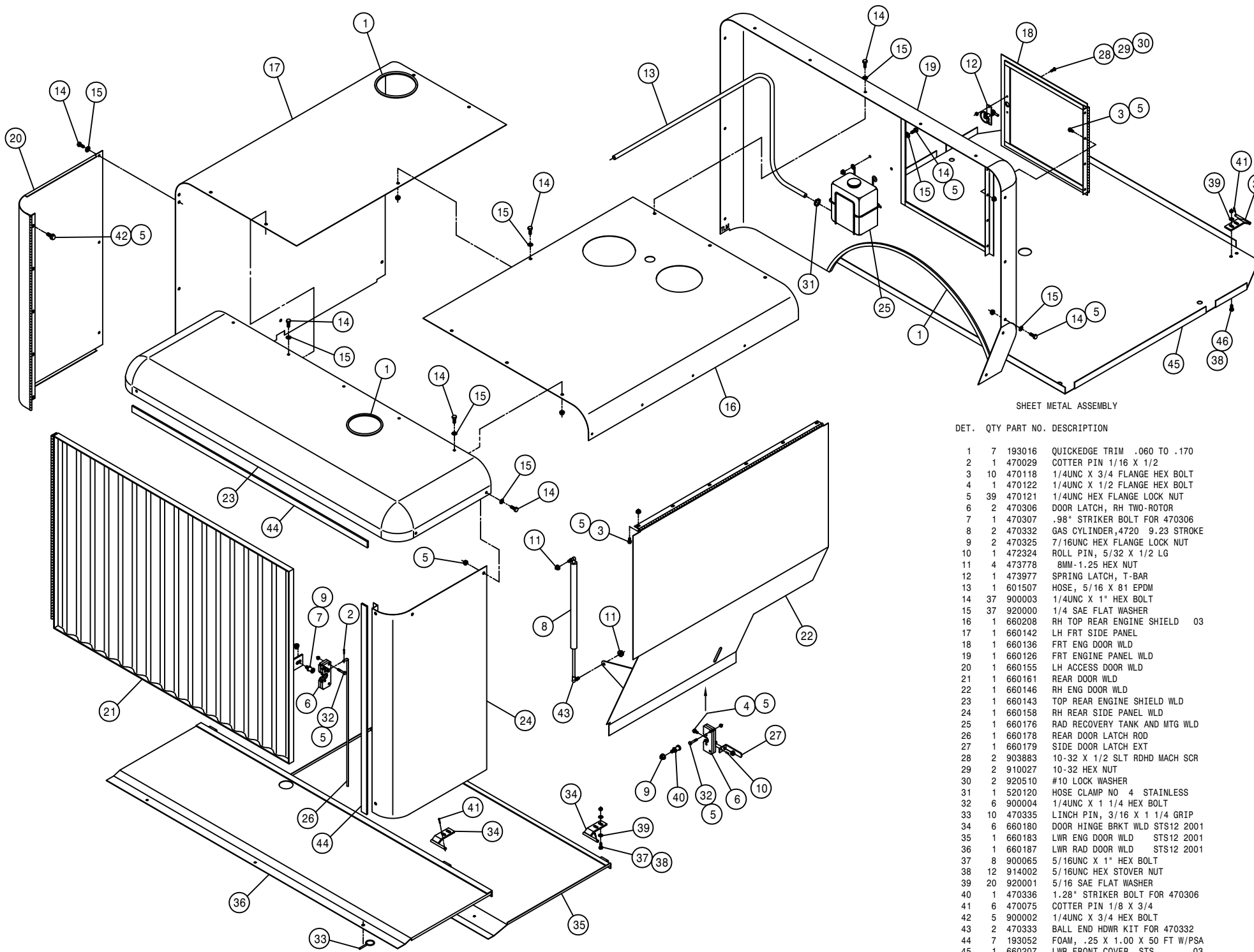

SHEET METAL ASSEMBLY

DET.	QTY	PART NO.	DESCRIPTION
1	7	193016	QUICKEDGE TRIM .060 TO .170
2	1	470029	COTTER PIN 1/16 X 1/2
3	10	470118	1/4UNC X 3/4 FLANGE HEX BOLT
4	1	470122	1/4UNC X 1/2 FLANGE HEX BOLT
5	39	470121	1/4UNC HEX FLANGE LOCK NUT
6	2	470306	DOOR LATCH, RH TWO-ROTOR
7	1	470307	.98" STRIKER BOLT FOR 470306
8	2	470332	GAS CYLINDER,4720 9.23 STROKE
9	2	470325	7/16UNC HEX FLANGE LOCK NUT
10	1	472324	ROLL PIN, 5/32 X 1/2 LG
11	4	473778	BMM-1.25 HEX NUT
12	1	473977	SPRING LATCH, T-BAR
13	1	601507	HOSE, 5/16 X 81 EPDM
14	37	900003	1/4UNC X 1" HEX BOLT
15	37	920000	1/4 SAE FLAT WASHER
16	1	660208	RH TOP REAR ENGINE SHIELD 03
17	1	660142	LH FRT SIDE PANEL
18	1	660136	FRT ENG DOOR WLD
19	1	660126	FRT ENGINE PANEL WLD
20	1	660155	LH ACCESS DOOR WLD
21	1	660161	REAR DOOR WLD
22	1	660146	RH ENG DOOR WLD
23	1	660143	TOP REAR ENGINE SHIELD WLD
24	1	660158	RH REAR SIDE PANEL WLD
25	1	660176	RAD RECOVERY TANK AND MTG WLD
26	1	660178	REAR DOOR LATCH ROD
27	1	660179	SIDE DOOR LATCH EXT
28	2	903883	10-32 X 1/2 SLT RDHD MACH SCR
29	2	910027	10-32 HEX NUT
30	2	920510	#10 LOCK WASHER
31	1	520120	HOSE CLAMP NO 4 STAINLESS
32	6	900004	1/4UNC X 1 1/4 HEX BOLT
33	10	470335	LINCH PIN, 3/16 X 1 1/4 GRIP
34	6	660180	DOOR HINGE BRKT WLD STS12 2001
35	1	660183	LWR ENG DOOR WLD STS12 2001
36	1	660187	LWR RAD DOOR WLD STS12 2001
37	8	900065	5/16UNC X 1" HEX BOLT
38	12	914002	5/16UNC HEX STOVER NUT
39	20	920001	5/16 SAE FLAT WASHER
40	1	470336	1.28" STRIKER BOLT FOR 470306
41	6	470075	COTTER PIN 1/8 X 3/4
42	5	900002	1/4UNC X 3/4 HEX BOLT
43	2	470333	BALL END HDWR KIT FOR 470332
44	7	193052	FOAM, .25 X 1.00 X 50 FT W/PSA
45	1	660207	LWR FRONT COVER, STS
46	4	900064	5/16UNC X 3/4 HEX BOLT

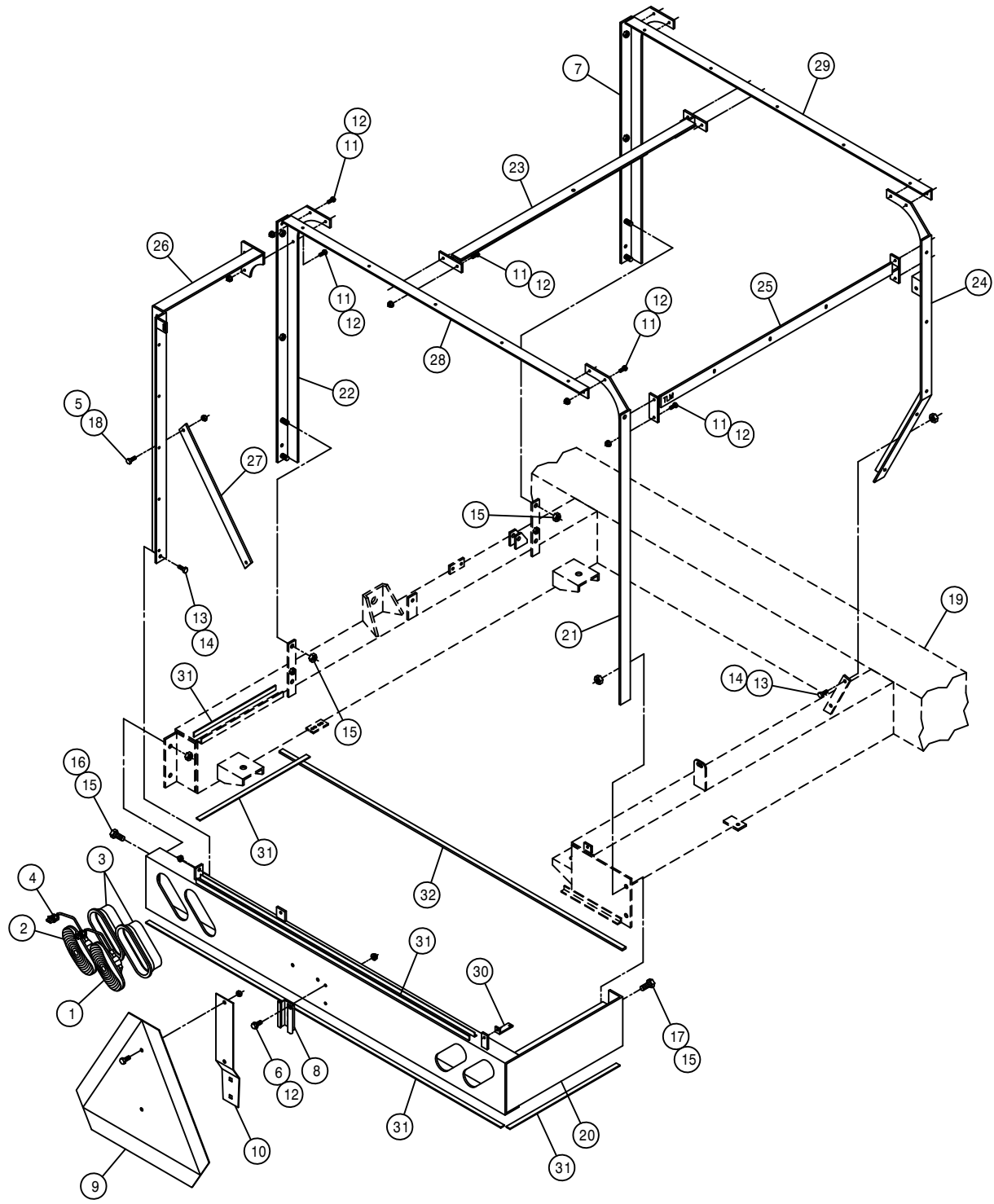

SHEET METAL FRAME ASSEMBLY

DET. QTY PART NO. DESCRIPTION

1	2	291694	RED LAMP, 6 1/2" OVAL 12.8V	
2	2	291695	YELLOW LAMP, 6 1/2" OVAL 12.8V	
3	4	291697	RUBBER MT FOR 6 1/2" OVAL LAMP	
4	4	293515	3-WIRE PIGTAIL ASSY	
5	2	914002	5/16UNC HEX STOVER NUT	
6	2	470118	1/4UNC X 3/4 FLANGE HEX BOLT	
7	1	660101	LH FRT POST WLD	
8	1	472251	MTG SOCKET	
9	1	472249	SLOW MOVING VEHICLE SIGN	
10	1	472250	SPADE MTG BRKT	
11	16	900003	1/4UNC X 1" HEX BOLT	
12	18	470121	1/4UNC HEX FLANGE LOCK NUT	
13	3	900129	3/8UNC X 1" HEX BOLT	
14	3	914004	3/8UNC HEX STOVER NUT	
15	8	914008	1/2UNC HEX STOVER NUT	
16	2	900264	1/2UNC X 1 1/4 HEX BOLT	
17	2	900265	1/2UNC X 1 1/2 HEX BOLT	
18	2	900065	5/16UNC X 1" HEX BOLT	
19	1	361500	MAINFRAME WLD STS	00
20	1	361585	BUMPER WLD	
21	1	660106	RH REAR SUPPORT WLD	
22	1	660107	LH CNTR POST WLD	
23	1	660114	TOP CNTR BRACE ANGLE WLD	
24	1	660100	RH FRT DOOR SUPP WLD	
25	1	660117	RH TOP DOOR SUPPORT WLD	
26	1	660120	LH REAR SUPPORT POST	
27	1	660125	ENG COMPARTMENT BRACE	
28	1	660112	REAR CNTR SUPPORT WLD	
29	1	660110	FRONT CNTR SUPPORT WLD	
30	1	660190	REAR DOOR LATCH ROD GUIDE	01
31	14	193052	FOAM, .25 X 1.00 X 50 FT W/PSA	
32	5	193053	FOAM, .50 X 1.00 X 50 FT W/PSA	

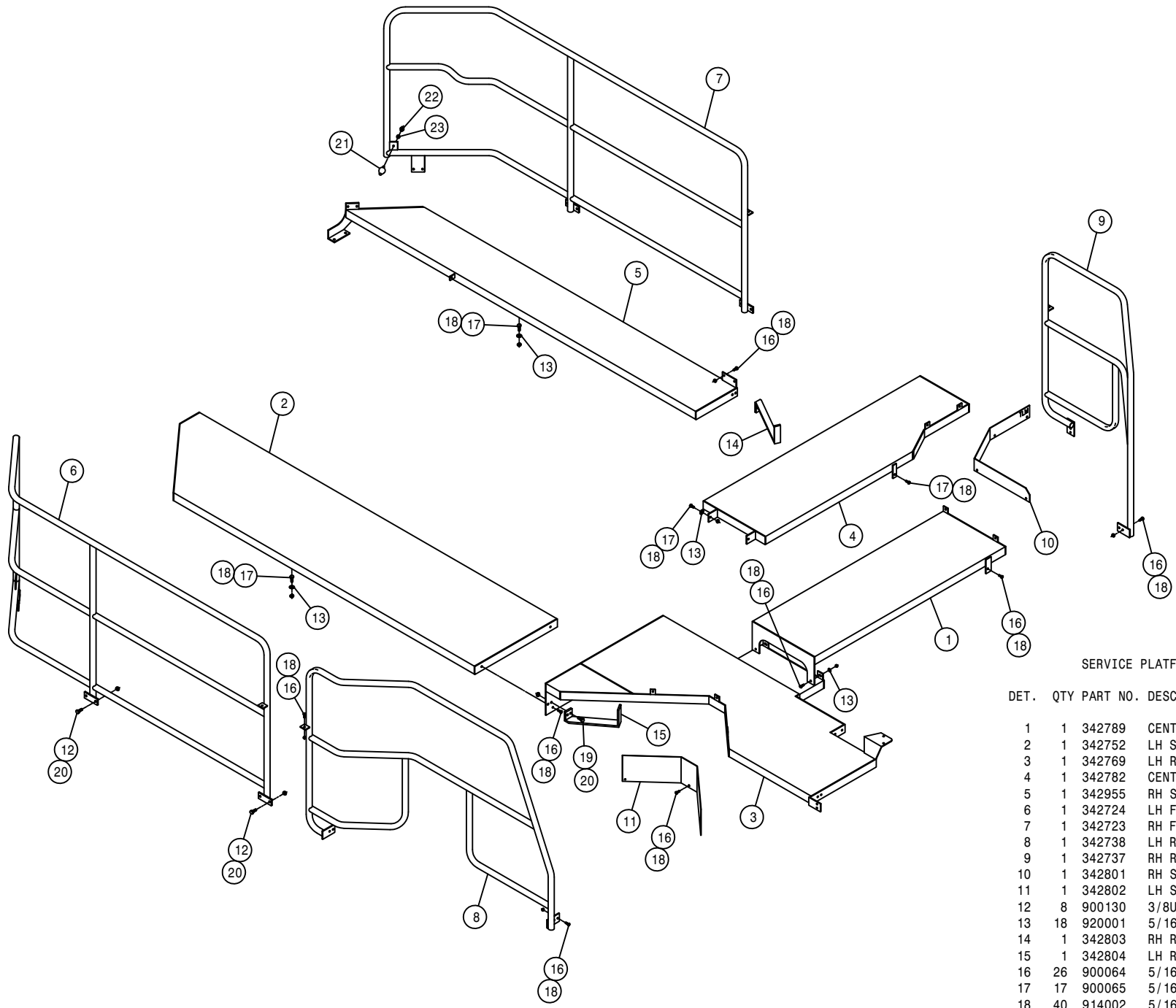

SERVICE PLATFORM ASSEMBLY

DET.	QTY	PART NO.	DESCRIPTION
	1	342789	CENTER SERV PLATFORM WLD
	2	342752	LH SERV PLATFORM WLD
	3	342769	LH REAR SERV PLATFORM WLD
	4	342782	CENTER FRT PLATFORM WLD
	5	342955	RH SERV PLATFORM WLD STS 03
	6	342724	LH FRT HANDRAIL WLD STS 00
	7	342723	RH FRT HANDRAIL WLD
	8	342738	LH REAR HANDRAIL WLD
	9	342737	RH REAR HANDRAIL WLD
	10	342801	RH SERV PLATFORM SHIELD
	11	342802	LH SERV PLATFORM SHIELD
	12	900130	3/8UNC X 1 1/4 HEX BOLT
	13	920001	5/16 SAE FLAT WASHER
	14	342803	RH REAR LEG HOSE SUPPORT
	15	342804	LH REAR LEG HOSE SUPPORT
	16	900064	5/16UNC X 3/4 HEX BOLT
	17	900065	5/16UNC X 1" HEX BOLT
	18	914002	5/16UNC HEX STOVER NUT
	19	900129	3/8UNC X 1" HEX BOLT
	20	914004	3/8UNC HEX STOVER NUT
	21	470314	RUBBER BUMPER,BULLET W/3/8-24S
	22	910005	3/8UNF HEX NUT
	23	920502	3/8 LOCK WASHER

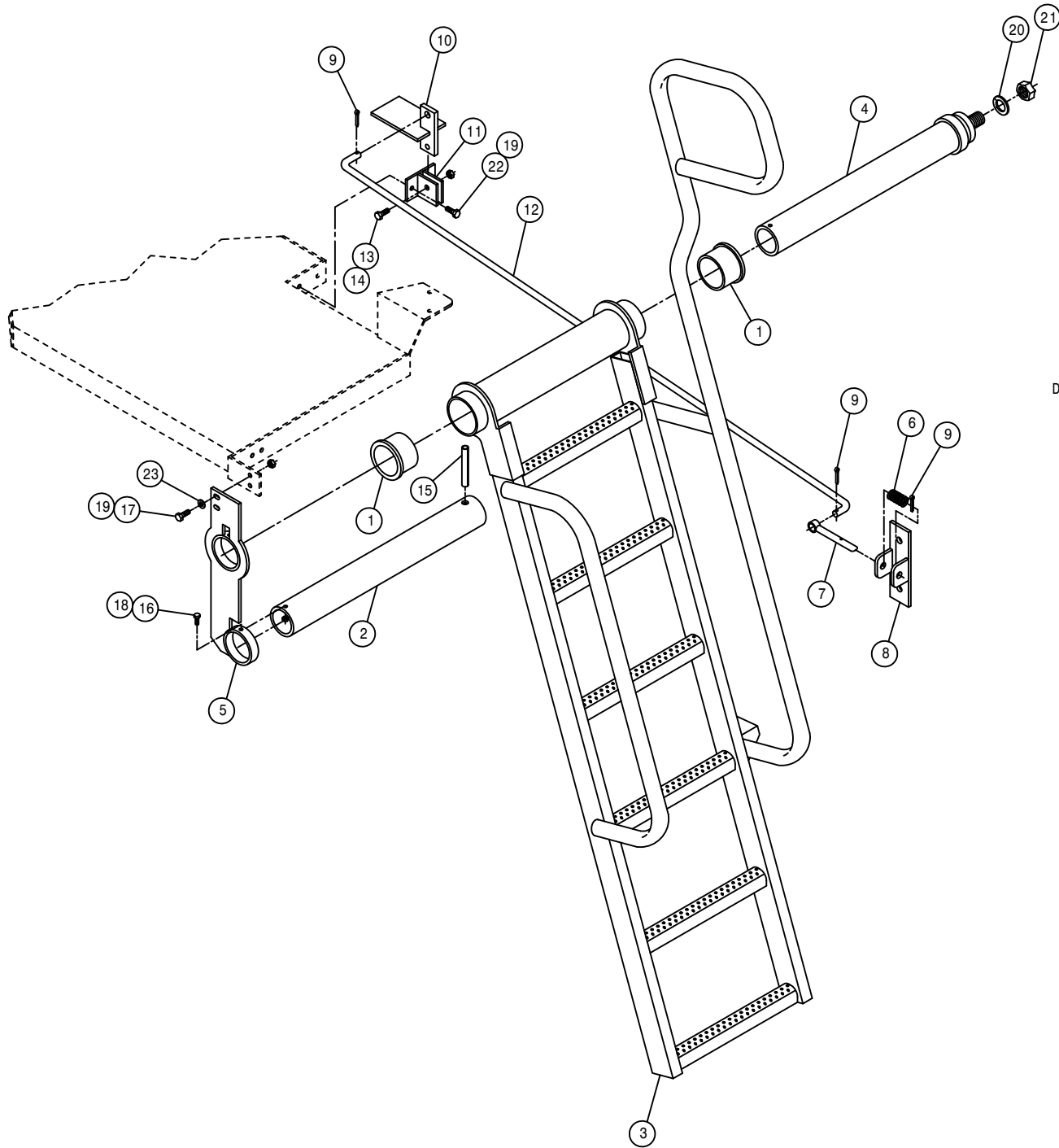

LADDER ASSEMBLY

DET.	QTY	PART NO.	DESCRIPTION
1	2	121102	LADDER PIVOT BEARING, ORKOT
2	1	342805	LADDER MT TUBE
3	1	342920	LADDER WLD, STS10 02
4	1	342930	LADDER PIVOT TUBE WLD, STS10
5	1	342934	LH PLTFRM SUPP BRKT WLD, STS10
6	1	482021	5/8" X 1 5/8" COMPRESS SPRING
7	1	342937	LADDER LATCH PIN WLD, STS10
8	1	342940	LADDER LATCH PIN MT WLD, STS10
9	3	470006	COTTER PIN 1/8 X 1
10	1	342944	LADDER FOOT RELEASE WLD, STS10
11	1	342947	LADDER FOOT REL MT WLD, STS10
12	1	342950	LADDER FOOT RELEASE ROD, STS10
13	1	900127	3/8UNC X 1 1/4 HEX BOLT 1" THD
14	1	914004	3/8UNC HEX STOVER NUT
15	1	473978	ROLL PIN, 1/2 X 3 1/2 LG
16	2	900003	1/4UNC X 1" HEX BOLT
17	2	900065	5/16UNC X 1" HEX BOLT
18	2	914000	1/4UNC HEX STOVER NUT
19	4	914002	5/16UNC HEX STOVER NUT
20	1	920508	1" LOCK WASHER
21	1	914016	1" UNC HEX STOVER NUT
22	2	900064	5/16UNC X 3/4 HEX BOLT
23	2	920001	5/16 SAE FLAT WASHER

1000 GALLON SS TANK ASSEMBLY

DET. QTY PART NO. DESCRIPTION

1	1	763561	LID ASSY FOR 763550 TANK
2	1	763562	10" FILL LID SEAL FOR 763550
3	1	500034	1 1/2NPT-90 ST EL, POLY
4	1	500036	1 1/2"X 1"NPT REDU BUSH, POLY
5	1	500063	1"NPT PIPE PLUG, POLY
6	1	500074	1"NPT-1" HOSE BARB, POLY
7	1	763563	16" MANHOLE SEAL FOR 763550
8	1	500104	1/4NPT-90-1/4 HOSE BARB, POLY
9	3	500194	2"FP FLANGE CLAMP, S.S.
10	3	500195	2"FP FLANGE GASKET EPDM
11	3	500208	3" FLANGE CLAMP, S.S.
12	3	500209	3" FLANGE GASKET EPDM
13	1	505225	1" -1/4"NPT REDU BUSH, POLY
14	1	507103	PIPE CAP, 2.00FNPT S.S.
15	1	507725	REDU BUSH 2 X 1 1/2 S.S.
16	1	507726	PIPE ELBOW, 1"NPT 90D S.S.
17	1	507727	STREET ELBOW, 1 1/2" 90D S.S.
18	1	520067	HOSE CLAMP NO 28 STAINLESS
19	1	520069	HOSE CLAMP NO 6 STAINLESS
20	4	520090	HOSE CLAMP NO 16 STAINLESS
21	1	601471	HOSE, 1" X 60 CLEAR VINYL
22	1	716100	1" HOSE BARB X 1"MNPT S.S.
23	1	716106	1 1/2"HOSE BARB-1 1/2MNPT S.S.
24	1	763570	1000 GAL SS TANK
25	1	500196	2"FP FLANGE-2" HOSE BARB POLY
26	1	500219	2"FP FLANGE-90-2"FP FLANGE LBO
27	1	696252	VALVE, KZCO C2I-60A-Y1
28	1	500213	3"FLANGE-90-3"FLANGE LBO POLY
29	1	500210	3" FLANGE-3" HOSE BARB POLY
30	1	696149	BALL VLV, 3" FLANGE
31	2	900064	5/16UNC X 3/4 HEX BOLT
32	2	914002	5/16UNC HEX STOVER NUT
33	3	520145	356 T-BOLT HOSE CLAMP SS
34	1	520141	2.31/2.62 T-BOLT HOSE CLAMP SS
35	2	470321	BALER BELT, 4.00 X 67.00 2-PLY
36	4	482016	SPRING, 1.40 X 3.00 COMPRSN
37	8	920006	3/4 SAE FLAT WASHER
38	4	900416	3/4UNC X 6 1/2 HEX BOLT
39	4	914012	3/4UNC HEX STOVER NUT
40	1	690731	SOLU TUBE, 3.00 S.S. SIDE FILL
41	1	601591	HOSE, 1 1/2 X 53 2BR BLK EPDM
42	1	601574	HOSE, 3 X 36 POLY HELIX EPDM
43	1	601496	HOSE, 1 X 120 1BR BLK EPDM
44	1	601506	HOSE, 3 X 74 POLY HELIX EPDM
45	1	601573	HOSE, 2 X 48 2F-1W EPDM
46	1	601273	HOSE, 1 X 132 1BR BLK EPDM
47	1	601490	HOSE, 1/4 X 95 1 BR BLK EPDM
48	1	601575	HOSE, 3 X 160 POLY HELIX EPDM

NOTE: ITEMS (*) ARE USED WITH THE SIDE FILL OPTION

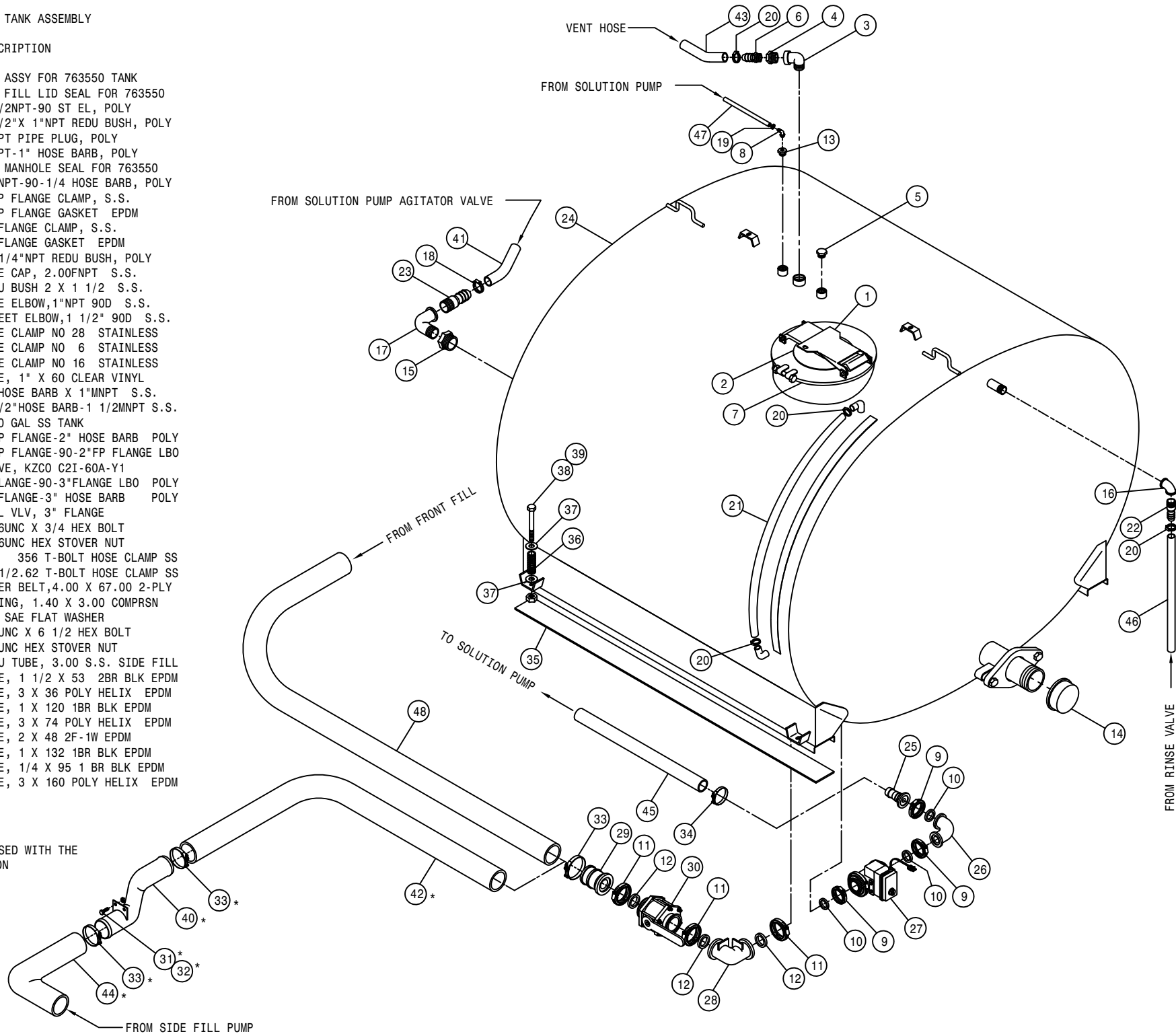

POLY RINSE TANK ASSEMBLY

DET. QTY PART NO. DESCRIPTION

1	3	500024	1"NPT-90-1"HOSE BARB, POLY
2	2	500063	1"NPT PIPE PLUG, POLY
3	1	763553	100 GAL POLY TANK
4	1	763590	POLY RINSE TANK MT WLD STS12
5	1	763594	POLY RINSE TANK MT PAD STS12
6	2	763595	POLY RINSE TNK STRAP ASSY STS
7	2	900392	1/2UNC X 1 1/2 SOCKET CAP SCR
8	4	914008	1/2UNC HEX STOVER NUT
9	2	920004	1/2 SAE FLAT WASHER
10	2	500157	1" FLANGE GASKET EPDM
11	2	500159	1" FLANGE CLAMP, S.S.
12	1	500163	1" FLANGE-1" MNPT ADPTR POLY
13	1	500173	1" FLANGE-90-1" HOSE BARB POLY
14	1	505198	SS PIPE NIPPLE 1.00NPT-3.00
15	1	690660	LINE "T" STRAINER, 1" FLANGE
16	1	690669	100 MESH SCREEN FOR 690660
17	1	696004	BALL VLV,1.00NP 3WAY-SIDE POLY
18	3	520090	HOSE CLAMP NO 16 STAINLESS
19	1	601179	HOSE, 1 X 26 1BR BLK EPDM
20	1	601535	HOSE, 1 X 46 1BR BLK EPDM

NOTE: RINSE TANK FOR SS SOLUTION TANK OPTION IS SHOWN. FOR POLY SOLUTION TANK OPTION USE DETAILS 1,2,AND 3.

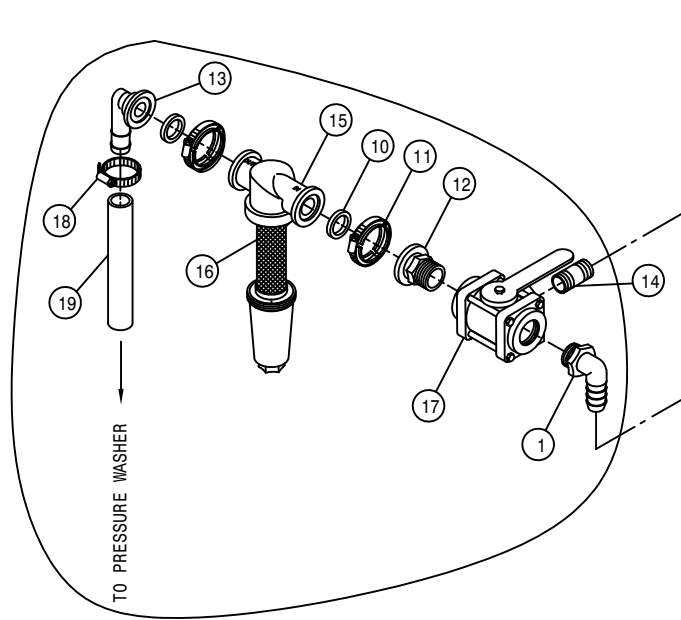

PRESSURE WASHER OPTION

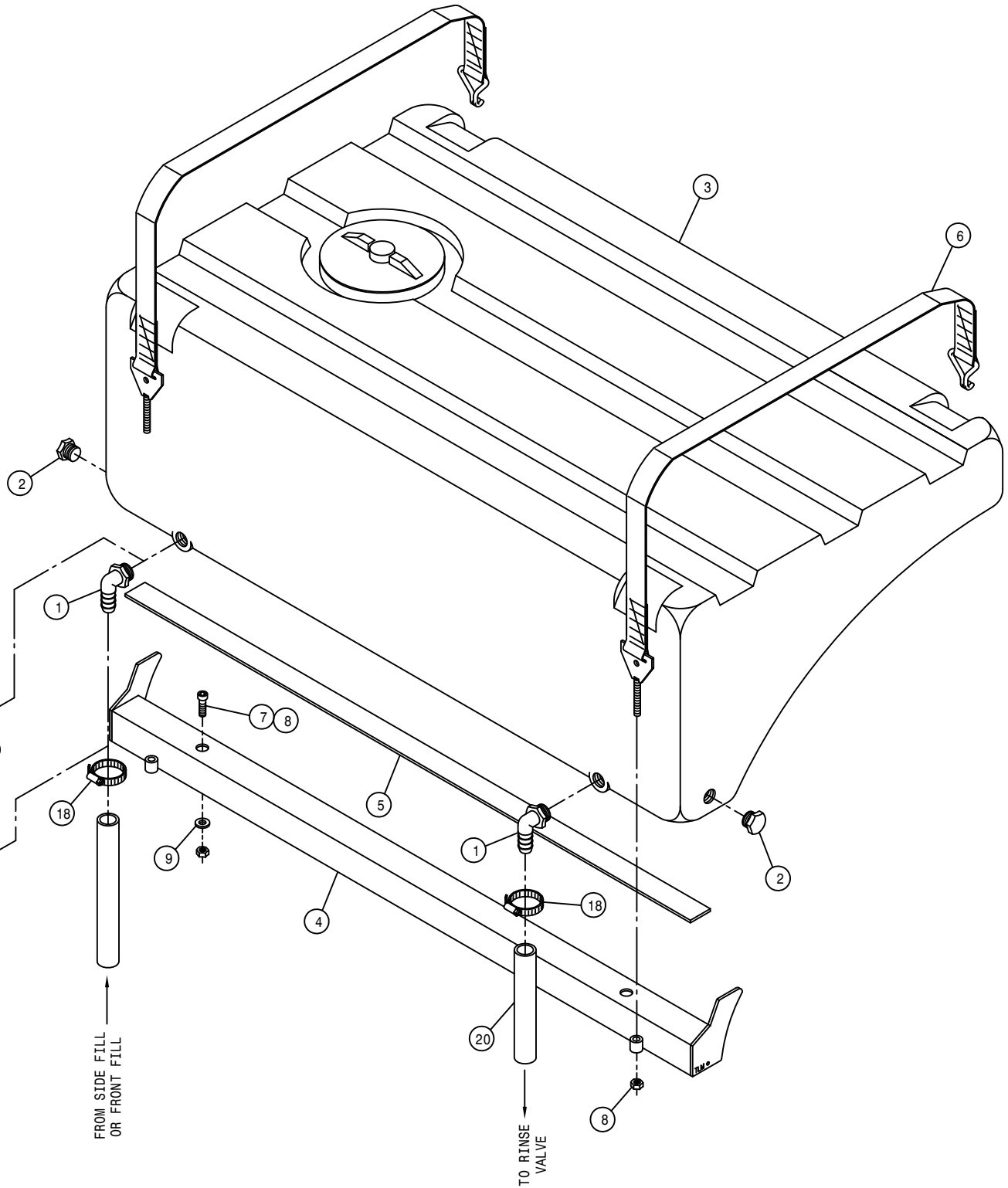

1000 GALLON POLY TANK ASSEMBLY

DET. QTY PART NO. DESCRIPTION

1	1	472349	1/4 X 3/4 20THD-IN TEK TYPE
2	3	500194	2"FP FLANGE CLAMP, S.S.
3	3	500195	2"FP FLANGE GASKET EPDM
4	3	500208	3" FLANGE CLAMP, S.S.
5	3	500209	3" FLANGE GASKET EPDM
6	1	500196	2"FP FLANGE-2" HOSE BARB POLY
7	1	500219	2"FP FLANGE-90-2"FP FLANGE LBO
8	1	696252	VALVE, KZCO C2I-60A-Y1
9	1	500210	3" FLANGE-3" HOSE BARB POLY
10	1	500213	3"FLANGE-90-3"FLANGE LBO POLY
11	1	696149	BALL VLV, 3" FLANGE
12	8	473847	10-12 X 1 PHIL FLAT HD SCR SS
13	5	500026	3/4NPT-90-1"HOSE BARB, POLY
14	1	500043	3/4NPT PIPE PLUG, POLY
15	1	500104	1/4NPT-90-1/4 HOSE BARB, POLY
16	6	500110	3/4NPT BLKHD TANK FITTING POLY
17	1	500112	2"NPT BLKHD TANK FITTING POLY
18	2	500113	2"NPT BLKHD FITTING GASKET
19	1	500114	3"NPT BLKHD TANK FITTING POLY
20	2	500115	3"NPT BLKHD FITTING GASKET
21	10	500158	1 1/2" GASKET FOR 2" FLANGE
22	1	500164	3" FLANGE-3" MNPT ADPTR POLY
23	1	500204	2"FP FLANGE-2"MNPT POLY
24	1	737873	ROTARY NOZZLE, TEFLON
25	2	737879	EDUCTOR NOZZLE, 3/4MNPT TEEJET
26	1	763431	8" STRAINER BASKET, SOLU TANK
27	1	763571	1000 GAL POLY TANK
28	1	763601	POLY TANK CRADLE WELDMT STS10
29	4	763612	1.625 X 2.375 X 16GA WASHER
30	1	763613	3.250 X 4.250 X 16GA WASHER
31	1	763614	4.500 X 5.500 X 16GA WASHER
32	1	763624	10" TANK LID W/RING ASSY, POLY
33	1	763625	10" TANK LID, POLY
34	1	763626	10" TANK LID RING, POLY
35	2	763630	POLY TANK STRAP ASSY STS10
36	6	900538	1/2UNC X 3 1/2 HEX BOLT FULL
37	6	914008	1/2UNC HEX STOVER NUT
38	1	763621	SOLU HOSE SUPP, POLY TANK STS10
39	2	470321	BALER BELT, 4.00 X 67.00 2-PLY
40	4	482016	SPRING, 1.40 X 3.00 COMPRN
41	4	900416	3/4UNC X 6 1/2 HEX BOLT
42	4	914012	3/4UNC HEX STOVER NUT
43	8	920006	3/4 SAE FLAT WASHER
44	2	914002	5/16UNC HEX STOVER NUT
45	2	900064	5/16UNC X 3/4 HEX CLAMP
46	3	520145	356 T-BOLT HOSE CLAMP SS
47	1	690731	SOLU TUBE, 3.00 S.S. SIDE FILL
48	1	520141	2.31/2.62 T-BOLT HOSE CLAMP SS
49	1	504850	CPVC PIPE NIPPLE .75NPT-24.00
50	1	601574	HOSE, 3 X 36 POLY HELIX EPDM
51	1	601575	HOSE, 3 X 160 POLY HELIX EPDM
52	1	601506	HOSE, 3 X 74 POLY HELIX EPDM
53	1	601573	HOSE, 2 X 48 2F-1W EPDM

NOTE: ITEMS (*) ARE USED WITH THE SIDE FILL OPTION.

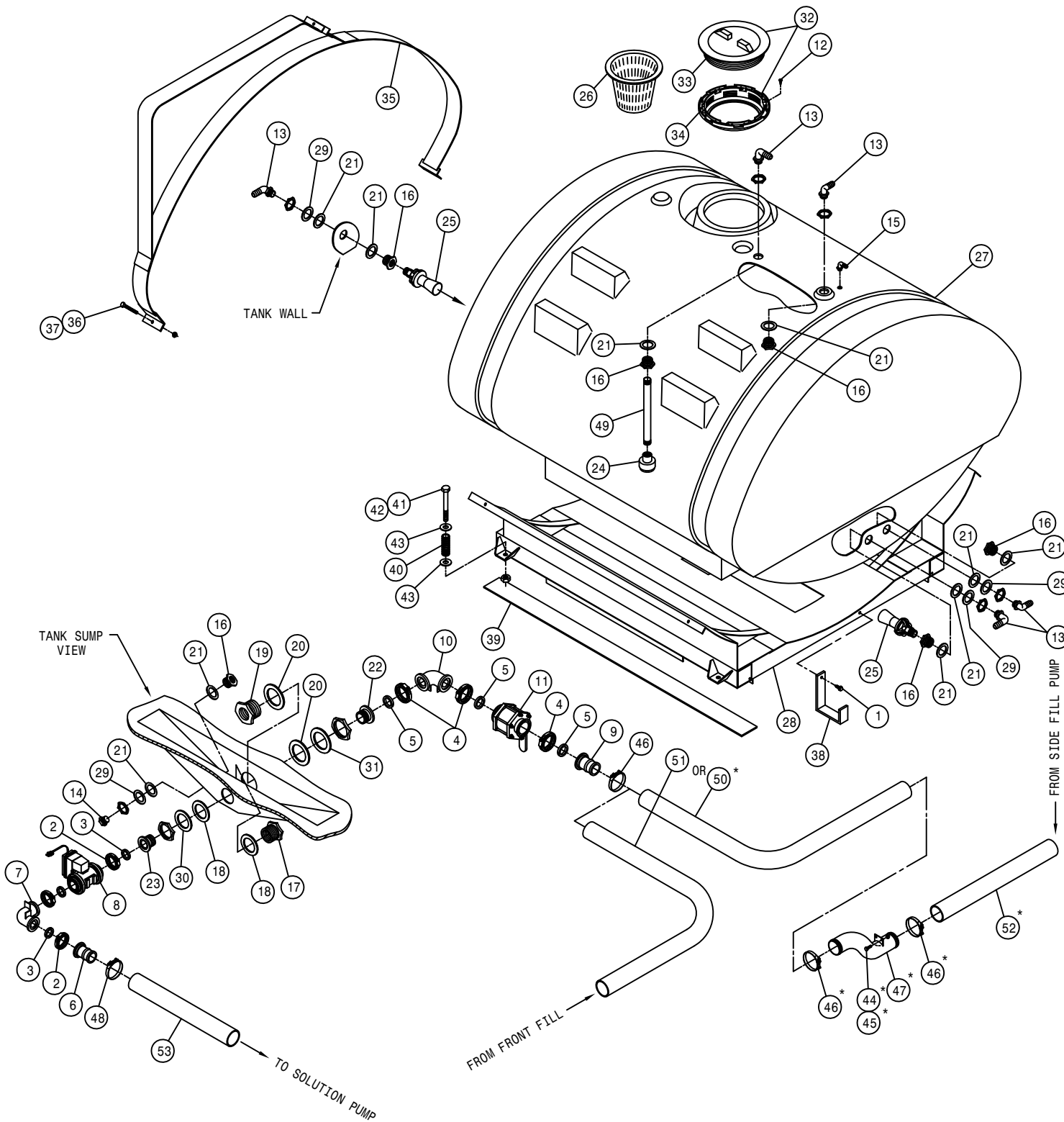

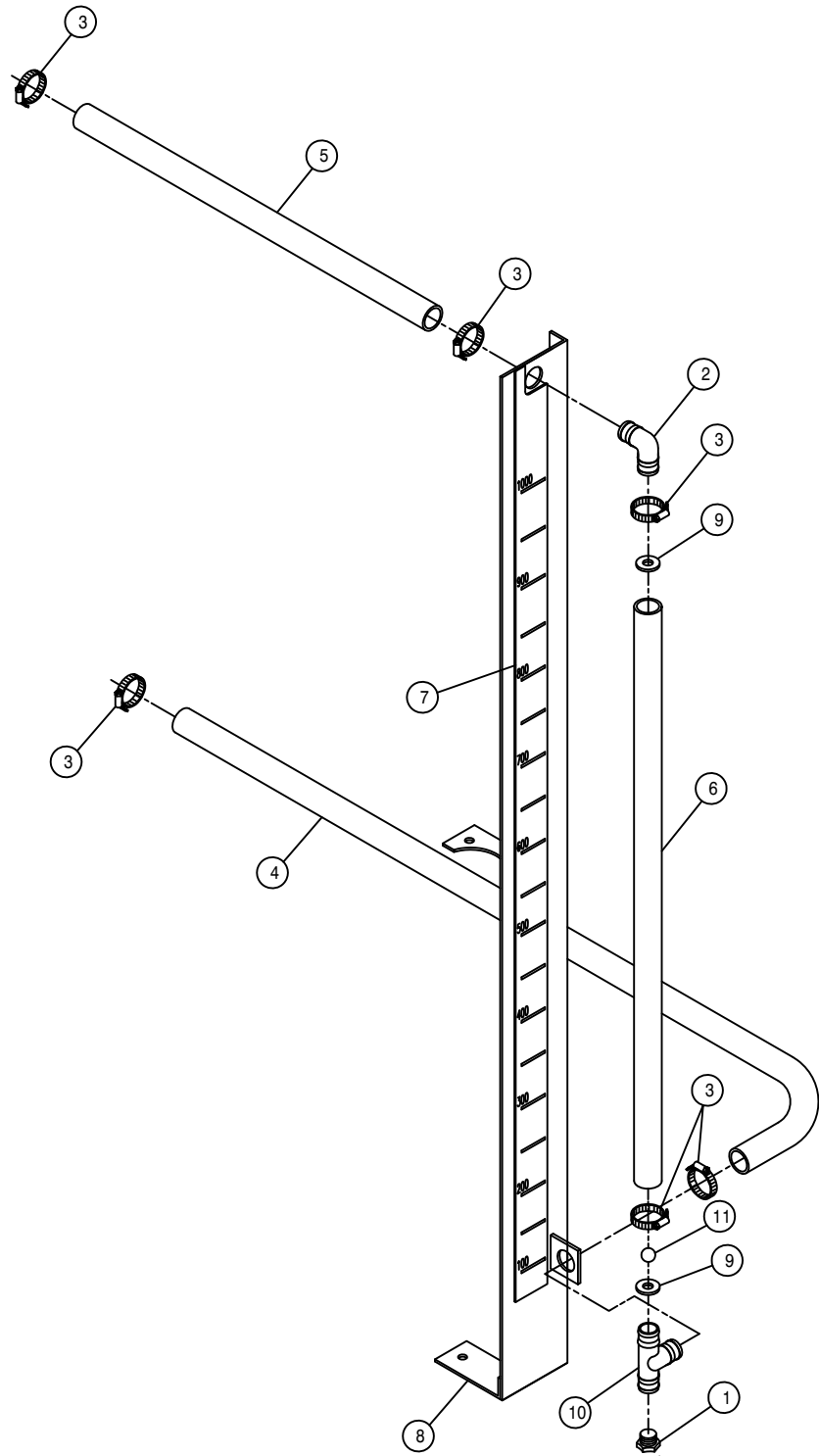

SIGHT GAGE ASSEMBLY

DET.	QTY	PART NO.	DESCRIPTION
1	1	500062	1/2"NPT PIPE PLUG, POLY
2	1	500109	1.00-90-1.00 HOSE BARB, POLY
3	6	520090	HOSE CLAMP NO 16 STAINLESS
4	1	601579	HOSE, 1" X 28 CLEAR VINYL
5	1	601559	HOSE, 1" X 36 CLEAR VINYL
6	1	601580	HOSE, 1" X 47 CLEAR VINYL
7	1	650123	DECAL, SIGHT GAGE, POLY STS10
8	1	763641	SIGHT GAGE WELD,POLY STS10 03
9	2	763620	SS SIGHT GAGE WASHER STS10
10	1	763622	SIGHT GAGE TEE, POLY TNK STS10
11	1	763623	GREEN POLYPROPYLENE BALL .750"

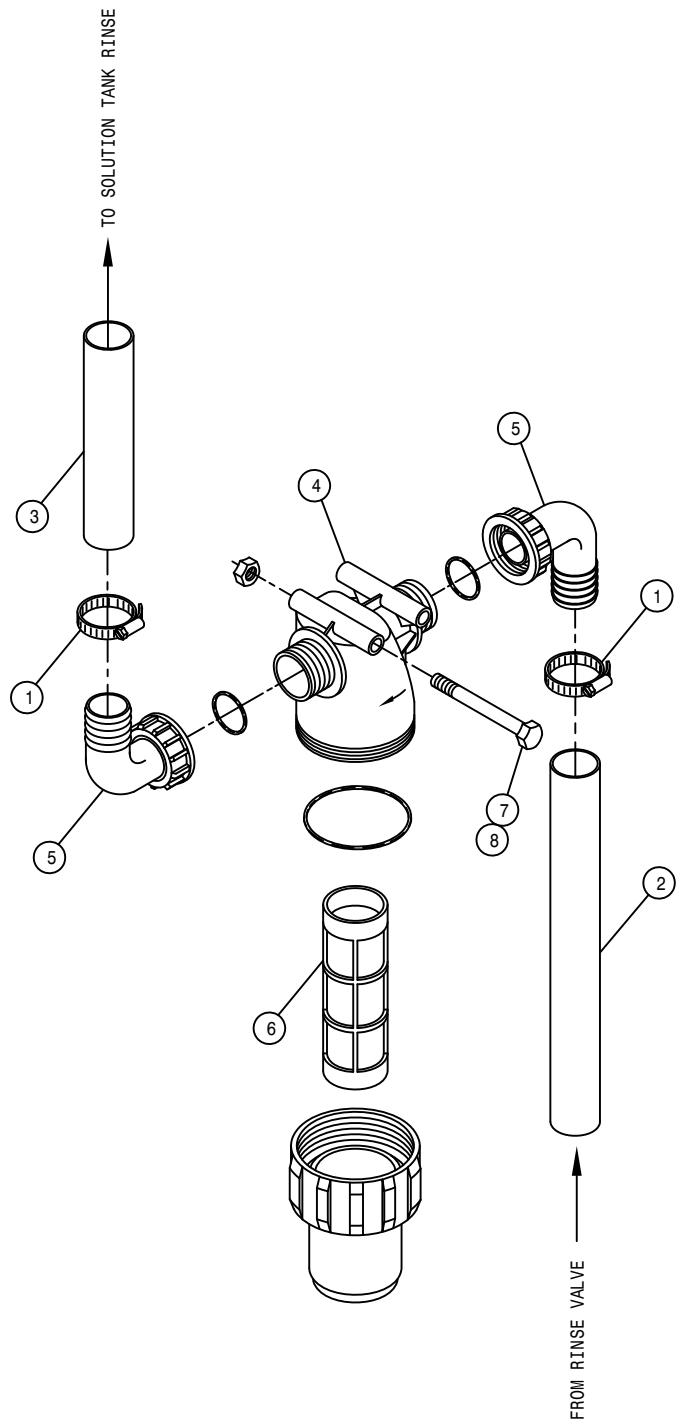

RINSE STRAINER ASSEMBLY

DET.	QTY	PART NO.	DESCRIPTION
1	2	520090	HOSE CLAMP NO 16 STAINLESS
2	1	601588	HOSE, 1 X 28 1BR BLK EPDM
3	1	601589	HOSE, 1 X 80 1BR BLK EPDM
4	1	690071	LINE STRAINER,32 MESH,150PSI
5	2	690072	1"-90D HOSE BARB KIT,STRAINER
6	1	690073	SCREEN,32 MESH,STRANER 690071
7	2	900073	5/16UNC X 3 1/4 HEX BOLT
8	2	470113	5/16UNC HEX FLANGE LOCK NUT

SOLUTION PUMP ASSEMBLY

DET. QTY PART NO. DESCRIPTION

- 1 1 500024 1"NPT-90-1"HOSE BARB, POLY
- 2 1 500103 1/8NPT-90-1/4 HOSE BARB,NYLON
- 3 1 500153 2" FLANGE-90-1 1/2 HBARB POLY
- 4 7 500158 1 1/2" GASKET FOR 2" FLANGE
- 5 12 500160 2" FLANGE CLAMP, S.S.
- 6 5 500189 2" FLANGE-90-1" HOSE BARB POLY
- 7 7 500194 2"FP FLANGE CLAMP, S.S.
- 8 7 500195 2"FP FLANGE GASKET EPDM
- 9 2 500196 2"FP FLANGE-2" HOSE BARB POLY
- 10 2 500199 2"FP FLANGE-2"FLANGE REDU POLY
- 11 1 500203 2"FP FLANGE CROSS POLY
- 12 1 500205 2"FP FLANGE-2"MNPT ADPTR S.S.
- 13 1 500207 2"FP FLANGE TEE POLY
- 14 1 500227 2" FP FLNG-1 1/2"MNPT ADPTR SS
- 15 1 500228 2"FP FLANGE PLUG W/1"FNPT POLY
- 16 8 520090 HOSE CLAMP NO 16 STAINLESS
- 17 1 601531 HOSE, 1 X 15 1BR BLK EPDM
- 18 1 611127 1 1/16MJIC-1 1/16MOR ADPTR
- 19 1 616188 10-451TC-12FJX90-12FJX-19 H/A
- 20 1 618191 1 1/16MJ-90-1 1/16FJ SWIV LBO
- 21 2 618248 1 1/16MJIC-90-1 1/16MOR LBO
- 22 2 618273 1 1/16MJIC-1/2MNPT ADPTR
- 23 1 690666 VALVE HYD CTRL,30GPM RAVEN
- 24 1 690670 HYPRO PUMP, 9305C-HM3CB
- 25 1 690869 SOLUTION PUMP MT WLD, STS 03
- 26 1 696251 VALVE, KZCO C2F-60A-Q-S
- 27 3 696250 VALVE, KZCO C2F60B-M-S
- 28 5 696254 O-RING, KZCO FLANGED VALVES
- 29 2 900008 1/4UNC X 2 1/2 HEX BOLT
- 30 2 900131 3/8UNC X 1 1/2 HEX BOLT
- 31 2 914000 1/4UNC HEX STOVER NUT
- 32 2 914004 3/8UNC HEX STOVER NUT
- 33 1 500176 2" FLANGE CROSS POLY
- 34 1 650125 DECAL,AGIT RATE IND, KZCO VLV
- 35 2 500074 1"NPT-1" HOSE BARB, POLY- 36 1 601590 HOSE, 1 X 6 1BR BLK EPDM
- 37 1 690488 1.00 CHECK VLV, SPRING LOADED
- 38 2 520141 2.31/2.62 T-BOLT HOSE CLAMP SS
- 39 1 520067 HOSE CLAMP NO 28 STAINLESS
- 40 1 520069 HOSE CLAMP NO 6 STAINLESS
- 41 3 900065 5/16UNC X 1" HEX BOLT
- 42 3 914002 5/16UNC HEX STOVER NUT
- 43 1 920001 5/16 SAE FLAT WASHER
- 44 1 500151 2" FLANGE TEE POLY

NOTE: ITEMS MARKED WITH (**) ARE USED WITH THE POLY SOLUTION TANK OPTION.

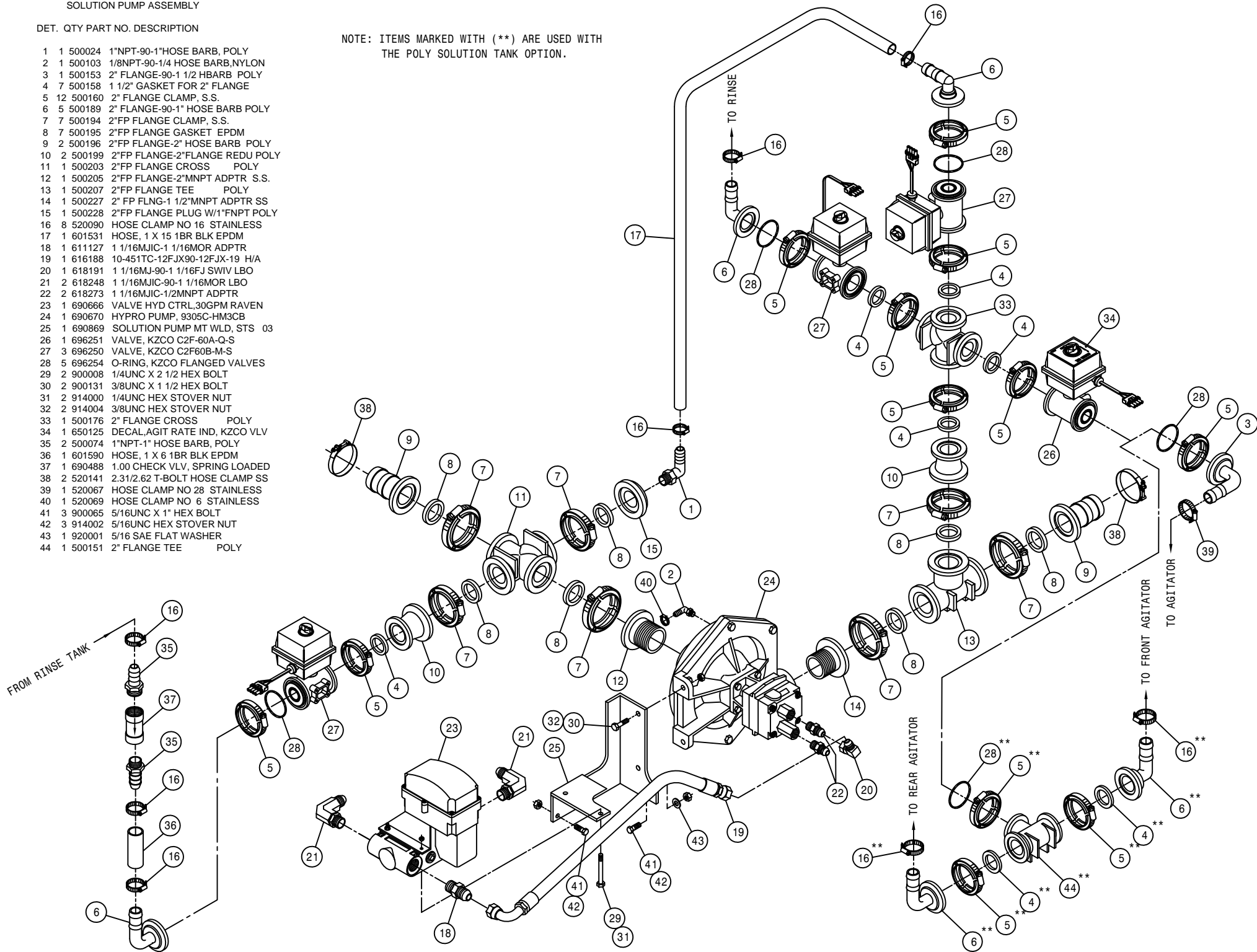

FROM SOLUTION PUMP

TO FLOW METER

LINE STRAINER ASSEMBLY

DET.	QTY	PART NO.	DESCRIPTION
1	1	500154	2" FLANGE-2" HOSE BARB POLY
2	3	500158	1 1/2" GASKET FOR 2" FLANGE
3	3	500160	2" FLANGE CLAMP, S.S.
4	1	500180	2"FLANGE-90-2"FLANGE LBO POLY
5	1	690628	LINE "Y" STRAINER, 2" FLANGE
6	1	690629	50 MESH SCREEN FOR 690628
7	1	500063	1"NPT PIPE PLUG, POLY
8	1	601501	HOSE, 2 X 27 2F-1W EPDM
9	2	520141	2.31/2.62 T-BOLT HOSE CLAMP SS
10	2	473974	.31UNC-2.56ID-3.5 U-BOLT SS
11	4	914002	5/16UNC HEX STOVER NUT
12	1	690630	GASKET FOR 690628
13	1	690631	END CAP FOR 690628
14	2	470322	LANYARD, 8" NYLON LOOP/LOOP
15	1	500152	2" FLANGE-2" MNPT ADPTR POLY
16	1	690279	2.00FNPT-FEM COUPLER,LOCK,POLY
17	1	690392	PLUG FOR 2.00 FEMALE COUPLER
18	1	696224	2.00 HOSE BARB-MALE COUPLER
19	1	690623	CAP FOR 2.00 MALE COUPLER POLY
20	1	500231	2"FP FLANGE GASKET,EXTRA THICK

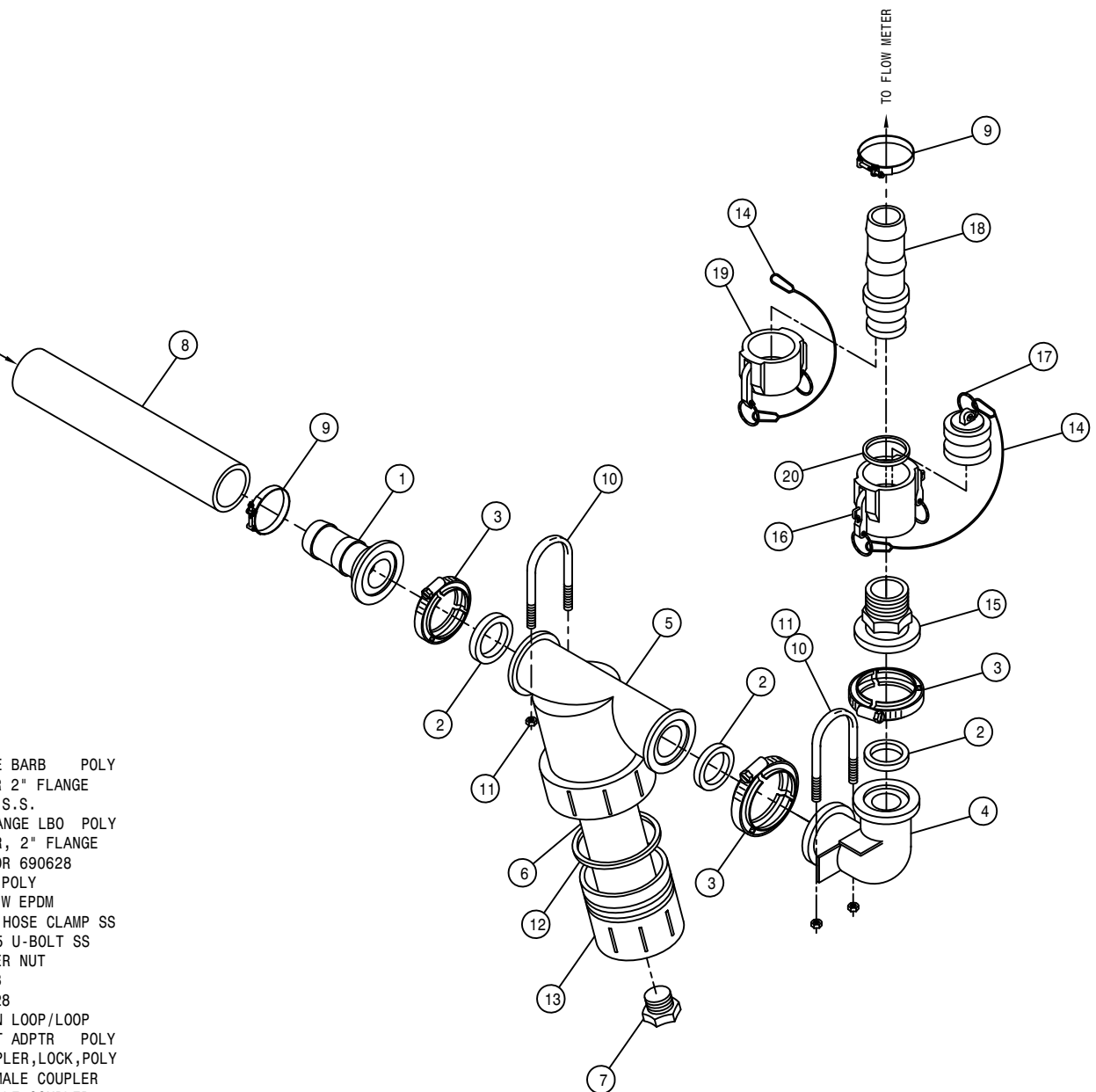

FROM STRAINER

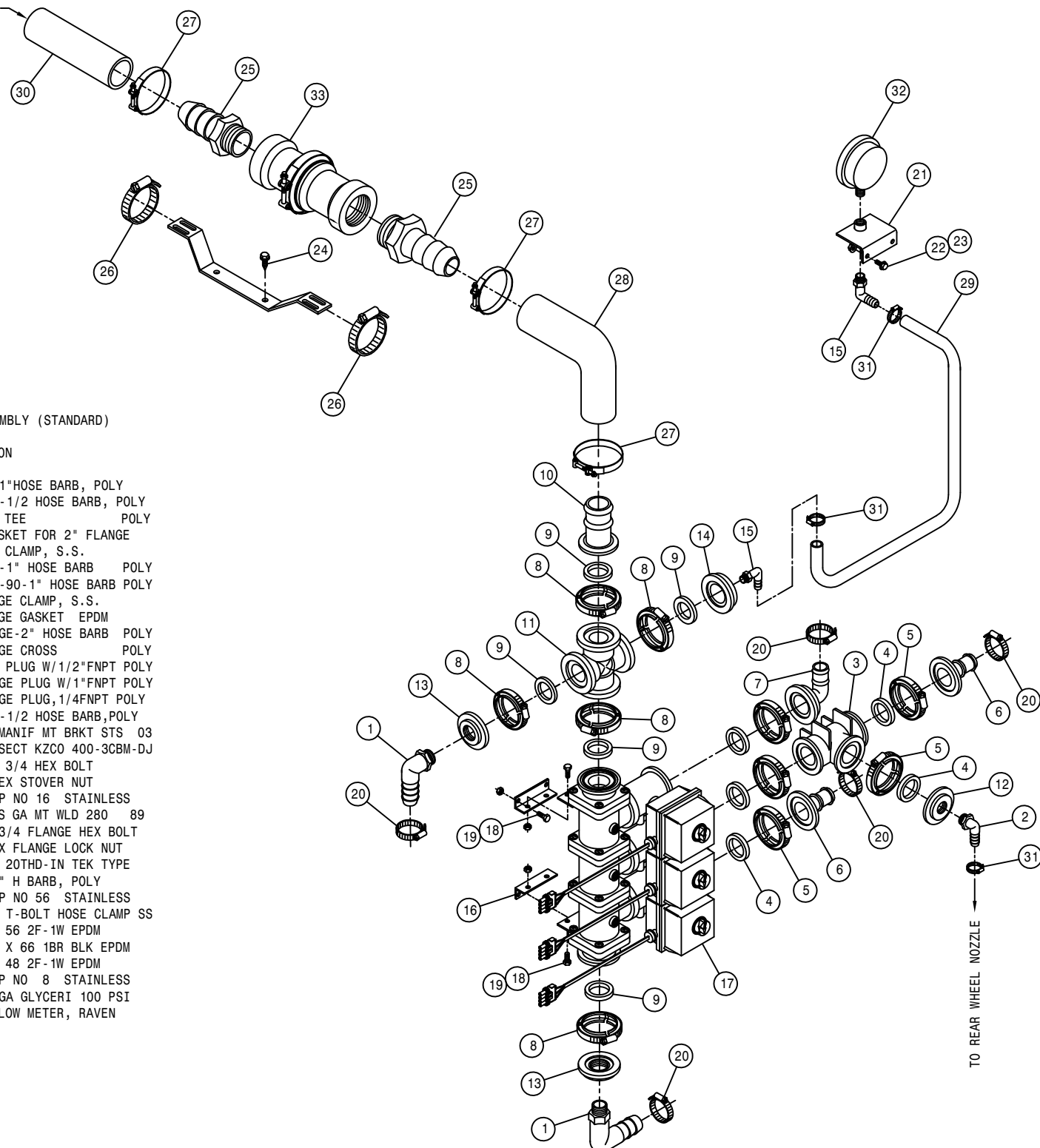

SOLUTION CONTROL VALVE ASSEMBLY (STANDARD)

DET. QTY PART NO. DESCRIPTION

DET.	QTY	PART NO.	DESCRIPTION
1	2	500024	1"NPT-90-1"HOSE BARB, POLY
2	1	500047	1/2NPT-90-1/2 HOSE BARB, POLY
3	1	500151	2" FLANGE TEE POLY
4	5	500158	1 1/2" GASKET FOR 2" FLANGE
5	5	500160	2" FLANGE CLAMP, S.S.
6	2	500172	2" FLANGE-1" HOSE BARB POLY
7	1	500189	2" FLANGE-90-1" HOSE BARB POLY
8	5	500194	2"FP FLANGE CLAMP, S.S.
9	5	500195	2"FP FLANGE GASKET EPDM
10	1	500196	2"FP FLANGE-2" HOSE BARB POLY
11	1	500203	2"FP FLANGE CROSS POLY
12	1	500224	2" FLANGE PLUG W/1/2"FNPT POLY
13	2	500228	2"FP FLANGE PLUG W/1"FNPT POLY
14	1	500229	2"FP FLANGE PLUG,1/4FNPT POLY
15	2	618556	1/4NPT-90-1/2 HOSE BARB,POLY
16	2	690870	SOLU VLV MANIF MT BRKT STS 03
17	1	696253	VALVE, 3 SECT KZCO 400-3CBM-DJ
18	8	900064	5/16UNC X 3/4 HEX BOLT
19	8	914002	5/16UNC HEX STOVER NUT
20	5	520090	HOSE CLAMP NO 16 STAINLESS
21	1	160010	SOLU PRESS GA MT WLD 280 89
22	2	470118	1/4UNC X 3/4 FLANGE HEX BOLT
23	2	470121	1/4UNC HEX FLANGE LOCK NUT
24	2	472349	1/4 X 3/4 20THD-IN TEK TYPE
25	2	500058	2"NPT X 2" H BARB, POLY
26	2	520056	HOSE CLAMP NO 56 STAINLESS
27	3	520141	2.31/2.62 T-BOLT HOSE CLAMP SS
28	1	601502	HOSE, 2 X 56 2F-1W EPDM
29	1	601514	HOSE, 1/2 X 66 1BR BLK EPDM
30	1	601573	HOSE, 2 X 48 2F-1W EPDM
31	3	520070	HOSE CLAMP NO 8 STAINLESS
32	1	690359	PRESSURE GA GLYCERI 100 PSI
33	1	690529	RFM 100 FLOW METER, RAVEN

TO REAR WHEEL NOZZLE

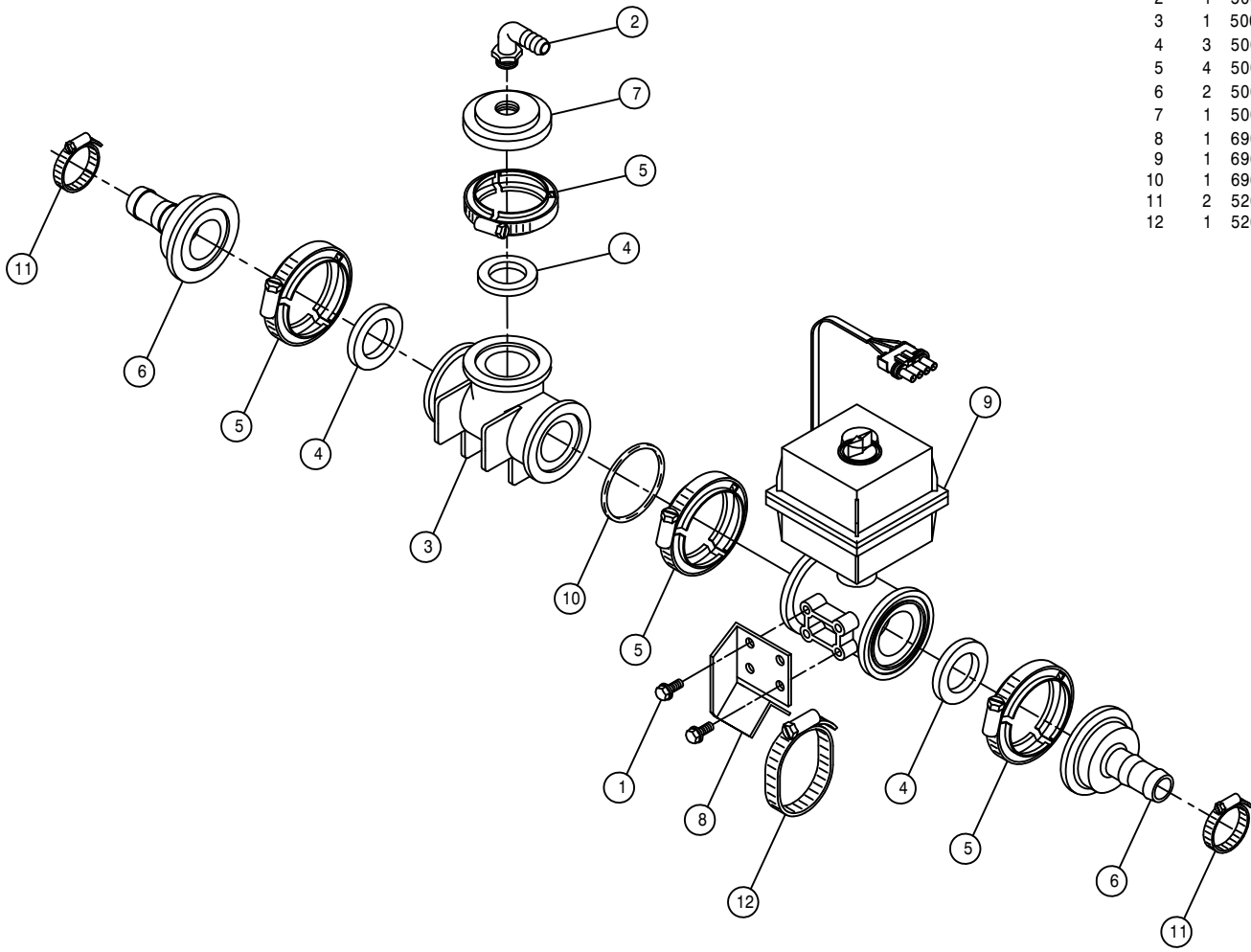

80' -90' SOLUTION VALVE ASSEMBLY (STANDARD)

DET. QTY PART NO. DESCRIPTION

1	2	470122	1/4UNC X 1/2 FLANGE HEX BOLT
2	1	500047	1/2NPT-90-1/2 HOSE BARB, POLY
3	1	500151	2" FLANGE TEE POLY
4	3	500158	1 1/2" GASKET FOR 2" FLANGE
5	4	500160	2" FLANGE CLAMP, S.S.
6	2	500172	2" FLANGE-1" HOSE BARB POLY
7	1	500224	2" FLANGE PLUG W/1/2"FNPT POLY
8	1	690871	80/90 BOOM VLV MT WLD 03
9	1	696250	VALVE, KZCO C2F60B-M-S
10	1	696254	O-RING, KZCO FLANGED VALVES
11	2	520090	HOSE CLAMP NO 16 STAINLESS
12	1	520067	HOSE CLAMP NO 28 STAINLESS

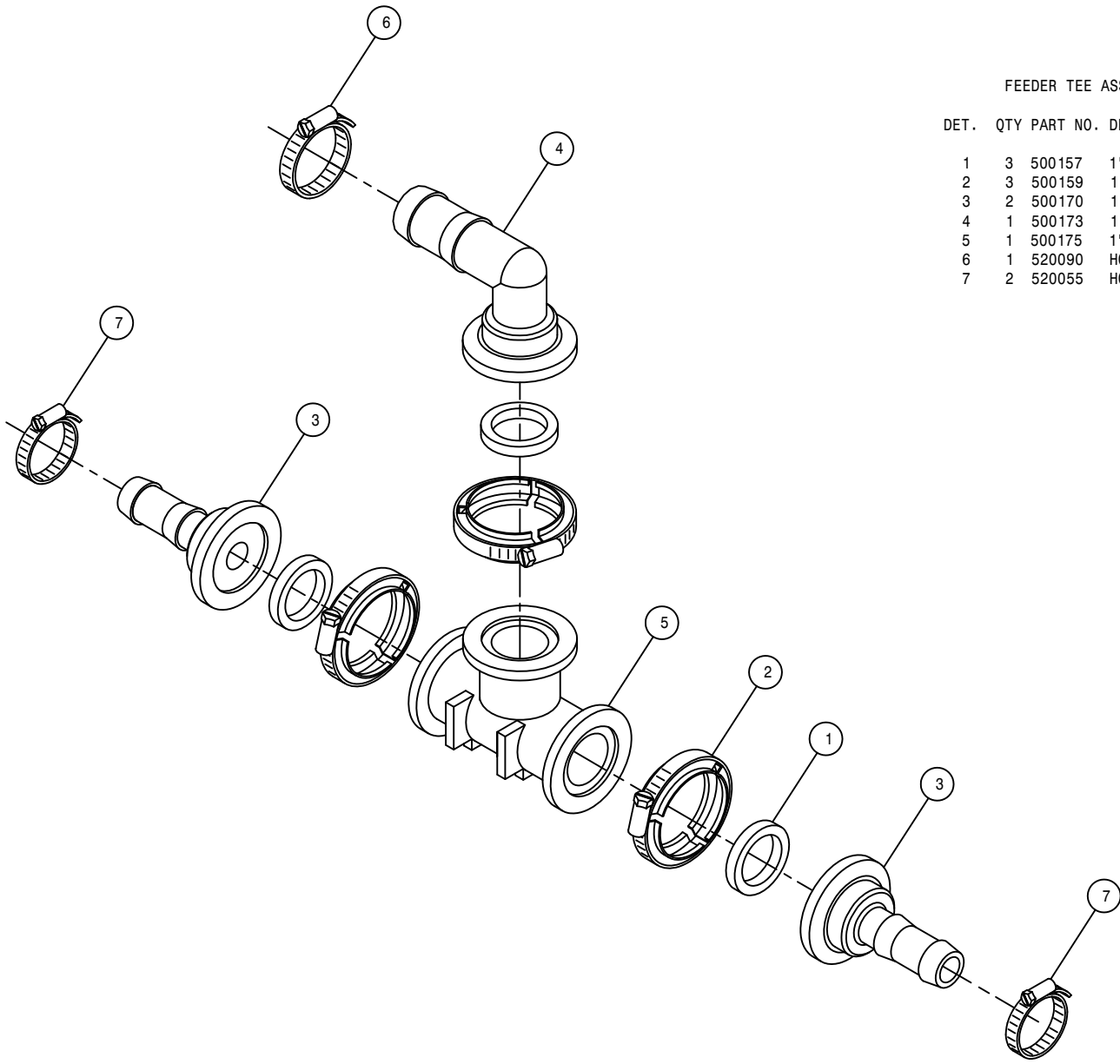

FEEDER TEE ASSEMBLY (STANDARD)

DET.	QTY	PART NO.	DESCRIPTION	
1	3	500157	1" FLANGE GASKET	EPDM
2	3	500159	1" FLANGE CLAMP, S.S.	
3	2	500170	1" FLANGE-3/4" HOSE BARB	POLY
4	1	500173	1" FLANGE-90-1" HOSE BARB	POLY
5	1	500175	1" FLANGE TEE	POLY
6	1	520090	HOSE CLAMP NO 16	STAINLESS
7	2	520055	HOSE CLAMP NO 12	STAINLESS

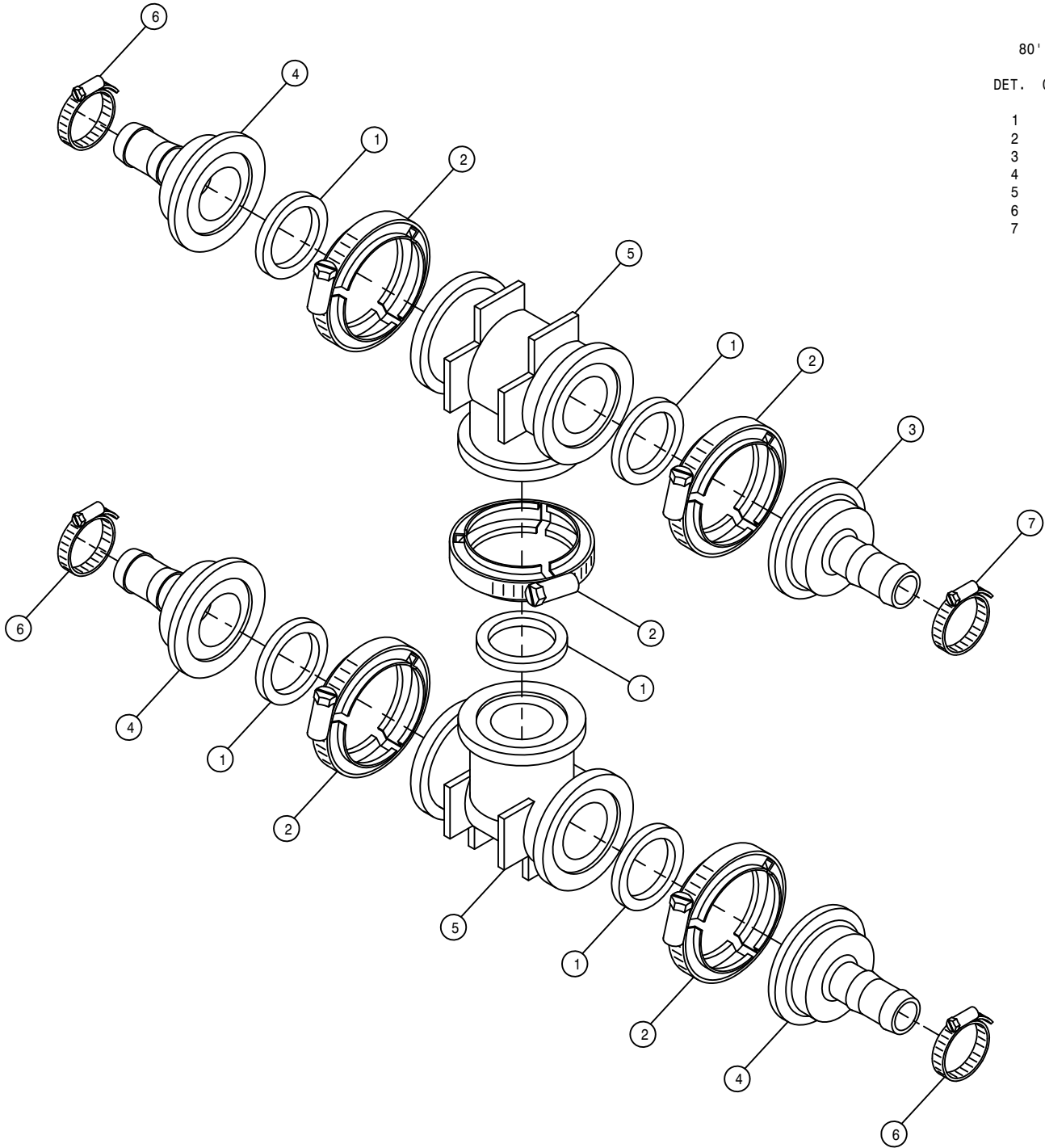

80°-90° FEEDER TEE ASSEMBLY (STANDARD)

DET.	QTY	PART NO.	DESCRIPTION	
1	5	500157	1" FLANGE GASKET	EPDM
2	5	500159	1" FLANGE CLAMP, S.S.	
3	1	500171	1" FLANGE-1" HOSE BARB	POLY
4	3	500170	1" FLANGE-3/4" HOSE BARB	POLY
5	2	500175	1" FLANGE TEE	POLY
6	3	520055	HOSE CLAMP NO 12	STAINLESS
7	1	520090	HOSE CLAMP NO 16	STAINLESS

90° BALL VALVE ASSEMBLY (STANDARD)

DET. QTY PART NO. DESCRIPTION

1	2	500157	1" FLANGE GASKET	EPDM
2	2	500159	1" FLANGE CLAMP, S.S.	
3	1	500170	1" FLANGE-3/4" HOSE BARB POLY	
4	1	701191	1" SOLU VLV MT WLD	
5	1	696147	BALL VLV, 1" FLANGE	
6	1	520085	HOSE CLAMP NO 24 STAINLESS	
7	2	520055	HOSE CLAMP NO 12 STAINLESS	
8	1	500185	1" FLANGE-90-3/4" HOSE BARB POLY	

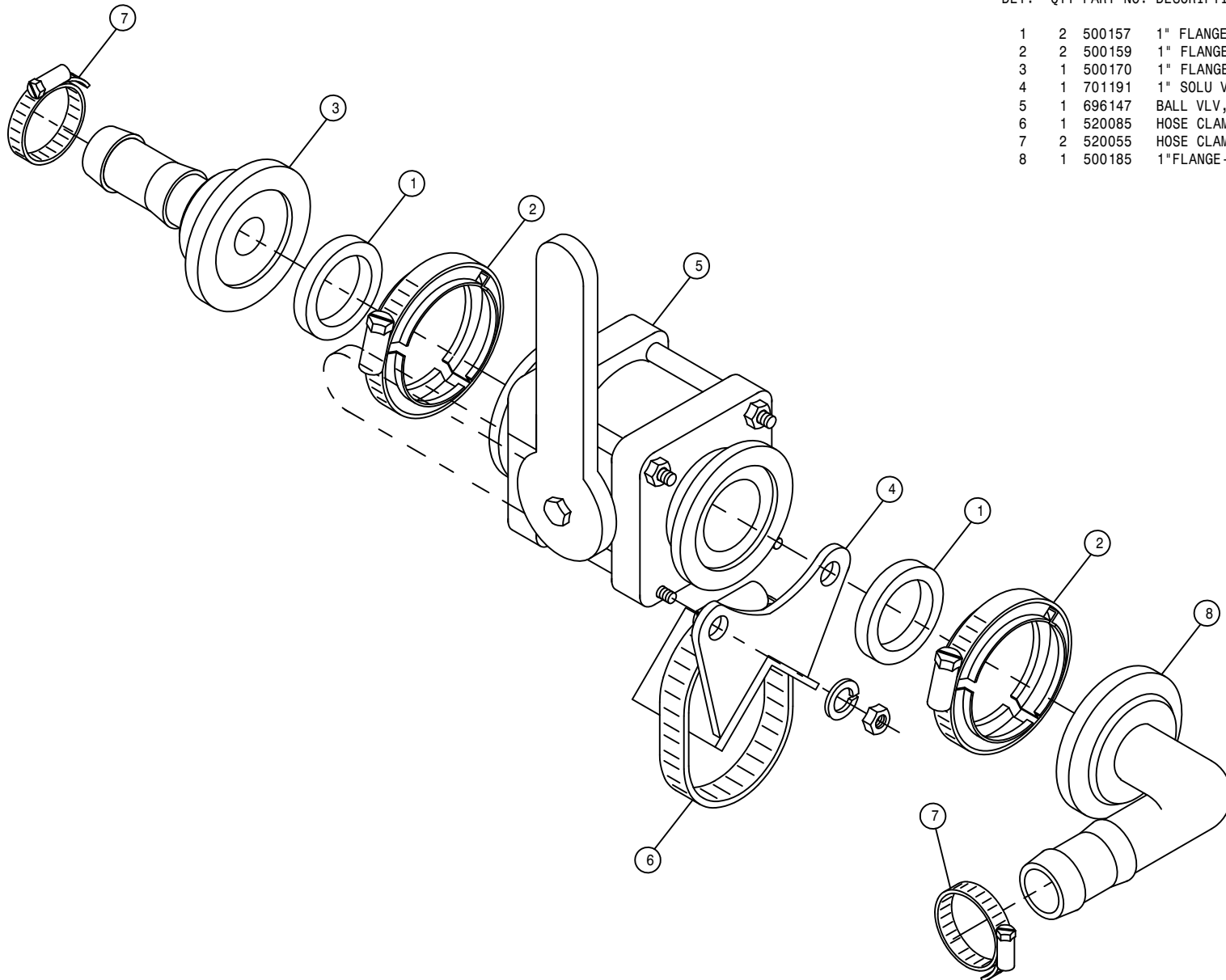

FROM STRAINER

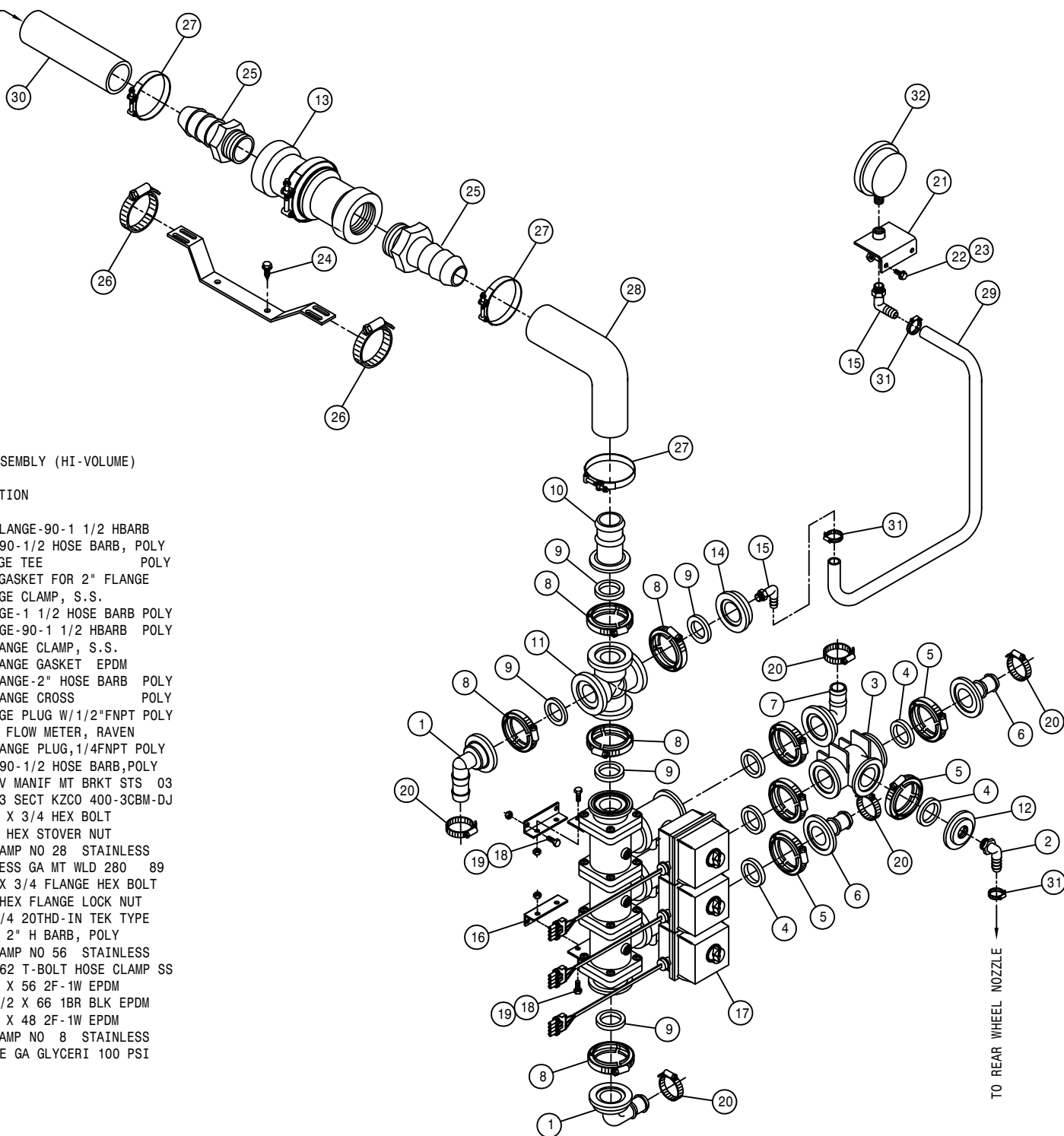

SOLUTION CONTROL VALVE ASSEMBLY (HI-VOLUME)

DET. QTY PART NO. DESCRIPTION

1	2	500197	2" FP FLANGE-90-1 1/2 HBARB
2	1	500047	1/2NPT-90-1/2 HOSE BARB, POLY
3	1	500151	2" FLANGE TEE POLY
4	5	500158	1 1/2" GASKET FOR 2" FLANGE
5	5	500160	2" FLANGE CLAMP, S.S.
6	2	500162	2" FLANGE-1 1/2 HOSE BARB POLY
7	1	500153	2" FLANGE-90-1 1/2 HBARB POLY
8	5	500194	2"FP FLANGE CLAMP, S.S.
9	5	500195	2"FP FLANGE GASKET EPDM
10	1	500196	2"FP FLANGE-2" HOSE BARB POLY
11	1	500203	2"FP FLANGE CROSS POLY
12	1	500224	2" FLANGE PLUG W/1/2"FNPT POLY
13	1	690529	RFM 100 FLOW METER, RAVEN
14	1	500229	2"FP FLANGE PLUG,1/4FNPT POLY
15	2	618556	1/4NPT-90-1/2 HOSE BARB,POLY
16	2	690870	SOLU VLV MANIF MT BRKT STS 03
17	1	696253	VALVE, 3 SECT KZCO 400-3CBM-DJ
18	8	900064	5/16UNC X 3/4 HEX BOLT
19	8	914002	5/16UNC HEX STOVER NUT
20	5	520067	HOSE CLAMP NO 28 STAINLESS
21	1	160010	SOLU PRESS GA MT WLD 280 89
22	2	470118	1/4UNC X 3/4 FLANGE HEX BOLT
23	2	470121	1/4UNC HEX FLANGE LOCK NUT
24	2	472349	1/4 X 3/4 20THD-IN TEK TYPE
25	2	500058	2"NPT X 2" H BARB, POLY
26	2	520056	HOSE CLAMP NO 56 STAINLESS
27	3	520141	2.31/2.62 T-BOLT HOSE CLAMP SS
28	1	601502	HOSE, 2 X 56 2F-1W EPDM
29	1	601514	HOSE, 1/2 X 66 1BR BLK EPDM
30	1	601573	HOSE, 2 X 48 2F-1W EPDM
31	3	520070	HOSE CLAMP NO 8 STAINLESS
32	1	690359	PRESSURE GA GLYCERI 100 PSI

TO REAR WHEEL NOZZLE

80' -90' SOLUTION VALVE ASSEMBLY (HI-VOLUME)

DET. QTY PART NO. DESCRIPTION

DET.	QTY	PART NO.	DESCRIPTION
1	2	470122	1/4UNC X 1/2 FLANGE HEX BOLT
2	1	500047	1/2NPT-90-1/2 HOSE BARB, POLY
3	1	500151	2" FLANGE TEE POLY
4	3	500158	1 1/2" GASKET FOR 2" FLANGE
5	4	500160	2" FLANGE CLAMP, S.S.
6	2	500162	2" FLANGE-1 1/2 HOSE BARB POLY
7	1	500224	2" FLANGE PLUG W/1/2"FNPT POLY
8	1	690871	80/90 BOOM VLV MT WLD 03
9	1	696250	VALVE, KZCO C2F60B-M-S
10	1	696254	O-RING, KZCO FLANGED VALVES
11	1	520133	1.81/2.06 T-BOLT HOSE CLAMP SS
12	2	520067	HOSE CLAMP NO 28 STAINLESS

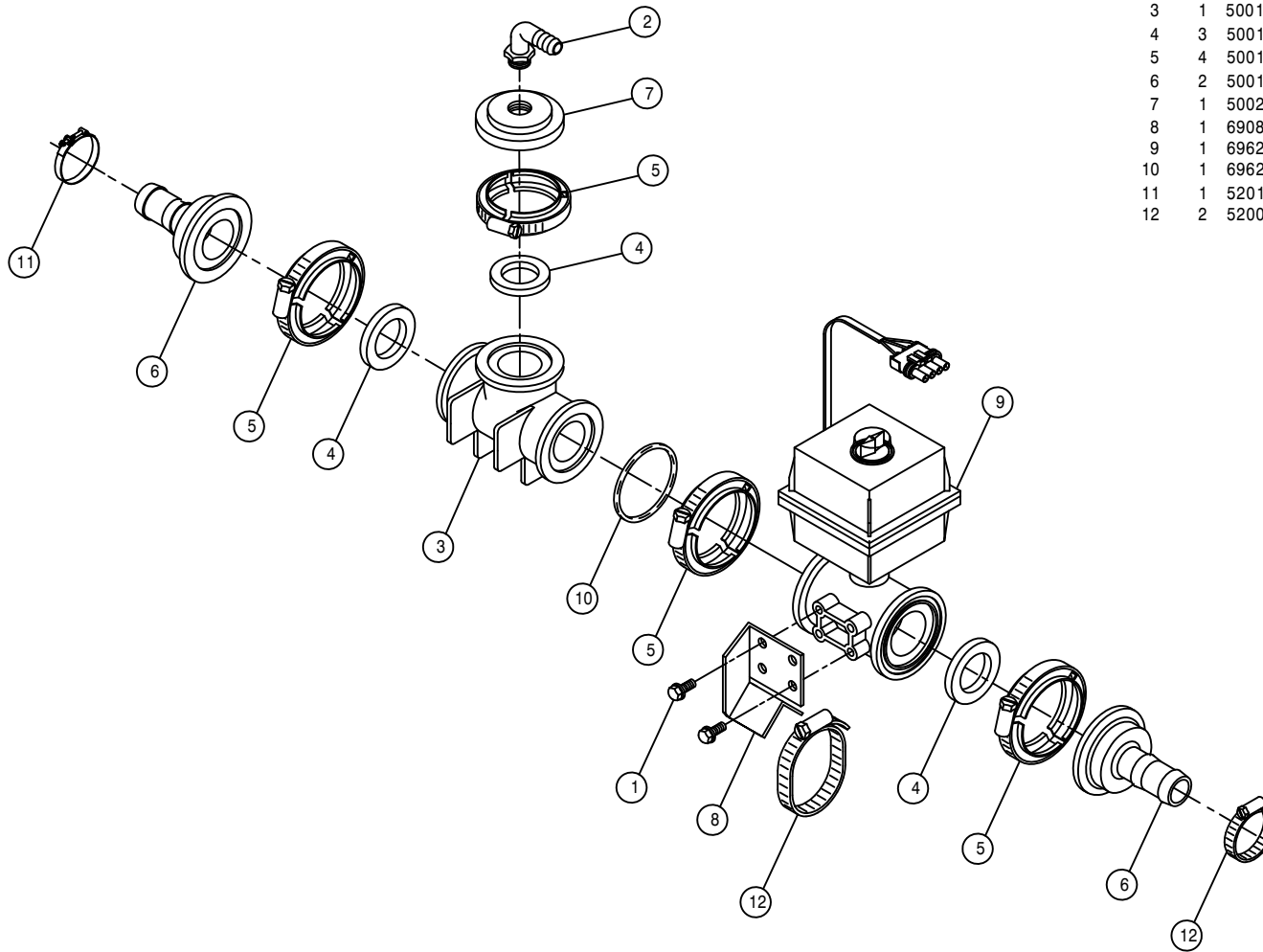

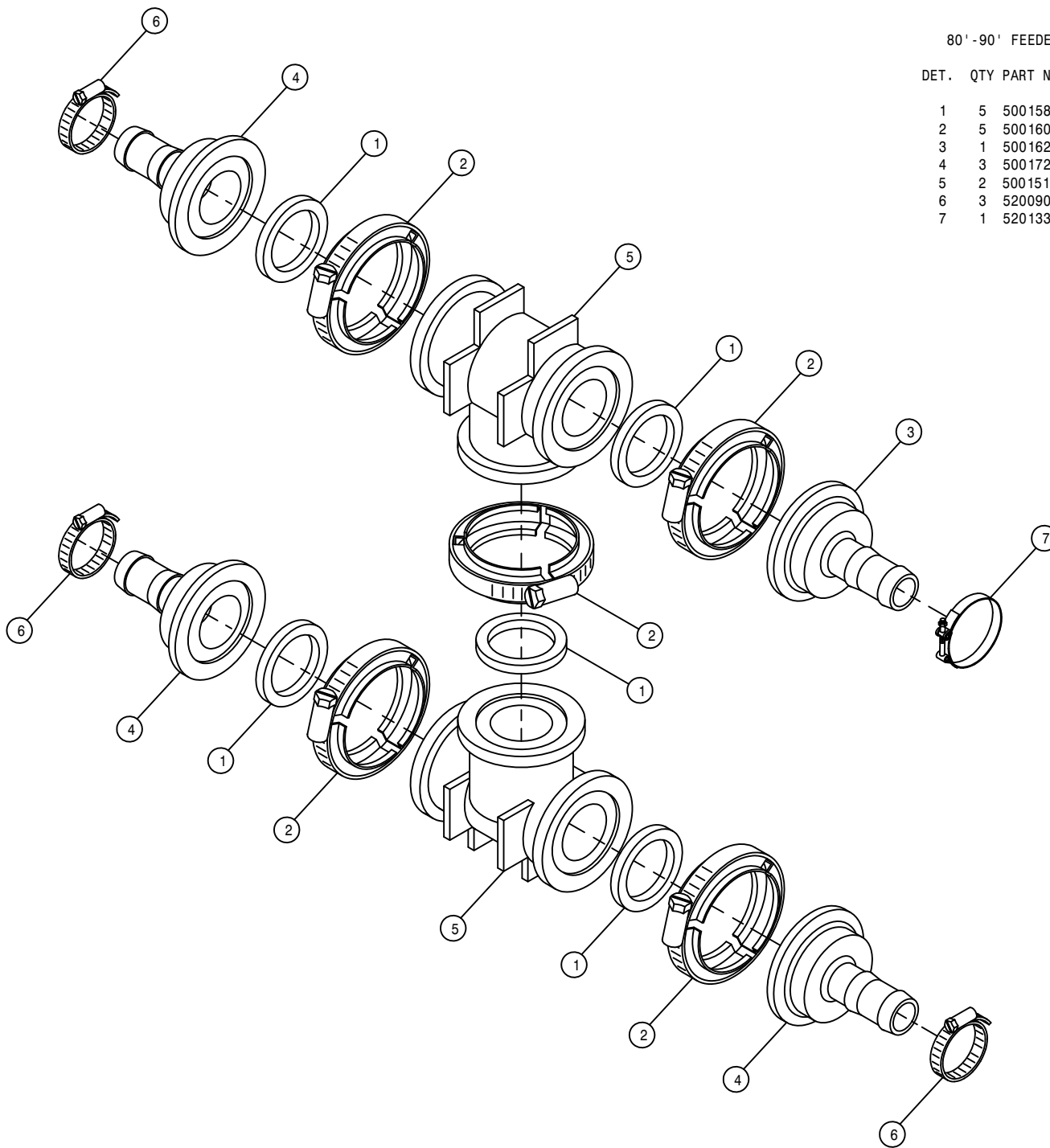

80' -90' FEEDER TEE ASSEMBLY (HI-VOLUME)

DET. QTY PART NO. DESCRIPTION

1	5	500158	1 1/2" GASKET FOR 2" FLANGE
2	5	500160	2" FLANGE CLAMP, S.S.
3	1	500162	2" FLANGE-1 1/2 HOSE BARB POLY
4	3	500172	2" FLANGE-1" HOSE BARB POLY
5	2	500151	2" FLANGE TEE POLY
6	3	520090	HOSE CLAMP NO 16 STAINLESS
7	1	520133	1.81/2.06 T-BOLT HOSE CLAMP SS

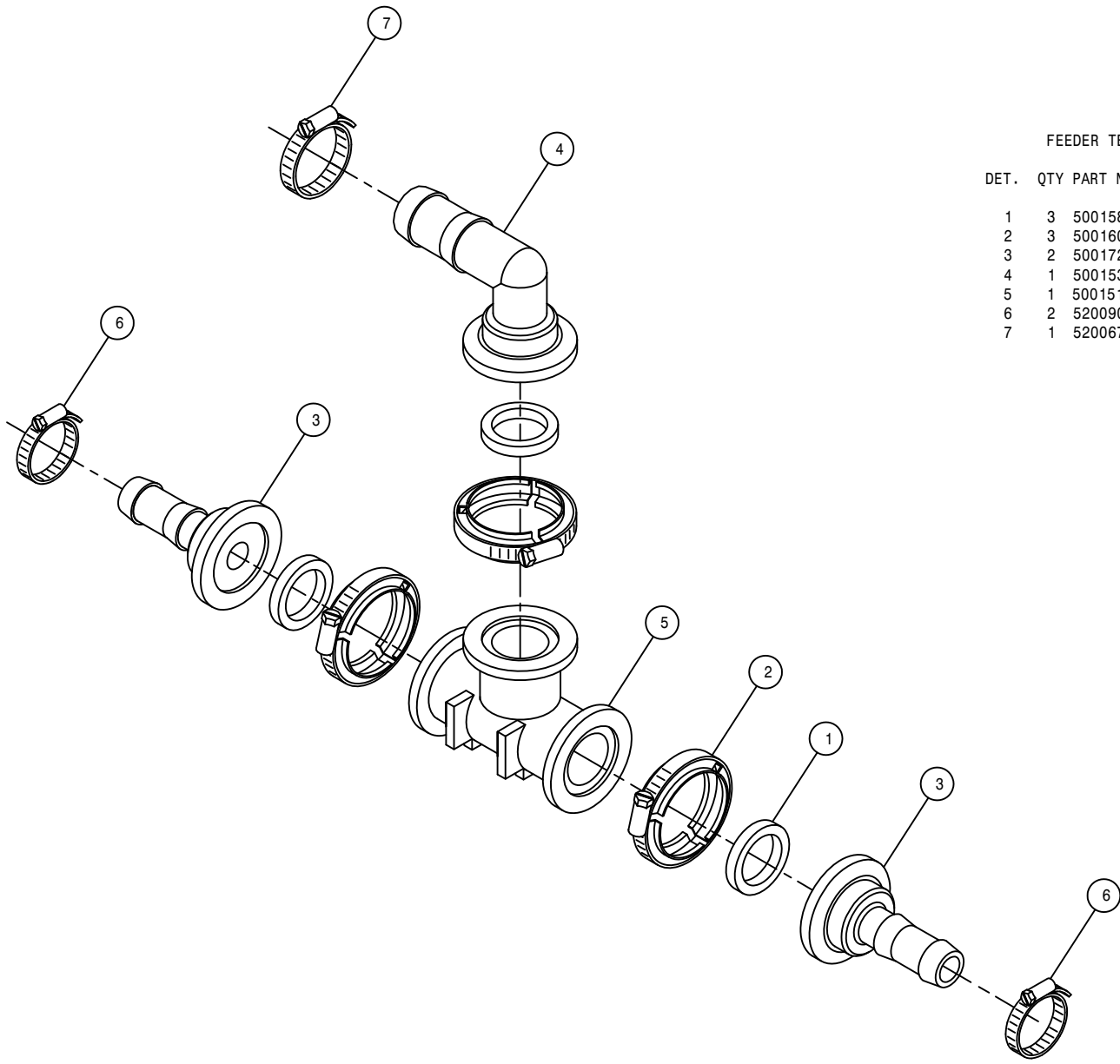

FEEDER TEE ASSEMBLY (HI-VOLUME)

DET. QTY PART NO. DESCRIPTION

1	3	500158	1 1/2" GASKET FOR 2" FLANGE
2	3	500160	2" FLANGE CLAMP, S.S.
3	2	500172	2" FLANGE-1" HOSE BARB POLY
4	1	500153	2" FLANGE-90-1 1/2 HBARB POLY
5	1	500151	2" FLANGE TEE POLY
6	2	520090	HOSE CLAMP NO 16 STAINLESS
7	1	520067	HOSE CLAMP NO 28 STAINLESS

90' BALL VALVE ASSEMBLY (HI-VOLUME)

DET. QTY PART NO. DESCRIPTION

DET.	QTY	PART NO.	DESCRIPTION	
1	2	500157	1" FLANGE GASKET	EPDM
2	2	500159	1" FLANGE CLAMP, S.S.	
3	1	500171	1" FLANGE-1" HOSE BARB	POLY
4	1	701191	1" SOLU VLV MT WLD	
5	1	696147	BALL VLV, 1" FLANGE	
6	1	520085	HOSE CLAMP NO 24	STAINLESS
7	2	520090	HOSE CLAMP NO 16	STAINLESS
8	1	500173	1" FLANGE-90-1" HOSE BARB	POLY

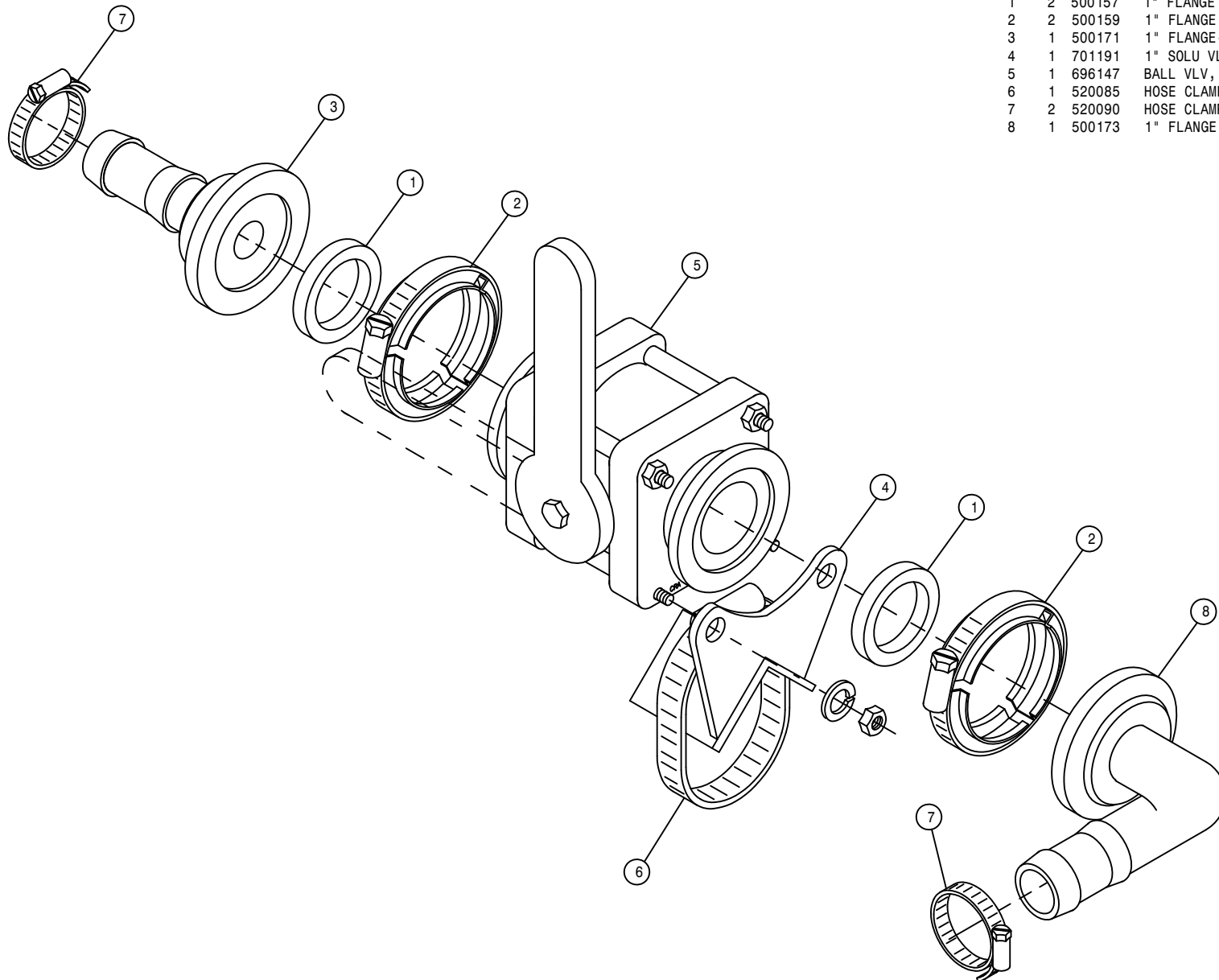

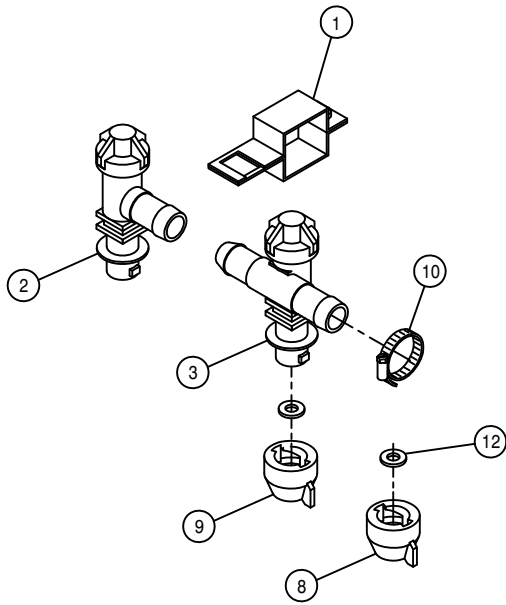

STANDARD SINGLE TIP SPACING

BOOM NOZZLE BODY

DET. QTY PART NO. DESCRIPTION

DET.	QTY	PART NO.	DESCRIPTION
1	3	737817	NOZL MT CLMP, 1.00 SQ SS, Q-TJET
2	1	737829	QUICK TJET LBO, 1-TIP BODY .75
3	1	737830	QUICK TJET TEE, 1-TIP BODY .75
4	1	737833	QUICK TJET LBO, 3-TIP BODY .75
5	1	737834	QUICK TJET TEE, 3-TIP BODY .75
6	1	737900	QUICK TJET LBO, 3-TIP BODY 1.00
7	1	737901	QUICK TJET TEE, 3-TIP BODY 1.00
8	3	737825	QUICK SHUT-OFF CAP
9	3	737822	CAP SET, YELLOW QUICK TEEJET
10	2	520055	HOSE CLAMP NO 12 STAINLESS
11	1	520090	HOSE CLAMP NO 16 STAINLESS
12	6	737824	QUICK TEEJET SEAT GASKET

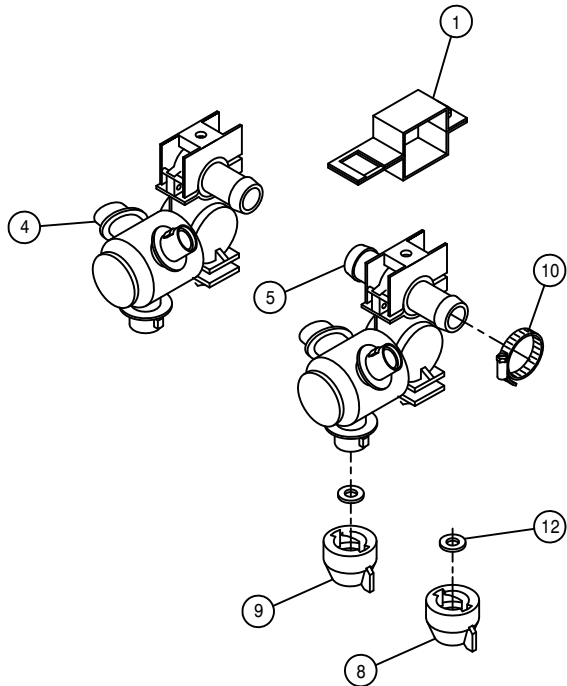

STANDARD TRIPLE TIP SPACING

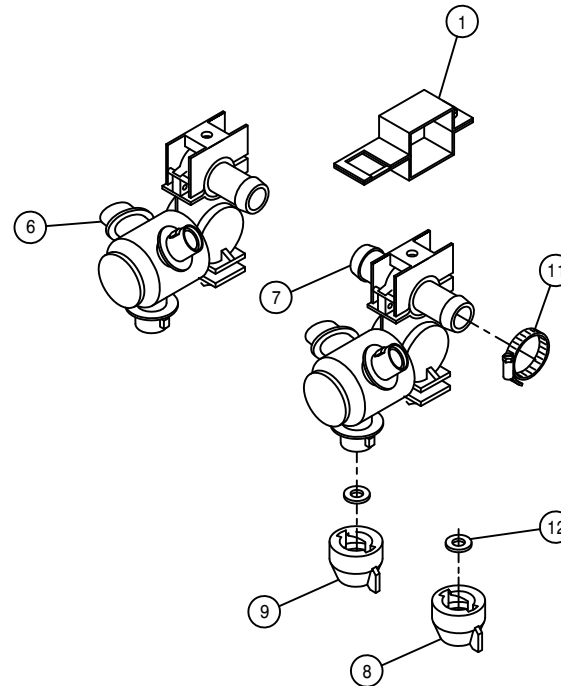

HI-VOLUME TRIPLE TIP SPACING

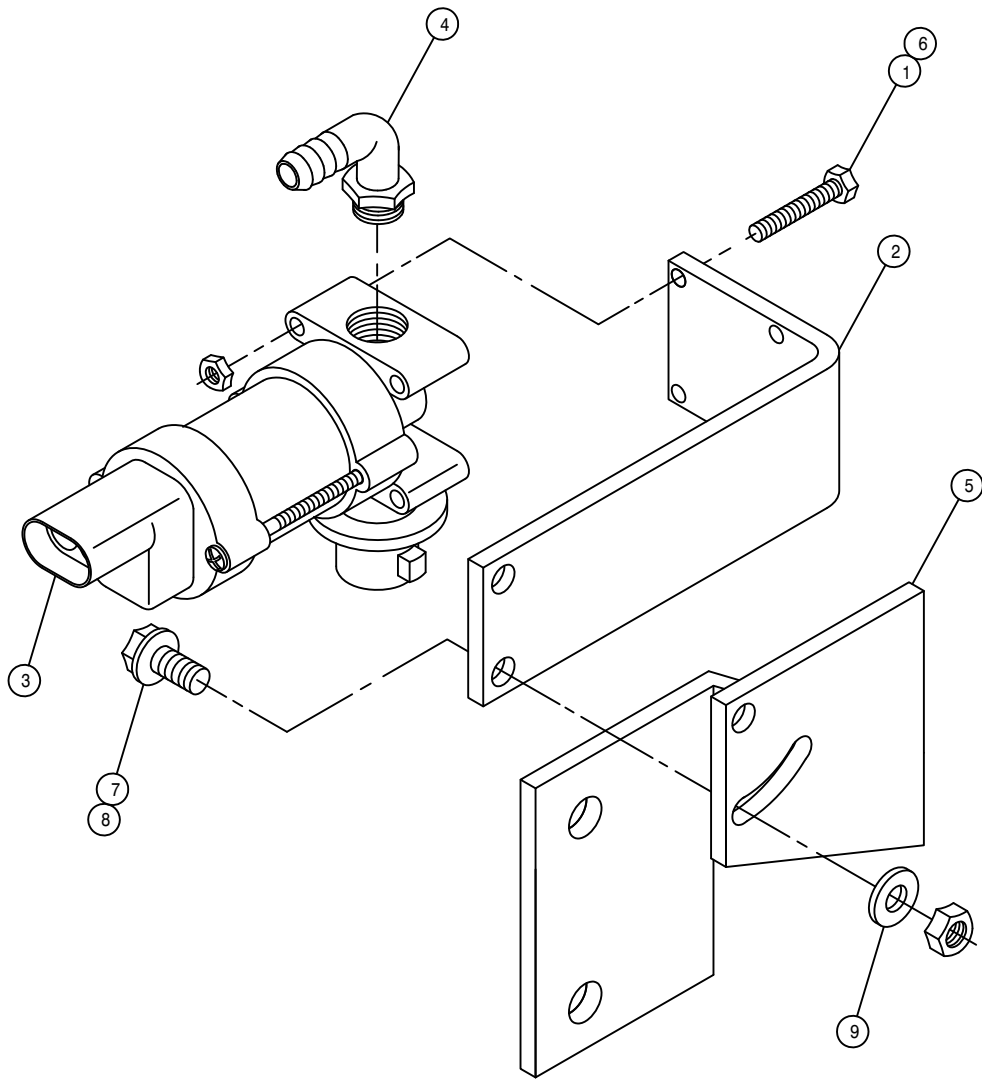

RH FENCE ROW NOZZLE ASSEMBLY

DET. QTY PART NO. DESCRIPTION

1	4	473993	6-32 X 1 1/4 HH MACH SCR
2	1	737906	FENCE ROW NOZL BRKT
3	1	737875	NOZZLE BODY VALVE, 12VDC
4	1	618556	1/4NPT-90-1/2 HOSE BARB,POLY
5	1	737907	RH FENCE ROW TIP BRKT MT
6	4	910022	6-32 HEX NUT
7	2	470118	1/4UNC X 3/4 FLANGE HEX BOLT
8	2	914000	1/4UNC HEX STOVER NUT
9	1	920000	1/4 SAE FLAT WASHER

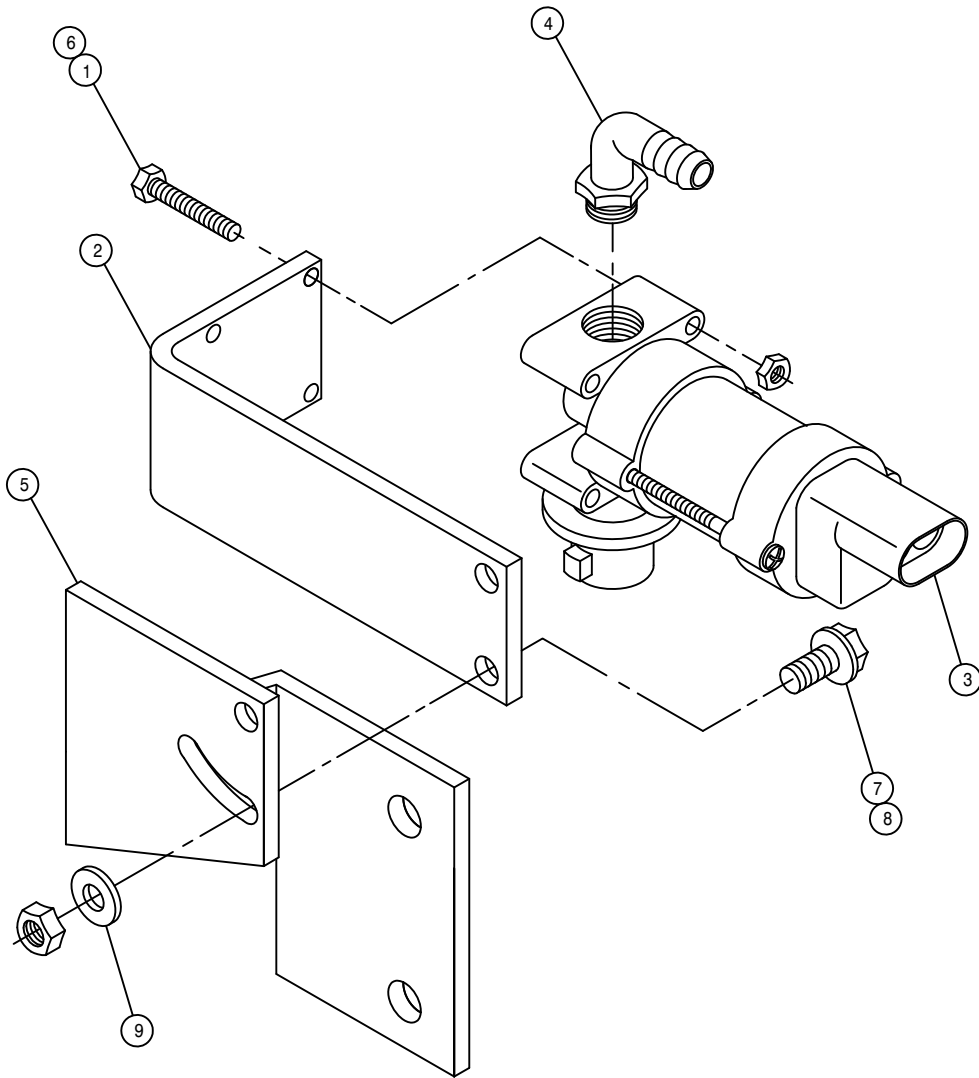

LH FENCE ROW NOZZLE ASSEMBLY

DET. QTY PART NO. DESCRIPTION

1	4	473993	6-32 X 1 1/4 HH MACH SCR
2	1	737906	FENCE ROW NOZL BRKT
3	1	737875	NOZZLE BODY VALVE, 12VDC
4	1	618556	1/4NPT-90-1/2 HOSE BARB,POLY
5	1	737908	LH FENCE ROW TIP BRKT MT
6	4	910022	6-32 HEX NUT
7	2	470118	1/4UNC X 3/4 FLANGE HEX BOLT
8	2	914000	1/4UNC HEX STOVER NUT
9	1	920000	1/4 SAE FLAT WASHER

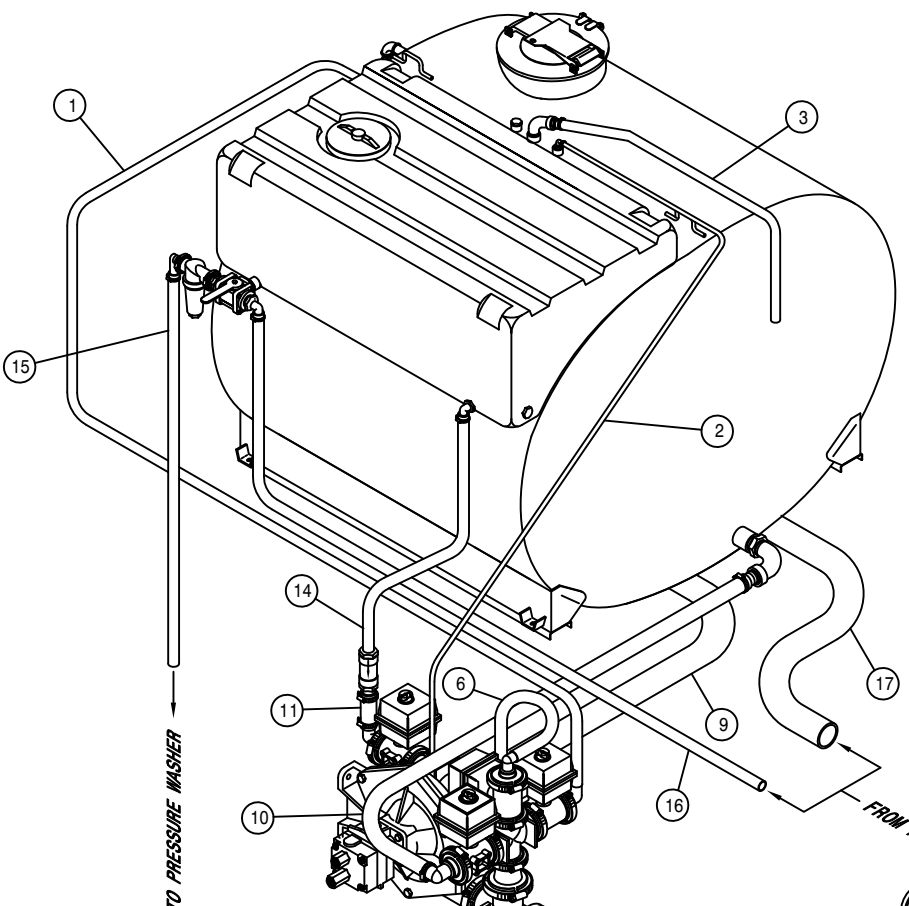

FRONT FILL SOLUTION HOISING SS (STANDARD)

DET.	QTY	PART NO.	DESCRIPTION
1	1	601273	HOSE, 1 X 132 1BR BLK EPDM
2	1	601490	HOSE, 1/4 X 95 1 BR BLK EPDM
3	1	601496	HOSE, 1 X 120 1BR BLK EPDM
4	1	601501	HOSE, 2 X 27 2F-1W EPDM
5	1	601502	HOSE, 2 X 56 2F-1W EPDM
6	1	601531	HOSE, 1 X 15 1BR BLK EPDM
7	1	601514	HOSE, 1/2 X 66 1BR BLK EPDM
8	1	601562	HOSE, 1/2 X 140 1BR BLK EPDM
9	2	601573	HOSE, 2 X 48 2F-1W EPDM
10	1	601591	HOSE, 1 1/2 X 53 2BR BLK EPDM
11	1	601590	HOSE, 1 X 6 1BR BLK EPDM
12	2	601525	HOSE, 1 X 84 1BR BLK EPDM
13	2	601566	HOSE, 1/2 X 252 1BR BLK EPDM
14	1	601491	HOSE, 1 X 30 1BR BLK EPDM
15	1	601179	HOSE, 1 X 26 1BR BLK EPDM
16	1	601497	HOSE, 1 X 200 1BR BLK EPDM
17	1	601575	HOSE, 3 X 160 POLY HELIX EPDM
18	1	601521	HOSE, 1 X 72 1BR BLK EPDM
19	1	601522	HOSE, 1 X 204 1BR BLK EPDM
20	2	601523	HOSE, 1 X 300 1BR BLK EPDM
21	1	601524	HOSE, 1 X 396 1BR BLK EPDM

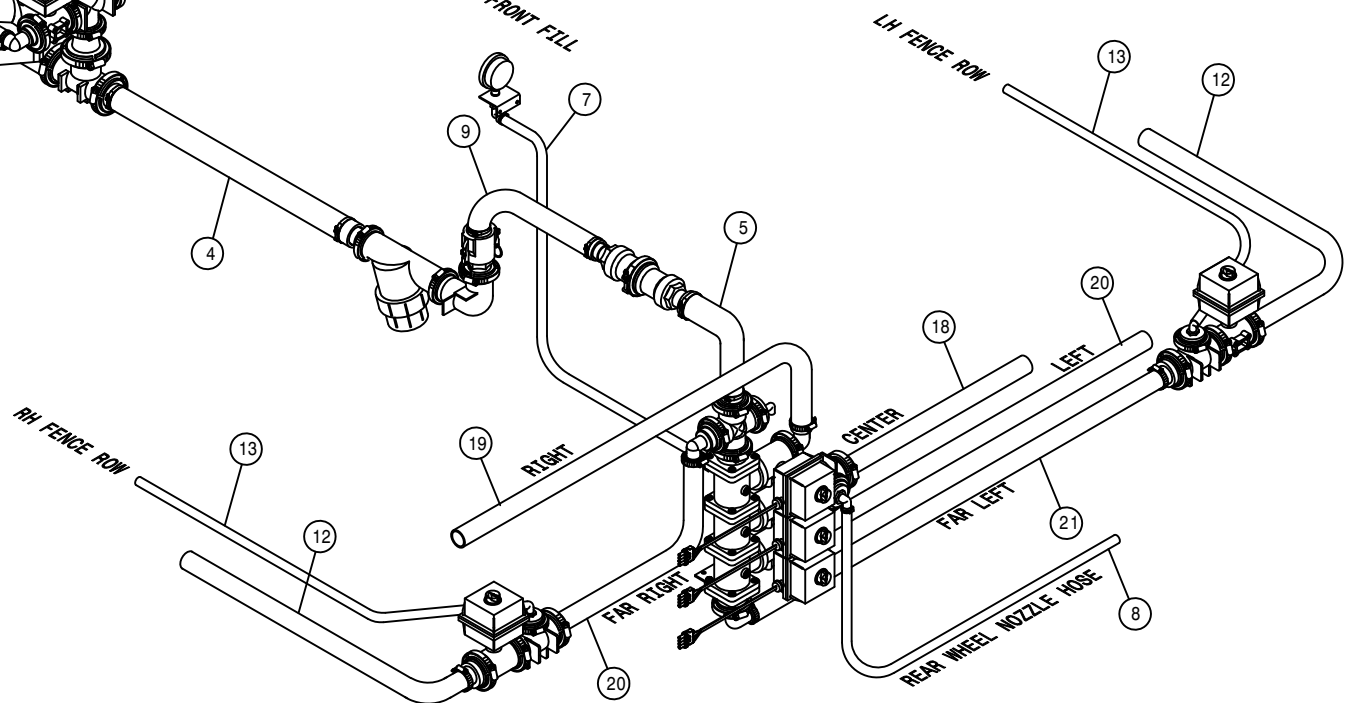

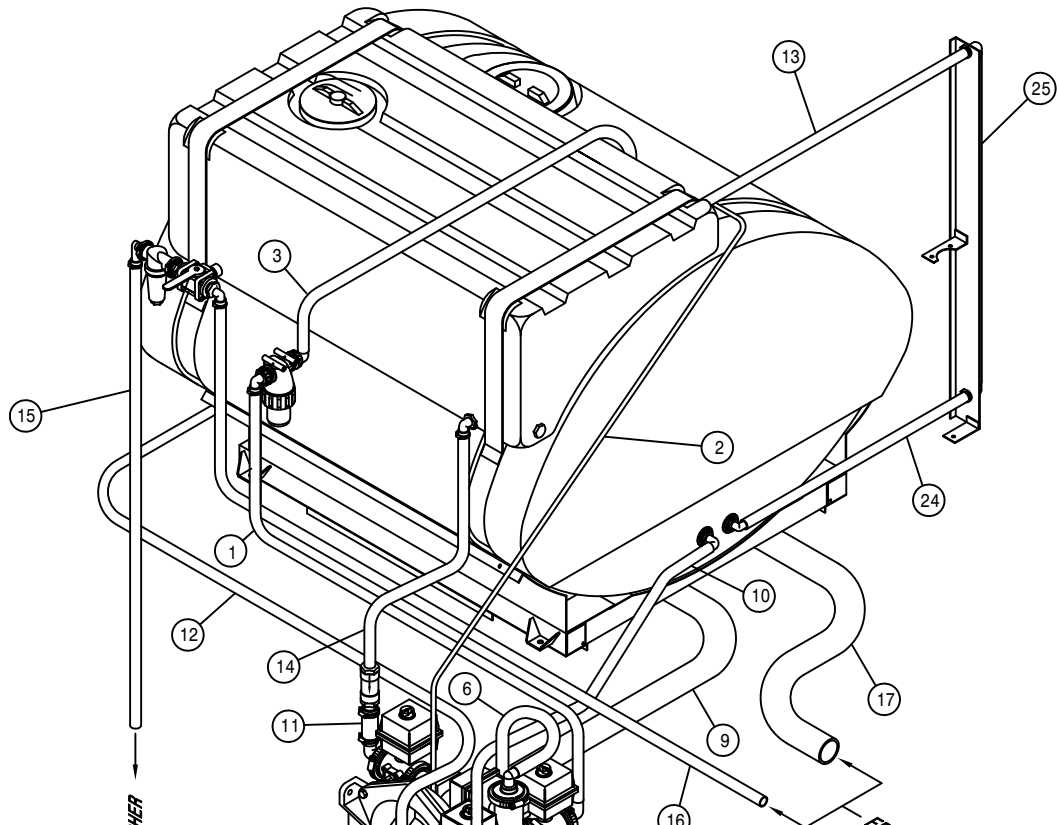

FRONT FILL SOLUTION HOISING POLY (STANDARD)

DET.	QTY	PART NO.	DESCRIPTION
1	1	601588	HOSE, 1 X 28 1BR BLK EPDM
2	1	601490	HOSE, 1/4 X 95 1 BR BLK EPDM
3	1	601589	HOSE, 1 X 80 1BR BLK EPDM
4	1	601501	HOSE, 2 X 27 2F-1W EPDM
5	1	601502	HOSE, 2 X 56 2F-1W EPDM
6	1	601531	HOSE, 1 X 15 1BR BLK EPDM
7	1	601514	HOSE, 1/2 X 66 1BR BLK EPDM
8	1	601562	HOSE, 1/2 X 140 1BR BLK EPDM
9	2	601573	HOSE, 2 X 48 2F-1W EPDM
10	1	601577	HOSE, 1 X 53 1BR BLK EPDM
11	1	601590	HOSE, 1 X 6 1BR BLK EPDM
12	1	601578	HOSE, 1 X 125 1BR BLK EPDM
13	1	601559	HOSE, 1" X 36 CLEAR VINYL
14	1	601491	HOSE, 1 X 30 1BR BLK EPDM
15	1	601179	HOSE, 1 X 26 1BR BLK EPDM
16	1	601497	HOSE, 1 X 200 1BR BLK EPDM
17	1	601575	HOSE, 3 X 160 POLY HELIX EPDM
18	1	601521	HOSE, 1 X 72 1BR BLK EPDM
19	1	601522	HOSE, 1 X 204 1BR BLK EPDM
20	2	601523	HOSE, 1 X 300 1BR BLK EPDM
21	1	601524	HOSE, 1 X 396 1BR BLK EPDM
22	2	601525	HOSE, 1 X 84 1BR BLK EPDM
23	2	601566	HOSE, 1/2 X 252 1BR BLK EPDM
24	1	601579	HOSE, 1" X 28 CLEAR VINYL
25	1	601580	HOSE, 1" X 47 CLEAR VINYL

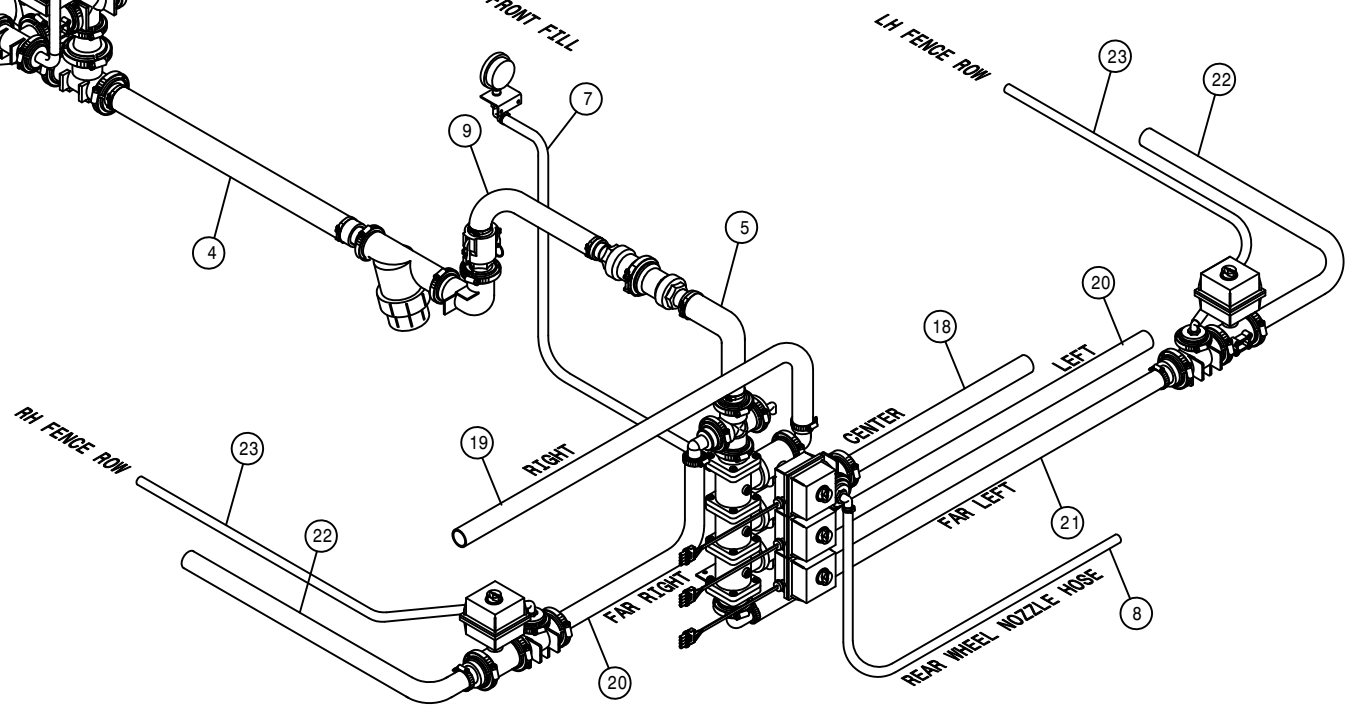

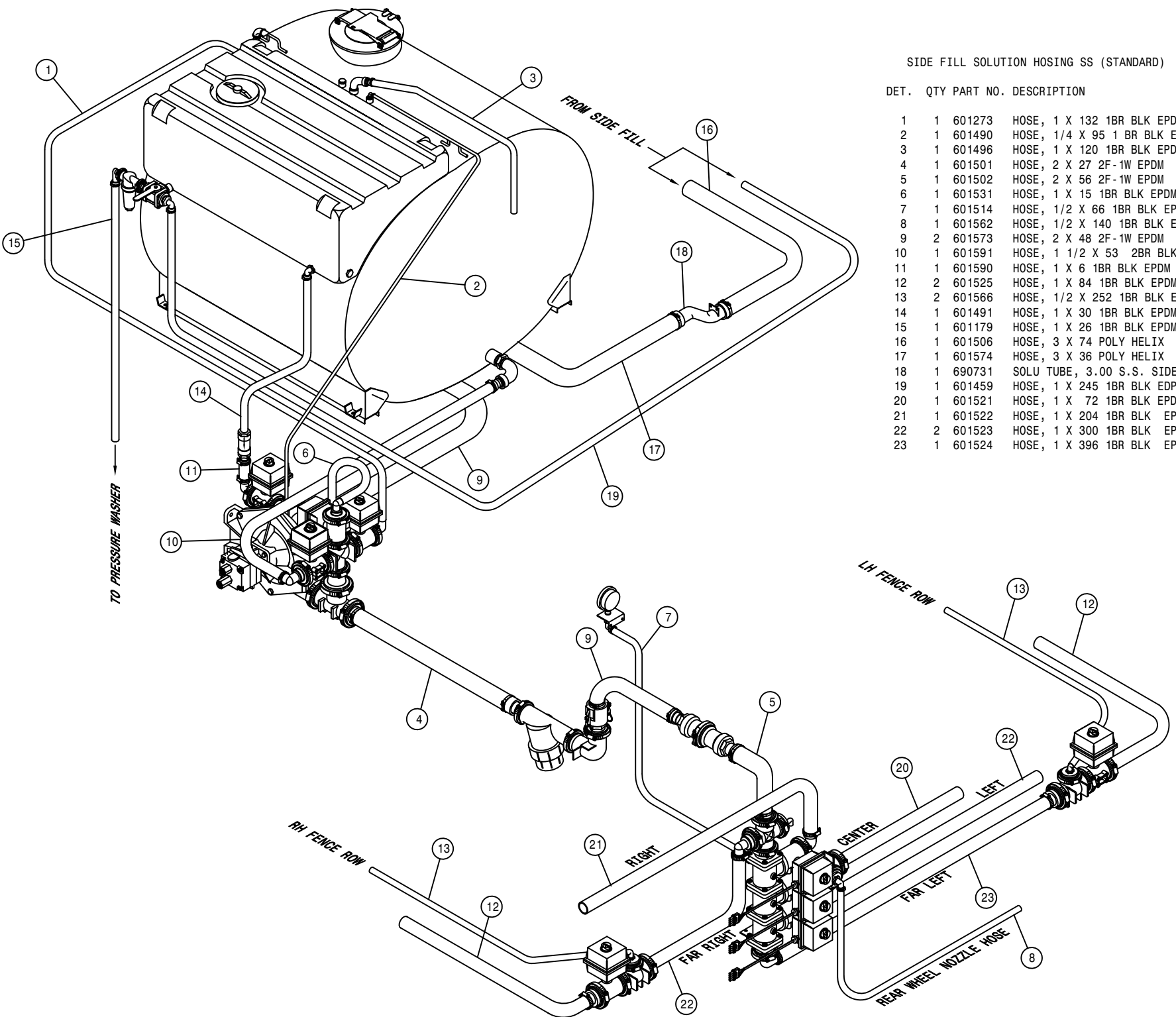

SIDE FILL SOLUTION HOISING SS (STANDARD)

DET.	QTY	PART NO.	DESCRIPTION
1	1	601273	HOSE, 1 X 132 1BR BLK EPDM
2	1	601490	HOSE, 1/4 X 95 1 BR BLK EPDM
3	1	601496	HOSE, 1 X 120 1BR BLK EPDM
4	1	601501	HOSE, 2 X 27 2F-1W EPDM
5	1	601502	HOSE, 2 X 56 2F-1W EPDM
6	1	601531	HOSE, 1 X 15 1BR BLK EPDM
7	1	601514	HOSE, 1/2 X 66 1BR BLK EPDM
8	1	601562	HOSE, 1/2 X 140 1BR BLK EPDM
9	2	601573	HOSE, 2 X 48 2F-1W EPDM
10	1	601591	HOSE, 1 1/2 X 53 2BR BLK EPDM
11	1	601590	HOSE, 1 X 6 1BR BLK EPDM
12	2	601525	HOSE, 1 X 84 1BR BLK EPDM
13	2	601566	HOSE, 1/2 X 252 1BR BLK EPDM
14	1	601491	HOSE, 1 X 30 1BR BLK EPDM
15	1	601179	HOSE, 1 X 26 1BR BLK EPDM
16	1	601506	HOSE, 3 X 74 POLY HELIX EPDM
17	1	601574	HOSE, 3 X 36 POLY HELIX EPDM
18	1	690731	SOLU TUBE, 3.00 S.S. SIDE FILL
19	1	601459	HOSE, 1 X 245 1BR BLK EDPM
20	1	601521	HOSE, 1 X 72 1BR BLK EPDM
21	1	601522	HOSE, 1 X 204 1BR BLK EPDM
22	2	601523	HOSE, 1 X 300 1BR BLK EPDM
23	1	601524	HOSE, 1 X 396 1BR BLK EPDM

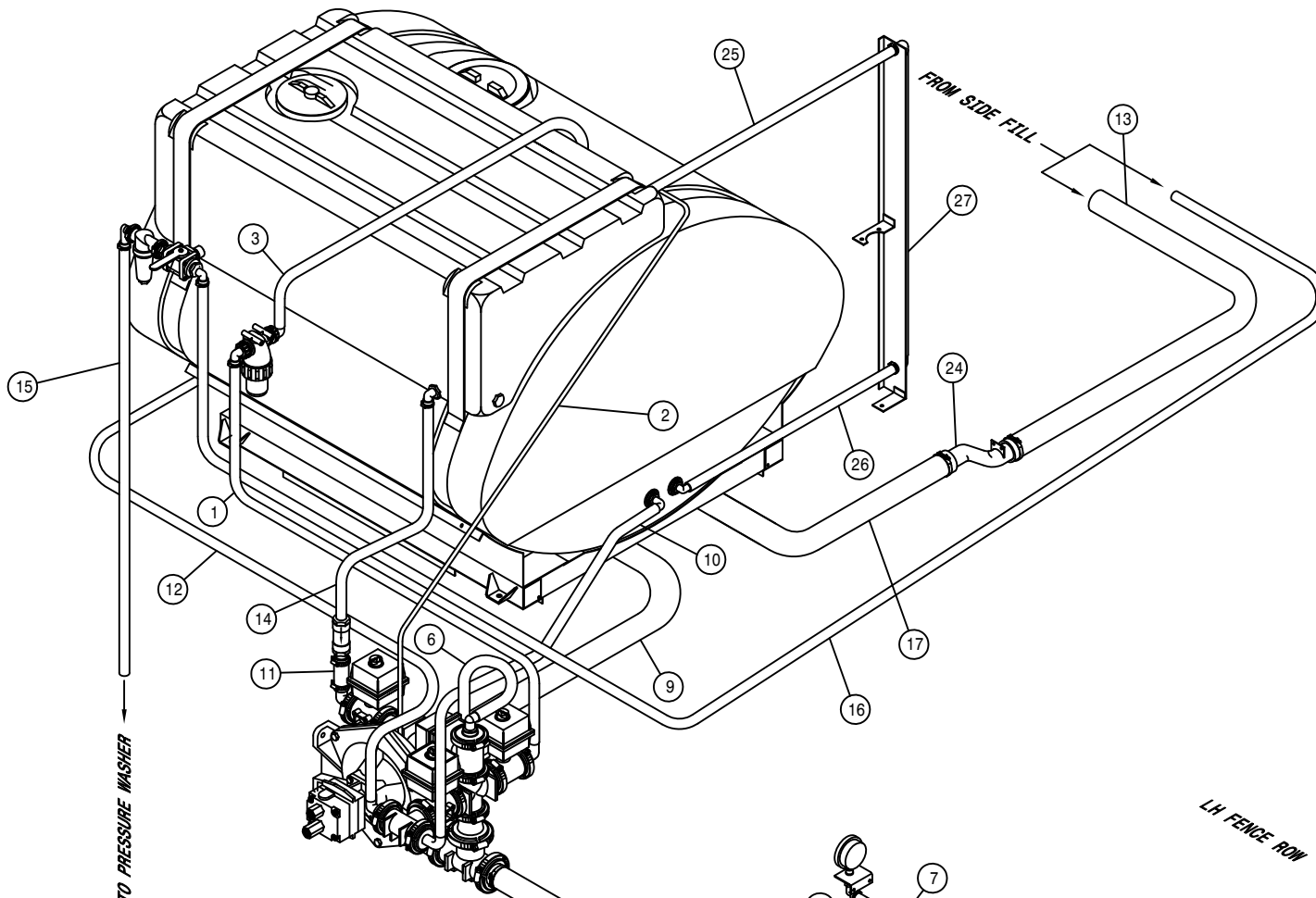

SIDE FILL SOLUTION HOISING POLY (STANDARD)

DET.	QTY	PART NO.	DESCRIPTION
1	1	601588	HOSE, 1 X 28 1BR BLK EPDM
2	1	601490	HOSE, 1/4 X 95 1 BR BLK EPDM
3	1	601589	HOSE, 1 X 80 1BR BLK EPDM
4	1	601501	HOSE, 2 X 27 2F-1W EPDM
5	1	601502	HOSE, 2 X 56 2F-1W EPDM
6	1	601531	HOSE, 1 X 15 1BR BLK EPDM
7	1	601514	HOSE, 1/2 X 66 1BR BLK EPDM
8	1	601562	HOSE, 1/2 X 140 1BR BLK EPDM
9	2	601573	HOSE, 2 X 48 2F-1W EPDM
10	1	601577	HOSE, 1 X 53 1BR BLK EPDM
11	1	601590	HOSE, 1 X 6 1BR BLK EPDM
12	1	601578	HOSE, 1 X 125 1BR BLK EPDM
13	1	601506	HOSE, 3 X 74 POLY HELIX EPDM
14	1	601491	HOSE, 1 X 30 1BR BLK EPDM
15	1	601179	HOSE, 1 X 26 1BR BLK EPDM
16	1	601459	HOSE, 1 X 245 1BR BLK EPDM
17	1	601574	HOSE, 3 X 36 POLY HELIX EPDM
18	1	601521	HOSE, 1 X 72 1BR BLK EPDM
19	1	601522	HOSE, 1 X 204 1BR BLK EPDM
20	2	601523	HOSE, 1 X 300 1BR BLK EPDM
21	1	601524	HOSE, 1 X 396 1BR BLK EPDM
22	2	601525	HOSE, 1 X 84 1BR BLK EPDM
23	2	601566	HOSE, 1/2 X 252 1BR BLK EPDM
24	1	690731	SOLU TUBE, 3.00 S.S. SIDE FILL
25	1	601559	HOSE, 1" X 36 CLEAR VINYL
26	1	601579	HOSE, 1" X 28 CLEAR VINYL
27	1	601580	HOSE, 1" X 47 CLEAR VINYL

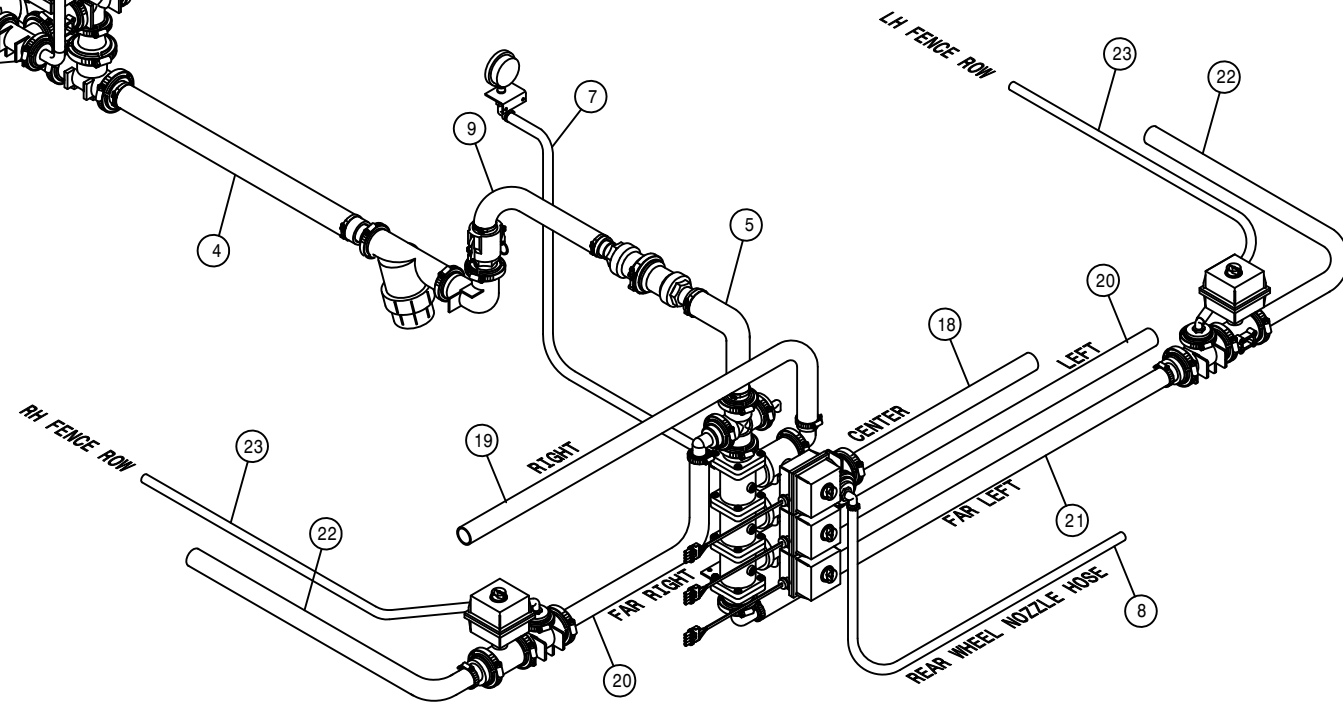

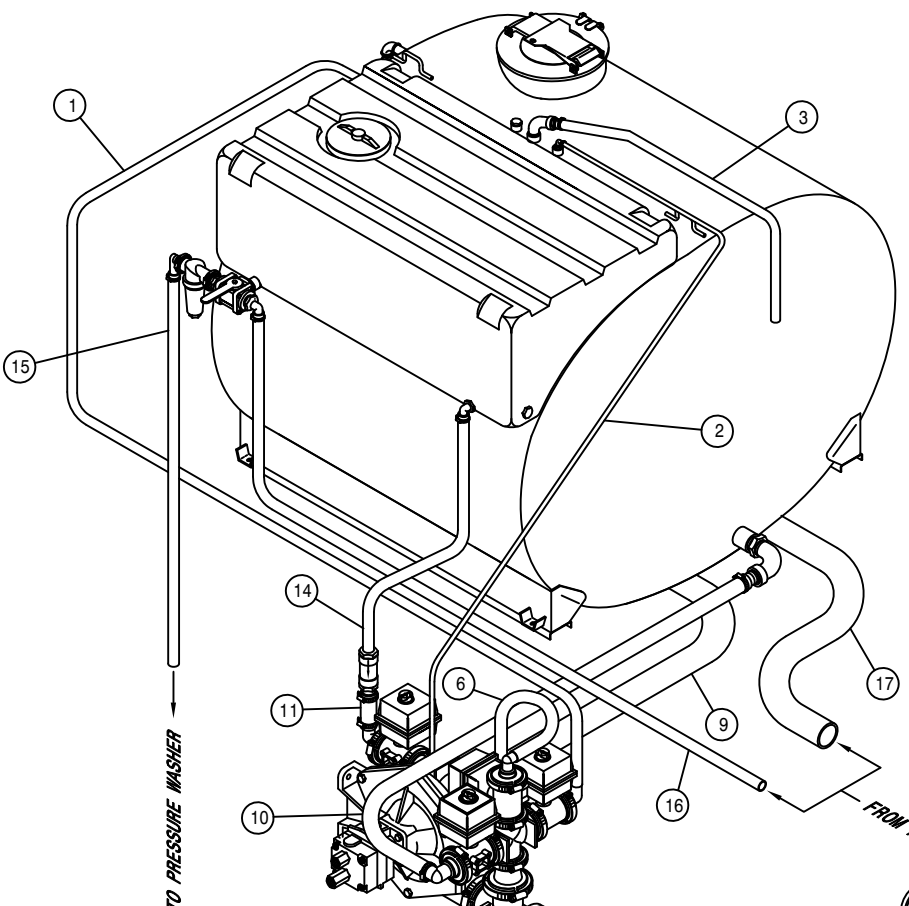

FRONT FILL SOLUTION HOSEING SS (HI-VOLUME)

DET.	QTY	PART NO.	DESCRIPTION
1	1	601273	HOSE, 1 X 132 1BR BLK EPDM
2	1	601490	HOSE, 1/4 X 95 1 BR BLK EPDM
3	1	601496	HOSE, 1 X 120 1BR BLK EPDM
4	1	601501	HOSE, 2 X 27 2F-1W EPDM
5	1	601502	HOSE, 2 X 56 2F-1W EPDM
6	1	601531	HOSE, 1 X 15 1BR BLK EPDM
7	1	601514	HOSE, 1/2 X 66 1BR BLK EPDM
8	1	601562	HOSE, 1/2 X 140 1BR BLK EPDM
9	2	601573	HOSE, 2 X 48 2F-1W EPDM
10	1	601591	HOSE, 1 1/2 X 53 2BR BLK EPDM
11	1	601590	HOSE, 1 X 6 1BR BLK EPDM
12	2	601240	HOSE, 1 1/2 X 84 2F-1W EPDM
13	2	601566	HOSE, 1/2 X 252 1BR BLK EPDM
14	1	601491	HOSE, 1 X 30 1BR BLK EPDM
15	1	601179	HOSE, 1 X 26 1BR BLK EPDM
16	1	601497	HOSE, 1 X 200 1BR BLK EPDM
17	1	601575	HOSE, 3 X 160 POLY HELIX EPDM
18	1	601516	HOSE, 1 1/2 X 72 2BR BLK EPDM
19	1	601517	HOSE, 1 1/2 X 204 2BR BLK EPDM
20	2	601518	HOSE, 1 1/2 X 300 2BR BLK EPDM
21	1	601519	HOSE, 1 1/2 X 396 2BR BLK EPDM

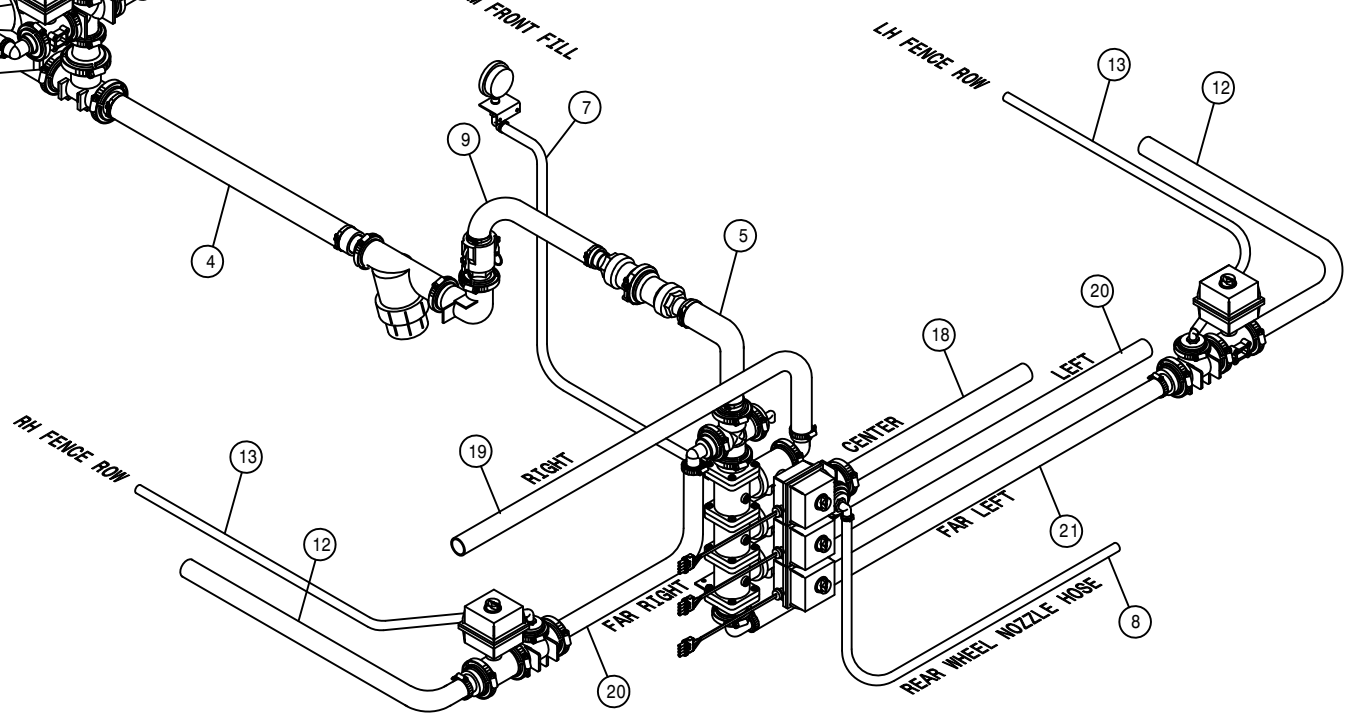

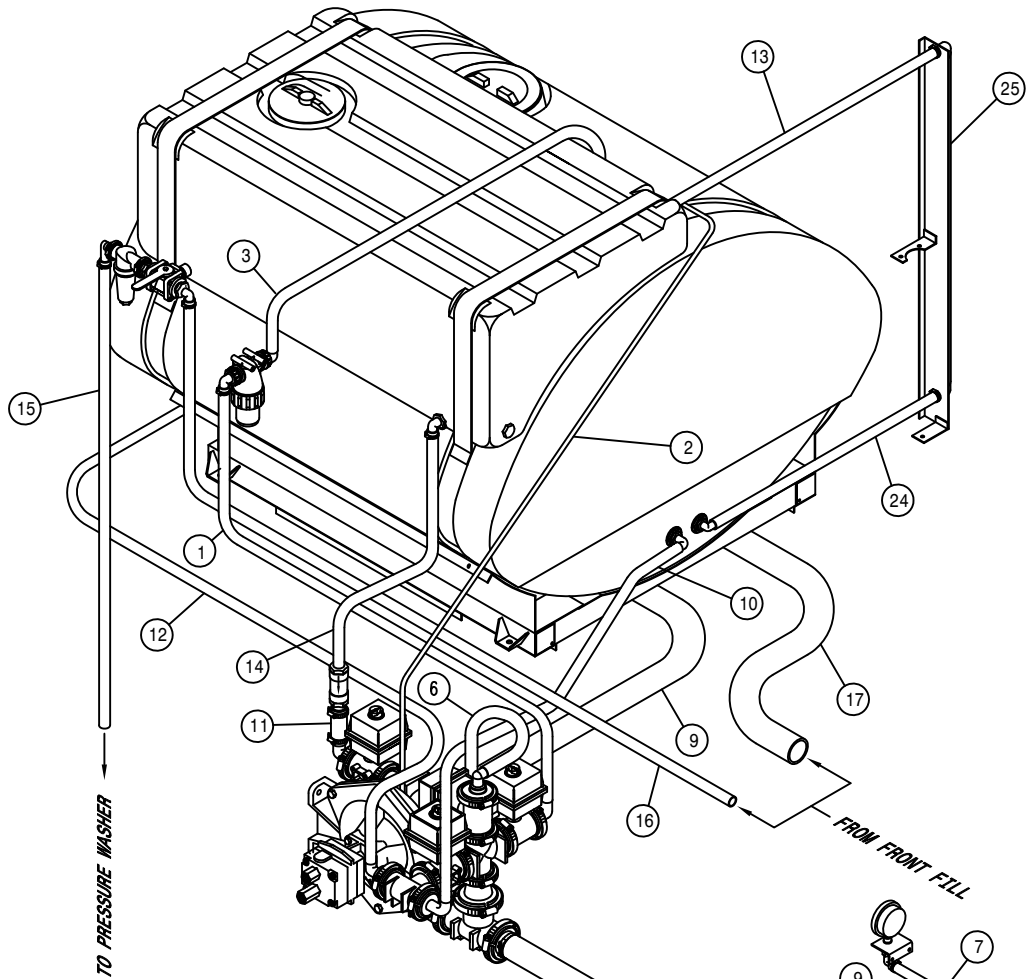

FRONT FILL SOLUTION HOSEING POLY (HI-VOLUME)

DET. QTY PART NO. DESCRIPTION

DET.	QTY	PART NO.	DESCRIPTION
1	1	601588	HOSE, 1 X 28 1BR BLK EPDM
2	1	601490	HOSE, 1/4 X 95 1 BR BLK EPDM
3	1	601589	HOSE, 1 X 80 1BR BLK EPDM
4	1	601501	HOSE, 2 X 27 2F-1W EPDM
5	1	601502	HOSE, 2 X 56 2F-1W EPDM
6	1	601531	HOSE, 1 X 15 1BR BLK EPDM
7	1	601514	HOSE, 1/2 X 66 1BR BLK EPDM
8	1	601562	HOSE, 1/2 X 140 1BR BLK EPDM
9	2	601573	HOSE, 2 X 48 2F-1W EPDM
10	1	601577	HOSE, 1 X 53 1BR BLK EPDM
11	1	601590	HOSE, 1 X 6 1BR BLK EPDM
12	1	601578	HOSE, 1 X 125 1BR BLK EPDM
13	1	601559	HOSE, 1" X 36 CLEAR VINYL
14	1	601491	HOSE, 1 X 30 1BR BLK EPDM
15	1	601179	HOSE, 1 X 26 1BR BLK EPDM
16	1	601497	HOSE, 1 X 200 1BR BLK EPDM
17	1	601575	HOSE, 3 X 160 POLY HELIX EPDM
18	1	601516	HOSE, 1 1/2 X 72 2BR BLK EPDM
19	1	601517	HOSE, 1 1/2 X 204 2BR BLK EPDM
20	2	601518	HOSE, 1 1/2 X 300 2BR BLK EPDM
21	1	601519	HOSE, 1 1/2 X 396 2BR BLK EPDM
22	2	601240	HOSE, 1 1/2 X 84 2F-1W EPDM
23	2	601566	HOSE, 1/2 X 252 1BR BLK EPDM
24	1	601579	HOSE, 1" X 28 CLEAR VINYL
25	1	601580	HOSE, 1" X 47 CLEAR VINYL

TO PRESSURE WASHER

FROM FRONT FILL

RH FENCE ROW

RIGHT

FAR RIGHT

CENTER

FAR LEFT

LH FENCE ROW

REAR WHEEL NOZZLE HOSE

SIDE FILL SOLUTION HOISING SS (HI-VOLUME)

DET. QTY PART NO. DESCRIPTION

DET.	QTY	PART NO.	DESCRIPTION
1	1	601273	HOSE, 1 X 132 1BR BLK EPDM
2	1	601490	HOSE, 1/4 X 95 1 BR BLK EPDM
3	1	601496	HOSE, 1 X 120 1BR BLK EPDM
4	1	601501	HOSE, 2 X 27 2F-1W EPDM
5	1	601502	HOSE, 2 X 56 2F-1W EPDM
6	1	601531	HOSE, 1 X 15 1BR BLK EPDM
7	1	601514	HOSE, 1/2 X 66 1BR BLK EPDM
8	1	601562	HOSE, 1/2 X 140 1BR BLK EPDM
9	2	601573	HOSE, 2 X 48 2F-1W EPDM
10	1	601591	HOSE, 1 1/2 X 53 2BR BLK EPDM
11	1	601590	HOSE, 1 X 6 1BR BLK EPDM
12	1	601516	HOSE, 1 1/2 X 72 2BR BLK EPDM
13	1	601517	HOSE, 1 1/2 X 204 2BR BLK EPDM
14	1	601491	HOSE, 1 X 30 1BR BLK EPDM
15	1	601179	HOSE, 1 X 26 1BR BLK EPDM
16	1	601506	HOSE, 3 X 74 POLY HELIX EPDM
17	1	601574	HOSE, 3 X 36 POLY HELIX EPDM </td
18	1	690731	SOLU TUBE, 3.00 S.S. SIDE FILL
19	1	601459	HOSE, 1 X 245 1BR BLK EPDM
20	1	601518	HOSE, 1 1/2 X 300 2BR BLK EPDM
21	1	601519	HOSE, 1 1/2 X 396 2BR BLK EPDM
22	2	601240	HOSE, 1 1/2 X 84 2F-1W EPDM
23	2	601566	HOSE, 1/2 X 252 1BR BLK EPDM

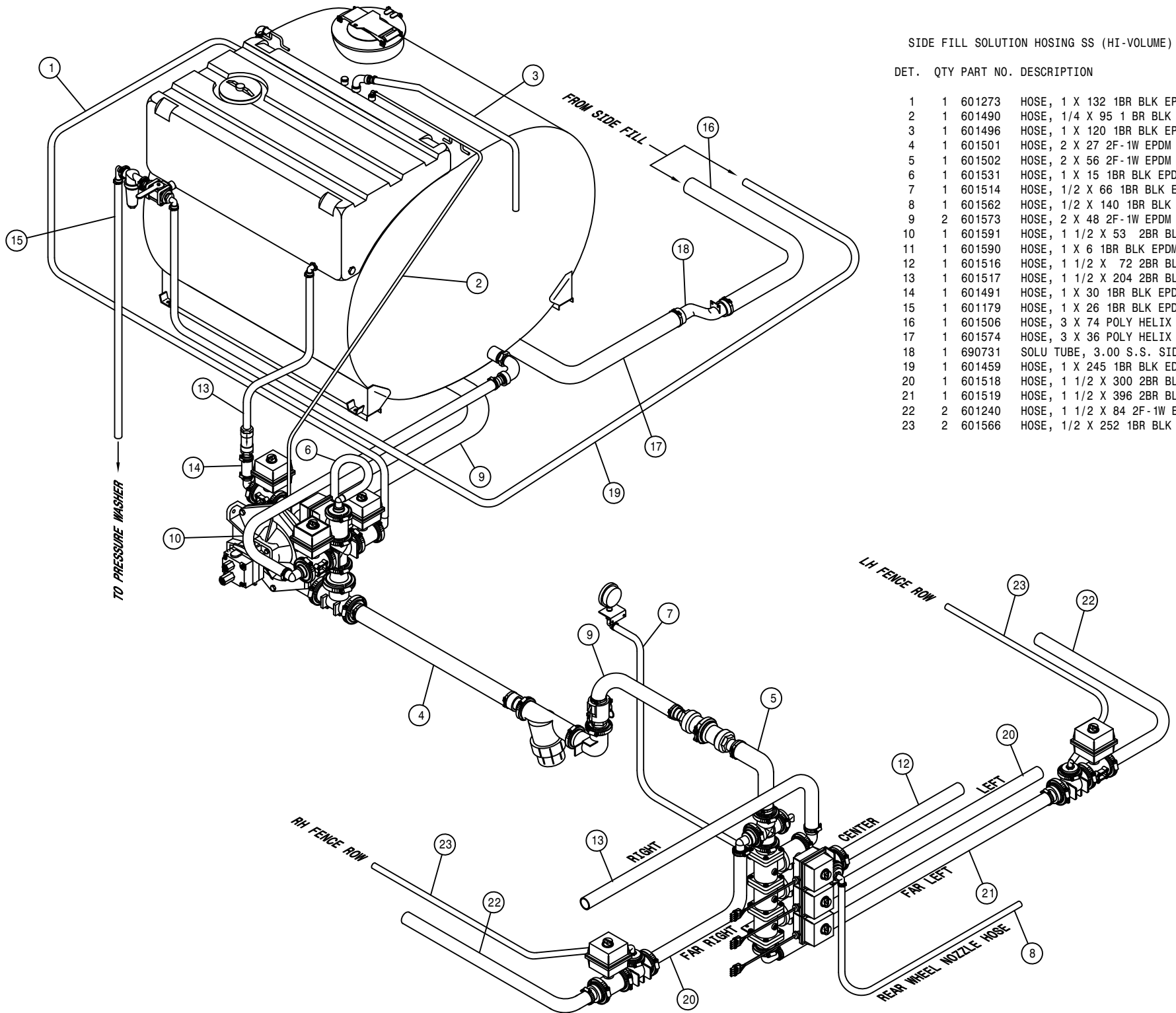

SIDE FILL SOLUTION HOISING POLY (HI-VOLUME)

DET. QTY PART NO. DESCRIPTION

DET.	QTY	PART NO.	DESCRIPTION
1	1	601588	HOSE, 1 X 28 1BR BLK EPDM
2	1	601490	HOSE, 1/4 X 95 1 BR BLK EPDM
3	1	601589	HOSE, 1 X 80 1BR BLK EPDM
4	1	601501	HOSE, 2 X 27 2F-1W EPDM
5	1	601502	HOSE, 2 X 56 2F-1W EPDM
6	1	601531	HOSE, 1 X 15 1BR BLK EPDM
7	1	601514	HOSE, 1/2 X 66 1BR BLK EPDM
8	1	601562	HOSE, 1/2 X 140 1BR BLK EPDM
9	2	601573	HOSE, 2 X 48 2F-1W EPDM
10	1	601577	HOSE, 1 X 53 1BR BLK EPDM
11	1	601590	HOSE, 1 X 6 1BR BLK EPDM
12	1	601578	HOSE, 1 X 125 1BR BLK EPDM
13	1	601506	HOSE, 3 X 74 POLY HELIX EPDM
14	1	601491	HOSE, 1 X 30 1BR BLK EPDM
15	1	601179	HOSE, 1 X 26 1BR BLK EPDM
16	1	601459	HOSE, 1 X 245 1BR BLK EPDM
17	1	601574	HOSE, 3 X 36 POLY HELIX EPDM
18	1	601516	HOSE, 1 1/2 X 72 2BR BLK EPDM
19	1	601517	HOSE, 1 1/2 X 204 2BR BLK EPDM
20	2	601518	HOSE, 1 1/2 X 300 2BR BLK EPDM
21	1	601519	HOSE, 1 1/2 X 396 2BR BLK EPDM
22	2	601240	HOSE, 1 1/2 X 84 2F-1W EPDM
23	2	601566	HOSE, 1/2 X 252 1BR BLK EPDM
24	1	690731	SOLU TUBE, 3.00 S.S. SIDE FILL
25	1	601559	HOSE, 1" X 36 CLEAR VINYL
26	1	601579	HOSE, 1" X 28 CLEAR VINYL
27	1	601580	HOSE, 1" X 47 CLEAR VINYL

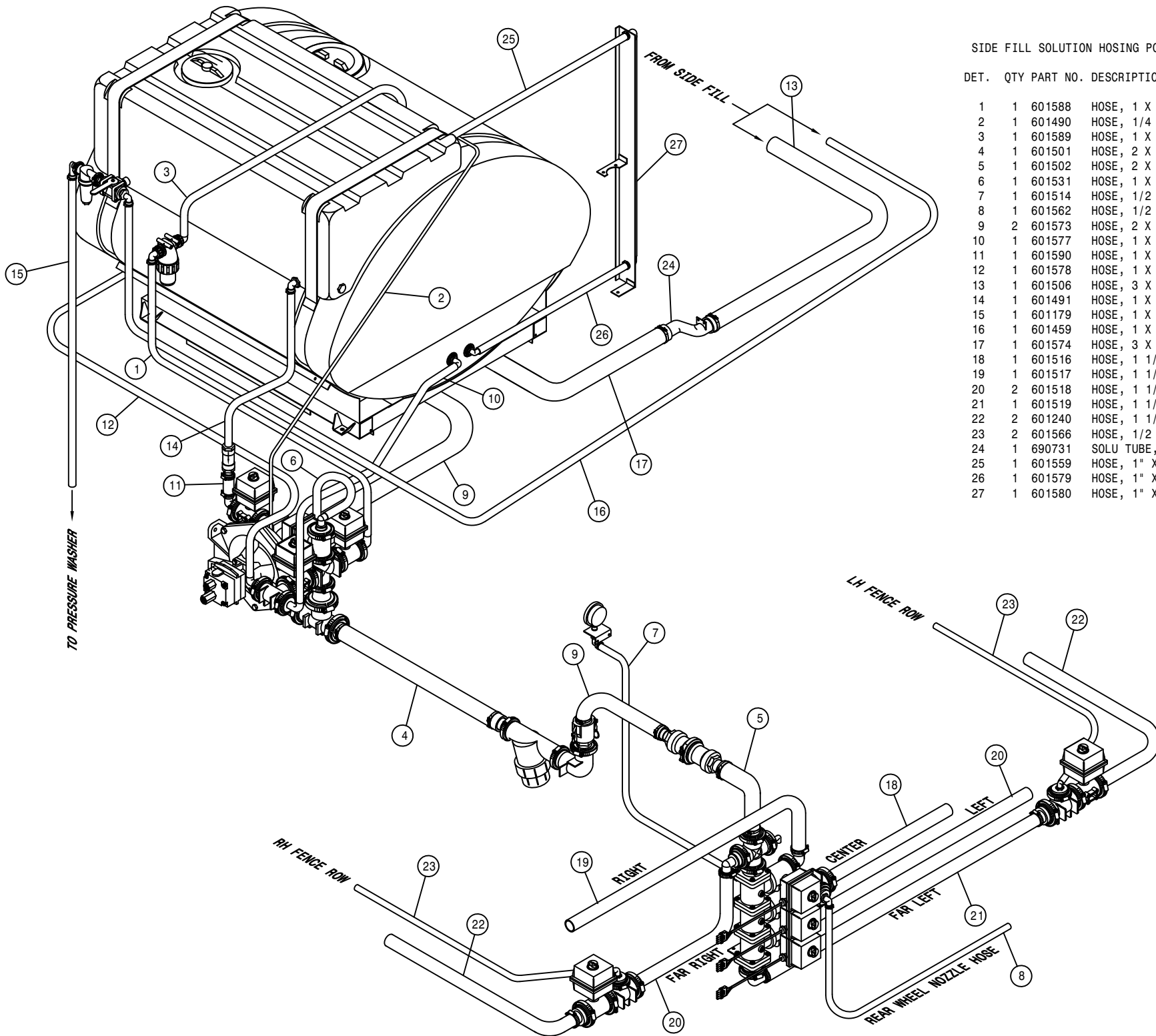

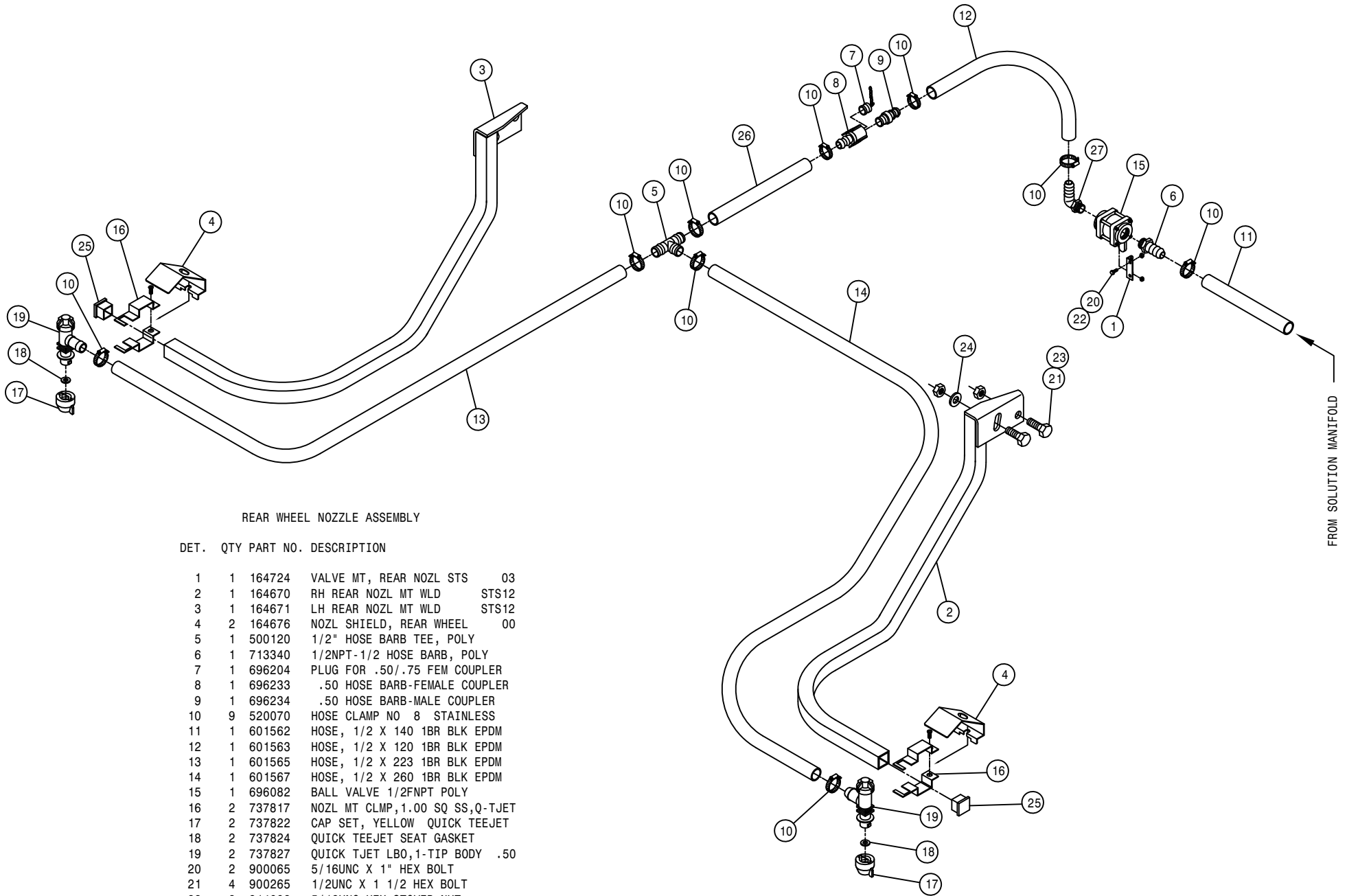

REAR WHEEL NOZZLE ASSEMBLY

DET. QTY PART NO. DESCRIPTION

1	1	164724	VALVE MT, REAR NOZL STS	03
2	1	164670	RH REAR NOZL MT WLD	STS12
3	1	164671	LH REAR NOZL MT WLD	STS12
4	2	164676	NOZL SHIELD, REAR WHEEL	00
5	1	500120	1/2" HOSE BARB TEE, POLY	
6	1	713340	1/2NPT-1/2 HOSE BARB, POLY	
7	1	696204	PLUG FOR .50/.75 FEM COUPLER	
8	1	696233	.50 HOSE BARB-FEMALE COUPLER	
9	1	696234	.50 HOSE BARB-MALE COUPLER	
10	9	520070	HOSE CLAMP NO 8 STAINLESS	
11	1	601562	HOSE, 1/2 X 140 1BR BLK EPDM	
12	1	601563	HOSE, 1/2 X 120 1BR BLK EPDM	
13	1	601565	HOSE, 1/2 X 223 1BR BLK EPDM	
14	1	601567	HOSE, 1/2 X 260 1BR BLK EPDM	
15	1	696082	BALL VALVE 1/2FNPT POLY	
16	2	737817	NOZL MT CLMP,1.00 SQ SS,Q-TJET	
17	2	737822	CAP SET, YELLOW QUICK TEEJET	
18	2	737824	QUICK TEEJET SEAT GASKET	
19	2	737827	QUICK TJET LBO,1-TIP BODY .50	
20	2	900065	5/16UNC X 1" HEX BOLT	
21	4	900265	1/2UNC X 1 1/2 HEX BOLT	
22	2	914002	5/16UNC HEX STOVER NUT	
23	4	914008	1/2UNC HEX STOVER NUT	
24	2	920004	1/2 SAE FLAT WASHER	
25	2	629727	FINISH PLUG FOR 1 IN X 16 GA	
26	1	601572	HOSE, 1/2 X 70 1BR BLK EPDM	
27	1	500047	1/2NPT-90-1/2 HOSE BARB, POLY	

FROM SOLUTION MANIFOLD

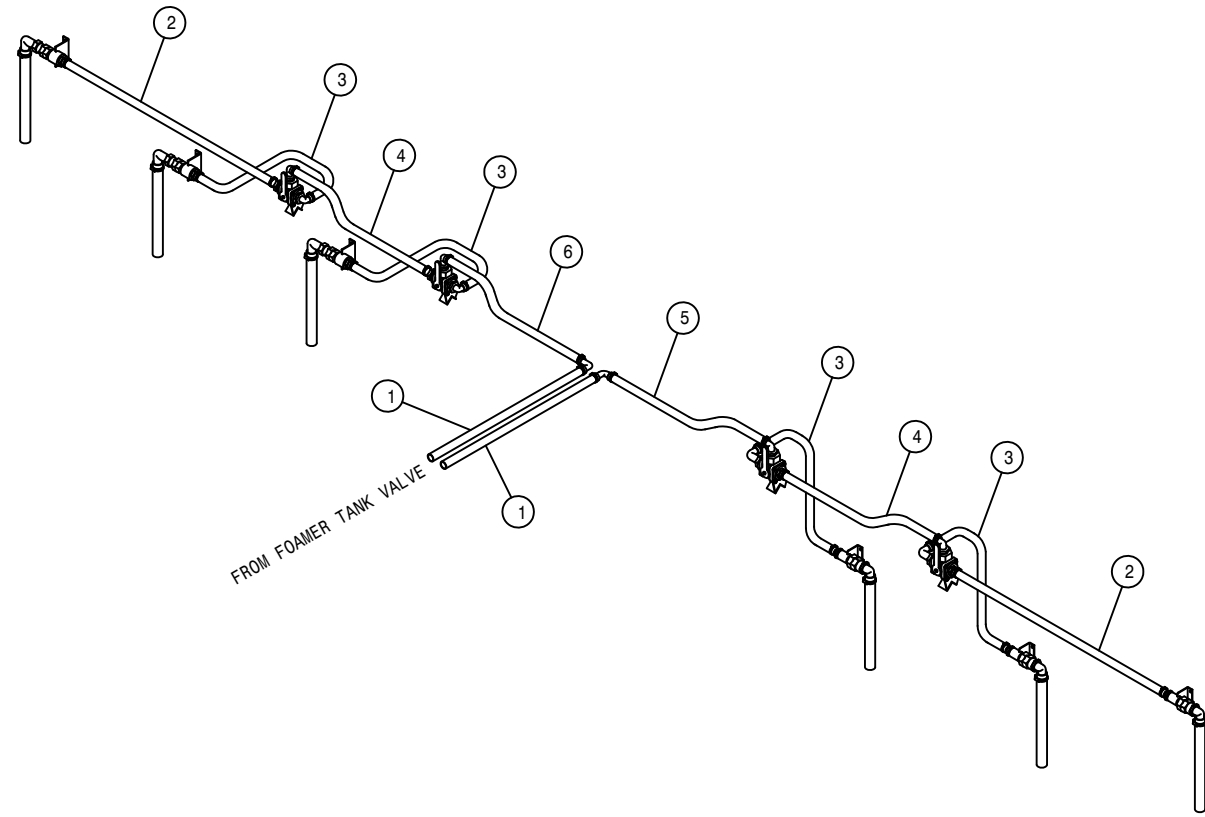

90' BOOM FOAMER HOSING

DET. QTY PART NO. DESCRIPTION

1	2	195908	HOSE, 3/4ID-1/8W CLEAR VINYL X 206"
2	2	195908	HOSE, 3/4ID-1/8W CLEAR VINYL X 77"
3	4	195908	HOSE, 3/4ID-1/8W CLEAR VINYL X 24"
4	2	195908	HOSE, 3/4ID-1/8W CLEAR VINYL X 128"
5	1	195908	HOSE, 3/4ID-1/8W CLEAR VINYL X 420"
6	1	195908	HOSE, 3/4ID-1/8W CLEAR VINYL X 584"

FOAMER TANK ASSEMBLY

DET. QTY PART NO. DESCRIPTION

1	2	195908	HOSE, 3/4ID-1/8W CLEAR VINYL
2	1	601482	HOSE, 3/8 X 80 AIR
3	2	696181	3/4" ELECT SOLU SOLE VALVE 02
4	6	470294	RUBBER BUMPER, RECESS, .63H-1.5D
5	2	696208	.75 HOSE BARB-MALE COUPLER
6	1	505205	BLK PIPE NIPPLE 1.00NPT-5.00
7	2	505211	3/8-1/4NPT REDU BUSH, BRS
8	3	520120	HOSE CLAMP NO 4 STAINLESS
9	6	520055	HOSE CLAMP NO 12 STAINLESS
10	1	601419	HOSE, 3/8 X 30 CLEAR VINYL
11	1	601420	HOSE, 3/8 X 48 CLEAR VINYL
12	2	618571	1/4MNPT-90-1/4MNPT LBO
13	1	695900	BALL VALVE 1IN FNPT POLY
14	2	696120	BALL VALVE, 1/4NPT, STEEL
15	1	696134	BALL VALVE 2IN FNPT POLY
16	2	500043	3/4NPT PIPE PLUG, POLY
17	1	701112	FOAM MARKER TANK, 36 GAL SS
18	2	701214	1/2NPT-90-3/4HBARB, 1/4TAP, POLY
19	2	701215	1/4PIPE PLUG, .187 ORIFICE, POLY
20	1	711050	3/4"FNPT CHECK VALVE S.S.
21	1	711043	1/4MNPT-3/8 NYL TUBE SNGL LBO
22	1	783304	1/4 NPT X 3/8 HOSE BARB, BRS
23	6	900064	5/16UNC X 3/4 HEX BOLT
24	6	914002	5/16UNC HEX STOVER NUT
25	7	914008	1/2UNC HEX STOVER NUT
26	3	900264	1/2UNC X 1 1/4 HEX BOLT
27	1	701158	FOAMER TANK MT WLD STS12 2000
28	2	701170	FOAMER TANK STRAP ASSY
29	1	701144	FOAMER AIR NOZZLE
30	1	500202	SS PIPE CPLG, 1/8NPT .563 OD
31	1	507021	SS PIPE NIPPLE, 1/8NPT X 6"
32	1	701143	FOAMER AIR TUBE FTG
33	2	507724	REDU BUSH 3/4MNPT X 1/4FNPT, SS
34	2	500079	3/4NPT-90 EL, POLY
35	2	696207	.75 HOSE BARB-FEMALE COUPLER
36	1	507728	REDU BUSH 1/2MNPT X 1/4FNPT, SS
37	1	500223	SS PIPE CPLG, 1/8NPT

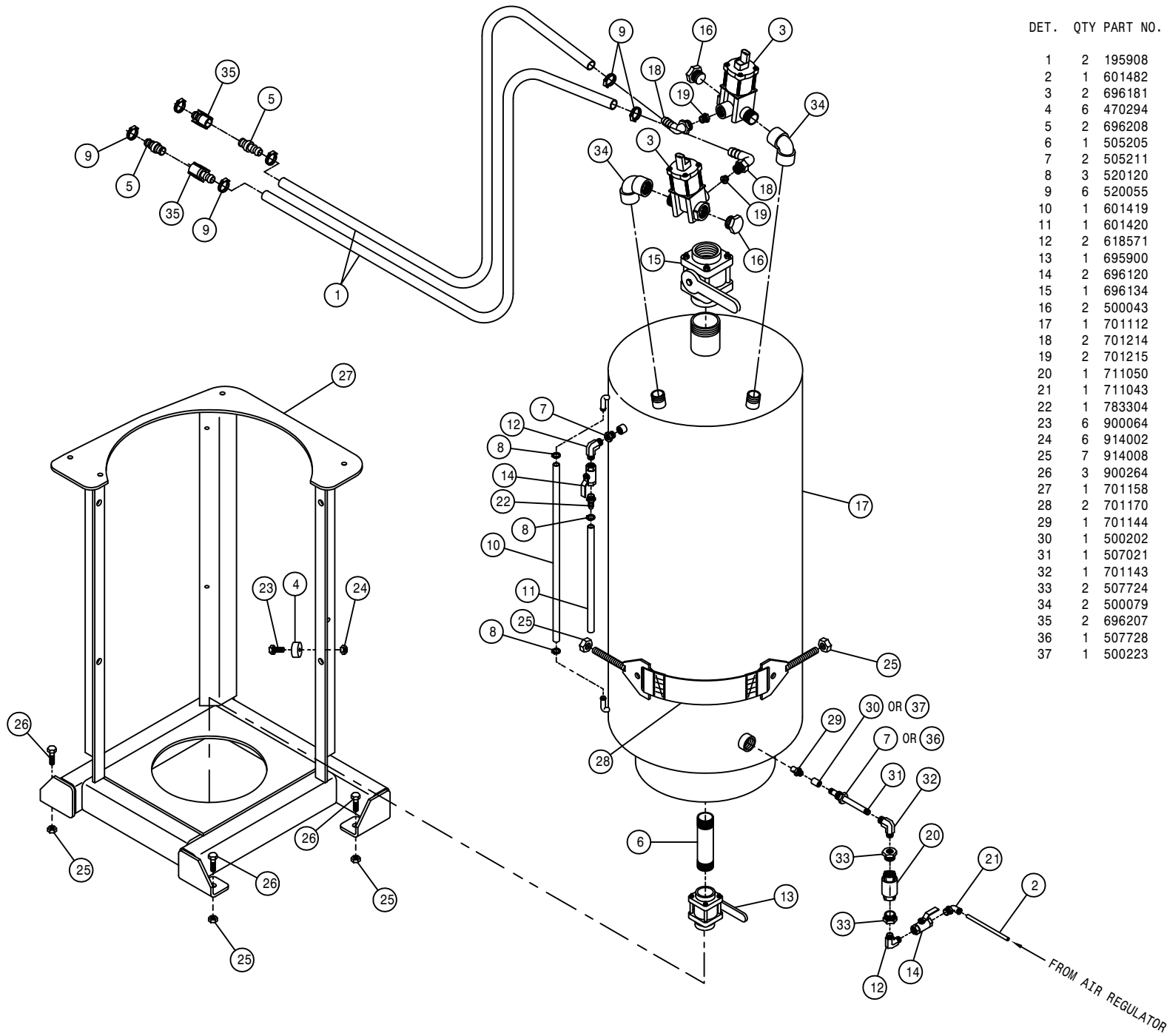

FRESH WATER TANK ASSEMBLY

DET. QTY PART NO. DESCRIPTION

DET.	QTY	PART NO.	DESCRIPTION
1	1	470318	RINSE TANK, 3 GAL SQ SAFETY
2	1	500019	3/4NPT-1/2HOSE BARB, POLY
3	1	500047	1/2NPT-90-1/2 HOSE BARB, POLY
4	2	520070	HOSE CLAMP NO 8 STAINLESS
5	1	601489	HOSE, 1/2 X 72 CLEAR VINYL
6	1	696082	BALL VALVE 1/2FNPT POLY
7	1	713340	1/2NPT-1/2 HOSE BARB, POLY
8	4	900064	5/16UNC X 3/4 HEX BOLT
9	5	900129	3/8UNC X 1" HEX BOLT
10	5	914004	3/8UNC HEX STOVER NUT
11	4	920501	5/16 LOCK WASHER
12	1	701174	FRESH WATER TANK MT WLD
13	1	701180	FRESH WATER TANK BRACE WLD
14	1	470337	6" LID FOR 3 GAL TANK 470318
15	1	314901	FILTER MINDER AIR RESTRICT GA
16	1	701310	AIR PRESS GAUGE, 1/8"BOT
17	1	711019	1/4"MNPT AIR REGULATOR
18	1	711021	1 1/4-18 NUT, AIR REGULATOR MT
19	2	711043	1/4MNPT-3/8 NYL TUBE SNGL LBO
20	1	601587	HOSE, 3/8 X 102 AIR
21	1	601482	HOSE, 3/8 X 80 AIR

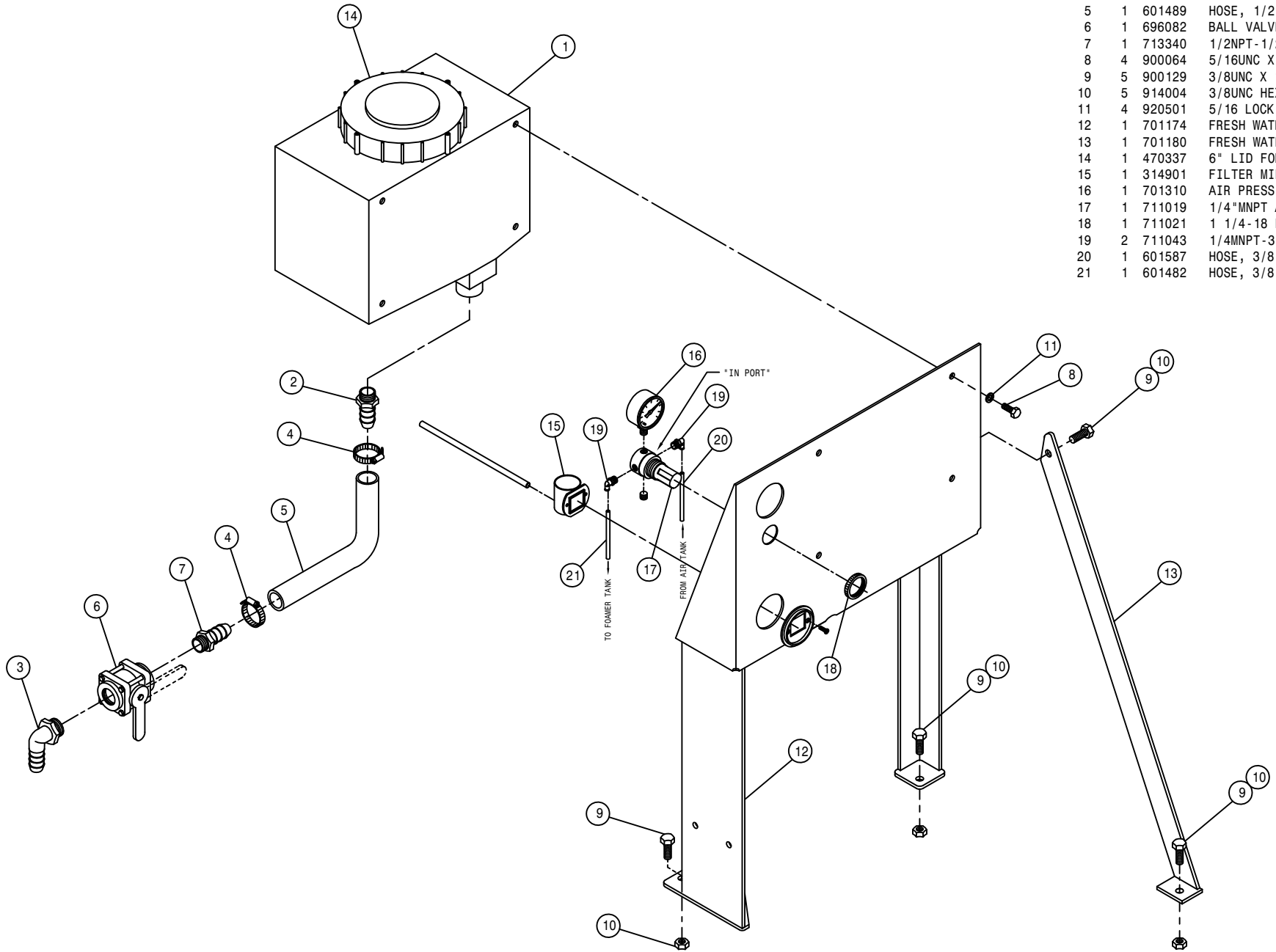

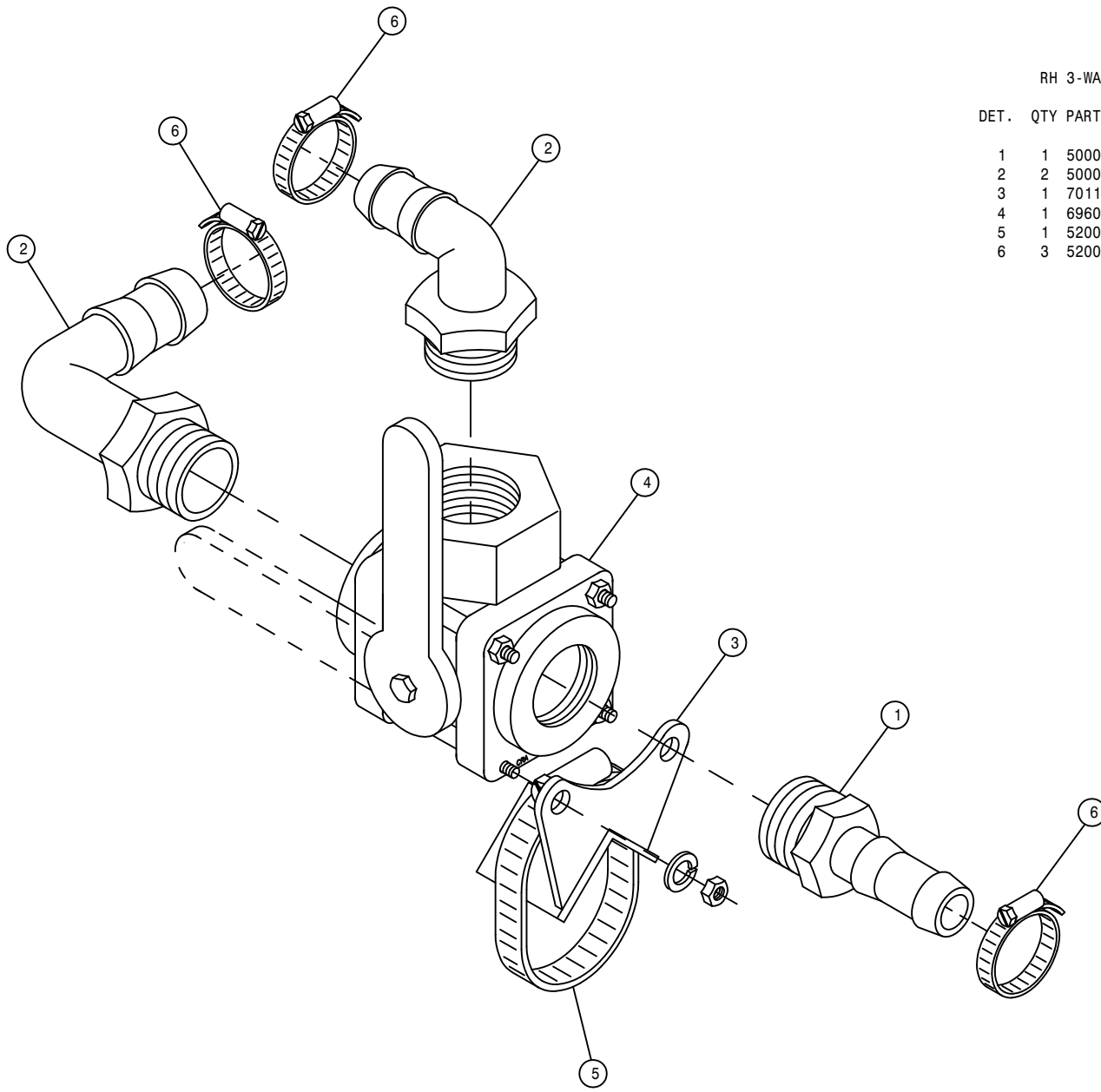

RH 3-WAY FOAMER VALVE ASSEMBLY

DET.	QTY	PART NO.	DESCRIPTION
	1	500022	3/4NPT-3/4HOSE BARB, POLY
	2	500054	3/4NPT-90-3/4 HOSE BARB, POLY
	3	701191	1" SOLU VLV MT WLD
	4	696003	BALL VLV,3/4NPT 3WAY-SIDE POLY
	5	520085	HOSE CLAMP NO 24 STAINLESS
	6	520055	HOSE CLAMP NO 12 STAINLESS

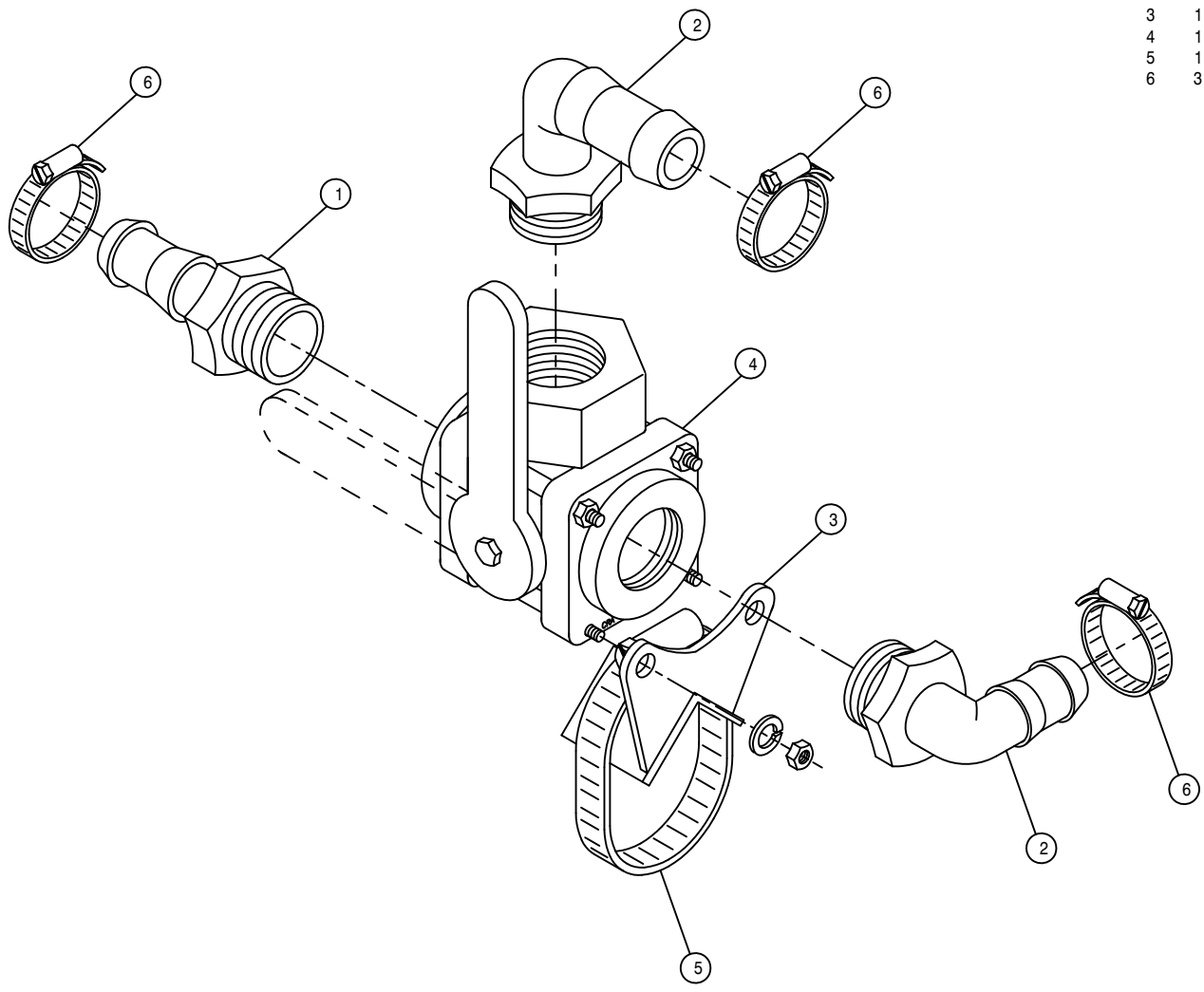

LH 3-WAY FOAMER VALVE ASSEMBLY

DET.	QTY	PART NO.	DESCRIPTION
	1	500022	3/4NPT-3/4HOSE BARB, POLY
	2	500054	3/4NPT-90-3/4 HOSE BARB, POLY
	3	701191	1" SOLU VLV MT WLD
	4	696003	BALL VLV,3/4NPT 3WAY-SIDE POLY
	5	520085	HOSE CLAMP NO 24 STAINLESS
	6	520055	HOSE CLAMP NO 12 STAINLESS

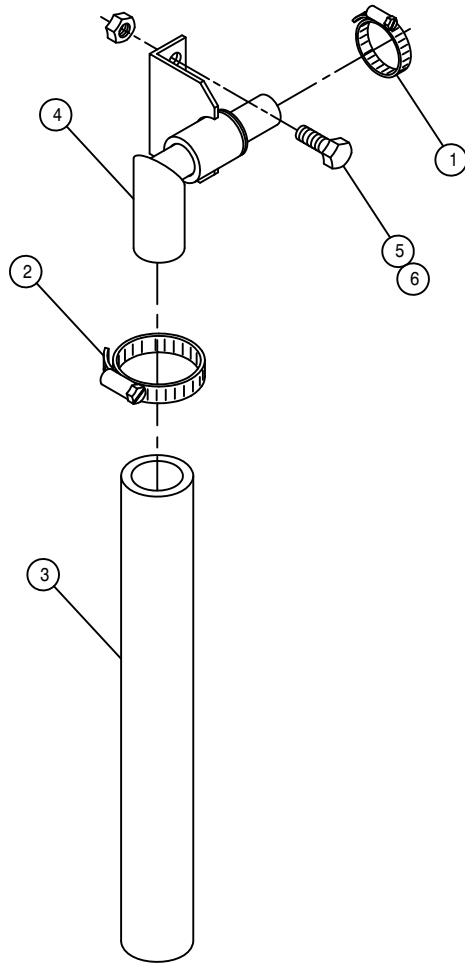

FOAMER DROP HOSE ASSEMBLY

DET. QTY PART NO. DESCRIPTION

1	1	520055	HOSE CLAMP NO 12	STAINLESS
2	1	520085	HOSE CLAMP NO 24	STAINLESS
3	1	601367	HOSE, 1 1/4 X 24	2BR BLK EPDM
4	1	701194	FOAMER DROP HOSE SWIVEL WLD	
5	2	900129	3/8UNC X 1"	HEX BOLT
6	2	914004	3/8UNC HEX STOVER NUT	

BOOM INDICATOR LIGHT ASSEMBLY

DET. QTY PART NO. DESCRIPTION

DET.	QTY	PART NO.	DESCRIPTION
1	1	164503	BOOM INDICATOR LIGHT MT
2	7	293516	2-WIRE PIGTAIL ASSY
3	7	291713	MTG BRKT FOR 291710/291711
4	2	291711	YELLOW LAMP, 3 3/8" OVAL 12.8V
5	5	291710	RED LAMP, 3 3/8" OVAL 12.8V
6	14	903889	10-32 X 3/4 SLT RDHD MACH SCR
7	14	470175	10-32 HEX FLANGE LOCK NUT
8	2	470118	1/4UNC X 3/4 FLANGE HEX BOLT
9	2	470121	1/4UNC HEX FLANGE LOCK NUT

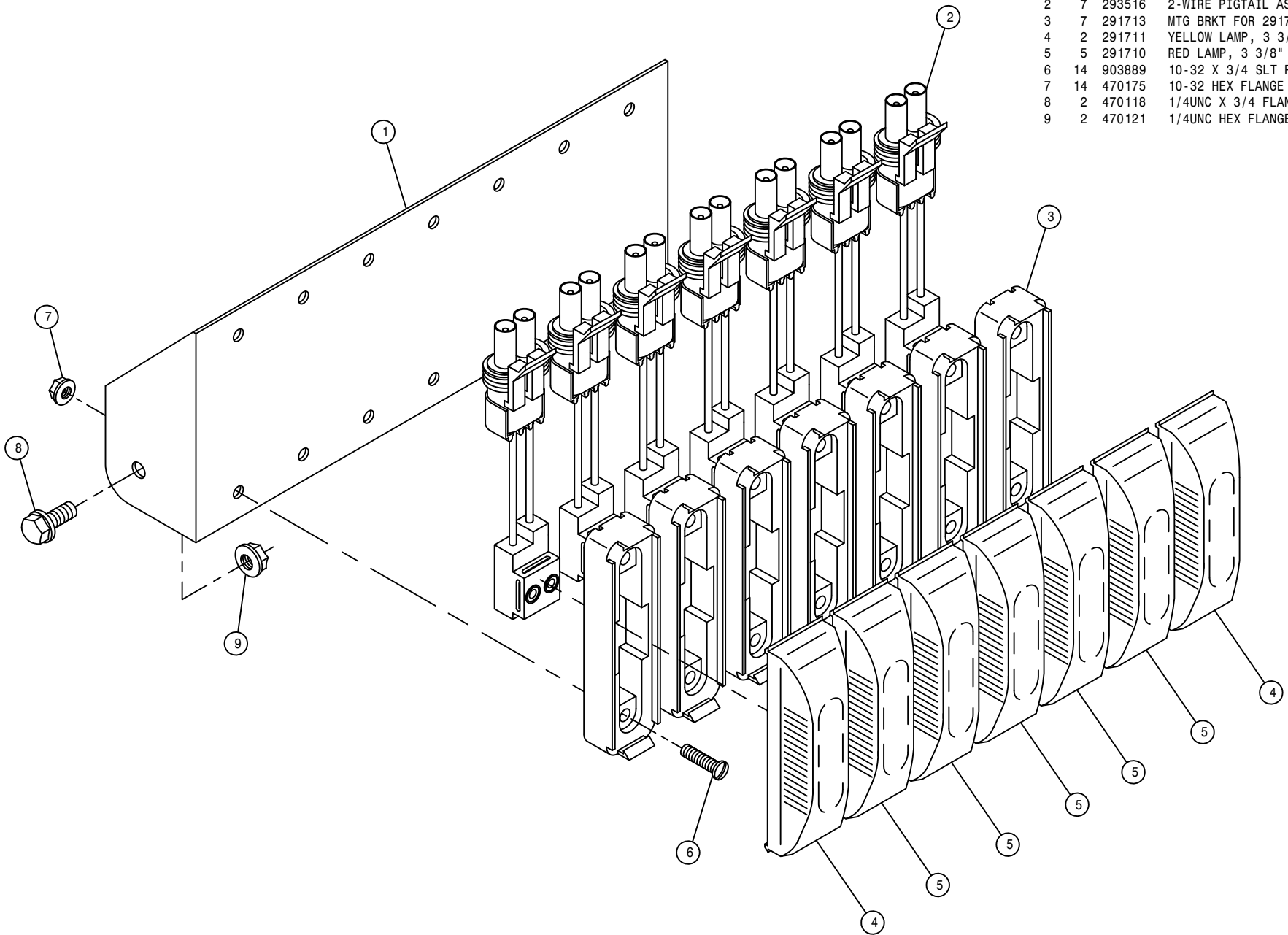

87

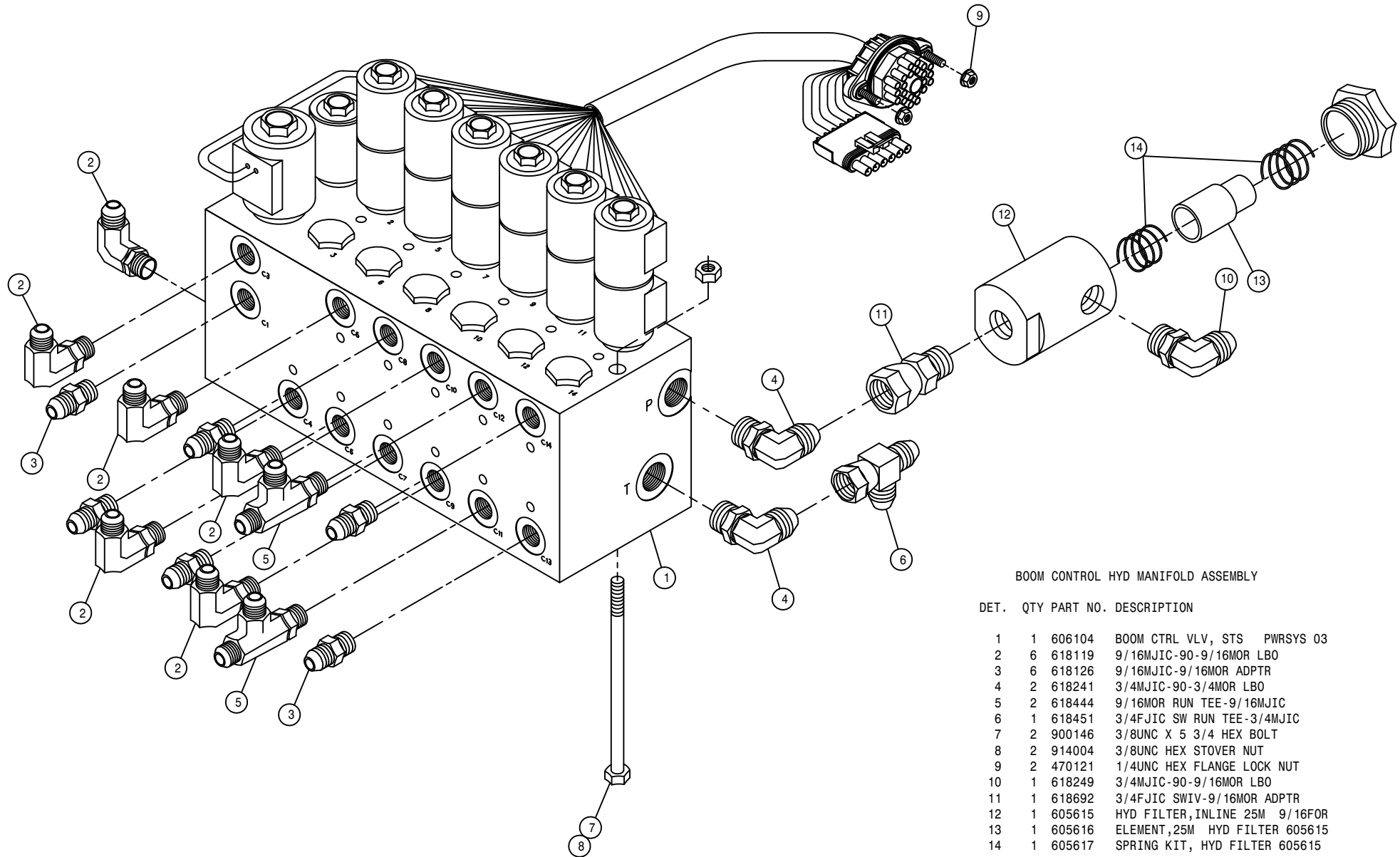

BOOM CONTROL HYD MANIFOLD ASSEMBLY

DET.	QTY	PART NO.	DESCRIPTION
1	1	606104	BOOM CTRL VLV, STS PWRSYS 03
2	6	618119	9/16MJIC-90-9/16MOR LBO
3	6	618126	9/16MJIC-9/16MOR ADPTR
4	2	618241	3/4MJIC-90-3/4MOR LBO
5	2	618444	9/16MOR RUN TEE-9/16MJIC
6	1	618451	3/4FJIC SW RUN TEE-3/4MJIC
7	2	900146	3/8UNC X 5 3/4 HEX BOLT
8	2	914004	3/8UNC HEX STOVER NUT
9	2	470121	1/4UNC HEX FLANGE LOCK NUT
10	1	618249	3/4MJIC-90-9/16MOR LBO
11	1	618692	3/4FJIC SWIV-9/16MOR ADPTR
12	1	605615	HYD FILTER, INLINE 25M 9/16FOR
13	1	605616	ELEMENT, 25M HYD FILTER 605615
14	1	605617	SPRING KIT, HYD FILTER 605615

LIFTARM ASSEMBLY

DET. QTY PART NO. DESCRIPTION

1	15	470287	TUBE CLAMP, .375-.375 (PAIR)
2	12	900086	5/16UNC X 2 1/4 HEX BOLT
3	1	615761	LIFT RAISE HYD TUBE ASSY
4	1	615762	LIFT LOWER HYD TUBE ASSY
5	1	615764	LEVEL LOWER HYD TUBE ASSY
6	1	615763	LEVEL RAISE HYD TUBE ASSY
7	2	615765	BREAKAWAY HYD TUBE ASSY
8	1	615767	BOOM EXTN LOWER HYD TUBE ASSY
9	1	615766	BOOM EXTN RAISE HYD TUBE ASSY
10	1	615769	RH FOLD LOWER HYD TUBE ASSY
11	1	615768	RH FOLD RAISE HYD TUBE ASSY
12	2	618019	9/16MJIC UNION TEE
13	2	618618	9/16MJIC-90-9/16FJIC SWIV LBO
14	10	619010	9/16MJIC UNION
15	3	900016	1/4UNC X 4 1/2 HEX BOLT
16	16	900403	3/4UNC X 2" HEX BOLT
17	4	910012	3/4UNC HEX NUT
18	3	914000	1/4UNC HEX STOVER NUT
19	12	914012	3/4UNC HEX STOVER NUT
20	4	920506	3/4 LOCK WASHER
21	2	164725	QUICK ATTACH PLT WLD STS 03
22	12	164452	LIFT ARM MT PIVOT PIN, STS12 00
23	1	164432	UPPER LIFT ARM WLD
24	8	121107	LIFTARM BEARING, ORKOT
25	4	121109	LIFT CYL BRG, ORKOT
26	2	621067	BOOM LIFT CYL ASSY STS 03
27	2	164450	LWR LIFTARM WLD
28	12	914002	5/16UNC HEX STOVER NUT

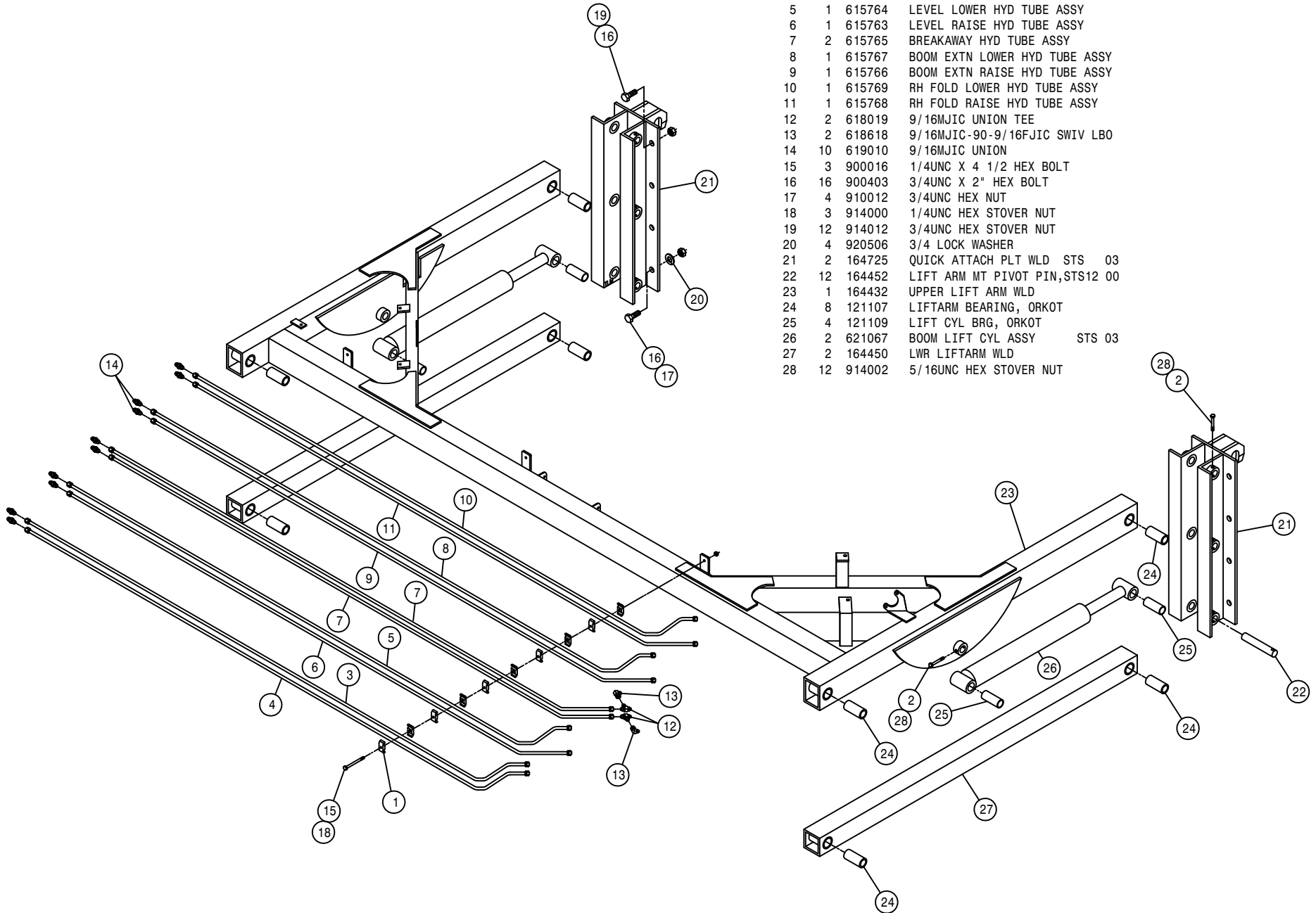

TRANSOM ASSEMBLY

DET. QTY PART NO. DESCRIPTION

DET.	QTY	PART NO.	DESCRIPTION
1	4	470012	COTTER PIN 5/16 X 2" LG,316 SS
2	4	121029	JOURNAL BRG, 1.00 ID X 1.00 LG
3	4	470329	3/8UNC X 1 1/4 FLANGE HEX BOLT
4	16	473842	1/4UNC LOCK NUT,CNTR POINT SS
5	8	473979	.25UNC-1.12ID-1.50U-BOLT SQ SS
6	2	900284	1/2UNC X 4 3/4 HEX BOLT
7	2	914008	1/2UNC HEX STOVER NUT
8	1	164661	TRANSOM WLD STS12 2001
9	1	164469	RH TRANSOM PIVOT TUBE WLD
10	2	164481	INNER TRANSOM PIVOT TUBE
11	2	121103	TRANSOM PIVOT BRG, LWR ORKOT
12	1	164470	LH TRANSOM PIVOT TUBE WLD
13	4	121104	BOOM PIVOT BEARING, ORKOT
14	2	164482	TRANSOM PIVOT WASHER
15	6	164483	FOLD CYL STOP SPACER, 16 GA
16	2	164484	FOLD CYL STOP SPACER, .500
17	1	164485	HOSE SUPPORT WLD
18	2	164664	FOLD CYL TRUNION MT WLD 2001
19	2	164491	NOZL MT TUBE, TRANSOM STS12
20	2	121101	TRANSOM PIVOT BRG,TOP ORKOT
21	2	470326	ACCUMULATOR, DIAPHRAGM
22	2	618673	3/4MOR BRANCH TEE-9/16MJIC
23	8	914004	3/8UNC HEX STOVER NUT
24	2	164493	ACCUMULATOR MT WLD
25	2	164498	BOOM FOLD CYL PIN WLD
26	2	164496	LEVEL CYL PIN WLD, TRANSOM END
27	4	920008	1" SAE FLAT WASHER
28	2	621068	BOOM LEVEL CYL ASSY 3.00"STS03
29	2	621069	BOOM FOLD CYL ASSY STS 03
30	8	900333	5/8UNC X 1 1/2 HEX BOLT
31	2	900129	3/8UNC X 1" HEX BOLT
32	2	900130	3/8UNC X 1 1/4 HEX BOLT
33	4	629727	FINISH PLUG FOR 1 IN X 16 GA
34	2	164641	BOOM PIVOT BRG SPACER STS12
35	2	164642	TRANSOM PIVOT BRG SPACER STS12
36	8	914010	5/8UNC HEX STOVER NUT

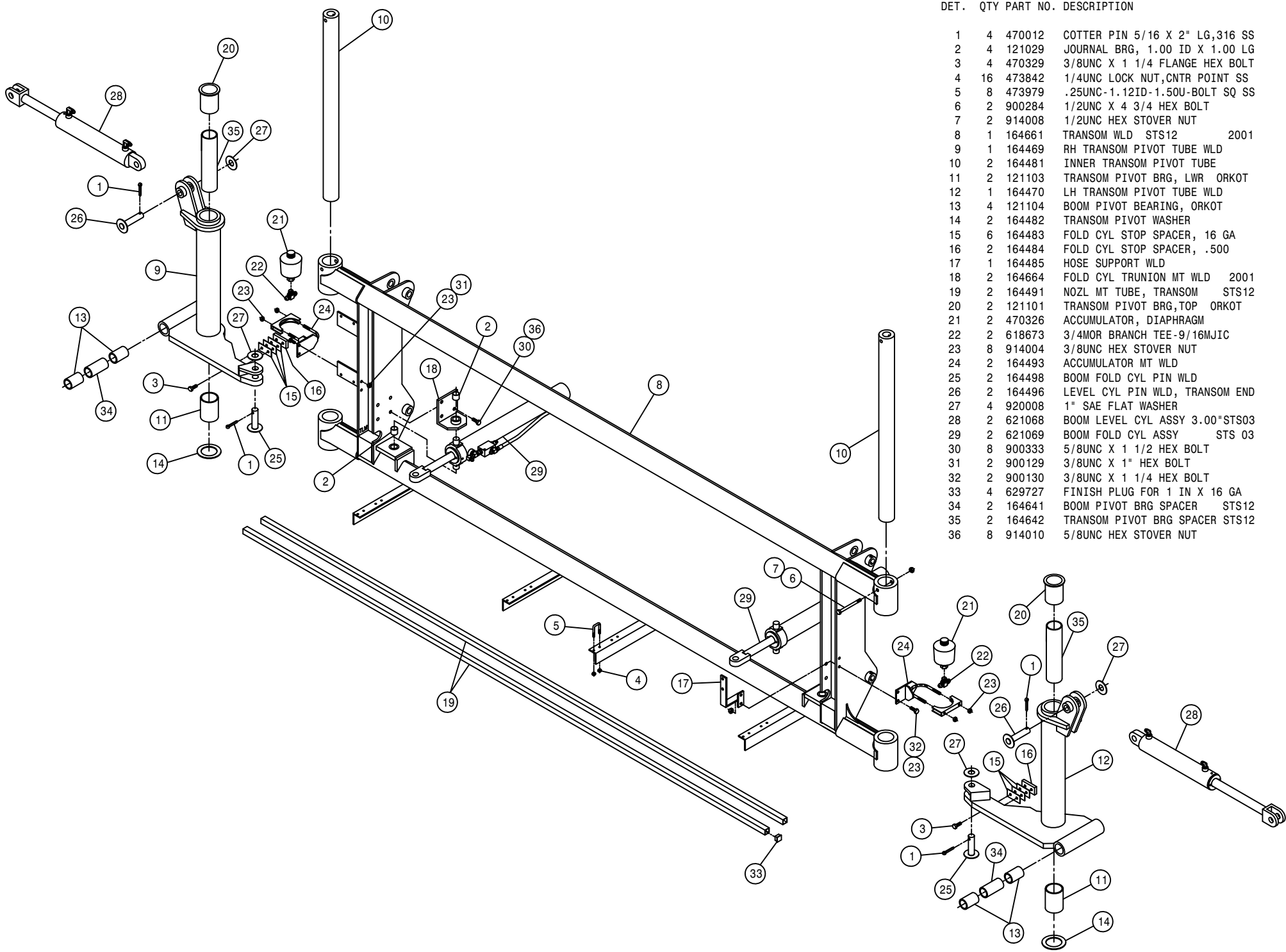

90

272090

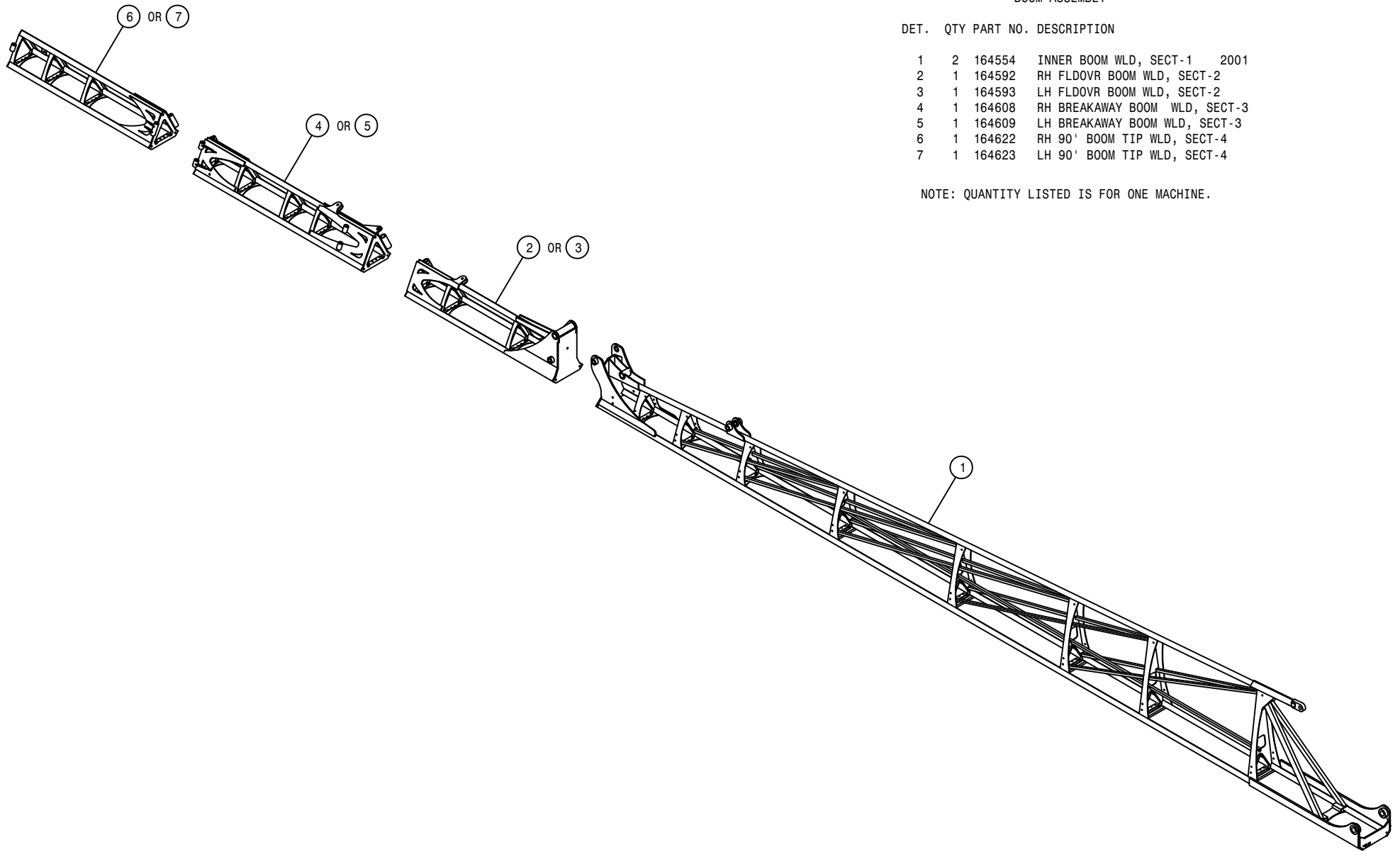

BOOM ASSEMBLY

DET.	QTY	PART NO.	DESCRIPTION
1	2	164554	INNER BOOM WLD, SECT-1 2001
2	1	164592	RH FLDOVR BOOM WLD, SECT-2
3	1	164593	LH FLDOVR BOOM WLD, SECT-2
4	1	164608	RH BREAKAWAY BOOM WLD, SECT-3
5	1	164609	LH BREAKAWAY BOOM WLD, SECT-3
6	1	164622	RH 90' BOOM TIP WLD, SECT-4
7	1	164623	LH 90' BOOM TIP WLD, SECT-4

NOTE: QUANTITY LISTED IS FOR ONE MACHINE.

INNER BOOM ASSEMBLY

DET. QTY PART NO. DESCRIPTION

1	2	164554	INNER BOOM WLD, SECT-1	2001
2	28	470287	TUBE CLAMP, .375-.375 (PAIR)	
3	36	473842	1/4UNC LOCK NUT,CNTR POINT SS	
4	18	473979	.25UNC-1.12ID-1.50U-BOLT SQ SS	
5	8	615760	BOOM HYD TUBE ASSY	
6	16	619010	9/16MJIC UNION	
7	4	629727	FINISH PLUG FOR 1 IN X 16 GA	
8	12	900007	1/4UNC X 2" HEX BOLT	
9	14	914000	1/4UNC HEX STOVER NUT	
10	2	164515	BOOM HINGE PIN WLD	
11	2	164547	NOZL MT TUBE, BOOM SECT-1 (A)	
12	2	164548	NOZL MT TUBE WLD, SECT-1 (B)	
13	2	164500	LEVEL CYL PIN WLD, SHAFT END	
14	2	900073	5/16UNC X 3 1/4 HEX BOLT	
15	2	470012	COTTER PIN 5/16 X 2" LG,316 SS	
16	2	914002	5/16UNC HEX STOVER NUT	
17	2	900027	1/4UNC X 5" HEX BOLT	
18	2	920008	1" SAE FLAT WASHER	

NOTE: QUANTITY LISTED IS FOR ONE MACHINE.

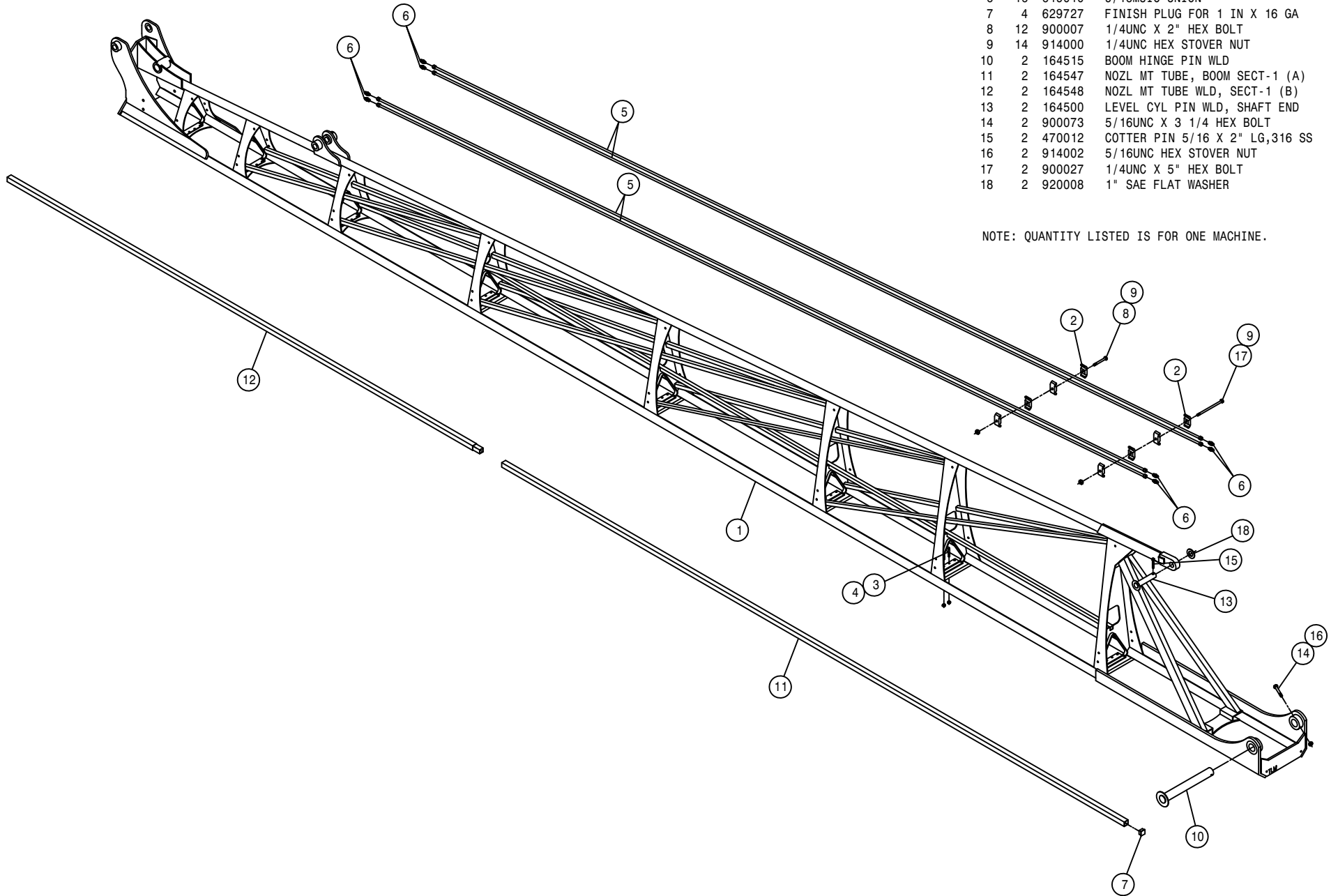

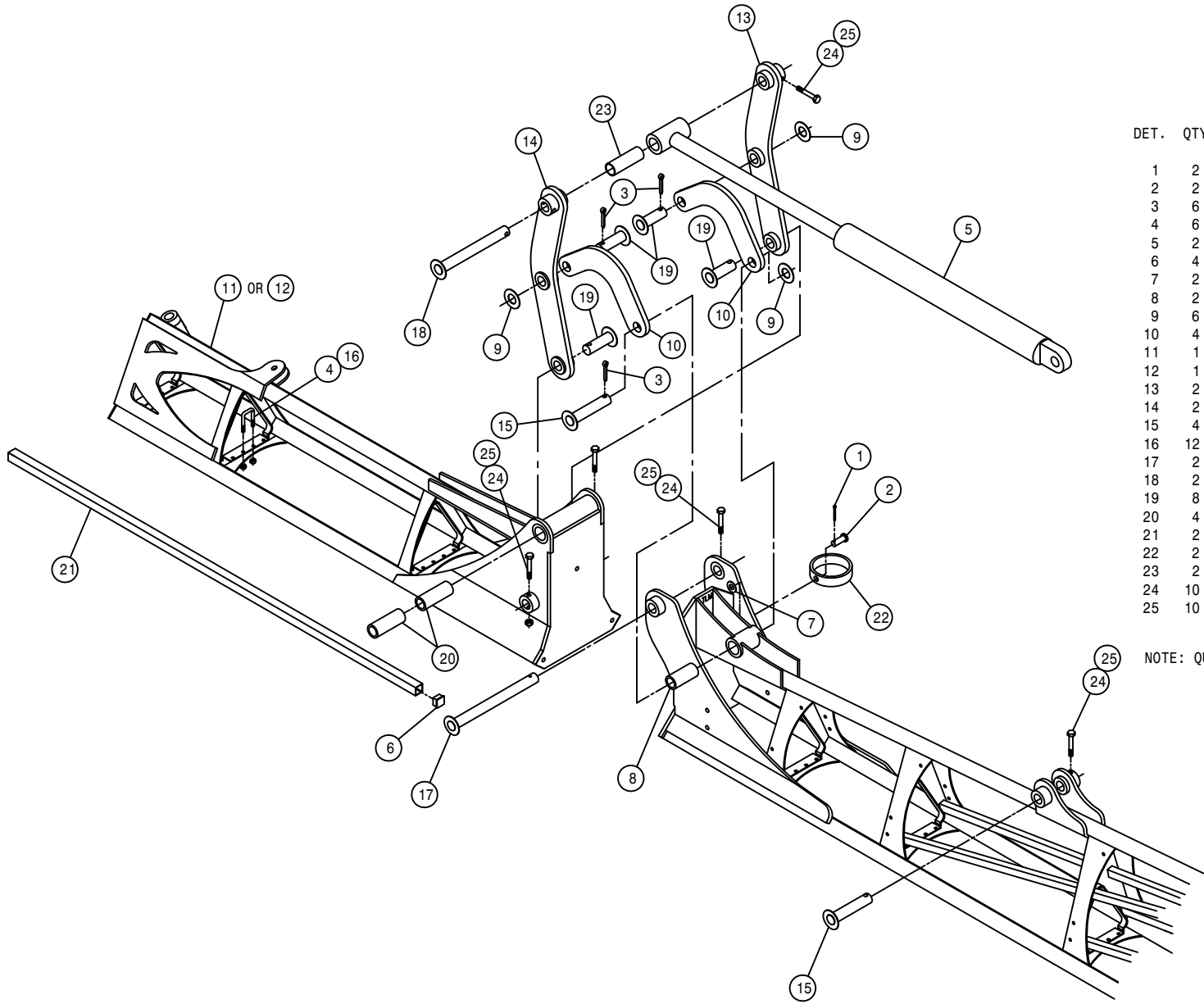

80' - 90' BOOM HINGE ASSEMBLY

DET.	QTY	PART NO.	DESCRIPTION
	2	390984	COTTER PIN 1/8 X 1 1/4
	2	472277	CLEVIS PIN, .50 X 1.25LG PLT
	6	470012	COTTER PIN 5/16 X 2" LG, 316 SS
	6	473979	.25UNC-1.12ID-1.50U-BOLT SQ SS
	2	621070	OUTR BOOM FOLD CYL ASSY STS 03
	4	629727	FINISH PLUG FOR 1 IN X 16 GA
	2	920004	1/2 SAE FLAT WASHER
	2	121107	LIFTARM BEARING, ORKOT
	6	920008	1" SAE FLAT WASHER
	4	164643	XK402 TOP ARM (LEFT) 10.35 CNTR
	1	164592	RH FLDOVR BOOM WLD, SECT-2
	1	164593	LH FLDOVR BOOM WLD, SECT-2
	2	164528	RH FOLD-OVER BOOMERANG WLD
	2	164529	LH FOLD-OVER BOOMERANG WLD
	4	164522	BOOM FOLD CYL PIN WLD
	12	473842	1/4UNC LOCK NUT, CNTR POINT SS
	2	164518	BOOM FOLD PIVOT PIN WLD
	2	164520	BOOM CYL PIVOT PIN WLD
	8	164524	BOOMERANG CNTR PIVOT PIN WLD
	4	121106	BOOM FOLD BRG, ORKOT
	2	164551	NOZL MT TUBE, BOOM SECT-2
	2	164517	HOSE SUPPORT RING
	2	121108	OUTR BOOM FOLD CYL BRG, ORKOT
	10	900086	5/16UNC X 2 1/4 HEX BOLT
	10	914002	5/16UNC HEX STOVER NUT

NOTE: QUANTITY LISTED IS FOR ONE MACHINE.

BOOM BREAKAWAY ASSEMBLY

DET. QTY PART NO. DESCRIPTION

DET.	QTY	PART NO.	DESCRIPTION
1	36	473842	1/4UNC LOCK NUT,CNTR POINT SS
2	18	473979	.25UNC-1.12ID-1.50U-BOLT SQ SS
3	6	470011	COTTER PIN 5/32 X 1 1/2,316 SS
4	2	621066	BOOM BREAKAWAY CYL ASSY STS 03
5	8	629727	FINISH PLUG FOR 1 IN X 16 GA
6	1	164592	RH FLDOVR BOOM WLD, SECT-2
7	1	164593	LH FLDOVR BOOM WLD, SECT-2
8	1	164608	RH BREAKAWAY BOOM WLD, SECT-3
9	1	164609	LH BREAKAWAY BOOM WLD, SECT-3
10	1	164622	RH 90' BOOM TIP WLD, SECT-4
11	1	164623	LH 90' BOOM TIP WLD, SECT-4
12	4	164637	BOOM TIP SECTION PIN WLD
13	8	121110	BREAKAWAY BRG, ORKOT
14	2	164553	NOZL MT TUBE, BOOM SECT-4
15	2	164552	NOZL MT TUBE, BOOM SECT-3
16	2	900265	1/2UNC X 1 1/2 HEX BOLT
17	2	900267	1/2UNC X 2" HEX BOLT
18	4	914008	1/2UNC HEX STOVER NUT
19	2	164526	BOOM BREAKAWAY PIVOT PIN WLD

NOTE: QUANTITY LISTED IS FOR ONE MACHINE.

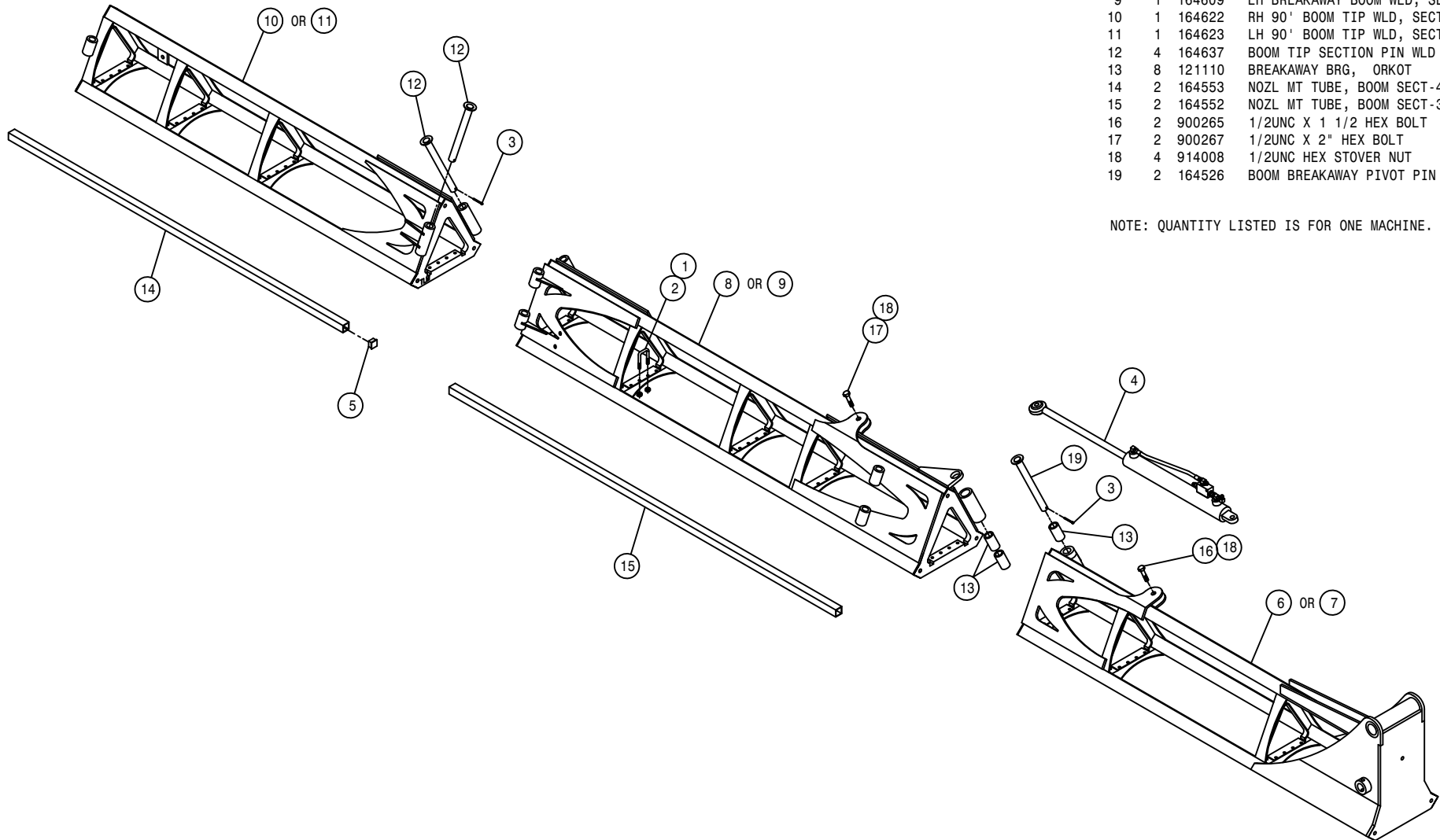

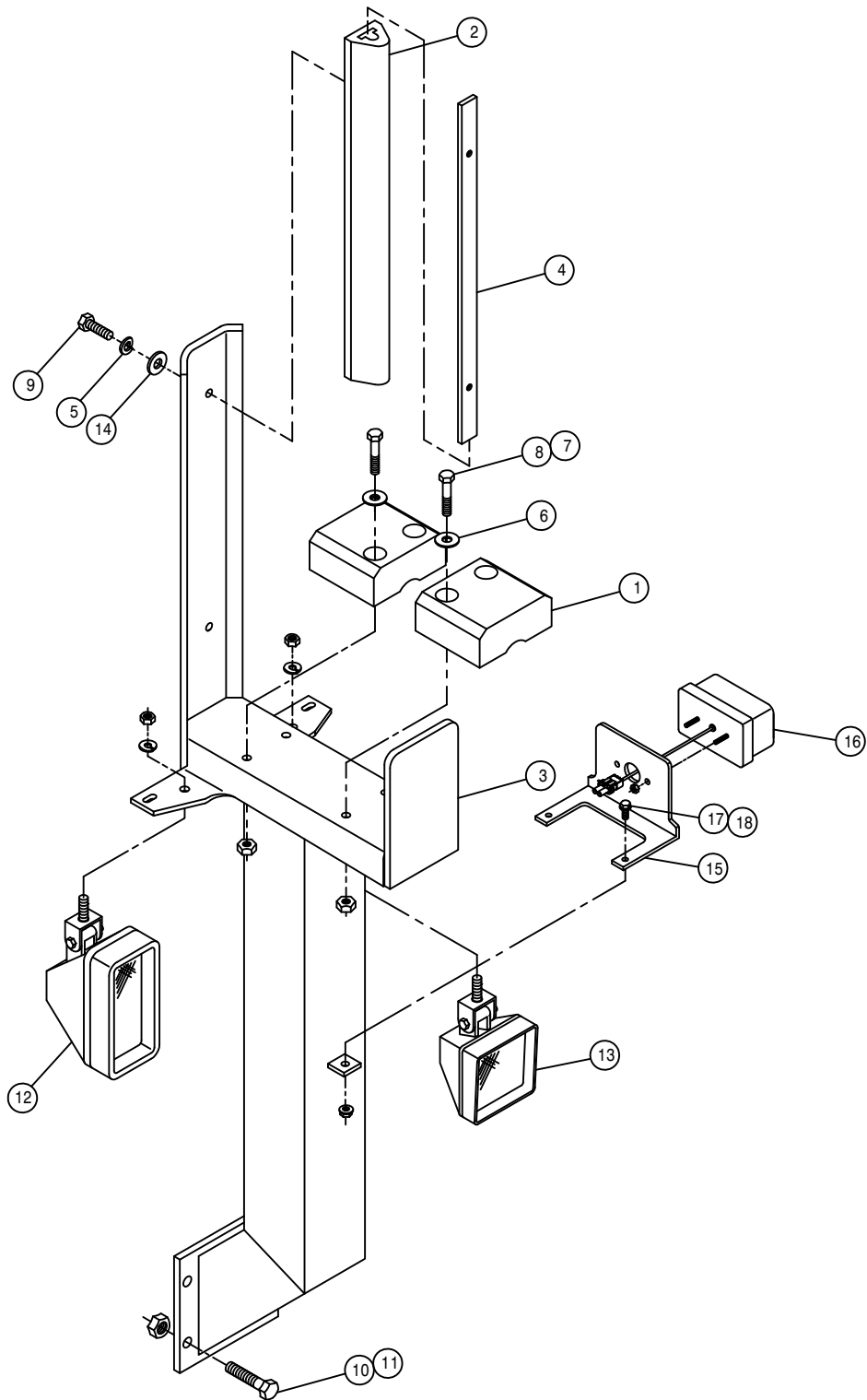

BOOM CRADLE ASSEMBLY

DET.	QTY	PART NO.	DESCRIPTION
1	4	164513	BOOM CRADLE PAD
2	2	164512	RUBBER BUMPER, BOOM CRADLE
3	2	164505	BOOM CRADLE WLD
4	2	164514	RUBBER BUMPER KEEPER PLT
5	4	920501	5/16 LOCK WASHER
6	8	920002	3/8 SAE FLAT WASHER
7	8	914004	3/8UNC HEX STOVER NUT
8	8	900133	3/8UNC X 2" HEX BOLT
9	4	900066	5/16UNC X 1 1/4 HEX BOLT
10	8	900265	1/2UNC X 1 1/2 HEX BOLT
11	4	914008	1/2UNC HEX STOVER NUT
12	2	291779	HALOGEN WORKLAMP, LH MT 12V55W
13	2	291780	HALOGEN WORKLAMP, CNTR MT12V55W
14	4	920001	5/16 SAE FLAT WASHER
15	2	342799	EXTREMITY FLASHER MT, STS 03
16	2	293404	FRT TURN/WARN LITE ASSY2100 98
17	4	470118	1/4UNC X 3/4 FLANGE HEX BOLT
18	4	470121	1/4UNC HEX FLANGE LOCK NUT

*NOTE: QUANTITY LISTED IS FOR ONE MACHINE.

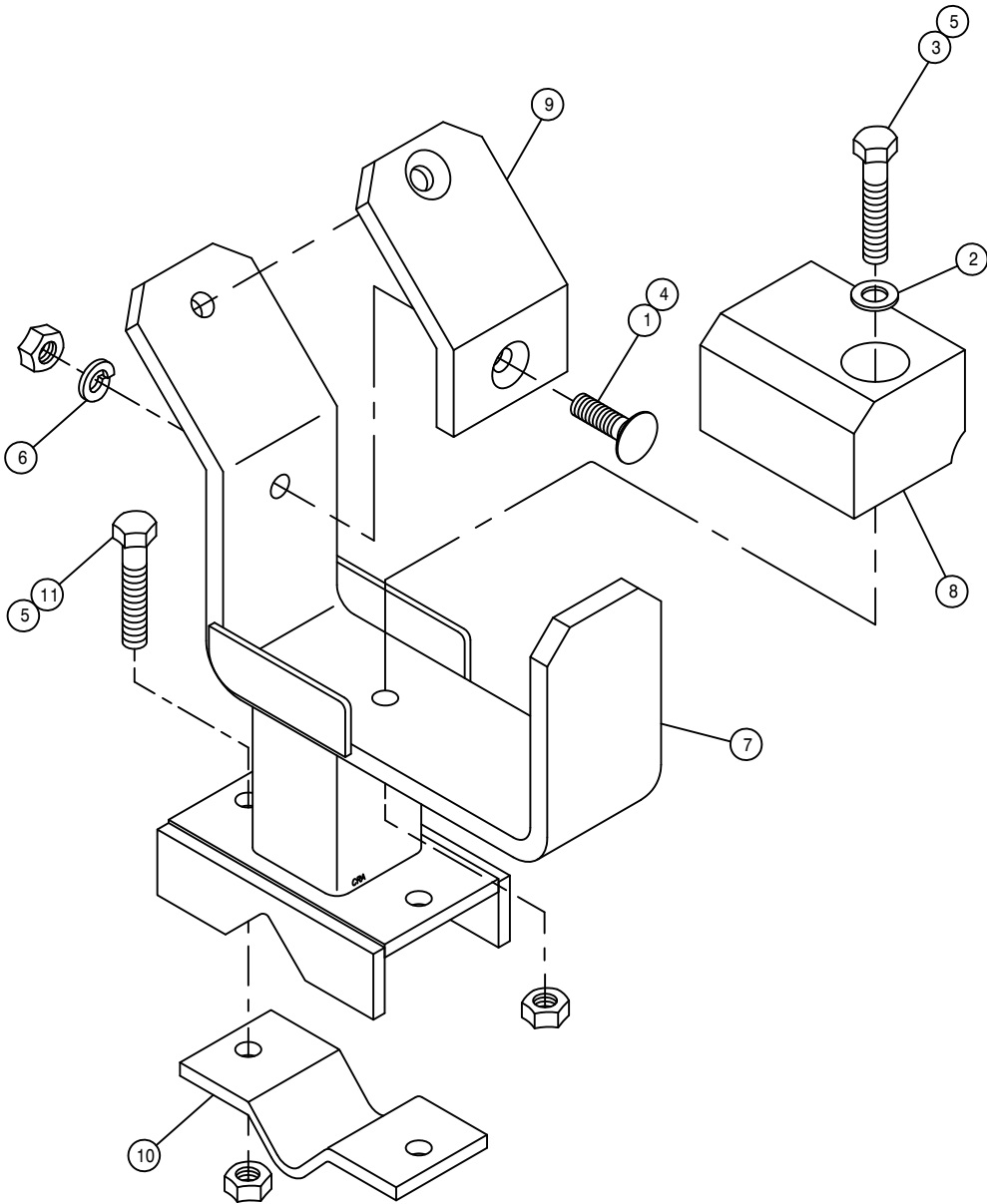

BOOM SUPPORT CRADLE ASSEMBLY, 80' -90'

DET. QTY PART NO. DESCRIPTION

DET.	QTY	PART NO.	DESCRIPTION
1	2	470328	3/8UNC X 1 1/4 #3HD PLOW BOLT
2	1	483043	3/8 REGULAR FLAT WASHER
3	1	900133	3/8UNC X 2" HEX BOLT
4	2	910004	3/8UNC HEX NUT
5	3	914004	3/8UNC HEX STOVER NUT
6	2	920502	3/8 LOCK WASHER
7	1	164535	BOOM SUPPORT CRADLE WLD,80/90'
8	1	164541	BOOM SUPPORT PAD
9	1	164542	BOOM SUPPORT CRADLE PAD
10	1	164543	BOOM SUPPORT KEEPER
11	2	900170	3/8UNC X 2 1/4 HEX BOLT

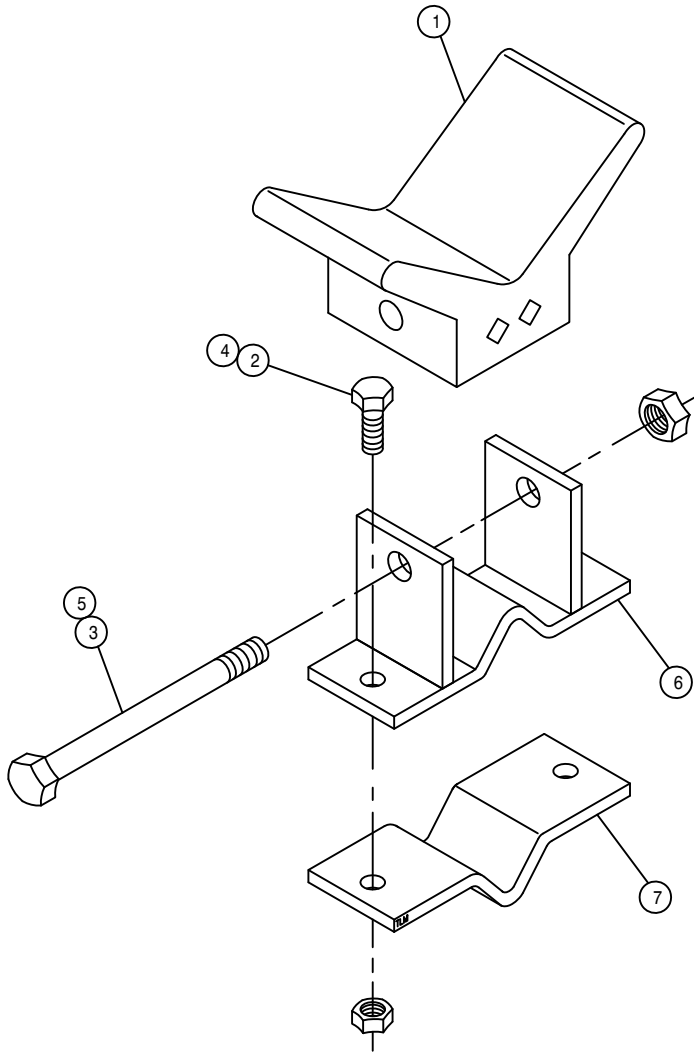

90' BOOM SUPPORT ASSEMBLY

DET.	QTY	PART NO.	DESCRIPTION
1	1	470324	3" RUBBER BOW GUARD
2	2	900130	3/8UNC X 1 1/4 HEX BOLT
3	1	900273	1/2UNC X 3 3/4 HEX BOLT
4	2	914004	3/8UNC HEX STOVER NUT
5	1	914008	1/2UNC HEX STOVER NUT
6	1	164544	FRT BOOM SUPPORT WLD, 90' BOOM
7	1	164545	FRT BOOM SUPPORT MT

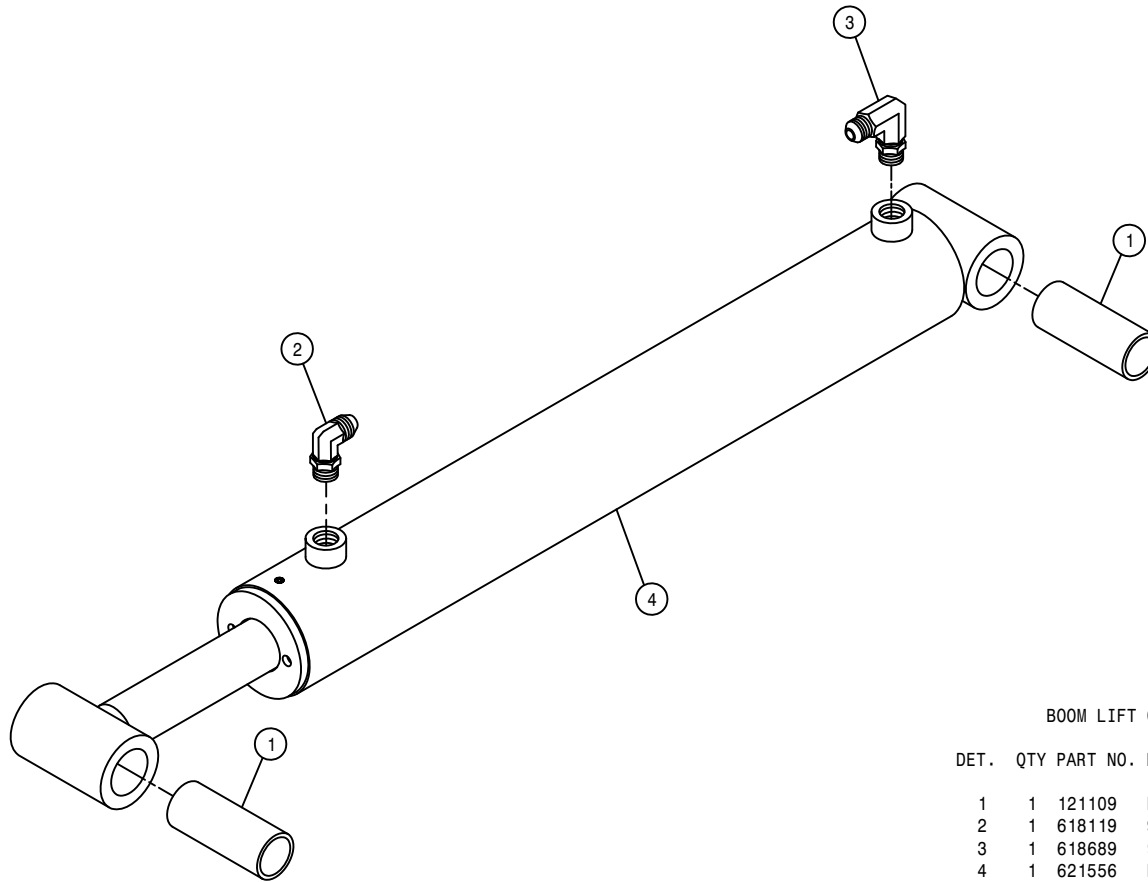

BOOM LIFT CYLINDER ASSEMBLY

DET.	QTY	PART NO.	DESCRIPTION
1	1	121109	LIFT CYL BRG, ORKOT
2	1	618119	9/16MJIC-90-9/16MOR LBO
3	1	618689	9/16MOR-90-9/16MJ .042 CHK VLV
4	1	621556	LIFT CYL, 2.50 X 18.00 STS
NS	1	621557	REPAIR KIT, HYD CYL 621556

NOTE: 621067 - BOOM LIFTARM CYLINDER ASSEMBLY WITH FITTINGS

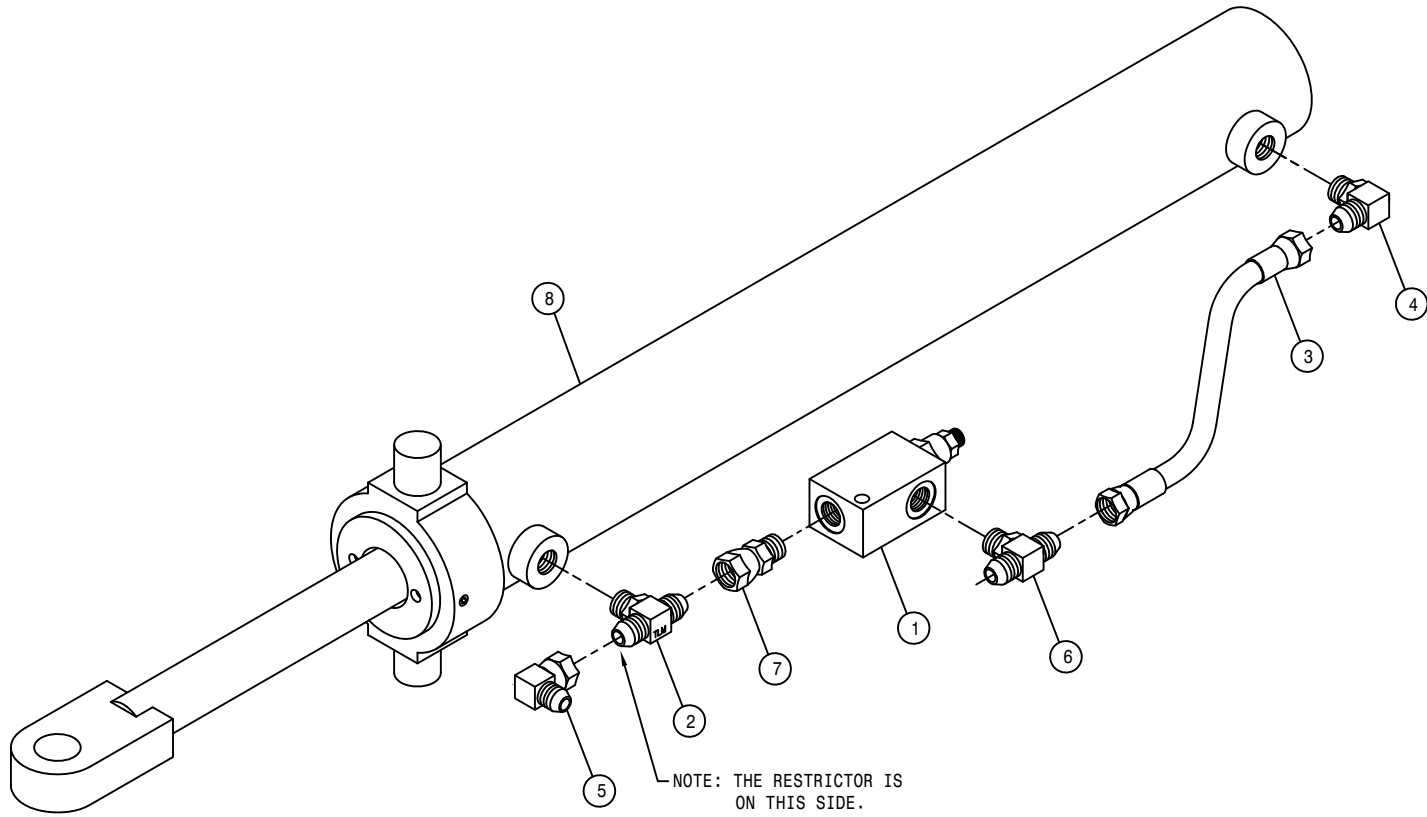

NOTE: THE RESTRICTOR IS ON THIS SIDE.

BOOM FOLD CYLINDER ASSEMBLY

DET.	QTY	PART NO.	DESCRIPTION
1	1	607541	KICK-DOWN RELIEF VALVE,4500PSI
2	1	614756	RESTRICTOR BR TEE ASSY, .025DIA
3	1	616077	04-451TC-06FJX-06FJX-18 H/A
4	1	618119	9/16MJIC-90-9/16MOR LBO
5	1	618618	9/16MJIC-90-9/16FJIC SWIV LBO
6	1	618629	9/16MOR BRANCH TEE-9/16MJIC
7	1	618668	9/16FJIC SWIV-9/16MOR ADPTR
8	1	621560	FOLD CYL, 2.50 X 21.000 STS
NS	1	621561	REPAIR KIT, HYD CYL 621560

NOTE: 621069 - BOOM FOLD CYLINDER ASSEMBLY WITH FITTINGS

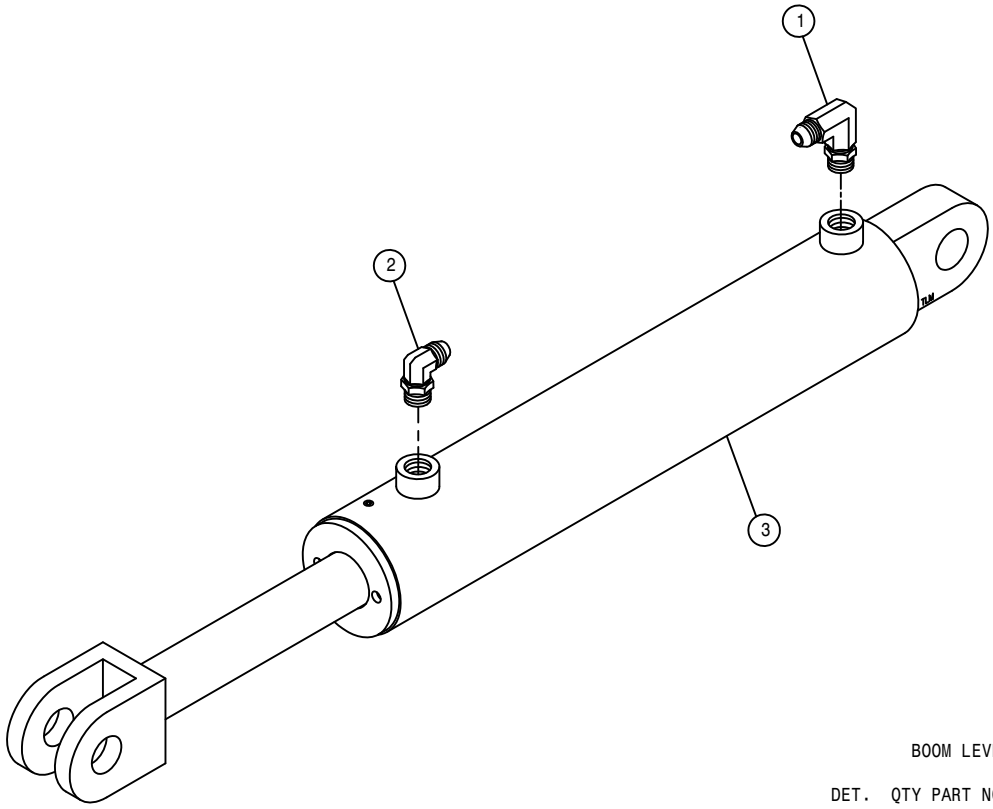

BOOM LEVEL CYLINDER ASSEMBLY

DET.	QTY	PART NO.	DESCRIPTION
	1	618119	9/16MJIC-90-9/16MOR LBO
	1	618689	9/16MOR-90-9/16MJ .042 CHK VLV
	1	621558	LEVEL CYL, 3.00 X 11.00 STS
NS	1	621559	REPAIR KIT, HYD CYL 621558

NOTE: 621068 - BOOM LEVEL CYLINDER ASSEMBLY WITH FITTINGS

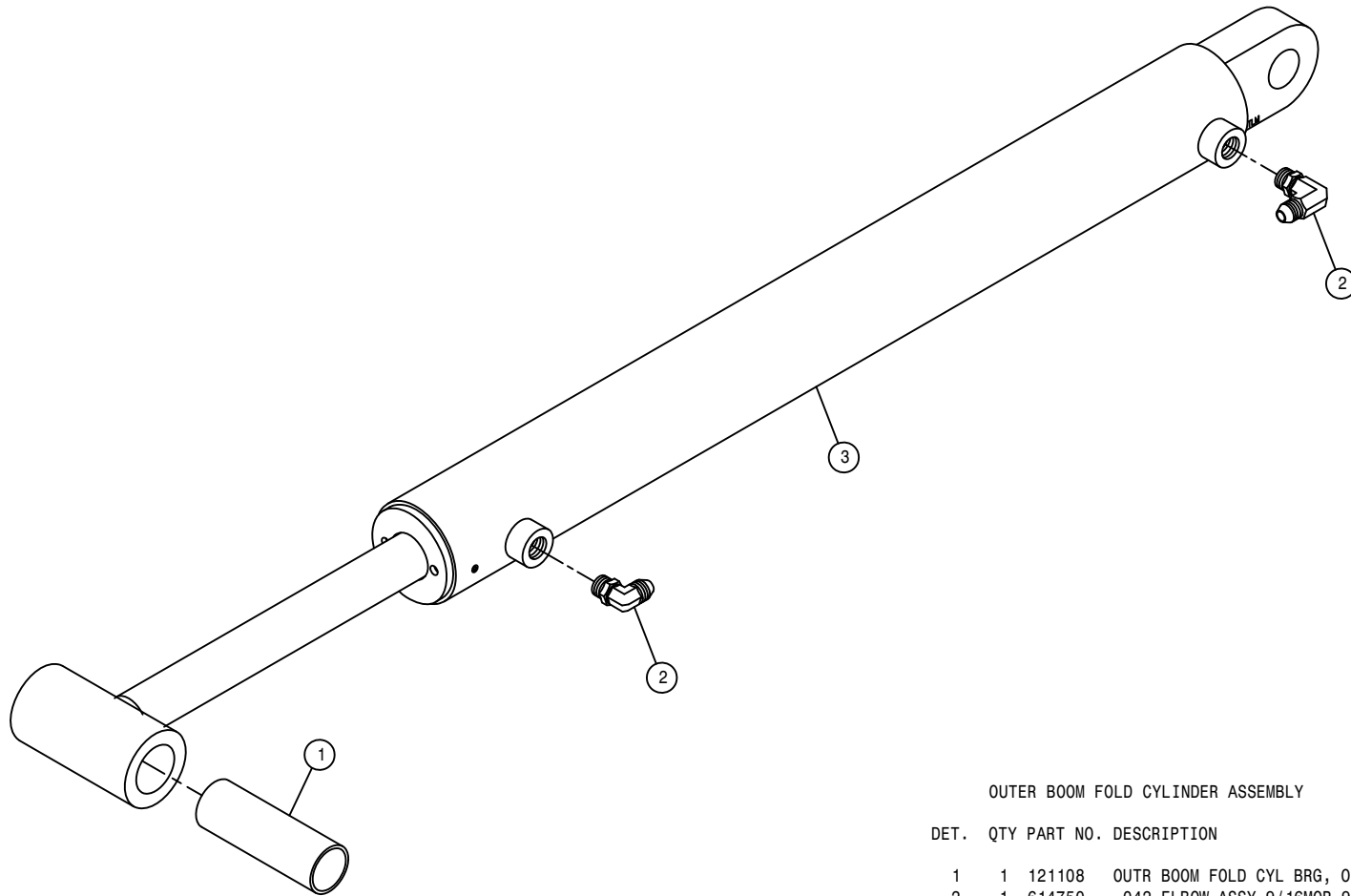

OUTER BOOM FOLD CYLINDER ASSEMBLY

DET. QTY PART NO. DESCRIPTION

1	1	121108	OUTR BOOM FOLD CYL BRG, ORKOT
2	1	614750	.042 ELBOW ASSY,9/16MOR 90D
3	1	621562	OUTR FOLD CYL,2.25 X 21.00 STS
NS	1	621563	REPAIR KIT,HYD CYL 621562

NOTE: 621070 - OUTER BOOM FOLD CYLINDER ASSEMBLY WITH FITTINGS

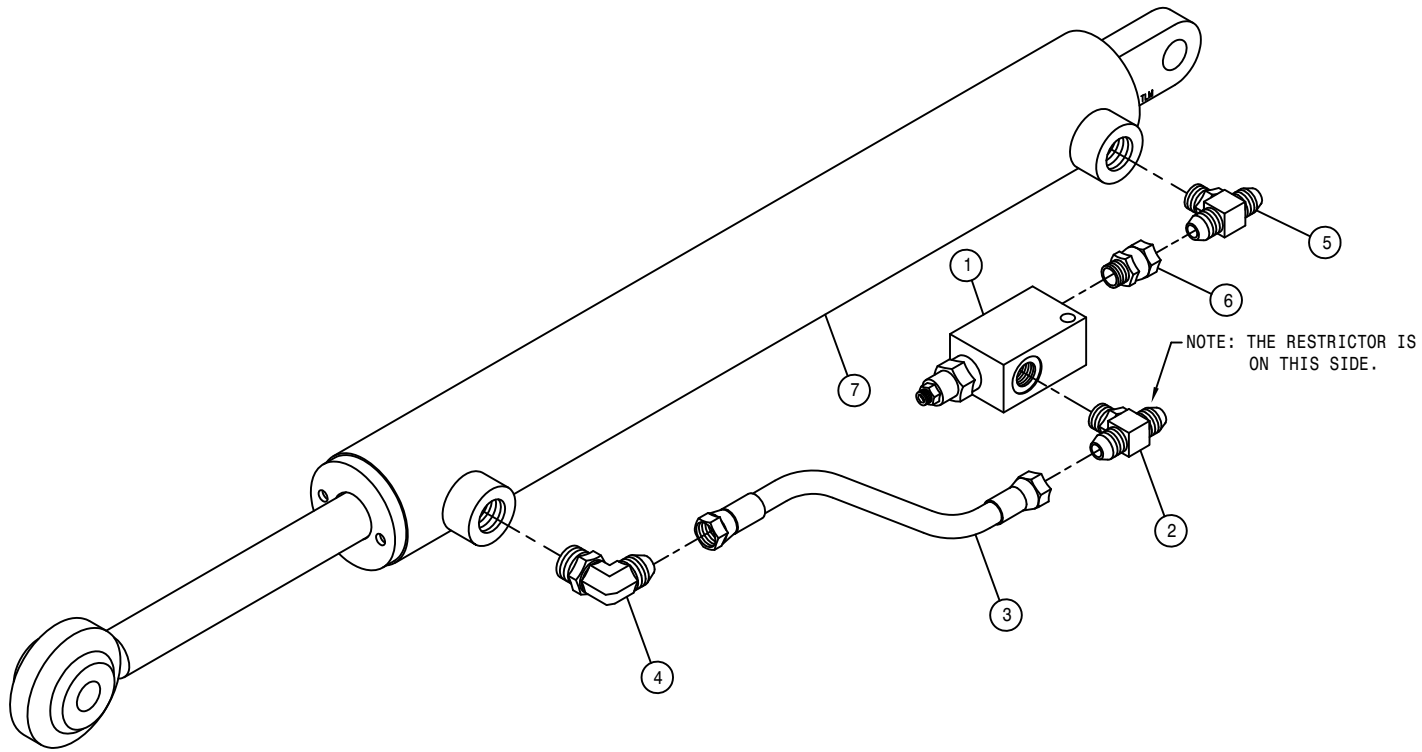

BOOM BREAKAWAY CYLINDER ASSEMBLY

DET.	QTY	PART NO.	DESCRIPTION
	1	607540	KICK-DOWN RELIEF VALVE, 800PSI
	1	614752	RESTRICTOR BR TEE ASSY, .042DIA
	1	616075	04-451TC-06FJX-06FJX-9 H/A
	1	618119	9/16MJIC-90-9/16MOR LBO
	1	618629	9/16MOR BRANCH TEE-9/16MJIC
	1	618668	9/16FJIC SWIV-9/16MOR ADPTR
	1	621554	LADR/SF/BRKWAY CYL, 1.50 X12.25
	1	621555	REPAIR KIT, HYD CYL 621554

NOTE: 621066 - BOOM BREAKAWAY CYLINDER ASSEMBLY WITH FITTINGS

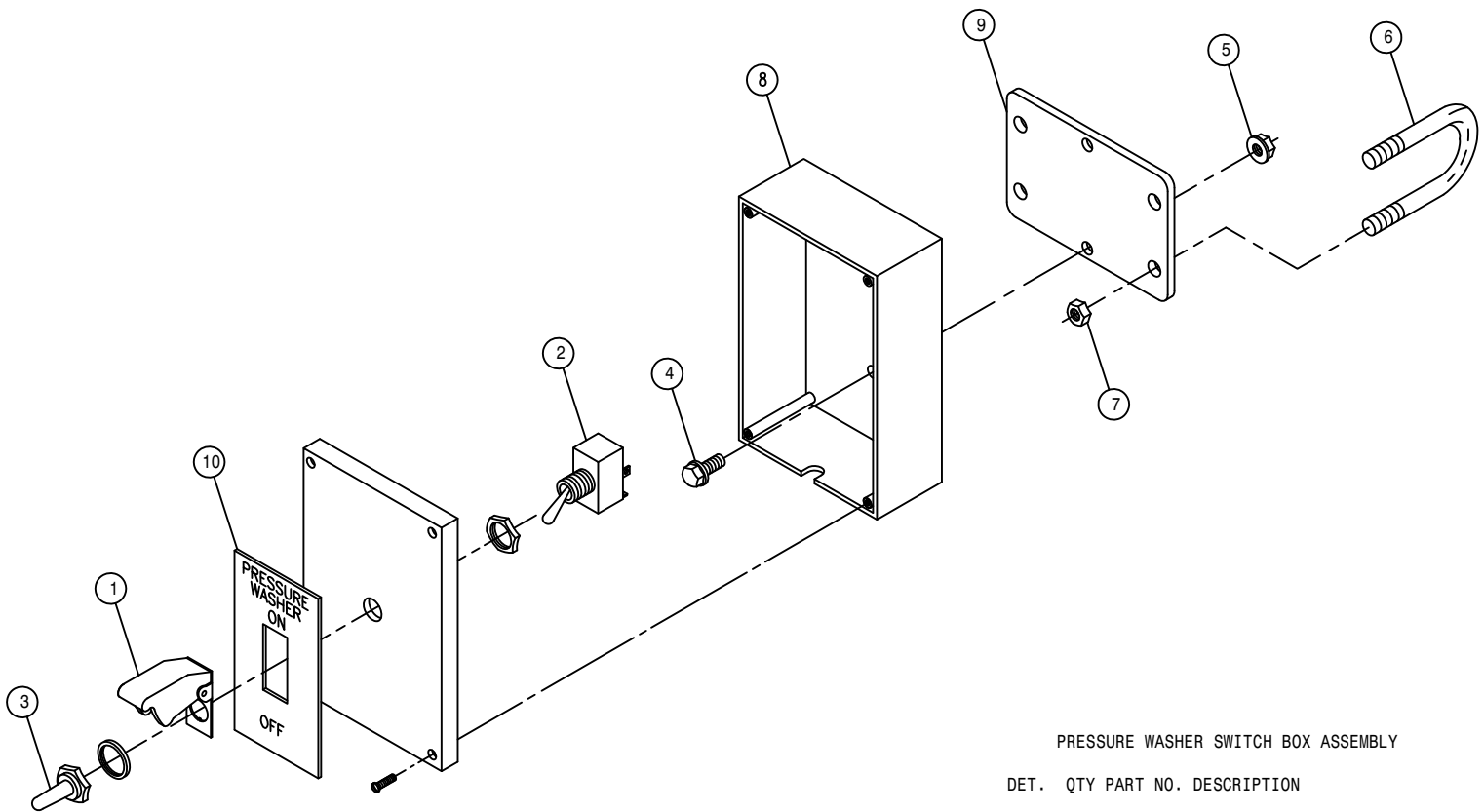

PRESSURE WASHER SWITCH BOX ASSEMBLY

DET.	QTY	PART NO.	DESCRIPTION
	1	291655	AIRCRAFT TOGGLE SWITCH GUARD
	1	291790	TOGGLE SWITCH, ON-OFF DPDT
	1	470001	RUBBER BOOT W NUT FOR 298012
	2	470118	1/4UNC X 3/4 FLANGE HEX BOLT
	2	470121	1/4UNC HEX FLANGE LOCK NUT
	2	473911	5/16UNC-1.31ID-2.00 U-BOLT
	4	910002	5/16UNC HEX NUT
	1	690738	PRESSURE WASHER SWITCH BOX
	1	690739	PRESSURE WASHER SWITCH BOX MT
	1	650110	DECAL,PRESSURE WASH CTRL,STS12

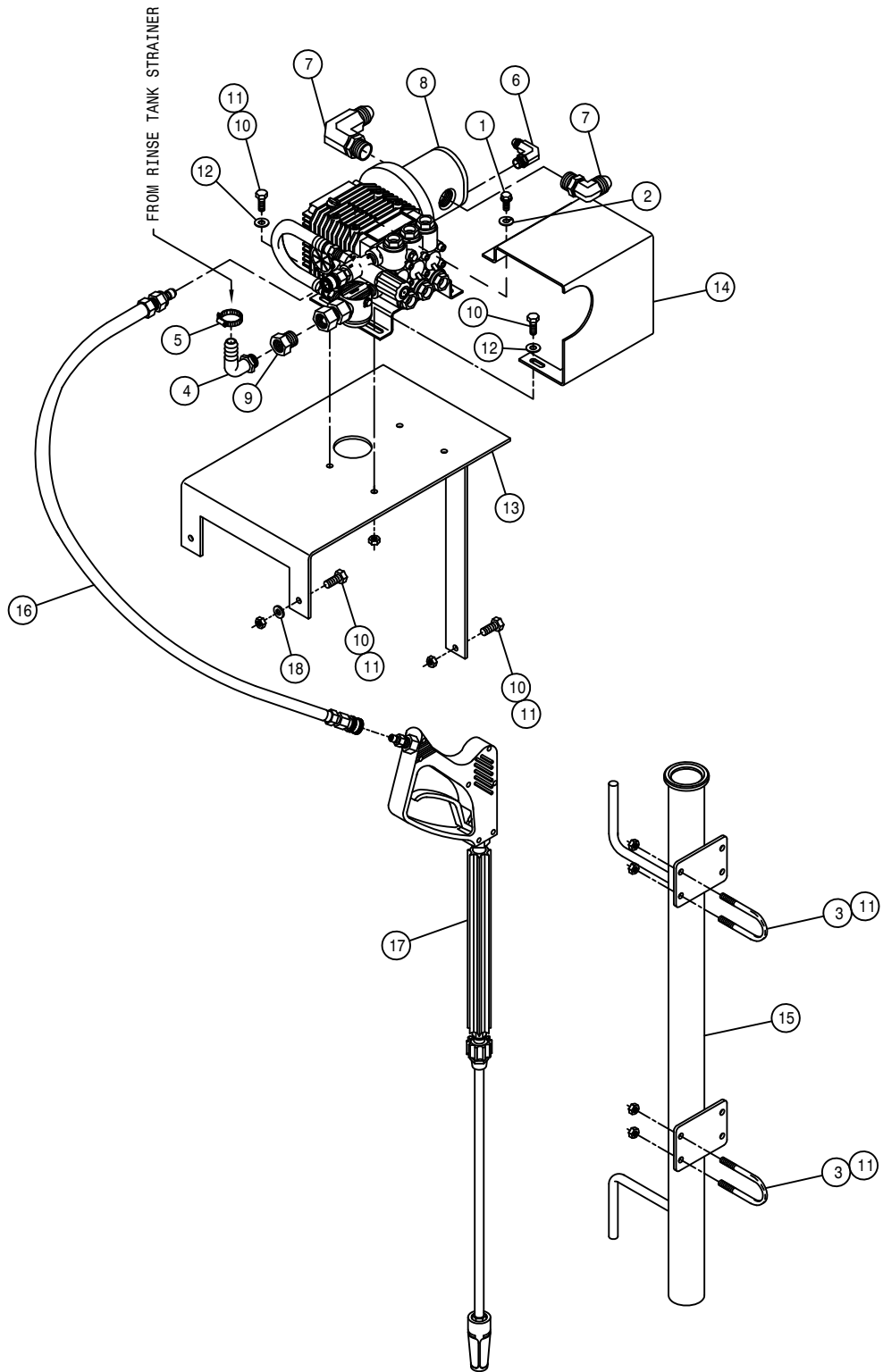

PRESSURE WASHER ASSEMBLY

DET. QTY PART NO. DESCRIPTION

1	2	473803	8MM-1.25 X 16MM HEX BOLT
2	2	473804	8MM LOCK WASHER
3	4	473911	5/16UNC-1.31ID-2.00 U-BOLT
4	1	500026	3/4NPT-90-1"HOSE BARB, POLY
5	1	520090	HOSE CLAMP NO 16 STAINLESS
6	1	618119	9/16MJIC-90-9/16MOR LBO
7	2	618474	3/4MJIC-90-1 1/16MOR LBO
8	1	690672	PRESSURE WASHER,PACE 320 HYD
9	1	715449	3/4FNPT X 3/4MGHT ADPTR BRS
10	7	900064	5/16UNC X 3/4 HEX BOLT
11	15	914002	5/16UNC HEX STOVER NUT
12	4	920001	5/16 SAE FLAT WASHER
13	1	690877	PRESSURE WASHER MT WLD, STS 03
14	1	690879	PRESSURE WASHER SHIELD, STS 03
15	1	690732	PRESSURE WASHER WAND MT WLD
16	1	690791	HOSE, PRESSURE WASHER 690672
17	1	690673	TRIGGER GUN ASSY FOR 690672
18	2	920001	5/16 SAE FLAT WASHER

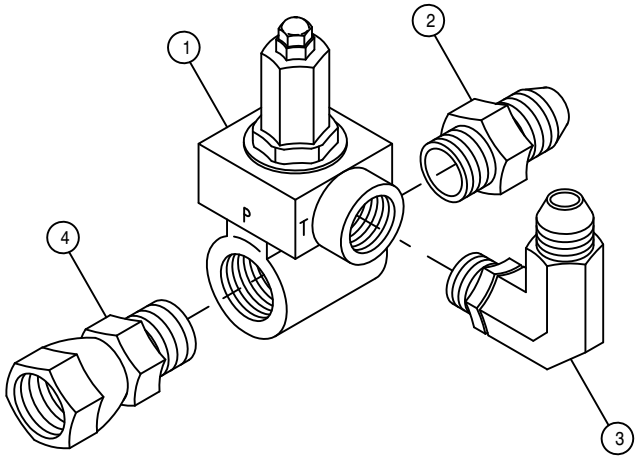

IN-LINE HYD RELIEF VALVE ASSEMBLY

DET.	QTY	PART NO.	DESCRIPTION
	1	607550	IN-LINE RELIEF VALVE, 2600 PSI
	1	611127	1 1/16MJIC-1 1/16MOR ADPTR
	1	618279	1 1/16MJIC-90-7/8MOR LBO
	1	618578	1 1/16FJIC SWIV-1 1/16MOR

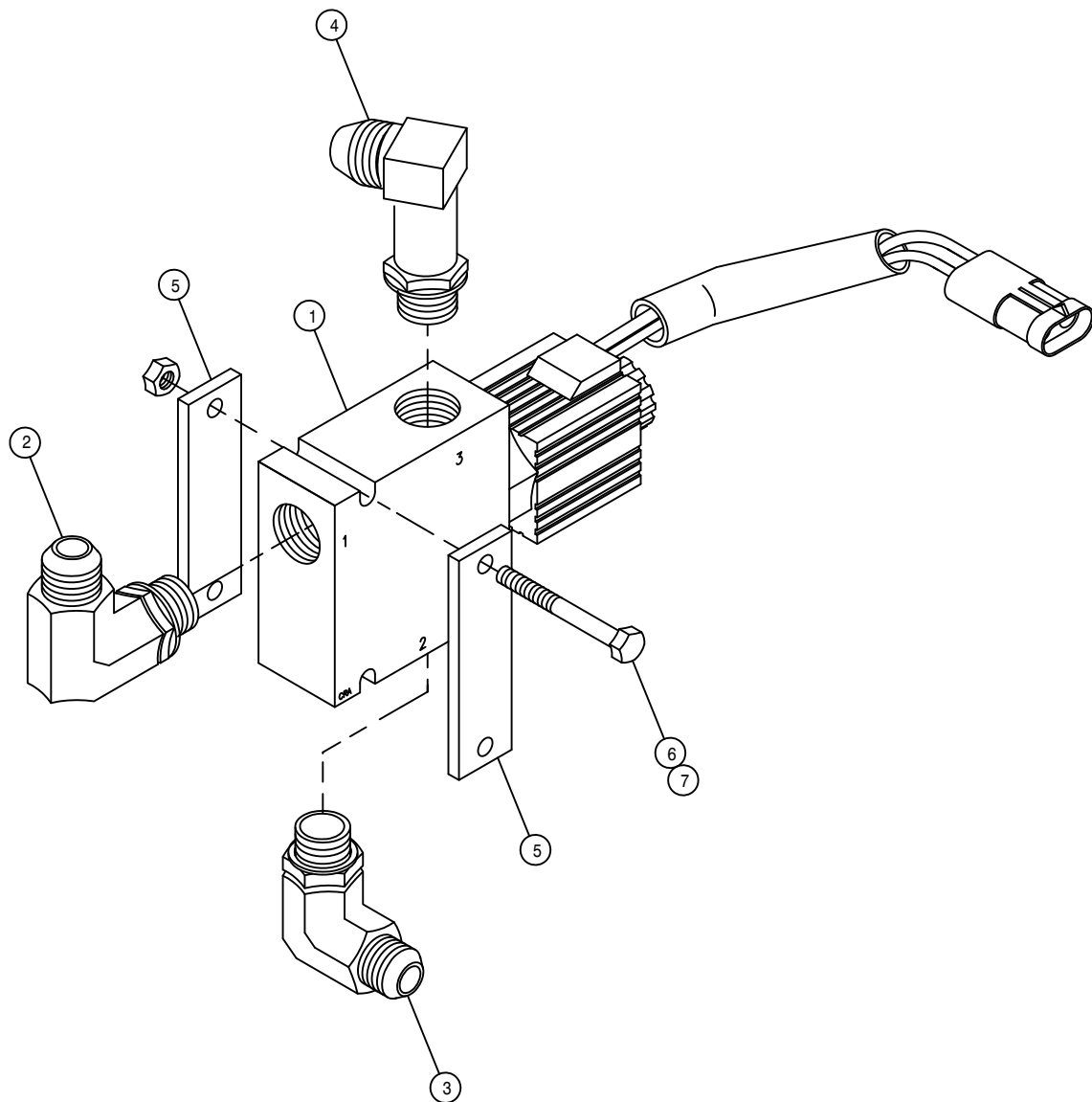

PRESSURE WASHER HYDRAULIC VALVE ASSEMBLY

DET. QTY PART NO. DESCRIPTION

1	1	606015	SIDE-FILL/WASH VLV W/SHRD ASSY
2	1	618248	1 1/16MJIC-90-1 1/16MOR LBO
3	1	618474	3/4MJIC-90-1 1/16MOR LBO
4	1	618674	1 1/16MJIC-90-1 1/16MOR XL LBO
5	2	690728	VALVE KEEPER/SPACER
6	2	900072	5/16UNC X 3" HEX BOLT
7	2	914002	5/16UNC HEX STOVER NUT

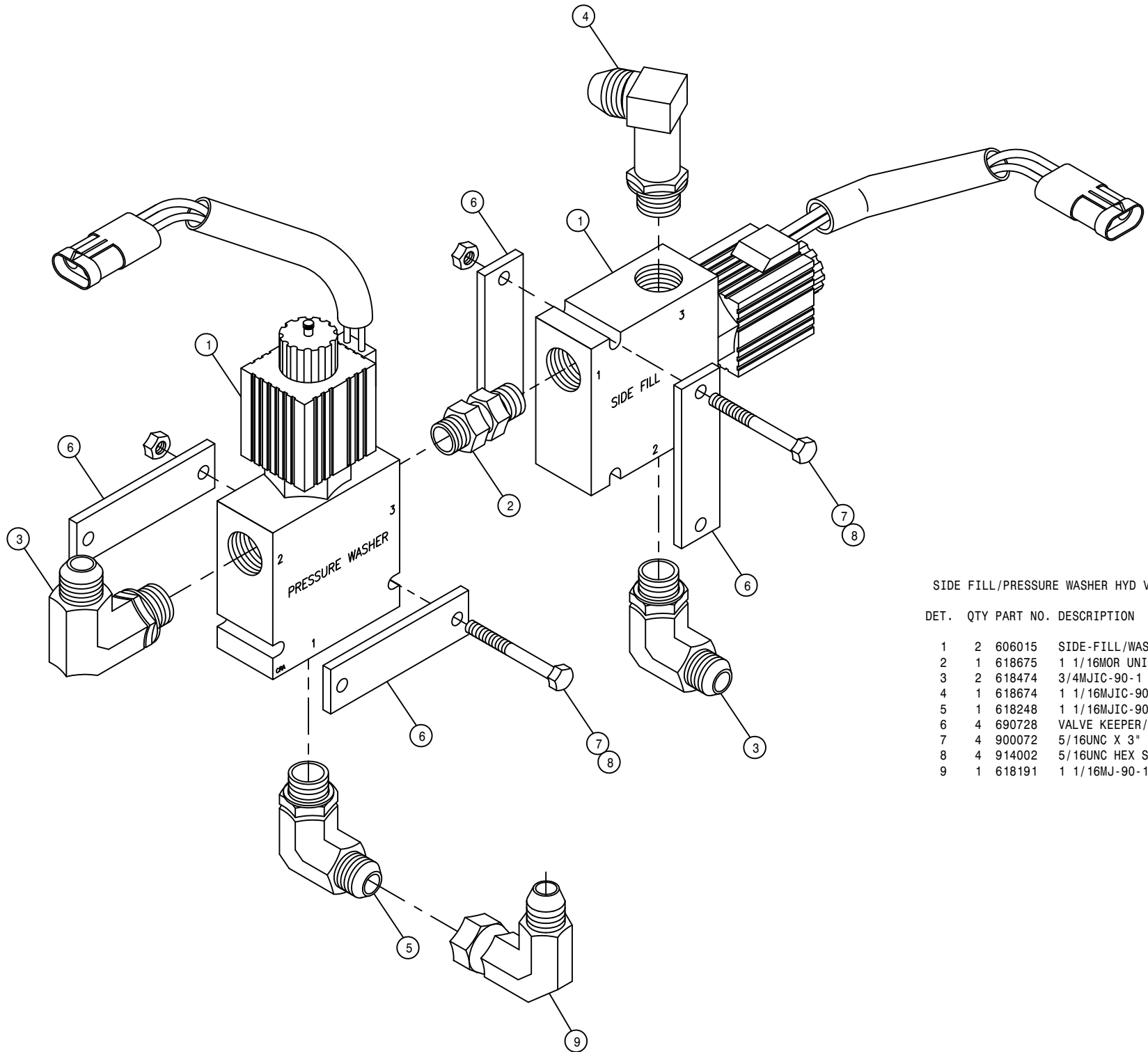

SIDE FILL/PRESSURE WASHER HYD VALVE ASSEMBLY

DET.	QTY	PART NO.	DESCRIPTION
1	2	606015	SIDE-FILL/WASH VLV W/SHRD ASSY
2	1	618675	1 1/16MOR UNION
3	2	618474	3/4MJIC-90-1 1/16MOR LBO
4	1	618674	1 1/16MJIC-90-1 1/16MOR XL LBO
5	1	618248	1 1/16MJIC-90-1 1/16MOR LBO
6	4	690728	VALVE KEEPER/SPACER
7	4	900072	5/16UNC X 3" HEX BOLT
8	4	914002	5/16UNC HEX STOVER NUT
9	1	618191	1 1/16MJ-90-1 1/16FJ SWIV LBO

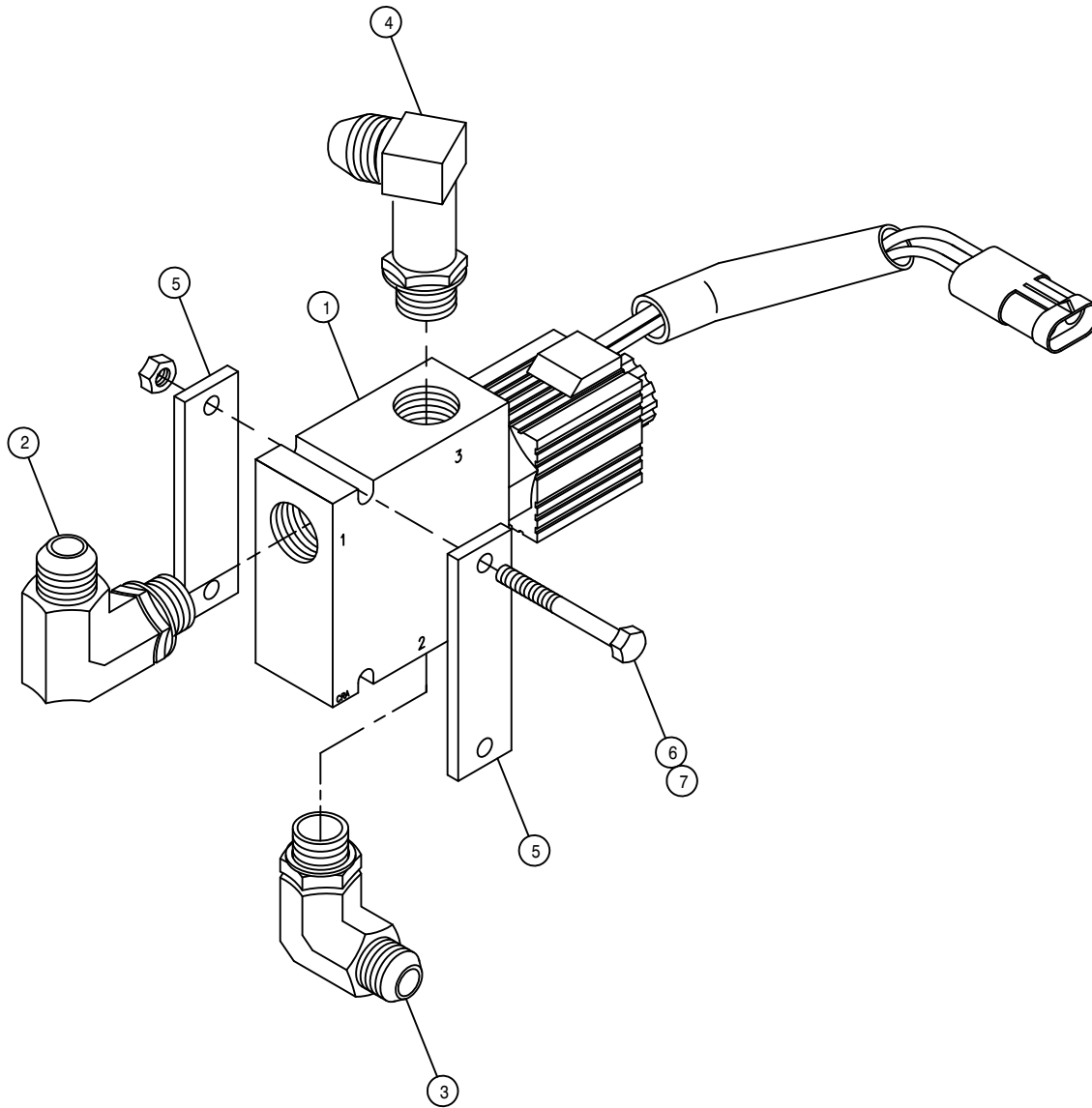

SIDE FILL HYDRAULIC VALVE ASSEMBLY

DET.	QTY	PART NO.	DESCRIPTION
1	1	606015	SIDE-FILL/WASH VLV W/SHRD ASSY
2	1	618248	1 1/16MJIC-90-1 1/16MOR LBO
3	1	618474	3/4MJIC-90-1 1/16MOR LBO
4	1	618674	1 1/16MJIC-90-1 1/16MOR XL LBO
5	2	690728	VALVE KEEPER/SPACER
6	2	900072	5/16UNC X 3" HEX BOLT
7	2	914002	5/16UNC HEX STOVER NUT

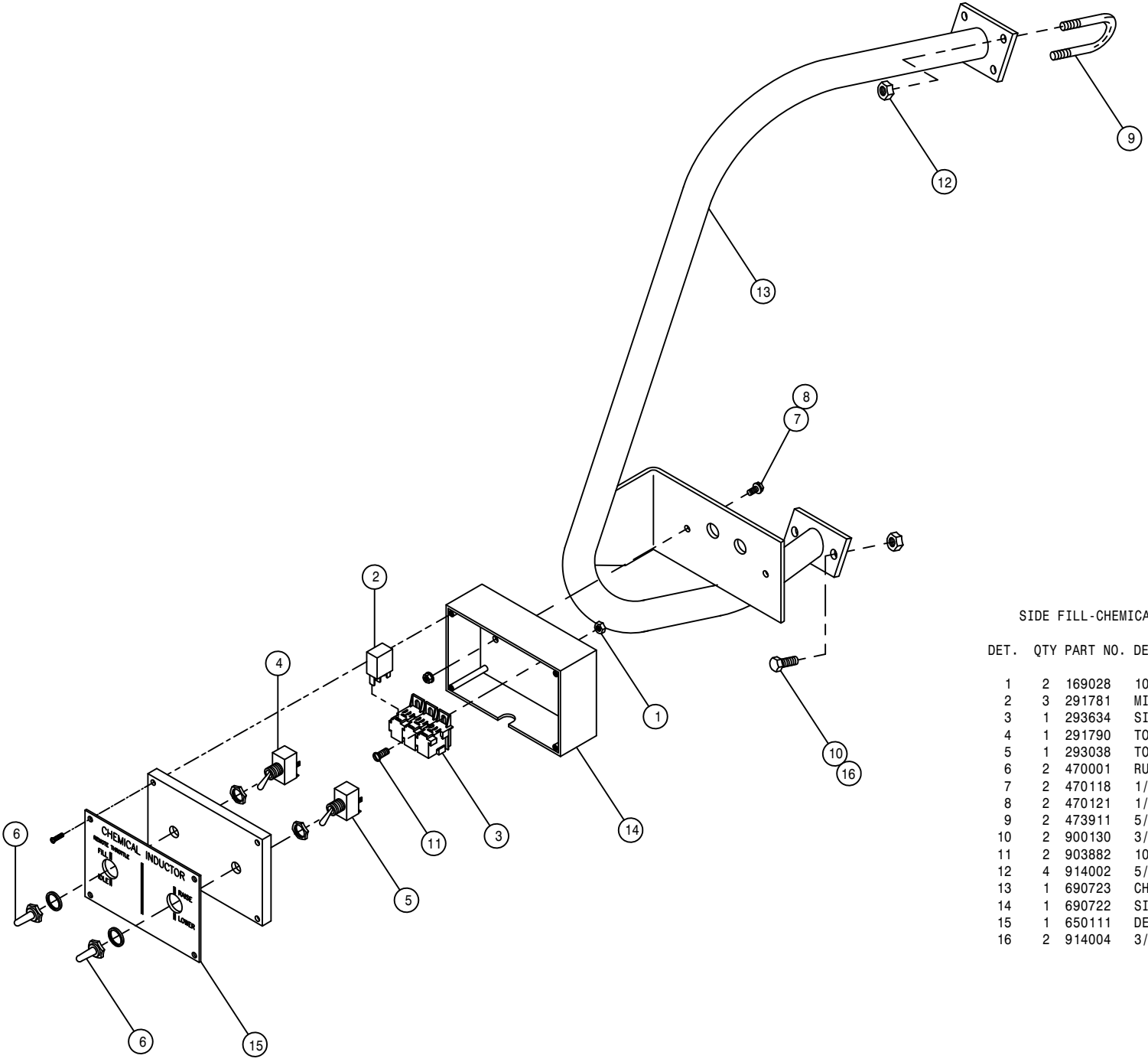

SIDE FILL-CHEMICAL INDUCTOR ASSEMBLY

DET.	QTY	PART NO.	DESCRIPTION
1	2	169028	10-24 HEX FLANGE LOCK NUT
2	3	291781	MICRO RELAY, BOSCH 12V SPDT
3	1	293634	SIDE FILL BOX HARNESS
4	1	291790	TOGGLE SWITCH, ON-OFF DPDT
5	1	293038	TOGGLE SWITCH DPDT 15 AMP
6	2	470001	RUBBER BOOT W NUT FOR 298012
7	2	470118	1/4UNC X 3/4 FLANGE HEX BOLT
8	2	470121	1/4UNC HEX FLANGE LOCK NUT
9	2	473911	5/16UNC-1.31ID-2.00 U-BOLT
10	2	900130	3/8UNC X 1 1/4 HEX BOLT
11	2	903882	10-24 X 1/2 SLT RDHD MACH SCR
12	4	914002	5/16UNC HEX STOVER NUT
13	1	690723	CHEM IND GUARD WLD
14	1	690722	SIDE FILL SWITCH BOX
15	1	650111	DECAL,CHEM INDUCTOR CTRL.STS12
16	2	914004	3/8UNC HEX STOVER NUT

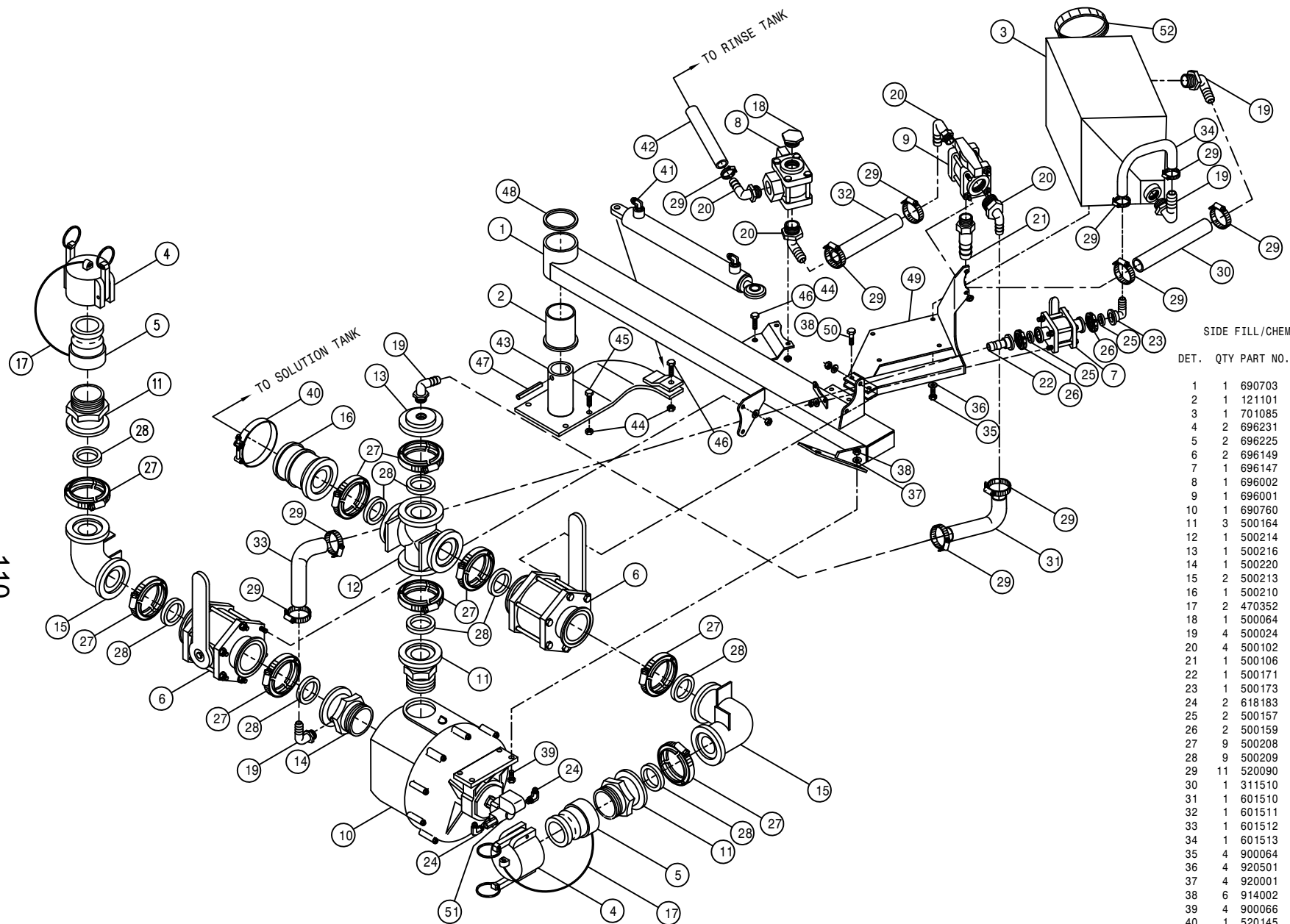

SIDE FILL/CHEMICAL INDUCTOR ASSEMBLY

DET.	QTY	PART NO.	DESCRIPTION	
1	1	690703	SIDE FILL ARM WLD	2000
2	1	121101	TRANSOM PIVOT BRG, TOP	ORKOT
3	1	701085	TANK, 5 GAL, SQ WHITE	
4	2	696231	CAP FOR 3.00 MALE COUPLER	POLY
5	2	696225	3.00FNPT-MALE COUPLER	POLY
6	2	696149	BALL VLV, 3" FLANGE	
7	1	696147	BALL VLV, 1" FLANGE	
8	1	696002	BALL VLV, 1.25NP 3WAY-SIDE	POLY
9	1	696001	BALL VLV, 1.25NP 3WAY-BOTT	
10	1	690760	BANJO PUMP, 3" SIDE FILL	STS12
11	3	500164	3" FLANGE-3" MNPT ADPTR	POLY
12	1	500214	3"FP FLANGE CROSS	
13	1	500216	3"FLANGE PLUG W/1"FNPT	POLY
14	1	500220	3"FLANGE-3"MNPT W/1"FNPT	POLY
15	2	500213	3"FLANGE-90-3"FLANGE LBO	POLY
16	1	500210	3" FLANGE-3" HOSE BARB	POLY
17	2	470352	LANYARD, 11" POLY	
18	1	500064	1 1/4"NPT PIPE PLUG, POLY	
19	4	500024	1"NPT-90-1"HOSE BARB, POLY	
20	4	500102	1 1/4NPT-90-1" HOSE BARB	POLY
21	1	500106	1 1/4NPT-1" HOSE BARB	POLY
22	1	500171	1" FLANGE-1" HOSE BARB	POLY
23	1	500173	1" FLANGE-90-1" HOSE BARB	POLY
24	2	618183	3/4MJIC-90-7/8MOR LBO	
25	2	500157	1" FLANGE GASKET	EPDM
26	2	500159	1" FLANGE CLAMP, S.S.	
27	9	500208	3" FLANGE CLAMP, S.S.	
28	9	500209	3" FLANGE GASKET	EPDM
29	11	520090	HOSE CLAMP NO 16	STAINLESS
30	1	311510	1.00 'L' HOSE, CHEM IND TANK	
31	1	601510	HOSE, 1 X 26 1BR BLK EPDM	
32	1	601511	HOSE, 1 X 38 1BR BLK EPDM	
33	1	601512	HOSE, 1 X 8 2F-1W EPDM	
34	1	601513	HOSE, 1 X 13 2F-1W EPDM	
35	4	900064	5/16UNC X 3/4 HEX BOLT	
36	4	920501	5/16 LOCK WASHER	
37	4	920001	5/16 SAE FLAT WASHER	
38	6	914002	5/16UNC HEX STOVER NUT	
39	4	900066	5/16UNC X 1 1/4 HEX BOLT	
40	1	520145	356 T-BOLT HOSE CLAMP	SS
41	1	621065	LADDER, SIDE FILL CYL ASSYSTS03	
42	1	601459	HOSE, 1 X 245 1BR BLK EPDM	
43	1	690717	CHEM IND CYL MT WLD	
44	6	914008	1/2UNC HEX STOVER NUT	
45	4	900265	1/2UNC X 1 1/2 HEX BOLT	
46	2	900267	1/2UNC X 2" HEX BOLT	
47	1	473978	ROLL PIN, 1/2 X 3 1/2 LG	
48	1	690729	3.50 OD X 2.68 ID X 11 GA WASH	
49	1	690773	CHEM IND TANK MT WLD	2001
50	2	900067	5/16UNC X 1 1/2 HEX BOLT	
51	1	690767	HYD MTR, BANJO PMP 3"POLY690760	
52	1	701155	8" LID FOR 5 GAL TANK 701085	

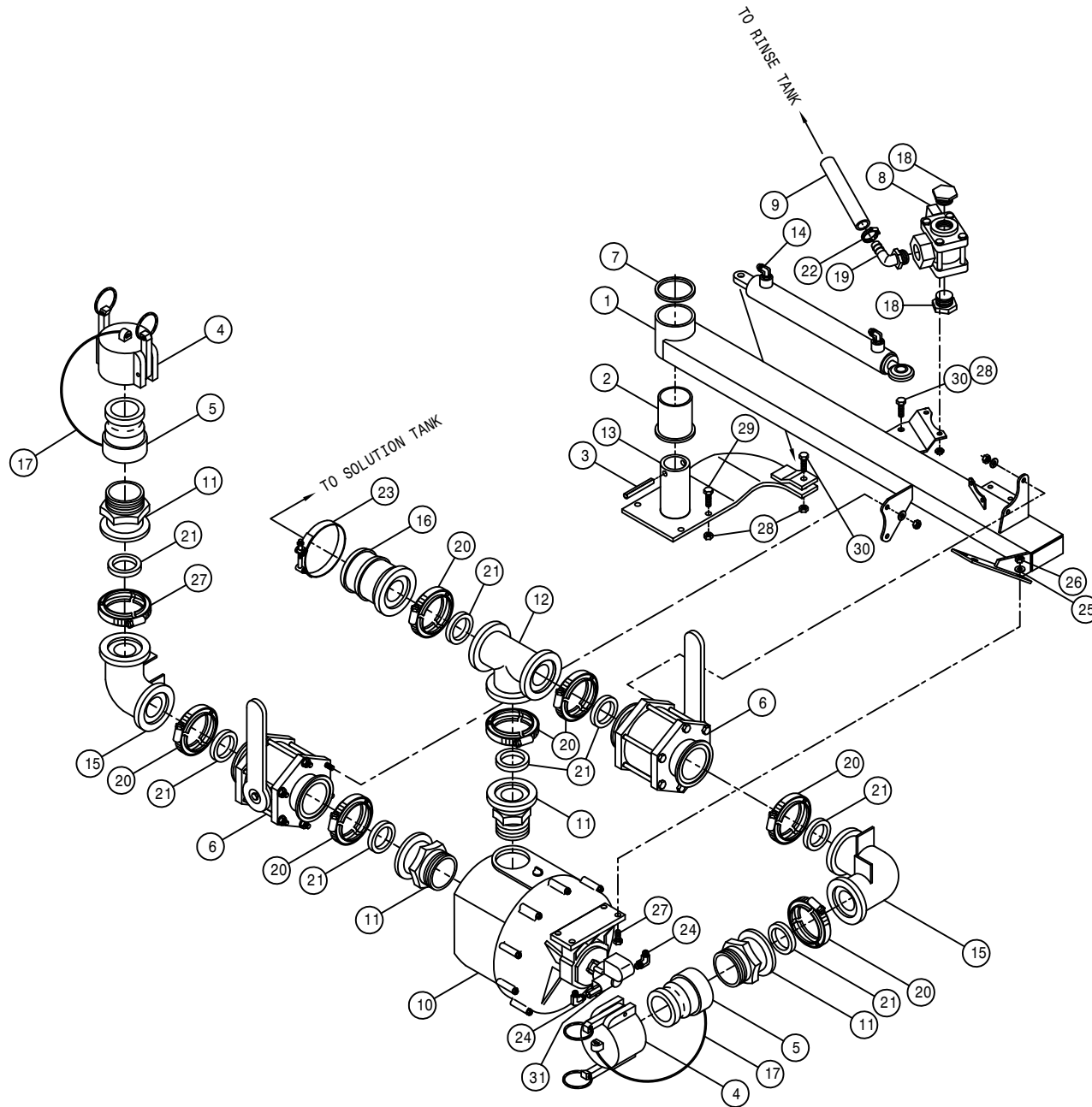

SIDE FILL ASSEMBLY

DET. QTY PART NO. DESCRIPTION

1	1	690703	SIDE FILL ARM WLD	2000
2	1	121101	TRANSOM PIVOT BRG, TOP	ORKOT
3	1	473978	ROLL PIN, 1/2 X 3 1/2 LG	
4	2	696231	CAP FOR 3.00 MALE COUPLER	POLY
5	2	696225	3.00FNPT-MALE COUPLER	POLY
6	2	696149	BALL VLV, 3" FLANGE	
7	1	690729	3.50 OD X 2.68 ID X 11 GA	WASH
8	1	696002	BALL VLV, 1.25NP 3WAY-SIDE	POLY
9	1	601459	HOSE, 1 X 245 1BR BLK	EDPM
10	1	690760	BANJO PUMP, 3" SIDE FILL	STS12
11	4	500164	3" FLANGE-3" MNPT ADPTR	POLY
12	1	500217	3" FLANGE TEE	POLY
13	1	690717	CHEM IND CYL MT WLD	
14	1	621065	LADDER, SIDE FILL CYL	ASSYSTS03
15	2	500213	3" FLANGE-90-3" FLANGE	LBO POLY
16	1	500210	3" FLANGE-3" HOSE BARB	POLY
17	2	470352	LANYARD, 11"	POLY
18	2	500064	1 1/4" NPT PIPE PLUG, POLY	
19	1	500102	1 1/4" NPT-90-1" HOSE BARB	POLY
20	8	500208	3" FLANGE CLAMP, S.S.	
21	8	500209	3" FLANGE GASKET	EPDM
22	1	520090	HOSE CLAMP NO 16	STAINLESS
23	1	520145	356 T-BOLT HOSE CLAMP	SS
24	2	618183	3/4MJIC-90-7/8MOR	LBO
25	4	920001	5/16 SAE FLAT WASHER	
26	4	914002	5/16UNC HEX STOVER NUT	
27	4	900066	5/16UNC X 1 1/4 HEX BOLT	
28	6	914008	1/2UNC HEX STOVER NUT	
29	4	900265	1/2UNC X 1 1/2 HEX BOLT	
30	2	900267	1/2UNC X 2" HEX BOLT	
31	1	690767	HYD MTR, BANJO PMP 3" POLY	690760

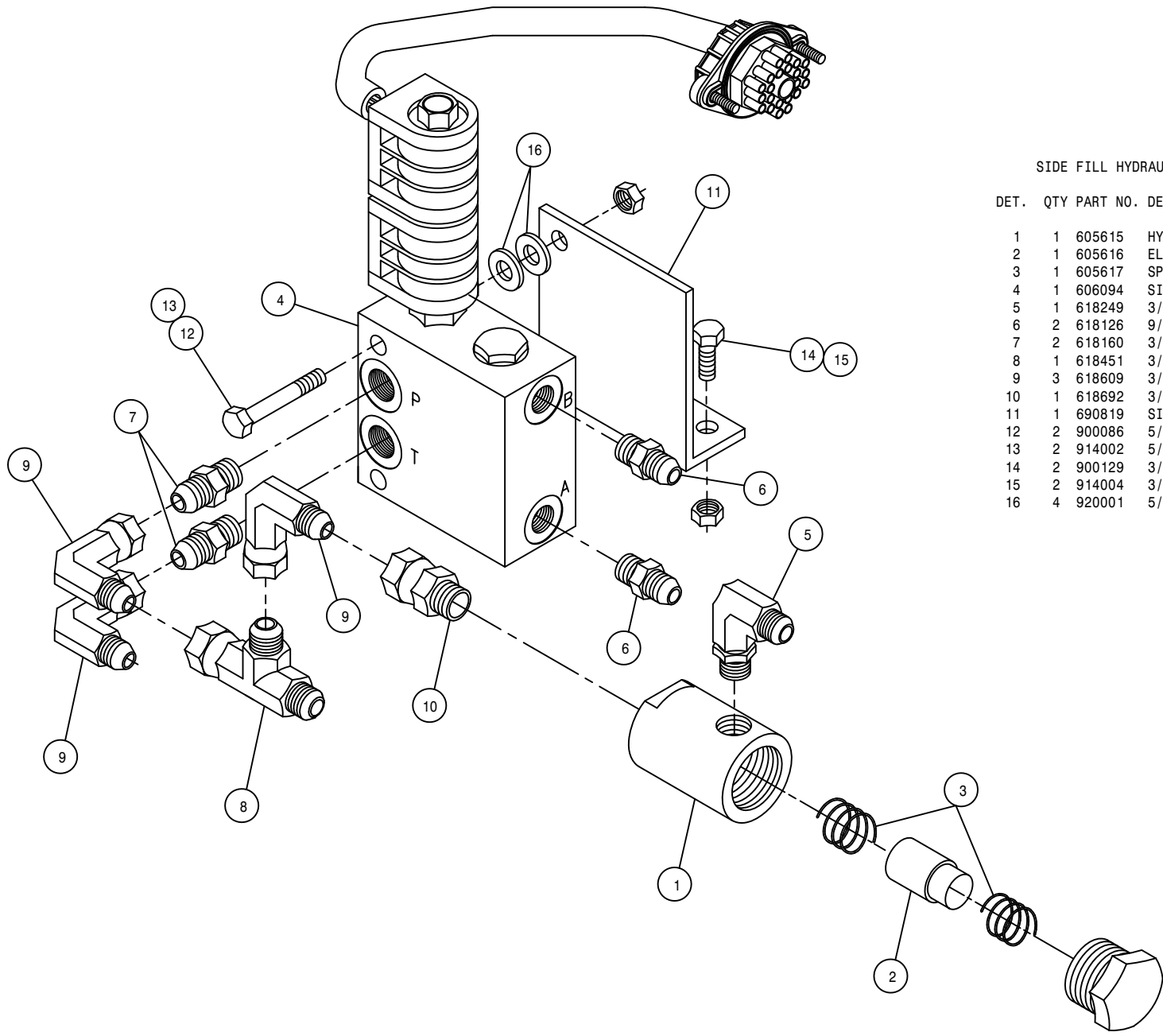

SIDE FILL HYDRAULIC VALVE ASSEMBLY

DET.	QTY	PART NO.	DESCRIPTION
1	1	605615	HYD FILTER, INLINE 25M 9/16FOR
2	1	605616	ELEMENT, 25M HYD FILTER 605615
3	1	605617	SPRING KIT, HYD FILTER 605615
4	1	606094	SIDEFILL VLV, W/LEADS DELTA
5	1	618249	3/4MJIC-90-9/16MOR LBO
6	2	618126	9/16MJIC-9/16MOR ADPTR
7	2	618160	3/4MJIC-7/16MOR ADPTR
8	1	618451	3/4FJIC SW RUN TEE-3/4MJIC
9	3	618609	3/4MJIC-90-3/4FJIC SWIV LBO
10	1	618692	3/4FJIC SWIV-9/16MOR ADPTR
11	1	690819	SIDEFILL HYD VLV MT, STS10 02
12	2	900086	5/16UNC X 2 1/4 HEX BOLT
13	2	914002	5/16UNC HEX STOVER NUT
14	2	900129	3/8UNC X 1" HEX BOLT
15	2	914004	3/8UNC HEX STOVER NUT
16	4	920001	5/16 SAE FLAT WASHER

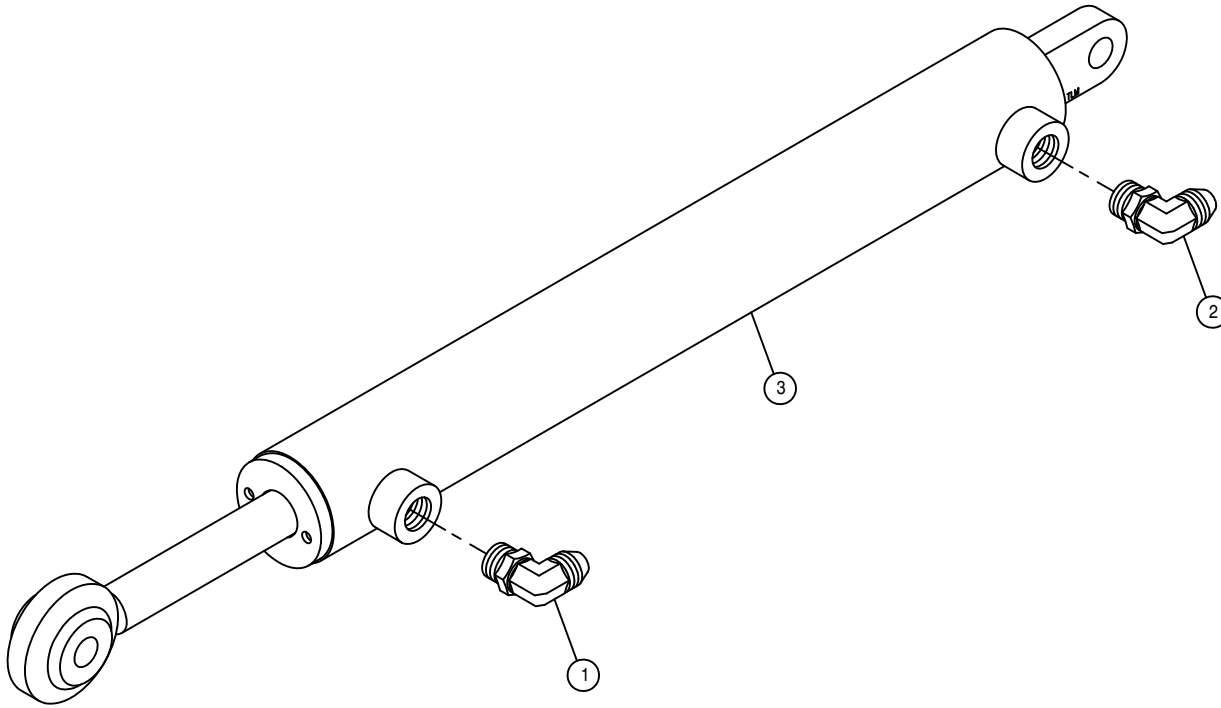

LADDER AND SIDE FILL CYLINDER ASSEMBLY

DET. QTY PART NO. DESCRIPTION

1	1	614750	.042 ELBOW ASSY,9/16MOR 90D
2	1	618119	9/16MJIC-90-9/16MOR LBO
3	1	621554	LADR/SF/BRKWAY CYL,1.50 X12.25
NS	1	621555	REPAIR KIT,HYD CYL 621554

NOTE: 621065 - LADDER & SIDE FILL CYLINDER ASSEMBLY WITH FITTINGS

FRONT FILL ASSEMBLY

DET. QTY PART NO. DESCRIPTION

1	1	470352	LANYARD, 11" POLY
2	1	500063	1"NPT PIPE PLUG, POLY
3	1	500074	1"NPT-1" HOSE BARB, POLY
4	1	500164	3" FLANGE-3" MNPT ADPTR POLY
5	2	500208	3" FLANGE CLAMP, S.S.
6	2	500209	3" FLANGE GASKET EPDM
7	1	500210	3" FLANGE-3" HOSE BARB POLY
8	1	695900	BALL VALVE 1IN FNPT POLY
9	1	696149	BALL VLV, 3" FLANGE
10	1	696225	3.00FNPT-MALE COUPLER POLY
11	1	696231	CAP FOR 3.00 MALE COUPLER POLY
12	1	470253	HYD DAMPER, 100LB,4.0 STROKE
13	2	470254	BALL SOCKET, M6 THD X 10MM
14	2	470255	BALL STUD,5/16-18 THD X 10MM
15	2	470256	SAFTY CLIP, 10MM BALL SOCKET
16	2	920501	5/16 LOCK WASHER
17	2	910002	5/16UNC HEX NUT
18	1	690690	FRT FILL SUPP ARM WLD
19	1	690698	FRT FILL SUPP ARM REL WLD
20	1	690701	FRT FILL SUPP ARM LATCH PIN
21	1	472316	ROLL PIN, 5/16 X 1 1/2
22	1	482017	SPRING
23	1	900066	5/16UNC X 1 1/4 HEX BOLT
24	1	914002	5/16UNC HEX STOVER NUT
25	1	920006	3/4 SAE FLAT WASHER
26	1	900418	3/4UNC X 7" HEX BOLT
27	1	914012	3/4UNC HEX STOVER NUT
28	1	601497	HOSE, 1 X 200 1BR BLK EPDM
29	1	601575	HOSE, 3 X 160 POLY HELIX EPDM
30	1	520145	356 T-BOLT HOSE CLAMP SS
31	1	520090	HOSE CLAMP NO 16 STAINLESS
32	1	785007	KNOB,1 3/16" BALL,RED,3/8-16

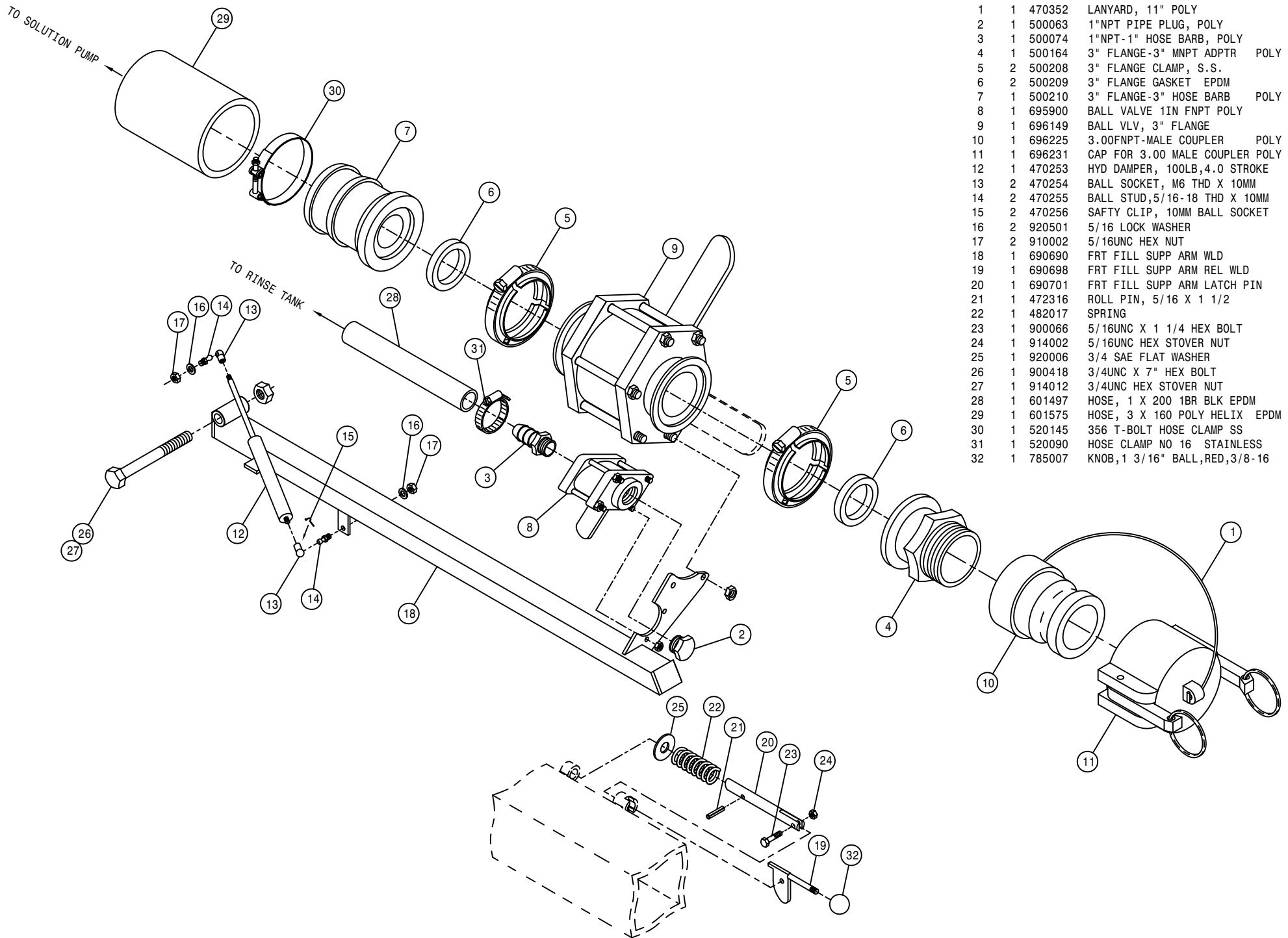

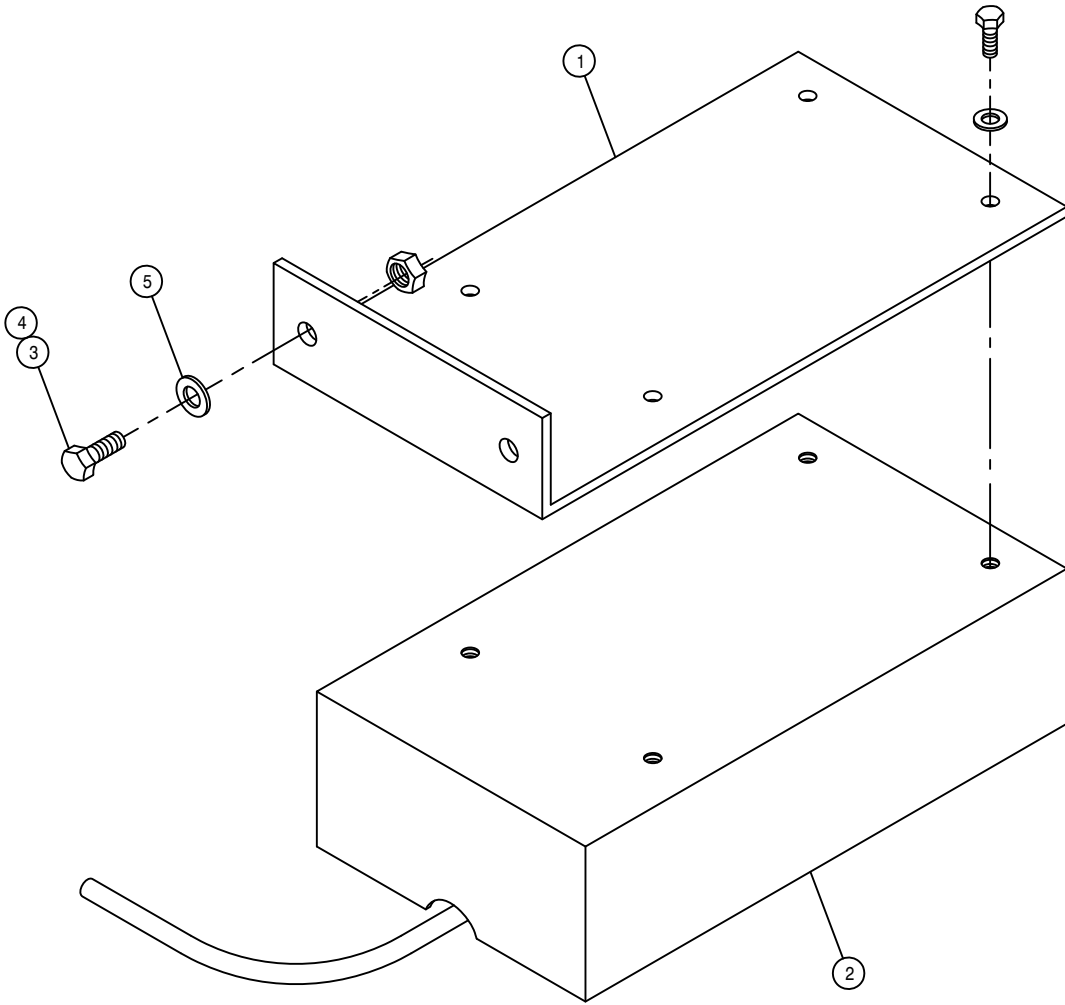

RADAR OPTION

DET. QTY PART NO. DESCRIPTION

1	1	342857	RADAR MTG BRKT
2	1	690599	RAVEN RADAR UNIT W/CABLE
3	2	900129	3/8UNC X 1" HEX BOLT
4	2	914004	3/8UNC HEX STOVER NUT
5	2	920002	3/8 SAE FLAT WASHER

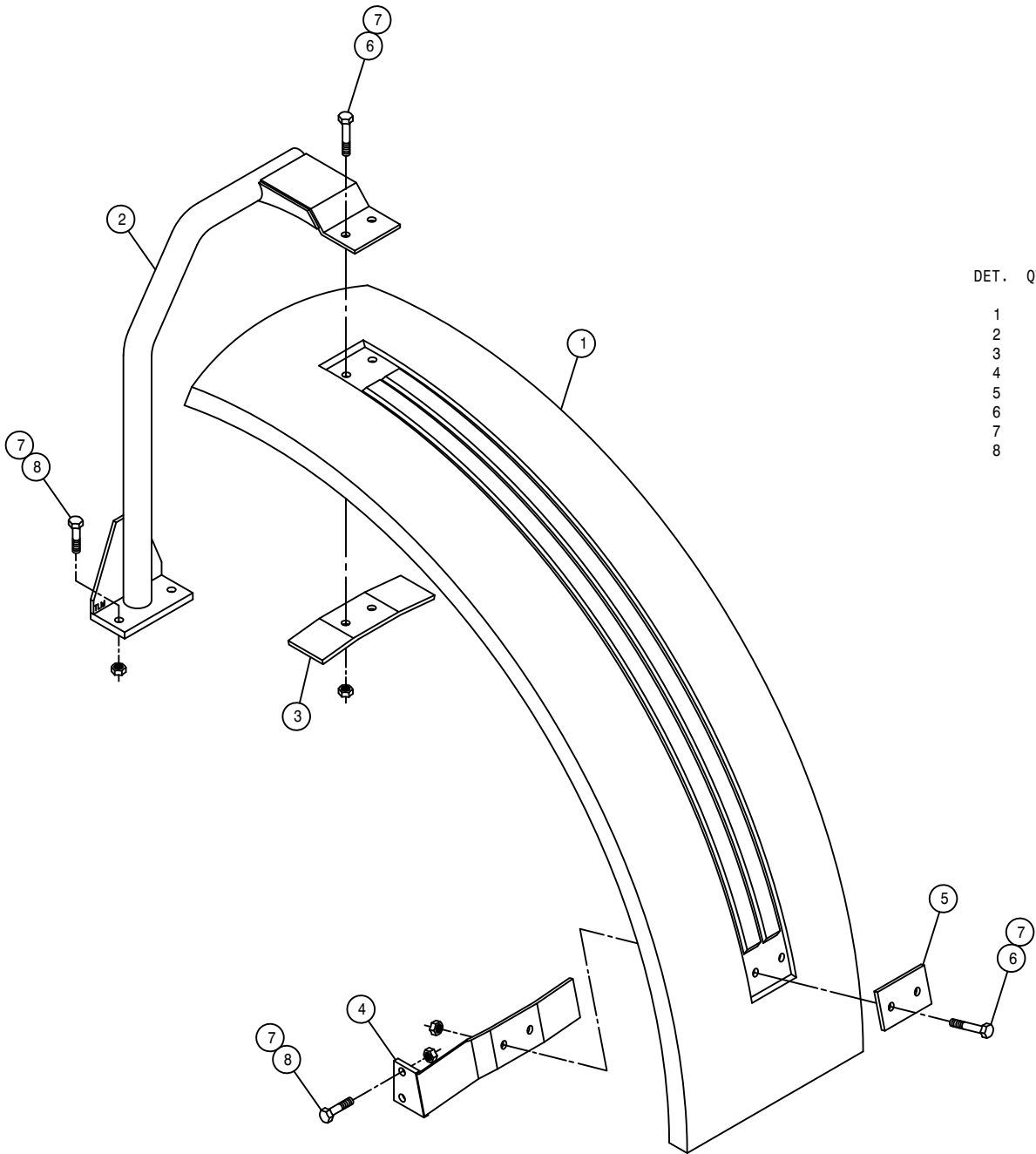

RIGHT FENDER ASSEMBLY

DET.	QTY	PART NO.	DESCRIPTION	
1	1	359151	FENDER, STS12	2000
2	1	359205	RH FENDER MT WLD STS	03
3	1	359160	FENDER MT KEEPER	STS12
4	1	359208	RH FENDER SUPP BRKT WLD STS	03
5	1	359167	FENDER SUPPORT KEEPER	STS12
6	4	900268	1/2UNC X 2 1/2 HEX BOLT	
7	8	914008	1/2UNC HEX STOVER NUT	
8	4	900266	1/2UNC X 1 3/4 HEX BOLT	

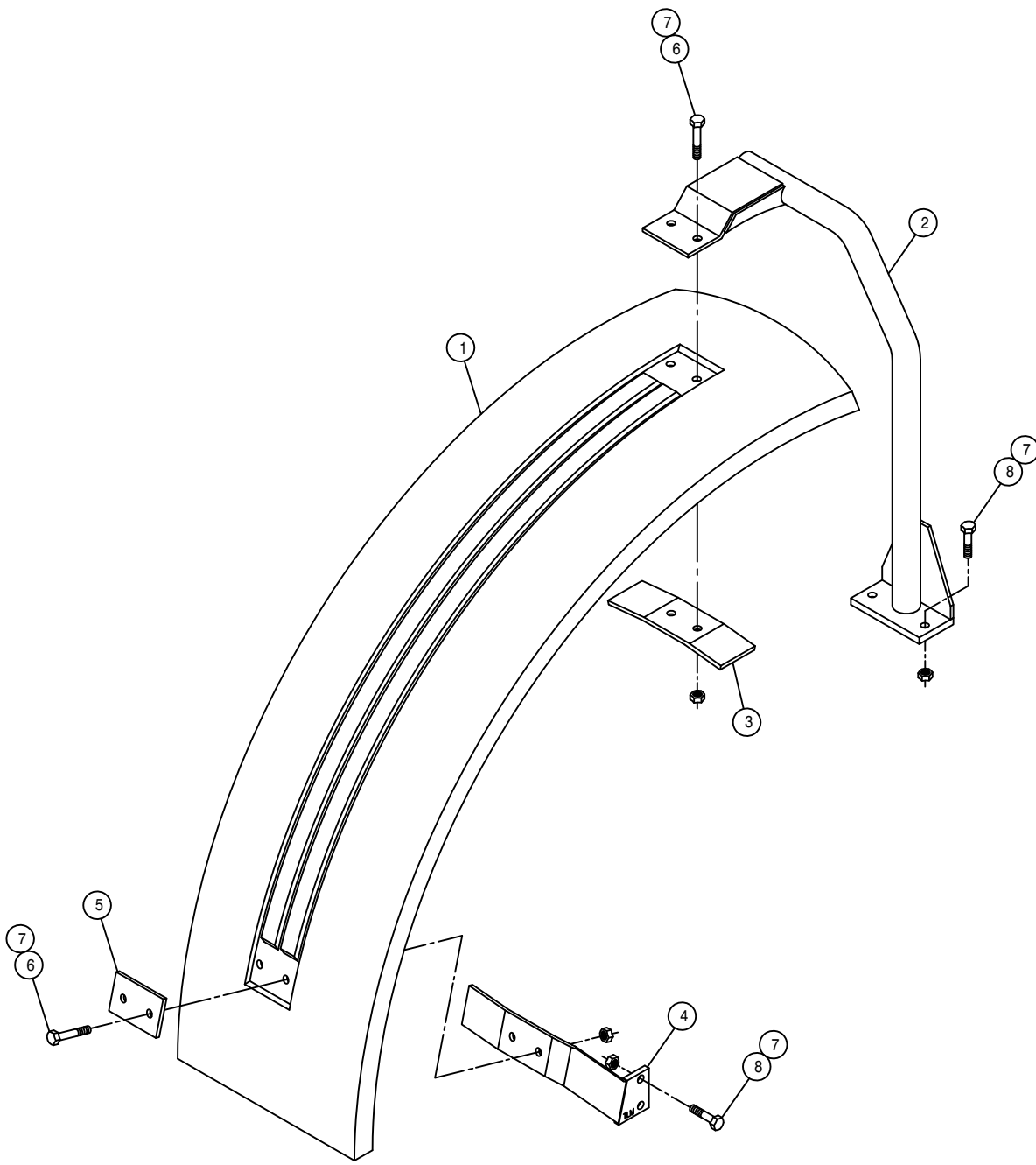

LEFT FENDER ASSEMBLY

DET.	QTY	PART NO.	DESCRIPTION	
1	1	359151	FENDER, STS12	2000
2	1	359206	LH FENDER MT WLD STS12	03
3	1	359160	FENDER MT KEEPER	STS12
4	1	359209	LH FENDER SUPP BRKT WLD STS 03	
5	1	359167	FENDER SUPPORT KEEPER	STS12
6	4	900268	1/2UNC X 2 1/2 HEX BOLT	
7	8	914008	1/2UNC HEX STOVER NUT	
8	4	900266	1/2UNC X 1 3/4 HEX BOLT	

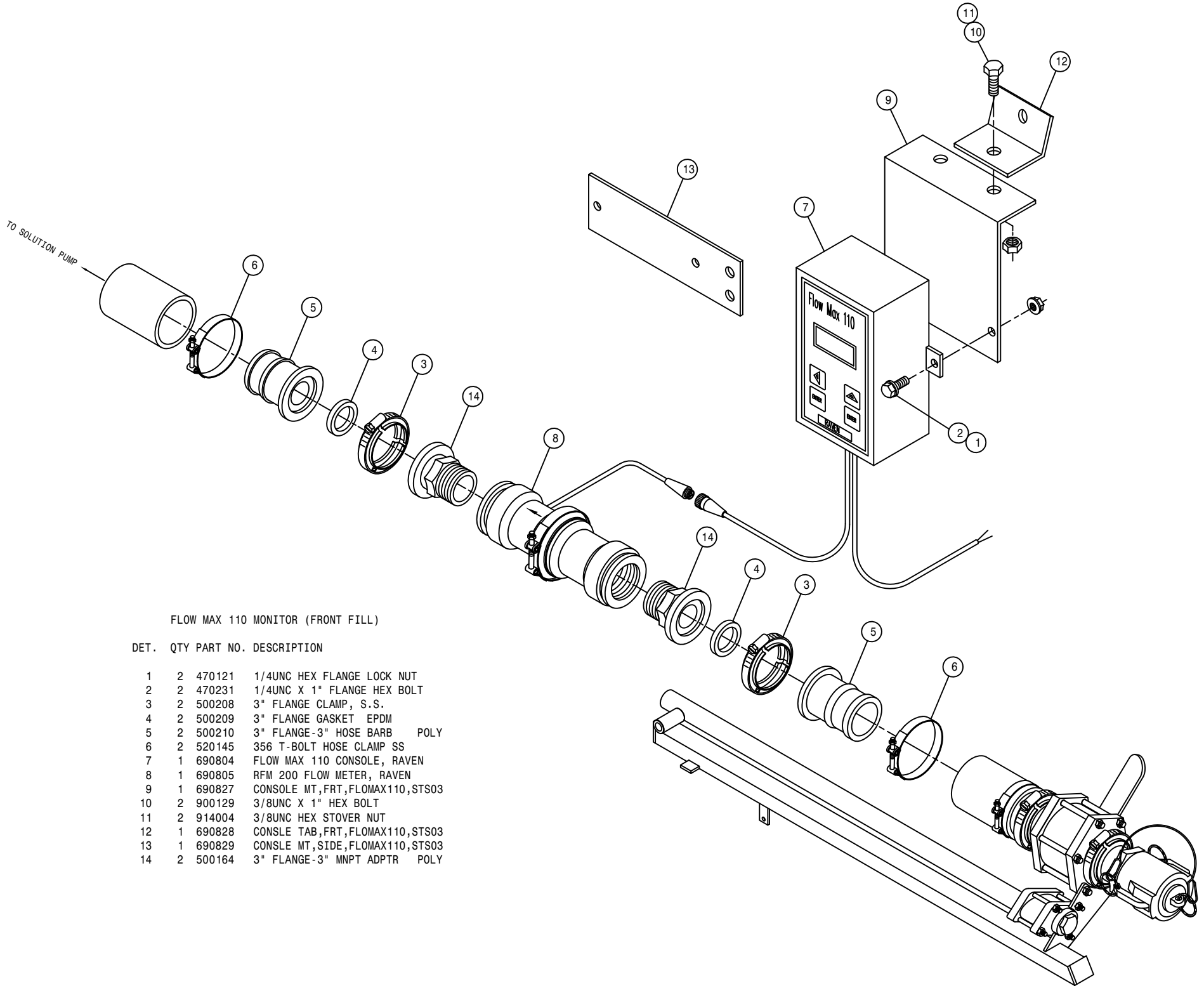

FLOW MAX 110 MONITOR (FRONT FILL)

DET.	QTY	PART NO.	DESCRIPTION
1	2	470121	1/4UNC HEX FLANGE LOCK NUT
2	2	470231	1/4UNC X 1" FLANGE HEX BOLT
3	2	500208	3" FLANGE CLAMP, S.S.
4	2	500209	3" FLANGE GASKET EPDM
5	2	500210	3" FLANGE-3" HOSE BARB POLY
6	2	520145	356 T-BOLT HOSE CLAMP SS
7	1	690804	FLOW MAX 110 CONSOLE, RAVEN
8	1	690805	RFM 200 FLOW METER, RAVEN
9	1	690827	CONSOLE MT, FRT, FLOMAX110, STS03
10	2	900129	3/8UNC X 1" HEX BOLT
11	2	914004	3/8UNC HEX STOVER NUT
12	1	690828	CONSOLE TAB, FRT, FLOMAX110, STS03
13	1	690829	CONSOLE MT, SIDE, FLOMAX110, STS03
14	2	500164	3" FLANGE-3" MNPT ADPTR POLY

This Page Intentionally Blank

NOTICE

The following page contains decals for the model STS 10.

These decals can be obtained from Hagie Mfg. Co. and should be used whenever your machine is repainted or when the decals become worn, weathered, or faded.

Special attention should be paid to decals involving personal safety. They have been attached for your protection.

KEEP THEM IN PLACE.

**Contact: Hagie Manufacturing Co.
Box 273
Clarion, Iowa 50525**

STS10 DECALS

<u>QTY.</u>	<u>PART NO.</u>	<u>DESCRIPTION</u>	<u>LOCATION</u>
1	650101	BOOM SPRAY VALVE SWITCH DECAL	ON THE SOLUTION SWITCH BOX
1	650102	HYDROSTATIC CONTROL PANEL DECAL	ON HYDRO LEVER MOUNT
4	650103	TREAD ADJUST INDICATOR DECAL	1-ON EACH LEG SLIDE TUBE
1	650105	SOLUTION TANK DECAL SET	ON SOLUTION TANK
1	650107	CAUTION BOOSTER DECAL	NEAR BOOSTER POSTS
1	650108	MAIN SPRAY POWER DECAL	ON ATI CONTROL BOX
1	650109	LOW HYDRAULIC OIL DECAL	ON ATI CONTROL BOX
1	650110	PRESSURE WASHER DECAL	ON PRESSURE WASHER SWITCH BOX
1	650111	CHEMICAL INDUCTOR CONTROL DECAL	ON CHEM INDUCTOR CONTROL BOX
1	650112	HAGIE UPFRONT STRG WHEEL DECAL	ON STEERING WHEEL
1	650113	EMERGENCY EXIT DECAL	ON RH SIDE WINDOW HANDLE
1	650114	FILL WITH FRESH WATER DECAL	ON FRESH WATER TANK
1	650115	HAND WASH ONLY DECAL	NEAR HAND WASH VALVE
1	650116	INDUCTOR FILL INSTRUCTION DECAL	ON SIDE OF FILL ARM
1	650117	LATCH RELEASE DECAL	1-REAR RAD GRILLE DOOR
1	650118	DO NOT USE EITHER DECAL	NEAR AIR INTAKE ON SHEET METAL
1	650120	LATCH RELEASE W/ARROW DECAL	1-ENGINE SIDE DOOR
1	650122	POLY SOLUTION TANK DECAL	ON SOLUTION TANK
1	650124	RINSE CONTROL PANEL DECAL	ON THE SWITCH PANEL
1	650125	AGITATOR RATE IND DECAL	ON KZCO AGITATION VALVE
1	650121	ENGINE COMPARTMENT DECAL SET	ON ENGINE SHEET METAL
1	650337	ELECTROCUTION HAZARD DECAL	ON RH SIDE WINDOW
2	650339	WARNING, HYD OIL INJ DECAL	1-ON SIDE OF OIL TANK 1-NEAR ELECTIC VALVE ON TRANSOM
1	650340	CAUTION, PARKING BRAKE DECAL	ON RH SIDE WINDOW
1	650347	NOTICE-R134 DECAL	RH SIDE OF ENGINE ON FRAME
1	650348	DRAIN TANK DECAL SET	ON AIR TANK
1	650363	FRONT RECEPTACLE PANEL DECAL	ON RECEPTACLE PANEL
1	650365	LADDER DO NOT STEP DECAL	ON TOP OF LADDER PIVOT TUBE
1	650367	AIR FILTER INSTRUCTION DECAL	ON ENGINE AIR FILTER END CAP
1	650848	CAUTION, SLIP OR FALL DECAL	ON LADDER PIVOT TUBE
1	650849	CAUTION, ENGINE FUEL DECAL	NEAR FUEL TANK NECK
1	650850	DANGEROUS CHEM DECAL	SOLUTION TANK FILLER NECK
1	650851	SHIELDS DECAL	ON LOWER LH REAR MAINFRAME TUBE
1	650852	READ MANUAL DECAL	ON LEFT SIDE WINDOW
1	650954	DIESEL DECAL	NEAR FUEL TANK NECK
1	650981	COOLING SYSTEM DECAL	NEAR RADIATOR CAP
1	650982	ELECTRICAL DECAL	ON RH CAB DOOR
4	650985	WHEEL BOLT TORQUE DECAL	ON EACH WHEEL RIM

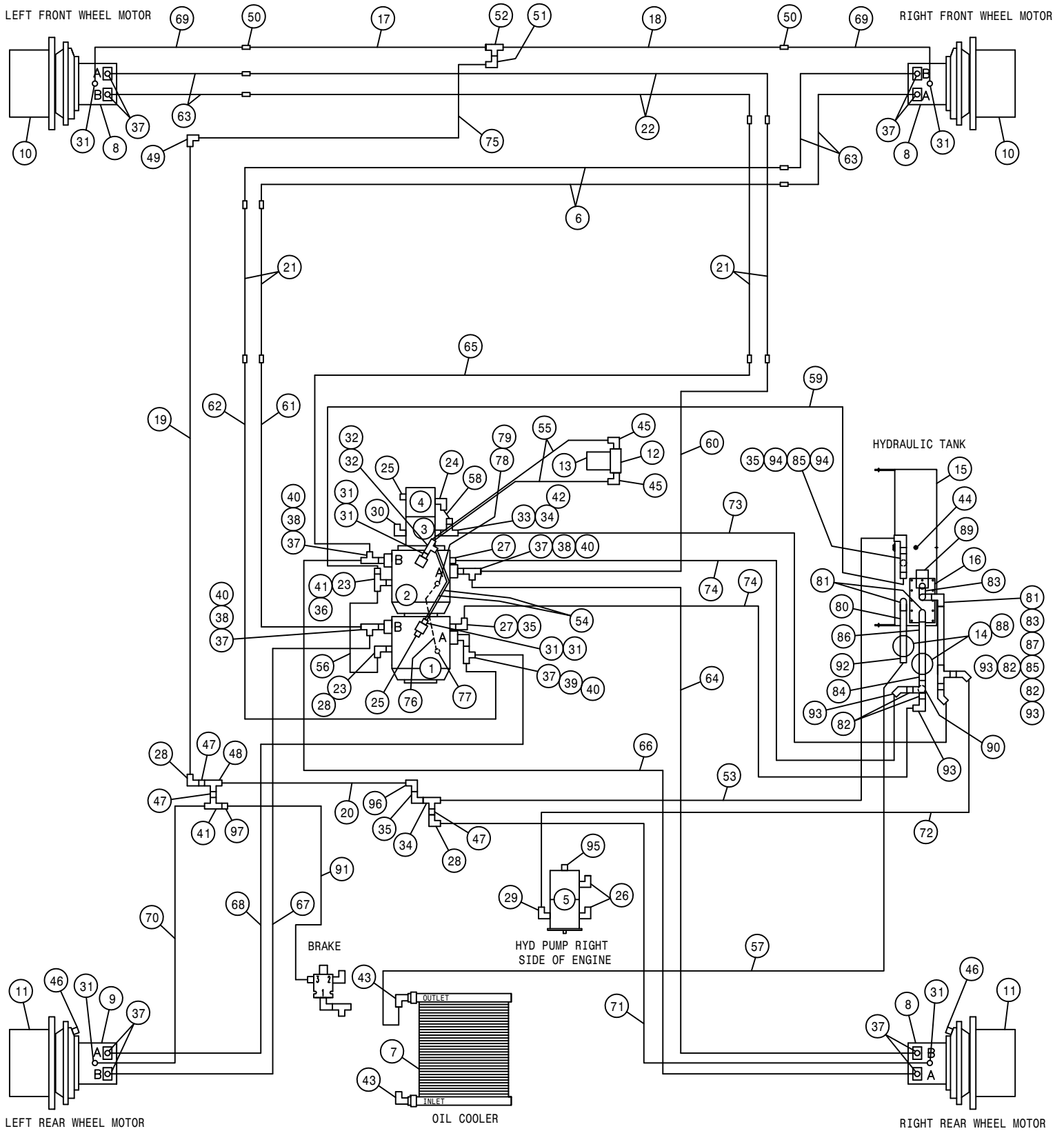

STS10 HYDRAULIC SCHEMATIC 2003
REFERENCE DRAWING NO. 498724S1

DET.	QTY	PART NO.	DESCRIPTION	DET.	QTY	PART NO.	DESCRIPTION
1	1	606966	SUND 75CC PUMP,C/C-MT	50	2	618456	7/8MJIC UNION
2	1	606969	SUND 75CC PUMP,C/B-MT	51	1	618301	7/8MJIC-90-7/8FJIC SWIV LBO
3	1	606984	SUND GEAR PUMP,2.02CI GRP3	52	1	618581	7/8MJIC UNION TEE
4	1	606987	SUND GEAR PUMP,.128CI GRP3	53	1	616127	16-421HT-16FJX-16FJX90-73 H/A
5	1	606990	TANDEM PUMP,.66CI/.51CI	54	2	616099	08-451TC-08FJX-08FJX-16 H/A
6	2	615784	RH FRT WHL MAIN HYD TUBE ASSY	55	2	616100	08-451TC-08FJX-08FJX-19 H/A
7	1	618800	OIL COOLER STS12 2000	56	1	616107	08-451TC-12FJX-12FJX-17 H/A
8	3	606978	SUND HYD MOTOR	57	1	616116	16-421HT-16FJX-20FJX-154 H/A
9	1	606993	SAUER HYD MOTOR W/DIV-2 SENSOR	58	1	616117	06-451TC-06FJX-06FJX-17 H/A
10	2	610711	TORQ HUB, 22:1 CW12	59	1	616126	16-421HT-16FJX-16FJX-73 H/A
11	2	610714	TORQ HUB, 27:1 CW12	60	1	616061	16C15-16FFOX-16FFOX-30 H/A
12	1	605608	HYD FILTER HEAD, DONALDSON	61	1	616062	16C15-16FFOX-16FFOX-58 H/A
13	1	605609	HYD FILTER ELEMENT, DONALDSON	62	1	616063	16C15-16FFOX-16FFOX90-81 H/A
14	2	605611	FILTER HEAD, 1 1/2FNPTF ZINGA	63	4	616064	16C15-16FFOX-16FLG-132 H/A
15	1	760231	HYD TANK WLD STS12	64	1	616065	16C15-16FFOX-16FLG-165 H/A
16	1	760239	RECEIVER PLATE WLD STS12	65	1	616066	16C15-16FFOX90-16FFOX90-38 H/A
17	1	615775	LH FRT CASEDRAIN HYD TUBE ASSY	66	1	616067	16C15-16FFOX90-16FLG-193 H/A
18	1	615776	RH FRT CASEDRAIN HYD TUBE ASSY	67	1	616068	16C15-16FFOX90-16FLG-203 H/A
19	1	615778	FRT CASE DRAIN HYD TUBE ASSY	68	1	616069	16C15-16FFOX90-16FLG-223 H/A
20	1	615779	CASE DRAIN HYD TUBE ASSY	69	2	616103	08-451TC-08FJX-10FJX-136 H/A
21	4	615785	FRT WHL MAIN HYD TUBE ASSY	70	1	616104	08-451TC-08FJX-12FJX-160 H/A
22	2	615783	LH FRT WHL MAIN HYD TUBE ASSY	71	1	616106	08-451TC-08FJX-12FJX-175 H/A
23	2	611127	1 1/16MJIC-1 1/16MOR ADPTR	72	1	616110	16-451TC-12FJX-16FJX-84 H/A
24	1	618115	9/16MJIC-90-3/4MOR LBO	73	1	616111	16-451TC-16FJX-16FJX-32 H/A
25	2	618126	9/16MJIC-9/16MOR ADPTR	74	2	616112	16-451TC-16FJX-16FJX-42 H/A
26	2	618183	3/4MJIC-90-7/8MOR LBO	75	1	616113	10-421HT-10FJX-12FJX-55 H/A
27	2	618186	1 5/16MJIC-1 5/16MOR ADPTR	76	1	616038	04C2AT-06FJX-06FJX90-15 H/A
28	3	618191	1 1/16MJ-90-1 1/16FJ SWIV LBO	77	1	614754	.050 ELBOW ASSY,9/16MOR 90D
29	1	618248	1 1/16MJIC-90-1 1/16MOR LBO	78	1	618444	9/16MOR RUN TEE-9/16MJIC
30	1	618302	1 1/16MJIC-90-1 5/16MOR LBO	79	1	618531	9/16FJIC CAP NUT
31	8	618327	3/4MJIC-7/8MOR ADPTR	80	1	507009	BLK PIPE NIPPLE 1.50NPT-6.00
32	2	618451	3/4FJIC SW RUN TEE-3/4MJIC	81	3	507014	BLK PIPE EL 90DEG 1.50NPT
33	1	618455	1 5/16MJIC-1 5/8MOR ADPTR	82	4	507015	RED BUSH 1.50NPT - 1.25FNPT
34	2	618619	1 5/16FJ SW RUN TEE-1 5/16MJ	83	2	507018	BLK PIPE ST EL 90DEG 1.50NPT
35	3	618640	1 5/16MJ-90-1 5/16FJ SWIV LBO	84	1	507019	CLOSE NIPPLE 1.50NPT
36	1	618641	1 1/16FJIC-1 5/16MJIC ADPTR	85	2	507250	BLK PIPE TEE 1.50NPT
37	12	618652	1" SPLIT FLANGE KIT	86	1	507610	BLK PIPE NIPPLE 1.50NPT-8.00
38	3	618653	1" FLANGE-1 7/16MFOR ADPTR	87	1	507617	BLK PIPE NIPPLE 1.50NPT-16.00
39	1	618654	1" FLANGE-90-1 7/16MFOR LBO	88	2	605612	FILTER, 10 MICRON ZINGA
40	4	618655	1 7/16FFOX RUN TEE-1 7/16MFOR	89	1	605613	TANK FILTER,100 MESH,1 1/2FNPT
41	2	618660	1 1/16FJX BRANCH TEE-1 1/16MJ	90	1	507252	SIDE OUTLET EL 90DEG 1.50NPT
42	1	618661	1 5/16FJIC-9/16MJIC ADPTR	91	1	616083	04-451TC-06FJX-06FJX-36 H/A
43	2	618463	1 5/16MJIC-90-1 5/16MOR XL LBO	92	1	618656	1 5/8MJIC-1 1/2MNPT ADPTR
44	1	470308	1/2MNPT DRAIN PLUG,AL HD,MAG	93	4	618667	1 5/16MJIC-45-1 1/4MNPT LBO
45	2	618474	3/4MJIC-90-1 1/16MOR LBO	94	2	618672	1 5/16MJIC-1 1/2MNPT ADPTR
46	2	618666	7/16MJIC-M12X1.5MOR ADPTR	95	1	618315	3/4MJIC-45-3/4MOR LBO
47	3	618541	1 5/16FJIC-1 1/16MJIC ADPTR	96	1	618441	1 5/16MJIC-90-1 5/16MJIC LBO
48	1	618658	1 5/16MJIC UNION TEE	97	1	618483	1 1/16FJIC-9/16MJIC ADPTR
49	1	618448	1 1/16MJIC-90-1 1/16MJIC LBO				

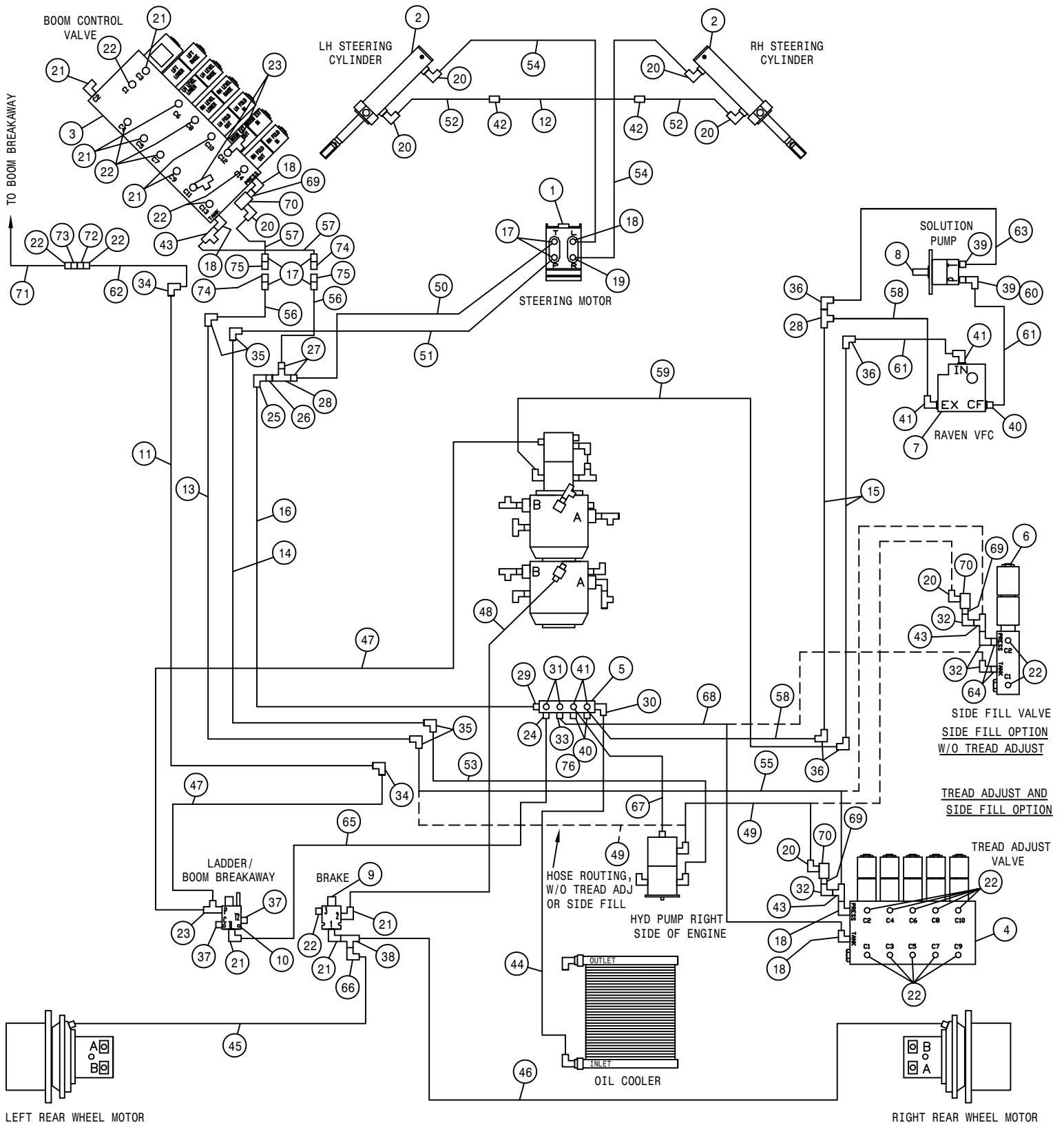

STS10 HYDRAULIC SCHEMATIC 2003
REFERENCE DRAWING NO. 498724S2

DET.	QTY	PART NO.	DESCRIPTION	DET.	QTY	PART NO.	DESCRIPTION
1	1	749321	STEERING CONTROL MTR 14.1CI	39	2	618273	1 1/16MJIC-1/2MNPT ADPTR
2	2	621550	STEERING CYL, 2.50 X 8.81 STS	40	3	611127	1 1/16MJIC-1 1/16MOR ADPTR
3	1	606104	BOOM CTRL VLV, STS PWRSYS 03	41	4	618248	1 1/16MJIC-90-1 1/16MOR LBO
4	1	606103	TREAD ADJ VLV, STS PWRSYS 03	42	2	618314	3/4MJIC UNION
5	1	606029	RETURN MANIFOLD BLOCK, STS 03	43	3	618451	3/4FJIC SW RUN TEE-3/4MJIC
6	1	606094	SIDEFILL VLV, W/LEADS DELTA	44	1	616187	16-421HT-16FJX-20FJX-103 H/A
7	1	690666	VALVE HYD CTRL, 30GPM RAVEN	45	1	616072	04-451TC-04FJX45-06FJX-195 H/A
8	1	690670	HYPRO PUMP, 9305C-HM3CB	46	1	616073	04-451TC-04FJX45-06FJX-202 H/A
9	1	606013	BRAKE VLV W/TOWER ASSY	47	2	616080	04-451TC-06FJX-06FJX-30 H/A
10	1	606011	LADDER/BRKWAY VLV W/TOWER ASSY	48	1	616081	04-451TC-06FJX-06FJX-31 H/A
11	1	615771	BRKAWAY/TRD MAIN HYD TUBE ASSY	49	1	616093	08-451TC-08FJX-08FJX-86 H/A
12	1	615772	STRG CYL JUMPER HYD TUBE ASSY	50	1	616094	06-451TC-08FJX-08FJX-31 H/A
13	1	615773	STACK VALVE MAIN HYD TUBE ASSY	51	1	616095	06-451TC-08FJX-08FJX-33 H/A
14	1	615774	STEERING MAIN HYD TUBE ASSY	52	2	616096	06-451TC-08FJX-08FJX-37 H/A
15	2	615777	SOLUTION PUMP HYD TUBE ASSY	53	1	616097	08-451TC-08FJX-08FJX-90 H/A
16	1	615782	FRT MAIN RETURN HYD TUBE ASSY	54	2	616098	06-451TC-08FJX-08FJX-94 H/A
17	6	611125	3/4MJIC-3/4MOR ADPTR	55	1	616101	08-451TC-08FJX-08FJX-31 H/A
18	5	618241	3/4MJIC-90-3/4MOR LBO	56	2	616186	08-451TC-08FJX-08FJX-62 H/A
19	1	618443	3/4MJIC-90-3/4MOR EX LG LBO	57	2	616190	08-451TC-08FJX-08FJX-72 H/A
20	7	618249	3/4MJIC-90-9/16MOR LBO	58	2	616108	10-451TC-12FJX-12FJX-28 H/A
21	9	618119	9/16MJIC-90-9/16MOR LBO	59	1	616109	10-451TC-12FJX-12FJX-32 H/A
22	21	618126	9/16MJIC-9/16MOR ADPTR	60	1	618191	1 1/16MJ-90-1 1/16FJ SWIV LBO
23	3	618444	9/16MOR RUN TEE-9/16MJIC	61	2	616188	10-451TC-12FJX90-12FJX-19 H/A
24	1	618344	9/16MJIC-1 1/16MOR ADPTR	62	1	616089	04-451TC-06FJX-06FJX-60 H/A
25	1	618657	1 5/8MJIC-90-1 5/8MJIC LBO	63	1	616189	10-451TC-12FJX90-12FJX-29 H/A
26	1	618665	1 5/8FJIC-1 1/16MJIC ADPTR	64	2	618160	3/4MJIC-7/16MOR ADPTR
27	2	618484	1 1/16FJIC-3/4MJIC ADPTR	65	1	616083	04-451TC-06FJX-06FJX-36 H/A
28	2	618487	1 1/16FJ SW RUN TEE-1 1/16MJ	66	1	618618	9/16MJIC-90-9/16FJIC SWIV LBO
29	1	618471	1 5/8MJIC-1 5/16MOR ADPTR	67	1	616136	08-451TC-08FJX-12FJX-72 H/A
30	1	618476	1 5/8MJIC-90-1 5/16MOR LBO	68	1	616139	08-451TC-08FJX-08FJX-36 H/A
31	2	610186	1 1/16MOR PLUG	69	3	618692	3/4FJIC SWIV-9/16MOR ADPTR
32	4	618609	3/4MJIC-90-3/4FJIC SWIV LBO	70	3	605615	HYD FILTER, INLINE 25M 9/16FOR
33	1	618469	3/4MJIC-1 1/16MOR ADPTR	71	1	616090	04-451TC-06FJX-06FJX-85 H/A
34	2	618603	9/16MJIC-90-9/16MJIC LBO	72	1	618694	HYD COUPLER, FEM 1/4B, 9/16FOR
35	4	618442	3/4MJIC-90-3/4MJIC LBO	73	1	618695	HYD COUPLER, MALE 1/4B, 9/16FOR
36	4	618448	1 1/16MJIC-90-1 1/16MJIC LBO	74	2	618696	HYD COUPLER, FEM 1/2B, 3/4FOR
37	2	610185	9/16MOR PLUG	75	2	618697	HYD COUPLER, MALE 1/2B, 3/4FOR
38	1	618486	9/16FJIC SW RUN TEE-9/16MJIC	76	2	618533	1 1/16FJIC CAP NUT

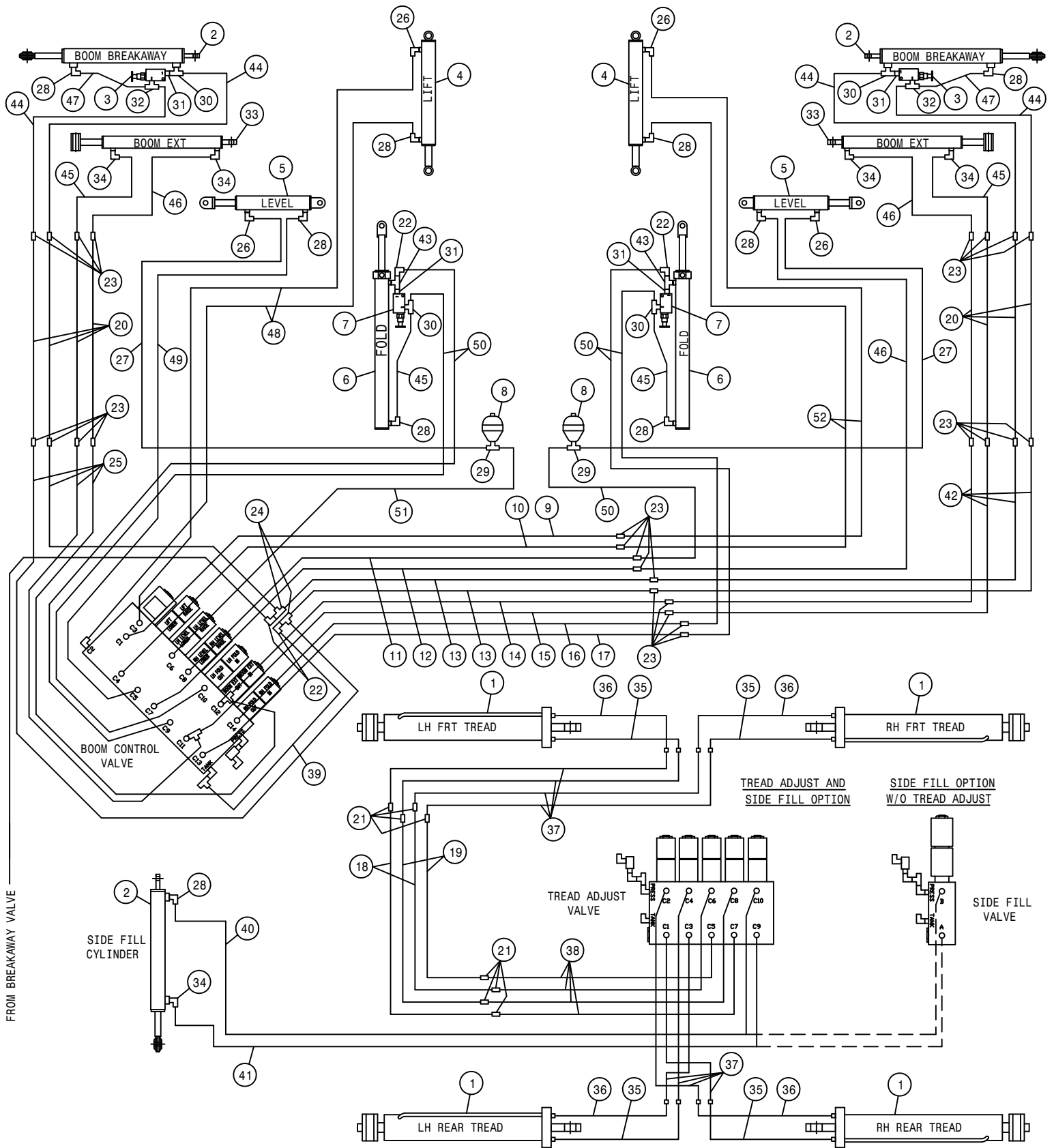

STS10 HYDRAULIC SCHEMATIC 2003
REFERENCE DRAWING NO. 498724S3

DET.	QTY	PART NO.	DESCRIPTION	DET.	QTY	PART NO.	DESCRIPTION
1	4	621552	TRD ADJ CYL, 3.00 X 16.00 STS	27	2	616128	06-451TC-06FJX-06FJX-48 H/A
2	3	621554	LADR/SF/BRKWAY CYL,1.50 X12.25	28	9	618119	9/16MJIC-90-9/16MOR LBO
3	2	607540	KICK-DOWN RELIEF VALVE, 800PSI	29	2	618673	3/4MOR BRANCH TEE-9/16MJIC
4	2	621556	LIFT CYL, 2.50 X 18.00 STS	30	4	618629	9/16MOR BRANCH TEE-9/16MJIC
5	2	621558	LEVEL CYL, 3.00 X 11.00 STS	31	4	618668	9/16FJIC SWIV-9/16MOR ADPTR
6	2	621560	FOLD CYL, 2.50 X 21.000 STS	32	2	614752	RESTRICTOR BR TEE ASSY, .042DIA
7	2	607541	KICK-DOWN RELIEF VALVE,4500PSI	33	2	621562	OUTR FOLD CYL,2.25 X 21.00 STS
8	2	470326	ACCUMULATOR, DIAPHRAGM	34	5	614750	.042 ELBOW ASSY,9/16MOR 90D
9	1	615761	LIFT RAISE HYD TUBE ASSY	35	4	616070	04-451TC-04MJBH-06MOR-11.00H/A
10	1	615762	LIFT LOWER HYD TUBE ASSY	36	4	616071	04-451TC-04MJBH-06MOR-13.00H/A
11	1	615763	LEVEL RAISE HYD TUBE ASSY	37	8	616074	04-451TC-04FJX90-06FJX-26 H/A
12	1	615764	LEVEL LOWER HYD TUBE ASSY	38	4	616079	04-451TC-06FJX-06FJX-29 H/A
13	2	615765	BREAKAWAY HYD TUBE ASSY	39	1	616124	04-451TC-06FJX-08FJX-24 H/A
14	1	615766	BOOM EXTN RAISE HYD TUBE ASSY	40	1	616118	04-451TC-06FJX-06FJX-165 H/A
15	1	615767	BOOM EXTN LOWER HYD TUBE ASSY	41	1	616119	04-451TC-06FJX-06FJX-175 H/A
16	1	615768	RH FOLD RAISE HYD TUBE ASSY	42	4	616089	04-451TC-06FJX-06FJX-60 H/A
17	1	615769	RH FOLD LOWER HYD TUBE ASSY	43	2	614756	RESTRICTOR BR TEE ASSY, .025DIA
18	2	615770	FRT TRD ADJ MAIN HYD TUBE ASSY	44	4	616090	04-451TC-06FJX-06FJX-85 H/A
19	2	615771	BRKAWAY/TRD MAIN HYD TUBE ASSY	45	4	616077	04-451TC-06FJX-06FJX-18 H/A
20	8	615760	BOOM HYD TUBE ASSY	46	3	616083	04-451TC-06FJX-06FJX-36 H/A
21	8	618603	9/16MJIC-90-9/16MJIC LBO	47	2	616075	04-451TC-06FJX-06FJX-9 H/A
22	4	618618	9/16MJIC-90-9/16FJIC SWIV LBO	48	2	616084	04-451TC-06FJX-06FJX-46 H/A
23	26	619010	9/16MJIC UNION	49	1	616085	04-451TC-06FJX-06FJX-43 H/A
24	2	618019	9/16MJIC UNION TEE	50	5	616086	04-451TC-06FJX-06FJX-45 H/A
25	4	616133	04-451TC-06FJX-06FJX-72 H/A	51	1	616087	04-451TC-06FJX-06FJX-52 H/A
26	4	618689	9/16MOR-90-9/16MJ .042 CHK VLV	52	2	616088	04-451TC-06FJX-06FJX-56 H/A

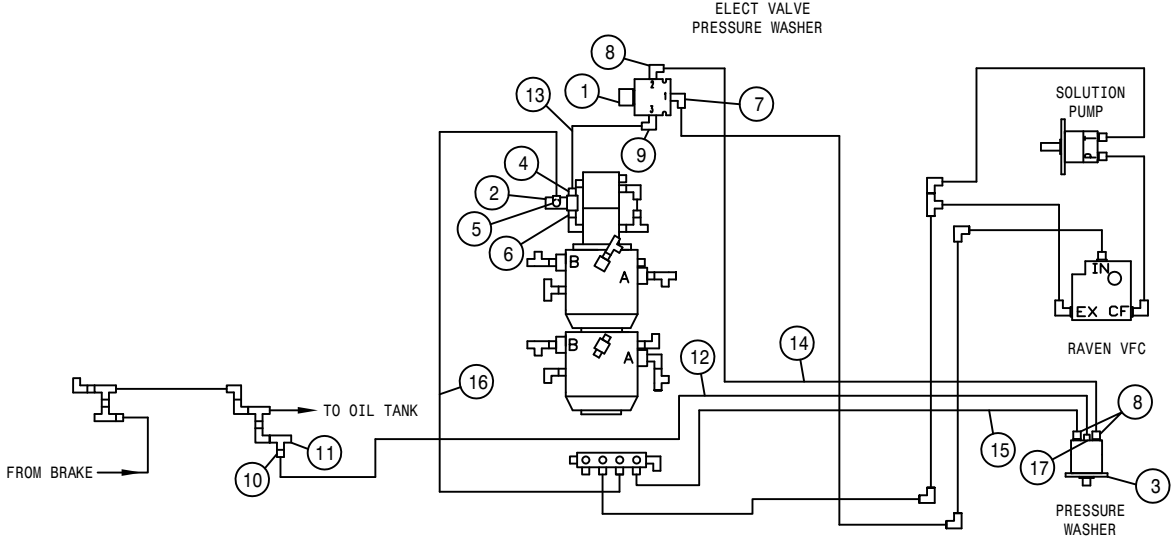
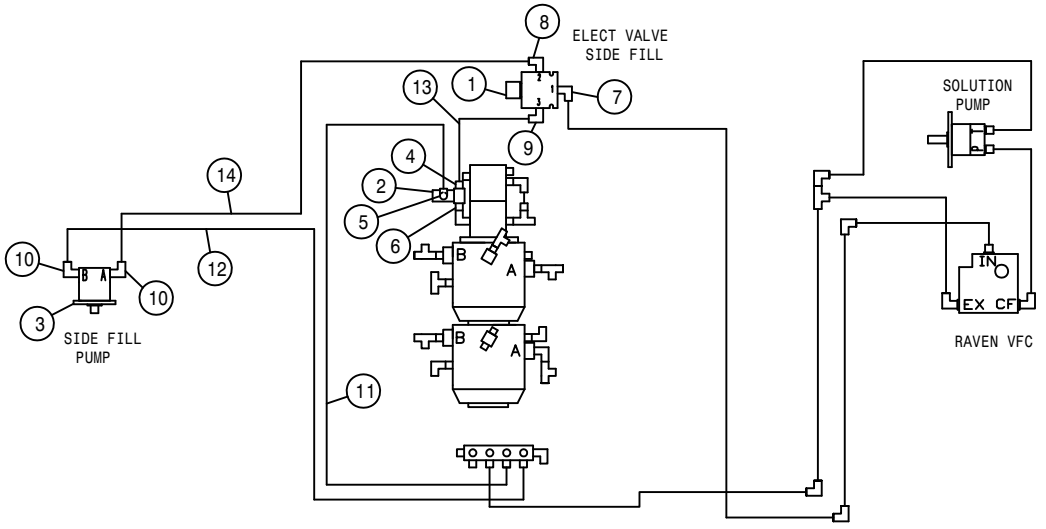
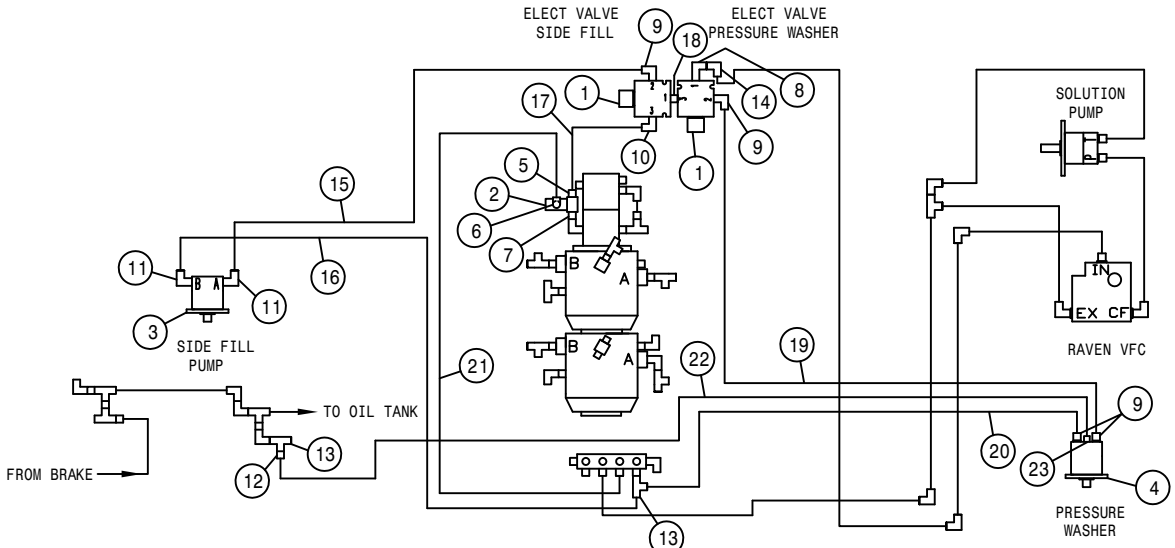

SIDE FILL AND PRWSSURE WASHER OPTION

DET.	QTY	PART NO.	DESCRIPTION	DET.	QTY	PART NO.	DESCRIPTION
1	2	606015	SIDE-FILL/WASH VLV W/SHRD ASSY	13	2	618487	1 1/16FJ SW RUN TEE-1 1/16MJ
2	1	607550	IN-LINE RELIEF VALVE, 2600 PSI	14	1	618191	1 1/16MJ-90-1 1/16FJ SWIV LBO
3	1	690760	BANJO PUMP,3" SIDE FILL STS12	15	1	616129	08-451TC-08FJX-08FJX-204 H/A
4	1	690672	PRESSURE WASHER,PACE 320 HYD	16	1	616130	08-451TC-08FJX-12FJX-204 H/A
5	1	611127	1 1/16MJIC-1 1/16MOR ADPTR	17	1	616131	10-451TC-12FJX-12FJX-14 H/A
6	1	618279	1 1/16MJIC-90-7/8MOR LBO	18	1	618675	1 1/16MOR UNION
7	1	618578	1 1/16FJIC SWIV-1 1/16MOR	19	1	616135	08-451TC-08FJX-08FJX-50 H/A
8	1	618248	1 1/16MJIC-90-1 1/16MOR LBO	20	1	616134	08-451TC-08FJX-12FJX-60 H/A
9	4	618474	3/4MJIC-90-1 1/16MOR LBO	21	1	616132	08-451TC-12FJX-12FJX-18 H/A
10	1	618674	1 1/16MJIC-90-1 1/16MOR XL LBO	22	1	616089	04-451TC-06FJX-06FJX-60 H/A
11	2	618183	3/4MJIC-90-7/8MOR LBO	23	1	618119	9/16MJIC-90-9/16MOR LBO
12	1	618483	1 1/16FJIC-9/16MJIC ADPTR				

SIDE FILL OPTION

DET.	QTY	PART NO.	DESCRIPTION	DET.	QTY	PART NO.	DESCRIPTION
1	1	606015	SIDE-FILL/WASH VLV W/SHRD ASSY	8	1	618474	3/4MJIC-90-1 1/16MOR LBO
2	1	607550	IN-LINE RELIEF VALVE, 2600 PSI	9	1	618674	1 1/16MJIC-90-1 1/16MOR XL LBO
3	1	690760	BANJO PUMP,3" SIDE FILL STS12	10	2	618183	3/4MJIC-90-7/8MOR LBO
4	1	611127	1 1/16MJIC-1 1/16MOR ADPTR	11	1	616132	08-451TC-12FJX-12FJX-18 H/A
5	1	618279	1 1/16MJIC-90-7/8MOR LBO	12	1	616130	08-451TC-08FJX-12FJX-204 H/A
6	1	618578	1 1/16FJIC SWIV-1 1/16MOR	13	1	616131	10-451TC-12FJX-12FJX-14 H/A
7	1	618248	1 1/16MJIC-90-1 1/16MOR LBO	14	1	616129	08-451TC-08FJX-08FJX-204 H/A

PRESSURE WASHER OPTION

DET.	QTY	PART NO.	DESCRIPTION	DET.	QTY	PART NO.	DESCRIPTION
1	1	606015	SIDE-FILL/WASH VLV W/SHRD ASSY	10	1	618483	1 1/16FJIC-9/16MJIC ADPTR
2	1	607550	IN-LINE RELIEF VALVE, 2600 PSI	11	1	618487	1 1/16FJ SW RUN TEE-1 1/16MJ
3	1	690672	PRESSURE WASHER,PACE 320 HYD	12	1	616089	04-451TC-06FJX-06FJX-60 H/A
4	1	611127	1 1/16MJIC-1 1/16MOR ADPTR	13	1	616131	10-451TC-12FJX-12FJX-14 H/A
5	1	618279	1 1/16MJIC-90-7/8MOR LBO	14	1	616135	08-451TC-08FJX-08FJX-50 H/A
6	1	618578	1 1/16FJIC SWIV-1 1/16MOR	15	1	616134	08-451TC-08FJX-12FJX-60 H/A
7	1	618248	1 1/16MJIC-90-1 1/16MOR LBO	16	1	616132	08-451TC-12FJX-12FJX-18 H/A
8	3	618474	3/4MJIC-90-1 1/16MOR LBO	17	1	618119	9/16MJIC-90-9/16MOR LBO
9	1	618674	1 1/16MJIC-90-1 1/16MOR XL LBO				

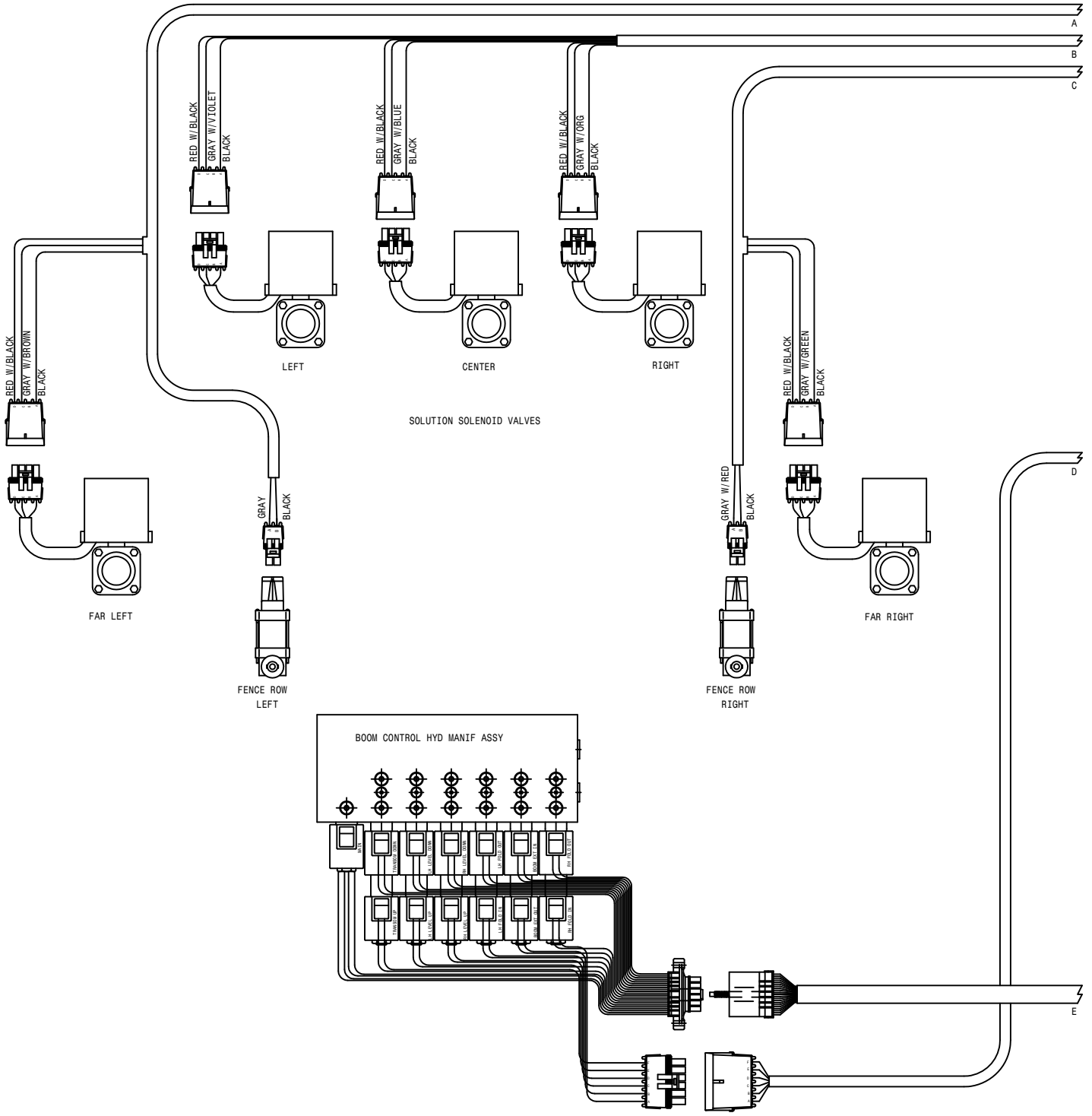

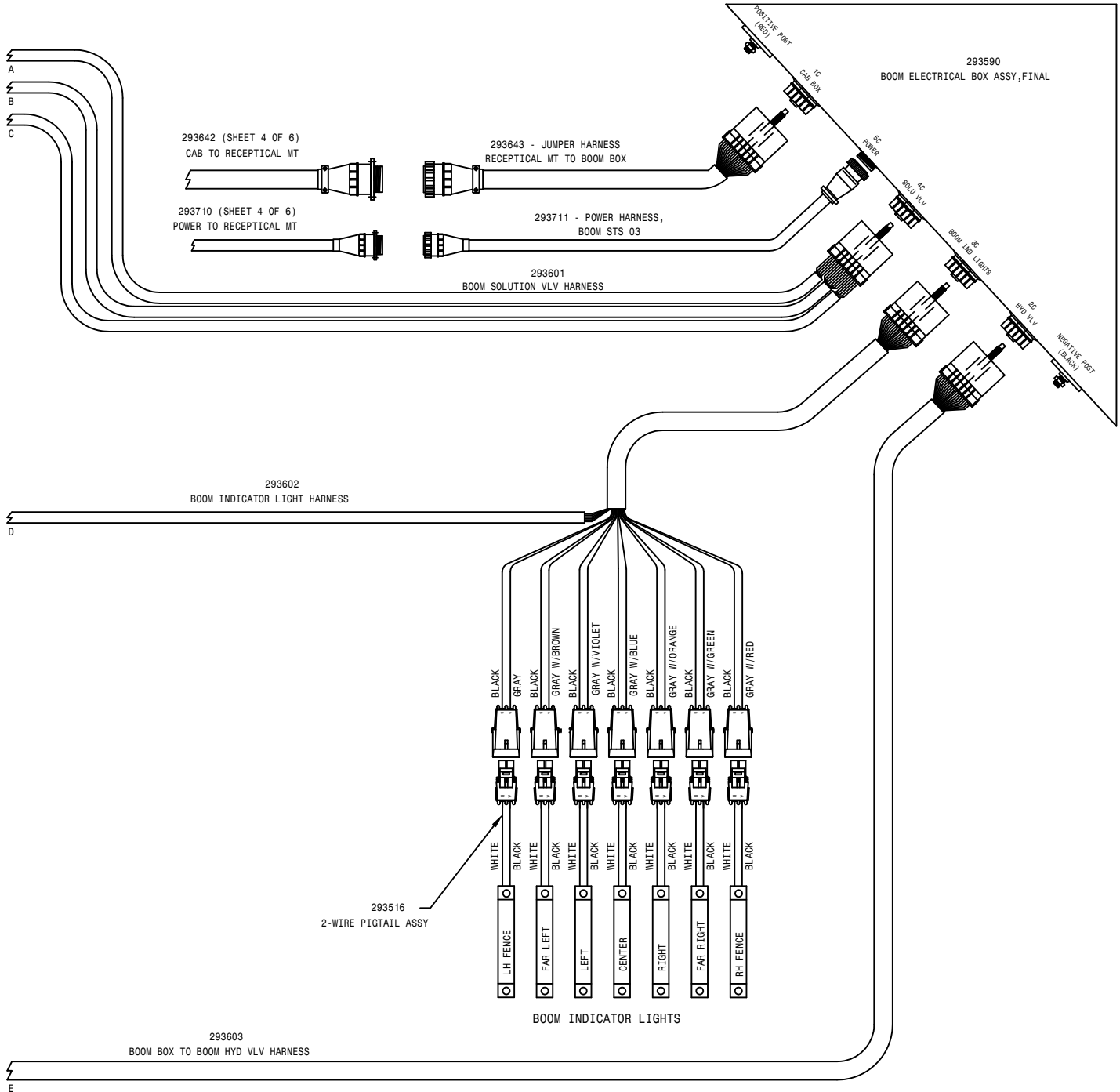

06-20-02 TLM
 STS 10 WIRING DIAGRAM 03
 SHEET 1 OF 6
 REVISION DATE: 498712

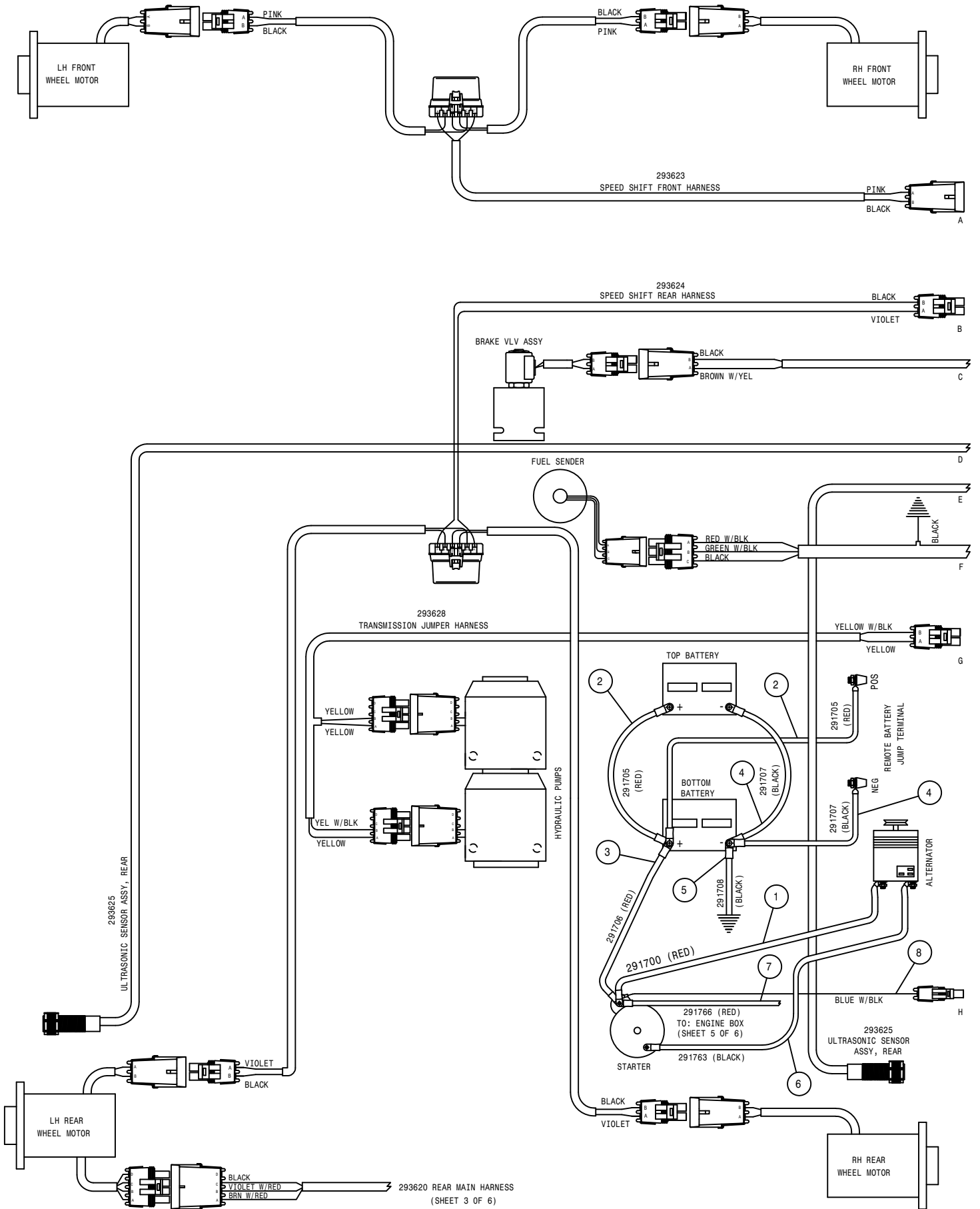

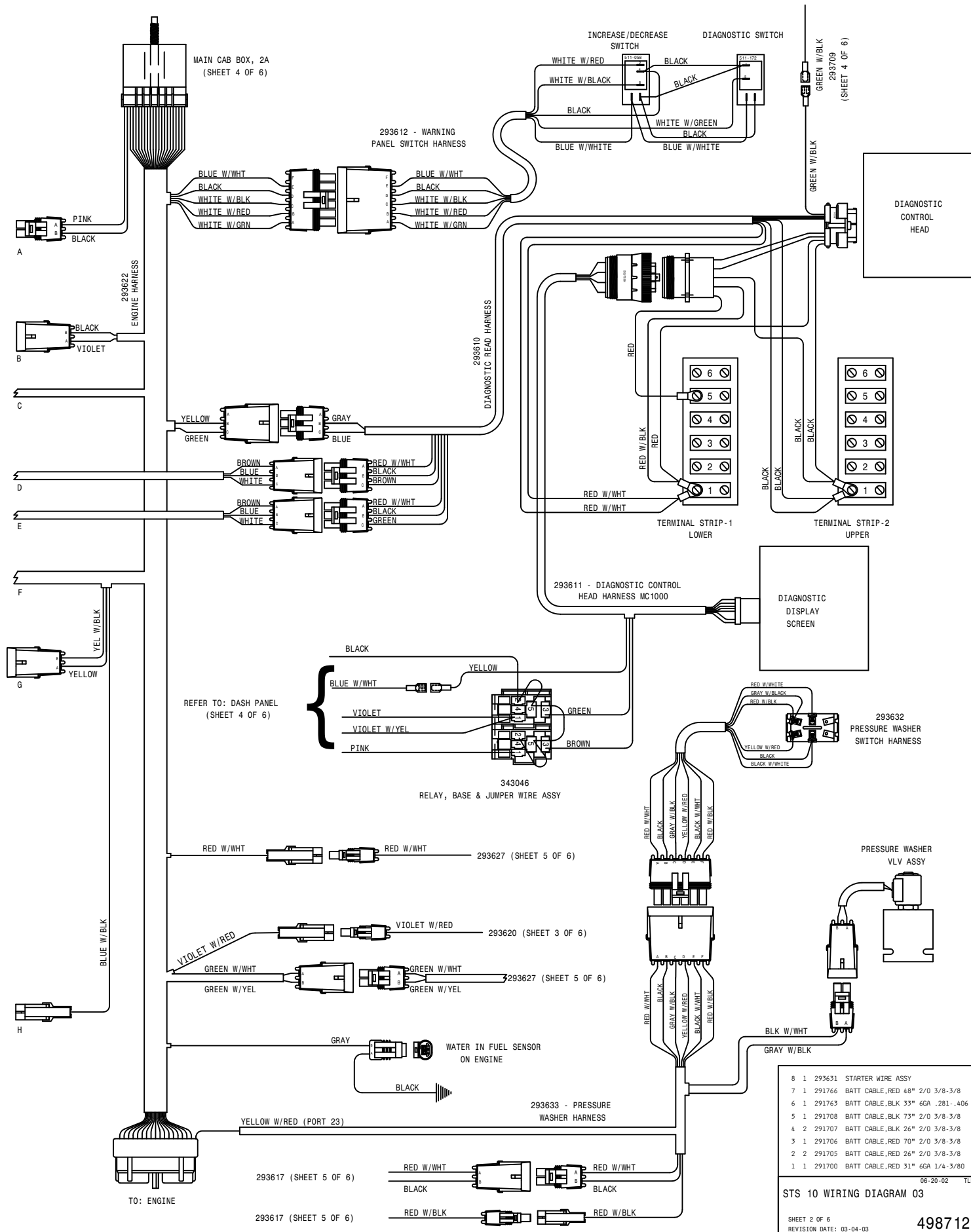

8	1	293631	STARTER WIRE ASSY
7	1	291766	BATT CABLE, RED 48" 2/0 3/8-3/8
6	1	291763	BATT CABLE, BLK 33" 6GA .281-.406
5	1	291708	BATT CABLE, BLK 73" 2/0 3/8-3/8
4	2	291707	BATT CABLE, BLK 26" 2/0 3/8-3/8
3	1	291706	BATT CABLE, RED 70" 2/0 3/8-3/8
2	2	291705	BATT CABLE, RED 26" 2/0 3/8-3/8
1	1	291700	BATT CABLE, RED 31" 6GA 1/4-3/80

06-20-02 TLM
STS 10 WIRING DIAGRAM 03
 SHEET 2 OF 6
 REVISION DATE: 03-04-03

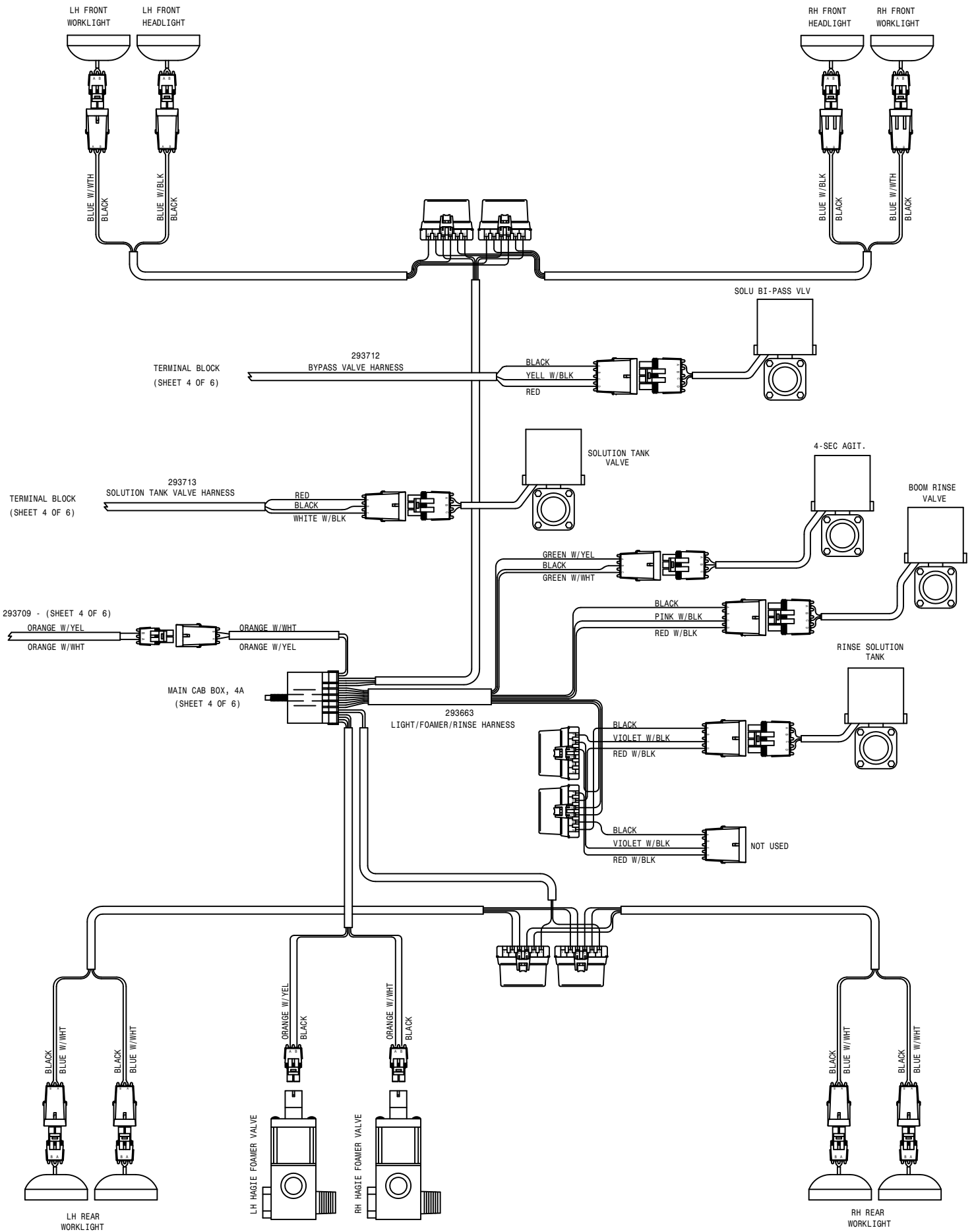

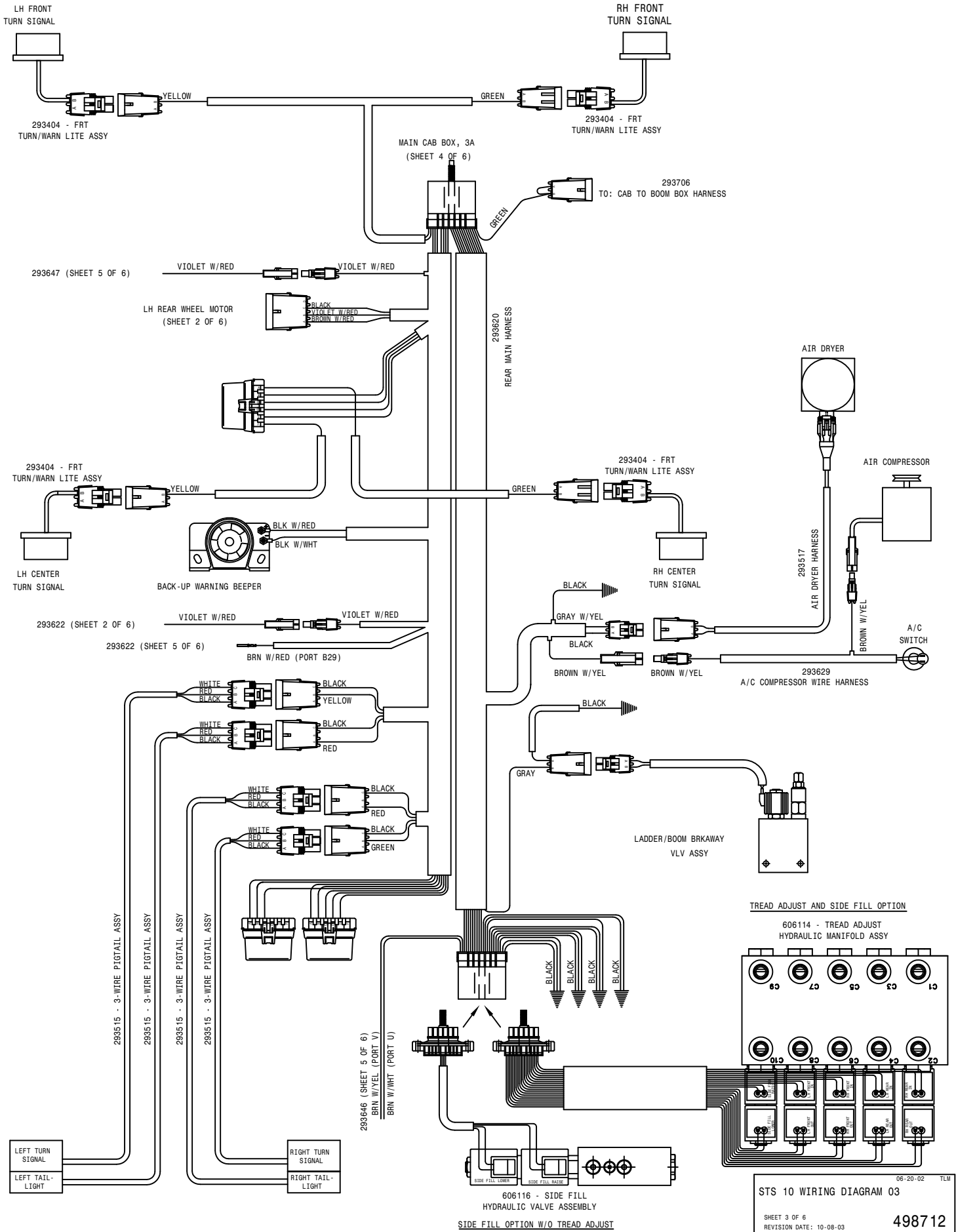

06-20-02 TLM
STS 10 WIRING DIAGRAM 03
 SHEET 3 OF 6
 REVISION DATE: 10-08-03
498712

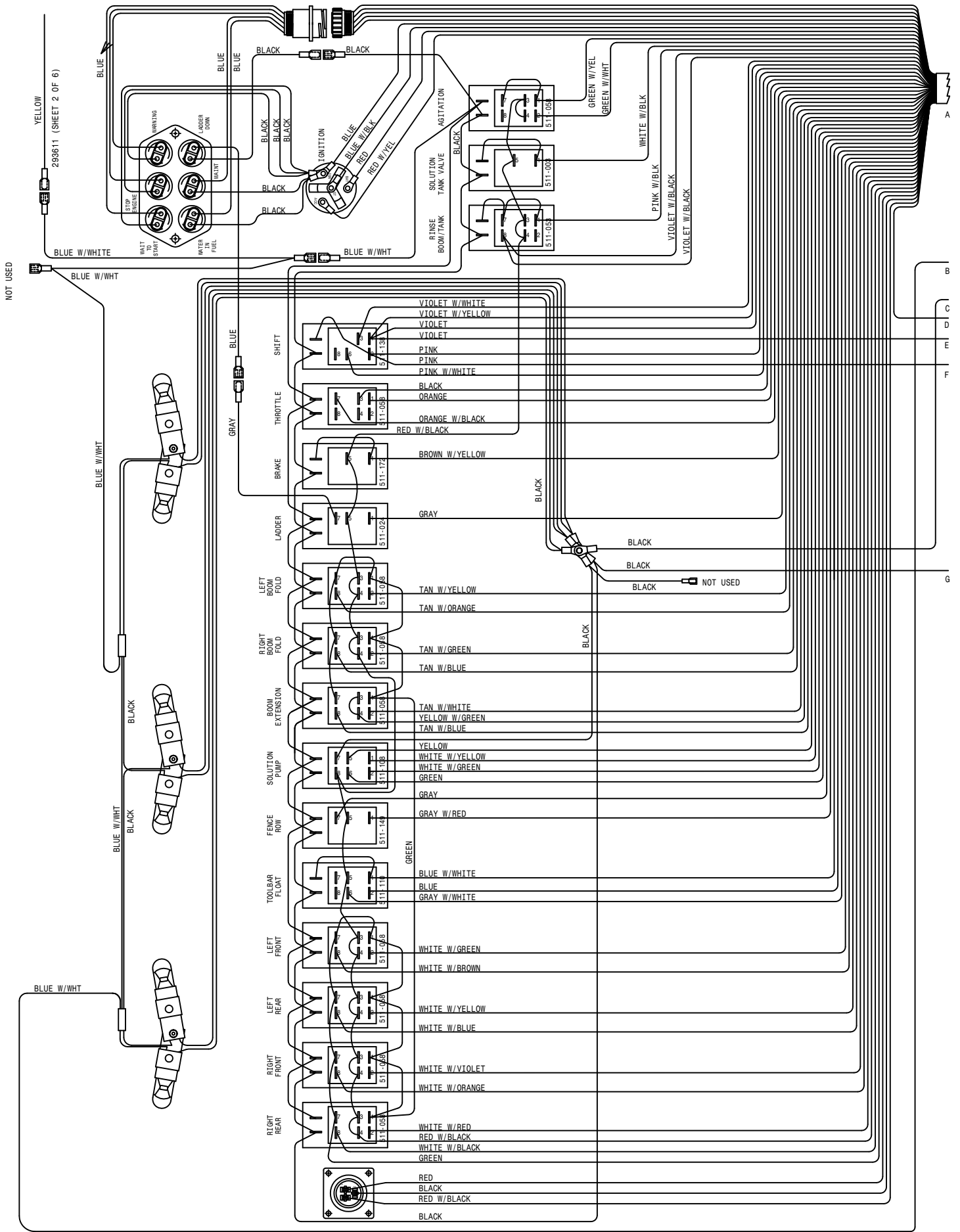

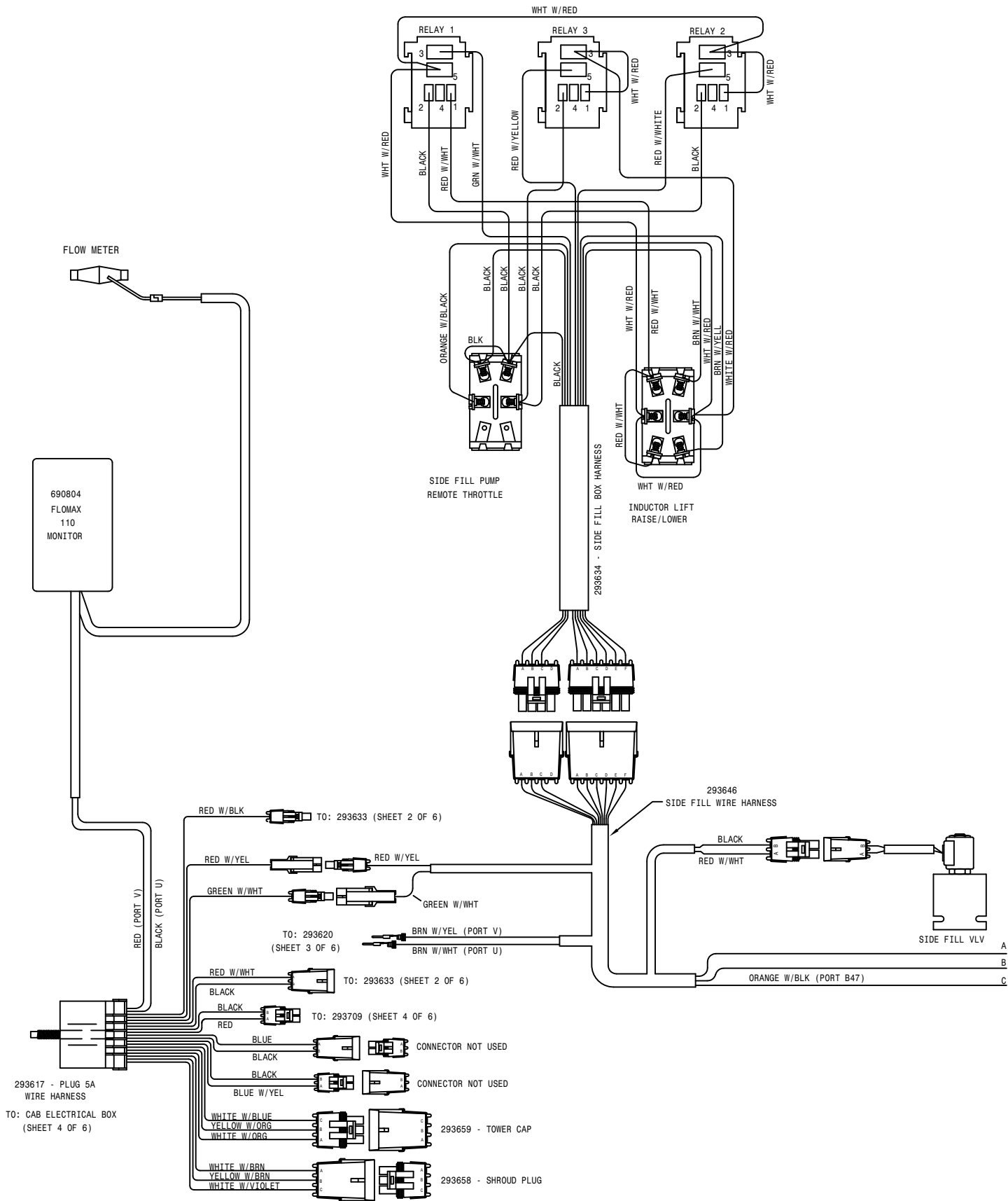

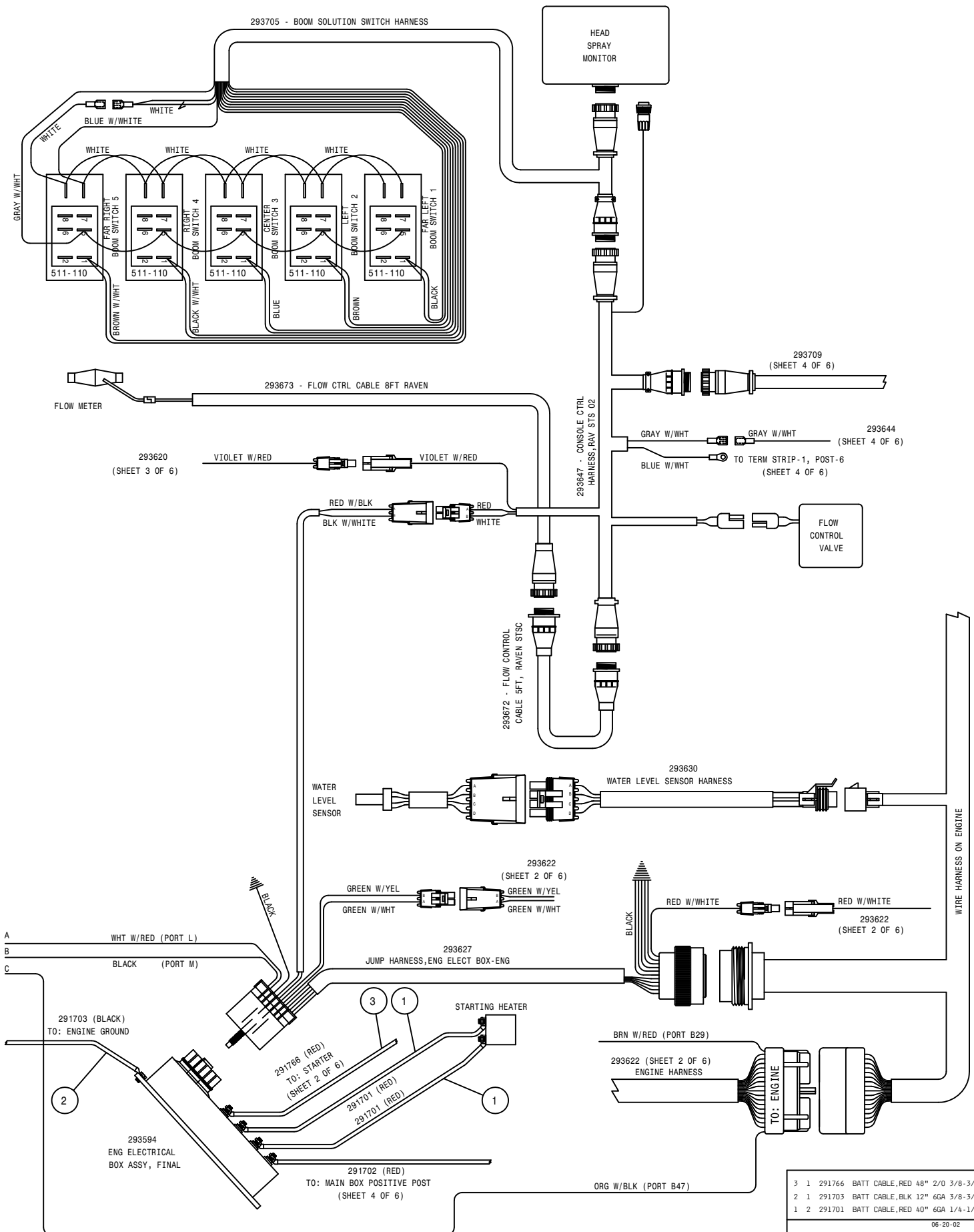

3	1	291766	BATT CABLE, RED 48" 2/0 3/8-3/8
2	1	291703	BATT CABLE, BLK 12" 6GA 3/8-3/8
1	2	291701	BATT CABLE, RED 40" 6GA 1/4-1/4

06-20-02 TLM

STS 10 WIRING DIAGRAM 03

SHEET 5 OF 6
REVISION DATE: **498712**

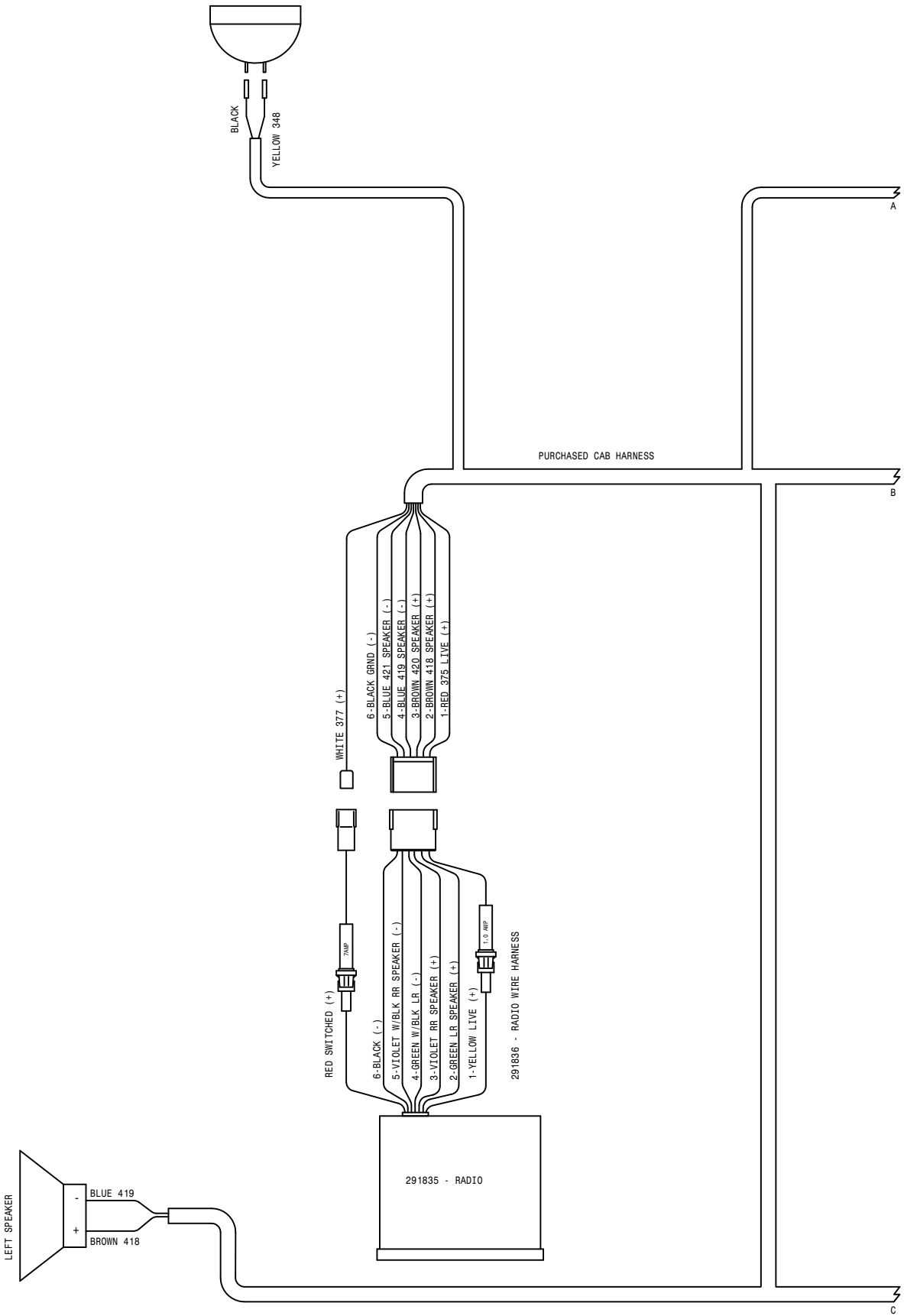

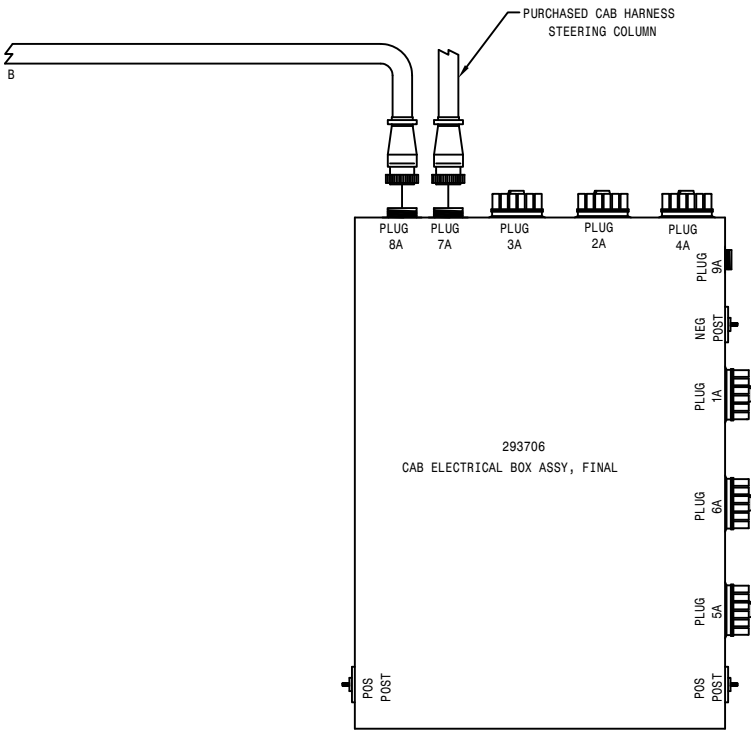

06-20-02 TLM
 STS 10 WIRING DIAGRAM 03
 SHEET 6 OF 6
 REVISION DATE: 498712

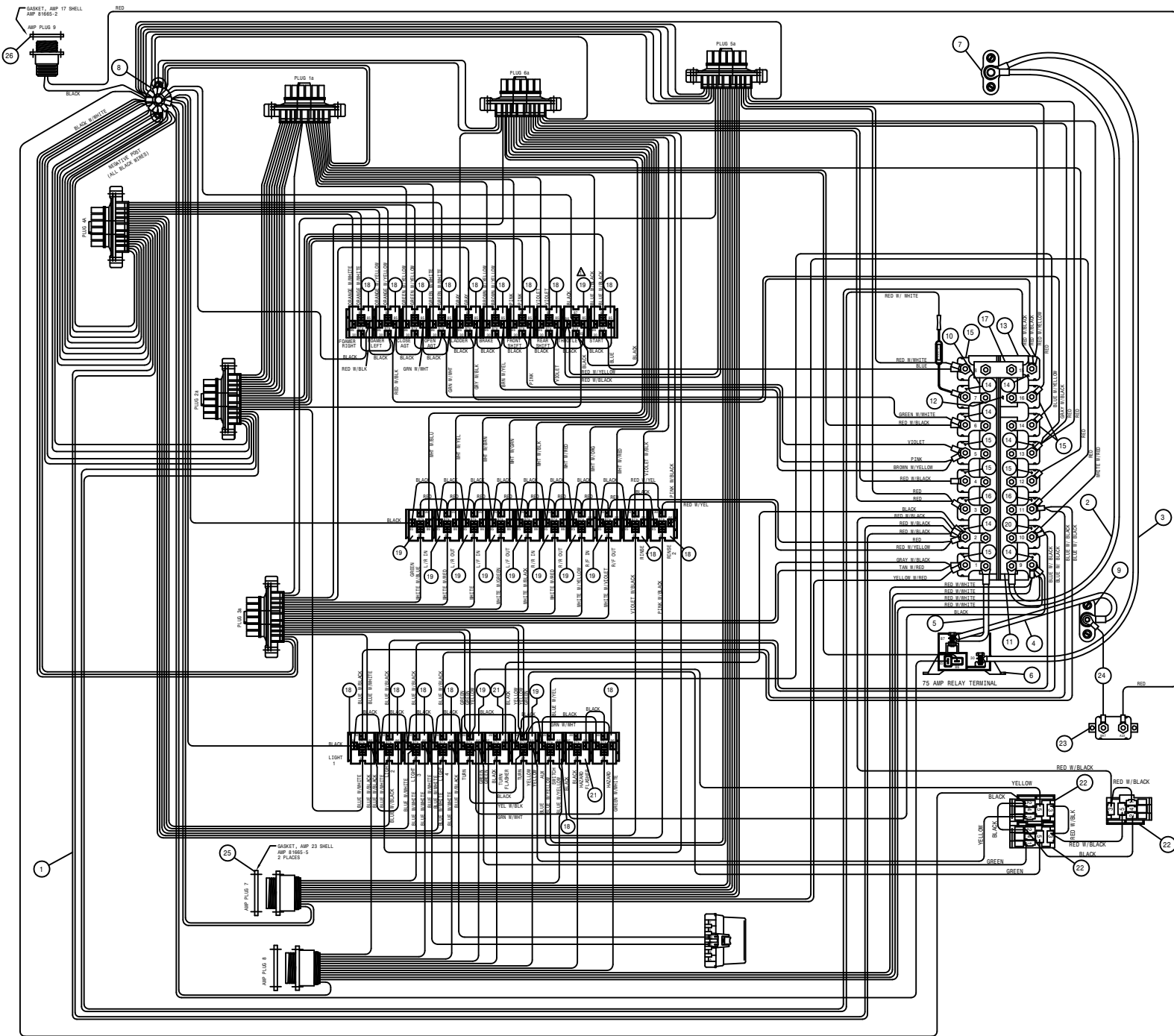

26	1	291846	GASKET, AMP 17 SHELL
25	2	291847	GASKET, AMP 23 SHELL
24	1	293714	12GA RED-291561-291587-9
23	1	291197	CIRCUIT BREAKER, 30AMP, IN-LINE
22	3	291781	MICRO RELAY, BOSCH 12V SPDT
21	2	291564	FLASHER, 12V 3-PIN ELECTRONIC
20	1	291584	CIRCUIT BREAKER, 40AMP W/O MT
19	11	291752	RELAY, SPDT 12V 50A-ND 5-TERM
18	17	291751	RELAY, SPST 12V 40A-ND 5-TERM
17	1	291683	BUSS BAR, 2-GANG CIRCUIT BREAKER
16	2	291574	CIRCUIT BREAKER, 30AMP W/O MT
15	7	291573	CIRCUIT BREAKER, 20AMP W/O MT
14	6	291575	CIRCUIT BREAKER, 10AMP W/O MT
13	2	291757	BREAKER MTG BRKT, 8-GANG NYLON
12	1	291796	BUSS BAR, 2-GANG FOR 291757
11	1	291797	BUSS BAR, 6-GANG FOR 291757
10	1	291758	BUSS BAR, 8-GANG FOR 291757
9	1	291748	TERM BLOCK, BLACK, 1/4-20 THRU
8	1	291749	TERM BLOCK, BLACK, 3/8-16 THRU
7	1	291750	TERM BLOCK, RED, 3/8-16 THRU
6	1	657371	RELAY, 12 VOLT 75 AMP
5	1	291801	BATT CABLE, RED 7*6GA, 218-.218
4	1	291803	BATT CABLE, RED 9*6GA, 218-.250
3	1	291809	BATT CABLE, RED 20*6GA, 218-.375
2	1	291808	BATT CABLE, RED 18*6GA, 218-.375
1	1	293708	MAIN CAB BOX HARNESS (293707)

DET	REQ	DESCRIPTION
HAGIE		
HAGIE MANUFACTURING COMPANY		
CLARION, IOWA 50525		
REMOVE ALL SHARP CORNERS & BURRS		
TOLERANCE UNLESS OTHERWISE SPECIFIED		
FRACTION	± 1/32	DECIMALS X.XX .50 X.XXX .005
ANGLES	° *	
DESCRIPTION OFF-SITE PARTS/ASSY 03 FOR 293706		
DRAWN BY T. MARKER	SCALE NONE (1)	APPROVED BY
CHECKED BY		
DATE 07-26-02	DRAWING NUMBER 293707	
SHEET	OF	

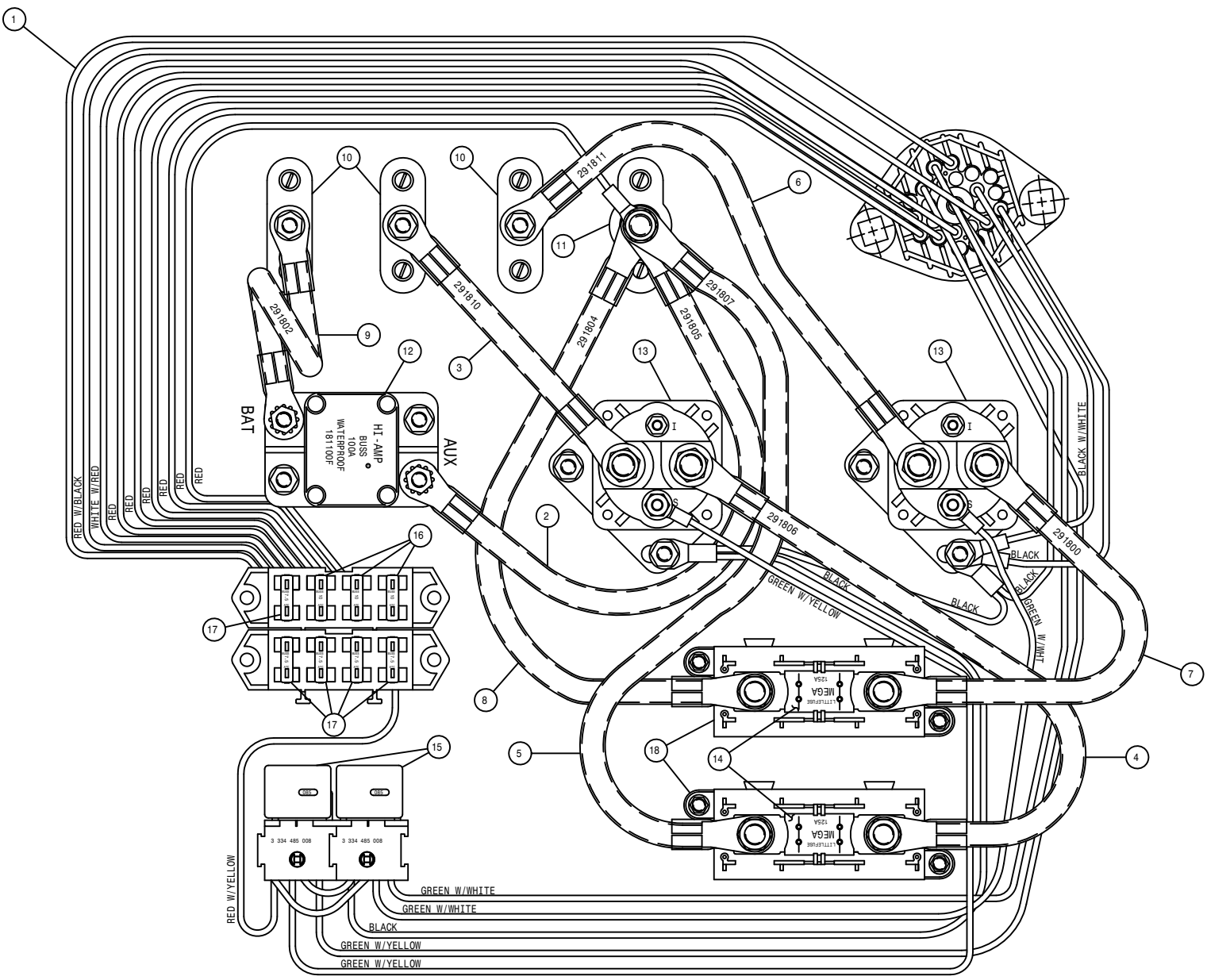

18	2	291814	FUSE HOLDER, HIGH AMP
17	5	291027	7.5 AMP FUSE, 1/4"BLADE ATD/ATC
16	3	291545	10 AMP FUSE, 1/4"BLADE ATD/ATC
15	2	291751	RELAY, SPST 12V 40A-ND 5-TERM
14	2	291813	125 AMP FUSE
13	2	291816	SOLENOID
12	1	291815	CIRCUIT BREAKER, 100 AMP BUSS
11	1	291750	TERM BLOCK, RED, 3/8-16 THRU
10	3	291748	TERM BLOCK, BLACK, 1/4-20 THRU
9	1	291802	BATT CABLE, RED 8*6GA.281-.281
8	1	291804	BATT CABLE, RED 9*6GA.343-.406
7	1	291800	BATT CABLE, RED 4*6GA.343-.343
6	1	291811	BATT CABLE, BLK 8*6GA.281-.343
5	1	291807	BATT CABLE, RED 12*6GA.343-.406
4	1	291806	BATT CABLE, RED 11*6GA.343-.343
3	1	291810	BATT CABLE, BLK 5*6GA.281-.343
2	1	291805	BATT CABLE, RED 11*6GA.281-.406
1	1	293626	ENGINE BOX HARNESS (342850)

DET	RED	DESCRIPTION
HAGIE		
HAGIE MANUFACTURING COMPANY		
CHAFFIN, IOWA 52525		
REMOVE ALL SHARP CORNERS & BURRS		
TOLERANCE UNLESS OTHERWISE SPECIFIED		
FRACTION	+ 1/32	DECIMALS
		ANGLES
DESCRIPTION		
OFF-SITE PARTS/ASSY FOR 293594		
DRAWN BY	C. ADAMS	SCALE
CHECKED BY		NONE (1)
DATE	01-20-00	APPROVED BY
DRAWING NUMBER		293595
SHEET		OF

ABBREVIATIONS

A/C - AIR CONDITIONER	MT - MOUNT
ADPTR - ADAPTER	MTR - MOTOR
AGI - AGITATOR	P/N - PART NUMBER
ALT - ALTERNATOR	PLT - PLATE
ASSY - ASSEMBLY	QTY - QUANTITY
BRKT - BRACKET	RED - REDUCER
DET - DETAIL	REF - REFERENCE
DISPL - DISPLACEMENT	REST - RESTRICTOR
EL - ELBOW	REQ - REQUIRED
EXT - EXTENSION	SHFT - SHAFT
FLO - FLOW	SOL - SOLUTION
FNPT - FEMALE NATIONAL PIPE THREAD	STRG - STEERING
FOR - FEMALE O-RING	ST - STREET
FRT - FRONT	SWIV - SWIVEL
HYD - HYDRAULIC	UNC - UNIFIED NATIONAL COURSE
HYDRO - HYDROSTATIC	UNF - UNIFIED NATIONAL FINE
LG - LONG	V - VOLT
LWR - LOWER	W/ - WITH
MJIC - MALE J.I.C.	WHL - WHEEL
MOR - MALE O-RING	WLD - WELDMENT

INDEX

-A-

ABBREVIATIONS.....145
ACCUMULATOR.....90
AIR DRYER.....16
AIR CLEANER.....10
 FILTER.....10
AIR COMPRESSOR GOVERNOR.....10
AIR CONDITIONER
 BINARY SWITCH.....9
 COMPRESSOR.....7
 CONDENSOR COIL.....12
 HOSE.....9,12
 RECEIVER/DRYER.....9
 TUBE.....31
AIR COOLER, CHARGE.....12
AIR PRESSURE GAUGE.....40,83
AIR REGULATOR, FOAMER.....83
AIRRIDE SPRING.....20,22,24,26
AIR VALVE.....20,22,24,26
ALTERNATOR.....5
ARM, STEERING.....20,22,24,26
ATI CONTROLER.....45

-B-

BACK-UP BEEPER.....12
BALL VALVE.....52,63
 ELECTRIC.....53,58,59,60,64
BATTERY.....15
 CABLE.....4,5,10,15
 BOX PANEL.....12
BEARING,
 BRONZE LEG.....20,22,24,26,32
 ORKOT.....20,22,24,26
BELT,
 AIR CONDITIONER.....7
 DRIVE.....5
BLOCK, TERMINAL.....40
BOOM.....91,92,93,94
 CRADLE.....95,96,97
 INDICATOR LIGHT.....87
 PIN.....93,94,96
 VALVE.....88
BOX,
 BOOM SWITCH.....43
 ELECTRICAL.....35,36,37
 PRESSURE WASHER.....103
 SIDE FILL.....109
BRACE, RADIATOR.....9
BREAKAWAY CYLINDER.....94,102
BUMPER, REAR.....49

-C-

CAB.....39
 FILTER.....39
 STABILIZER.....39
CABLE BATTERY.....4,5,10,15
CAP,
 FUEL.....13
 RADIATOR.....12
CHARGE AIR COOLER.....12
CHEMICAL INDUCTOR.....110
COMPRESSOR, A/C.....7
CONDENSOR COIL, A/C.....12
CONTROLER, ATI.....45
COOLER, OIL.....12
CRADLE, BOOM.....95,96,97
CYLINDER,
 BREAKAWAY.....94,102
 FOLD.....90,93,99,101
 GAS.....48
 LEVEL.....90,100
 LIFT.....89,98
 SIDE FILL.....110,113
 STEERING.....20,22,28
 TREAD ADJUST.....32,33

-D-

DECALS.....120,121
DIAGRAMS, WIRING.....130
DIPSTICK, HYDRAULIC.....14
DOOR LATCH.....48
DRAIN COCK, AIR.....16
DRIVE
 BELT.....5
 DISK.....4

-E-

ELECTRIC BALL VALVE...52,57,59,60
ELECTRICAL BOX,
 BOOM.....35
 CAB.....37
 ENGINE.....36
ENGINE.....4,5
 SKID.....9

-F-

FAN.....5
 SPACER.....5

FEEDER TEE.....61,62,66,67
 FENCE ROW NOZZLE.....70,71
 FENDER.....116,117
 FILTER,
 AIR CLEANER.....10
 CAB.....39
 FUEL.....4
 HYDRAULIC.....18,34
 MINDER.....10
 OIL.....5,14
 FLASHER.....30,49
 FLOW METER.....59,64
 FOAMER
 AIR REGULATOR.....83
 DROP HOSE.....86
 HOSING.....81
 TANK.....82
 THREE-WAY VALVE.....82
 VALVE.....82
 FOLD CYLINDER.....90,93,99
 FRAME, SHEETMETAL.....49
 FRESH WATER.....83
 FRONT FILL.....114
 FUEL,
 CAP.....13
 SENDER.....13
 TANK.....13

-G-

GAS CYLINDER.....48
 GAUGE,
 AIR PRESSURE.....40,83
 SOLUTION.....59,64

-H-

HANDRAIL.....50
 HEATER TUBE.....31
 HOSE, A/C.....9
 HOSING,
 FOAMER.....76
 SOLUTION.....72,73,76,78
 HUB, TORQUE.....21,23,25,27
 HYDRAULIC,
 FILTER.....18
 LEVER.....42
 SCHEMATIC.....122
 TANK.....14
 TUBE.....30,31,89,92
 VALVE.....19
 HYDROSTATIC PUMP.....8

-I-

IGNITION SWITCH.....44
 INDICATOR LIGHT, BOOM.....83
 INLINE, HYDRAULIC FILTER.....34

-L-

LADDER.....51
 LEG.....20,22,24,26
 LEVEL CYLINDER.....90,100
 LEVER, HYDROSTATIC.....42
 LIFT CYLINDER.....89,91
 LIFTARM.....89
 LIGHT.....30,95
 LINE STRAINER.....53,56,58
 LIQUID LEVEL SWITCH.....14

-M-

MIRROR.....46,47
 MONITOR, SPRAYER.....45
 MOTOR,
 STEERING.....39
 WHEEL.....21,23,25,27
 MOUNT, RUBBER.....9,12
 MUFFLER.....11

-N-

NOZZLE,
 BODY.....69
 FENCE ROW.....70,71
 MOUNT TUBE.....92,93,94
 REAR WHEEL.....62,68

-O-

OIL COOLER.....12
 OIL FILTER.....5,14

-P-

PANEL,
 BATTERY BOX.....12
 RECEPTACLE.....38
 SWITCH.....44
 PLATFORM, SERVICE.....50
 PRESSURE GAUGE.....59,64
 PRESSURE WASHER.....104
 BOX.....103
 VALVE.....106,107
 PUMP,
 HYDRAULIC.....6
 HYDROSTATIC.....8
 SIDE FILL.....110,111
 SOLUTION.....57

-R-

RADIATOR.....12
 BRACE.....9
 CAP.....12
 HOSE.....5

RADIO.....41
 REAR WHEEL NOZZLE.....62
 RECEPTACLE PANEL.....38
 RECOVERY TANK.....48
 RINSE TANK.....53
 RUBBER
 MOUNT.....9,12
 SPRING.....20,22,24,26

-S-

SCHEMATIC, HYDRAULIC.....122
 SENDER, FUEL.....13
 SENDER, WATER LEVEL.....12
 SERVICE PLATFORM.....50
 SHEET METAL.....48,49
 SHIELD, WHEEL MOTOR...21,23,25,27
 SIDFILL.....110,111
 BOX.....109
 CYLINDER.....110,111
 SIGHT GAUGE.....14,55
 SKID, ENGINE.....9
 SMV SIGN.....49
 SOLUTION
 HOSE.....72,73,74,75
 PUMP.....57
 TANK.....52,54,61
 VALVE.....59,60,64
 SPACER, FAN.....5
 SPEAKER.....41
 SPRAY MONITOR.....45
 SPRING,
 AIRRIDE.....20,22,39
 SOLUTION TANK.....52
 STABILIZER, CAB.....42
 STARTER.....5
 STEERING,
 ARM.....20,22,24,26
 CYLINDER.....20,22,28
 MOTOR.....39
 STRAINER, LINE.....53,56,58
 SWITCH,
 A/C BINARY.....9
 BOX, BOOM.....43
 IGNITION.....43
 LIQUID LEVEL.....14
 PANEL.....43

-T-

TAILLIGHT.....49
 TANK
 AIR.....16
 FOAMER.....82
 FRESHWATER.....83
 FUEL.....13

HYDRAULIC.....14
 RECOVERY.....48
 RINSE.....53
 SOLUTION.....52,54
 TERMINAL BLOCK.....40
 TIRE.....29
 TORQUE HUB.....21,23,25,27
 TRANSOM.....90
 TREAD ADJUST
 CYLINDER.....32,33
 VALVE.....34
 TUBE,
 A/C.....31
 HEATER.....31
 HYDRAULIC.....30,31,89,92

-V-

VALVE,
 AIR.....20,22,24,26,39
 BALL.....52,63
 BOOM.....88
 ELECTRIC BALL.....53,57,59,64
 FOAMER.....82,84,85
 HYDRAULIC.....9,18
 PRESSURE WASHER.....106,107
 SIDE FILL.....108,112
 SOLUTION.....59,60,63
 TREAD ADJUST.....34

-W-

WASHER, PRESSURE.....104
 WATER LEVEL SENSOR.....12
 WHEELMOTOR.....21,23,25,27
 SHIELD.....21,23,25,27
 WIRING DIAGRAM.....130



PARTS ORDER FAX

Fax
24 hours
a day
7 days
a week*

Ph. 1 (800) 247-4885

Fx. 1 (515) 532-3553

Photocopy and fax to Hagie Customer Support Department

ORDERED BY/BILL TO:

Name _____
 Co. Name _____
 Street _____
 City, St, Zip _____
 Ph. _____ Fx. _____

SHIP TO:

Name _____
 Co. Name _____
 Street _____
 City, St, Zip _____
 Ph. _____ Fx. _____

HOW SHIP: UPS Ground Next Day 2 Day 3 Day Other _____

If "HOW SHIP" is left blank, parts will be sent UPS ground service. If part is over 150 pounds, an independent motor freight company will be used.

PAYMENT: Hagie Account #** _____
 C.O.D

American Express Discover Visa Master Card

Signature: _____
 name as appears on card: _____
 card no. _____ exp. date _____

Year and Model No. _____

Serial No. _____

Item Serial No. (if necessary):

Engine (include type) _____

Hydrostatic Pump (s) _____

Torque Hub _____ LF RF LR RR

Wheel Motor _____ LF RF LR RR

HAGIE Part No.	Qty.	Description

Check here if you want phone confirmation of parts order.

* Orders received before 3:00 p.m., CST will be processed the same business day.
 Regular business hours are Monday through Friday, 7:00 a.m. through 5:00 p.m..

** If you do not have a Hagie account number, contact the Hagie Customer Support Department and you will be issued one.



PARTS ORDER FAX

Fax
24 hours
a day
7 days
a week*

Ph. 1 (800) 247-4885

Fx. 1 (515) 532-3553

Photocopy and fax to Hagie Customer Support Department

ORDERED BY/BILL TO:

Name _____
 Co. Name _____
 Street _____
 City, St, Zip _____
 Ph. _____ Fx. _____

SHIP TO:

Name _____
 Co. Name _____
 Street _____
 City, St, Zip _____
 Ph. _____ Fx. _____

HOW SHIP: UPS Ground Next Day 2 Day 3 Day Other _____

If "HOW SHIP" is left blank, parts will be sent UPS ground service. If part is over 150 pounds, an independent motor freight company will be used.

PAYMENT: Hagie Account #** _____
 C.O.D

American Express Discover Visa Master Card

Signature: _____
 name as appears on card: _____
 card no. _____ exp. date _____

Year and Model No. _____

Serial No. _____

Item Serial No. (if necessary):

Engine (include type) _____

Hydrostatic Pump (s) _____

Torque Hub _____ LF RF LR RR

Wheel Motor _____ LF RF LR RR

HAGIE Part No.	Qty.	Description

Check here if you want phone confirmation of parts order.

* Orders received before 3:00 p.m., CST will be processed the same business day.
 Regular business hours are Monday through Friday, 7:00 a.m. through 5:00 p.m..

** If you do not have a Hagie account number, contact the Hagie Customer Support Department and you will be issued one.