

PARTS MANUAL
FOR
HAGIE MODEL STS 10 HI-TRACTOR
SPRAYER – DETASSELER

HAGIE MANUFACTURING COMPANY

BOX 273 CLARION, IOWA 50525

(515) 532-2861

COVERS MACHINE SERIAL NUMBERS: U1660220001 thru U1660220100

04-02 493250
02-08

SPRAYER IDENTIFICATION

Each Hagie sprayer is identified by means of a frame serial number. This serial number denotes the model, the year in which it was built, and the number of the sprayer. As for further identification, the engine has a serial number and the planetary hubs have identification plates that describe the type of mount and gear ratio. To insure prompt, efficient service when ordering parts or requesting service repairs from Hagie Manufacturing Company, record the serial and identification numbers in the space provided below.

NOTE: Reference to left hand and right hand used throughout this manual refers to the position when seated in the operator's seat facing forward.

SPRAYER SERIAL NUMBER

ENGINE SERIAL NUMBER

PLANETARY HUB IDENTIFICATION NUMBERS

TABLE OF CONTENTS

ENGINE ASSEMBLY 4-11

RADIATOR AND OIL COOLER ASSEMBLY. 12

AIR TANK ASSEMBLY 13

FUEL AND OIL TANK ASSEMBLY. 14-15

BATTERY. 16

HI-PRESS FILTER ASSEMBLY 17

LADDER AND BRAKE VALVE ASSEMBLY 18-19

LEG ASSEMBLY 20-27

STEERING CYLINDER. 28

TIRE ASSEMBLY 29

HYDRAULIC TUBING 30-31

TREAD ADJUST ASSEMBLY 32-35

ELECTRICAL BOXES 36-38

CAB ASSEMBLY. 39-42

SWITCH PANEL ASSEMBLY 43

ATI CONTROLER BOX ASSEMBLY 44

LS CONTROL BOX 45

MIRROR BRACKETS 46-47

SHEET METAL 48-49

SERVICE PLATFORM. 50

LADDER ASSEMBLY. 51

SOLUTION TANK 52-55

SOLUTION PUMP AND ELECTRIC VALVES 56-73

SOLUTION HOISING 74-81

FOAMER TANK ASSEMBLY. 82-88

TRANSOM, BOOM, AND LIFT COMPONENTS. 89-105

PRESSURE WASHER OPTION. 106-110

SIDE FILL/CHEMICAL INDUCTOR OPTION. 111-116

FRONT FILL OPTION. 117

RADAR OPTION. 118

FENDER OPTION 119-120

FLOW MAX 110 MONITOR ASSEMBLY 121

BG420 FLOW DIVIDER ASSEMBLY AND MANIFOLD ASSEMBLY. 122-123

RECEPTICLE PANEL AND BOX ASSEMBLY 124-125

FOLD AND LIFT VALVE ASSEMBLY 126-129

MOTOR CONTROL VALVE ASSEMBLY 130

OUTRIGGER ASSEMBLY 131-135

QUAD AND CUTTER HEAD ASSEMBLY 136-138

CUTTER CASE DRAIN MANIFOLD ASSEMBLY 139

DECALS. 140-141

HYDRAULIC SCHEMATIC 142-161

ELECTRICAL SCHEMATIC 162-184

ABBREVIATIONS 185

INDEX. 186

PARTS ORDER FORM. 189

ENGINE ASSEMBLY

DET. QTY PART NO. DESCRIPTION

DET.	QTY	PART NO.	DESCRIPTION
1	1	316360	CUMM ENG,QSB5.9C,275@2500CMPSR
2	1	470118	1/4UNC X 3/4 FLANGE HEX BOLT
3	1	470121	1/4UNC HEX FLANGE LOCK NUT
4	12	473798	10MM LOCK WASHER
5	12	473818	10MM-1.50 X 40MM HEX BOLT
6	2	473767	6MM-1.00 HEX NUT
7	2	473768	6MM LOCK WASHER
8	2	291701	BATT CABLE,RED 40" 6GA 1/4-1/4
9	1	291704	BATT CABLE,BLK 172" 6GA3/8-3/8
10	2	520080	HOSE CLAMP NO 10 STAINLESS
11	2	520120	HOSE CLAMP NO 4 STAINLESS
12	1	611303	08P919-10FJX-10FJX-144 H/A
13	1	601467	HOSE, 5/8 X 69 HEATER
14	1	520121	CUSH HOSE CLAMP 1IN X 3/4W
15	1	711036	1/8MNPT-1/4 NYL TUBE FTG
16	1	800502	PUMP DRIVE,DIRECT SAE#3/C 23T
17	8	900128	3/8UNC X 3/4 HEX BOLT
18	8	920502	3/8 LOCK WASHER
19	1	601474	HOSE, 1/4 X 26 AIR
20	1	800503	DRIVE DISK ASSY,11.5" 23T SPL
21	1	316373	FUEL/WATER SEPERATOR (316360)
22	1	316378	FUEL TRANSFER PUMP FOR 316360

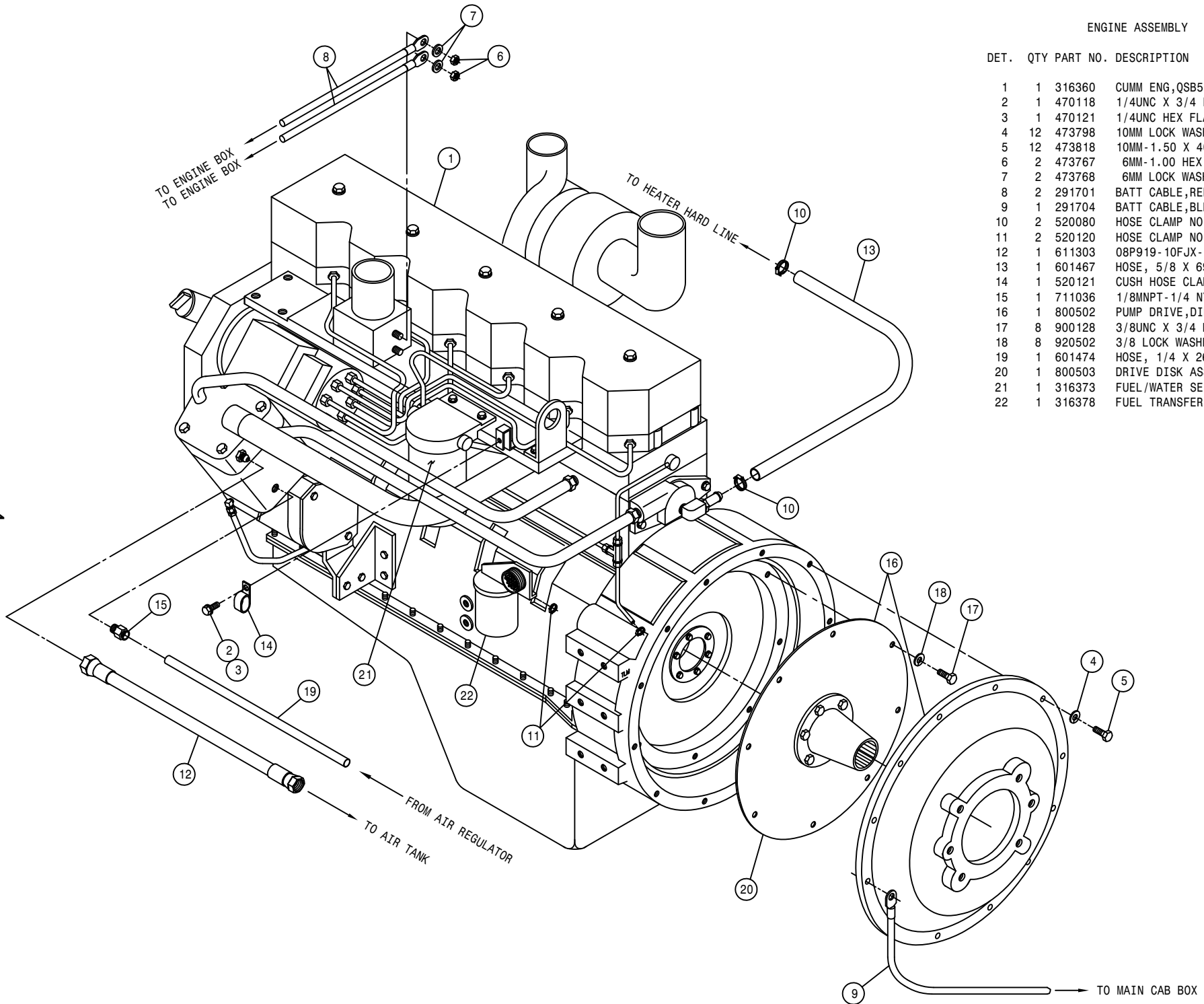

ENGINE ASSEMBLY

DET. QTY PART NO. DESCRIPTION

1	1	314832	RADIATOR HOSE 1.75 X 19
2	1	314987	LWR RADIATOR HOSE STS-12
3	1	316360	CUMM ENG,QSB5.9C,275@2500CMP5R
4	1	316362	FAN SPACER, QSB5.9C STS12 00
5	1	316363	FAN, CUMM QSB5.9C, STS12 2000
6	1	316367	DELCO ALTERNATOR,130 AMP 22SI
7	1	316370	ALT PULLEY, 2.76 OD, 8-GROOVE
8	2	473766	10MM LOCK WASHER,INT TOOTH
9	4	473769	10MM-1.50 X 100MM FLG HEX BOLT
10	1	473770	5MM-.80 HEX NUT
11	1	473796	10MM-1.50 X 16MM HEX BOLT
12	4	473798	10MM LOCK WASHER
13	4	473799	10MM FLAT WASHER
14	1	291700	BATT CABLE,RED 31" 6GA 1/4-3/8
15	1	291706	BATT CABLE,RED 70" 2/0 3/8-3/8
16	1	291766	BATT CABLE,RED 48" 2/0 3/8-3/8
17	1	291708	BATT CABLE,BLK 73" 2/0 3/8-3/8
18	1	291763	BATT CABLE,BLK 33" 6GA 3/8-3/8
19	2	520067	HOSE CLAMP NO 28 STAINLESS
20	1	520069	HOSE CLAMP NO 6 STAINLESS
21	3	520080	HOSE CLAMP NO 10 STAINLESS
22	2	520099	HOSE CLAMP NO 40 STAINLESS
23	1	601468	HOSE, 5/8 X 91 HEATER
24	2	616137	12-421HT-12FJX-12FJX-68 H/A
25	1	316471	STARTER SOLENOID NUT ASSY
26	1	316372	LUBE FILTER (CUMM ENG 316360)
27	2	618302	1 1/16MJIC-90-1 5/16MOR LBO
28	1	316375	DRIVE BELT, QSB5.9C 316360 00
29	1	601529	HOSE, 3/4 X 34 CLEAR VINYL
30	2	618189	1 1/16MJIC-7/8MOR ADPTR
31	2	618191	1 1/16MJ-90-1 1/16FJ SWIV LBO
32	2	473827	8MM-1.25 X 20MM HEX BOLT
33	2	473804	8MM LOCK WASHER
34	1	316524	FAN, CUMM QSB5.9C, STS12 2002
35	1	316525	DRIVE BELT, QSB5.9C 316360 02

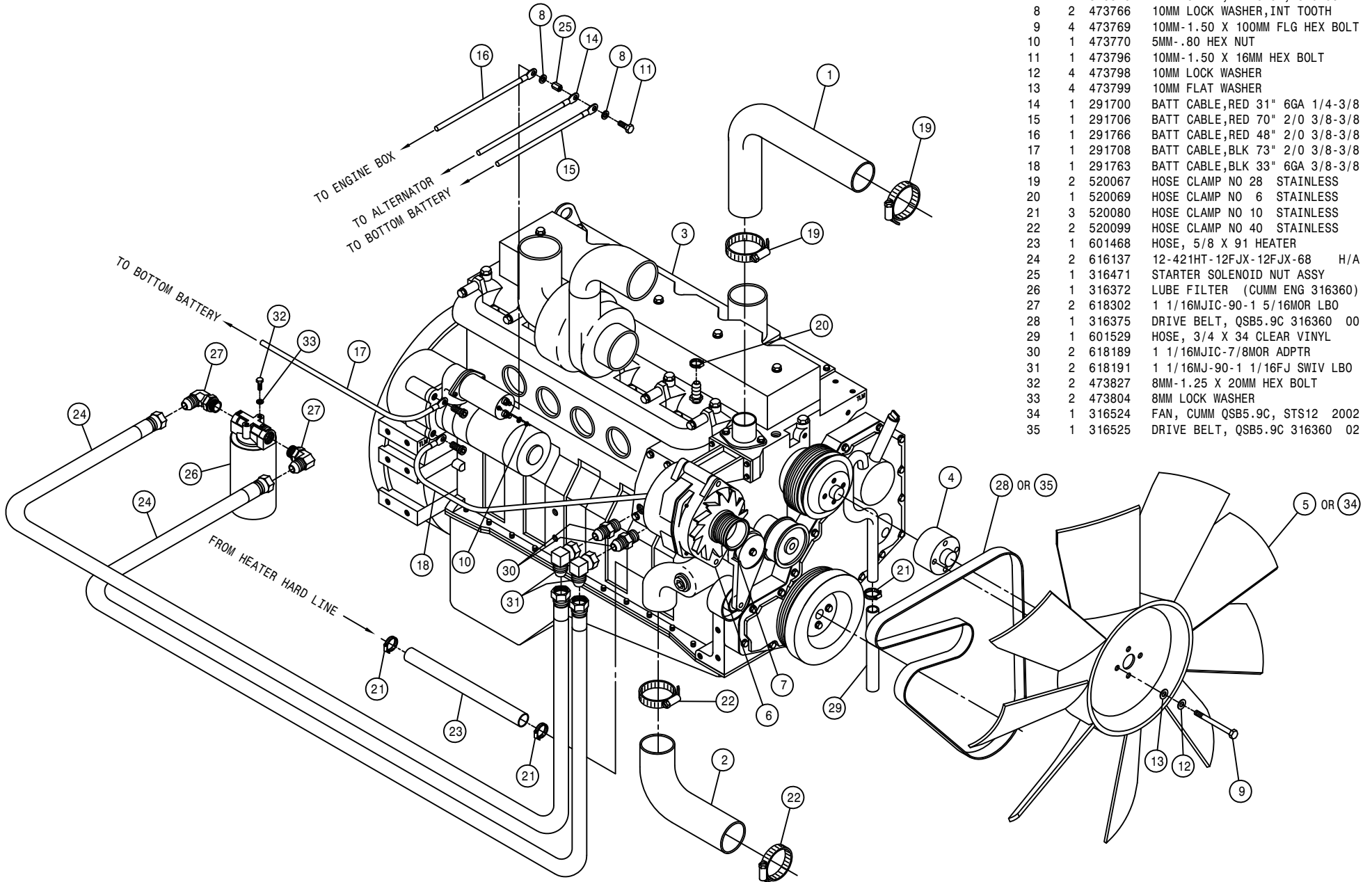

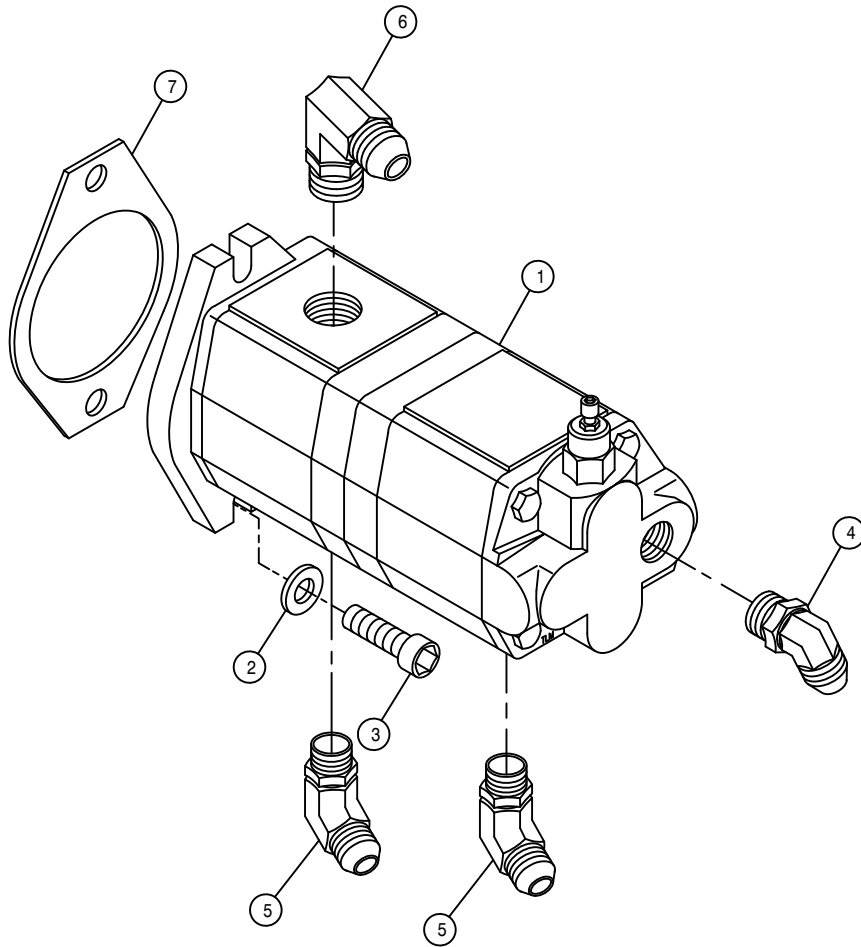

STEERING AND TREAD ADJUST PUMP ASSEMBLY

DET. QTY PART NO. DESCRIPTION

1	1	606990	TANDEM PUMP, .66CI/.51CI
2	2	473799	10MM FLAT WASHER
3	2	473844	10MM-1.50 X 30 SOC HD CAP SCR
4	1	618315	3/4MJIC-45-3/4MOR LBO
5	2	618183	3/4MJIC-90-7/8MOR LBO
6	1	618248	1 1/16MJIC-90-1 1/16MOR LBO
7	1	316371	GASKET, AUX DRIVE CUMM 154916

A/C COMPRESSOR PUMP ASSEMBLY

DET. QTY PART NO. DESCRIPTION

1	1	147049	BELT, 9425 GATES
2	1	316461	A/C MTG BRKT WLD, STS 2000
3	3	473844	10MM-1.50 X 30 SOC HD CAP SCR
4	3	473798	10MM LOCK WASHER
5	2	483043	3/8 REGULAR FLAT WASHER
6	1	657450	A/C COMPSR,90D PORT TM15/12
7	4	900131	3/8UNC X 1 1/2 HEX BOLT
8	4	914004	3/8UNC HEX STOVER NUT
9	1	657446	A/C HOSE,08-08F90-08F90SV-65"
10	1	657447	A/C HOSE,10-10F90-10F90SV-92"
11	1	316522	A/C MTG BRKT WLD, STS 2002

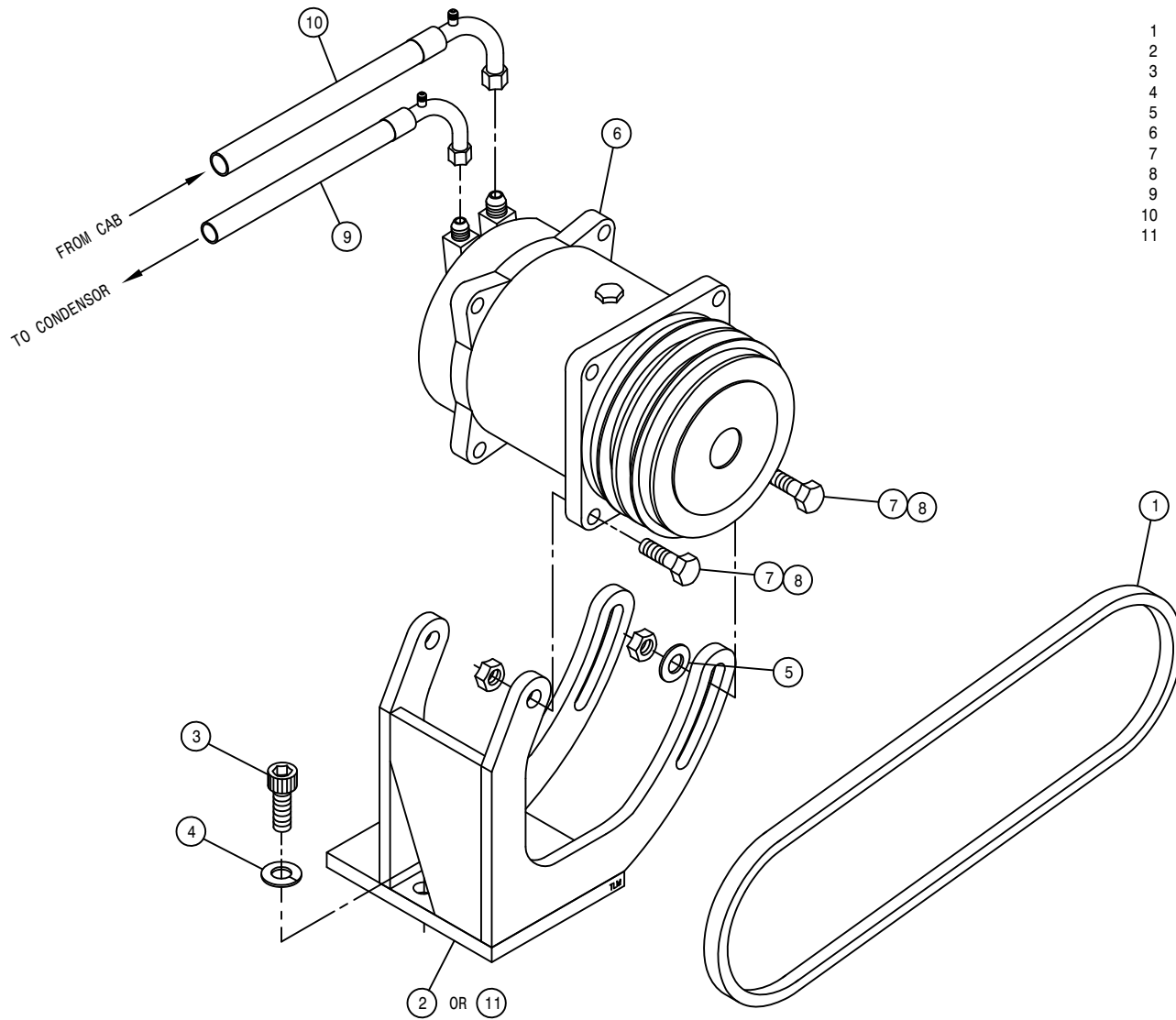

HYDROSTATIC PUMP ASSEMBLY

DET.	QTY	PART NO.	DESCRIPTION
	1	606965	TANDEM PUMP, 606966 & 606969
	2	606966	SUND 75CC PUMP, C/C-MT
	3	606969	SUND 75CC PUMP, C/B-MT
	4	606084	TANDEM PUMP, 606087 & 606987
	5	606087	SAUER GEAR PUMP, 3.87CI GRP3
	6	606987	SUND GEAR PUMP, .128CI GRP3
	7	2	611127 1 1/16MJIC-1 1/16MOR ADPTR
	8	1	614754 .050 ELBOW ASSY, 9/16MOR 90D
	9	1	618115 9/16MJIC-90-3/4MOR LBO
	10	2	618126 9/16MJIC-9/16MOR ADPTR
	11	2	618186 1 5/16MJIC-1 5/16MOR ADPTR
	12	1	618191 1 1/16MJ-90-1 1/16FJ SWIV LBO
	13	1	606074 FLO DIV BG420 20GPM PRI 16FOR
	14	4	618327 3/4MJIC-7/8MOR ADPTR
	15	1	618444 9/16MOR RUN TEE-9/16MJIC
	16	2	618451 3/4FJIC SW RUN TEE-3/4MJIC
	17	1	607550 IN-LINE RELIEF VALVE, 2600 PSI
	18	1	618531 9/16FJIC CAP NUT
	19	1	618178 1 5/16MJIC-90-1 5/16MOR LBO
	20	1	618640 1 5/16MJ-90-1 5/16FJ SWIV LBO
	21	1	618641 1 1/16FJIC-1 5/16MJIC ADPTR
	22	4	618652 1" SPLIT FLANGE KIT
	23	3	618653 1" FLANGE-1 7/16MFOR ADPTR
	24	1	618654 1" FLANGE-90-1 7/16MFOR LBO
	25	4	618655 1 7/16FFOX RUN TEE-1 7/16MFOR
	26	1	618660 1 1/16FJX BRANCH TEE-1 1/16MJ
	27	1	618661 1 5/16FJIC-9/16MJIC ADPTR
	28	4	618676 O-RING FOR 1" SPL FLG 618652
	29	1	606870 O-RING FOR 606865 SUND B-MT
	30	4	900265 1/2UNC X 1 1/2 HEX BOLT
	31	4	920504 1/2 LOCK WASHER
	32	4	920004 1/2 SAE FLAT WASHER
	33	12	618677 O-RING, -16 FACE SEAL .93ID 90D
	34	1	618248 1 1/16MJIC-90-1 1/16MOR LBO
	35	1	618308 1 1/16MJIC-1 5/16MOR ADPTR
	36	1	618471 1 5/8MJIC-1 5/16MOR ADPTR
	37	1	618717 1 5/16FJX BRANCH TEE-1 5/16MJ
	38	2	618680 1 7/8FJIC-1 5/16MJIC ADPTR
	39	1	618681 1 7/8FJ SW RUN TEE-1 7/8MJ
	40	1	618682 1 7/8MOR-1 7/8MJIC ADPTR
	41	1	618683 1 5/8MOR-1 5/8FJIC SWIV ADPTR
	42	1	618684 1 1/16MOR-90-1 1/16FJIC SWIV
	43	1	618279 1 1/16MJIC-90-7/8MOR LBO

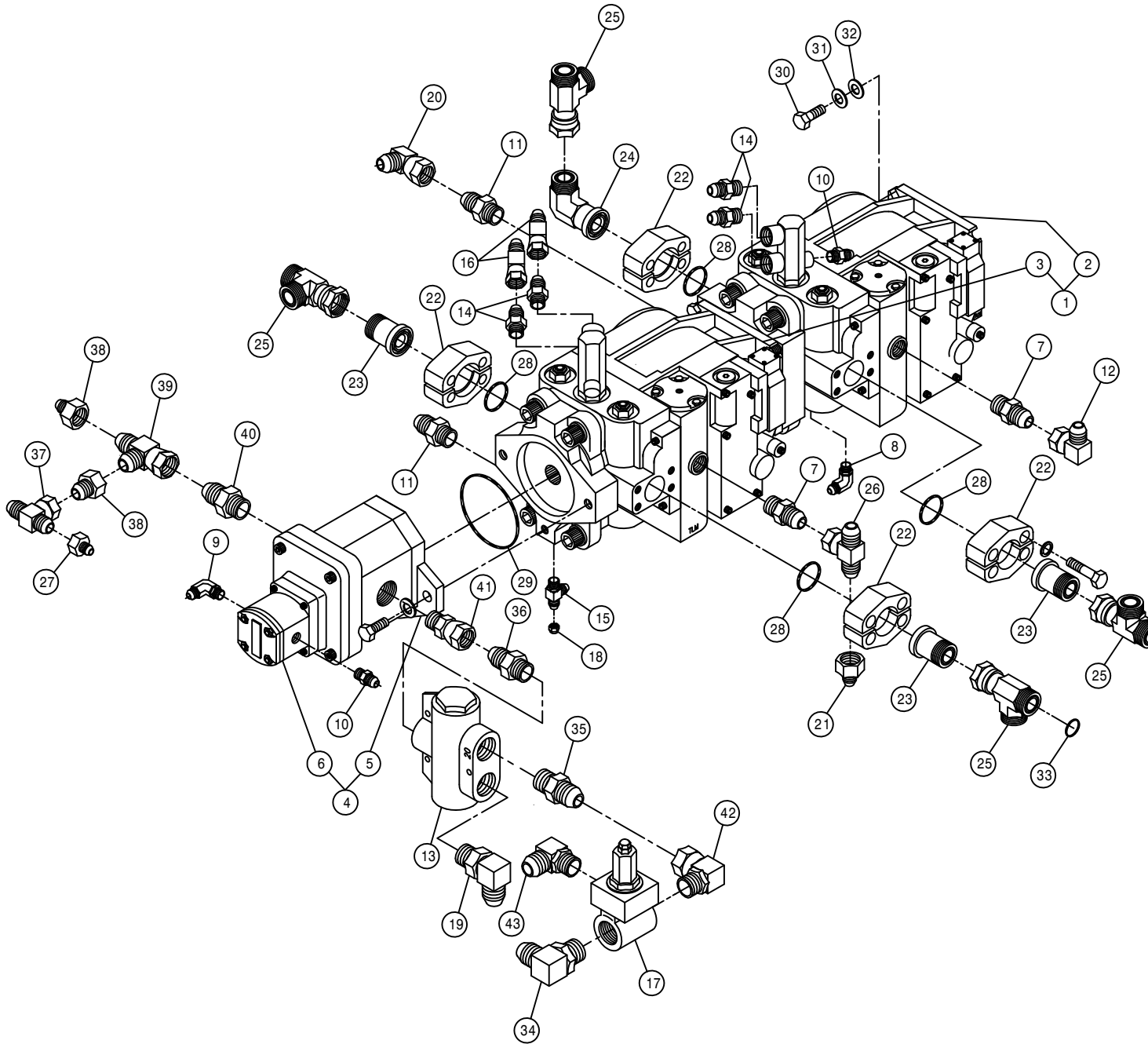

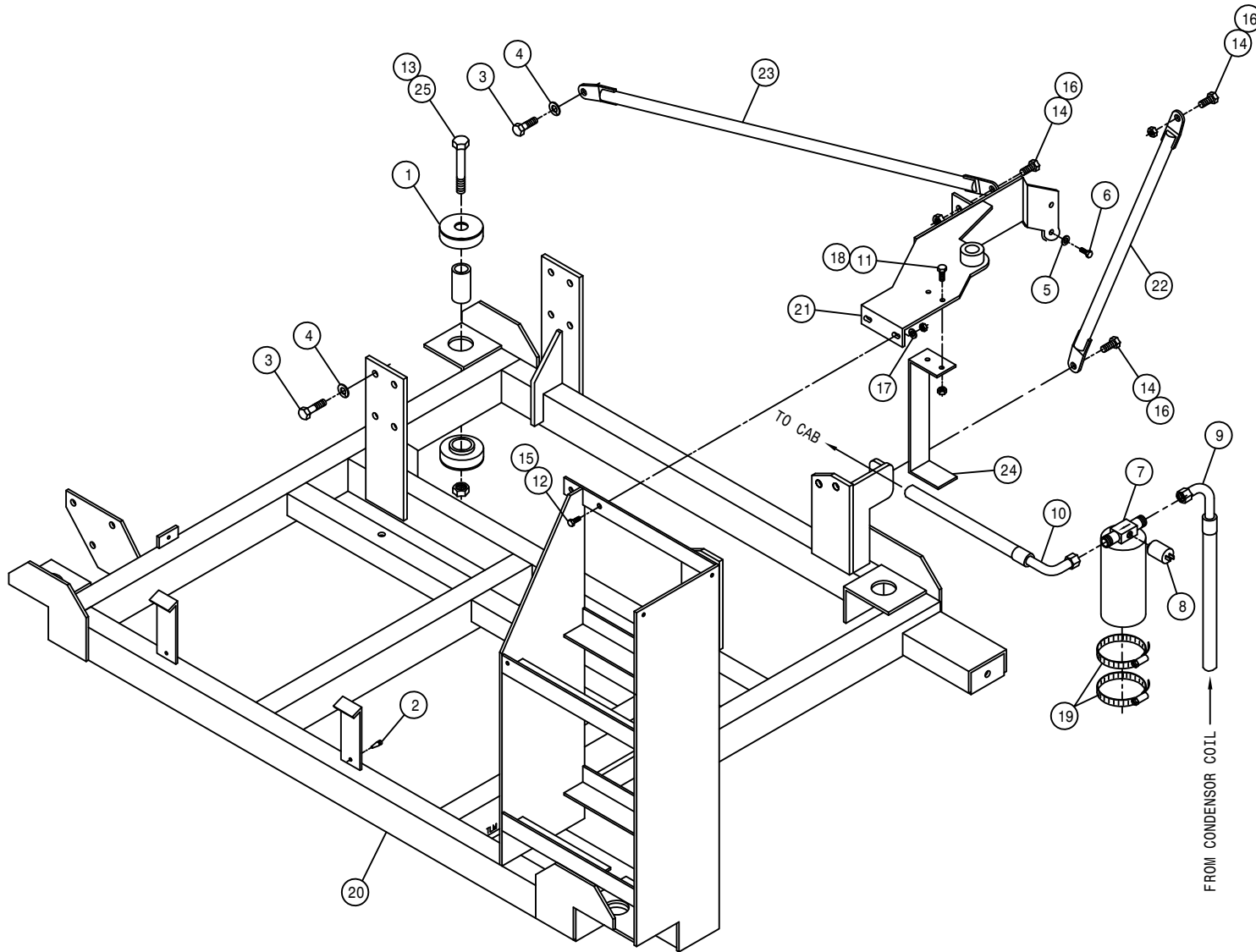

ENGINE SKID ASSEMBLY

DET.	QTY	PART NO.	DESCRIPTION
1	4	311057	RUBBER MT SET,SSB33-1000-4
2	4	470313	GROMMET BUMPER,1/4T X 1/4D MT
3	13	473775	12MM-1.75 X 30MM HEX BOLT
4	13	473784	12MM LOCK WASHER
5	2	473804	8MM LOCK WASHER
6	2	473827	8MM-1.25 X 20MM HEX BOLT
7	1	657421	A/C RECEIVER/DRIER
8	1	657422	A/C BINARY SWITCH
9	1	657443	A/C HOSE,06-06F90-06F90-34"
10	1	657444	A/C HOSE,06-06F90-06F90-115"
11	2	900065	5/16UNC X 1" HEX BOLT
12	2	900129	3/8UNC X 1" HEX BOLT
13	4	914012	3/4UNC HEX STOVER NUT
14	3	900264	1/2UNC X 1 1/4 HEX BOLT
15	2	914004	3/8UNC HEX STOVER NUT
16	3	914008	1/2UNC HEX STOVER NUT
17	2	920002	3/8 SAE FLAT WASHER
18	2	914002	5/16UNC HEX STOVER NUT
19	2	520052	HOSE CLAMP NO 52 STAINLESS
20	1	316380	SKID WLD
21	1	316426	RAD MT PLT WLD
22	1	316433	RH RAD BRACE WLD
23	1	316434	LH RAD BRACE WLD
24	1	316432	A/C DRYER MT
25	4	900408	3/4UNC X 3 1/2 HEX BOLT

AIR CLEANER ASSEMBLY

DET.	QTY	PART NO.	DESCRIPTION
1	1	314971	AIR CLEANER HOOD FOR 314970
2	1	311502	AIR CLEANER, 14"
3	2	311503	AIR CLEANER MT BAND FOR 311502
4	1	311504	AIR FILTER FOR 311502
5	1	311505	4.00 90 DEG COBRA ELBOW,RUBBER
6	1	311506	5.50-4.00 ID REDUCER BUSHING
7	1	311507	4.00" 45DEG ELBOW, RUBBER
8	1	311508	5.50" 45DEG ELBOW, RUBBER
9	1	314901	FILTER MINDER AIR RESTRICT GA
10	1	314986	AIR CLEANER HOOD EXTEN,5"X8"LG
11	1	316068	4" X 6.00" AIR INTAKE TUBE
12	1	316344	4" X 4.00" AIR INTAKE TUBE 98
13	1	470260	MUFFLER CLAMP, 5.00
14	2	473775	12MM-1.75 X 30MM HEX BOLT
15	2	473784	12MM LOCK WASHER
16	2	473798	10MM LOCK WASHER
17	2	473818	10MM-1.50 X 40MM HEX BOLT
18	2	900072	5/16UNC X 3" HEX BOLT
19	2	473843	12MM FLAT WASHER
20	1	520117	CUSH HOSE CLAMP 5/8D X 1/2W
21	4	520134	4.31/4.59 T-BOLT HOSE CLAMP SS
22	2	520144	5.94/6.21 T-BOLT HOSE CLAMP SS
23	1	601474	HOSE, 1/4 X 26 AIR
24	1	311512	7.00-4.75 ID REDU BOOT, RUBBER
25	1	711036	1/8MNPT-1/4 NYL TUBE FTG
26	1	711039	1/8MNPT-1/4 NYL TUBE LBO
27	1	900000	1/4UNC X 1/2 HEX BOLT
28	2	900002	1/4UNC X 3/4 HEX BOLT
29	5	900129	3/8UNC X 1" HEX BOLT
30	3	914000	1/4UNC HEX STOVER NUT
31	2	914002	5/16UNC HEX STOVER NUT
32	5	914004	3/8UNC HEX STOVER NUT
33	8	920002	3/8 SAE FLAT WASHER
34	1	316464	AIR CLEANER MT WLD
35	1	316468	DIPSTICK MTG BRKT
36	1	316469	FILTER MINDER GAUGE MT
37	1	601478	HOSE, 1/4 X 175 AIR
38	1	291703	BATT CABLE,BLK 12" 6GA 3/8-3/8
39	1	316277	AIR COMPRESSOR GOVERNOR KIT

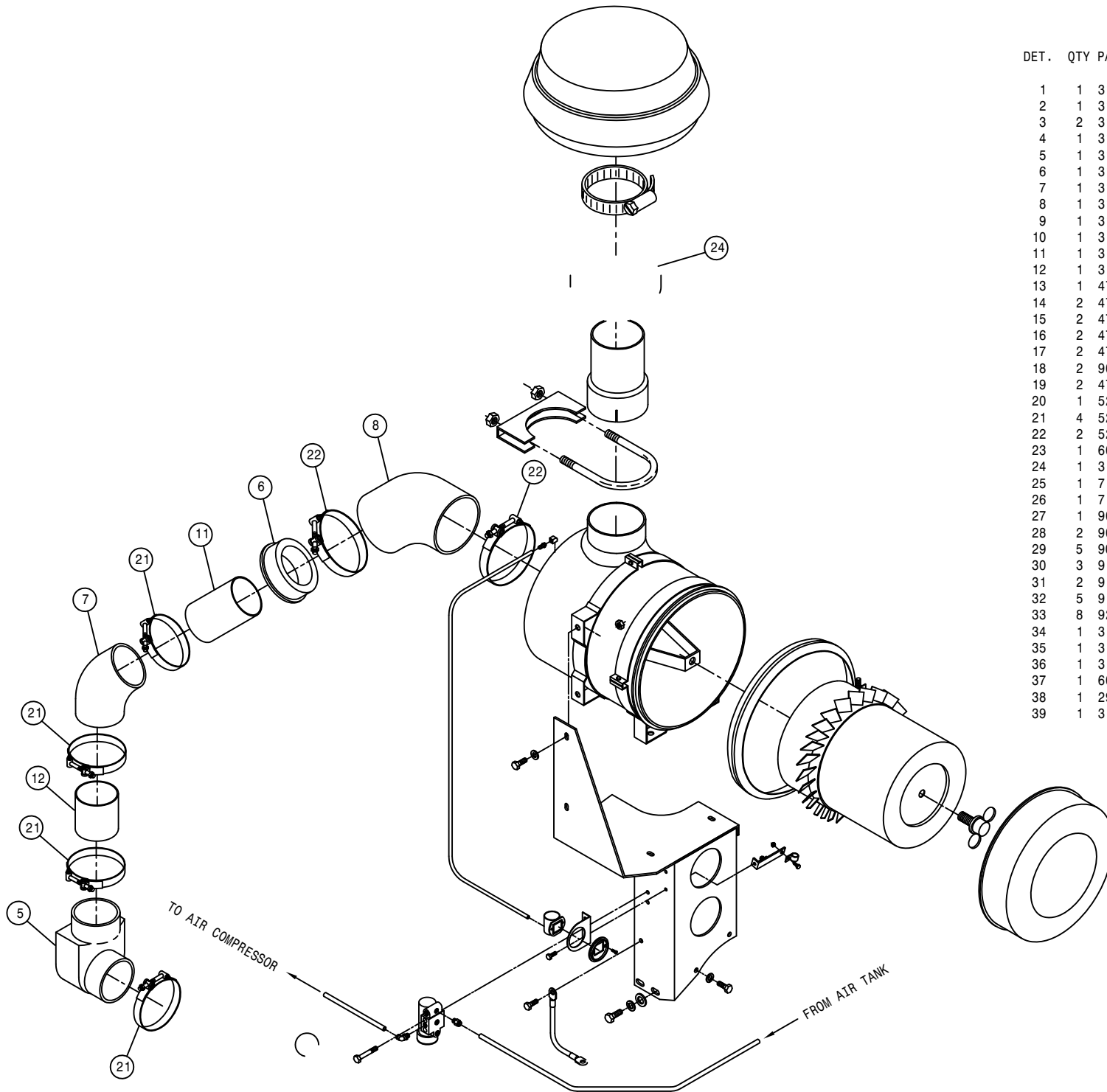

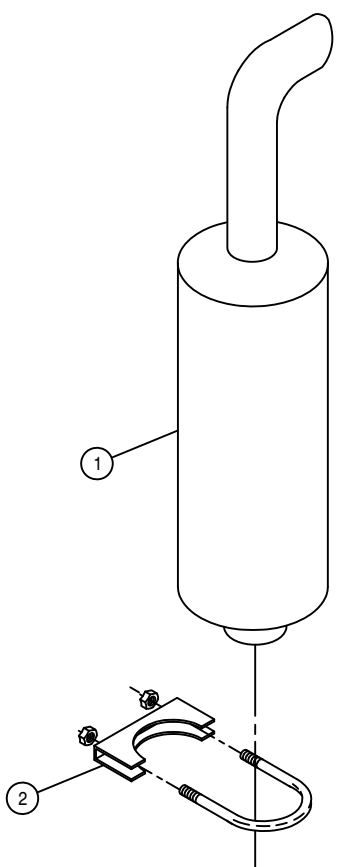

MUFFLER ASSEMBLY

DET.	QTY	PART NO.	DESCRIPTION
1	1	316366	MUFFLER, STS12
2	1	470160	MUFFLER CLAMP 3.00 IN

RADIATOR AND OIL COOLER ASSEMBLY

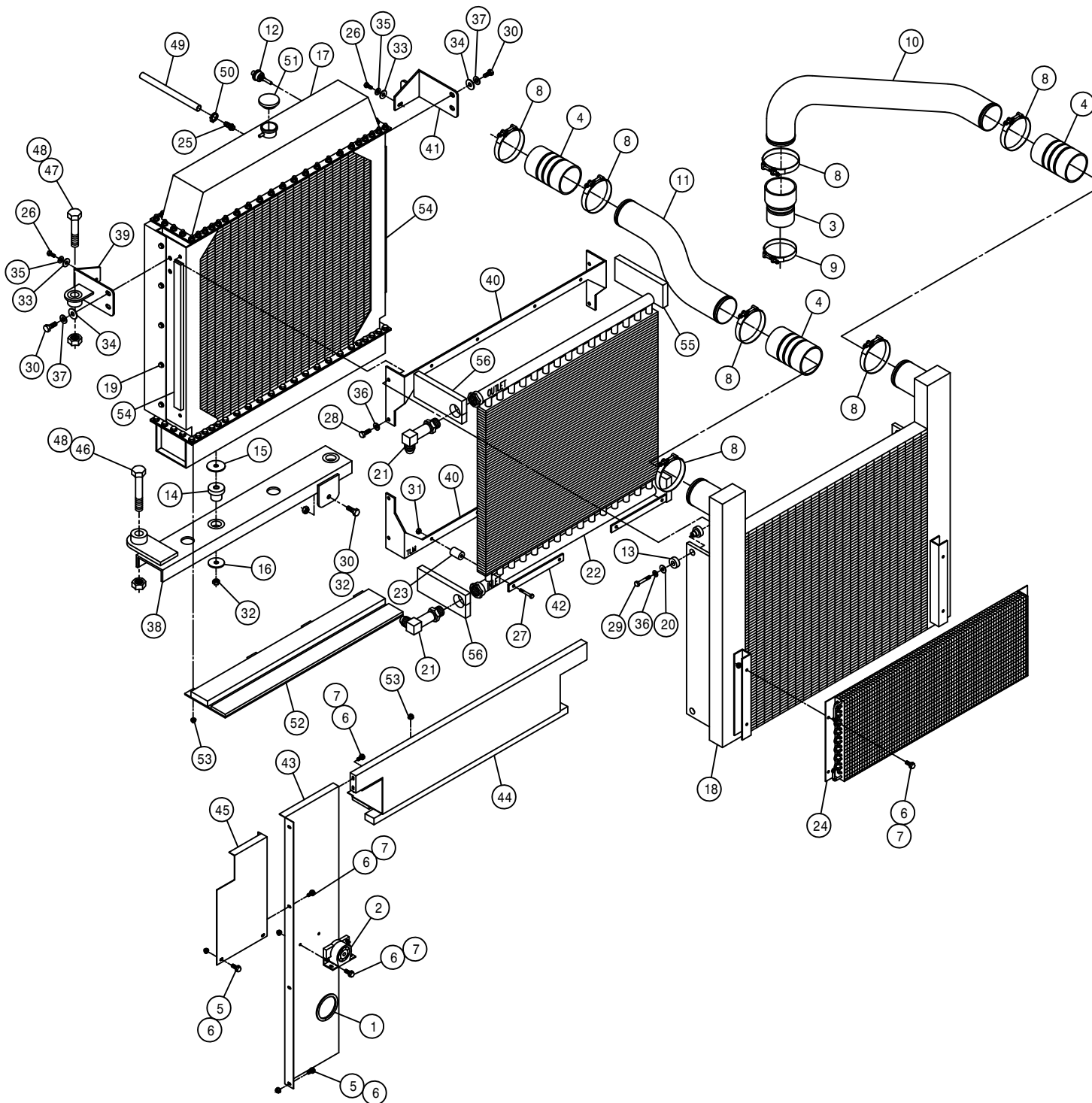

DET.	QTY	PART NO.	DESCRIPTION
1	1	193012	QUICKEDGE TRIM .135 TO .250
2	1	291759	BACK-UP WARNING BEEPER, 112DB
3	1	311500	3.00-3.50 CAC HOSE, AIR INTAKE
4	3	311501	3.50 CAC HOSE, AIR INTAKE
5	4	470118	1/4UNC X 3/4 FLANGE HEX BOLT
6	14	470121	1/4UNC HEX FLANGE LOCK NUT
7	10	470122	1/4UNC X 1/2 FLANGE HEX BOLT
8	7	520145	356 T-BOLT HOSE CLAMP SS
9	1	520146	306 T-BOLT HOSE CLAMP SS
10	1	316459	RIGHT CHARGE AIR COOLER PIPE
11	1	316460	LEFT CHARGE AIR COOLER PIPE
12	1	291714	WATER LEVEL SENSOR
13	4	311056	RUBBER MOUNT SET,2-PC CB 2320
14	2	311060	RUBBER MOUNT,1-PC CB-1122-2
15	2	311061	HEAD WASHER FOR 311060
16	2	311062	TAIL WASHER FOR 311060
17	1	316364	RADIATOR, STS12 2000
18	1	316365	CHARGE AIR COOLER, STS12 2000
19	10	470319	3/8UNC X 1/2 FLANGE HEX BOLT
20	4	483043	3/8 REGULAR FLAT WASHER
21	2	618463	1 5/16MJIC-90-1 5/16MOR XL LBO
22	1	618800	OIL COOLER STS12 2000
23	8	618801	MOUNTING KIT FOR 618800 COOLER
24	1	657434	A/C CONDENSER COIL 21-0302
25	1	783304	1/4 NPT X 3/8 HOSE BARB, BRS
26	2	900064	5/16UNC X 3/4 HEX BOLT
27	8	900071	5/16UNC X 2 3/4 HEX BOLT
28	4	900128	3/8UNC X 3/4 HEX BOLT
29	4	900133	3/8UNC X 2" HEX BOLT
30	5	900264	1/2UNC X 1 1/4 HEX BOLT
31	8	914002	5/16UNC HEX STOVER NUT
32	3	914008	1/2UNC HEX STOVER NUT
33	2	920001	5/16 SAE FLAT WASHER
34	4	920004	1/2 SAE FLAT WASHER
35	2	920501	5/16 LOCK WASHER
36	8	920502	3/8 LOCK WASHER
37	4	920504	1/2 LOCK WASHER
38	1	316439	RAD MT WLD
39	1	316447	UPPER LH RAD MT WLD
40	2	316452	RAD TO OIL COOLER MT
41	1	316446	UPPER RH RAD MT WLD 2000
42	4	316453	RAD TO OIL COOLER KEEPER
43	1	316457	BATTERY BOX FILLER PANEL
44	1	316487	UPR RADIATOR FILLER PANEL ASSY
45	1	316458	UPPER BATTERY BOX FILLER
46	1	900540	1" UNC X 7" HEX BOLT
47	1	900541	1" UNC X 3 3/4" HEX BOLT
48	2	914016	1" UNC HEX STOVER NUT
49	1	601472	HOSE, 3/8 X 24 HEATER
50	1	520069	HOSE CLAMP NO 6 STAINLESS
51	1	316377	RAD CAP, 10LB 10237
52	1	316490	LWR RADIATOR FILLER PANEL ASSY
53	8	470113	5/16UNC HEX FLANGE LOCK NUT
54	2	316493	SIDE FOAM,RAD/CAC
55	2	316494	RH UPR/LWR FOAM,OIL CLR/RAD 00
56	2	316495	LH UPR/LWR FOAM,OIL CLR/RAD 00

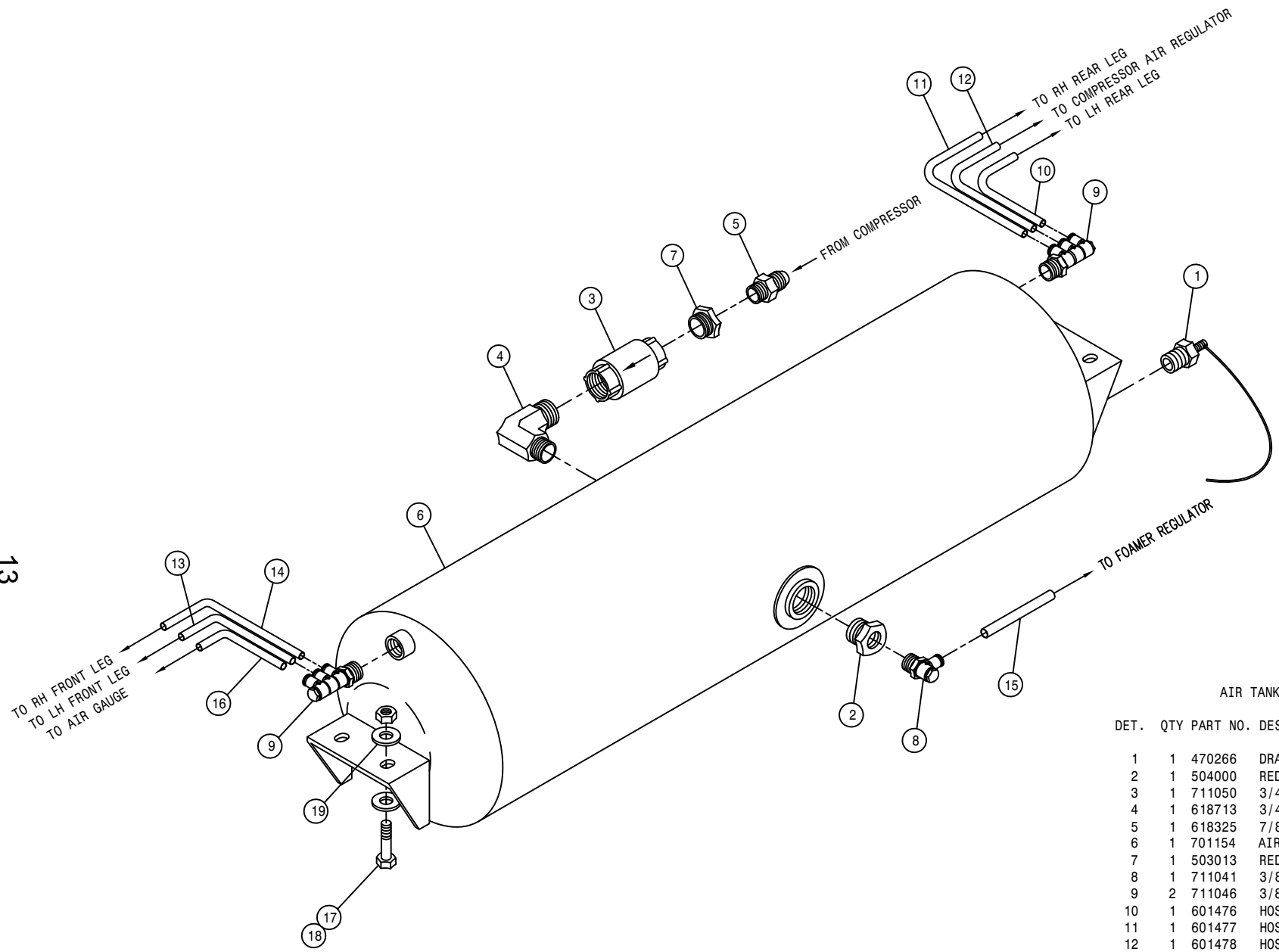

AIR TANK ASSEMBLY

DET.	QTY	PART NO.	DESCRIPTION
1	1	470266	DRAIN VALVE KIT, 1/4NPT
2	1	504000	RED BUSH 3/4 TO 3/8
3	1	711050	3/4"FNPT CHECK VALVE S.S.
4	1	618713	3/4MNPT-90-3/4MNPT LBO
5	1	618325	7/8MJIC-1/2MNPT ADPTR
6	1	701154	AIR TANK
7	1	503013	RED BUSH 3/4MNPT-1/2FNPT,STEEL
8	1	711041	3/8MNPT-3/8 NYL TUBE LBO
9	2	711046	3/8MNPT-1/4 NYL TUBE TRPL LBO
10	1	601476	HOSE, 1/4 X 120 AIR
11	1	601477	HOSE, 1/4 X 160 AIR
12	1	601478	HOSE, 1/4 X 175 AIR
13	1	601479	HOSE, 1/4 X 196 AIR
14	1	601480	HOSE, 1/4 X 230 AIR
15	1	601482	HOSE, 3/8 X 80 AIR
16	1	601486	HOSE, 1/4 X 215 AIR
17	4	900130	3/8UNC X 1 1/4 HEX BOLT
18	4	914004	3/8UNC HEX STOVER NUT
19	8	920002	3/8 SAE FLAT WASHER

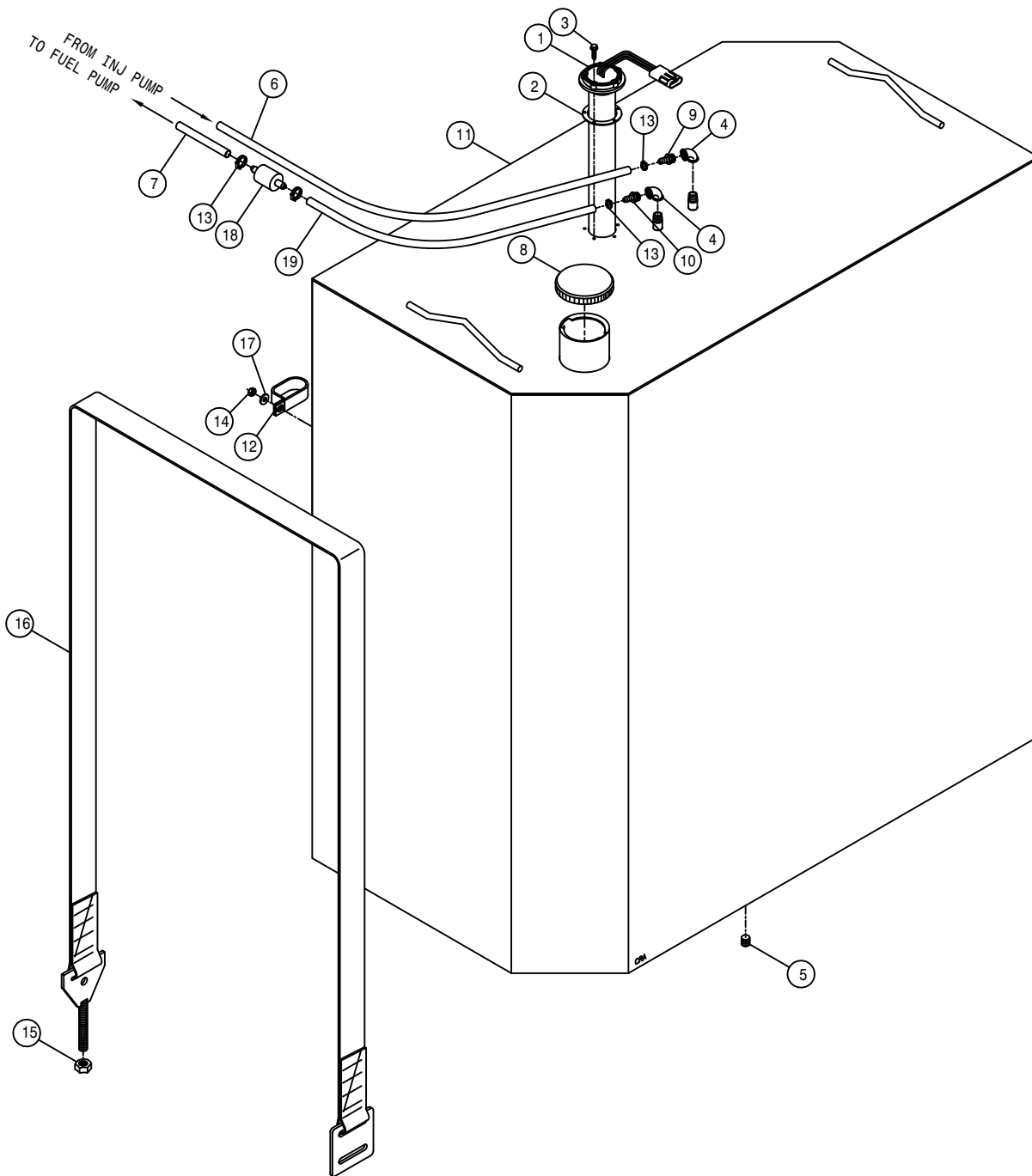

FUEL TANK ASSEMBLY

DET. QTY PART NO. DESCRIPTION

1	1	291788	FUEL SENDER
2	1	291789	GASKET FOR FUEL SENDER 291788
3	5	472347	#10 X 1 1/4 SELF DRILL/TAP SCR
4	2	501451	BLK PIPE EL 90DEG .25NPT
5	1	503703	PIPE PLUG .50NPT SKT HD
6	1	601300	HOSE, 5/16 X 60 FUEL LINE
7	1	601550	HOSE, 3/8 X 22 FUEL LINE
8	1	761202	FUEL TANK CAP,3" VENTED,ZINCPL
9	1	783303	1/4 NPT X 5/16 HOSE BARB, BRS
10	1	783304	1/4 NPT X 3/8 HOSE BARB, BRS
11	1	760251	FUEL TANK WLD
12	1	520116	CUSH HOSE CLAMP 1IN DBL TUBE
13	4	520120	HOSE CLAMP NO 4 STAINLESS
14	1	914000	1/4UNC HEX STOVER NUT
15	2	914008	1/2UNC HEX STOVER NUT
16	2	316473	FUEL TANK HOLD-DOWN STRAP ASSY
17	1	920000	1/4 SAE FLAT WASHER
18	1	316281	FUEL STRAINER, IN-LINE, DIESEL
19	1	601551	HOSE, 3/8 X 38 FUEL LINE

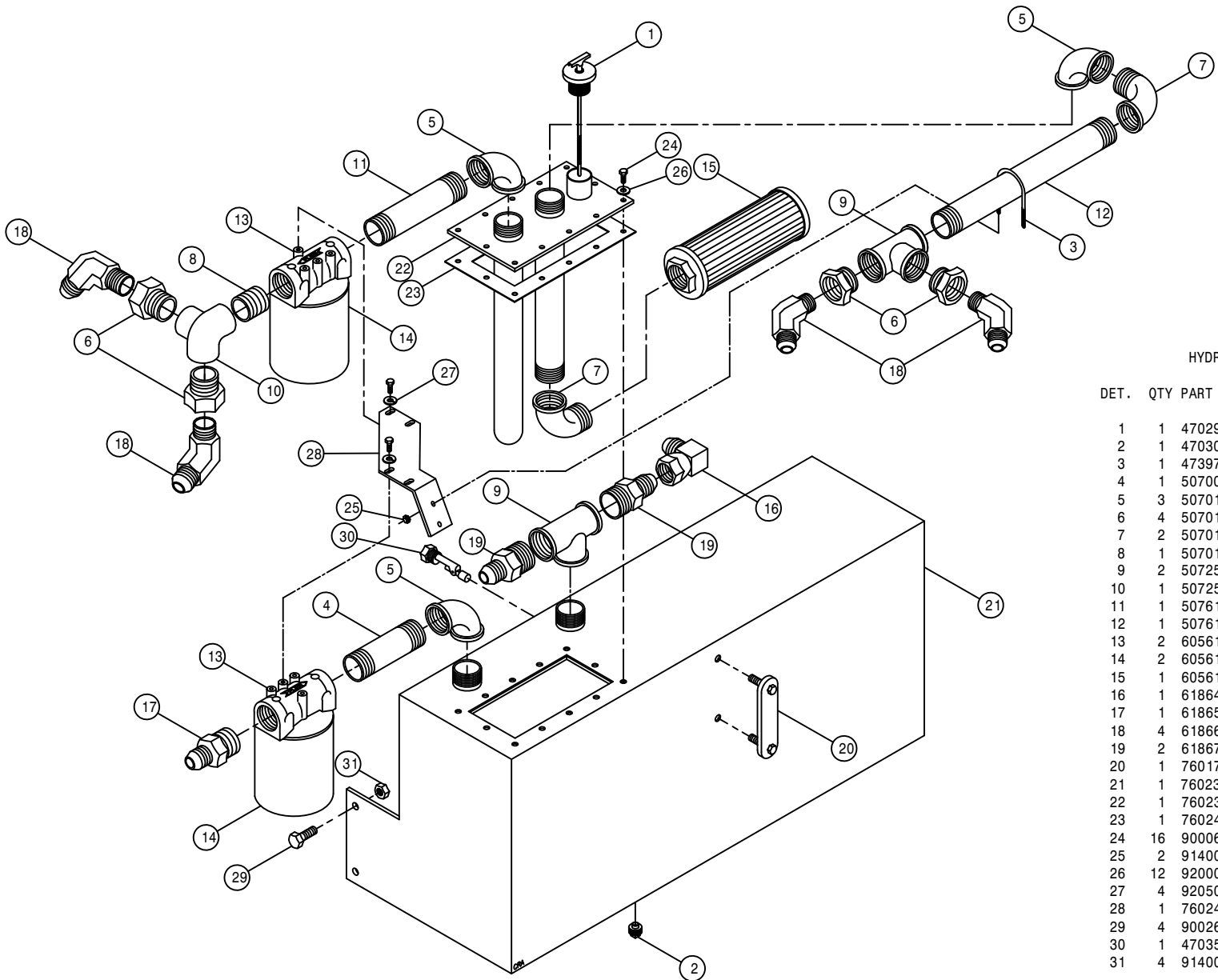

HYDRAULIC TANK ASSEMBLY

DET.	QTY	PART NO.	DESCRIPTION
1	1	470293	DIPSTICK, VENTED
2	1	470308	1/2MNPT DRAIN PLUG,AL HD,MAG
3	1	473971	1/4UNC-2"ID-3"RD U-BOLT
4	1	507009	BLK PIPE NIPPLE 1.50NPT-6.00
5	3	507014	BLK PIPE EL 90DEG 1.50NPT
6	4	507015	RED BUSH 1.50NPT - 1.25FNPT
7	2	507018	BLK PIPE ST EL 90DEG 1.50NPT
8	1	507019	CLOSE NIPPLE 1.50NPT
9	2	507250	BLK PIPE TEE 1.50NPT
10	1	507252	SIDE OUTLET EL 90DEG 1.50NPT
11	1	507610	BLK PIPE NIPPLE 1.50NPT-8.00
12	1	507617	BLK PIPE NIPPLE 1.50NPT-16.00
13	2	605611	FILTER HEAD, 1 1/2FNPTF ZINGA
14	2	605612	FILTER, 10 MICRON
15	1	605613	TANK FILTER,100 MESH,1 1/2FNPT
16	1	618640	1 5/16MJ-90-1 5/16FJ SWIV LBO
17	1	618656	1 5/8MJIC-1 1/2MNPT ADPTR
18	4	618667	1 5/16MJIC-45-1 1/4MNPT LBO
19	2	618672	1 5/16MJIC-1 1/2MNPT ADPTR
20	1	760177	SIGHT GAUGE W/TEMP, HYD TANK
21	1	760231	HYD TANK WLD STS12
22	1	760239	RECEIVER PLATE WLD STS12
23	1	760243	GASKET, RECEIVER PLATE STS12
24	16	900064	5/16UNC X 3/4 HEX BOLT
25	2	914000	1/4UNC HEX STOVER NUT
26	12	920001	5/16 SAE FLAT WASHER
27	4	920501	5/16 LOCK WASHER
28	1	760245	HYD FILTER KEEPER
29	4	900264	1/2UNC X 1 1/4 HEX BOLT
30	1	470350	LIQUID LEVEL SWITCH,1/2MNPT 02
31	4	914008	1/2UNC HEX STOVER NUT

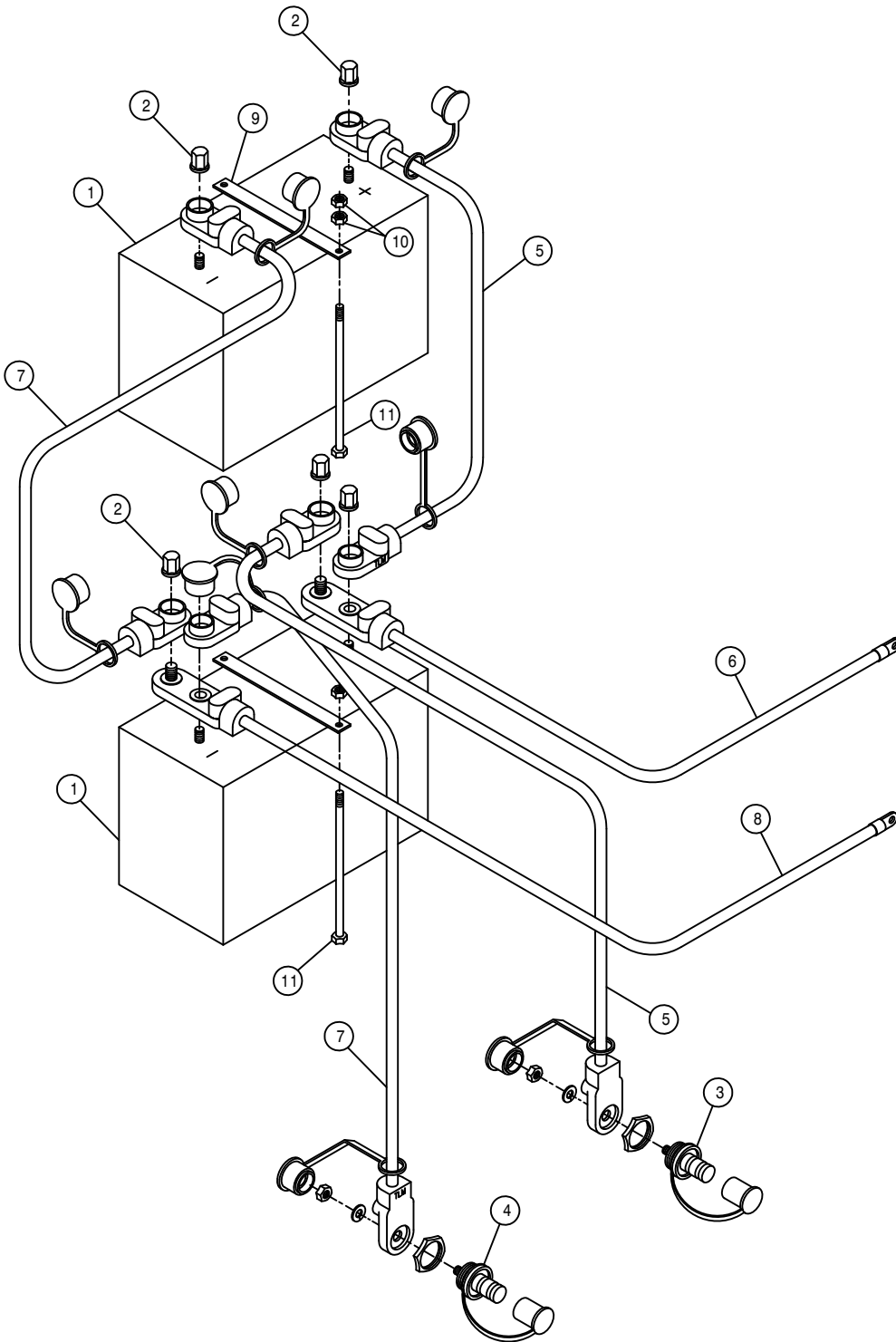

BATTERY ASSEMBLY

DET. QTY PART NO. DESCRIPTION

1	2	291196	BATTERY, 12V 950CCA, SS STUD
2	6	291205	BATTERY NUT, 3/8-16 SS CLSD CAP
3	1	291680	POSITIVE JUMPER STUD, RED
4	1	291681	NEGATIVE JUMPER STUD, BLACK
5	2	291705	BATT CABLE, RED 26" 2/0 3/8-3/8
6	1	291706	BATT CABLE, RED 70" 2/0 3/8-3/8
7	2	291707	BATT CABLE, BLK 26" 2/0 3/8-3/8
8	1	291708	BATT CABLE, BLK 73" 2/0 3/8-3/8
9	2	316470	BATTERY TIE-DOWN
10	8	910004	3/8UNC HEX NUT
11	4	900150	3/8UNC X 9 1/2 HEX BOLT

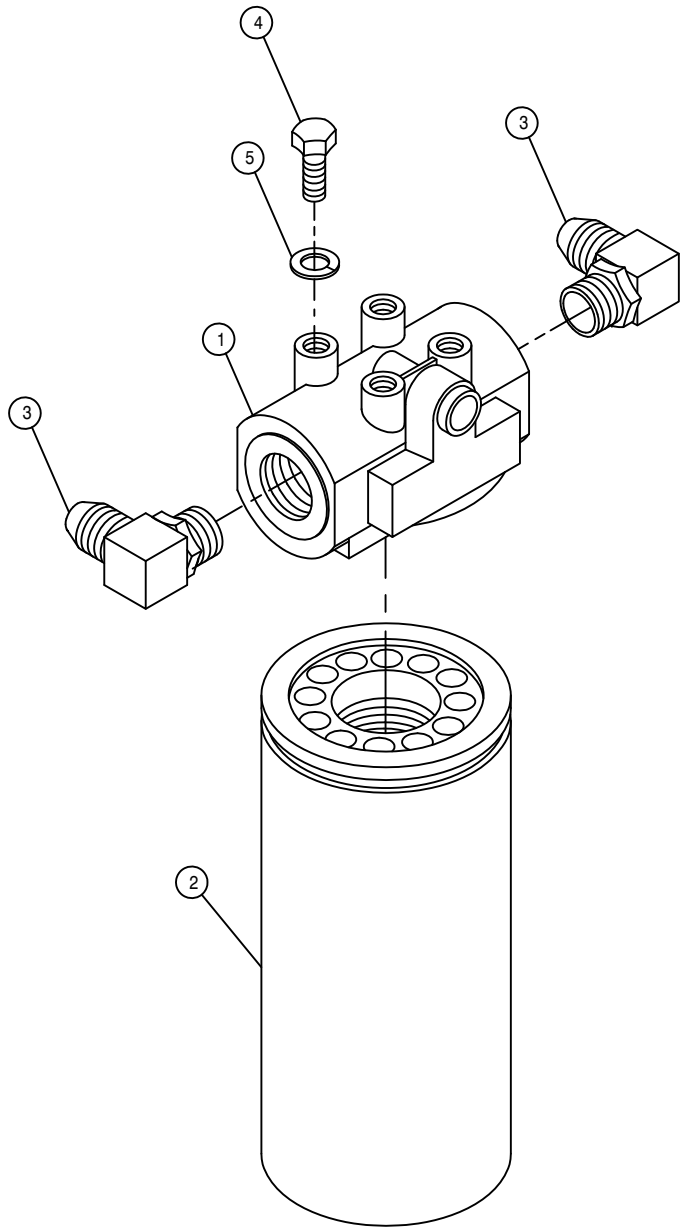

HI-PRESS FILTER ASSEMBLY

DET. QTY PART NO. DESCRIPTION

1	1	605608	HYD FILTER HEAD, DONALDSON
2	1	605609	HYD FILTER ELEMENT, DONALDSON
3	2	618474	3/4MJIC-90-1 1/16MOR LBO
4	4	900128	3/8UNC X 3/4 HEX BOLT
5	4	920502	3/8 LOCK WASHER

LADDER AND BRAKE VALVE ASSEMBLY

DET.	QTY	PART NO.	DESCRIPTION
1	1	606011	LADDER/BRKWAY VLV W/TOWER ASSY
2	1	606013	BRAKE VLV W/TOWER ASSY
3	1	618126	9/16MJIC-9/16MOR ADPTR
4	3	618119	9/16MJIC-90-9/16MOR LBO
5	1	618486	9/16FJIC SW RUN TEE-9/16MJIC
6	1	618618	9/16MJIC-90-9/16FJIC SWIV LBO
7	1	618444	9/16MOR RUN TEE-9/16MJIC
8	2	900012	1/4UNC X 3 1/2 HEX BOLT
9	2	470121	1/4UNC HEX FLANGE LOCK NUT
10	1	342824	TRD ADJ HARNESS CONNECTOR BRKT
11	1	342826	SOLE VLV SPACER
12	2	914000	1/4UNC HEX STOVER NUT
13	2	610185	9/16MOR PLUG

*NOTE: ITEMS 9 & 10 ARE USED WITH THE TREAD ADJUST OPTION.

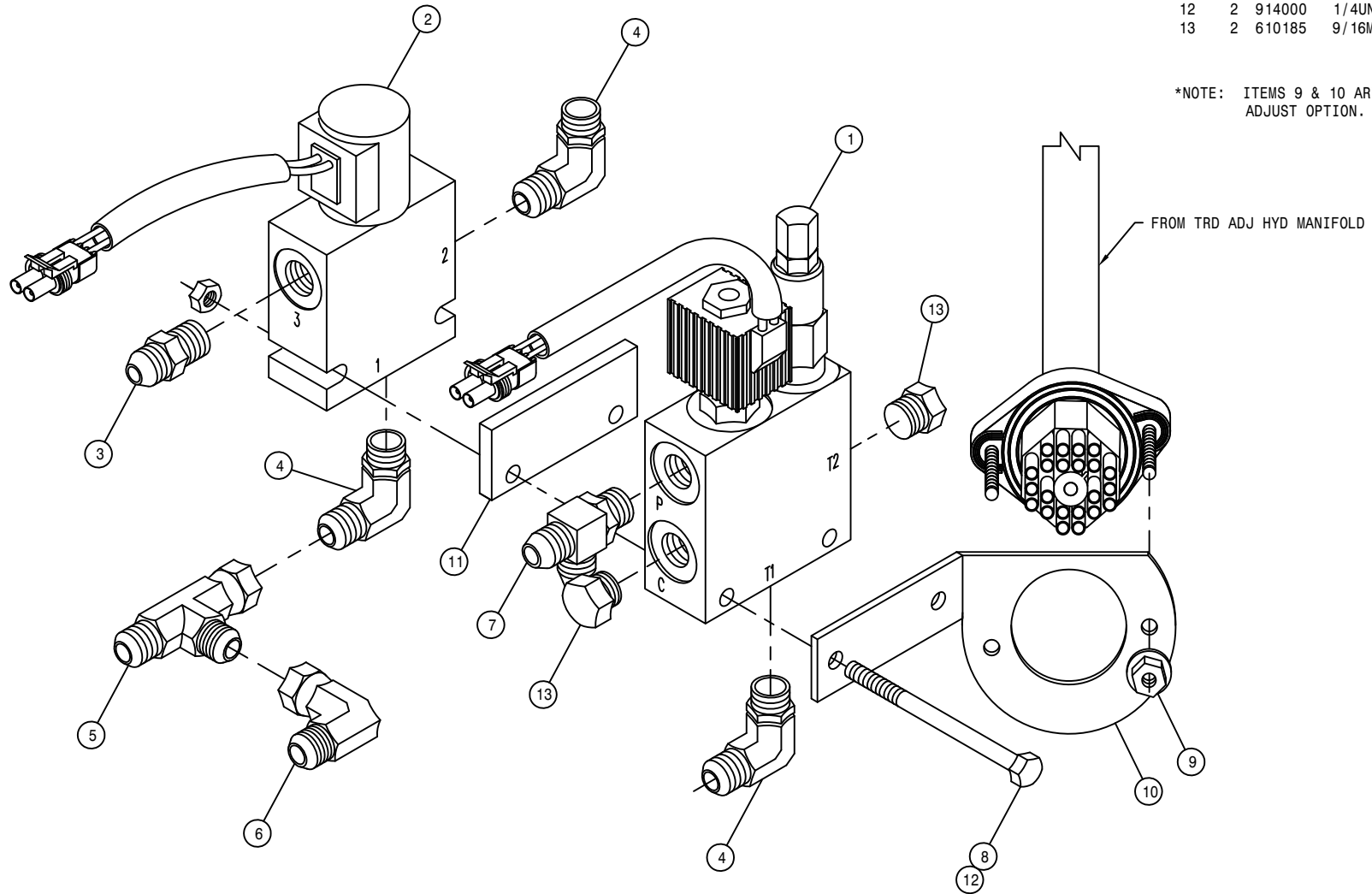

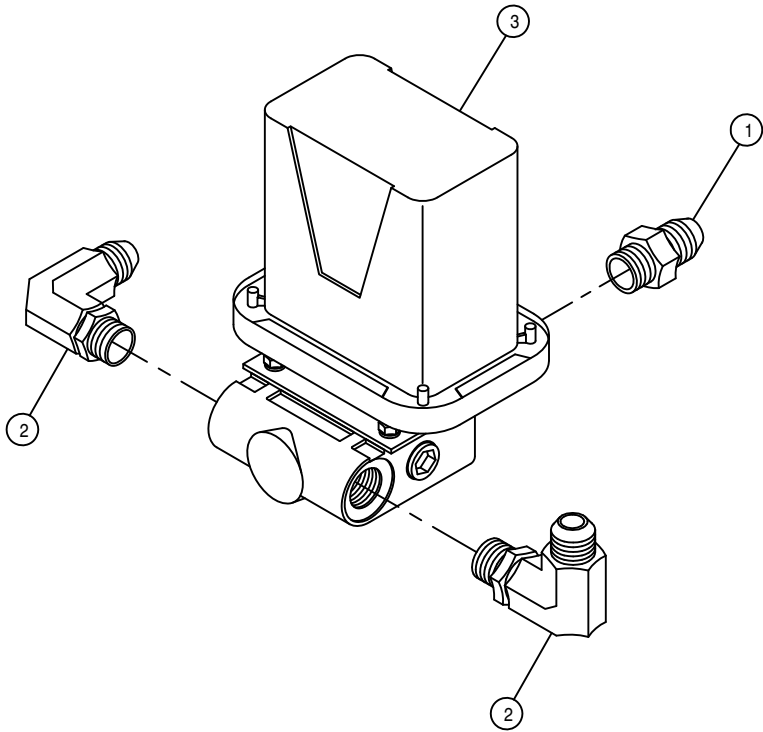

RAVEN HYD CONTROL VALVE ASSEMBLY

DET. QTY PART NO. DESCRIPTION

1	1	611127	1 1/16MJIC-1 1/16MOR ADPTR
2	2	618248	1 1/16MJIC-90-1 1/16MOR LBO
3	1	690666	VALVE HYD CTRL,30GPM RAVEN

RIGHT FRONT OUTER LEG ASSEMBLY

DET. QTY PART NO. DESCRIPTION

DET.	QTY	PART NO.	DESCRIPTION
1	2	121029	JOURNAL BRG, 1.00 ID X 1.00 LG
2	1	125050	BRG CONE, 1.00 ID W/FACE SEAL
3	1	125051	BRG CUP FOR 125050
4	1	125052	BRG CONE, 2.687 ID W/FACE SEAL
5	1	125053	BRG CUP FOR 125052
6	2	311058	RUBBER SPRING
7	1	311066	AIRIDE SPRING, STS12
8	1	311067	HEIGHT CONTROL AIR VALVE
9	1	311069	7.00 LEVER, CTRL AIR VLV 311067
10	1	311070	LEVER SCREW, CTRL AIR VLV311067
11	1	359005	OUTER LEG WLD, 72" STS12
12	1	470305	HOSE CLAMP, 4-HOLE
13	1	471005	1/4 28 X 1/2 GREASE ZERK
14	1	473975	ROD END, 1"-12 RH MALE
15	1	621050	STEERING CYL ASSY STS12
16	2	629536	RETAINING RING, 6.00 INT SPIRAL
17	2	711036	1/8MNPT-1/4 NYL TUBE FTG
18	1	711040	1/4MNPT-1/4 NYL TUBE LBO
19	1	749322	STEERING TUBE CLAMP & BOLT ASSY
20	2	900006	1/4UNC X 1 3/4 HEX BOLT
21	16	900129	3/8UNC X 1" HEX BOLT
22	2	900138	3/8UNC X 3 1/2 HEX BOLT
23	4	900265	1/2UNC X 1 1/2 HEX BOLT
24	8	900267	1/2UNC X 2" HEX BOLT
25	4	900269	1/2UNC X 2 3/4 HEX BOLT
26	1	900343	5/8UNC X 4 1/2 HEX BOLT
27	2	900352P	5/8UNC X 2 1/4 HEX BOLT
28	1	359085	STEERING ARM BOLT, 1"-8THD STS
29	1	910008	1/2UNC HEX NUT
30	1	910013	3/4UNF HEX NUT
31	1	910021	1"-14 SLOT JAM NUT
32	2	914000	1/4UNC HEX STOVER NUT
33	2	914004	3/8UNC HEX STOVER NUT
34	12	914008	1/2UNC HEX STOVER NUT
35	1	914010	5/8UNC HEX STOVER NUT
36	1	910020	1" UNC HEX SLOTTED NUT
37	1	920008	1" SAE FLAT WASHER
38	16	920502	3/8 LOCK WASHER
39	5	920504	1/2 LOCK WASHER
40	1	920506	3/4 LOCK WASHER
41	2	359084	WASH, 14GA X 4.75ID X 5.8750D
42	1	359057	RH AIR BAG LOWER PLT WLD
43	1	359052	AIR BAG TOWER TOP MT WLD
44	2	359077	TOWER SHAFT WLD
45	1	359082	STEERING ARM BRG SPACER
46	2	121100	LEG SLEEVE BEARING, ORKOT
47	1	359070	RH STEERING ARM WLD
48	1	359049	RH LEG AIR VALVE MT
49	1	359051	LWR AIR VALVE ARM MT
50	1	359081	UPPER LEG HOSE MT PLT
51	1	342719	TRD ADJ BRONZE BEARING, TAPPED
52	2	121105	LEG TOWER SLIDE BEARING, ORKOT
53	1	359094	HYD TUBE CLAMP KEEPER, 5.75
54	1	359095	LEG HEIGHT CTRL LINKAGE, STS12
55	1	359068	UPPER TRUNION MT PLT WLD
56	1	601473	HOSE, 1/4 X 22 AIR
57	1	601480	HOSE, 1/4 X 230 AIR
58	1	470310	SIDEWINDER SLEEVE, 13.50 X 45"
59	1	471021	GREASE ZERK 1/8 NPT STRAIGHT
60	3	342917	TREAD ADJ PLATE, STEEL STS10
61	2	914010P	5/8UNC HEX STOVER NUT
62	1	470117	COTTER PIN 3/16 1 3/4 SQ CUT

*NOTE: FOR TREAD ADJUST OPTION REPLACE ITEM 60 WITH THREE OF ITEM 51.

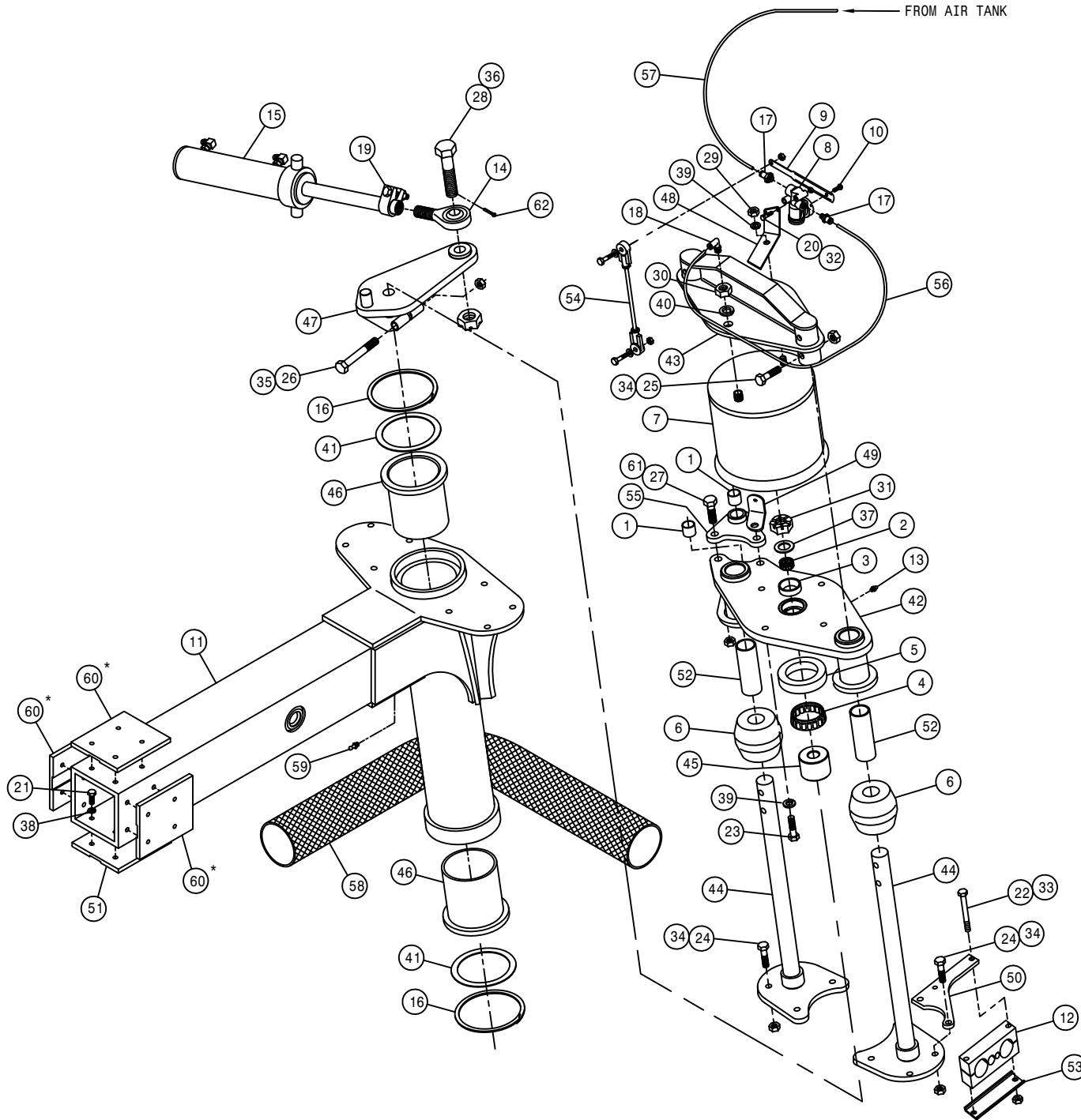

RIGHT FRONT INNER LEG ASSEMBLY

DET. QTY PART NO. DESCRIPTION

1	1	359004	INNER LEG WLD, 72" STS12
2	1	470117	COTTER PIN 3/16 1 3/4 SQ CUT
3	1	470305	HOSE CLAMP, 4-HOLE
4	2	473838	20MM-1.5 X 40MM HEX BOLT 8.8
5	2	473839	20MM FLAT WASHER
6	17	473840	16MM-2.00 X 40MM HEX BOLT 8.8
7	17	473841	16MM LOCK WASHER
8	1	606978	SUND HYD MOTOR
9	1	610711	TORQ HUB, 22:1 CW12
10	2	618652	1" SPLIT FLANGE KIT
11	2	618676	O-RING FOR 1" SPL FLG 618652
12	10	824055	22MM-1.50 FLANGED WHEEL NUT
13	2	900138	3/8UNC X 3 1/2 HEX BOLT
14	4	900264	1/2UNC X 1 1/4 HEX BOLT
15	4	900265	1/2UNC X 1 1/2 HEX BOLT
16	2	914004	3/8UNC HEX STOVER NUT
17	8	914008	1/2UNC HEX STOVER NUT
18	1	359105	RH WHL MTR SHIELD, STS10
19	2	359102	WHL MTR SHIELD BRACE
20	1	359096	RH LWR LEG HYD HOSE MT WLD
21	1	359094	HYD TUBE CLAMP KEEPER, 5.75
22	1	470312	SIDEWINDER SLEEVE, 14.00 X 68"
23	1	606018	O-RING, WHL MTR 606978/606981
24	1	618327	3/4MJIC-7/8MOR ADPTR

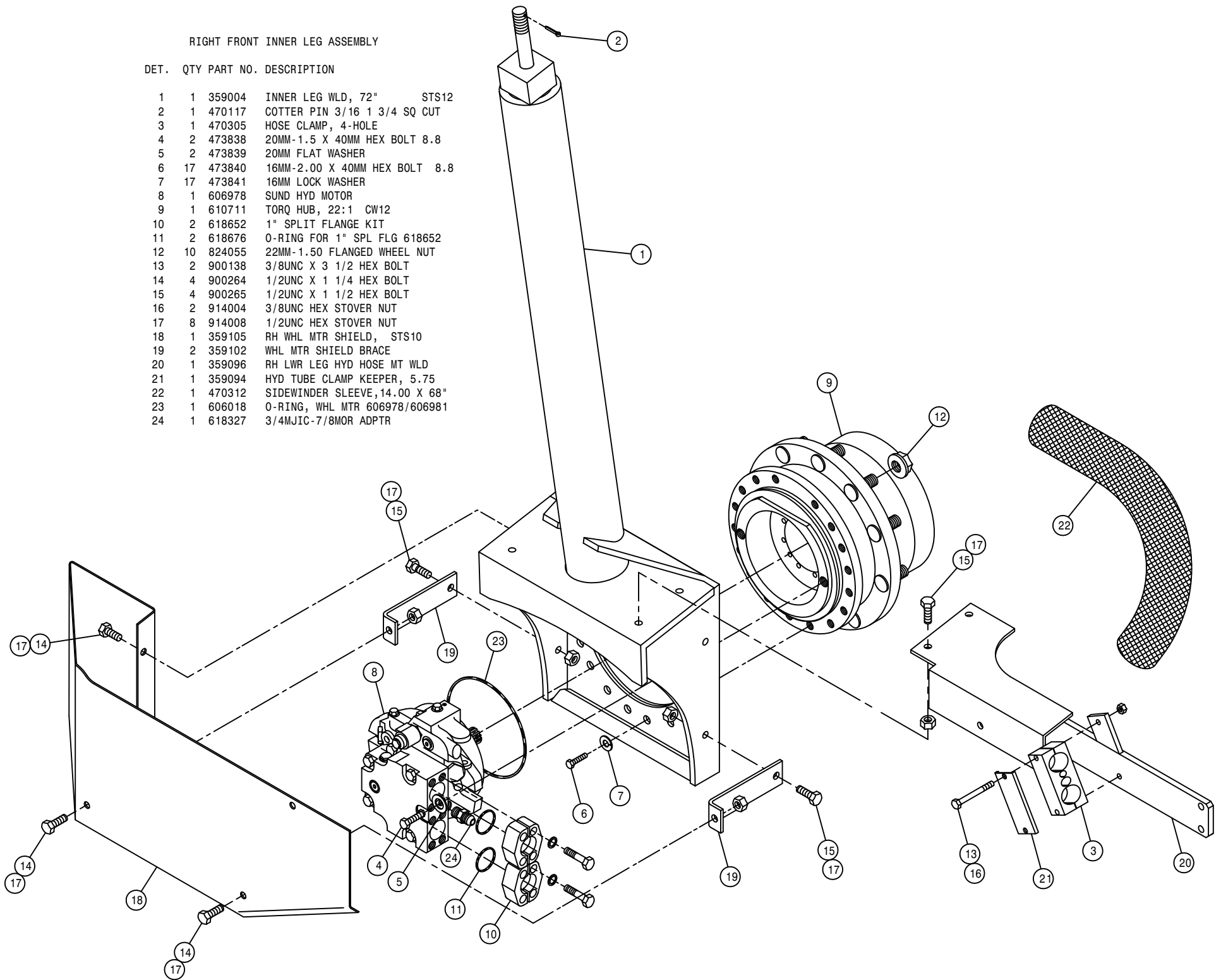

LEFT FRONT OUTER LEG ASSEMBLY

DET. QTY PART NO. DESCRIPTION

1	2	121029	JOURNAL BRG, 1.00 ID X 1.00 LG
2	1	125050	BRG CONE, 1.00 ID W/FACE SEAL
3	1	125051	BRG CUP FOR 125050
4	1	125052	BRG CONE, 2.687 ID W/FACE SEAL
5	1	125053	BRG CUP FOR 125052
6	2	311058	RUBBER SPRING
7	1	311066	AIRIDE SPRING, STS12
8	1	311067	HEIGHT CONTROL AIR VALVE
9	1	311069	7.00 LEVER, CTRL AIR VLV 311067
10	1	311070	LEVER SCREW, CTRL AIR VLV311067
11	1	359005	OUTER LEG WLD, 72" STS12
12	1	470305	HOSE CLAMP, 4-HOLE
13	1	471005	1/4 28 X 1/2 GREASE ZERK
14	1	473975	ROD END, 1"-12 RH MALE
15	1	621050	STEERING CYL ASSY STS12
16	2	629536	RETAINING RING, 6.00 INT SPIRAL
17	2	711036	1/8MNPT-1/4 NYL TUBE FTG
18	1	711040	1/4MNPT-1/4 NYL TUBE LBO
19	1	749322	STEERING TUBE CLAMP & BOLT ASSY
20	2	900006	1/4UNC X 1 3/4 HEX BOLT
21	16	900129	3/8UNC X 1" HEX BOLT
22	2	900138	3/8UNC X 3 1/2 HEX BOLT
23	4	900265	1/2UNC X 1 1/2 HEX BOLT
24	8	900267	1/2UNC X 2" HEX BOLT
25	4	900269	1/2UNC X 2 3/4 HEX BOLT
26	1	900343	5/8UNC X 4 1/2 HEX BOLT
27	2	900352P	5/8UNC X 2 1/4 HEX BOLT
28	1	359085	STEERING ARM BOLT, 1"-8THD STS
29	1	910008	1/2UNC HEX NUT
30	1	910013	3/4UNF HEX NUT
31	1	910021	1" -14 SLOT JAM NUT
32	2	914000	1/4UNC HEX STOVER NUT
33	2	914004	3/8UNC HEX STOVER NUT
34	12	914008	1/2UNC HEX STOVER NUT
35	1	914010	5/8UNC HEX STOVER NUT
36	1	910020	1" UNC HEX SLOTTED NUT
37	1	920008	1" SAE FLAT WASHER
38	16	920502	3/8 LOCK WASHER
39	5	920504	1/2 LOCK WASHER
40	1	920506	3/4 LOCK WASHER
41	2	359084	WASH, 14GA X 4.75ID X 5.875OD
42	1	359058	LH AIR BAG LOWER PLT WLD
43	1	359052	AIR BAG TOWER TOP MT WLD
44	2	359077	TOWER SHAFT WLD
45	1	359082	STEERING ARM BRG SPACER
46	2	121100	LEG SLEEVE BEARING, ORKOT
47	1	359071	LH STEERING ARM WLD
48	1	359050	LH LEG AIR VALVE MT
49	1	359051	LWR AIR VALVE ARM MT
50	1	359081	UPPER LEG HOSE MT PLT
51	1	342719	TRD ADJ BRONZE BEARING, TAPPED
52	2	121105	LEG TOWER SLIDE BEARING, ORKOT
53	1	359094	HYD TUBE CLAMP KEEPER, 5.75
54	1	359095	LEG HEIGHT CTRL LINKAGE, STS12
55	1	359068	UPPER TRUNION MT PLT WLD
56	1	601473	HOSE, 1/4 X 22 AIR
57	1	601479	HOSE, 1/4 X 196 AIR
58	1	470310	SIDEWINDER SLEEVE, 13.50 X 45"
59	1	471021	GREASE ZERK 1/8 NPT STRAIGHT
60	3	342917	TREAD ADJ PLATE, STEEL STS10
61	2	914010P	5/8UNC HEX STOVER NUT
62	1	470117	COTTER PIN 3/16 1 3/4 SQ CUT

*NOTE: FOR TREAD ADJUST OPTION REPLACE ITEM 60 WITH THREE OF ITEM 51.

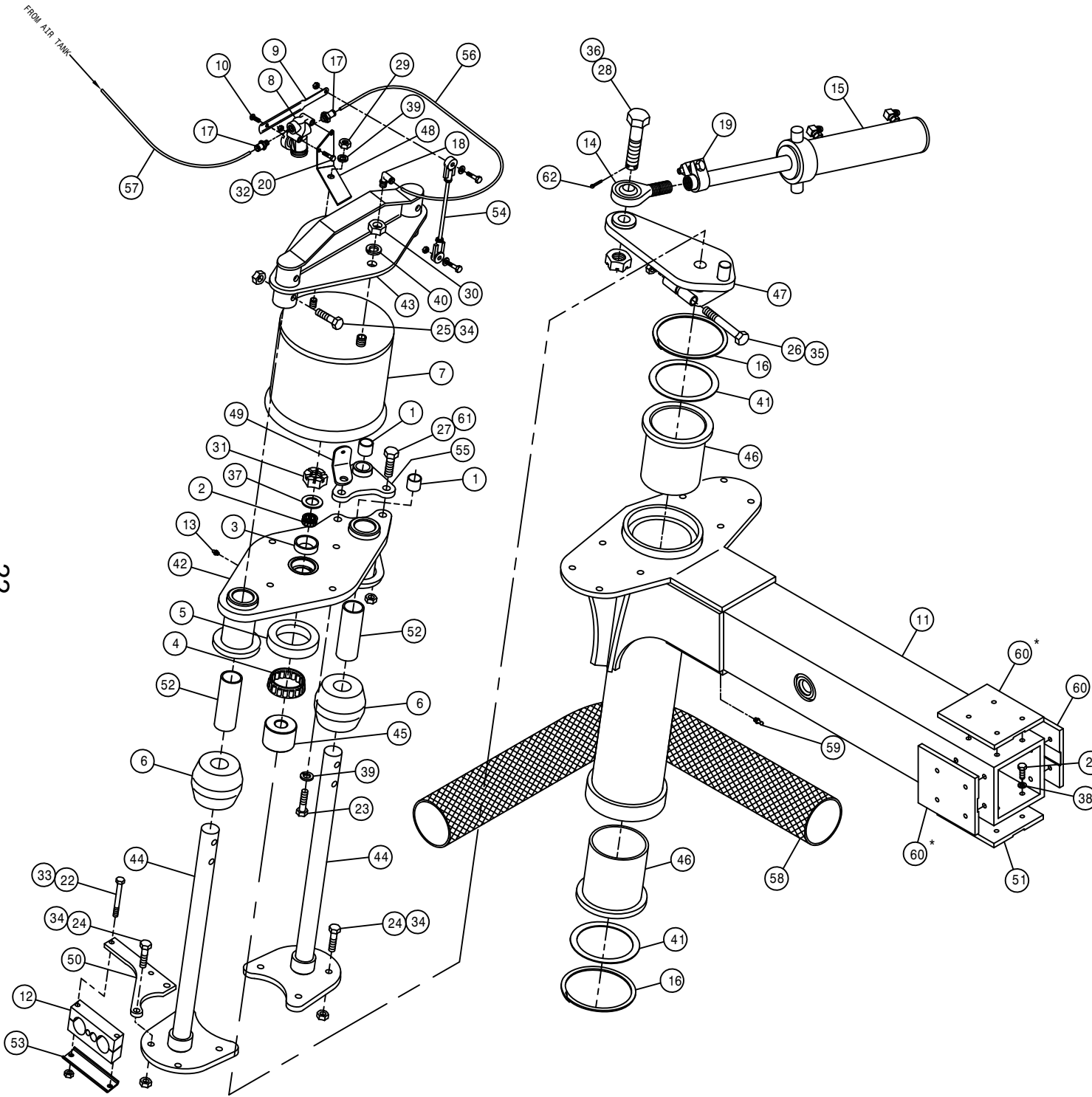

LEFT FRONT INNER LEG ASSEMBLY

DET. QTY PART NO. DESCRIPTION

1	1	359004	INNER LEG WLD, 72"	STS12
2	1	470117	COTTER PIN 3/16 1 3/4 SQ CUT	
3	1	470305	HOSE CLAMP, 4-HOLE	
4	2	473838	20MM-1.5 X 40MM HEX BOLT 8.8	
5	2	473839	20MM FLAT WASHER	
6	17	473840	16MM-2.00 X 40MM HEX BOLT 8.8	
7	17	473841	16MM LOCK WASHER	
8	1	606978	SUND HYD MOTOR	
9	1	610711	TORQ HUB, 22:1 CW12	
10	2	618652	1" SPLIT FLANGE KIT	
11	2	618676	O-RING FOR 1" SPL FLG 618652	
12	10	824055	22MM-1.50 FLANGED WHEEL NUT	
13	2	900138	3/8UNC X 3 1/2 HEX BOLT	
14	4	900264	1/2UNC X 1 1/4 HEX BOLT	
15	4	900265	1/2UNC X 1 1/2 HEX BOLT	
16	2	914004	3/8UNC HEX STOVER NUT	
17	8	914008	1/2UNC HEX STOVER NUT	
18	1	359106	LH WHL MTR SHIELD, STS10	
19	2	359102	WHL MTR SHIELD BRACE	
20	1	359097	LH LWR LEG HYD HOSE MT WLD	
21	1	359094	HYD TUBE CLAMP KEEPER, 5.75	
22	1	470312	SIDEWINDER SLEEVE, 14.00 X 68"	
23	1	606018	O-RING, WHL MTR 606978/606981	
24	1	618327	3/4MJIC-7/8MOR ADPTR	

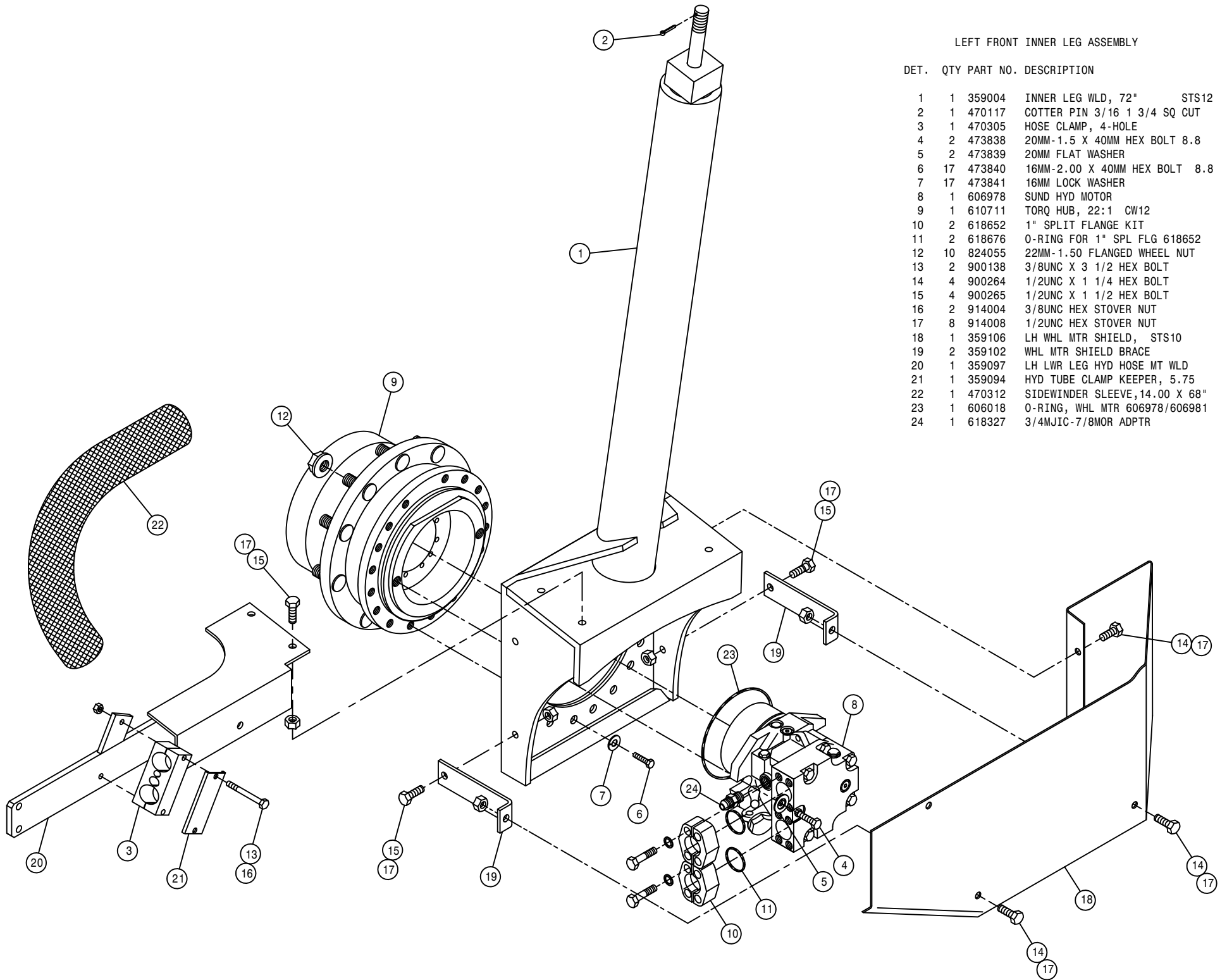

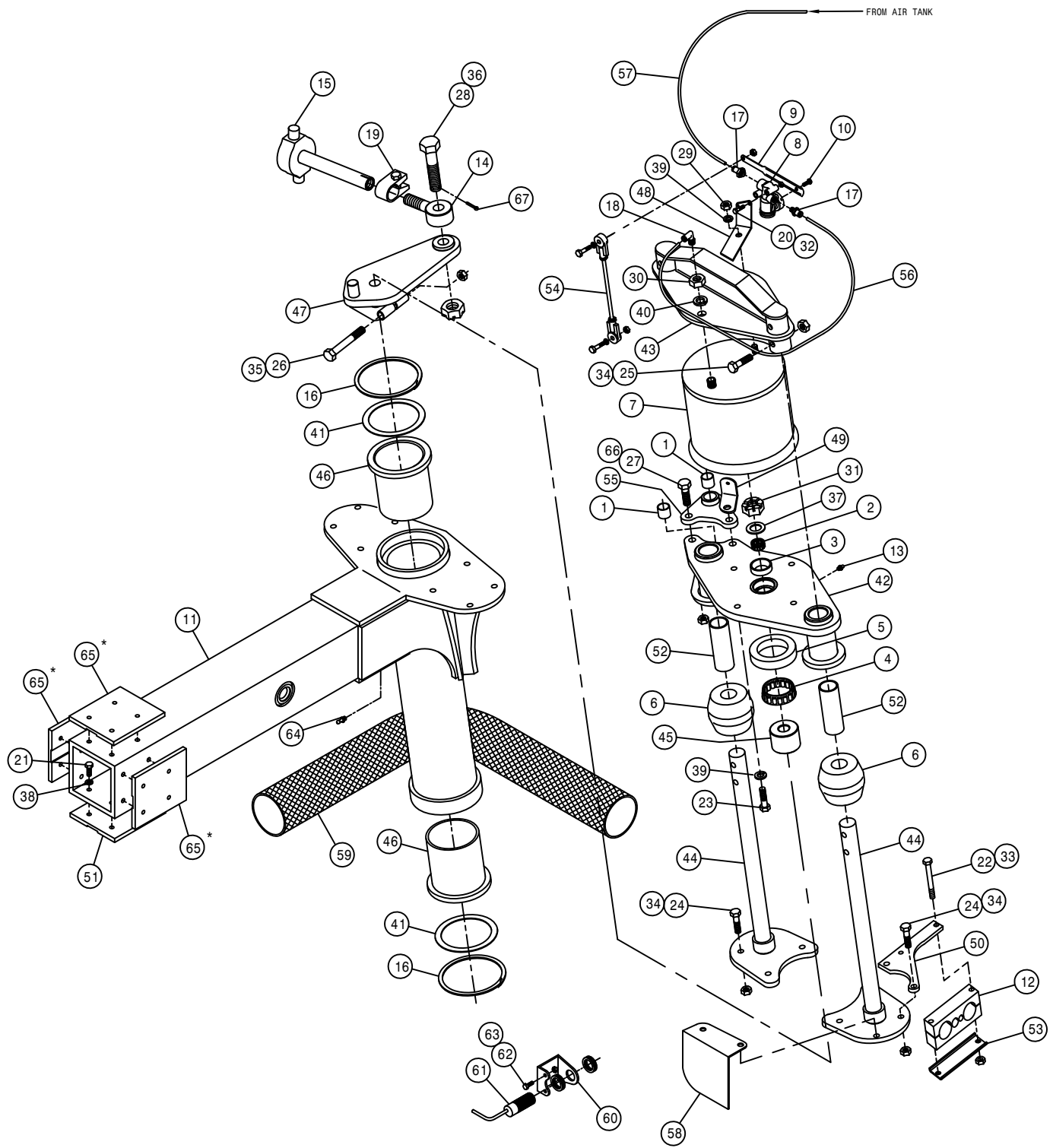

RIGHT REAR OUTER LEG ASSEMBLY

DET.	QTY	PART NO.	DESCRIPTION
	1	2	121029 JOURNAL BRG, 1.00 ID X 1.00 LG
	2	1	125050 BRG CONE, 1.00 ID W/FACE SEAL
	3	1	125051 BRG CUP FOR 125050
	4	1	125052 BRG CONE, 2.687 ID W/FACE SEAL
	5	1	125053 BRG CUP FOR 125052
	6	2	311058 RUBBER SPRING
	7	1	311066 AIRIDE SPRING, STS12
	8	1	311067 HEIGHT CONTROL AIR VALVE
	9	1	311069 7.00 LEVER, CTRL AIR VLV 311067
	10	1	311070 LEVER SCREW, CTRL AIR VLV 311067
	11	1	359005 OUTER LEG WLD, 72" STS12
	12	1	470305 HOSE CLAMP, 4-HOLE
	13	1	471005 1/4 28 X 1/2 GREASE ZERK
	14	1	359089 TIE ROD STUD WLD
	15	1	359086 REAR TIE ROD SHAFT WLD
	16	2	629536 RETAINING RING, 6.00 INT SPIRAL
	17	2	711036 1/8MNPT-1/4 NYL TUBE FTG
	18	1	711040 1/4MNPT-1/4 NYL TUBE LBO
	19	1	749322 STEERING TUBE CLAMP & BOLT ASSY
	20	2	900006 1/4UNC X 1 3/4 HEX BOLT
	21	16	900129 3/8UNC X 1" HEX BOLT
	22	2	900138 3/8UNC X 3 1/2 HEX BOLT
	23	4	900265 1/2UNC X 1 1/2 HEX BOLT
	24	8	900267 1/2UNC X 2" HEX BOLT
	25	4	900269 1/2UNC X 2 3/4 HEX BOLT
	26	1	900343 5/8UNC X 4 1/2 HEX BOLT
	27	2	900352P 5/8UNC X 2 1/4 HEX BOLT
	28	1	359085 STEERING ARM BOLT, 1"-8THD STS
	29	1	910008 1/2UNC HEX NUT
	30	1	910013 3/4UNF HEX NUT
	31	1	910021 1"-14 SLOT JAM NUT
	32	2	914000 1/4UNC HEX STOVER NUT
	33	2	914004 3/8UNC HEX STOVER NUT
	34	12	914008 1/2UNC HEX STOVER NUT
	35	1	914010 5/8UNC HEX STOVER NUT
	36	1	910020 1" UNC HEX SLOTTED NUT
	37	1	920008 1" SAE FLAT WASHER
	38	16	920502 3/8 LOCK WASHER
	39	5	920504 1/2 LOCK WASHER
	40	1	920506 3/4 LOCK WASHER
	41	2	359084 WASH, 14GA X 4.75ID X 5.875OD
	42	1	359057 RH AIR BAG LOWER PLT WLD
	43	1	359052 AIR BAG TOWER TOP MT WLD
	44	2	359077 TOWER SHAFT WLD
	45	1	359082 STEERING ARM BRG SPACER
	46	2	121100 LEG SLEEVE BEARING, ORKOT
	47	1	359070 RH STEERING ARM WLD
	48	1	359049 RH LEG AIR VALVE MT
	49	1	359051 LWR AIR VALVE ARM MT
	50	1	359081 UPPER LEG HOSE MT PLT
	51	1	342719 TRD ADJ BRONZE BEARING, TAPPED
	52	2	121105 LEG TOWER SLIDE BEARING, ORKOT
	53	1	359094 HYD TUBE CLAMP KEEPER, 5.75
	54	1	359095 LEG HEIGHT CTRL LINKAGE, STS12
	55	1	359068 UPPER TRUNION MT PLT WLD
	56	1	601473 HOSE, 1/4 X 22 AIR
	57	1	601477 HOSE, 1/4 X 160 AIR
	58	1	359092 RH SENSOR REFLECTOR
	59	1	470311 SIDEWINDER SLEEVE, 14.00 X 60"
	60	1	342856 TREAD SENSOR MT
	61	1	293637 SENSOR W/SHROUD ASSY (SERV)
	62	2	900064 5/16UNC X 3/4 HEX BOLT
	63	2	914002 5/16UNC HEX STOVER NUT
	64	1	471021 GREASE ZERK 1/8 NPT STRAIGHT
	65	3	342917 TREAD ADJ PLATE, STEEL STS10
	66	2	914010P 5/8UNC HEX STOVER NUT
	67	1	470117 COTTER PIN 3/16 1 3/4 SQ CUT

*NOTE: FOR TREAD ADJUST OPTION REPLACE ITEM 65 WITH THREE OF ITEM 51.

RIGHT REAR INNER LEG ASSEMBLY

DET. QTY PART NO. DESCRIPTION

1	1	359004	INNER LEG WLD, 72" STS12
2	1	470117	COTTER PIN 3/16 1 3/4 SQ CUT
3	1	470305	HOSE CLAMP, 4-HOLE
4	2	473838	20MM-1.5 X 40MM HEX BOLT 8.8
5	2	473839	20MM FLAT WASHER
6	17	473840	16MM-2.00 X 40MM HEX BOLT 8.8
7	17	473841	16MM LOCK WASHER
8	1	606978	SUND HYD MOTOR
9	1	610714	TORQ HUB, 27:1 CW12
10	1	618666	7/16MJIC-M12X1.5MOR ADPTR
11	2	618652	1" SPLIT FLANGE KIT
12	2	618676	O-RING FOR 1" SPL FLG 618652
13	10	824055	22MM-1.50 FLANGED WHEEL NUT
14	2	900138	3/8UNC X 3 1/2 HEX BOLT
15	4	900264	1/2UNC X 1 1/4 HEX BOLT
16	4	900265	1/2UNC X 1 1/2 HEX BOLT
17	2	914004	3/8UNC HEX STOVER NUT
18	8	914008	1/2UNC HEX STOVER NUT
19	1	359105	RH WHL MTR SHIELD, STS10
20	2	359102	WHL MTR SHIELD BRACE
21	1	359096	RH LWR LEG HYD HOSE MT WLD
22	1	359094	HYD TUBE CLAMP KEEPER, 5.75
23	1	470312	SIDEWINDER SLEEVE, 14.00 X 68"
24	1	606018	O-RING, WHL MTR 606978/606981
25	1	618327	3/4MJIC-7/8MOR ADPTR

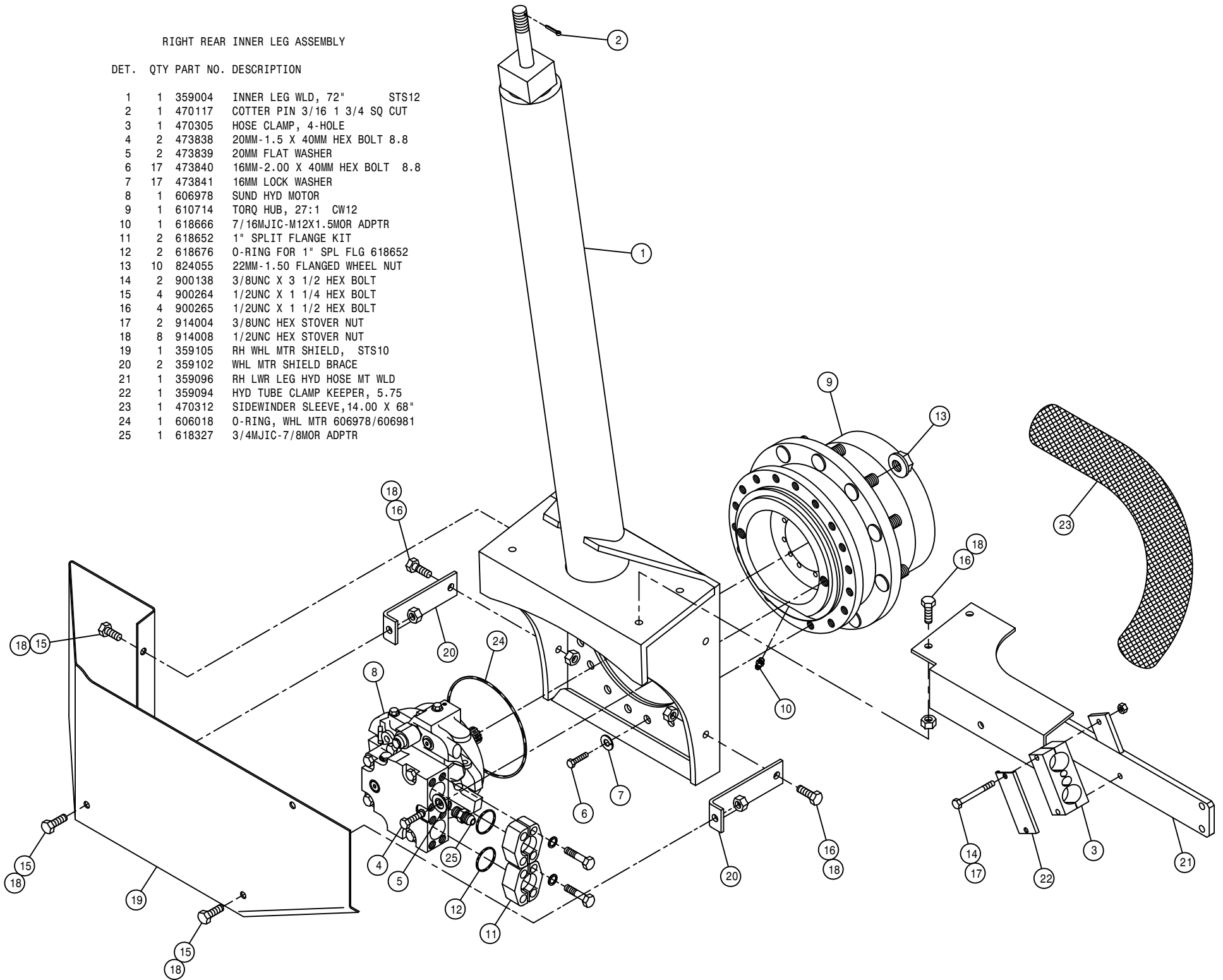

LEFT REAR OUTER LEG ASSEMBLY

DET.	QTY	PART NO.	DESCRIPTION
1	2	121029	JOURNAL BRG, 1.00 ID X 1.00 LG
2	1	125050	BRG CONE, 1.00 ID W/FACE SEAL
3	1	125051	BRG CUP FOR 125050
4	1	125052	BRG CONE, 2.687 ID W/FACE SEAL
5	1	125053	BRG CUP FOR 125052
6	2	311058	RUBBER SPRING
7	1	311066	AIRIDE SPRING, STS12
8	1	311067	HEIGHT CONTROL AIR VALVE
9	1	311069	7.00 LEVER, CTRL AIR VLV 311067
10	1	311070	LEVER SCREW, CTRL AIR VLV311067
11	1	359005	OUTER LEG WLD, 72" STS12
12	1	470305	HOSE CLAMP, 4-HOLE
13	1	471005	1/4 28 X 1/2 GREASE ZERK
14	1	359089	TIE ROD STUD WLD
15	1	359086	REAR TIE ROD SHAFT WLD
16	2	629536	RETAINING RING, 6.00 INT SPIRAL
17	2	711036	1/8MNPT-1/4 NYL TUBE FTG
18	1	711040	1/4MNPT-1/4 NYL TUBE LBO
19	1	749322	STEERING TUBE CLAMP & BOLT ASSY
20	2	900006	1/4UNC X 1 3/4 HEX BOLT
21	16	900129	3/8UNC X 1" HEX BOLT
22	2	900138	3/8UNC X 3 1/2 HEX BOLT
23	4	900265	1/2UNC X 1 1/2 HEX BOLT
24	8	900267	1/2UNC X 2" HEX BOLT
25	4	900269	1/2UNC X 2 3/4 HEX BOLT
26	1	900343	5/8UNC X 4 1/2 HEX BOLT
27	2	900352P	5/8UNC X 2 1/4 HEX BOLT
28	1	359085	STEERING ARM BOLT, 1"-8THD STS
29	1	910008	1/2UNC HEX NUT
30	1	910013	3/4UNF HEX NUT
31	1	910021	1" -14 SLOT JAM NUT
32	2	914000	1/4UNC HEX STOVER NUT
33	2	914004	3/8UNC HEX STOVER NUT
34	12	914008	1/2UNC HEX STOVER NUT
35	1	914010	5/8UNC HEX STOVER NUT
36	1	910020	1" UNC HEX SLOTTED NUT
37	1	920008	1" SAE FLAT WASHER
38	16	920502	3/8 LOCK WASHER
39	5	920504	1/2 LOCK WASHER
40	1	920506	3/4 LOCK WASHER
41	2	359084	WASH, 14GA X 4.75ID X 5.875OD
42	1	359058	LH AIR BAG LOWER PLT WLD
43	1	359052	AIR BAG TOWER TOP MT WLD
44	2	359077	TOWER SHAFT WLD
45	1	359082	STEERING ARM BRG SPACER
46	2	121100	LEG SLEEVE BEARING, ORKOT
47	1	359071	LH STEERING ARM WLD
48	1	359050	LH LEG AIR VALVE MT
49	1	359051	LWR AIR VALVE ARM MT
50	1	359081	UPPER LEG HOSE MT PLT
51	1	342719	TRD ADJ BRONZE BEARING, TAPPED
52	2	121105	LEG TOWER SLIDE BEARING, ORKOT
53	1	359094	HYD TUBE CLAMP KEEPER, 5.75
54	1	359095	LEG HEIGHT CTRL LINKAGE, STS12
55	1	359068	UPPER TRUNION MT PLT WLD
56	1	601473	HOSE, 1/4 X 22 AIR
57	1	601476	HOSE, 1/4 X 120 AIR
58	1	359093	LH SENSOR REFLECTOR
59	1	470311	SIDEWINDER SLEEVE, 14.00 X 60"
60	1	342856	TREAD SENSOR MT
61	1	293637	SENSOR W/SHROUD ASSY (SERV)
62	2	900064	5/16UNC X 3/4 HEX BOLT
63	2	914002	5/16UNC HEX STOVER NUT
64	1	471021	GREASE ZERK 1/8 NPT STRAIGHT
65	3	342917	TREAD ADJ PLATE, STEEL STS10
66	2	914010P	5/8UNC HEX STOVER NUT
67	1	470117	COTTER PIN 3/16 1 3/4 SQ CUT

*NOTE: FOR TREAD ADJUST OPTION REPLACE ITEM 65 WITH THREE OF ITEM 51.

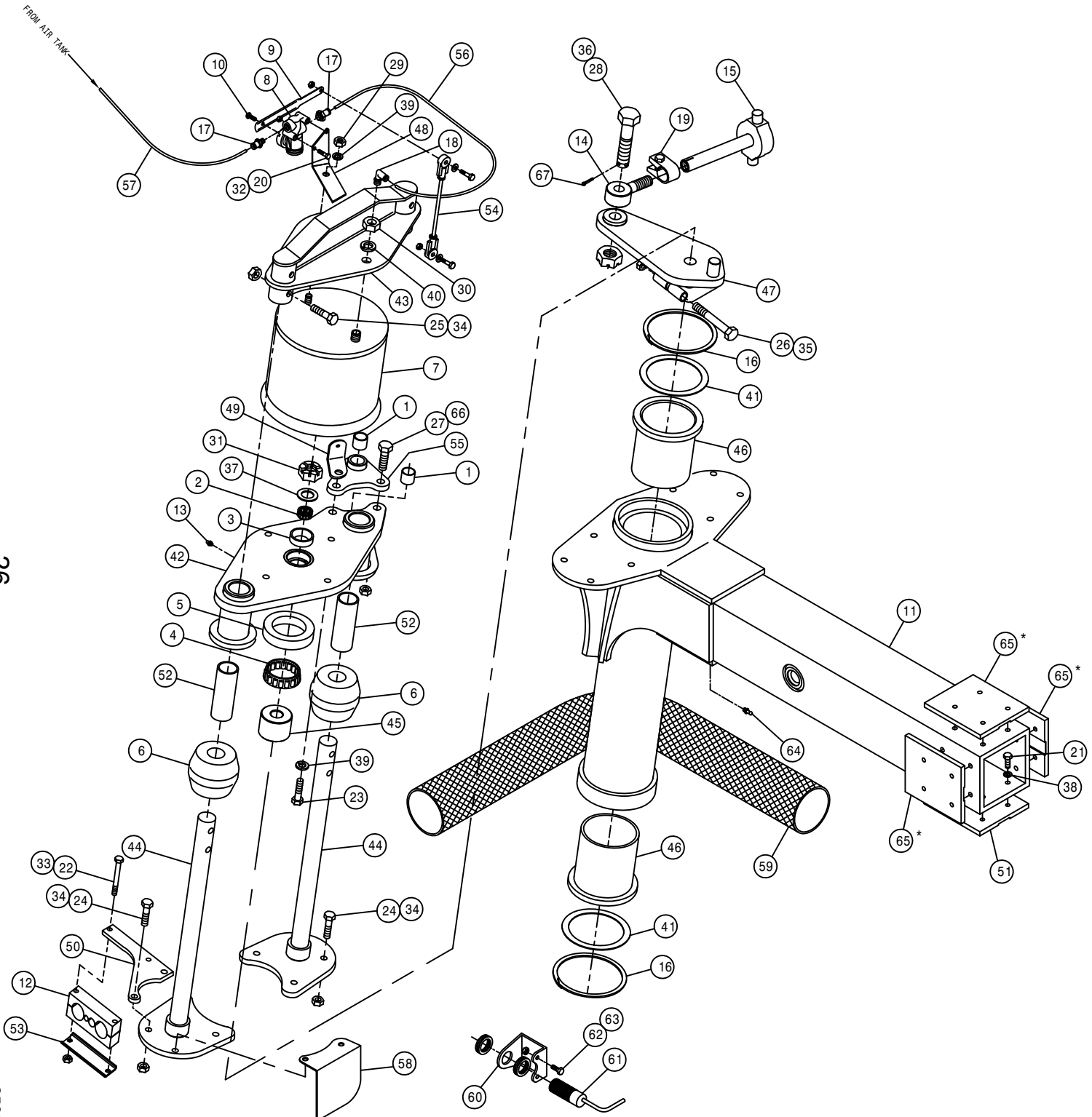

26

250026

LEFT REAR INNER LEG ASSEMBLY

DET. QTY PART NO. DESCRIPTION

1	1	359004	INNER LEG WLD, 72"	STS12
2	1	470117	COTTER PIN 3/16 1 3/4 SQ CUT	
3	1	470305	HOSE CLAMP, 4-HOLE	
4	2	473838	20MM-1.5 X 40MM HEX BOLT 8.8	
5	2	473839	20MM FLAT WASHER	
6	17	473840	16MM-2.00 X 40MM HEX BOLT 8.8	
7	17	473841	16MM LOCK WASHER	
8	1	606981	SUND HYD MOTOR W/SENSOR	
9	1	610714	TORQ HUB, 27:1 CW12	
10	1	618666	7/16MJIC-M12X1.5MOR ADPTR	
11	2	618652	1" SPLIT FLANGE KIT	
12	2	618676	O-RING FOR 1" SPL FLG 618652	
13	10	824055	22MM-1.50 FLANGED WHEEL NUT	
14	2	900138	3/8UNC X 3 1/2 HEX BOLT	
15	4	900264	1/2UNC X 1 1/4 HEX BOLT	
16	4	900265	1/2UNC X 1 1/2 HEX BOLT	
17	2	914004	3/8UNC HEX STOVER NUT	
18	8	914008	1/2UNC HEX STOVER NUT	
19	1	359106	LH WHL MTR SHIELD, STS10	
20	2	359102	WHL MTR SHIELD BRACE	
21	1	359097	LH LWR LEG HYD HOSE MT WLD	
22	1	359094	HYD TUBE CLAMP KEEPER, 5.75	
23	1	606996	SPEED SENSOR, SUND MOTOR 606981	
24	1	470312	SIDEWINDER SLEEVE, 14.00 X 68"	
25	1	606018	O-RING, WHL MTR 606978/606981	
26	1	618327	3/4MJIC-7/8MOR ADPTR	

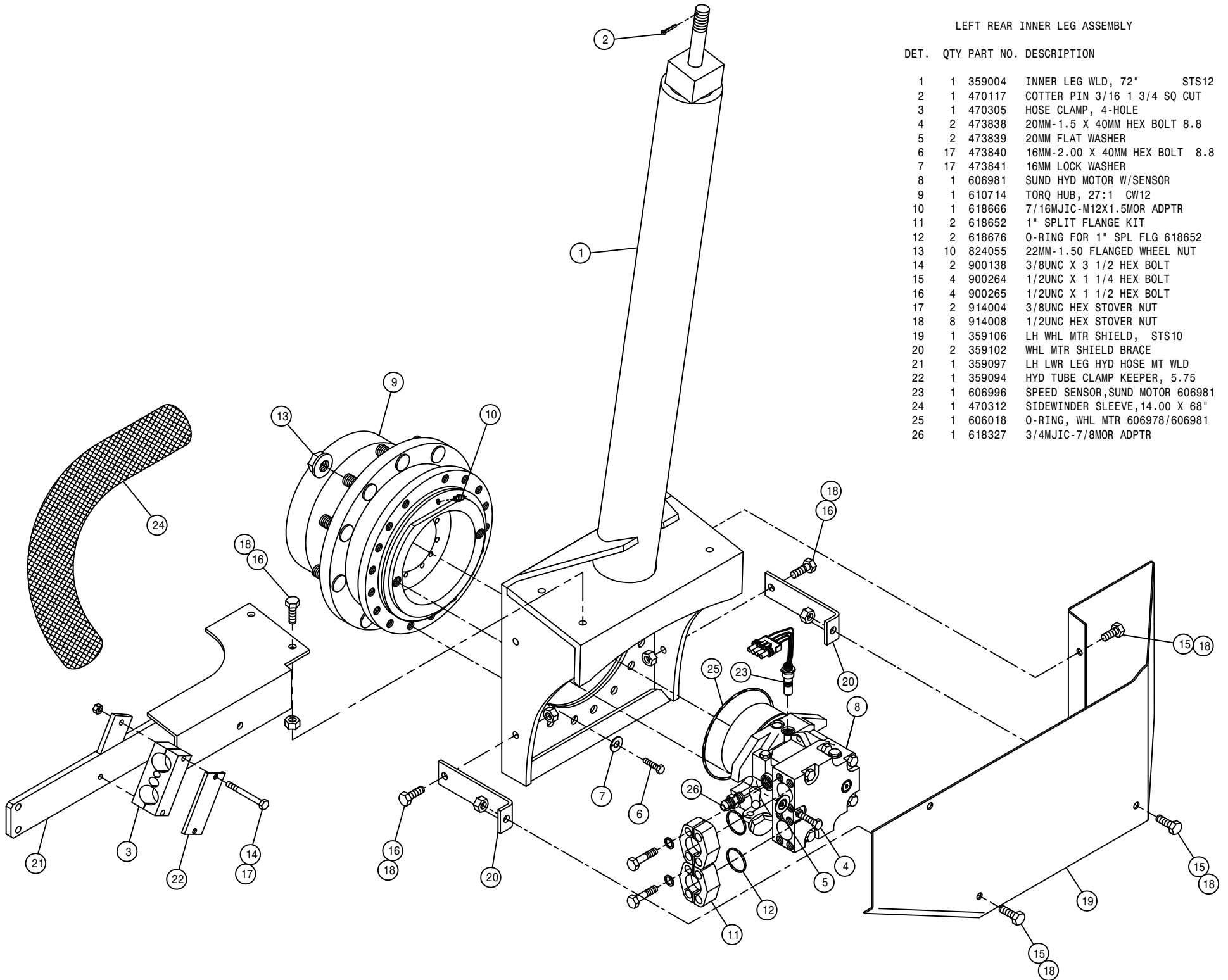

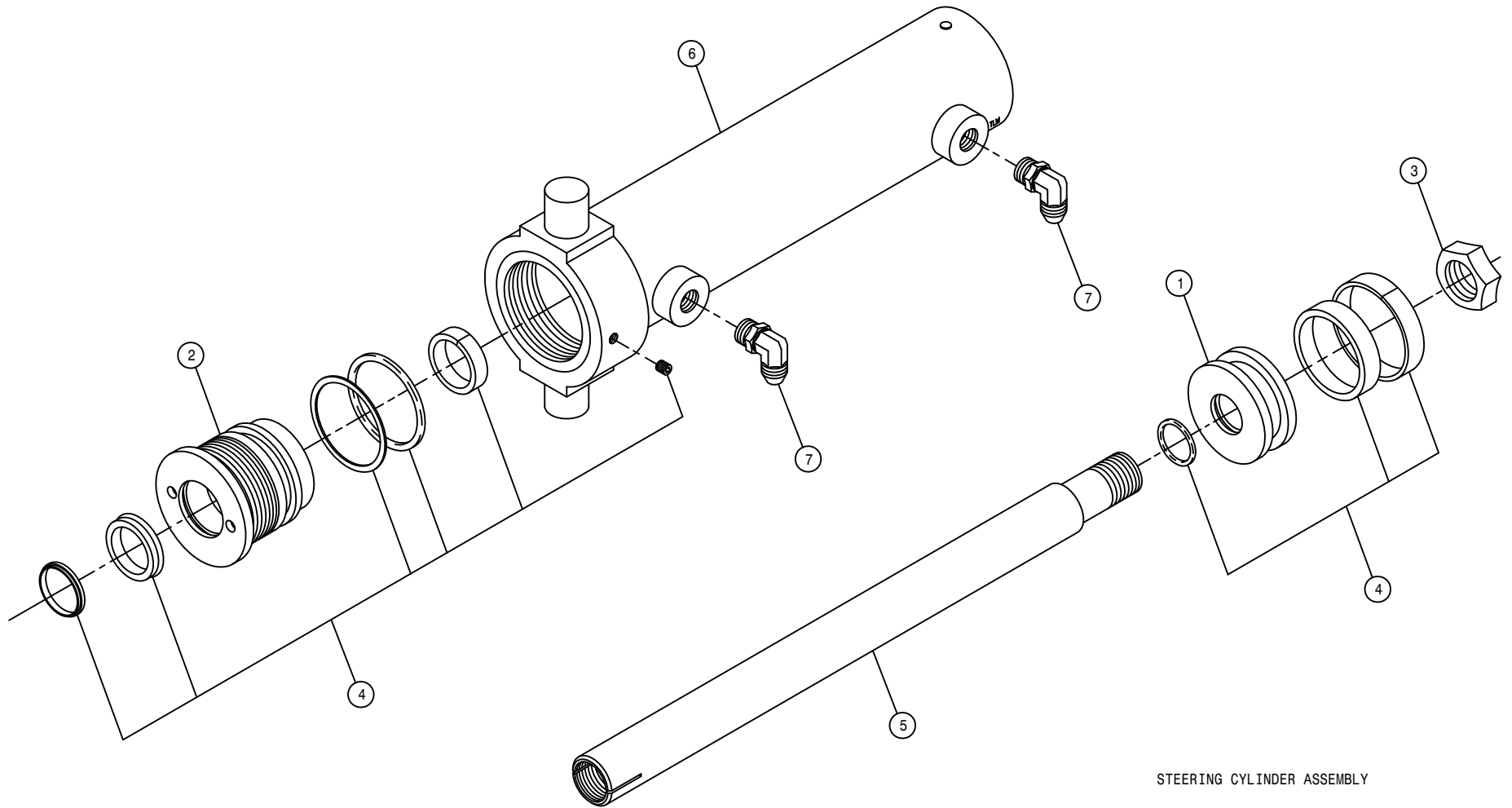

STEERING CYLINDER ASSEMBLY

DET.	QTY	PART NO.	DESCRIPTION
	1	620733	PISTON, P-2.50-109
	1	620748	HEAD, H-2.50-350
	1	620765	NUT, N-1.00-01
	1	620788	REPAIR KIT, HYD CYL, RK-2.50-803
	1	620913	SHAFT WLD, STRG CYL 620910
	1	620914	BARREL WLD, STRG CYL 620910
	2	618249	3/4MJIC-90-9/16MOR LBO

NOTE: 1. 620910 - STEERING CYLINDER ASSEMBLY ITEMS 1-6
 2. 621050 - STEERING CYLINDER ASSEMBLY WITH FITTINGS

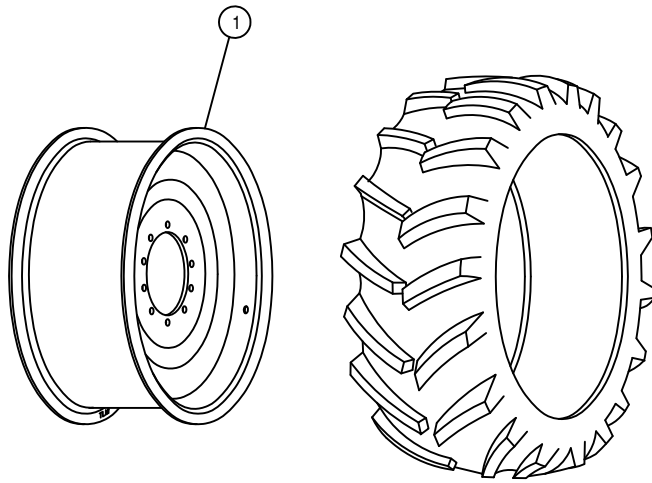

580/70 R38 RADIAL TIRE

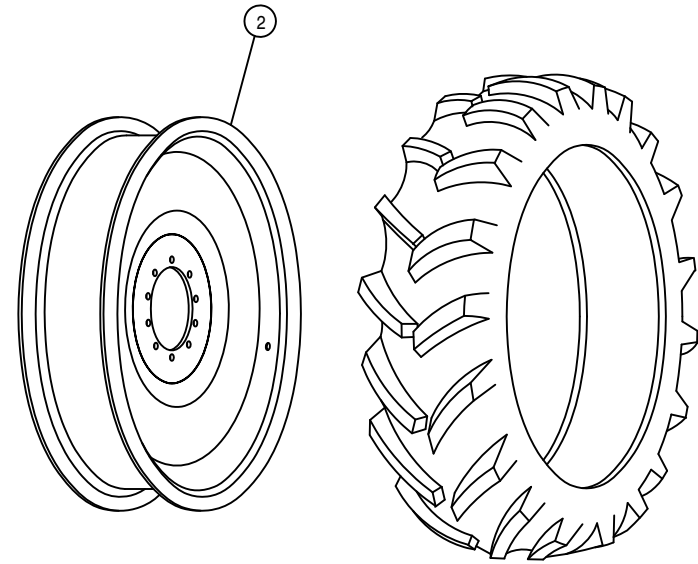

380/90 R46 RADIAL TIRE

OR
380/85 R46 RADIAL TIRE

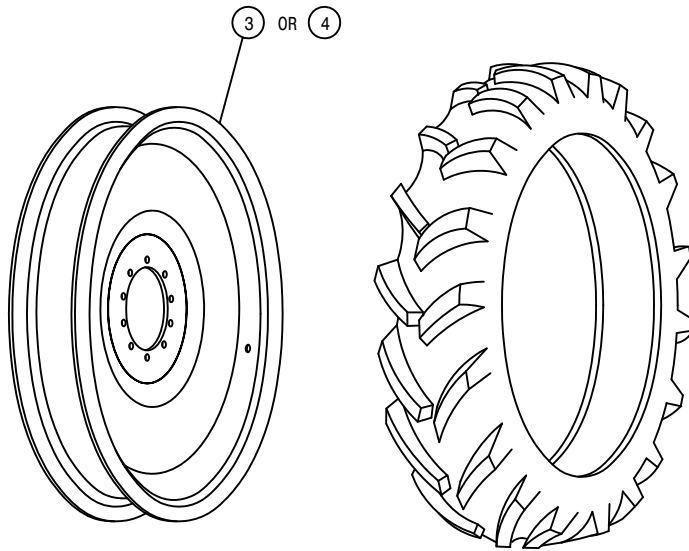

320/90 R50 RADIAL TIRE

TIRE AND RIM ASSEMBLY

DET.	QTY	PART NO.	DESCRIPTION	
1	1	821055	RIM WLD, 38 X W18A	STS12
2	1	821054	RIM WLD, 46 X W13A	STS12
3	1	821053	RIM WLD, 50 X DW10	STS12
4	1	821056	RIM WLD,50 X 10 TITAN	

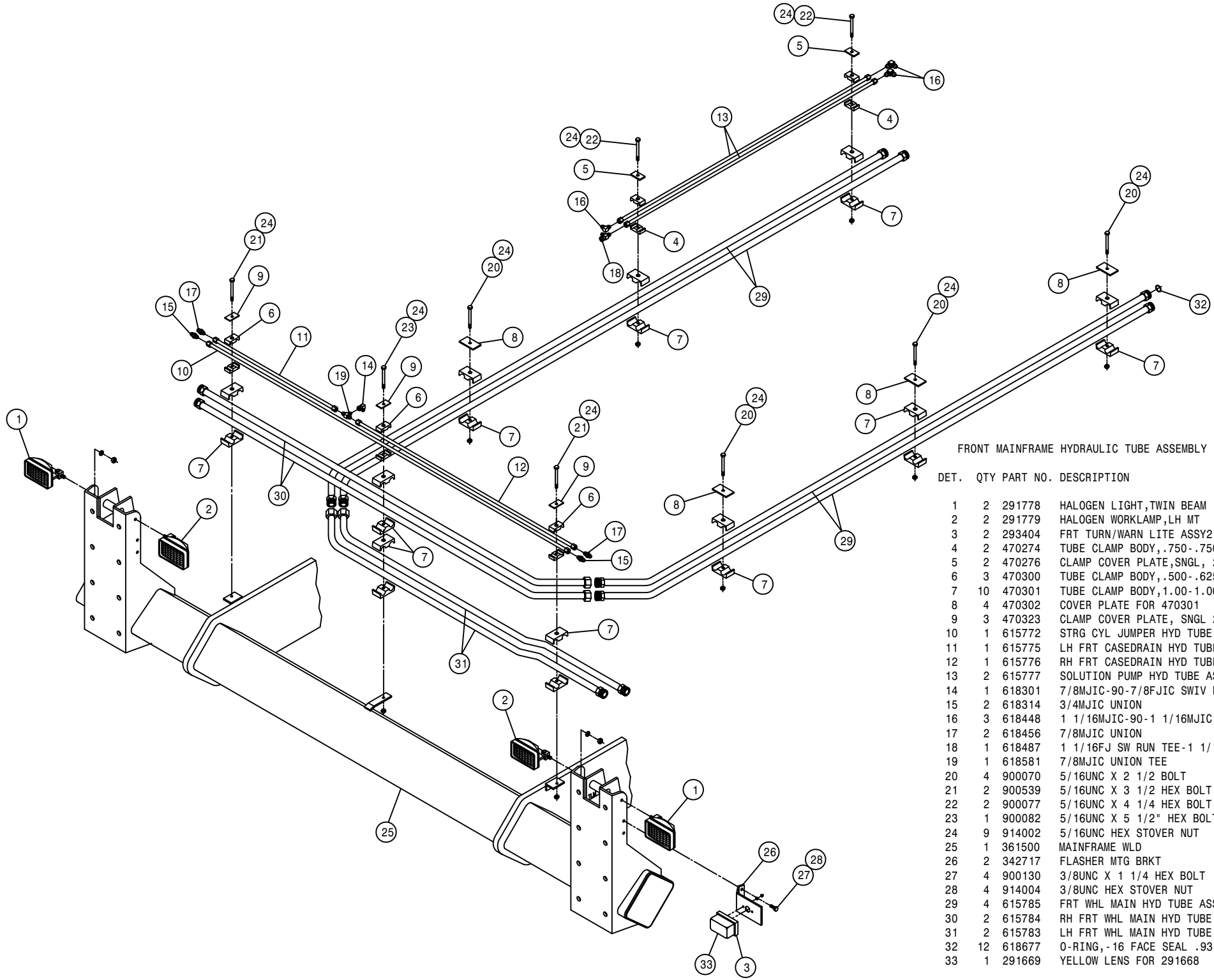

FRONT MAINFRAME HYDRAULIC TUBE ASSEMBLY

DET.	QTY	PART NO.	DESCRIPTION
1	2	291778	HALOGEN LIGHT,TWIN BEAM 12V55W
2	2	291779	HALOGEN WORKLAMP,LH MT 12V55W
3	2	293404	FRT TURN/WARN LITE ASSY2100 98
4	2	470274	TUBE CLAMP BODY, .750- .750
5	2	470276	CLAMP COVER PLATE,SNGL, 2.55LG
6	3	470300	TUBE CLAMP BODY, .500- .625
7	10	470301	TUBE CLAMP BODY,1.00-1.00
8	4	470302	COVER PLATE FOR 470301
9	3	470323	CLAMP COVER PLATE, SNGL 2.04LG
10	1	615772	STRG CYL JUMPER HYD TUBE ASSY
11	1	615775	LH FRT CASEDRAIN HYD TUBE ASSY
12	1	615776	RH FRT CASEDRAIN HYD TUBE ASSY
13	2	615777	SOLUTION PUMP HYD TUBE ASSY
14	1	618301	7/8MJIC-90-7/8FJIC SWIV LBO
15	2	618314	3/4MJIC UNION
16	3	618448	1 1/16MJIC-90-1 1/16MJIC LBO
17	2	618456	7/8MJIC UNION
18	1	618487	1 1/16FJ SW RUN TEE-1 1/16MJ
19	1	618581	7/8MJIC UNION TEE
20	4	900070	5/16UNC X 2 1/2 BOLT
21	2	900539	5/16UNC X 3 1/2 HEX BOLT
22	2	900077	5/16UNC X 4 1/4 HEX BOLT
23	1	900082	5/16UNC X 5 1/2" HEX BOLT
24	9	914002	5/16UNC HEX STOVER NUT
25	1	361500	MAINFRAME WLD STS12
26	2	342717	FLASHER MTG BRKT
27	4	900130	3/8UNC X 1 1/4 HEX BOLT
28	4	914004	3/8UNC HEX STOVER NUT
29	4	615785	FRT WHL MAIN HYD TUBE ASSY
30	2	615784	RH FRT WHL MAIN HYD TUBE ASSY
31	2	615783	LH FRT WHL MAIN HYD TUBE ASSY
32	12	618677	O-RING, -16 FACE SEAL .93ID 90D
33	1	291669	YELLOW LENS FOR 291668

30

250030

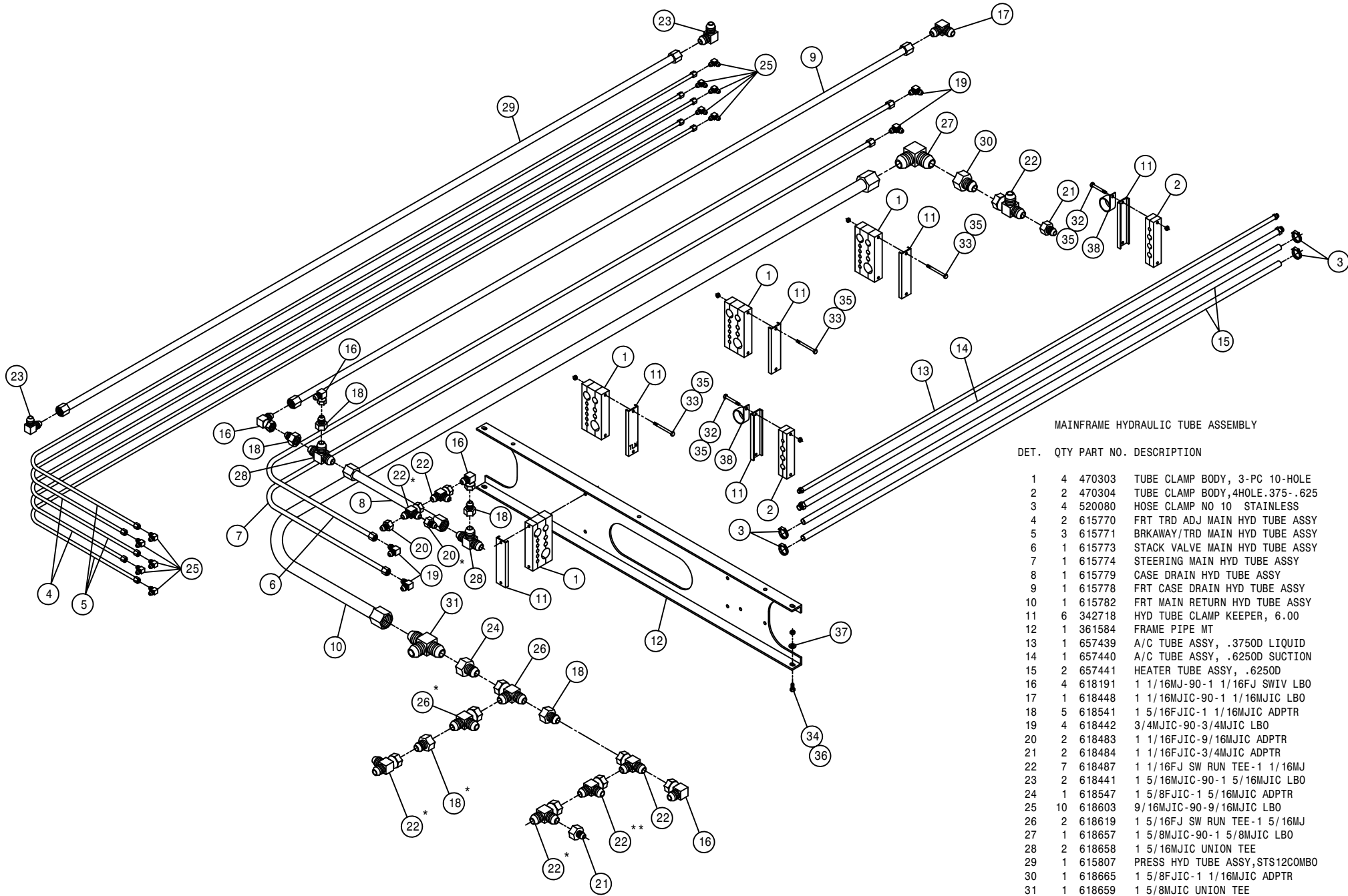

MAINFRAME HYDRAULIC TUBE ASSEMBLY

DET.	QTY	PART NO.	DESCRIPTION
1	4	470303	TUBE CLAMP BODY, 3-PC 10-HOLE
2	2	470304	TUBE CLAMP BODY,4HOLE.375-.625
3	4	520080	HOSE CLAMP NO 10 STAINLESS
4	2	615770	FRT TRD ADJ MAIN HYD TUBE ASSY
5	3	615771	BRKAWAY/TRD MAIN HYD TUBE ASSY
6	1	615773	STACK VALVE MAIN HYD TUBE ASSY
7	1	615774	STEERING MAIN HYD TUBE ASSY
8	1	615779	CASE DRAIN HYD TUBE ASSY
9	1	615778	FRT CASE DRAIN HYD TUBE ASSY
10	1	615782	FRT MAIN RETURN HYD TUBE ASSY
11	6	342718	HYD TUBE CLAMP KEEPER, 6.00
12	1	361584	FRAME PIPE MT
13	1	657439	A/C TUBE ASSY, .375OD LIQUID
14	1	657440	A/C TUBE ASSY, .625OD SUCTION
15	2	657441	HEATER TUBE ASSY, .625OD
16	4	618191	1 1/16MJ-90-1 1/16FJ SWIV LBO
17	1	618448	1 1/16MJIC-90-1 1/16MJIC LBO
18	5	618541	1 5/16FJIC-1 1/16MJIC ADPTR
19	4	618442	3/4MJIC-90-3/4MJIC LBO
20	2	618483	1 1/16FJIC-9/16MJIC ADPTR
21	2	618484	1 1/16FJIC-3/4MJIC ADPTR
22	7	618487	1 1/16FJ SW RUN TEE-1 1/16MJ
23	2	618441	1 5/16MJIC-90-1 5/16MJIC LBO
24	1	618547	1 5/8FJIC-1 5/16MJIC ADPTR
25	10	618603	9/16MJIC-90-9/16MJIC LBO
26	2	618619	1 5/16FJ SW RUN TEE-1 5/16MJ
27	1	618657	1 5/8MJIC-90-1 5/8MJIC LBO
28	2	618658	1 5/16MJIC UNION TEE
29	1	615807	PRESS HYD TUBE ASSY,STS12COMBO
30	1	618665	1 5/8FJIC-1 1/16MJIC ADPTR
31	1	618659	1 5/8MJIC UNION TEE
32	4	900007	1/4UNC X 2" HEX BOLT
33	8	900014	1/4UNC X 4" HEX BOLT
34	4	900129	3/8UNC X 1" HEX BOLT
35	12	914000	1/4UNC HEX STOVER NUT
36	4	914004	3/8UNC HEX STOVER NUT
37	4	920002	3/8 SAE FLAT WASHER
38	2	520126	CUSH HOSE CLAMP 2IN X 5/8W

NOTE: ITEMS MARKED WITH A (*) ARE USED WITH THE SIDE FILL OPTION AND PRESSURE WASHER OPTION.

ITEMS MARKED WITH A (**) ARE USED WITH TREAD ADJUST OPTION.

TREAD ADJUST ASSEMBLY

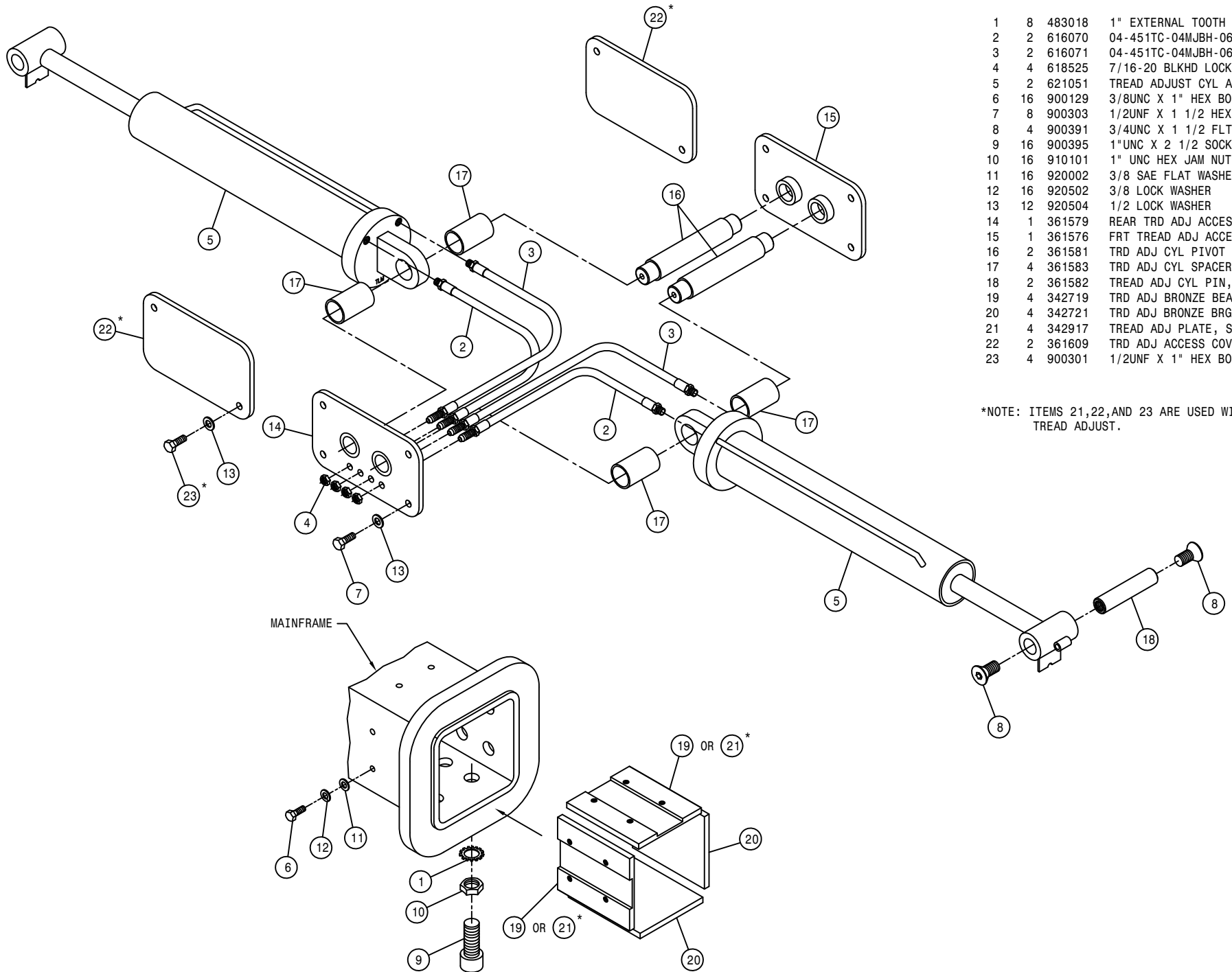

DET.	QTY	PART NO.	DESCRIPTION
1	8	483018	1" EXTERNAL TOOTH LOCK WASHER
2	2	616070	04-451TC-04MJBH-06MOR-11.00H/A
3	2	616071	04-451TC-04MJBH-06MOR-13.00H/A
4	4	618525	7/16-20 BLKHD LOCKNUT
5	2	621051	TREAD ADJUST CYL ASSY STS12
6	16	900129	3/8UNC X 1" HEX BOLT
7	8	900303	1/2UNC X 1 1/2 HEX BOLT
8	4	900391	3/4UNC X 1 1/2 FLT SOC CAP SCR
9	16	900395	1"UNC X 2 1/2 SOCKET CAP SCR
10	16	910101	1" UNC HEX JAM NUT
11	16	920002	3/8 SAE FLAT WASHER
12	16	920502	3/8 LOCK WASHER
13	12	920504	1/2 LOCK WASHER
14	1	361579	REAR TRD ADJ ACCESS PLT WLD
15	1	361576	FRT TREAD ADJ ACCESS PLT WLD
16	2	361581	TRD ADJ CYL PIVOT PIN, M/F
17	4	361583	TRD ADJ CYL SPACER, M/F
18	2	361582	TREAD ADJ CYL PIN, OUTER LEG
19	4	342719	TRD ADJ BRONZE BEARING, TAPPED
20	4	342721	TRD ADJ BRONZE BRG
21	4	342917	TREAD ADJ PLATE, STEEL STS10
22	2	361609	TRD ADJ ACCESS COVER, M/F STS10
23	4	900301	1/2UNC X 1" HEX BOLT

*NOTE: ITEMS 21,22,AND 23 ARE USED WITHOUT TREAD ADJUST.

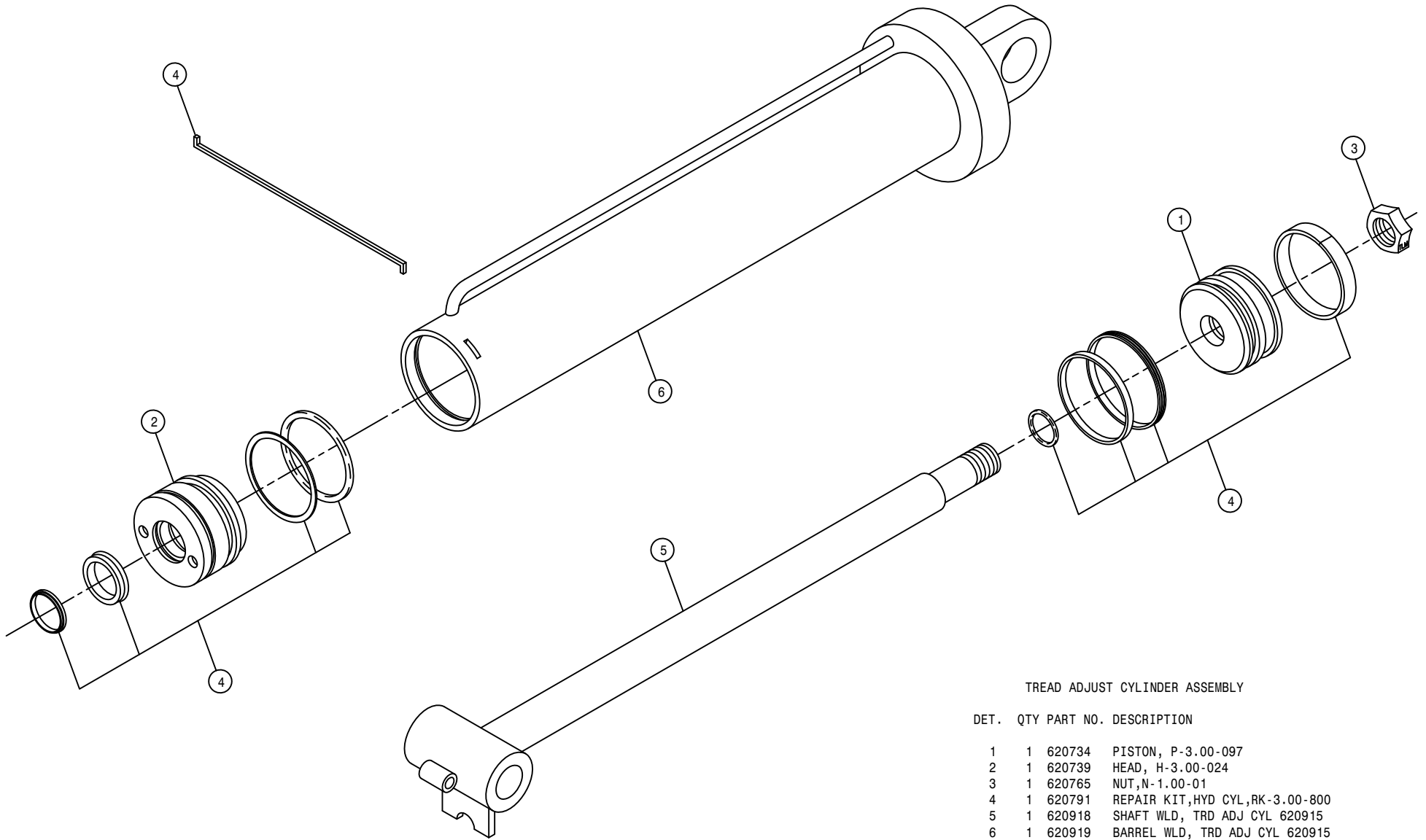

TREAD ADJUST CYLINDER ASSEMBLY

DET.	QTY	PART NO.	DESCRIPTION
	1	620734	PISTON, P-3.00-097
	1	620739	HEAD, H-3.00-024
	1	620765	NUT, N-1.00-01
	1	620791	REPAIR KIT, HYD CYL, RK-3.00-800
	1	620918	SHAFT WLD, TRD ADJ CYL 620915
	1	620919	BARREL WLD, TRD ADJ CYL 620915

NOTE: 1. 620915 - TREAD ADJUST CYLINDER ASSEMBLY ITEMS 1-6
 2. 621051 - TREAD ADJUST CYLINDER ASSEMBLY

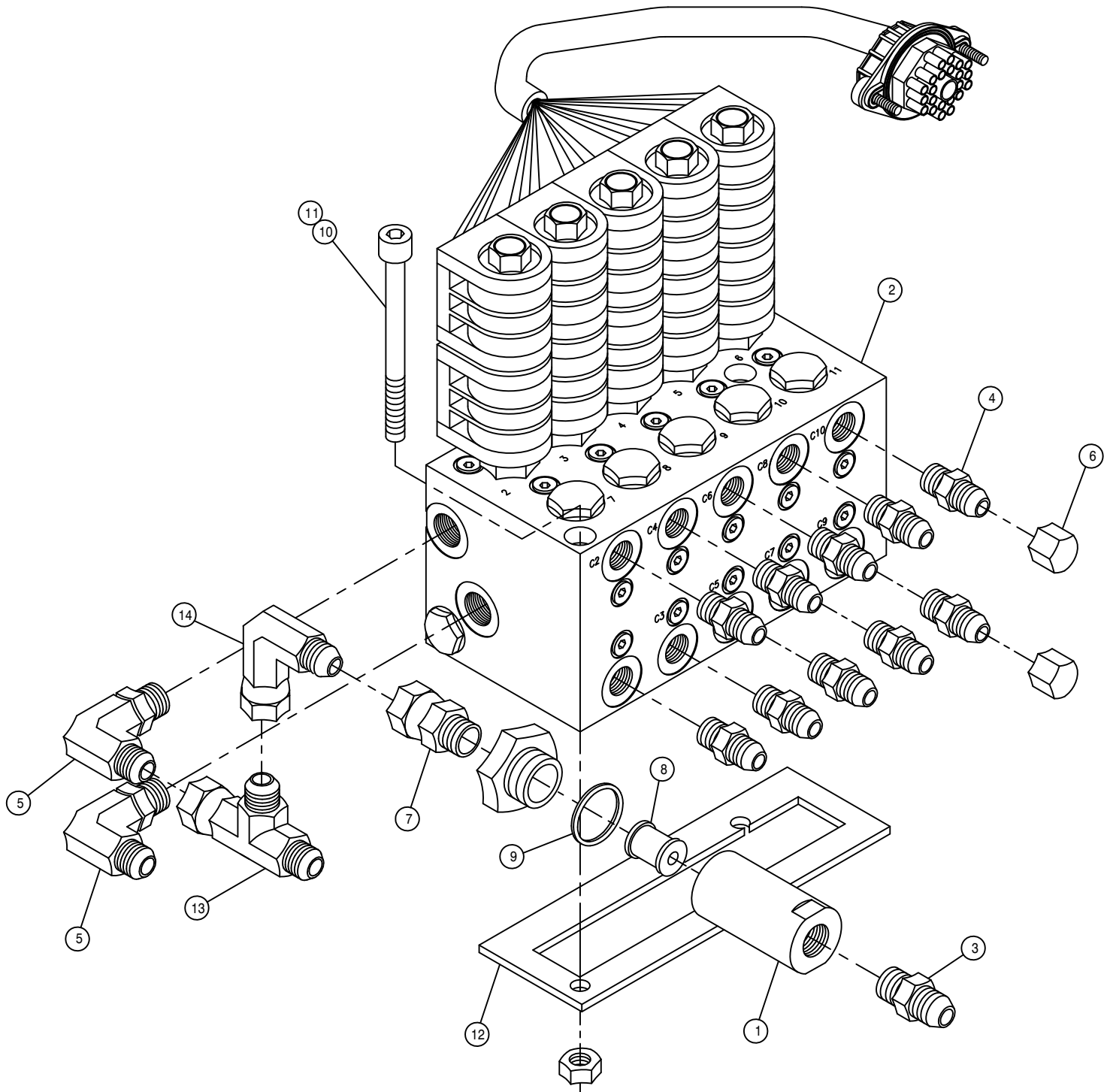

TREAD ADJUST HYD MANIFOLD ASSEMBLY

DET.	QTY	PART NO.	DESCRIPTION
1	1	605610	HYD FILTER, INLINE 90M 3/4FOR
2	1	606050	DELTA HYD MANIFOLD ASSY, 2704
3	1	611125	3/4MJIC-3/4MOR ADPTR
4	10	618126	9/16MJIC-9/16MOR ADPTR
5	2	618241	3/4MJIC-90-3/4MOR LBO
6	2	618531	9/16FJIC CAP NUT
7	1	618669	3/4FJIC SWIV-3/4MOR ADPTR
8	1	610459	90M FILTER & GASKET FOR610447
9	1	610462	GASKET FOR 610447 ARROW FILT
10	2	900145	3/8UNC X 5 SOCKET HD CAP SCR
11	2	914004	3/8UNC HEX STOVER NUT
12	1	342825	TREAD ADJ VLV SPACER
13	1	618451	3/4FJIC SW RUN TEE-3/4MJIC
14	1	618609	3/4MJIC-90-3/4FJIC SWIV LBO

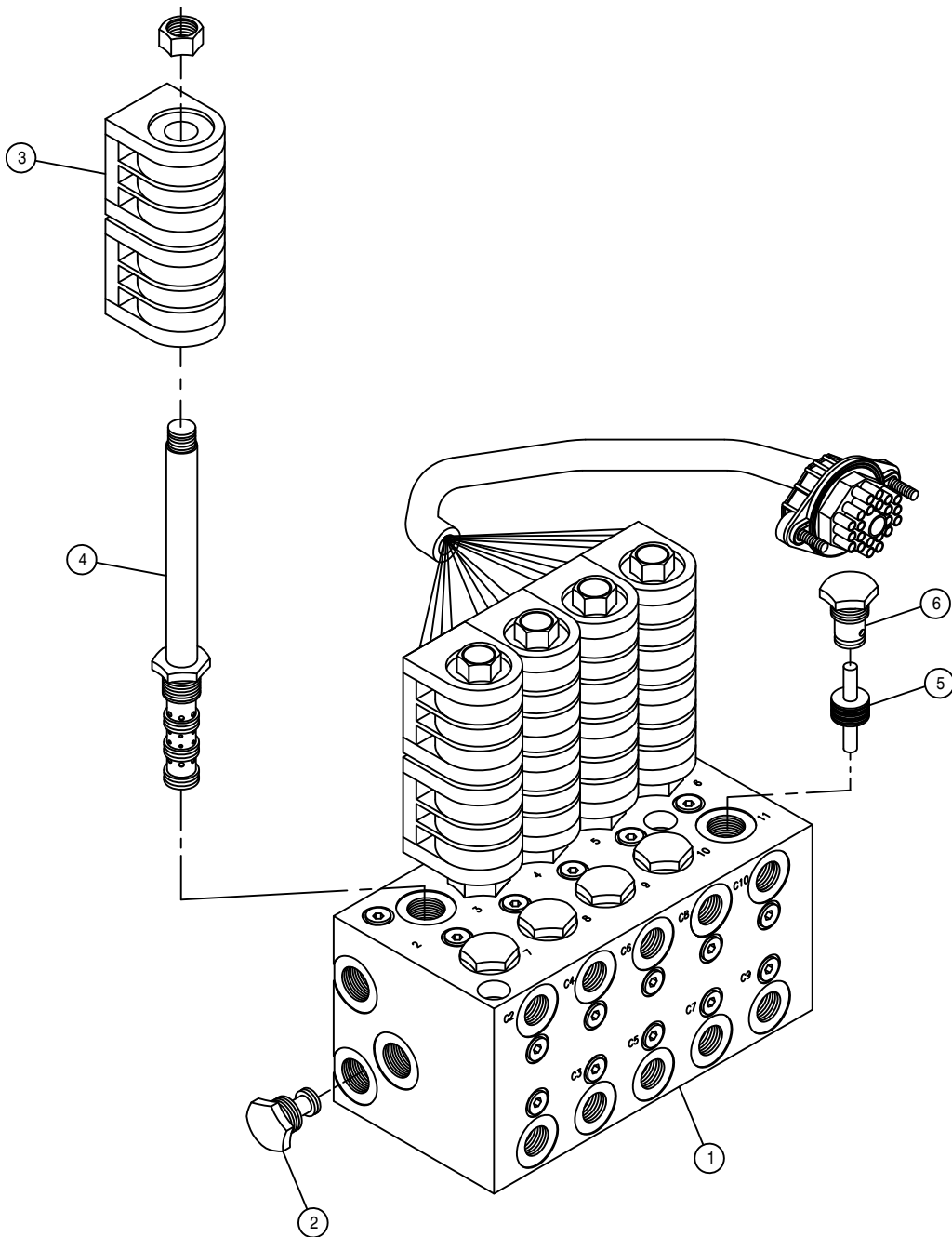

TREAD ADJUST HYD VALVE ASSEMBLY

DET.	QTY	PART NO.	DESCRIPTION
1	1	606050	DELTA HYD MANIFOLD ASSY, 2704
2	1	606073	CAVITY PLUG, DELTA VLV 606050
3	10	606056	COIL (63900502) FOR 606050/051
4	5	606057	SOLE VLV(DGS4M00)FOR 606050/51
5	5	606058	PISTON ASSY FOR 606050
6	10	606059	CHECK VALVE FOR 606050

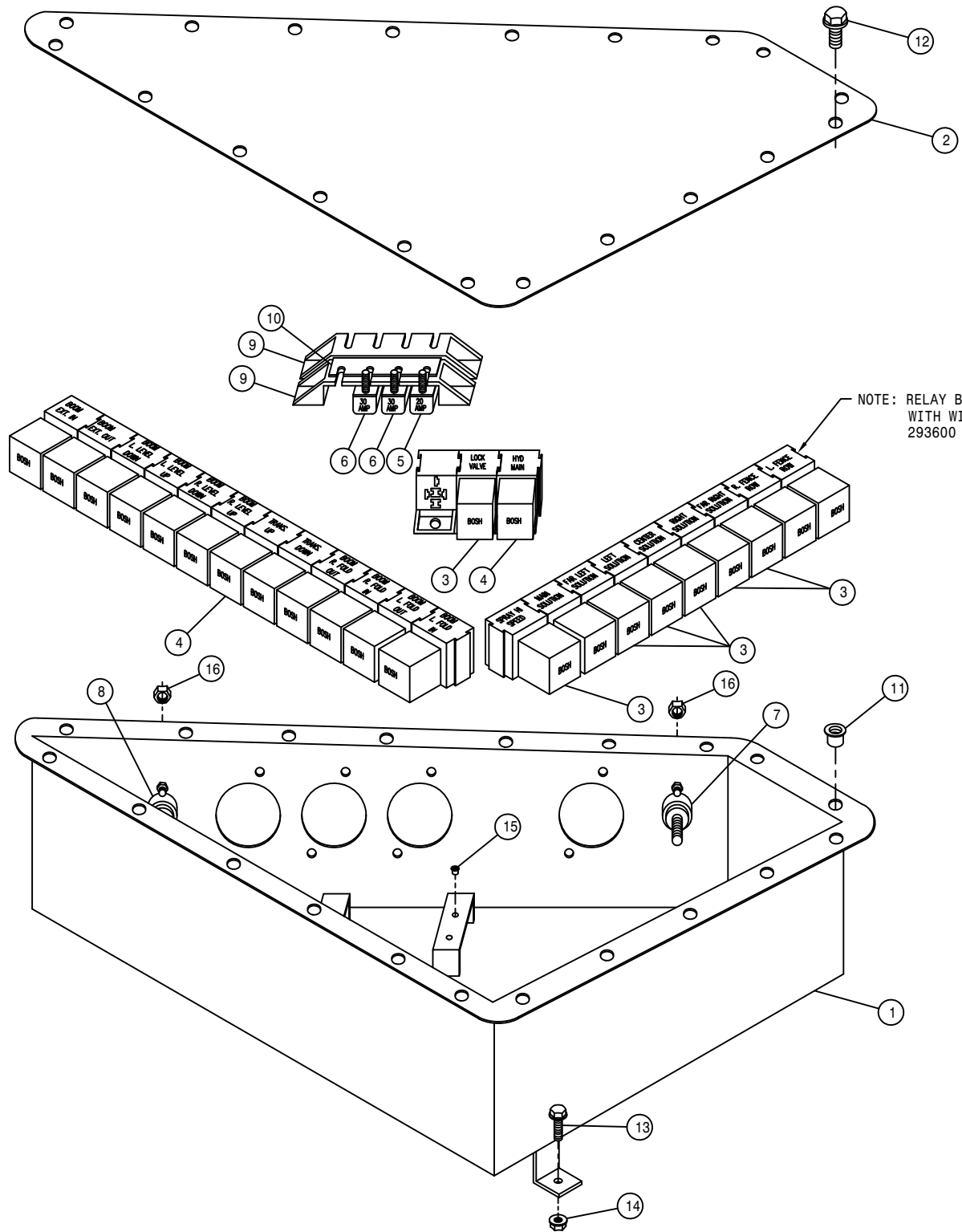

BOOM ELECTRICAL BOX ASSEMBLY

DET.	QTY	PART NO.	DESCRIPTION
	1	342830	BOOM ELECTRICAL BOX WLD
	1	342837	BOOM ELECTRICAL BOX COVER
	3	291752	RELAY, SPDT 12V 50A-NO 5-TERM
	4	16	291751 RELAY, SPST 12V 40A-NO 5-TERM
	5	1	291573 CIRCUIT BREAKER,20AMP W/O MT
	6	2	291574 CIRCUIT BREAKER,30AMP W/O MT
	7	1	291750 TERM BLOCK,RED,3/8-16 THRU
	8	1	291749 TERM BLOCK,BLACK,3/8-16 THRU
	9	2	291755 BREAKER MTG BRKT, 4-GANG NYLON
	10	1	291756 BUS BAR,4-GANG FOR 291755
	11	20	470086 1/4UNC NUTSERT .020-.100MATL
	12	20	470122 1/4UNC X 1/2 FLANGE HEX BOLT
	13	3	470118 1/4UNC X 3/4 FLANGE HEX BOLT
	14	3	470121 1/4UNC HEX FLANGE LOCK NUT
	15	14	470165 10-32 NUTSERT .020-.100 MATL
	16	2	910004 3/8UNC HEX NUT

NOTE: ALL RELAY BASES AND FUSE BLOCKS
COME WITH WIRE HARNESS
293626 - ENGINE BOX HARNESS

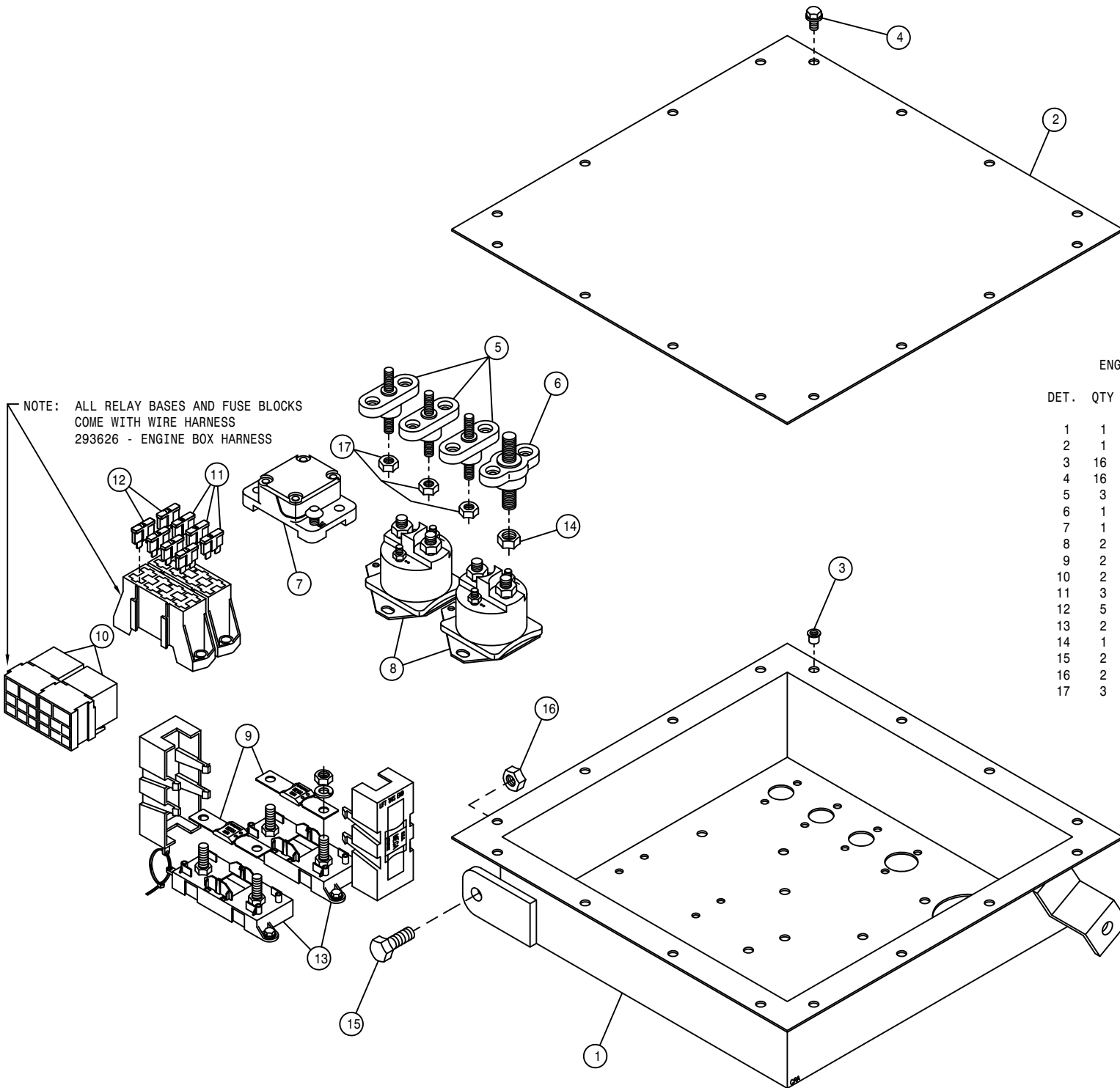

ENGINE ELECTRICAL BOX ASSEMBLY

DET.	QTY	PART NO.	DESCRIPTION
	1	342851	ENG ELECTRICAL BOX WLD
	1	342855	ENG ELECTRICAL BOX COVER
	16	470086	1/4UNC NUTSERT .020-.100MATL
	4	16	470122 1/4UNC X 1/2 FLANGE HEX BOLT
	5	3	291748 TERM BLOCK, BLACK, 1/4-20 THRU
	6	1	291750 TERM BLOCK, RED, 3/8-16 THRU
	7	1	291815 CIRCUIT BREAKER, 100 AMP BUSS
	8	2	291816 SOLENOID
	9	2	291813 125 AMP FUSE
	10	2	291751 RELAY, SPST 12V 40A-NO 5-TERM
	11	3	291545 10 AMP FUSE, 1/4" BLADE ATO/ATC
	12	5	291027 7.5 AMP FUSE, 1/4" BLADE ATO/ATC
	13	2	291814 FUSE HOLDER, HIGH AMP
	14	1	910004 3/8UNC HEX NUT
	15	2	900129 3/8UNC X 1" HEX BOLT
	16	2	914004 3/8UNC HEX STOVER NUT
	17	3	470121 1/4UNC HEX FLANGE LOCK NUT

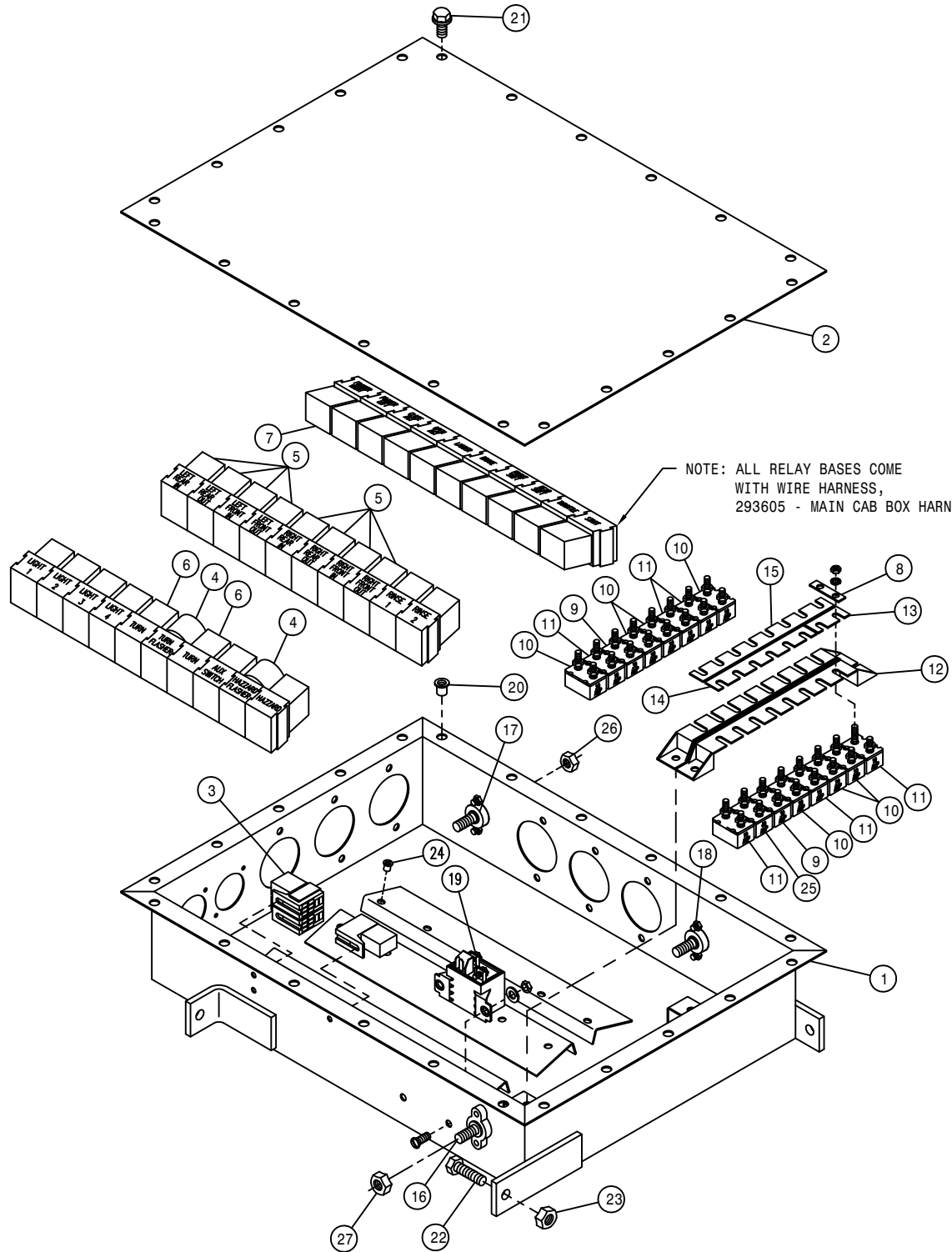

CAB ELECTRICAL BOX ASSEMBLY

DET.	QTY	PART NO.	DESCRIPTION
1	1	342841	CAB ELECTRICAL BOX WLD
2	1	342847	CAB ELECTRICAL BOX COVER
3	3	291781	MICRO RELAY, BOSCH 12V SPDT
4	2	291564	FLASHER, 12V 3-PIN ELECTRONIC
5	8	291698	RELAY, TYPE V4 12VDC 30A
6	2	291752	RELAY, SPDT 12V 50A-NO 5-TERM
7	18	291751	RELAY, SPDT 12V 40A-NO 5-TERM
8	1	291683	BUSS BAR, 2 GANG CIRCUIT BREAKR
9	2	291574	CIRCUIT BREAKER, 30AMP W/O MT
10	7	291573	CIRCUIT BREAKER, 20AMP W/O MT
11	6	291575	CIRCUIT BREAKER, 10AMP W/O MT
12	2	291757	BREAKER MTG BRKT, 8-GANG NYLON
13	1	291796	BUSS BAR, 2-GANG FOR 291757
14	1	291797	BUSS BAR, 6-GANG FOR 291757
15	1	291758	BUS BAR, 8-GANG FOR 291757
16	1	291748	TERM BLOCK, BLACK, 1/4-20 THRU
17	1	291749	TERM BLOCK, BLACK, 3/8-16 THRU
18	1	291750	TERM BLOCK, RED, 3/8-16 THRU
19	1	657371	RELAY, 12 VOLT 75 AMP
20	22	470086	1/4UNC NUTSERT .020-.100MATL
21	22	470122	1/4UNC X 1/2 FLANGE HEX BOLT
22	3	900129	3/8UNC X 1" HEX BOLT
23	3	914004	3/8UNC HEX STOVER NUT
24	16	470165	10-32 NUTSERT .020-.100 MATL
25	1	291584	CIRCUIT BREAKER, 40AMP W/O MT
26	2	910004	3/8UNC HEX NUT
27	1	470121	1/4UNC HEX FLANGE LOCK NUT

CAB ASSEMBLY

DET. QTY PART NO. DESCRIPTION

1	4	470175	10-32 HEX FLANGE LOCK NUT
2	4	903905	10-32X1 1/2 SLT RD HD MACH SCR
3	2	343101	CAB HINGE PIN, DRILLED STS12
4	2	291828	WORKLIGHT W/O BULB, CAB, STS12
5	2	291829	WORKLIGHT BULB FOR 291828, STS
6	1	343000	CAB, NEW HOLLAND FX DISCOVERY
7	32	485053	POP RIVET 3/16 X 3/8
8	4	472335	3/8UNC X 2" STUD BOLT
9	2	520064	HOSE CLAMP NO 64 STAINLESS
10	2	611125	3/4MJIC-3/4MOR ADPTR
11	1	618241	3/4MJIC-90-3/4MOR LBO
12	1	618443	3/4MJIC-90-3/4MOR EX LG LBO
13	1	657435	FILTER BOX W/FILTERS STS12
14	1	749321	STEERING CONTROL MTR 14.1CI
15	6	900002	1/4UNC X 3/4 HEX BOLT
16	1	657437	CHARCOAL FILTER FOR 657435
17	4	910004	3/8UNC HEX NUT
18	1	343004	WINDSHIELD, STS12 CAB 2000
19	4	914000	1/4UNC HEX STOVER NUT
20	4	920502	3/8 LOCK WASHER
21	2	343134	REAR CAB MT WLD, STS10
22	1	343019	CAB STABILIZER MT WLD
23	1	343022	REAR CAB COVER PLATE
24	1	343023	STEERING MTR SPACER STS12
25	1	343024	AIR DUCT HOSE, 4" X 5" LG CLLPSD
26	1	657436	PANEL FILTER FOR 657435
27	2	470121	1/4UNC HEX FLANGE LOCK NUT
28	2	910009	1/2UNF HEX NUT
29	4	520080	HOSE CLAMP NO 10 STAINLESS
30	1	601465	HOSE, 5/8 X 19 HEATER
31	1	601466	HOSE, 5/8 X 21 HEATER
32	3	343027	DIMMER SWITCH MT PLT
33	1	343026	DIMMER SWITCH MT WLD
34	1	290412	DIMMER SWITCH
35	1	657442	A/C HOSE, 06-06F90-06M90-33"
36	1	657445	A/C HOSE, 08-10F90-10M90-35"
37	1	343072	CAB STABILIZER ROD
38	1	343025	CAB STEP PLATE
39	2	914004	3/8UNC HEX STOVER NUT
40	2	900129	3/8UNC X 1" HEX BOLT
41	2	900267	1/2UNC X 2" HEX BOLT
42	2	900274	1/2UNC X 4" HEX BOLT
43	4	914008	1/2UNC HEX STOVER NUT
44	2	473976	ROD END, .50B, .50-20UNF RH MALE
45	2	473775	12MM-1.75 X 30MM HEX BOLT
46	2	473784	12MM LOCK WASHER
47	6	470154	CABLE TIE, 11.75" BLK PLASTIC
48	2	601552	HOSE, 1/2 X 4 CLEAR VINYL
49	2	619014	1/2" HOSE MENDER
50	2	657451	A/C KAZOO, 1/2" X 2" LONG
51	3	470349	GROMMET, .875ID .125GW 1.250GD
52	1	291214	ANTENNA
53	1	343118	A/C FILTER ELEMENT, CAB STS12

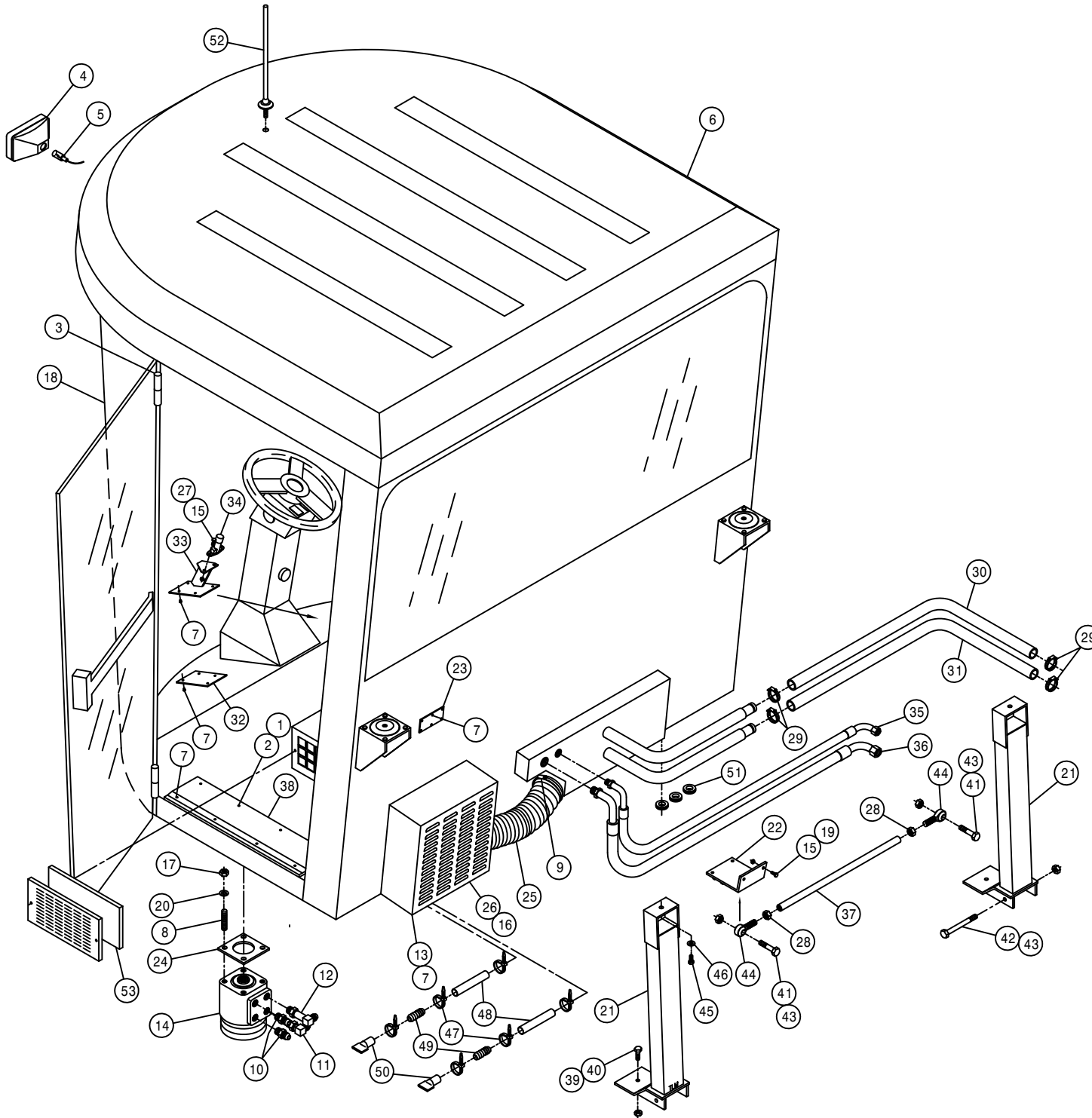

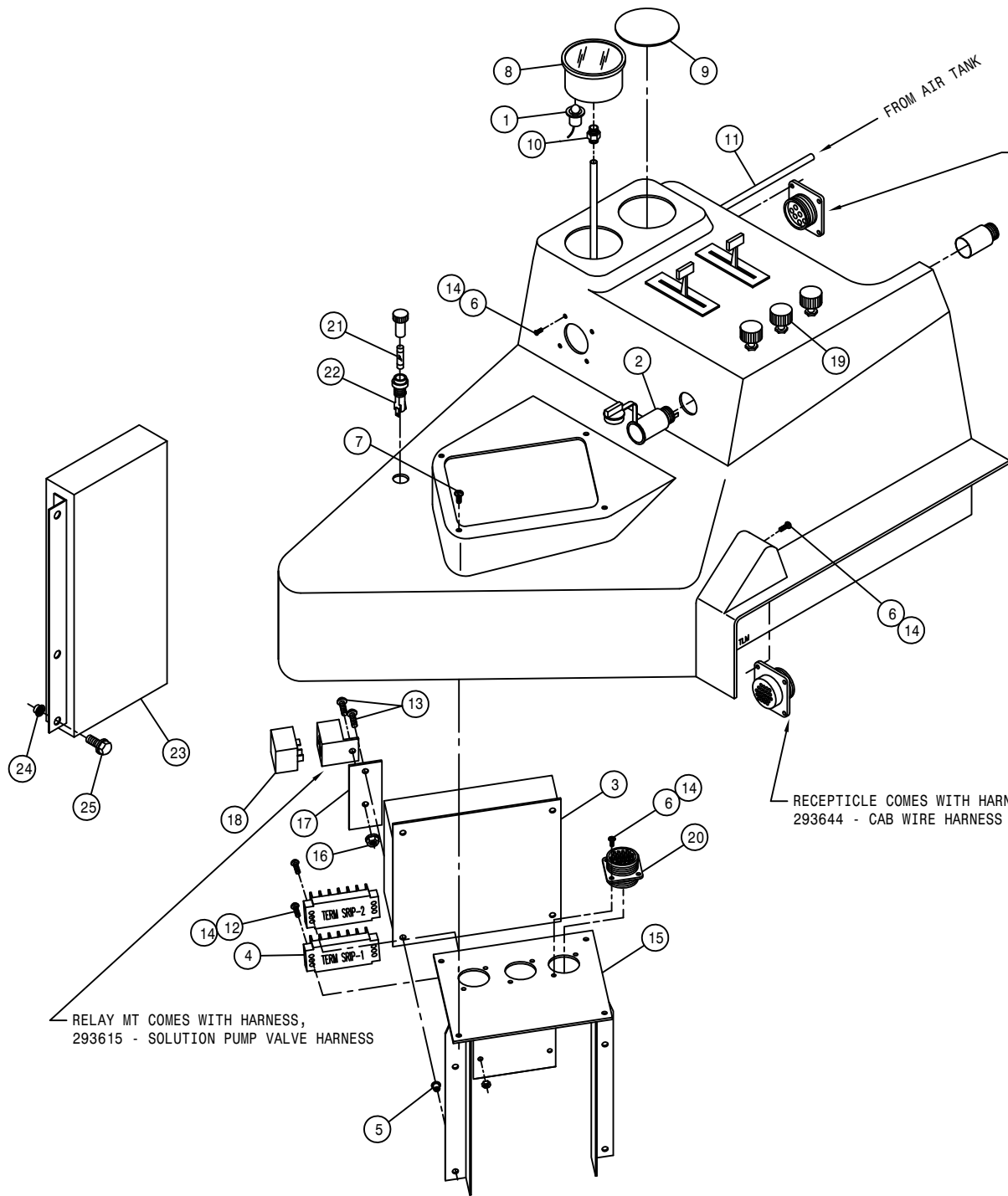

RECEPTICLE COMES WITH HARNESS,
293610 - DIAGNOSTIC READ HARNESS

RECEPTICLE COMES WITH HARNESS,
293644 - CAB WIRE HARNESS

RELAY MT COMES WITH HARNESS,
293615 - SOLUTION PUMP VALVE HARNESS

HEATER CONTROL PANEL ASSEMBLY

DET.	QTY	PART NO.	DESCRIPTION
	1	291612	LIGHT KIT FOR 2" GAUGE
	2	291648	POWER POINT RECEPTACLE
	3	291787	INPUT MODULE, ATI
	4	293093	TERMINAL BLOCK 6 POS - 2 ROW
	5	470165	10-32 NUTSERT .020-.100 MATL
	6	14 473989	6-32 X 3/4 BUTTON SOC CAP SCR
	7	473990	8-15 X 3/4 PHIL PAN SMS TY-A
	8	701311	AIR PRESS GAUGE, 150PSI, PNL MT
	9	701312	GAUGE BLANK
	10	711038	1/8FNPT-1/4 NYL TUBE FTG
	11	601486	HOSE, 1/4 X 215 AIR
	12	4 903814	6-32 X 3/4 SLT RD HD MACH SCR
	13	5 903883	10-32 X 1/2 SLT RDHD MACH SCR
	14	18 910022	6-32 HEX NUT
	15	1 343142	CONSOLE COVER WLD, CAB STSC
	16	1 470175	10-32 HEX FLANGE LOCK NUT
	17	1 343067	RELAY BRKT
	18	1 291752	RELAY, SPDT 12V 50A-NO 5-TERM
	19	1 343114	SWITCH, CAB FAN STS12 2000
	20	3 291841	AMP RECEPTCL, 17-16 THRU, SQ FLG
	21	1 291602	FUSE 10 AMP
	22	1 298011	FUSE HOLDER
	23	1 293374	LS CTRL 6L CABLE BOX ASSY
	24	2 470086	1/4UNC NUTSERT .020-.100MATL
	25	2 470122	1/4UNC X 1/2 FLANGE HEX BOLT

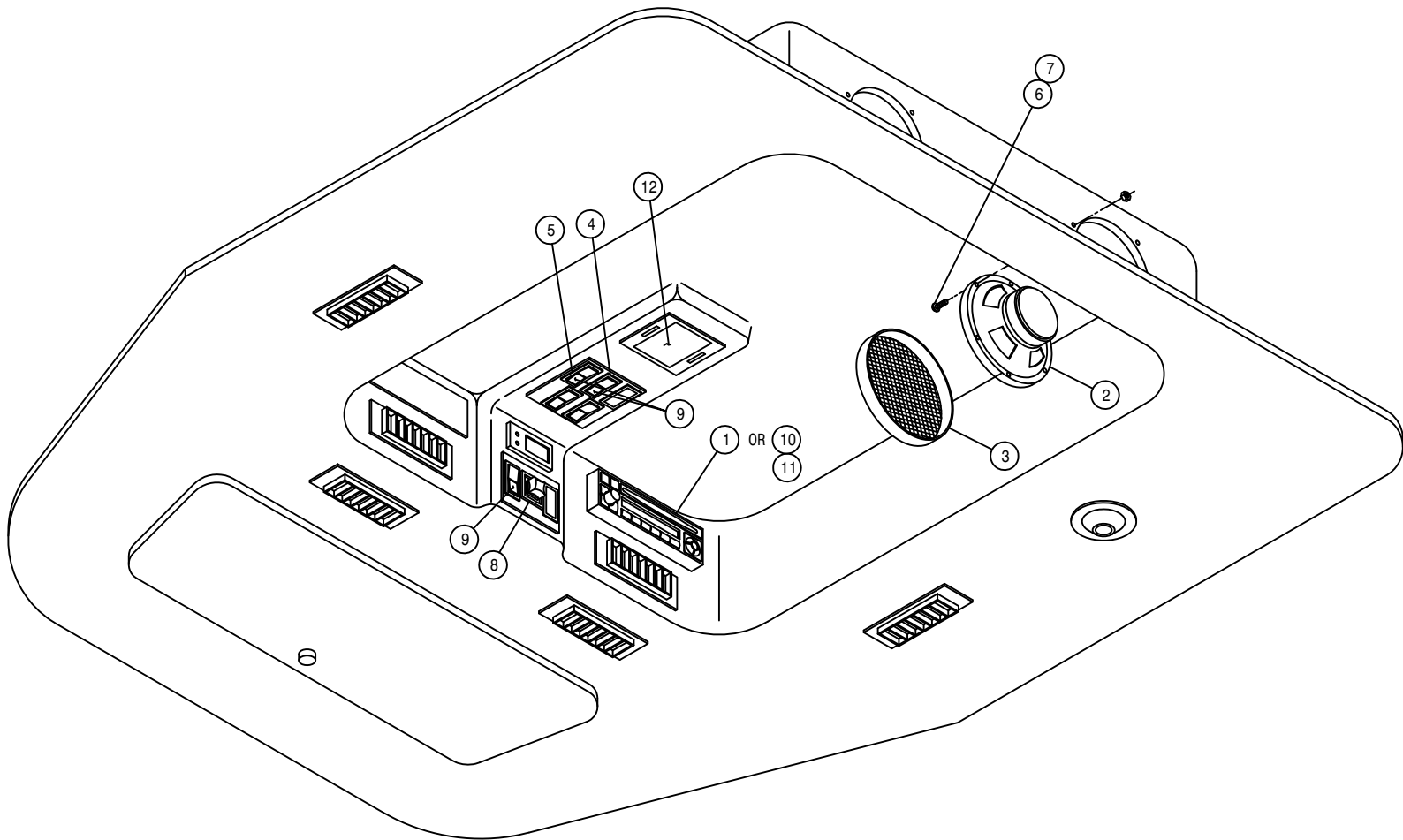

HEADLINER ASSEMBLY

DET. QTY PART NO. DESCRIPTION

DET.	QTY	PART NO.	DESCRIPTION	
1	1	291212	RADIO	94
2	2	291219	SPEAKER, 5 1/4"RD	
3	2	291319	SPEAKER GRILLE, ROUND SNAP ON	
4	1	291627	SWITCH, 2P(ON)OFF(ON) 511-058	
5	1	291775	SWITCH, 511-172	
6	6	903812	6-32 X 1/2 SLT RD HD MACH SCR	
7	6	910022	6-32 HEX NUT	
8	1	291798	MIRROR SWITCH FOR 470316	
9	3	291628	LENS, GREEN 596-650	
10	1	291835	RADIO, AM/FM/CD/WB CRC-5320	
11	1	291836	WIRE HARNESS FOR 291835 RADIO	
12	1	343123	DOME LIGHT, CAB STS	

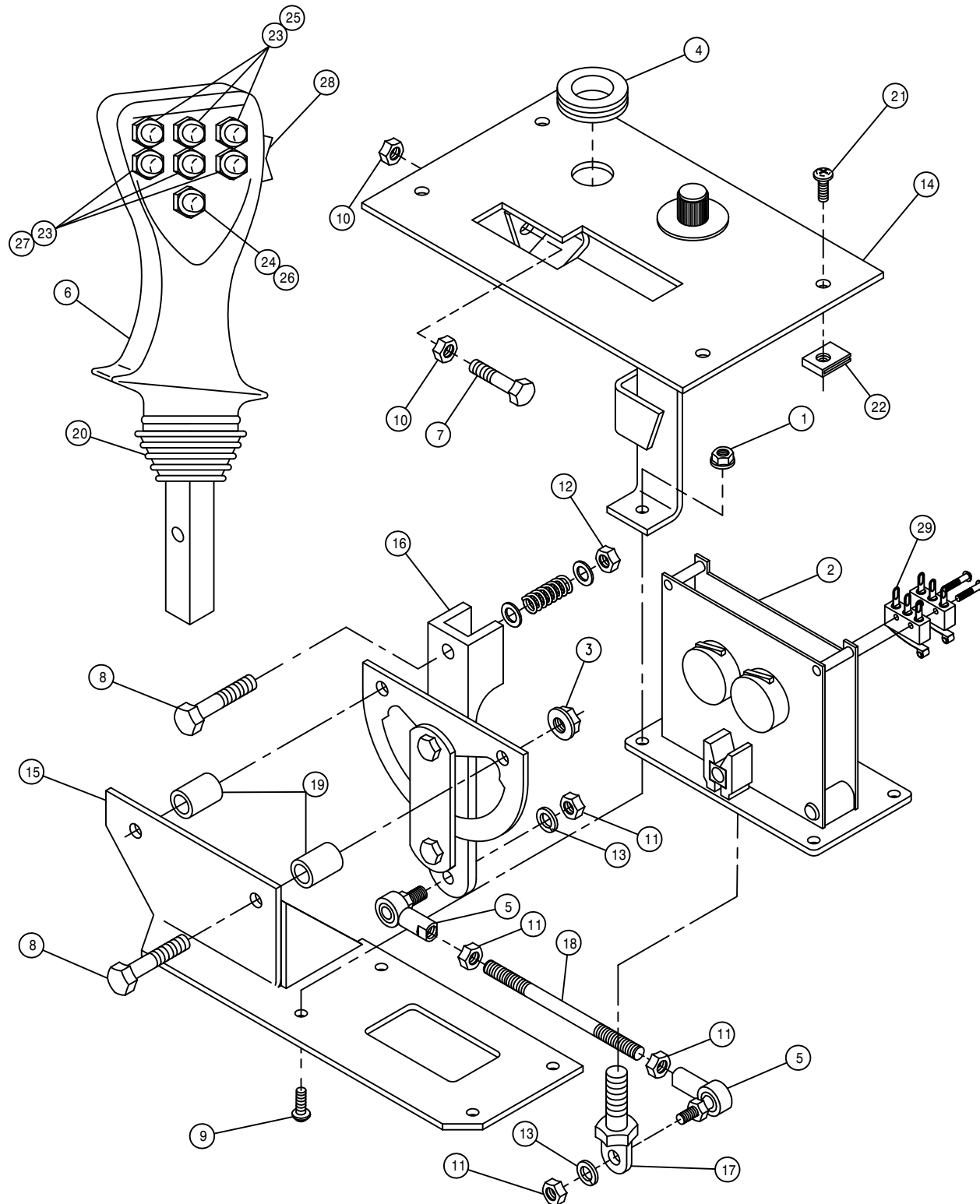

HYDROSTATIC CONTROL LEVER ASSEMBLY

DET.	QTY	PART NO.	DESCRIPTION
	1	4	169028 10-24 HEX FLANGE LOCK NUT
	2	1	291760 CONTROL HANDLE & POTENTIOMETER
	3	2	470121 1/4UNC HEX FLANGE LOCK NUT
	4	1	470296 GROMMET, .750ID .062GW 1.062GD
	5	2	473918 BALL JOINT 1/4 28 FEM STUDED
	6	1	785085 FASSE CTRL HANDLE, C15L4'14TRM
	7	2	900003 1/4UNC X 1" HEX BOLT
	8	3	900005 1/4UNC X 1 1/2 HEX BOLT
	9	4	903888 10-24 X 3/4 SLT RDHD MACH SCR
	10	4	910000 1/4UNC HEX NUT
	11	4	910001 1/4UNF HEX NUT
	12	1	914000 1/4UNC HEX STOVER NUT
	13	2	920500 1/4 LOCK WASHER
	14	1	343031 HYDRO LEVER MT PLT WLD
	15	1	343037 HYDRO LEVER MT WLD
	16	1	343040 HYDST CTRL LEVER STS12
	17	1	343041 HYDRO LINKAGE BOLT WLD
	18	1	343043 HYDRO LINKAGE ROD
	19	2	343044 HYDRO LEVER SPACER
	20	1	785081 BELLOW,FASSE CTRL HANDLE785080
	21	4	473990 8-15 X 3/4 PHIL PAN SMS TY-A
	22	4	470172 # 8 SPEED NUT
	23	6	291793 SWITCH,PB DPTD MOM MICRO
	24	1	291794 SWITCH,PB SPDT STAT MICRO
	25	3	291651 SWITCH BOOT, GRAY -FOR 291650
	26	1	291818 SWITCH BOOT 15/32 GREEN
	27	3	291652 SWITCH BOOT, RED -FOR 291650
	28	1	291826 SWITCH, SPDT RCKR 3P STAT
	29	4	291827 MICRO SWITCH FOR 291760

SWITCH PANEL ASSEMBLY

DET.	QTY	PART NO.	DESCRIPTION
1	1	291819	SWITCH PANEL, 14 POS W/SW STS10
2	1	291622	SWITCH, 1P ON/OFF 511-003
3	3	291628	LENS, GREEN 596-650
4	1	291625	SWITCH, 2P ON/ON 511-108
5	7	291627	SWITCH, 2P (ON)/OFF (ON) 511-058
6	1	291671	SWITCH, 2P OFF/ONA/ONAB 511-138
7	2	291672	SWITCH, 1P ON/OFF/ON 511-149
8	1	293645	PWR PORT PIGTAIL ASSY, STS 02
9	1	291775	SWITCH, 511-172
10	7	291776	BLANK COVER
11	1	291832	AMP RECEPTCL, 17-3 STD, SQ FLG
12	1	291754	AMP RECEPTACLE CAP, 17-SHELL
13	18	473989	6-32 X 3/4 BUTTON SOC CAP SCR
14	18	910022	6-32 HEX NUT
15	1	291773	WARNING PANEL, 6 POSITION
16	1	321021	IGN SWITCH, NON-SEALED
17	2	291782	RELAY BASE, 5-PIN MICRO, PNL MT
18	2	291781	MICRO RELAY, BOSCH 12V SPDT
19	1	343047	RELAY BASE MT BRKT
20	2	920510	#10 LOCK WASHER
21	2	910026	10-24 HEX NUT
22	2	472199	10-24 X 1/2 RD HD MACH SCR

*NOTE: FOR TREAD ADJUST USE ITEMS 3,5, AND 7.

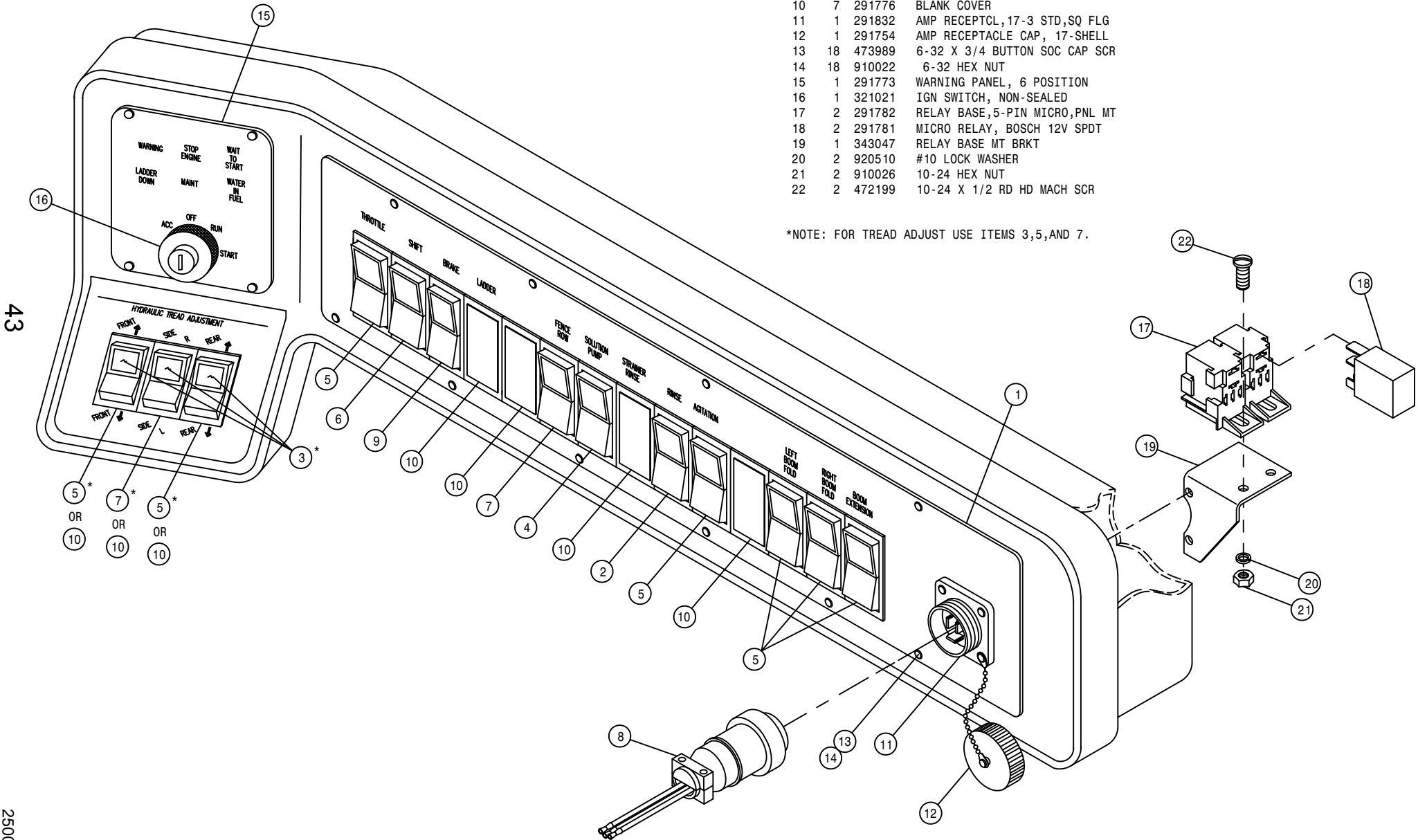

43

250043

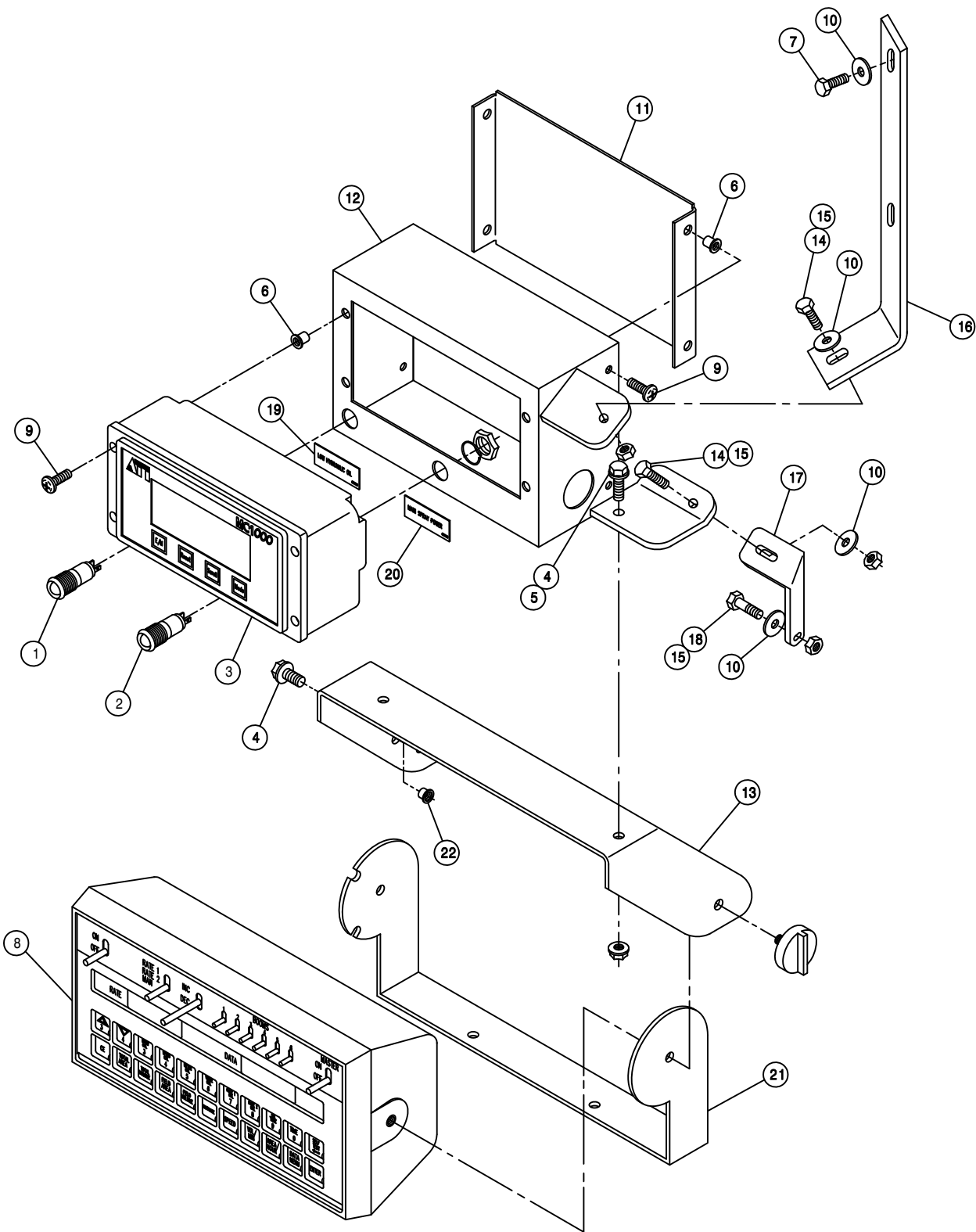

ATI MC1000 CONTROL BOX ASSEMBLY

DET.	QTY	PART NO.	DESCRIPTION
	1	291740	RED LED IND LIGHT,12V 10MM
	1	291741	GREEN LED IND LIGHT,12V 10MM
	1	291761	MESSAGE CENTER, ATI MC1000
	3	470118	1/4UNC X 3/4 FLANGE HEX BOLT
	2	470121	1/4UNC HEX FLANGE LOCK NUT
	8	470165	10-32 NUTSERT .020-.100 MATL
	2	473787	6MM-1.00 X 25MM HEX BOLT
	1	690810	CONSOLE, RAVEN 450 W/GPS PORT
	8	903710	10-32X5/8 PHIL PANHD MACH SCR
	5	920000	1/4 SAE FLAT WASHER
	1	343058	ATI MC1000 CTRL BOX COVER
	1	343053	ATI MC1000 CTRL BOX WLD
	1	343144	MONITOR MT BRKT, STS COMBO
	2	900003	1/4UNC X 1" HEX BOLT
	3	914000	1/4UNC HEX STOVER NUT
	1	343060	ATI MC1000 CTRL BOX UPR SUPP
	1	343061	ATI MC1000 CTRL BOX LWR SUPP
	1	900004	1/4UNC X 1 1/4 HEX BOLT
	1	650109	DECAL, LOW HYDRAULIC OIL
	1	650108	DECAL, MAIN SPRAY POWER
	1	343145	DEPTH CMD BOX BRKT, STS COMBO
	1	470086	1/4UNC NUTSERT .020-.100MATL

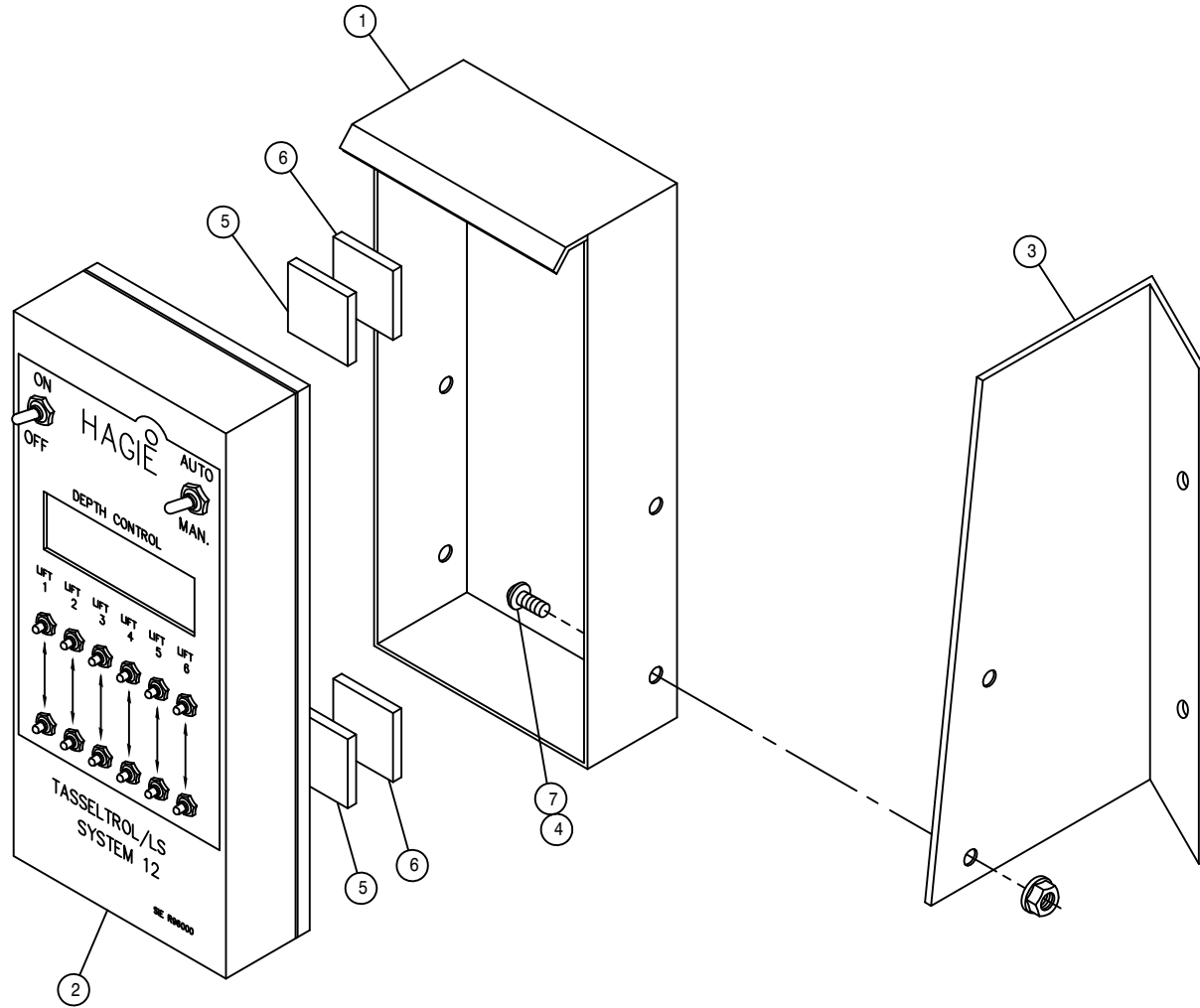

LS CONTROL DISPLAY ASSEMBLY

DET. QTY PART NO. DESCRIPTION

1	1	002903	LS CTRL 6L DISPLAY MT
2	1	293373	LS CTRL 6L DISPLAY BOX ASSY
3	1	343146	DETASSELER CTRL BOX MT, STSC
4	2	470121	1/4UNC HEX FLANGE LOCK NUT
5	2	471100	DUAL LOCK, 1.00 X 1.00 SJ3541
6	2	471101	DUAL LOCK, 1.00 X 1.00 SJ3542
7	2	903708	1/4UNC X1/2 PHIL PNHD MACHSCR

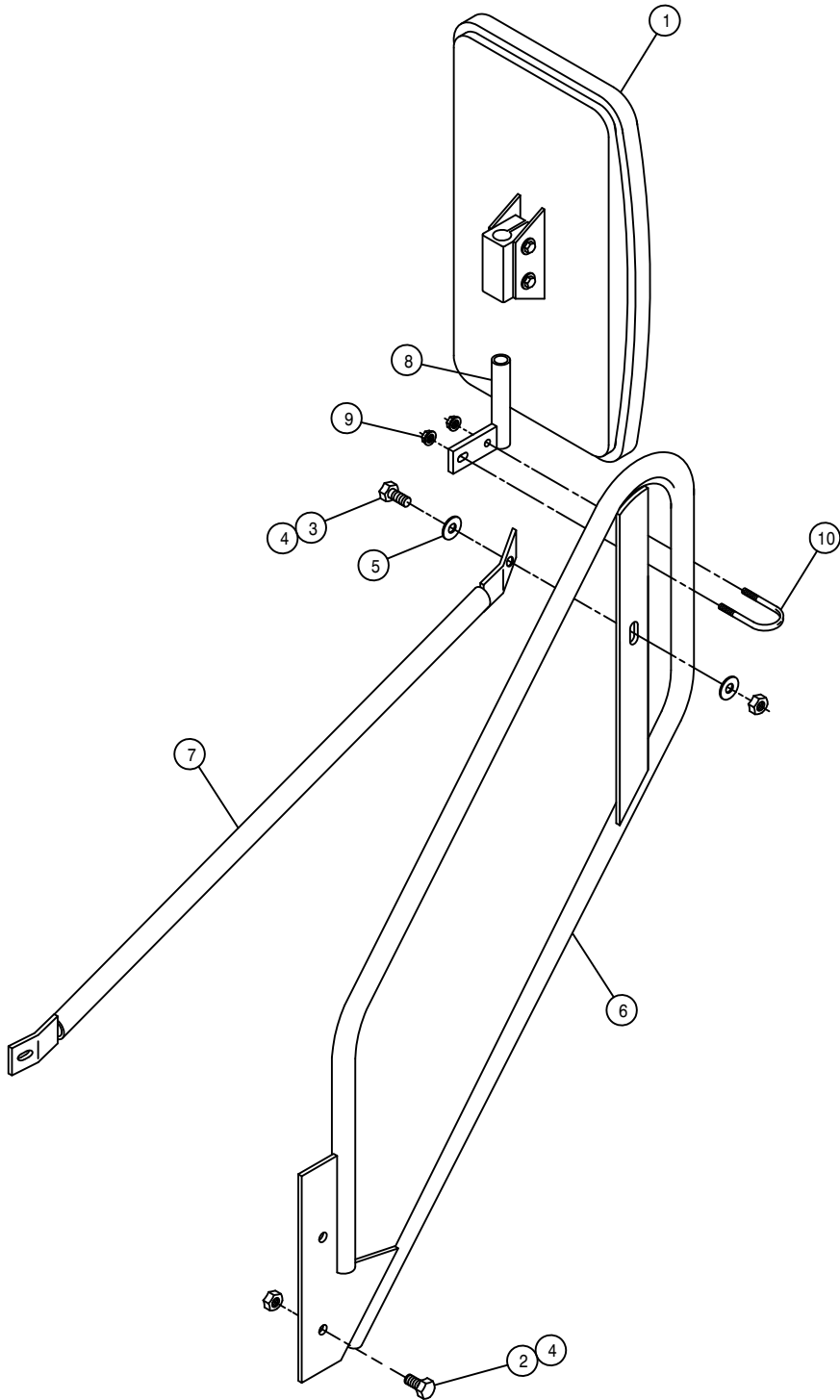

RH MIRROR ASSEMBLY

DET.	QTY	PART NO.	DESCRIPTION	
1	1	470348	MIRROR	STS10
2	1	900129	3/8UNC X 1" HEX BOLT	
3	1	900128	3/8UNC X 3/4 HEX BOLT	
4	2	914004	3/8UNC HEX STOVER NUT	
5	2	920002	3/8 SAE FLAT WASHER	
6	1	343073	MIRROR MT TUBE WLD	
7	1	343077	RH MIRROR BRACE TUBE BRKT WLD	
8	1	343150	MIRROR MT WLD,	STS10 02
9	2	470121	1/4UNC HEX FLANGE LOCK NUT	
10	1	472280	1/4UNC-3/4ID-1 1/2 U-BOLT	

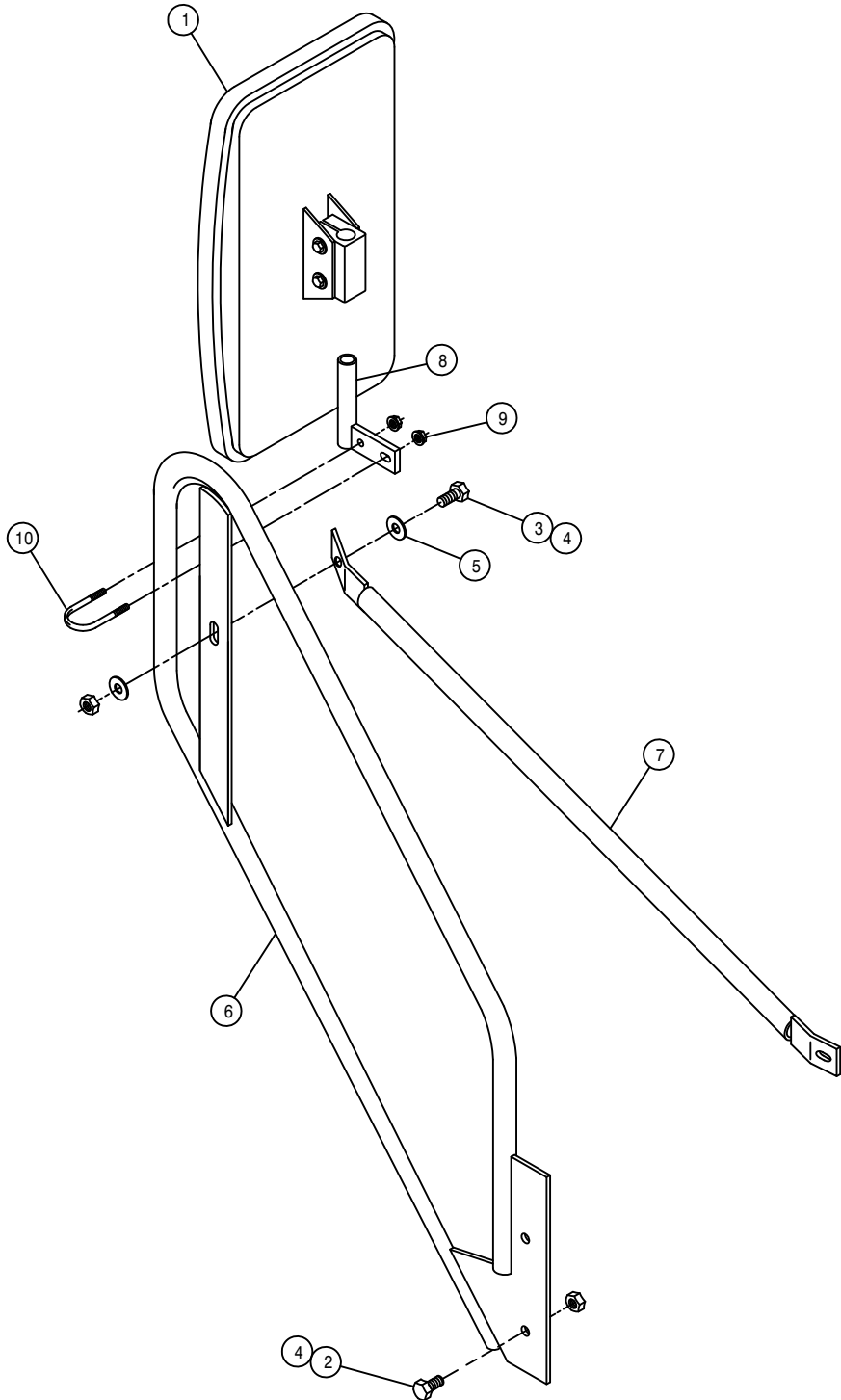

LH MIRROR ASSEMBLY

DET. QTY PART NO. DESCRIPTION

DET.	QTY	PART NO.	DESCRIPTION	
1	1	470348	MIRROR	STS10
2	1	900129	3/8UNC X 1" HEX BOLT	
3	1	900128	3/8UNC X 3/4 HEX BOLT	
4	2	914004	3/8UNC HEX STOVER NUT	
5	2	920002	3/8 SAE FLAT WASHER	
6	1	343073	MIRROR MT TUBE WLD	
7	1	343078	LH MIRROR BRACE TUBE BRKT WLD	
8	1	343150	MIRROR MT WLD,	STS10 02
9	2	470121	1/4UNC HEX FLANGE LOCK NUT	
10	1	472280	1/4UNC-3/4ID-1 1/2 U-BOLT	

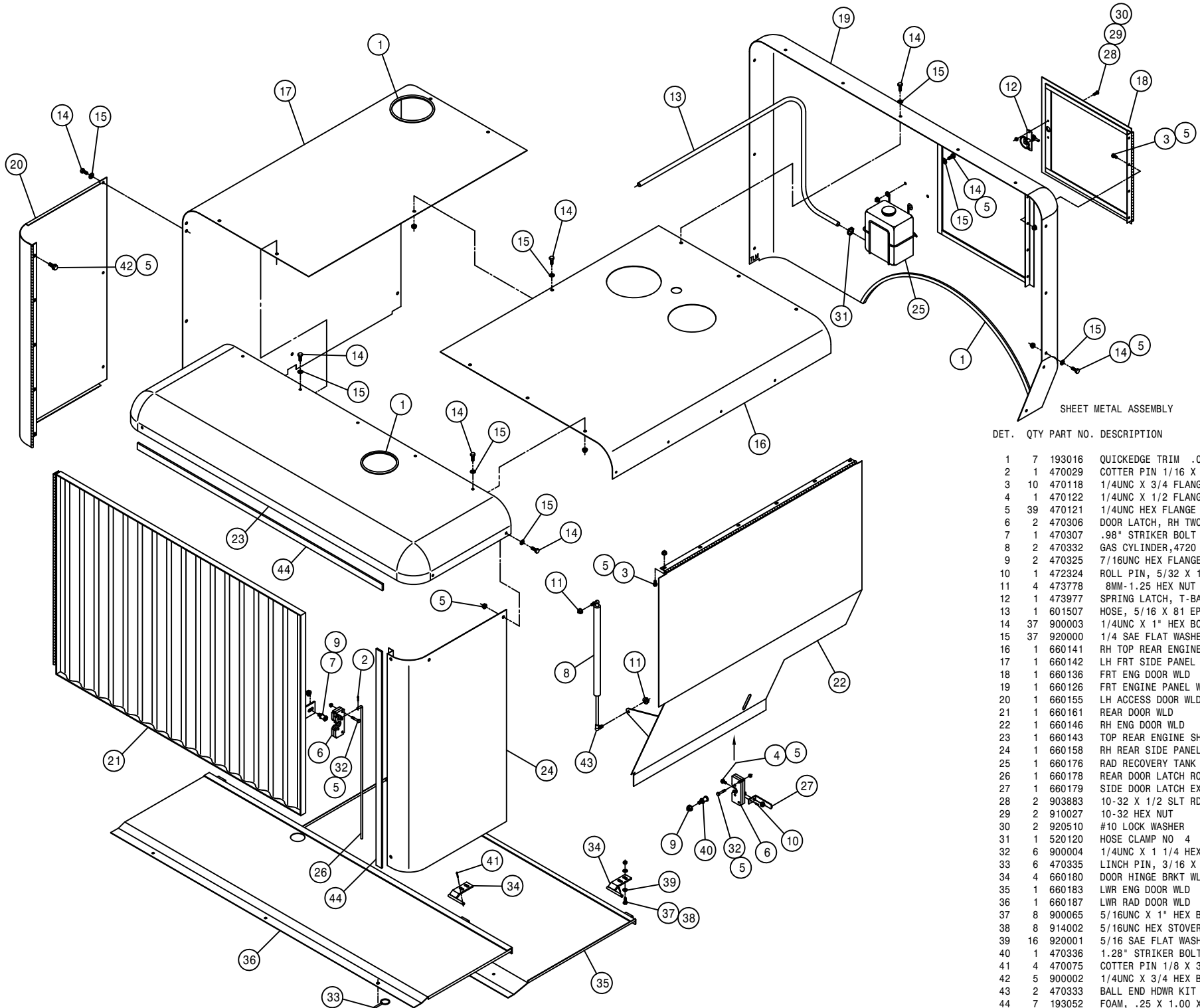

SHEET METAL ASSEMBLY

DET.	QTY	PART NO.	DESCRIPTION
1	7	193016	QUICKEDGE TRIM .060 TO .170
2	1	470029	COTTER PIN 1/16 X 1/2
3	10	470118	1/4UNC X 3/4 FLANGE HEX BOLT
4	1	470122	1/4UNC X 1/2 FLANGE HEX BOLT
5	39	470121	1/4UNC HEX FLANGE LOCK NUT
6	2	470306	DOOR LATCH, RH TWO-ROTOR
7	1	470307	.98" STRIKER BOLT FOR 470306
8	2	470332	GAS CYLINDER,4720 9.23 STROKE
9	2	470325	7/16UNC HEX FLANGE LOCK NUT
10	1	472324	ROLL PIN, 5/32 X 1/2 LG
11	4	473778	8MM-1.25 HEX NUT
12	1	473977	SPRING LATCH, T-BAR
13	1	601507	HOSE, 5/16 X 81 EPDM
14	37	900003	1/4UNC X 1" HEX BOLT
15	37	920000	1/4 SAE FLAT WASHER
16	1	660141	RH TOP REAR ENGINE SHIELD
17	1	660142	LH FRT SIDE PANEL
18	1	660136	FRT ENG DOOR WLD
19	1	660126	FRT ENGINE PANEL WLD
20	1	660155	LH ACCESS DOOR WLD
21	1	660161	REAR DOOR WLD
22	1	660146	RH ENG DOOR WLD
23	1	660143	TOP REAR ENGINE SHIELD WLD
24	1	660158	RH REAR SIDE PANEL WLD
25	1	660176	RAD RECOVERY TANK AND MTG WLD
26	1	660178	REAR DOOR LATCH ROD
27	1	660179	SIDE DOOR LATCH EXT
28	2	903883	10-32 X 1/2 SLT RDHD MACH SCR
29	2	910027	10-32 HEX NUT
30	2	920510	#10 LOCK WASHER
31	1	520120	HOSE CLAMP NO 4 STAINLESS
32	6	900004	1/4UNC X 1 1/4 HEX BOLT
33	6	470335	LINCH PIN, 3/16 X 1 1/4 GRIP
34	4	660180	DOOR HINGE BRKT WLD STS12 2001
35	1	660183	LWR ENG DOOR WLD STS12 2001
36	1	660187	LWR RAD DOOR WLD STS12 2001
37	8	900065	5/16UNC X 1" HEX BOLT
38	8	914002	5/16UNC HEX STOVER NUT
39	16	920001	5/16 SAE FLAT WASHER
40	1	470336	1.28" STRIKER BOLT FOR 470306
41	4	470075	COTTER PIN 1/8 X 3/4
42	5	900002	1/4UNC X 3/4 HEX BOLT
43	2	470333	BALL END HDWR KIT FOR 470332
44	7	193052	FOAM, .25 X 1.00 X 50 FT W/PSA

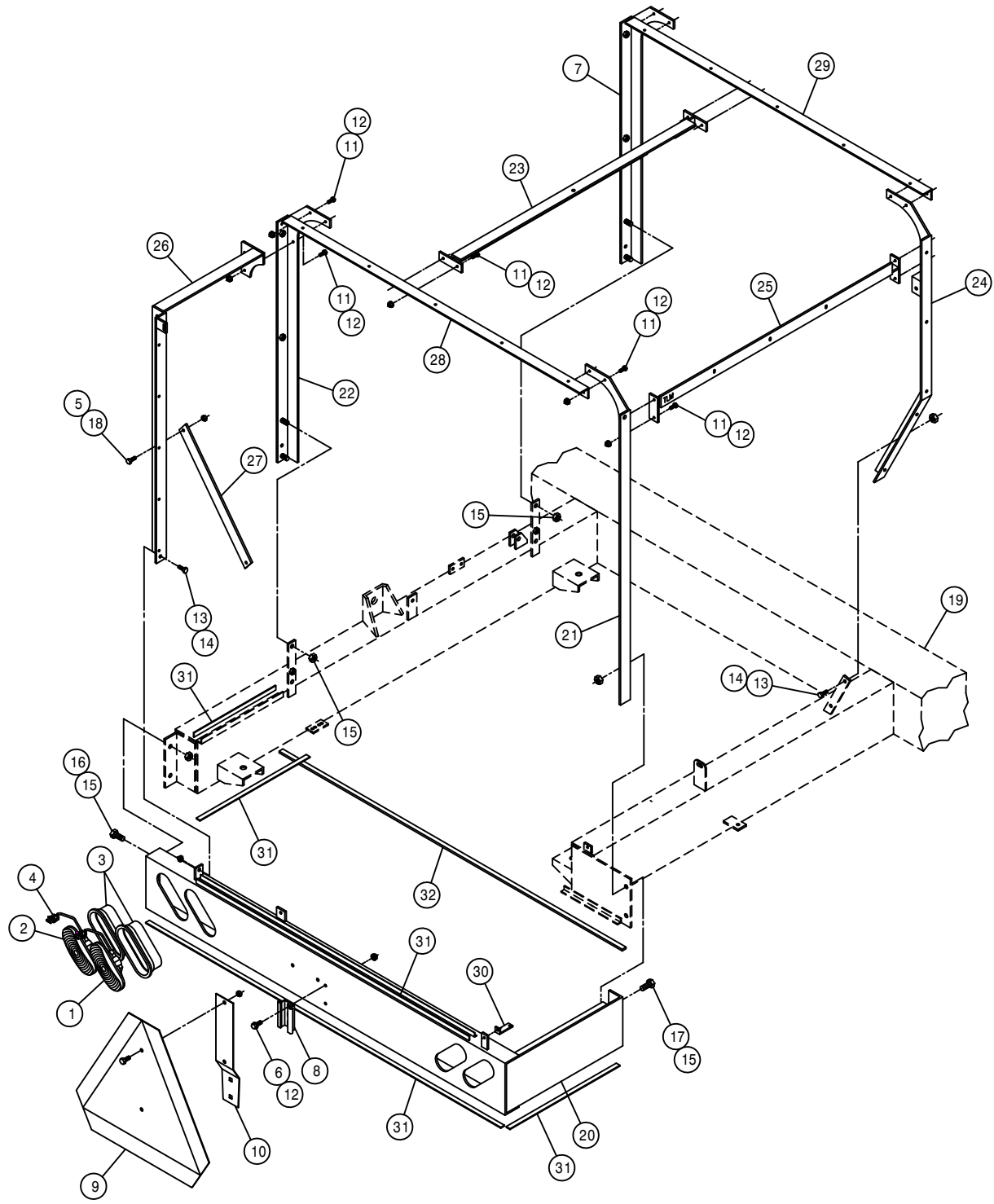

SHEET METAL FRAME ASSEMBLY

DET.	QTY	PART NO.	DESCRIPTION
	2	291694	RED LAMP, 6 1/2" OVAL 12.8V
	2	291695	YELLOW LAMP, 6 1/2" OVAL 12.8V
	4	291697	RUBBER MT FOR 6 1/2" OVAL LAMP
	4	293515	3-WIRE PIGTAIL ASSY
	2	914002	5/16UNC HEX STOVER NUT
	2	470118	1/4UNC X 3/4 FLANGE HEX BOLT
	1	660101	LH FRT POST WLD
	1	472251	MTG SOCKET
	1	472249	SLOW MOVING VEHICLE SIGN
	1	472250	SPADE MTG BRKT
	16	900003	1/4UNC X 1" HEX BOLT
	18	470121	1/4UNC HEX FLANGE LOCK NUT
	3	900129	3/8UNC X 1" HEX BOLT
	3	914004	3/8UNC HEX STOVER NUT
	8	914008	1/2UNC HEX STOVER NUT
	2	900264	1/2UNC X 1 1/4 HEX BOLT
	2	900265	1/2UNC X 1 1/2 HEX BOLT
	2	900065	5/16UNC X 1" HEX BOLT
	1	361500	MAINFRAME WLD
	1	361585	BUMPER WLD
	1	660106	RH REAR SUPPORT WLD
	1	660107	LH CNTR POST WLD
	1	660114	TOP CNTR BRACE ANGLE WLD
	1	660100	RH FRT DOOR SUPP WLD
	1	660117	RH TOP DOOR SUPPORT WLD
	1	660120	LH REAR SUPPORT POST
	1	660125	ENG COMPARTMENT BRACE
	1	660112	REAR CNTR SUPPORT WLD
	1	660110	FRONT CNTR SUPPORT WLD
	1	660190	REAR DOOR LATCH ROD GUIDE 01
	14	193052	FOAM, .25 X 1.00 X 50 FT W/PSA
	5	193053	FOAM, .50 X 1.00 X 50 FT W/PSA

STS12

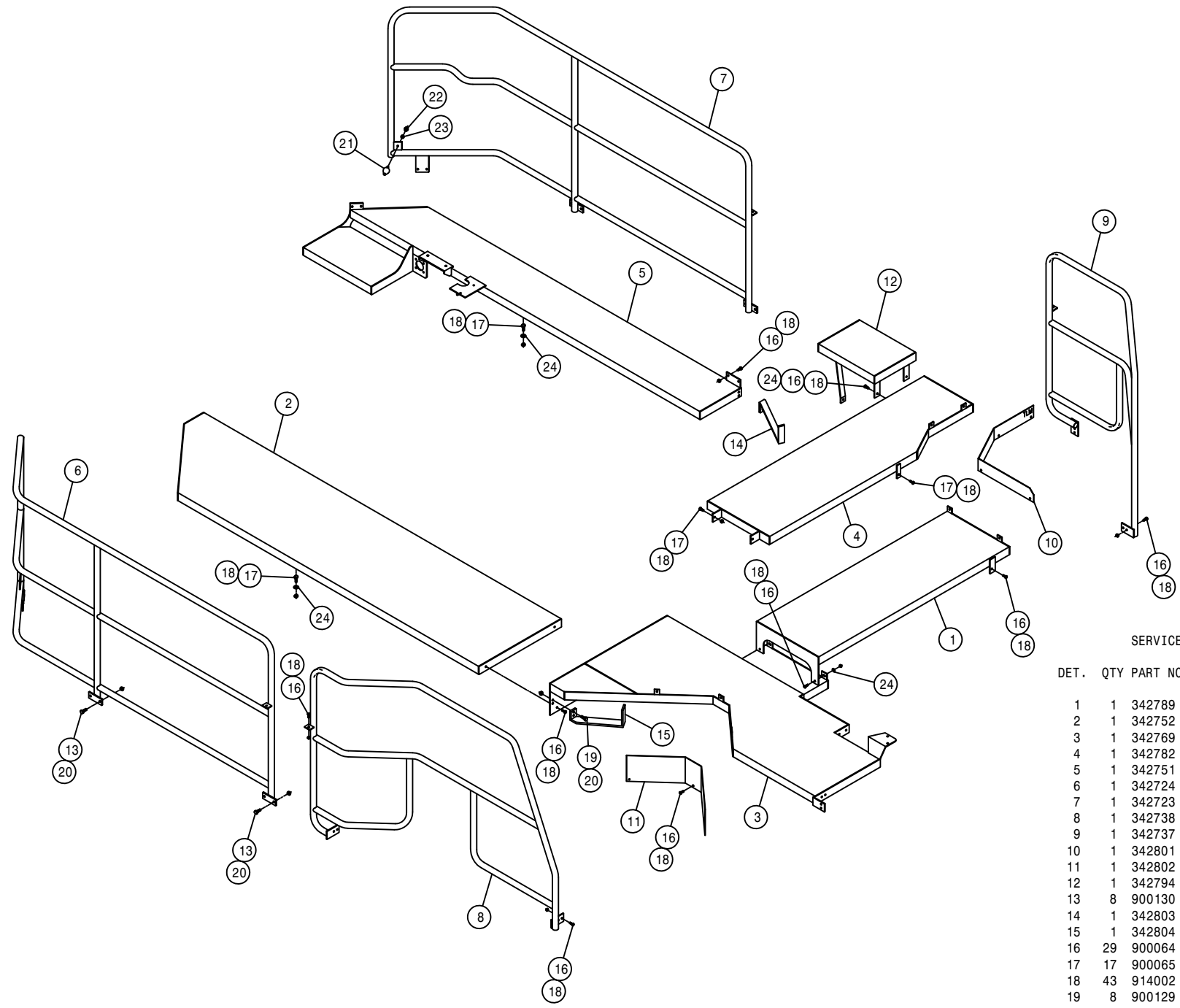

SERVICE PLATFORM ASSEMBLY

DET.	QTY	PART NO.	DESCRIPTION
	1	342789	CENTER SERV PLATFORM WLD
	2	342752	LH SERV PLATFORM WLD
	3	342769	LH REAR SERV PLATFORM WLD
	4	342782	CENTER FRT PLATFORM WLD
	5	342751	RH SERV PLATFORM WLD
	6	342724	LH FRT HANDRAIL WLD
	7	342723	RH FRT HANDRAIL WLD
	8	342738	LH REAR HANDRAIL WLD
	9	342737	RH REAR HANDRAIL WLD
	10	342801	RH SERV PLATFORM SHIELD
	11	342802	LH SERV PLATFORM SHIELD
	12	342794	RH STEP WLD
	13	8 900130	3/8UNC X 1 1/4 HEX BOLT
	14	342803	RH REAR LEG HOSE SUPPORT
	15	342804	LH REAR LEG HOSE SUPPORT
	16	29 900064	5/16UNC X 3/4 HEX BOLT
	17	17 900065	5/16UNC X 1" HEX BOLT
	18	43 914002	5/16UNC HEX STOVER NUT
	19	8 900129	3/8UNC X 1" HEX BOLT
	20	16 914004	3/8UNC HEX STOVER NUT
	21	2 470314	RUBBER BUMPER,BULLET W/3/8-24S
	22	2 910005	3/8UNF HEX NUT
	23	2 920502	3/8 LOCK WASHER
	24	16 920001	5/16 SAE FLAT WASHER

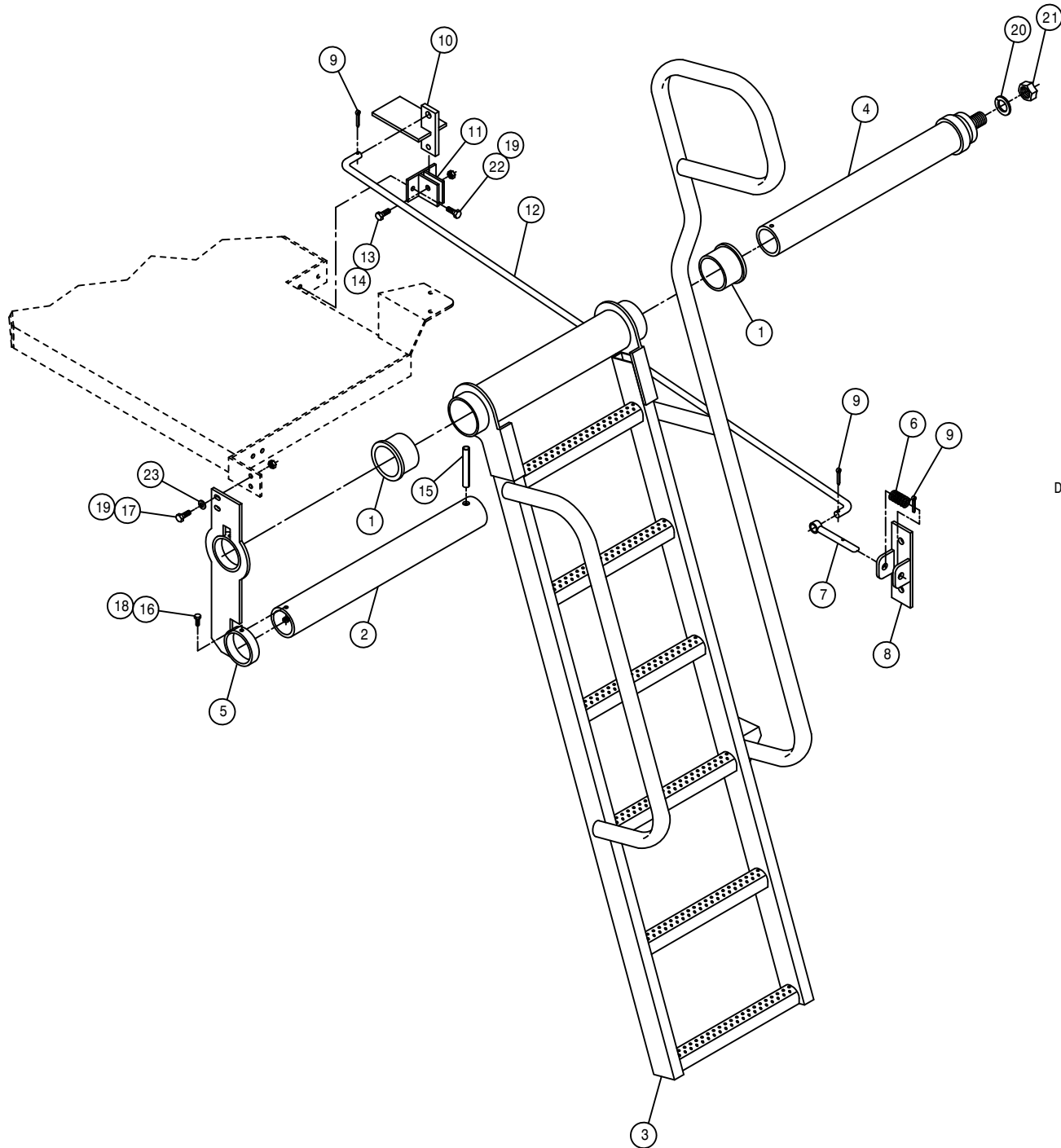

LADDER ASSEMBLY

DET.	QTY	PART NO.	DESCRIPTION
1	2	121102	LADDER PIVOT BEARING, ORKOT
2	1	342805	LADDER MT TUBE
3	1	342920	LADDER WLD, STS10
4	1	342930	LADDER PIVOT TUBE WLD, STS10
5	1	342934	LH PLTFRM SUPP BRKT WLD, STS10
6	1	482021	5/8" X 1 5/8" COMPRESS SPRING
7	1	342937	LADDER LATCH PIN WLD, STS10
8	1	342940	LADDER LATCH PIN MT WLD, STS10
9	3	470006	COTTER PIN 1/8 X 1
10	1	342944	LADDER FOOT RELEASE WLD, STS10
11	1	342947	LADDER FOOT REL MT WLD, STS10
12	1	342950	LADDER FOOT RELEASE ROD, STS10
13	1	900127	3/8UNC X 1 1/4 HEX BOLT 1"THD
14	1	914004	3/8UNC HEX STOVER NUT
15	1	473978	ROLL PIN, 1/2 X 3 1/2 LG
16	2	900003	1/4UNC X 1" HEX BOLT
17	2	900065	5/16UNC X 1" HEX BOLT
18	2	914000	1/4UNC HEX STOVER NUT
19	4	914002	5/16UNC HEX STOVER NUT
20	1	920508	1" LOCK WASHER
21	1	914016	1" UNC HEX STOVER NUT
22	2	900064	5/16UNC X 3/4 HEX BOLT
23	2	920001	5/16 SAE FLAT WASHER

1000 GALLON SS TANK ASSEMBLY

DET. QTY PART NO. DESCRIPTION

1	1	763561	LID ASSY FOR 763550 TANK
2	1	763562	10" FILL LID SEAL FOR 763550
3	1	500034	1 1/2"NPT-90 ST EL, POLY
4	1	500036	1 1/2"X 1"NPT REDU BUSH, POLY
5	1	500063	1"NPT PIPE PLUG, POLY
6	1	500074	1"NPT-1" HOSE BARB, POLY
7	1	763563	16" MANHOLE SEAL FOR 763550
8	1	500104	1/4NPT-90-1/4 HOSE BARB, POLY
9	3	500194	2"FP FLANGE CLAMP, S.S.
10	3	500195	2"FP FLANGE GASKET EPDM
11	7	500208	3" FLANGE CLAMP, S.S.
12	7	500209	3" FLANGE GASKET EPDM
13	1	505225	1"-1/4"NPT REDU BUSH, POLY
14	1	507103	PIPE CAP, 2.00FNPT S.S.
15	1	507725	REDU BUSH 2 X 1 1/2 S.S.
16	1	507726	PIPE ELBOW, 1"NPT 90D S.S.
17	1	507727	STREET ELBOW, 1 1/2" 90D S.S.
18	1	520067	HOSE CLAMP NO 28 STAINLESS
19	1	520069	HOSE CLAMP NO 6 STAINLESS
20	4	520090	HOSE CLAMP NO 16 STAINLESS
21	1	601471	HOSE, 1" X 60 CLEAR VINYL
22	1	716100	1" HOSE BARB X 1"MNPT S.S.
23	1	716106	1 1/2"HOSE BARB-1 1/2MNPT S.S.
24	1	763570	1000 GAL SS TANK
25	1	500196	2"FP FLANGE-2" HOSE BARB POLY
26	1	500219	2"FP FLANGE-90-2"FP FLANGE LBO
27	1	696148	BALL VLV, 2"FP FLANGE
28	2	500213	3"FLANGE-90-3"FLANGE LBO POLY
29	3	500210	3" FLANGE-3" HOSE BARB POLY
30	1	696149	BALL VLV, 3" FLANGE
31	1	500217	3" FLANGE TEE POLY
32	1	500211	3" FLANGE-90-3" HOSE BARB POLY
33	6	520145	356 T-BOLT HOSE CLAMP SS
34	1	520141	2.31/2.62 T-BOLT HOSE CLAMP SS
35	2	470321	BALER BELT, 4.00 X 67.00 2-PLY
36	4	482016	SPRING, 1.40 X 3.00 COMPRSN
37	8	920006	3/4 SAE FLAT WASHER
38	4	900416	3/4UNC X 6 1/2 HEX BOLT
39	4	914012	3/4UNC HEX STOVER NUT
40	1	690731	SOLU TUBE, 3.00 S.S. SIDE FILL
41	1	601503	HOSE, 3 X 8 POLY HELIX EPDM
42	1	601504	HOSE, 3 X 22 POLY HELIX EPDM
43	1	601505	HOSE, 3 X 40 POLY HELIX EPDM
44	1	601506	HOSE, 3 X 74 POLY HELIX EPDM
45	1	601520	HOSE, 2 X 64 2F-1W EPDM
46	1	601508	HOSE, 3 X 64 POLY HELIX EPDM
47	1	601490	HOSE, 1/4 X 95 1 BR BLK EPDM
48	1	601500	HOSE, 1 1/2 X 43 2BR BLK EPDM
49	1	601496	HOSE, 1 X 120 1BR BLK EPDM
50	1	601494	HOSE, 1 X 108 1BR BLK EPDM
51	2	914002	5/16UNC HEX STOVER NUT
52	2	900064	5/16UNC X 3/4 HEX BOLT

NOTE: ITEMS (*) ARE USED WITH THE SIDE FILL OPTION

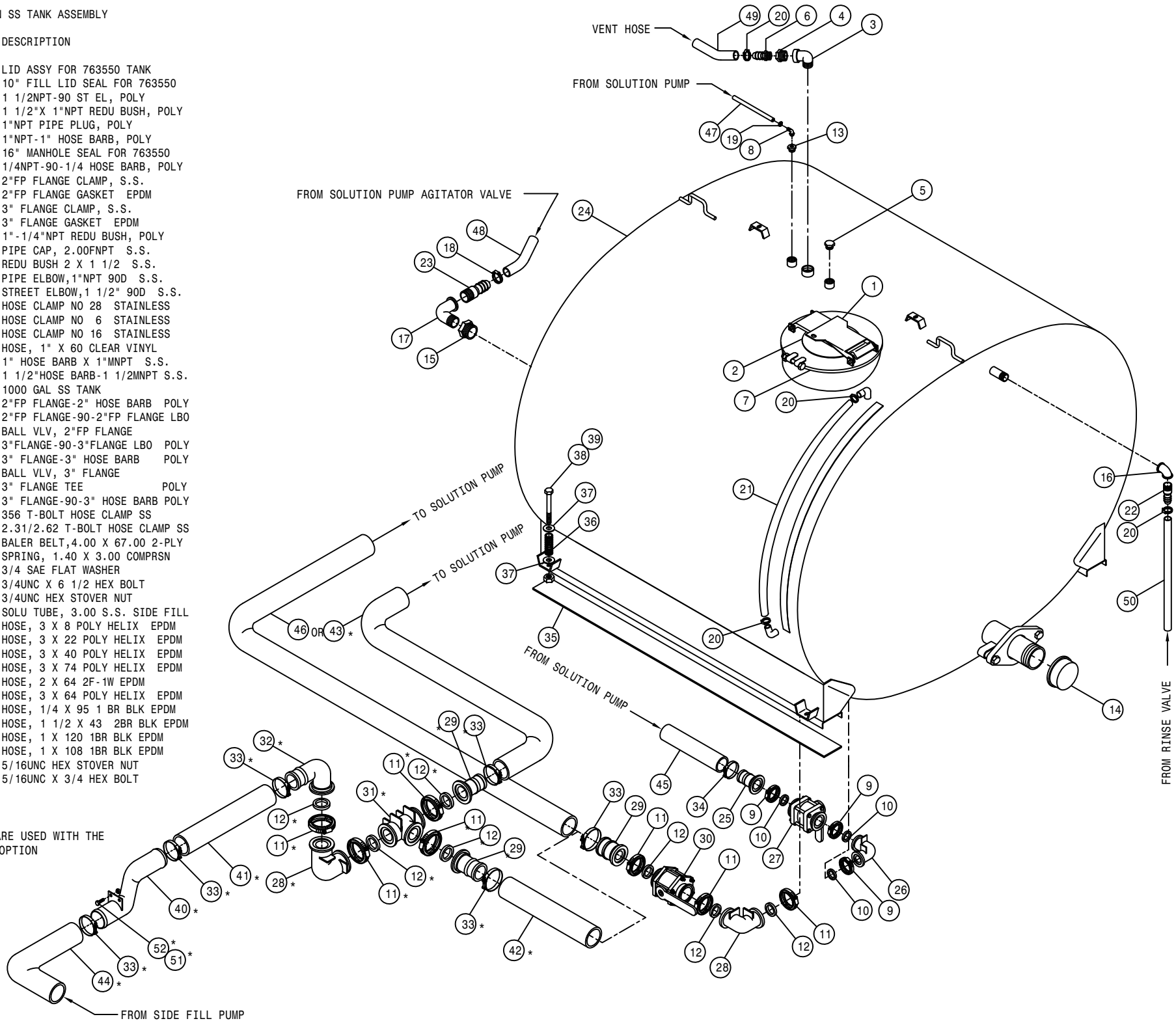

52

250052

POLY RINSE TANK ASSEMBLY

DET.	QTY	PART NO.	DESCRIPTION
1	3	500024	1"NPT-90-1"HOSE BARB, POLY
2	2	500063	1"NPT PIPE PLUG, POLY
3	1	763553	100 GAL POLY TANK
4	1	763590	POLY RINSE TANK MT WLD STS12
5	1	763594	POLY RINSE TANK MT PAD STS12
6	2	763595	POLY RINSE TNK STRAP ASSY STS
7	2	900392	1/2UNC X 1 1/2 SOCKET CAP SCR
8	4	914008	1/2UNC HEX STOVER NUT
9	2	920004	1/2 SAE FLAT WASHER
10	2	500157	1" FLANGE GASKET EPDM
11	2	500159	1" FLANGE CLAMP, S.S.
12	1	500163	1" FLANGE-1" MNPT ADPTR POLY
13	1	500173	1" FLANGE-90-1" HOSE BARB POLY
14	1	505198	SS PIPE NIPPLE 1.00NPT-3.00
15	1	690660	LINE "T" STRAINER, 1" FLANGE
16	1	690669	100 MESH SCREEN FOR 690660
17	1	696004	BALL VLV,1.00NP 3WAY-SIDE POLY
18	3	520090	HOSE CLAMP NO 16 STAINLESS
19	1	601179	HOSE, 1 X 26 1BR BLK EPDM
20	1	601535	HOSE, 1 X 46 1BR BLK EPDM

NOTE: RINSE TANK FOR SS SOLUTION TANK OPTION IS SHOWN. FOR POLY SOLUTION TANK OPTION USE DETAILS 1,2, AND 3.

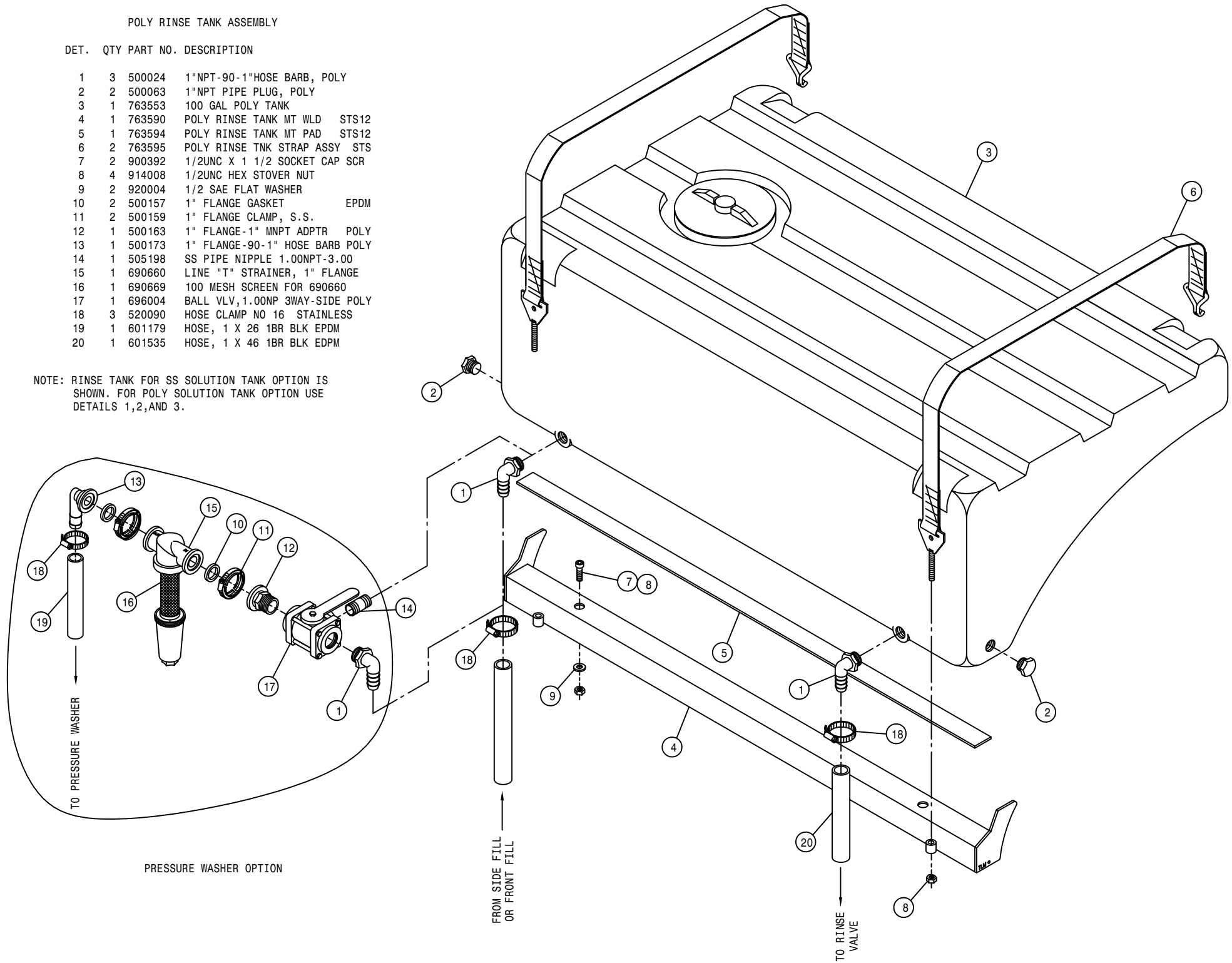

PRESSURE WASHER OPTION

1000 GALLON POLY TANK ASSEMBLY

DET. QTY PART NO. DESCRIPTION

1	1	472349	1/4 X 3/4 20THD-IN TEK TYPE
2	3	500194	2"FP FLANGE CLAMP, S.S.
3	3	500195	2"FP FLANGE GASKET EPDM
4	7	500208	3" FLANGE CLAMP, S.S.
5	7	500209	3" FLANGE GASKET EPDM
6	1	500196	2"FP FLANGE-2" HOSE BARB POLY
7	1	500219	2"FP FLANGE-90-2"FP FLANGE LBO
8	1	696148	BALL VLV, 2"FP FLANGE
9	3	500210	3" FLANGE-3" HOSE BARB POLY
10	2	500213	3"FLANGE-90-3"FLANGE LBO POLY
11	1	696149	BALL VLV, 3" FLANGE
12	8	473847	10-12 X 1 PHIL FLAT HD SCR SS
13	5	500026	3/4NPT-90-1"HOSE BARB, POLY
14	1	500043	3/4NPT PIPE PLUG, POLY
15	1	500104	1/4NPT-90-1/4 HOSE BARB, POLY
16	6	500110	3/4NPT BLKHD TANK FITTING POLY
17	1	500112	2"NPT BLKHD TANK FITTING POLY
18	2	500113	2"NPT BLKHD FITTING GASKET
19	1	500114	3"NPT BLKHD TANK FITTING POLY
20	2	500115	3"NPT BLKHD FITTING GASKET
21	10	500158	1 1/2" GASKET FOR 2" FLANGE
22	1	500164	3" FLANGE-3" MNPT ADPTR POLY
23	1	500204	2"FP FLANGE-2"MNPT POLY
24	1	737873	ROTARY NOZZLE, TEFLON
25	2	737879	EDUCTOR NOZZLE, 3/4MNPT TEEJET
26	1	763431	8" STRAINER BASKET, SOLU TANK
27	1	763571	1000 GAL POLY TANK
28	1	763601	POLY TANK CRADLE WELDMT STS10
29	4	763612	1.625 X 2.375 X 16GA WASHER
30	1	763613	3.250 X 4.250 X 16GA WASHER
31	1	763614	4.500 X 5.500 X 16GA WASHER
32	1	763624	10" TANK LID W/RING ASSY, POLY
33	1	763625	10" TANK LID, POLY
34	1	763626	10" TANK LID RING, POLY
35	2	763630	POLY TANK STRAP ASSY STS10
36	6	900538	1/2UNC X 3 1/2 HEX BOLT FULL
37	6	914008	1/2UNC HEX STOVER NUT
38	1	763621	SOLU HOSE SUPP,POLY TANK STS10
39	2	470321	BALER BELT,4.00 X 67.00 2-PLY
40	4	482016	SPRING, 1.40 X 3.00 COMPRSN
41	4	900416	3/4UNC X 6 1/2 HEX BOLT
42	4	914012	3/4UNC HEX STOVER NUT
43	8	920006	3/4 SAE FLAT WASHER
44	1	500217	3" FLANGE TEE POLY
45	1	500211	3" FLANGE-90-3" HOSE BARB POLY
46	6	520145	356 T-BOLT HOSE CLAMP SS
47	1	690731	SOLU TUBE, 3.00 S.S. SIDE FILL
48	1	520141	2.31/2.62 T-BOLT HOSE CLAMP SS
49	1	601503	HOSE, 3 X 8 POLY HELIX EPDM
50	1	601504	HOSE, 3 X 22 POLY HELIX EPDM
51	1	601505	HOSE, 3 X 40 POLY HELIX EPDM
52	1	601506	HOSE, 3 X 74 POLY HELIX EPDM
53	1	601520	HOSE, 2 X 64 2F-1W EPDM
54	1	601508	HOSE, 3 X 64 POLY HELIX EPDM
55	2	914002	5/16UNC HEX STOVER NUT
56	2	900064	5/16UNC X 3/4 HEX BOLT
57	1	504850	CPVC PIPE NIPPLE .75NPT-24.00

NOTE: ITEMS (*) ARE USED WITH THE SIDE FILL OPTION.

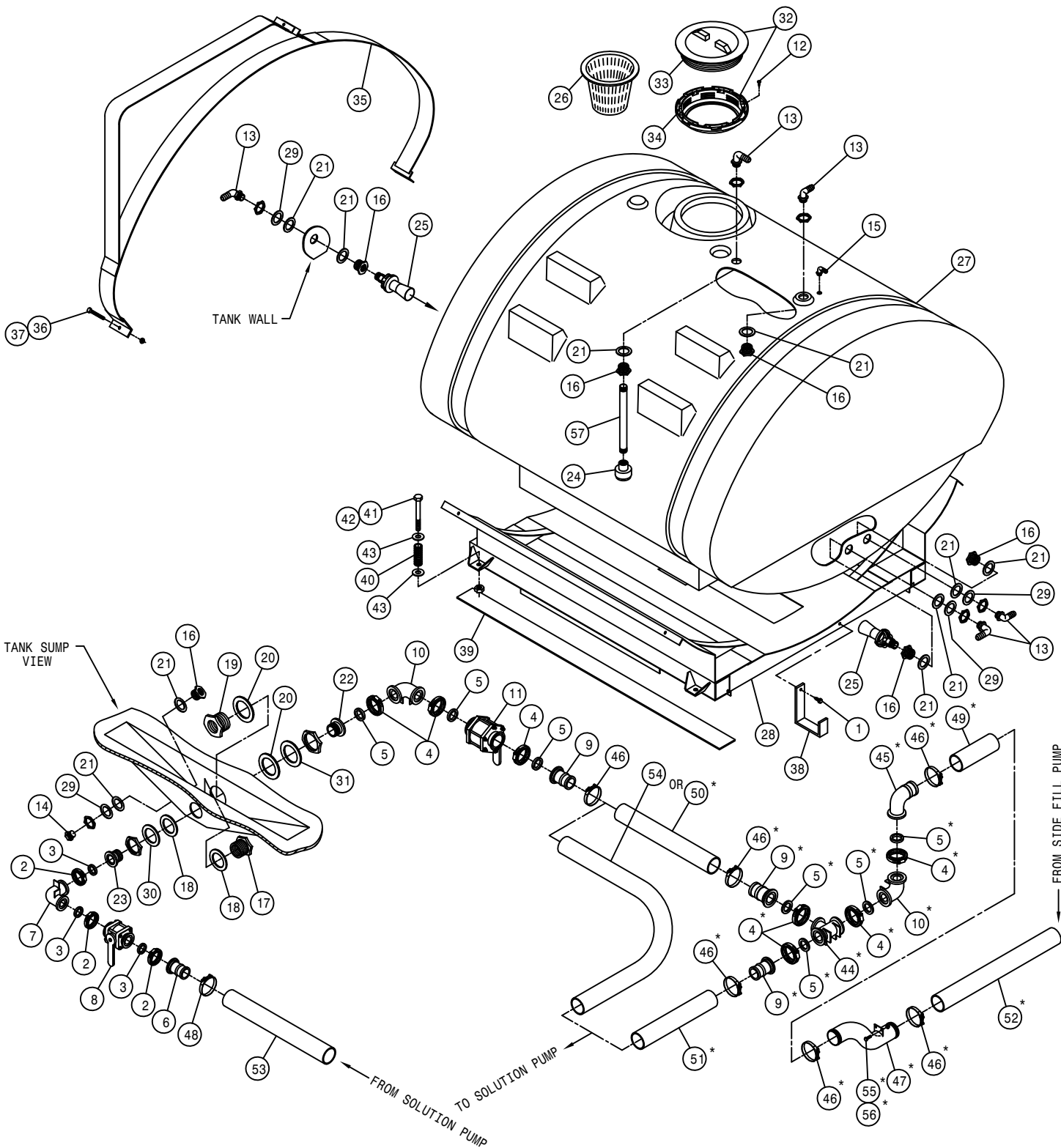

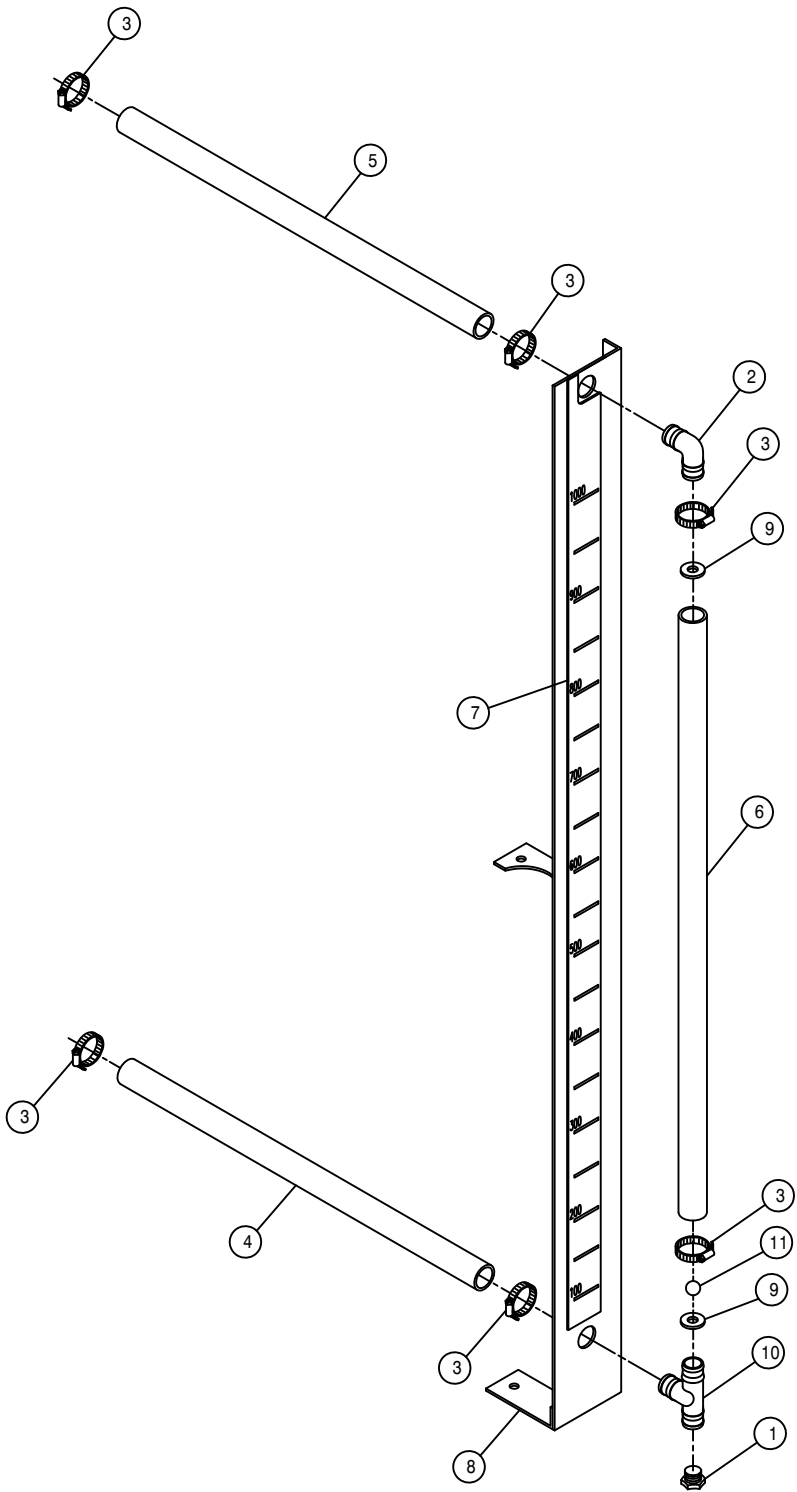

SIGHT GAGE ASSEMBLY

DET.	QTY	PART NO.	DESCRIPTION
1	1	500062	1/2"NPT PIPE PLUG, POLY
2	1	500109	1.00-90-1.00 HOSE BARB, POLY
3	6	520090	HOSE CLAMP NO 16 STAINLESS
4	1	601558	HOSE, 1" X 24 CLEAR VINYL
5	1	601559	HOSE, 1" X 36 CLEAR VINYL
6	1	601560	HOSE, 1" X 49 CLEAR VINYL
7	1	650123	DECAL, SIGHT GAGE, POLY STS10
8	1	763616	SIGHT GAGE WELD, POLY TNK STS10
9	2	763620	SS SIGHT GAGE WASHER STS10
10	1	763622	SIGHT GAGE TEE, POLY TNK STS10
11	1	763623	GREEN POLYPROPYLENE BALL .750"

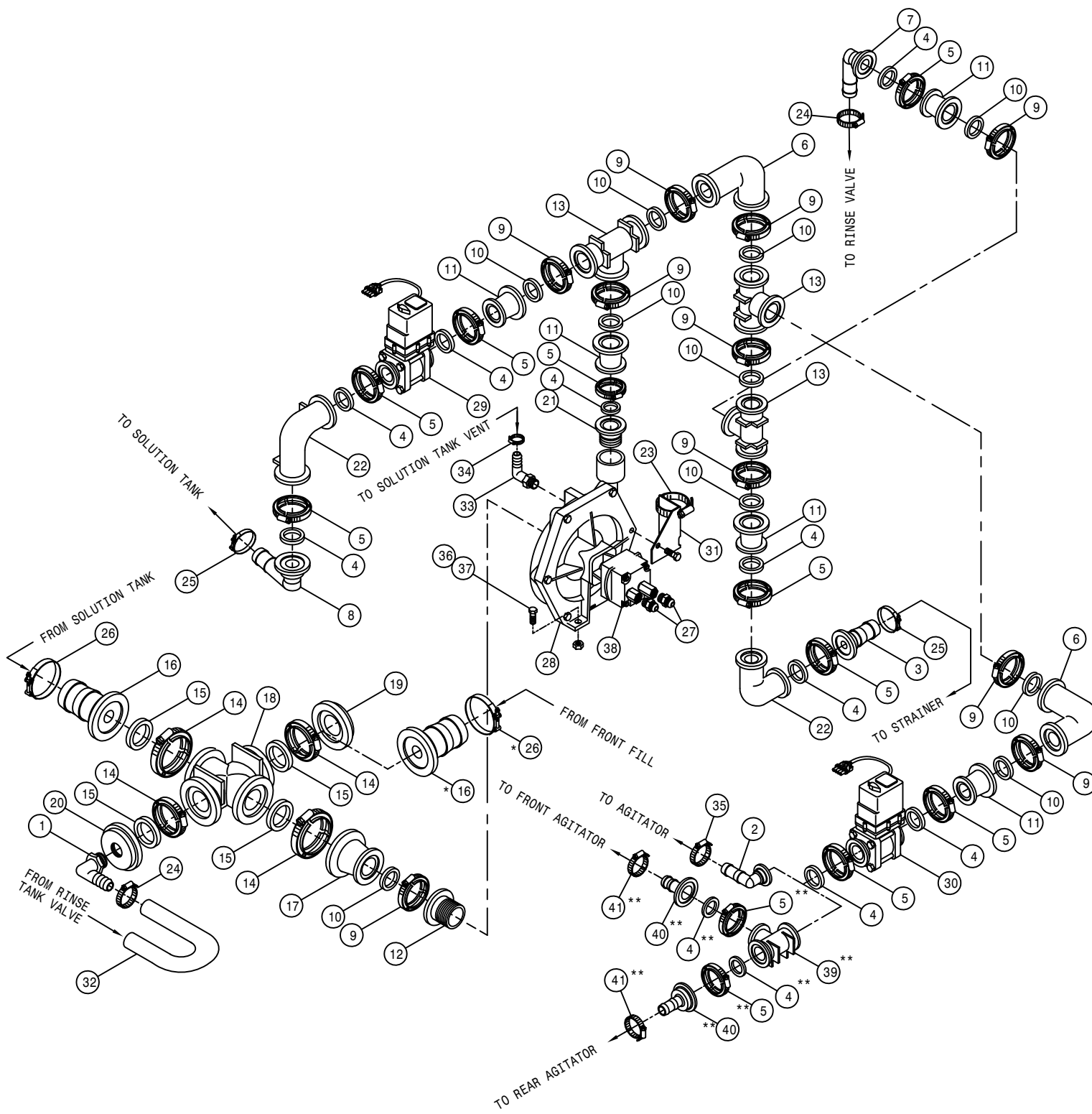

SOLUTION PUMP ASSEMBLY

DET.	QTY	PART NO.	DESCRIPTION
1	1	500024	1"NPT-90-1"HOSE BARB, POLY
2	1	500153	2" FLANGE-90-1 1/2 HBARB POLY
3	1	500154	2" FLANGE-2" HOSE BARB POLY
4	11	500158	1 1/2" GASKET FOR 2" FLANGE
5	11	500160	2" FLANGE CLAMP, S.S.
6	2	500180	2"FLANGE-90-2"FLANGE LBO POLY
7	1	500189	2" FLANGE-90-1" HOSE BARB POLY
8	1	500191	2" FLANGE-90-2" HOSE BARB POLY
9	10	500194	2"FP FLANGE CLAMP, S.S.
10	10	500195	2"FP FLANGE GASKET EPDM
11	5	500199	2"FP FLANGE-2"FLANGE REDU POLY
12	1	500205	2"FP FLANGE-2"MNPT ADPTR S.S.
13	3	500207	2"FP FLANGE TEE POLY
14	4	500208	3" FLANGE CLAMP, S.S.
15	4	500209	3" FLANGE GASKET EPDM
16	2	500210	3" FLANGE-3" HOSE BARB POLY
17	1	500212	3"FLANGE-2"FP FLANGE REDU POLY
18	1	500214	3"FP FLANGE CROSS
19	1	500215	3" FLANGE CAP PLUG POLY
20	1	500216	3"FLANGE PLUG W/1"FNPT POLY
21	1	500218	2"FLANGE-1 1/2"MNPT ADPTR S.S.
22	2	500219	2"FP FLANGE-90-2"FP FLANGE LBO
23	2	520052	HOSE CLAMP NO 52 STAINLESS
24	2	520090	HOSE CLAMP NO 16 STAINLESS
25	2	520141	T.31/2.62 T-BOLT HOSE CLAMP SS
26	2	520145	356 T-BOLT HOSE CLAMP SS
27	2	618273	1 1/16MJIC-1/2MNPT ADPTR
28	1	690670	HYPRO PUMP, 9305C-HM3CB
29	1	696176	ELECT BALL VLV,2"FLANGE BANJO
30	1	696179	ELECT BALL VLV,2"FLANGE 4-SSEC
31	1	690682	SOLU PUMP TEE FTG SUPP BRKT
32	1	311511	1.00 'U' HOSE, DAYCO 70564
33	1	500103	1/8NPT-90-1/4 HOSE BARB,NYLON
34	1	520069	HOSE CLAMP NO 6 STAINLESS
35	1	520067	HOSE CLAMP NO 28 STAINLESS
36	2	914004	3/8UNC HEX STOVER NUT
37	2	900131	3/8UNC X 1 1/2 HEX BOLT
38	1	690675	HYD MOTOR, SOLU PUMP 690670
39	1	500151	2" FLANGE TEE POLY
40	2	500172	2" FLANGE-1" HOSE BARB POLY
41	2	520090	HOSE CLAMP NO 16 STAINLESS

NOTE: 1. ITEMS 16 & 26, MARKED WITH (*), ARE USED WITH THE FRONT FILL OPTION.
 2. ITEMS MARKED WITH (**) ARE USED WITH THE POLY SOLUTION TANK OPTION.

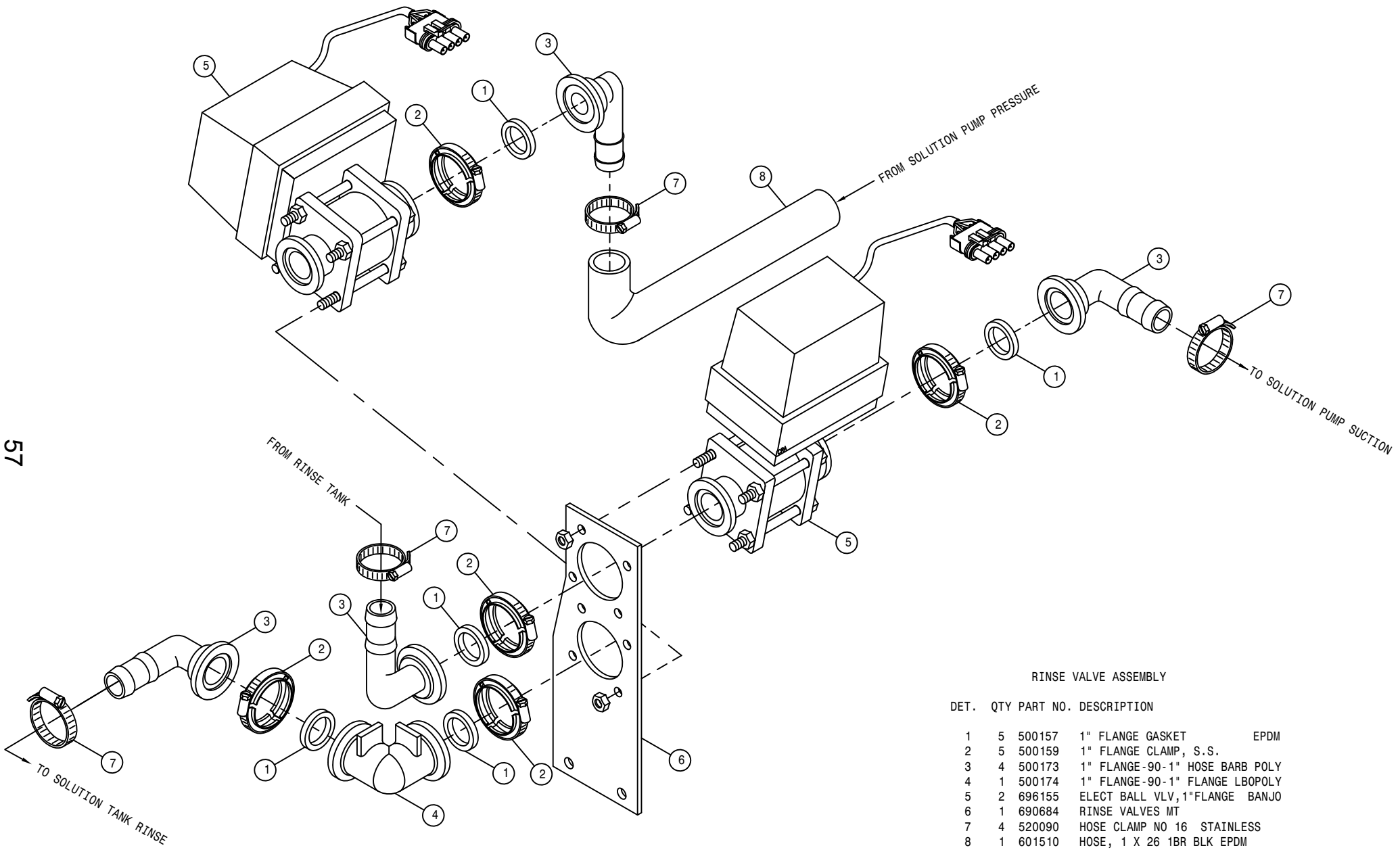

RINSE VALVE ASSEMBLY

DET.	QTY	PART NO.	DESCRIPTION	
1	5	500157	1" FLANGE GASKET	EPDM
2	5	500159	1" FLANGE CLAMP, S.S.	
3	4	500173	1" FLANGE-90-1" HOSE BARB POLY	
4	1	500174	1" FLANGE-90-1" FLANGE LBOPOLY	
5	2	696155	ELECT BALL VLV, 1" FLANGE BANJO	
6	1	690684	RINSE VALVES MT	
7	4	520090	HOSE CLAMP NO 16 STAINLESS	
8	1	601510	HOSE, 1 X 26 1BR BLK EPDM	

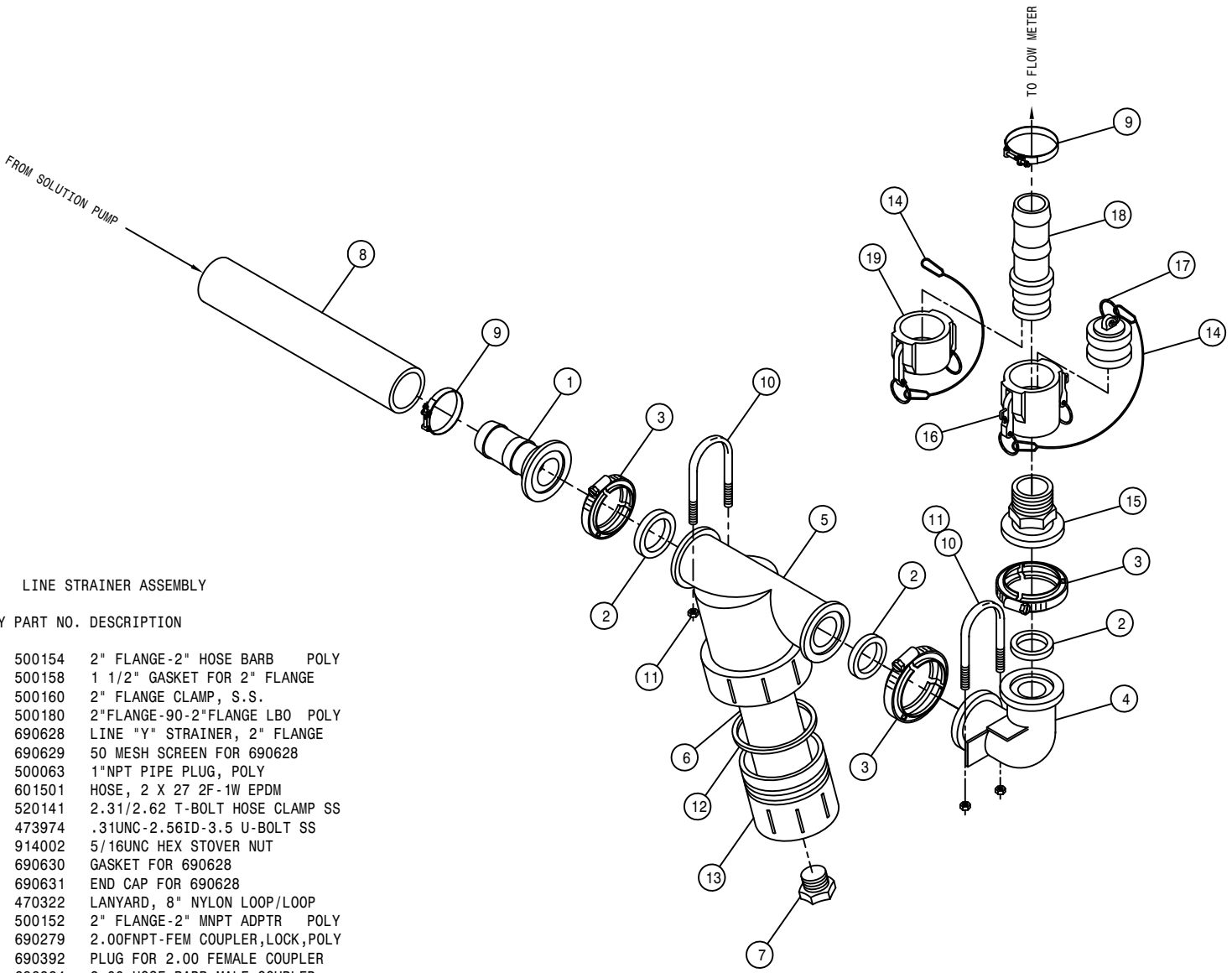

LINE STRAINER ASSEMBLY

DET.	QTY	PART NO.	DESCRIPTION
1	1	500154	2" FLANGE-2" HOSE BARB POLY
2	3	500158	1 1/2" GASKET FOR 2" FLANGE
3	3	500160	2" FLANGE CLAMP, S.S.
4	1	500180	2"FLANGE-90-2"FLANGE LBO POLY
5	1	690628	LINE "Y" STRAINER, 2" FLANGE
6	1	690629	50 MESH SCREEN FOR 690628
7	1	500063	1"NPT PIPE PLUG, POLY
8	1	601501	HOSE, 2 X 27 2F-1W EPDM
9	2	520141	2.31/2.62 T-BOLT HOSE CLAMP SS
10	2	473974	.31UNC-2.56ID-3.5 U-BOLT SS
11	4	914002	5/16UNC HEX STOVER NUT
12	1	690630	GASKET FOR 690628
13	1	690631	END CAP FOR 690628
14	2	470322	LANYARD, 8" NYLON LOOP/LOOP
15	1	500152	2" FLANGE-2" MNPT ADPTR POLY
16	1	690279	2.00FNPT-FEM COUPLER,LOCK,POLY
17	1	690392	PLUG FOR 2.00 FEMALE COUPLER
18	1	696224	2.00 HOSE BARB-MALE COUPLER
19	1	690623	CAP FOR 2.00 MALE COUPLER POLY

SOLUTION CONTROL VALVE ASSEMBLY (STANDARD)

DET. QTY PART NO. DESCRIPTION

DET.	QTY	PART NO.	DESCRIPTION
1	1	160010	SOLU PRESS GA MT WLD 280 89
2	2	470118	1/4UNC X 3/4 FLANGE HEX BOLT
3	2	470121	1/4UNC HEX FLANGE LOCK NUT
4	2	472195	5/16UNC-2 11/16ID-3 9/16U-BOLT
5	2	472349	1/4 X 3/4 20THD-IN TEK TYPE
6	2	500058	2"NPT X 2" H BARB, POLY
7	3	500189	2" FLANGE-90-1" HOSE BARB POLY
8	1	500154	2" FLANGE-2" HOSE BARB POLY
9	8	500158	1 1/2" GASKET FOR 2" FLANGE
10	8	500160	2" FLANGE CLAMP, S.S.
11	2	500172	2" FLANGE-1" HOSE BARB POLY
12	1	500176	2" FLANGE CROSS POLY
13	1	500181	2" FLANGE PLUG W/1/4"FNPT POLY
14	2	520056	HOSE CLAMP NO 56 STAINLESS
15	5	520090	HOSE CLAMP NO 16 STAINLESS
16	2	520070	HOSE CLAMP NO 8 STAINLESS
17	3	520141	2.31/2.62 T-BOLT HOSE CLAMP SS
18	2	601502	HOSE, 2 X 56 2F-1W EPDM
19	1	601514	HOSE, 1/2 X 66 1BR BLK EPDM
20	4	914002	5/16UNC HEX STOVER NUT
21	2	618556	1/4NPT-90-1/2 HOSE BARB,POLY
22	1	690359	PRESSURE GA GLYCERI 100 PSI
23	1	690529	RFM 100 FLOW METER, RAVEN
24	1	696180	ELECT 3-BALL VLV,2" FLG BANJO
25	3	696176	ELECT BALL VLV,2"FLANGE BANJO

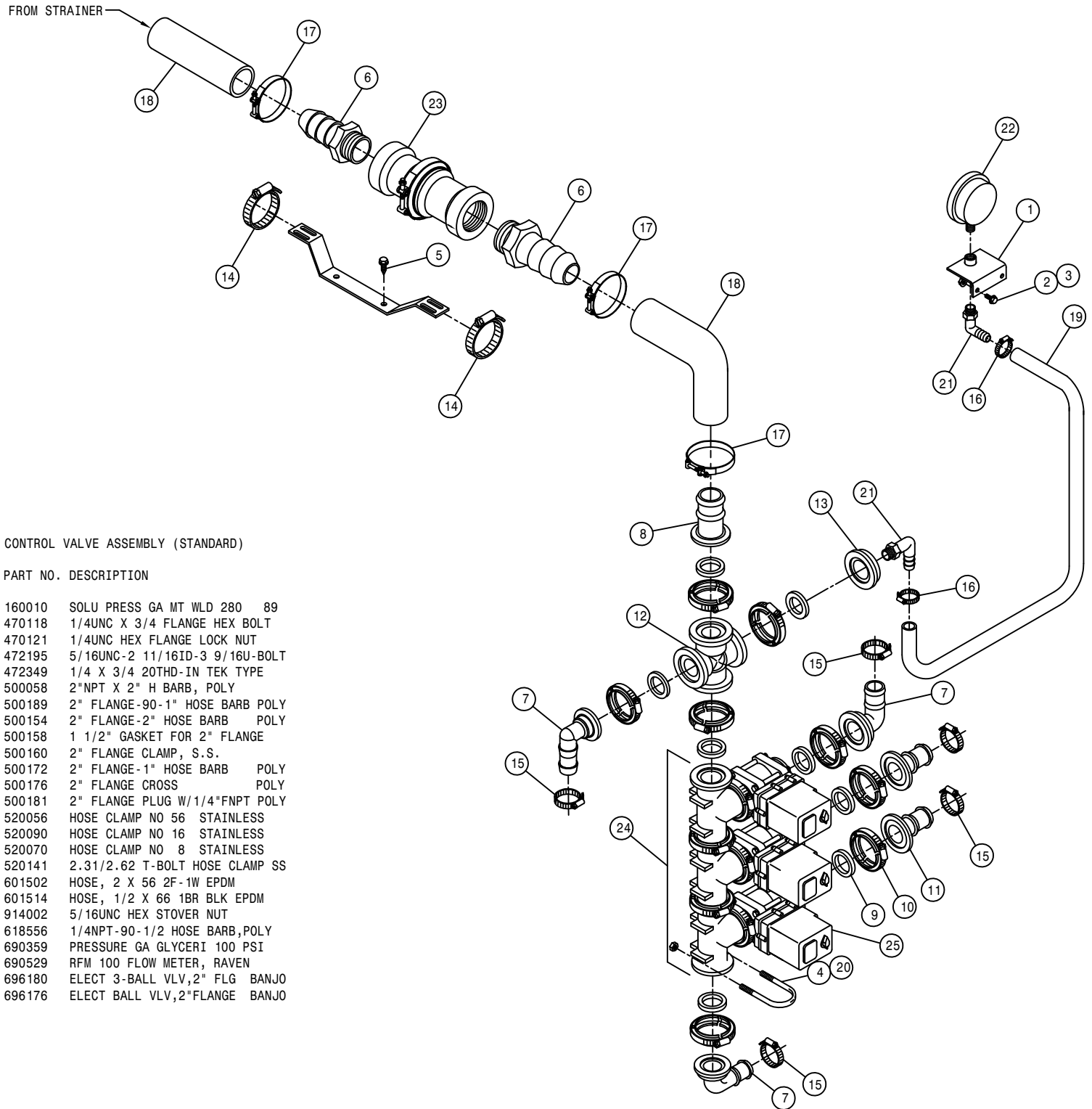

80'-90' SOLUTION VALVE ASSEMBLY (STANDARD)

DET. QTY PART NO. DESCRIPTION

1	2	500158	1 1/2" GASKET FOR 2" FLANGE
2	2	500160	2" FLANGE CLAMP, S.S.
3	2	500172	2" FLANGE - 1" HOSE BARB POLY
4	1	690745	2" SOLU VLV MT WLD
5	1	696176	ELECT BALL VLV, 2" FLANGE BANJO
6	1	520067	HOSE CLAMP NO 28 STAINLESS
7	2	520090	HOSE CLAMP NO 16 STAINLESS

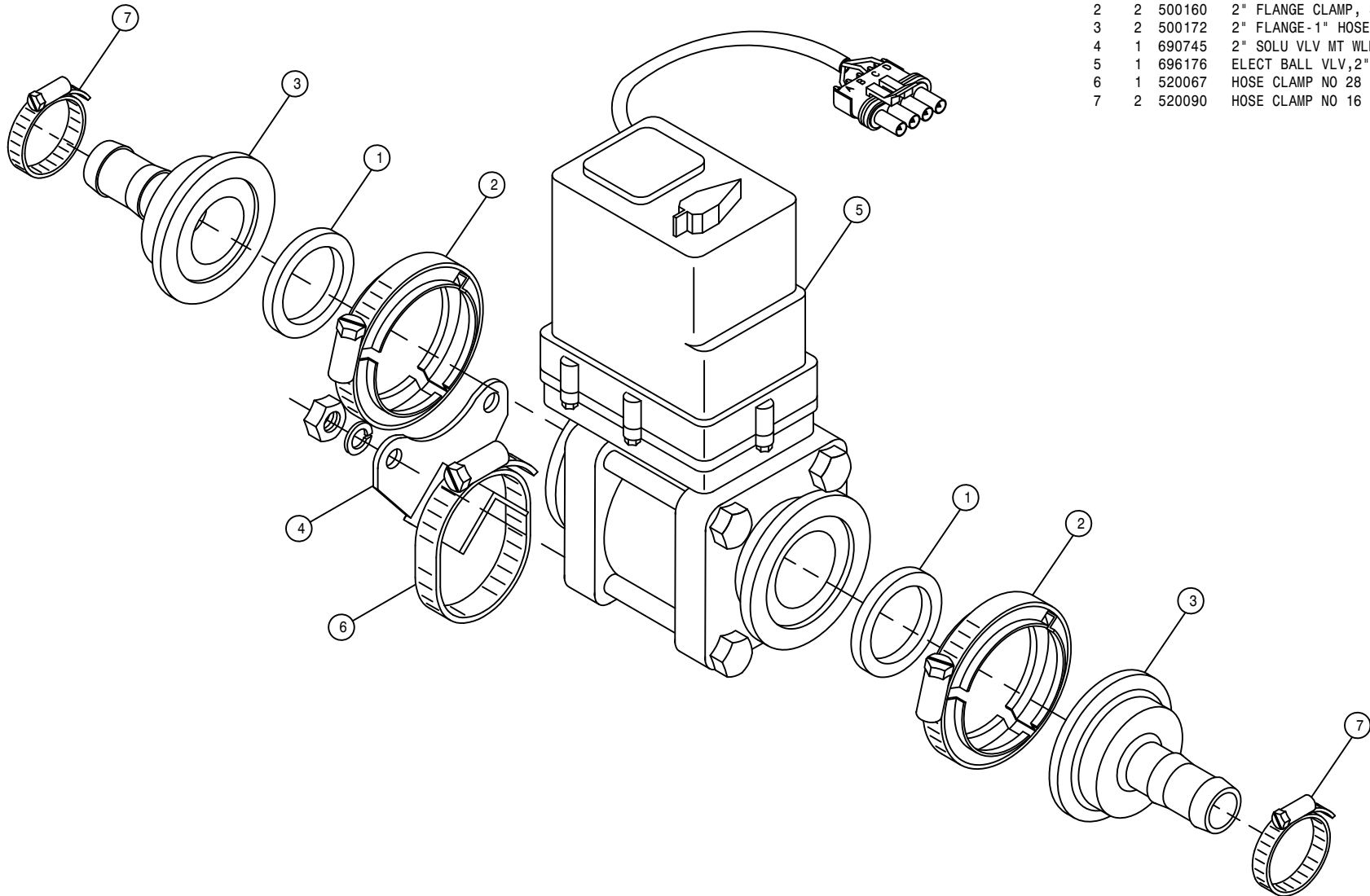

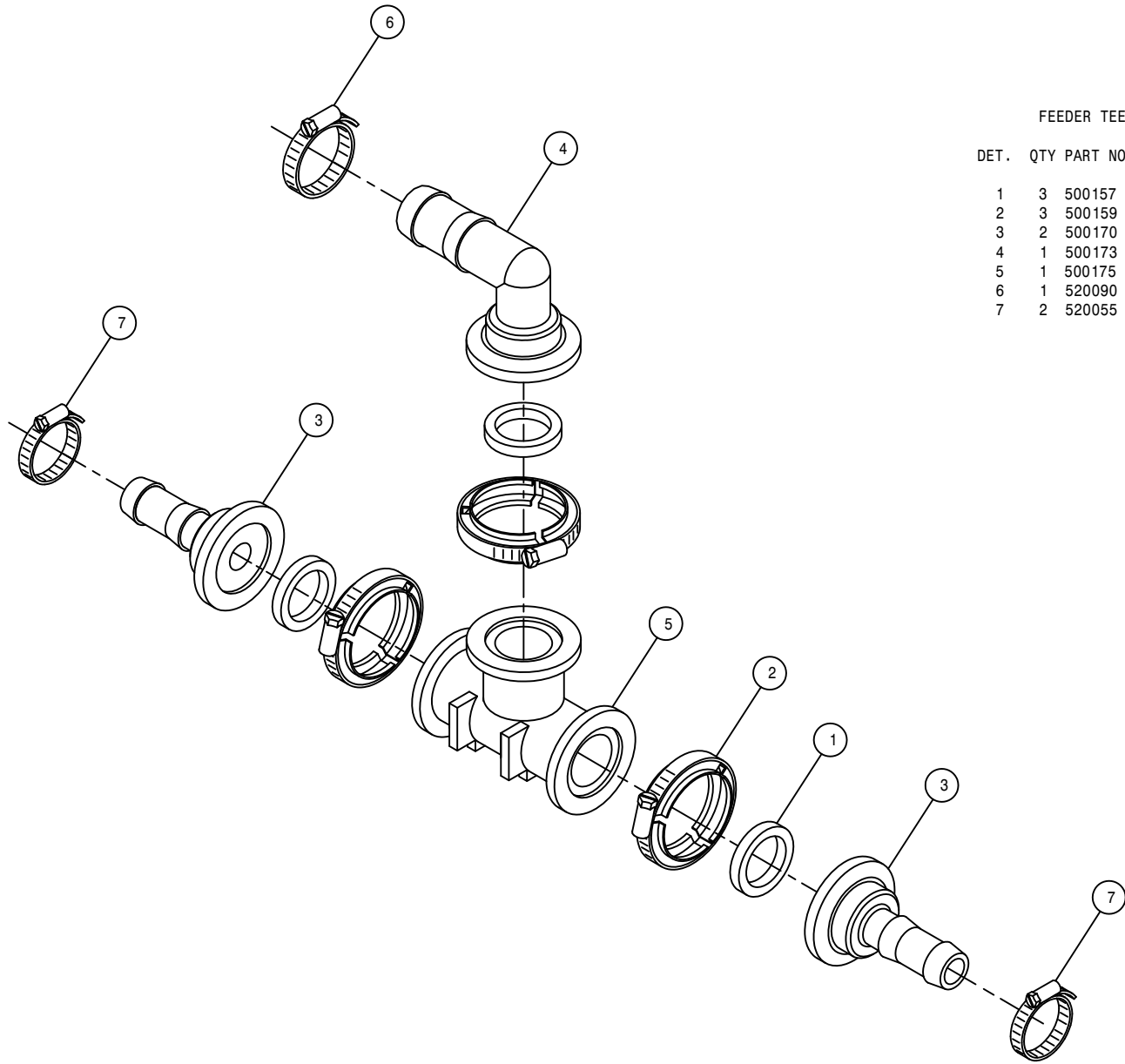

FEEDER TEE ASSEMBLY (STANDARD)

DET. QTY PART NO. DESCRIPTION

1	3	500157	1" FLANGE GASKET	EPDM
2	3	500159	1" FLANGE CLAMP, S.S.	
3	2	500170	1" FLANGE-3/4" HOSE BARB	POLY
4	1	500173	1" FLANGE-90-1" HOSE BARB	POLY
5	1	500175	1" FLANGE TEE	POLY
6	1	520090	HOSE CLAMP NO 16	STAINLESS
7	2	520055	HOSE CLAMP NO 12	STAINLESS

80'-90' FEEDER TEE ASSEMBLY (STANDARD)

DET. QTY PART NO. DESCRIPTION

DET.	QTY	PART NO.	DESCRIPTION	
1	5	500157	1" FLANGE GASKET	EPDM
2	5	500159	1" FLANGE CLAMP, S.S.	
3	1	500171	1" FLANGE-1" HOSE BARB	POLY
4	3	500170	1" FLANGE-3/4" HOSE BARB	POLY
5	2	500175	1" FLANGE TEE	POLY
6	3	520055	HOSE CLAMP NO 12	STAINLESS
7	1	520090	HOSE CLAMP NO 16	STAINLESS

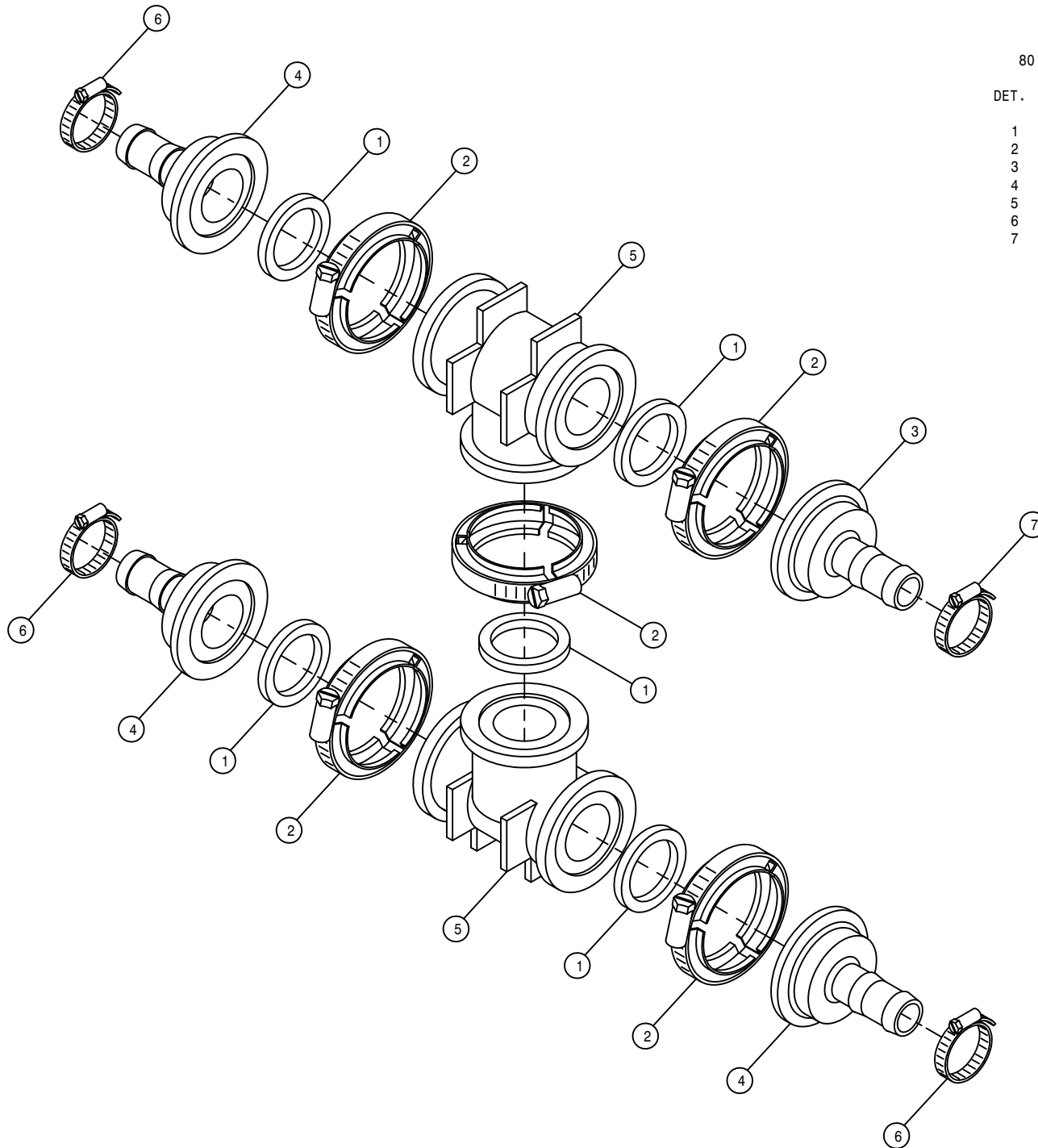

90° BALL VALVE ASSEMBLY (STANDARD)

DET. QTY PART NO. DESCRIPTION

1	2	500157	1" FLANGE GASKET	EPDM
2	2	500159	1" FLANGE CLAMP, S.S.	
3	2	500170	1" FLANGE-3/4" HOSE BARB	POLY
4	1	701191	1" SOLU VLV MT WLD	
5	1	696147	BALL VLV, 1" FLANGE	
6	1	520085	HOSE CLAMP NO 24	STAINLESS
7	2	520055	HOSE CLAMP NO 12	STAINLESS

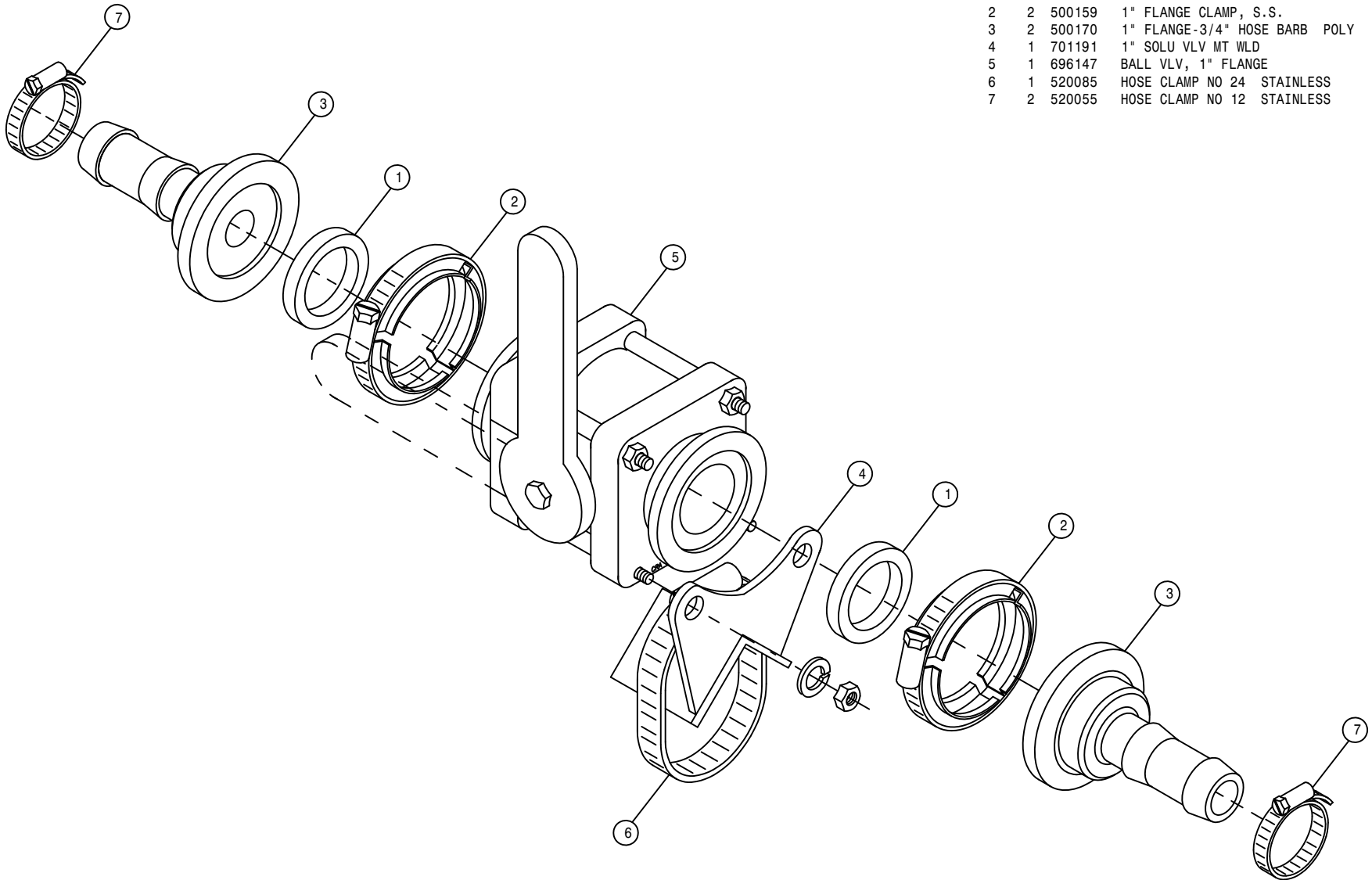

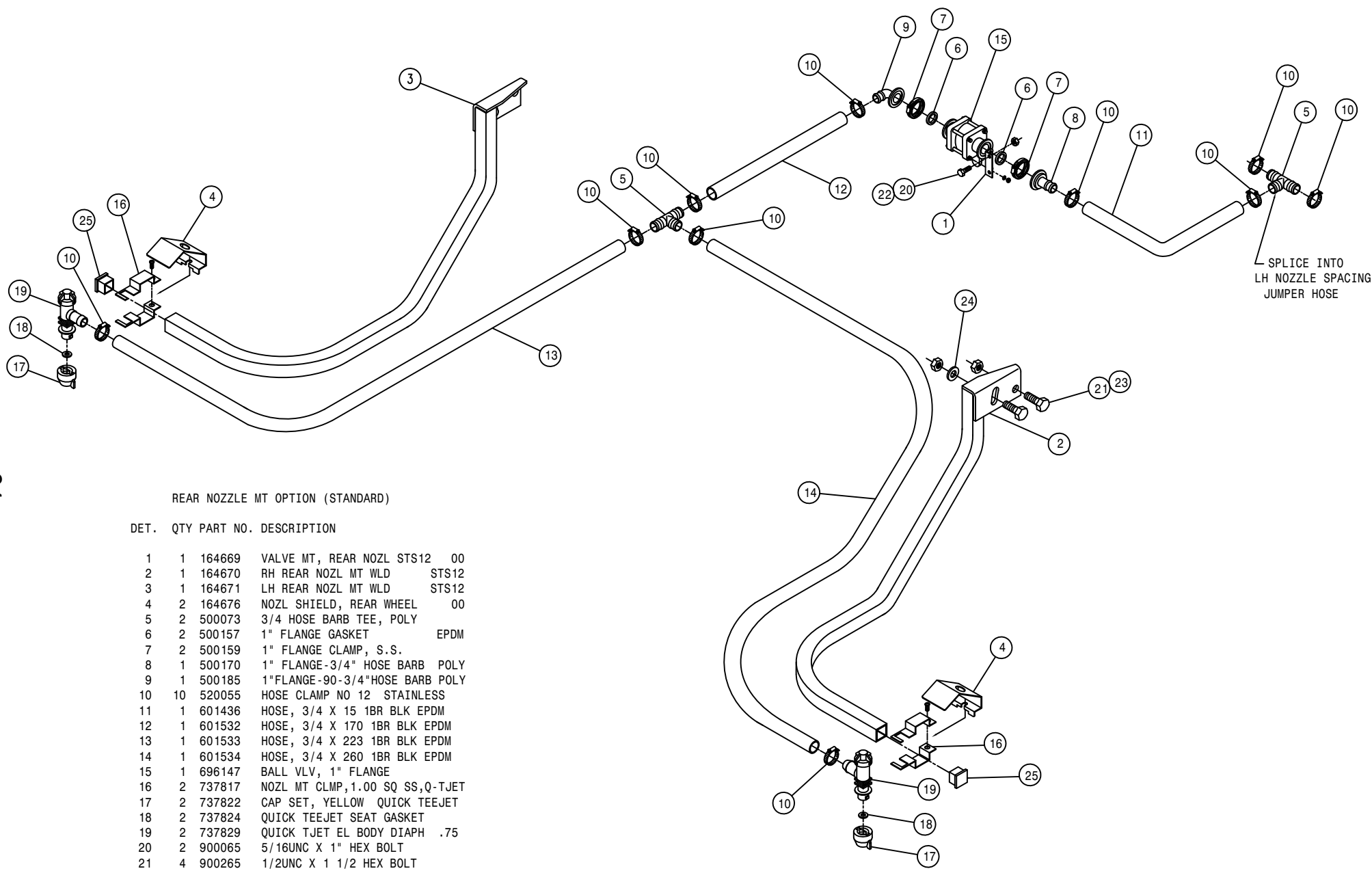

REAR NOZZLE MT OPTION (STANDARD)

DET.	QTY	PART NO.	DESCRIPTION
1	1	164669	VALVE MT, REAR NOZL STS12 00
2	1	164670	RH REAR NOZL MT WLD STS12
3	1	164671	LH REAR NOZL MT WLD STS12
4	2	164676	NOZL SHIELD, REAR WHEEL 00
5	2	500073	3/4 HOSE BARB TEE, POLY
6	2	500157	1" FLANGE GASKET EPDM
7	2	500159	1" FLANGE CLAMP, S.S.
8	1	500170	1" FLANGE-3/4" HOSE BARB POLY
9	1	500185	1"FLANGE-90-3/4"HOSE BARB POLY
10	10	520055	HOSE CLAMP NO 12 STAINLESS
11	1	601436	HOSE, 3/4 X 15 1BR BLK EPDM
12	1	601532	HOSE, 3/4 X 170 1BR BLK EPDM
13	1	601533	HOSE, 3/4 X 223 1BR BLK EPDM
14	1	601534	HOSE, 3/4 X 260 1BR BLK EPDM
15	1	696147	BALL VLV, 1" FLANGE
16	2	737817	NOZL MT CLMP,1.00 SQ SS,Q-TJET
17	2	737822	CAP SET, YELLOW QUICK TEEJET
18	2	737824	QUICK TEEJET SEAT GASKET
19	2	737829	QUICK TJET EL BODY DIAPH .75
20	2	900065	5/16UNC X 1" HEX BOLT
21	4	900265	1/2UNC X 1 1/2 HEX BOLT
22	2	914002	5/16UNC HEX STOVER NUT
23	4	914008	1/2UNC HEX STOVER NUT
24	2	920004	1/2 SAE FLAT WASHER
25	2	629727	FINISH PLUG FOR 1 IN X 16 GA

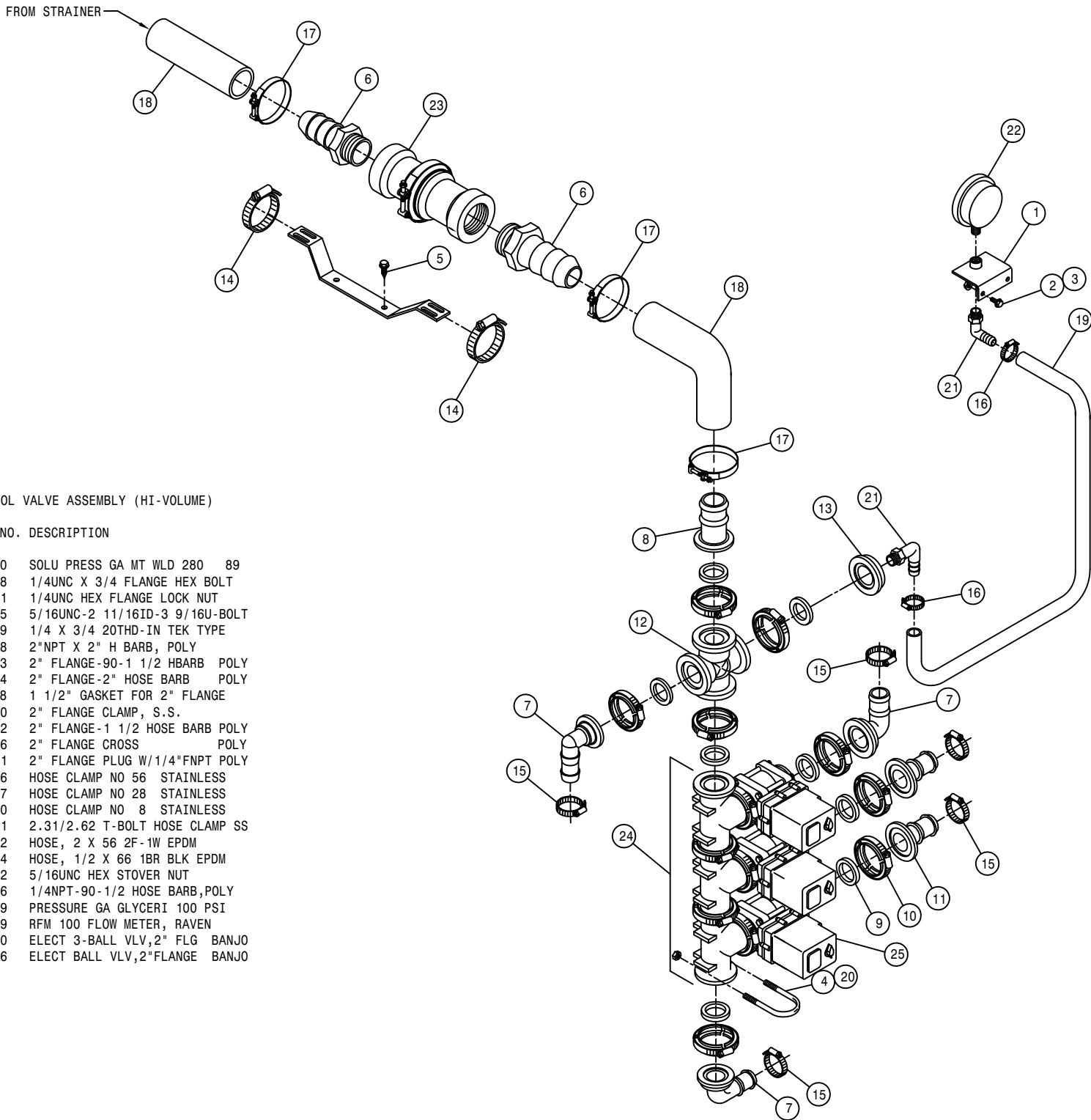

SOLUTION CONTROL VALVE ASSEMBLY (HI-VOLUME)

DET. QTY PART NO. DESCRIPTION

1	1	160010	SOLU PRESS GA MT WLD 280 89
2	2	470118	1/4UNC X 3/4 FLANGE HEX BOLT
3	2	470121	1/4UNC HEX FLANGE LOCK NUT
4	2	472195	5/16UNC-2 11/16ID-3 9/16U-BOLT
5	2	472349	1/4 X 3/4 20THD-IN TEK TYPE
6	2	500058	2"NPT X 2" H BARB, POLY
7	3	500153	2" FLANGE-90-1 1/2 HBARB POLY
8	1	500154	2" FLANGE-2" HOSE BARB POLY
9	8	500158	1 1/2" GASKET FOR 2" FLANGE
10	8	500160	2" FLANGE CLAMP, S.S.
11	2	500162	2" FLANGE-1 1/2 HOSE BARB POLY
12	1	500176	2" FLANGE CROSS POLY
13	1	500181	2" FLANGE PLUG W/1/4"FNPT POLY
14	2	520056	HOSE CLAMP NO 56 STAINLESS
15	5	520067	HOSE CLAMP NO 28 STAINLESS
16	2	520070	HOSE CLAMP NO 8 STAINLESS
17	3	520141	2.31/2.62 T-BOLT HOSE CLAMP SS
18	2	601502	HOSE, 2 X 56 2F-1W EPDM
19	1	601514	HOSE, 1/2 X 66 1BR BLK EPDM
20	4	914002	5/16UNC HEX STOVER NUT
21	2	618556	1/4NPT-90-1/2 HOSE BARB,POLY
22	1	690359	PRESSURE GA GLYCERI 100 PSI
23	1	690529	RFM 100 FLOW METER, RAVEN
24	1	696180	ELECT 3-BALL VLV,2" FLG BANJO
25	3	696176	ELECT BALL VLV,2"FLANGE BANJO

80'-90' SOLUTION VALVE ASSEMBLY (HI-VOLUME)

DET. QTY PART NO. DESCRIPTION

1	2	500158	1 1/2" GASKET FOR 2" FLANGE
2	2	500160	2" FLANGE CLAMP, S.S.
3	2	500162	2" FLANGE-1 1/2 HOSE BARB POLY
4	1	690745	2" SOLU VLV MT WLD
5	1	696176	ELECT BALL VLV, 2" FLANGE BANJO
6	2	520067	HOSE CLAMP NO 28 STAINLESS
7	1	520133	1.81/2.06 T-BOLT HOSE CLAMP SS

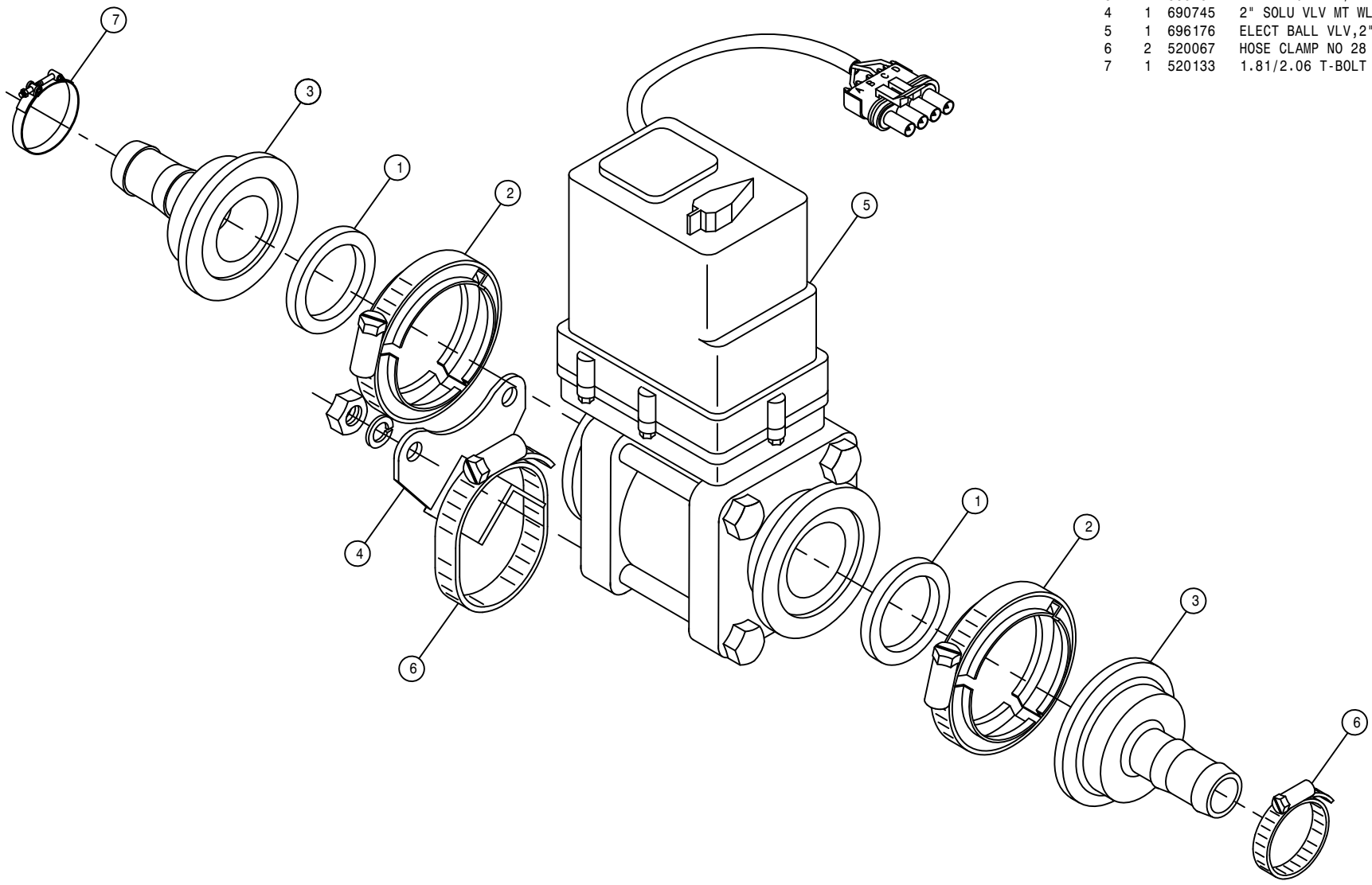

80'-90' FEEDER TEE ASSEMBLY (HI-VOLUME)

DET. QTY PART NO. DESCRIPTION

1	5	500158	1 1/2" GASKET FOR 2" FLANGE
2	5	500160	2" FLANGE CLAMP, S.S.
3	1	500162	2" FLANGE-1 1/2 HOSE BARB POLY
4	3	500172	2" FLANGE-1" HOSE BARB POLY
5	2	500151	2" FLANGE TEE POLY
6	3	520090	HOSE CLAMP NO 16 STAINLESS
7	1	520133	1.81/2.06 T-BOLT HOSE CLAMP SS

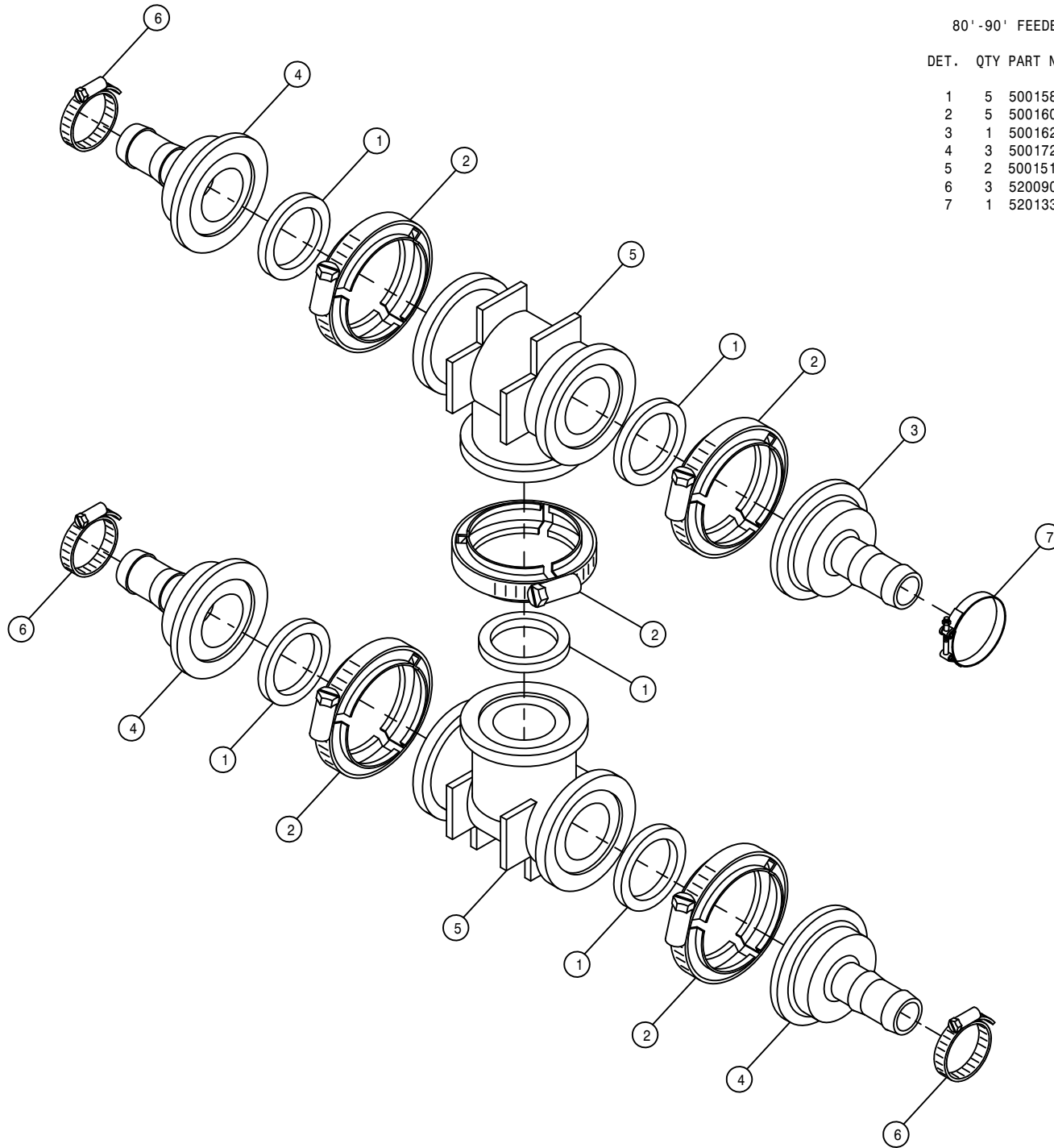

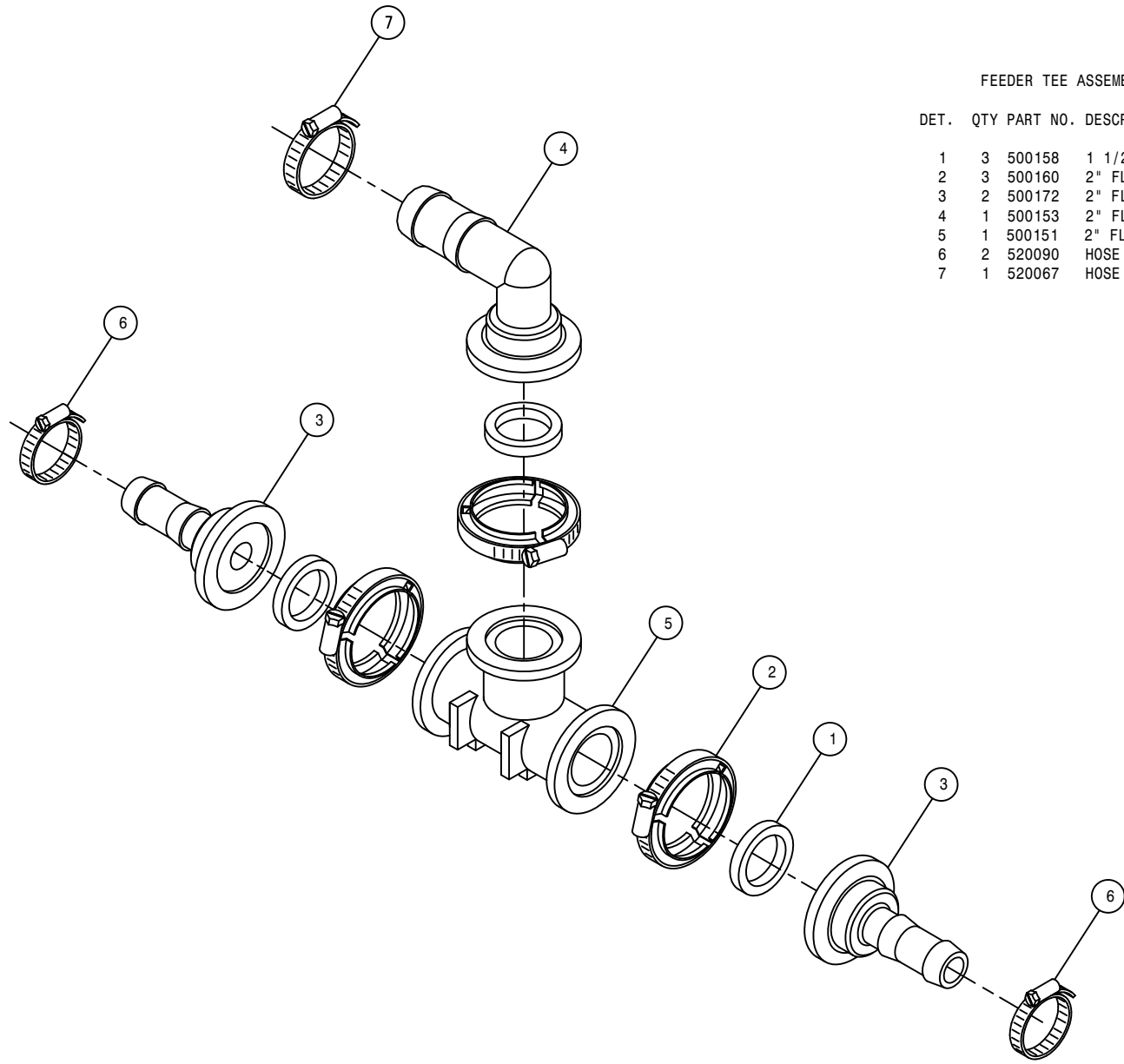

FEEDER TEE ASSEMBLY (HI-VOLUME)

DET.	QTY	PART NO.	DESCRIPTION
1	3	500158	1 1/2" GASKET FOR 2" FLANGE
2	3	500160	2" FLANGE CLAMP, S.S.
3	2	500172	2" FLANGE-1" HOSE BARB POLY
4	1	500153	2" FLANGE-90-1 1/2 HBARB POLY
5	1	500151	2" FLANGE TEE POLY
6	2	520090	HOSE CLAMP NO 16 STAINLESS
7	1	520067	HOSE CLAMP NO 28 STAINLESS

90° BALL VALVE ASSEMBLY (HI-VOLUME)

DET. QTY PART NO. DESCRIPTION

1	2	500157	1" FLANGE GASKET	EPDM
2	2	500159	1" FLANGE CLAMP, S.S.	
3	2	500171	1" FLANGE - 1" HOSE BARB	POLY
4	1	701191	1" SOLU VLV MT WLD	
5	1	696147	BALL VLV, 1" FLANGE	
6	1	520085	HOSE CLAMP NO 24	STAINLESS
7	2	520090	HOSE CLAMP NO 16	STAINLESS

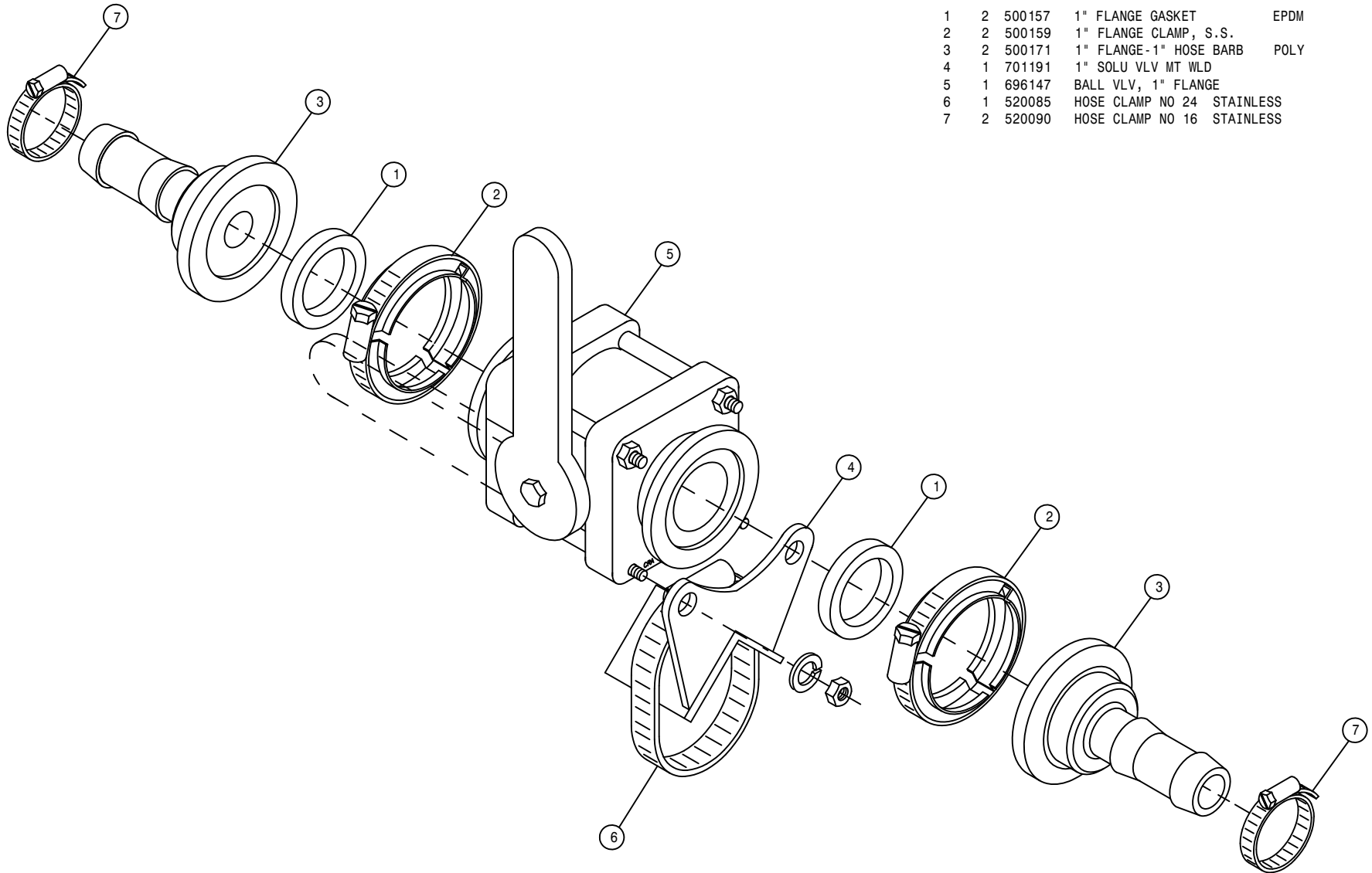

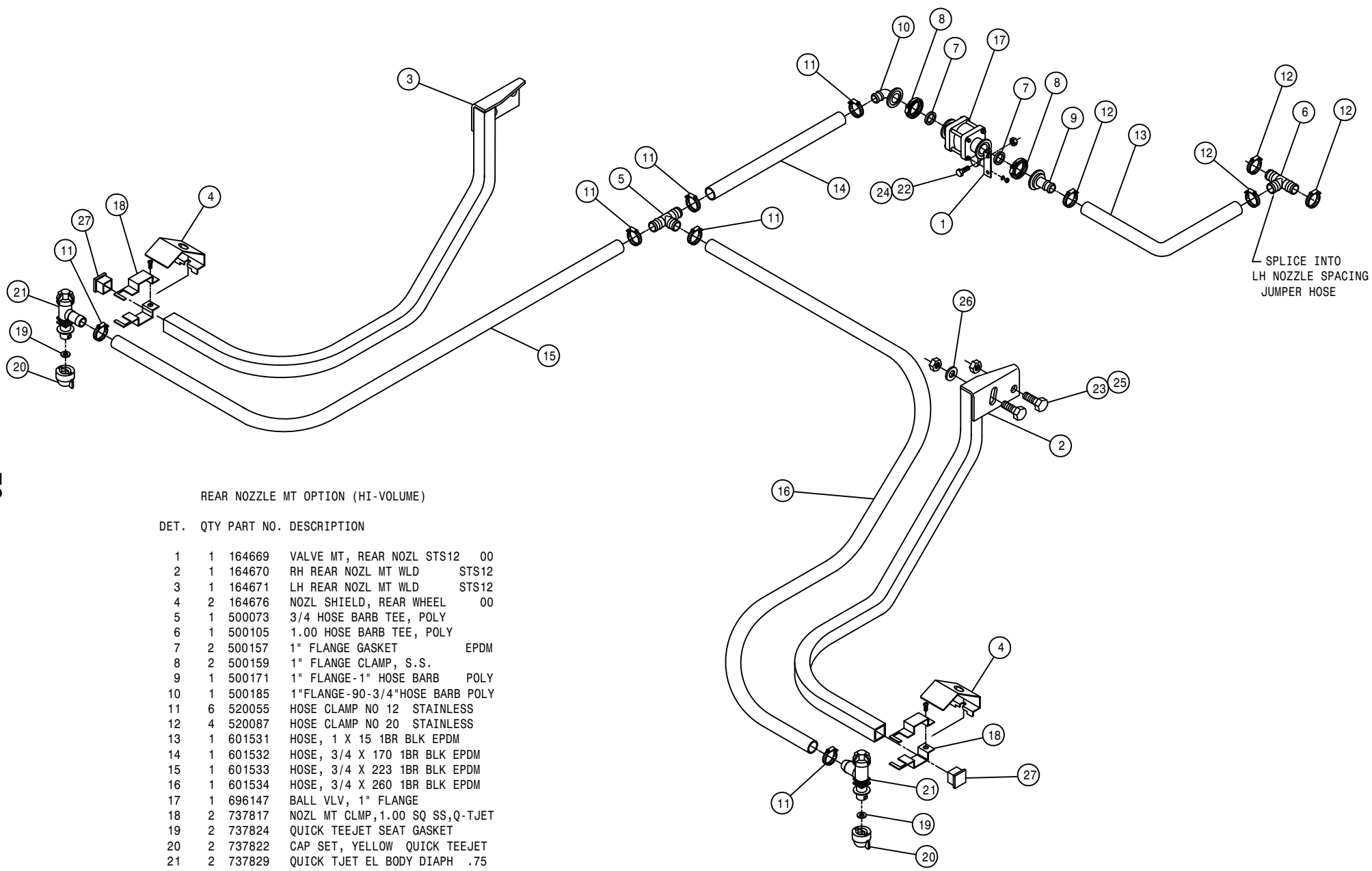

REAR NOZZLE MT OPTION (HI-VOLUME)

DET.	QTY	PART NO.	DESCRIPTION
1	1	164669	VALVE MT, REAR NOZL STS12 00
2	1	164670	RH REAR NOZL MT WLD STS12
3	1	164671	LH REAR NOZL MT WLD STS12
4	2	164676	NOZL SHIELD, REAR WHEEL 00
5	1	500073	3/4 HOSE BARB TEE, POLY
6	1	500105	1.00 HOSE BARB TEE, POLY
7	2	500157	1" FLANGE GASKET EPDM
8	2	500159	1" FLANGE CLAMP, S.S.
9	1	500171	1" FLANGE-1" HOSE BARB POLY
10	1	500185	1" FLANGE-90-3/4" HOSE BARB POLY
11	6	520055	HOSE CLAMP NO 12 STAINLESS
12	4	520087	HOSE CLAMP NO 20 STAINLESS
13	1	601531	HOSE, 1 X 15 1BR BLK EPDM
14	1	601532	HOSE, 3/4 X 170 1BR BLK EPDM
15	1	601533	HOSE, 3/4 X 223 1BR BLK EPDM
16	1	601534	HOSE, 3/4 X 260 1BR BLK EPDM
17	1	696147	BALL VLV, 1" FLANGE
18	2	737817	NOZL MT CLMP, 1.00 SQ SS, Q-TJET
19	2	737824	QUICK TEEJET SEAT GASKET
20	2	737822	CAP SET, YELLOW QUICK TEEJET
21	2	737829	QUICK TJET EL BODY DIAPH .75
22	2	900065	5/16UNC X 1" HEX BOLT
23	4	900265	1/2UNC X 1 1/2 HEX BOLT
24	2	914002	5/16UNC HEX STOVER NUT
25	4	914008	1/2UNC HEX STOVER NUT
26	2	920004	1/2 SAE FLAT WASHER
27	2	629727	FINISH PLUG FOR 1 IN X 16 GA

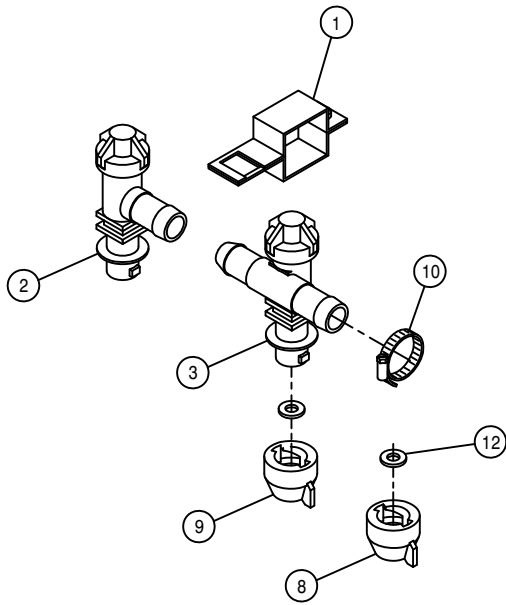

STANDARD SINGLE TIP SPACING

BOOM NOZZLE BODY

DET. QTY PART NO. DESCRIPTION

1	3	737817	NOZL MT CLMP, 1.00 SQ SS, Q-TJET
2	1	737829	QUICK TJET EL BODY DIAPH .75
3	1	737830	QUICK TJET TEE BODY DIAPH .75
4	1	737833	QUICK TJET LBO, 3-TIP BODY .75
5	1	737834	QUICK TJET TEE, 3-TIP BODY .75
6	1	737900	QUICK TJET LBO, 3-TIP BODY 1.00
7	1	737901	QUICK TJET TEE, 3-TIP BODY 1.00
8	3	737825	QUICK TEEJET SHUT-OFF CAP
9	3	737822	CAP SET, YELLOW QUICK TEEJET
10	2	520055	HOSE CLAMP NO 12 STAINLESS
11	1	520090	HOSE CLAMP NO 16 STAINLESS
12	6	737824	QUICK TEEJET SEAT GASKET

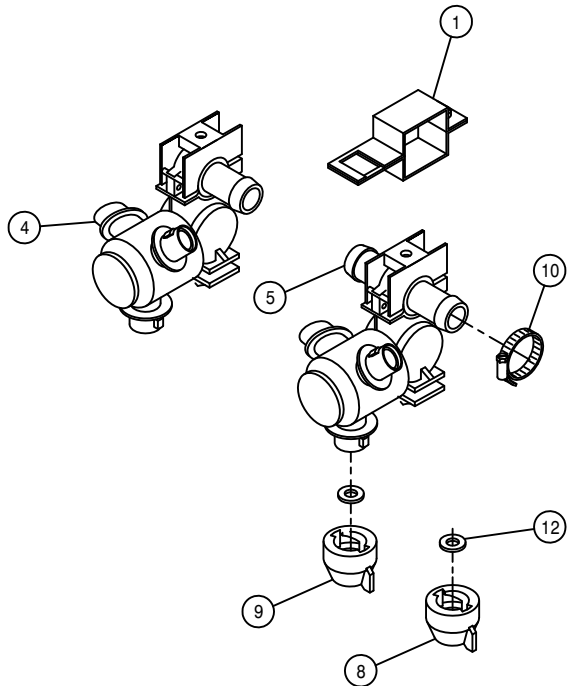

STANDARD TRIPLE TIP SPACING

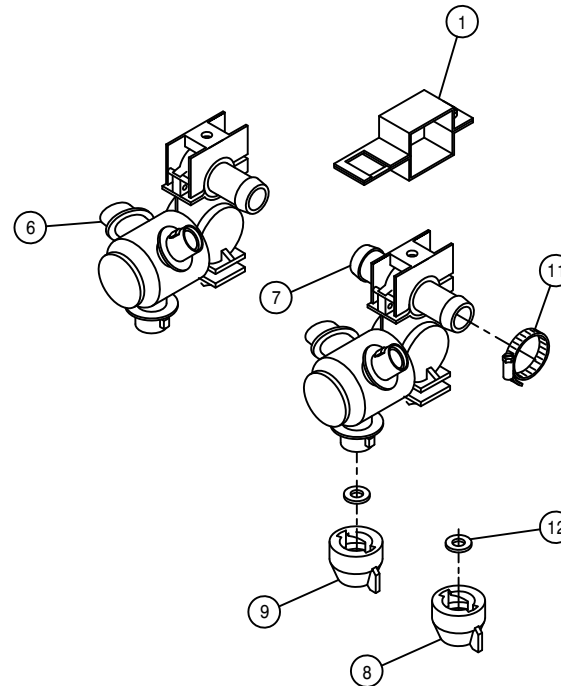

HI-VOLUME TRIPLE TIP SPACING

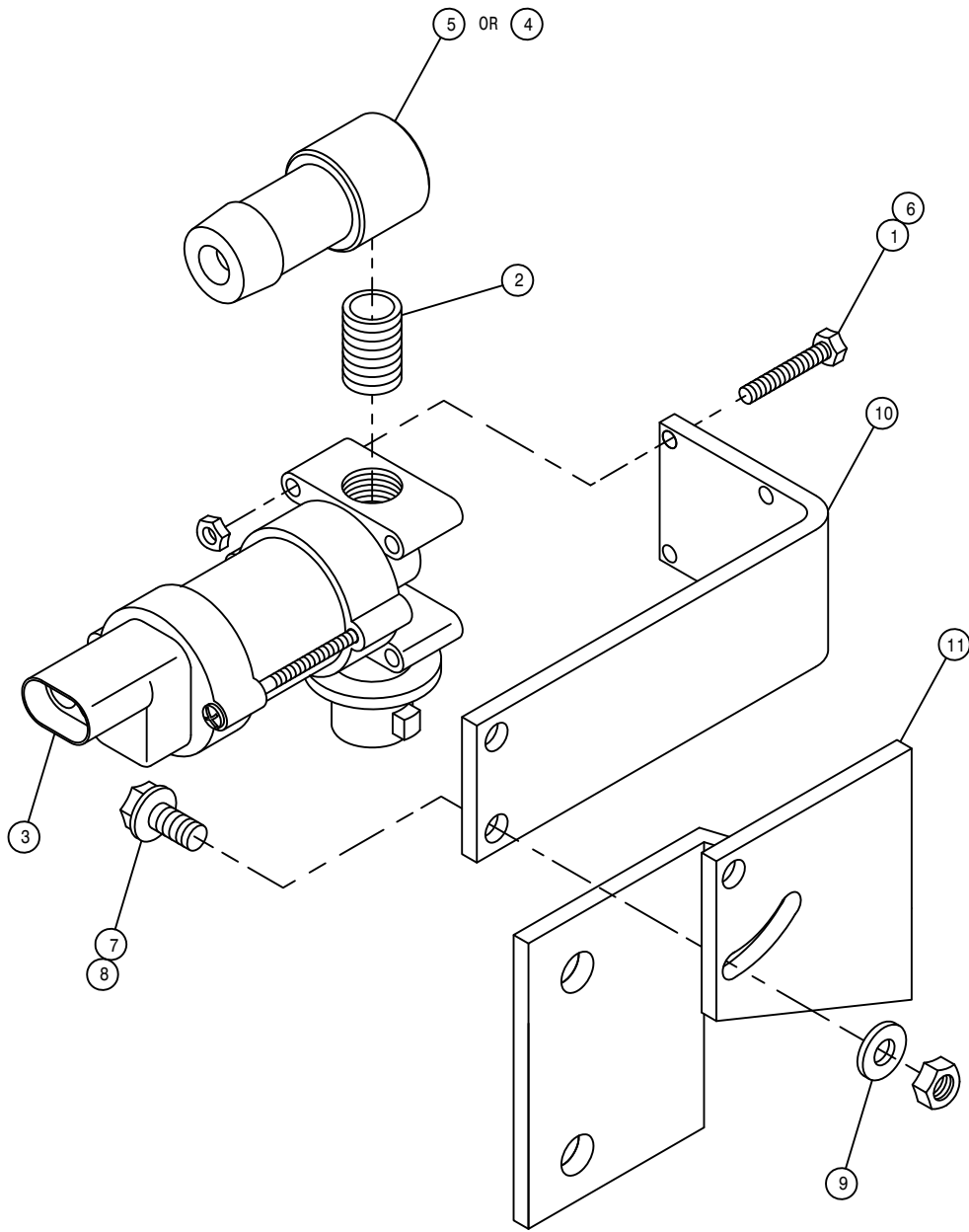

RH FENCE ROW NOZZLE ASSEMBLY

DET. QTY PART NO. DESCRIPTION

1	4	473993	6-32 X 1 1/4 HH MACH SCR
2	1	507022	SS CLOSE PIPE NIPPLE, .25MNPT
3	1	737875	NOZZLE BODY VALVE, 12VDC
4	1	737876	1.00 FENCE ROW NOZZLE HOSEBARB
5	1	737878	.75 FENCE ROW NOZZLE HOSEBARB
6	4	910022	6-32 HEX NUT
7	2	470118	1/4UNC X 3/4 FLANGE HEX BOLT
8	2	914000	1/4UNC HEX STOVER NUT
9	1	920000	1/4 SAE FLAT WASHER
10	1	737906	FENCE ROW NOZL BRKT
11	1	737907	RH FENCE ROW TIP BRKT MT

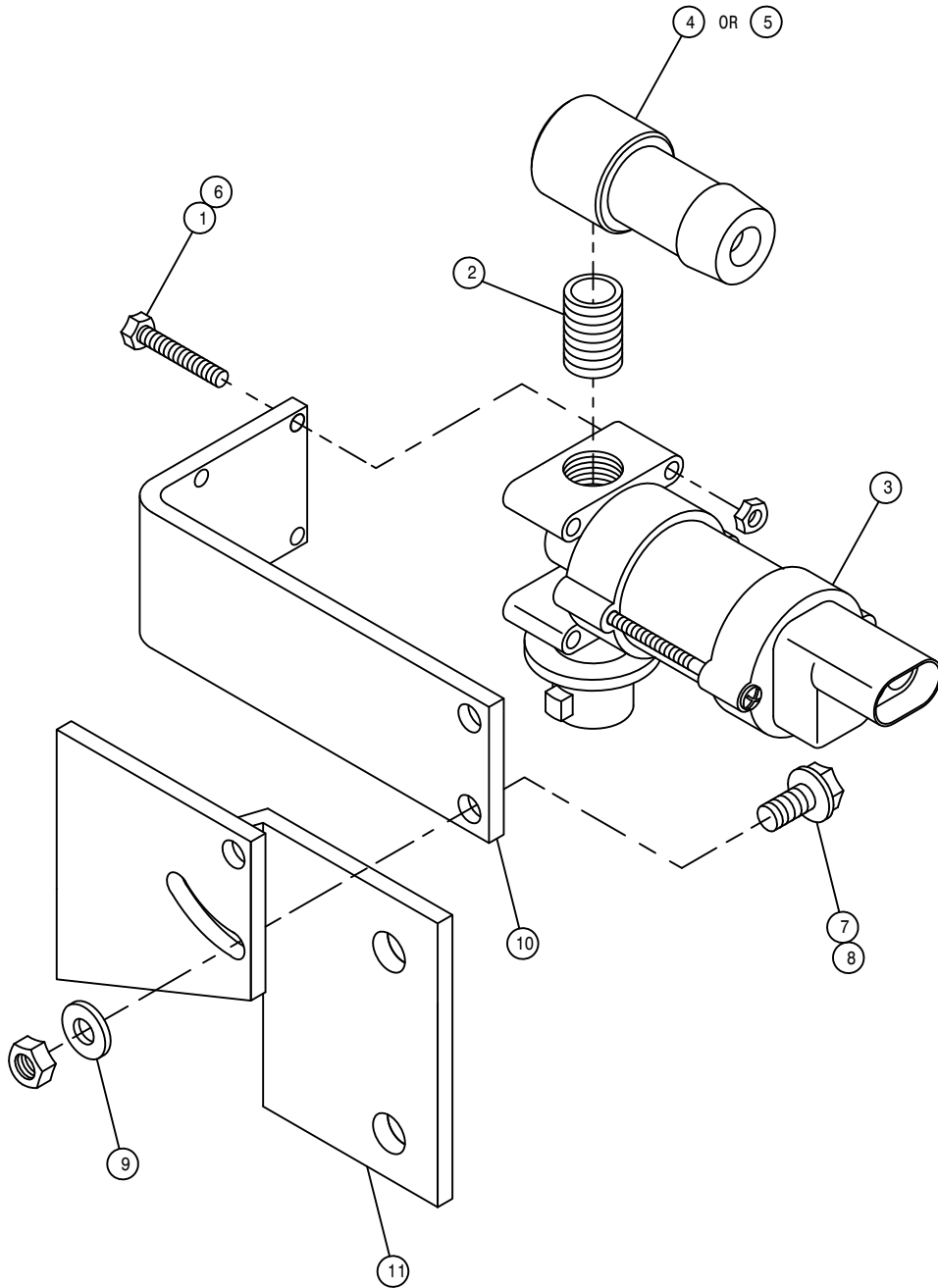

LH FENCE ROW NOZZLE ASSEMBLY

DET. QTY PART NO. DESCRIPTION

1	4	473993	6-32 X 1 1/4 HH MACH SCR
2	1	507022	SS CLOSE PIPE NIPPLE, .25MNPT
3	1	737875	NOZZLE BODY VALVE, 12VDC
4	1	737876	1.00 FENCE ROW NOZZLE HOSEBARB
5	1	737878	.75 FENCE ROW NOZZLE HOSEBARB
6	4	910022	6-32 HEX NUT
7	2	470118	1/4UNC X 3/4 FLANGE HEX BOLT
8	2	914000	1/4UNC HEX STOVER NUT
9	1	920000	1/4 SAE FLAT WASHER
10	1	737906	FENCE ROW NOZL BRKT
11	1	737908	LH FENCE ROW TIP BRKT MT

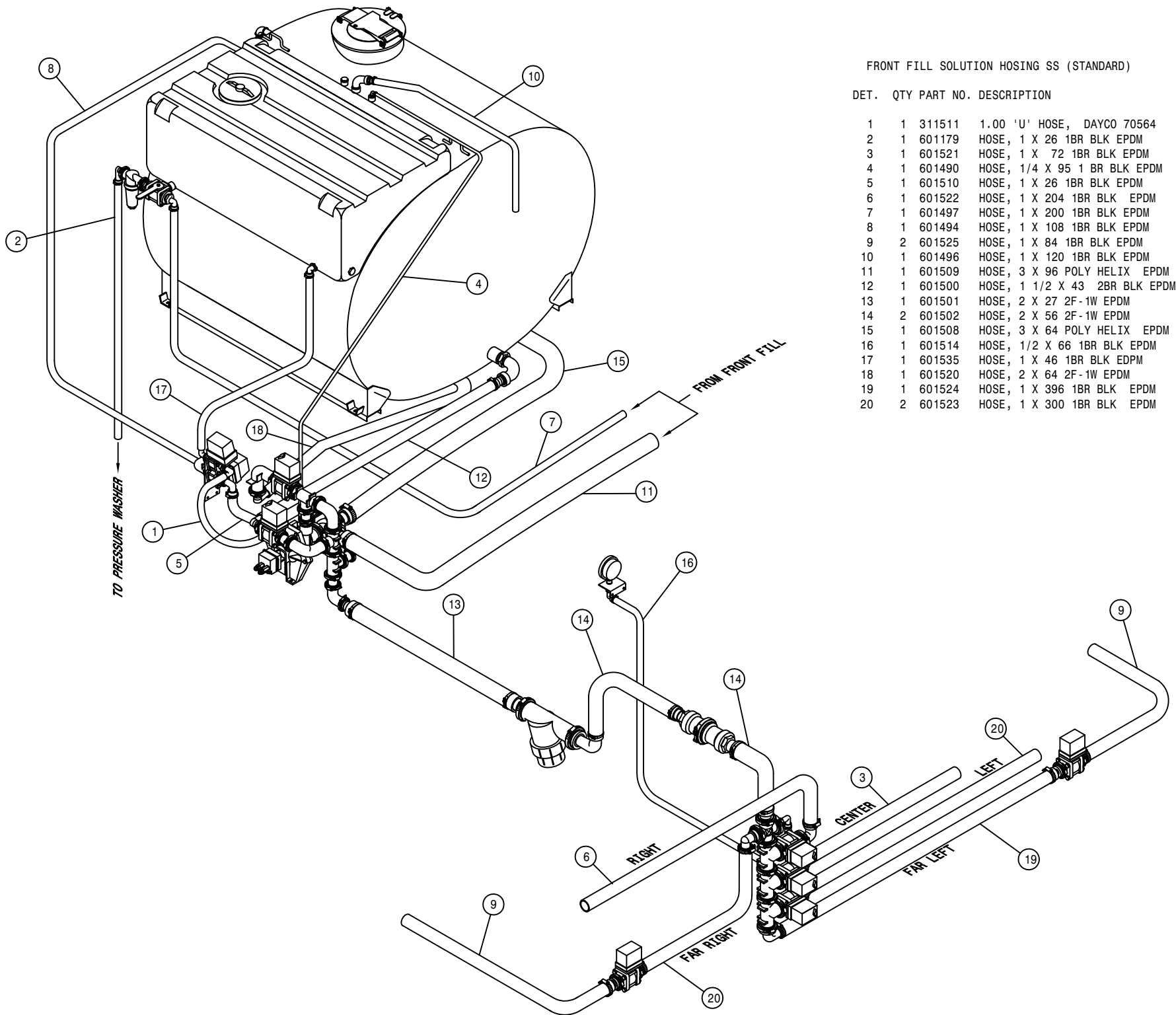

FRONT FILL SOLUTION HOISING SS (STANDARD)

DET.	QTY	PART NO.	DESCRIPTION
1	1	311511	1.00 'U' HOSE, DAYCO 70564
2	1	601179	HOSE, 1 X 26 1BR BLK EPDM
3	1	601521	HOSE, 1 X 72 1BR BLK EPDM
4	1	601490	HOSE, 1/4 X 95 1 BR BLK EPDM
5	1	601510	HOSE, 1 X 26 1BR BLK EPDM
6	1	601522	HOSE, 1 X 204 1BR BLK EPDM
7	1	601497	HOSE, 1 X 200 1BR BLK EPDM
8	1	601494	HOSE, 1 X 108 1BR BLK EPDM
9	2	601525	HOSE, 1 X 84 1BR BLK EPDM
10	1	601496	HOSE, 1 X 120 1BR BLK EPDM
11	1	601509	HOSE, 3 X 96 POLY HELIX EPDM
12	1	601500	HOSE, 1 1/2 X 43 2BR BLK EPDM
13	1	601501	HOSE, 2 X 27 2F-1W EPDM
14	2	601502	HOSE, 2 X 56 2F-1W EPDM
15	1	601508	HOSE, 3 X 64 POLY HELIX EPDM
16	1	601514	HOSE, 1/2 X 66 1BR BLK EPDM
17	1	601535	HOSE, 1 X 46 1BR BLK EPDM
18	1	601520	HOSE, 2 X 64 2F-1W EPDM
19	1	601524	HOSE, 1 X 396 1BR BLK EPDM
20	2	601523	HOSE, 1 X 300 1BR BLK EPDM

FRONT FILL SOLUTION HOISING POLY (STANDARD)

DET. QTY PART NO. DESCRIPTION

DET.	QTY	PART NO.	DESCRIPTION
1	1	311511	1.00 'U' HOSE, DAYCO 70564
2	1	601179	HOSE, 1 X 26 1BR BLK EPDM
3	1	601521	HOSE, 1 X 72 1BR BLK EPDM
4	1	601490	HOSE, 1/4 X 95 1 BR BLK EPDM
5	1	601510	HOSE, 1 X 26 1BR BLK EPDM
6	1	601522	HOSE, 1 X 204 1BR BLK EPDM
7	1	601497	HOSE, 1 X 200 1BR BLK EPDM
8	1	601494	HOSE, 1 X 108 1BR BLK EPDM
9	2	601525	HOSE, 1 X 84 1BR BLK EPDM
10	1	601556	HOSE, 1 X 48 1BR BLK EDPM
11	1	601509	HOSE, 3 X 96 POLY HELIX EPDM
12	1	601557	HOSE, 1 X 114 1BR BLK EDPM
13	1	601501	HOSE, 2 X 27 2F-1W EPDM
14	2	601502	HOSE, 2 X 56 2F-1W EPDM
15	1	601508	HOSE, 3 X 64 POLY HELIX EPDM
16	1	601514	HOSE, 1/2 X 66 1BR BLK EPDM
17	1	601535	HOSE, 1 X 46 1BR BLK EPDM
18	1	601520	HOSE, 2 X 64 2F-1W EPDM
19	1	601524	HOSE, 1 X 396 1BR BLK EPDM
20	2	601523	HOSE, 1 X 300 1BR BLK EPDM
21	1	601558	HOSE, 1" X 24 CLEAR VINYL
22	1	601559	HOSE, 1" X 36 CLEAR VINYL
23	1	601560	HOSE, 1" X 49 CLEAR VINYL

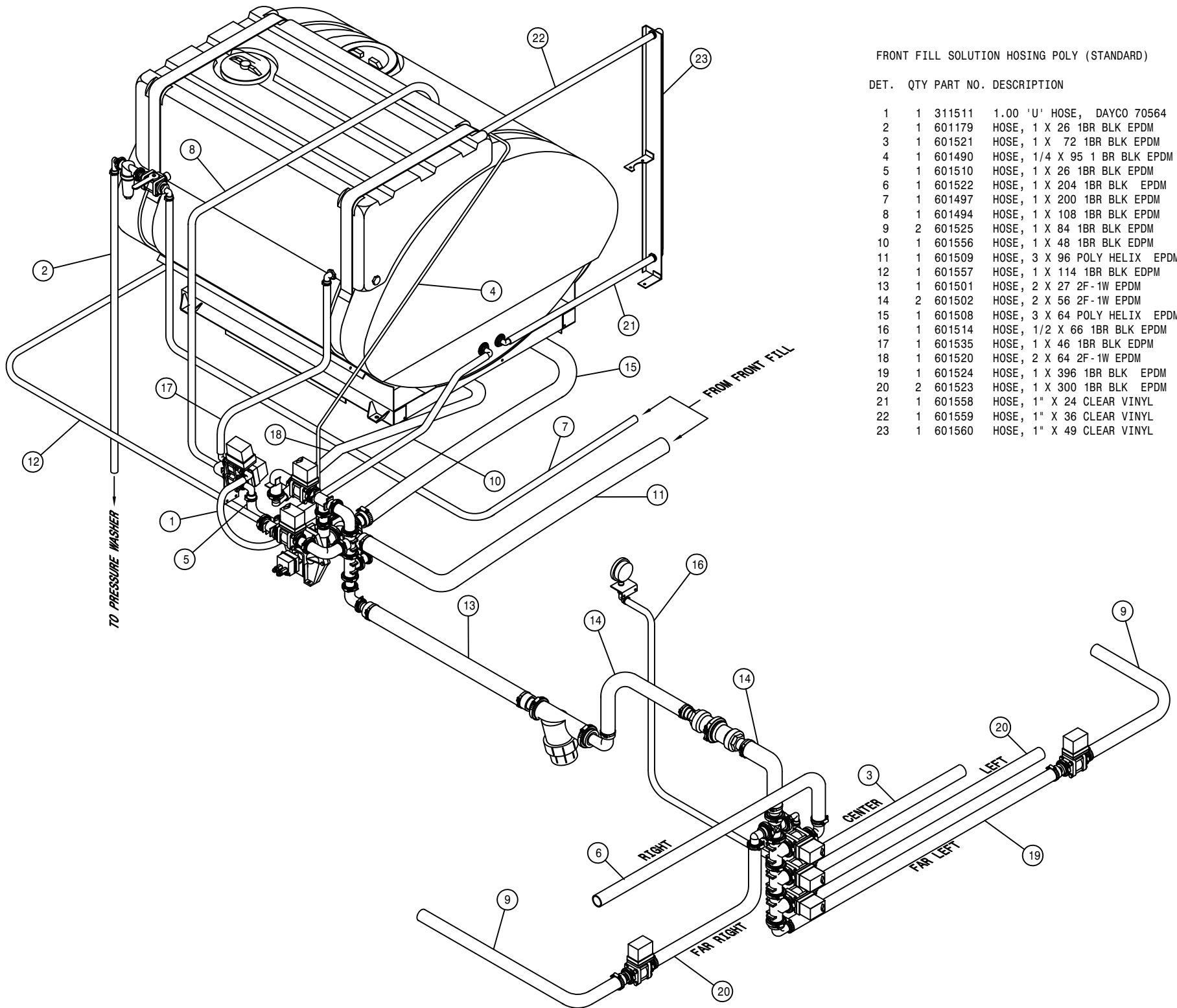

SIDE FILL SOLUTION HOISING SS (STANDARD)

DET. QTY PART NO. DESCRIPTION

1	1	311511	1.00 'U' HOSE, DAYCO 70564
2	1	601179	HOSE, 1 X 26 1BR BLK EPDM
3	2	601523	HOSE, 1 X 300 1BR BLK EPDM
4	1	601490	HOSE, 1/4 X 95 1 BR BLK EPDM
5	1	601510	HOSE, 1 X 26 1BR BLK EPDM
6	1	601521	HOSE, 1 X 72 1BR BLK EPDM
7	1	601459	HOSE, 1 X 245 1BR BLK EPDM
8	1	601494	HOSE, 1 X 108 1BR BLK EPDM
9	1	601522	HOSE, 1 X 204 1BR BLK EPDM
10	1	601496	HOSE, 1 X 120 1BR BLK EPDM
11	2	601525	HOSE, 1 X 84 1BR BLK EPDM
12	1	601500	HOSE, 1 1/2 X 43 2BR BLK EPDM
13	1	601501	HOSE, 2 X 27 2F-1W EPDM
14	2	601502	HOSE, 2 X 56 2F-1W EPDM
15	1	601503	HOSE, 3 X 8 POLY HELIX EPDM
16	1	601504	HOSE, 3 X 22 POLY HELIX EPDM
17	1	601505	HOSE, 3 X 40 POLY HELIX EPDM
18	1	601506	HOSE, 3 X 74 POLY HELIX EPDM
19	1	601514	HOSE, 1/2 X 66 1BR BLK EPDM
20	1	601535	HOSE, 1 X 46 1BR BLK EPDM
21	1	601520	HOSE, 2 X 64 2F-1W EPDM
22	1	601524	HOSE, 1 X 396 1BR BLK EPDM

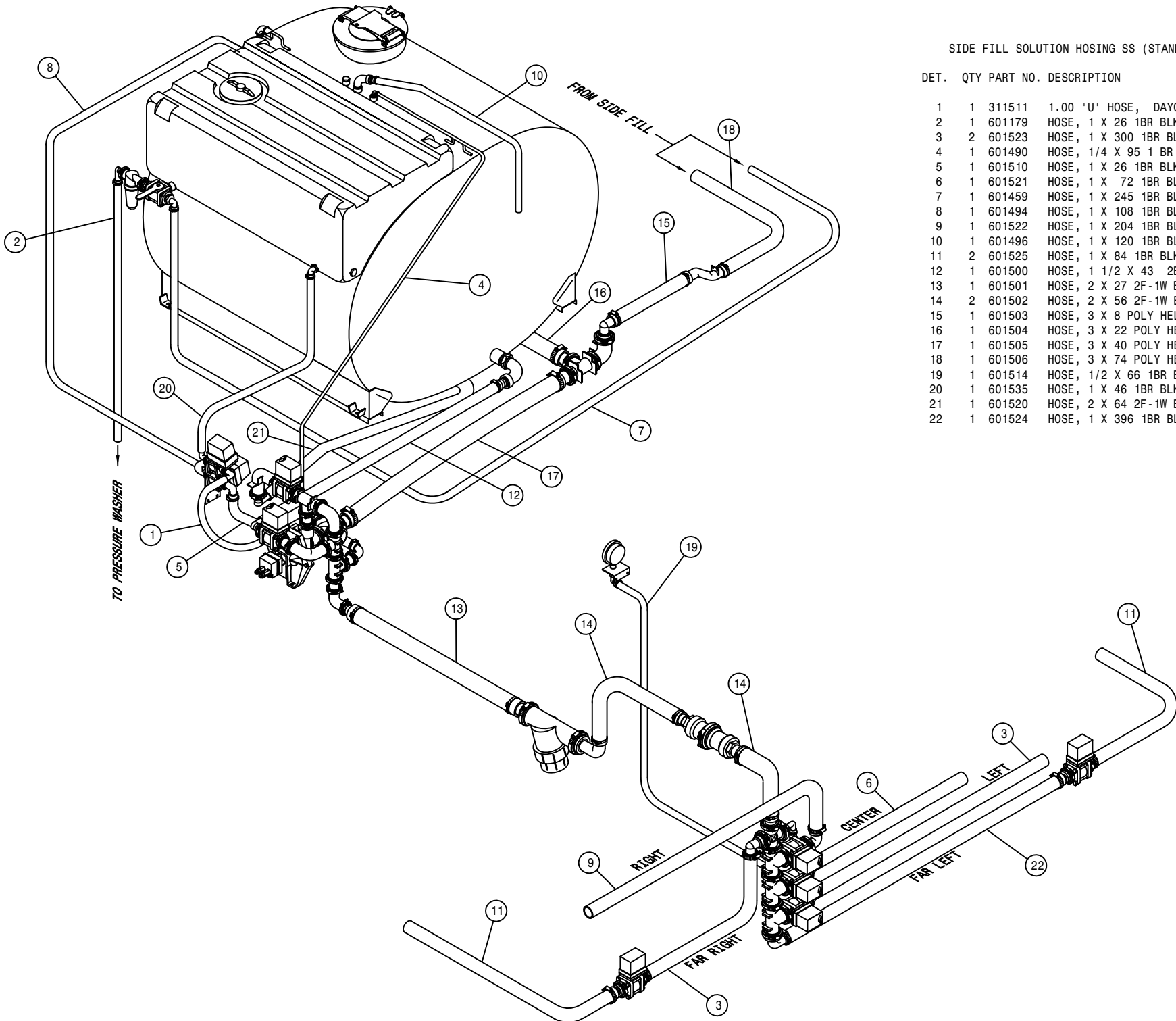

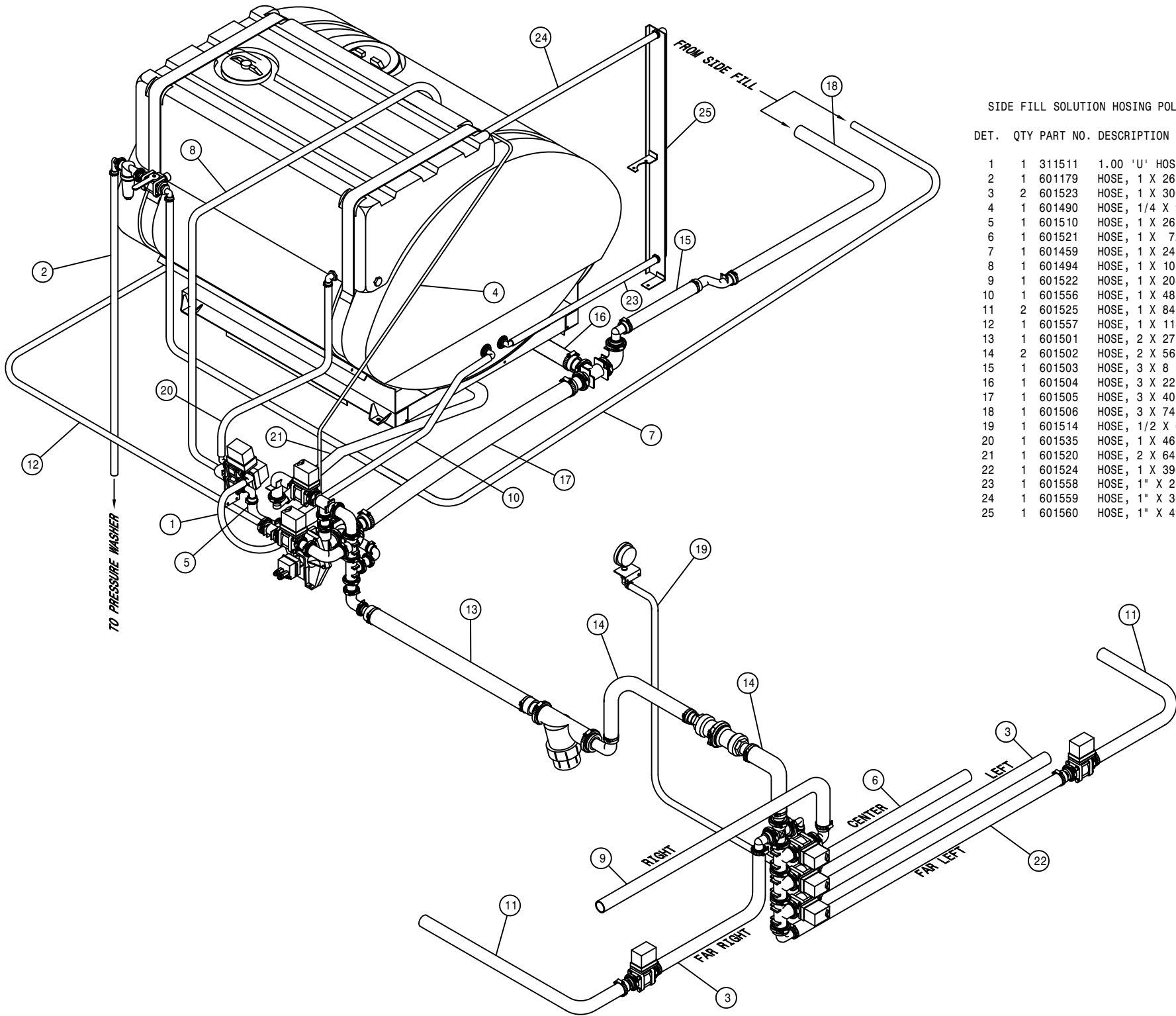

SIDE FILL SOLUTION HOISING POLY (STANDARD)

DET.	QTY	PART NO.	DESCRIPTION
1	1	311511	1.00 'U' HOSE, DAYCO 70564
2	1	601179	HOSE, 1 X 26 1BR BLK EPDM
3	2	601523	HOSE, 1 X 300 1BR BLK EPDM
4	1	601490	HOSE, 1/4 X 95 1 BR BLK EPDM
5	1	601510	HOSE, 1 X 26 1BR BLK EPDM
6	1	601521	HOSE, 1 X 72 1BR BLK EPDM
7	1	601459	HOSE, 1 X 245 1BR BLK EPDM
8	1	601494	HOSE, 1 X 108 1BR BLK EPDM
9	1	601522	HOSE, 1 X 204 1BR BLK EPDM
10	1	601556	HOSE, 1 X 48 1BR BLK EPDM
11	2	601525	HOSE, 1 X 84 1BR BLK EPDM
12	1	601557	HOSE, 1 X 114 1BR BLK EPDM
13	1	601501	HOSE, 2 X 27 2F-1W EPDM
14	2	601502	HOSE, 2 X 56 2F-1W EPDM
15	1	601503	HOSE, 3 X 8 POLY HELIX EPDM
16	1	601504	HOSE, 3 X 22 POLY HELIX EPDM
17	1	601505	HOSE, 3 X 40 POLY HELIX EPDM
18	1	601506	HOSE, 3 X 74 POLY HELIX EPDM
19	1	601514	HOSE, 1/2 X 66 1BR BLK EPDM
20	1	601535	HOSE, 1 X 46 1BR BLK EPDM
21	1	601520	HOSE, 2 X 64 2F-1W EPDM
22	1	601524	HOSE, 1 X 396 1BR BLK EPDM
23	1	601558	HOSE, 1" X 24 CLEAR VINYL
24	1	601559	HOSE, 1" X 36 CLEAR VINYL
25	1	601560	HOSE, 1" X 49 CLEAR VINYL

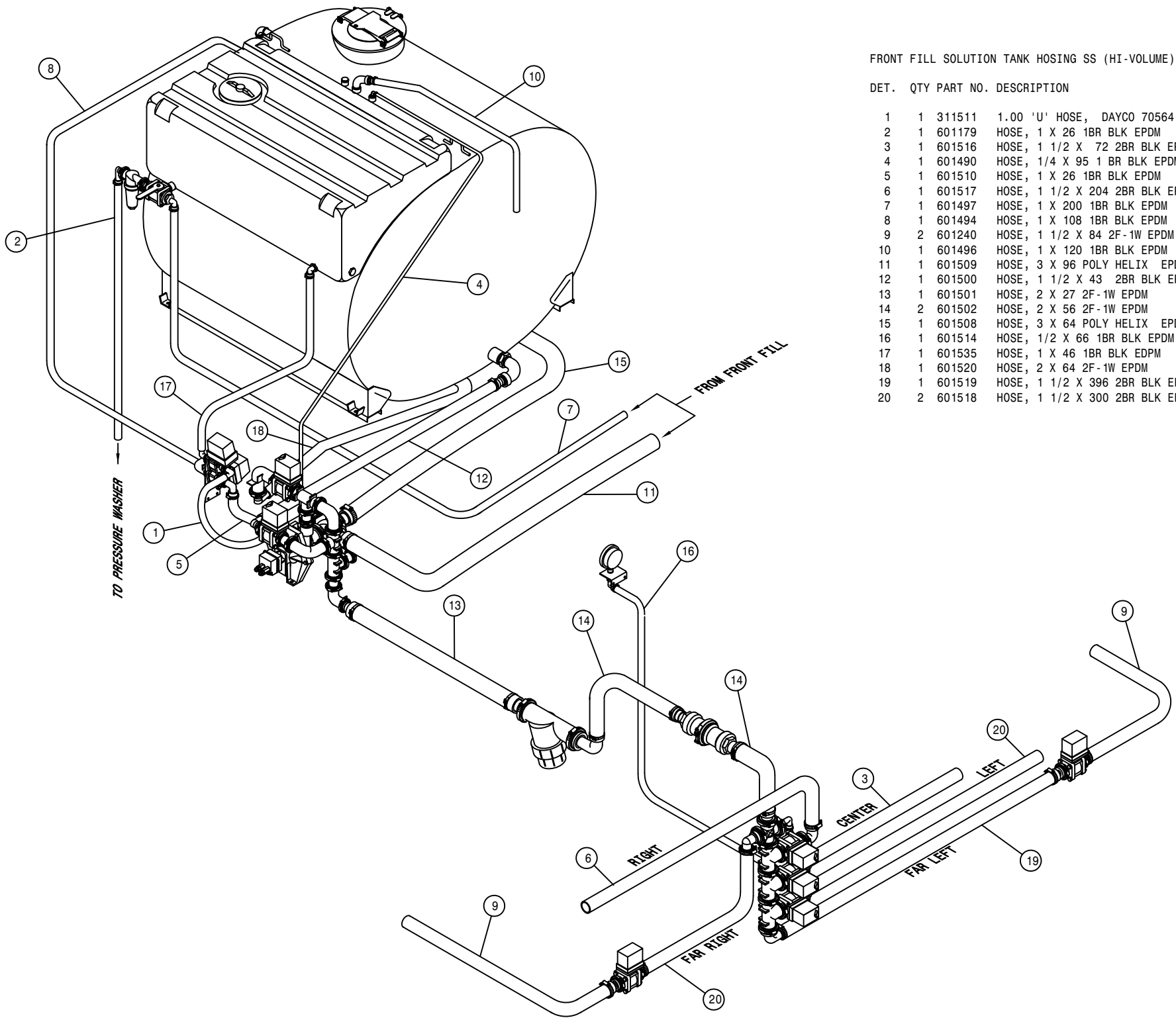

FRONT FILL SOLUTION TANK HOISING SS (HI-VOLUME)

DET. QTY PART NO. DESCRIPTION

1	1	311511	1.00 'U' HOSE, DAYCO 70564
2	1	601179	HOSE, 1 X 26 1BR BLK EPDM
3	1	601516	HOSE, 1 1/2 X 72 2BR BLK EPDM
4	1	601490	HOSE, 1/4 X 95 1 BR BLK EPDM
5	1	601510	HOSE, 1 X 26 1BR BLK EPDM
6	1	601517	HOSE, 1 1/2 X 204 2BR BLK EPDM
7	1	601497	HOSE, 1 X 200 1BR BLK EPDM
8	1	601494	HOSE, 1 X 108 1BR BLK EPDM
9	2	601240	HOSE, 1 1/2 X 84 2F-1W EPDM
10	1	601496	HOSE, 1 X 120 1BR BLK EPDM
11	1	601509	HOSE, 3 X 96 POLY HELIX EPDM
12	1	601500	HOSE, 1 1/2 X 43 2BR BLK EPDM
13	1	601501	HOSE, 2 X 27 2F-1W EPDM
14	2	601502	HOSE, 2 X 56 2F-1W EPDM
15	1	601508	HOSE, 3 X 64 POLY HELIX EPDM
16	1	601514	HOSE, 1/2 X 66 1BR BLK EPDM
17	1	601535	HOSE, 1 X 46 1BR BLK EPDM
18	1	601520	HOSE, 2 X 64 2F-1W EPDM
19	1	601519	HOSE, 1 1/2 X 396 2BR BLK EPDM
20	2	601518	HOSE, 1 1/2 X 300 2BR BLK EPDM

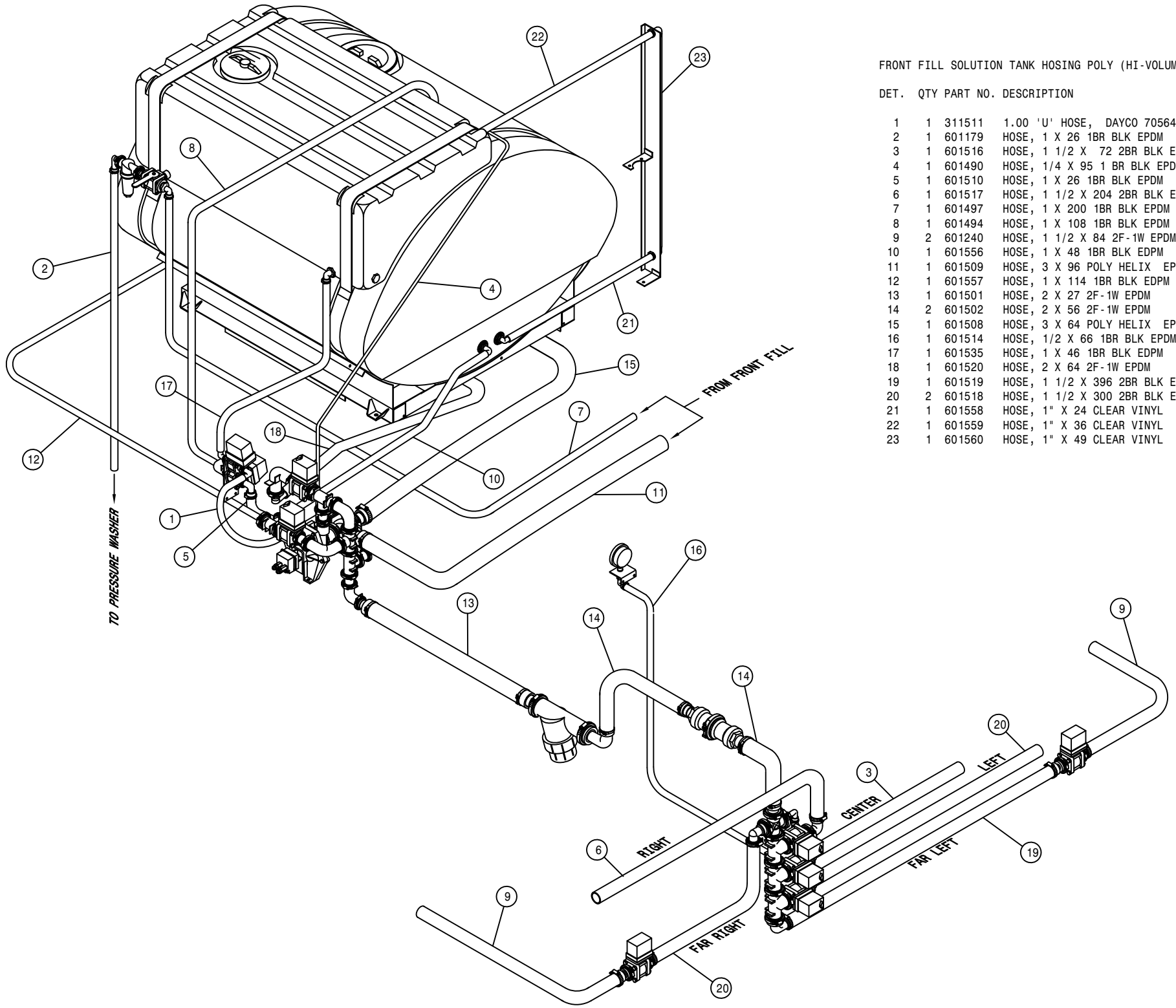

FRONT FILL SOLUTION TANK HOISING POLY (HI-VOLUME)

DET. QTY PART NO. DESCRIPTION

1	1	311511	1.00 'U' HOSE, DAYCO 70564
2	1	601179	HOSE, 1 X 26 1BR BLK EPDM
3	1	601516	HOSE, 1 1/2 X 72 2BR BLK EPDM
4	1	601490	HOSE, 1/4 X 95 1 BR BLK EPDM
5	1	601510	HOSE, 1 X 26 1BR BLK EPDM
6	1	601517	HOSE, 1 1/2 X 204 2BR BLK EPDM
7	1	601497	HOSE, 1 X 200 1BR BLK EPDM
8	1	601494	HOSE, 1 X 108 1BR BLK EPDM
9	2	601240	HOSE, 1 1/2 X 84 2F-1W EPDM
10	1	601556	HOSE, 1 X 48 1BR BLK EPDM
11	1	601509	HOSE, 3 X 96 POLY HELIX EPDM
12	1	601557	HOSE, 1 X 114 1BR BLK EPDM
13	1	601501	HOSE, 2 X 27 2F-1W EPDM
14	2	601502	HOSE, 2 X 56 2F-1W EPDM
15	1	601508	HOSE, 3 X 64 POLY HELIX EPDM
16	1	601514	HOSE, 1/2 X 66 1BR BLK EPDM
17	1	601535	HOSE, 1 X 46 1BR BLK EPDM
18	1	601520	HOSE, 2 X 64 2F-1W EPDM
19	1	601519	HOSE, 1 1/2 X 396 2BR BLK EPDM
20	2	601518	HOSE, 1 1/2 X 300 2BR BLK EPDM
21	1	601558	HOSE, 1" X 24 CLEAR VINYL
22	1	601559	HOSE, 1" X 36 CLEAR VINYL
23	1	601560	HOSE, 1" X 49 CLEAR VINYL

SIDE FILL SOLUTION HOISING SS (HI-VOLUME)

DET. QTY PART NO. DESCRIPTION

DET.	QTY	PART NO.	DESCRIPTION
1	1	311511	1.00 'U' HOSE, DAYCO 70564
2	1	601179	HOSE, 1 X 26 1BR BLK EPDM
3	2	601518	HOSE, 1 1/2 X 300 2BR BLK EPDM
4	1	601490	HOSE, 1/4 X 95 1 BR BLK EPDM
5	1	601510	HOSE, 1 X 26 1BR BLK EPDM
6	1	601516	HOSE, 1 1/2 X 72 2BR BLK EPDM
7	1	601459	HOSE, 1 X 245 1BR BLK EPDM
8	1	601494	HOSE, 1 X 108 1BR BLK EPDM
9	1	601517	HOSE, 1 1/2 X 204 2BR BLK EPDM
10	1	601496	HOSE, 1 X 120 1BR BLK EPDM
11	2	601240	HOSE, 1 1/2 X 84 2F-1W EPDM
12	1	601500	HOSE, 1 1/2 X 43 2BR BLK EPDM
13	1	601501	HOSE, 2 X 27 2F-1W EPDM
14	2	601502	HOSE, 2 X 56 2F-1W EPDM
15	1	601503	HOSE, 3 X 8 POLY HELIX EPDM
16	1	601504	HOSE, 3 X 22 POLY HELIX EPDM
17	1	601505	HOSE, 3 X 40 POLY HELIX EPDM
18	1	601506	HOSE, 3 X 74 POLY HELIX EPDM
19	1	601514	HOSE, 1/2 X 66 1BR BLK EPDM
20	1	601535	HOSE, 1 X 46 1BR BLK EPDM
21	1	601520	HOSE, 2 X 64 2F-1W EPDM
22	1	601519	HOSE, 1 1/2 X 396 2BR BLK EPDM

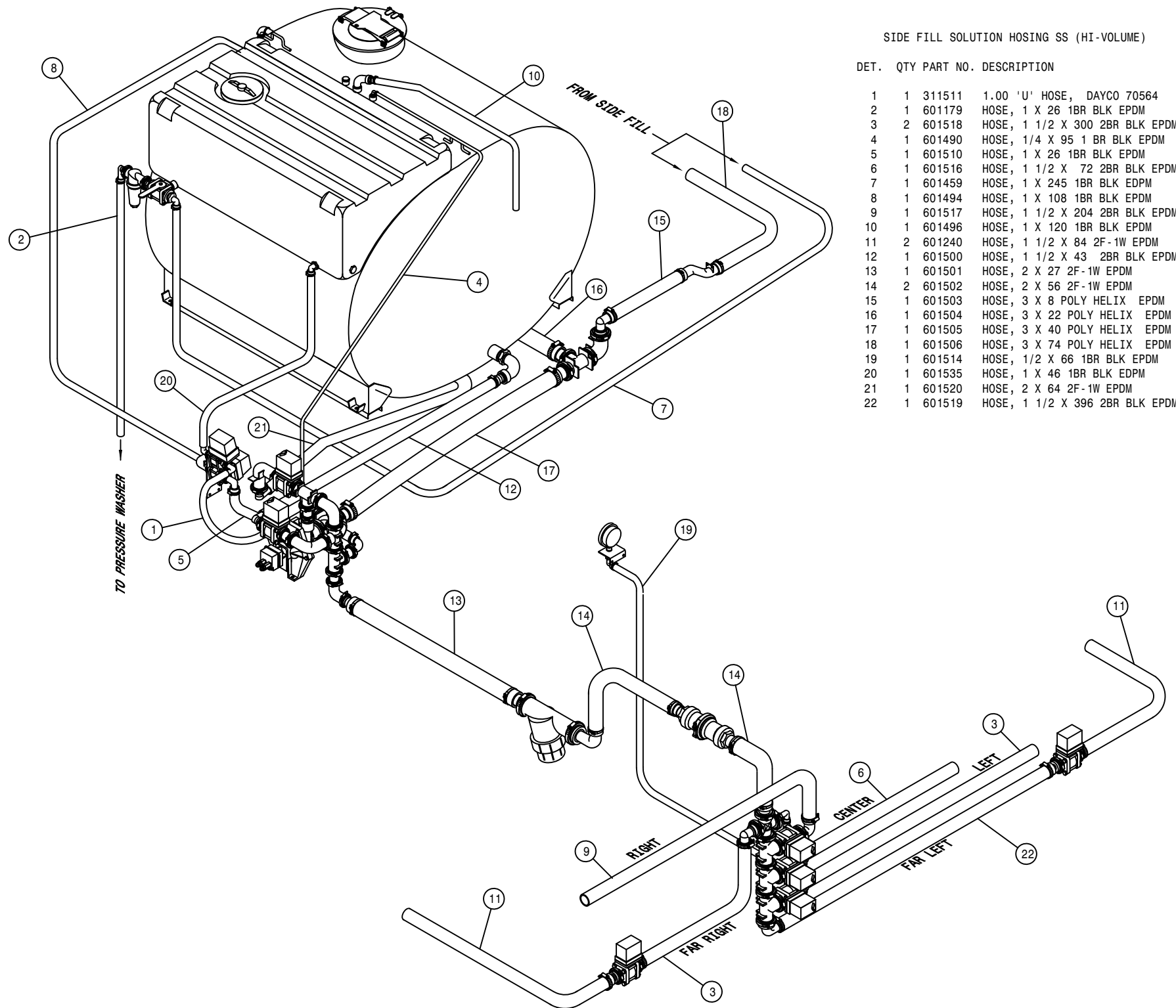

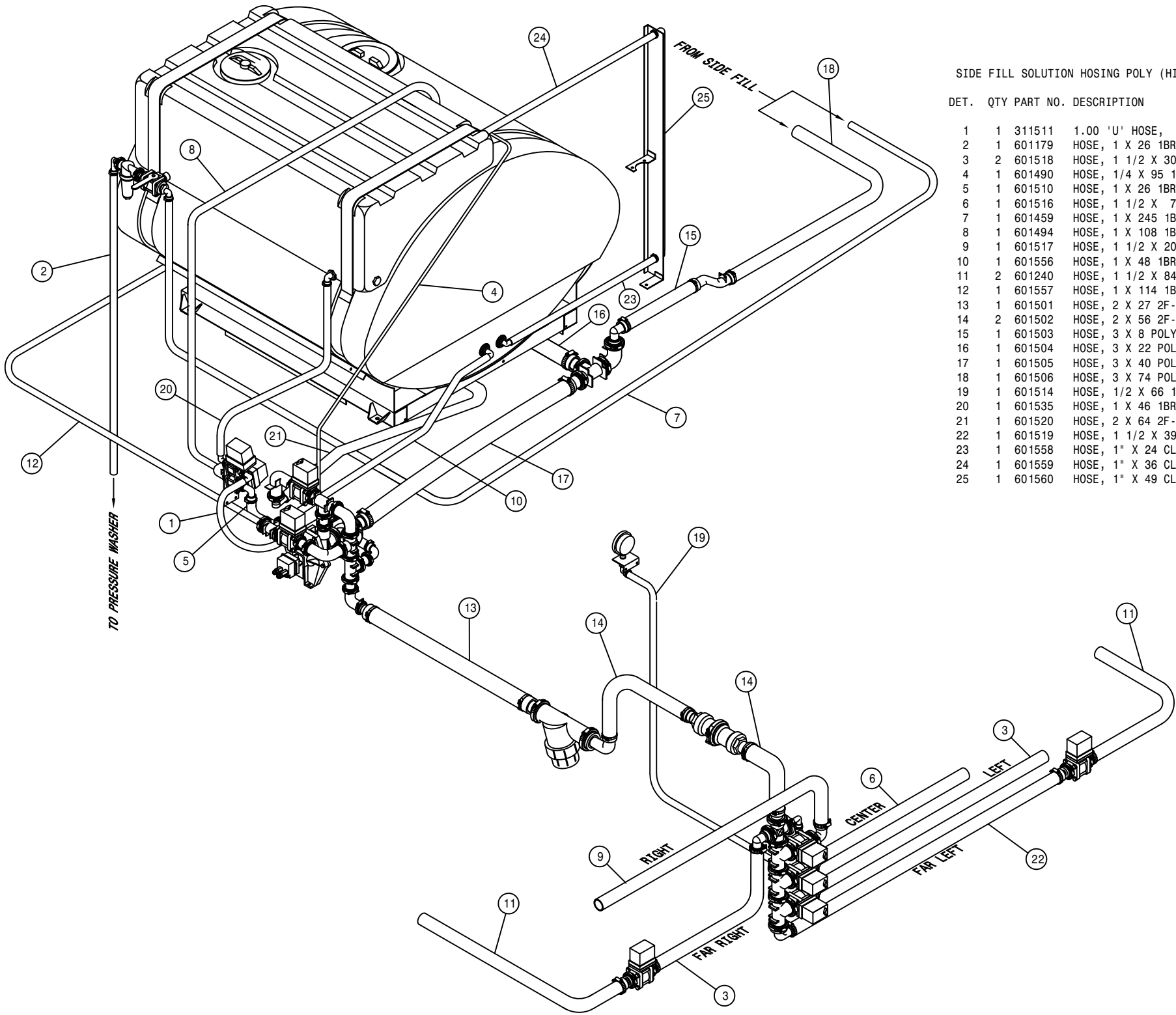

SIDE FILL SOLUTION HOISING POLY (HI-VOLUME)

DET.	QTY	PART NO.	DESCRIPTION
1	1	311511	1.00 'U' HOSE, DAYCO 70564
2	1	601179	HOSE, 1 X 26 1BR BLK EPDM
3	2	601518	HOSE, 1 1/2 X 300 2BR BLK EPDM
4	1	601490	HOSE, 1/4 X 95 1 BR BLK EPDM
5	1	601510	HOSE, 1 X 26 1BR BLK EPDM
6	1	601516	HOSE, 1 1/2 X 72 2BR BLK EPDM
7	1	601459	HOSE, 1 X 245 1BR BLK EPDM
8	1	601494	HOSE, 1 X 108 1BR BLK EPDM
9	1	601517	HOSE, 1 1/2 X 204 2BR BLK EPDM
10	1	601556	HOSE, 1 X 48 1BR BLK EPDM
11	2	601240	HOSE, 1 1/2 X 84 2F-1W EPDM
12	1	601557	HOSE, 1 X 114 1BR BLK EPDM
13	1	601501	HOSE, 2 X 27 2F-1W EPDM
14	2	601502	HOSE, 2 X 56 2F-1W EPDM
15	1	601503	HOSE, 3 X 8 POLY HELIX EPDM
16	1	601504	HOSE, 3 X 22 POLY HELIX EPDM
17	1	601505	HOSE, 3 X 40 POLY HELIX EPDM
18	1	601506	HOSE, 3 X 74 POLY HELIX EPDM
19	1	601514	HOSE, 1/2 X 66 1BR BLK EPDM
20	1	601535	HOSE, 1 X 46 1BR BLK EPDM
21	1	601520	HOSE, 2 X 64 2F-1W EPDM
22	1	601519	HOSE, 1 1/2 X 396 2BR BLK EPDM
23	1	601558	HOSE, 1" X 24 CLEAR VINYL
24	1	601559	HOSE, 1" X 36 CLEAR VINYL
25	1	601560	HOSE, 1" X 49 CLEAR VINYL

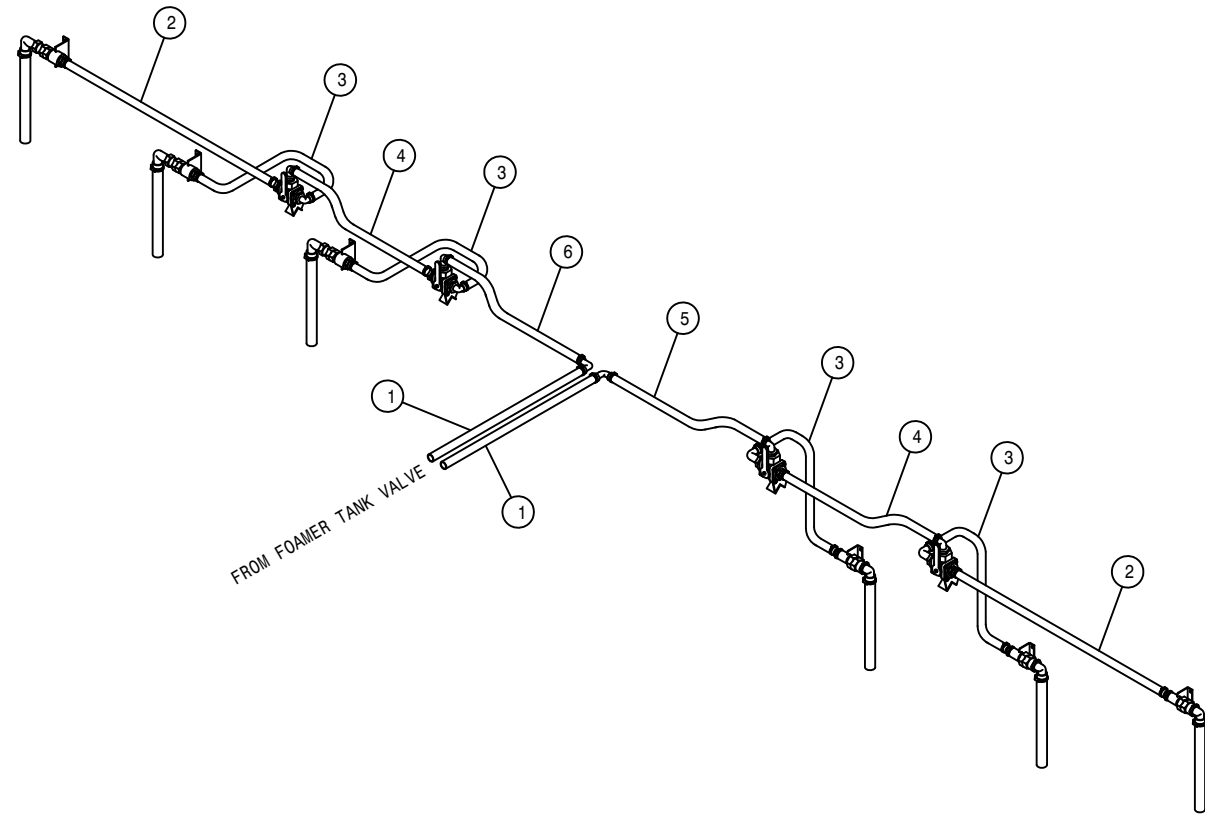

90' BOOM FOAMER HOSING

DET.	QTY	PART NO.	DESCRIPTION
1	2	195908	HOSE, 3/4ID-1/8W CLEAR VINYL X 206"
2	2	195908	HOSE, 3/4ID-1/8W CLEAR VINYL X 77"
3	4	195908	HOSE, 3/4ID-1/8W CLEAR VINYL X 24"
4	2	195908	HOSE, 3/4ID-1/8W CLEAR VINYL X 128"
5	1	195908	HOSE, 3/4ID-1/8W CLEAR VINYL X 420"
6	1	195908	HOSE, 3/4ID-1/8W CLEAR VINYL X 584"

FOAMER TANK ASSEMBLY

DET. QTY PART NO. DESCRIPTION

DET.	QTY	PART NO.	DESCRIPTION
1	2	195908	HOSE, 3/4ID-1/8W CLEAR VINYL X 206.00
2	1	601481	HOSE, 3/8 X 68 AIR
3	2	696181	3/4" ELECT SOLU SOLE VALVE 02
4	6	470294	RUBBER BUMPER, RECESS, .63H-1.5D
5	2	696207	.75 HOSE BARB-FEMALE COUPLER
6	1	505205	BLK PIPE NIPPLE 1.00NPT-5.00
7	2	505211	3/8-1/4NPT REDU BUSH, BRS
8	3	520120	HOSE CLAMP NO 4 STAINLESS
9	6	520055	HOSE CLAMP NO 12 STAINLESS
10	1	601419	HOSE, 3/8 X 30 CLEAR VINYL
11	1	601420	HOSE, 3/8 X 48 CLEAR VINYL
12	2	618571	1/4MNPT-90-1/4MNPT LBO
13	1	695900	BALL VALVE 1IN FNPT POLY
14	2	696120	BALL VALVE, 1/4NPT, STEEL
15	1	696134	BALL VALVE 2IN FNPT POLY
16	2	500043	3/4NPT PIPE PLUG, POLY
17	1	701112	FOAM MARKER TANK, 36 GAL SS
18	2	701214	1/2NPT-90-3/4HBRB, 1/4TAP, POLY
19	2	701215	1/4PIPE PLUG, .187 ORIFICE, POLY
20	1	711050	3/4"FNPT CHECK VALVE S.S.
21	1	711043	1/4MNPT-3/8 NYL TUBE SNGL LBO
22	1	783304	1/4 NPT X 3/8 HOSE BARB, BRS
23	6	900064	5/16UNC X 3/4 HEX BOLT
24	6	914002	5/16UNC HEX STOVER NUT
25	7	914008	1/2UNC HEX STOVER NUT
26	3	900264	1/2UNC X 1 1/4 HEX BOLT
27	1	701158	FOAMER TANK MT WLD STS12 2000
28	2	701170	FOAMER TANK STRAP ASSY
29	1	701144	FOAMER AIR NOZZLE
30	1	500202	SS PIPE CPLG, 1/8NPT .563 OD
31	1	507021	SS PIPE NIPPLE, 1/8NPT X 6"
32	1	701143	FOAMER AIR TUBE FTG
33	2	507724	REDU BUSH 3/4MNPT X 1/4FNPT, SS
34	2	500079	3/4NPT-90 EL, POLY
35	2	696208	.75 HOSE BARB-MALE COUPLER
36	2	696209	CAP FOR .75 MALE COUPLER POLY
37	2	696204	PLUG FOR .75 FEMALE COUPLER

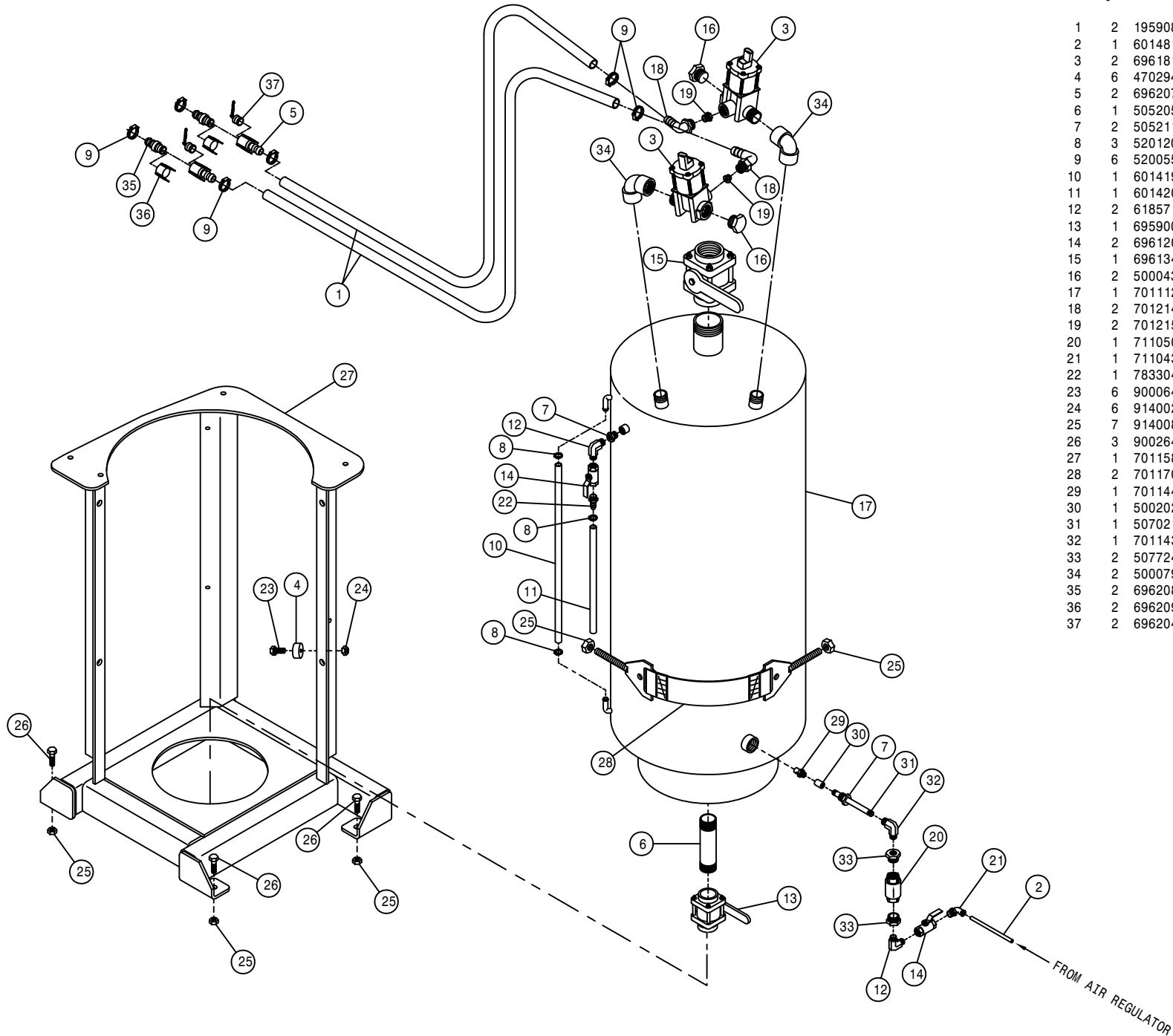

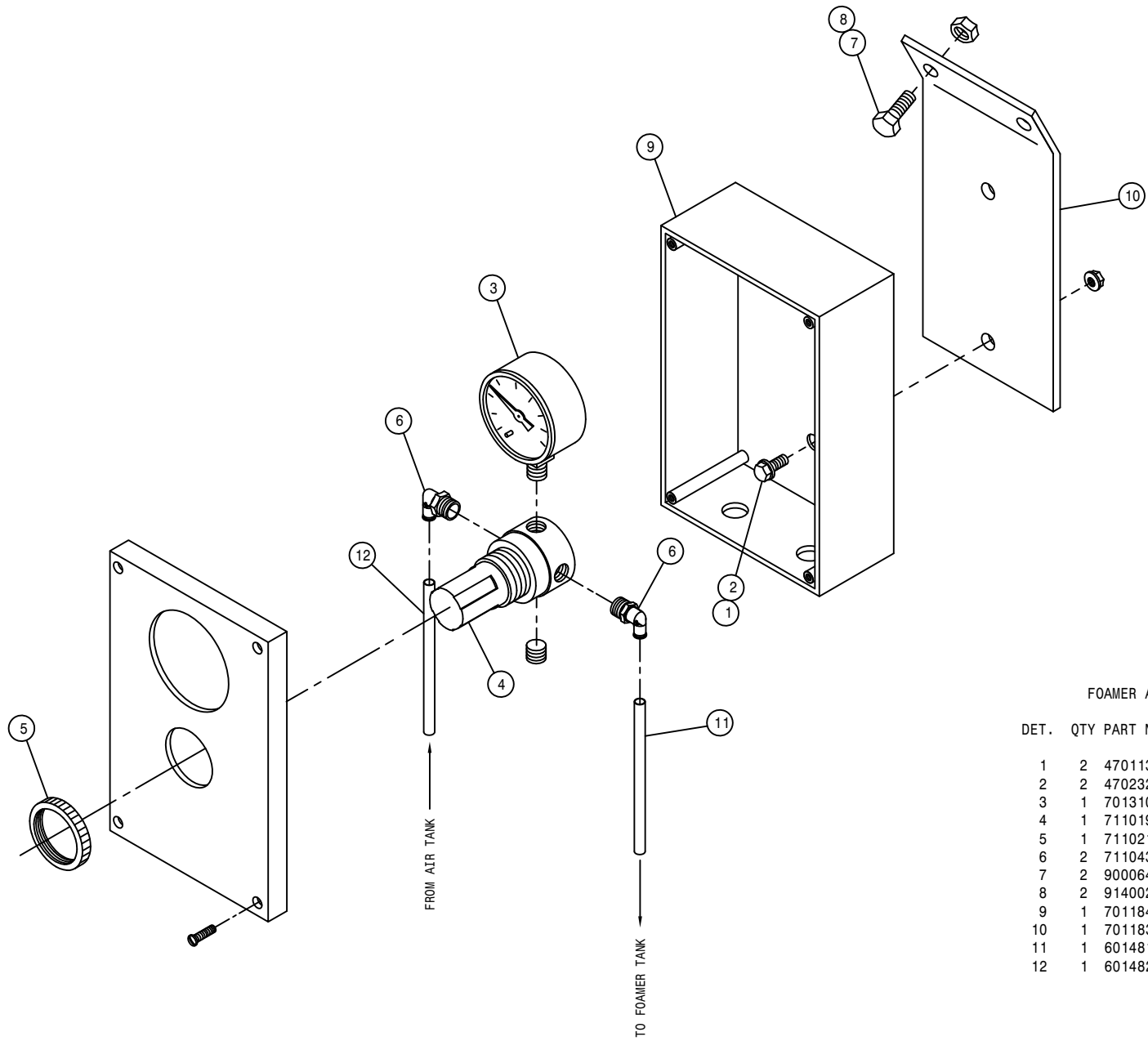

FOAMER AIR REGULATOR ASSEMBLY

DET.	QTY	PART NO.	DESCRIPTION
1	2	470113	5/16UNC HEX FLANGE LOCK NUT
2	2	470232	5/16UNC X 1/2 FLANGE HEX BOLT
3	1	701310	AIR PRESS GAUGE, 1/8"BOT
4	1	711019	1/4"MNPT AIR REGULATOR
5	1	711021	1 1/4-18 NUT,AIR REGULATOR MT
6	2	711043	1/4MNPT-3/8 NYL TUBE SNGL LBO
7	2	900064	5/16UNC X 3/4 HEX BOLT
8	2	914002	5/16UNC HEX STOVER NUT
9	1	701184	FOAMER AIR REG MT BOX, STS12
10	1	701183	FOAMER AIR REG MT BOX MT,STS12
11	1	601481	HOSE, 3/8 X 68 AIR
12	1	601482	HOSE, 3/8 X 80 AIR

FRESH WATER TANK ASSEMBLY

DET.	QTY	PART NO.	DESCRIPTION
1	1	470318	RINSE TANK, 3 GAL SQ SAFETY
2	1	500019	3/4NPT-1/2HOSE BARB, POLY
3	1	500047	1/2NPT-90-1/2 HOSE BARB, POLY
4	2	520070	HOSE CLAMP NO 8 STAINLESS
5	1	601489	HOSE, 1/2 X 72 CLEAR VINYL
6	1	696082	BALL VALVE 1/2FNPT POLY
7	1	713340	1/2NPT-1/2 HOSE BARB, POLY
8	4	900064	5/16UNC X 3/4 HEX BOLT
9	5	900129	3/8UNC X 1" HEX BOLT
10	5	914004	3/8UNC HEX STOVER NUT
11	4	920501	5/16 LOCK WASHER
12	1	701174	FRESH WATER TANK MT WLD
13	1	701180	FRESH WATER TANK BRACE WLD
14	1	470337	6" LID FOR 3 GAL TANK 470318

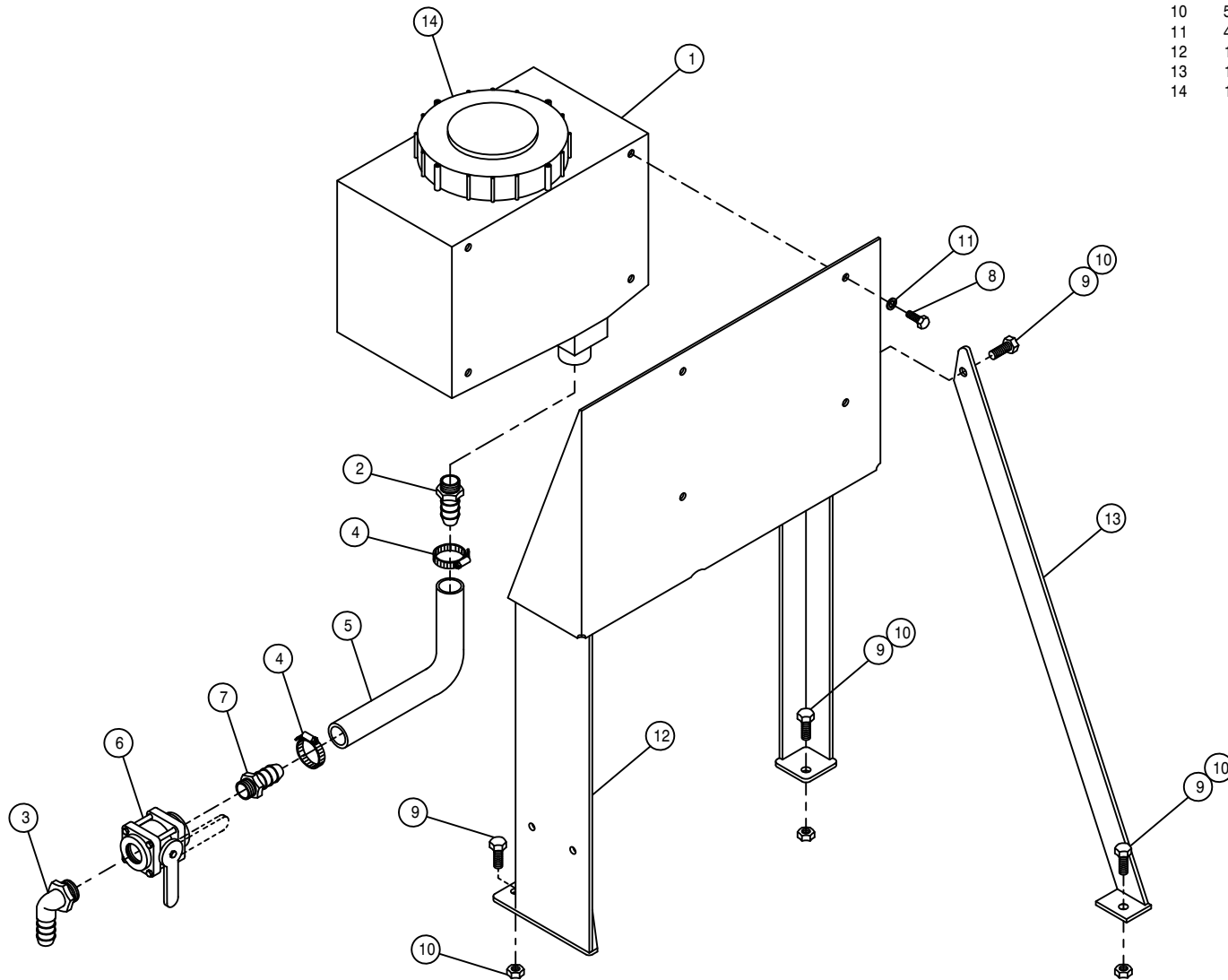

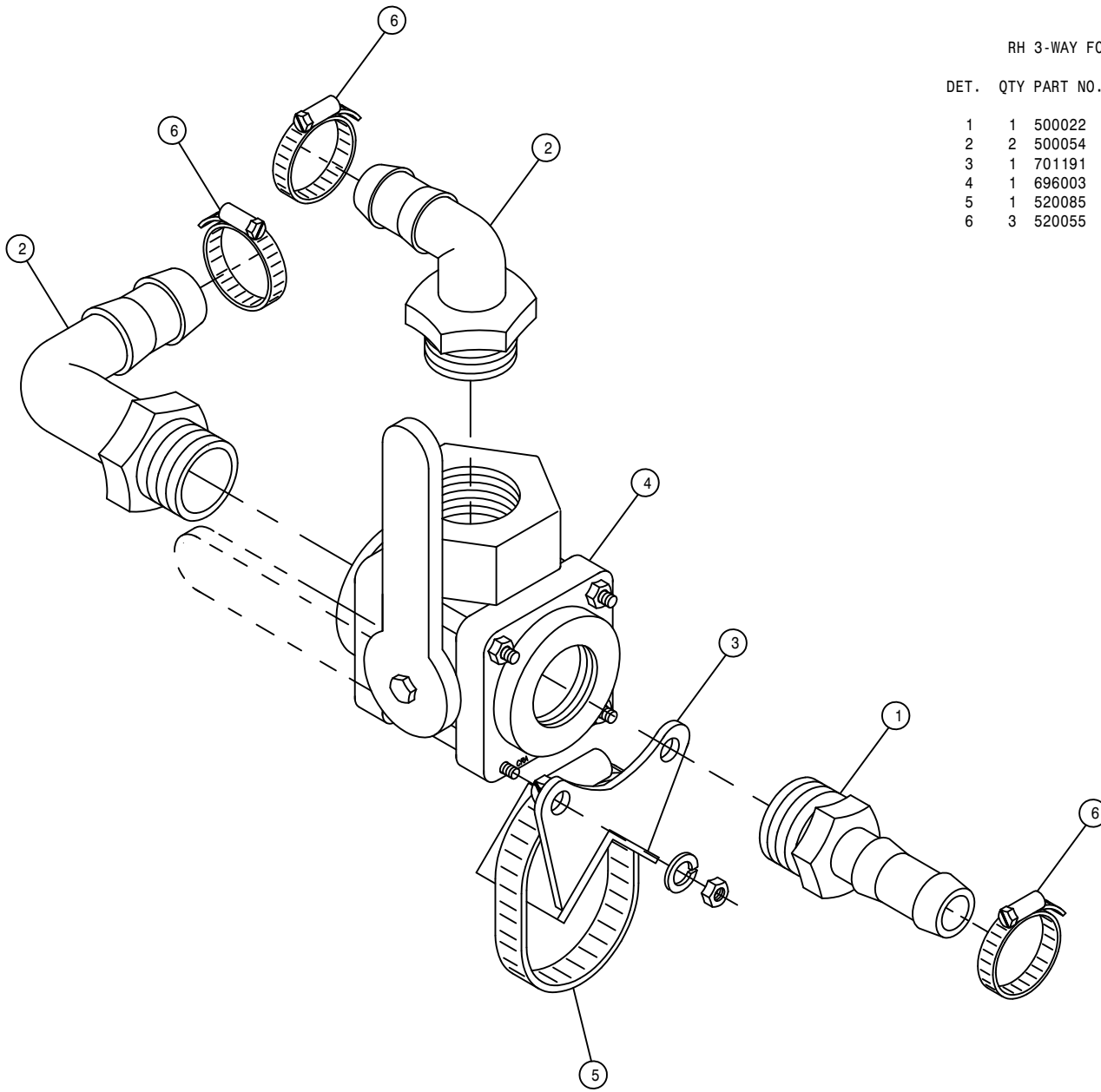

RH 3-WAY FOAMER VALVE ASSEMBLY

DET. QTY PART NO. DESCRIPTION

1	1	500022	3/4NPT-3/4HOSE BARB, POLY
2	2	500054	3/4NPT-90-3/4 HOSE BARB, POLY
3	1	701191	1" SOLU VLV MT WLD
4	1	696003	BALL VLV,3/4NPT 3WAY-SIDE POLY
5	1	520085	HOSE CLAMP NO 24 STAINLESS
6	3	520055	HOSE CLAMP NO 12 STAINLESS

LH 3-WAY FOAMER VALVE ASSEMBLY

DET. QTY PART NO. DESCRIPTION

1	1	500022	3/4NPT-3/4HOSE BARB, POLY
2	2	500054	3/4NPT-90-3/4 HOSE BARB, POLY
3	1	701191	1" SOLU VLV MT WLD
4	1	696003	BALL VLV,3/4NPT 3WAY-SIDE POLY
5	1	520085	HOSE CLAMP NO 24 STAINLESS
6	3	520055	HOSE CLAMP NO 12 STAINLESS

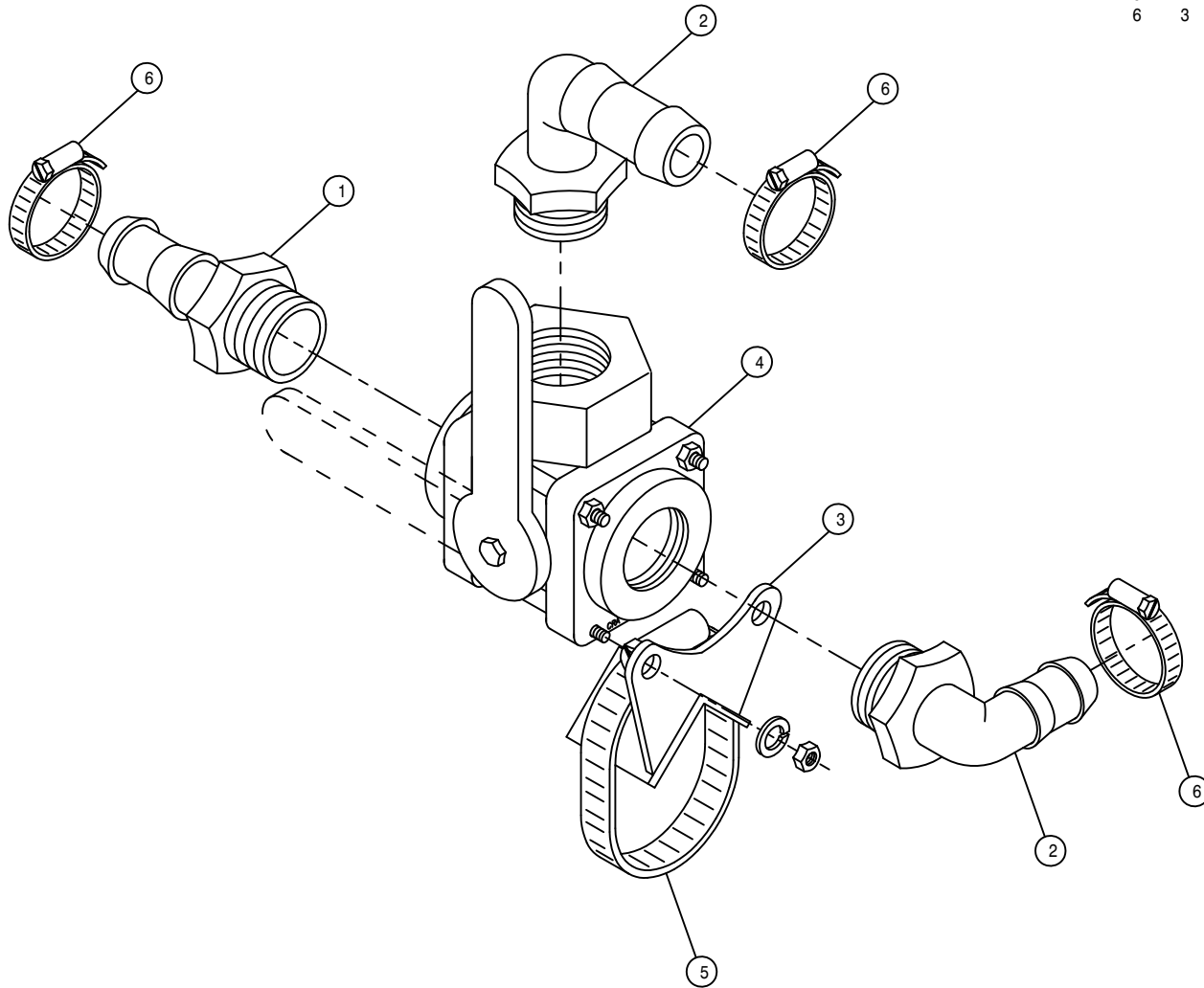

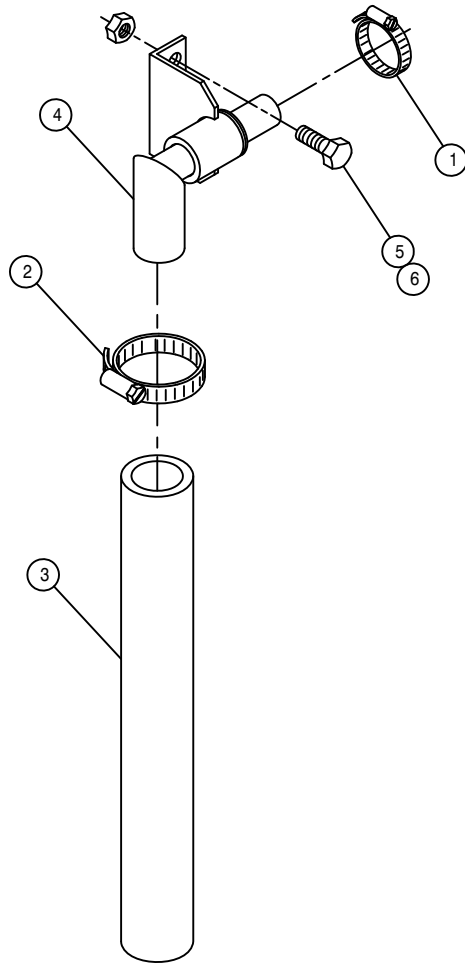

FOAMER DROP HOSE ASSEMBLY

DET. QTY PART NO. DESCRIPTION

1	1	520055	HOSE CLAMP NO 12 STAINLESS
2	1	520085	HOSE CLAMP NO 24 STAINLESS
3	1	601367	HOSE, 1 1/4 X 24 2BR BLK EPDM
4	1	701194	FOAMER DROP HOSE SWIVEL WLD
5	2	900129	3/8UNC X 1" HEX BOLT
6	2	914004	3/8UNC HEX STOVER NUT

BOOM INDICATOR LIGHT ASSEMBLY

DET.	QTY	PART NO.	DESCRIPTION
1	1	164503	BOOM INDICATOR LIGHT MT
2	7	293516	2-WIRE PIGTAIL ASSY
3	7	291713	MTG BRKT FOR 291710/291711
4	2	291711	YELLOW LAMP, 3 3/8" OVAL 12.8V
5	5	291710	RED LAMP, 3 3/8" OVAL 12.8V
6	14	903889	10-32 X 3/4 SLT RDHD MACH SCR
7	14	470175	10-32 HEX FLANGE LOCK NUT
8	2	470118	1/4UNC X 3/4 FLANGE HEX BOLT
9	2	470121	1/4UNC HEX FLANGE LOCK NUT

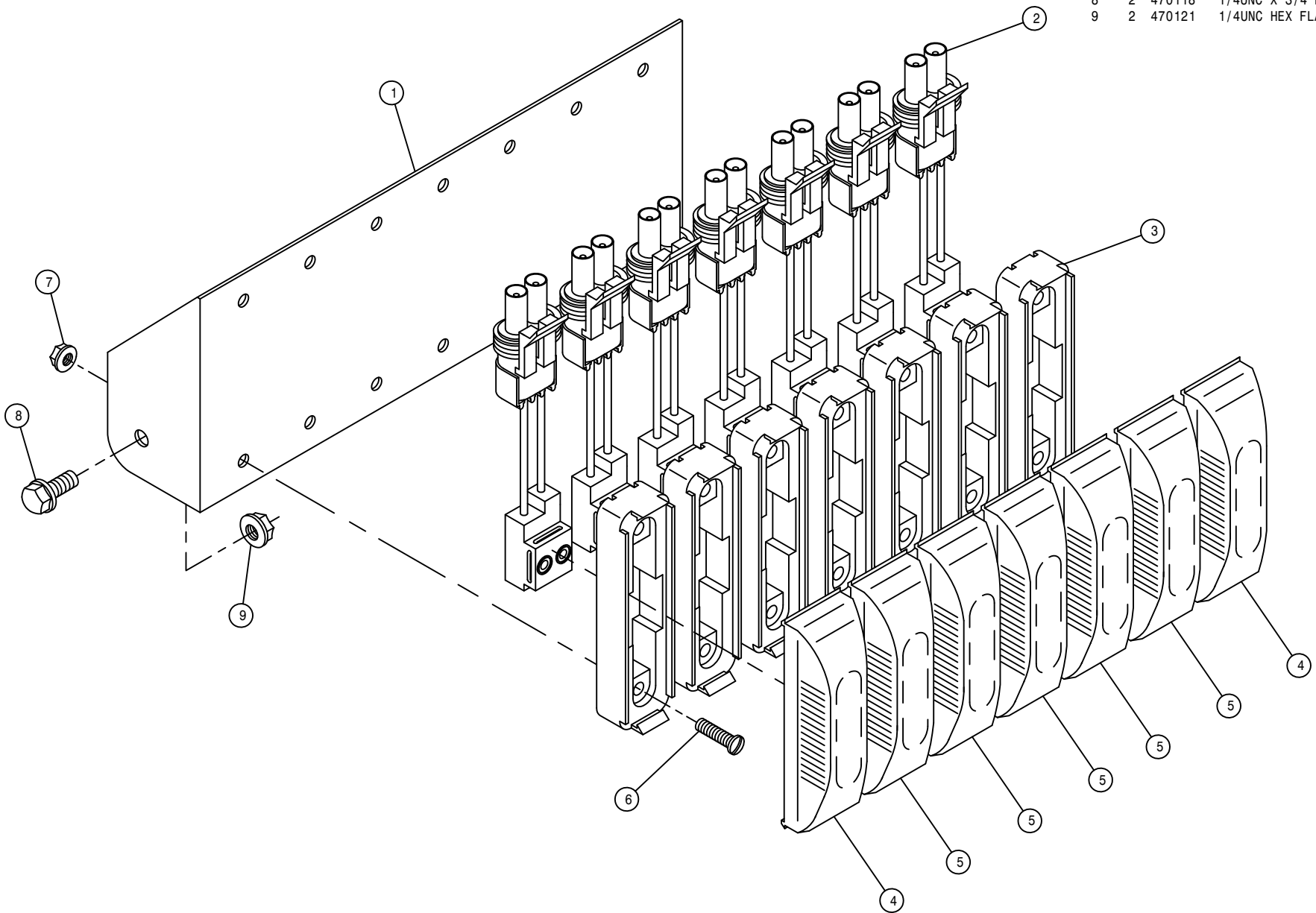

89

250089

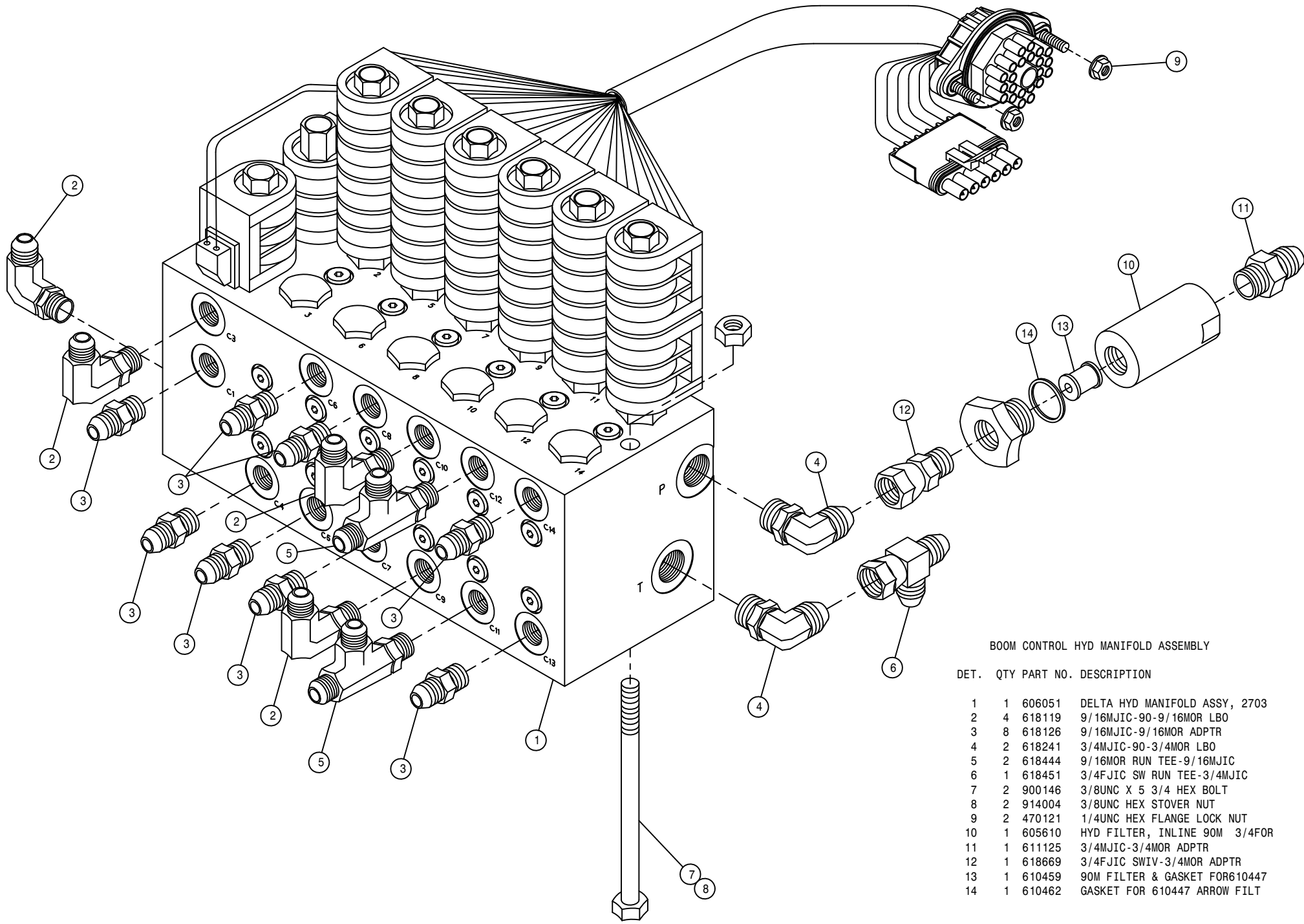

BOOM CONTROL HYD MANIFOLD ASSEMBLY

DET.	QTY	PART NO.	DESCRIPTION
	1	606051	DELTA HYD MANIFOLD ASSY, 2703
	4	618119	9/16MJIC-90-9/16MOR LBO
	8	618126	9/16MJIC-9/16MOR ADPTR
	2	618241	3/4MJIC-90-3/4MOR LBO
	2	618444	9/16MOR RUN TEE-9/16MJIC
	1	618451	3/4FJIC SW RUN TEE-3/4MJIC
	2	900146	3/8UNC X 5 3/4 HEX BOLT
	2	914004	3/8UNC HEX STOVER NUT
	2	470121	1/4UNC HEX FLANGE LOCK NUT
	1	605610	HYD FILTER, INLINE 90M 3/4FOR
	1	611125	3/4MJIC-3/4MOR ADPTR
	1	618669	3/4FJIC SWIV-3/4MOR ADPTR
	1	610459	90M FILTER & GASKET FOR610447
	1	610462	GASKET FOR 610447 ARROW FILT

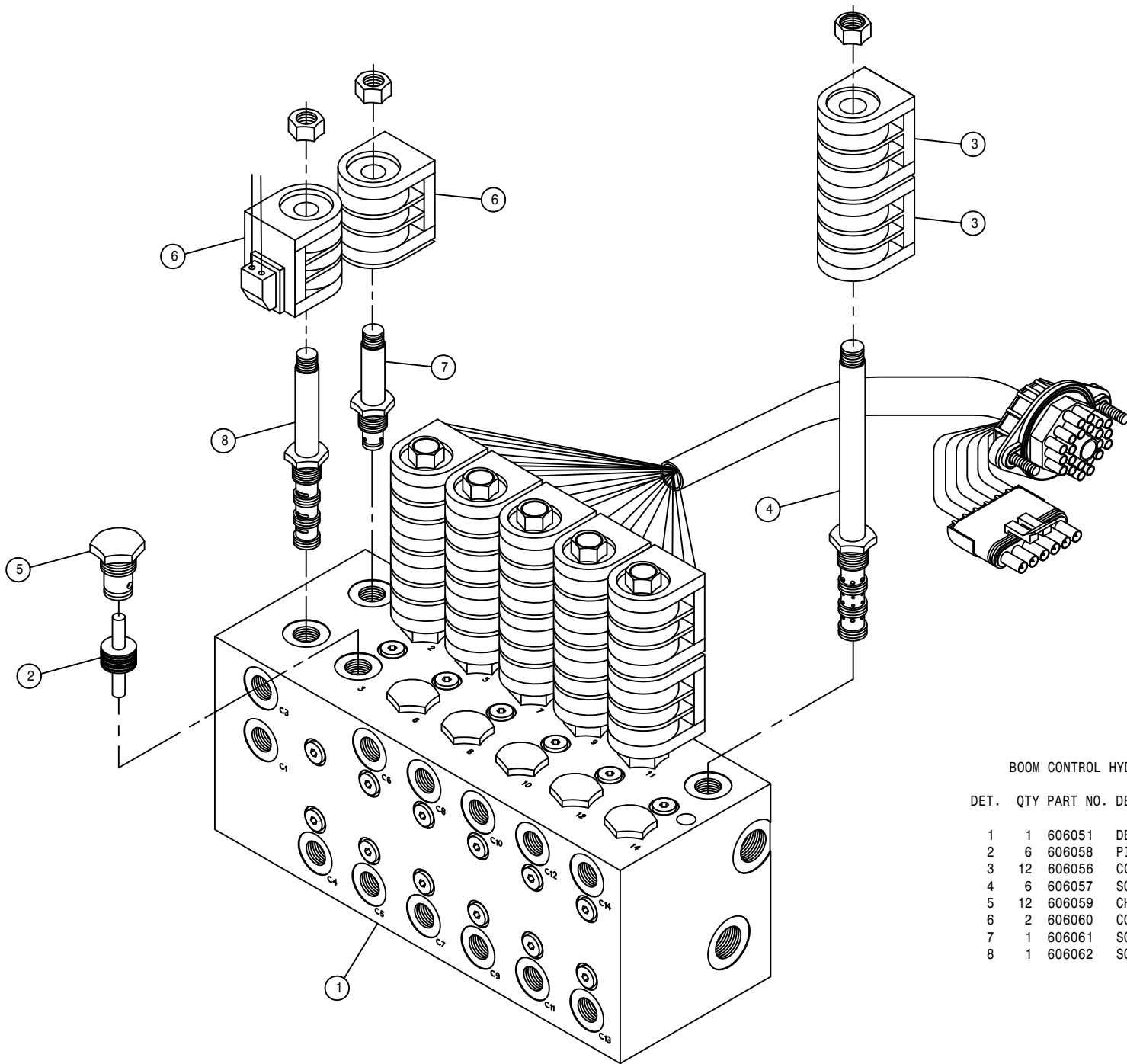

BOOM CONTROL HYD MANIFOLD ASSEMBLY

DET. QTY PART NO. DESCRIPTION

1	1	606051	DELTA HYD MANIFOLD ASSY, 2703
2	6	606058	PISTON ASSY FOR 606050
3	12	606056	COIL(63900502) FOR 606050/051
4	6	606057	SOLE VLV(DGS4M00)FOR 606050/51
5	12	606059	CHECK VALVE FOR 606050
6	2	606060	COIL(80028) FOR 606051
7	1	606061	SOLE VLV(DES2C00) FOR 606051
8	1	606062	SOLE VLV(DGS4B00) FOR 606051

LIFTARM ASSEMBLY

DET. QTY PART NO. DESCRIPTION

DET.	QTY	PART NO.	DESCRIPTION
1	15	470287	TUBE CLAMP, .375-.375 (PAIR)
2	12	900086	5/16UNC X 2 1/4 HEX BOLT
3	1	615761	LIFT RAISE HYD TUBE ASSY
4	1	615762	LIFT LOWER HYD TUBE ASSY
5	1	615764	LEVEL LOWER HYD TUBE ASSY
6	1	615763	LEVEL RAISE HYD TUBE ASSY
7	2	615765	BREAKAWAY HYD TUBE ASSY
8	1	615767	BOOM EXTN LOWER HYD TUBE ASSY
9	1	615766	BOOM EXTN RAISE HYD TUBE ASSY
10	1	615769	RH FOLD LOWER HYD TUBE ASSY
11	1	615768	RH FOLD RAISE HYD TUBE ASSY
12	2	618019	9/16MJIC UNION TEE
13	2	618618	9/16MJIC-90-9/16FJIC SWIV LBO
14	10	619010	9/16MJIC UNION
15	3	900016	1/4UNC X 4 1/2 HEX BOLT
16	16	900403	3/4UNC X 2" HEX BOLT
17	4	910012	3/4UNC HEX NUT
18	3	914000	1/4UNC HEX STOVER NUT
19	12	914012	3/4UNC HEX STOVER NUT
20	4	920506	3/4 LOCK WASHER
21	2	164424	QUICK ATTACH PLT WLD
22	12	164452	LIFT ARM MT PIVOT PIN,STS12 00
23	1	164432	UPPER LIFT ARM WLD
24	8	121107	LIFTARM BEARING, ORKOT
25	4	121109	LIFT CYL BRG, ORKOT
26	2	621060	BOOM LIFT CYL ASSY STS12
27	2	164450	LWR LIFTARM WLD
28	12	914002	5/16UNC HEX STOVER NUT

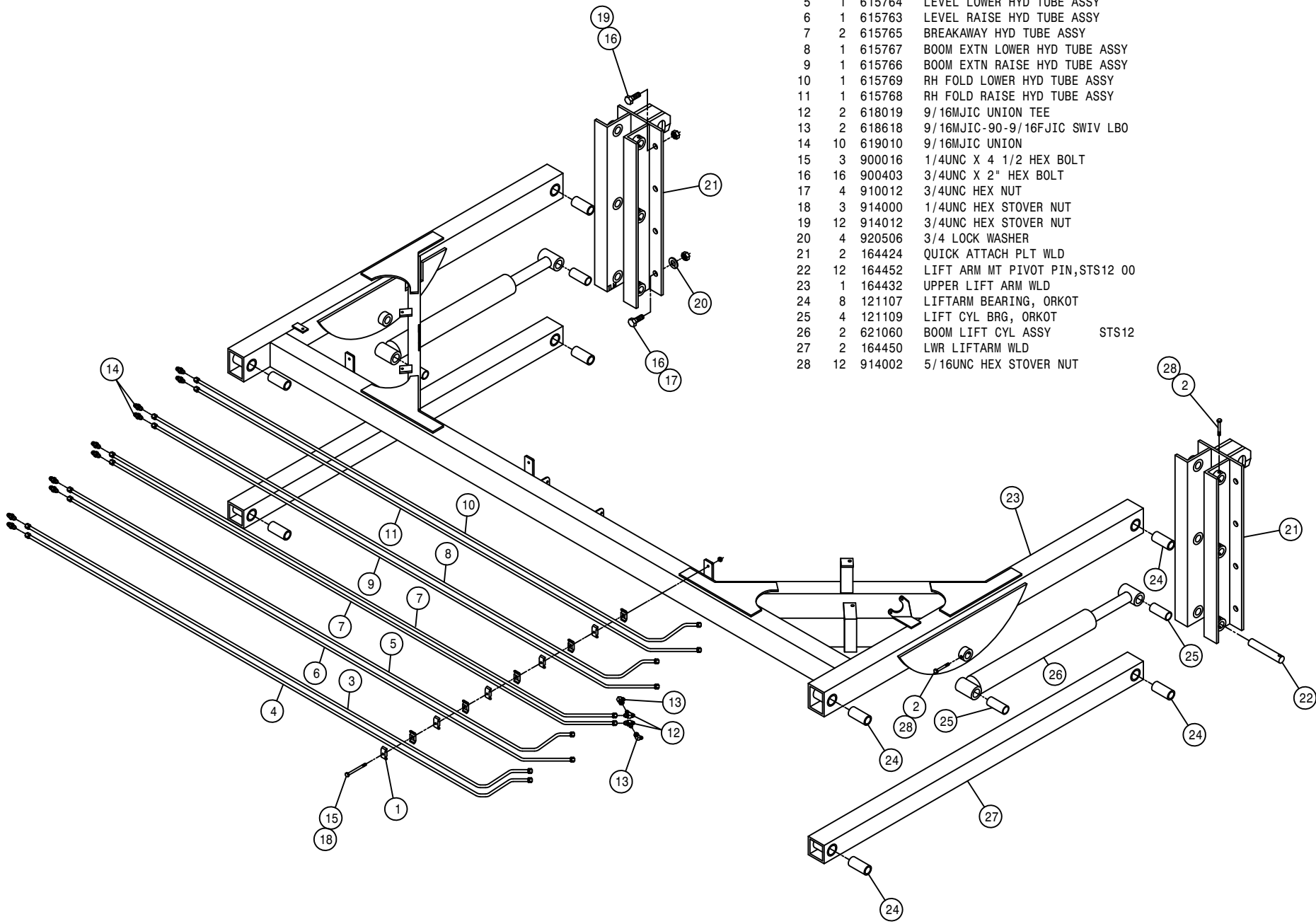

TRANSOM ASSEMBLY

DET. QTY PART NO. DESCRIPTION

DET.	QTY	PART NO.	DESCRIPTION
1	4	470012	COTTER PIN 5/16 X 2" LG,316 SS
2	4	121029	JOURNAL BRG, 1.00 ID X 1.00 LG
3	4	470329	3/8UNC X 1 1/4 FLANGE HEX BOLT
4	16	473842	1/4UNC LOCK NUT,CNTR POINT SS
5	8	473979	.25UNC-1.12ID-1.50U-BOLT SQ SS
6	2	900284	1/2UNC X 4 3/4 HEX BOLT
7	2	914008	1/2UNC HEX STOVER NUT
8	1	164661	TRANSOM WLD STS12 2001
9	1	164469	RH TRANSOM PIVOT TUBE WLD
10	2	164481	INNER TRANSOM PIVOT TUBE
11	2	121103	TRANSOM PIVOT BRG, LWR ORKOT
12	1	164470	LH TRANSOM PIVOT TUBE WLD
13	4	121104	BOOM PIVOT BEARING, ORKOT
14	2	164482	TRANSOM PIVOT WASHER
15	6	164483	FOLD CYL STOP SPACER, 16 GA
16	2	164484	FOLD CYL STOP SPACER, .500
17	1	164485	HOSE SUPPORT WLD
18	2	164664	FOLD CYL TRUNION MT WLD 2001
19	2	164491	NOZL MT TUBE, TRANSOM STS12
20	2	121101	TRANSOM PIVOT BRG,TOP ORKOT
21	2	470326	ACCUMULATOR, DIAPHRAGM
22	2	618673	3/4MOR BRANCH TEE-9/16MJIC
23	8	914004	3/8UNC HEX STOVER NUT
24	2	164493	ACCUMULATOR MT WLD
25	2	164498	BOOM FOLD CYL PIN WLD
26	2	164496	LEVEL CYL PIN WLD, TRANSOM END
27	4	920008	1" SAE FLAT WASHER
28	2	621061	BOOM LEVEL CYL ASSY 3.00"STS12
29	2	621055	BOOM FOLD CYL ASSY STS12
30	8	900333	5/8UNC X 1 1/2 HEX BOLT
31	2	900129	3/8UNC X 1" HEX BOLT
32	2	900130	3/8UNC X 1 1/4 HEX BOLT
33	4	629727	FINISH PLUG FOR 1 IN X 16 GA
34	2	164641	BOOM PIVOT BRG SPACER STS12
35	2	164642	TRANSOM PIVOT BRG SPACER STS12
36	8	914010	5/8UNC HEX STOVER NUT

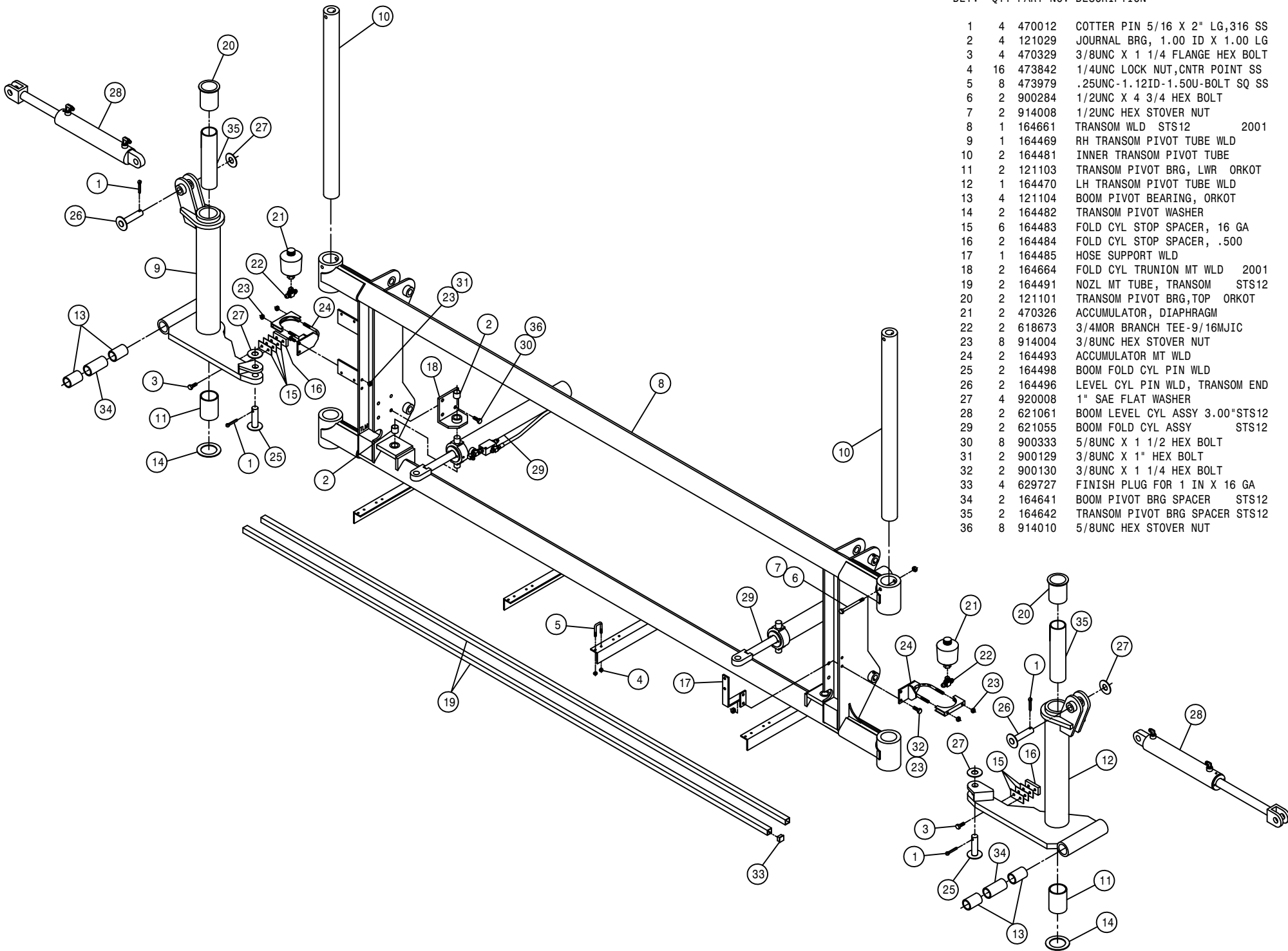

93

250093

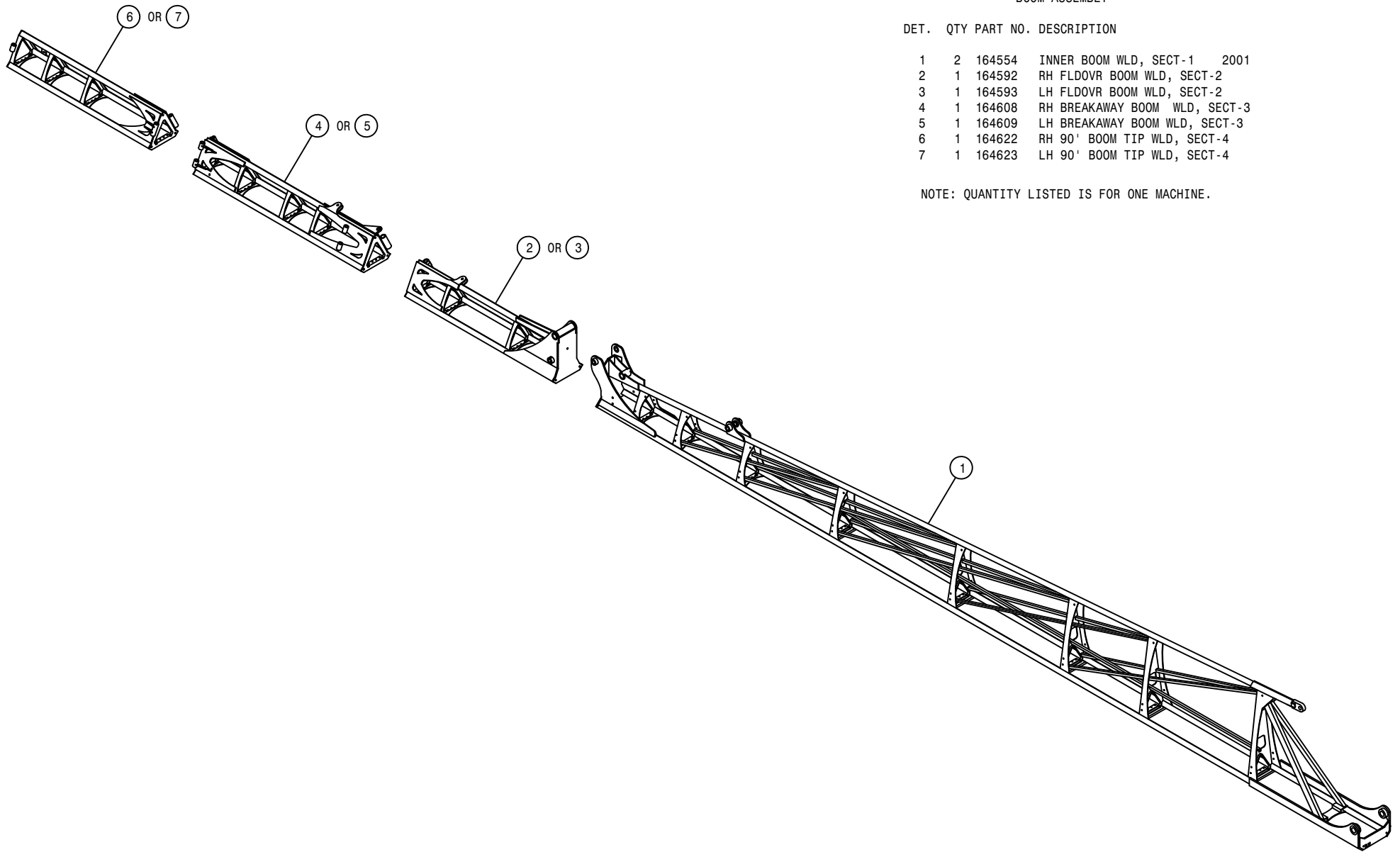

BOOM ASSEMBLY

DET.	QTY	PART NO.	DESCRIPTION
1	2	164554	INNER BOOM WLD, SECT-1 2001
2	1	164592	RH FLDOVR BOOM WLD, SECT-2
3	1	164593	LH FLDOVR BOOM WLD, SECT-2
4	1	164608	RH BREAKAWAY BOOM WLD, SECT-3
5	1	164609	LH BREAKAWAY BOOM WLD, SECT-3
6	1	164622	RH 90' BOOM TIP WLD, SECT-4
7	1	164623	LH 90' BOOM TIP WLD, SECT-4

NOTE: QUANTITY LISTED IS FOR ONE MACHINE.

INNER BOOM ASSEMBLY

DET. QTY PART NO. DESCRIPTION

1	2	164554	INNER BOOM WLD, SECT-1	2001
2	28	470287	TUBE CLAMP, .375-.375	(PAIR)
3	36	473842	1/4UNC LOCK NUT,CNTR POINT SS	
4	18	473979	.25UNC-1.12ID-1.50U-BOLT SQ SS	
5	8	615760	BOOM HYD TUBE ASSY	
6	16	619010	9/16MJIC UNION	
7	4	629727	FINISH PLUG FOR 1 IN X 16 GA	
8	12	900007	1/4UNC X 2" HEX BOLT	
9	14	914000	1/4UNC HEX STOVER NUT	
10	2	164515	BOOM HINGE PIN WLD	
11	2	164547	NOZL MT TUBE, BOOM SECT-1 (A)	
12	2	164548	NOZL MT TUBE WLD, SECT-1 (B)	
13	2	164500	LEVEL CYL PIN WLD, SHAFT END	
14	2	900073	5/16UNC X 3 1/4 HEX BOLT	
15	2	470012	COTTER PIN 5/16 X 2" LG,316 SS	
16	2	914002	5/16UNC HEX STOVER NUT	
17	2	900027	1/4UNC X 5" HEX BOLT	
18	2	920008	1" SAE FLAT WASHER	

NOTE: QUANTITY LISTED IS FOR ONE MACHINE.

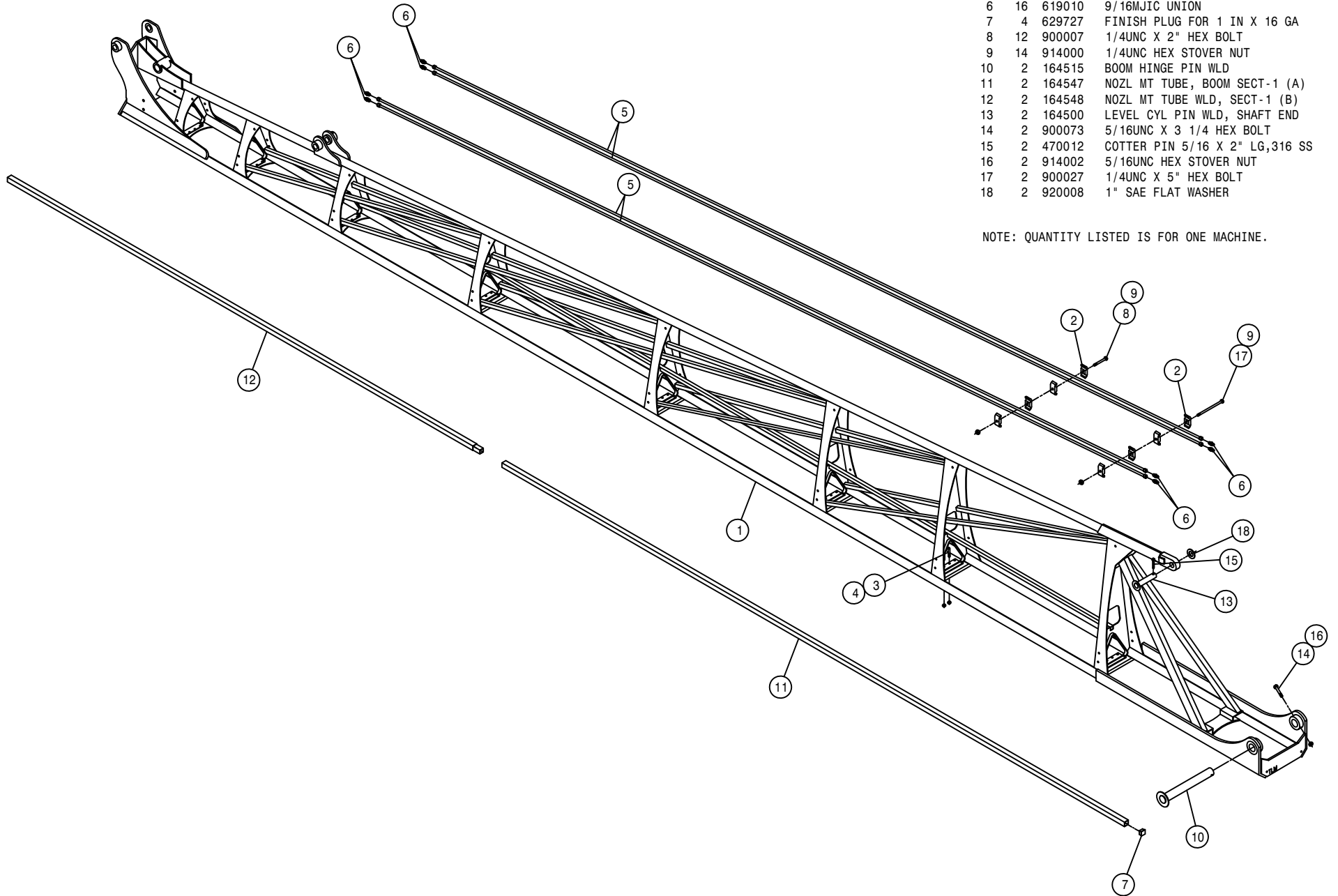

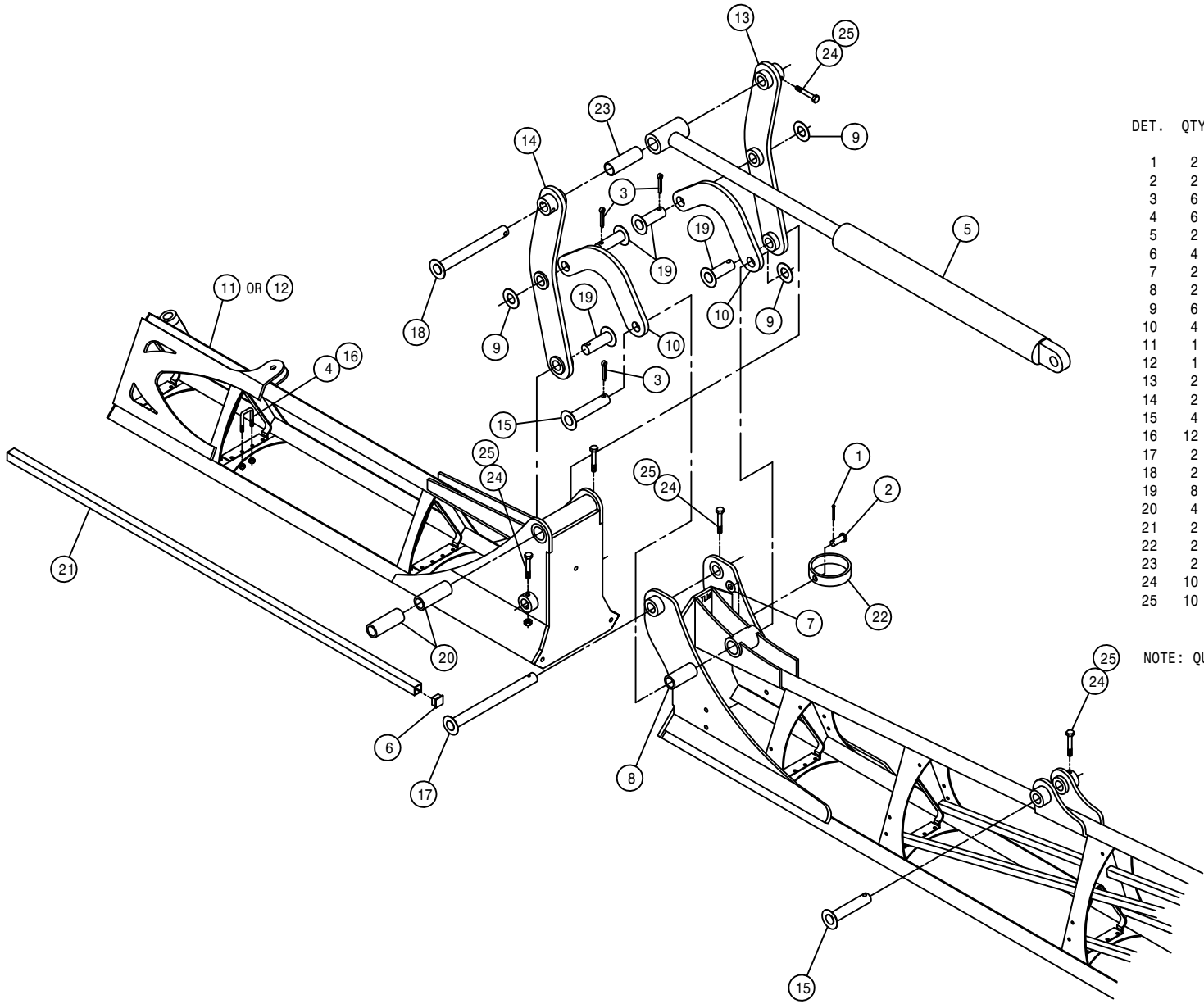

80'-90' BOOM HINGE ASSEMBLY

DET.	QTY	PART NO.	DESCRIPTION
1	2	390984	COTTER PIN 1/8 X 1 1/4
2	2	472277	CLEVIS PIN, .50 X 1.25LG PLT
3	6	470012	COTTER PIN 5/16 X 2" LG,316 SS
4	6	473979	.25UNC-1.12ID-1.50U-BOLT SQ SS
5	2	621056	OUTR BOOM FOLD CYL ASSY STS12
6	4	629727	FINISH PLUG FOR 1 IN X 16 GA
7	2	920004	1/2 SAE FLAT WASHER
8	2	121107	LIFTARM BEARING, ORKOT
9	6	920008	1" SAE FLAT WASHER
10	4	164643	XK402 TOP ARM(LEFT) 10.35 CNTR
11	1	164592	RH FLDOVR BOOM WLD, SECT-2
12	1	164593	LH FLDOVR BOOM WLD, SECT-2
13	2	164528	RH FOLD-OVER BOOMERANG WLD
14	2	164529	LH FOLD-OVER BOOMERANG WLD
15	4	164522	BOOM FOLD CYL PIN WLD
16	12	473842	1/4UNC LOCK NUT,CNTR POINT SS
17	2	164518	BOOM FOLD PIVOT PIN WLD
18	2	164520	BOOM CYL PIVOT PIN WLD
19	8	164524	BOOMERANG CNTR PIVOT PIN WLD
20	4	121106	BOOM FOLD BRG, ORKOT
21	2	164551	NOZL MT TUBE, BOOM SECT-2
22	2	164517	HOSE SUPPORT RING
23	2	121108	OUTR BOOM FOLD CYL BRG, ORKOT
24	10	900086	5/16UNC X 2 1/4 HEX BOLT
25	10	914002	5/16UNC HEX STOVER NUT

NOTE: QUANTITY LISTED IS FOR ONE MACHINE.

BOOM BREAKAWAY ASSEMBLY

DET. QTY PART NO. DESCRIPTION

DET.	QTY	PART NO.	DESCRIPTION
1	36	473842	1/4UNC LOCK NUT,CNTR POINT SS
2	18	473979	.25UNC-1.12ID-1.50U-BOLT SQ SS
3	6	470011	COTTER PIN 5/32 X 1 1/2,316 SS
4	2	621057	BOOM BREAKAWAY CYL ASSY STS12
5	8	629727	FINISH PLUG FOR 1 IN X 16 GA
6	1	164592	RH FLDOVR BOOM WLD, SECT-2
7	1	164593	LH FLDOVR BOOM WLD, SECT-2
8	1	164608	RH BREAKAWAY BOOM WLD, SECT-3
9	1	164609	LH BREAKAWAY BOOM WLD, SECT-3
10	1	164622	RH 90' BOOM TIP WLD, SECT-4
11	1	164623	LH 90' BOOM TIP WLD, SECT-4
12	4	164637	BOOM TIP SECTION PIN WLD
13	8	121110	BREAKAWAY BRG, ORKOT
14	2	164553	NOZL MT TUBE, BOOM SECT-4
15	2	164552	NOZL MT TUBE, BOOM SECT-3
16	2	900265	1/2UNC X 1 1/2 HEX BOLT
17	2	900267	1/2UNC X 2" HEX BOLT
18	4	914008	1/2UNC HEX STOVER NUT
19	2	164526	BOOM BREAKAWAY PIVOT PIN WLD

NOTE: QUANTITY LISTED IS FOR ONE MACHINE.

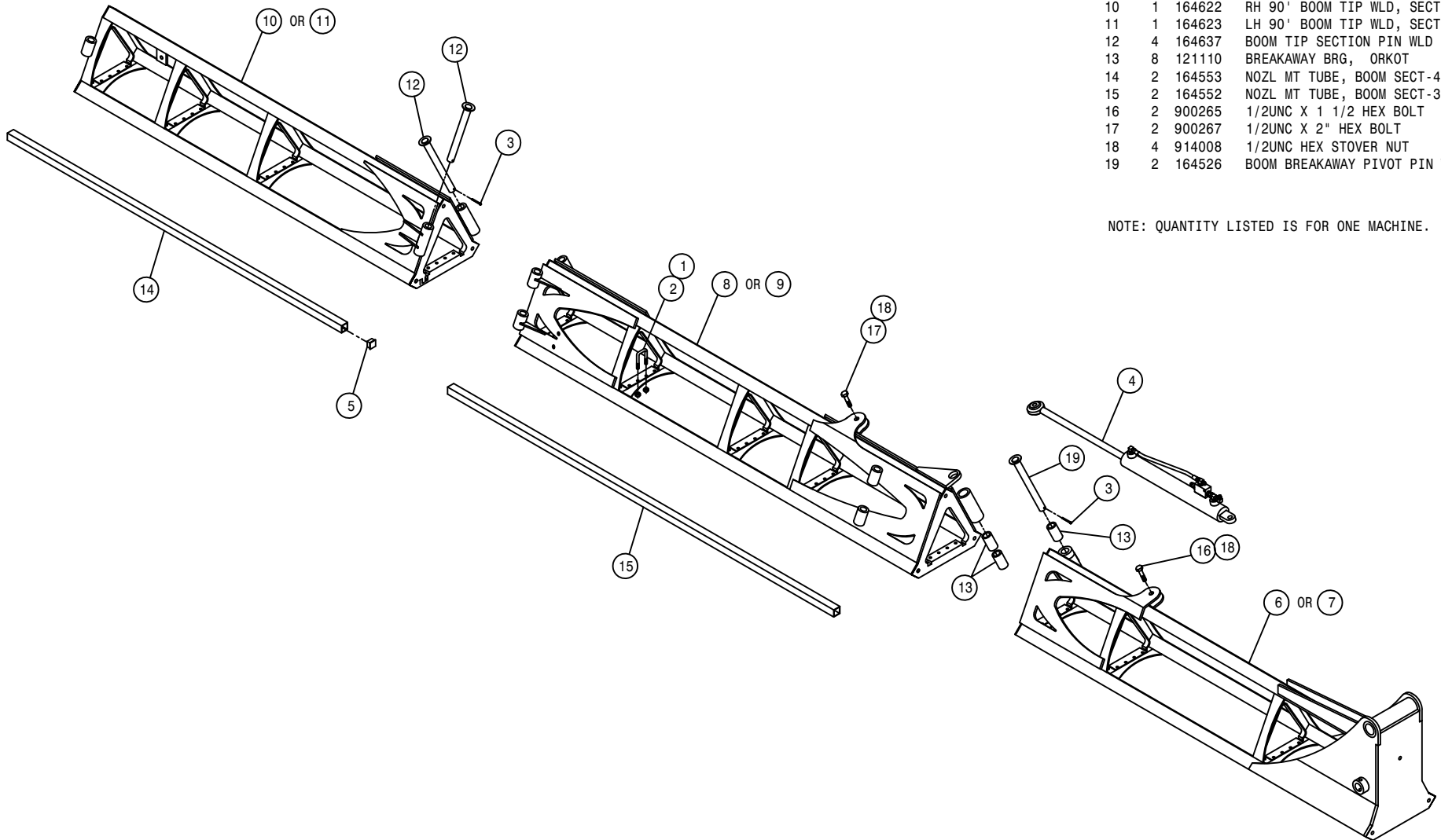

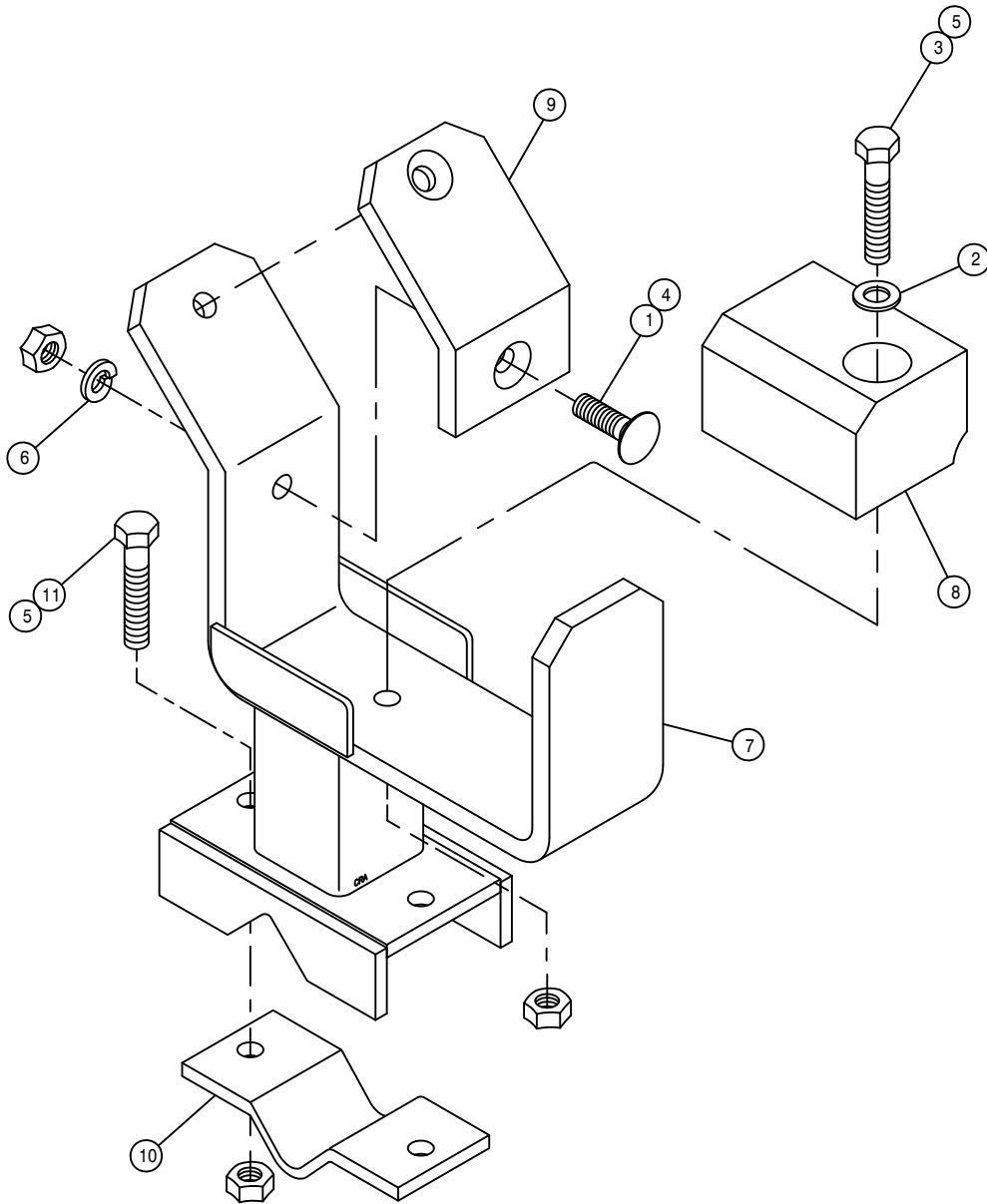

BOOM SUPPORT CRADLE ASSEMBLY, 80' -90'

DET.	QTY	PART NO.	DESCRIPTION
1	2	470328	3/8UNC X 1 1/4 #3HD PLOW BOLT
2	1	483043	3/8 REGULAR FLAT WASHER
3	1	900133	3/8UNC X 2" HEX BOLT
4	2	910004	3/8UNC HEX NUT
5	3	914004	3/8UNC HEX STOVER NUT
6	2	920502	3/8 LOCK WASHER
7	1	164535	BOOM SUPPORT CRADLE WLD,80/90'
8	1	164541	BOOM SUPPORT PAD
9	1	164542	BOOM SUPPORT CRADLE PAD
10	1	164543	BOOM SUPPORT KEEPER
11	2	900170	3/8UNC X 2 1/4 HEX BOLT

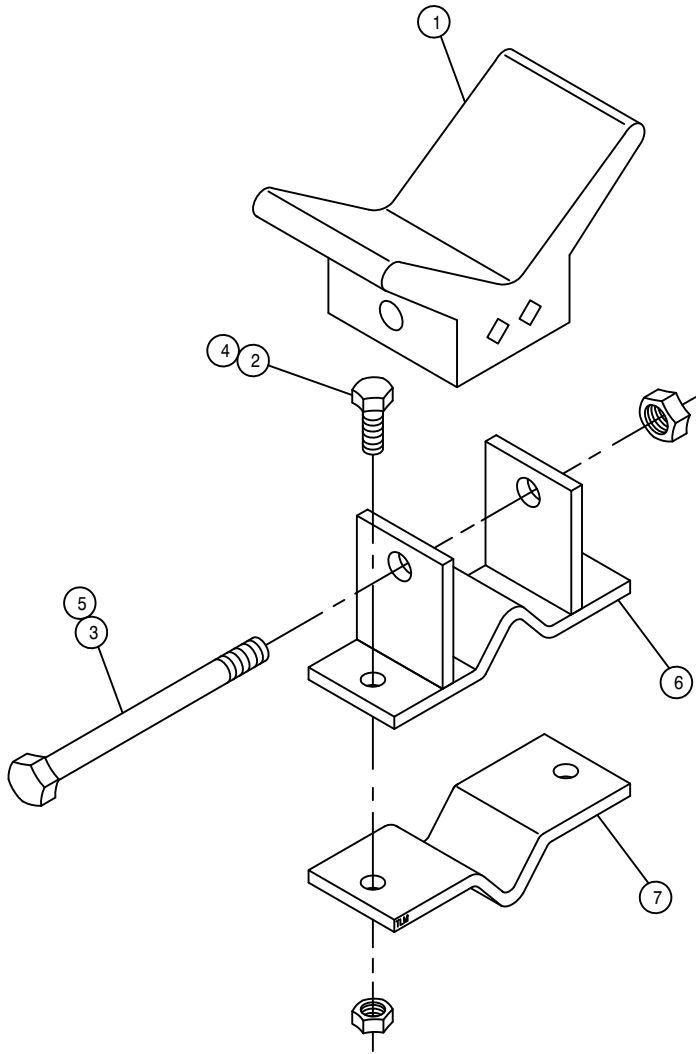

90' BOOM SUPPORT ASSEMBLY

DET. QTY PART NO. DESCRIPTION

1	1	470324	3" RUBBER BOW GUARD
2	2	900130	3/8UNC X 1 1/4 HEX BOLT
3	1	900273	1/2UNC X 3 3/4 HEX BOLT
4	2	914004	3/8UNC HEX STOVER NUT
5	1	914008	1/2UNC HEX STOVER NUT
6	1	164544	FRT BOOM SUPPORT WLD, 90' BOOM
7	1	164545	FRT BOOM SUPPORT MT

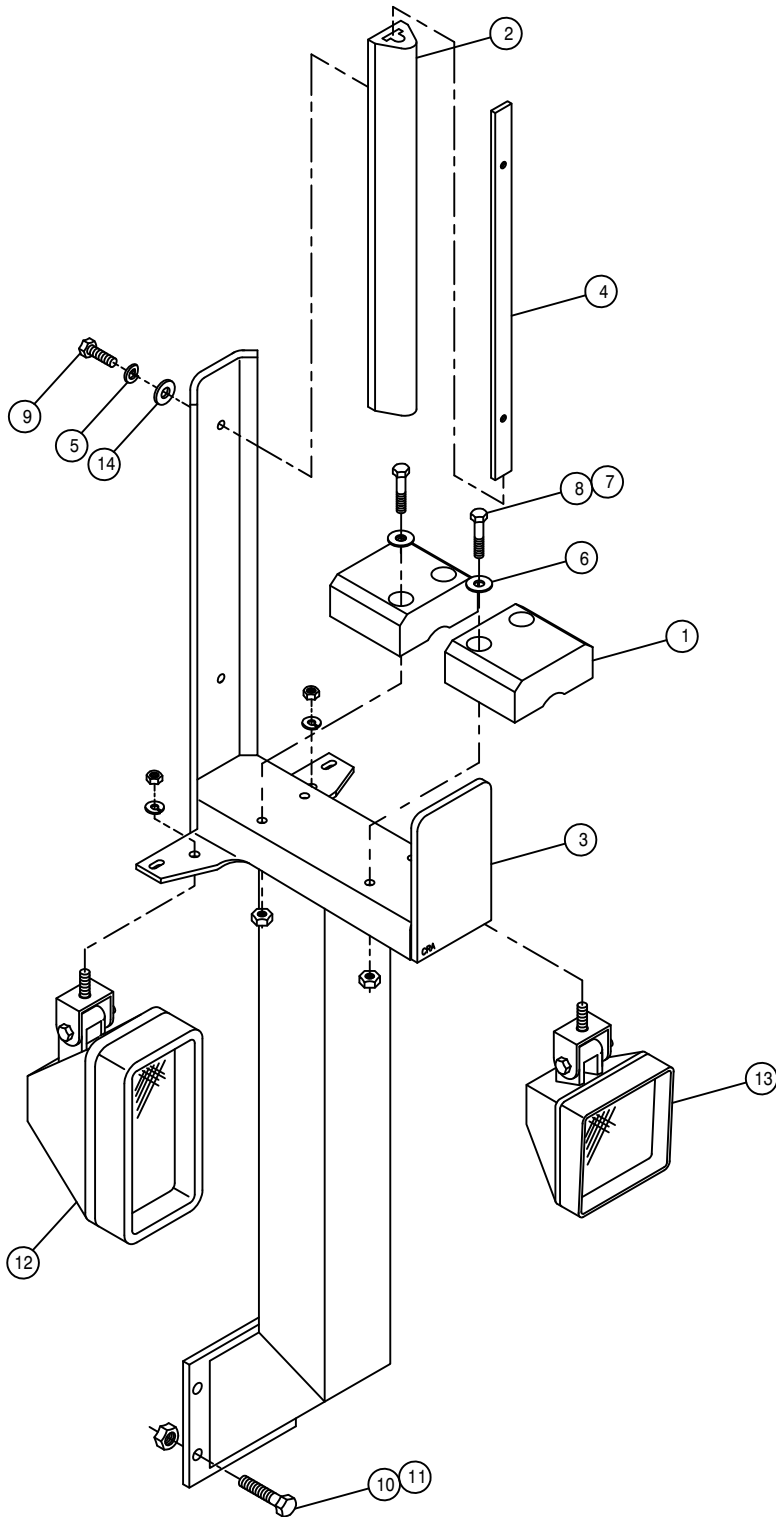

BOOM CRADLE ASSEMBLY

DET.	QTY	PART NO.	DESCRIPTION
	4	164513	BOOM CRADLE PAD
	2	164512	RUBBER BUMPER, BOOM CRADLE
	2	164505	BOOM CRADLE WLD
	2	164514	RUBBER BUMPER KEEPER PLT
	4	920501	5/16 LOCK WASHER
	8	920002	3/8 SAE FLAT WASHER
	8	914004	3/8UNC HEX STOVER NUT
	8	900133	3/8UNC X 2" HEX BOLT
	4	900066	5/16UNC X 1 1/4 HEX BOLT
	8	900265	1/2UNC X 1 1/2 HEX BOLT
	8	914008	1/2UNC HEX STOVER NUT
	2	291779	HALOGEN WORKLAMP, LH MT 12V55W
	2	291780	HALOGEN WORKLAMP, CNTR MT12V55W
	4	920001	5/16 SAE FLAT WASHER

*NOTE: QUANTITY LISTED IS FOR ONE MACHINE.

101

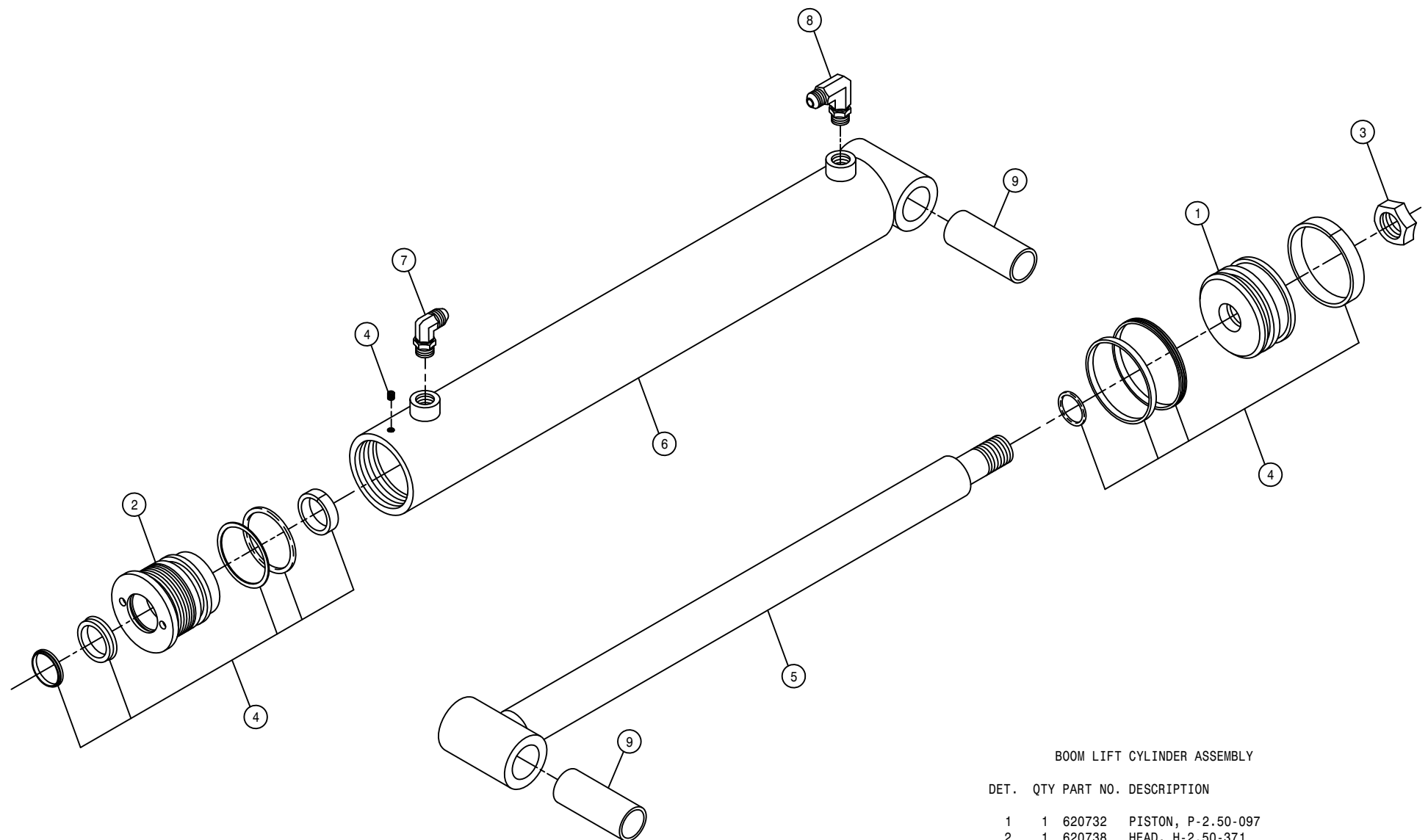

BOOM LIFT CYLINDER ASSEMBLY

DET.	QTY	PART NO.	DESCRIPTION
	1	620732	PISTON, P-2.50-097
	1	620738	HEAD, H-2.50-371
	1	620766	NUT, N-1.00-02
	1	620790	REPAIR KIT, HYD CYL, RK-2.50-806
	1	620928	SHAFT WLD, LIFT CYL 620925
	1	620929	BARREL WLD, LIFT CYL 620925
	1	618119	9/16MJIC-90-9/16MOR LBO
	1	618689	9/16MOR-90-9/16MJ .042 CHK VLV
	2	121109	LIFT CYL BRG, ORKOT

NOTE: 1. 620925 - BOOM LIFTARM CYLINDER ASSEMBLY ITEMS 1-6
 2. 621060 - BOOM LIFTARM CYLINDER ASSEMBLY WITH FITTINGS

250101

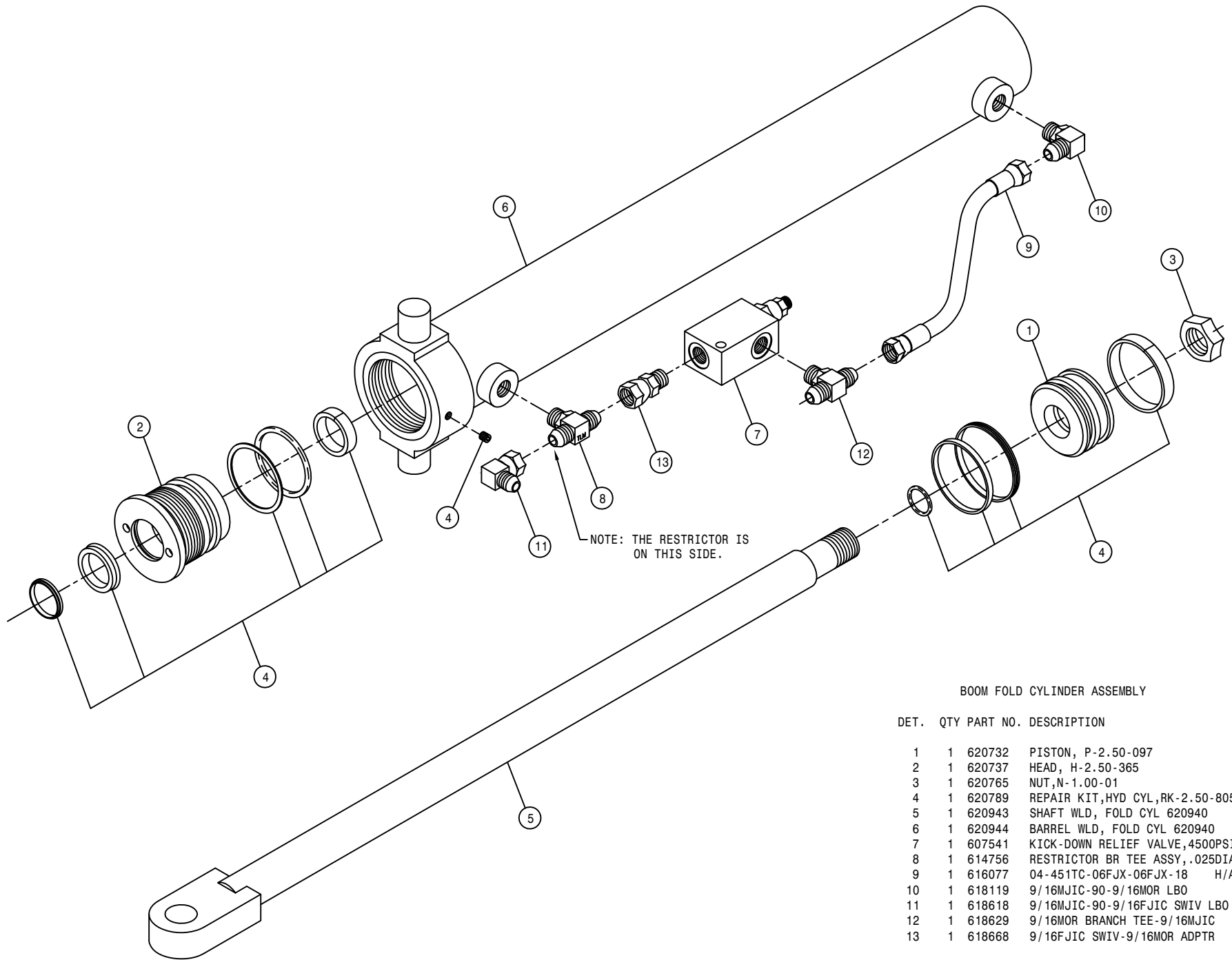

BOOM FOLD CYLINDER ASSEMBLY

DET. QTY PART NO. DESCRIPTION

DET.	QTY	PART NO.	DESCRIPTION
1	1	620732	PISTON, P-2.50-097
2	1	620737	HEAD, H-2.50-365
3	1	620765	NUT, N-1.00-01
4	1	620789	REPAIR KIT, HYD CYL, RK-2.50-805
5	1	620943	SHAFT WLD, FOLD CYL 620940
6	1	620944	BARREL WLD, FOLD CYL 620940
7	1	607541	KICK-DOWN RELIEF VALVE, 4500PSI
8	1	614756	RESTRICTOR BR TEE ASSY, .025DIA
9	1	616077	04-451TC-06FJX-06FJX-18 H/A
10	1	618119	9/16MJIC-90-9/16MOR LBO
11	1	618618	9/16MJIC-90-9/16FJIC SWIV LBO
12	1	618629	9/16MOR BRANCH TEE-9/16MJIC
13	1	618668	9/16FJIC SWIV-9/16MOR ADPTR

NOTE: 1. 620940 - BOOM FOLD CYLINDER ASSEMBLY ITEMS 1-6
 2. 621055 - BOOM FOLD CYLINDER ASSEMBLY WITH FITTINGS

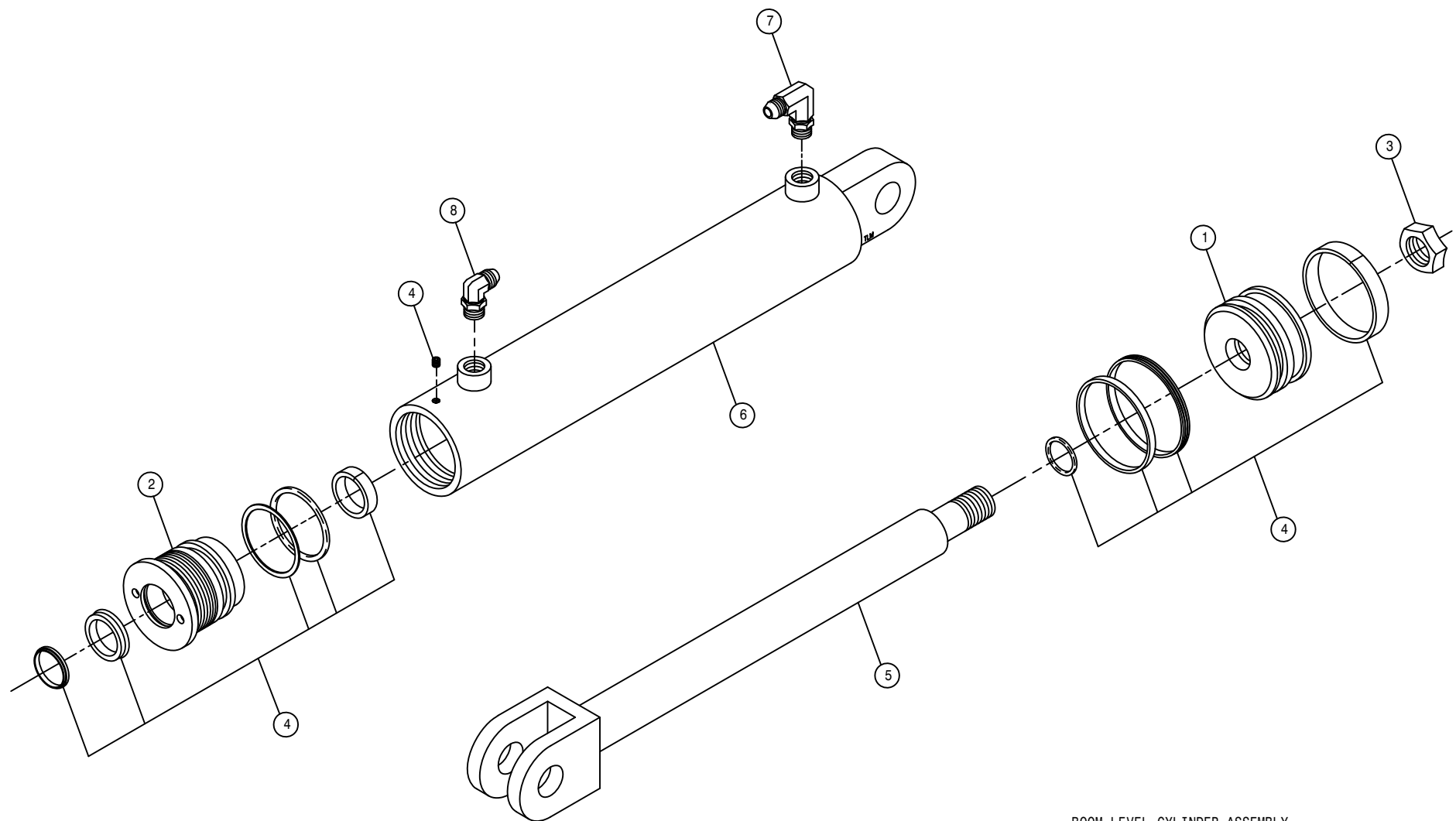

BOOM LEVEL CYLINDER ASSEMBLY

DET.	QTY	PART NO.	DESCRIPTION
	1	620734	PISTON, P-3.00-097
	1	620740	HEAD, H-3.00-325
	1	620765	NUT,N-1.00-01
	1	620792	REPAIR KIT,HYD CYL,RK-3.00-801
	1	620953	SHAFT WLD, LEV CYL 620950
	1	620954	BARREL WLD, LEV CYL 620950
	1	618119	9/16MJIC-90-9/16MOR LBO
	1	618689	9/16MOR-90-9/16MJ .042 CHK VLV

NOTE: 1. 620950 - BOOM LEVEL CYLINDER ASSEMBLY ITEMS 1-6
 2. 621061 - BOOM LEVEL CYLINDER ASSEMBLY WITH FITTINGS

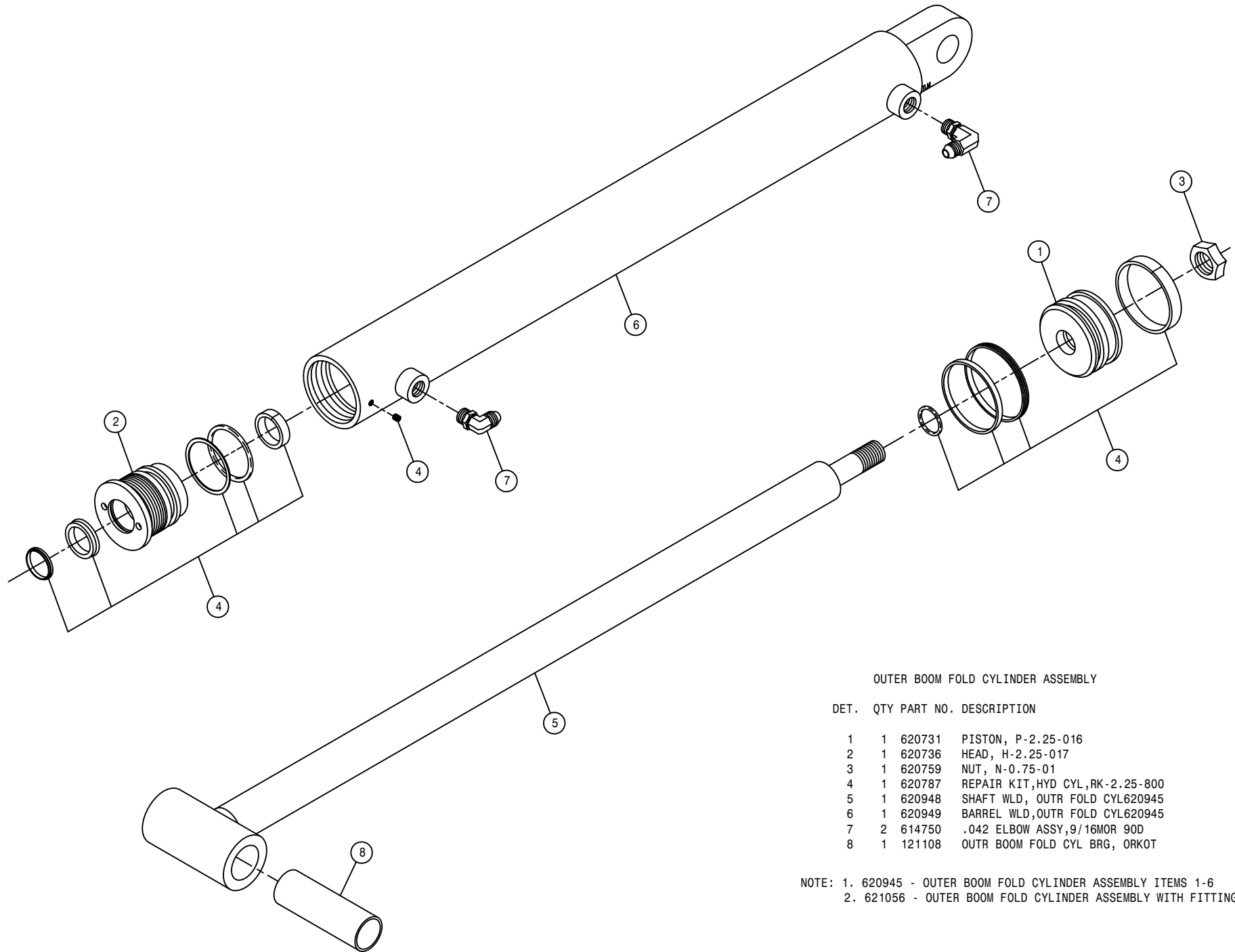

OUTER BOOM FOLD CYLINDER ASSEMBLY

DET.	QTY	PART NO.	DESCRIPTION
	1	620731	PISTON, P-2.25-016
	1	620736	HEAD, H-2.25-017
	1	620759	NUT, N-0.75-01
	1	620787	REPAIR KIT, HYD CYL, RK-2.25-800
	1	620948	SHAFT WLD, OUTR FOLD CYL 620945
	1	620949	BARREL WLD, OUTR FOLD CYL 620945
	2	614750	.042 ELBOW ASSY, 9/16 MOR 90D
	1	121108	OUTR BOOM FOLD CYL BRG, ORKOT

NOTE: 1. 620945 - OUTER BOOM FOLD CYLINDER ASSEMBLY ITEMS 1-6
 2. 621056 - OUTER BOOM FOLD CYLINDER ASSEMBLY WITH FITTINGS

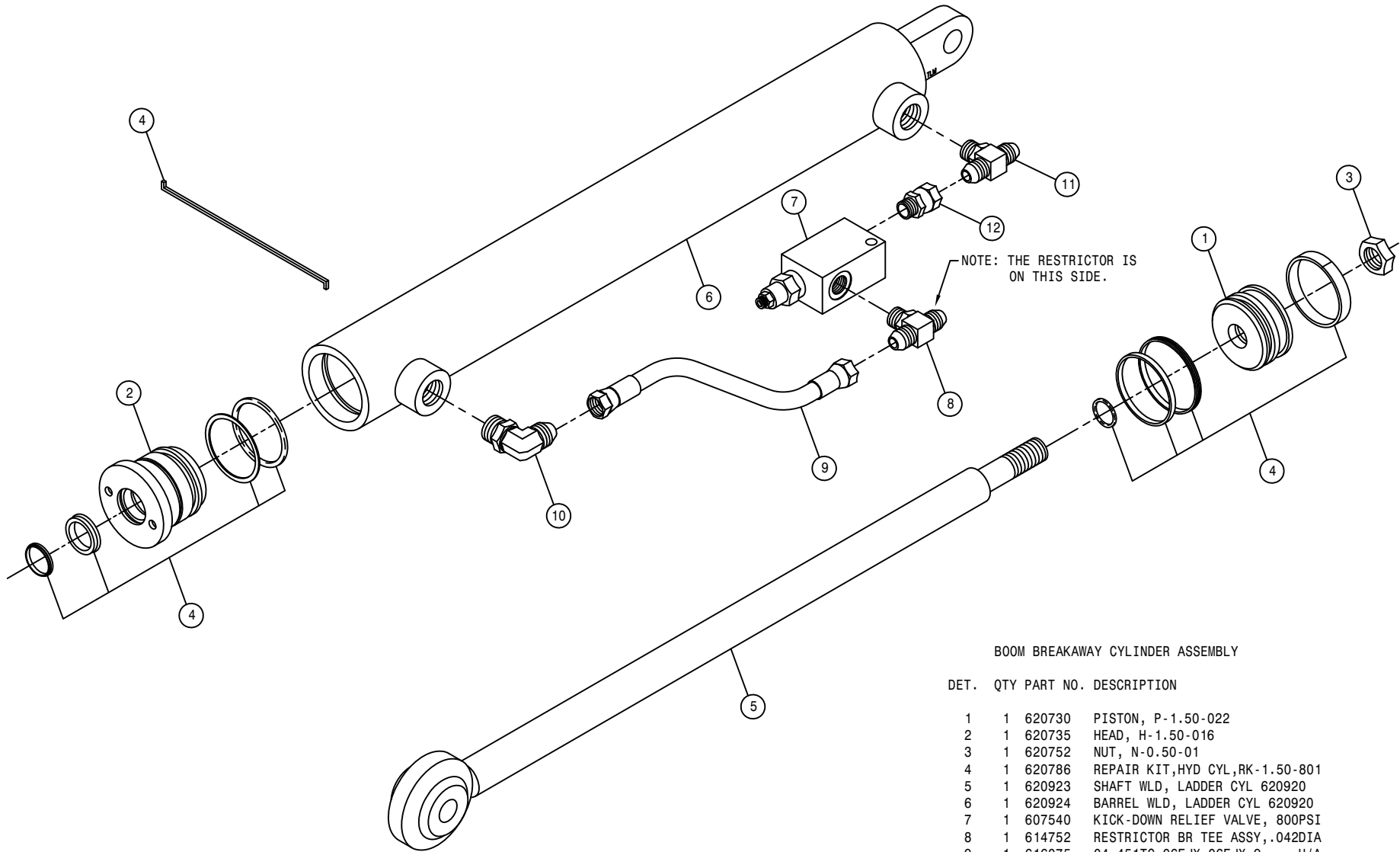

BOOM BREAKAWAY CYLINDER ASSEMBLY

DET.	QTY	PART NO.	DESCRIPTION
	1	620730	PISTON, P-1.50-022
	1	620735	HEAD, H-1.50-016
	1	620752	NUT, N-0.50-01
	1	620786	REPAIR KIT, HYD CYL, RK-1.50-801
	1	620923	SHAFT WLD, LADDER CYL 620920
	1	620924	BARREL WLD, LADDER CYL 620920
	1	607540	KICK-DOWN RELIEF VALVE, 800PSI
	1	614752	RESTRICTOR BR TEE ASSY, .042DIA
	1	616075	04-451TC-06FJX-06FJX-9 H/A
	1	618119	9/16MJIC-90-9/16MOR LBO
	1	618629	9/16MOR BRANCH TEE-9/16MJIC
	1	618668	9/16FJIC SWIV-9/16MOR ADPTR

NOTE: 1. 620920 - BOOM BREAKAWAY CYLINDER ASSEMBLY ITEMS 1-6
 2. 621057 - BOOM BREAKAWAY CYLINDER ASSEMBLY WITH FITTINGS

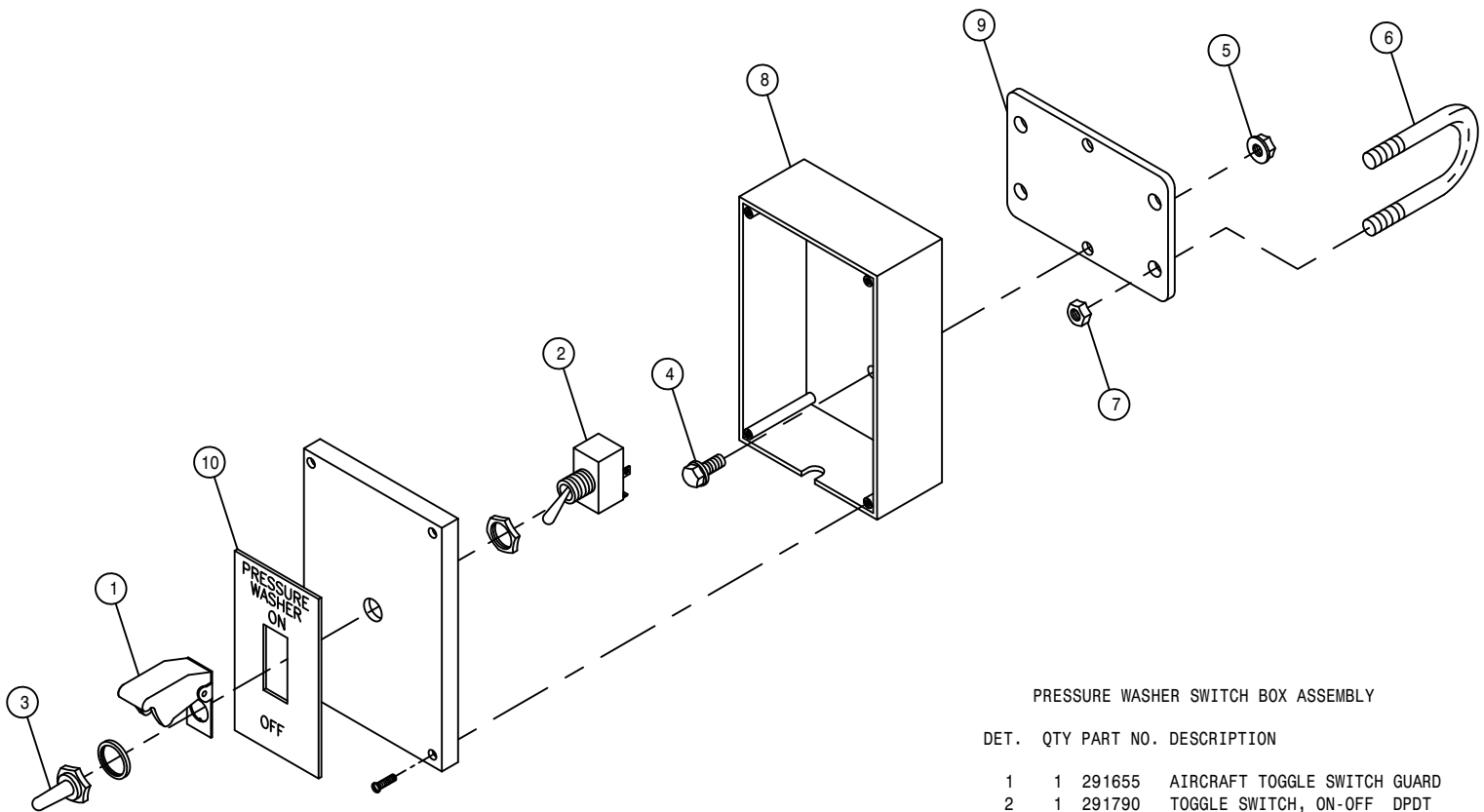

PRESSURE WASHER SWITCH BOX ASSEMBLY

DET.	QTY	PART NO.	DESCRIPTION
1	1	291655	AIRCRAFT TOGGLE SWITCH GUARD
2	1	291790	TOGGLE SWITCH, ON-OFF DPDT
3	1	470001	RUBBER BOOT W NUT FOR 298012
4	2	470118	1/4UNC X 3/4 FLANGE HEX BOLT
5	2	470121	1/4UNC HEX FLANGE LOCK NUT
6	2	473911	5/16UNC-1.31ID-2.00 U-BOLT
7	4	910002	5/16UNC HEX NUT
8	1	690738	PRESSURE WASHER SWITCH BOX
9	1	690739	PRESSURE WASHER SWITCH BOX MT
10	1	650110	DECAL,PRESSURE WASH CTRL,STS12

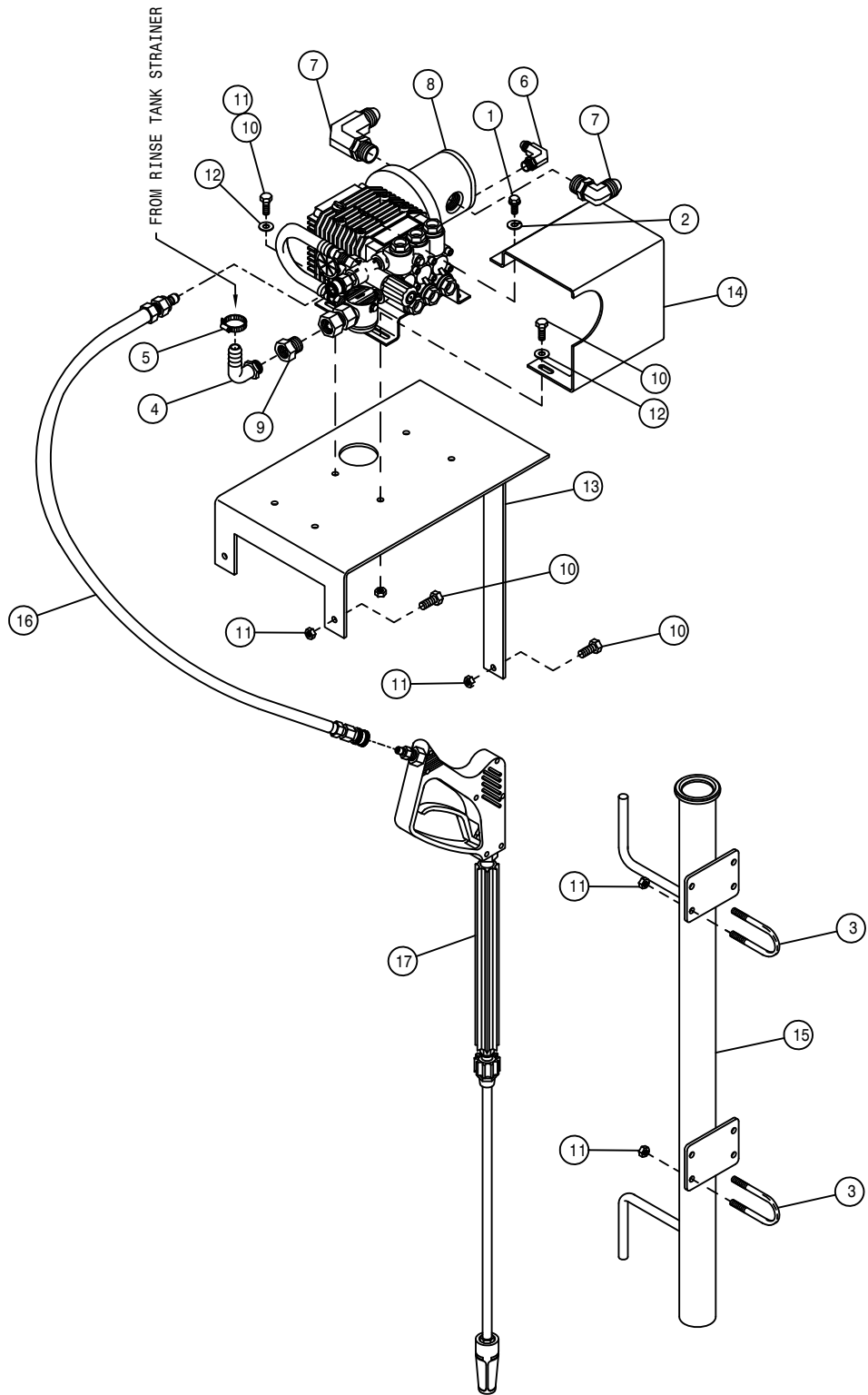

PRESSURE WASHER ASSEMBLY

DET.	QTY	PART NO.	DESCRIPTION
1	2	473803	8MM-1.25 X 16MM HEX BOLT
2	2	473804	8MM LOCK WASHER
3	4	473911	5/16UNC-1.31ID-2.00 U-BOLT
4	1	500026	3/4NPT-90-1"HOSE BARB, POLY
5	1	520090	HOSE CLAMP NO 16 STAINLESS
6	1	618119	9/16MJIC-90-9/16MOR LBO
7	2	618474	3/4MJIC-90-1 1/16MOR LBO
8	1	690672	PRESSURE WASHER,PACE 320 HYD
9	1	715449	3/4FNPT X 3/4MGHT ADPTR BRS
10	7	900064	5/16UNC X 3/4 HEX BOLT
11	15	914002	5/16UNC HEX STOVER NUT
12	4	920001	5/16 SAE FLAT WASHER
13	1	690747	PRESSURE WASHER MT WLD
14	1	690736	PRESSURE WASHER SHIELD
15	1	690732	PRESSURE WASHER WAND MT WLD
16	1	690791	HOSE, PRESSURE WASHER 690672
17	1	690673	TRIGGER GUN ASSY FOR 690672

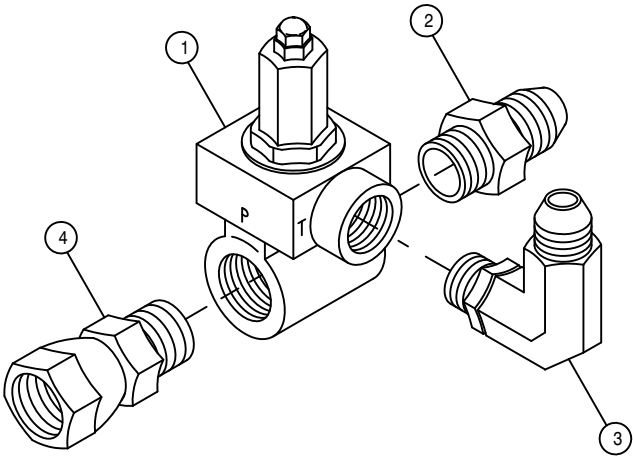

IN-LINE HYD RELIEF VALVE ASSEMBLY

DET.	QTY	PART NO.	DESCRIPTION
	1	607550	IN-LINE RELIEF VALVE, 2600 PSI
	1	611127	1 1/16MJIC-1 1/16MOR ADPTR
	1	618279	1 1/16MJIC-90-7/8MOR LBO
	1	618578	1 1/16FJIC SWIV-1 1/16MOR

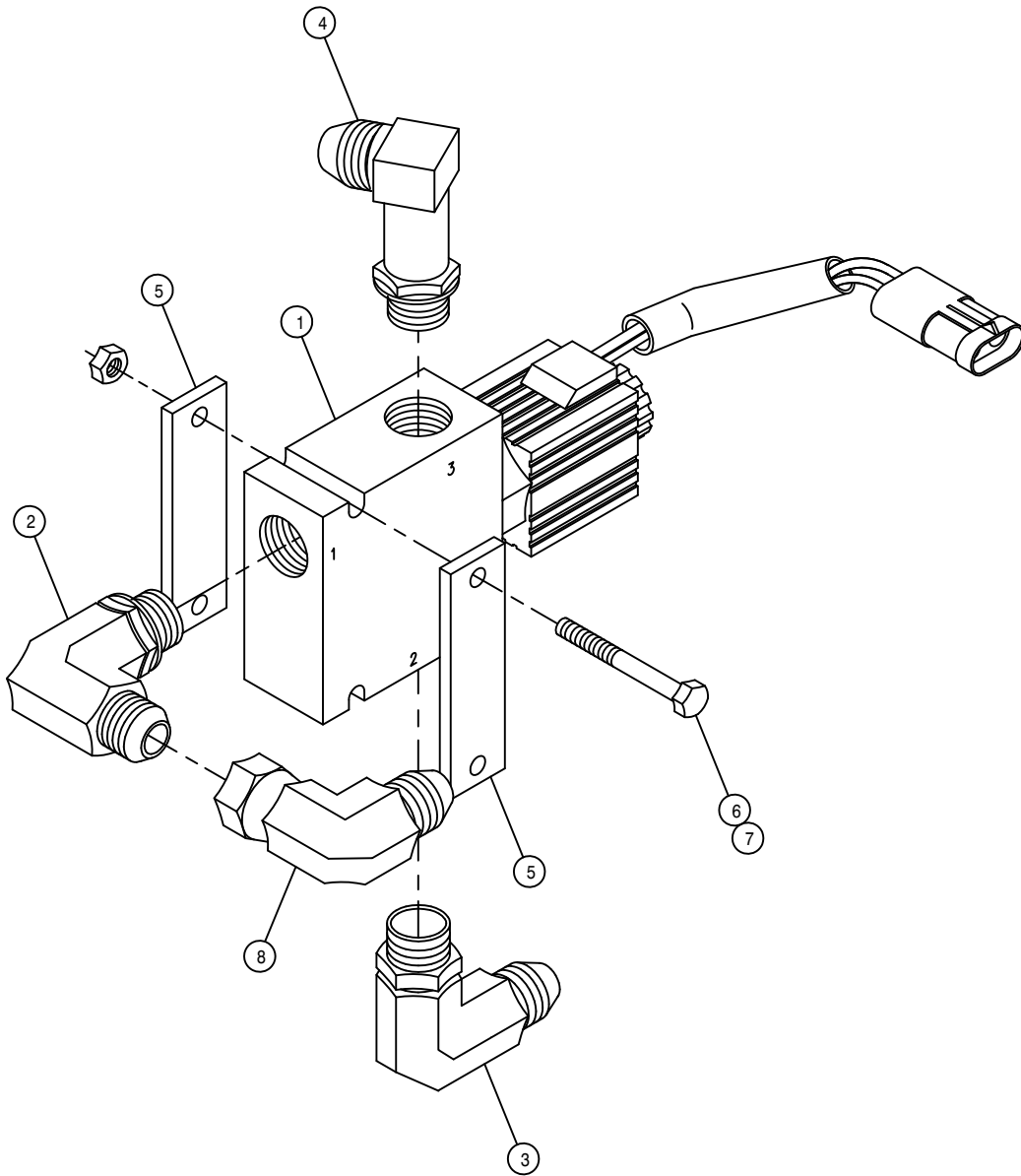

PRESSURE WASHER HYDRAULIC VALVE ASSEMBLY

DET. QTY PART NO. DESCRIPTION

1	1	606015	SIDE-FILL/WASH VLV W/SHRD ASSY
2	1	618248	1 1/16M JIC-90-1 1/16MOR LBO
3	1	618474	3/4M JIC-90-1 1/16MOR LBO
4	1	618674	1 1/16M JIC-90-1 1/16MOR XL LBO
5	2	690728	VALVE KEEPER/SPACER
6	2	900072	5/16UNC X 3" HEX BOLT
7	2	914002	5/16UNC HEX STOVER NUT
8	1	618191	1 1/16M JIC-90-1 1/16FJ SWIV LBO

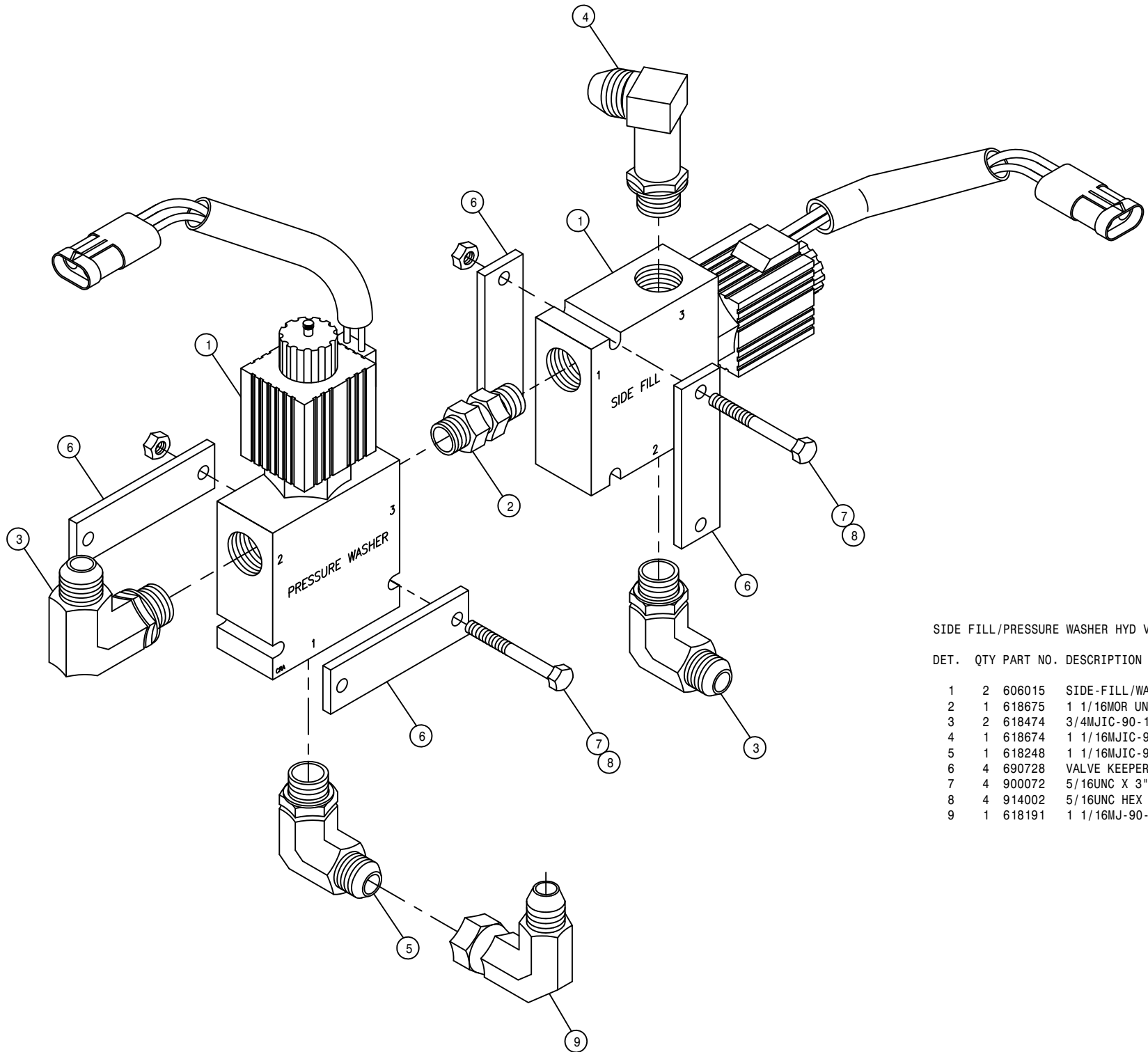

SIDE FILL/PRESSURE WASHER HYD VALVE ASSEMBLY

DET.	QTY	PART NO.	DESCRIPTION
1	2	606015	SIDE-FILL/WASH VLV W/SHRD ASSY
2	1	618675	1 1/16MOR UNION
3	2	618474	3/4MJIC-90-1 1/16MOR LBO
4	1	618674	1 1/16MJIC-90-1 1/16MOR XL LBO
5	1	618248	1 1/16MJIC-90-1 1/16MOR LBO
6	4	690728	VALVE KEEPER/SPACER
7	4	900072	5/16UNC X 3" HEX BOLT
8	4	914002	5/16UNC HEX STOVER NUT
9	1	618191	1 1/16MJ-90-1 1/16FJ SWIV LBO

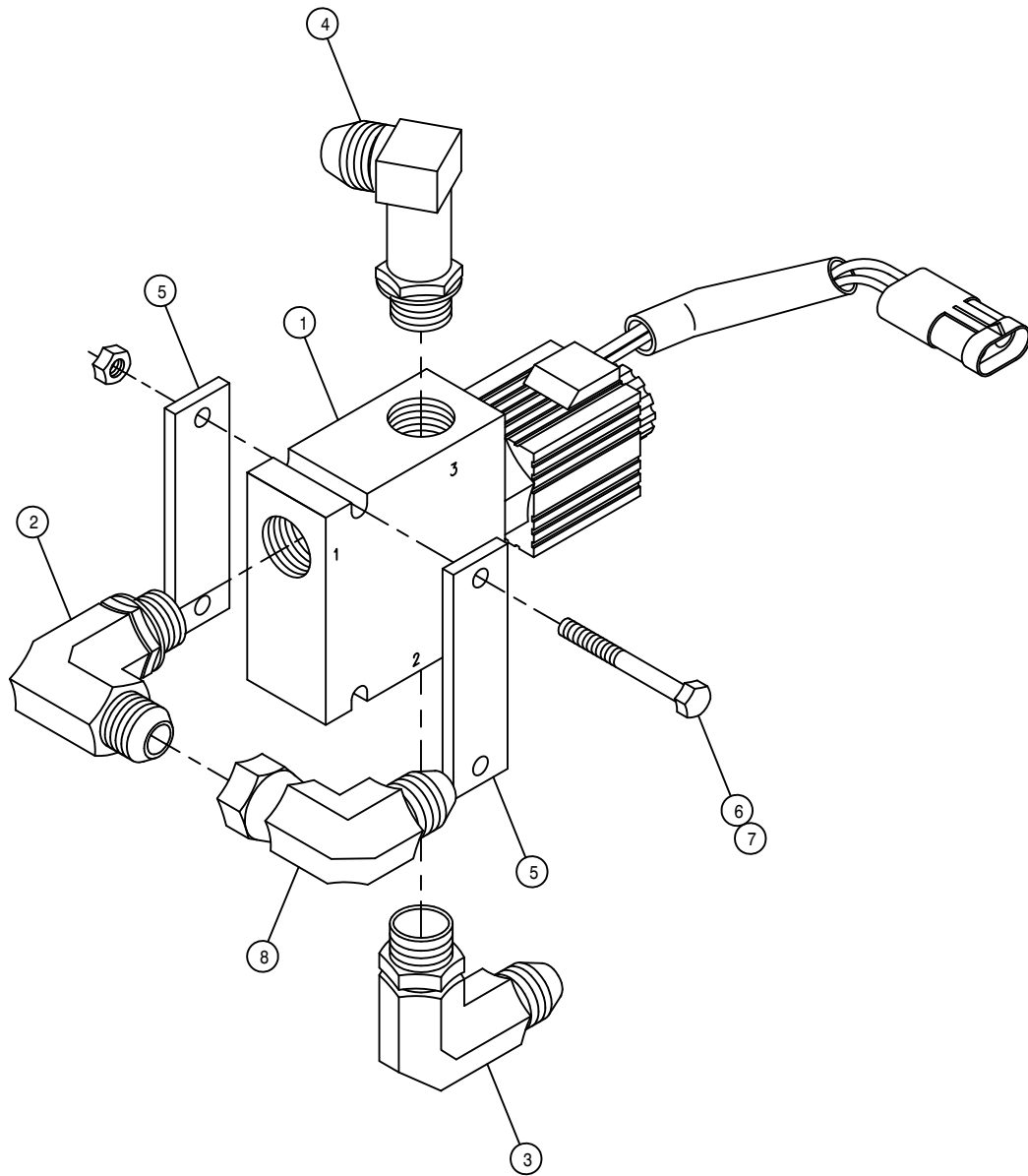

SIDE FILL HYDRAULIC VALVE ASSEMBLY

DET. QTY PART NO. DESCRIPTION

1	1	606015	SIDE-FILL/WASH VLV W/SHRD ASSY
2	1	618248	1 1/16MJC-90-1 1/16MOR LBO
3	1	618474	3/4MJIC-90-1 1/16MOR LBO
4	1	618674	1 1/16MJIC-90-1 1/16MOR XL LBO
5	2	690728	VALVE KEEPER/SPACER
6	2	900072	5/16UNC X 3" HEX BOLT
7	2	914002	5/16UNC HEX STOVER NUT
8	1	618191	1 1/16MJ-90-1 1/16FJ SWIV LBO

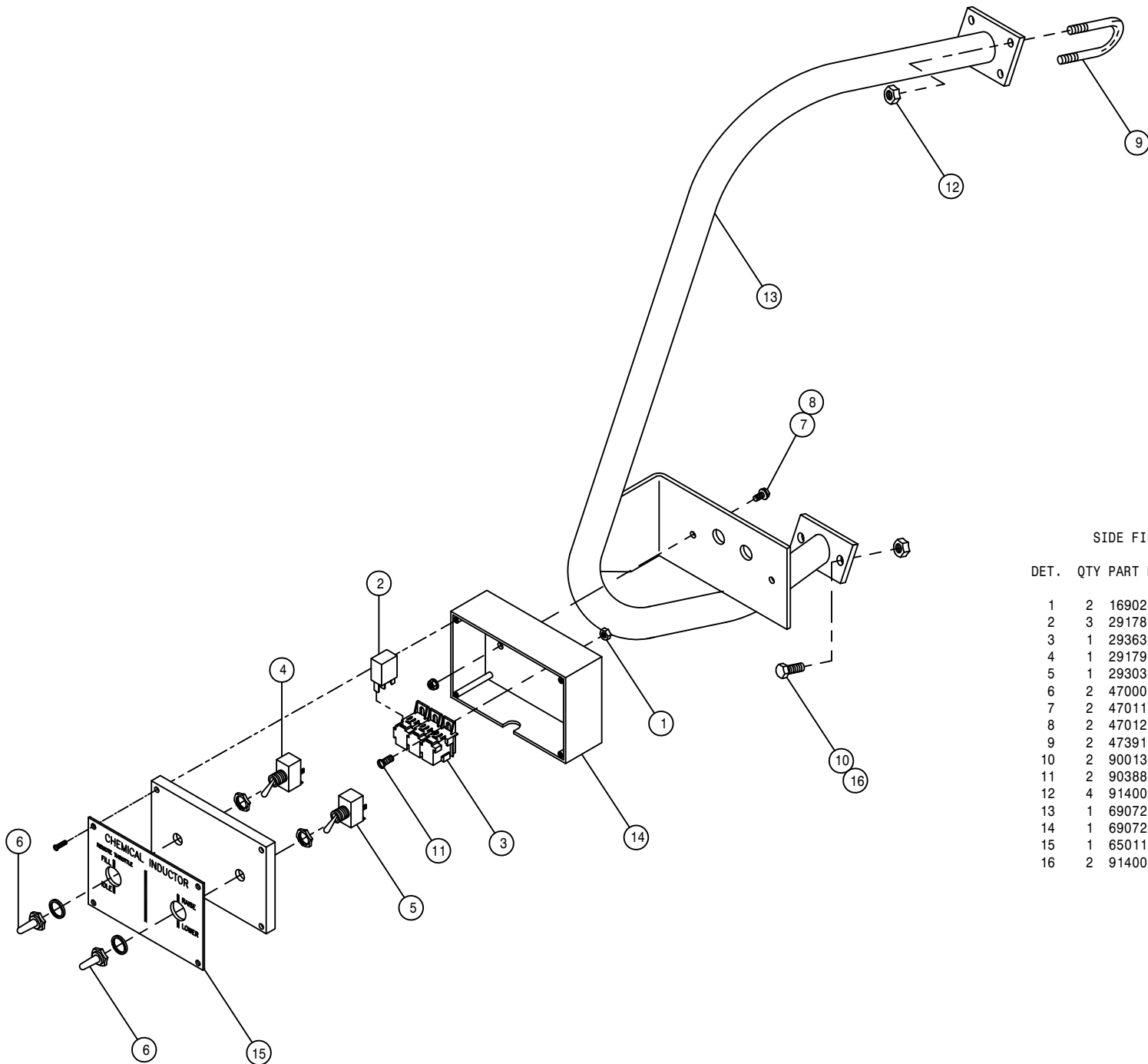

SIDE FILL SWITCH BOX ASSEMBLY

DET. QTY PART NO. DESCRIPTION

DET.	QTY	PART NO.	DESCRIPTION
1	2	169028	10-24 HEX FLANGE LOCK NUT
2	3	291781	MICRO RELAY, BOSCH 12V SPDT
3	1	293634	SIDE FILL BOX HARNESS
4	1	291790	TOGGLE SWITCH, ON-OFF DPDT
5	1	293038	TOGGLE SWITCH DPDT 15 AMP
6	2	470001	RUBBER BOOT W NUT FOR 298012
7	2	470118	1/4UNC X 3/4 FLANGE HEX BOLT
8	2	470121	1/4UNC HEX FLANGE LOCK NUT
9	2	473911	5/16UNC-1.31ID-2.00 U-BOLT
10	2	900130	3/8UNC X 1 1/4 HEX BOLT
11	2	903882	10-24 X 1/2 SLT RDHD MACH SCR
12	4	914002	5/16UNC HEX STOVER NUT
13	1	690723	CHEM IND GUARD WLD
14	1	690722	SIDE FILL SWITCH BOX
15	1	650111	DECAL, CHEM INDUCTOR CTRL. STS12
16	2	914004	3/8UNC HEX STOVER NUT

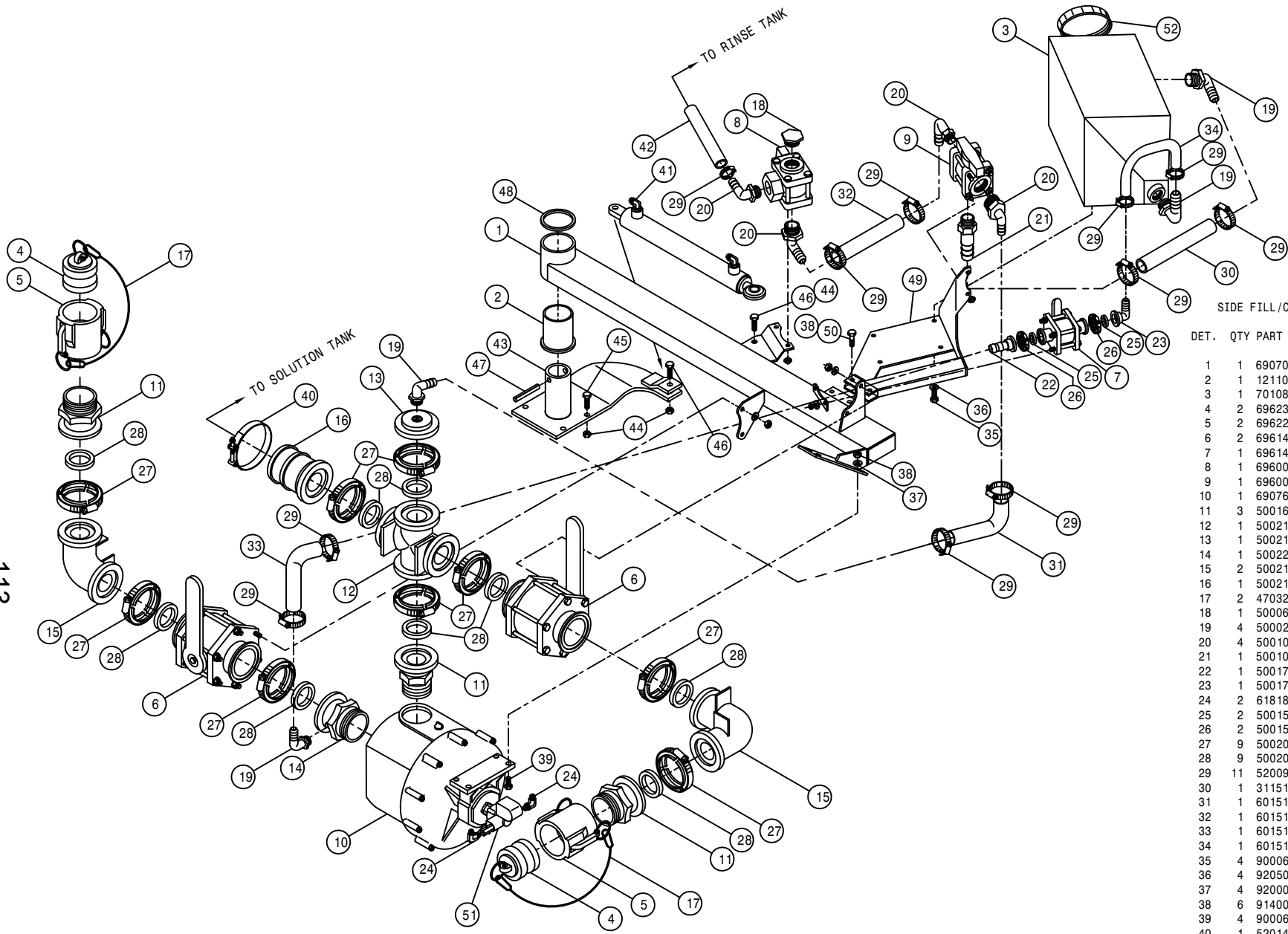

SIDE FILL/CHEMICAL INDUCTOR ASSEMBLY

DET.	QTY	PART NO.	DESCRIPTION
1	1	690703	SIDE FILL ARM WLD 2000
2	1	121101	TRANSOM PIVOT BRG,TOP ORKOT
3	1	701085	TANK, 5 GAL, SQ WHITE
4	2	696232	PLUG FOR 3.00 FEMALE COUPLER
5	2	696228	3.00FNPT-FEMALE COUPLER POLY
6	2	696149	BALL VLV, 3" FLANGE
7	1	696147	BALL VLV, 1" FLANGE
8	1	696002	BALL VLV, 1.25NP 3WAY-SIDE POLY
9	1	696001	BALL VLV, 1.25NP 3WAY-BOTT POLY
10	1	690760	BANJO PUMP,3" SIDE FILL STS12
11	3	500164	3" FLANGE-3" MNPT ADPTR POLY
12	1	500214	3"FP FLANGE CROSS
13	1	500216	3"FLANGE PLUG W/1"FNPT POLY
14	1	500220	3"FLANGE-3"MNPT W/1"FNPT POLY
15	2	500213	3"FLANGE-90-3"FLANGE LBO POLY
16	1	500210	3" FLANGE-3" HOSE BARB POLY
17	2	470322	LANYARD, 8" NYLON LOOP/LOOP
18	1	500064	1 1/4"NPT PIPE PLUG, POLY
19	4	500024	1"NPT-90-1"HOSE BARB, POLY
20	4	500102	1 1/4NPT-90-1" HOSE BARB POLY
21	1	500106	1 1/4NPT-1" HOSE BARB POLY
22	1	500171	1" FLANGE-1" HOSE BARB POLY
23	1	500173	1" FLANGE-90-1" HOSE BARB POLY
24	2	618183	3/4MJIC-90-7/8MR LBO
25	2	500157	1" FLANGE GASKET EPDM
26	2	500159	1" FLANGE CLAMP, S.S.
27	9	500208	3" FLANGE CLAMP, S.S.
28	9	500209	3" FLANGE GASKET EPDM
29	11	520090	HOSE CLAMP NO 16 STAINLESS
30	1	311510	1.00 'L' HOSE, CHEM IND TANK
31	1	601510	HOSE, 1 X 26 1BR BLK EPDM
32	1	601511	HOSE, 1 X 38 1BR BLK EPDM
33	1	601512	HOSE, 1 X 8 2F-1W EPDM
34	1	601513	HOSE, 1 X 13 2F-1W EPDM
35	4	900064	5/16UNC X 3/4 HEX BOLT
36	4	920501	5/16 LOCK WASHER
37	4	920001	5/16 SAE FLAT WASHER
38	6	914002	5/16UNC HEX STOVER NUT
39	4	900066	5/16UNC X 1 1/4 HEX BOLT
40	1	520145	356 T-BOLT HOSE CLAMP SS
41	1	621052	LADDER,SIDE FILL CYL ASSYSTS12
42	1	601459	HOSE, 1 X 245 1BR BLK EDPM
43	1	690717	CHEM IND CYL MT WLD
44	6	914008	1/2UNC HEX STOVER NUT
45	4	900265	1/2UNC X 1 1/2 HEX BOLT
46	2	900267	1/2UNC X 2" HEX BOLT
47	1	473978	ROLL PIN, 1/2 X 3 1/2 LG
48	1	690729	3.50 OD X 2.68 ID X 11 GA WASH
49	1	690773	CHEM IND TANK MT WLD 2001
50	2	900067	5/16UNC X 1 1/2 HEX BOLT
51	1	690767	HYD MTR,BANJO PMP 3"POLY690760
52	1	701155	8" LID FOR 5 GAL TANK 701085

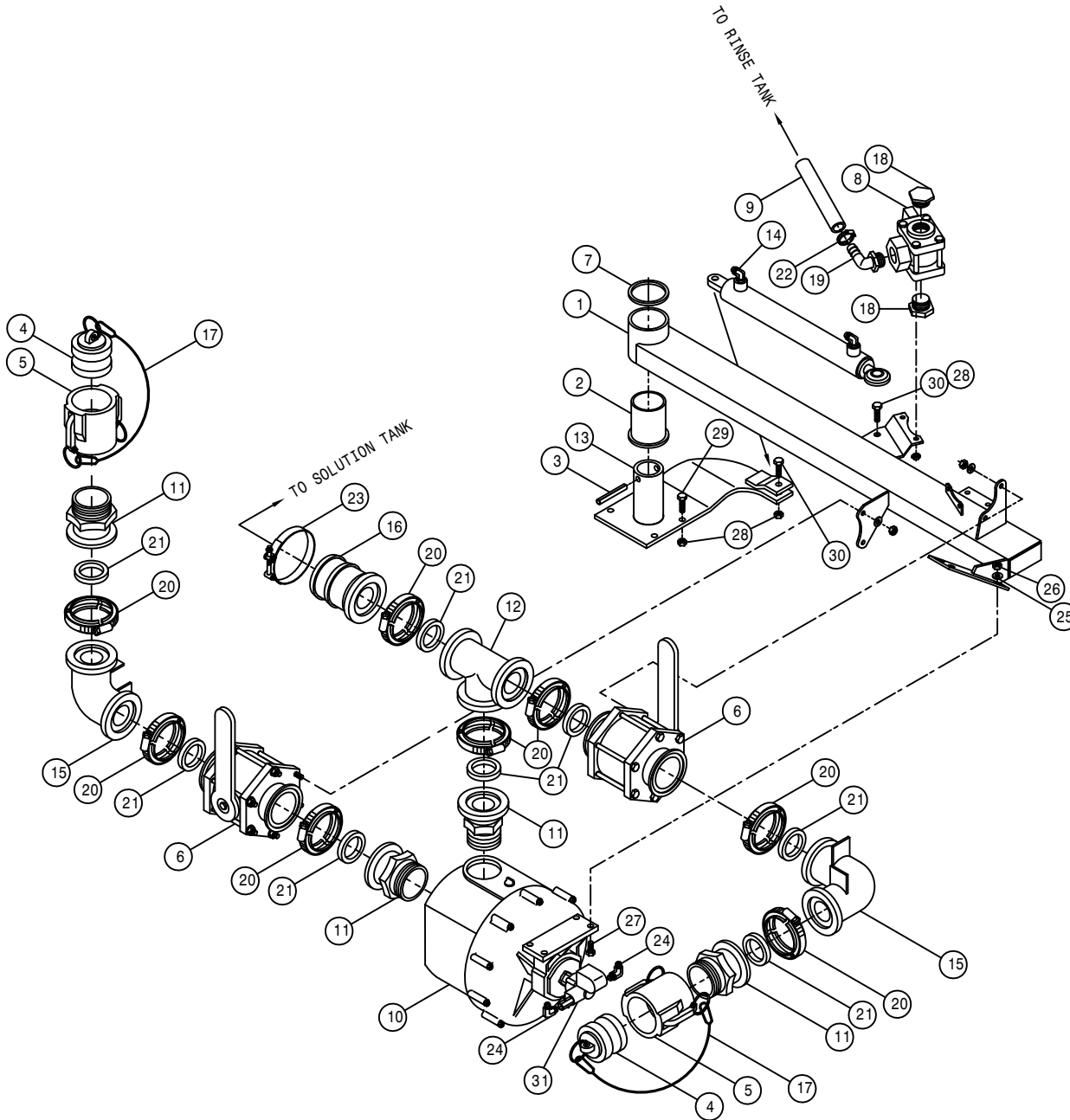

SIDE FILL ASSEMBLY

DET.	QTY	PART NO.	DESCRIPTION
	1	690703	SIDE FILL ARM WLD 2000
	1	121101	TRANSOM PIVOT BRG, TOP ORKOT
	3	473978	ROLL PIN, 1/2 X 3 1/2 LG
	4	696232	PLUG FOR 3.00 FEMALE COUPLER
	5	696228	3.00FNPT-FEMALE COUPLER POLY
	6	696149	BALL VLV, 3" FLANGE
	7	690729	3.50 OD X 2.68 ID X 11 GA WASH
	8	696002	BALL VLV, 1.25NP 3WAY-SIDE POLY
	9	601459	HOSE, 1 X 245 1BR BLK EDPM
	10	690760	BANJO PUMP, 3" SIDE FILL STS12
	11	500164	3" FLANGE-3" MNPT ADPTR POLY
	12	500217	3" FLANGE TEE POLY
	13	690717	CHEM IND CYL MT WLD
	14	621052	LADDER, SIDE FILL CYL ASSYSTS12
	15	500213	3" FLANGE-90-3" FLANGE LBO POLY
	16	500210	3" FLANGE-3" HOSE BARB POLY
	17	470322	LANYARD, 8" NYLON LOOP/LOOP
	18	500064	1 1/4"NPT PIPE PLUG, POLY
	19	500102	1 1/4NPT-90-1" HOSE BARB POLY
	20	500208	3" FLANGE CLAMP, S.S.
	21	500209	3" FLANGE GASKET EPDM
	22	520090	HOSE CLAMP NO 16 STAINLESS
	23	520145	356 T-BOLT HOSE CLAMP SS
	24	618183	3/4MJIC-90-7/8MOR LBO
	25	920001	5/16 SAE FLAT WASHER
	26	914002	5/16UNC HEX STOVER NUT
	27	900066	5/16UNC X 1 1/4 HEX BOLT
	28	914008	1/2UNC HEX STOVER NUT
	29	900265	1/2UNC X 1 1/2 HEX BOLT
	30	900267	1/2UNC X 2" HEX BOLT
	31	690767	HYD MTR, BANJO PMP 3" POLY690760

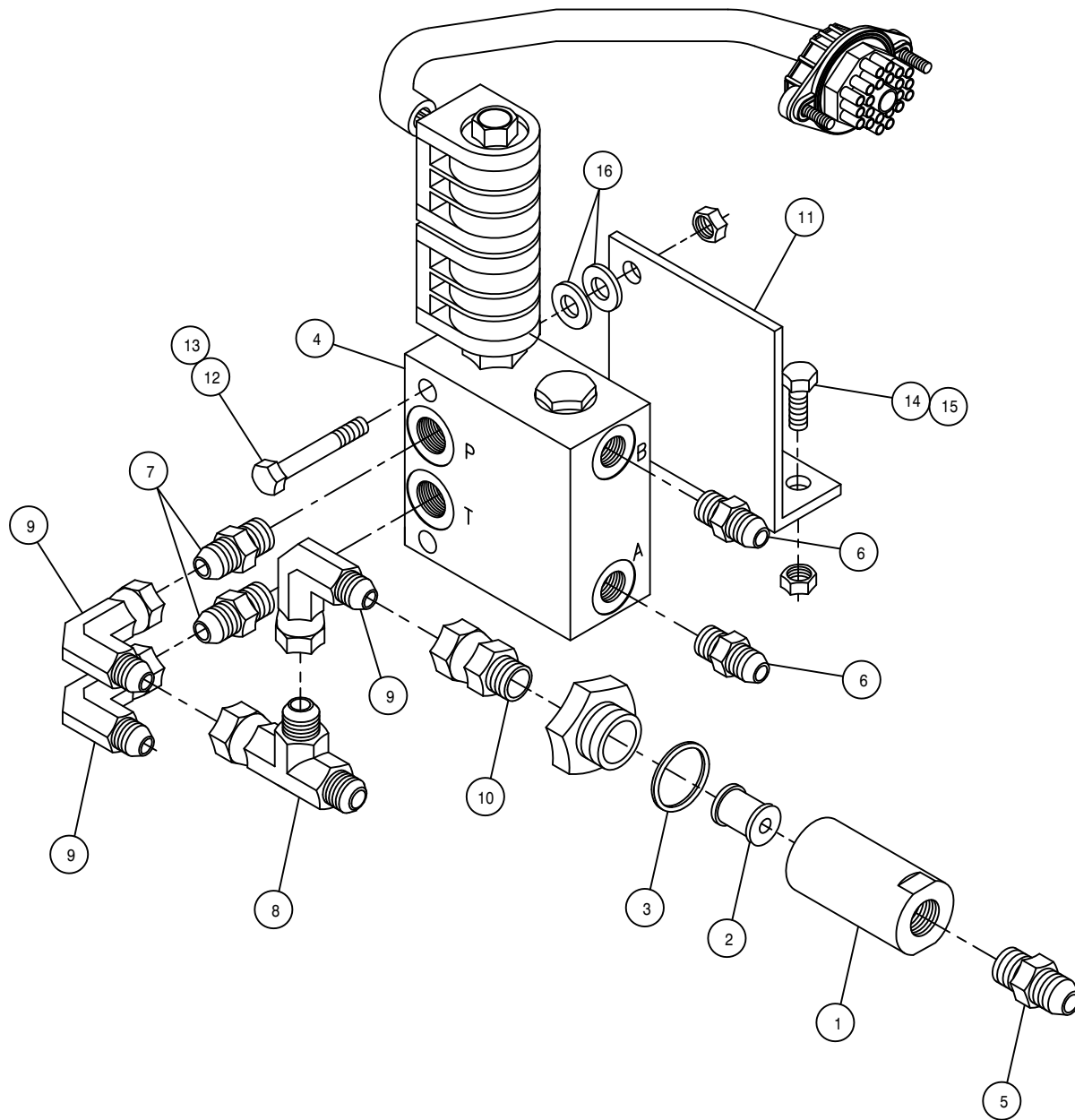

SIDE FILL HYDRAULIC VALVE ASSEMBLY

DET. QTY PART NO. DESCRIPTION

1	1	605610	HYD FILTER, INLINE 90M 3/4FOR
2	1	610459	90M FILTER & GASKET FOR610447
3	1	610462	GASKET FOR 610447 ARROW FILT
4	1	606094	SIDEFILL VLV,W/LEADS DELTA
5	1	611125	3/4MJIC-3/4MOR ADPTR
6	2	618126	9/16MJIC-9/16MOR ADPTR
7	2	618160	3/4MJIC-7/16MOR ADPTR
8	1	618451	3/4FJIC SW RUN TEE-3/4MJIC
9	3	618609	3/4MJIC-90-3/4FJIC SWIV LBO
10	1	618669	3/4FJIC SWIV-3/4MOR ADPTR
11	1	690819	SIDEFILL HYD VLV MT, STS10 02
12	2	900086	5/16UNC X 2 1/4 HEX BOLT
13	2	914002	5/16UNC HEX STOVER NUT
14	2	900129	3/8UNC X 1" HEX BOLT
15	2	914004	3/8UNC HEX STOVER NUT
16	4	920001	5/16 SAE FLAT WASHER

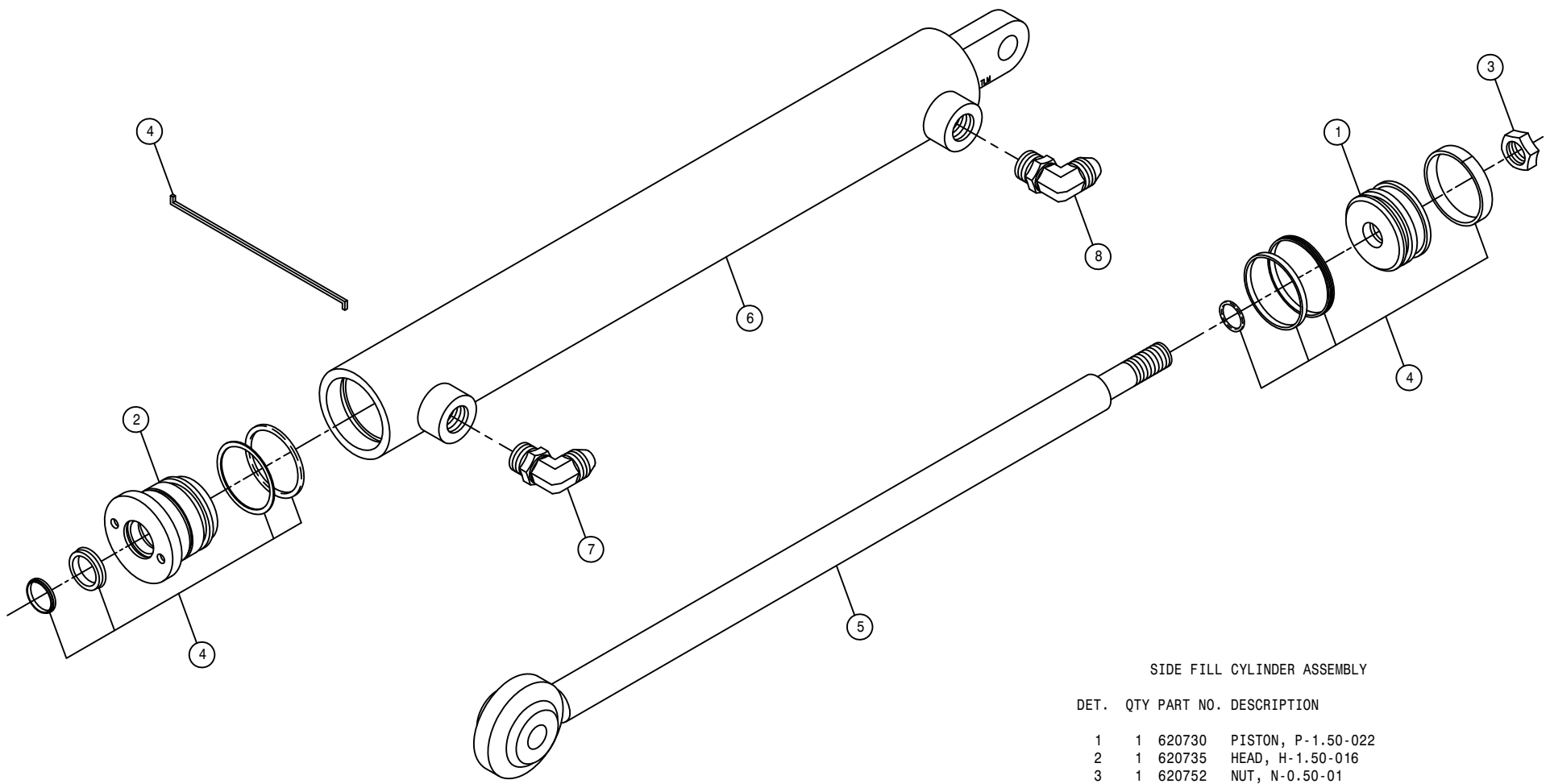

SIDE FILL CYLINDER ASSEMBLY

DET.	QTY	PART NO.	DESCRIPTION
	1	620730	PISTON, P-1.50-022
	1	620735	HEAD, H-1.50-016
	1	620752	NUT, N-0.50-01
	1	620786	REPAIR KIT, HYD CYL, RK-1.50-801
	1	620923	SHAFT WLD, LADDER CYL 620920
	1	620924	BARREL WLD, LADDER CYL 620920
	1	614750	.042 ELBOW ASSY, 9/16MOR 90D
	1	618119	9/16MJIC-90-9/16MOR LBO

NOTE: 1. 620920 - SIDE FILL CYLINDER ASSEMBLY ITEMS 1-6
 2. 621052 - SIDE FILL CYLINDER ASSEMBLY WITH FITTINGS

FRONT FILL ASSEMBLY

DET. QTY PART NO. DESCRIPTION

DET.	QTY	PART NO.	DESCRIPTION
1	1	470322	LANYARD, 8" NYLON LOOP/LOOP
2	1	500063	1"NPT PIPE PLUG, POLY
3	1	500074	1"NPT-1" HOSE BARB, POLY
4	1	500164	3" FLANGE-3" MNPT ADPTR POLY
5	2	500208	3" FLANGE CLAMP, S.S.
6	2	500209	3" FLANGE GASKET EPDM
7	1	500210	3" FLANGE-3" HOSE BARB POLY
8	1	695900	BALL VALVE 1IN FNPT POLY
9	1	696149	BALL VLV, 3" FLANGE
10	1	696228	3.00FNPT-FEMALE COUPLER POLY
11	1	696232	PLUG FOR 3.00 FEMALE COUPLER
12	1	470253	HYD DAMPER, 100LB,4.0 STROKE
13	2	470254	BALL SOCKET, M6 THD X 10MM
14	2	470255	BALL STUD,5/16-18 THD X 10MM
15	2	470256	SAFTY CLIP, 10MM BALL SOCKET
16	2	920501	5/16 LOCK WASHER
17	2	910002	5/16UNC HEX NUT
18	1	690690	FRT FILL SUPP ARM WLD
19	1	690698	FRT FILL SUPP ARM REL WLD
20	1	690701	FRT FILL SUPP ARM LATCH PIN
21	1	472316	ROLL PIN, 5/16 X 1 1/2
22	1	482017	SPRING
23	1	900066	5/16UNC X 1 1/4 HEX BOLT
24	1	914002	5/16UNC HEX STOVER NUT
25	1	920006	3/4 SAE FLAT WASHER
26	1	900418	3/4UNC X 7" HEX BOLT
27	1	914012	3/4UNC HEX STOVER NUT
28	1	601497	HOSE, 1 X 200 1BR BLK EPDM
29	1	601509	HOSE, 3 X 96 POLY HELIX EPDM
30	1	520145	356 T-BOLT HOSE CLAMP SS
31	1	520090	HOSE CLAMP NO 16 STAINLESS
32	1	785007	NOB,1 3/16" BALL,RED,3/8-16

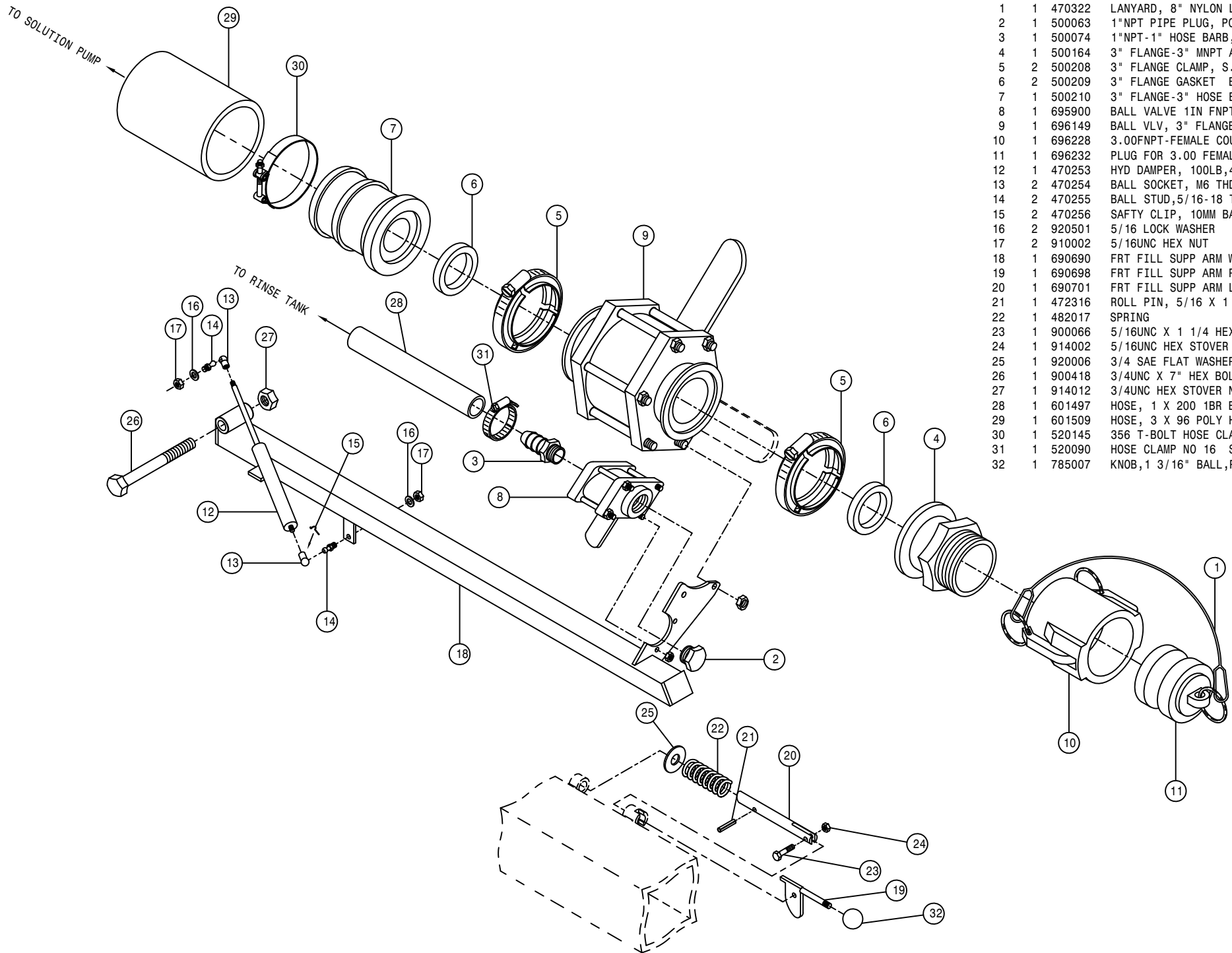

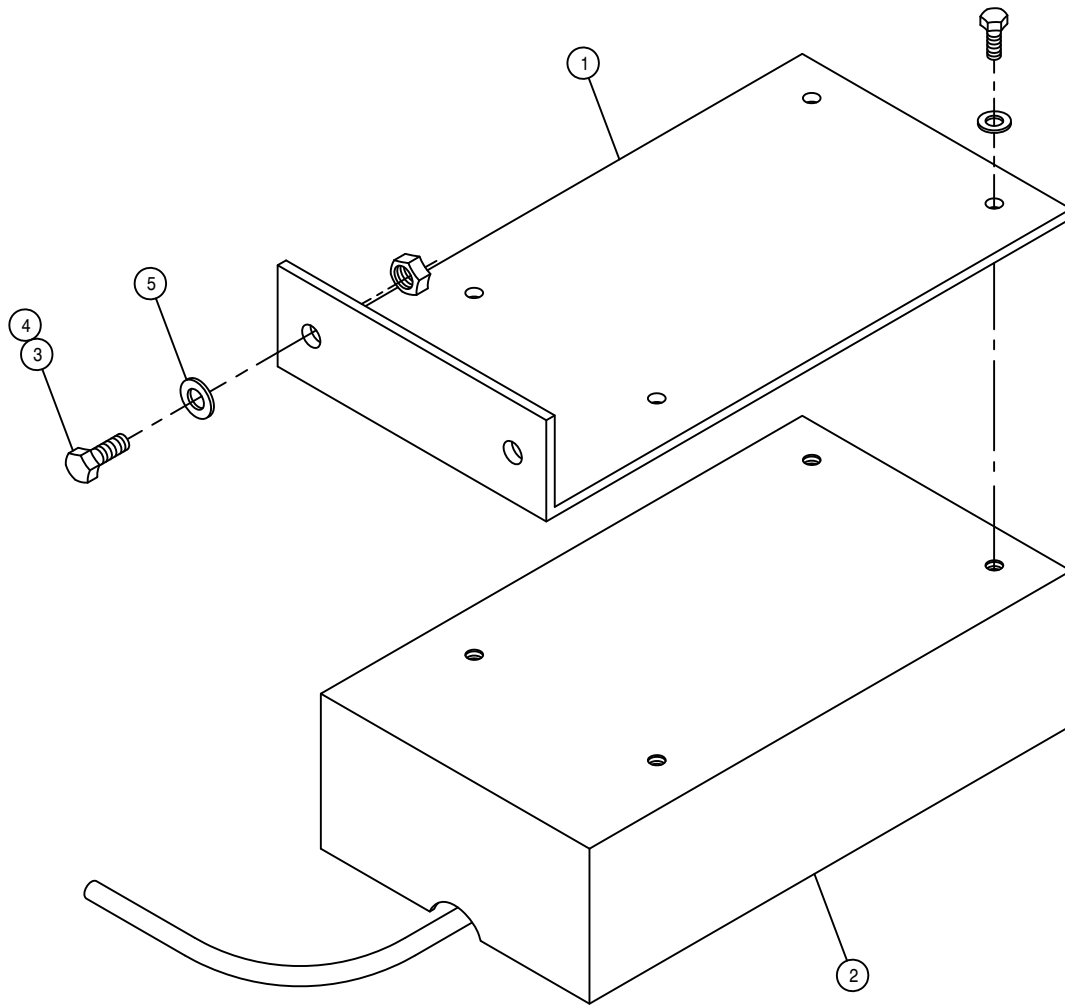

RADAR OPTION

DET. QTY PART NO. DESCRIPTION

1	1	342857	RADAR MTG BRKT
2	1	690599	RAVEN RADAR UNIT W/CABLE
3	2	900129	3/8UNC X 1" HEX BOLT
4	2	914004	3/8UNC HEX STOVER NUT
5	2	920002	3/8 SAE FLAT WASHER

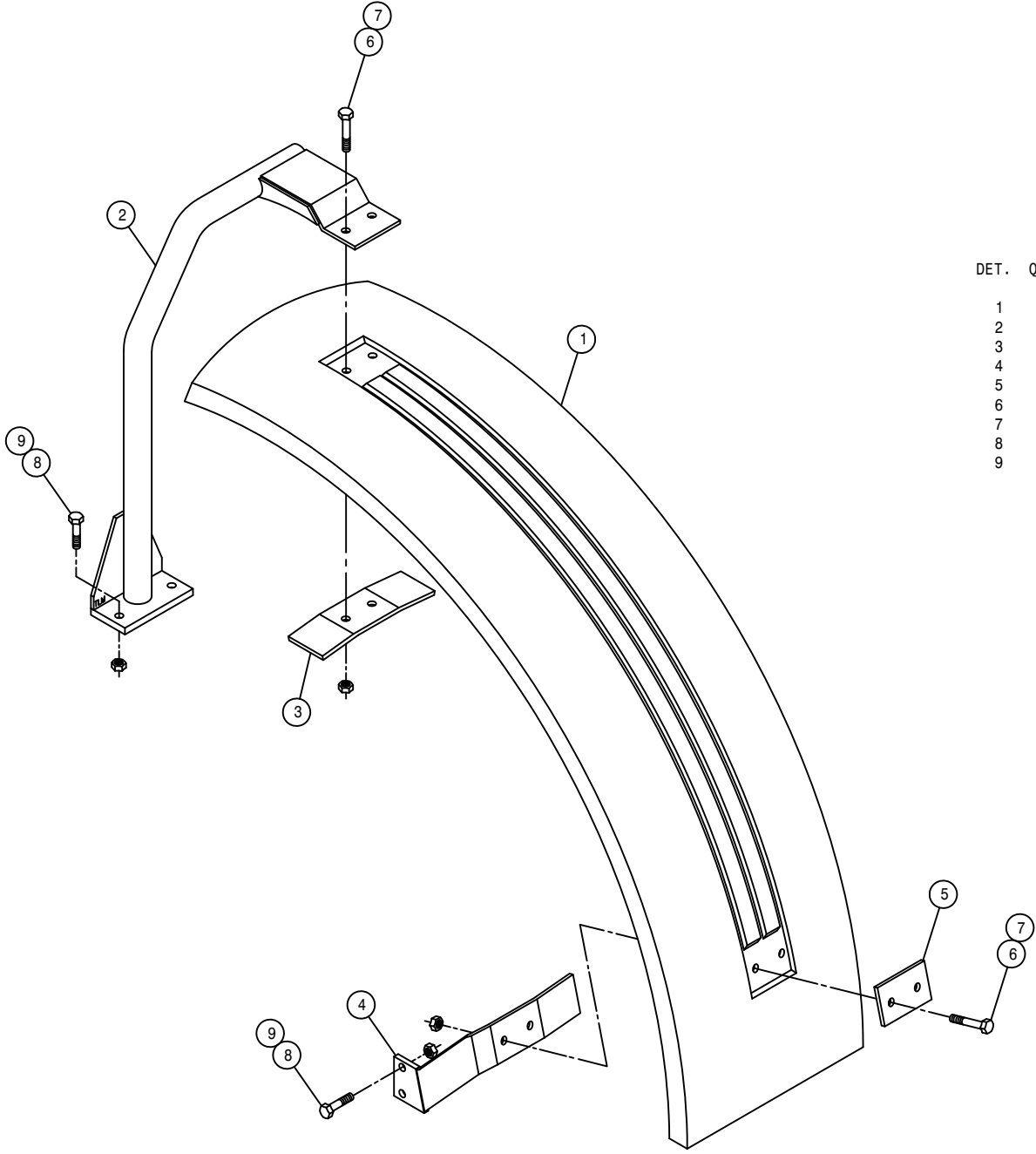

RIGHT FENDER ASSEMBLY

DET.	QTY	PART NO.	DESCRIPTION	
1	1	359151	FENDER, STS12	2000
2	1	359152	RH FENDER MT WLD	STS12
3	1	359160	FENDER MT KEEPER	STS12
4	1	359162	RH FENDER SUPP BRKT WLD	STS12
5	1	359167	FENDER SUPPORT KEEPER	STS12
6	4	473845	12MM-1.75 X 65MM HEX BOLT	
7	4	473846	12MM-1.75 HEX STOVER NUT	
8	4	900266	1/2UNC X 1 3/4 HEX BOLT	
9	4	914008	1/2UNC HEX STOVER NUT	

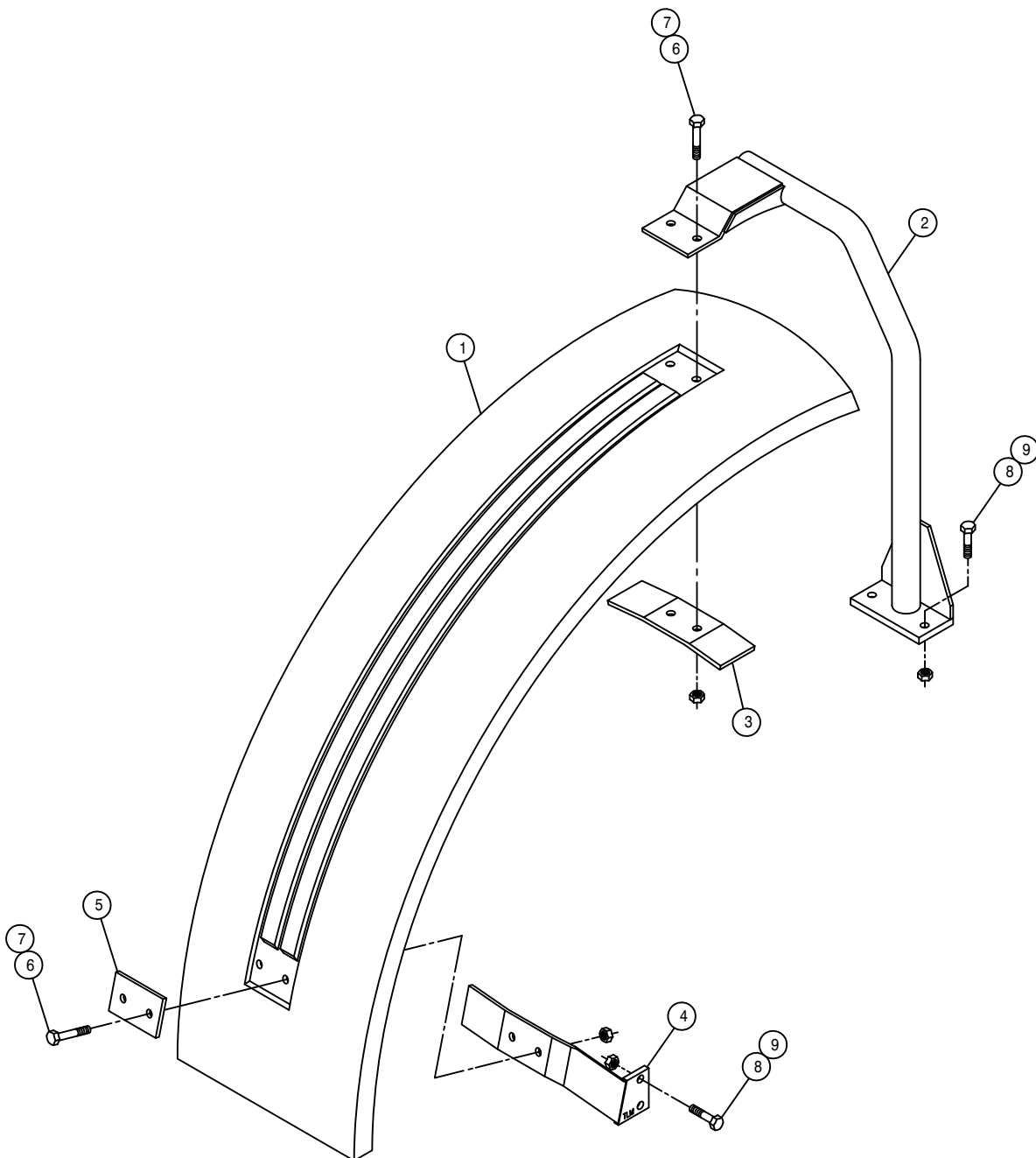

LEFT FENDER ASSEMBLY

DET.	QTY	PART NO.	DESCRIPTION	
1	1	359151	FENDER, STS12	2000
2	1	359153	LH FENDER MT WLD	STS12
3	1	359160	FENDER MT KEEPER	STS12
4	1	359163	LH FENDER SUPP BRKT WLD	STS12
5	1	359167	FENDER SUPPORT KEEPER	STS12
6	4	473845	12MM-1.75 X 65MM HEX BOLT	
7	4	473846	12MM-1.75 HEX STOVER NUT	
8	4	900266	1/2UNC X 1 3/4 HEX BOLT	
9	4	914008	1/2UNC HEX STOVER NUT	

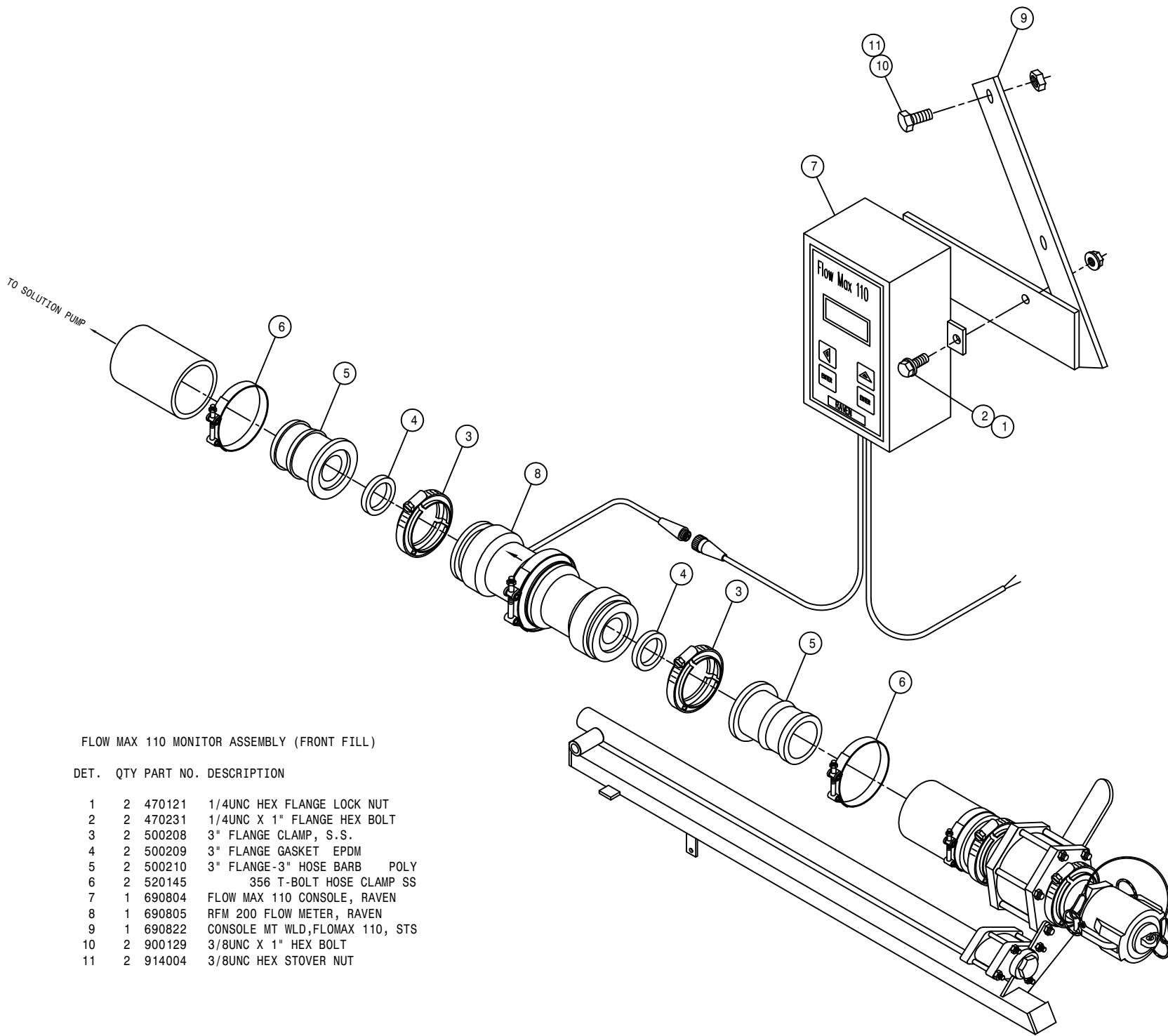

FLOW MAX 110 MONITOR ASSEMBLY (FRONT FILL)

DET. QTY PART NO. DESCRIPTION

1	2	470121	1/4UNC HEX FLANGE LOCK NUT
2	2	470231	1/4UNC X 1" FLANGE HEX BOLT
3	2	500208	3" FLANGE CLAMP, S.S.
4	2	500209	3" FLANGE GASKET EPDM
5	2	500210	3" FLANGE-3" HOSE BARB POLY
6	2	520145	356 T-BOLT HOSE CLAMP SS
7	1	690804	FLOW MAX 110 CONSOLE, RAVEN
8	1	690805	RFM 200 FLOW METER, RAVEN
9	1	690822	CONSOLE MT WLD, FLOMAX 110, STS
10	2	900129	3/8UNC X 1" HEX BOLT
11	2	914004	3/8UNC HEX STOVER NUT

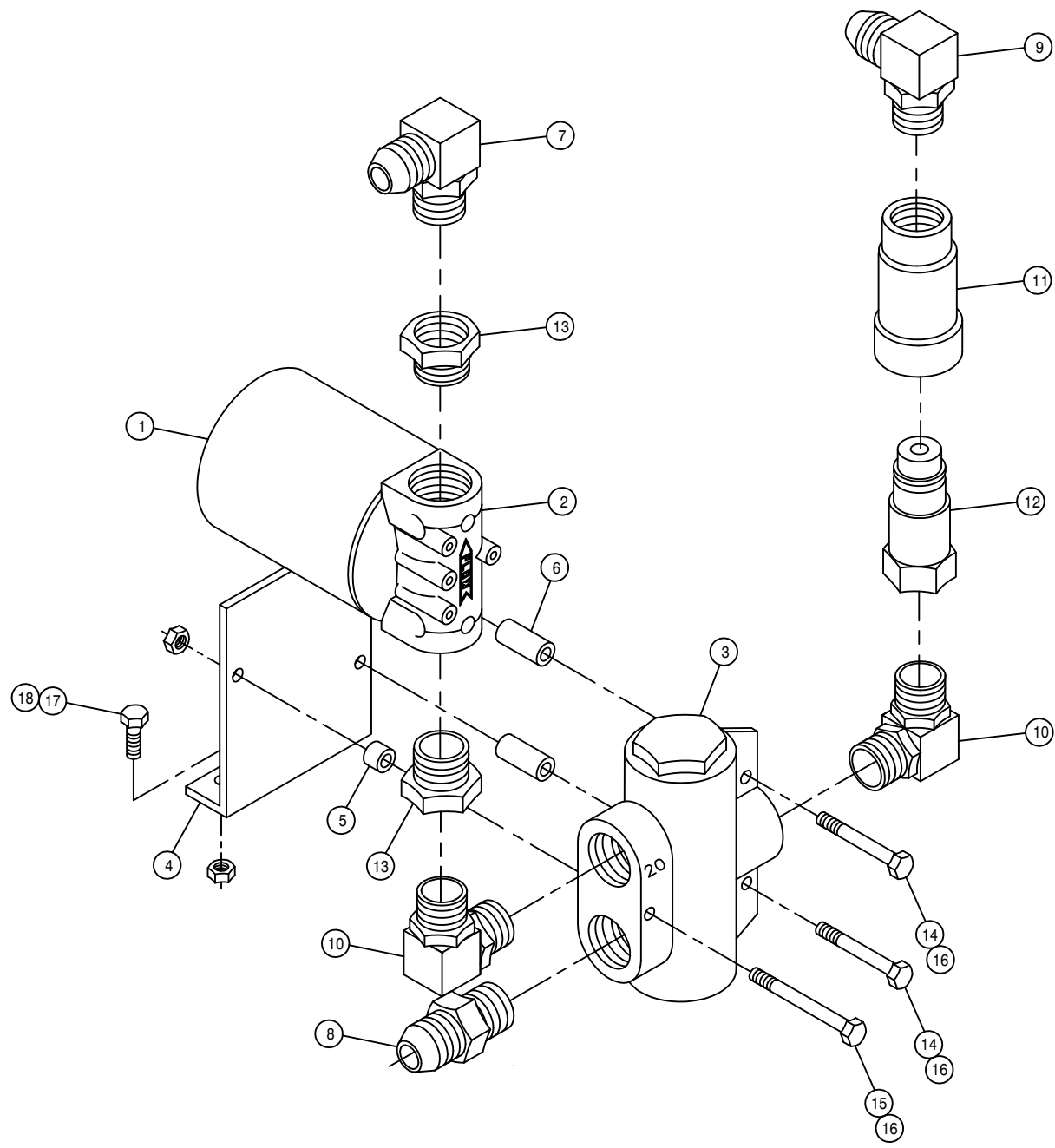

BG420 FLOW DIVIDER ASSEMBLY

DET.	QTY	PART NO.	DESCRIPTION
	1	605612	FILTER, 10 MICRON ZINGA
	1	605614	FILTER HEAD, 1 7/8FOR ZINGA
	1	606074	FLO DIV BG420 20GPM PRI 16FOR
	1	606078	BG420 FLO DIV MT PLT, STS12C
	1	606079	BG420 FLO DIV MT SPACER, SHORT
	2	606080	BG420 FLO DIV MT SPACER, LONG
	1	618178	1 5/16MJIC-90-1 5/16MOR LBO
	1	618186	1 5/16MJIC-1 5/16MOR ADPTR
	1	618476	1 5/8MJIC-90-1 5/16MOR LBO
	2	618685	1 5/16MOR-90-1 5/16MOR LBO
	1	618686	HYD QUICK CPLR,FEMALE 1.00UNF
	1	618687	HYD QUICK CPLR, MALE 1.00UNF
	2	618707	1 7/8MOR-1 5/16FOR ADPTR
	2	900007	1/4UNC X 2" HEX BOLT
	1	900009	1/4UNC X 2 3/4 HEX BOLT
	3	914000	1/4UNC HEX STOVER NUT
	2	900065	5/16UNC X 1" HEX BOLT
	2	914002	5/16UNC HEX STOVER NUT

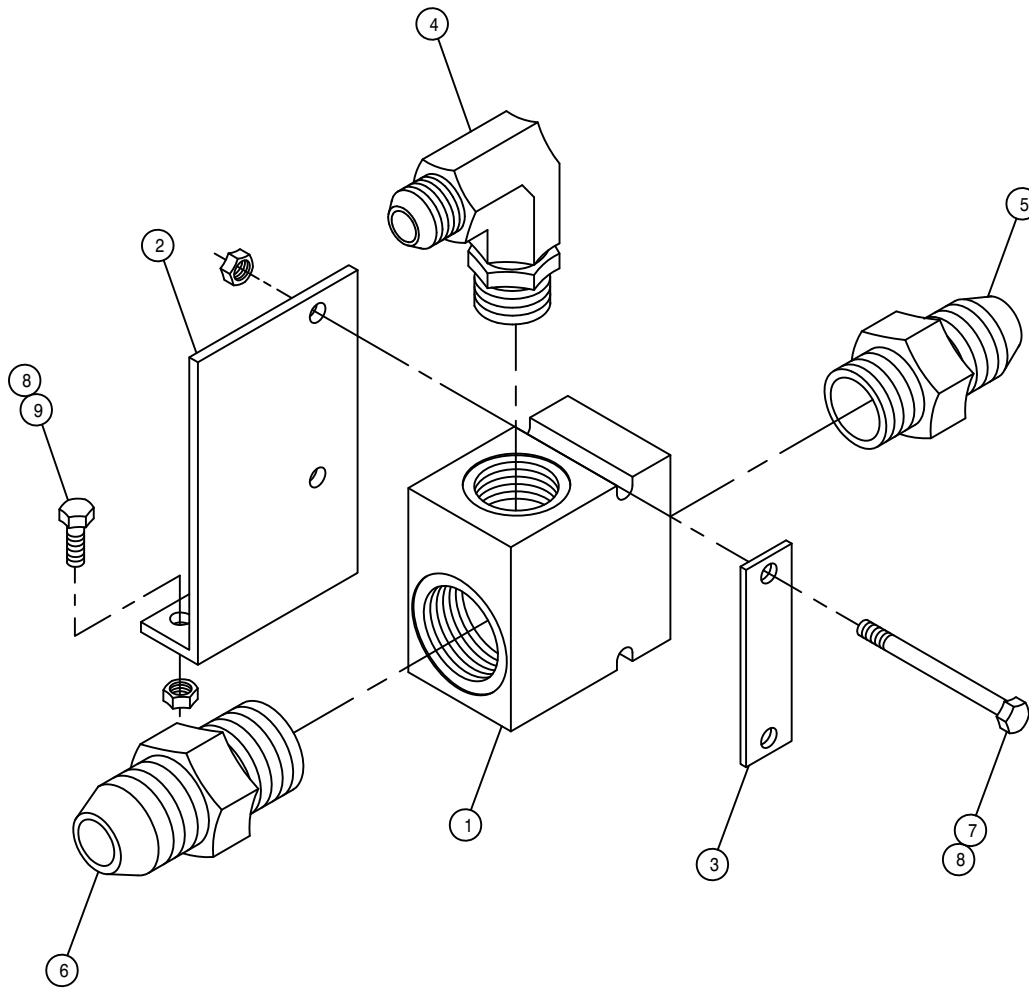

MANIFOLD ASSEMBLY

DET. QTY PART NO. DESCRIPTION

1	1	606075	MANIFOLD, 1 5/16FOR & 1 5/8FOR
2	1	606081	MANIFOLD MT PLT, STS12 COMBO
3	1	606082	MANIFOLD MT KEEPER, STS12 COMBO
4	1	618178	1 5/16MJIC-90-1 5/16MOR LBO
5	1	618186	1 5/16MJIC-1 5/16MOR ADPTR
6	1	618472	1 5/8MJIC-1 5/8MOR ADPTR
7	2	900072	5/16UNC X 3" HEX BOLT
8	4	914002	5/16UNC HEX STOVER NUT
9	2	900065	5/16UNC X 1" HEX BOLT

RECEPTACLE PANEL ASSEMBLY

DET. QTY PART NO. DESCRIPTION

1	1	003004	FRT RECEPTACLE MT WLD, STSC
2	2	291688	CAP FOR #13 SHELL RECEPTACLE
3	2	291754	AMP RECEPTACLE CAP, 17-SHELL
4	1	291838	CAP FOR #23 SHELL RECEPTACLE
5	2	291839	CAP, MINI-CHG 1"-16UN 6-8P
6	1	293046	CAP FOR #11 SHELL RECEPTACLE
7	1	293642	JUMPER HARNESS,CAB-RECEPTCL MT
8	1	293670	POWER HARNESS, MAIN STS COMBO
9	1	293672	FLO CTRL CABLE,5FT RAVEN STSC
10	1	293679	PHOTO EYE HARNESS, STS COMBO
11	1	293681	LIFT VLV HARNESS STS COMBO
12	1	293683	ACTUATOR HARNESS, STS COMBO
13	2	470349	GROMMET, .875ID .125GW 1.250GD
14	12	473989	6-32 X 3/4 BUTTON SOC CAP SCR
15	2	900034	1/4UNC X 7" HEX BOLT
16	12	910022	6-32 HEX NUT
17	2	914000	1/4UNC HEX STOVER NUT

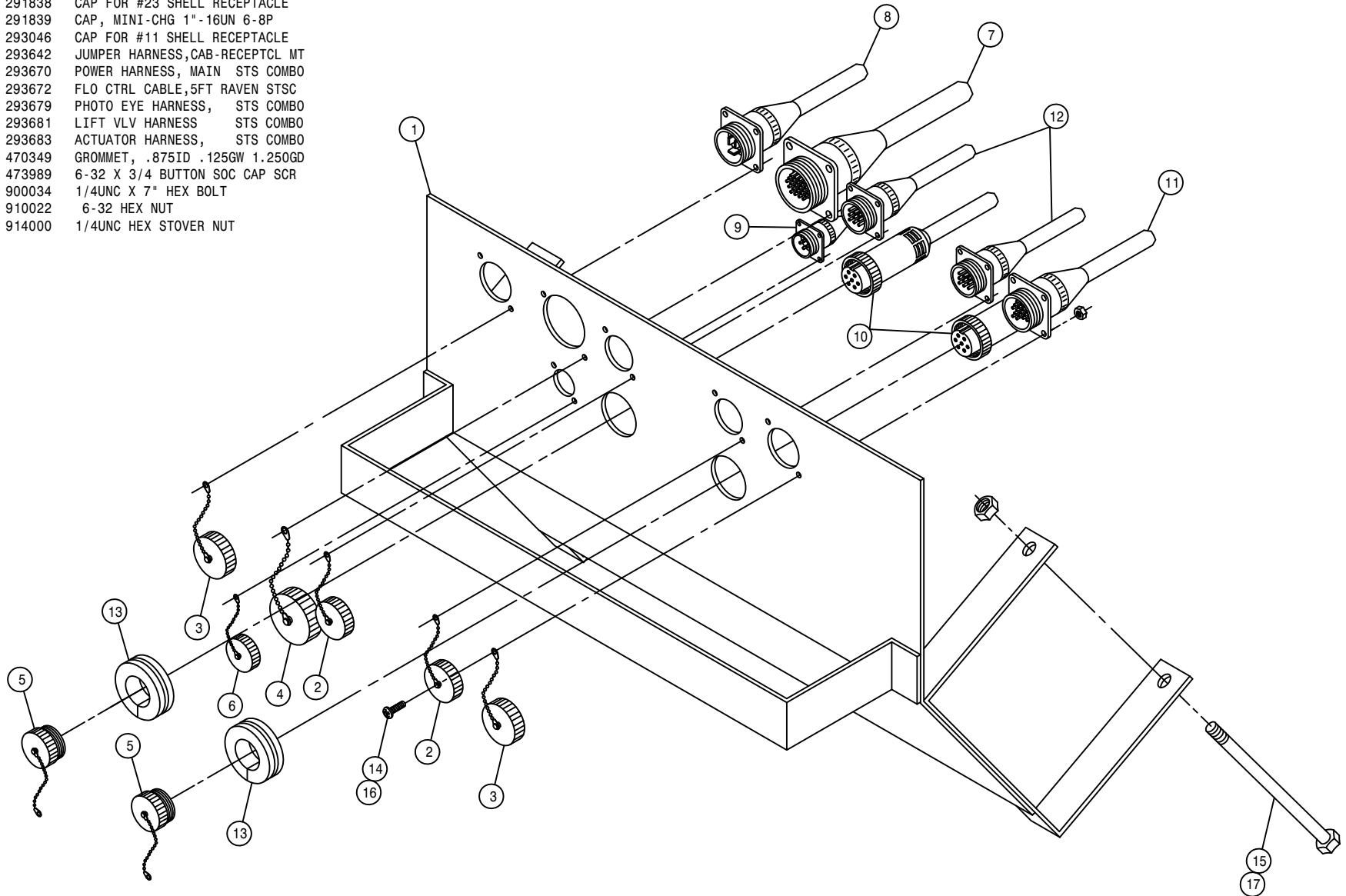

FOLD/CONTROL VALVE RELAY BOX ASSEMBLY

DET. QTY PART NO. DESCRIPTION

1	1	003008	FOLD/MTR CTRL RELAY BOX WLD
2	1	003014	FOLD/MTR CTRL RELAY MT PANEL
3	1	003015	FOLD/MTR CTRL RELAY BOX COVER
4	4	193022	STICKERTITE 1/4 X 3/4
5	1	291552	CIRCUIT BREAKER, 20AMP, INLINEMT
6	10	291781	MICRO RELAY, BOSCH 12V SPDT
7	1	293093	TERMINAL BLOCK 6 POS - 2 ROW
8	1	293689	FOLD/CTRL VLV RELAY HARNESS
9	15	470165	10-32 NUTSERT .020-.100 MATL
10	4	470351	#10 X 1/2 BONDED SEALING WASH
11	16	473989	6-32 X 3/4 BUTTON SOC CAP SCR
12	4	903710	10-32X5/8 PHIL PANHD MACH SCR
13	2	903889	10-32 X 3/4 SLT RDHD MACH SCR
14	9	903883	10-32 X 1/2 SLT RDHD MACH SCR
15	16	910022	6-32 HEX NUT
16	2	003013	FOLD/MTR CTRL RELAY BOX CLAMP
17	4	470118	1/4UNC X 3/4 FLANGE HEX BOLT
18	4	470121	1/4UNC HEX FLANGE LOCK NUT

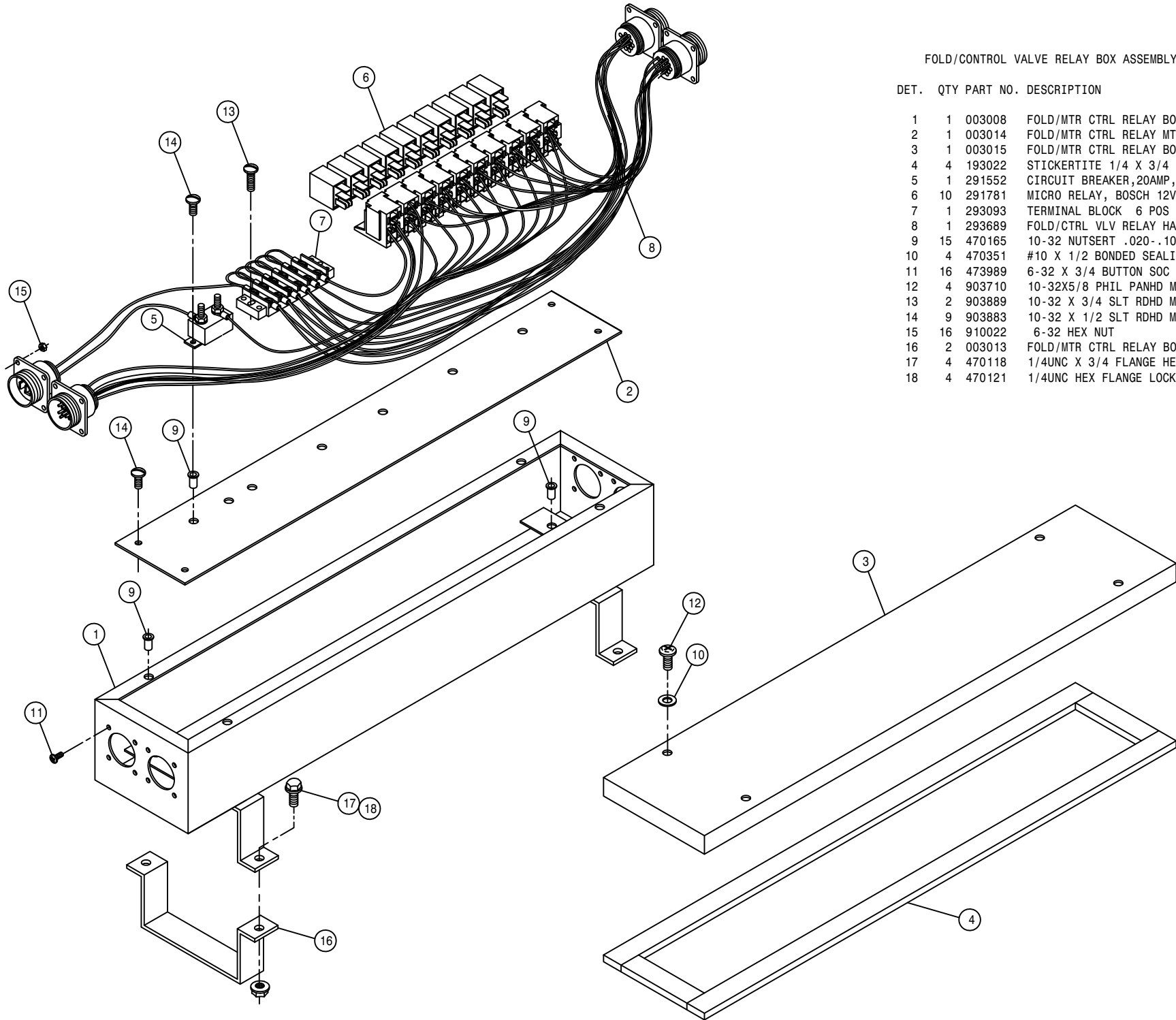

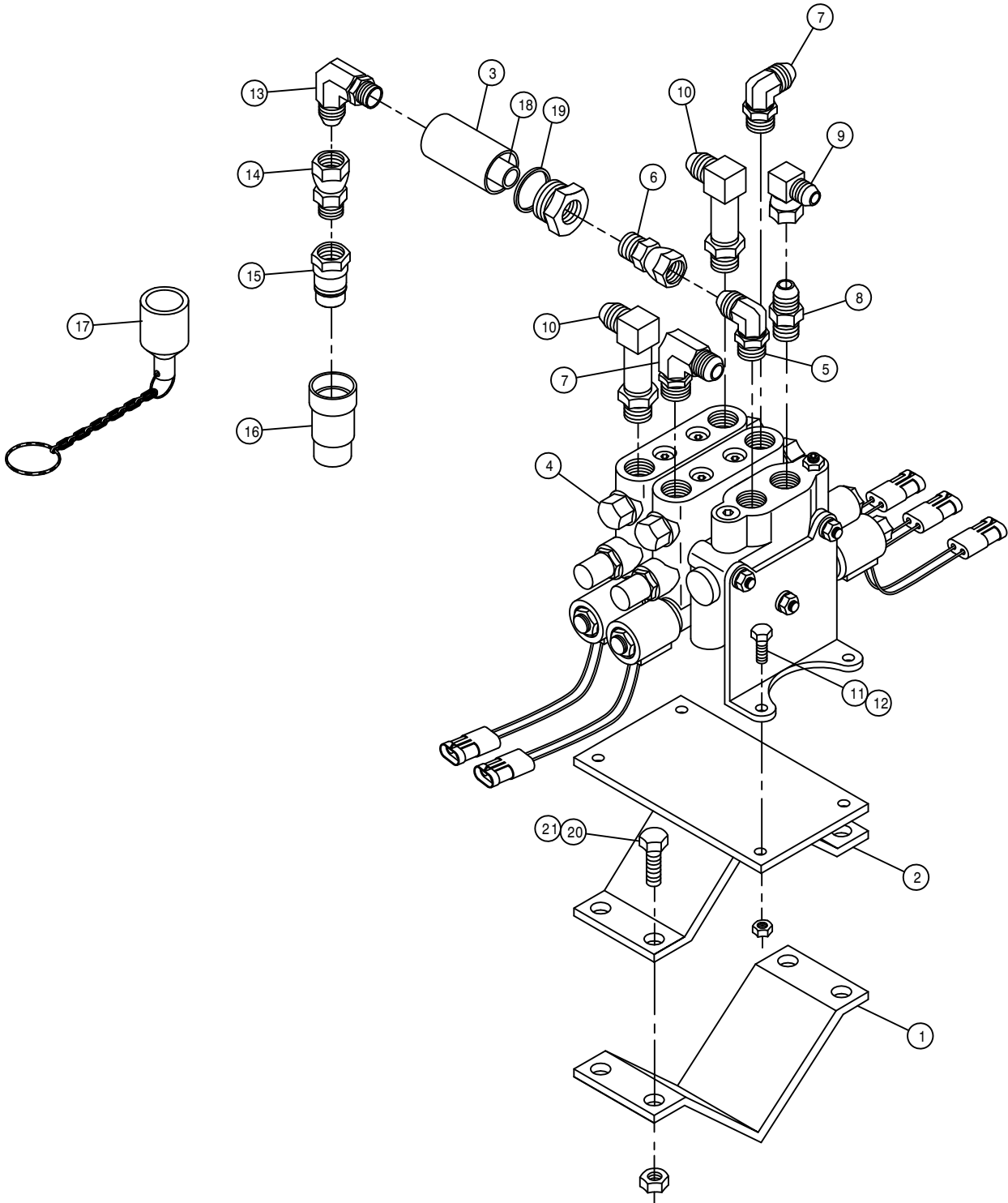

OUTRIGGER FOLD VALVE ASSEMBLY

DET. QTY PART NO. DESCRIPTION

1	1	438324	75IN OUTRGR BRACE CLAMP
2	1	438724	OUTRGR FOLD VLV MT WLD2100/STS
3	1	605610	HYD FILTER, INLINE 90M 3/4FOR
4	1	606090	BRAND HYD VALVE, 2-SECT SER 36
5	1	618183	3/4MJIC-90-7/8MOR LBO
6	1	618669	3/4FJIC SWIV-3/4MOR ADPTR
7	2	618115	9/16MJIC-90-3/4MOR LBO
8	1	618310	9/16MJIC-7/8MOR ADPTR
9	1	618618	9/16MJIC-90-9/16FJIC SWIV LBO
10	2	618709	9/16MJIC-90-3/4MOR EX LG LBO
11	4	900065	5/16UNC X 1" HEX BOLT
12	4	914002	5/16UNC HEX STOVER NUT
13	1	618241	3/4MJIC-90-3/4MOR LBO
14	1	618623	3/4FJIC-SWIV-1/2MNPT
15	1	618622	HYD QUICK CPLR, MALE, .50FNPS
16	1	618621	HYD QUICK CPLR,FEMALE, .50FNPS
17	1	618636	RUBBER DUST CAP FOR 618622
18	1	610459	90M FILTER & GASKET FOR610447
19	1	610462	GASKET FOR 610447 ARROW FILT
20	4	900265	1/2UNC X 1 1/2 HEX BOLT
21	4	914008	1/2UNC HEX STOVER NUT

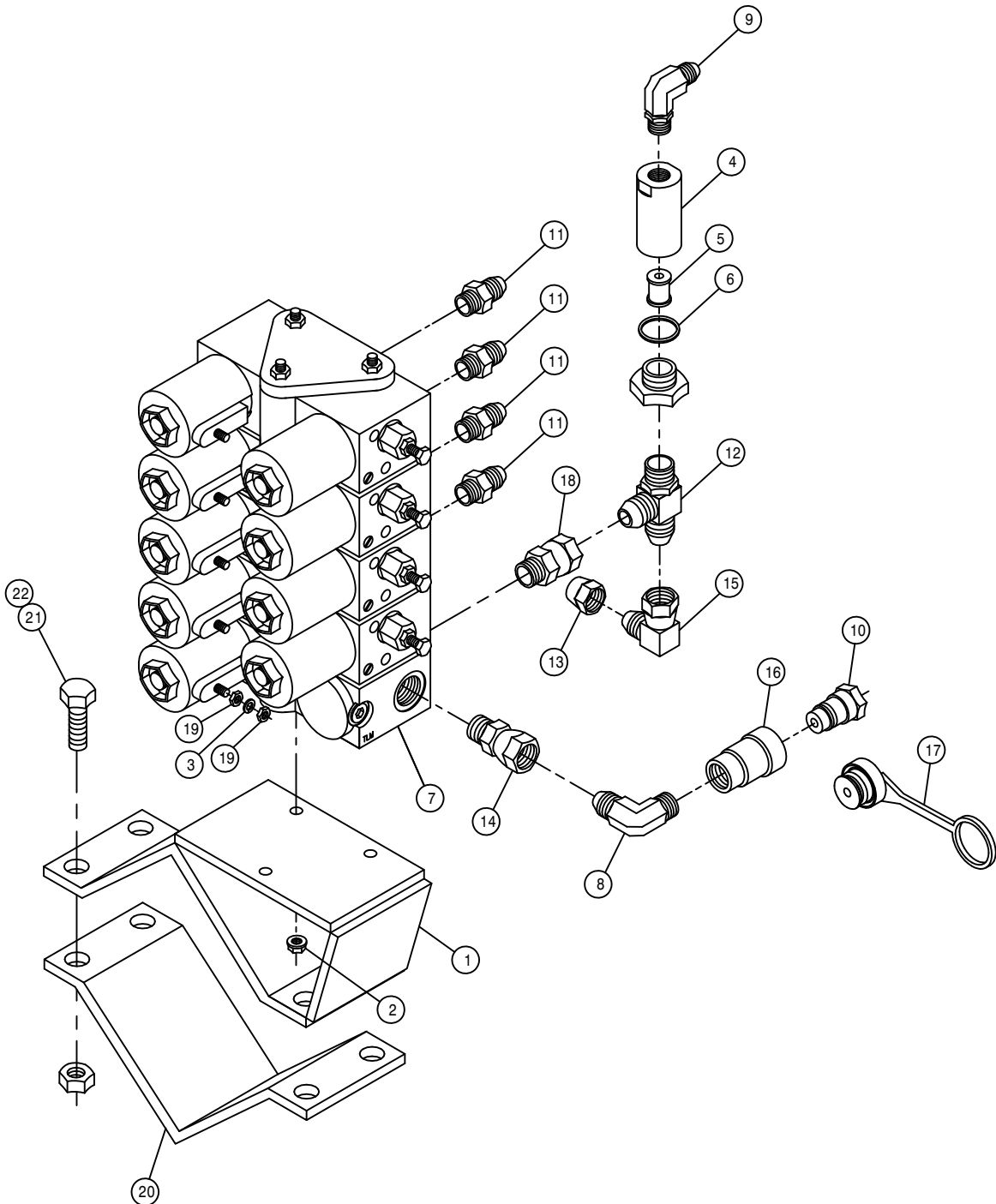

4-LIFT ELECTRIC VALVE ASSEMBLY

DET.	QTY	PART NO.	DESCRIPTION
1	1	438614	ELECT VLV MT WLD, 2100 COMBO
2	3	470121	1/4UNC HEX FLANGE LOCK NUT
3	9	473821	#10 INT TOOTH WASHER
4	1	605610	HYD FILTER, INLINE 90M 3/4FOR
5	1	610459	90M FILTER & GASKET FOR610447
6	1	610462	GASKET FOR 610447 ARROW FILT
7	1	610613	ELECT HYD STACT VLV, 4 SECT
8	1	611124	7/8MJIC-90-1/2MNPT LBO
9	1	618115	9/16MJIC-90-3/4MOR LBO
10	1	618622	HYD QUICK CPLR, MALE, .50FNPS
11	4	618126	9/16MJIC-9/16MOR ADPTR
12	1	618494	3/4MOR RUN TEE-3/4MJIC
13	1	618532	3/4FJIC CAP NUT
14	1	618594	7/8FJIC SWIV-7/8MOR ADPTR
15	1	618609	3/4MJIC-90-3/4FJIC SWIV LBO
16	1	618621	HYD QUICK CPLR, FEMALE, .50FNPS
17	1	618635	RUBBER DUST PLUG FOR 618621
18	1	618669	3/4FJIC SWIV-3/4MOR ADPTR
19	18	910027	10-32 HEX NUT
20	1	438324	75IN OUTRGR BRACE CLAMP
21	4	900265	1/2UNC X 1 1/2 HEX BOLT
22	4	914008	1/2UNC HEX STOVER NUT

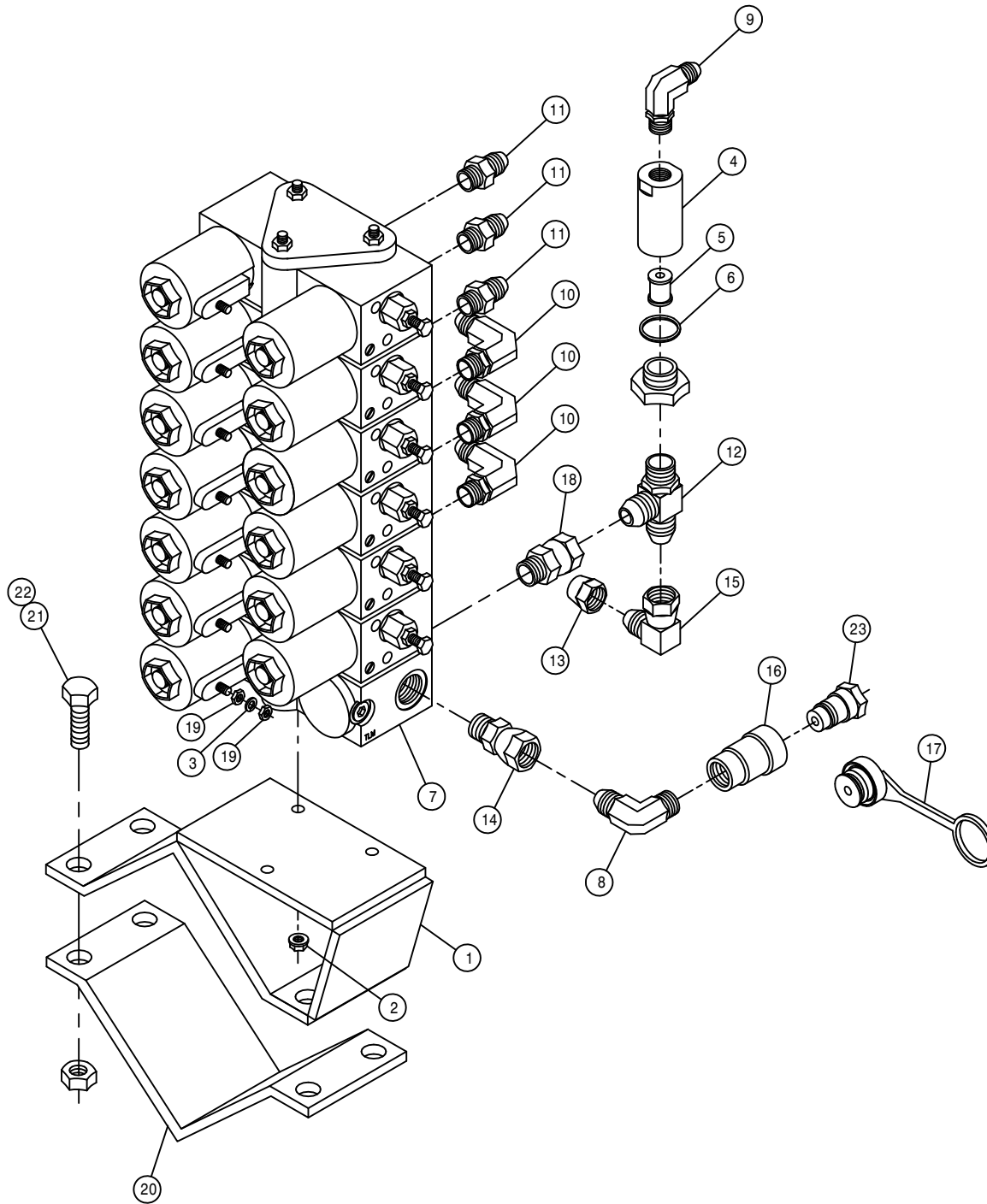

6-LIFT ELECTRIC VALVE ASSEMBLY

DET. QTY PART NO. DESCRIPTION

DET.	QTY	PART NO.	DESCRIPTION
1	1	438614	ELECT VLV MT WLD, 2100 COMBO
2	3	470121	1/4UNC HEX FLANGE LOCK NUT
3	13	473821	#10 INT TOOTH WASHER
4	1	605610	HYD FILTER, INLINE 90M 3/4FOR
5	1	610459	90M FILTER & GASKET FOR610447
6	1	610462	GASKET FOR 610447 ARROW FILT
7	1	610615	ELECT HYD STACT VLV, 6 SECT
8	1	611124	7/8MJIC-90-1/2MNPT LBO
9	1	618115	9/16MJIC-90-3/4MOR LBO
10	3	618119	9/16MJIC-90-9/16MOR LBO
11	3	618126	9/16MJIC-9/16MOR ADPTR
12	1	618494	3/4MOR RUN TEE-3/4MJIC
13	1	618532	3/4FJIC CAP NUT
14	1	618594	7/8FJIC SWIV-7/8MOR ADPTR
15	1	618609	3/4MJIC-90-3/4FJIC SWIV LBO
16	1	618621	HYD QUICK CPLR,FEMALE, .50FNPS
17	1	618635	RUBBER DUST PLUG FOR 618621
18	1	618669	3/4FJIC SWIV-3/4MOR ADPTR
19	26	910027	10-32 HEX NUT
20	1	438324	75IN OUTGR BRACE CLAMP
21	4	900265	1/2UNC X 1 1/2 HEX BOLT
22	4	914008	1/2UNC HEX STOVER NUT
23	1	618622	HYD QUICK CPLR, MALE, .50FNPS

129

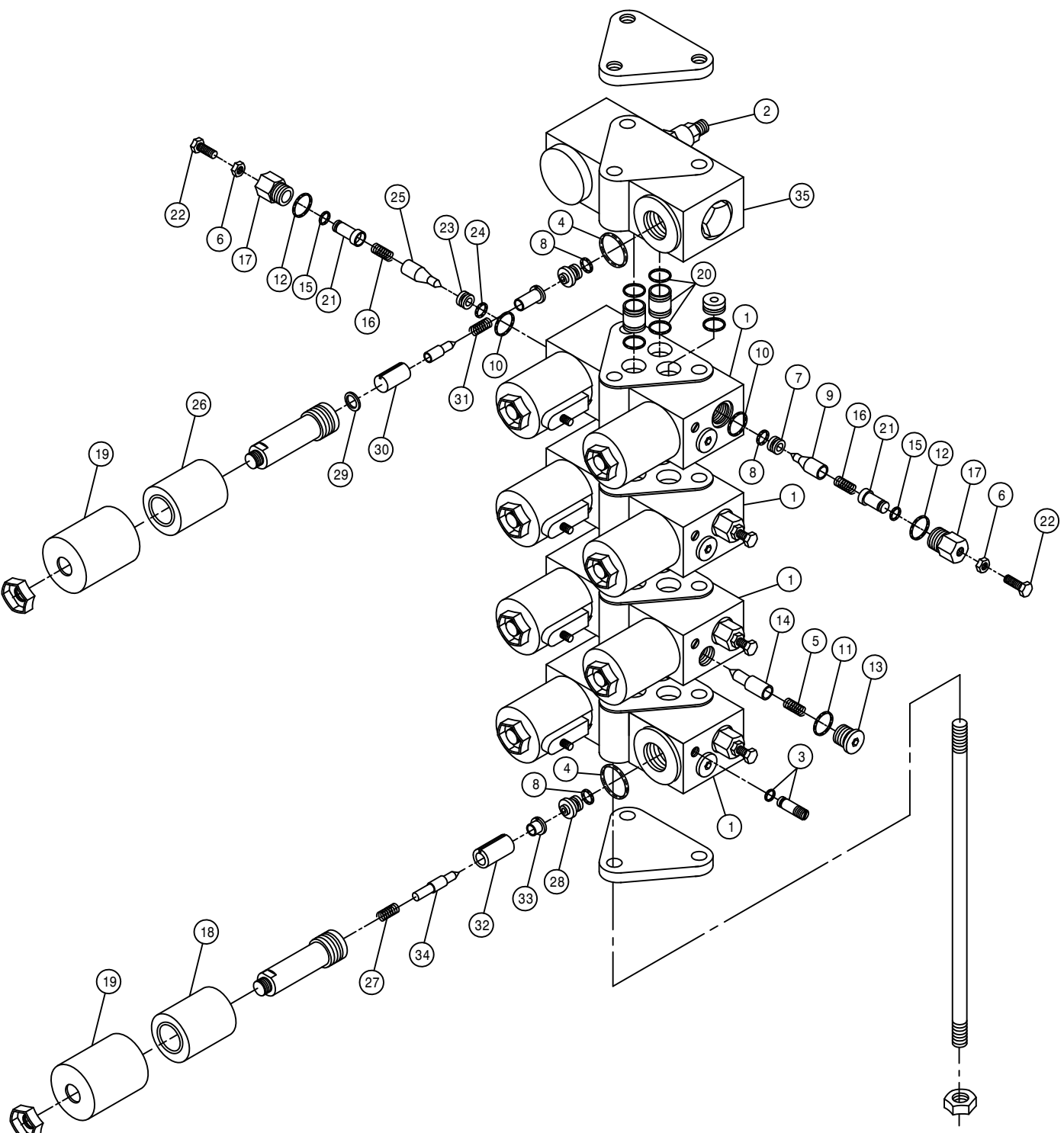

ELECTROHYDRAULIC VALVE

DET.	QTY	PART NO.	DESCRIPTION	
1	4	610533	UNBALANCED LOAD VALVE	89
2	1	610551	R.V. CARTRIDGE FOR 610532	90
3	8	610267	SEAL PLUG ASSY FOR 610257	
4	9	871019	ORING, 13/16 X 15/16 NEO 90D	
5	4	610491	SPRING AM-501-3-035 FOR610485	
6	8	910000	1/4UNC HEX NUT	
7	4	610488	ORIFICE PRESSED IN BLACK	
8	13	871010	ORING 1/4 X 3/8 VITON 90D	
9	4	610129	POPPET,ELECT VALVE,UNBAL LOAD	
10	8	870013	ORING, 7/16 X 9/16 NEO 70D	
11	4	871904	ORING, .351 X .072CS NEO 90D	
12	8	871906	ORING, .468ID X .078CS NEO 90D	
13	4	610130	PLUG, SAE4,ELECT VALVE,UNBAL	
14	4	610489	CHECK VLV POPPET	
15	8	871008	O-RING 3/16 X 5/16 90D	
16	8	610492	SPRING AM-570-3-126 FOR610485	
17	8	610453	VLV CAP	
18	8	610493	COIL FOR 610485	86
19	9	610113	COVER, ELECT VALVE, NON ADJ	
20	8	610534	THRU TUBE ASSY ELEC VLV	89
21	8	610452	ADJ VLV STOP	
22	8	900003	1/4UNC X 1" HEX BOLT	
23	4	610494	ORIFICE FOR 610485	
24	4	871056	O-RING	90D
25	4	610495	POPPET FOR 610485AM-570-3-654	
26	1	610076	COIL, ELECT STACK VALVE	
27	8	610127	SPRING,ELECT VALVE,UNBAL LOAD	
28	8	610108	ORIFICE 040, ELECT VALVE	
29	1	610084	WASHER, ELECT-HYD VALVE	
30	1	610112	ARMATURE, ELECT VALVE	
31	1	610110	SPRING, ELECT VALVE, NON ADJ	
32	8	610126	ARMATURE, ELECT VALVE, UNBAL	
33	8	610133	POLE PIECE,ELECT VALVE, UNBAL	
34	8	610490	POPPET FOR 610485AM-501-3-033	
35	1	610679	UNLOAD RELIEF VALVE	

250129

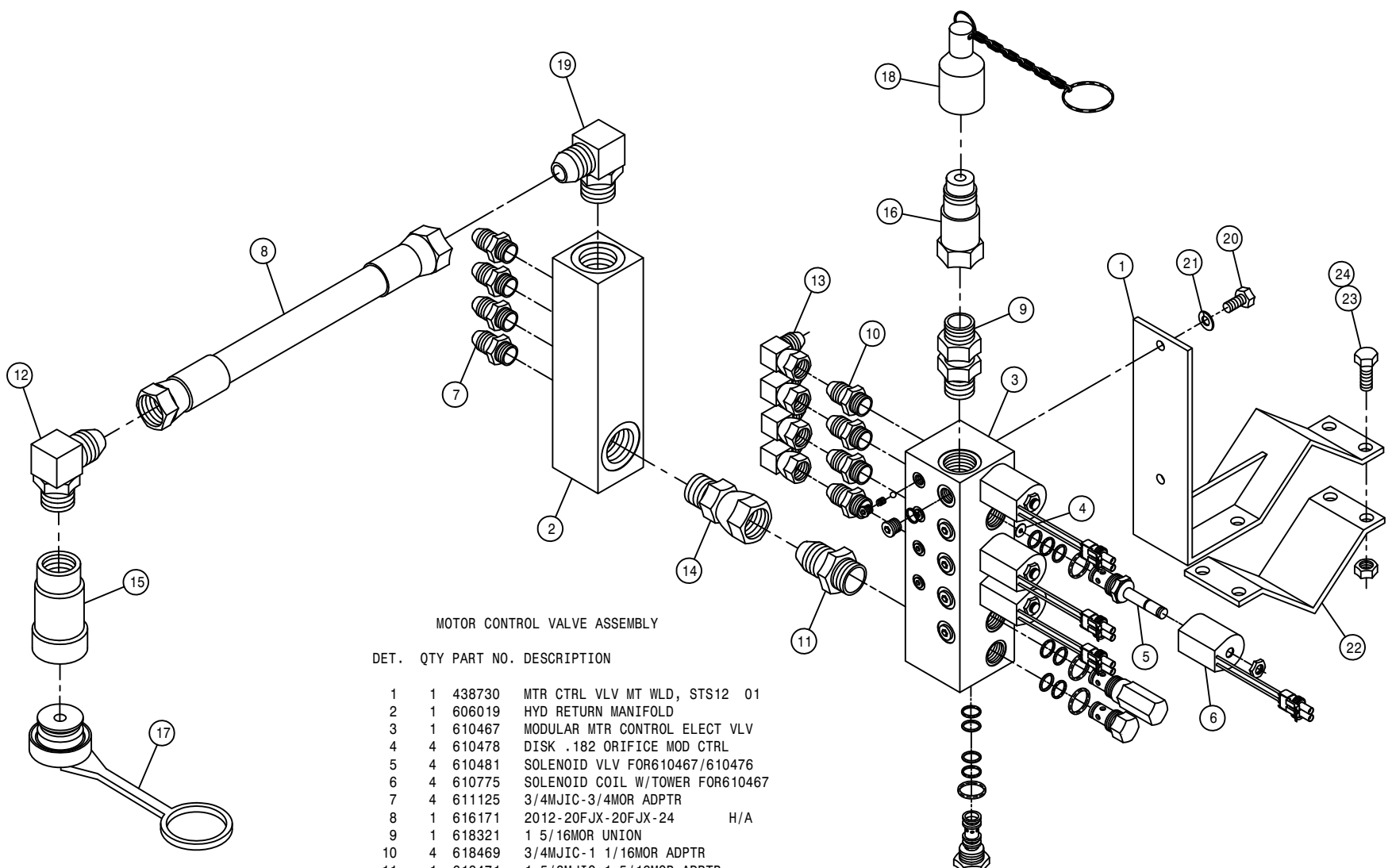

MOTOR CONTROL VALVE ASSEMBLY

DET.	QTY	PART NO.	DESCRIPTION
	1	438730	MTR CTRL VLV MT WLD, STS12 01
	1	606019	HYD RETURN MANIFOLD
	1	610467	MODULAR MTR CONTROL ELECT VLV
	4	610478	DISK .182 ORIFICE MOD CTRL
	4	610481	SOLENOID VLV FOR610467/610476
	4	610775	SOLENOID COIL W/TOWER FOR610467
	4	611125	3/4MJIC-3/4MOR ADPTR
	1	616171	2012-20FJX-20FJX-24 H/A
	1	618321	1 5/16MOR UNION
	4	618469	3/4MJIC-1 1/16MOR ADPTR
	1	618471	1 5/8MJIC-1 5/16MOR ADPTR
	1	618476	1 5/8MJIC-90-1 5/16MOR LBO
	4	618609	3/4MJIC-90-3/4FJIC SWIV LBO
	1	618683	1 5/8MOR-1 5/8FJIC SWIV ADPTR
	1	618686	HYD QUICK CPLR, FEMALE 1.00UNF
	1	618687	HYD QUICK CPLR, MALE 1.00UNF
	1	618690	DUST PLUG FOR COUPLER 618686
	1	618691	DUST CAP FOR COUPLER 618687
	1	618704	1 5/8MJIC-90-1 7/8MOR LBO
	2	900128	3/8UNC X 3/4 HEX BOLT
	2	920502	3/8 LOCK WASHER
	1	438324	75IN OUTRGR BRACE CLAMP
	4	900265	1/2UNC X 1 1/2 HEX BOLT
	4	914008	1/2UNC HEX STOVER NUT

8-10 ROW 4-LIFT COMBO OUTRIGGER ASSEMBLY

DET. QTY PART NO. DESCRIPTION

DET.	QTY	PART NO.	DESCRIPTION
1	1	438707	RH 75IN OUTGR WLD 2100-ST512
2	1	438708	LH 75IN OUTGR WLD 2100-ST512
3	12	438324	75IN OUTGR BRACE CLAMP
4	1	438695	TOOLBAR WLD, 2100-ST512 COMBO
5	2	438718	OUTGR CYL MT WLD, STS12 COMBO
6	2	621014	OUTGR FOLD CYL ASSY, 2100COMBO
7	2	438283	OUTGR PIVOT PIN WLD 8200 86
8	2	470117	COTTER PIN 3/16 1 3/4 SQ CUT
9	48	900265	1/2UNC X 1 1/2 HEX BOLT
10	52	914008	1/2UNC HEX STOVER NUT
11	2	900338	5/8UNC X 3" HEX BOLT
12	2	900343	5/8UNC X 4 1/2 HEX BOLT
13	12	914010	5/8UNC HEX STOVER NUT
14	2	438362	RH OUTGR CLAMP WLD 200 89
15	2	438363	LH OUTGR CLAMP WLD 200 89
16	1	438709	RH 101IN OUTGR WLD 2100-ST512
17	1	438710	LH 101IN OUTGR WLD 2100-ST512
18	2	438664	OUTGR TIE BAR WLD 72"2100/STS
19	2	438544	OUTGR SUPP ROD WLD 50"10/12R
20	1	438595	RH OUTGR SUPP POST WLD284C 97
21	1	438596	LH OUTGR SUPP POST WLD284C 97
22	2	438609	OUTGR SUPP BRACE, 2100 COMBO
23	2	438541	BUSH, 1.00 OD X .656ID X .53
24	2	483037	5/8 REGULAR FLAT WASHER
25	4	900271	1/2UNC X 3 1/4 HEX BOLT
26	6	900333	5/8UNC X 1 1/2 HEX BOLT
27	2	900352	5/8UNC X 2 1/4 HEX BOLT
28	12	910012	3/4UNC HEX NUT
29	6	438397	STABILIZER PIN MT WLD 90
30	1	438682	RH TOOL BAR ADPTR WLD, STS12C
31	1	438683	LH TOOL BAR ADPTR WLD, STS12C
32	2	438715	TOOLBAR SUPP ROD WLD, STS12C
33	2	438721	RATCHET JACK EXTN WLD, STS12C
34	2	438657	RATCHET JACK WLD
35	6	611016	HAIR PIN #6
36	4	472206	PICKER PIN 1 DIA X 2 1/4
37	2	438700	TOOLBAR STOP SHIM, 16GA (.060)
38	4	438701	TOOLBAR STOP SHIM, 14GA (.075)
39	4	438702	TOOLBAR STOP SHIM, 11GA (.120)
40	2	438703	TOOLBAR STOP, 2100-ST512 COMBO
41	4	900130	3/8UNC X 1 1/4 HEX BOLT
42	4	920002	3/8 SAE FLAT WASHER
43	4	920502	3/8 LOCK WASHER
44	2	438723	RATCHET JACK CLEVIS, STS12COMBO
45	2	900401	3/4UNC X 1 1/2 HEX BOLT
46	12	900403	3/4UNC X 2" HEX BOLT
47	14	914012	3/4UNC HEX STOVER NUT

NOTE: QUANTITY LISTED IS FOR ONE MACHINE.

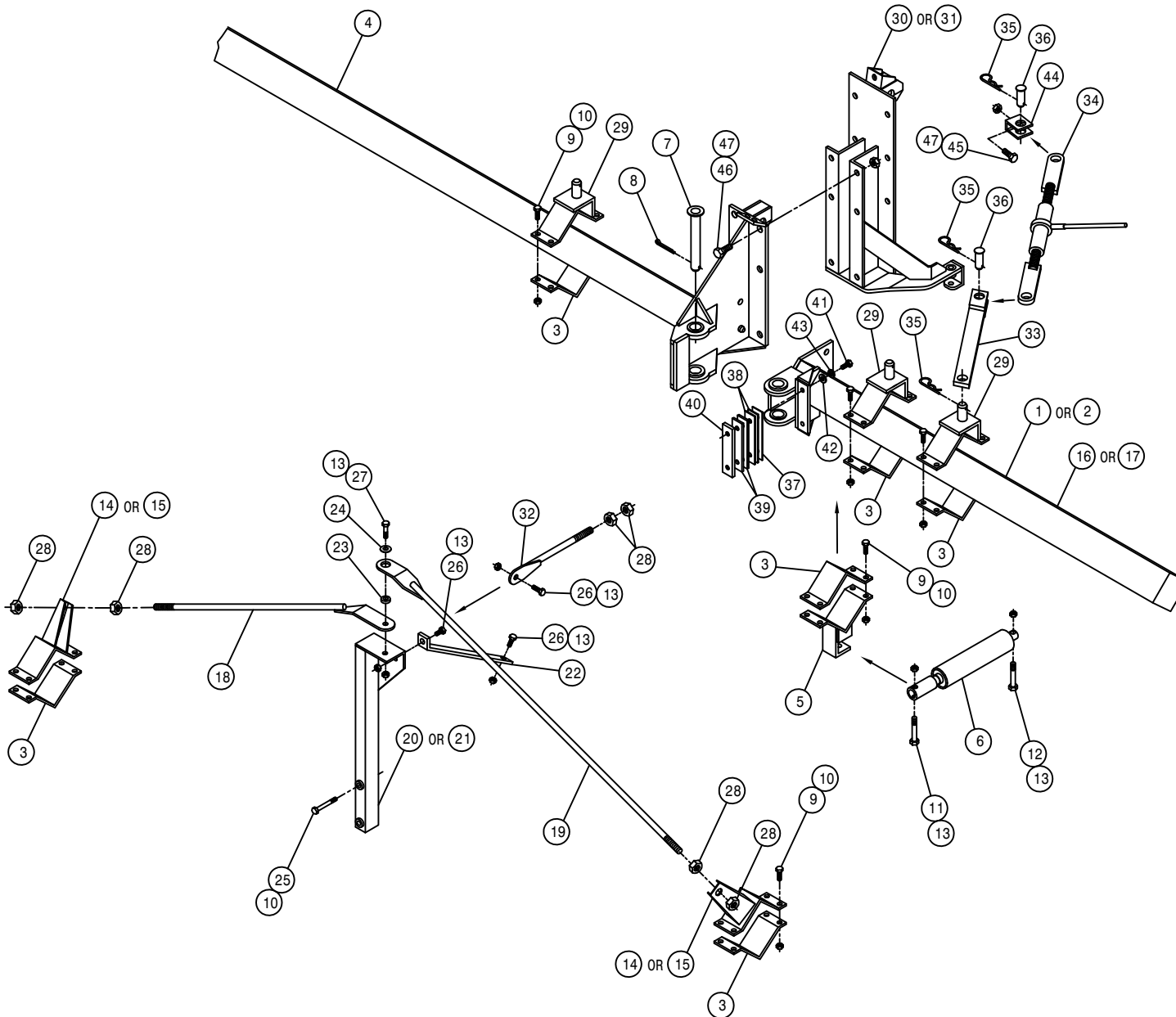

12 ROW 6-LIFT COMBO OUTRIGGER ASSEMBLY

DET. QTY PART NO. DESCRIPTION

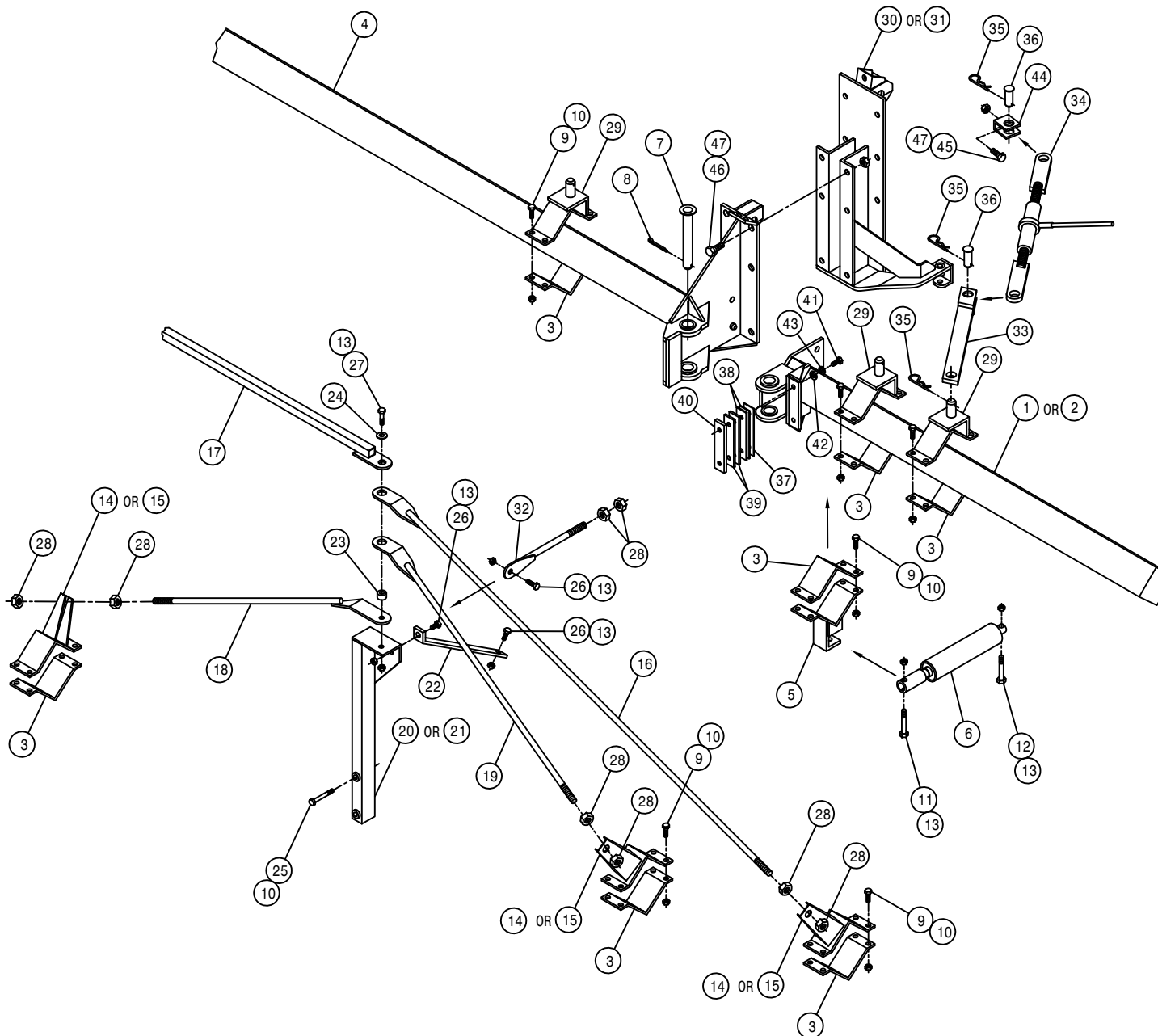

1	1	438711	RH 133IN OUTRGR WLD 2100-ST512
2	1	438712	LH 133IN OUTRGR WLD 2100-ST512
3	14	438324	75IN OUTRGR BRACE CLAMP
4	1	438695	TOOLBAR WLD, 2100-ST512 COMBO
5	2	438718	OUTRGR CYL MT WLD, STS12 COMBO
6	2	621014	OUTRGR FOLD CYL ASSY,2100COMBO
7	2	438283	OUTRGR PIVOT PIN WLD 8200 86
8	2	470117	COTTER PIN 3/16 1 3/4 SQ CUT
9	56	900265	1/2UNC X 1 1/2 HEX BOLT
10	60	914008	1/2UNC HEX STOVER NUT
11	2	900338	5/8UNC X 3" HEX BOLT
12	2	900343	5/8UNC X 4 1/2 HEX BOLT
13	12	914010	5/8UNC HEX STOVER NUT
14	3	438362	RH OUTRGR CLAMP WLD 200 89
15	3	438363	LH OUTRGR CLAMP WLD 200 89
16	2	438471	OUTRGR SUPP ROD WLD 10-12R
17	1	438547	204 TIE TUBE WLD, 10/12R 96
18	2	438664	OUTRGR TIE BAR WLD 72"2100/STS
19	2	438544	OUTRGR SUPP ROD WLD 50"10/12R
20	1	438595	RH OUTRGR SUPP POST WLD284C 97
21	1	438596	LH OUTRGR SUPP POST WLD284C 97
22	2	438609	OUTRGR SUPP BRACE, 2100 COMBO
23	2	438541	BUSH, 1.00 OD X .65ID X .53
24	2	483037	5/8 REGULAR FLAT WASHER
25	4	900271	1/2UNC X 3 1/4 HEX BOLT
26	6	900333	5/8UNC X 1 1/2 HEX BOLT
27	2	900352	5/8UNC X 2 1/4 HEX BOLT
28	16	910012	3/4UNC HEX NUT
29	6	438397	STABILIZER PIN MT WLD 90
30	1	438682	RH TOOL BAR ADPTR WLD, STS12C
31	1	438683	LH TOOL BAR ADPTR WLD, STS12C
32	2	438715	TOOLBAR SUPP ROD WLD, STS12C
33	2	438721	RATCHET JACK EXTN WLD, STS12C
34	2	438657	RATCHET JACK WLD
35	6	611016	HAIR PIN #6
36	4	472206	PICKER PIN 1 DIA X 2 1/4
37	2	438700	TOOLBAR STOP SHIM, 16GA (.060)
38	4	438701	TOOLBAR STOP SHIM, 14GA (.075)
39	4	438702	TOOLBAR STOP SHIM, 11GA (.120)
40	2	438703	TOOLBAR STOP, 2100-ST512 COMBO
41	4	900130	3/8UNC X 1 1/4 HEX BOLT
42	4	920002	3/8 SAE FLAT WASHER
43	4	920502	3/8 LOCK WASHER
44	2	438723	RATCHET JACK CLEVIS, STS12COMBO
45	2	900401	3/4UNC X 1 1/2 HEX BOLT
46	12	900403	3/4UNC X 2" HEX BOLT
47	14	914012	3/4UNC HEX STOVER NUT

NOTE: QUANTITY LISTED IS FOR ONE MACHINE.

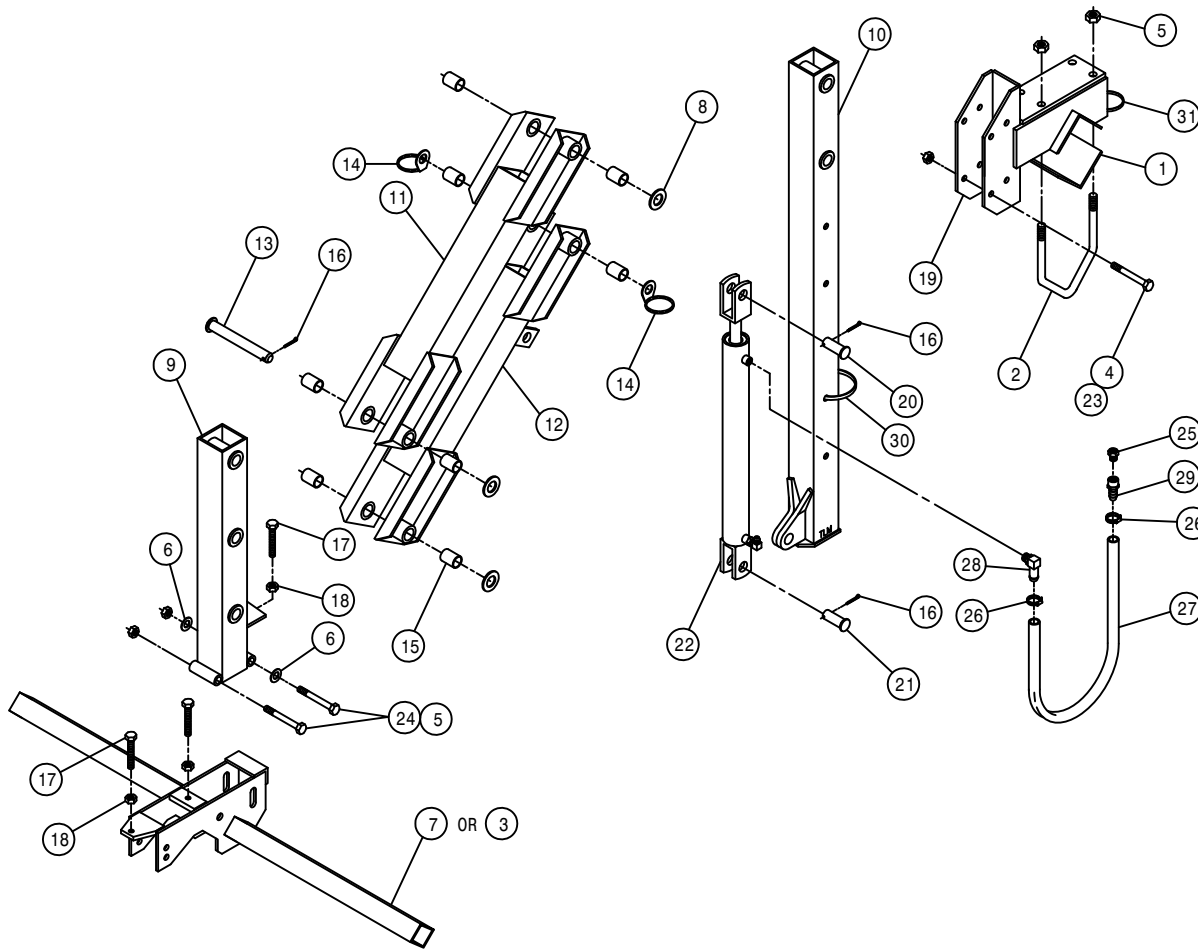

COMBO DETASSELER LIFT ASSEMBLY

DET.	QTY	PART NO.	DESCRIPTION
1	1	438292	TOOL BAR V-PLT WLD 8200 86
2	2	438293	5/8UNC X 6 1/4 CTR U-BOLT TRI
3	1	438478	TOOL BAR WLD 10-12R DETASSLR
4	4	914008	1/2UNC HEX STOVER NUT
5	6	914010	5/8UNC HEX STOVER NUT
6	2	920005	5/8 SAE FLAT WASHER
7	1	438194	TOOL BAR WLD DETAS 4-6R 83
8	3	920008	1" SAE FLAT WASHER
9	1	438245	TOOL BAR MT WLD,2-POS DETAS
10	1	438184	HOIST COL WLD DETAS LIFT 83
11	1	438294	UPPER LIFT ARM WLD 8200 86
12	1	438297	LWR LIFT ARM WLD 8200 86
13	4	438300	LIFT ARM PIVOT PIN WLD8200 86
14	2	438302	HOSE SUPPORT RING WLD
15	8	121025	JOURNAL BRG, 1.00 ID X 1.50 LG
16	6	470162	COTTER PIN 3/16 X 1 1/2 SQCUT
17	2	900538	1/2UNC X 3 1/2 HEX BOLT FULL
18	2	910008	1/2UNC HEX NUT
19	1	438367	HOIST COL MT BRKT WLD 200 90
20	1	472012	CLEVIS PIN, 1.00 X 3.25 PLT
21	1	472206	PICKER PIN 1 DIA X 2 1/4
22	1	621010	LIFT CYL ASSY, DETASSELER
23	4	900275	1/2UNC X 4 1/2 HEX BOLT
24	2	900343	5/8UNC X 4 1/2 HEX BOLT
25	1	470114	BREATHER FILTER VENT, 1/4 NPT
26	2	520120	HOSE CLAMP NO 4 STAINLESS
27	1	601420	HOSE, 3/8 X 48 CLEAR VINYL
28	1	618343	3/8 HOSE BARB-90-9/16MOR
29	1	783306	1/4 FNPT X 3/8 HOSE BARB, BRS
30	1	470000	CABLE TIE, 21" BLACK PLASTIC
31	1	470154	CABLE TIE, 11.75" BLK PLASTIC

134

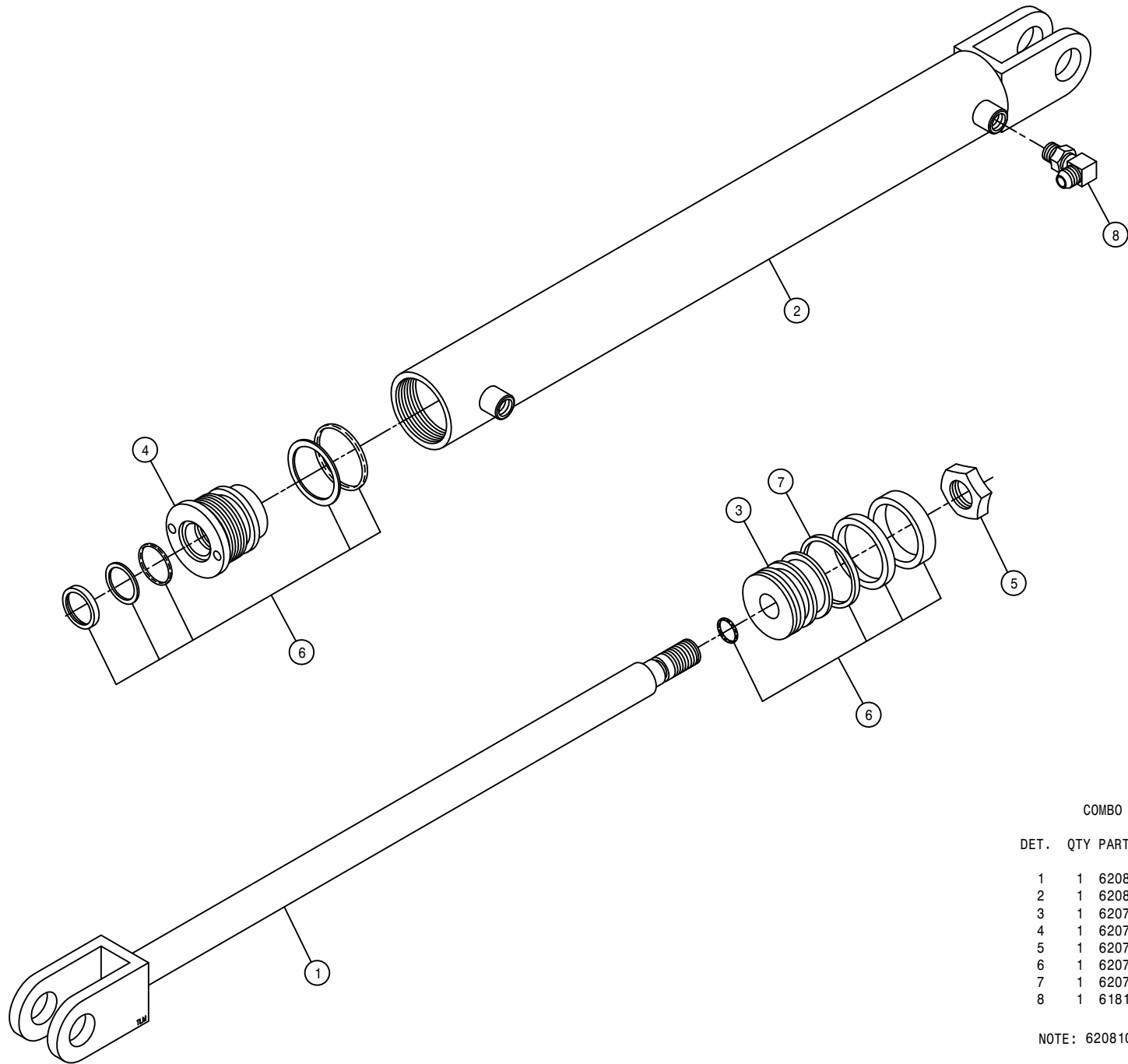

COMBO LIFT CYLINDER ASSEMBLY

DET.	QTY	PART NO.	DESCRIPTION
	1	620813	SHAFT, LIFT CYL, DETASS 620810
	1	620814	BARREL, LIFT CYL, DETASS 620810
	1	620754	PISTON, P-2.00-120
	1	620758	HEAD, H-2.00-345
	1	620757	NUT, N-0.75-02
	1	620778	REPAIR KIT, HYD CYL, RK-2.00-800
	1	620753	STEEL PISTON RING, R-2.00-01
	1	618119	9/16MJIC-90-9/16MOR LBO

NOTE: 620810 - LIFT CYLINDER INCLUDES ITEMS 1-7.

250134

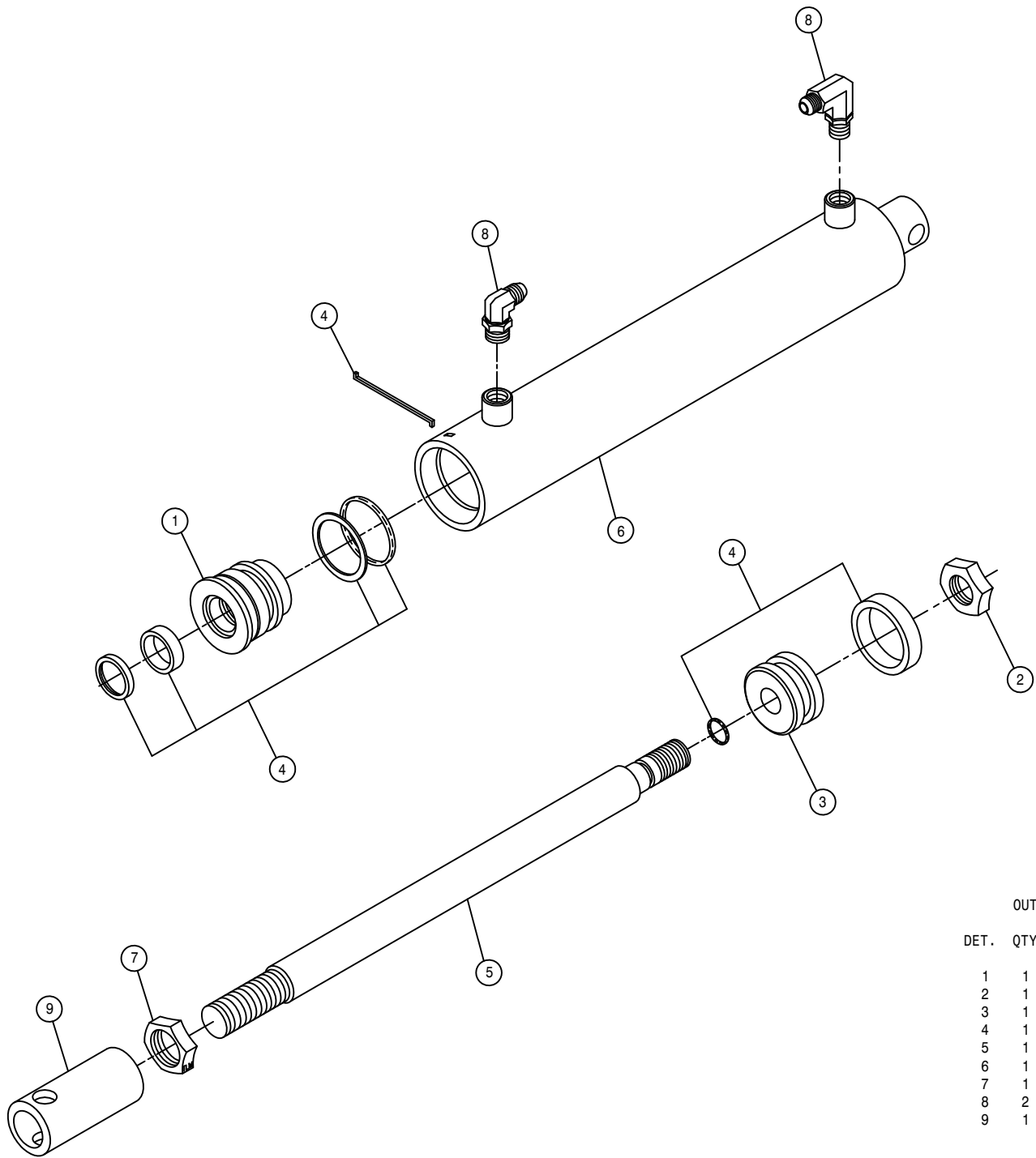

OUTRIGGER FOLD CYLINDER ASSEMBLY

DET.	QTY	PART NO.	DESCRIPTION
	1	620744	HEAD, H-2.00-033
	1	620759	NUT, N-0.75-01
	1	620760	PISTON, P-2.00-008
	1	620780	REPAIR KIT, HYD CYL, RK-2.00-806
	1	620848	SHAFT, BOOM FOLD CYL 620845
	1	620849	BARREL, BOOM FOLD CYL 620845
	1	472322	7/8UNF HEX JAM NUT
	2	614747	.025 ELBOW ASSY, 9/16MOR 90D
	1	620653	FOLD CYL ADJ SLEEVE 97

NOTE: 1. 620845 - OUTRIGGER FOLD CYLINDER ASSEMBLY 1-6
 2. 621014 - OUTRIGGER FOLD CYLINDER ASSEMBLY WITH FITTINGS

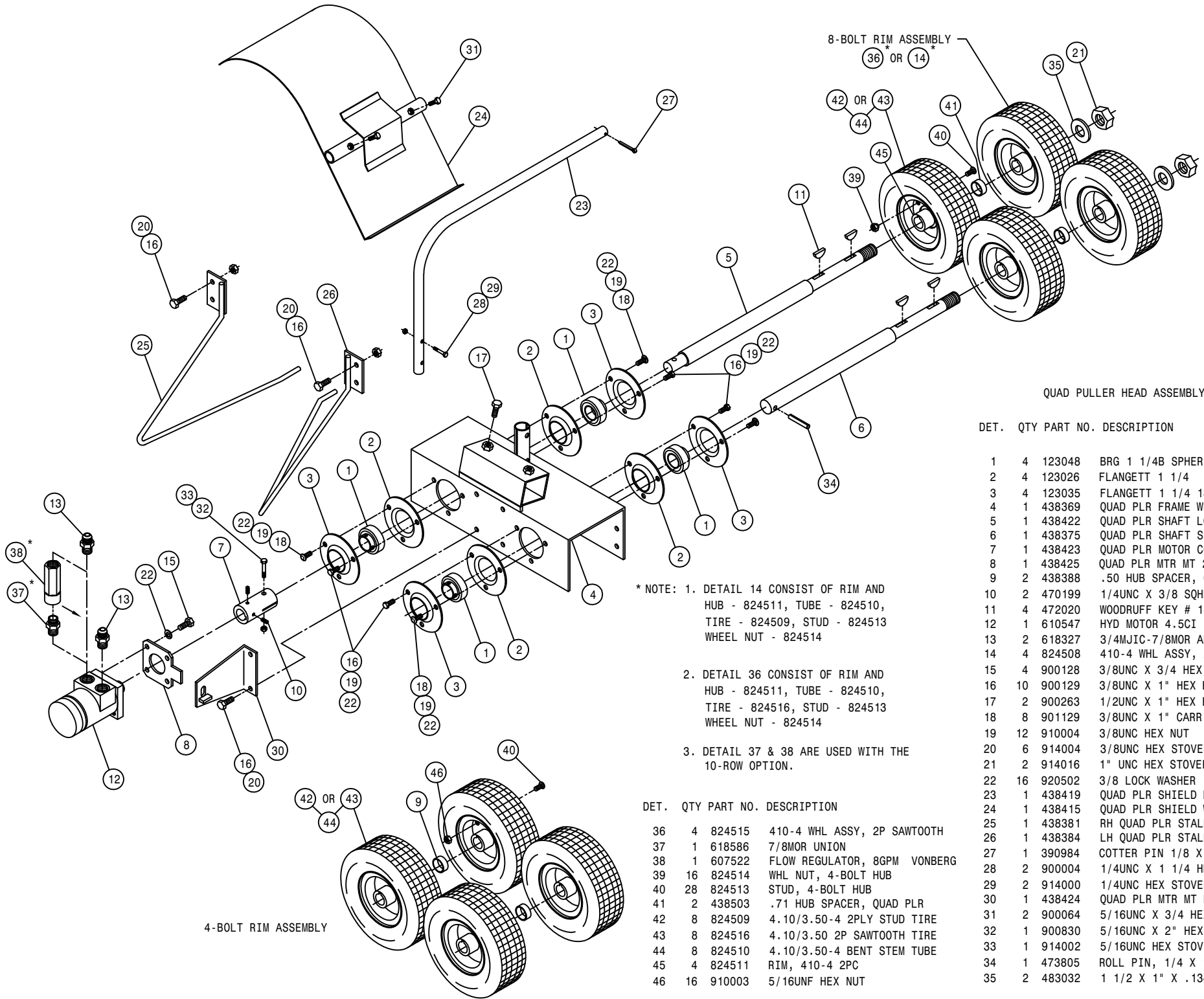

QUAD PULLER HEAD ASSEMBLY

DET.	QTY	PART NO.	DESCRIPTION
1	4	123048	BRG 1 1/4B SPHER RELUB SCRLOC
2	4	123026	FLANGETT 1 1/4
3	4	123035	FLANGETT 1 1/4 180 DEG ZERK
4	1	438369	QUAD PLR FRAME WLD 200 90
5	1	438422	QUAD PLR SHAFT LONG 200 91
6	1	438375	QUAD PLR SHAFT SHORT 200 90
7	1	438423	QUAD PLR MOTOR COUPLER 200 91
8	1	438425	QUAD PLR MTR MT 200 91
9	2	438388	.50 HUB SPACER, QUAD PLR
10	2	470199	1/4UNC X 3/8 SQHD CUP SET SCR
11	4	472020	WOODRUFF KEY # 18 1/4 X 1 1/8
12	1	610547	HYD MOTOR 4.5CI 1IN SHFT
13	2	618327	3/4MJIC-7/8MOR ADPTR
14	4	824508	410-4 WHL ASSY, 2P STUD
15	4	900128	3/8UNC X 3/4 HEX BOLT
16	10	900129	3/8UNC X 1" HEX BOLT
17	2	900263	1/2UNC X 1" HEX BOLT
18	8	901129	3/8UNC X 1" CARR BOLT
19	12	910004	3/8UNC HEX NUT
20	6	914004	3/8UNC HEX STOVER NUT
21	2	914016	1" UNC HEX STOVER NUT
22	16	920502	3/8 LOCK WASHER
23	1	438419	QUAD PLR SHIELD MT TUBE 91
24	1	438415	QUAD PLR SHIELD WLD 200 91
25	1	438381	RH QUAD PLR STALK GUIDE WLD90
26	1	438384	LH QUAD PLR STALK GUIDE WLD90
27	1	390984	COTTER PIN 1/8 X 1 1/4
28	2	900004	1/4UNC X 1 1/4 HEX BOLT
29	2	914000	1/4UNC HEX STOVER NUT
30	1	438424	QUAD PLR MTR MT PLT WLD
31	2	900064	5/16UNC X 3/4 HEX BOLT
32	1	900830	5/16UNC X 2" HEX BOLT GR8
33	1	914002	5/16UNC HEX STOVER NUT
34	1	473805	ROLL PIN, 1/4 X 1 1/2
35	2	483032	1 1/2 X 1" X .134TH MACH WASH

* NOTE: 1. DETAIL 14 CONSIST OF RIM AND HUB - 824511, TUBE - 824510, TIRE - 824509, STUD - 824513 WHEEL NUT - 824514

2. DETAIL 36 CONSIST OF RIM AND HUB - 824511, TUBE - 824510, TIRE - 824516, STUD - 824513 WHEEL NUT - 824514

3. DETAIL 37 & 38 ARE USED WITH THE 10-ROW OPTION.

DET.	QTY	PART NO.	DESCRIPTION
36	4	824515	410-4 WHL ASSY, 2P SAWTOOTH
37	1	618586	7/8MOR UNION
38	1	607522	FLOW REGULATOR, 8GPM VONBERG
39	16	824514	WHL NUT, 4-BOLT HUB
40	28	824513	STUD, 4-BOLT HUB
41	2	438503	.71 HUB SPACER, QUAD PLR
42	8	824509	4.10/3.50-4 2PLY STUD TIRE
43	8	824516	4.10/3.50 2P SAWTOOTH TIRE
44	8	824510	4.10/3.50-4 BENT STEM TUBE
45	4	824511	RIM, 410-4 2PC
46	16	910003	5/16UNF HEX NUT

4-BOLT RIM ASSEMBLY

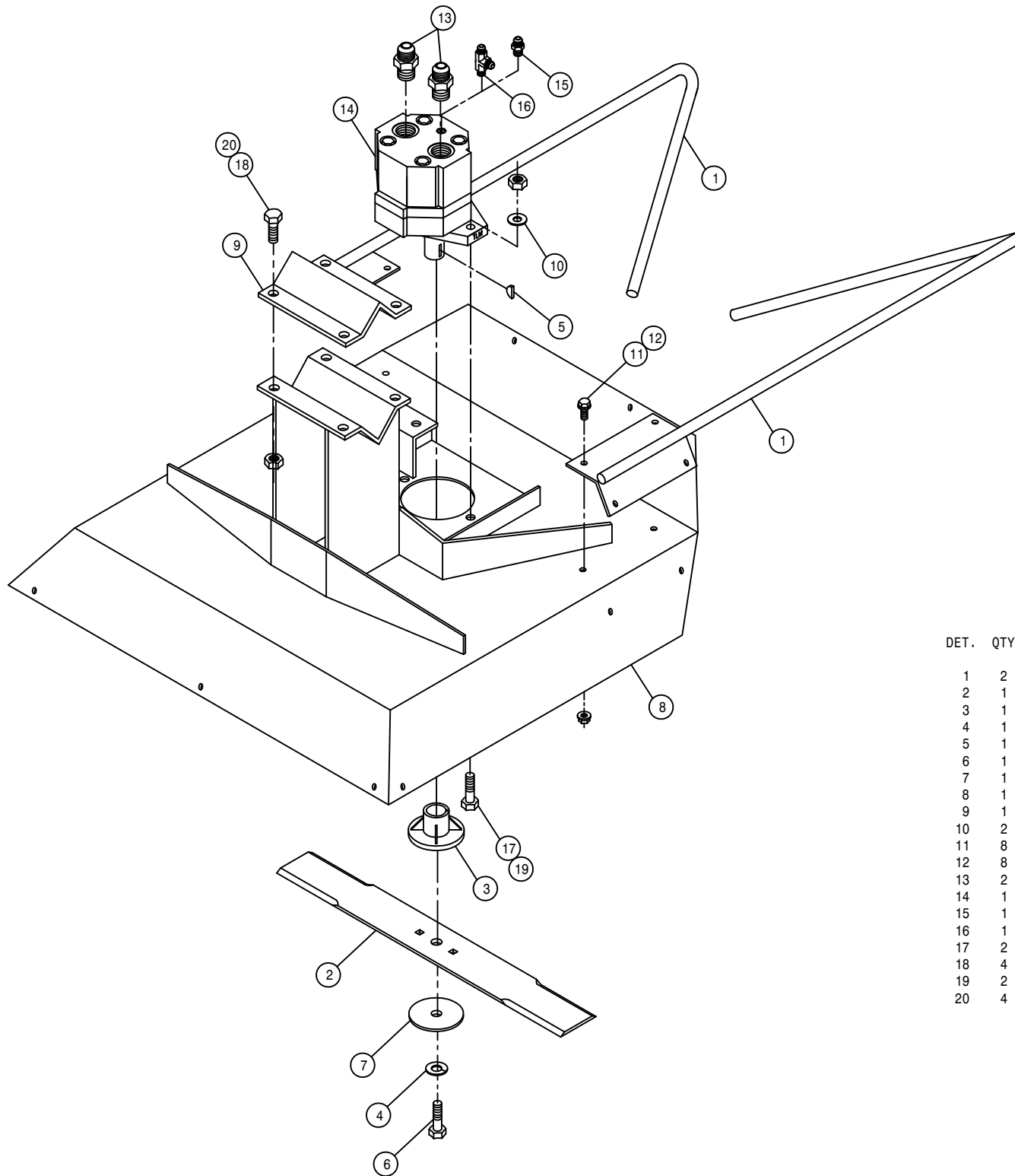

CUTTER HEAD ASSEMBLY

DET.	QTY	PART NO.	DESCRIPTION
	1	2	002215 CUTR STALK GUIDE WLD 8200 85
	2	1	002103 CUTR BLADE 18 IN
	3	1	002104 CLUTCH BODY BLADE
	4	1	002105 3/8 LOCK WASHER ZINC PLT
	5	1	002106 WOODRUFF KEY #6 .156 X .625
	6	1	002107 3/8UNF X 1 1/2 HEX BOLT CUTR
	7	1	002108 STEEL WASHER CUTTER BLADE
	8	1	002210 CUTR TOP WLD 8200 85
	9	1	410016 RLR HANGER V 473
	10	2	920002 3/8 SAE FLAT WASHER
	11	8	470118 1/4UNC X 3/4 FLANGE HEX BOLT
	12	8	470121 1/4UNC HEX FLANGE LOCK NUT
	13	2	611125 3/4MJIC-3/4MOR ADPTR
	14	1	610755 BARNES HYD MOTOR, D-SERIES 01
	15	1	618530 9/16MJIC-1/8MNPT ADPTR
	16	1	618546 1/8MNPT RUN TEE-9/16MJIC
	17	2	900130 3/8UNC X 1 1/4 HEX BOLT
	18	4	900265 1/2UNC X 1 1/2 HEX BOLT
	19	2	914004 3/8UNC HEX STOVER NUT
	20	4	914008 1/2UNC HEX STOVER NUT

LEFT SIDE OF OPERATOR

RIGHT SIDE OF OPERATOR

LEFT SIDE OF OPERATOR

RIGHT SIDE OF OPERATOR

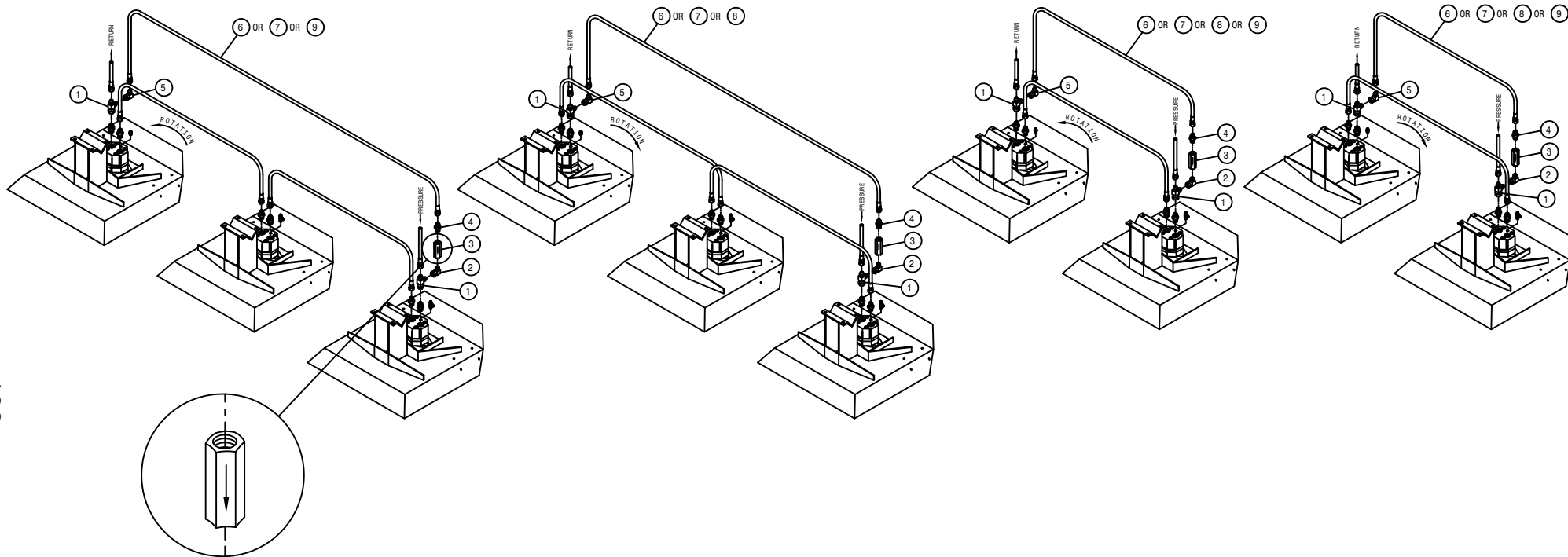

CUTTER CHECK VALVE HYDRAULIC SCHEMATIC

DET. QTY PART NO. DESCRIPTION

1	2	618451	3/4FJIC SW RUN TEE-3/4MJIC	
2	1	618620	3/4FJX-90-1/2MNPT ADPTR	
3	1	690338	LINE CHECK VALVE HYD .50NPT	
4	1	611147	3/4MJIC-1/2MNPT ADPTR	
5	1	618609	3/4MJIC-90-3/4FJIC SWIV LBO	
6	1	614375	08C1T-08FJX-08FJX-177	H/A
7	1	616057	08C1T-08FJX-08FJX-88	H/A
8	1	614368	08C1T-08FJX-08FJX-60	H/A
9	1	614384	08C1T-08FJX-08FJX-237	H/A

NOTE: LISTING IS FOR ONE GROUP OF CUTTER HEADS.

NOTICE

The following page contains decals for the model STS 10.

These decals can be obtained from Hagie Mfg. Co. and should be used whenever your machine is repainted or when the decals become worn, weathered, or faded.

Special attention should be paid to decals involving personal safety. They have been attached for your protection.

KEEP THEM IN PLACE.

**Contact: Hagie Manufacturing Co.
Box 273
Clarion, Iowa 50525**

STS10 DECALS

<u>QTY.</u>	<u>PART NO.</u>	<u>DESCRIPTION</u>	<u>LOCATION</u>
1	650100	TREAD ADJ SWITCH PANEL DECAL	ON THE SWITCH PANEL
1	650102	HYDROSTATIC CONTROL PANEL DECAL	ON HYDRO LEVER MOUNT
4	650103	TREAD ADJUST INDICATOR DECAL	1-ON EACH LEG SLIDE TUBE
1	650105	SOLUTION TANK DECAL SET	ON SOLUTION TANK
1	650106	AGITATION VALVE DECAL	ON AGITATION ELECT VALVE
1	650107	CAUTION BOOSTER DECAL	NEAR BOOSTER POSTS
1	650108	MAIN SPRAY POWER DECAL	ON ATI CONTROL BOX
1	650109	LOW HYDRAULIC OIL DECAL	ON ATI CONTROL BOX
1	650110	PRESSURE WASHER DECAL	ON PRESSURE WASHER SWITCH BOX
1	650111	CHEMICAL INDUCTOR CONTROL DECAL	ON CHEM INDUCTOR CONTROL BOX
1	650112	HAGIE UPFRONT STRG WHEEL DECAL	ON STEERING WHEEL
1	650113	EMERGENCY EXIT DECAL	ON RH SIDE WINDOW HANDLE
1	650114	FILL WITH FRESH WATER DECAL	ON FRESH WATER TANK
1	650115	HAND WASH ONLY DECAL	NEAR HAND WASH VALVE
1	650116	INDUCTOR FILL INSTRUCTION DECAL	ON SIDE OF FILL ARM
1	650117	LATCH RELEASE DECAL	1-REAR RAD GRILLE DOOR
1	650118	DO NOT USE EITHER DECAL	NEAR AIR INTAKE ON SHEET METAL
1	650120	LATCH RELEASE W/ARROW DECAL	1-ENGINE SIDE DOOR
1	650212	ENG COMPARTMENT DECAL SET STS10	ON ENGINE SHEET METAL
1	650337	ELECTROCUTION HAZARD DECAL	ON RH SIDE WINDOW
2	650339	WARNING, HYD OIL INJ DECAL	1-ON SIDE OF OIL TANK
1	650340	CAUTION, PARKING BRAKE DECAL	1-NEAR ELECTIC VALVE ON TRANSOM ON RH SIDE WINDOW
1	650347	NOTICE-R134 DECAL	RH SIDE OF ENGINE ON FRAME
1	650848	CAUTION, SLIP OR FALL DECAL	ON LADDER PIVOT TUBE
1	650849	CAUTION, ENGINE FUEL DECAL	NEAR FUEL TANK NECK
1	650850	DANGEROUS CHEM DECAL	SOLUTION TANK FILLER NECK
1	650851	SHIELDS DECAL	ON LOWER LH REAR MAINFRAME TUBE
1	650852	READ MANUAL DECAL	ON LEFT SIDE WINDOW
1	650954	DIESEL DECAL	NEAR FUEL TANK NECK
1	650981	COOLING SYSTEM DECAL	NEAR RADIATOR CAP
1	650982	ELECTRICAL DECAL	ON RH CAB DOOR
4	650985	WHEEL BOLT TORQUE DECAL	ON EACH WHEEL RIM
1	650348	NOTICE-DRAIN AIR TANK DECAL	ON AIR TANK
1	650363	FRONT RECEPTACLE PANEL DECAL	ON FRONT RECEPTACLE PANEL
1	650365	LADDER DO NOT STAND DECAL	ON TOP OF LADDER PIVOT TUBE
1	650367	AIR FILTER INSTRUCTION DECAL	ON ENGINE AIR FILTER END CAP
2	650819	DANGER, CUTTING BLADES DECAL	2-ON EACH CUTTER HEAD

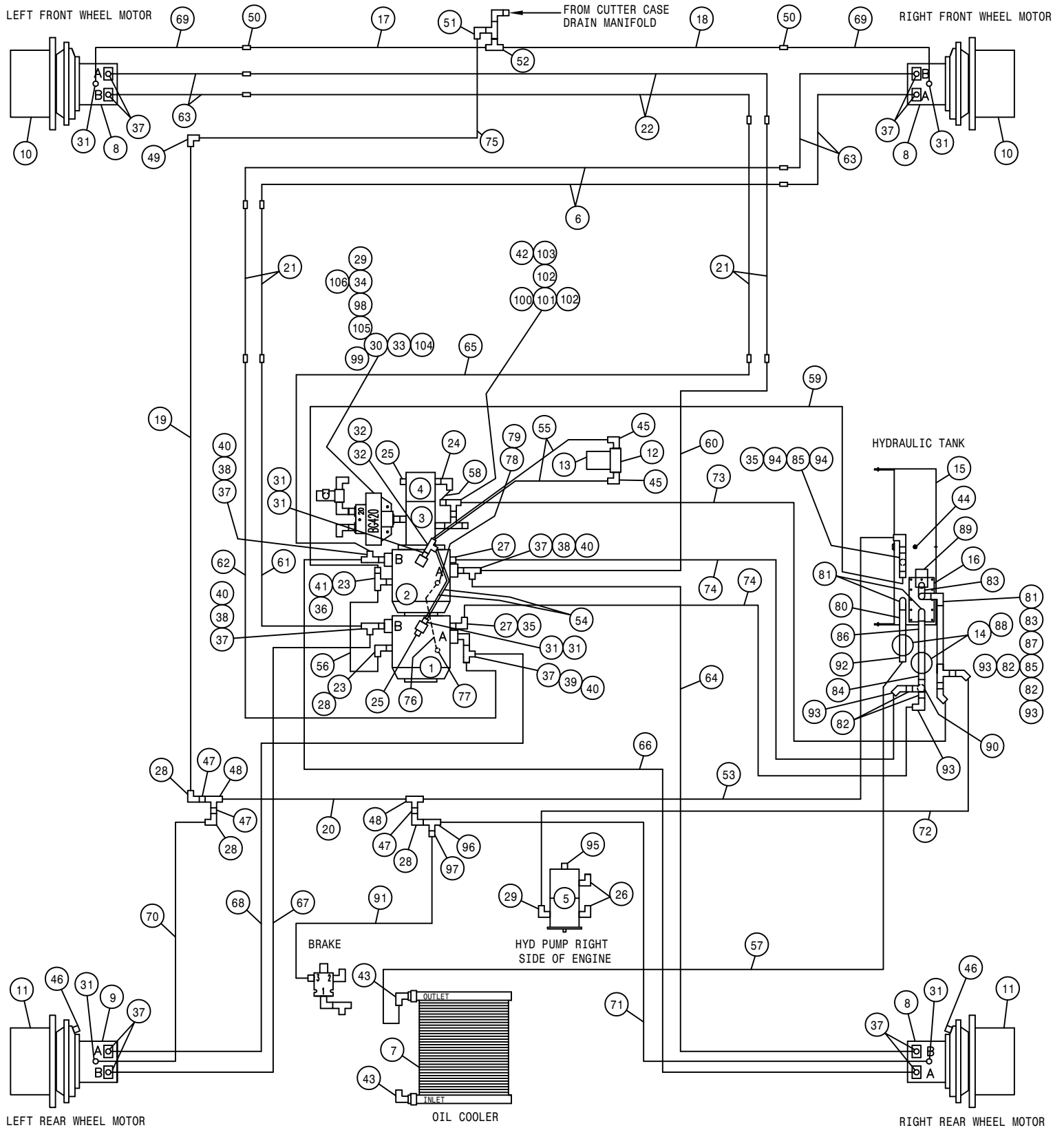

STS10 COMBO HYDRAULIC SCHEMATIC 2002
REFERENCE DRAWING NO. 498677S1

DET.	QTY	PART NO.	DESCRIPTION	DET.	QTY	PART NO.	DESCRIPTION	
1	1	606966	SUND 75CC PUMP,C/C-MT	54	2	616099	08-451TC-08FJX-08FJX-16	H/A
2	1	606969	SUND 75CC PUMP,C/B-MT	55	2	616100	08-451TC-08FJX-08FJX-19	H/A
3	1	606087	SAUER GEAR PUMP,3.87CI GRP3	56	1	616107	08-451TC-12FJX-12FJX-17	H/A
4	1	606987	SUND GEAR PUMP,.128CI GRP3	57	1	616116	16-421HT-16FJX-20FJX-154	H/A
5	1	606990	TANDEM PUMP, .66CI/.51CI	58	1	616117	06-451TC-06FJX-06FJX-17	H/A
6	2	615784	RH FRT WHL MAIN HYD TUBE ASSY	59	1	616126	16-421HT-16FJX-16FJX-73	H/A
7	1	618800	OIL COOLER STS12 2000	60	1	616061	16C15-16FFOX-16FFOX-30	H/A
8	3	606978	SUND HYD MOTOR	61	1	616062	16C15-16FFOX-16FFOX-58	H/A
9	1	606981	SUND HYD MOTOR W/SENSOR	62	1	616063	16C15-16FFOX-16FFOX90-81	H/A
10	2	610711	TORQ HUB, 22:1 CW12	63	4	616064	16C15-16FFOX-16FLG-132	H/A
11	2	610714	TORQ HUB, 27:1 CW12	64	1	616065	16C15-16FFOX-16FLG-165	H/A
12	1	605608	HYD FILTER HEAD, DONALDSON	65	1	616066	16C15-16FFOX90-16FFOX90-38	H/A
13	1	605609	HYD FILTER ELEMENT, DONALDSON	66	1	616067	16C15-16FFOX90-16FLG-193	H/A
14	2	605611	FILTER HEAD, 1 1/2FNPTF ZINGA	67	1	616068	16C15-16FFOX90-16FLG-203	H/A
15	1	760231	HYD TANK WLD STS12	68	1	616069	16C15-16FFOX90-16FLG-223	H/A
16	1	760239	RECEIVER PLATE WLD STS12	69	2	616103	08-451TC-08FJX-10FJX-136	H/A
17	1	615775	LH FRT CASEDRAIN HYD TUBE ASSY	70	1	616104	08-451TC-08FJX-12FJX-160	H/A
18	1	615776	RH FRT CASEDRAIN HYD TUBE ASSY	71	1	616106	08-451TC-08FJX-12FJX-175	H/A
19	1	615778	FRT CASE DRAIN HYD TUBE ASSY	72	1	616110	16-451TC-12FJX-16FJX-84	H/A
20	1	615779	CASE DRAIN HYD TUBE ASSY	73	1	616111	16-451TC-16FJX-16FJX-32	H/A
21	4	615785	FRT WHL MAIN HYD TUBE ASSY	74	2	616112	16-451TC-16FJX-16FJX-42	H/A
22	2	615783	LH FRT WHL MAIN HYD TUBE ASSY	75	1	616113	10-421HT-10FJX-12FJX-55	H/A
23	2	611127	1 1/16MJIC-1 1/16MOR ADPTR	76	1	616038	04C2AT-06FJX-06FJX90-15	H/A
24	1	618115	9/16MJIC-90-3/4MOR LBO	77	1	614754	.050 ELBOW ASSY,9/16MOR 90D	
25	2	618126	9/16MJIC-9/16MOR ADPTR	78	1	618444	9/16MOR RUN TEE-9/16MJIC	
26	2	618183	3/4MJIC-90-7/8MOR LBO	79	1	618531	9/16FJIC CAP NUT	
27	2	618186	1 5/16MJIC-1 5/16MOR ADPTR	80	1	507009	BLK PIPE NIPPLE 1.50NPT-6.00	
28	4	618191	1 1/16MJ-90-1 1/16FJ SWIV LBO	81	3	507014	BLK PIPE EL 90DEG 1.50NPT	
29	2	618248	1 1/16MJIC-90-1 1/16MOR LBO	82	4	507015	RED BUSH 1.50NPT - 1.25FNPT	
30	1	606074	FLO DIV BG420 20GPM PRI 16FOR	83	2	507018	BLK PIPE ST EL 90DEG 1.50NPT	
31	8	618327	3/4MJIC-7/8MOR ADPTR	84	1	507019	CLOSE NIPPLE 1.50NPT	
32	2	618451	3/4FJIC SW RUN TEE-3/4MJIC	85	2	507250	BLK PIPE TEE 1.50NPT	
33	1	618471	1 5/8MJIC-1 5/16MOR ADPTR	86	1	507610	BLK PIPE NIPPLE 1.50NPT-8.00	
34	1	607550	IN-LINE RELIEF VALVE, 2600 PSI	87	1	507617	BLK PIPE NIPPLE 1.50NPT-16.00	
35	2	618640	1 5/16MJ-90-1 5/16FJ SWIV LBO	88	2	605612	FILTER, 10 MICRON ZINGA	
36	1	618641	1 1/16FJIC-1 5/16MJIC ADPTR	89	1	605613	TANK FILTER,100 MESH,1 1/2FNPT	
37	12	618652	1" SPLIT FLANGE KIT	90	1	507252	SIDE OUTLET EL 90DEG 1.50NPT	
38	3	618653	1" FLANGE-1 7/16MFOR ADPTR	91	1	616078	04-451TC-06FJX-06FJX-26	H/A
39	1	618654	1" FLANGE-90-1 7/16MFOR LBO	92	1	618656	1 5/8MJIC-1 1/2MNPT ADPTR	
40	4	618655	1 7/16FFOX RUN TEE-1 7/16MFOR	93	4	618667	1 5/16MJIC-45-1 1/4MNPT LBO	
41	1	618660	1 1/16FJX BRANCH TEE-1 1/16MJ	94	2	618672	1 5/16MJIC-1 1/2MNPT ADPTR	
42	1	618661	1 5/16FJIC-9/16MJIC ADPTR	95	1	618315	3/4MJIC-45-3/4MOR LBO	
43	2	618463	1 5/16MJIC-90-1 5/16MOR XL LBO	96	1	618487	1 1/16FJ SW RUN TEE-1 1/16MJ	
44	1	470308	1/2MNPT DRAIN PLUG,AL HD,MAG	97	1	618483	1 1/16FJIC-9/16MJIC ADPTR	
45	2	618474	3/4MJIC-90-1 1/16MOR LBO	98	1	618684	1 1/16MOR-90-1 1/16FJIC SWIV	
46	2	618666	7/16MJIC-M12X1.5MOR ADPTR	99	1	618178	1 5/16MJIC-90-1 5/16MOR LBO	
47	3	618541	1 5/16FJIC-1 1/16MJIC ADPTR	100	1	618682	1 7/8MOR-1 7/8MJIC ADPTR	
48	2	618658	1 5/16MJIC UNION TEE	101	1	618681	1 7/8FJ SW RUN TEE-1 7/8MJ	
49	1	618448	1 1/16MJIC-90-1 1/16MJIC LBO	102	2	618680	1 7/8FJIC-1 5/16MJIC ADPTR	
50	2	618456	7/8MJIC UNION	103	1	618717	1 5/16FJX BRANCH TEE-1 5/16MJ	
51	1	618301	7/8MJIC-90-7/8FJIC SWIV LBO	104	1	618683	1 5/8MOR-1 5/8FJIC SWIV ADPTR	
52	1	618581	7/8MJIC UNION TEE	105	1	618308	1 1/16MJIC-1 5/16MOR ADPTR	
53	1	616127	16-421HT-16FJX-16FJX90-73 H/A	106	1	618279	1 1/16MJIC-90-7/8MOR LBO	

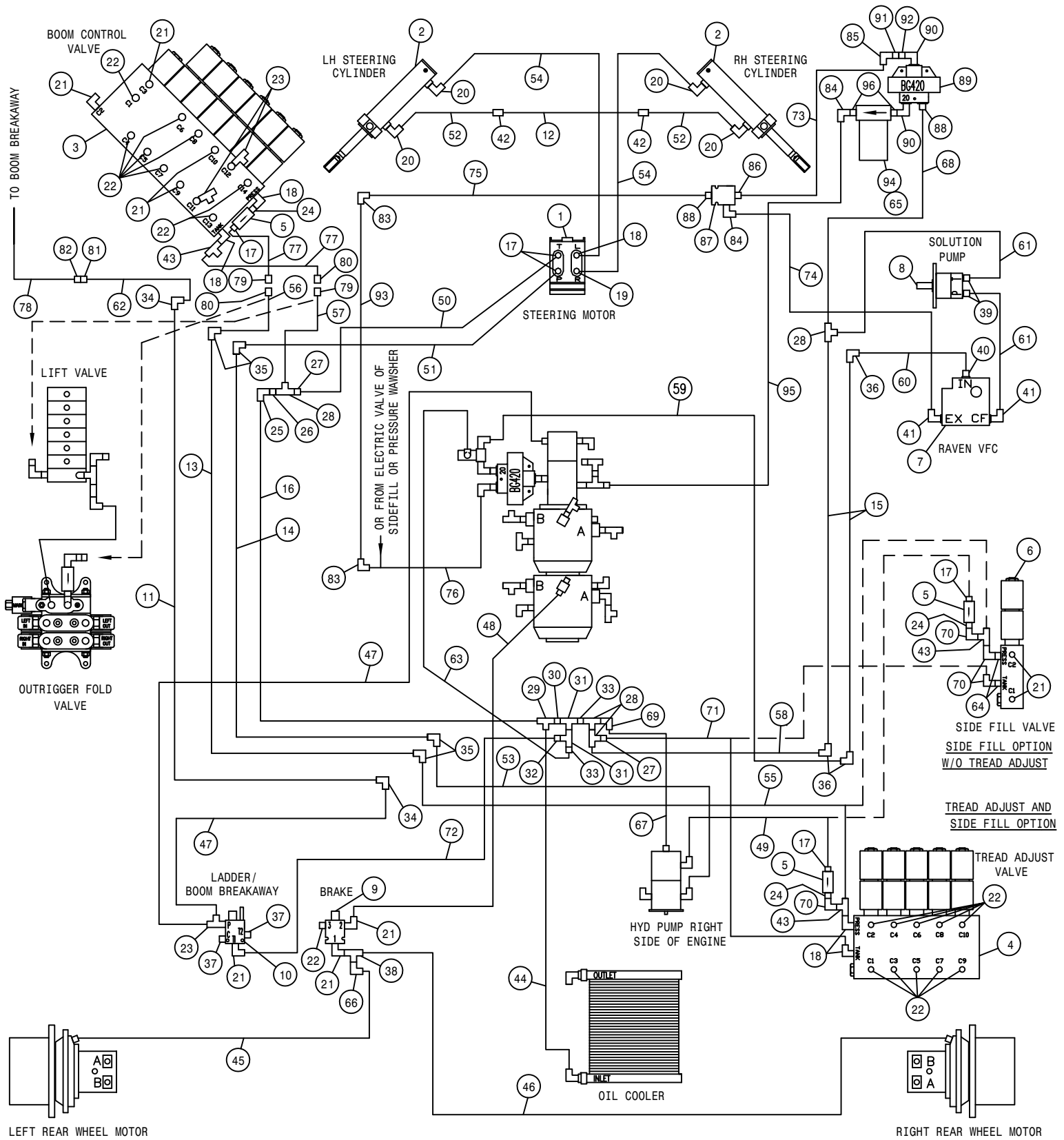

STS10 COMBO HYDRAULIC SCHEMATIC 2002
REFERENCE DRAWING NO. 498677S2

DET.	QTY	PART NO.	DESCRIPTION	DET.	QTY	PART NO.	DESCRIPTION	
1	1	749321	STEERING CONTROL MTR 14.1CI	49	1	616093	08-451TC-08FJX-08FJX-86	H/A
2	2	620910	STEERING CYL,2.50 X 8.81	50	1	616094	06-451TC-08FJX-08FJX-31	H/A
3	1	606051	DELTA HYD MANIFOLD ASSY, 2703	51	1	616095	06-451TC-08FJX-08FJX-33	H/A
4	1	606050	DELTA HYD MANIFOLD ASSY, 2704	52	2	616096	06-451TC-08FJX-08FJX-37	H/A
5	3	605610	HYD FILTER, INLINE 90M 3/4FOR	53	1	616097	08-451TC-08FJX-08FJX-90	H/A
6	1	606094	SIDEFILL VLV,COIL W/WIRE LEADS	54	2	616098	06-451TC-08FJX-08FJX-94	H/A
7	1	690666	VALVE HYD CTRL,30GPM RAVEN	55	1	616101	08-451TC-08FJX-08FJX-31	H/A
8	1	690670	HYPRO PUMP, 9305C-HM3CB	56	1	616164	08-451TC-08FJX-08MP-60	H/A
9	1	606013	BRAKE VLV W/TOWER ASSY	57	1	616166	08-451TC-12FJX-08MP-60	H/A
10	1	606011	LADDER/BRKWAY VLV W/TOWER ASSY	58	1	616108	10-451TC-12FJX-12FJX-28	H/A
11	1	615771	BRKAWAY/TRD MAIN HYD TUBE ASSY	59	1	616109	10-451TC-12FJX-12FJX-32	H/A
12	1	615772	STRG CYL JUMPER HYD TUBE ASSY	60	1	616120	10-451TC-12FJX-12FJX-16	H/A
13	1	615773	STACK VALVE MAIN HYD TUBE ASSY	61	2	616121	10-451TC-12FJX90-12FJX-32	H/A
14	1	615774	STEERING MAIN HYD TUBE ASSY	62	1	616162	04-451TC-06FJX-06MP-60	H/A
15	2	615777	SOLUTION PUMP HYD TUBE ASSY	63	1	616132	08-451TC-12FJX-12FJX-18	H/A
16	1	615782	FRT MAIN RETURN HYD TUBE ASSY	64	2	618160	3/4MJIC-7/16MOR ADPTR	
17	5	611125	3/4MJIC-3/4MOR ADPTR	65	1	605612	FILTER, 10 MICRON	ZINGA
18	5	618241	3/4MJIC-90-3/4MOR LBO	66	1	618618	9/16MJIC-90-9/16FJIC SWIV LBO	
19	1	618443	3/4MJIC-90-3/4MOR EX LG LBO	67	1	616136	08-451TC-08FJX-12FJX-72	H/A
20	4	618249	3/4MJIC-90-9/16MOR LBO	68	1	616151	12-451TC-12MJ-16FJX-44	H/A
21	7	618119	9/16MJIC-90-9/16MOR LBO	69	1	618191	1 1/16MJ-90-1 1/16FJ SWIV LBO	
22	21	618126	9/16MJIC-9/16MOR ADPTR	70	4	618609	3/4MJIC-90-3/4FJIC SWIV LBO	
23	3	618444	9/16MOR RUN TEE-9/16MJIC	71	1	616139	08-451TC-08FJX-08FJX-36	H/A
24	3	618669	3/4FJIC SWIV-3/4MOR ADPTR	72	1	616083	04-451TC-06FJX-06FJX-36	H/A
25	1	618657	1 5/8MJIC-90-1 5/8MJIC LBO	73	1	616155	20C12-20FJX-20FJX-42	H/A
26	1	618665	1 5/8FJIC-1 1/16MJIC ADPTR	74	1	616149	12-451TC-12FJX-16FJX-105	H/A
27	2	618484	1 1/16FJIC-3/4MJIC ADPTR	75	1	616152	12-451TC-16FJX-16FJX90-50	H/A
28	4	618487	1 1/16FJ SW RUN TEE-1 1/16MJ	76	1	616153	12-451TC-16FJX-16FJX90-35	H/A
29	1	618659	1 5/8MJIC UNION TEE	77	2	616165	08-451TC-08FJX-08MP-72	H/A
30	1	618547	1 5/8FJIC-1 5/16MJIC ADPTR	78	1	616163	04-451TC-06FJX-06MP-82	H/A
31	2	618619	1 5/16FJ SW RUN TEE-1 5/16MJ	79	2	618622	HYD QUICK CPLR, MALE, .50FNPS	
32	1	618661	1 5/16FJIC-9/16MJIC ADPTR	80	2	618621	HYD QUICK CPLR,FEMALE, .50FNPS	
33	2	618541	1 5/16FJIC-1 1/16MJIC ADPTR	81	1	618645	HYD QUICK CPLR,FEMALE .375NPS	
34	2	618603	9/16MJIC-90-9/16MJIC LBO	82	1	618646	HYD QUICK CPLR, MALE .375NPS	
35	4	618442	3/4MJIC-90-3/4MJIC LBO	83	2	618441	1 5/16MJIC-90-1 5/16MJIC LBO	
36	3	618448	1 1/16MJIC-90-1 1/16MJIC LBO	84	2	618178	1 5/16MJIC-90-1 5/16MOR LBO	
37	1	610185	9/16MOR PLUG	85	1	618476	1 5/8MJIC-90-1 5/16MOR LBO	
38	1	618486	9/16FJIC SW RUN TEE-9/16MJIC	86	1	618472	1 5/8MJIC-1 5/8MOR ADPTR	
39	2	618273	1 1/16MJIC-1/2MNPT ADPTR	87	1	606075	MANIFOLD, 1 5/16FOR & 1 5/8FOR	
40	1	611127	1 1/16MJIC-1 1/16MOR ADPTR	88	2	618186	1 5/16MJIC-1 5/16MOR ADPTR	
41	2	618248	1 1/16MJIC-90-1 1/16MOR LBO	89	1	606074	FLO DIV BG420 20GPM PRI 16FOR	
42	2	618314	3/4MJIC UNION	90	2	618685	1 5/16MOR-90-1 5/16MOR LBO	
43	3	618451	3/4FJIC SW RUN TEE-3/4MJIC	91	1	618686	HYD QUICK CPLR,FEMALE 1.00UNF	
44	1	616115	16-421HT-16FJX-20FJX-100	92	1	618687	HYD QUICK CPLR, MALE 1.00UNF	
45	1	616072	04-451TC-04FJX45-06FJX-195	93	1	615807	PRESS HYD TUBE ASSY,STS12COMBO	
46	1	616073	04-451TC-04FJX45-06FJX-202	94	1	605614	FILTER HEAD, 1 7/8FOR ZINGA	
47	2	616080	04-451TC-06FJX-06FJX-30	95	1	616154	16-451TC-16FJX-16FJX45-144	H/A
48	1	616081	04-451TC-06FJX-06FJX-31	96	2	618707	1 7/8MOR-1 5/16FOR ADPTR	

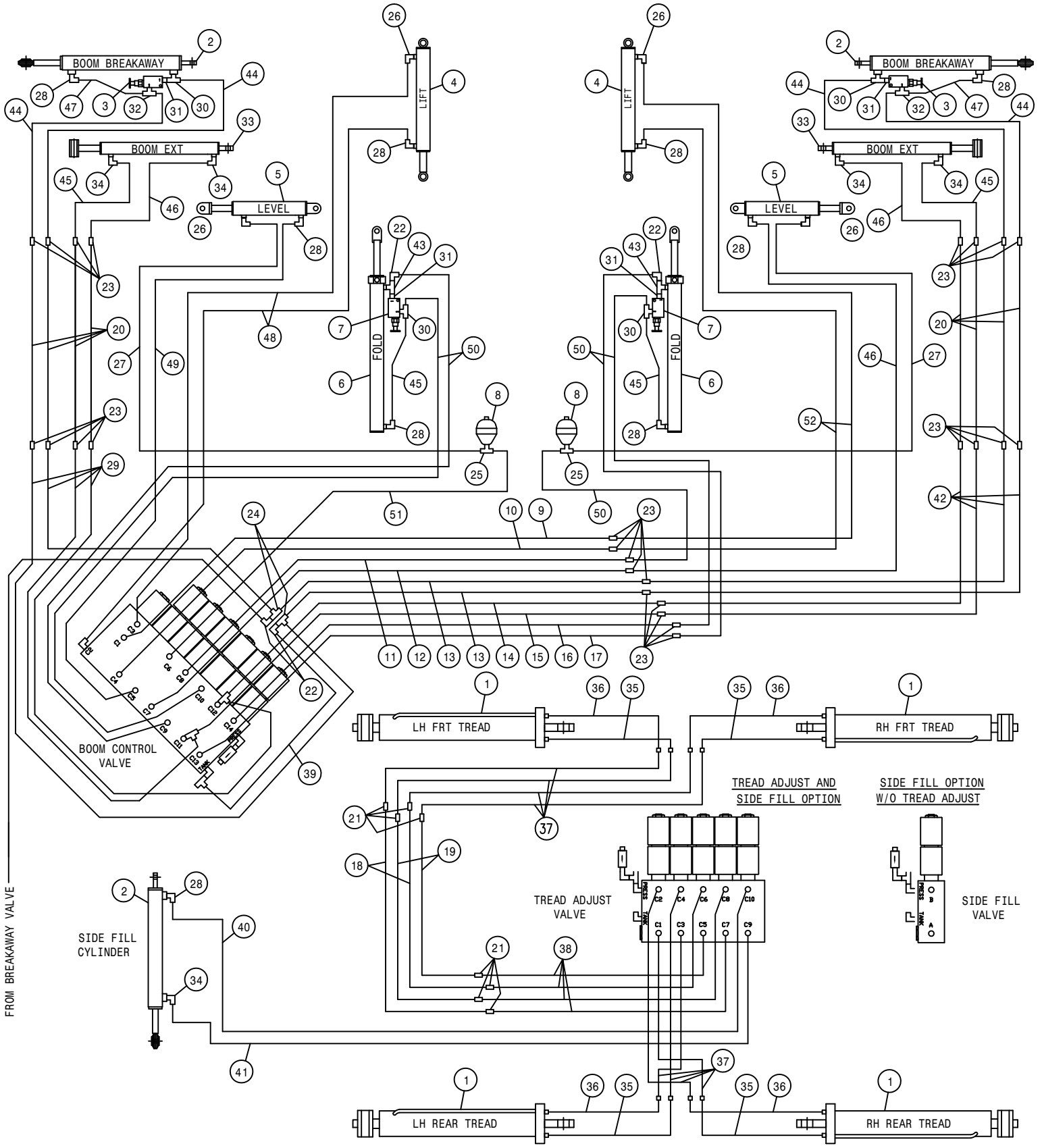

STS10 COMBO HYDRAULIC SCHEMATIC 2002
REFERENCE DRAWING NO. 498677S3

DET.	QTY	PART NO.	DESCRIPTION	DET.	QTY	PART NO.	DESCRIPTION
1	4	620915	TRD ADJ CYL, 3.00 X 16.00	29	4	616133	04-451TC-06FJX-06FJX-72 H/A
2	3	620920	LADDER CYL, 1.50 X 12.25	30	4	618629	9/16MOR BRANCH TEE-9/16MJIC
3	2	607540	KICK-DOWN RELIEF VALVE, 800PSI	31	4	618668	9/16FJIC SWIV-9/16MOR ADPTR
4	2	620925	LIFT CYL, 2.50 X 18.00	32	2	614752	RESTRICTOR BR TEE ASSY, .042DIA
5	2	620950	LEVEL CYL, 3.00 X 11.00	33	2	620945	OUTR FOLD CYL, 2.25 X 21.00
6	2	620940	FOLD CYL, 2.50 X 21.00	34	5	614750	.042 ELBOW ASSY, 9/16MOR 90D
7	2	607541	KICK-DOWN RELIEF VALVE, 4500PSI	35	4	616070	04-451TC-04MJBH-06MOR-11.00H/A
8	2	470326	ACCUMULATOR, DIAPHRAGM	36	4	616071	04-451TC-04MJBH-06MOR-13.00H/A
9	1	615761	LIFT RAISE HYD TUBE ASSY	37	8	616074	04-451TC-04FJX90-06FJX-26 H/A
10	1	615762	LIFT LOWER HYD TUBE ASSY	38	4	616079	04-451TC-06FJX-06FJX-29 H/A
11	1	615763	LEVEL RAISE HYD TUBE ASSY	39	1	616124	04-451TC-06FJX-08FJX-24 H/A
12	1	615764	LEVEL LOWER HYD TUBE ASSY	40	1	616118	04-451TC-06FJX-06FJX-165 H/A
13	2	615765	BREAKAWAY HYD TUBE ASSY	41	1	616119	04-451TC-06FJX-06FJX-175 H/A
14	1	615766	BOOM EXTN RAISE HYD TUBE ASSY	42	4	616089	04-451TC-06FJX-06FJX-60 H/A
15	1	615767	BOOM EXTN LOWER HYD TUBE ASSY	43	2	614756	RESTRICTOR BR TEE ASSY, .025DIA
16	1	615768	RH FOLD RAISE HYD TUBE ASSY	44	4	616090	04-451TC-06FJX-06FJX-85 H/A
17	1	615769	RH FOLD LOWER HYD TUBE ASSY	45	4	616077	04-451TC-06FJX-06FJX-18 H/A
18	2	615770	FRT TRD ADJ MAIN HYD TUBE ASSY	46	3	616083	04-451TC-06FJX-06FJX-36 H/A
19	2	615771	BRKAWAY/TRD MAIN HYD TUBE ASSY	47	2	616075	04-451TC-06FJX-06FJX-9 H/A
20	8	615760	BOOM HYD TUBE ASSY	48	2	616084	04-451TC-06FJX-06FJX-46 H/A
21	8	618603	9/16MJIC-90-9/16MJIC LBO	49	1	616085	04-451TC-06FJX-06FJX-43 H/A
22	4	618618	9/16MJIC-90-9/16FJIC SWIV LBO	50	5	616086	04-451TC-06FJX-06FJX-45 H/A
23	26	619010	9/16MJIC UNION	51	1	616087	04-451TC-06FJX-06FJX-52 H/A
24	2	618019	9/16MJIC UNION TEE	52	2	616088	04-451TC-06FJX-06FJX-56 H/A
25	2	618673	3/4MOR BRANCH TEE-9/16MJIC	53	2	618673	3/4MOR BRANCH TEE-9/16MJIC
26	4	618689	9/16MOR-90-9/16MJ .042 CHK VLV	54	2	616128	06-451TC-06FJX-06FJX-48 H/A
27	2	616128	06-451TC-06FJX-06FJX-48 H/A	55	4	616133	04-451TC-06FJX-06FJX-72 H/A
28	9	618119	9/16MJIC-90-9/16MOR LBO				

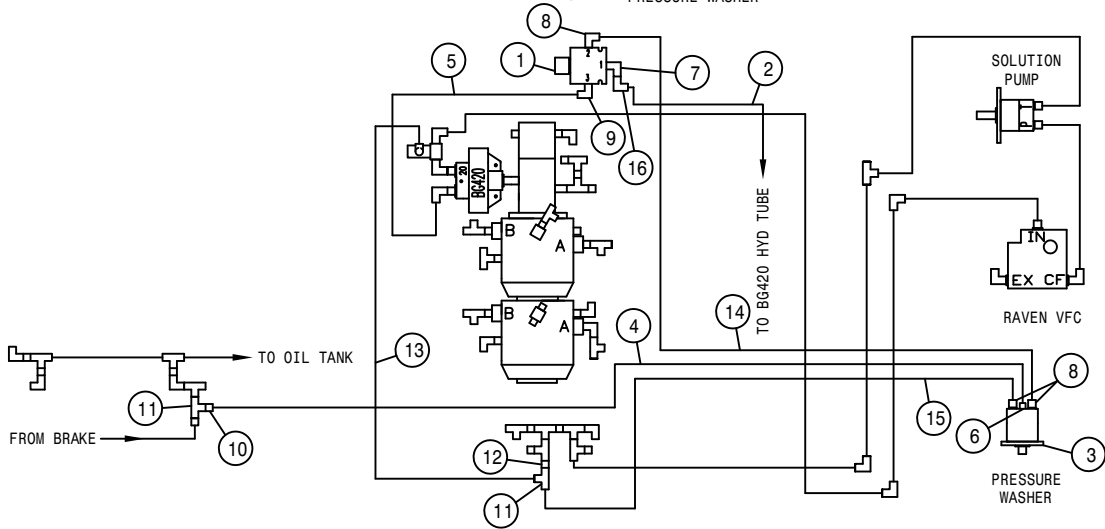
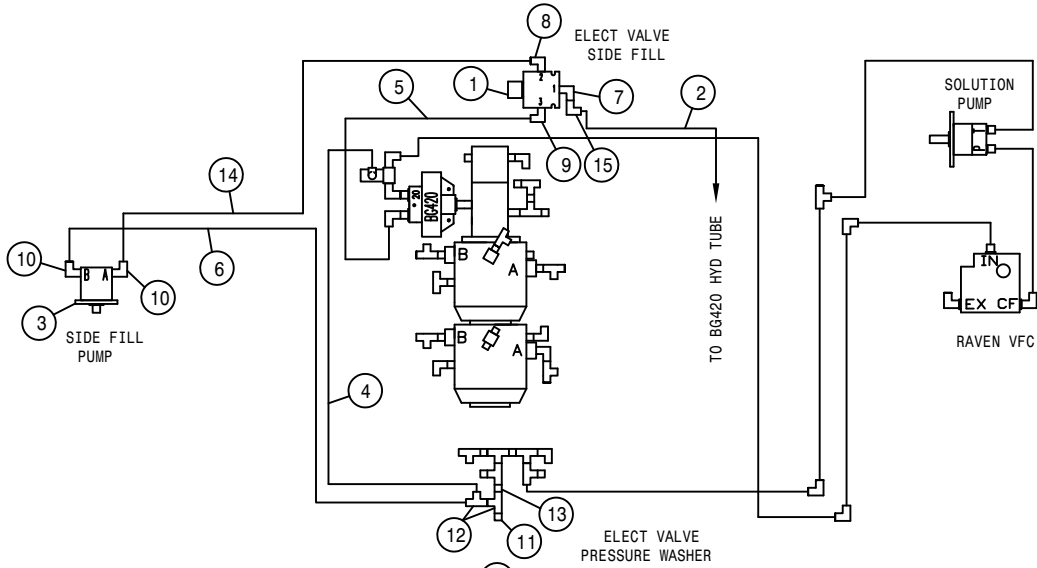
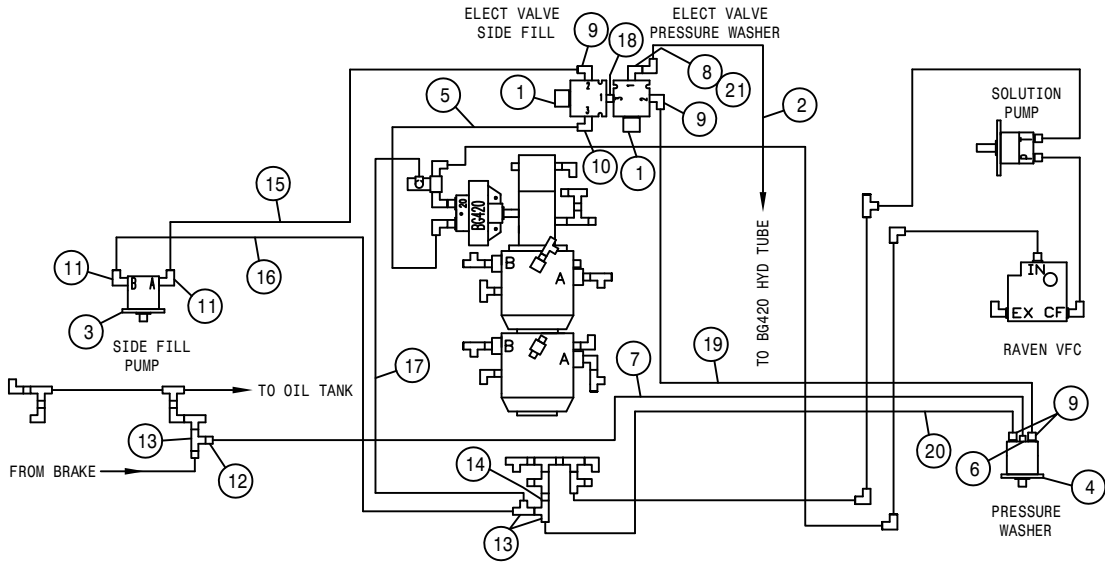

SIDE FILL AND PRESSURE WASHER OPTION
REFERENCE DRAWING NO. 498677S4

DET.	QTY	PART NO.	DESCRIPTION
	1	2 606015	SIDE-FILL/WASH VLV W/SHRD ASSY
	2	1 616150	12-451TC-12FJX-16FJX90-40 H/A
	3	1 690760	BANJO PUMP,3" SIDE FILL STS12
	4	1 690672	PRESSURE WASHER,PACE 320 HYD
	5	1 616148	12-451TC-12FJX-16FJX-22 H/A
	6	1 618119	9/16MJIC-90-9/16MOR LBO
	7	1 616089	04-451TC-06FJX-06FJX-60 H/A
	8	1 618248	1 1/16MJIC-90-1 1/16MOR LBO
	9	4 618474	3/4MJIC-90-1 1/16MOR LBO
	10	1 618674	1 1/16MJIC-90-1 1/16MOR XL LBO
	11	2 618183	3/4MJIC-90-7/8MOR LBO
	12	1 618483	1 1/16FJIC-9/16MJIC ADPTR
	13	3 618487	1 1/16FJ SW RUN TEE-1 1/16MJ
	14	1 618541	1 5/16FJIC-1 1/16MJIC ADPTR
	15	1 616129	08-451TC-08FJX-08FJX-204 H/A
	16	1 616130	08-451TC-08FJX-12FJX-204 H/A
	17	1 616132	08-451TC-12FJX-12FJX-18 H/A
	18	1 618675	1 1/16MOR UNION
	19	1 616135	08-451TC-08FJX-08FJX-50 H/A
	20	1 616134	08-451TC-08FJX-12FJX-60 H/A
	21	1 618191	1 1/16MJ-90-1 1/16FJ SWIV LBO

SIDE FILL OPTION

DET.	QTY	PART NO.	DESCRIPTION
	1	1 606015	SIDE-FILL/WASH VLV W/SHRD ASSY
	2	1 616150	12-451TC-12FJX-16FJX90-40 H/A
	3	1 690760	BANJO PUMP,3" SIDE FILL STS12
	4	1 616132	08-451TC-12FJX-12FJX-18 H/A
	5	1 616148	12-451TC-12FJX-16FJX-22 H/A
	6	1 616130	08-451TC-08FJX-12FJX-204 H/A
	7	1 618248	1 1/16MJIC-90-1 1/16MOR LBO
	8	1 618474	3/4MJIC-90-1 1/16MOR LBO
	9	1 618674	1 1/16MJIC-90-1 1/16MOR XL LBO
	10	2 618183	3/4MJIC-90-7/8MOR LBO
	11	1 618483	1 1/16FJIC-9/16MJIC ADPTR
	12	2 618487	1 1/16FJ SW RUN TEE-1 1/16MJ
	13	1 618541	1 5/16FJIC-1 1/16MJIC ADPTR
	14	1 616129	08-451TC-08FJX-08FJX-204 H/A
	15	1 618191	1 1/16MJ-90-1 1/16FJ SWIV LBO

PRESSURE WASHER OPTION

DET.	QTY	PART NO.	DESCRIPTION
	1	1 606015	SIDE-FILL/WASH VLV W/SHRD ASSY
	2	1 616150	12-451TC-12FJX-16FJX90-40 H/A
	3	1 690672	PRESSURE WASHER,PACE 320 HYD
	4	1 616089	04-451TC-06FJX-06FJX-60 H/A
	5	1 616148	12-451TC-12FJX-16FJX-22 H/A
	6	1 618119	9/16MJIC-90-9/16MOR LBO
	7	1 618248	1 1/16MJIC-90-1 1/16MOR LBO
	8	3 618474	3/4MJIC-90-1 1/16MOR LBO
	9	1 618674	1 1/16MJIC-90-1 1/16MOR XL LBO
	10	1 618483	1 1/16FJIC-9/16MJIC ADPTR
	11	2 618487	1 1/16FJ SW RUN TEE-1 1/16MJ
	12	1 618541	1 5/16FJIC-1 1/16MJIC ADPTR
	13	1 616132	08-451TC-12FJX-12FJX-18 H/A
	14	1 616135	08-451TC-08FJX-08FJX-50 H/A
	15	1 616134	08-451TC-08FJX-12FJX-60 H/A
	16	1 618191	1 1/16MJ-90-1 1/16FJ SWIV LBO

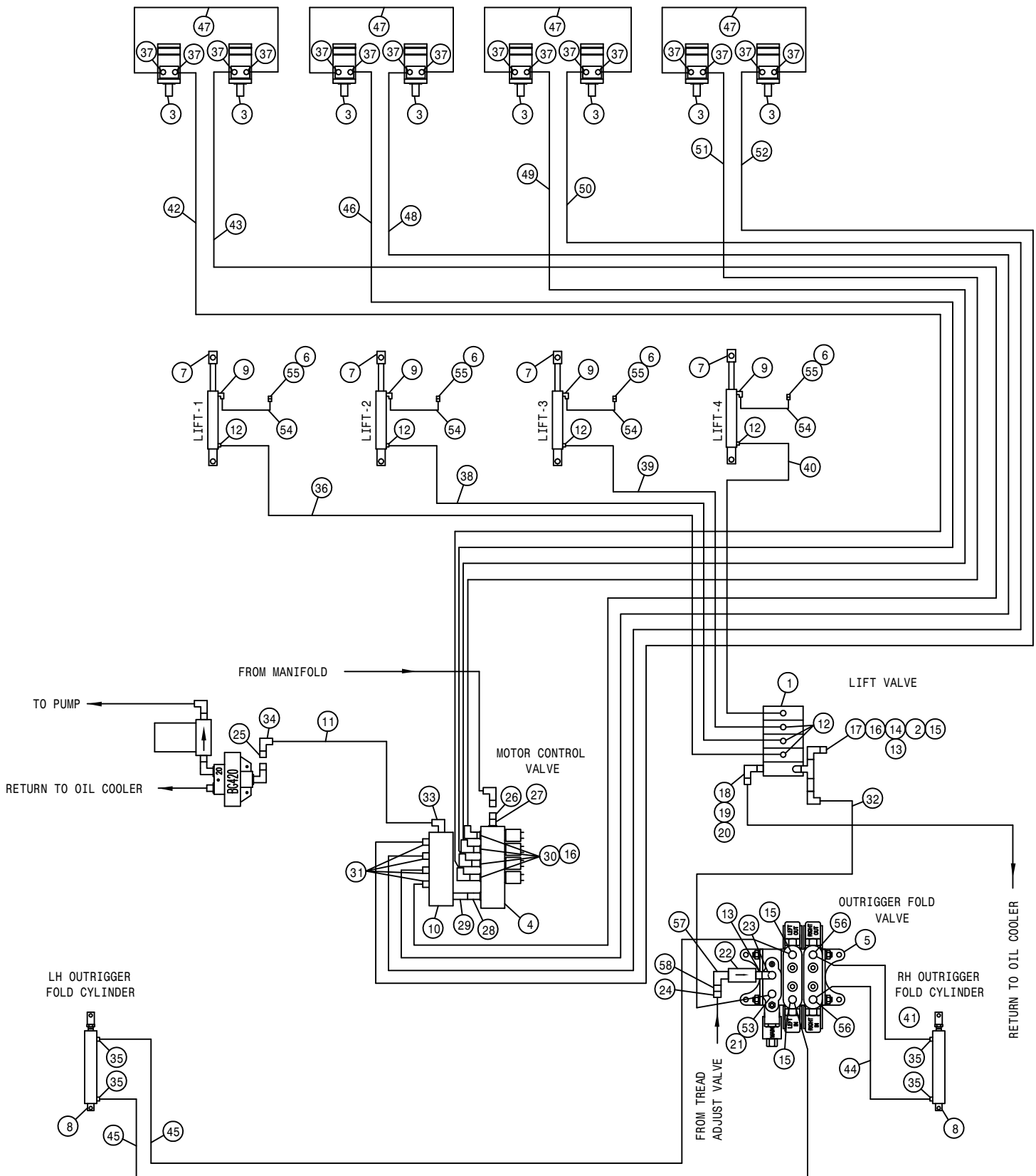

STS COMBO 8R QUAD HYD SCHEM 02
REFERENCE DRAWING NO. 498666

DET.	QTY	PART NO.	DESCRIPTION	DET.	QTY	PART NO.	DESCRIPTION
1	1	610613	ELECT HYD STACT VLV, 4 SECT	30	4	618469	3/4MJIC-1 1/16MOR ADPTR
2	1	605610	HYD FILTER, INLINE 90M 3/4FOR	31	4	611125	3/4MJIC-3/4MOR ADPTR
3	8	610547	HYD MOTOR 4.5CI 1IN SHFT	32	1	616077	04-451TC-06FJX-06FJX-18 H/A
4	1	610467	MODULAR MTR CONTROL ELECT VLV	33	1	618704	1 5/8MJIC-90-1 7/8MOR LBO
5	1	606090	BRAND HYD VALVE, 2-SECT SER 36	34	1	618476	1 5/8MJIC-90-1 5/16MOR LBO
6	4	470114	BREATHER FILTER VENT, 1/4 NPT	35	4	614747	.025 ELBOW ASSY, 9/16MOR 90D
7	4	620810	LIFT CYL ASSY, DETASSELER	36	1	615730	04C1T-06FJX-06FJX-150 H/A
8	2	620845	BOOM HINGE FOLD CYL ASSY	37	16	618327	3/4MJIC-7/8MOR ADPTR
9	4	618343	3/8 HOSE BARB-90-9/16MOR	38	1	616040	04C1T-06FJX-06FJX-67 H/A
10	1	606019	HYD RETURN MANIFOLD	39	1	614077	04C1T-06FJX-06FJX-88 H/A
11	1	616171	20C12-20FJX-20FJX-24 H/A	40	1	611246	04C1T-06FJX-06FJX-174 H/A
12	8	618119	9/16MJIC-90-9/16MOR LBO	41	1	614152	04C1T-06FJX-06FJX-114 H/A
13	2	618669	3/4FJIC SWIV-3/4MOR ADPTR	42	1	614746	08C1T-08FJX-08FJX-228 H/A
14	1	618494	3/4MOR RUN TEE-3/4MJIC	43	1	614384	08C1T-08FJX-08FJX-237 H/A
15	3	618115	9/16MJIC-90-3/4MOR LBO	44	1	614639	04C1T-06FJX-06FJX-126 H/A
16	5	618609	3/4MJIC-90-3/4FJIC SWIV LBO	45	2	616172	04C1T-06FJX-06FJX-60 H/A
17	1	618532	3/4FJIC CAP NUT	46	1	616168	08C1T-08FJX-08FJX-139 H/A
18	1	618594	7/8FJIC SWIV-7/8MOR ADPTR	47	4	616025	08C1T-08FJX-08FJX-50 H/A
19	1	611124	7/8MJIC-90-1/2MNPT LBO	48	1	616173	08C1T-08FJX-08FJX-157 H/A
20	1	618621	HYD QUICK CPLR, FEMALE, .50FNPS	49	1	616167	08C1T-08FJX-08FJX-96 H/A
21	1	618618	9/16MJIC-90-9/16FJIC SWIV LBO	50	1	614689	08C1T-08FJX-08FJX-120 H/A
22	1	605610	HYD FILTER, INLINE 90M 3/4FOR	51	1	616169	08C1T-08FJX-08FJX-146 H/A
23	1	618183	3/4MJIC-90-7/8MOR LBO	52	1	614690	08C1T-08FJX-08FJX-192 H/A
24	1	618622	HYD QUICK CPLR, MALE, .50FNPS	53	1	618310	9/16MJIC-7/8MOR ADPTR
25	1	618686	HYD QUICK CPLR, FEMALE 1.00UNF	54	4	601420	HOSE, 3/8 X 48 CLEAR VINYL
26	1	618687	HYD QUICK CPLR, MALE 1.00UNF	55	4	783306	1/4 FNPT X 3/8 HOSE BARB, BRS
27	1	618321	1 5/16MOR UNION	56	2	618709	9/16MJIC-90-3/4MOR EX LG LBO
28	1	618471	1 5/8MJIC-1 5/16MOR ADPTR	57	1	618241	3/4MJIC-90-3/4MOR LBO
29	1	618683	1 5/8MOR-1 5/8FJIC SWIV ADPTR	58	1	618623	3/4FJIC-SWIV-1/2MNPT

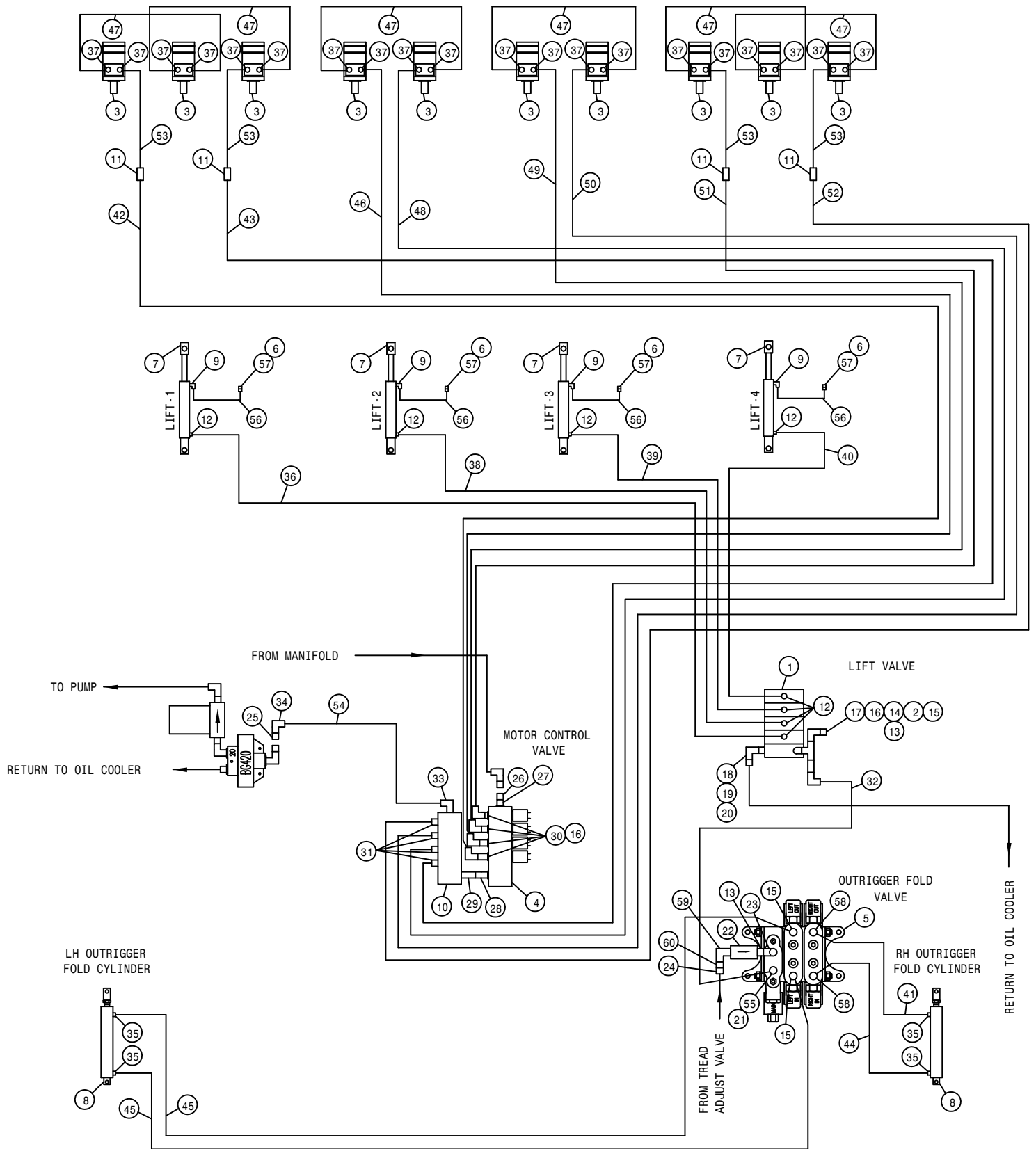

STS COMBO 10R QUAD HYD SCHEM 02
REFERENCE DRAWING NO. 498667

DET.	QTY	PART NO.	DESCRIPTION	DET.	QTY	PART NO.	DESCRIPTION
1	1	610613	ELECT HYD STACT VLV, 4 SECT	31	4	611125	3/4MJIC-3/4MOR ADPTR
2	1	605610	HYD FILTER, INLINE 90M 3/4FOR	32	1	616077	04-451TC-06FJX-06FJX-18 H/A
3	10	610547	HYD MOTOR 4.5CI 1IN SHFT	33	1	618704	1 5/8MJIC-90-1 7/8MOR LBO
4	1	610467	MODULAR MTR CONTROL ELECT VLV	34	1	618476	1 5/8MJIC-90-1 5/16MOR LBO
5	1	606090	BRAND HYD VALVE, 2-SECT SER 36	35	4	614747	.025 ELBOW ASSY,9/16MOR 90D
6	4	470114	BREATHER FILTER VENT, 1/4 NPT	36	1	615730	04C1T-06FJX-06FJX-150 H/A
7	4	620810	LIFT CYL ASSY, DETASSELER	37	20	618327	3/4MJIC-7/8MOR ADPTR
8	2	620845	BOOM HINGE FOLD CYL ASSY	38	1	616040	04C1T-06FJX-06FJX-67 H/A
9	4	618343	3/8 HOSE BARB-90-9/16MOR	39	1	614077	04C1T-06FJX-06FJX-88 H/A
10	1	606019	HYD RETURN MANIFOLD	40	1	611246	04C1T-06FJX-06FJX-174 H/A
11	4	618314	3/4MJIC UNION	41	1	614152	04C1T-06FJX-06FJX-114 H/A
12	8	618119	9/16MJIC-90-9/16MOR LBO	42	1	614746	08C1T-08FJX-08FJX-228 H/A
13	2	618669	3/4FJIC SWIV-3/4MOR ADPTR	43	1	614384	08C1T-08FJX-08FJX-237 H/A
14	1	618494	3/4MOR RUN TEE-3/4MJIC	44	1	614639	04C1T-06FJX-06FJX-126 H/A
15	3	618115	9/16MJIC-90-3/4MOR LBO	45	2	616172	04C1T-06FJX-06FJX-60 H/A
16	5	618609	3/4MJIC-90-3/4FJIC SWIV LBO	46	1	616168	08C1T-08FJX-08FJX-139 H/A
17	1	618532	3/4FJIC CAP NUT	47	6	616025	08C1T-08FJX-08FJX-50 H/A
18	1	618594	7/8FJIC SWIV-7/8MOR ADPTR	48	1	616173	08C1T-08FJX-08FJX-157 H/A
19	1	611124	7/8MJIC-90-1/2MNPT LBO	49	1	616167	08C1T-08FJX-08FJX-96 H/A
20	1	618621	HYD QUICK CPLR,FEMALE,.50FNPS	50	1	614689	08C1T-08FJX-08FJX-120 H/A
21	1	618618	9/16MJIC-90-9/16FJIC SWIV LBO	51	1	616169	08C1T-08FJX-08FJX-146 H/A
22	1	605610	HYD FILTER, INLINE 90M 3/4FOR	52	1	614690	08C1T-08FJX-08FJX-192 H/A
23	1	618183	3/4MJIC-90-7/8MOR LBO	53	4	615385	08C1T-08FJX-08FJX-29 H/A
24	1	618622	HYD QUICK CPLR, MALE, .50FNPS	54	1	616171	20C12-20FJX-20FJX-24 H/A
25	1	618686	HYD QUICK CPLR,FEMALE 1.00UNF	55	1	618310	9/16MJIC-7/8MOR ADPTR
26	1	618687	HYD QUICK CPLR, MALE 1.00UNF	56	4	601420	HOSE, 3/8 X 48 CLEAR VINYL
27	1	618321	1 5/16MOR UNION	57	4	783306	1/4 FNPT X 3/8 HOSE BARB, BRS
28	1	618471	1 5/8MJIC-1 5/16MOR ADPTR	58	2	618709	9/16MJIC-90-3/4MOR EX LG LBO
29	1	618683	1 5/8MOR-1 5/8FJIC SWIV ADPTR	59	1	618241	3/4MJIC-90-3/4MOR LBO
30	4	618469	3/4MJIC-1 1/16MOR ADPTR	60	1	618623	3/4FJIC-SWIV-1/2MNPT

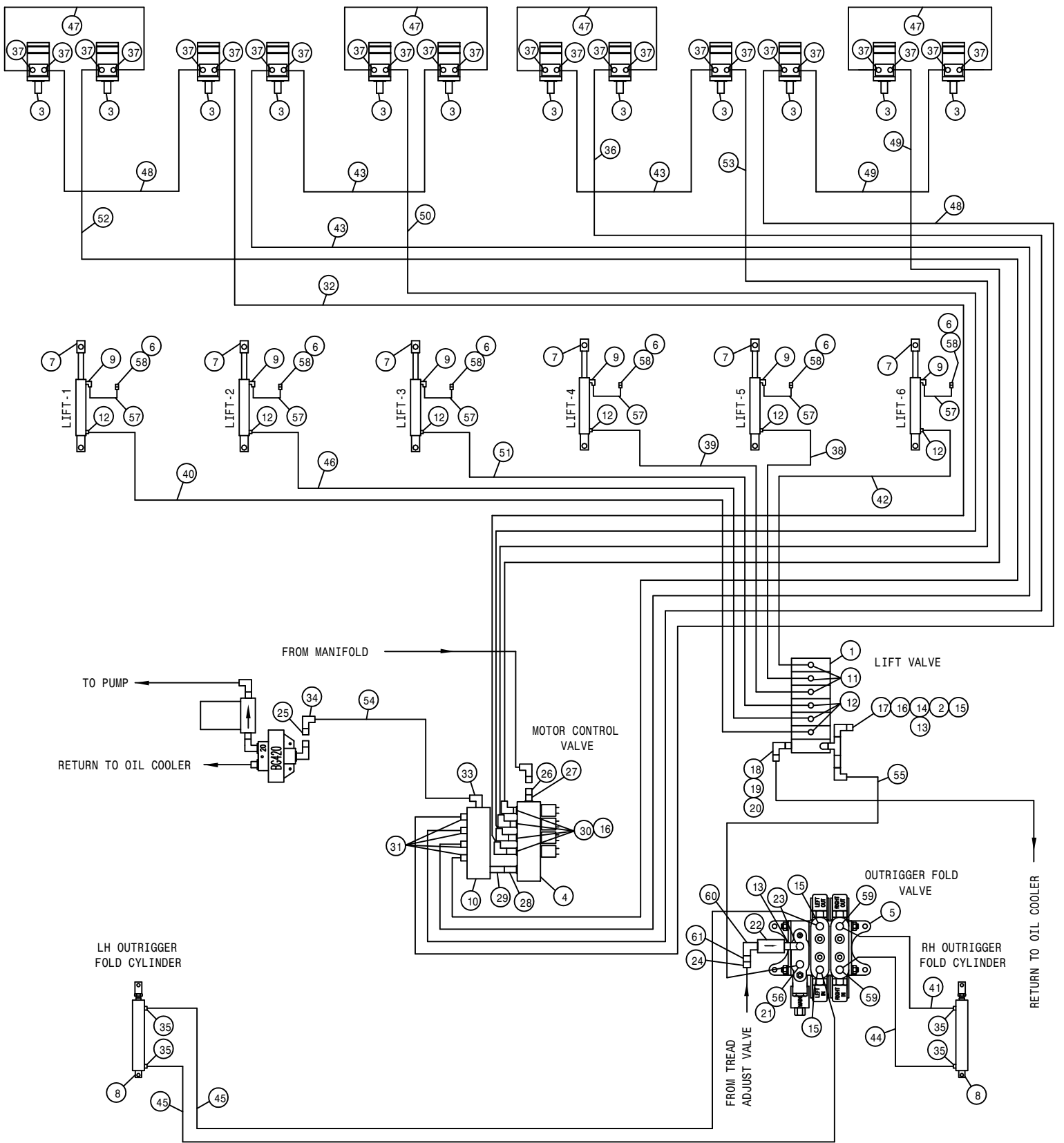

STS COMBO 12R QUAD HYD SCHEM 02
 REFERENCE DRAWING NO. 498668

DET.	QTY	PART NO.	DESCRIPTION	DET.	QTY	PART NO.	DESCRIPTION	
1	1	610615	ELECT HYD STACT VLV, 6 SECT	32	1	614746	08C1T-08FJX-08FJX-228	H/A
2	1	605610	HYD FILTER, INLINE 90M 3/4FOR	33	1	618704	1 5/8MJIC-90-1 7/8MOR LBO	
3	12	610547	HYD MOTOR 4.5CI 1IN SHFT	34	1	618476	1 5/8MJIC-90-1 5/16MOR LBO	
4	1	610467	MODULAR MTR CONTROL ELECT VLV	35	4	614747	.025 ELBOW ASSY, 9/16MOR 90D	
5	1	606090	BRAND HYD VALVE, 2-SECT SER 36	36	1	616167	08C1T-08FJX-08FJX-96	H/A
6	6	470114	BREATHER FILTER VENT, 1/4 NPT	37	24	618327	3/4MJIC-7/8MOR ADPTR	
7	6	620810	LIFT CYL ASSY, DETASSELER	38	1	611246	04C1T-06FJX-06FJX-174	H/A
8	2	620845	BOOM HINGE FOLD CYL ASSY	39	1	614077	04C1T-06FJX-06FJX-88	H/A
9	6	618343	3/8 HOSE BARB-90-9/16MOR	40	1	614100	04C1T-06FJX-06FJX-211	H/A
10	1	606019	HYD RETURN MANIFOLD	41	1	614152	04C1T-06FJX-06FJX-114	H/A
11	3	618126	9/16MJIC-9/16MOR ADPTR	42	1	614377	04C1T-06FJX-06FJX-258	H/A
12	9	618119	9/16MJIC-90-9/16MOR LBO	43	3	614384	08C1T-08FJX-08FJX-237	H/A
13	2	618669	3/4FJIC SWIV-3/4MOR ADPTR	44	1	614639	04C1T-06FJX-06FJX-126	H/A
14	1	618494	3/4MOR RUN TEE-3/4MJIC	45	2	616172	04C1T-06FJX-06FJX-60	H/A
15	3	618115	9/16MJIC-90-3/4MOR LBO	46	1	615730	04C1T-06FJX-06FJX-150	H/A
16	5	618609	3/4MJIC-90-3/4FJIC SWIV LBO	47	4	616025	08C1T-08FJX-08FJX-50	H/A
17	1	618532	3/4FJIC CAP NUT	48	2	614690	08C1T-08FJX-08FJX-192	H/A
18	1	618594	7/8FJIC SWIV-7/8MOR ADPTR	49	2	614691	08C1T-08FJX-08FJX-220	H/A
19	1	611124	7/8MJIC-90-1/2MNPT LBO	50	1	616168	08C1T-08FJX-08FJX-139	H/A
20	1	618621	HYD QUICK CPLR, FEMALE, .50FNPS	51	1	616040	04C1T-06FJX-06FJX-67	H/A
21	1	618618	9/16MJIC-90-9/16FJIC SWIV LBO	52	1	616170	08C1T-08FJX-08FJX-295	H/A
22	1	605610	HYD FILTER, INLINE 90M 3/4FOR	53	1	616169	08C1T-08FJX-08FJX-146	H/A
23	1	618183	3/4MJIC-90-7/8MOR LBO	54	1	616171	20C12-20FJX-20FJX-24	H/A
24	1	618622	HYD QUICK CPLR, MALE, .50FNPS	55	1	616077	04-451TC-06FJX-06FJX-18	H/A
25	1	618686	HYD QUICK CPLR, FEMALE 1.00UNF	56	1	618310	9/16MJIC-7/8MOR ADPTR	
26	1	618687	HYD QUICK CPLR, MALE 1.00UNF	57	6	601420	HOSE, 3/8 X 48 CLEAR VINYL	
27	1	618321	1 5/16MOR UNION	58	6	783306	1/4 FNPT X 3/8 HOSE BARB, BRS	
28	1	618471	1 5/8MJIC-1 5/16MOR ADPTR	59	2	618709	9/16MJIC-90-3/4MOR EX LG LBO	
29	1	618683	1 5/8MOR-1 5/8FJIC SWIV ADPTR	60	1	618241	3/4MJIC-90-3/4MOR LBO	
30	4	618469	3/4MJIC-1 1/16MOR ADPTR	61	1	618623	3/4FJIC-SWIV-1/2MNPT	
31	4	611125	3/4MJIC-3/4MOR ADPTR					

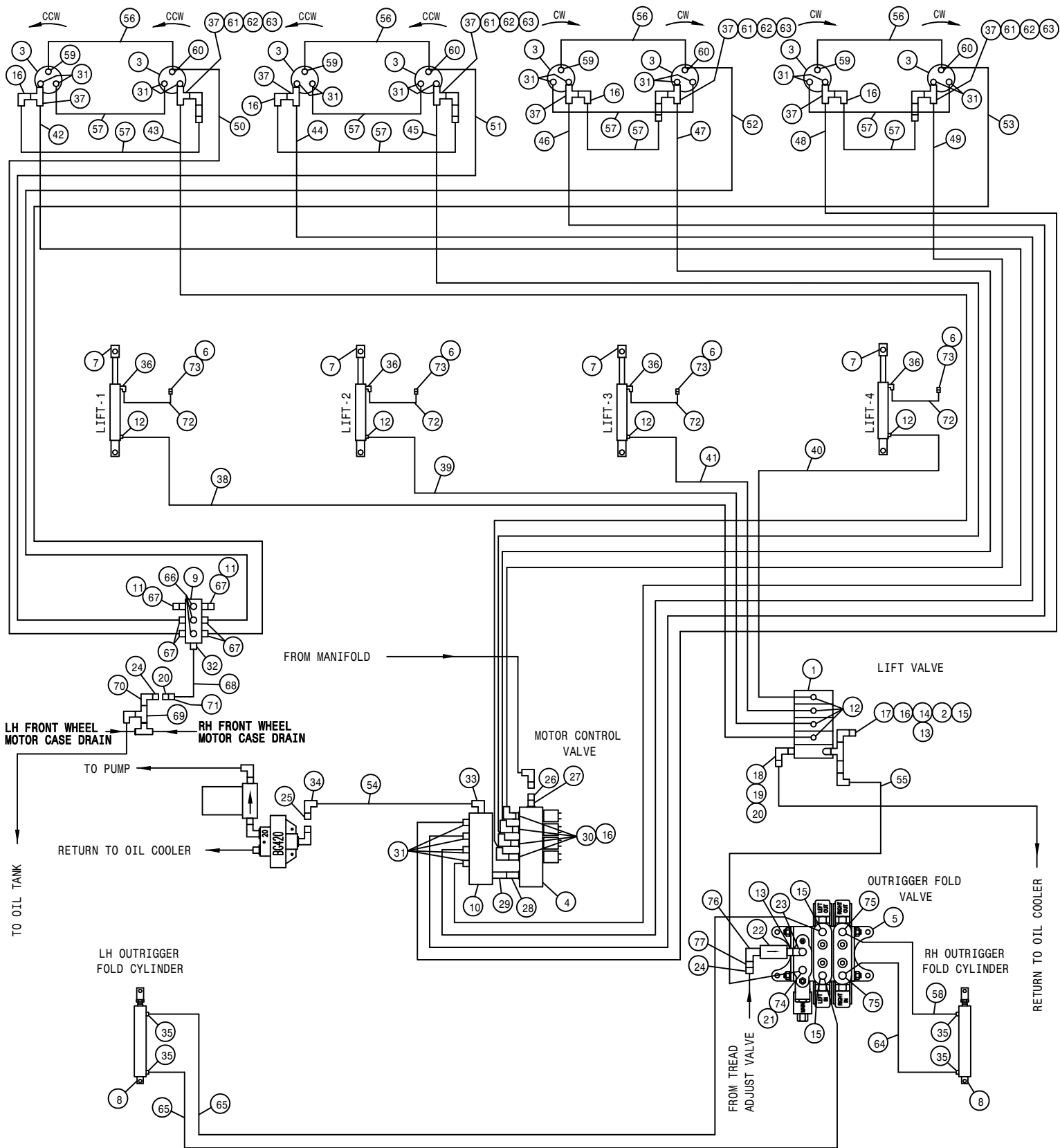

STS COMBO 8R CUTR HYD SCHEM 02
REFERENCE DRAWING NO. 498670

DET.	QTY	PART NO.	DESCRIPTION	DET.	QTY	PART NO.	DESCRIPTION		
1	1	610613	ELECT HYD STACT VLV, 4 SECT	40	1	611246	04C1T-06FJX-06FJX-174	H/A	
2	1	605610	HYD FILTER, INLINE 90M 3/4FOR	41	1	614077	04C1T-06FJX-06FJX-88	H/A	
3	8	610755	BARNES HYD MOTOR, D-SERIES 01	42	1	614746	08C1T-08FJX-08FJX-228	H/A	
4	1	610467	MODULAR MTR CONTROL ELECT VLV	43	1	614384	08C1T-08FJX-08FJX-237	H/A	
5	1	606090	BRAND HYD VALVE, 2-SECT SER 36	44	1	616168	08C1T-08FJX-08FJX-139	H/A	
6	4	470114	BREATHER FILTER VENT, 1/4 NPT	45	1	616173	08C1T-08FJX-08FJX-157	H/A	
7	4	620810	LIFT CYL ASSY, DETASSELER	46	1	616167	08C1T-08FJX-08FJX-96	H/A	
8	2	620845	BOOM HINGE FOLD CYL ASSY	47	1	614689	08C1T-08FJX-08FJX-120	H/A	
9	1	606021	HYD RETURN MANIF, 3/4FOR, 9-PORT	48	1	616169	08C1T-08FJX-08FJX-146	H/A	
10	1	606019	HYD RETURN MANIFOLD	49	1	614690	08C1T-08FJX-08FJX-192	H/A	
11	2	618531	9/16FJIC CAP NUT	50	1	614154	04C1T-06FJX-06FJX-221	H/A	
12	8	618119	9/16MJIC-90-9/16MOR LBO	51	1	614101	04C1T-06FJX-06FJX-133	H/A	
13	2	618669	3/4FJIC SWIV-3/4MOR ADPTR	52	1	615729	04C1T-06FJX-06FJX-84	H/A	
14	1	618494	3/4MOR RUN TEE-3/4MJIC	53	1	611262	04C1T-06FJX-06FJX-182	H/A	
15	3	618115	9/16MJIC-90-3/4MOR LBO	54	1	616171	20C12-20FJX-20FJX-24	H/A	
16	5	618609	3/4MJIC-90-3/4FJIC SWIV LBO	55	1	616077	04-451TC-06FJX-06FJX-18	H/A	
17	1	618532	3/4FJIC CAP NUT	56	4	611206	04C1T-06FJX-06FJX-66	H/A	
18	1	618594	7/8FJIC SWIV-7/8MOR ADPTR	57	8	614368	08C1T-08FJX-08FJX-60	H/A	
19	1	611124	7/8MJIC-90-1/2MNPT LBO	58	1	614152	04C1T-06FJX-06FJX-114	H/A	
20	2	618621	HYD QUICK CPLR, FEMALE, .50FNPS	59	4	618530	9/16MJIC-1/8MNPT ADPTR		
21	1	618618	9/16MJIC-90-9/16FJIC SWIV LBO	60	4	618546	1/8MNPT RUN TEE-9/16MJIC		
22	1	605610	HYD FILTER, INLINE 90M 3/4FOR	61	4	618620	3/4FJX-90-1/2MNPT ADPTR		
23	1	618183	3/4MJIC-90-7/8MOR LBO	62	4	690338	LINE CHECK VALVE HYD .50NPT		
24	2	618622	HYD QUICK CPLR, MALE, .50FNPS	63	4	611147	3/4MJIC-1/2MNPT ADPTR		
25	1	618686	HYD QUICK CPLR, FEMALE 1.00UNF	64	1	614639	04C1T-06FJX-06FJX-126	H/A	
26	1	618687	HYD QUICK CPLR, MALE 1.00UNF	65	2	616172	04C1T-06FJX-06FJX-60	H/A	
27	1	618321	1 5/16MOR UNION	66	1	611159	3/4MOR PLUG		
28	1	618471	1 5/8MJIC-1 5/16MOR ADPTR	67	6	618109	9/16MJIC-3/4MOR ADPTR		
29	1	618683	1 5/8MOR-1 5/8FJIC SWIV ADPTR	68	1	616005	12-451TC-12FJX-12FJX-17	H/A	
30	4	618469	3/4MJIC-1 1/16MOR ADPTR	69	1	618333	7/8FJIC SW RUN TEE-7/8MJIC		
31	20	611125	3/4MJIC-3/4MOR ADPTR	70	1	618710	7/8FJX-90-1/2MNPT ADPTR		
32	1	611127	1 1/16MJIC-1 1/16MOR ADPTR	71	1	618273	1 1/16MJIC-1/2MNPT ADPTR		
33	1	618704	1 5/8MJIC-90-1 7/8MOR LBO	72	4	601420	HOSE, 3/8 X 48 CLEAR VINYL		
34	1	618476	1 5/8MJIC-90-1 5/16MOR LBO	73	4	783306	1/4 FNPT X 3/8 HOSE BARB, BRS		
35	4	614747	.025 ELBOW ASSY, 9/16MOR 90D	74	1	618310	9/16MJIC-7/8MOR ADPTR		
36	4	618343	3/8 HOSE BARB-90-9/16MOR	75	2	618709	9/16MJIC-90-3/4MOR EX LG LBO		
37	8	618451	3/4FJIC SW RUN TEE-3/4MJIC	76	1	618241	3/4MJIC-90-3/4MOR LBO		
38	1	615730	04C1T-06FJX-06FJX-150	H/A	77	1	618623	3/4FJIC-SWIV-1/2MNPT	
39	1	616040	04C1T-06FJX-06FJX-67	H/A					

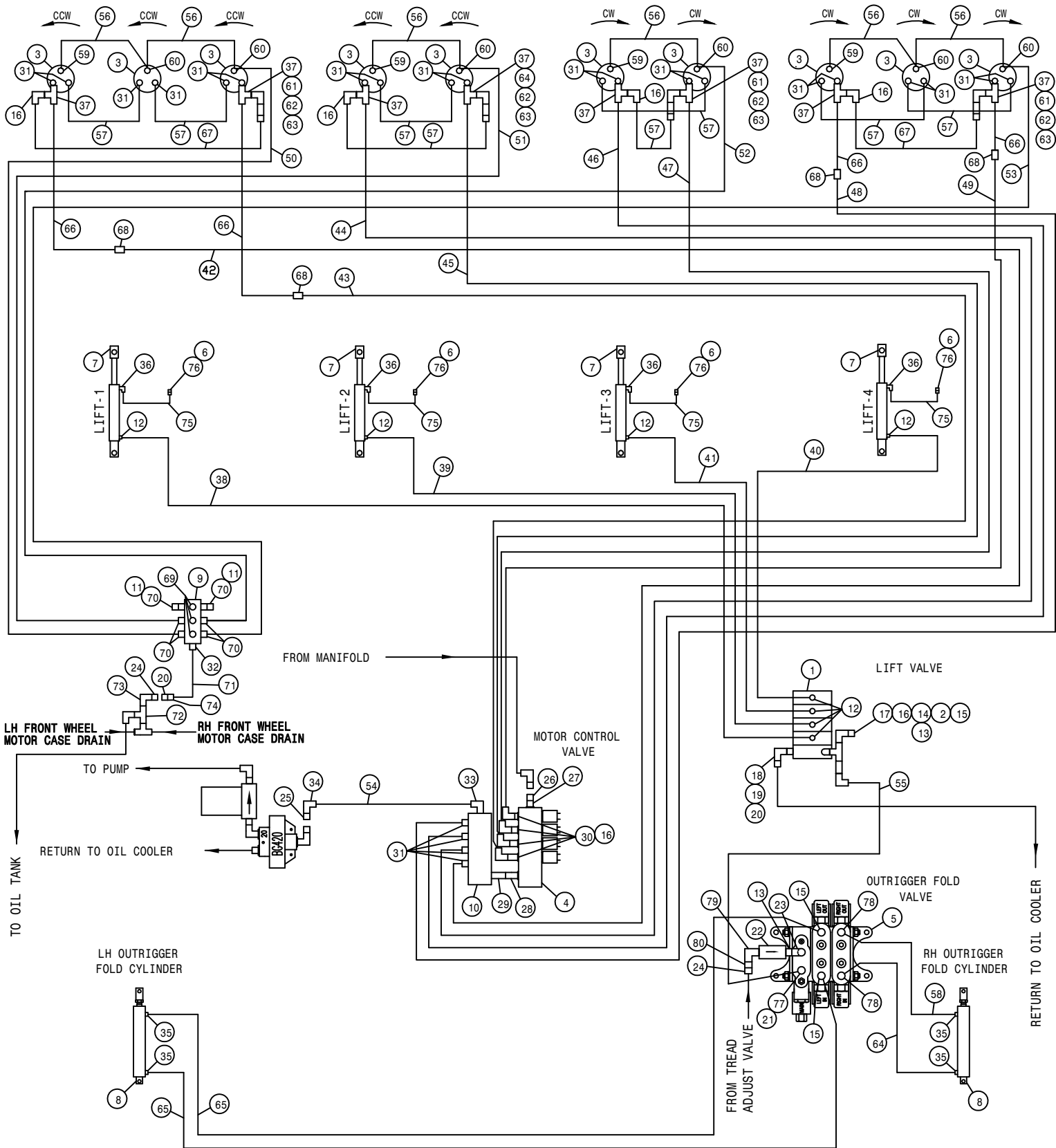

STS COMBO 10R CUTR HYD SCHEM 02
REFERENCE DRAWING NO. 498671

DET.	QTY	PART NO.	DESCRIPTION	DET.	QTY	PART NO.	DESCRIPTION		
1	1	610613	ELECT HYD STACT VLV, 4 SECT	41	1	614077	04C1T-06FJX-06FJX-88	H/A	
2	1	605610	HYD FILTER, INLINE 90M 3/4FOR	42	1	614746	08C1T-08FJX-08FJX-228	H/A	
3	10	610755	BARNES HYD MOTOR, D-SERIES 01	43	1	614384	08C1T-08FJX-08FJX-237	H/A	
4	1	610467	MODULAR MTR CONTROL ELECT VLV	44	1	616168	08C1T-08FJX-08FJX-139	H/A	
5	1	606090	BRAND HYD VALVE, 2-SECT SER 36	45	1	616173	08C1T-08FJX-08FJX-157	H/A	
6	4	470114	BREATHER FILTER VENT, 1/4 NPT	46	1	616167	08C1T-08FJX-08FJX-96	H/A	
7	4	620810	LIFT CYL ASSY, DETASSELER	47	1	614689	08C1T-08FJX-08FJX-120	H/A	
8	2	620845	BOOM HINGE FOLD CYL ASSY	48	1	616169	08C1T-08FJX-08FJX-146	H/A	
9	1	606021	HYD RETURN MANIF, 3/4FOR, 9-PORT	49	1	614690	08C1T-08FJX-08FJX-192	H/A	
10	1	606019	HYD RETURN MANIFOLD	50	1	614154	04C1T-06FJX-06FJX-221	H/A	
11	2	618531	9/16FJIC CAP NUT	51	1	614101	04C1T-06FJX-06FJX-133	H/A	
12	8	618119	9/16MJIC-90-9/16MOR LBO	52	1	615729	04C1T-06FJX-06FJX-84	H/A	
13	2	618669	3/4FJIC SWIV-3/4MOR ADPTR	53	1	611262	04C1T-06FJX-06FJX-182	H/A	
14	1	618494	3/4MOR RUN TEE-3/4MJIC	54	1	616171	20C12-20FJX-20FJX-24	H/A	
15	3	618115	9/16MJIC-90-3/4MOR LBO	55	1	616077	04-451TC-06FJX-06FJX-18	H/A	
16	5	618609	3/4MJIC-90-3/4FJIC SWIV LBO	56	6	611206	04C1T-06FJX-06FJX-66	H/A	
17	1	618532	3/4FJIC CAP NUT	57	8	614368	08C1T-08FJX-08FJX-60	H/A	
18	1	618594	7/8FJIC SWIV-7/8MOR ADPTR	58	1	614152	04C1T-06FJX-06FJX-114	H/A	
19	1	611124	7/8MJIC-90-1/2MNPT LBO	59	4	618530	9/16MJIC-1/8MNPT ADPTR		
20	2	618621	HYD QUICK CPLR, FEMALE, .50FNPS	60	6	618546	1/8MNPT RUN TEE-9/16MJIC		
21	1	618618	9/16MJIC-90-9/16FJIC SWIV LBO	61	4	618620	3/4FJX-90-1/2MNPT ADPTR		
22	1	605610	HYD FILTER, INLINE 90M 3/4FOR	62	4	690338	LINE CHECK VALVE HYD .50NPT		
23	1	618183	3/4MJIC-90-7/8MOR LBO	63	4	611147	3/4MJIC-1/2MNPT ADPTR		
24	2	618622	HYD QUICK CPLR, MALE, .50FNPS	64	1	614639	04C1T-06FJX-06FJX-126	H/A	
25	1	618686	HYD QUICK CPLR, FEMALE 1.00UNF	65	2	616172	04C1T-06FJX-06FJX-60	H/A	
26	1	618687	HYD QUICK CPLR, MALE 1.00UNF	66	4	615385	08C1T-08FJX-08FJX-29	H/A	
27	1	618321	1 5/16MOR UNION	67	2	616057	08C1T-08FJX-08FJX-88	H/A	
28	1	618471	1 5/8MJIC-1 5/16MOR ADPTR	68	4	618314	3/4MJIC UNION		
29	1	618683	1 5/8MOR-1 5/8FJIC SWIV ADPTR	69	3	611159	3/4MOR PLUG		
30	4	618469	3/4MJIC-1 1/16MOR ADPTR	70	6	618109	9/16MJIC-3/4MOR ADPTR		
31	20	611125	3/4MJIC-3/4MOR ADPTR	71	1	616005	12-451TC-12FJX-12FJX-17	H/A	
32	1	611127	1 1/16MJIC-1 1/16MOR ADPTR	72	1	618333	7/8FJIC SW RUN TEE-7/8MJIC		
33	1	618704	1 5/8MJIC-90-1 7/8MOR LBO	73	1	618710	7/8FJX-90-1/2MNPT ADPTR		
34	1	618476	1 5/8MJIC-90-1 5/16MOR LBO	74	1	618273	1 1/16MJIC-1/2MNPT ADPTR		
35	4	614747	.025 ELBOW ASSY, 9/16MOR 90D	75	4	601420	HOSE, 3/8 X 48 CLEAR VINYL		
36	4	618343	3/8 HOSE BARB-90-9/16MOR	76	4	783306	1/4 FNPT X 3/8 HOSE BARB, BRS		
37	8	618451	3/4FJIC SW RUN TEE-3/4MJIC	77	1	618310	9/16MJIC-7/8MOR ADPTR		
38	1	615730	04C1T-06FJX-06FJX-150	H/A	78	2	618709	9/16MJIC-90-3/4MOR EX LG LBO	
39	1	616040	04C1T-06FJX-06FJX-67	H/A	79	1	618241	3/4MJIC-90-3/4MOR LBO	
40	1	611246	04C1T-06FJX-06FJX-174	H/A	80	1	618623	3/4FJIC-SWIV-1/2MNPT	

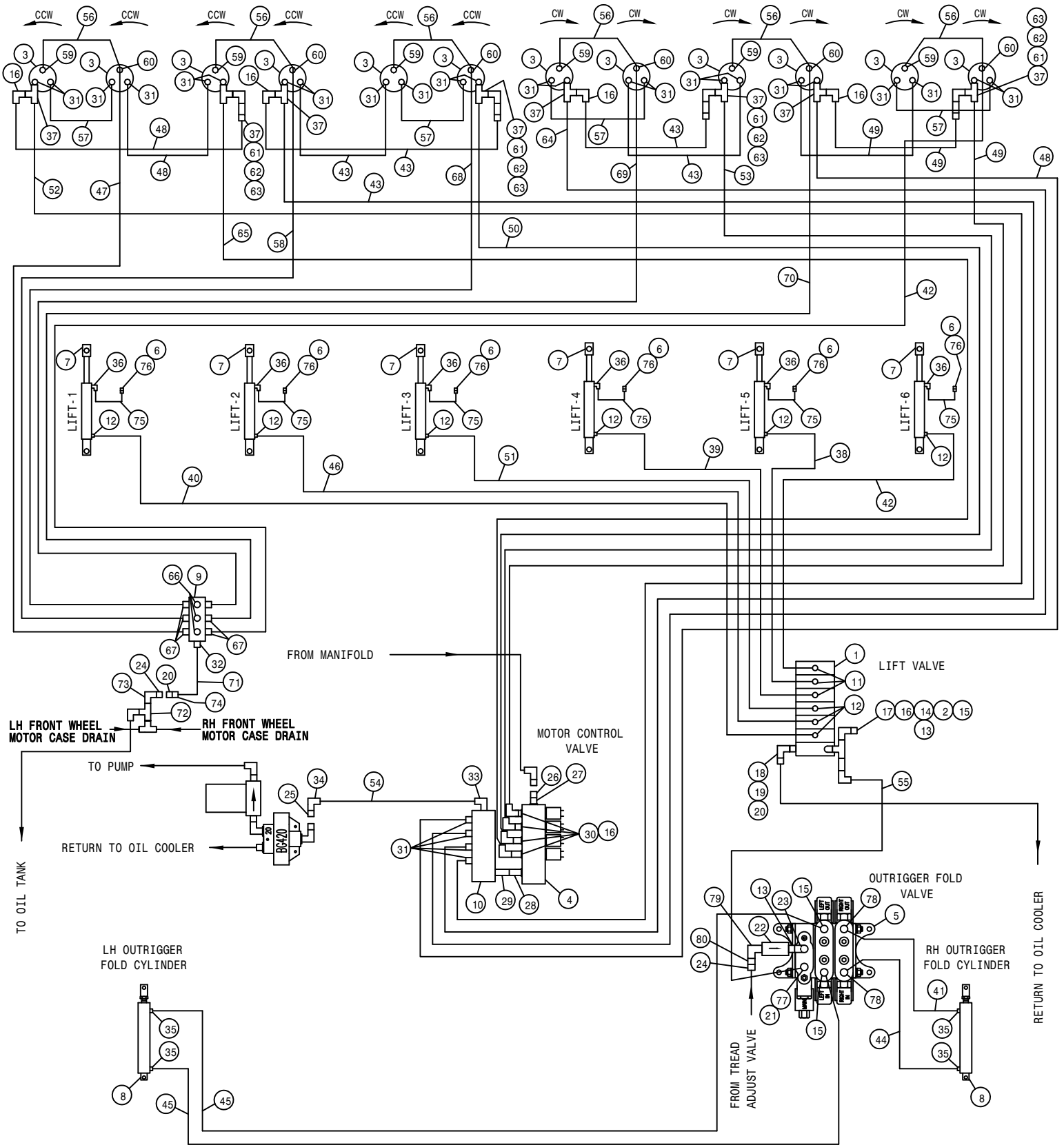

STS COMBO 12R CUTR HYD SCHEM 02
REFERENCE DRAWING NO. 498672

DET.	QTY	PART NO.	DESCRIPTION	DET.	QTY	PART NO.	DESCRIPTION		
1	1	610615	ELECT HYD STACT VLV, 6 SECT	41	1	614152	04C1T-06FJX-06FJX-114	H/A	
2	1	605610	HYD FILTER, INLINE 90M 3/4FOR	42	2	614377	04C1T-06FJX-06FJX-258	H/A	
3	12	610755	BARNES HYD MOTOR, D-SERIES 01	43	5	614384	08C1T-08FJX-08FJX-237	H/A	
4	1	610467	MODULAR MTR CONTROL ELECT VLV	44	1	614639	04C1T-06FJX-06FJX-126	H/A	
5	1	606090	BRAND HYD VALVE, 2-SECT SER 36	45	2	616172	04C1T-06FJX-06FJX-60	H/A	
6	6	470114	BREATHER FILTER VENT, 1/4 NPT	46	1	615730	04C1T-06FJX-06FJX-150	H/A	
7	6	620810	LIFT CYL ASSY, DETASSELER	47	1	615731	04C1T-06FJX-06FJX-290	H/A	
8	2	620845	BOOM HINGE FOLD CYL ASSY	48	3	614690	08C1T-08FJX-08FJX-192	H/A	
9	1	606021	HYD RETURN MANIF, 3/4FOR, 9-PORT	49	3	614691	08C1T-08FJX-08FJX-220	H/A	
10	1	606019	HYD RETURN MANIFOLD	50	1	616168	08C1T-08FJX-08FJX-139	H/A	
11	3	618126	9/16MJIC-9/16MOR ADPTR	51	1	616040	04C1T-06FJX-06FJX-67	H/A	
12	9	618119	9/16MJIC-90-9/16MOR LBO	52	1	616170	08C1T-08FJX-08FJX-295	H/A	
13	2	618669	3/4FJIC SWIV-3/4MOR ADPTR	53	1	616169	08C1T-08FJX-08FJX-146	H/A	
14	1	618494	3/4MOR RUN TEE-3/4MJIC	54	1	616171	20C12-20FJX-20FJX-24	H/A	
15	3	618115	9/16MJIC-90-3/4MOR LBO	55	1	616077	04-451TC-06FJX-06FJX-18	H/A	
16	9	618609	3/4MJIC-90-3/4FJIC SWIV LBO	56	6	611206	04C1T-06FJX-06FJX-66	H/A	
17	1	618532	3/4FJIC CAP NUT	57	4	614368	08C1T-08FJX-08FJX-60	H/A	
18	1	618594	7/8FJIC SWIV-7/8MOR ADPTR	58	1	614154	04C1T-06FJX-06FJX-221	H/A	
19	1	611124	7/8MJIC-90-1/2MNPT LBO	59	6	618530	9/16MJIC-1/8MNPT ADPTR		
20	2	618621	HYD QUICK CPLR, FEMALE, .50FNPS	60	6	618546	1/8MNPT RUN TEE-9/16MJIC		
21	1	618618	9/16MJIC-90-9/16FJIC SWIV LBO	61	4	618620	3/4FJX-90-1/2MNPT ADPTR		
22	1	605610	HYD FILTER, INLINE 90M 3/4FOR	62	4	690338	LINE CHECK VALVE HYD .50NPT		
23	1	618183	3/4MJIC-90-7/8MOR LBO	63	4	611147	3/4MJIC-1/2MNPT ADPTR		
24	2	618622	HYD QUICK CPLR, MALE, .50FNPS	64	1	616167	08C1T-08FJX-08FJX-96	H/A	
25	1	618686	HYD QUICK CPLR, FEMALE 1.00UNF	65	1	614746	08C1T-08FJX-08FJX-228	H/A	
26	1	618687	HYD QUICK CPLR, MALE 1.00UNF	66	3	611159	3/4MOR PLUG		
27	1	618321	1 5/16MOR UNION	67	6	618109	9/16MJIC-3/4MOR ADPTR		
28	1	618471	1 5/8MJIC-1 5/16MOR ADPTR	68	1	614101	04C1T-06FJX-06FJX-133	H/A	
29	1	618683	1 5/8MOR-1 5/8FJIC SWIV ADPTR	69	1	615729	04C1T-06FJX-06FJX-84	H/A	
30	4	618469	3/4MJIC-1 1/16MOR ADPTR	70	1	611262	04C1T-06FJX-06FJX-182	H/A	
31	28	611125	3/4MJIC-3/4MOR ADPTR	71	1	616005	12-451TC-12FJX-12FJX-17	H/A	
32	1	611127	1 1/16MJIC-1 1/16MOR ADPTR	72	1	618333	7/8FJIC SW RUN TEE-7/8MJIC		
33	1	618704	1 5/8MJIC-90-1 7/8MOR LBO	73	1	618710	7/8FJX-90-1/2MNPT ADPTR		
34	1	618476	1 5/8MJIC-90-1 5/16MOR LBO	74	1	618273	1 1/16MJIC-1/2MNPT ADPTR		
35	4	614747	.025 ELBOW ASSY, 9/16MOR 90D	75	6	601420	HOSE, 3/8 X 48 CLEAR VINYL		
36	6	618343	3/8 HOSE BARB-90-9/16MOR	76	6	783306	1/4 FNPT X 3/8 HOSE BARB, BRS		
37	8	618451	3/4FJIC SW RUN TEE-3/4MJIC	77	1	618310	9/16MJIC-7/8MOR ADPTR		
38	1	611246	04C1T-06FJX-06FJX-174	H/A	78	2	618709	9/16MJIC-90-3/4MOR EX LG LBO	
39	1	614077	04C1T-06FJX-06FJX-88	H/A	79	1	618241	3/4MJIC-90-3/4MOR LBO	
40	1	614100	04C1T-06FJX-06FJX-211	H/A	80	1	618623	3/4FJIC-SWIV-1/2MNPT	

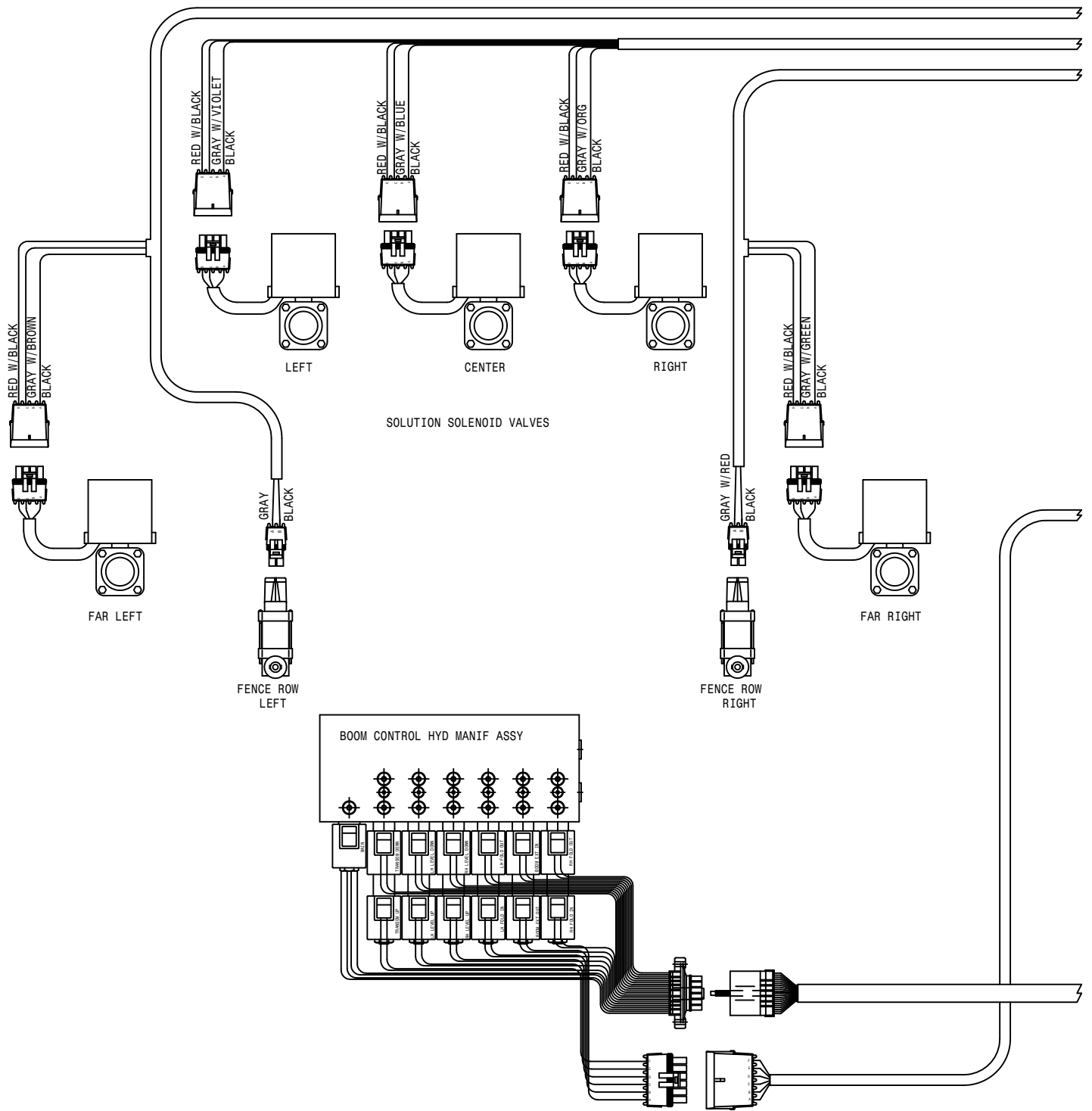

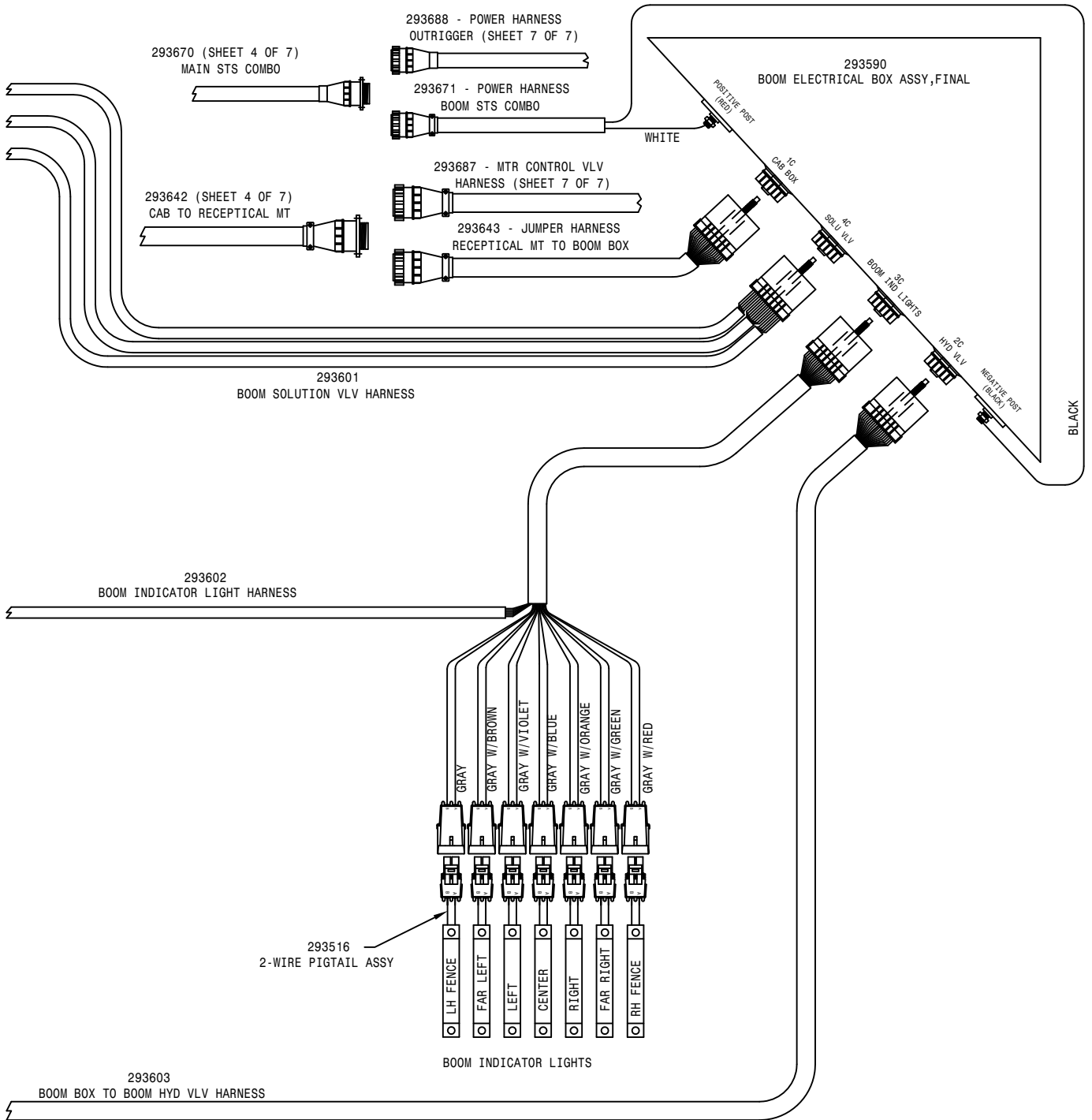

ST5 10 WIRING DIAGRAM 02
COMBO
SHEET 1 OF 7
REVISION DATE: 03-04-02
498638
01-16-02 TLM

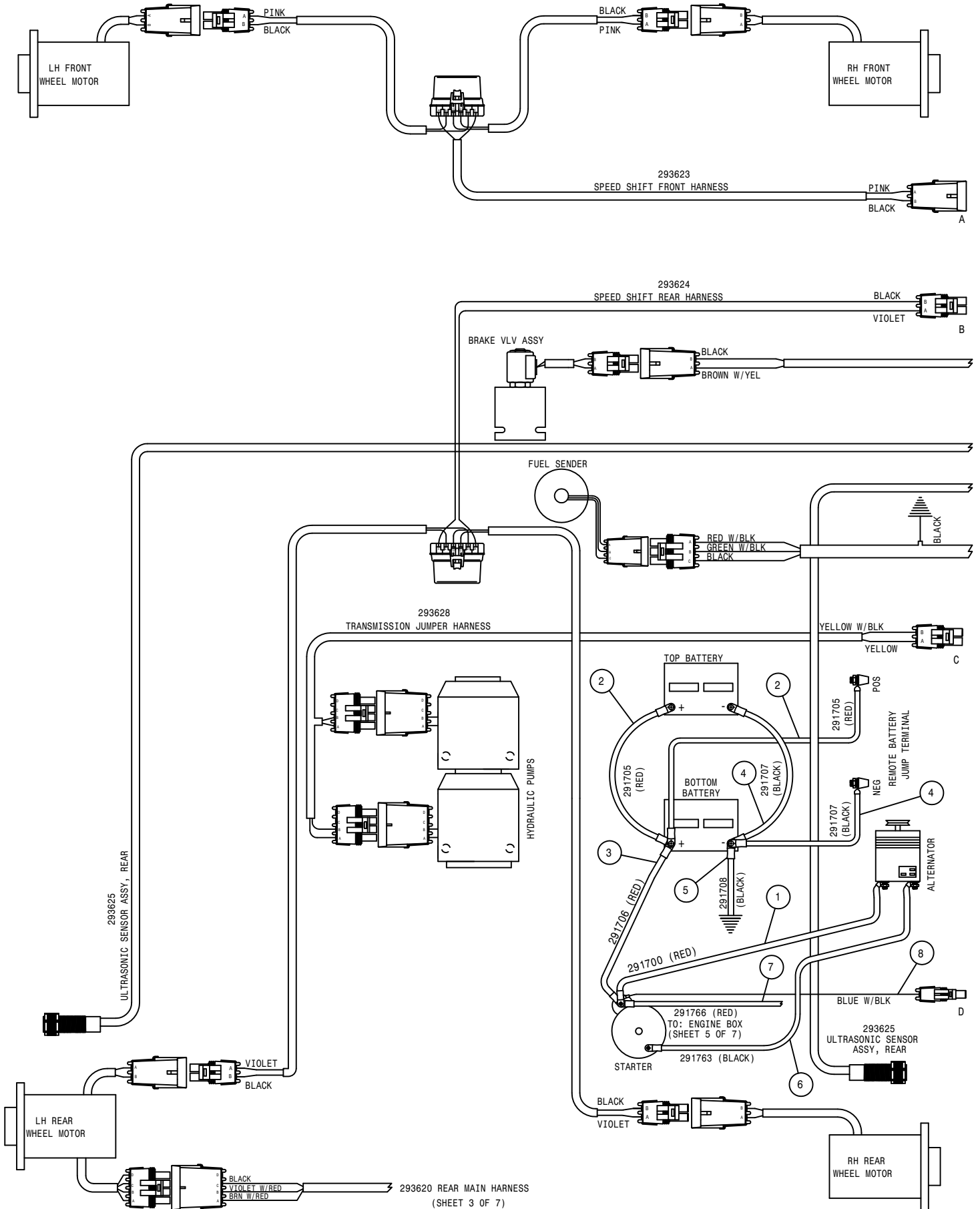

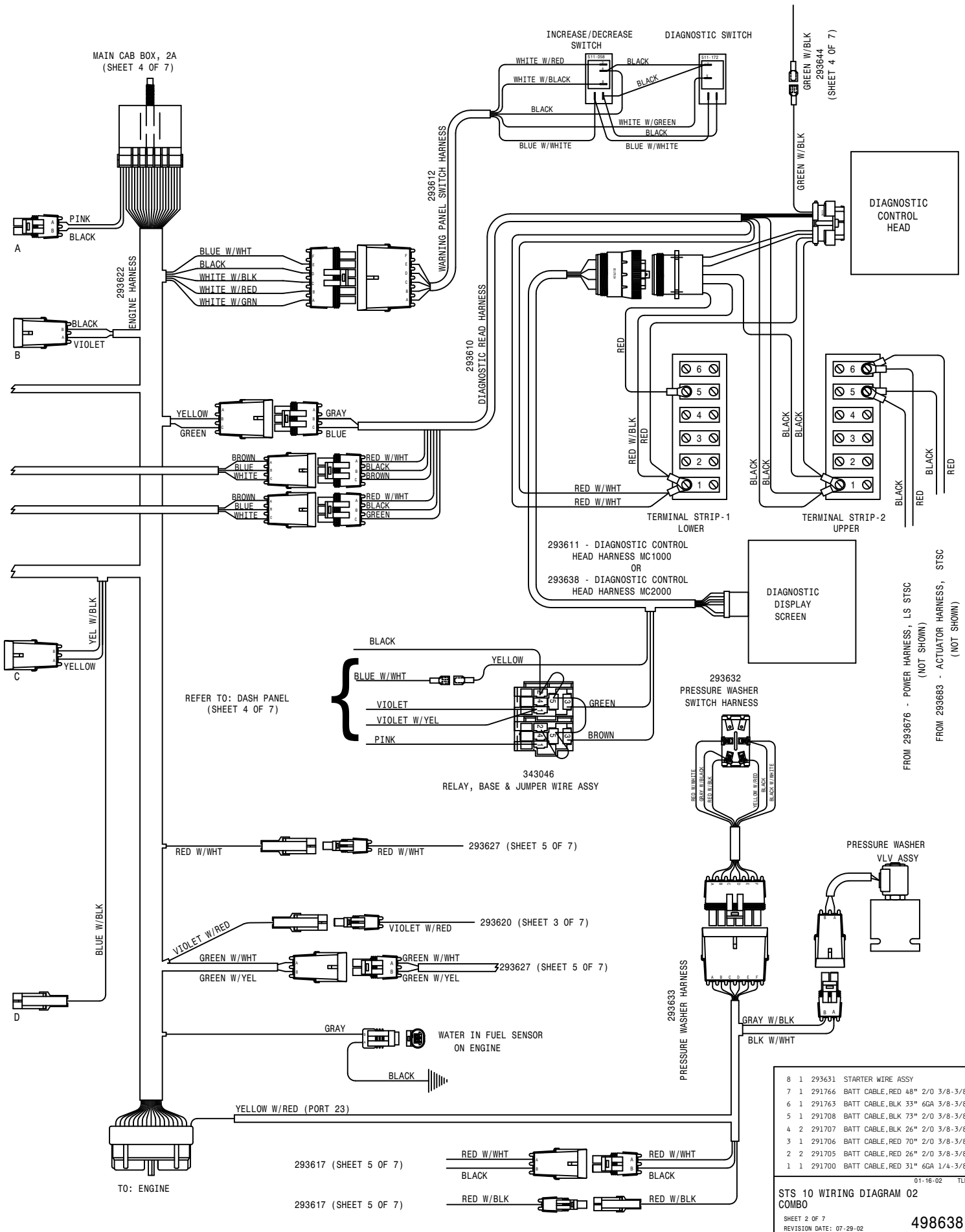

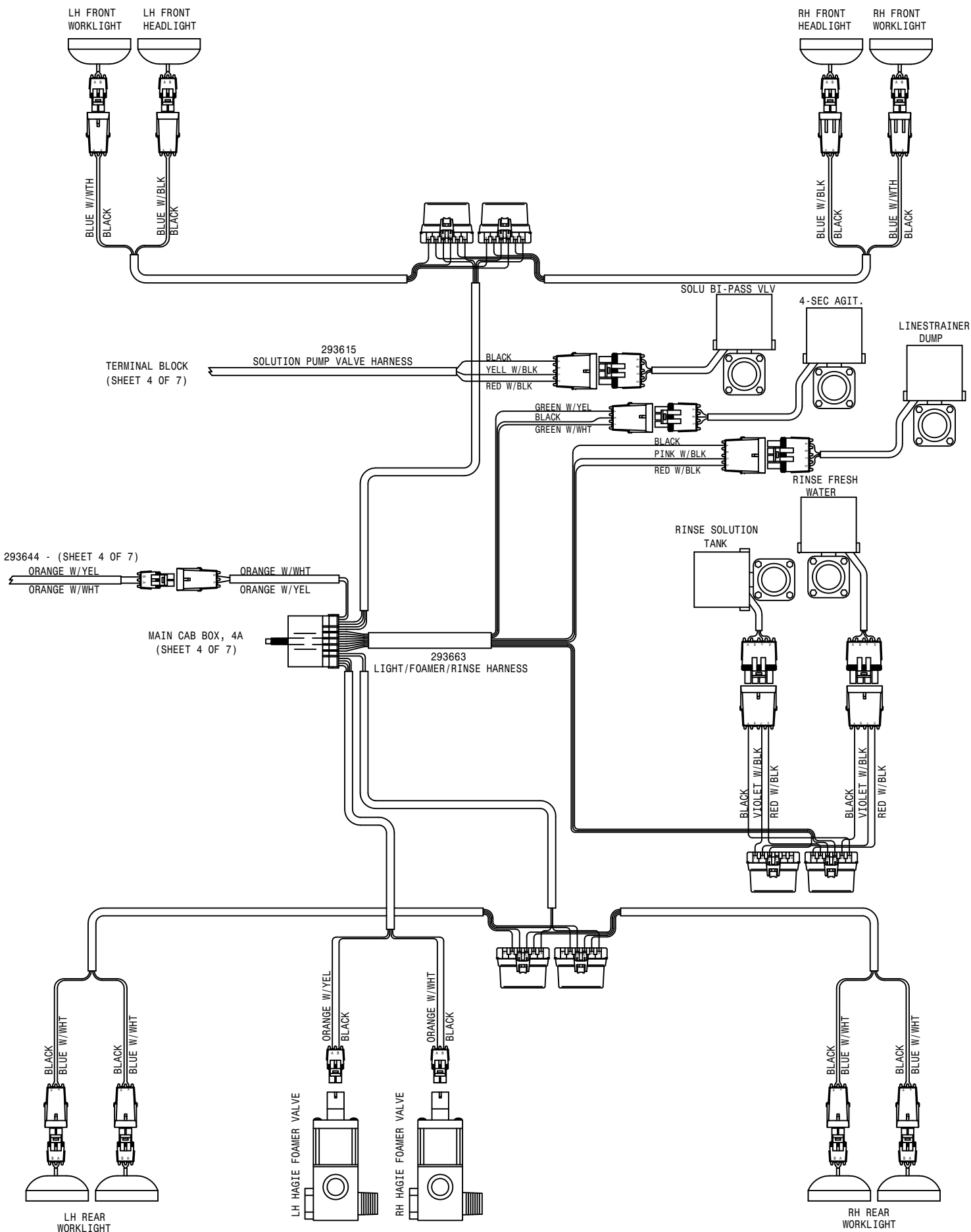

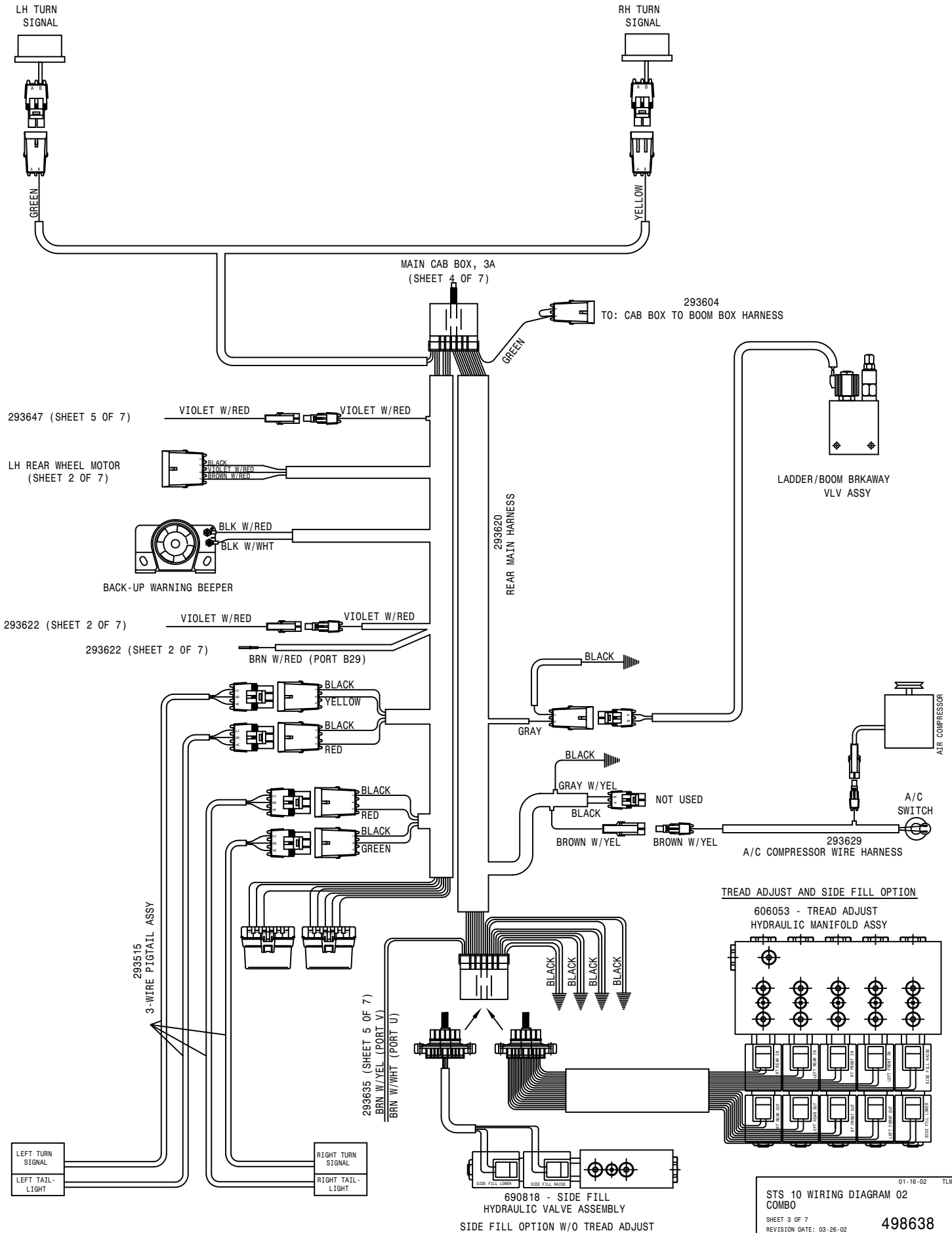

YELLOW
293638 (SHEET 2 OF 7)

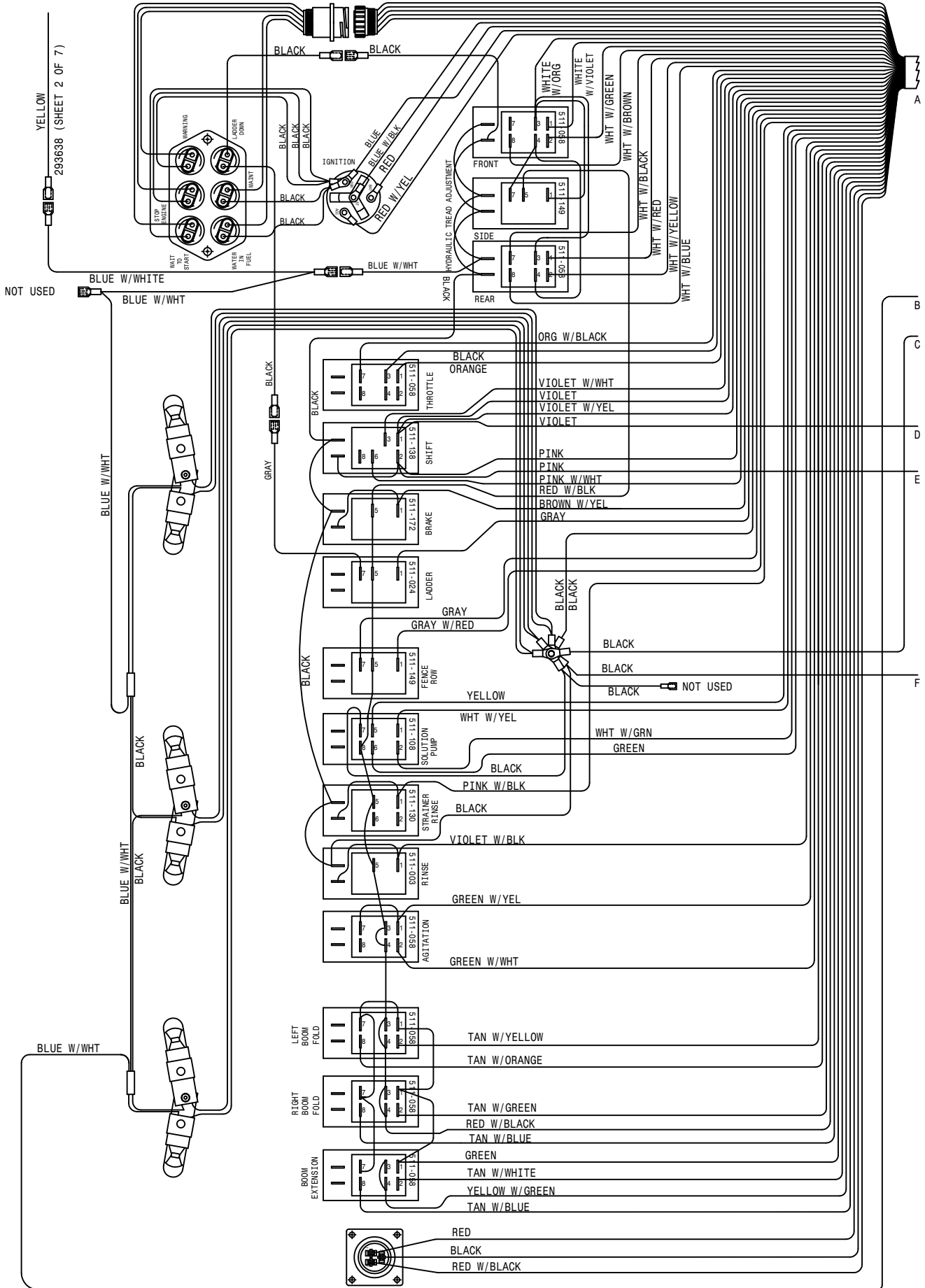

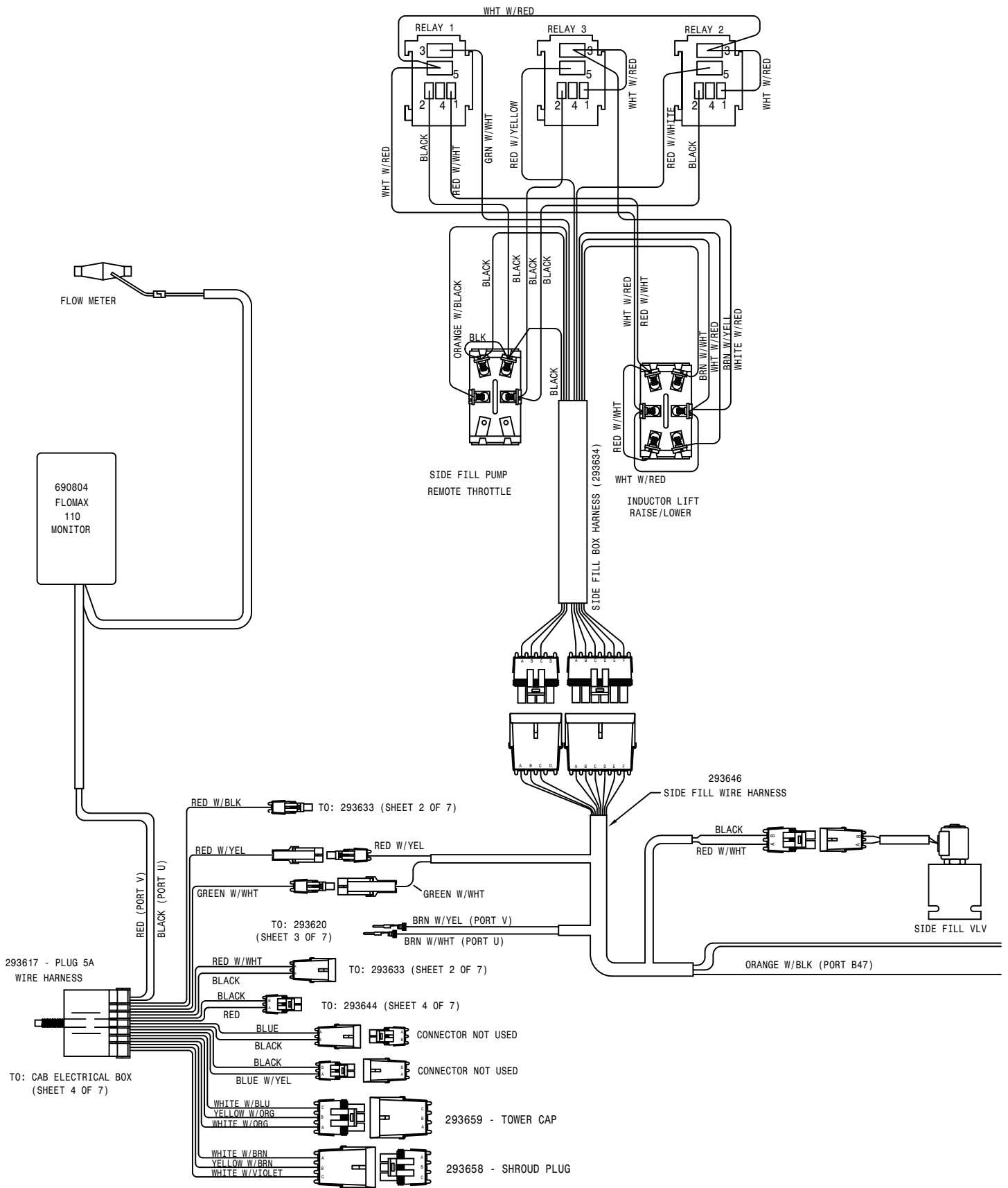

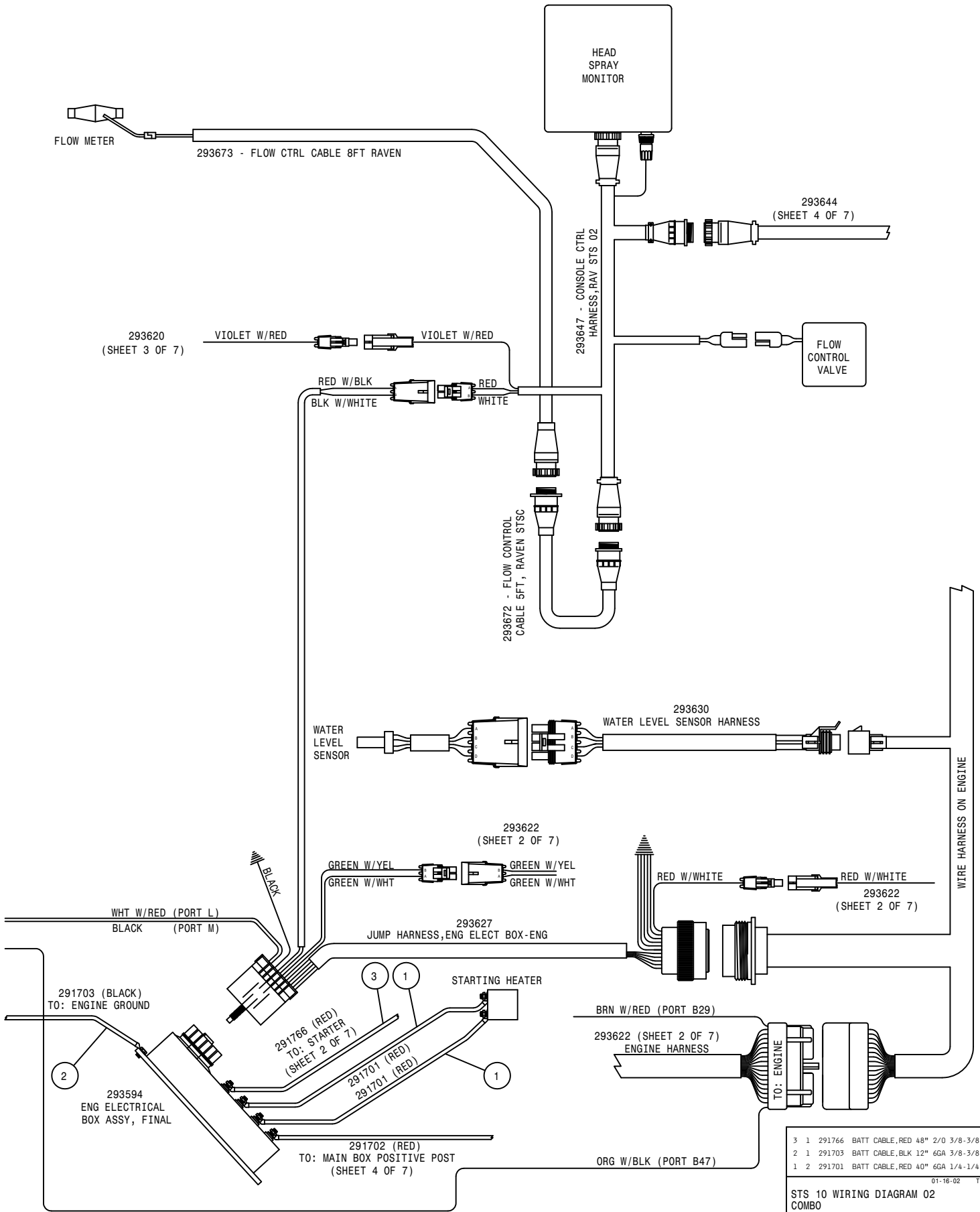

3	1	291766	BATT CABLE, RED 48" 2/0 3/8-3/8
2	1	291703	BATT CABLE, BLK 12" 6GA 3/8-3/8
1	2	291701	BATT CABLE, RED 40" 6GA 1/4-1/4
01-16-02 TLM			
STS 10 WIRING DIAGRAM 02 COMBO			
SHEET 5 OF 7			
REVISION DATE: 03-04-02			
			498638

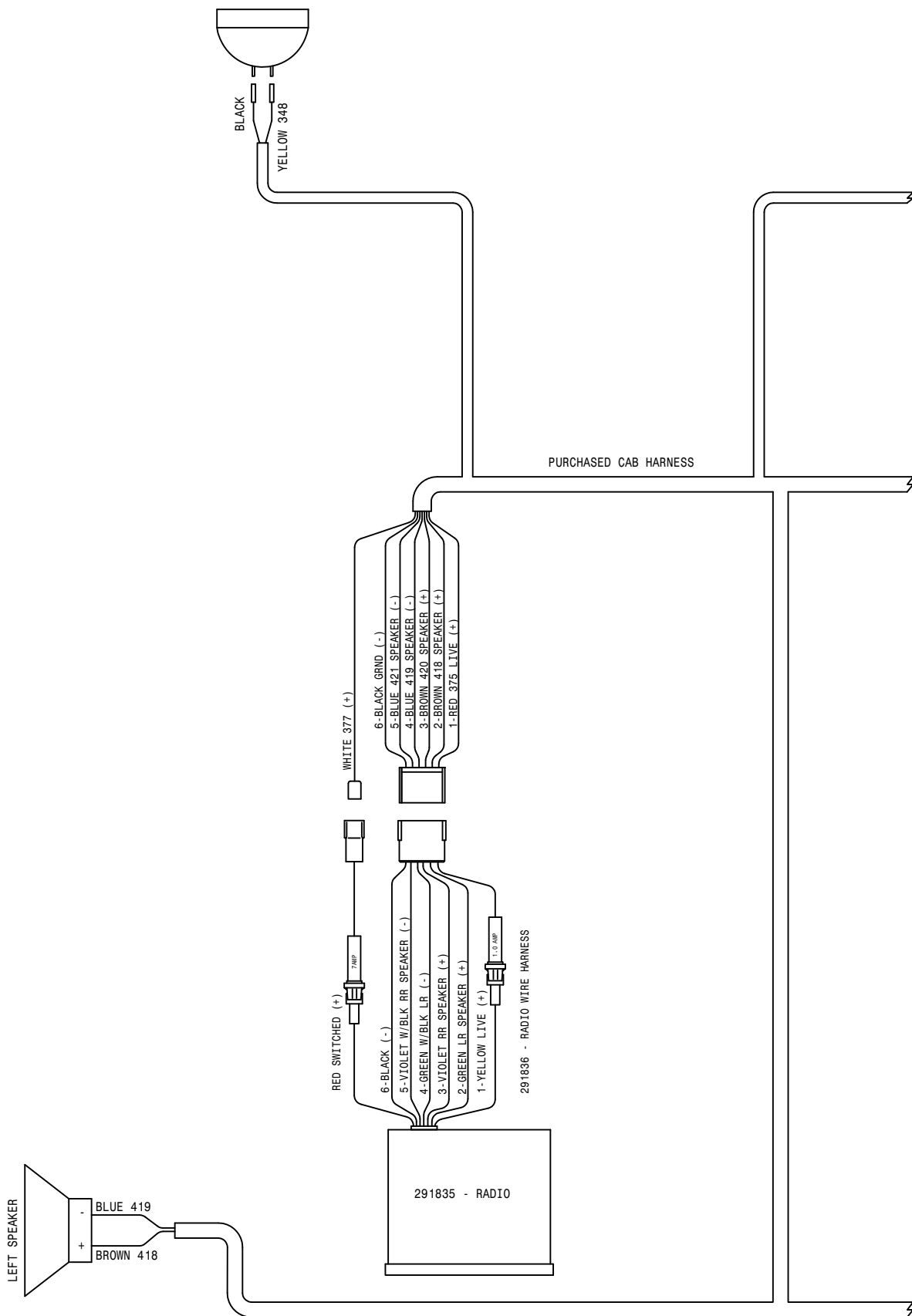

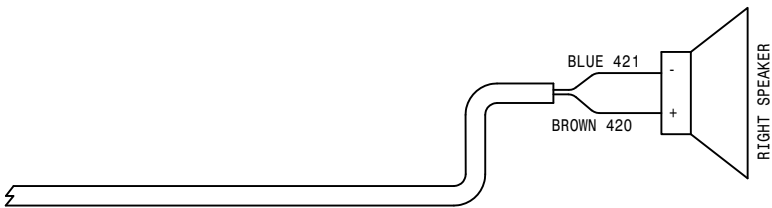
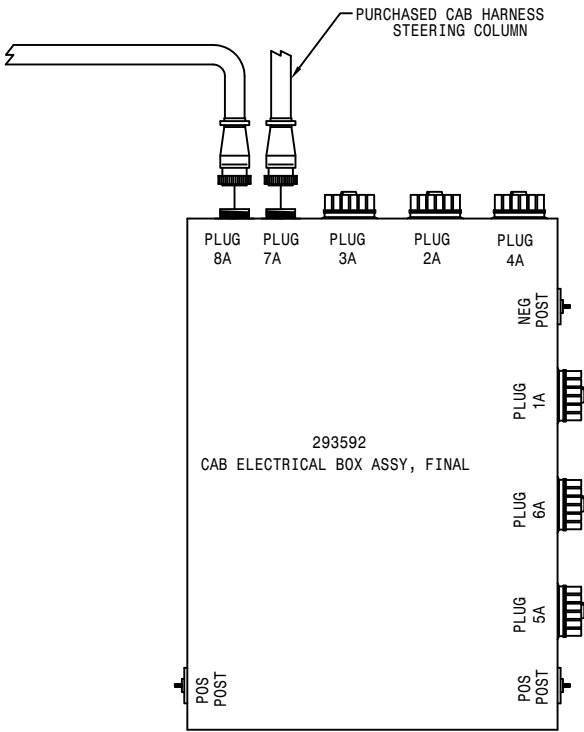
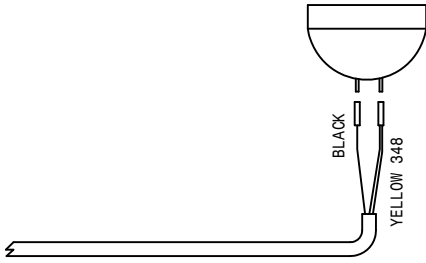

01-16-02 TLM
 STS 10 WIRING DIAGRAM 02
 COMBO
 SHEET 6 OF 7
 REVISION DATE: 03-04-02
 498638

293670 - POWER HARNESS
 MAIN STS COMBO (SHEET 4 OF 7)
 293642 - JUMPER HARNESS
 CAB TO RECEPTICAL (SHEET 4 OF 7)

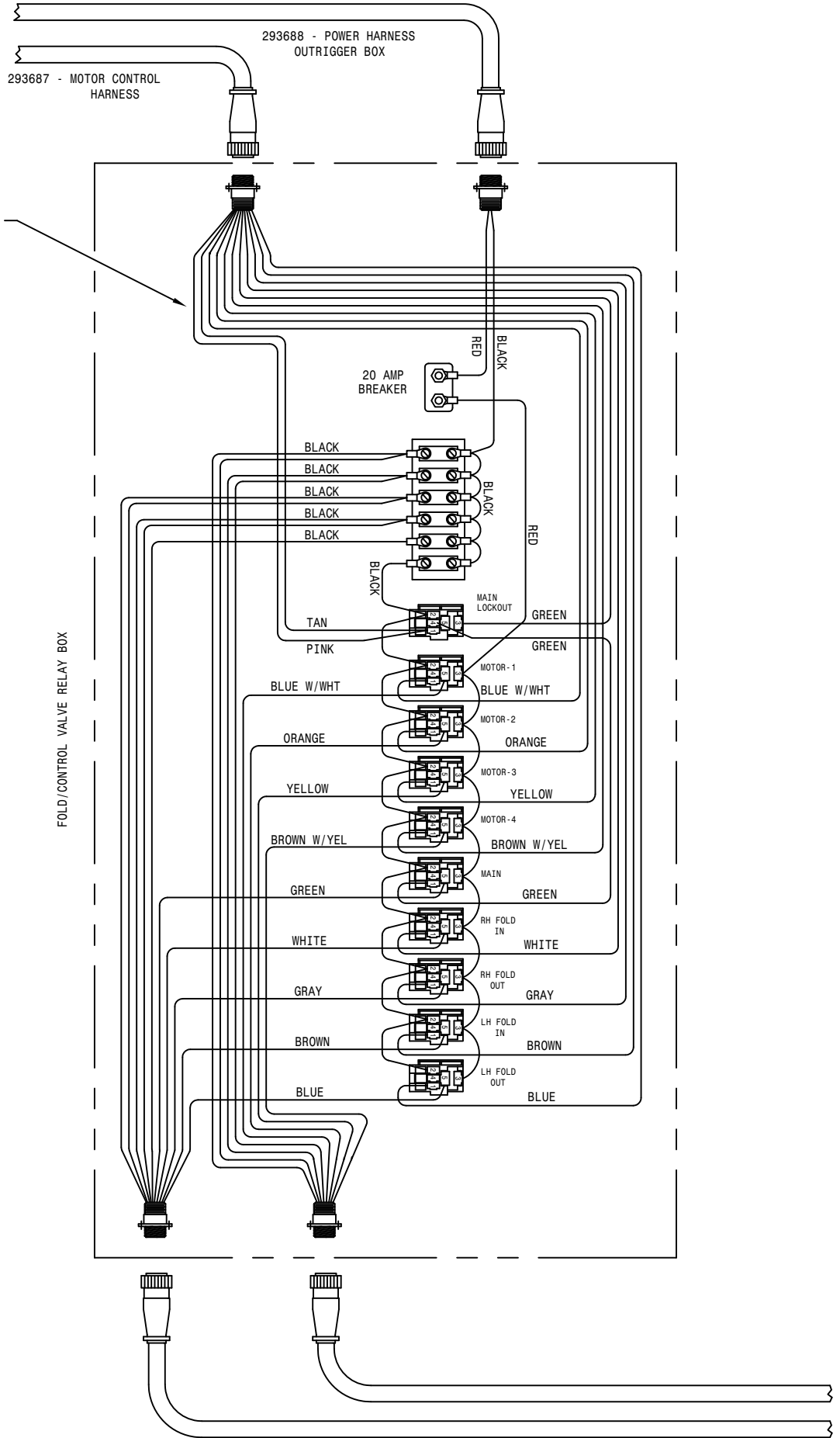

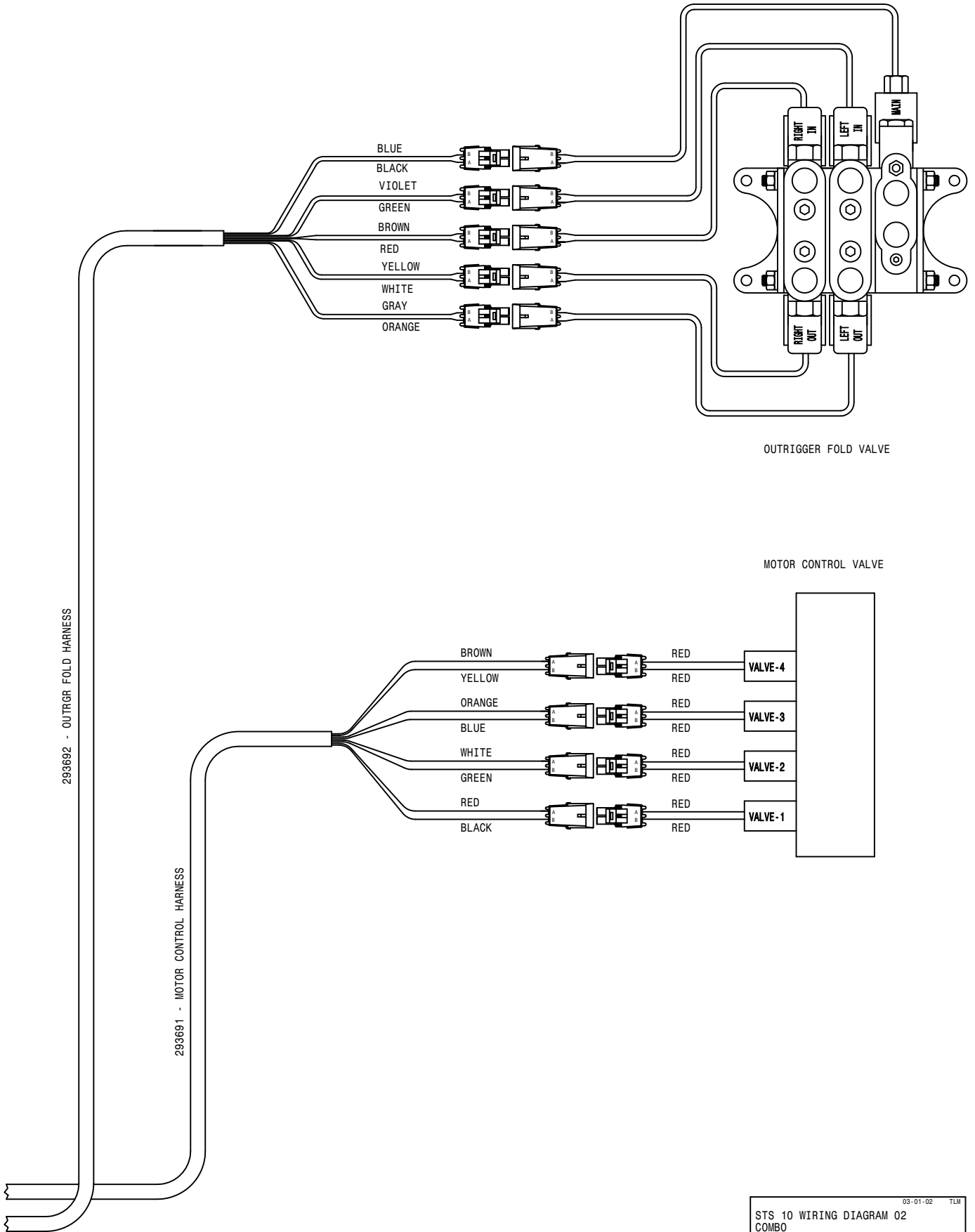

03-01-02 TLM
 STS 10 WIRING DIAGRAM 02
 COMBO
 SHEET 7 OF 7
 REVISION DATE: 498638

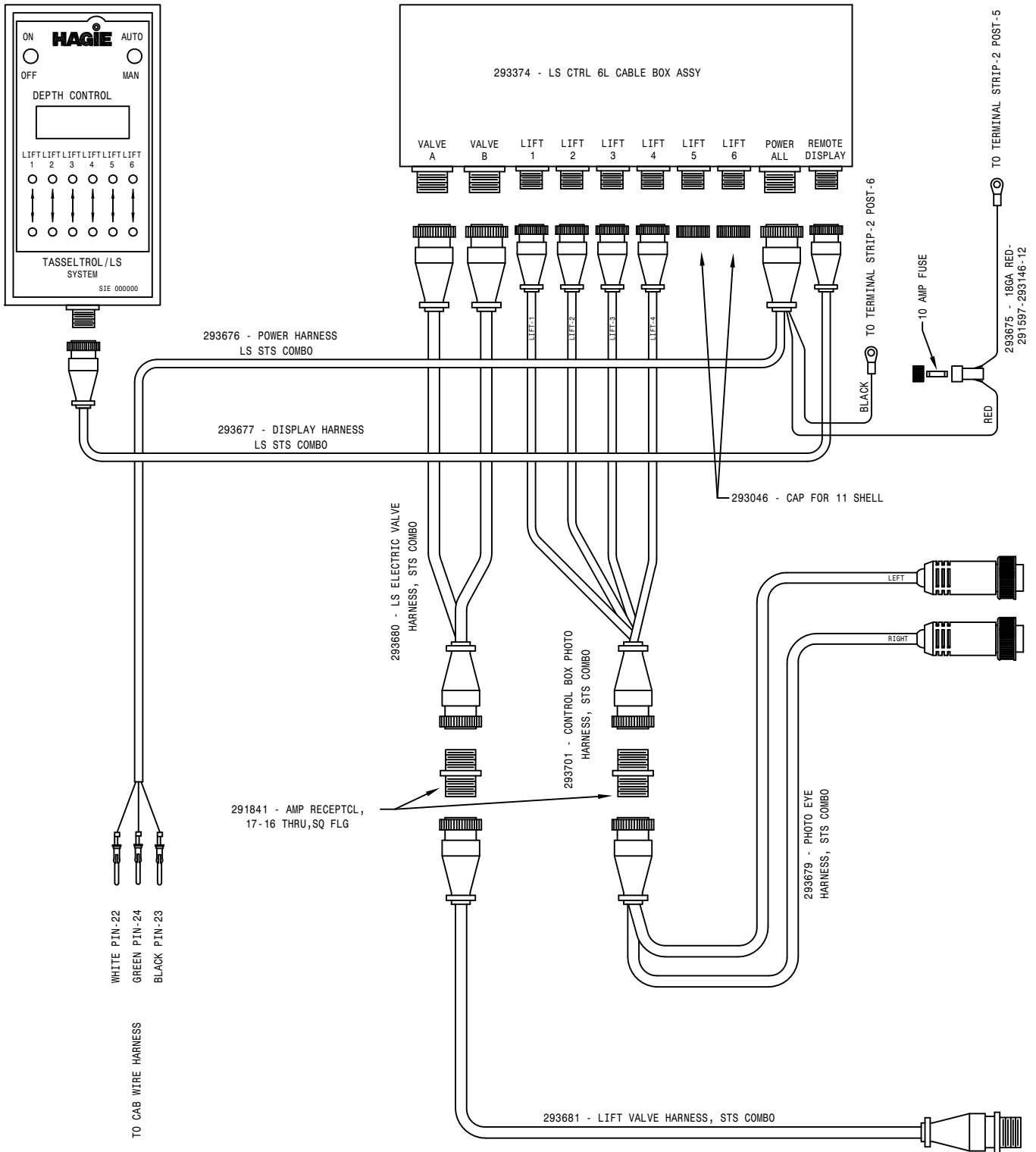

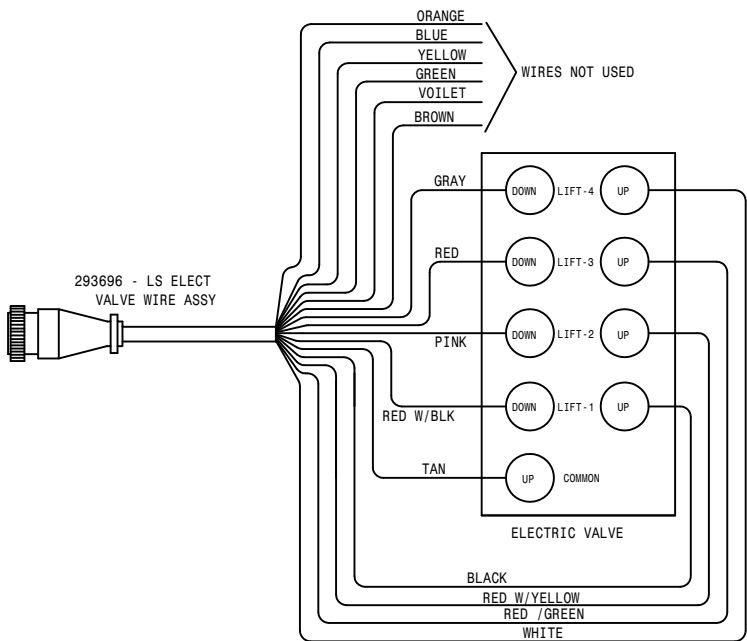
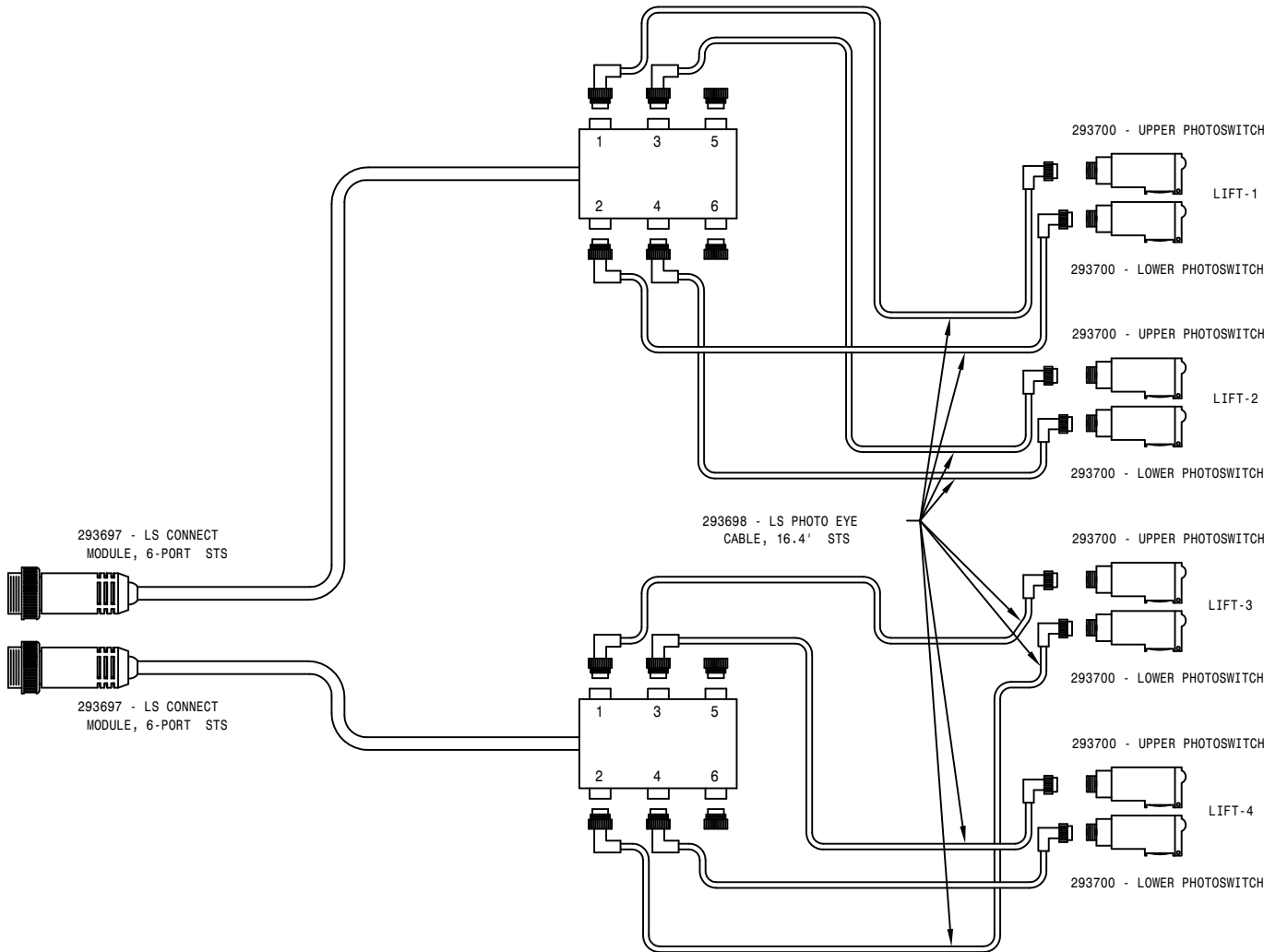

DET	REQ	DESCRIPTION
HAGIE		
HAGIE MANUFACTURING COMPANY		
CLARION, IOWA 50525		
REMOVE ALL SHARP CORNERS & BURRS		
TOLERANCE UNLESS OTHERWISE SPECIFIED		
FRACTION	+ 1/32	DECIMALS X.XX 1/32 X.XXX 1/64
DESCRIPTION LS SYS 4L WIRE DIAG, STSC 02		
DRAWN BY T. MARKER	SCALE FULL	
CHECKED BY	APPROVED BY	
DATE 01-17-02	DRAWING NUMBER 498705	
SHEET	OF	

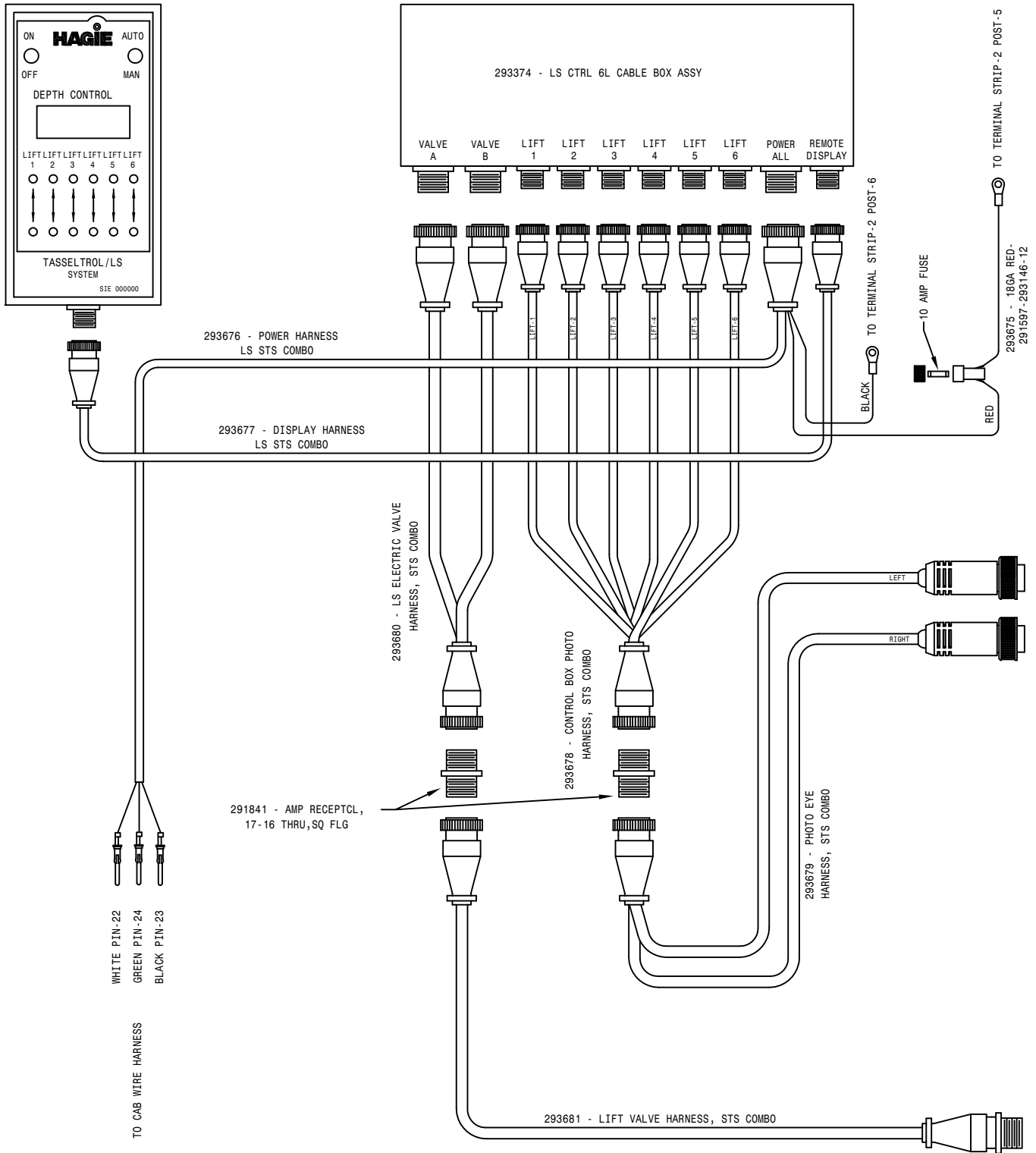

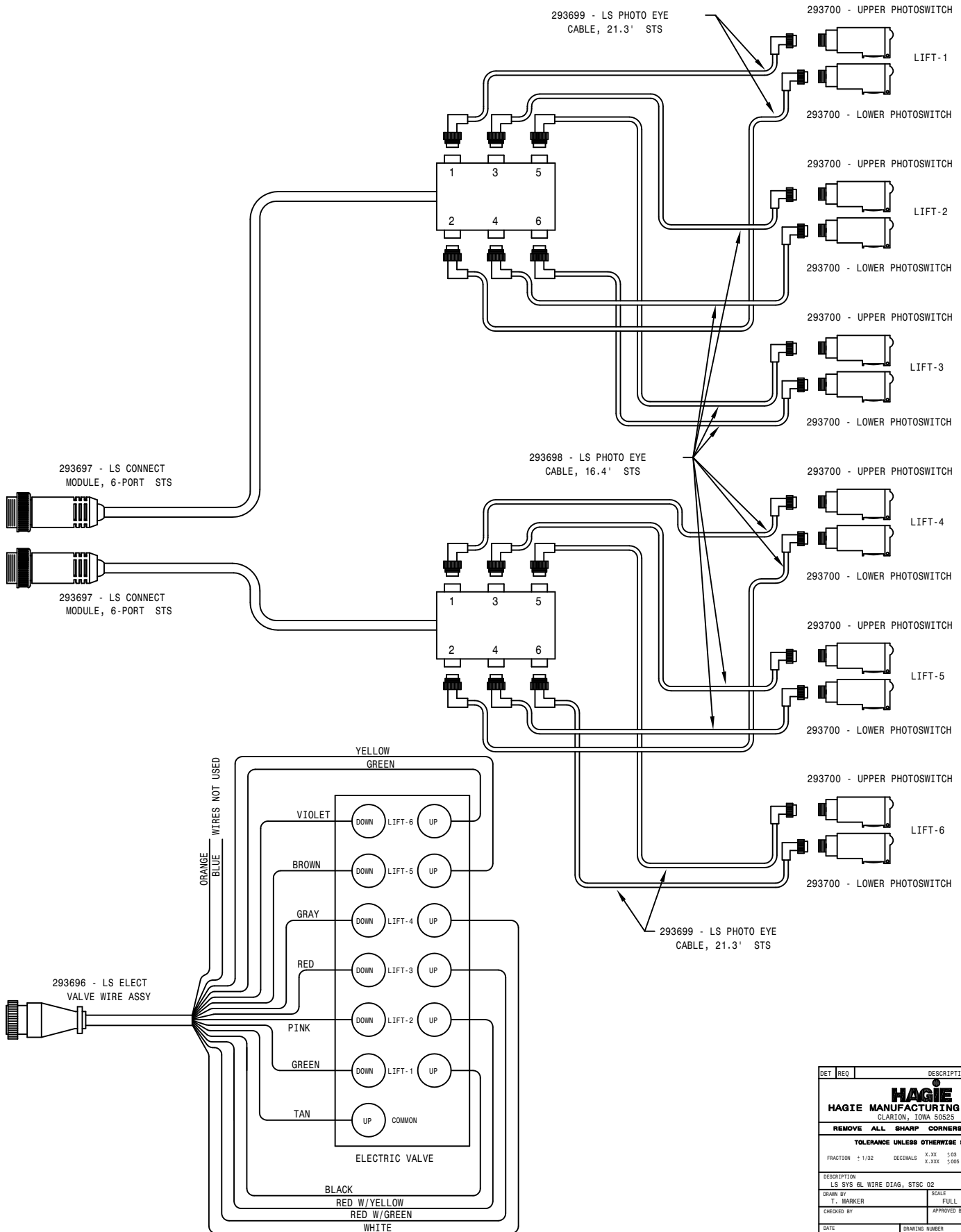

DET REQ		DESCRIPTION	
HAGIE MANUFACTURING COMPANY CLARION, IOWA 50525			
REMOVE ALL SHARP CORNERS & BURRS			
TOLERANCE UNLESS OTHERWISE SPECIFIED			
FRACTION	± 1/32	DECIMALS	X.XX ±.03 X.XXX ±.005
DESCRIPTION		SCALE	
LS SYS RL WIRE DIAG, STSC 02		FULL	
DRAWN BY T. MARKER		APPROVED BY	
DATE 01-17-02	DRAWING NUMBER 498706		
SHEET	OF		

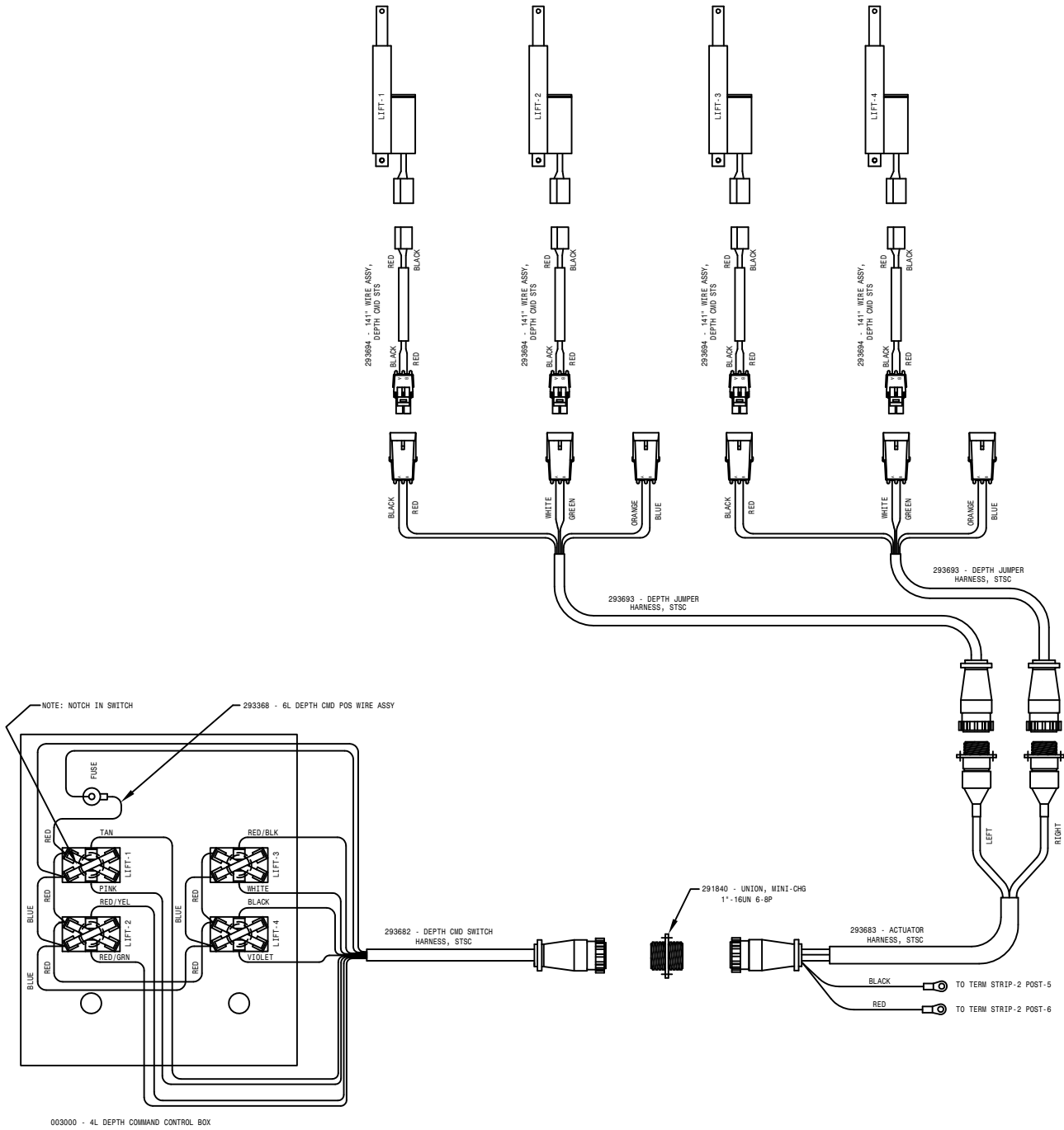

DET	REQ	DESCRIPTION
HAGIE HAGIE MANUFACTURING COMPANY CLARION, IOWA 50525		
REMOVE ALL SHARP CORNERS & BURRS		
TOLERANCE UNLESS OTHERWISE SPECIFIED		
FRACTION	+ 1/32	DECIMALS X.XX 5.03 X.XXX 5.005
ANGLES		+ °
DESCRIPTION DEPTH CMD 4L WIRE DIAG, STSC 02		
DRAWN BY T. MARKER	SCALE NONE (1)	
CHECKED BY	APPROVED BY	
DATE 01-18-02	DRAWING NUMBER 498707	
SHEET	OF	

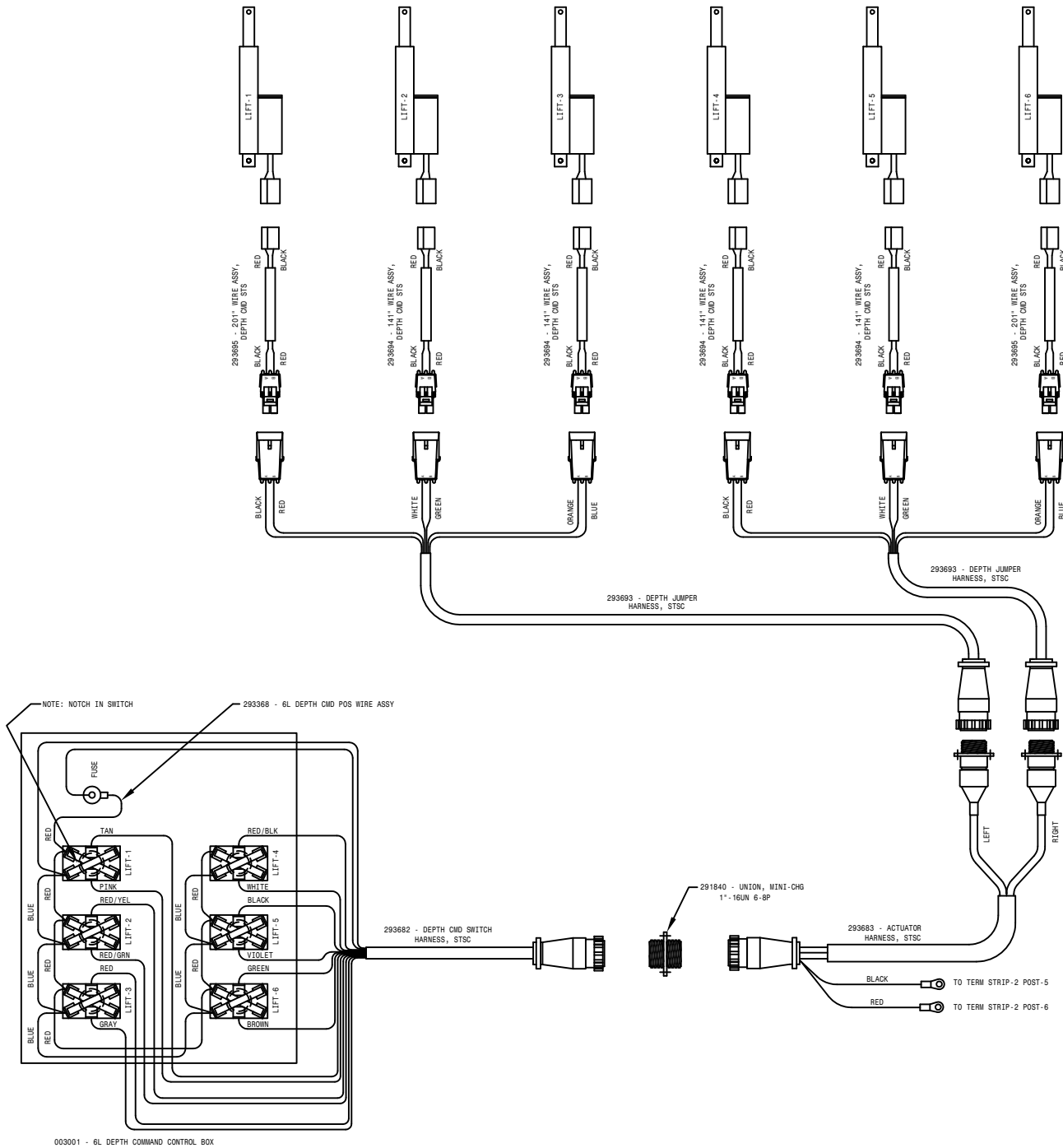

003001 - 6L DEPTH COMMAND CONTROL BOX

DET	REV	DESCRIPTION
HAGIE HAGIE MANUFACTURING COMPANY CLARION, IOWA 50525		
REMOVE ALL SHARP CORNERS & BURRS TOLERANCE UNLESS OTHERWISE SPECIFIED		
FRACTION	† 1/32	DECIMALS .X.XX .5/32 X.XXX 5/64
ANGLES	°	
DESCRIPTION		
DEPTH CMD 6L WIRE DIAG, STSC 02		
DRAWN BY	T. MARKER	SCALE NONE (1)
CHECKED BY		APPROVED BY
DATE	01-18-02	DRAWING NUMBER
		498708
SHEET	OF	

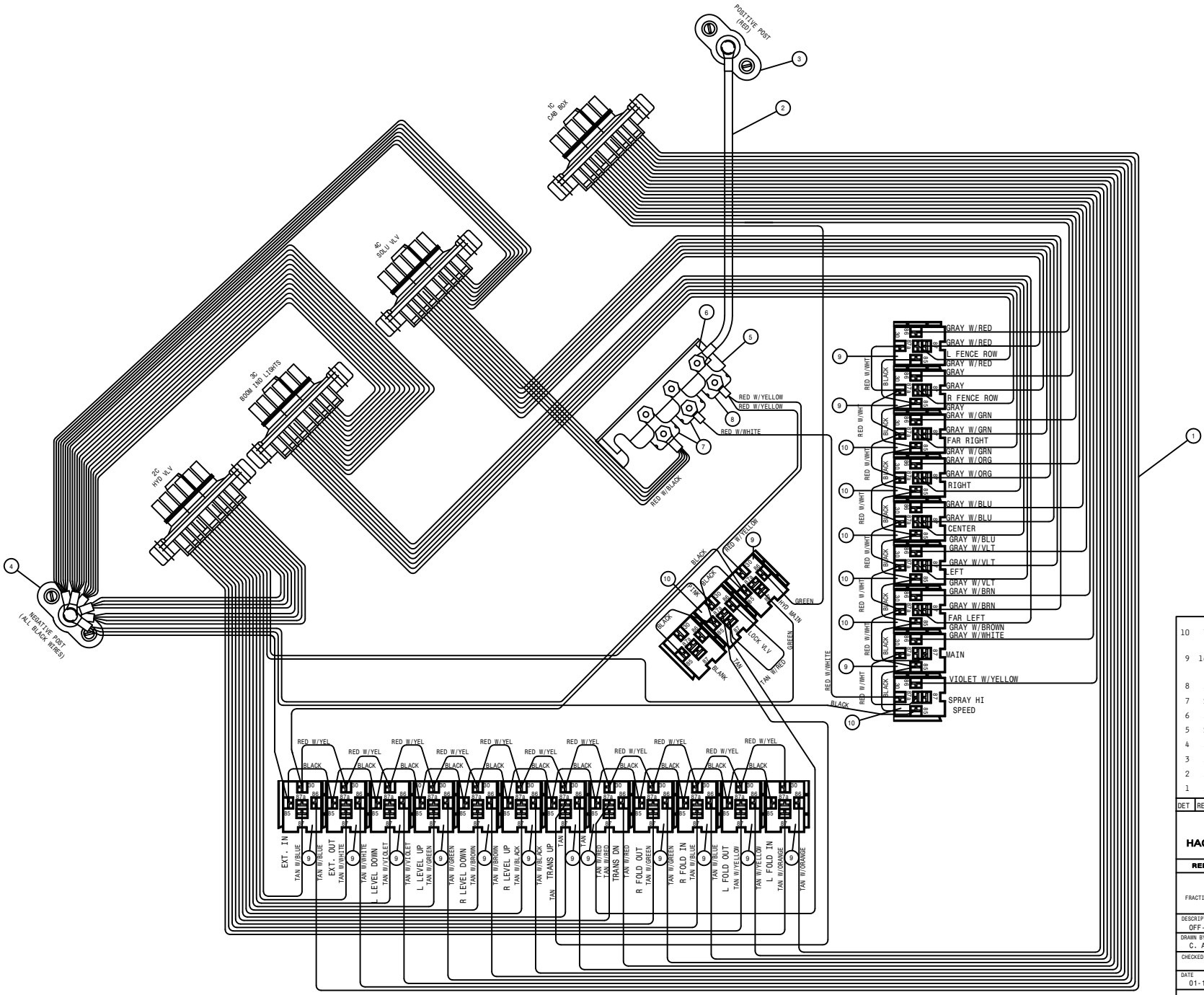

10	7	291752	RELAY, SPDT 12V 50A-NO 5-TERM BOSH 0332 209 137
9	16	291751	RELAY, SPST 12V 40A-NO, DIODE BOSH 0332 019 155
8	1	291573	CIRCUIT BREAKER, 20AMP W/O MT
7	2	291574	CIRCUIT BREAKER, 30AMP W/O MT
6	1	291756	BUS BAR, 4-GANG FOR 291755
5	2	291755	BREAKER MTG BRKT, 4-GANG NYLON
4	1	291749	TERM BLOCK, BLACK, 3/8-16 THRU
3	1	291750	TERM BLOCK, RED, 3/8-16 THRU
2	1	291803	BATT CABLE, RED 9"6GA.218-.250
1	1	293600	BOOM CTRL BOX HARNESS (342829)

DET	REQ	DESCRIPTION
HAGIE HAGIE MANUFACTURING COMPANY CLARION, IOWA 50525		
REMOVE ALL SHARP CORNERS & BURRS		
TOLERANCE UNLESS OTHERWISE SPECIFIED		
FRACTION	± 1/32	DECIMALS X.XX 1/32 X.XXX 1/600
ANGLES 1°		
DESCRIPTION OFF-SITE PARTS/ASSY FOR 293590		
DRAWN BY C. ADAMS	SCALE NONE (1)	
CHECKED BY	APPROVED BY	
DATE 01-18-00	DRAWING NUMBER 293591	
SHEET	OF	

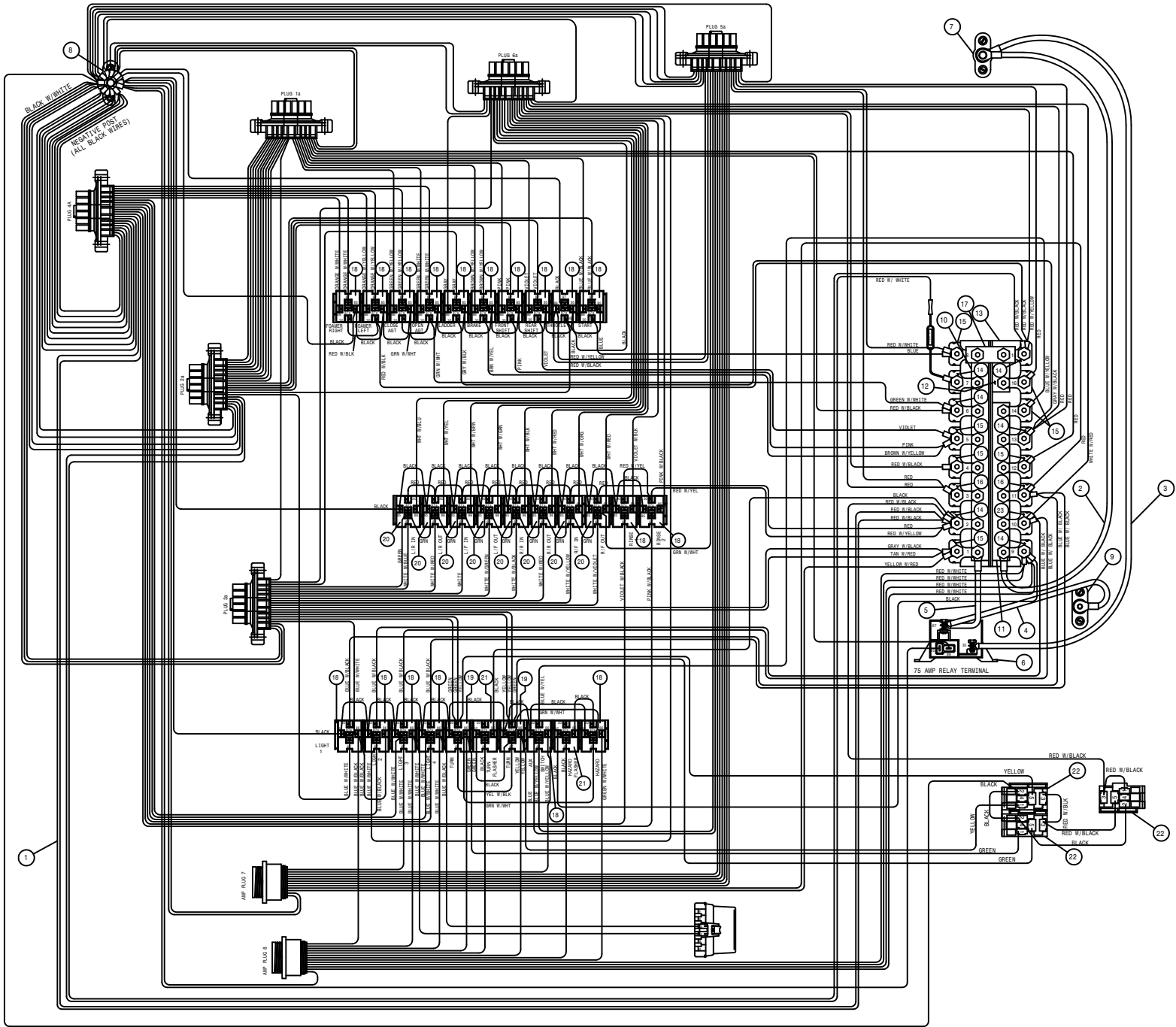

- 23 1 291584 CIRCUIT BREAKER, 40AMP W/O MT
- 22 3 291781 MICRO RELAY, BOSCH 12V SPDT
- 21 2 291564 FLASHER, 12V 3-PIN ELECTRONIC
- 20 8 291698 RELAY, TYPE 4V 12V DC 30A
- 19 2 291752 RELAY, SPDT 12V 50A-ND 5-TERM
- 18 18 291751 RELAY, SPST 12V 40A-ND 5-TERM
- 17 1 291683 BUSS BAR, 2-GANG CIRCUIT BREAKER
- 16 2 291574 CIRCUIT BREAKER, 30AMP W/O MT
- 15 7 291573 CIRCUIT BREAKER, 20AMP W/O MT
- 14 6 291575 CIRCUIT BREAKER, 10AMP W/O MT
- 13 2 291757 BREAKER MTG BRKT, 8-GANG NYLON
- 12 1 291796 BUSS BAR, 2-GANG FOR 291757
- 11 1 291797 BUSS BAR, 6-GANG FOR 291757
- 10 1 291758 BUSS BAR, 8-GANG FOR 291757
- 9 1 291748 TERM BLOCK, BLACK, 1/4-20 THRU
- 8 1 291749 TERM BLOCK, BLACK, 3/8-16 THRU
- 7 1 291750 TERM BLOCK, RED, 3/8-16 THRU
- 6 1 657371 RELAY, 12 VOLT 75 AMP
- 5 1 291801 BATT CABLE, RED 7*6GA, 218-.218
- 4 1 291803 BATT CABLE, RED 9*6GA, 218-.250
- 3 1 291809 BATT CABLE, RED 20*6GA, 218-.375
- 2 1 291808 BATT CABLE, RED 18*6GA, 218-.375
- 1 1 293605 MAIN CAB BOX HARNESS (342840)

DET	REQ	DESCRIPTION
HAGIE		
HAGIE MANUFACTURING COMPANY		
CLARION, IOWA 50525		
REMOVE ALL SHARP CORNERS & BURRS		
TOLERANCE UNLESS OTHERWISE SPECIFIED		
FRACTION	+1/32	DECIMALS X.XX .03 X.XXX .005
ANGLES	°	
DESCRIPTION OFF-SITE PARTS/ASSY FOR 293592		
DRAWN BY C. ADAMS	SCALE NONE (1)	
CHECKED BY	APPROVED BY	
DATE 01-10-00	DRAWING NUMBER 293593	
SHEET	OF	

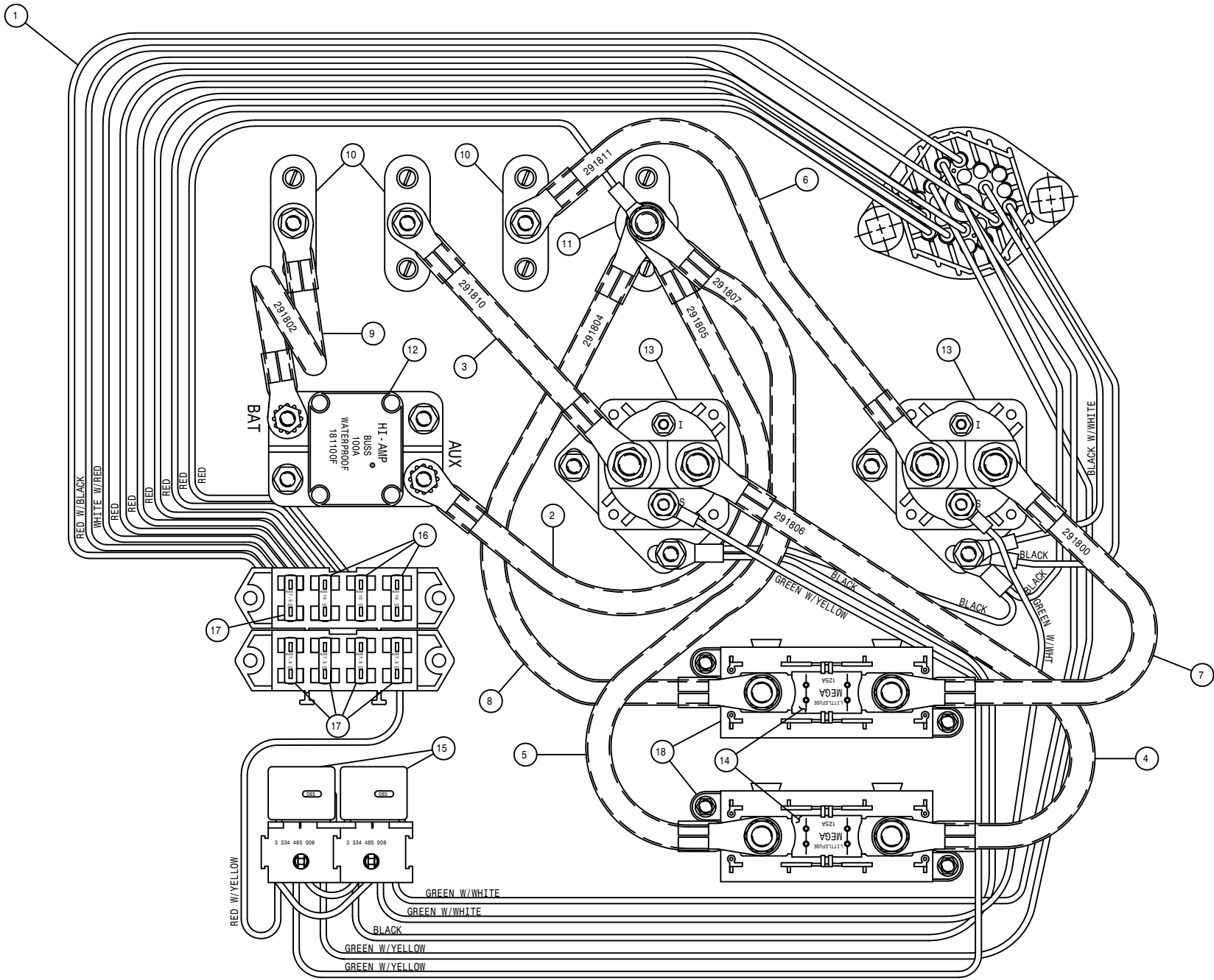

18	2	291814	FUSE HOLDER, HIGH AMP
17	5	291027	7.5 AMP FUSE, 1/4"BLADE ATD/ATC
16	3	291545	10 AMP FUSE, 1/4"BLADE ATD/ATC
15	2	291751	RELAY, SPST 12V 40A-NO 5-TERM
14	2	291813	125 AMP FUSE
13	2	291816	SOLENOID
12	1	291815	CIRCUIT BREAKER, 100 AMP BUSS
11	1	291750	TERM BLOCK, RED, 3/8-16 THRU
10	3	291748	TERM BLOCK, BLACK, 1/4-20 THRU
9	1	291802	BATT CABLE, RED 8*6GA. 281-.281
8	1	291804	BATT CABLE, RED 9*6GA. 343-.406
7	1	291800	BATT CABLE, RED 6*6GA. 343-.343
6	1	291811	BATT CABLE, BLK 8*6GA. 281-.343
5	1	291807	BATT CABLE, RED 12*6GA. 343-.406
4	1	291806	BATT CABLE, RED 11*6GA. 343-.343
3	1	291810	BATT CABLE, BLK 5*6GA. 281-.343
2	1	291805	BATT CABLE, RED 11*6GA. 281-.406
1	1	293626	ENGINE BOX HARNESS (342850)

DET	REQ	DESCRIPTION
HAGIE HAGIE MANUFACTURING COMPANY CLARION, IOWA 50525		
REMOVE ALL SHARP CORNERS & BURRS		
TOLERANCE UNLESS OTHERWISE SPECIFIED		
FRACTION	1/32	DECIMALS
ANGLES	1/2	1/16
DESCRIPTION		
OFF-SITE PARTS/ASSY FOR 293594		
SCALE	NONE (1)	
DRAWN BY	C. ADAMS	
CREATED BY	APPROVED BY	
DATE	01-20-00	SHIPPING NUMBER
SHEET	OF	293595

ABBREVIATIONS

A/C - AIR CONDITIONER	MT - MOUNT
ADPTR - ADAPTER	MTR - MOTOR
AGI - AGITATOR	P/N - PART NUMBER
ALT - ALTERNATOR	PLT - PLATE
ASSY - ASSEMBLY	QTY - QUANTITY
BRKT - BRACKET	RED - REDUCER
DET - DETAIL	REF - REFERENCE
DISPL - DISPLACEMENT	REST - RESTRICTOR
EL - ELBOW	REQ - REQUIRED
EXT - EXTENSION	SHFT - SHAFT
FLO - FLOW	SOL - SOLUTION
FNPT - FEMALE NATIONAL PIPE THREAD	STRG - STEERING
FOR - FEMALE O-RING	ST - STREET
FRT - FRONT	SWIV - SWIVEL
HYD - HYDRAULIC	UNC - UNIFIED NATIONAL COURSE
HYDRO - HYDROSTATIC	UNF - UNIFIED NATIONAL FINE
LG - LONG	V - VOLT
LWR - LOWER	W/ - WITH
MJIC - MALE J.I.C.	WHL - WHEEL
MOR - MALE O-RING	WLD - WELDMENT

INDEX

-A-

ABBREVIATIONS.....185
ACCUMULATOR.....93
AIR DRYER.....13
AIR CLEANER.....10
 FILTER.....10
AIR COMPRESSOR GOVERNOR.....10
AIR CONDITIONER
 BINARY SWITCH.....9
 COMPRESSOR.....7
 CONDENSOR COIL.....12
 HOSE.....9,12
 RECEIVER/DRYER.....9
 TUBE.....31
AIR COOLER, CHARGE.....12
AIR PRESSURE GAUGE.....40,84
AIR REGULATOR, FOAMER.....84
AIRRIDE SPRING.....20,22,24,26
AIR VALVE.....20,22,24,26
ALTERNATOR.....5
ARM, STEERING.....20,22,24,26
ATI CONTROLER.....44

-B-

BACK-UP BEEPER.....12
BALL VALVE.....52,63
 ELECTRIC..53,56,57,58,59,60,65
BATTERY.....16
 CABLE.....4,5,10,16
 BOX PANEL.....12
BEARING,
 BRONZE LEG.....20,22,24,26,32
 ORKOT.....20,22,24,26
BELT,
 AIR CONDITIONER.....7
 DRIVE.....5
BLOCK, TERMINAL.....40
BOOM.....94,95,96,97
 CRADLE.....98,99,100
 INDICATOR LIGHT.....89
 PIN.....96,97,98
 VALVE.....90,91
BOX,
 ELECTRICAL.....36,37,38
 PRESSURE WASHER.....106
 FOLD/CONTROL VALVE BOX.....125
 SIDE FILL.....112
BRACE, RADIATOR.....9
BREAKAWAY CYLINDER.....97,105
BUMPER, REAR.....49

-C-

CAB.....39
 FILTER.....39
 STABILIZER.....39
CABLE BATTERY.....4,5,10,16
CAP,
 FUEL.....14
 RADIATOR.....12
CHARGE AIR COOLER.....12
CHEMICAL INDUCTOR.....113
COMPRESSOR, A/C.....7
CONDENSOR COIL, A/C.....12
CONTROLER, ATI.....44
COOLER, OIL.....12
CRADLE, BOOM.....98,99,100
CUTTER HEAD.....137
 RETURN MANIFOLD.....139
CYLINDER,
 BREAKAWAY.....97,105
 FOLD.....93,96,102,104,131,135
 GAS.....48
 LEVEL.....93,103
 LIFT.....92,101,134
 SIDE FILL.....113,116
 STEERING.....20,22,28
 TREAD ADJUST.....32,33

-D-

DECALS.....140,141
DIAGRAMS, WIRING.....162
DIPSTICK, HYDRAULIC.....15
DOOR LATCH.....48
DRAIN COCK, AIR.....13
DRIVE
 BELT.....5
 DISK.....4

-E-

ELECTRIC BALL VALVE...56,57,58,59
ELECTRICAL BOX,
 BOOM.....36
 CAB.....38
 ENGINE.....37
ENGINE.....4,5
 SKID.....9

-F-

FAN.....5
 SPACER.....5

FEEDER TEE.....61,62,67,68
 FENCE ROW NOZZLE.....72,73
 FENDER.....119,120
 FILTER,
 AIR CLEANER.....10
 CAB.....39
 FUEL.....4
 HYDRAULIC....17,34,122,127,128
 MINDER.....10
 OIL.....5,15
 FLASHER.....30,49
 FLOW DIVIDER.....122
 FLOW METER.....59,65,121
 FOAMER
 AIR REGULATOR.....84
 DROP HOSE.....88
 HOSING.....76
 TANK.....83
 THREE-WAY VALVE.....83
 VALVE.....83
 FOLD CYLINDER...93,96,103,131,135
 FRAME, SHEETMETAL.....49
 FRESH WATER.....85
 FRONT FILL.....117
 FUEL,
 CAP.....14
 SENDER.....14
 TANK.....14

-G-

GAS CYLINDER.....48
 GAUGE,
 AIR PRESSURE.....40,84
 SOLUTION.....59,65

-H-

HANDRAIL.....50
 HEAD,
 CUTTER.....137
 PULLER.....136
 HEATER TUBE.....31
 HOSE, A/C.....9
 HOSING,
 FOAMER.....82
 SOLUTION.....74,76,78,80
 HUB, TORQUE.....21,23,25,27
 HYDRAULIC,
 FILTER.....17,122
 LEVER.....42
 SCHEMATIC.....142
 TANK.....15
 TUBE.....30,31,92,95
 VALVE.....18,19,126,127,128
 HYDROSTATIC PUMP.....8

-I-

IGNITION SWITCH.....43
 INDICATOR LIGHT, BOOM.....89
 INLINE, HYDRAULIC FILTER.....34

-L-

LADDER.....51
 LEG.....20,22,24,26
 LEVEL CYLINDER.....93,103
 LEVER, HYDROSTATIC.....42
 LIFT CYLINDER.....92,101,134
 LIFTARM.....92
 LIGHT.....30,100
 LINE STRAINER.....53,58
 LIQUID LEVEL SWITCH.....15
 LS CONTROL BOX.....45

-M-

MIRROR.....46,47
 MONITOR,
 SPRAYER.....44
 FLOWMAX 110.....121
 MOTOR,
 CONTROL VALVE.....130
 STEERING.....39
 WHEEL.....21,23,25,27
 MOUNT, RUBBER.....9,12
 MUFFLER.....11

-N-

NOZZLE,
 BODY.....71
 FENCE ROW.....72,73
 MOUNT TUBE.....95,96,97
 REAR WHEEL.....64,70

-O-

OIL COOLER.....12
 OIL FILTER.....5,15

-P-

PANEL,
 BATTERY BOX.....12
 SWITCH.....43
 PLATFORM, SERVICE.....50
 PRESSURE GAUGE.....59,65
 PRESSURE WASHER.....107
 BOX.....106
 VALVE.....109,110
 PULLER, QUAD.....136

PUMP,
 HYDRAULIC.....6
 HYDROSTATIC.....8
 SIDE FILL.....113,114
 SOLUTION.....56

-Q-

QUAD PULLER.....136

-R-

RACHET JACK.....131,132
 RADIATOR.....12
 BRACE.....9
 CAP.....12
 HOSE.....5
 RADIO.....41
 REAR WHEEL NOZZLE.....64,70
 RECEPICLE PANEL.....124
 RECOVERY TANK.....48
 RETURN MANIFOLD.....134
 RINSE TANK.....53
 RUBBER
 MOUNT.....9,12
 SPRING.....20,22,24,26

-S-

SCHEMATIC, HYDRAULIC.....142
 SENDER, FUEL.....14
 SENDER, WATER LEVEL.....12
 SEVICE PLATFORM.....50
 SHEET METAL.....48,49
 SHIELD, WHEEL MOTOR...21,23,25,27
 SIDFILL.....113,114
 BOX.....112
 CYLINDER.....113,114
 SIGHT GAUGE,
 OIL.....15
 SOLUTION.....55
 SKID, ENGINE.....9
 SMV SIGN.....49
 SOLUTION
 HOSING.....74,76,78,80
 PUMP.....56
 SIGHT GAUGE.....55
 TANK.....52,54
 VALVE.....59,60,65
 SPACER, FAN.....5
 SPEAKER.....41
 SPRAY MONITOR.....44
 SPRING,
 AIRRIDE.....20,22,39
 SOLUTION TANK.....52
 STABILIZER, CAB.....42
 STARTER.....5

STEERING,
 ARM.....20,22,24,26
 CYLINDER.....20,22,28
 MOTOR.....39
 STRAINER, LINE.....53,58
 SWITCH,
 A/C BINARY.....9
 IGNITION.....43
 LIQUID LEVEL.....15
 PANEL.....43

-T-

TAILLIGHT.....49
 TANK
 AIR.....13
 FOAMER.....83
 FRESHWATER.....85
 FUEL.....14
 HYDRAULIC.....15
 RECOVERY.....48
 RINSE.....53
 SOLUTION.....52,54
 TERMINAL BLOCK.....40
 TIRE.....29
 TOOLBAR.....131,132
 TORQUE HUB.....21,23,25,27
 TRANSOM.....93
 TREAD ADJUST
 CYLINDER.....32,33
 VALVE.....34,35
 TUBE,
 A/C.....31
 HEATER.....31
 HYDRAULIC.....30,31,92,95

-V-

VALVE,
 AIR.....20,22,24,26,39
 BALL.....52,63
 BOOM.....90,91
 ELECTRIC BALL...53,56,57,58,65
 FOAMER.....83,86,87
 HYDRAULIC....9,18,126,127,128
 PRESSURE WASHER.....109,110
 SIDE FILL.....111,115
 SOLUTION.....59,60,63
 TREAD ADJUST.....34,35

-W-

WASHER, PRESSURE.....107
 WATER LEVEL SENSOR.....12
 WHEELMOTOR.....21,23,25,27
 SHIELD.....21,23,25,27
 WIRING DIAGRAM.....162



PARTS ORDER FAX

Fax
24 hours
a day
7 days
a week*

Ph. 1 (800) 247-4885

Fx. 1 (515) 532-3553

Photocopy and fax to Hagie Customer Support Department

ORDERED BY/BILL TO:

Name _____
 Co. Name _____
 Street _____
 City, St, Zip _____
 Ph. _____ Fx. _____

SHIP TO:

Name _____
 Co. Name _____
 Street _____
 City, St, Zip _____
 Ph. _____ Fx. _____

HOW SHIP: UPS Ground Next Day 2 Day 3 Day Other _____

If "HOW SHIP" is left blank, parts will be sent UPS ground service. If part is over 150 pounds, an independent motor freight company will be used.

PAYMENT: Hagie Account #** _____
 C.O.D

American Express Discover Visa Master Card

Signature: _____
 name as appears on card: _____
 card no. _____ exp. date _____

Year and Model No. _____

Serial No. _____

Item Serial No. (if necessary):

Engine (include type) _____

Hydrostatic Pump (s) _____

Torque Hub _____ LF RF LR RR

Wheel Motor _____ LF RF LR RR

HAGIE Part No.	Qty.	Description

Check here if you want phone confirmation of parts order.

* Orders received before 3:00 p.m., CST will be processed the same business day.
 Regular business hours are Monday through Friday, 7:00 a.m. through 5:00 p.m..

** If you do not have a Hagie account number, contact the Hagie Customer Support Department and you will be issued one.



PARTS ORDER FAX

Fax
24 hours
a day
7 days
a week*

Ph. 1 (800) 247-4885

Fx. 1 (515) 532-3553

Photocopy and fax to Hagie Customer Support Department

ORDERED BY/BILL TO:

Name _____
 Co. Name _____
 Street _____
 City, St, Zip _____
 Ph. _____ Fx. _____

SHIP TO:

Name _____
 Co. Name _____
 Street _____
 City, St, Zip _____
 Ph. _____ Fx. _____

HOW SHIP: UPS Ground Next Day 2 Day 3 Day Other _____

If "HOW SHIP" is left blank, parts will be sent UPS ground service. If part is over 150 pounds, an independent motor freight company will be used.

PAYMENT: Hagie Account #** _____
 C.O.D

American Express Discover Visa Master Card

Signature: _____
 name as appears on card: _____
 card no. _____ exp. date _____

Year and Model No. _____

Serial No. _____

Item Serial No. (if necessary):

Engine (include type) _____

Hydrostatic Pump (s) _____

Torque Hub _____ LF RF LR RR

Wheel Motor _____ LF RF LR RR

HAGIE Part No.	Qty.	Description

Check here if you want phone confirmation of parts order.

* Orders received before 3:00 p.m., CST will be processed the same business day.
 Regular business hours are Monday through Friday, 7:00 a.m. through 5:00 p.m..

** If you do not have a Hagie account number, contact the Hagie Customer Support Department and you will be issued one.