



TABLE OF CONTENTS

1 – INTRODUCTION

A Word From Hagie Manufacturing Company	1-1
About This Manual	1-1
Safety Messages Used In This Manual	1-2
Service and Assistance	1-3
Reporting Accidents, Injuries, or Safety Concerns	1-3
Specifications	1-4
2015 Product Warranty	1-10

2 – SAFETY AND PRECAUTIONS

Intended Use	2-1
Safety Precautions	2-1
Safety Decals	2-3

3 – OPERATING YOUR NTB

Fold Procedure	3-1
Float Operation	3-6
Application	3-9

4 – MAINTENANCE AND STORAGE

Service - Lubrication	4-1
Service - Mounting Bolt Torque (60' HsTB)	4-5
Storage	4-5

5 – MISCELLANEOUS

Transporting	5-1
Gauge Wheel Adjustment	5-3
Coulter Adjustment	5-4
Quick-Tach System	5-5



SECTION 1 – INTRODUCTION

The following patent decal is located on the front of the attachment and provides current patents issued on your Nitrogen Tool Bar.

NOTE: Hagie Manufacturing Company reserves the right to make changes to any current patents or patents pending at any time, without notice.



Hagie Manufacturing Patent Decal
(Located on the front of attachment)

A WORD FROM HAGIE MANUFACTURING COMPANY

Congratulations on the purchase of your Nitrogen Toolbar (NTB)! We recommend that you review this operator's manual and become familiar with operating procedures and safety precautions before attempting to operate your NTB.

As with any piece of equipment, certain operating procedures, service, and maintenance are required to keep your NTB in top running condition. We have attempted herein to cover all of the adjustments required to fit varying conditions. However, there may be times when special care must be considered.

NOTE: The user is responsible for inspecting the NTB and having parts repaired or replaced when continued use of the product causes damage or excessive wear to other parts.

Hagie Manufacturing Company reserves the right to make changes in the design and material of any subsequent NTB without obligation to existing units.

Thank you for choosing a Hagie NTB and we ensure you of our continued interest and support in its optimal performance for you. We are proud to have you as a customer!

ABOUT THIS MANUAL

NOTICE

The purpose of this manual is to guide you in operating the NTB. Read this manual in addition to the sprayer operator's manual, and all other literature that is included with the machine. This manual is only intended to cover the NTB attachment and any differences in the operation of the sprayer controls. Refer to your sprayer operator's manual for complete instructions on machine operation.

NOTICE

Any pictures contained within this operator's manual that depict situations with shields, guards, rails, or lids removed are for demonstration only. Hagie Manufacturing Company strongly urges the operator to keep all shields and safety devices in place at all times.

NOTICE

Reference to right and left-hand used throughout this manual refers to the position when seated in the operator's seat facing forward.

This manual will aid you in the proper operation and service of your Nitrogen Toolbar (NTB). It is the responsibility of the user to read the operator's manual and comply with the correct and safe operating procedures, as well as maintain the product according to the service information provided in the *Maintenance and Storage Section* elsewhere in this manual.

Photographs and illustrations used in this manual are of general nature only. Some of the equipment described and/or shown may or may not be available on your NTB.

Information described in this manual was correct at the time of printing. Because of Hagie Manufacturing Company's continuous product improvement, certain information may not be included in this manual. To obtain the most current operator's manual for your attachment, please visit www.hagiehelp.com.

Keep this manual in a convenient place for easy reference. This manual is considered a permanent fixture of the product. In the event of resale, this manual should accompany the NTB.

If you do not understand any part of this manual or require additional information or service, contact Hagie Customer Support for assistance.

SAFETY MESSAGES USED IN THIS MANUAL

The following safety messages found throughout this manual alert you of situations that could become potentially dangerous to the operator, service personnel, or equipment.

DANGER

This symbol indicates a hazardous situation which, if not avoided, will result in serious injury or death.

WARNING

This symbol indicates a potentially hazardous situation which, if not avoided, could result in moderate/serious injury or death.

CAUTION

This symbol indicates a potentially hazardous situation which, if not avoided, may result in minor or moderate injury. It may also be used to alert against unsafe practices.

NOTICE

This symbol indicates operator awareness which, if not avoided, may result in personal or property damage.

NOTE: A "Note" is intended to make special mention of, or remark on.

SERVICE AND ASSISTANCE

For service and assistance, please contact:

Hagie Manufacturing Company
721 Central Avenue West
P.O. Box 273
Clarion, IA 50525-0273
(515) 532-2861 OR (800) 247-4885
www.hagiehelp.com

REPORTING ACCIDENTS, INJURIES, OR SAFETY CONCERNS

Should an accident or injury occur involving the use of a Hagie product, or if you have a product safety concern, report such information directly to Hagie Customer Support at (800) 247-4885.

SPECIFICATIONS

Hagie Manufacturing Company offers its Nitrogen Toolbar (NTB) in 12-row, 16-row, 18-skip row, and 24-skip row configurations, depending on model. The 6-ft. (182 cm) clearance (30/40' NTB) allows growers to side-dress nitrogen later in the growing season, in some situations, after tassels have topped.

NTB units are set for 30" (76 cm) rows, but some can accommodate 20, 22, or 36-inch (50, 55, or 91 cm) rows. They are capable of applying 80 to 100 lbs. (36 to 45 kg) of nitrogen at 14 to 16 mph (22 to 25 km/h), which is approximately twice the speed of tractor-pulled units.

Description	12-Row NTB	16-Row NTB	18-Row NTB	24-Row NTB	24-Row 60' HsTB
Skip Row	N/A	N/A	X	X	N/A
Standard Coulter Row Units	11	15	9	12	23
Electro-Hydraulic Fold/Lift/Level	X	X	X	X	X
100 PSI (6.9 bar) Glycerin-Filled Pressure Gauge	X	X	X	X	X
Solution Control Valves	3	3	3	3 (40'NTB)	3

Fold Points (30' NTB)

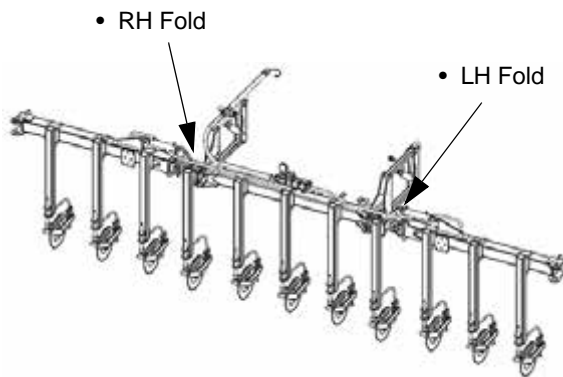

30' NTB Fold Points
(Unfolded position shown)
-Typical View



30' NTB Fold Points
(Folded position shown)
-Typical View

Fold Points (40' NTB)

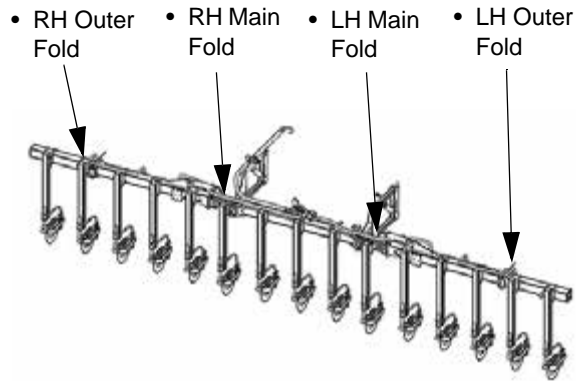

40' NTB Fold Points
(Unfolded position shown)
-Typical View



40' NTB Fold Points
(Folded position shown)
-Typical View

Fold Points (60' HsTB)

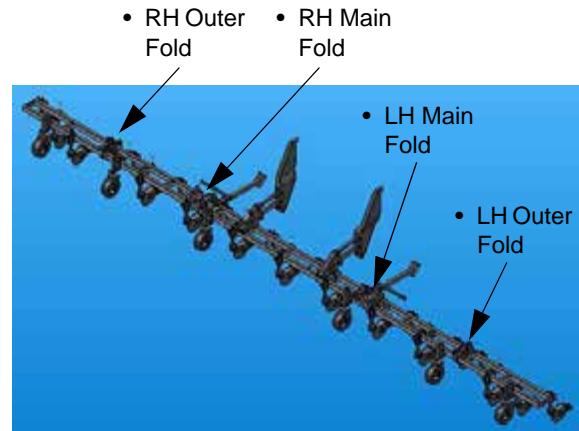

60' HsTB Fold Points
(Unfolded position shown)
-Typical View

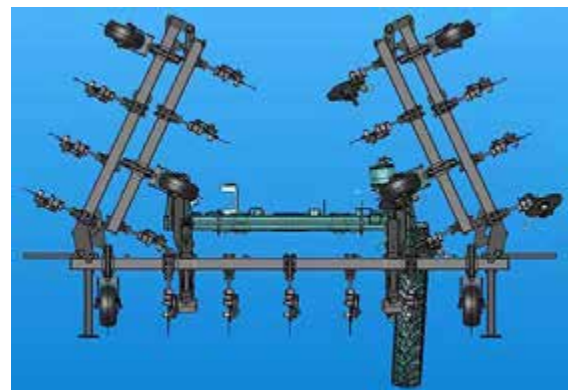

60' HsTB Fold Points
(Folded position shown)
-Typical View

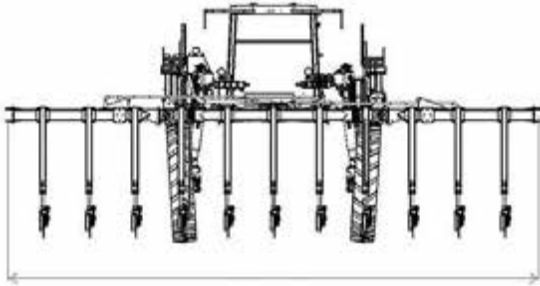
NTB Transport Dimensions**30' NTB Dimensions****30' NTB**

- Overall Unfolded Width = 350"/29'-2" (889 cm)

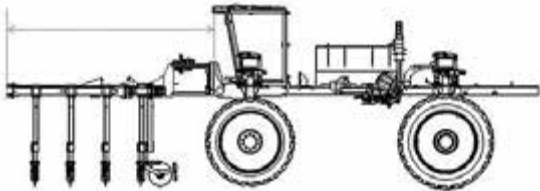
**30'NTB**

- Length (from front of machine to front of folded NTB) = 175"/14'-7" (444.5 cm)

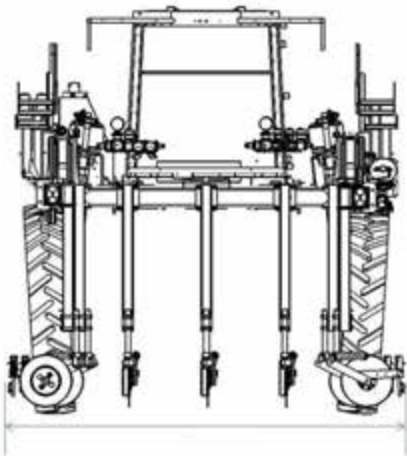
**30' NTB**

- Overall Folded Width = 146"/12'-2" (370.8 cm)

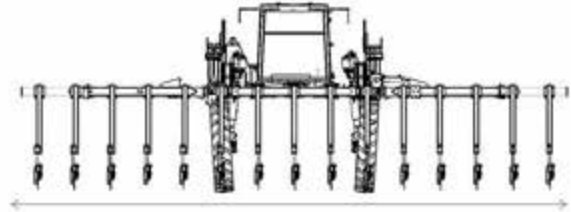
40' NTB Dimensions**40' NTB**

- Overall Unfolded Width = 449.5"/37'-5" (11.4 m)

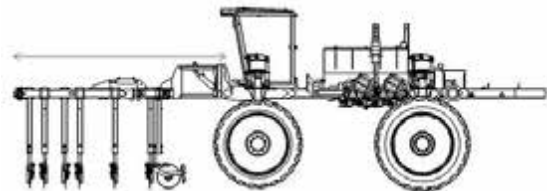
**40'NTB**

- Length (from front of machine to front of folded NTB) = 180"/15' (457.2 cm)

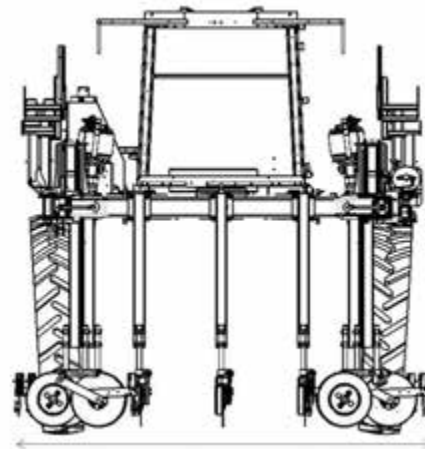
**40' NTB**

- Overall Folded Width = 150"/12'-6" (381 cm)

60-ft. HsTB Dimensions

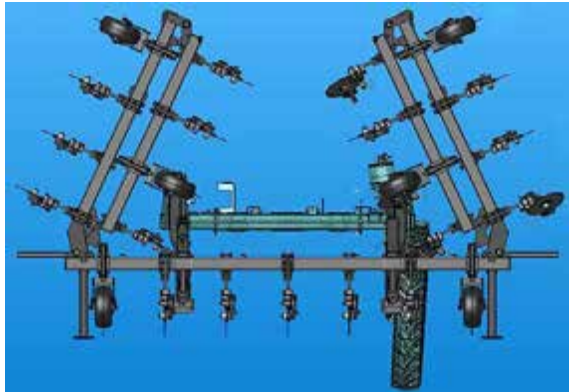

60' HsTB

- Overall Width (when folded for transport) = 272"/22'-8" (690.9 cm)
- Overall Height (when folded and raised for transport) = 178"/14'-10" (452.1 cm)

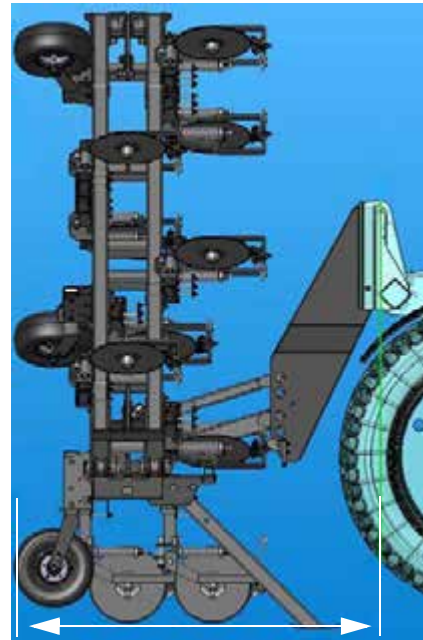

60' HsTB

- Width (from front of gauge wheel to rear of quick-tach) = 96"/8'-0" (243.8 cm)

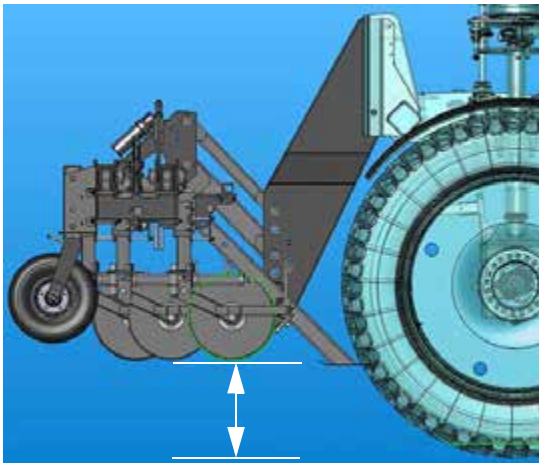

60' HsTB

- Height (from bottom of coulters to ground) = 19" (48.3 cm)

NTB Layout

The following illustrations define the NTB design and will aid in identifying the various toolbar configurations.

30' NTB**12-Row/30" (76.2 cm) Spacing**

30' NTB
12-Row/30" (76.2 cm) Spacing

18-Skip Row/20" (50.8 cm) Spacing

30' NTB
18-Skip Row/20" (50.8 cm) Spacing

40' NTB**16-Row/30" (76.2 cm) Spacing**

40' NTB
16-Row/30" (76.2 cm) Spacing

24-Skip Row/20" (50.8 cm) Spacing

40' NTB
24-Skip Row/20" (50.8 cm) Spacing

60' HsTB

24-Row/30" (76.2 cm) Spacing



60' HsTB
24-Row/30" (76.2 cm) Spacing

NTB Weight

(Approximate)

30' NTB

- 4,776 lbs./2,166 kg

40' NTB

- 5,996 lbs./2,719 kg

60' HsTB

- 8,020 lbs./3,637 kg

2015 PRODUCT WARRANTY

Hagie Manufacturing Company Product Warranty

Hagie Manufacturing Company warrants each new Hagie product to be free under normal use and service from defects in workmanship and materials for a period of lesser of: two (2) years or 1,000 hours from the date of delivery on all Agricultural Products. Hagie Manufacturing Company makes this warranty from the original delivery date and is transferable to a purchaser from the original purchaser of this equipment, given there is remaining time left under the year and hour warranty standard stated above. This warranty shall be fulfilled by repairing or replacing free of charge any part that shows evidence of defect or improper workmanship, provided the part is returned to Hagie Manufacturing Company within thirty (30) days of the date that such defect or improper workmanship is discovered, or should have been discovered. Labor to repair said items will be covered by standard labor time rates. Freight charges of defective parts are not covered by this warranty and are the responsibility of the purchaser. No other express warranty is given and no affirmation of Hagie Manufacturing Company, by words or action, shall constitute a warranty.

Hagie Manufacturing Company limits its warranty to only those products manufactured by Hagie Manufacturing Company and does not warrant any part or component not manufactured by Hagie Manufacturing Company, such as parts or components being subject to their manufacturer's warranties, if any. Excluded from this warranty are parts subjected to accident, alteration, or negligent use or repair. This warranty does not cover normal maintenance such as engine tune ups, adjustments, inspections, nor any consumables such as tires, rubber products, solution system valves, wear parts, wiper blades, etc.

Hagie Manufacturing Company shall not be responsible for repairs or replacements which are necessitated, in whole or in part; by the use of parts not manufactured by or obtainable from Hagie Manufacturing Company nor for service performed by someone other than Hagie authorized personnel, unless authorized by Hagie Manufacturing Company. Customer acknowledges that it is not relying on Hagie Manufacturing Company's skill or judgment to select finish goods for any purpose and that there are no warranties which are not contained in this agreement.

In no event shall Hagie Manufacturing Company's tort, contract, or warranty liability exceed the purchase price of the product. The foregoing limitation will not apply to claims for personal injury caused solely by Hagie Manufacturing Company's negligence.

Hagie Manufacturing Company shall not be liable for damages, including special, incidental or consequential damages or injuries (damage and repairs of equipment itself, loss of profits, rental or substitute equipment, loss of good will, etc.) arising out of or in connection with performance of the equipment or its use by customer, and Hagie Manufacturing Company shall not be liable for any special, incidental or consequential damages arising out of or in connection with Hagie Manufacturing Company's failure to perform its obligation hereunder. HAGIE MANUFACTURING COMPANY'S ENTIRE LIABILITY AND THE CUSTOMER'S EXCLUSIVE REMEDY SHALL BE REPAIR OR REPLACEMENT OF PARTS COVERED UNDER THIS WARRANTY. THIS WARRANTY IN LIEU OF ALL OTHER WARRANTIES, EXPRESSED OR IMPLIED, INCLUDING, BUT NOT LIMITED TO THE IMPLIED WARRANTY OF MERCHANTABILITY OR FITNESS FOR A PARTICULAR PURPOSE.



SECTION 2 – SAFETY AND PRECAUTIONS

INTENDED USE

NOTICE

This attachment is designed for and intended to be used for the application of nitrogen to field crops. Use in any other way or for any other purpose is considered misuse of this attachment.

Most accidents occur as the result of failure to follow basic and fundamental safety rules and precautions. Recognizing potential safety hazards, following correct and safe operating procedures described in this manual, and complying with safety warnings located throughout the machine and attachment may reduce the risk of accidents.

There is no way to completely eliminate the potential for danger when operating agricultural equipment. Therefore, you must study this operator's manual and understand how to operate the attachment controls for safe operation before using the attachment. Likewise, never let anyone operate the attachment without proper instruction.

Do not operate the attachment for anything other than its intended use. Hagie Manufacturing Company shall not be liable for any damage, injury, or death associated with improper use of the attachment.

Do not make any modifications such as, but not limited to, weldments, add-ons, adaptations, or changes from the original design of the attachment. Such modifications may become safety hazards to you and others and **will void all warranties.**

Replace missing, faded, or damaged safety signs. Refer to "Safety Decals" elsewhere in this section for correct sign and placement.

SAFETY PRECAUTIONS

General Safety

- The hydraulic and electrical control systems are optimized for use with this attachment. Any modification to these systems may lead to unintended or uncontrolled motion. Do NOT install add-on control systems that are not approved by Hagie Manufacturing Company.
- Some conditions cannot be completely safeguarded against without interfering with efficient operation of the machine and/or reasonable accessibility. In these cases, decals have been installed to provide the operator with hazard information. Do NOT remove decals for any reason. If a decal is damaged or missing, contact the Hagie Customer Support Department for replacement.



Wear Protective Clothing

- Do not wear loose fitting clothing that could get caught in moving parts. Wear safety equipment that is appropriate for the job.



- Do not store chemical-soaked clothing in the cab. Clean off as much mud and dirt from your shoes as you can before entering the cab.

Be Prepared

- Be prepared for an emergency. Keep a fire extinguisher handy. Keep a first aid kit and clean water in the cab.
- Make sure to service the fire extinguisher regularly. Keep an accurate inventory of supplies in the first aid kit and dispose of anything that has expired.



General Maintenance Safety

- Turn off sprayer engine before checking, adjusting, repairing, lubricating, or cleaning any part of the attachment.
- Remove all chemical residue from the work area before performing service/maintenance.
- Disconnect the battery ground cable and turn the Battery Disconnect Switch OFF before servicing the electrical system or welding on an attachment.



Safe Hydraulic Maintenance

- Always practice personal safety when performing service or maintenance on the hydraulic system.



- Use caution when working around hydraulic fluid under pressure. Escaping

fluid can have sufficient force to penetrate your skin, causing serious injury. This fluid may also be hot enough to burn.

- Always lower the load or relieve pressure before repairing a hydraulic leak.
- Avoid torching, welding, and soldering near pressurized hydraulic lines. Pressurized lines may accidentally burst when heat goes beyond the immediate flame area.



Oil-Over-Air Scenarios

- Upon initial startup of the NTB, be ready for possible rapid movement, should some air become trapped in the cylinders.

DO NOT ALLOW PEOPLE TO STAND IN LOCATIONS WHERE THE NTB COULD STRIKE THEM!



- Clear area of personnel, then operate all attachment functions (i.e. main lift, main fold, up/down movement of outer sections, outer folds, and left and right-hand wings) two (2) times simultaneously to force out any air in the system.

Handle Agricultural Chemicals Safely

Agricultural chemicals used in applications can be harmful to your health and the environment if not used properly.

- Always follow the manufacturer’s label for directions of use.
- Never allow chemicals to come in contact with your skin or eyes. Always use the proper Personal Protective Equipment (PPE).
- Never pour chemicals into an empty tank. Always fill tank half full of water first.
- Dispose of empty chemical containers properly.



- Wash spilled chemicals or residue away to prevent corrosion and deterioration.
- Select safe areas to fill, flush, calibrate, and clean sprayer where chemicals will not run off to contaminate people, animals, vegetation, or water supply.
- Never place a spray nozzle to your mouth in an attempt to unplug it.
- Do not spray when wind is in excess of chemical manufacturer’s recommendation.
- Store chemicals in their original containers with the label intact.
- Store chemicals in a separate, locked building.
- Wear protective equipment as recommended by the chemical manufacturer.

SAFETY DECALS

Decals warning you of avoidable danger are located on various parts of the attachment. They are there for your personal safety and protection. **DO NOT** remove them. They will fracture upon attempted removal and therefore, must be replaced.

Following are locations of important safety decals. Replace them if they are damaged or missing. All safety decals,

instructional decals, or machine striping may be purchased through the Hagie Customer Support Department.

To replace safety decals, ensure the installation area is clean and dry and decide on exact position before you remove the backing paper.

Safety Decal Locations

30’ NTB

650137

(Located near electrical box cover)



650178

(2) - Quick-Tach



650204
(6) - Located near each fold point



650219
(2) - Located on each lift arm weldment



650339
(Located on front cross-member)



40' NTB
650137
(Located near electrical box cover)



650178
(2) - Quick-Tach



650204
(8) - Located near each fold point



SECTION 2 –
SAFETY AND PRECAUTIONS



650219
(2) - Located on each lift arm weldment



650204
(10) - Located near each fold point



650339
(Located on front cross-member)



650208
(2) - Located on each outer fold extension



650339
(Located on front cross-member)



60' HsTB

650178
(2) - Quick-Tach



650447**(2) - Located near center section weldment
on each parking stand**



SECTION 3 – OPERATING YOUR NTB

FOLD PROCEDURE

WARNING

Before proceeding, check area around the machine for bystanders, overhead objects, and power lines. Failure to comply may result in serious injury or death.

NOTE: 30/40' NTBs fold horizontally and the 60' HsTB folds vertically.

Unfold Nitrogen Toolbar (from storage position)

NOTE: If you are unfolding a 30/40' NTB, proceed to Step 2.

1. Ensure the main fold sections are in the UNLOCKED position (60' HsTB only). Refer to “Transporting” provided in *Section 5 - Miscellaneous* elsewhere in this manual for further information.
2. Ensure the Hydrostatic Drive Control Handle is in the NEUTRAL position.

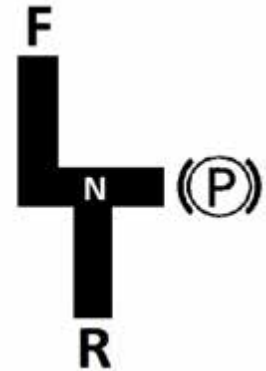

Hydrostatic Drive Control Handle
(Version 1)
-Typical View

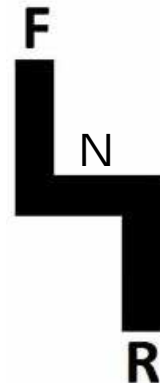

Hydrostatic Drive Control Handle
(Version 2)
-Typical View

3. Press the Field/Road Button (located on the Machine Display Home Page) and change the machine's drive state to FIELD mode.

NOTE: The selected drive state will illuminate.



Field/Road Button
(Located on the Machine Display
Home Page)

NOTE: The machine's drive state cannot be changed unless the Hydrostatic Drive Control Handle is in the NEUTRAL position.

4. Press and hold the Transom Switch (located on the Hydrostatic Drive Control Handle) in the UP position to raise the NTB up off ground.



Transom Switch - UP
(Located on the Hydrostatic
Drive Control Handle - Version 1)
-Typical View



Transom Switch - UP
(Located on the Hydrostatic Drive
Control Handle - Version 2)
-Typical View

NOTE: Ensure coulters clear the ground.

5. Unfold each main fold section by pressing and holding the corresponding Left and Right Boom/NTB Switches (located on the Hydrostatic Drive Control Handle) in the OUT position.

NOTE: 60' HsTB - Unfold main fold sections by pressing and holding the Left and Right Boom/NTB Switches in the DOWN position.



Left and Right Boom/NTB Switches
(Located on the Hydrostatic Drive
Control Handle - Version 1)
-Typical View

NOTE: Both left and right outer fold extensions will unfold simultaneously when this switch is pressed.



Boom/NTB Extension Switch
(Located on the side console)
-Typical View



Left and Right Boom/NTB Switches
(Located on the Hydrostatic Drive
Control Handle - Version 2)
-Typical View

7. If necessary, retract (raise) the parking stands (60' HsTB only). Refer to “Transporting” provided in *Section 5 - Miscellaneous* elsewhere in this manual for further information.

Fold Nitrogen Toolbar (to storage position)

1. Ensure the Hydrostatic Drive Control Handle is in the NEUTRAL position.
2. Ensure the machine’s drive state is in FIELD mode.
3. Press the Float Button (located on the Machine Display Auxiliary Controls Page) and turn Float operation OFF.

Outer Fold Extensions (40' NTB/60' HsTB only)

6. Unfold each outer fold extension by pressing and holding the Boom/NTB Extension Switch (located on the side console) in the UP (Out) position.

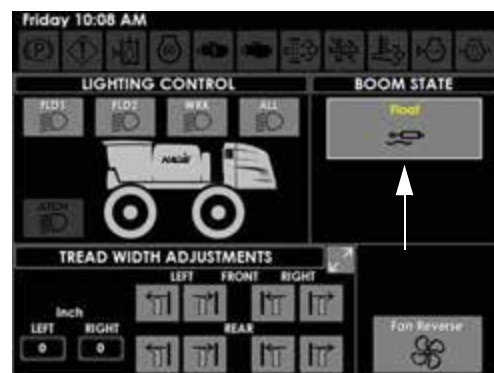

Float Button
(Located on the Machine Display
Auxiliary Controls Page)

4. Press and hold the Transom Switch (located on the Hydrostatic Drive Control Handle) in the UP position to raise the NTB up off ground.



Transom Switch - UP
(Located on the Hydrostatic Drive Control Handle - Version 1)
-Typical View



Transom Switch - UP
(Located on the Hydrostatic Drive Control Handle - Version 2)
-Typical View

NOTE: Ensure coulters clear the ground.

Outer Fold Extensions (40' NTB/60' HsTB only)

NOTICE

Fold each outer fold extension IN before folding in the main fold sections. Failure to comply will result in property damage.

5. Fold in each outer fold extension by pressing and holding the Boom/NTB Extension Switch (located on the side console) in the DOWN (In) position.

NOTE: Both left and right outer fold extensions will fold simultaneously when this switch is pressed.



Boom/NTB Extension Switch
(Located on the side console)
-Typical View

6. Fold in each main fold section by pressing and holding the corresponding Left and Right Boom/NTB Switches (located on the Hydrostatic Drive Control Handle) in the IN position.

NOTE: 60' HsTB - Fold main fold sections in by pressing and holding the Left and Right Boom/NTB Switches in the UP position.



Left and Right Boom/NTB Switches
(Located on the Hydrostatic Drive
Control Handle - Version 1)
-Typical View



Left and Right Boom/NTB Switches
(Located on the Hydrostatic Drive
Control Handle - Version 2)
-Typical View

Outer Fold Extension Transport Latches (60' HsTB only)

Your 60' HsTB is equipped with two (2) Outer Fold Extension Transport Latches (located near each left and right-hand main fold point) that automatically lock the outer fold extensions into position when folded via

gravity. These latches engage and disengage automatically when the outer fold extensions are extended and retracted.

If the outer fold extension(s) do not extend and retract when depressing the Boom/NTB Extension Switch (located on the side console), the Outer Fold Extension Transport Latch may be manually disengaged by lifting up on the latch.

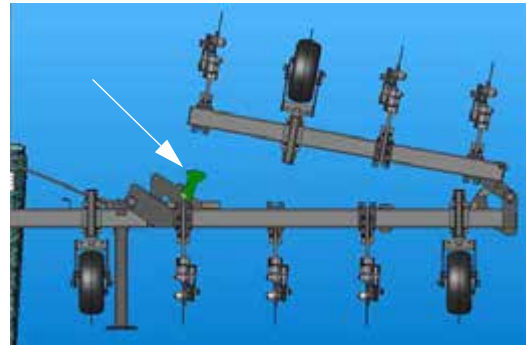

Outer Fold Extension Transport Latch
(Located near each left and
right-hand main fold point)
-Typical View
* 60' HsTB only

Adjusting the Main Fold Sections

The main fold sections of the attachment (where the left and right-hand main fold section connects to the main lift) may be adjusted to desired height.

- Press the corresponding Left and Right Boom/NTB Switches (located on the Hydrostatic Drive Control Handle) UP or DOWN to desired position.

NOTE: 60' HsTB - The up/down functions on the Hydrostatic Drive Control Handle also fold/unfold the 60' HsTB. Press the Left and Right Boom/NTB Switches in the UP or DOWN position to level the toolbar. Continue pressing and holding these switches in the DOWN position to unfold the main fold sections, or the UP position to fold the main fold sections in.

FLOAT OPERATION

NOTICE

Ensure Float operation is enabled when operating the NTB. Failure to comply may result in property damage.

Float operation allows the NTB to raise up and down while riding through the field to avoid machine damage due to uneven ground.

Float operation may be activated using various methods. In all options, Float must be enabled through the Machine Display and the machine must be in Field Mode.

Master Spray Switch

(Default Setting)

The Master Spray Switch (located on the Hydrostatic Drive Control Handle) controls both the solution valves and the Float “Down” functions when Float is enabled.

1. Press the Field/Road Button (located on the Machine Display Home Page) and change the machine’s drive state to FIELD mode.

NOTE: The selected drive state will illuminate.



Field/Road Button
(Located on the Machine Display Home Page)

NOTE: The machine’s drive state cannot be changed unless the Hydrostatic Drive Control Handle is in the NEUTRAL position.

2. Press the Float Button (located on the Machine Display Auxiliary Controls Page) to enable Float operation.

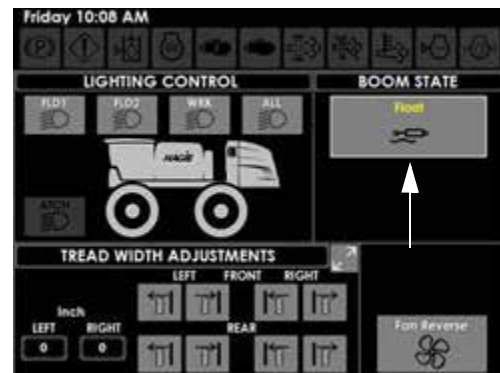

Float Button
(Located on the Machine Display Auxiliary Controls Page)

3. Float will now be activated when the Master Spray Switch is pressed.



Master Spray Switch
(Located on the back side of the Hydrostatic
Drive Control Handle - Version 1)
-Typical View



Master Spray Switch
(Located on the Hydrostatic Drive
Control Handle - Version 2)
-Typical View

Set Float to Transom Switch

The Set Float to Transom Switch feature allows the operator to activate Float with the Transom “Down” Switch (located on the Hydrostatic Drive Control Handle).

1. Press and hold the Transom Switch (located on the Hydrostatic Drive Con-

trol Handle) in the UP position to raise the NTB to desired height.



Transom Switch - UP
(Located on the Hydrostatic
Drive Control Handle - Version 1)
-Typical View



Transom Switch - UP
(Located on the Hydrostatic Drive
Control Handle - Version 2)
-Typical View

2. Press the NTB Setup Button (located on the Machine Display Settings Page).

One Tap Transom

The One Tap Transom feature allows the operator to fully raise the transom by pressing the Transom Switch (located on the Hydrostatic Drive Control Handle) UP once, to raise the entire lift.

1. Press the NTB Setup Button (located on the Machine Display Settings Page).

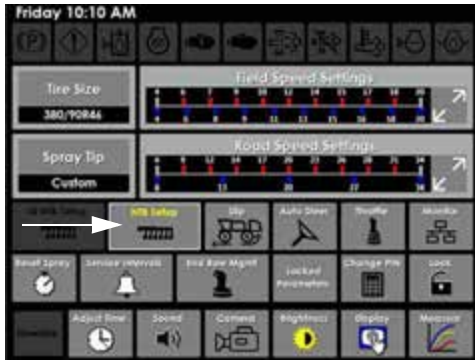

NTB Setup Button
(Located on the Machine Display Settings Page)

3. On the “NTB Adjustments” screen, press EDIT (next to Float With Transom Down).



NTB Adjustments Screen

4. Press YES to operate Float with the Transom Down Switch, then press OK.

NOTE: Press NO to set Float back to operating with the Master Spray Switch.

5. Press OK.
6. Float will now be activated when the Transom “Down” Switch is pressed.

Transom Switch (Up/Down) (Default Setting)

To raise or lower the entire lift, the Transom Switch (located on the Hydrostatic Drive Control Handle) must be held in the UP or DOWN positions until desired height is reached.

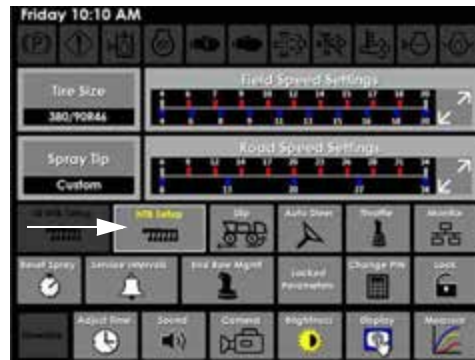

NTB Setup Button
(Located on the Machine Display Settings Page)

2. On the “NTB Adjustments” screen, press EDIT (next to One Tap Transom Up).



NTB Adjustments Screen

3. Press YES to raise entire lift with one tap of the Transom Up Switch, then press OK.

NOTE: Press NO to require the Transom Up Switch to be held the entire time that the cylinders are raising the transom.

4. Press OK.

NTB Override Timer

The override timer controls how long the outer sections raise with the transom during Float operation.

1. Press the NTB Setup Button (located on the Machine Display Settings Page).



NTB Setup Button
(Located on the Machine Display Settings Page)

2. On the “NTB Adjustments” screen, press EDIT (next to NTB Override Timer).



NTB Adjustments Screen

3. Enter desired value (ranging from 100 to 10,000 milliseconds), then press OK.
4. Press OK.

APPLICATION

NOTICE

Never attempt to operate the spray system without solution in the tank. Failure to comply will result in severe equipment damage and will void the warranty.

The solution system is a constantly monitored, continuously adjusted computer-controlled system. The cab-mounted digital spray system console receives information from various inputs to help determine gallons per minute (GPM)/liters per minute (l/min) and gallons per acre (GPA)/liters per hectare (l/ha).

NOTE: The spray system console must be programmed for NTB use before operating.

The following information refers to components of the solution system and is not intended to replace the manufacturer’s operating instructions. Please read and understand the information provided in this manual, as well as your machine operator’s manual and spray system console manufacturer’s operation manual before operating.

Refer to the operator’s manual of the machine being used to operate the NTB for information on the following:

- Solution System
- Rinse System
- Foam Marker System

NTB Application

1. Calibrate the Spray System Console (refer to the manufacturer’s operation manual for calibration instructions).
2. Ensure there is adequate amount of solution in the tank.
3. Engage the parking brake.

4. Start the engine.
5. Press the Field/Road Button (located on the Machine Display Home Page) and change the machine's drive state to FIELD mode.

NOTE: The drive state of the machine cannot be changed unless the Hydrostatic Drive Control Handle is in the NEUTRAL position.



Field/Road Button
(Located on the Machine Display Home Page)

NOTE: The selected drive state will illuminate.

6. Press the Main Tank Valve Switch (located on the side console) in the UP (Open) position.
If desired, activate the Agitation Valve Switch (located on the side console).
Press and hold switch UP to increase flow, or DOWN to decrease flow.



Main Tank and Agitation Valve Switches
(Located on the side console)
-Typical View

NOTE: Main Tank Valve status (OPEN or CLOSED) and Agitation Valve pressure are displayed on the Machine Display Home Page - Field Mode. Agitation Valve pressure is also displayed when in Rode Mode.



- Agitation Valve Pressure
- Main Tank Valve Status

Main Tank Valve Status and
Agitation Valve Pressure Indicators
(Located on the Machine Display Home Page - Field Mode)

7. Press the Solution Pump Switch (located on the side console) in the UP (On) position.

NOTICE

Do not allow the Solution Pump to run continuously while the Boom Solution Valve Switches are off. Failure to comply may generate overheating, causing severe pump damage and will void the warranty.



Solution Pump Switch
(Located on the side console)
-Typical View



Master Spray Switch
(Located on the back side of the Hydrostatic
Drive Control Handle - Version 1)
-Typical View

8. Press the Float Button (located on the Machine Display Auxiliary Controls Page) to enable Float operation.

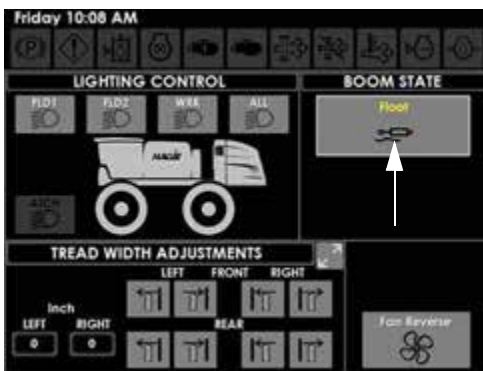

Float Button
(Located on the Machine Display
Auxiliary Controls Page)



Master Spray Switch
(Located on the Hydrostatic Drive
Control Handle - Version 2)
-Typical View

9. Press the Master Spray Switch (located on the Hydrostatic Drive Control Handle) to the ON position.

NOTE: When the Master Spray Switch is ON, a Master Spray Indicator (located on the Machine Display Home Page - Field Mode) will illuminate.

and Agitation Valve Switches until solution is refilled.



Master Spray Indicator
(Located on the Machine Display
Home Page - Field Mode)

10. Press the individual Boom Solution Valve Switches (located on the side console) to the ON position.

NOTE: Each Boom Solution Valve Switch is equipped with an indicator light and will illuminate when the corresponding Boom Solution Valve is OFF.



Boom Solution Valve Switches
(Located on the side console)
-Typical View

NOTE: Number of sections available will depend on the number of section valves equipped on your NTB.

11. Slowly move the Hydrostatic Drive Control Handle forward to obtain desired ground speed.
12. Frequently observe the pressure gauge. If the pressure drops to zero or the spray pattern deteriorates, turn OFF the Master Spray, Solution Pump, Main Tank Valve,



SECTION 4 – MAINTENANCE AND STORAGE

SERVICE - LUBRICATION

Perform grease point inspection/application as recommended in the following information. Apply grease (such as Mobilgrease XHP™ 220-Series) as required.

NOTICE

Failure to properly lubricate pivot and friction points may result in unnecessary wear and damage.

Grease Points (Zerks) - 30/40' NTB

Lubricate the following Grease Points weekly, or as needed.



- **30' NTB:** Four (4) Grease Points (A and B) - two (2) per side.
- **40' NTB:** Six (6) Grease Points (A, B, and C) - three (3) per side.

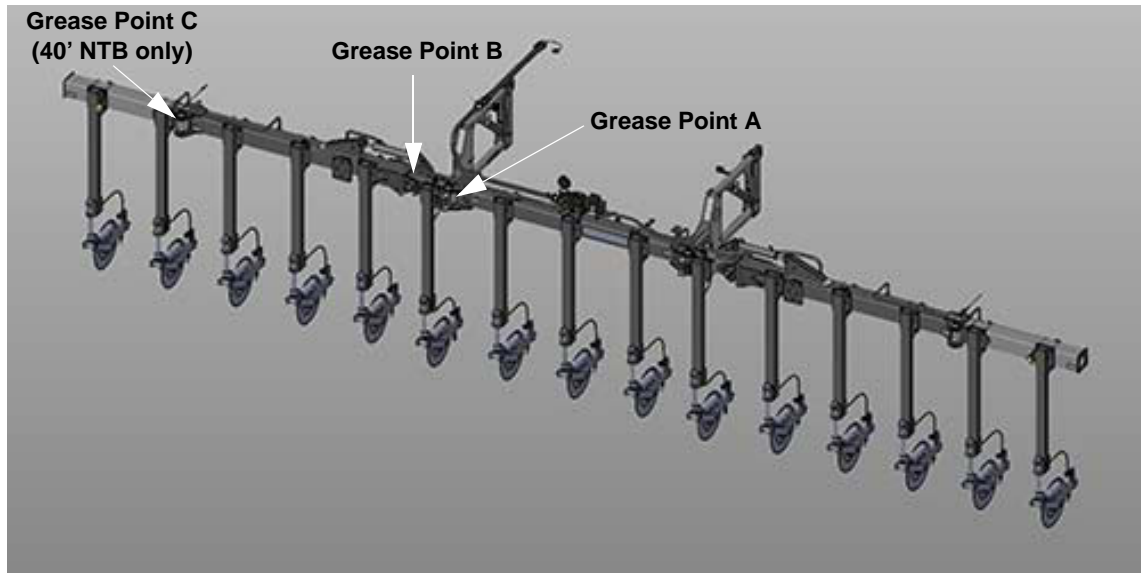

30/40' NTB Grease Points
-Typical View
* 40-ft. NTB shown

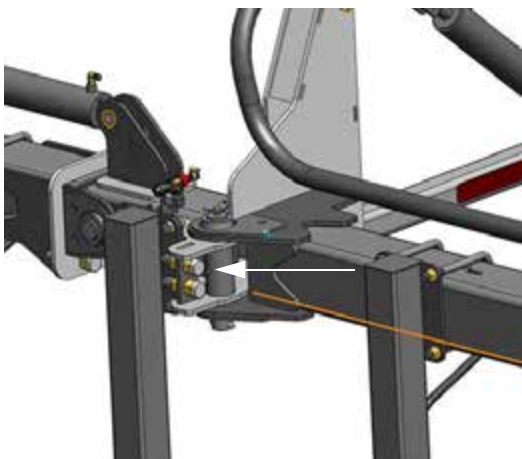

Grease Point A
(Main Fold)

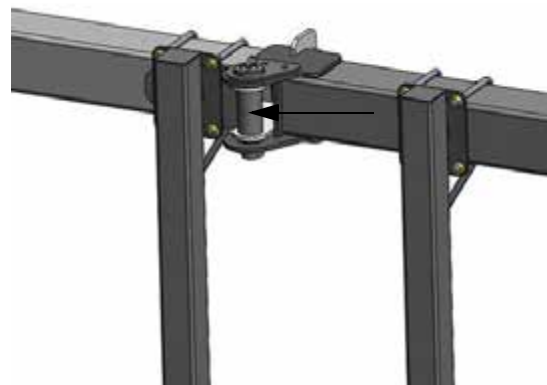

Grease Point C
(Outer Fold)
* 40-ft. NTB only

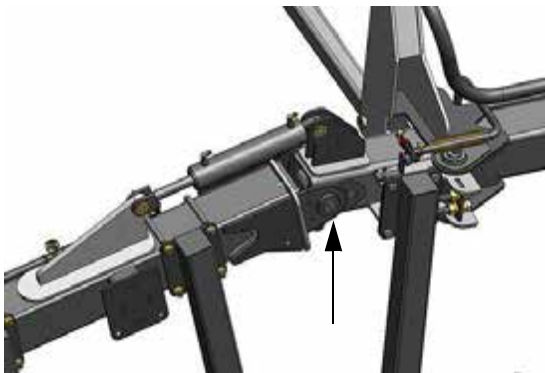

Grease Point B
(Inside Fold)

Grease Points (Zerks) - 60' HsTB

Lubricate the following Grease Points weekly, or as needed.



- Sixteen (16) Grease Points (A, B, and C) - eight (8) per side.
- Six (6) Gauge Wheel Grease Points (D) - three (3) per side.

NOTE: Lubricate Grease Points A, B, and C weekly. Clean and repack wheel bearings (D) yearly.

NOTICE

Do not over-grease the gauge wheel grease zerks. Damage to seals may result.

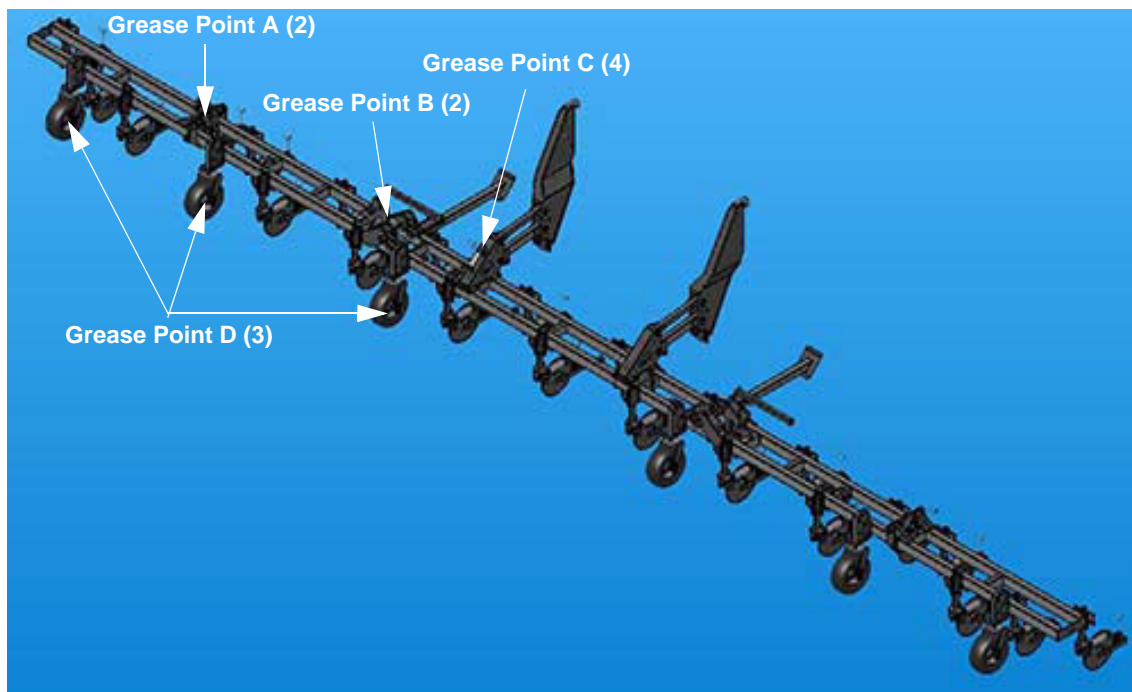

60' HsTB Grease Points
-Typical View

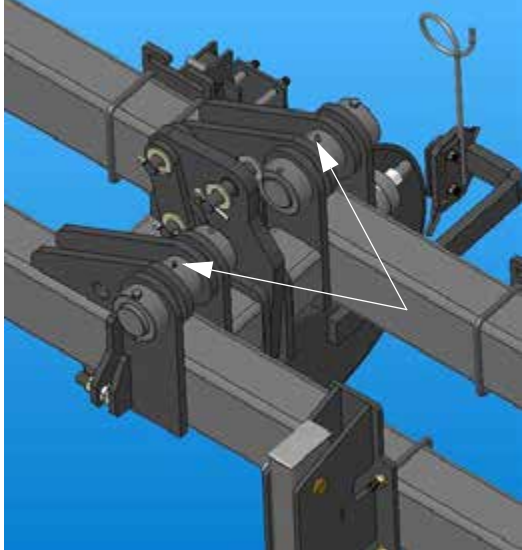

Grease Point A
(Outer Fold)

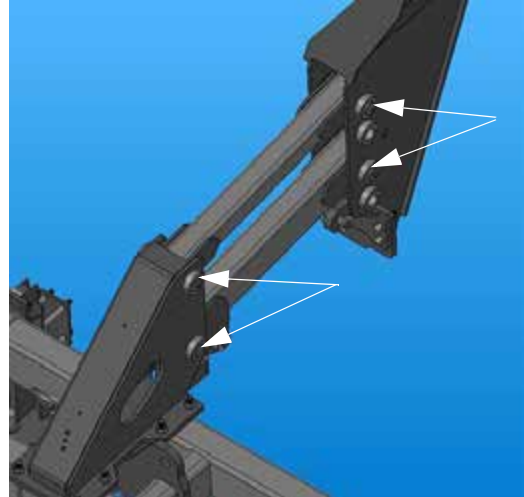

Grease Point C
(Lift Arm)

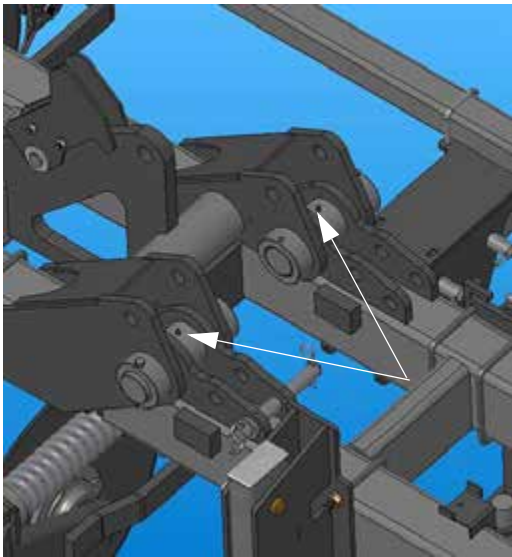

Grease Point B
(Main Fold)

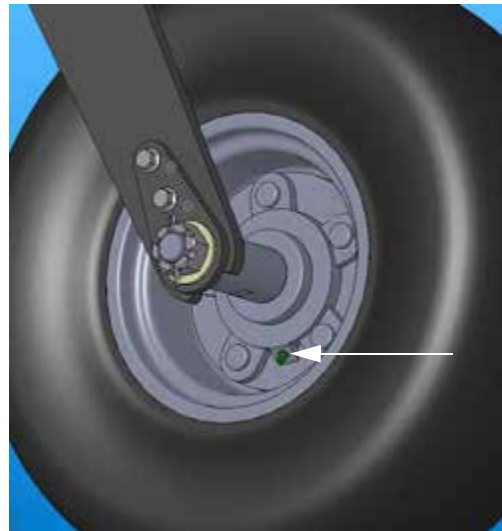

Grease Point D
(Gauge Wheel)

SERVICE - MOUNTING BOLT TORQUE (60' HSTB)

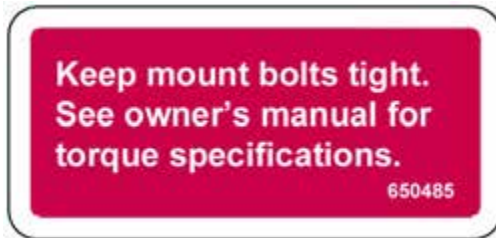

There are eight (8) mounting u-bolts (four on each lift arm head) that mount the toolbar to the lift arms. Re-torque each u-bolt to 150 ft.-lbs. after the first 10 hours of operation. Re-torque again after the next 50 hours of operation. Thereafter, check u-bolt torque yearly.

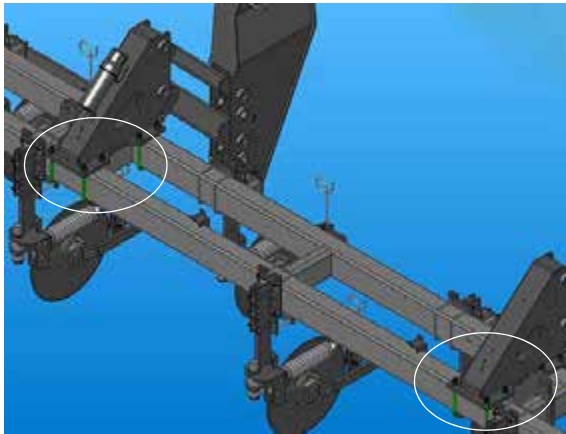

Mounting U-Bolts (8)
(Four u-bolts located on each lift arm head)
-Typical View
* 60' HsTB only

STORAGE

Preparing For Storage

1. Perform lubrication and maintenance inspections, as required.
2. With the engine at normal operating temperature, cycle all hydraulic functions.
3. Thoroughly rinse the spray system.

NOTE: Refer to your machine operator's manual for further information.

4. Thoroughly wash the attachment and touch up any chipped or damaged paint.
5. Replace any damaged or missing decals.

NOTE: Contact Hagie Customer Support for paint touch-up recommendations and decal replacement.

6. Apply multi-purpose grease to hydraulic cylinder rods.
7. Refer to the spray system console manufacturer's operation manual for detailed information on monitor and flow meter storage procedures.
8. If the attachment will be stored separately, ensure that all open ends (e.g. hydraulic, electrical, solution, and foam marker - *if equipped*) are capped or covered with a suitable covering.

Winterization Procedure

To winterize the NTB, it is recommended that you use an environmentally safe type of antifreeze and water mixture that will give you adequate protection to -30° F.

Drain any remaining solution in the system and rinse thoroughly. Run antifreeze mixture through the system until it comes out all attachment openings.

Removal From Storage

1. Remove any dried grease from the cylinder rods and re-apply, if necessary.
2. Thoroughly clean the attachment.
3. Carefully unseal any openings that were sealed for storage.
4. Attach NTB to the sprayer and manually cycle the hydraulics two or three times to adequately lubricate components.



SECTION 5 – MISCELLANEOUS

TRANSPORTING

When driving on a public roadway or elsewhere, be aware of any situation where the machine will be passing near an object with clearance less than the transporting height and width of the overall machine and attachment.

Refer to “Specifications” provided in the *Introduction Section* elsewhere in this manual for dimensions on your model.

WARNING

- Never operate the sprayer on a public roadway with solution in the tank.
- Never load or unload the sprayer with solution in the tank.
- Stopping the sprayer on trailer ramps may result in the sprayer to tip over.

CAUTION

Ensure there is adequate clearance when transporting the sprayer near an object with clearance less than the transporting height and width of the overall machine and attachment.

CAUTION

Do not transport the machine without the NTB in the fully folded position. Failure to comply may result in injury and/or property damage.

CAUTION

Hagie Manufacturing Company does not recommend any form of transportation other than driving the sprayer. Loading the sprayer onto a trailer may result in sprayer rollover.

CAUTION

DO NOT operate the machine at speeds exceeding 20 mph (32 km/h) with solution in the tank. Operating speeds exceeding 20 mph (32 km/h) with a fully loaded tank may result in tire blow-out or wheel hub damage and will void the warranty.

Parking Stands

(60' HsTB only)

WARNING

Ensure the parking stands are in the extended (down) position when storing the attachment. Failure to comply may result in injury and/or property damage.

NOTICE

Ensure the parking stands are in the retracted (up) position when operating or transporting the attachment. Failure to comply may result in property damage.

Your 60' HsTB is equipped with Parking Stands, which support the attachment during storage. Ensure the stands are in the extended (down) position before disconnecting attachment from the machine.



To Retract (Raise) the Parking Stands

1. Remove the Parking Stand Hairpin and Mounting Pin from the bottom hole opening (located near the top of the Parking Stand).

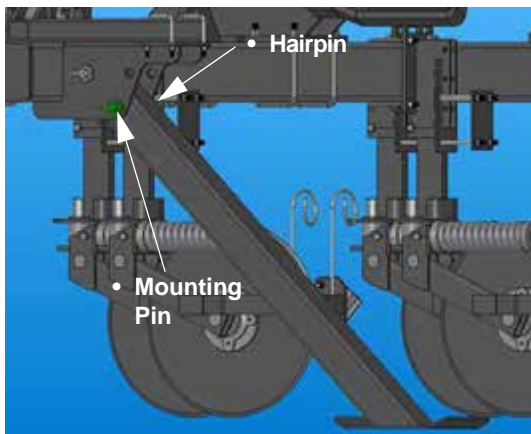

Parking Stand Hairpin/
Mounting Pin Assembly
(Located near the top of the parking stand)
-Typical View

2. Raise the Parking Stand and reinstall the Mounting Pin through the top hole opening, as shown in the following illustration.

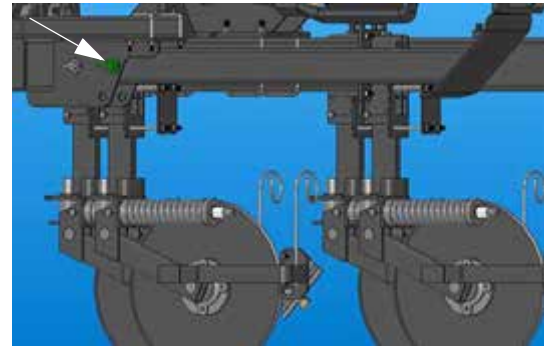

Parking Stand
(Retracted position shown)
-Typical View

3. Reinstall Hairpin.
4. Repeat Steps 1-3 on opposite side of attachment.

To Extend (Lower) the Parking Stands

Repeat previous Steps 1-4 in reverse order to extend the Parking Stands.

Locking the Main Fold Sections for Transport/Storage

(60' HsTB only)

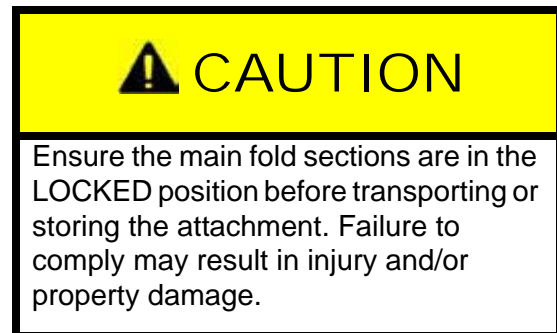

To Lock the Main Fold Sections

1. Fold in the outer and main fold sections of the toolbar.
Refer to “Fold Procedure” provided in *Section 3 - Operating Your NTB* elsewhere in this manual for further information.
2. Remove the Main Fold Lock Pin (located on the front side of toolbar near the main fold point) from the first hole opening.



Main Fold Lock Pin
(Located on the front side of toolbar near the main fold point - "Field/Unlocked Position" shown)
-Typical View

3. Reinstall the Main Fold Lock Pin into the second hole opening (adjacent to the first hole opening on the front side of toolbar near the main fold point).

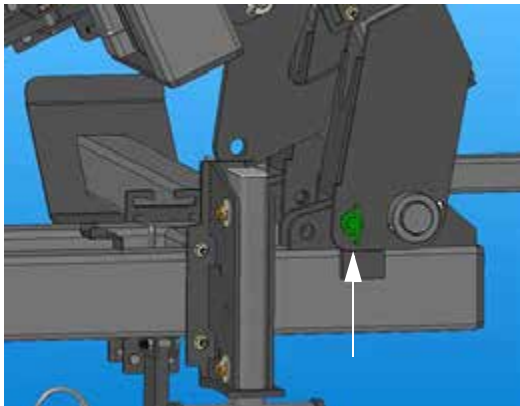

Main Fold Lock Pin
(Located on the front side of toolbar near the main fold point - "Transport-Storage/Locked Position" shown)
-Typical View

4. Repeat Steps 1-3 on opposite side of machine.

To Unlock the Inner Wings

Repeat previous Steps 1-4 in reverse order to unlock the inner wings.

GAUGE WHEEL ADJUSTMENT

Storage to Field Position

1. Ensure the NTB is in the RAISED position.
2. Remove the two (2) Cotter Pins (located on the side of the gauge wheel mounting plate) and set aside.
3. Remove the two (2) Clevis Pins (located on the side of the gauge wheel mounting plate) and set aside.

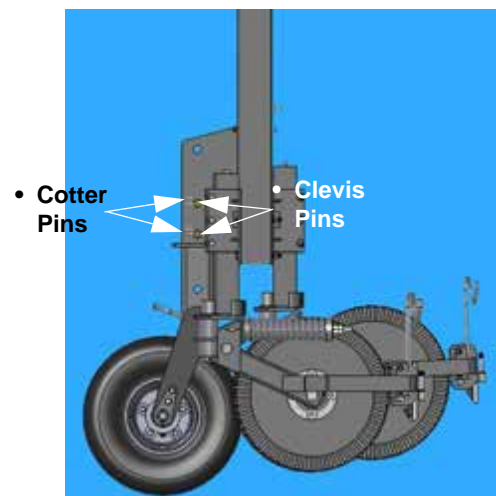

Cotter/Clevis Pin Assembly
(Located on the side of the gauge wheel mounting plate)
-Typical View

4. Firmly grasp the Lift Handle (located above gauge wheel) and lift gauge wheel UP.



Lift Handle
(Located above gauge wheel)
-Typical View

5. Align holes and reinstall previously removed Clevis Pins and Cotter Pins into the top and bottom holes.
6. Repeat steps for additional gauge wheels.

Field to Storage Position

Reverse previous steps to lower the gauge wheels to storage position.



Gauge Wheel
(Field position shown)
-Typical View

COULTER ADJUSTMENT

Adjusting Coulters Tension

When the coulters are not engaging the ground properly, the coulters may need to be compressed to apply down pressure.

- Using a wrench or socket, loosen or tighten Adjustment Nut (located on the end of each coulters spring).
 - Loosen nut for less down pressure.
 - Tighten nut for more down pressure.



Adjustment Nut
(Located on the end of each coulters spring)
-Typical View

Adjusting the Coulters

- Loosen the three (3) Mounting Bolts (located on the side of the coulters mounting plate).



Mounting Bolts
(Located on the side of the
coulters mounting plate)
-Typical View

- Raise or lower coulters to desired height.
- Re-tighten the Mounting Bolts.
- Repeat steps on additional coulters.

QUICK-TACH SYSTEM

Connecting the NTB

WARNING

When connecting or disconnecting the attachment, observe the following safety precautions:

- Monitor both sides of the attachment during fold procedure.
- Select a safe area that is solid and level before unfolding/folding the attachment.
- Clear area of personnel.
- Check for overhead obstructions.
- Do not unfold or fold attachment near power lines. Contact with power lines can result in serious injury or death.

WARNING

Turn the engine OFF before connecting/disconnecting any hoses or electrical lines. Failure to comply may result in serious injury or death.

1. Square up to the NTB attachment.
2. Disengage the Quick-Tach Lock Assemblies by pulling the Lock Pin (located on the front left and right-hand side of machine) OUT as far as it will go until it is in the “lock-out” position.

NOTE: “Lock-out” position prevents re-locking while attaching or detaching the NTB.



Lock Pin
(Located on the front left and right-hand side of machine)
-Typical View

** Disengaged position shown*

3. Lower the machine by rotating the corresponding Air Suspension Valves (located on the left-hand front and rear air bags) in the COUNTER-CLOCKWISE (Deflate) position.

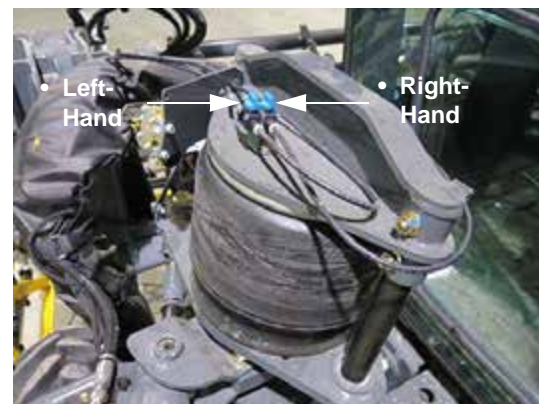

Air Suspension Valves
(Located on the left-hand front and rear air bags)
-Typical View

** Front left-hand air bag shown*

4. Slowly pull machine into NTB attachment, ensuring the Attachment Hooks are high enough to clear the mounting pins.



Attachment Clearing Mounting Pins
-Typical View

5. Raise the machine by rotating the corresponding Air Suspension Valves in the CLOCKWISE (Inflate) position.
6. Engage the parking brake.
7. **Turn the engine OFF before connecting any hoses or electrical lines.**
8. Connect all Solution, Foam Marker (if equipped), Hydraulic and Electrical lines.

Solution Connection (Dry Mate)

- Install Solution Connections together.
- Push both Solution Connection Cam Lock Levers in the DOWN position.
- Rotate the bottom Solution Connection Valve in the fully COUNTER-CLOCKWISE (Open) position.
- Rotate the top Solution Connection Valve in the fully COUNTER-CLOCKWISE (Open) position.

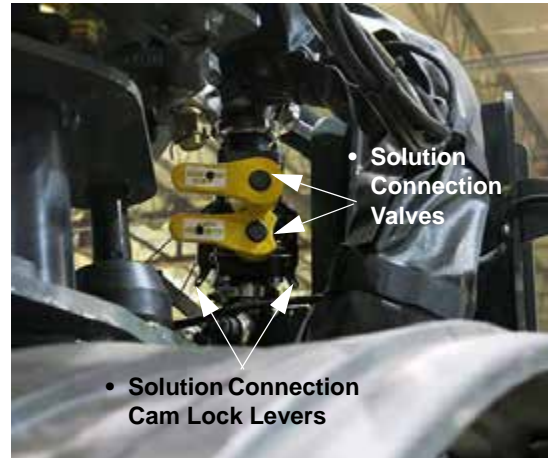

Solution Connection Valves
and Cam Lock Levers
(Located on the front
right-hand side of machine)
-Typical View

* View shown from behind front right-hand wheel

Foam Marker Connection -If Equipped



Foam Marker Connection
(Located on front
right-hand side of machine)
-Typical View

Hydraulic and Electrical Connections (Quick Connect Multi-Coupler)

- Install the Hydraulic/Electrical Connections (located on the left-hand side of attachment) into the Multi-Coupler Receptacle (located on front left-hand side of machine), ensuring full engagement.

- Push the Quick Connect Handle (located on the Hydraulic/Electric Multi-Coupler Assembly) UP to engage hydraulic/electrical connections.



Hydraulic/Electric Multi-Coupler Assembly
(Located on the front left-hand side of machine)
-Typical View

9. Start the engine.
10. Raise the NTB attachment until the Attachment Hooks fully engage.

NOTE: Raising the attachment will allow the weight of the NTB to pull the Attachment Hooks over the Mounting Pins. You will notice a change of weight as the machine begins to support the attachment.



-Typical View

11. Engage the Quick-Tach Lock Assemblies by pushing the Lock Pins IN, ensuring full engagement.



Lock Pin
-Typical View
* Engaged position shown

60' HsTB

12. Retract (raise) the parking stands and ensure the main fold sections are in the UNLOCKED position before unfolding the attachment.
Refer to “Transporting” provided elsewhere in this section for further information.

Disconnecting the NTB

 **WARNING**

Turn the engine OFF before connecting/disconnecting any hoses or electrical lines. Failure to comply may result in serious injury or death.

 **WARNING**

Ensure NTB attachment is in the fully FOLDED position before detaching from machine. Failure to comply may result in serious injury or death and will result in property damage.

Before disconnecting the NTB, determine a proper storage location. When choosing a place to store the attachment, there are three important things to keep in mind:

Is the ground level?

The ground must be level to help prevent the attachment from falling over. Level ground will also minimize stress on the frame of the attachment while in storage and ease of attachment hook-up.

Is there enough space?

The NTB must be folded for it to stand properly. Be aware of the room that is needed for the attachment and adequate space to travel around it safely.

Is it accessible?

The NTB must to be positioned so you can connect the attachment easily. If temporarily storing the attachment on a soft surface (such as grass), it is recommended to put blocks or wood beneath the coulters (and parking stands, if equipped with a 60-ft. HsTB) to prevent the attachment from sinking into the ground.

NOTE: It is NOT recommended to store the NTB attachment on a soft surface for an extended period of time, due to the risk of settling soil, even when blocks or wood are used.

1. Lower the NTB attachment down to level storage location.

 **WARNING**

Lower NTB to the ground before disengaging the Quick-Tach Lock Assemblies.

60' HsTB

NOTE: If you are disconnecting a 30/40' NTB, proceed to Step 2.



- Extend (lower) the parking stands. Refer to “Transporting” provided elsewhere in this section for further information.
- Lower attachment, ensuring gauge wheels touch the ground first and toolbar leans back slightly. (This will aid in reconnecting the attachment).

2. Disengage the Quick-Tach Lock Assemblies by pulling the Lock Pin (located on the front left and right-hand side of machine) OUT as far as it will go until it is in the “lock-out” position.

NOTE: “Lock-out” position prevents re-locking while attaching or detaching the NTB.



Lock Pin
(Located on the front left and
right-hand side of machine)
-Typical View
** Disengaged position shown*

3. Lower the machine by rotating the corresponding Air Suspension Valves (located on the left-hand front and rear air bags) in the COUNTER-CLOCKWISE (Deflate) position.

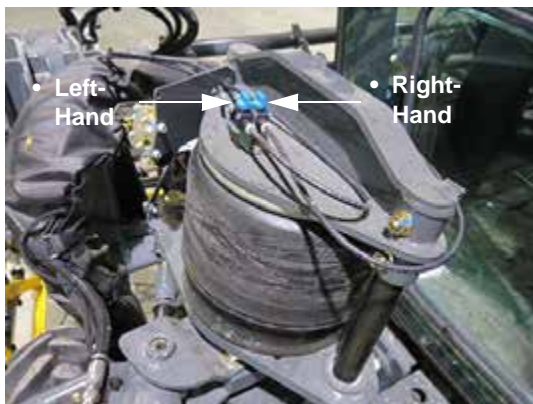

Air Suspension Valves
(Located on the left-hand
front and rear air bags)
-Typical View
** Front left-hand air bag shown*

4. Ensure the Boom Solution Valve Switches (located on the side console) are in the OFF position.



Boom Solution Valve Switches
(Located on the side console)
-Typical View

5. Engage the parking brake.
6. **Turn the engine OFF before disconnecting any hoses or electrical lines.**
7. Disconnect all Solution, Foam Marker (if equipped), Hydraulic, and Electrical lines, ensuring not to leave the ends in a place where they may become damaged or contaminated.

Solution Connection (Dry Mate)

-If Equipped

- Rotate the top Solution Connection Valve in the fully CLOCKWISE (Close) position.
- Rotate the bottom Solution Connection Valve in the fully CLOCKWISE (Close) position.
- Lift the Solution Connection Cam Lock Levers in the UP position to disengage the solution connections.
- Install provided dust caps on the solution connection openings.

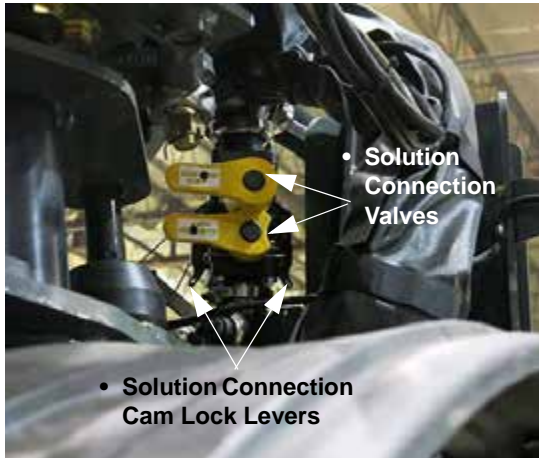

Solution Connection Valves
and Cam Lock Levers
(Located on the front
right-hand side of machine)
-Typical View

* View shown from behind front right-hand wheel

- Remove the Hydraulic/Electrical Connections from the Multi-Coupler Receptacle (located on front left-hand side of machine).



Hydraulic/Electric Multi-Coupler Assembly
(Located on the front
left-hand side of machine)
-Typical View

Foam Marker Connection

-If Equipped



Foam Marker Connection
(Located on front
right-hand side of machine)
-Typical View

8. If no other attachment is going to be installed, re-lock the Quick-Tach Lock Assemblies by pushing the Lock Pins IN.



Lock Pin
-Typical View

* Engaged position shown

Hydraulic and Electrical Connections (Quick Connect Multi-Coupler)

- Pull the Quick Connect Handle (located on the Hydraulic/Electric Multi-Coupler Assembly) DOWN to disengage hydraulic/electrical connections.

NOTE: Install provided covers/caps on disconnection points to avoid damage and contamination. If necessary, cover the opening with a plastic bag (secured with tape). Contact Hagie Customer Support for replacement covers.

9. Start the engine.
10. Disengage the parking brake and slowly back away from the attachment.



-Typical View

11. Raise the machine by rotating the corresponding Air Suspension Valves in the CLOCKWISE (Inflate) position.



INDEX

2015 Product Warranty	1-10
A Word From Hagie Manufacturing	
Company	1-1
About This Manual	1-1
Application	3-9
Coulter Adjustment	5-4
Float Operation	3-6
Fold Procedure	3-1
Gauge Wheel Adjustment	5-3
Intended Use	2-1
Quick-Tach System	5-5
Reporting Accidents, Injuries, or Safety	
Concerns	1-3
Safety Decals	2-3
Safety Messages Used In This Manual	1-2
Safety Precautions	2-1
Service - Lubrication	4-1
Service -	
Mounting Bolt Torque (60' HsTB)	4-5
Service and Assistance	1-3
Specifications	1-4
Storage	4-5
Transporting	5-1

