



**PARTS MANUAL  
FOR  
HAGIE STS NITROGEN TOOLBAR**

**HAGIE MANUFACTURING COMPANY**

721 CENTRAL AVENUE WEST  
BOX 273  
CLARION, IOWA 50525-0273

(515) 532-2861

COVERS MACHINE SERIAL NUMBERS: U6911001001 thru U6911001100  
U6921001001 thru U6921001100  
U6951001001 thru U6951001100  
U6961001001 thru U6961001100

06-09 493484  
02-15

To obtain the most current parts manual for your machine, please visit [www.hagiehelp.com](http://www.hagiehelp.com).

© 2009, 2015 Hagie Manufacturing Company. Clarion, Iowa USA

## NITROGEN TOOLBAR IDENTIFICATION

Each Hagie toolbar is identified by means of a frame serial number. This serial number denotes the model, the year in which it was built, and the number of the toolbar. To insure prompt, efficient service when ordering parts or requesting service repairs from Hagie Manufacturing Company, record the serial number in the space provided below.

NOTE: Reference to left hand and right hand used throughout this manual refers to the position when seated in the operator's seat facing forward.

This manual is not intended to be a complete guide for machine maintenance and repairs. If you are not properly trained to perform service on this machine, contact Hagie Customer Support for assistance. Improper maintenance or repair may result in property damage, personal injury, or death.

NITROGEN TOOLBAR SERIAL NUMBER

---

TABLE OF CONTENTS

30FT TOOLBAR ASSEMBLY . . . . .	.4-7
40FT TOOLBAR ASSEMBLY . . . . .	8-11
ROW UNIT ASSEMBLY . . . . .	12
BUMPER ASSEMBLY . . . . .	13
FOAMER DROP AND HOSE ASSEMBLY . . . . .	14
QUICK ATTACH BRACKETS . . . . .	15
30FT TOOLBAR CONTROL VALVE ASSEMBLY . . . . .	16
40FT TOOLBAR CONTROL VALVE ASSEMBLY . . . . .	17
FLOW METER ASSEMBLY . . . . .	18
SOLUTION CONTROL VALVE ASSEMBLY . . . . .	19
SOLUTION HOISING . . . . .	.20-23
HYDRAULIC SCHEMATIC . . . . .	.24-27
WIRING DIAGRAM. . . . .	.28-29

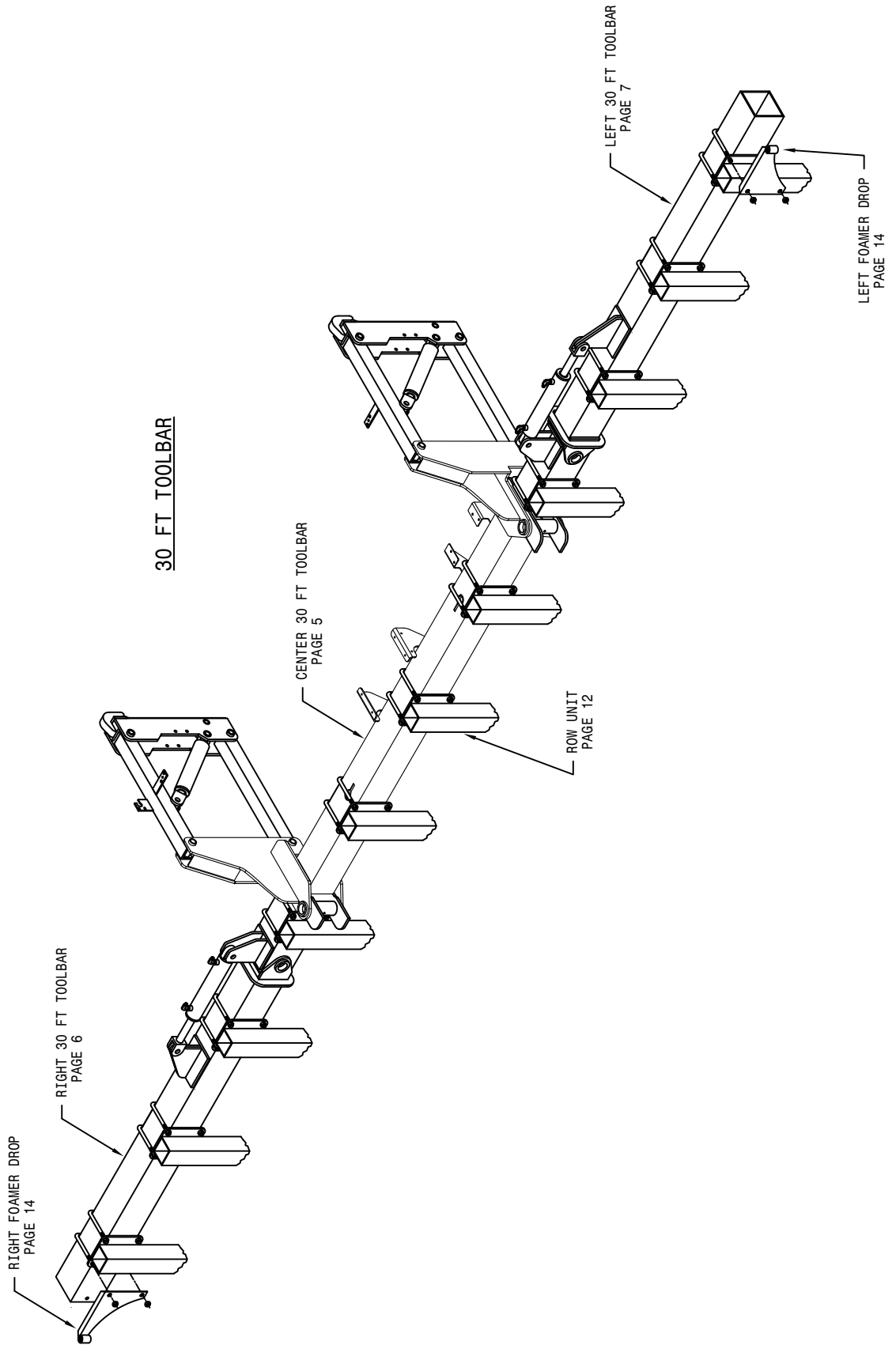

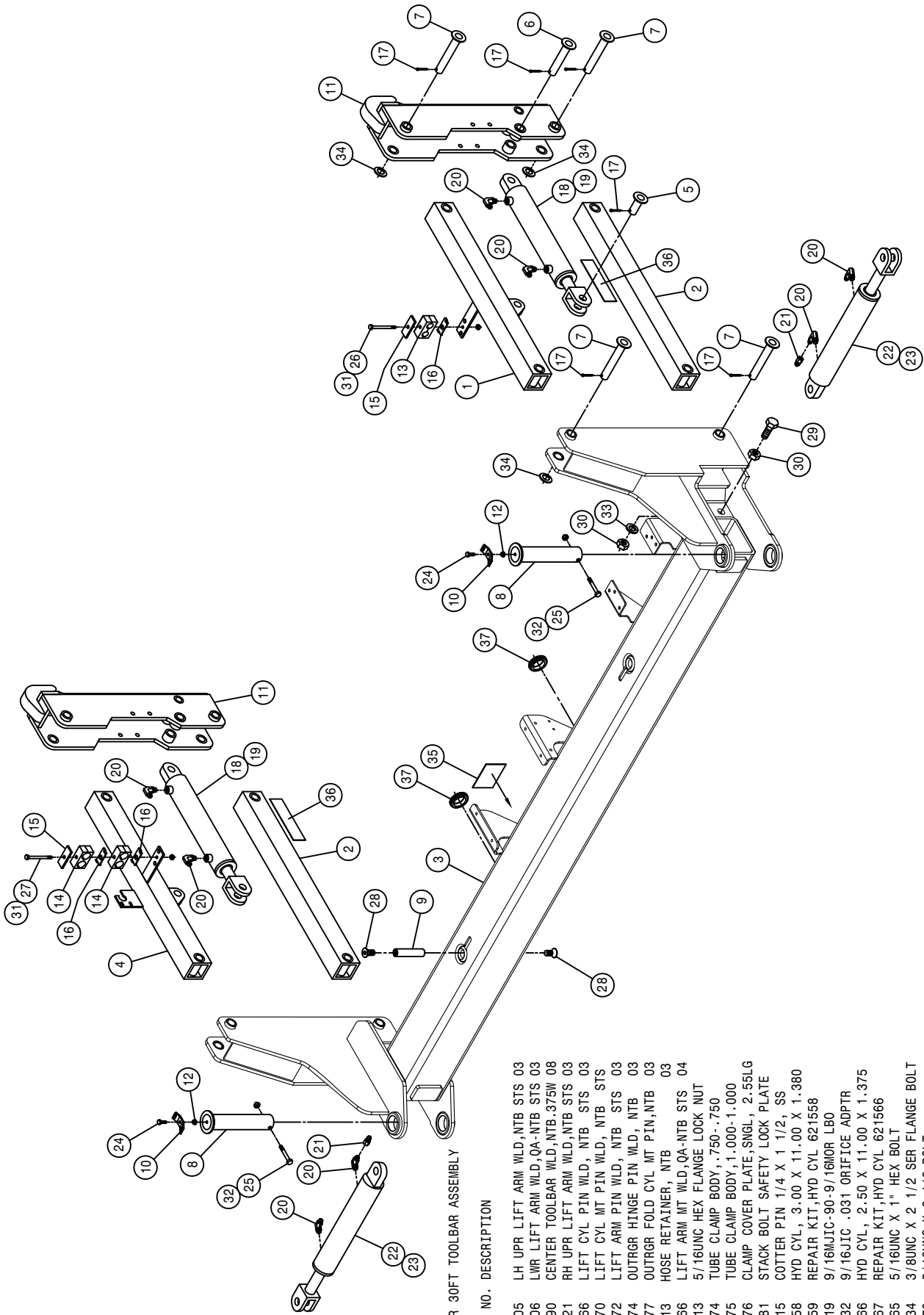

CENTER 30FT TOOLBAR ASSEMBLY

DET.	QTY	PART NO.	DESCRIPTION
1	1	439005	LH UPR LIFT ARM WLD, NTB STS 03
2	2	439006	LWR LIFT ARM WLD, OA-NTB STS 03
3	1	439290	CENTER TOOLBAR WLD, NTB .375W 08
4	1	439021	RH UPR LIFT ARM WLD, NTB STS 03
5	2	439066	LIFT CYL PIN WLD, NTB STS 03
6	2	439070	LIFT CYL MT PIN WLD, NTB STS
7	8	439072	LIFT ARM PIN WLD, NTB STS 03
8	2	439074	OUTRGR HINGE PIN WLD, NTB 03
9	2	439077	OUTRGR FOLD CYL MT PIN, NTB 03
10	2	439113	HOSE RETAINER, NTB 03
11	2	439166	LIFT ARM MT WLD, OA-NTB STS 04
12	2	470113	5/16UNC HEX FLANGE LOCK NUT
13	1	470274	TUBE CLAMP BODY, .750-.750
14	2	470275	TUBE CLAMP BODY, 1.000-1.000
15	2	470276	CLAMP COVER PLATE, SNGL, 2.55LG
16	3	470281	STAKE BOLT SAFETY LOCK PLATE
17	12	475015	COTTER PIN 1/4 X 1 1/2, SS
18	2	621558	HYD CYL, 3.00 X 11.00 X 1.380
19	2	621559	REPAIR KIT, HYD CYL 621558
20	8	618119	9/16MUNC-90-9/16MOR LBO
21	2	618732	9/16JIC .031 ORIFICE ADPTR
22	2	621566	HYD CYL, 2.50 X 11.00 X 1.375
23	2	621567	REPAIR KIT, HYD CYL 621566
24	2	900065	5/16UNC X 1" HEX BOLT
25	2	900134	3/8UNC X 2 1/2 SER FLANGE BOLT
26	1	900070	5/16UNC X 2 1/2 BOLT
27	1	900075	5/16UNC X 3 3/4 HEX BOLT
28	4	900393	5/8UNC X 1" FLT SOC CAP SCR
29	4	900534	1" UNC X 3" HEX BOLT
30	8	910017	1-8 HEX NUT
31	2	914002	5/16UNC HEX STOVER NUT
32	2	914004	3/8UNC HEX STOVER NUT
33	4	920508	1" LOCK WASHER
34	8	920008	1" SAE FLAT WASHER
35	1	650137	DECAL, DANGER, NTB DISCONNECT, 5"
36	2	650219	DECAL, DANGER, NTB DISCONNECT, 10"
37	2	470552	GROMMET, 1.75ID .250GW 2.00GD

RIGHT 30FT TOOLBAR ASSEMBLY

DET. QTY PART NO. DESCRIPTION

1	1	439381	RH OUTRGR ARTICULAR WLD,NTB,'10
2	1	439040	12R OUTRGR WLD, NTB STS 03
3	1	439066	LIFT CYL PIN WLD, NTB STS 03
4	1	439068	ARTICULATOR CYL PIN WLD,NTB 03
5	1	439074	OUTRGR HINGE PIN WLD, NTB 03
6	2	471005	GREASE ZERK, 1/4 28 X 1/2
7	2	475015	COTTER PIN 1/4 X 1 1/2, SS
8	1	914002	5/16UNC HEX STOVER NUT
9	2	618689	9/16MJ-90-9/16MOR .042 CHK VLV
10	1	621558	HYD CYL, 3.00 X 11.00 X 1.380
11	1	621559	REPAIR KIT, HYD CYL 621558
12	1	900069	5/16UNC X 2" HEX BOLT
13	1	900134	3/8UNC X 2 1/2 SER FLANGE BOLT
14	1	439386	ARTICULATOR FLD CYL PIN,NTB,'10
15	1	914004	3/8UNC HEX STOVER NUT
16	4	900536	1" UNC X 4" HEX BOLT,FULL THD
17	8	910017	1-8 HEX NUT
18	4	920508	1" LOCK WASHER

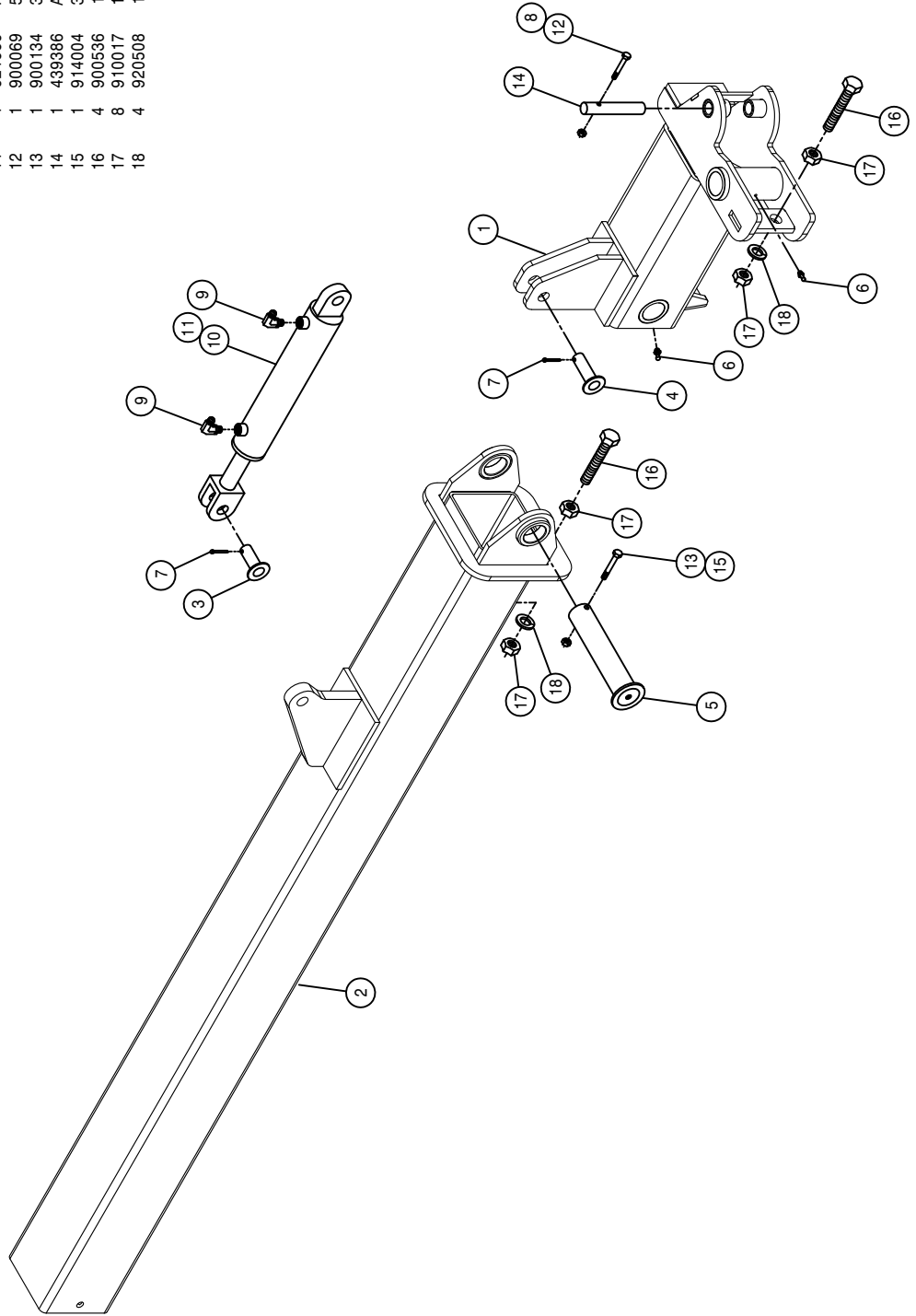

LEFT 30FT TOOLBAR ASSEMBLY

DET.	QTY	PART NO.	DESCRIPTION
1	1	439382	LH OUTRGR ARTICULAR WLD NTB '10
2	1	439040	12R OUTRGR WLD, NTB STS 03
3	1	439066	LIFT CYL PIN WLD, NTB STS 03
4	1	439068	ARTICULATOR CYL PIN WLD, NTB 03
5	1	439074	OUTRGR HINGE PIN WLD, NTB 03
6	2	471005	GREASE ZERK, 1/4 28 X 1/2
7	2	475015	COTTER PIN 1/4 X 1 1/2, SS
8	1	914002	5/16UNC HEX STOVER NUT
9	2	618689	9/16MJ-90-9/16MOR .042 CHK VLV
10	1	621558	HYD CYL, 3.00 X 11.00 X 1.380
11	1	621559	REPAIR KIT, HYD CYL 621558
12	1	900069	5/16UNC X 2" HEX BOLT
13	1	900134	3/8UNC X 2 1/2 SER FLANGE BOLT
14	1	439386	ARTICULATOR FLD CYL PIN, NTB '10
15	1	914004	3/8UNC HEX STOVER NUT
16	4	900536	1" UNC X 4" HEX BOLT, FULL THD
17	8	910017	1-8 HEX NUT
18	4	920508	1" LOCK WASHER

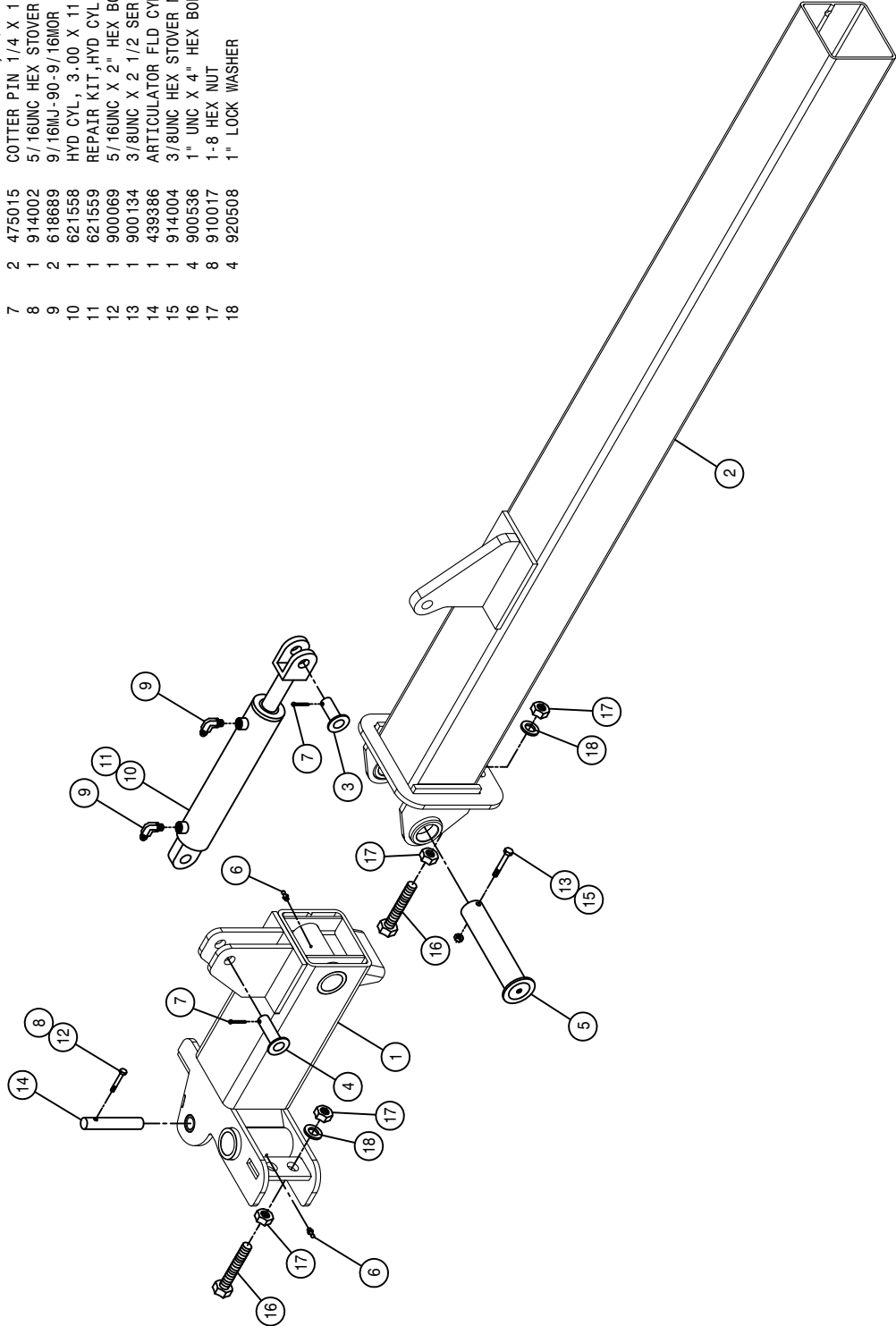

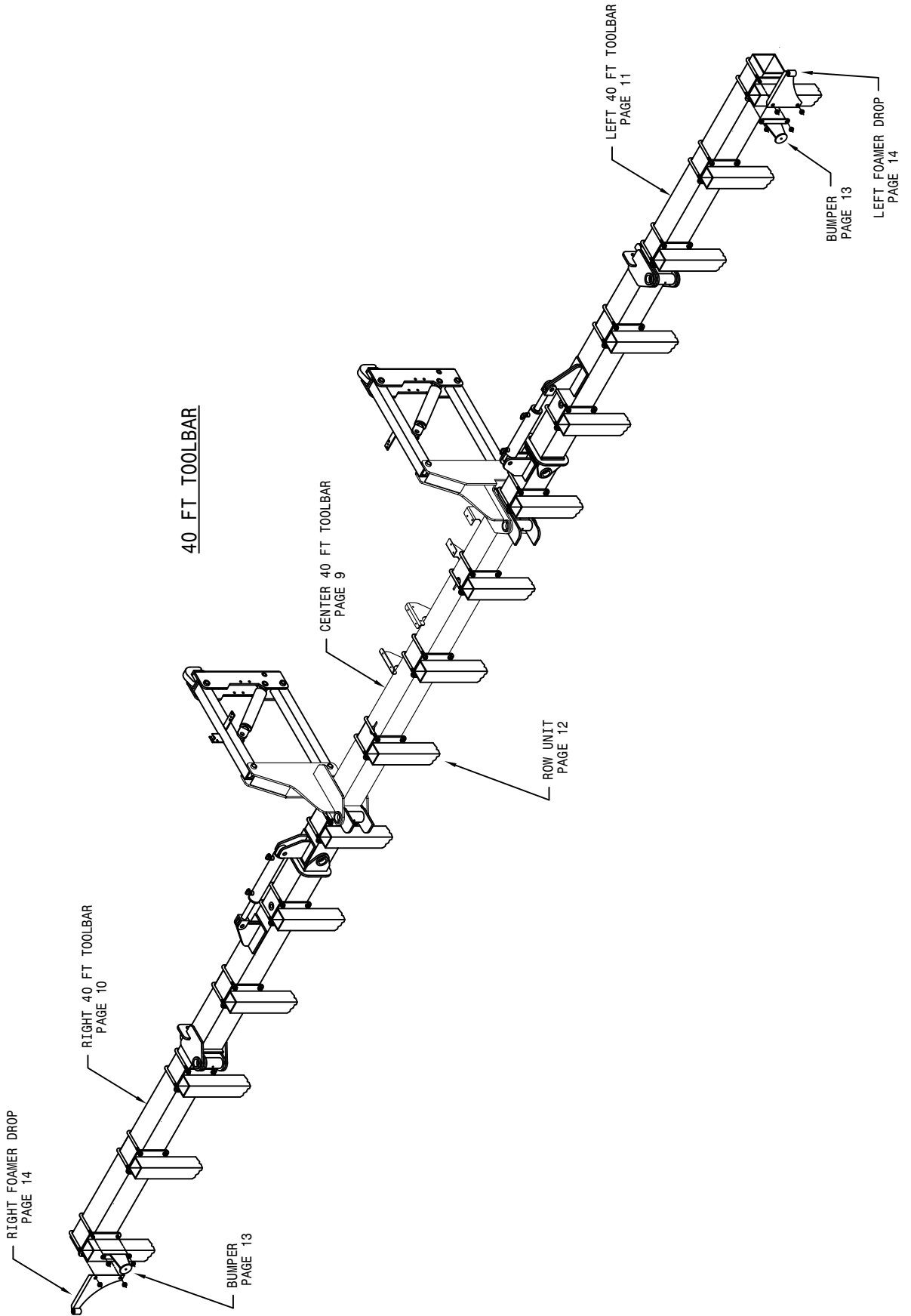



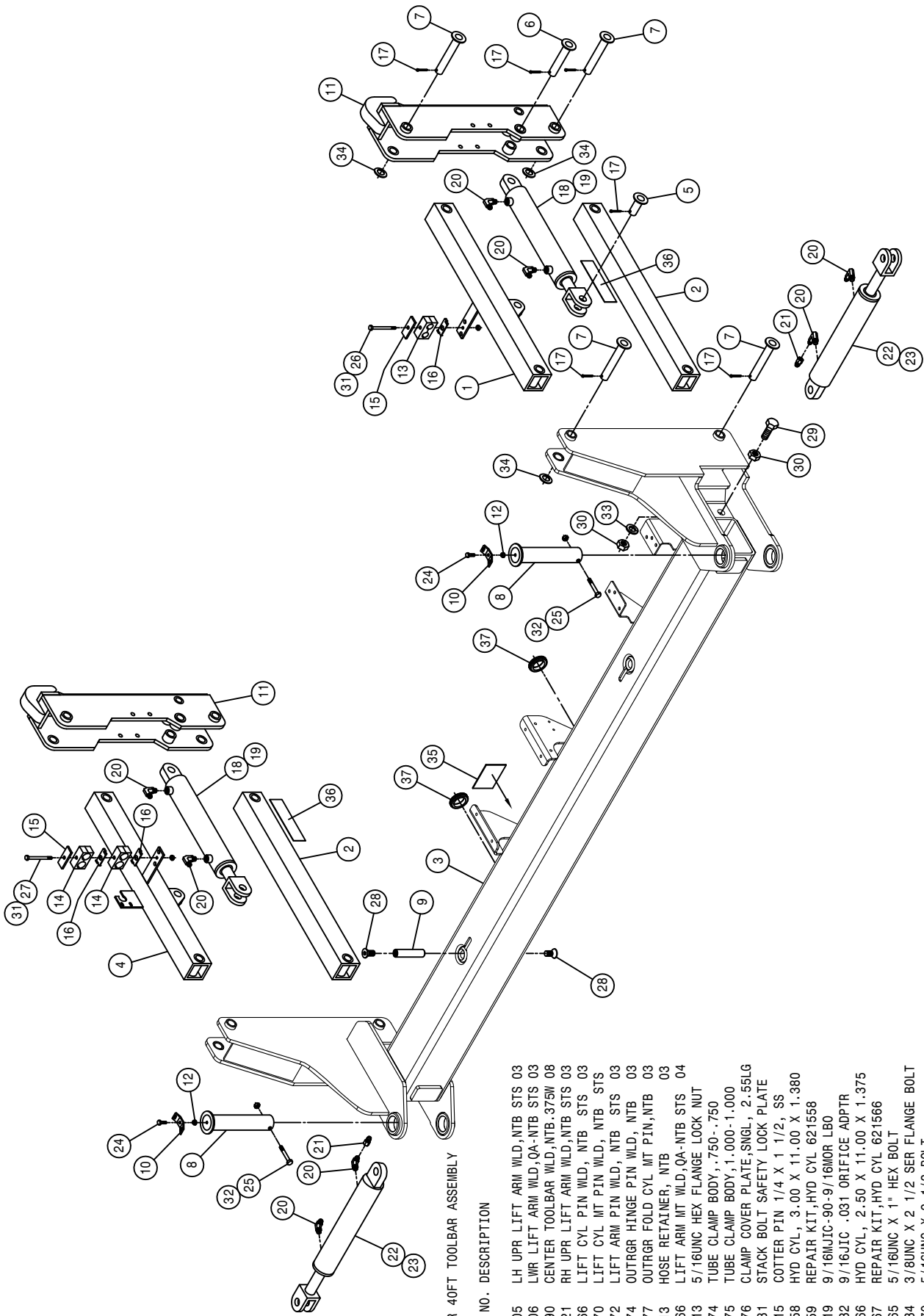

CENTER 40FT TOOLBAR ASSEMBLY

DET.	QTY	PART NO.	DESCRIPTION
1	1	439005	LH UPR LIFT ARM WLD,NTB STS 03
2	2	439006	LWR LIFT ARM WLD,QA-NTB STS 03
3	1	439290	CENTER TOOLBAR WLD,NTB.375W 08
4	1	439021	RH UPR LIFT ARM WLD,NTB STS 03
5	2	439066	LIFT CYL PIN WLD, NTB STS 03
6	2	439070	LIFT CYL MT PIN WLD, NTB STS 03
7	8	439072	LIFT ARM PIN WLD, NTB STS 03
8	2	439074	OUTRGR HINGE PIN WLD, NTB 03
9	2	439077	OUTRGR FOLD CYL MT PIN,NTB 03
10	2	439113	HOSE RETAINER, NTB 03
11	2	439166	LIFT ARM MT WLD,QA-NTB STS 04
12	2	470113	5/16UNC HEX FLANGE LOCK NUT
13	1	470274	TUBE CLAMP BODY, .750-.750
14	2	470275	TUBE CLAMP BODY,1.000-1.000
15	2	470276	CLAMP COVER PLATE,SNGL, 2.55LG
16	3	470281	STACK BOLT SAFETY LOCK PLATE
17	12	475015	COTTER PIN 1/4 X 1 1/2, SS
18	2	621558	HYD CYL, 3.00 X 11.00 X 1.380
19	2	621559	REPAIR KIT,HYD CYL 621558
20	8	618119	9/16MJIC-90-9/16MOR LBO
21	2	618732	9/16JIC .031 ORIFICE ADPTR
22	2	621566	HYD CYL, 2.50 X 11.00 X 1.375
23	2	621567	REPAIR KIT,HYD CYL 621566
24	2	900065	5/16UNC X 1" HEX BOLT
25	2	900134	3/8UNC X 2 1/2 SER FLANGE BOLT
26	1	900070	5/16UNC X 2 1/2 BOLT
27	1	900075	5/16UNC X 3 3/4 HEX BOLT
28	4	900393	5/8UNC X 1" FLT SOC CAP SCR
29	4	900534	1" UNC X 3" HEX BOLT
30	8	910017	1-8 HEX NUT
31	2	914002	5/16UNC HEX STOVER NUT
32	2	914004	3/8UNC HEX STOVER NUT
33	4	920508	1" LOCK WASHER
34	8	920008	1" SAE FLAT WASHER
35	1	650137	DECAL,DANGER,NTB DISCONNECT,5"
36	2	650219	DECAL,DANGER,NTB DISCONNECT,10"
37	2	470552	GROMMET,1.75ID .250GW 2.00GD

RIGHT 40FT TOOLBAR ASSEMBLY

DET. QTY PART NO. DESCRIPTION

1	1	439381	RH OUTGR ARTICULAR WLD NTB'10
2	1	439048	RH 16R OUTGR WLD, NTB STS 03
3	1	439054	OUTGR EXT FOLD SLIDE WLD, NTB
4	8	439058	FOLD SLIDE WEAR STRIP, 16R NTB
5	1	439060	OUTGR EXT FOLD ARM WLD, NTB 03
6	1	439188	OUTER FOLD WELD, N40 05
7	1	439066	LIFT CYL PIN WLD, NTB STS 03
8	1	439068	ARTICULATOR CYL PIN WLD, NTB 03
9	2	439074	OUTGR HINGE PIN WLD, NTB 03
10	1	439077	OUTGR FOLD CYL MT PIN, NTB 03
11	3	439078	ARTICULATOR FOLD CYL PIN, NTB
12	1	439113	HOSE RETAINER, NTB 03
13	17	470113	5/16UNC HEX FLANGE LOCK NUT
14	3	471005	GREASE ZERK, 1/4 28 X 1/2
15	2	475015	COTTER PIN 1/4 X 1 1/2, SS
16	2	618119	9/16MJIC-90-9/16MOR LBO
17	1	618732	9/16JIC .031 ORIFICE ADPTR
18	1	621568	HYD CYL, 2.00 X 18.00 X 1.125
19	1	621569	REPAIR KIT, HYD CYL 621568
20	2	618689	9/16MJ-90-9/16MOR .042 CHK VLV
21	1	621558	HYD CYL, 3.00 X 11.00 X 1.380
22	1	621559	REPAIR KIT, HYD CYL 621558
23	16	900060	5/16UNC X 1" FLT SOC CAP SCR
24	1	900065	5/16UNC X 1" HEX BOLT
25	2	900069	5/16UNC X 2" HEX BOLT
26	2	900134	3/8UNC X 2 1/2 SER FLANGE BOLT
27	2	900393	5/8UNC X 1" FLT SOC CAP SCR
28	2	900534	1" UNC X 3" HEX BOLT
29	12	910017	1-8 HEX NUT
30	2	914004	3/8UNC HEX STOVER NUT
31	4	914002	5/16UNC HEX STOVER NUT
32	6	920508	1" LOCK WASHER
33	1	439192	OUTER FOLD DROP WELD, N40 05
34	8	900334	5/8UNC X 1 3/4 HEX BOLT
35	8	914010	5/8UNC HEX STOVER NUT
36	2	900070	5/16UNC X 2 1/2 BOLT
37	1	439386	ARTICULATOR FLD CYL PIN, NTB'10
38	4	900536	1" UNC X 4" HEX BOLT, FULL THD

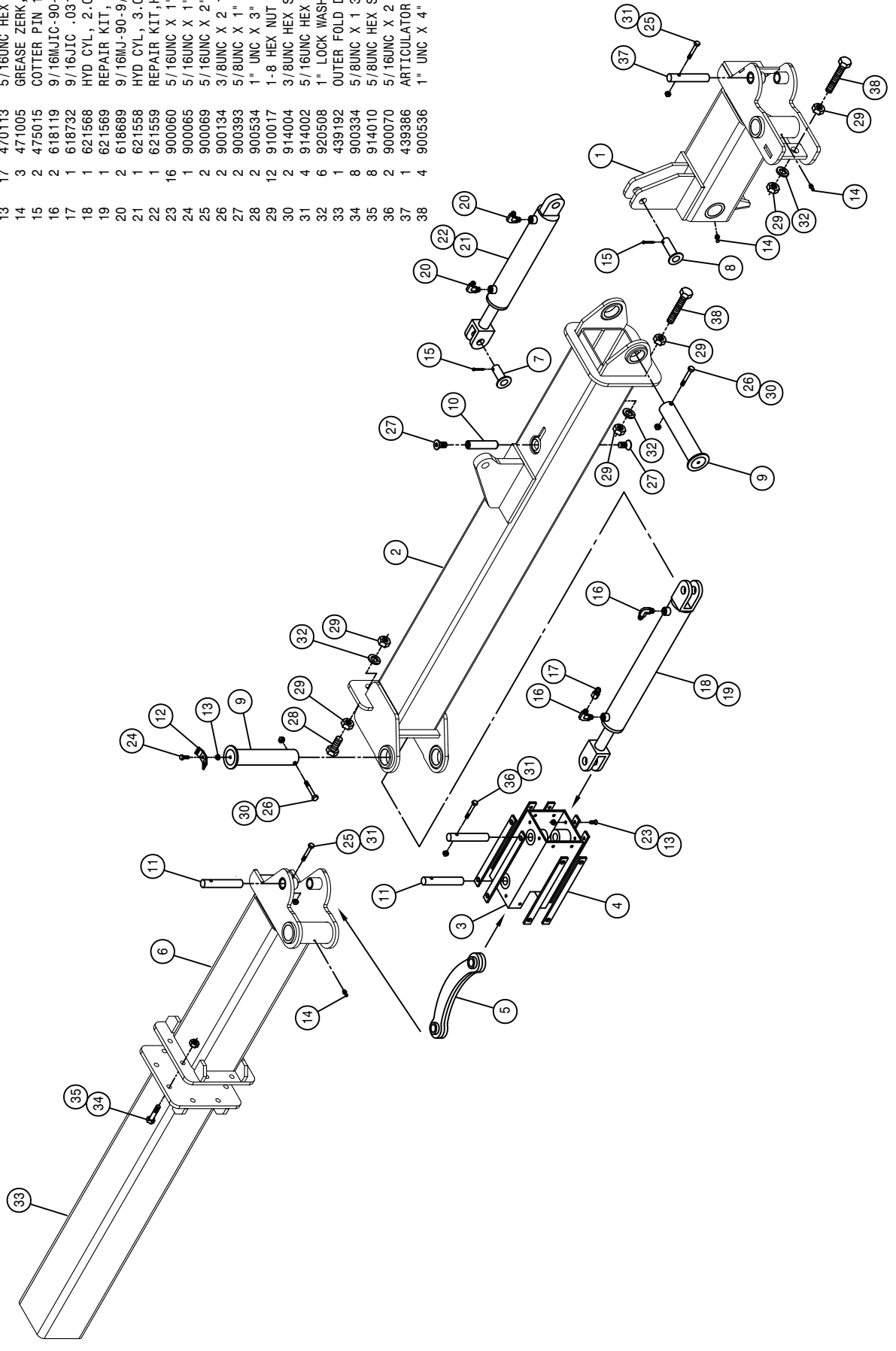

LEFT 40FT TOOLBAR ASSEMBLY

DET. QTY PART NO. DESCRIPTION

1	1	439382	LH OUTGRG ARTICULAR WLD NTB'10
2	1	439049	LH 16R OUTGRG WLD, NTB STS 03
3	1	439054	OUTGRG EXT FOLD SLIDE WLD, NTB
4	8	439058	FOLD SLIDE WEAR STRIP, 16R NTB
5	1	439060	OUTGRG EXT FOLD ARM WLD, NTB 03
6	1	439188	OUTER FOLD WELD, N40 05
7	1	439066	LIFT CYL PIN WLD, NTB STS 03
8	1	439068	ARTICULATOR CYL PIN WLD, NTB 03
9	2	439074	OUTGRG HINGE PIN WLD, NTB 03
10	1	439077	OUTGRG FOLD CYL MIT PIN, NTB 03
11	3	439078	ARTICULATOR FOLD CYL PIN, NTB
12	1	439113	HOSE RETAINER, NTB 03
13	17	470113	5/16UNC HEX FLANGE LOCK NUT
14	3	471005	GREASE ZERK, 1/4 28 X 1/2
15	2	475015	COTTER PIN 1/4 X 1 1/2, SS
16	2	618119	9/16MJIC-90-9/16MOR LBO
17	1	618732	9/16JIC .031 ORIFICE ADPTR
18	1	621568	HYD CYL, 2.00 X 18.00 X 1.125
19	1	621569	REPAIR KIT, HYD CYL 621568
20	2	618689	9/16MJ-90-9/16MOR .042 CHK VLV
21	1	621558	HYD CYL, 3.00 X 11.00 X 1.380
22	1	621559	REPAIR KIT, HYD CYL 621558
23	16	900060	5/16UNC X 1" FLT SOC CAP SCR
24	1	900065	5/16UNC X 1" HEX BOLT
25	2	900069	5/16UNC X 2" HEX BOLT
26	2	900134	3/8UNC X 2 1/2 SER FLANGE BOLT
27	2	900393	5/8UNC X 1" FLT SOC CAP SCR
28	2	900534	1" UNC X 3" HEX BOLT
29	12	910017	1-8 HEX NUT
30	2	914004	3/8UNC HEX STOVER NUT
31	4	914002	5/16UNC HEX STOVER NUT
32	6	920508	1" LOCK WASHER
33	1	439192	OUTER FOLD DROP WELD, N40 05
34	8	900334	5/8UNC X 1 3/4 HEX BOLT
35	8	914010	5/8UNC HEX STOVER NUT
36	2	900070	5/16UNC X 2 1/2 BOLT
37	1	439386	ARTICULATOR FLD CYL PIN, NTB'10
38	4	900536	1" UNC X 4" HEX BOLT, FULL THD

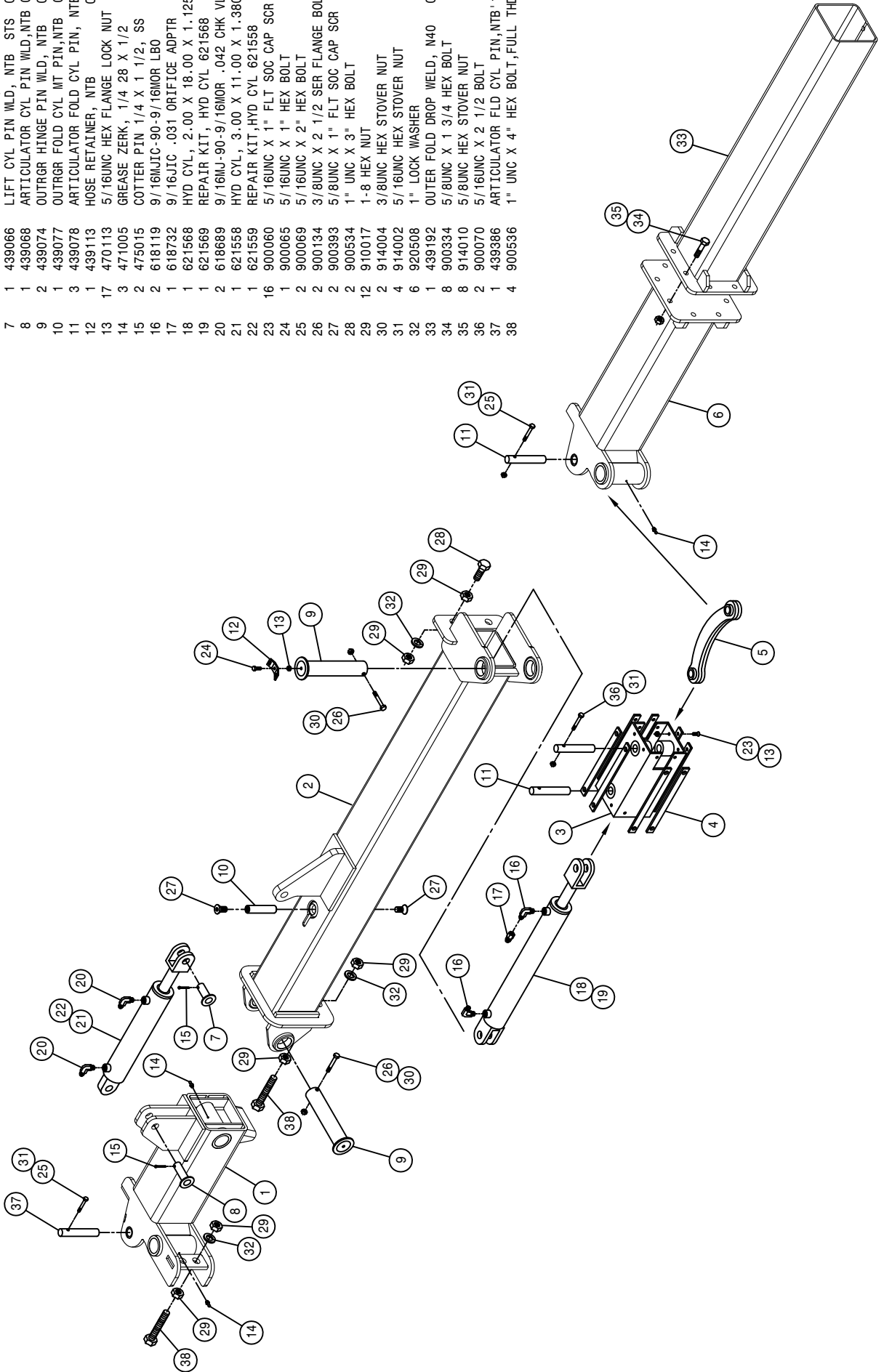

ROW UNIT ASSEMBLY

DET. QTY PART NO. DESCRIPTION

DET.	QTY	PART NO.	DESCRIPTION
1	1	439080	ROW DROP WLD, NTB STS 03
2	1	439092	HOSE RETAINER WLD, 1" NTB
3	1	439096	TIP MT BRKT WLD, NTB STS 03
4	2	473981	.750UNC-7.00ID-8.50 U-BOLT SQ
5	1	629727	FINISH PLUG FOR 1"SQ X 16 GA
6	4	914012	3/4UNC HEX STOVER NUT
7	1	439105	YETTER COULTER,20" GEN III
8	1	439106	20" SMOOTH BLADE, YETTER
9	1	439107	POLY GAUGE WHEEL, YETTER
10	1	439108	22" SHANK, YETTER
11	1	439109	4" SQ TUBE MT KIT, YETTER
12	1	439201	LOCKING COLLAR, YETTER 2975-303
13	1	439202	5/8-11 X 1" SQ HCPSS GR 5 ZP
14	2	439200	CLAMP CASTING, YETTER 2990-360
15	1	439203	SPRING BUSHING, YETTER 2555-096
16	1	439204	SPRING, 11", YETTER 2550-795
17	1	439205	10"POLY SPRING, YETTER 2550-771
18	1	439206	COULTER PIVOT, RH 2995-307
19	1	470045	COTTER PIN 1/4 X 1 3/4
20	1	439208	SPRING ROD, YETTER 2995-304
21	1	390984	COTTER PIN 1/8 X 1 1/4
22	1	439209	SPRING ROD PIN, YETTER 2995-308
23	1	439210	GENERATION III W/KNIFE ARM
24	1	439211	HUB ASSY, YETTER 2900-105
25	2	125028	BRG CUP LM67010
26	2	125010	BRG CONE LM67048
27	1	439212	HUB CAP, YETTER 2570-375
28	1	129010	SEAL C/R 16069
29	1	439213	INJECTOR MT PLT, YETTER 2995301
30	1	439214	SPRING INJ ASSY, YETTER 2995131
31	1	507028	SS PIPE NIPPLE .25NPT-3.00
32	1	439215	INJECTOR ROD, YETTER 2995-212
33	1	737817	NOZL MT CLMP, 1.00 SQ SS, Q-TJET
34	1	473937	ROLL PIN, 3/8DIA X 2 1/2
35	1	520070	HOSE CLAMP NO 8 STAINLESS
36	1	920013	1 1/2 SAE FLAT WASHER

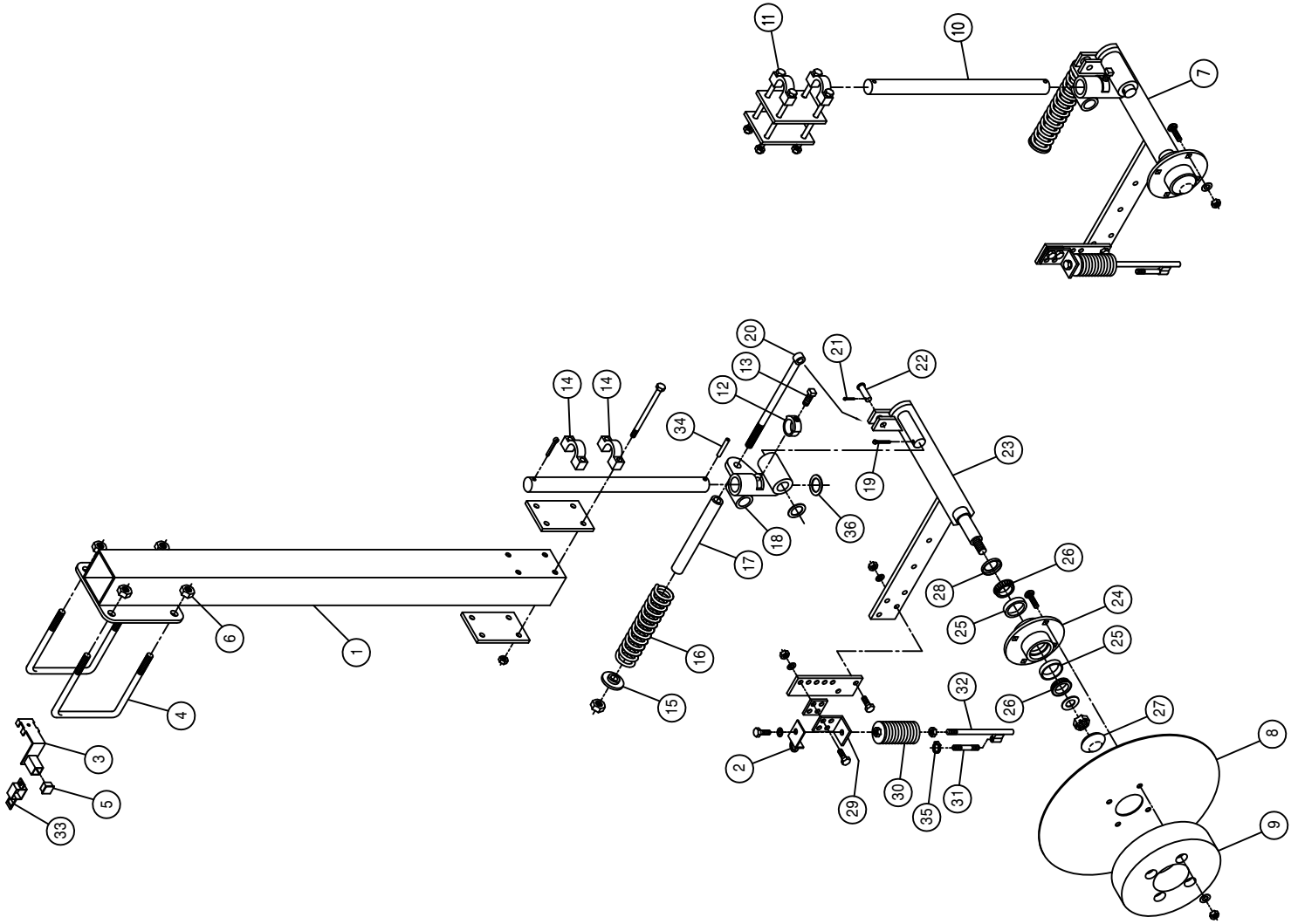

NOTE: USED WITH 24 ROW SKIP 20" 40' (LEFT SIDE)

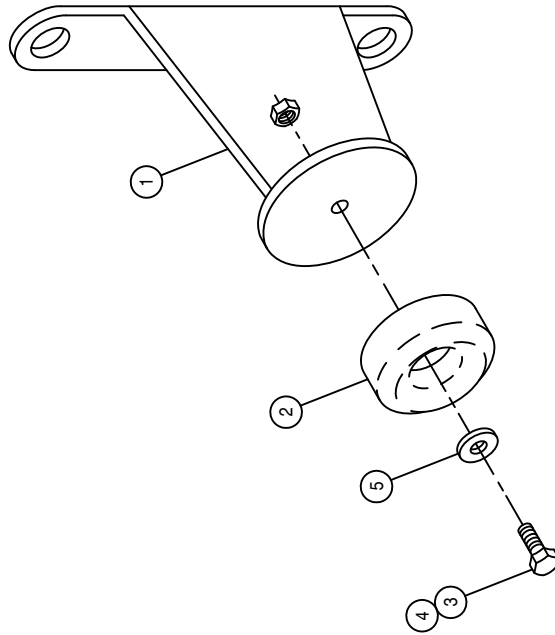
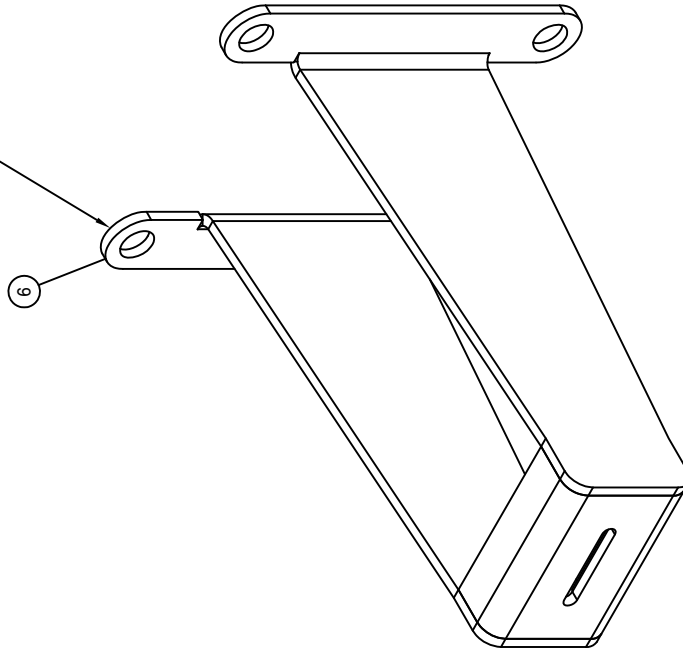

BUMPER ASSEMBLY

DET.	QTY	PART NO.	DESCRIPTION
1	1	439110	RUBBER BUMPER MT WLD, NTB 03
2	1	470098	RUBBER BUMPER 2.5000 X .38ID
3	1	900066	5/16UNC X 1 1/4 HEX BOLT
4	1	914002	5/16UNC HEX STOVER NUT
5	1	920001	5/16 SAE FLAT WASHER
6	1	439117	RUBBER BUMPER MT EXT WLD, NTB

FOAMER DROP AND HOSE ASSEMBLY

DET. QTY PART NO. DESCRIPTION

1	439100	RH FOAMER DROP CPLR WLD, NTB
2	439101	LH FOAMER DROP CPLR WLD, NTB
3	500067	1 NPT-90-3/4 HOSE BARB, POLY
4	520055	HOSE CLAMP NO 12 STAINLESS
5	520085	HOSE CLAMP NO 24 STAINLESS
6	601586	HOSE, 1 1/4 X 16 2BR BLK EPDM
7	696207	.75 HOSE BARB-FEMALE COUPLER
8	696208	.75 HOSE BARB-MALE COUPLER
9	714561	1.00NPT-1.25 HOSE BARB
10	195908	HOSE, 3/4ID-1/8W CLEAR VINYL X 252.00
11	195908	HOSE, 3/4ID-1/8W CLEAR VINYL X 348.00
12	195908	HOSE, 3/4ID-1/8W CLEAR VINYL X 192.00
13	195908	HOSE, 3/4ID-1/8W CLEAR VINYL X 288.00

NOTE: DETAILS 10 & 11 ARE USED WITH THE 40FT TOOLBAR.  
 DETAILS 12 & 13 ARE USED WITH THE 30FT TOOLBAR.

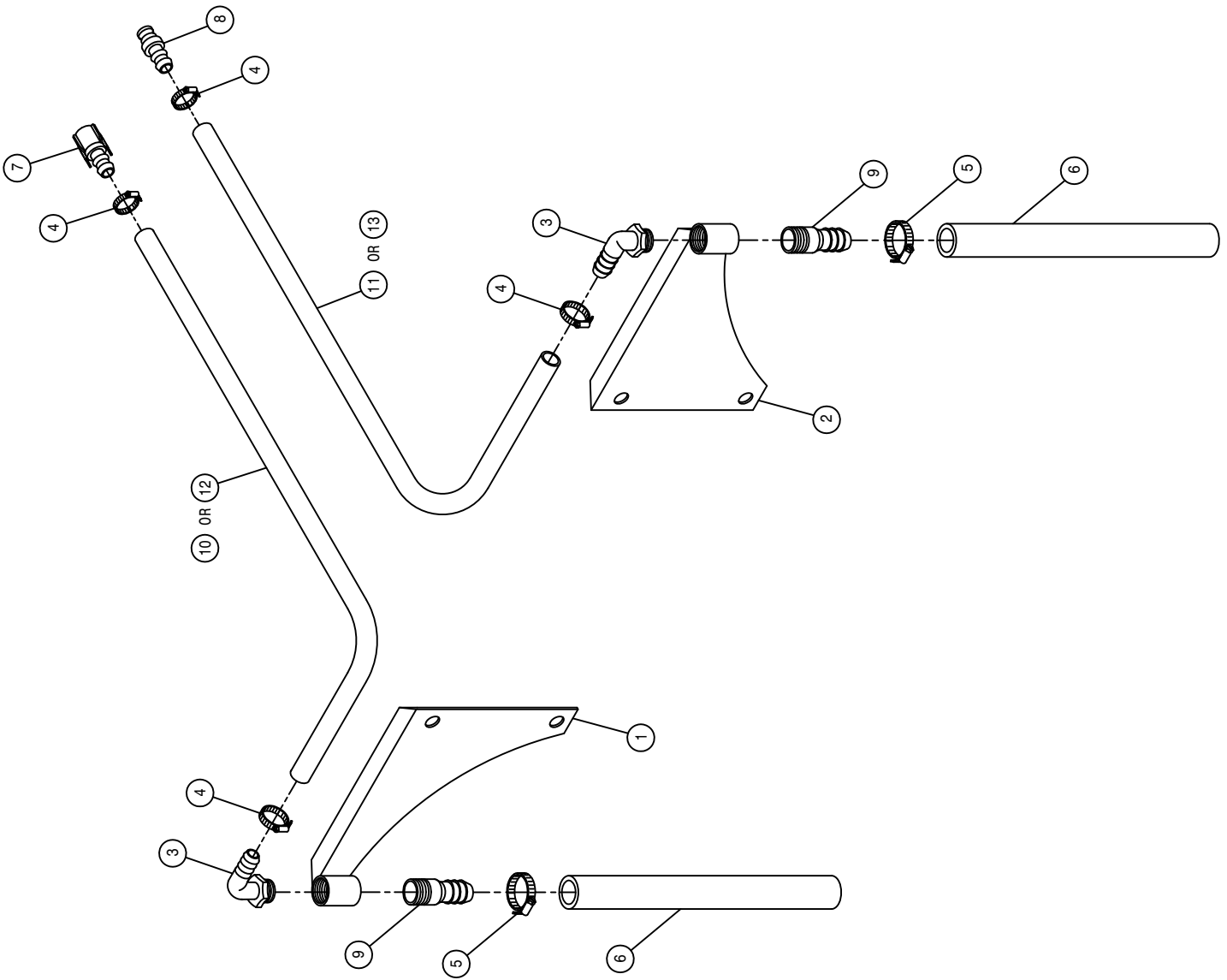

QUICK ATTACK ASSEMBLY

DET.	QTY	PART NO.	DESCRIPTION
1	1	439387	RECEPT QUICK ATTCH MT,NTB '10
2	2	900130	3/8UNC X 1 1/4 SER FLANGE BOLT
3	2	470087	3/8UNC HEX FLANGE LOCK NUT
4	1	618241	3/4MJIC-90-3/4MOR LBO
5	1	618183	3/4MJIC-90-7/8MOR LBO
6	1	618119	9/16MJIC-90-9/16MOR LBO
7	1	618804	HYD CPLR,MALE #14,9/16FOR
8	1	618807	HYD CPLR, FEM #12,3/4FOR
9	1	618806	HYD CPLR,MALE #12,7/8FOR
10	1	618255	DUST CAP/PLUG FOR 618804/805
11	1	618256	DUST CAP FOR 618806
12	1	618257	DUST PLUG FOR 618807

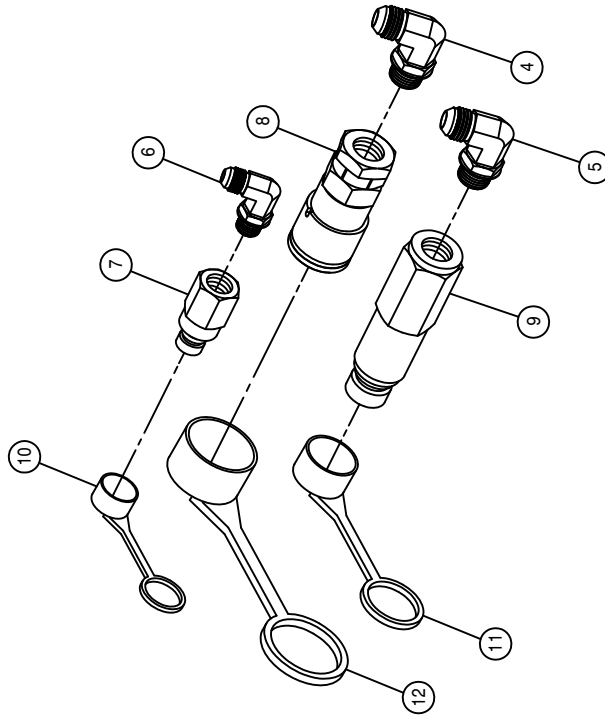
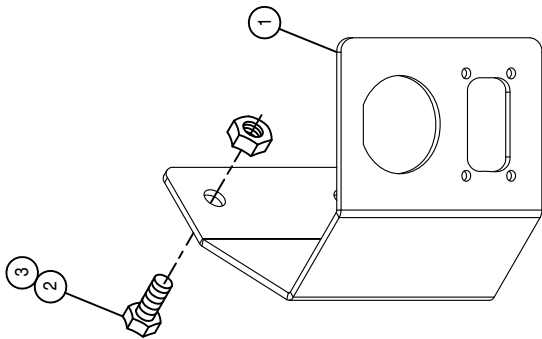

30FT TOOLBAR CONTROL VALVE ASSEMBLY

DET. QTY PART NO. DESCRIPTION

DET.	QTY	PART NO.	DESCRIPTION
1	1	606280	HYD VALVE, SAUER 6SPL NTB
2	7	618119	9/16MJIC-90-9/16MOR LBO
3	1	618241	3/4MJIC-90-3/4MOR LBO
4	1	618327	3/4MJIC-7/8MOR ADPTR
5	6	618440	9/16MJIC-90-9/16MOR EX LG LBO
6	2	618754	9/16MOR PLUG, HEX SOCKET
7	4	900128	3/8UNC X 3/4 HEX BOLT

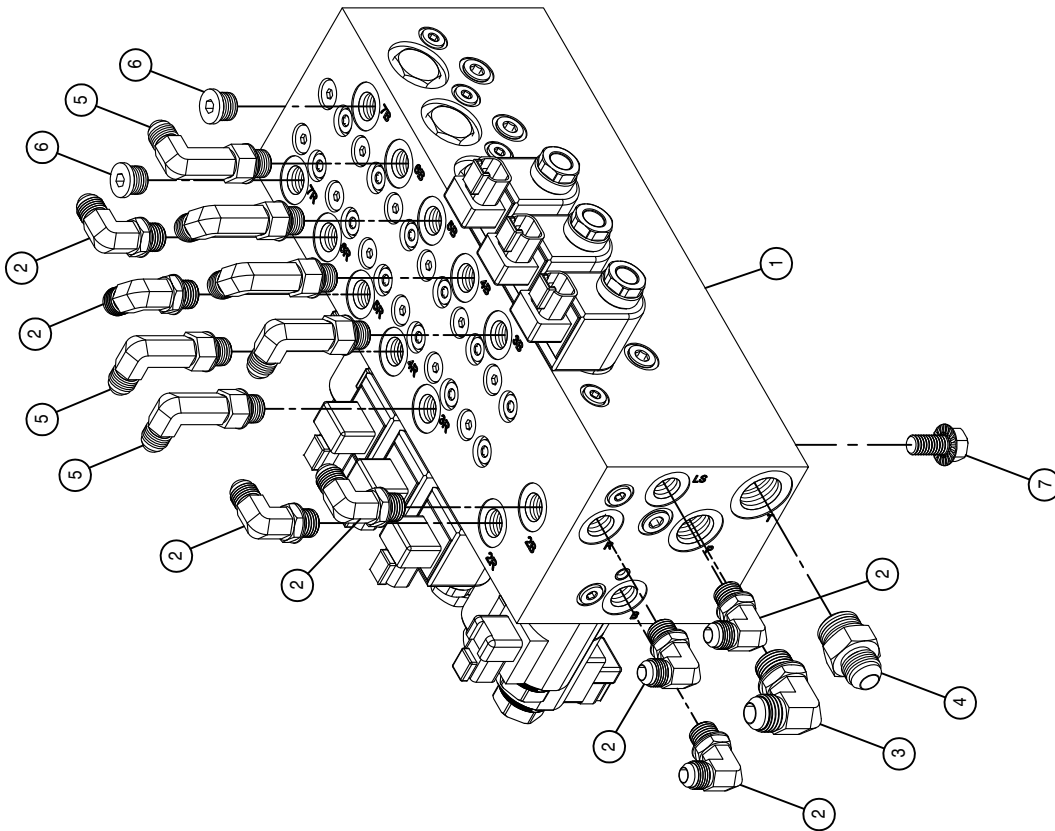



40FT TOOLBAR CONTROL VALVE ASSEMBLY

DET. QTY PART NO. DESCRIPTION

QTY	PART NO.	DESCRIPTION
1	606280	HYD VALVE, SAUER 6SPL NTB 07
2	618119	9/16MJIC-90-9/16MOR LBO
3	618241	3/4MJIC-90-3/4MOR LBO
4	618327	3/4MJIC-7/8MOR ADPTR
5	618440	9/16MJIC-90-9/16MOR EX LG LBO
6	618444	9/16MOR RUN TEE-9/16MJIC
7	618618	9/16MJIC-90-9/16FJIC SWIV LBO
8	900128	3/8UNC X 3/4 HEX BOLT

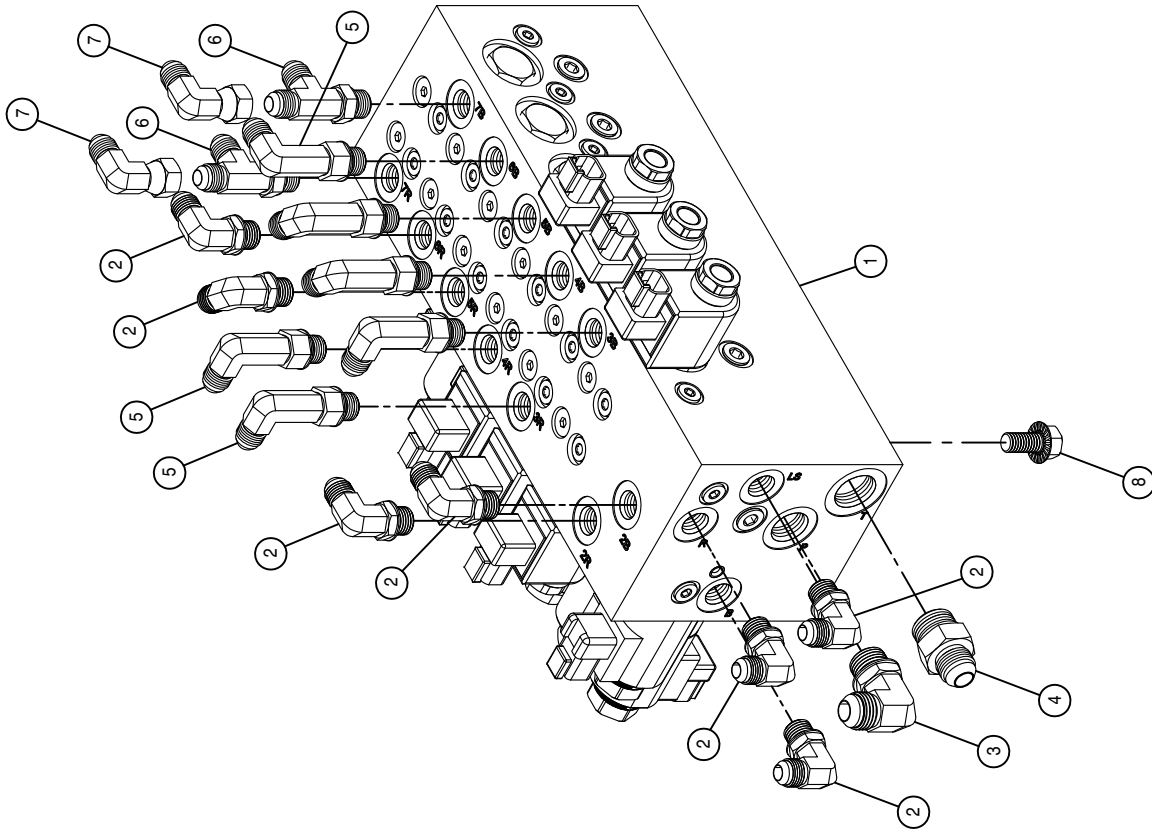

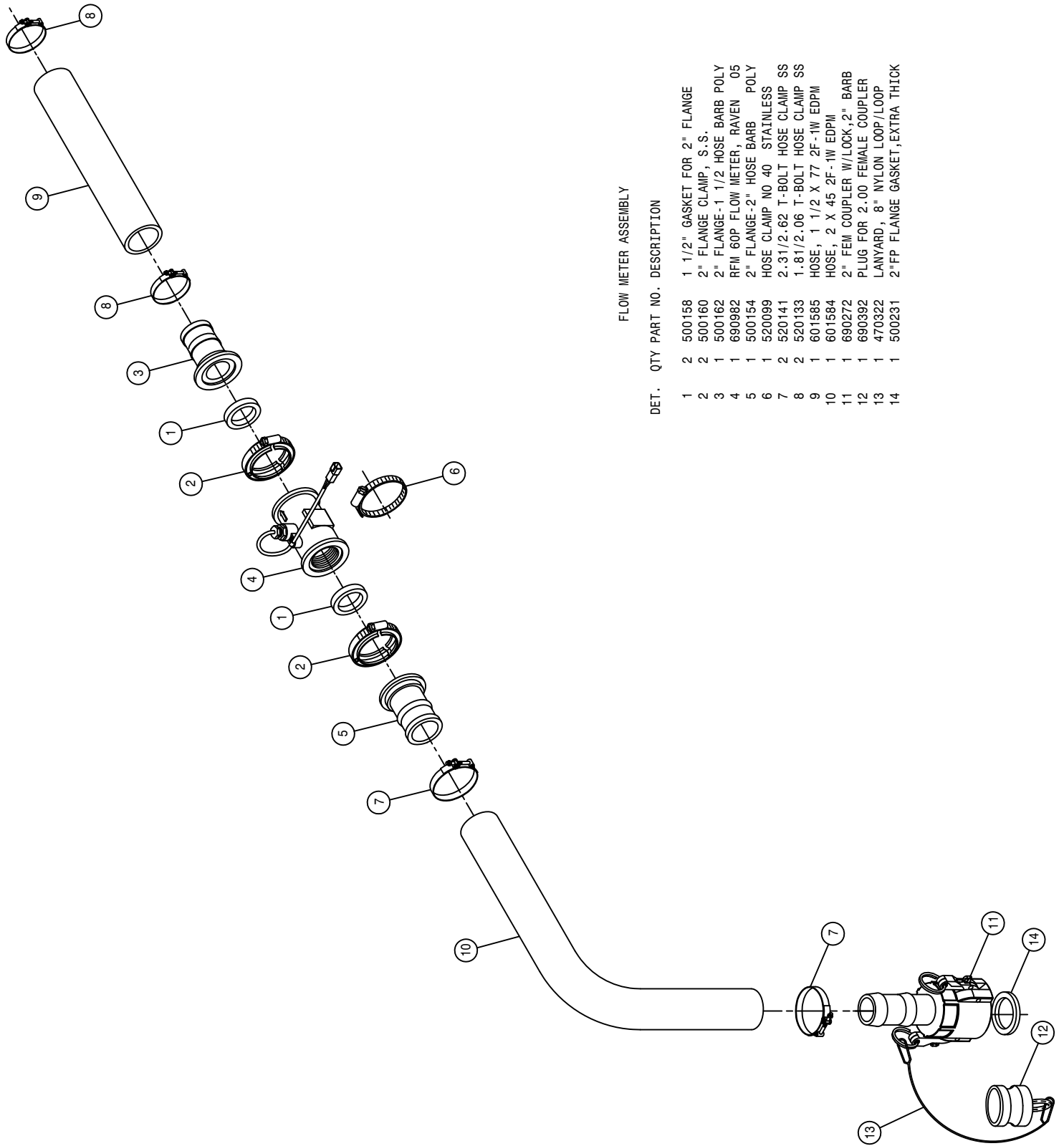

FLOW METER ASSEMBLY

DET.	QTY	PART NO.	DESCRIPTION
1	2	500158	1 1/2" GASKET FOR 2" FLANGE
2	2	500160	2" FLANGE CLAMP, S.S.
3	1	500162	2" FLANGE-1 1/2 HOSE BARB POLY
4	1	690982	RFM 60P FLOW METER, RAVEN 05
5	1	500154	2" FLANGE-2" HOSE BARB POLY
6	1	520099	HOSE CLAMP NO 40 STAINLESS
7	2	520141	2.31/2.62 T-BOLT HOSE CLAMP SS
8	2	520133	1.81/2.06 T-BOLT HOSE CLAMP SS
9	1	601585	HOSE, 1 1/2 X 77 2F-1W EDPM
10	1	601584	HOSE, 2 X 45 2F-1W EDPM
11	1	690272	2" FEM COUPLER W/LOCK, 2" BARB
12	1	690392	PLUG FOR 2.00 FEMALE COUPLER
13	1	470322	LANYARD, 8" NYLON LOOP/LOOP
14	1	500231	2"FP FLANGE GASKET, EXTRA THICK

SOLUTION CONTROL VALVE ASSEMBLY

DET. QTY PART NO. DESCRIPTION

DET.	QTY	PART NO.	DESCRIPTION
1	1	292016	IOAN-XA2 MODULE
2	12	470113	5/16UNC HEX FLANGE LOCK NUT
3	2	470118	1/4UNC X 3/4 FLANGE HEX BOLT
4	2	470121	1/4UNC HEX FLANGE LOCK NUT
5	2	472195	5/16UNC-2 11/16ID-3 9/16U-BOLT
6	3	500151	2" FLANGE TEE
7	7	500158	1 1/2" GASKET FOR 2" FLANGE
8	8	500160	2" FLANGE CLAMP, S.S.
9	1	500172	2" FLANGE-1" HOSE BARB POLY
10	2	500189	2" FLANGE-90-1" HOSE BARB POLY
11	2	500194	2"FP FLANGE CLAMP, S.S.
12	2	500195	2"FP FLANGE GASKET EPDM
13	2	500199	2"FP FLANGE-2"FLANGE REDU POLY
14	1	500229	2"FP FLANGE PLUG, 1/4FNPT POLY
15	1	500230	2" FP FLANGE-1 1/2" HOSE BARB
16	1	690359	PRESSURE GA GLYCERI 100 PSI
17	1	696254	O-RING, KZCO FLANGED VALVES
18	1	696256	VALVE, KZCO C2F-60B-M-S9
19	1	439194	ELECT CTRL MT PANEL, NTB 05
20	1	439195	ELECT CTRL BOX COVER, NTB 05
21	8	470233	5/16UNC X 3/4 FLANGE HEX BOLT

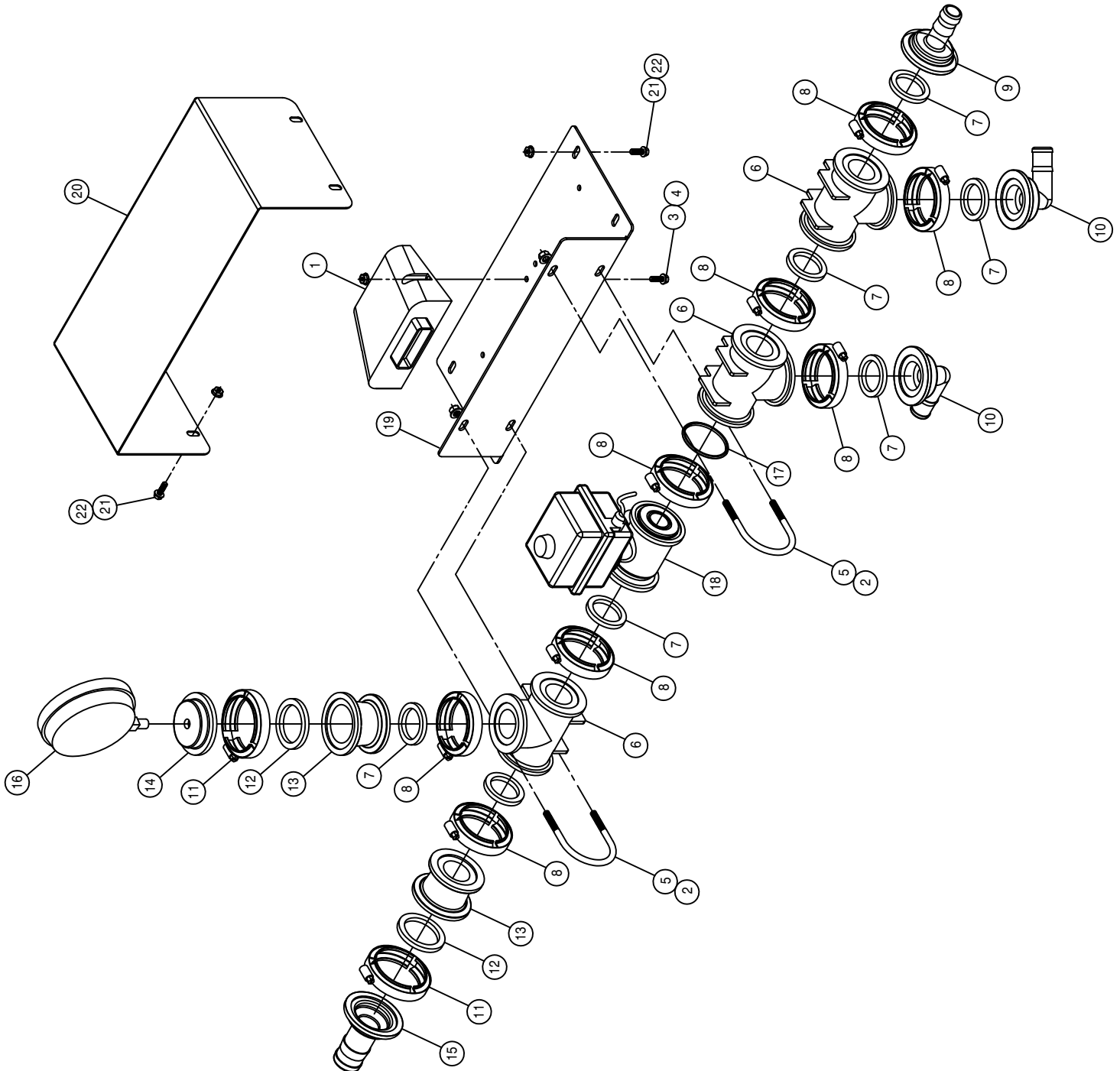

HOSE DIAG, 12R 30" 30FT NTB

DET. QTY PART NO. DESCRIPTION

1	1	601491	HOSE, 1 X 30 1BR BLK EPDM
2	1	601495	HOSE, 1 X 110 1BR BLK EPDM
3	11	601581	HOSE, 1/2 X 86 1BR BLK EPDM
4	6	601582	HOSE, 3/4 X 14 1BR BLK EPDM
5	5	601583	HOSE, 3/4 X 28 1BR BLK EPDM
6	1	601584	HOSE, 2 X 45 2F-1W EPDM
7	1	601585	HOSE, 1 1/2 X 77 2F-1W EPDM
8	1	690272	2" FEM COUPLER W/LOCK, 2" BARB
9	11	737790	CAP SET, ROUND, RED QUICK TEEJET
10	11	737791	1/2" TEEJET HOSE SHANK, NYLON
11	6	737829	QUICK TJET LBO, 1-TIP BODY .75
12	5	737830	QUICK TJET TEE, 1-TIP BODY .75
13	3	500121	3/4 HOSE BARB-1" BRNCH TEE, POLY
14	22	520055	HOSE CLAMP NO 12 STAINLESS
15	11	520070	HOSE CLAMP NO 8 STAINLESS
16	6	520087	HOSE CLAMP NO 20 STAINLESS
17	1	601496	HOSE, 1 X 120 1BR BLK EPDM

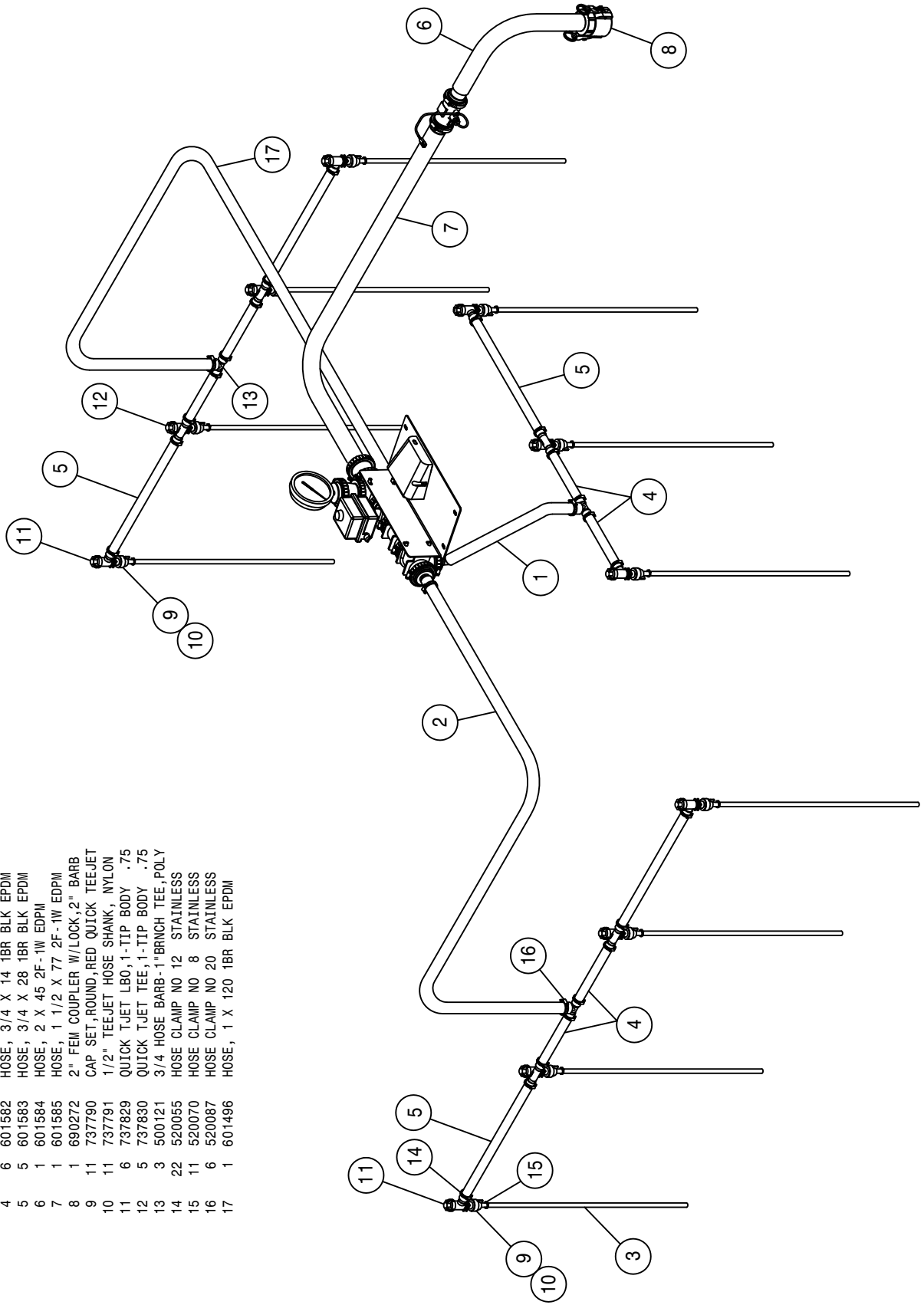

HOSE DIAG, 16R 30" 40FT NTB

DET. QTY PART NO. DESCRIPTION

1	1	601496	HOSE, 1 X 120 1BR BLK EPDM
2	4	601174	HOSE, 3/4 X 60 1BR BLK EPDM
3	1	601491	HOSE, 1 X 30 1BR BLK EPDM
4	1	601495	HOSE, 1 X 110 1BR BLK EPDM
5	15	601581	HOSE, 1/2 X 86 1BR BLK EPDM
6	10	601582	HOSE, 3/4 X 14 1BR BLK EPDM
7	3	601583	HOSE, 3/4 X 28 1BR BLK EPDM
8	1	601584	HOSE, 2 X 45 2F-1W EDPM
9	1	601585	HOSE, 1 1/2 X 77 2F-1W EDPM
10	2	500073	3/4 HOSE BARB TEE, POLY
11	3	500121	1"BRNCH-3/4 HOSE BARB TEE,POLY
12	15	737790	CAP SET,ROUND,RED QUICK TEEJET
13	15	737791	1/2" TEEJET HOSE SHANK, NYLON
14	8	737829	QUICK TJET LBO,1-TIP BODY .75
15	7	737830	QUICK TJET TEE,1-TIP BODY .75
16	1	690272	2" FEM COUPLER W/LOCK,2" BARB
17	34	520055	HOSE CLAMP NO 12 STAINLESS
18	15	520070	HOSE CLAMP NO 8 STAINLESS
19	6	520087	HOSE CLAMP NO 20 STAINLESS

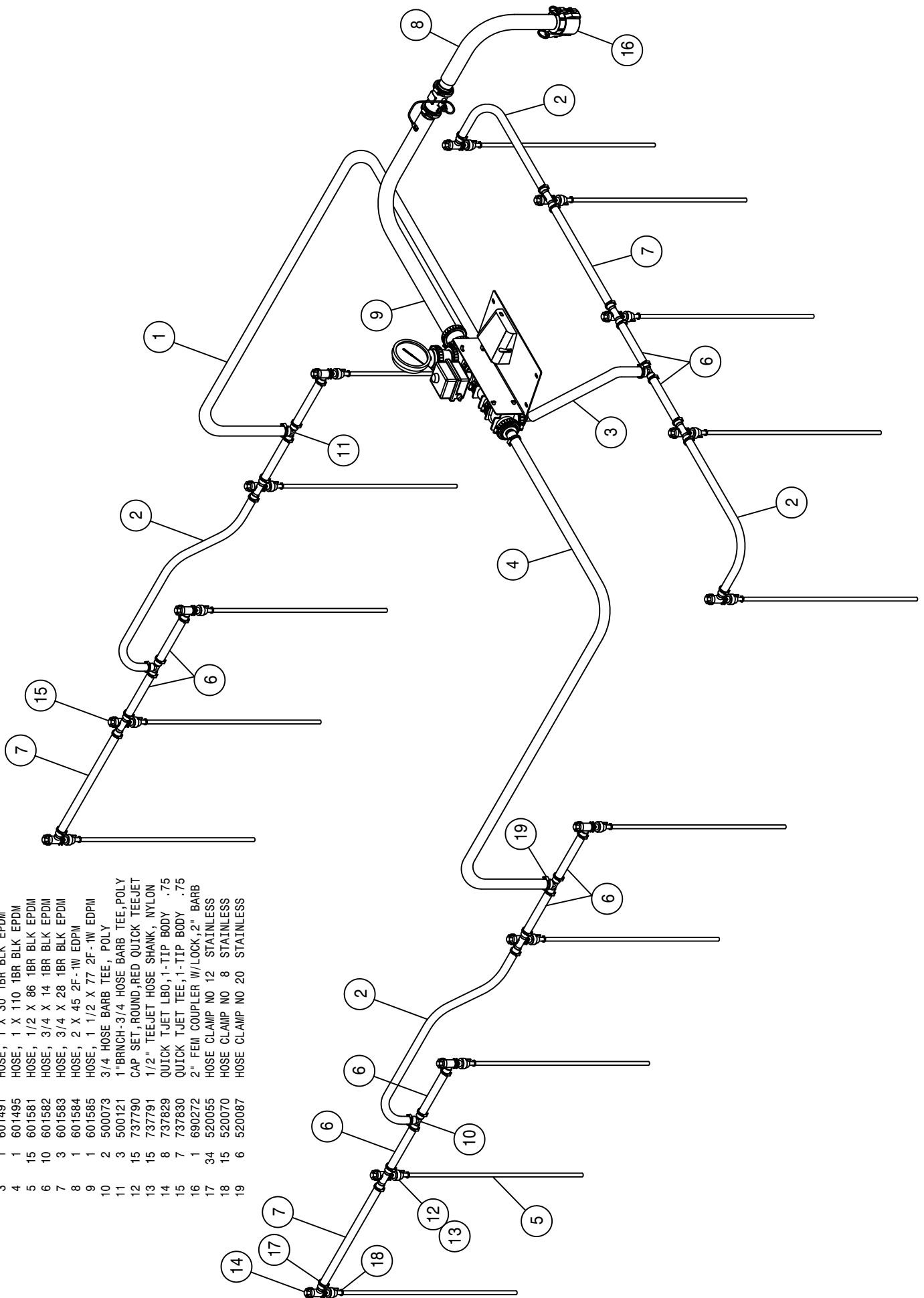

HOSE DIAG. 1BR SKIP 20" - 30"

DET. QTY PART NO. DESCRIPTION

1	1	601491	HOSE, 1 X 30 1BR BLK EPDM
2	1	601495	HOSE, 1 X 110 1BR BLK EPDM
3	9	601581	HOSE, 1/2 X 86 1BR BLK EPDM
4	1	601584	HOSE, 2 X 45 2F-1W EPDM
5	1	601585	HOSE, 1 1/2 X 77 2F-1W EPDM
6	1	601603	HOSE, 3/4 X 19 1BR BLK EPDM
7	3	601605	HOSE, 3/4 X 38 1BR BLK EPDM
8	1	690272	2" FEM COUPLER W/LOCK, 2" BARB
9	737790	CAP SET, ROUND, RED QUICK TEEJET	
10	9	737791	1/2" TEEJET HOSE SHANK, NYLON
11	6	737829	QUICK TJET LBO, 1-TIP BODY .75
12	3	737830	QUICK TJET TEE, 1-TIP BODY .75
13	3	500121	3/4 HOSE BARB, 1" BRNCH TEE, POLY
14	18	520055	HOSE CLAMP NO 12 STAINLESS
15	9	520070	HOSE CLAMP NO 8 STAINLESS
16	6	520087	HOSE CLAMP NO 20 STAINLESS
17	1	601496	HOSE, 1 X 120 1BR BLK EPDM

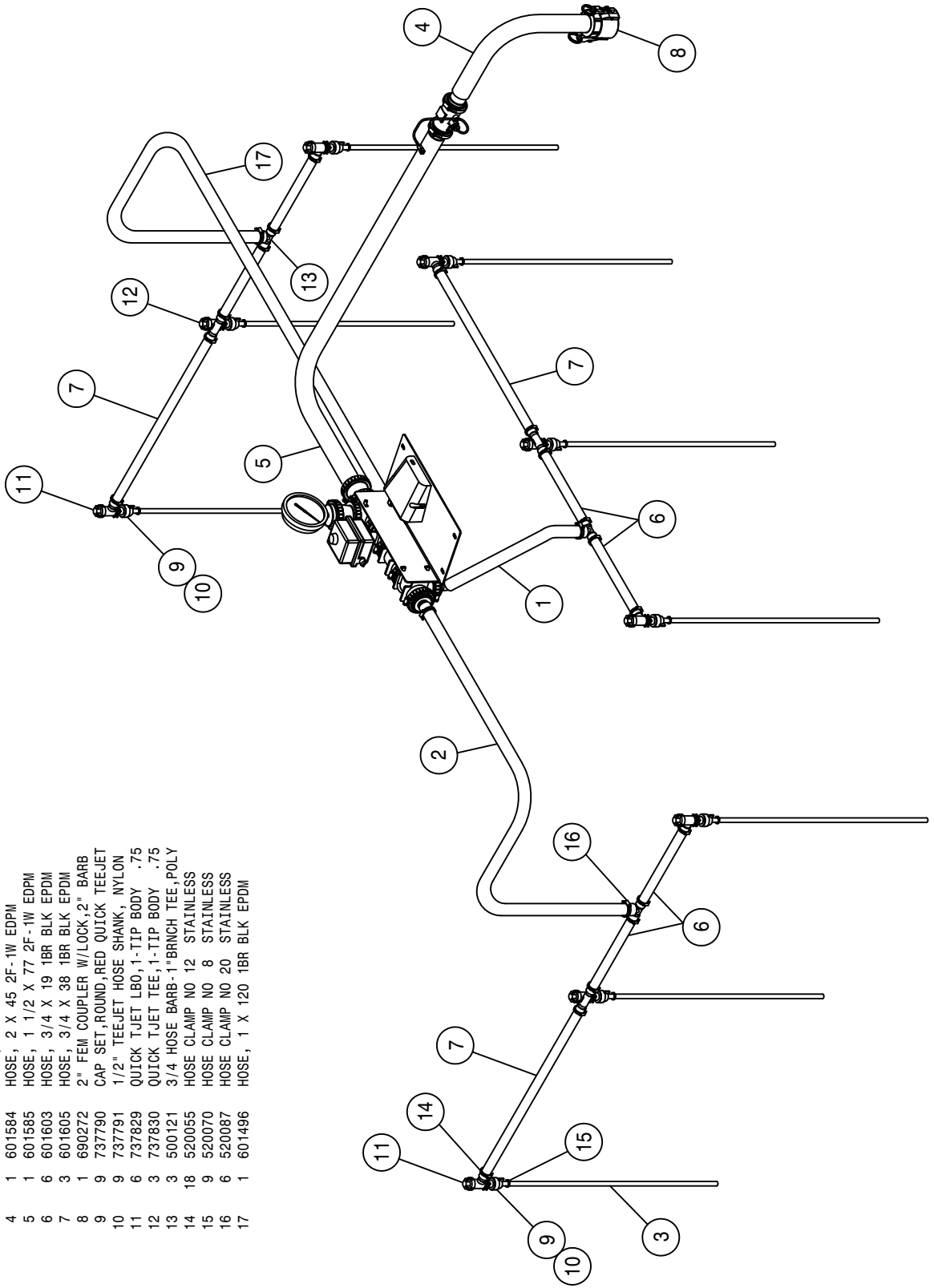

HOSE DIAG, 24R 20" 40FT NTB

DET.	QTY	PART NO.	DESCRIPTION
1	1	601491	HOSE, 1 X 30 1BR BLK EPDM
2	1	601495	HOSE, 1 X 110 1BR BLK EPDM
3	11	601581	HOSE, 1/2 X 86 1BR BLK EPDM
4	1	601584	HOSE, 2 X 45 2F-1W EDPM
5	1	601585	HOSE, 1 1/2 X 77 2F-1W EDPM
6	6	601603	HOSE, 3/4 X 19 1BR BLK EPDM
7	5	601605	HOSE, 3/4 X 38 1BR BLK EPDM
8	1	690272	2" FEM COUPLER W/LOCK, 2" BARB
9	11	737790	CAP SET, ROUND, RED QUICK TEEJET
10	11	737791	1/2" TEEJET HOSE SHANK, NYLON
11	6	737829	QUICK TJET LBO, 1-TIP BODY .75
12	5	737830	QUICK TJET TEE, 1-TIP BODY .75
13	3	500121	3/4 HOSE BARB-1" BRNCH TEE, POLY
14	22	520055	HOSE CLAMP NO 12 STAINLESS
15	11	520070	HOSE CLAMP NO 8 STAINLESS
16	6	520087	HOSE CLAMP NO 20 STAINLESS
17	1	601496	HOSE, 1 X 120 1BR BLK EPDM

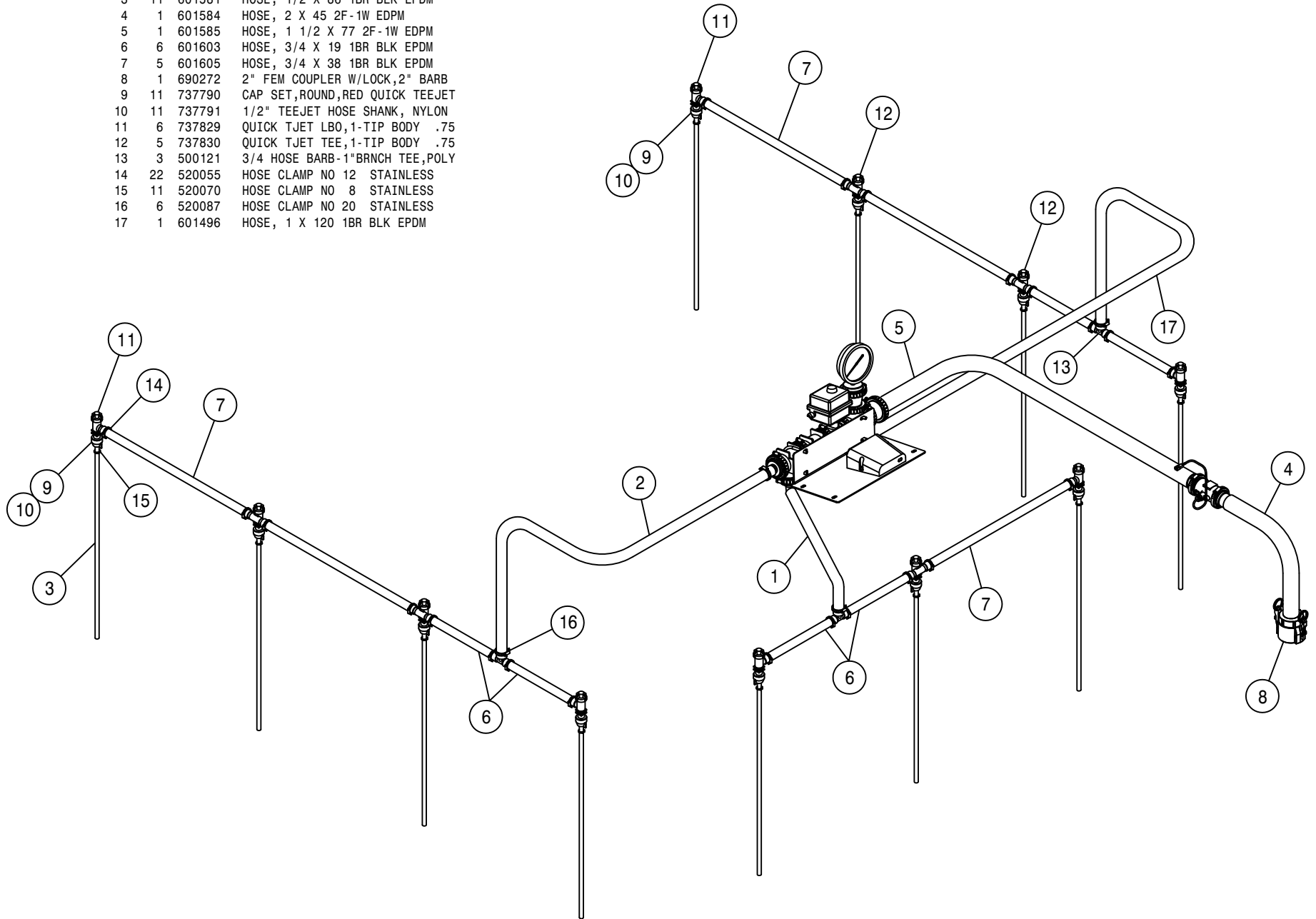

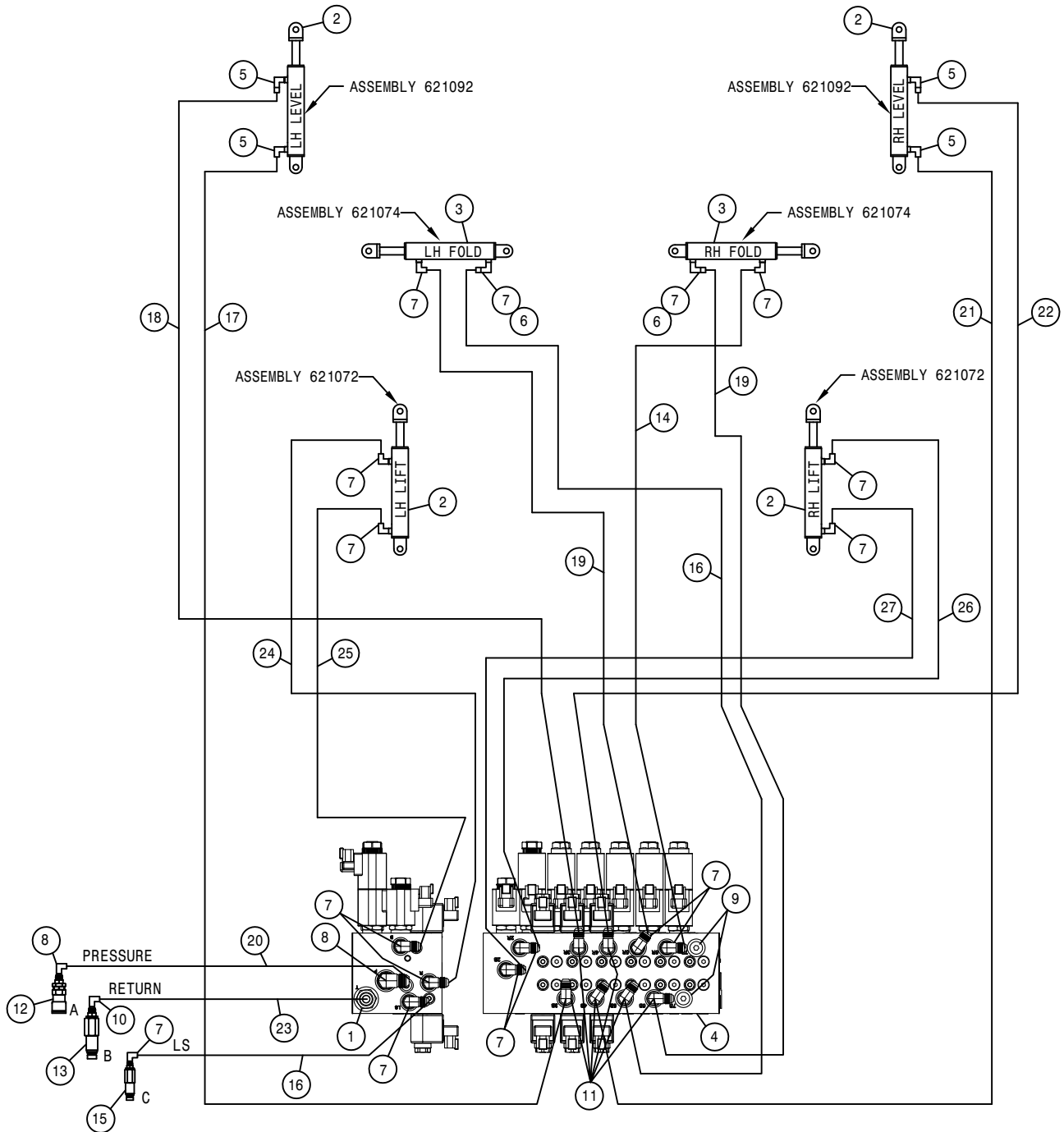



NITROGEN T-BAR 30FT HYD SCHEMATIC 2007  
REFERENCE DRAWING NO. 498958

DET.	QTY	PART NO.	DESCRIPTION	DET.	QTY	PART NO.	DESCRIPTION
1	1	618327	3/4MJIC-7/8MOR ADPTR	15	1	618804	HYD CPLR,MALE #14,9/16FOR
2	4	621558	LEVEL CYL, 3.00 X 11.00 STS	16	2	616209	04-451TC-06FJX-06FJX-64 H/A
3	2	621566	OUTRGR FOLD CYL, 2.50 X 11.00	17	1	616084	04-451TC-06FJX-06FJX-46 H/A
4	1	606280	HYD VALVE,SAUER 6SPL NTB 07	18	1	616176	04-451TC-06FJX-06FJX-58 H/A
5	4	618689	9/16MJ-90-9/16MOR .042 CHK VLV	19	2	616177	04-451TC-06FJX-06FJX-74 H/A
6	2	618732	9/16JIC .031 ORIFICE ADPTR	20	1	616234	08-451TC-08FJX-08FJX-66 H/A
7	16	618119	9/16MJIC-90-9/16MOR LBO	21	1	616561	04-451TC-06FJX-06FJX-132 H/A
8	2	618241	3/4MJIC-90-3/4MOR LBO	22	1	616180	04-451TC-06FJX-06FJX-143 H/A
9	2	618754	9/16MOR PLUG, HEX SOCKET	23	1	616562	08-451TC-08FJX-08FJX90-66 H/A
10	1	618183	3/4MJIC-90-7/8MOR LBO	24	1	616182	06-451TC-06FJX-06FJX-41 H/A
11	6	618440	9/16MJIC-90-9/16MOR EX LG LBO	25	1	616183	06-451TC-06FJX-06FJX-52 H/A
12	1	618807	HYD CPLR, FEM #12,3/4FOR	26	1	616563	06-451TC-06FJX-06FJX-141 H/A
13	1	618806	HYD CPLR,MALE #12,7/8FOR	27	1	616564	06-451TC-06FJX-06FJX-151 H/A
14	1	616560	04-451TC-06FJX-06FJX-87 H/A				

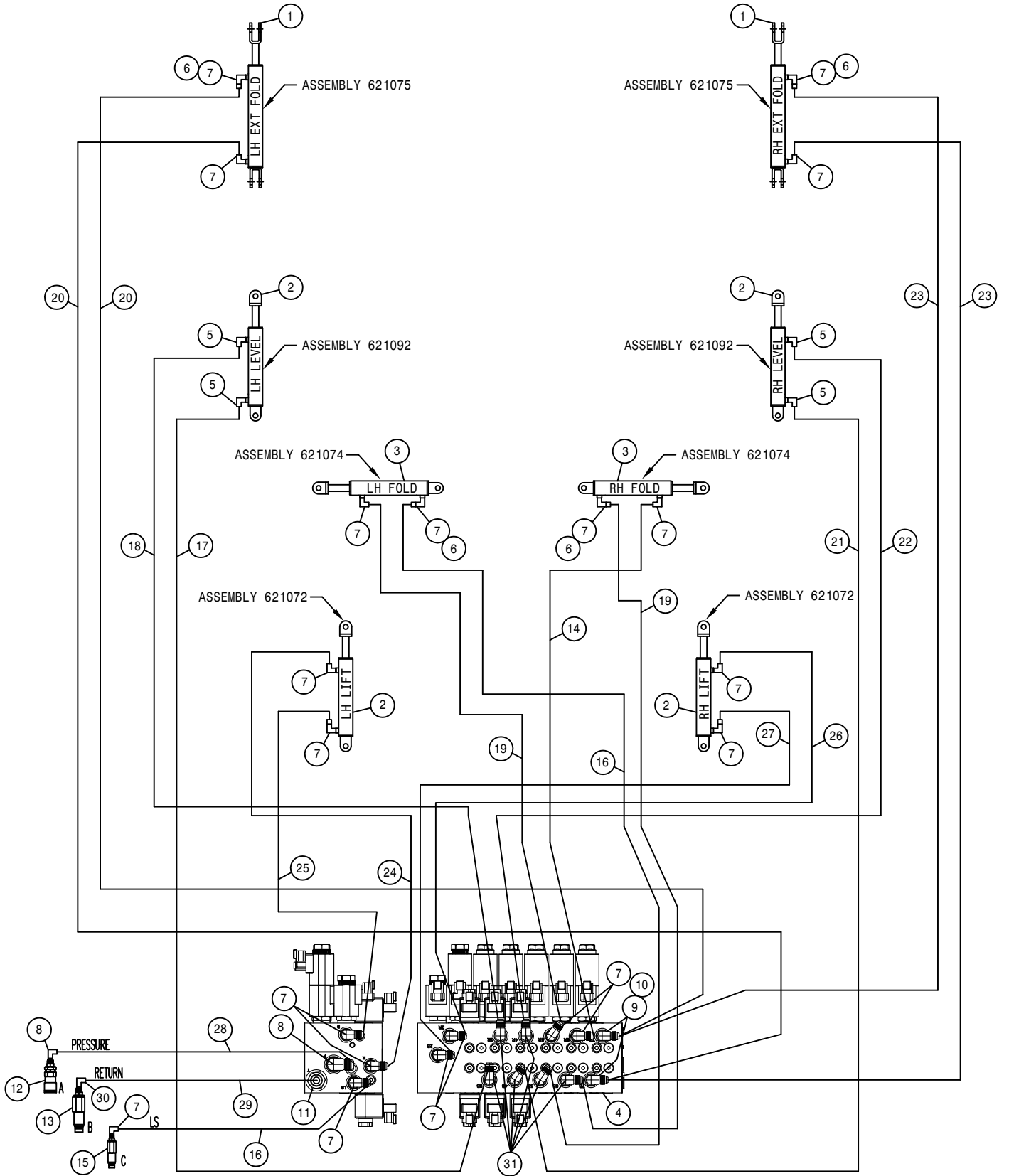

NITROGEN T-BAR 40FT HYDRAULIC SCHEMATIC 2007  
REFERENCE DRAWING NO. 498959

DET.	QTY	PART NO.	DESCRIPTION	DET.	QTY	PART NO.	DESCRIPTION	
1	2	621568	OUTRGR FOLD CYL, 2.00 X 18	17	1	616084	04-451TC-06FJX-06FJX-46	H/A
2	4	621558	LEVEL CYL, 3.00 X 11.00 STS	18	1	616176	04-451TC-06FJX-06FJX-58	H/A
3	2	621566	OUTRGR FOLD CYL, 2.50 X 11.00	19	2	616177	04-451TC-06FJX-06FJX-74	H/A
4	1	606280	HYD VALVE, SAUER 6SPL NTB 07	20	2	616178	04-451TC-06FJX-06FJX-94	H/A
5	4	618689	9/16MJ-90-9/16MOR .042 CHK VLV	21	1	616561	04-451TC-06FJX-06FJX-132	H/A
6	4	618732	9/16JIC .031 ORIFICE ADPTR	22	1	616180	04-451TC-06FJX-06FJX-143	H/A
7	20	618119	9/16MJIC-90-9/16MOR LBO	23	2	616181	04-451TC-06FJX-06FJX-168	H/A
8	2	618241	3/4MJIC-90-3/4MOR LBO	24	1	616182	06-451TC-06FJX-06FJX-41	H/A
9	2	618444	9/16MOR RUN TEE-9/16MJIC	25	1	616183	06-451TC-06FJX-06FJX-52	H/A
10	2	618618	9/16MJIC-90-9/16FJIC SWIV LBO	26	1	616563	06-451TC-06FJX-06FJX-141	H/A
11	1	618327	3/4MJIC-7/8MOR ADPTR	27	1	616564	06-451TC-06FJX-06FJX-151	H/A
12	1	618807	HYD CPLR, FEM #12, 3/4FOR	28	1	616234	08-451TC-08FJX-08FJX-66	H/A
13	1	618806	HYD CPLR, MALE #12, 7/8FOR	29	1	616562	08-451TC-08FJX-08FJX90-66	H/A
14	1	616560	04-451TC-06FJX-06FJX-87	H/A	30	1	618183	3/4MJIC-90-7/8MOR LBO
15	1	618804	HYD CPLR, MALE #14, 9/16FOR	31	6	618440	9/16MJIC-90-9/16MOR EX LG LBO	
16	2	616209	04-451TC-06FJX-06FJX-64	H/A				

CONTROL VALVE  
BOTTOM VIEW

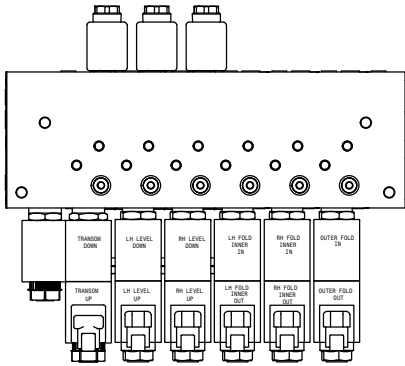

CONTROL VALVE  
SIDE VIEW

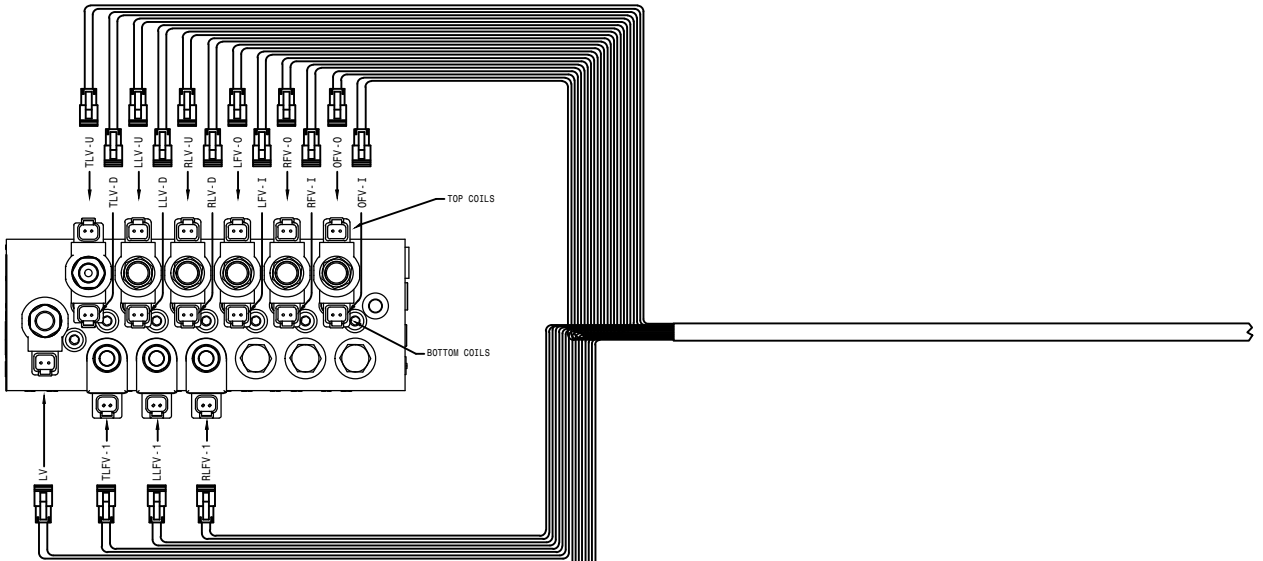

CONTROL VALVE  
TOP VIEW

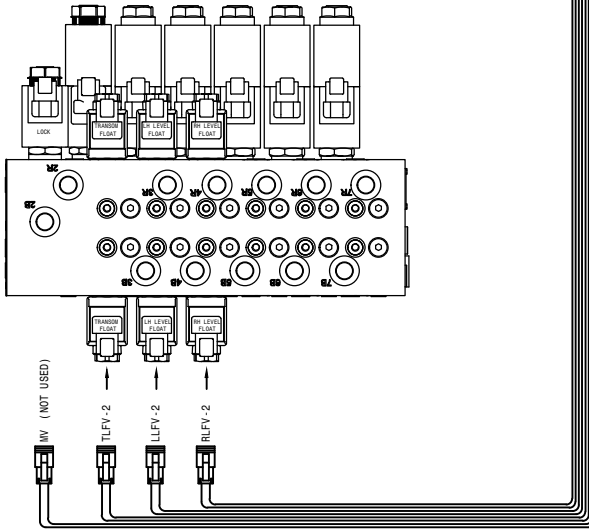

CAB TO BOOM HARNESS } 293917 - CAB TO BOOM HARNESS, STS 10

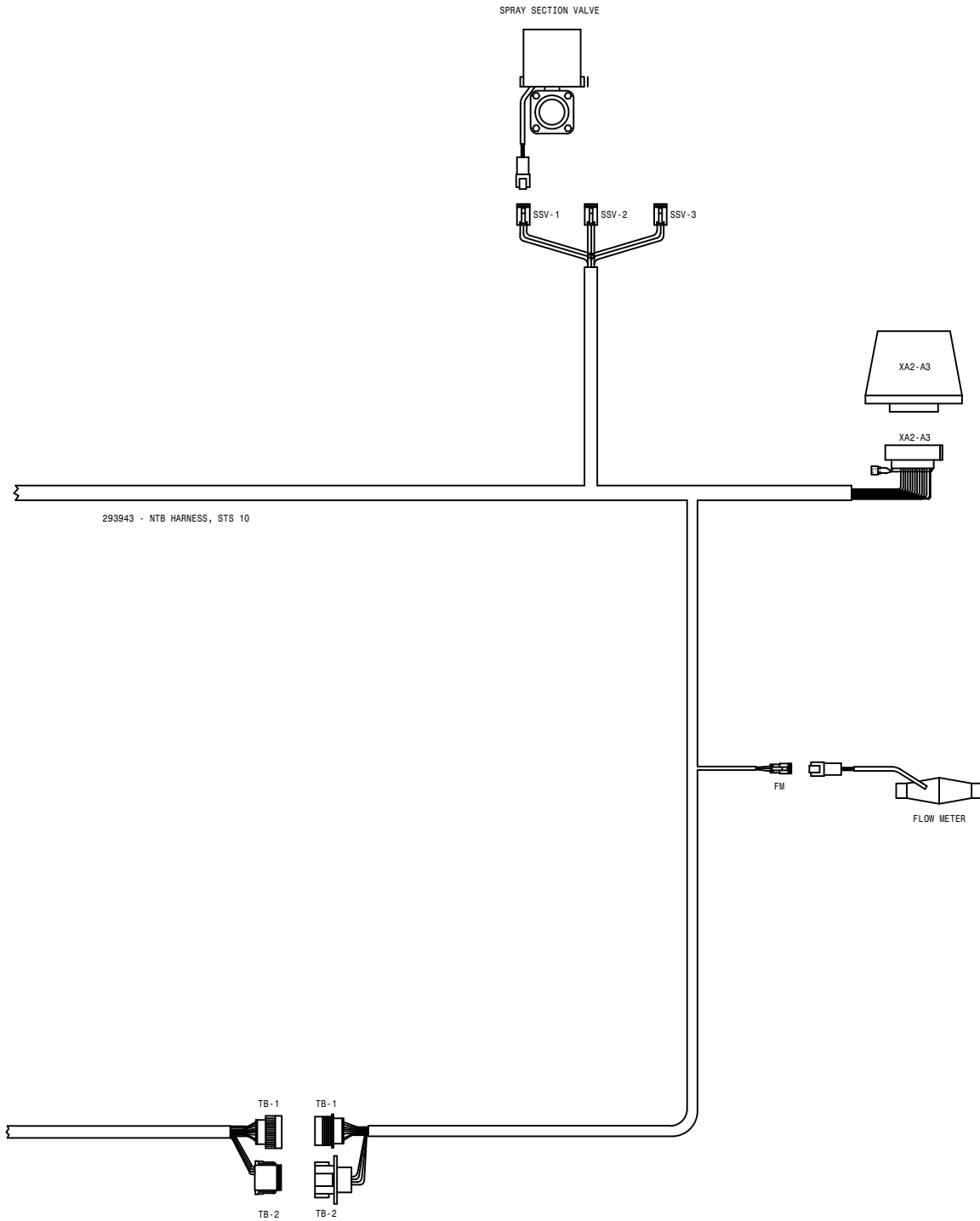

06-11-09 TLM
STS NTB WIRING DIAGRAM 10
REVISION DATE: 07-17-14
499045

# Notes:



# PARTS ORDER FAX

**Fax**  
**24 hours**  
**a day**  
**7 days**  
**a week\***

Ph. 1 (800) 247-4885

Fx. 1 (515) 532-3553

Photocopy and fax to Hagie Customer Support Department

**ORDERED BY/BILL TO:**

Name \_\_\_\_\_  
 Co. Name \_\_\_\_\_  
 Street \_\_\_\_\_  
 City, St, Zip \_\_\_\_\_  
 Ph. \_\_\_\_\_ Fx. \_\_\_\_\_

**SHIP TO:**

Name \_\_\_\_\_  
 Co. Name \_\_\_\_\_  
 Street \_\_\_\_\_  
 City, St, Zip \_\_\_\_\_  
 Ph. \_\_\_\_\_ Fx. \_\_\_\_\_

HOW SHIP:  UPS Ground  Next Day  2 Day  3 Day  Other \_\_\_\_\_

If "HOW SHIP" is left blank, parts will be sent UPS ground service. If part is over 150 pounds, an independent motor freight company will be used.

**PAYMENT:**  Hagie Account #\*\* \_\_\_\_\_  
 C.O.D

American Express  Discover  Visa  Master Card

Signature: \_\_\_\_\_  
 name as appears on card: \_\_\_\_\_  
 card no. \_\_\_\_\_ exp. date \_\_\_\_\_

Year and Model No. \_\_\_\_\_

Serial No. \_\_\_\_\_

Item Serial No. (if necessary):

Engine (include type) \_\_\_\_\_

Hydrostatic Pump (s) \_\_\_\_\_

Torque Hub \_\_\_\_\_  LF  RF  LR  RR

Wheel Motor \_\_\_\_\_  LF  RF  LR  RR

HAGIE Part No.	Qty.	Description

Check here if you want phone confirmation of parts order.

\* Orders received before 3:00 p.m., CST will be processed the same business day.  
 Regular business hours are Monday through Friday, 7:00 a.m. through 5:00 p.m..

\*\* If you do not have a Hagie account number, contact the Hagie Customer Support Department and you will be issued one.



# PARTS ORDER FAX

**Fax**  
**24 hours**  
**a day**  
**7 days**  
**a week\***

Ph. 1 (800) 247-4885

Fx. 1 (515) 532-3553

Photocopy and fax to Hagie Customer Support Department

**ORDERED BY/BILL TO:**

Name \_\_\_\_\_  
 Co. Name \_\_\_\_\_  
 Street \_\_\_\_\_  
 City, St, Zip \_\_\_\_\_  
 Ph. \_\_\_\_\_ Fx. \_\_\_\_\_

**SHIP TO:**

Name \_\_\_\_\_  
 Co. Name \_\_\_\_\_  
 Street \_\_\_\_\_  
 City, St, Zip \_\_\_\_\_  
 Ph. \_\_\_\_\_ Fx. \_\_\_\_\_

HOW SHIP:  UPS Ground  Next Day  2 Day  3 Day  Other \_\_\_\_\_

If "HOW SHIP" is left blank, parts will be sent UPS ground service. If part is over 150 pounds, an independent motor freight company will be used.

**PAYMENT:**  Hagie Account #\*\* \_\_\_\_\_  
 C.O.D

American Express  Discover  Visa  Master Card

Signature: \_\_\_\_\_  
 name as appears on card: \_\_\_\_\_  
 card no. \_\_\_\_\_ exp. date \_\_\_\_\_

Year and Model No. \_\_\_\_\_

Serial No. \_\_\_\_\_

Item Serial No. (if necessary):

Engine (include type) \_\_\_\_\_

Hydrostatic Pump (s) \_\_\_\_\_

Torque Hub \_\_\_\_\_  LF  RF  LR  RR

Wheel Motor \_\_\_\_\_  LF  RF  LR  RR

HAGIE Part No.	Qty.	Description

Check here if you want phone confirmation of parts order.

\* Orders received before 3:00 p.m., CST will be processed the same business day.  
 Regular business hours are Monday through Friday, 7:00 a.m. through 5:00 p.m..

\*\* If you do not have a Hagie account number, contact the Hagie Customer Support Department and you will be issued one.