



**PARTS MANUAL  
FOR  
HAGIE MODEL DTS 8T HI-TRACTOR**

**HAGIE MANUFACTURING COMPANY**

721 CENTRAL AVENUE WEST  
BOX 273  
CLARION, IOWA 50525-0273

(515) 532-2861

COVERS MACHINE SERIAL NUMBERS: U1220880001 thru U1220880100

08-07 493406  
02-08

SPRAYER IDENTIFICATION

Each Hagie sprayer is identified by means of a frame serial number. This serial number denotes the model, the year in which it was built, and the number of the sprayer. As for further identification, the engine has a serial number and the planetary hubs have identification plates that describe the type of mount and gear ratio. To insure prompt, efficient service when ordering parts or requesting service repairs from Hagie Manufacturing Company, record the serial and identification numbers in the space provided below.

NOTE: Reference to left hand and right hand used throughout this manual refers to the position when seated in the operator's seat facing forward.

SPRAYER SERIAL NUMBER

ENGINE SERIAL NUMBER

PLANETARY HUB IDENTIFICATION NUMBERS

<u>QTY.</u>	<u>PART NO.</u>	<u>DESCRIPTION</u>
1	311530	PRIMARY ELEMENT FOR 311528
1	311531	SAFETY ELEMENT FOR 311528
1	316207	LUBE FILTER CUMMINS DIESEL 92
1	316208	FUEL FILTER, PRIMARY CUMM 92
1	316209	FUEL FILTER, SECONDARY CUMM92
1	605602	PARKER FILTER ELEMENT, 10MICRON
1	605609	HYD FILTER ELEMENT, DONALDSON
1	657424	A/C PAPER AIR FILTER
1	657425	A/C CHARCOAL AIR FILTER

TABLE OF CONTENTS

ENGINE ASSEMBLIES . . . . . 4-6

FLOW DIVIDER . . . . . 7

AIR TANK ASSEMBLY . . . . . 8-9

FLUSHING VALVE . . . . . 10-11

A/C AND RADIATOR . . . . . 12-13

AIR CLEANER AND EXHAUST PIPE . . . . . 14

HYDRAULIC TUBING . . . . . 15

HYDRAULIC TANK . . . . . 16

LEG ASSEMBLIES . . . . . 17-25

STEERING CYLINDER . . . . . 26

BATTERY . . . . . 27

CAB ASSEMBLY . . . . . 28-32

INSTRUMENT PANEL ASSEMBLY . . . . . 33

SWITCH PANEL ASSEMBLY . . . . . 34

CONSOLE ASSEMBLY . . . . . 35-37

SEAT AND MONITOR . . . . . 38-39

WINDSHIELD WASHER . . . . . 40

SELECTOR VALVE AND VFC . . . . . 41-42

BOOM CRADLE . . . . . 43

SHEET METAL . . . . . 44-45

LADDER AND FUEL TANK . . . . . 46-47

SERVICE PLATFORM ASSEMBLY . . . . . 48

SOLUTION TANK . . . . . 49-53

SOLUTION SYSTEM . . . . . 54-56

BOOM VALVE . . . . . 57

TRANSOM, BOOM, AND LIFT COMPONENTS . . . . . 58-65

TREAD ADJUSTMENT OPTION . . . . . 66-68

DROP NOZZLE AND HOSES . . . . . 69-70

JACK STAND ASSEMBLY . . . . . 71

DECALS . . . . . 72-73

HYDRAULIC SCHEMATIC . . . . . 74-79

ELECTRICAL SCHEMATIC . . . . . 80-89

ABBREVIATIONS . . . . . 90

INDEX . . . . . 91

ENGINE ASSEMBLY

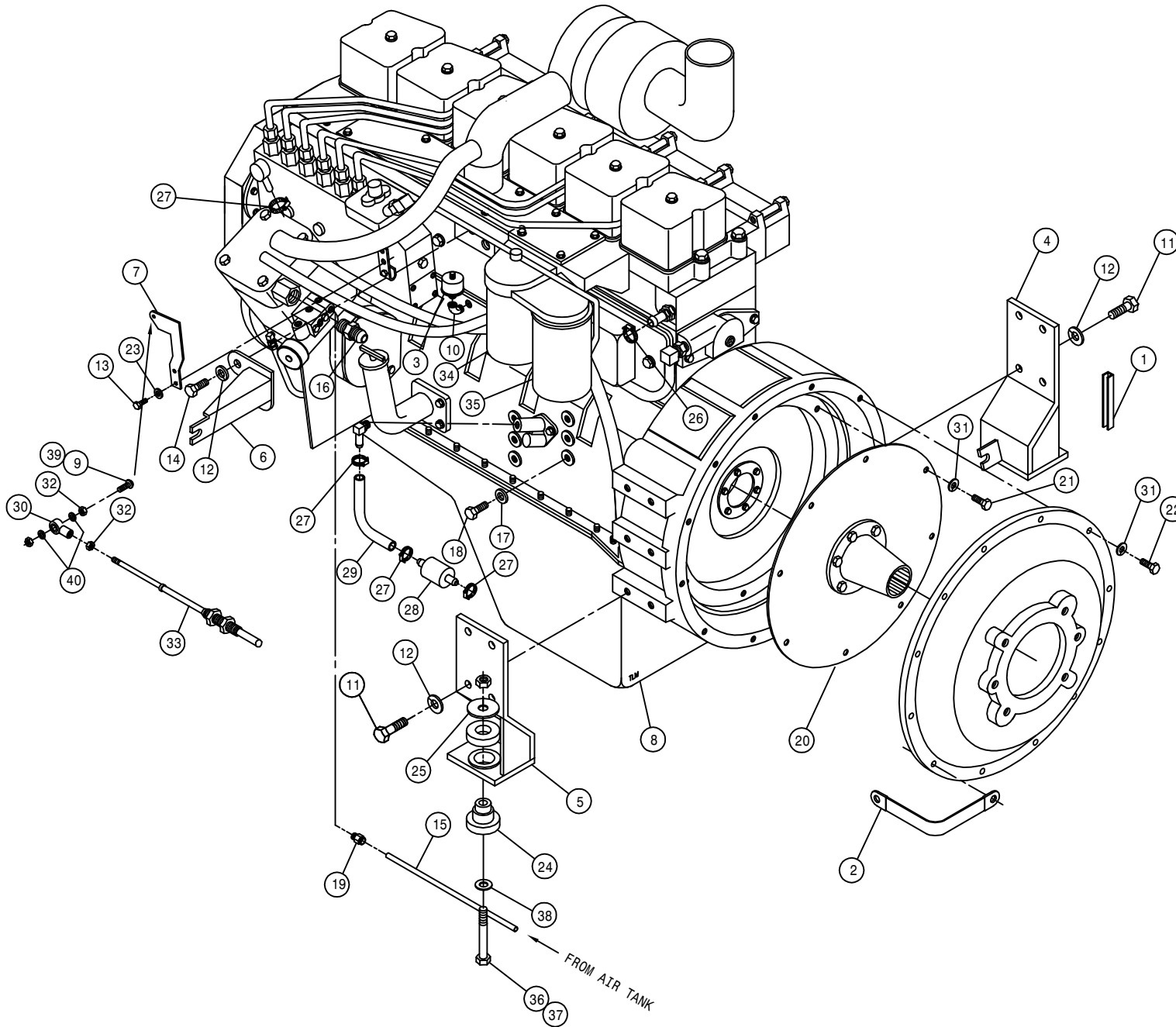

DET.	QTY	PART NO.	DESCRIPTION
	1	193012	QUICKEDGE TRIM .135 TO .250
	1	290107	GROUND CABLE, 8" X 4GA .406LUGS
	1	291674	OIL PRESS SENDER, 125PSI, 1/8NPT
	4	316252	RH REAR ENG MT WLD, CUMM 94
	5	316253	LH REAR ENG MT WLD, CUMM 94
	6	316517	THROTTLE CABLE MT WLD, CUMM 02
	7	316629	THROTTLE CABLE LEVER, CUMM 05
	8	316568	CUMM ENG, 6B5.9A 152@2500 CMPSR
	9	903893	10-32 X 1" SLT RD HD MACH SCR
	10	500900	BLK PIPE ST EL 90DEG .125NPT
	11	473855	12MM-1.75 X 35MM HEX BOLT
	12	473784	12MM LOCK WASHER
	13	473826	6MM-1.00 X 16MM HEX BOLT
	14	473828	12MM-1.50 X 20MM HEX BOLT
	15	601619	HOSE, 1/4 X 27 AIR
	16	610300	3/4MJIC-3/4MNPT ADPTR
	17	473804	8MM LOCK WASHER
	18	473827	8MM-1.25 X 20MM HEX BOLT
	19	711036	1/8MNPT-1/4 NYL TUBE FTG
	20	800503	DRIVE DISK ASSY, 11.5" 23T SPL
	21	473793	10MM-1.50 X 20MM HEX BOLT
	22	473792	10MM-1.50 X 30MM HEX BOLT
	23	473768	6MM LOCK WASHER
	24	311054	RUBBER MOUNT SET, CB-2202-4
	25	311055	REBOUND WASHER FOR 311054
	26	520055	HOSE CLAMP NO 12 STAINLESS
	27	520120	HOSE CLAMP NO 4 STAINLESS
	28	316281	FUEL STRAINER, IN-LINE, DIESEL
	29	601528	HOSE, 3/8 X 9 FUEL LINE
	30	473921	BALL JOINT NO 10-32 THD
	31	473798	10MM LOCK WASHER
	32	910027	10-32 HEX NUT
	33	785066	CTRL CABLE 10-32 4IN X 129 IN
	34	316208	FUEL FILTER, PRIMARY CUMM 92
	35	316209	FUEL FILTER, SECONDARY CUMM92
	36	900271	1/2UNC X 3 1/4 HEX BOLT
	37	914008	1/2UNC HEX STOVER NUT
	38	920004	1/2 SAE FLAT WASHER
	39	914027	10-32 HEX STOVER NUT
	40	920510	#10 LOCK WASHER

ENGINE ASSEMBLY

DET. QTY PART NO. DESCRIPTION

1	1	193012	QUICKEDGE TRIM .135 TO .250
2	1	291815	CIRCUIT BREAKER,100 AMP BUSS
3	1	291852	RELAY, 40 AMP, VF4 SERIES
4	1	314832	RADIATOR HOSE 1.75 X 19(52423)
5	1	314836	TEMP SENDR 280D 1/2NPT FOR GA
6	1	316180	FAN, 22" 6 BLADE 30DEG 2.25PIT
7	1	316199	22IN FAN SPACER CUMM 92
8	1	316250	RH FRT ENG MT WLD, CUMM 94
9	1	316568	CUMM ENG,6B5.9A 152@2500 CMPSR
10	1	316313	LH FRT ENG MT WLD, 284 CUMM 98
11	1	316631	BREAKER MTG PLT, DTS 8/8T 05
12	1	316340	BREAKER COVER, 2100 98
13	4	470175	10-32 HEX FLANGE LOCK NUT
14	4	470216	10-32 X 3/4 FLANGE HEX BOLT
15	6	473855	12MM-1.75 X 35MM HEX BOLT
16	2	473782	12MM-1.75 X 18MM HEX BOLT
17	8	473784	12MM LOCK WASHER
18	4	473804	8MM LOCK WASHER
19	4	473822	8MM-1.25 X 70MM HEX BOLT
20	2	520067	HOSE CLAMP NO 28 STAINLESS
21	1	618573	5/8 HOSE BARB-90-1/2MNPT
22	1	903883	10-32 X 1/2 SLT RDHD MACH SCR
23	1	316216	STARTER FOR CUMM 6 CYL 316185
24	6	910027	10-32 HEX NUT
25	2	311053	RUBBER MOUNT SET,SSB26-1000-1
26	1	314886	RADIATOR HOSE 2 1/4 20717
27	1	470118	1/4UNC X 3/4 FLANGE HEX BOLT
28	1	470121	1/4UNC HEX FLANGE LOCK NUT
29	4	900265	1/2UNC X 1 1/2 HEX BOLT
30	1	520055	HOSE CLAMP NO 12 STAINLESS
31	2	900271	1/2UNC X 3 1/4 HEX BOLT
32	6	914008	1/2UNC HEX STOVER NUT
33	6	920004	1/2 SAE FLAT WASHER
34	1	520126	CUSH HOSE CLAMP 2IN X 5/8W
35	2	520099	HOSE CLAMP NO 40 STAINLESS
36	1	316206	POLY V BELT CUMMINS DIESEL 92
37	1	316207	LUBE FILTER CUMMINS DIESEL 92
38	1	341968	TIE PLT 250/280 CUMM 92
39	1	316367	DELCO ALTERNATOR,130 AMP 22SI

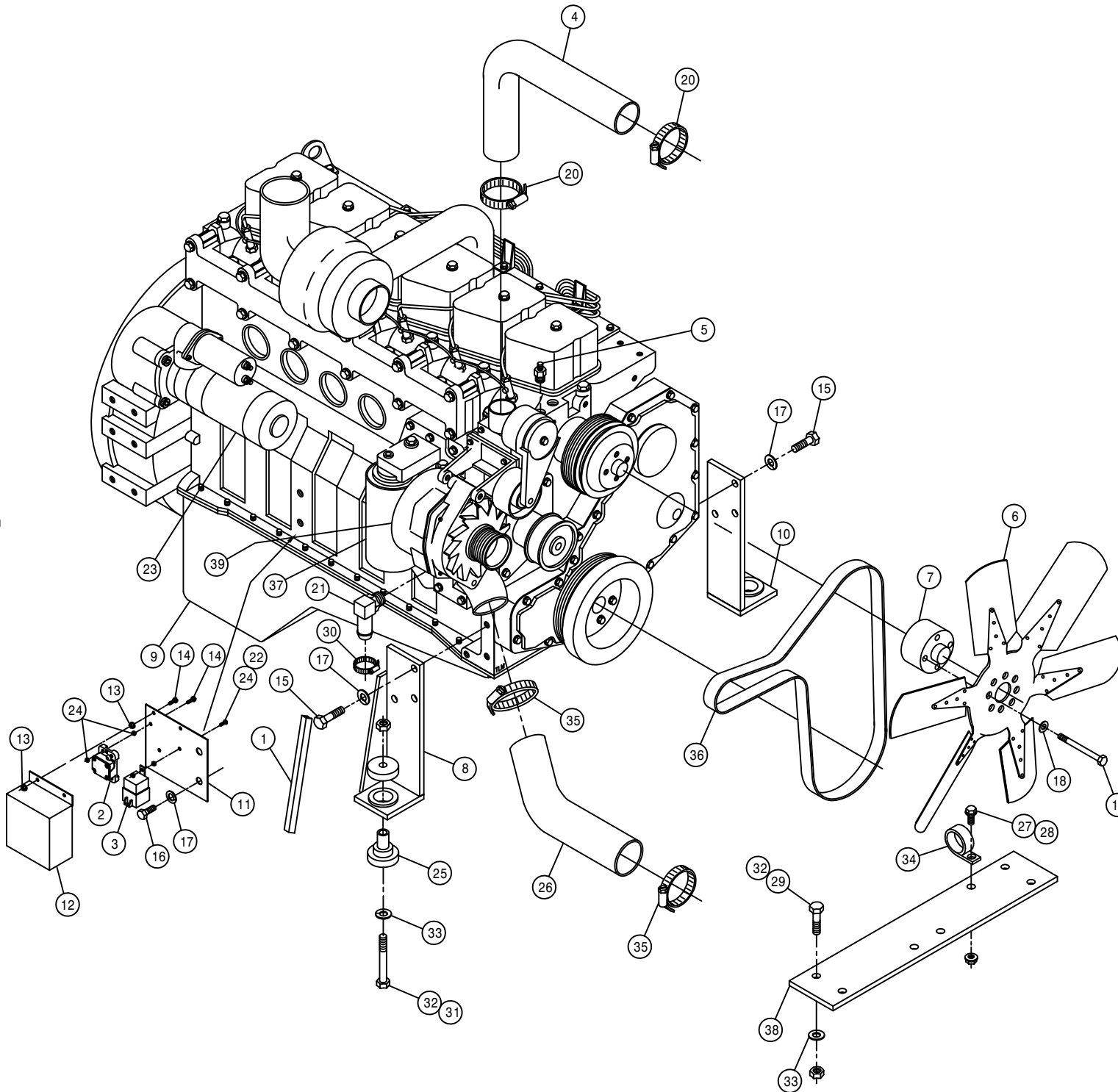

5

406005

HYDROSTATIC PUMP ASSEMBLY

DET. QTY PART NO. DESCRIPTION

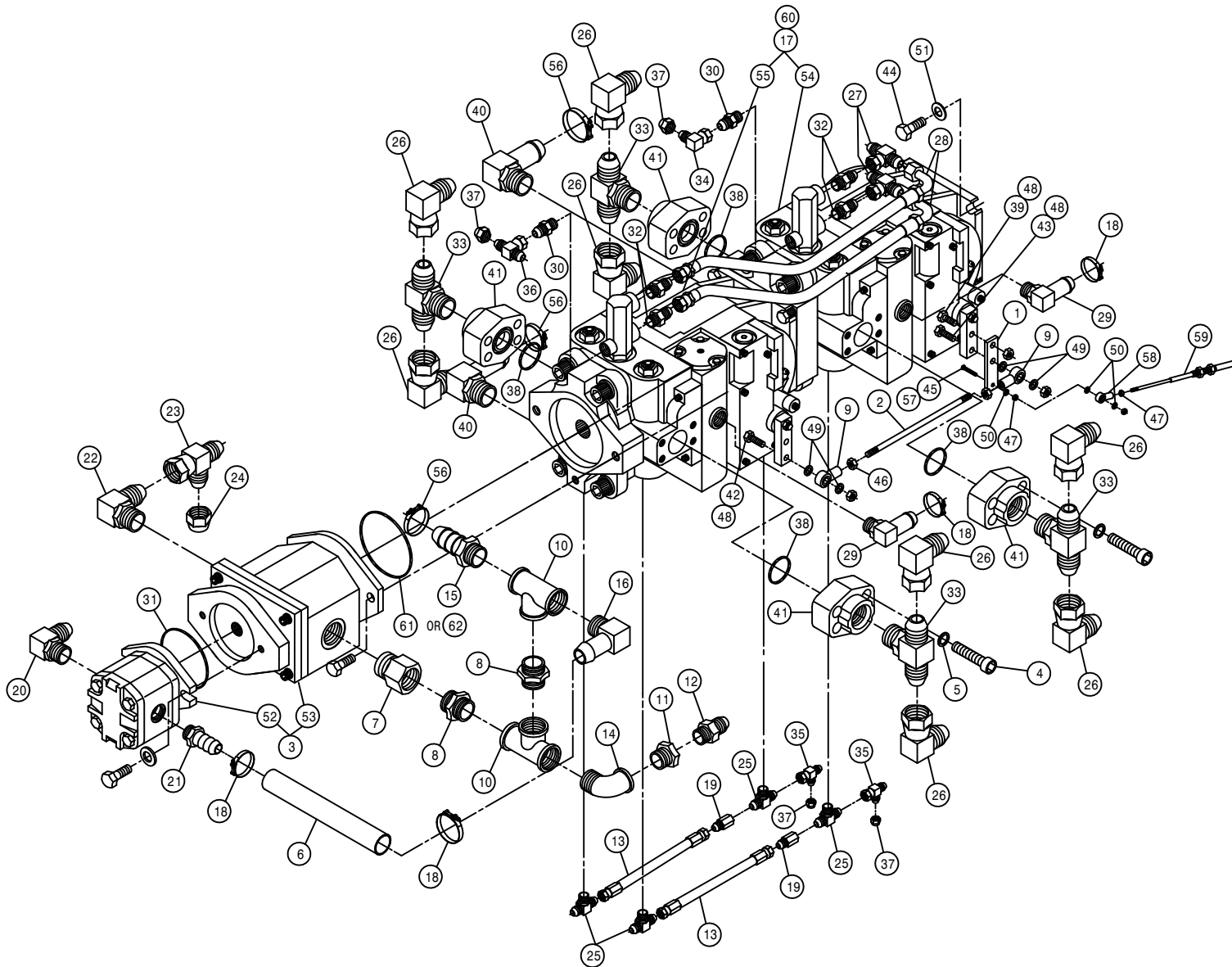

DET.	QTY	PART NO.	DESCRIPTION
1	1	316160	PUMP CONT LEVER EXT 280 CUMM
2	1	316335	HYDST PUMP CTRL ROD, 2100 UHM
3	1	606941	TANDEM PUMP, 606929 & 606932
4	16	470188	7/16-14 X 1 3/4 SKTHD CAP SCR
5	16	470189	7/16 HC LOCK WASH FOR 618598
6	1	601399	HOSE, 3/4 X 13 1FBR-19PI
7	1	618090	1 5/16MOR-1FNPT ADPTR
8	2	505105	1MNPT HEX PIPE NIPPLE STL
9	2	473998	BALL JOINT,1/4-28 1/4BORE
10	2	505101	BLK PIPE TEE 1.00NPT
11	1	505213	RED BUSH 1 X 3/4 BLK MAL
12	1	610300	3/4MJIC-3/4MNPT ADPTR
13	2	616252	04C2AT-06FJX-06FJX-13 H/A
14	1	505200	BLK PIPE ST EL 90DEG 1.00NPT
15	1	714560	1NPT X 1 HOSE BARB
16	1	716000	3/4 HOSE BARB-90-1MNPT
17	1	606230	TANDEM PUMP,606231/606234 .022
18	4	520137	1.12/1.25 T-BOLT HOSE CLAMP
19	2	618734	9/16JIC .047 ORIFICE ADPTR
20	1	618183	3/4MJIC-90-7/8MOR LBO
21	1	618075	3/4 HOSE BARB-1 1/16MOR
22	1	618535	7/8MJIC-90-1 1/16MOR LBO
23	1	618333	7/8FJIC SW RUN TEE-7/8MJIC
24	1	618328	7/8FJIC CAP NUT
25	4	618629	9/16MOR BRANCH TEE-9/16MJIC
26	8	618640	1 5/16MJ-90-1 5/16FJ SWIV LBO
27	2	618643	3/4FJ SW BRANCH TEE-3/4MJ
28	2	614739	08C1T-08FJX-08FJX90-16 H/A
29	2	618118	3/4 HOSE BARB-90-1 1/16MOR
30	2	618126	9/16MJIC-9/16MOR ADPTR
31	1	606924	O-RING FOR SUND A-MT
32	4	618327	3/4MJIC-7/8MOR ADPTR
33	4	618599	1 5/16MOR BRANCH TEE-1 5/16MJ
34	1	618618	9/16MJIC-90-9/16FJIC SWIV LBO
35	2	618486	9/16FJIC SW RUN TEE-9/16MJIC
36	1	618514	9/16FJ SW BRANCH TEE-9/16MJ
37	4	618531	9/16FJIC CAP NUT
38	4	870219	BUNA ORING 1 5/16 X 1 9/16
39	1	900003	1/4UNC X 1" HEX BOLT
40	2	618564	1IN HOSE BARB-90-1 5/16MOR
41	4	618598	1" 4-BOLT FLG X 1 5/16 FOR
42	1	900004	1/4UNC X 1 1/4 HEX BOLT
43	1	900005	1/4UNC X 1 1/2 HEX BOLT
44	4	900265	1/2UNC X 1 1/2 HEX BOLT
45	1	903893	10-32 X 1" SLT RD HD MACH SCR
46	2	910001	1/4UNF HEX NUT
47	2	910027	10-32 HEX NUT
48	3	914000	1/4UNC HEX STOVER NUT
49	4	920500	1/4 LOCK WASHER
50	3	920510	#10 LOCK WASHER
51	4	920004	1/2 SAE FLAT WASHER
52	1	606929	SUND GEAR PUMP .66CI, SPLINED
53	1	606932	SUND GEAR PUMP,1.60CI,SPLINED
54	1	606231	SUND 75CC PUMP,C/C MT (.022)
55	1	606234	SUND 75CC PUMP, C/B MT (.022)
56	3	520138	1.38/1.56 T-BOLT HOSE CLAMP
57	1	914027	10-32 HEX STOVER NUT
58	1	473921	BALL JOINT NO 10-32 THD
59	1	785003	CTRL CABLE 10-32 4IN X 112 LG
60	1	606950	O-RING, SUND 9004100-0480
61	1	606870	O-RING FOR 606865 SUND B-MT
62	1	606357	O-RING, SAUER 9004104-1540

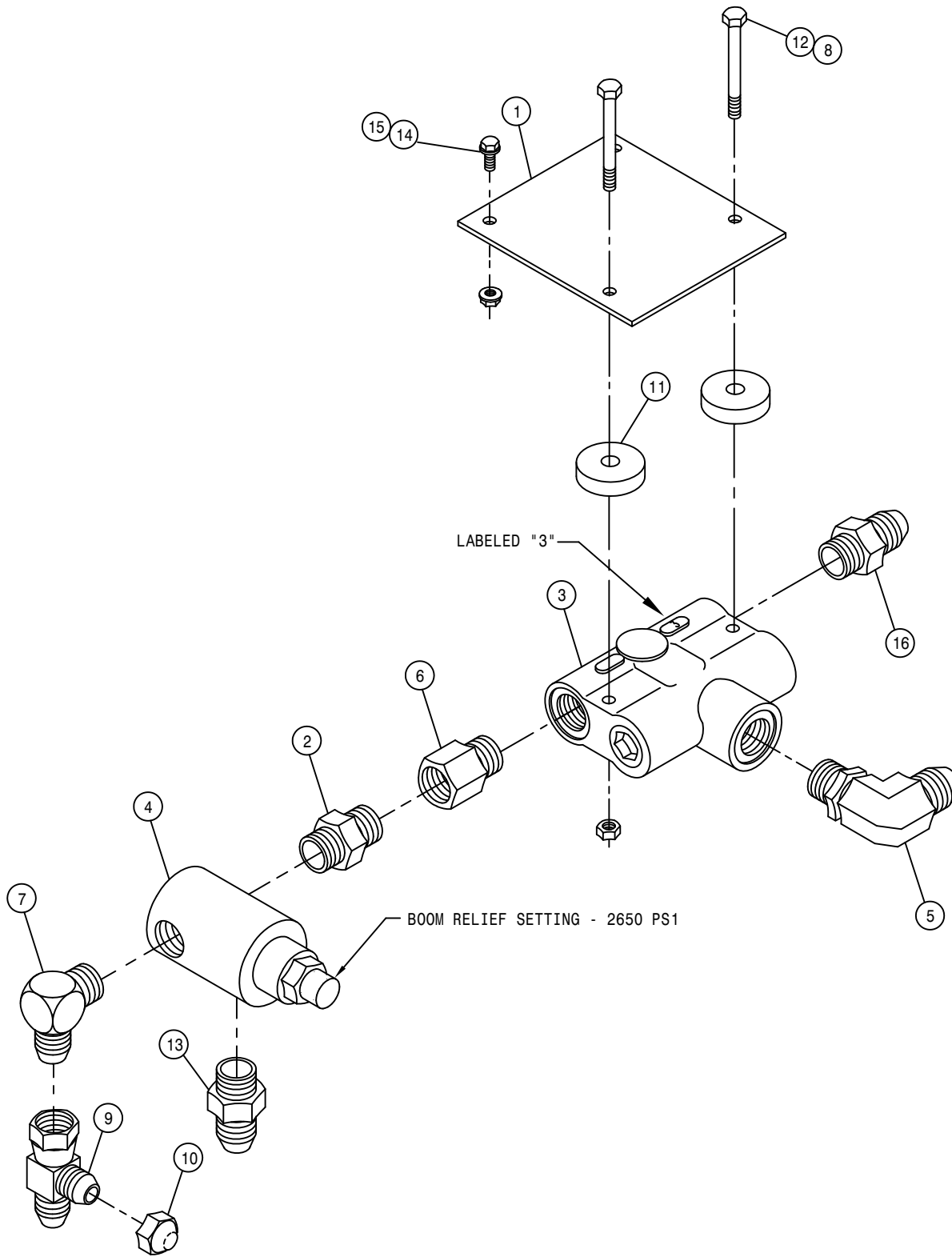

FLOW DIVIDER ASSEMBLY

DET. QTY PART NO. DESCRIPTION

1	1	343183	FLOW CTRL MT PLT, DTS8T	07
2	1	500000	9/16MJIC-1/2MNPT ADPTR	
3	1	610307	FLO DIV BG53 3GPM PRI 7/8FOR	
4	1	607512	RELIEF VALVE, RL50, 1850 PSI	
5	1	618183	3/4MJIC-90-7/8MOR LBO	
6	1	618072	7/8MOR-1/2FNPT ADPTR	
7	1	618107	9/16MJIC-90-1/2MNPT LBO	
8	2	914000	1/4UNC HEX STOVER NUT	
9	1	618486	9/16FJIC SW RUN TEE-9/16MJIC	
10	1	618531	9/16FJIC CAP NUT	
11	2	748500	RUBER WASH 3/8X1/4IDX1 1/2 OD	
12	2	900008	1/4UNC X 2 1/2 HEX BOLT	
13	1	618018	9/16MJIC-1/2MNPT ADPTR	
14	2	470118	1/4UNC X 3/4 FLANGE HEX BOLT	
15	2	470121	1/4UNC HEX FLANGE LOCK NUT	
16	1	618310	9/16MJIC-7/8MOR ADPTR	

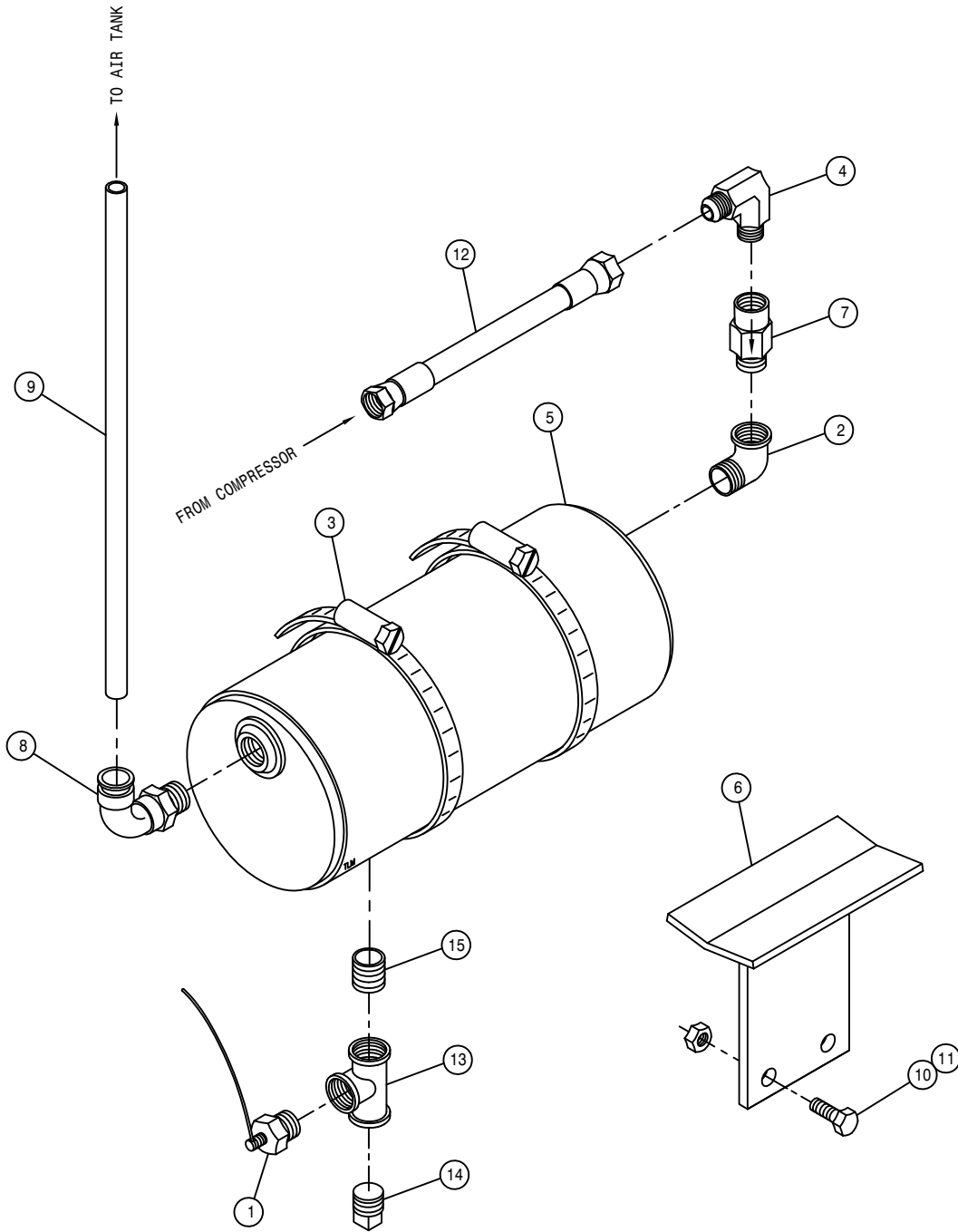

AIR WET TANK ASSEMBLY

DET. QTY PART NO. DESCRIPTION

1	1	470266	DRAIN VALVE KIT, 1/4NPT	
2	1	503400	BLK PIPE ST EL 90DEG .50NPT	
3	2	520086	HOSE CLAMP NO 88 STAINLESS	
4	1	611145	3/4MJIC-90-1/2MNPT LBO	
5	1	701115	WET TANK WLD	98
6	1	701146	WET TANK MTG BRKT WLD, 284	99
7	1	711032	CHECK VALVE, 1/2"FNPT-1/2"MNPT	
8	1	711042	1/2MNPT-1/2 NYL TUBE LBO	
9	1	601441	HOSE, 1/2 X 20 AIR	
10	2	900129	3/8UNC X 1" HEX BOLT	
11	2	914004	3/8UNC HEX STOVER NUT	
12	1	611301	08P919-08FJX-08FJX-18	H/A
13	1	501101	BLK PIPE TEE .25NPT	
14	1	501102	1/4 PIPE PLUG	
15	1	501601	CLOSE NIPPLE .25NPT	



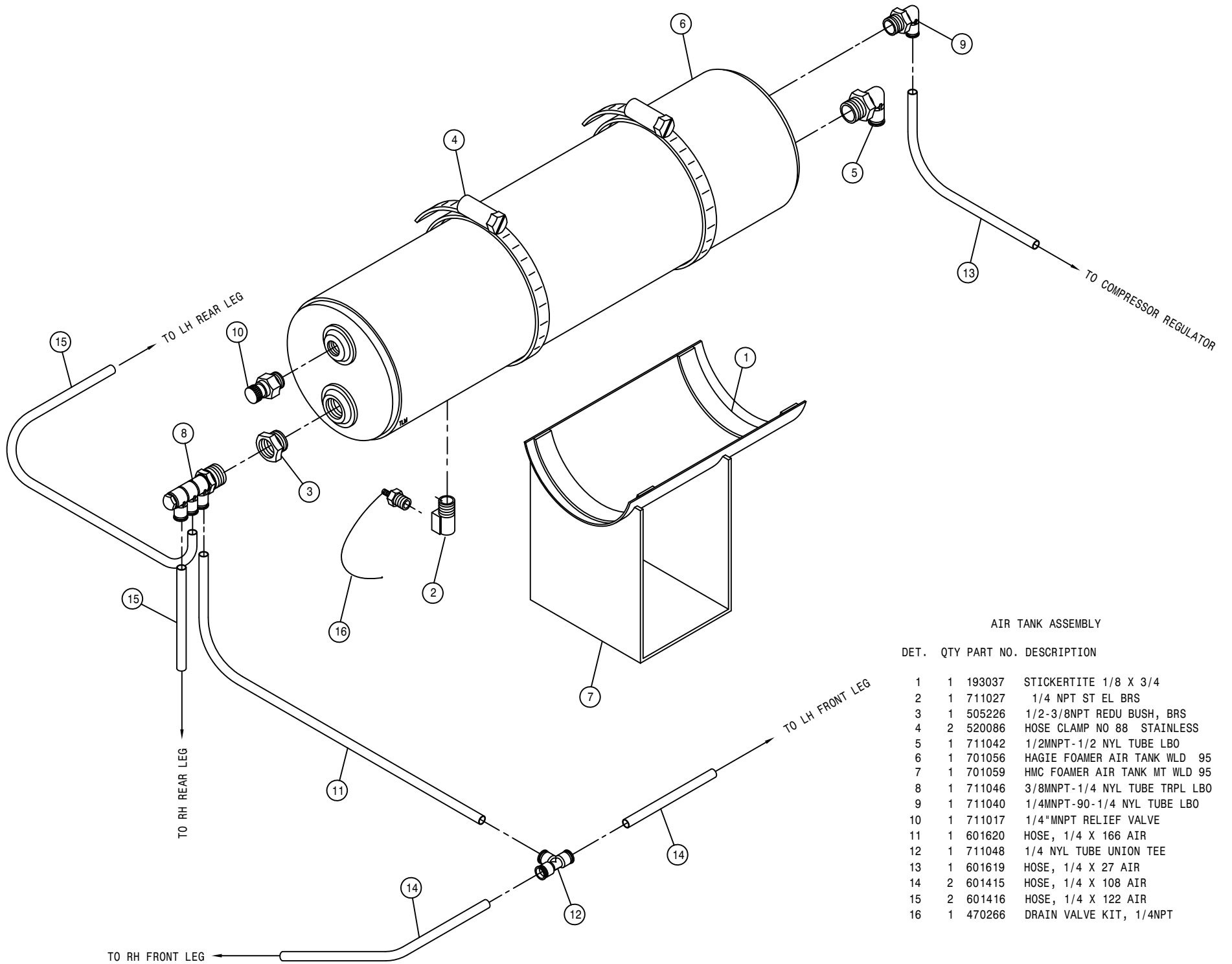

AIR TANK ASSEMBLY

DET.	QTY	PART NO.	DESCRIPTION
1	1	193037	STICKERTITE 1/8 X 3/4
2	1	711027	1/4 NPT ST EL BRS
3	1	505226	1/2-3/8NPT REDU BUSH, BRS
4	2	520086	HOSE CLAMP NO 88 STAINLESS
5	1	711042	1/2MNPT-1/2 NYL TUBE LBO
6	1	701056	HAGIE FOAMER AIR TANK WLD 95
7	1	701059	HMC FOAMER AIR TANK MT WLD 95
8	1	711046	3/8MNPT-1/4 NYL TUBE TRPL LBO
9	1	711040	1/4MNPT-90-1/4 NYL TUBE LBO
10	1	711017	1/4"MNPT RELIEF VALVE
11	1	601620	HOSE, 1/4 X 166 AIR
12	1	711048	1/4 NYL TUBE UNION TEE
13	1	601619	HOSE, 1/4 X 27 AIR
14	2	601415	HOSE, 1/4 X 108 AIR
15	2	601416	HOSE, 1/4 X 122 AIR
16	1	470266	DRAIN VALVE KIT, 1/4NPT

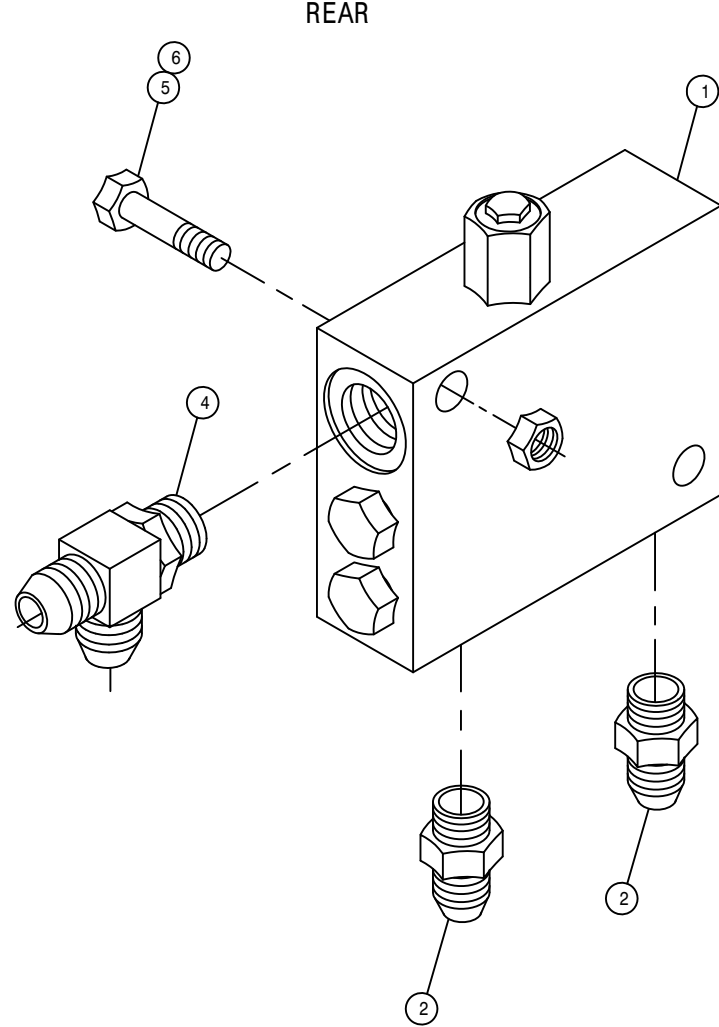
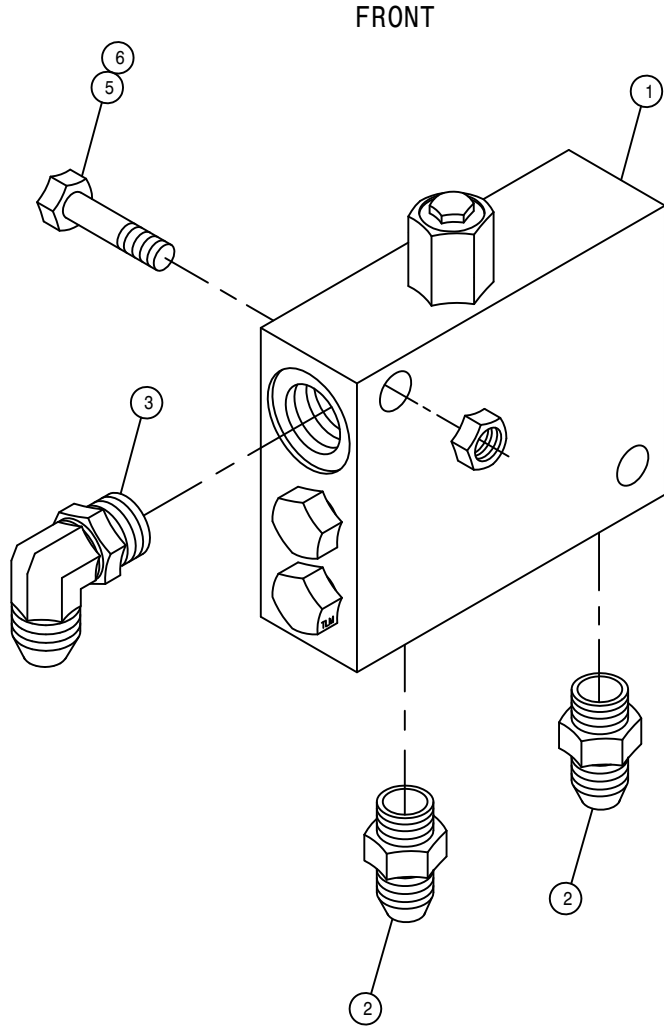

LOOP FLUSHING VALVE ASSEMBLY

DET. QTY PART NO. DESCRIPTION

1	2	610580	REMOTE FLUSHING VALVE, SUND
2	4	618126	9/16MJC-9/16MOR ADPTR
3	1	618119	9/16MJC-90-9/16MOR LBO
4	1	618444	9/16MOR RUN TEE-9/16MJC
5	4	900133	3/8UNC X 2" HEX BOLT
6	4	914004	3/8UNC HEX STOVER NUT

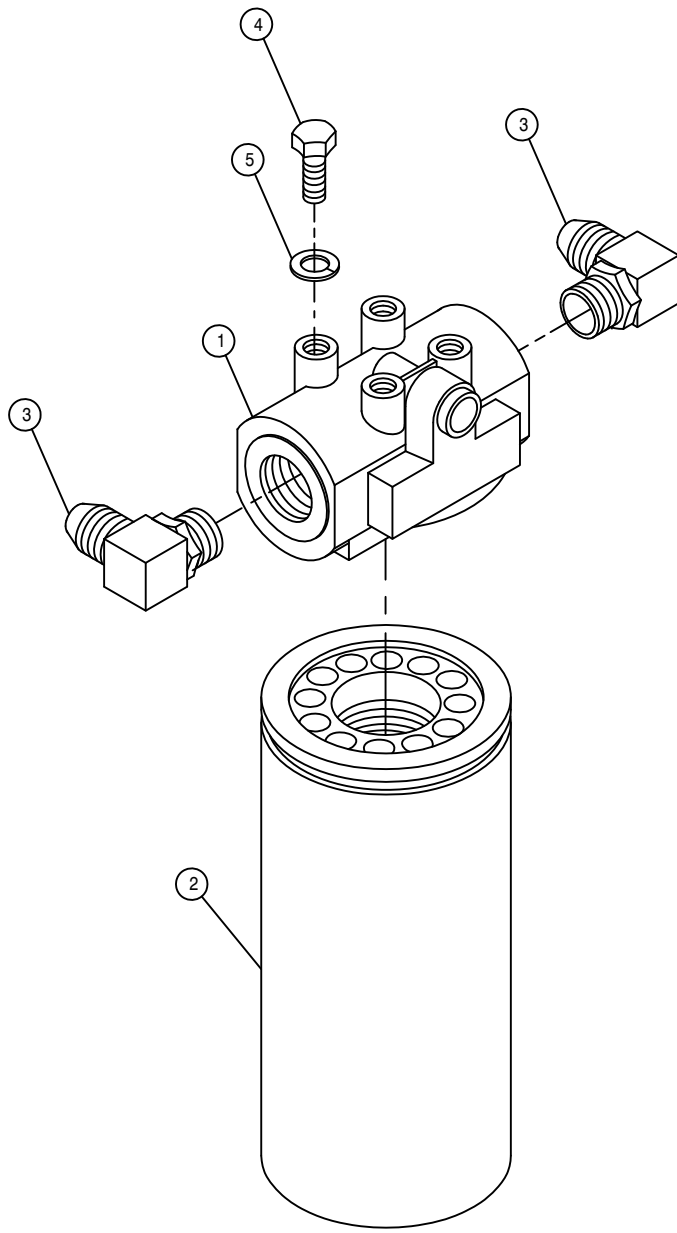

HI-PRESS FILTER ASSEMBLY

DET.	QTY	PART NO.	DESCRIPTION
1	1	605608	HYD FILTER HEAD, DONALDSON
2	1	605609	HYD FILTER ELEMENT, DONALDSON
3	2	618474	3/4MJIC-90-1 1/16MOR LBO
4	4	900128	3/8UNC X 3/4 HEX BOLT
5	4	920502	3/8 LOCK WASHER

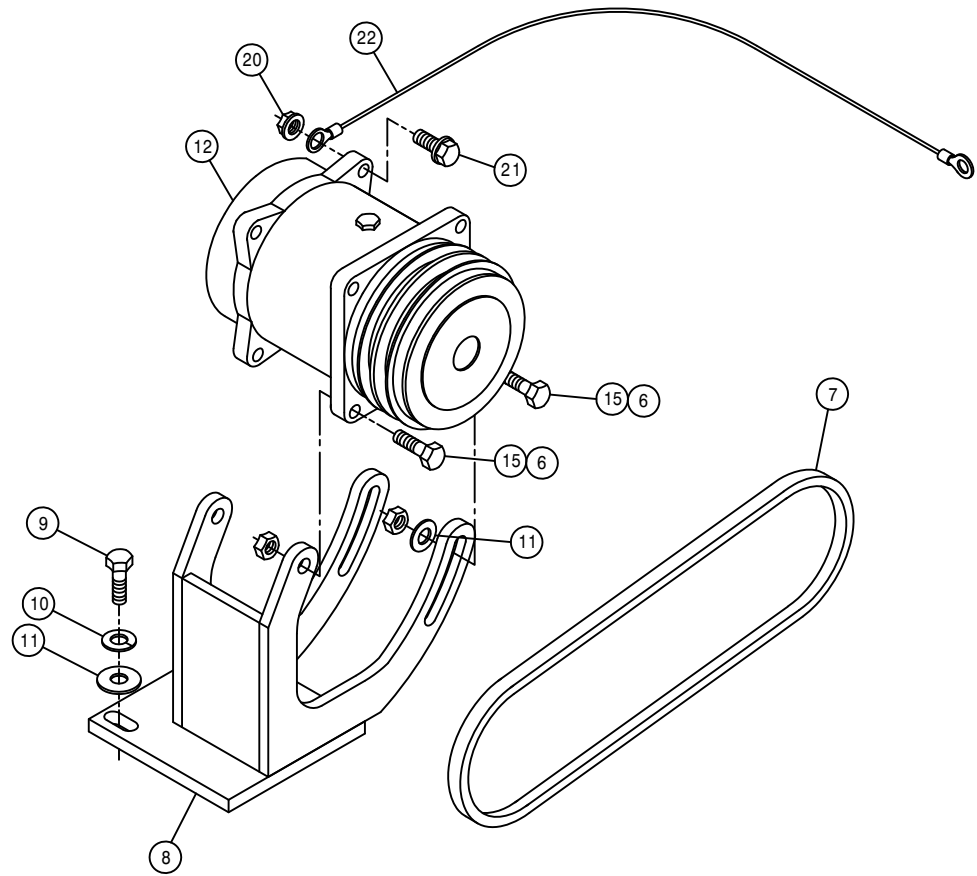
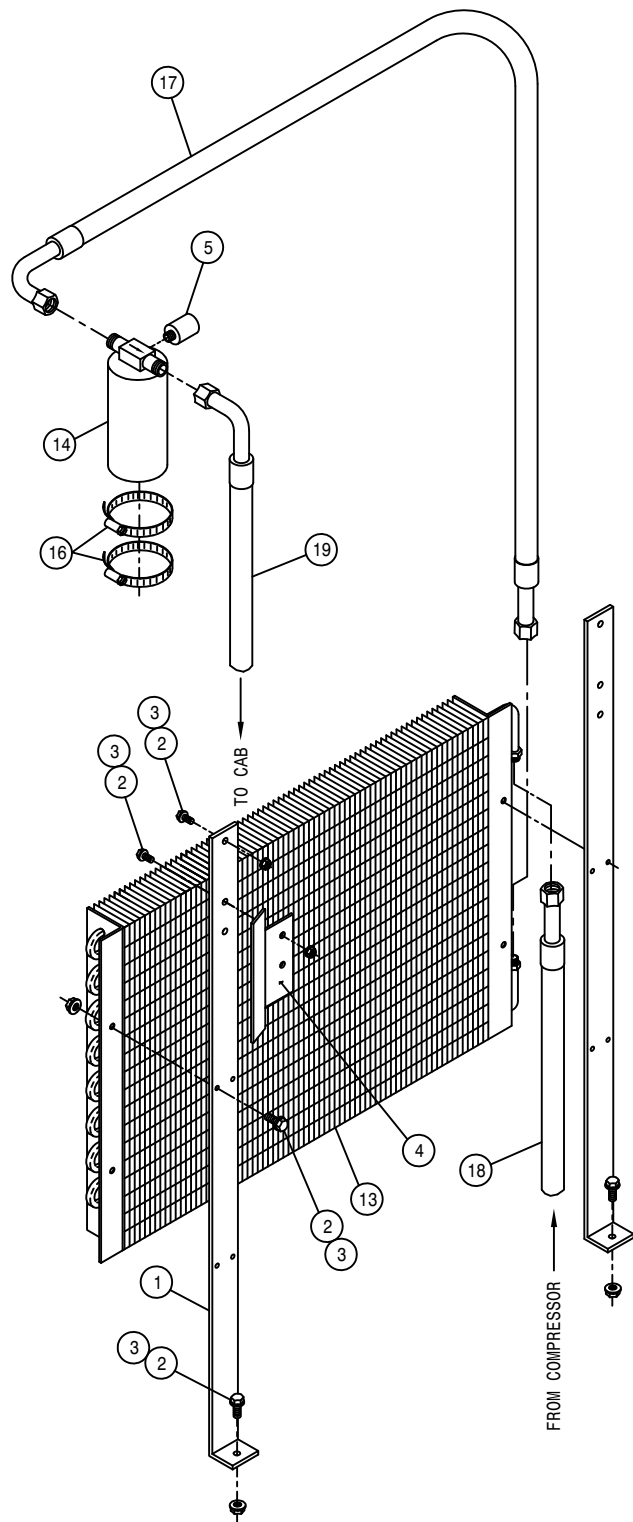

A/C COMPRESSOR PUMP ASSEMBLY

DET. QTY PART NO. DESCRIPTION

1	2	315036	CONDENSER MTG BRKT	99
2	10	470118	1/4UNC X 3/4 FLANGE HEX BOLT	
3	10	470121	1/4UNC HEX FLANGE LOCK NUT	
4	1	315038	A/C DRIER MT,204-254-284	99
5	1	657422	A/C BINARY SWITCH	
6	4	914004	3/8UNC HEX STOVER NUT	
7	1	147050	9455XL BELT, GATES	
8	1	316314	A/C COMPRSR MT WLD, 284	98
9	3	473792	10MM-1.50 X 30MM HEX BOLT	
10	3	473798	10MM LOCK WASHER	
11	5	483043	3/8 REGULAR FLAT WASHER	
12	1	657403	A/C COMP SR,180D PORTS TM15/12	
13	1	657423	A/C CONDENSER COIL 21-0324	
14	1	657421	A/C RECEIVER/DRIER	
15	4	900131	3/8UNC X 1 1/2 HEX BOLT	
16	2	520052	HOSE CLAMP NO 52 STAINLESS	
17	1	657429	A/C HOSE ASSY, 5/16 X 44	
18	1	657430	A/C HOSE ASSY, 13/32 X 80	
19	1	657431	A/C HOSE ASSY, 5/16 X 173	
20	1	470087	3/8UNC HEX FLANGE LOCK NUT	
21	1	470329	3/8UNC X 1 1/4 FLANGE HEX BOLT	
22	1	293564	16GA BLK-291512-291590-36	

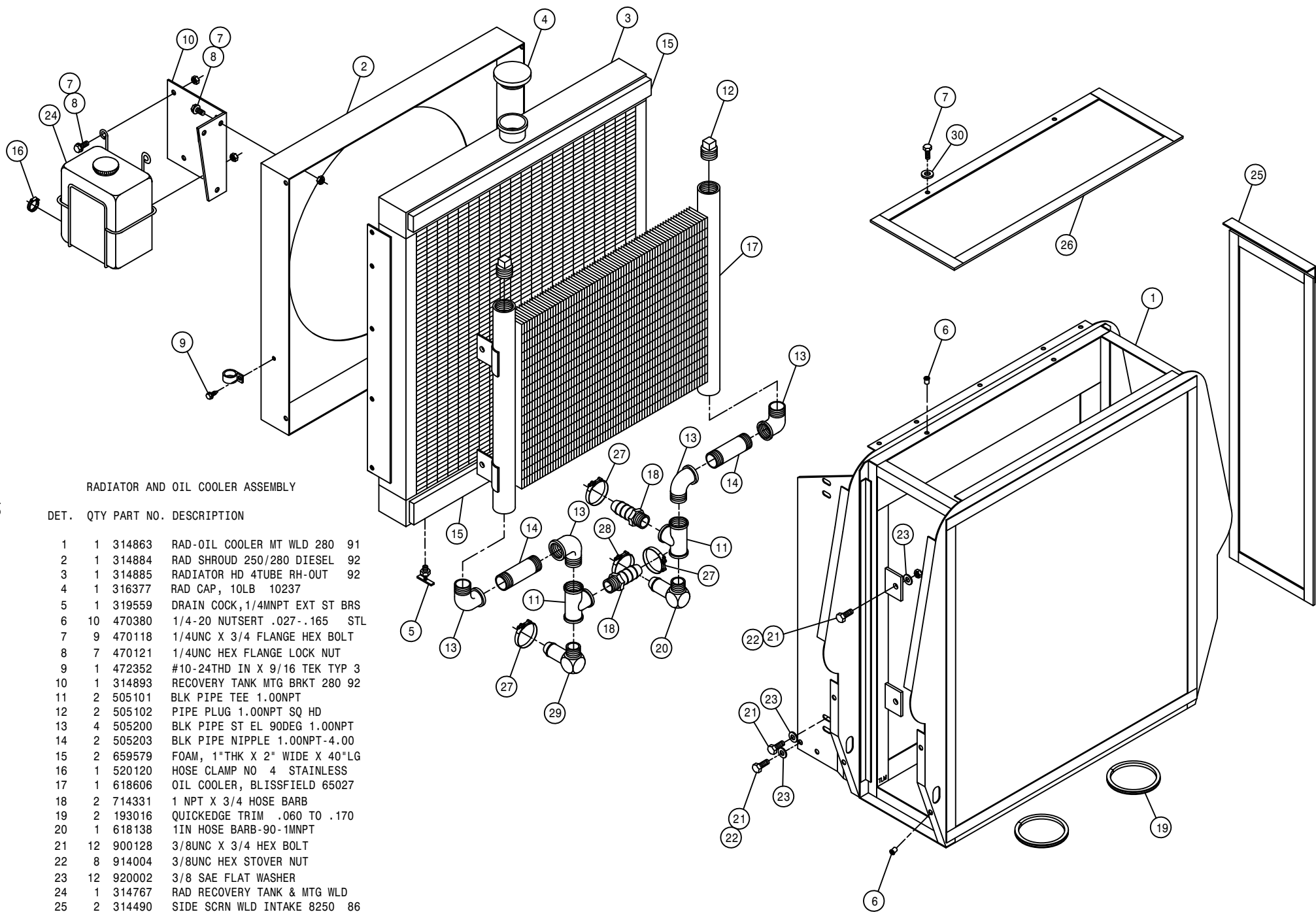

## RADIATOR AND OIL COOLER ASSEMBLY

DET. QTY PART NO. DESCRIPTION

1	1	314863	RAD-OIL COOLER MT WLD 280	91
2	1	314884	RAD SHROUD 250/280 DIESEL	92
3	1	314885	RADIATOR HD 4TUBE RH-OUT	92
4	1	316377	RAD CAP, 10LB 10237	
5	1	319559	DRAIN COCK, 1/4MNPT EXT ST BRS	
6	10	470380	1/4-20 NUTSERT .027-.165 STL	
7	9	470118	1/4UNC X 3/4 FLANGE HEX BOLT	
8	7	470121	1/4UNC HEX FLANGE LOCK NUT	
9	1	472352	#10-24THD IN X 9/16 TEK TYP 3	
10	1	314893	RECOVERY TANK MTG BRKT 280	92
11	2	505101	BLK PIPE TEE 1.00NPT	
12	2	505102	PIPE PLUG 1.00NPT SQ HD	
13	4	505200	BLK PIPE ST EL 90DEG 1.00NPT	
14	2	505203	BLK PIPE NIPPLE 1.00NPT-4.00	
15	2	659579	FOAM, 1"THK X 2" WIDE X 40"LG	
16	1	520120	HOSE CLAMP NO 4 STAINLESS	
17	1	618606	OIL COOLER, BLISSFIELD 65027	
18	2	714331	1 NPT X 3/4 HOSE BARB	
19	2	193016	QUICKEDGE TRIM .060 TO .170	
20	1	618138	1IN HOSE BARB-90-1MNPT	
21	12	900128	3/8UNC X 3/4 HEX BOLT	
22	8	914004	3/8UNC HEX STOVER NUT	
23	12	920002	3/8 SAE FLAT WASHER	
24	1	314767	RAD RECOVERY TANK & MTG WLD	
25	2	314490	SIDE SCR N WLD INTAKE 8250	86
26	1	314495	TOP SCR N WLD INTAKE 8250	86
27	3	520137	1.12/1.25 T-BOLT HOSE CLAMP	
28	1	520138	1.38/1.56 T-BOLT HOSE CLAMP	
29	1	716000	3/4 HOSE BARB-90-1MNPT	
30	2	470212	1/4 BONDED SEALING WASH, SS	

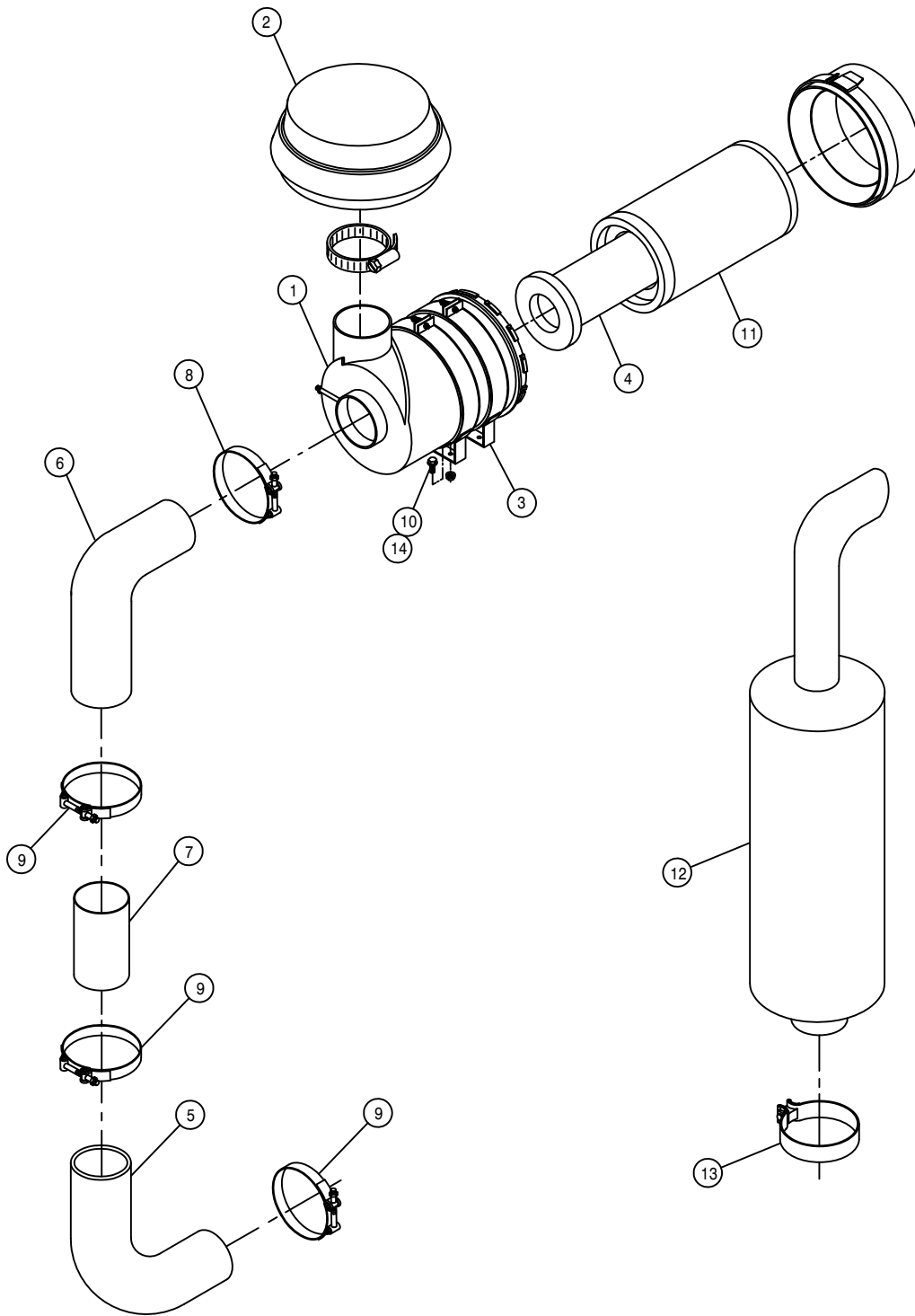

AIR CLEANER AND EXHAUST PIPE

DET. QTY PART NO. DESCRIPTION

DET.	QTY	PART NO.	DESCRIPTION
1	1	311528	AIR CLEANER, PLASTIC HSNG
2	1	314971	AIR CLEANER HOOD FOR 314970
3	2	311529	AIR CLEANER MT BAND FOR 311528
4	1	311531	SAFETY ELEMENT FOR 311528
5	1	316309	4" 90DEG ELBOW, RUBBER
6	1	316297	5" -4" 90DEG REDU ELBOW, RUBBER
7	1	316298	4" X 12" AIR INTAKE TUBE 97
8	1	520136	5.31/5.59 T-BOLT HOSE CLAMP SS
9	3	520134	4.31/4.59 T-BOLT HOSE CLAMP SS
10	4	470113	5/16UNC HEX FLANGE LOCK NUT
11	1	311530	PRIMARY ELEMENT FOR 311528
12	1	316366	MUFFLER, 2100/STS10/STS12
13	1	470458	MUFFLER CLAMP, 3.00 ACCUSEAL
14	4	470233	5/16UNC X 3/4 FLANGE HEX BOLT

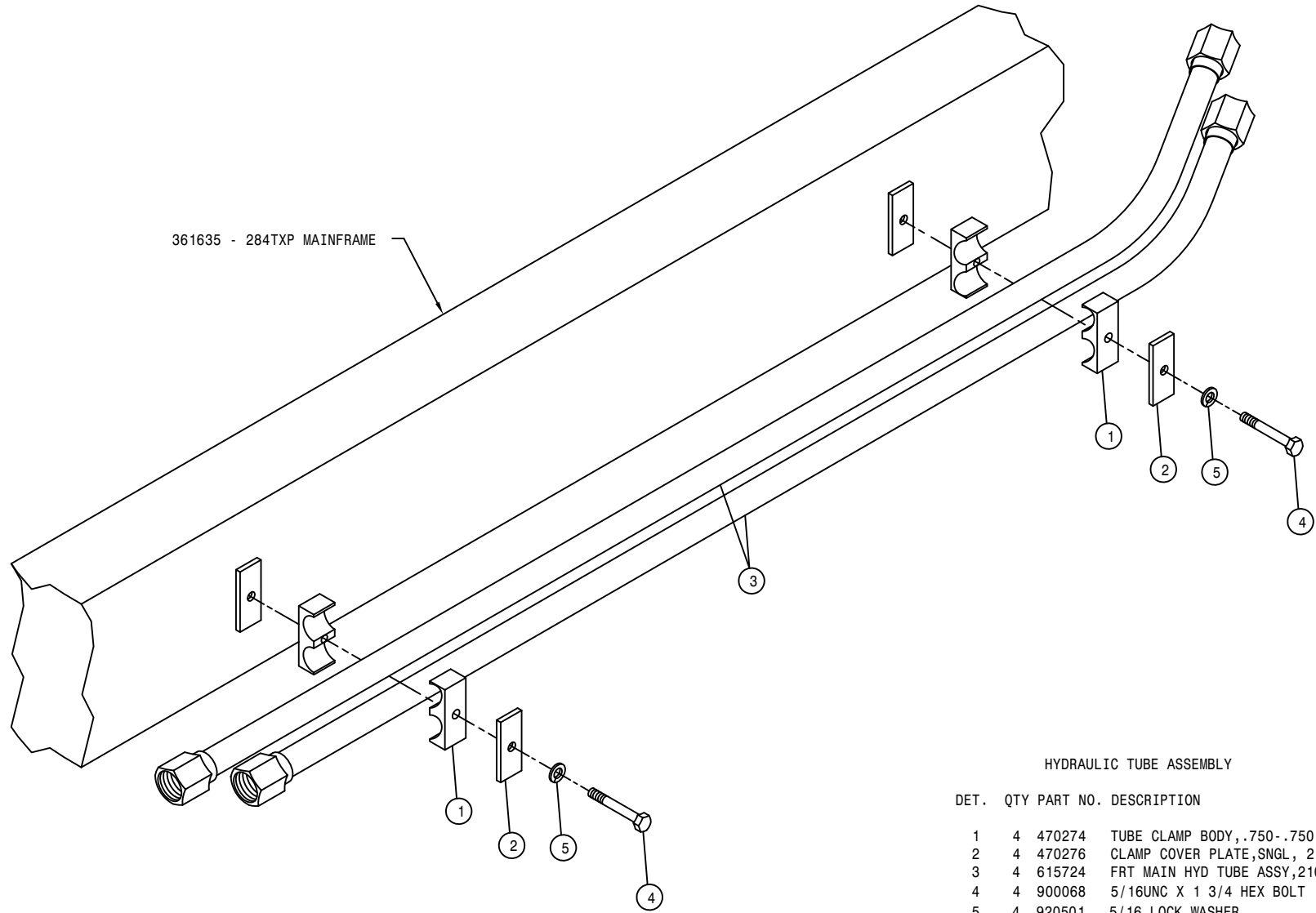

361635 - 284TXP MAINFRAME

HYDRAULIC TUBE ASSEMBLY

DET.	QTY	PART NO.	DESCRIPTION
1	4	470274	TUBE CLAMP BODY, .750-.750
2	4	470276	CLAMP COVER PLATE,SNGL, 2.55LG
3	4	615724	FRT MAIN HYD TUBE ASSY,2100 98
4	4	900068	5/16UNC X 1 3/4 HEX BOLT
5	4	920501	5/16 LOCK WASHER

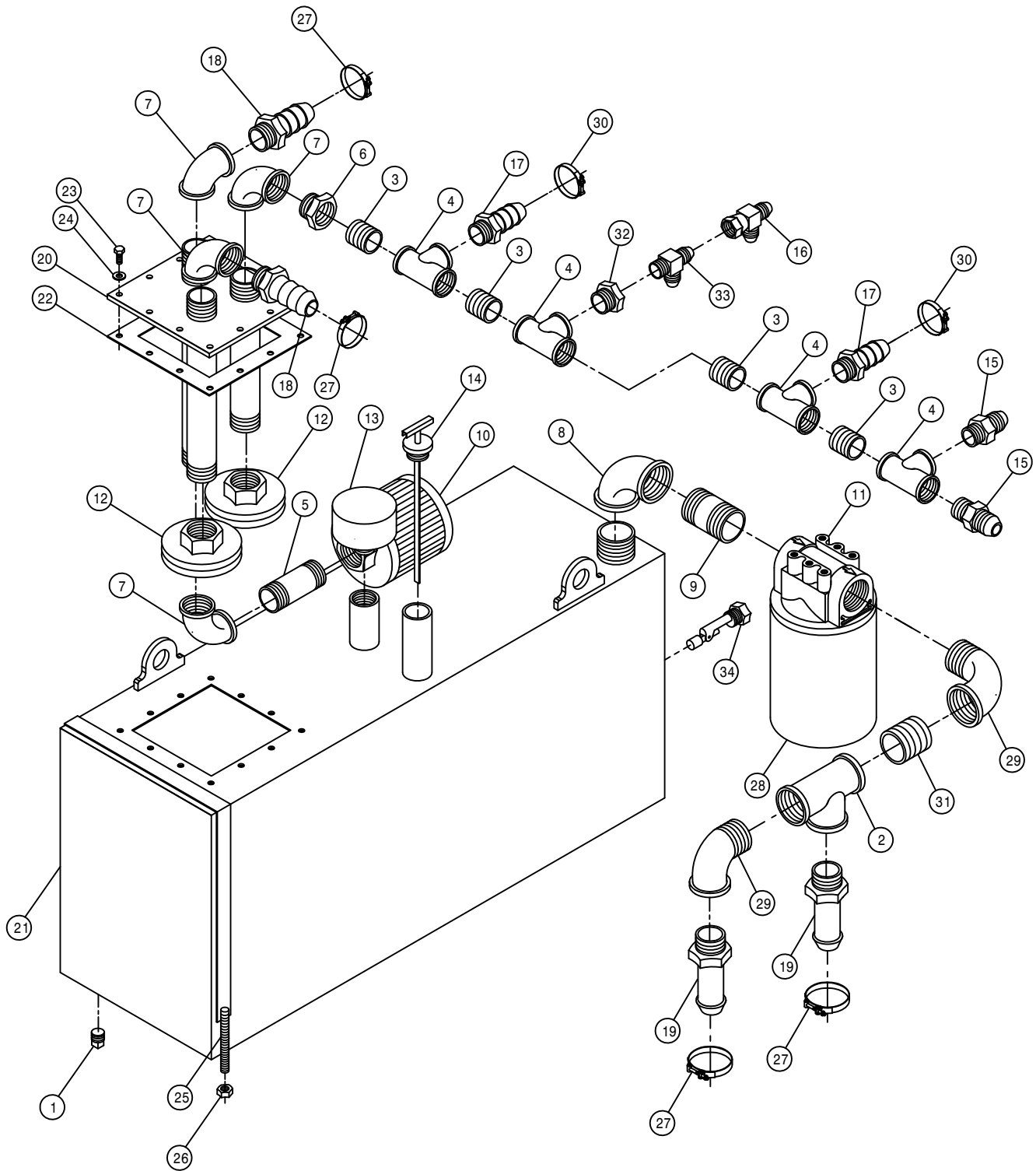

HYDRAULIC TANK ASSEMBLY

DET.	QTY	PART NO.	DESCRIPTION
1	1	470308	1/2MNPT DRAIN PLUG,AL HD,MAG
2	1	506105	BLK PIPE TEE 1.25NPT
3	4	504702	CLOSE NIPPLE .75NPT
4	4	504955	BLK PIPE TEE .75NPT
5	1	505203	BLK PIPE NIPPLE 1.00NPT-4.00
6	1	505213	RED BUSH 1 X 3/4 BLK MAL
7	4	505300	BLK PIPE EL 90DEG 1.00NPT
8	1	506303	BLK PIPE EL 90DEG 1.25NPT
9	1	506602	PIPE NIPPLE 1 1/4NPT-2 1/2
10	1	605600	TANK FILTER, 100 MESH,1"FNPT
11	1	605601	PARKER FILTER ASSY,10M,1.25NPT
12	2	605603	LINE SUMP DIFFUSER
13	1	611052	FILLER BREATHER 3/4NPT
14	1	614453	DIPSTICK, 8IN
15	2	610300	3/4MJIC-3/4MNPT ADPTR
16	1	618486	9/16FJIC SW RUN TEE-9/16MJIC
17	2	713220	HOSE BARB 3/4 NPT X 3/4
18	2	714560	1NPT X 1 HOSE BARB
19	2	715664	1 1/4 NPT X 1 HOSE BARB
20	1	760090	RECEIVER PLT WLD 8240
21	1	760264	HYD TANK WLD,204/254/284 2002
22	1	763039	HYD MTR MTG PLT GSKT
23	12	900064	5/16UNC X 3/4 HEX BOLT
24	12	920001	5/16 SAE FLAT WASHER
25	2	341360	OIL TANK STRAP WLD 8240 1982
26	4	914004	3/8UNC HEX STOVER NUT
27	4	520138	1.38/1.56 T-BOLT HOSE CLAMP
28	1	605602	PARKER FILTER ELEMENT,10MICRON
29	2	506410	BLK PIPE ST EL 90DEG 1.25NPT
30	2	520137	1.12/1.25 T-BOLT HOSE CLAMP
31	1	506200	CLOSE NIPPLE 1.25NPT
32	1	504001	RED BUSH 3/4 X 1/4 BLK MAL
33	1	618520	1/4MNPT RUN TEE-9/16MJIC
34	1	470350	LIQUID LEVEL SWITCH ASSY,1/2NPT



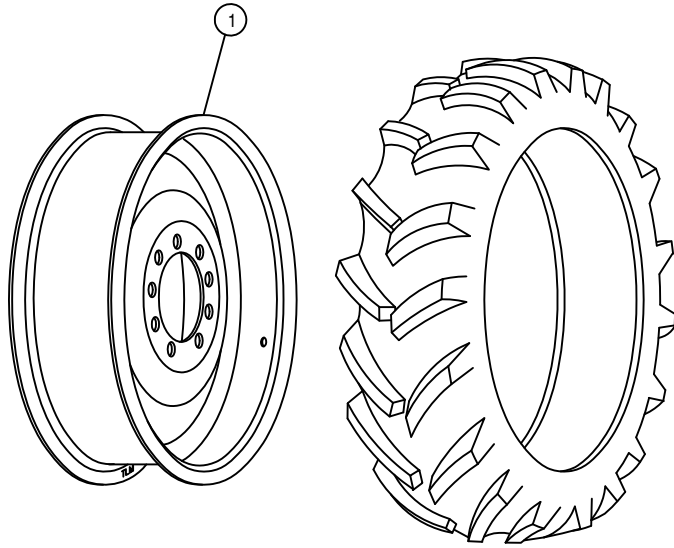

13.6-38 6 PLY TIRE

TIRE AND RIM ASSEMBLY

DET. QTY PART NO. DESCRIPTION

1	1	821050	RIM WLD, W10 X 38, W1M1	204
---	---	--------	-------------------------	-----

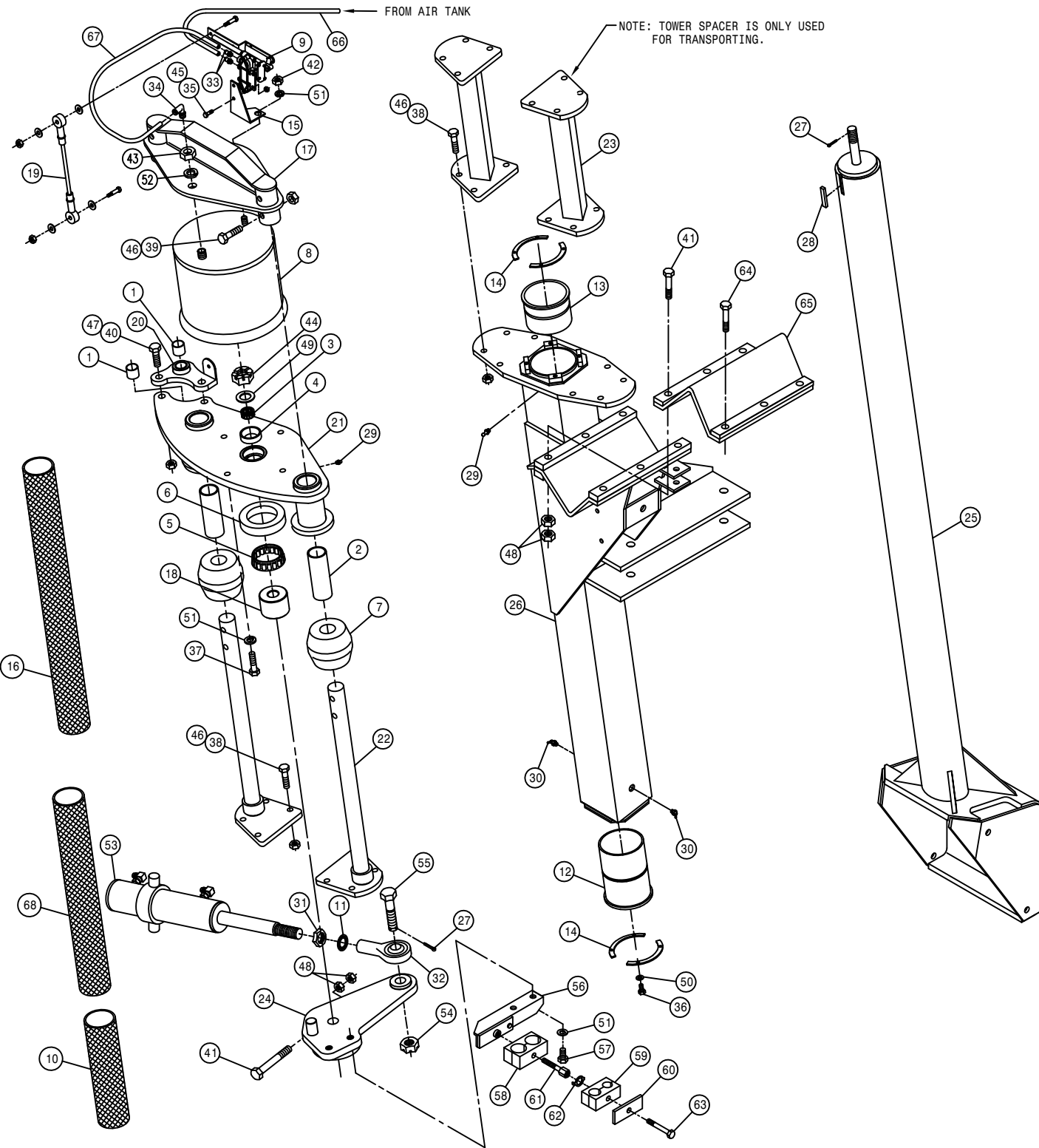

RIGHT FRONT LEG ASSEMBLY

DET.	QTY	PART NO.	DESCRIPTION
	1	2	121029 JOURNAL BRG, 1.00 ID X 1.00 LG
	2	2	121105 LEG TOWER SLIDE BEARING, ORKOT
	3	1	125050 BRG CONE, 1.00 ID W/FACE SEAL
	4	1	125051 BRG CUP FOR 125050
	5	1	125052 BRG CONE, 2.687 ID W/FACE SEAL
	6	1	125053 BRG CUP FOR 125052
	7	2	311058 RUBBER SPRING
	8	1	311066 AIRIDE SPRING, 9.75 BASE
	9	1	358832 AIRIDE SPRING CTRL VALVE 98
	10	1	342654 NYL HOSE SLEEVE, 3.66ID X 24.00
	11	1	483019 7/8" INTERNAL TOOTH LOCK WASHER
	12	1	358564 FRT LEG LWR NYL SLEEVE 280 89
	13	1	358565 FRT LEG UPR NYL SLEEVE 280 89
	14	4	358927 LWR BRG KPR, LEG 98
	15	1	359289 LH LEG AIR VALVE MT, STS 04
	16	1	342638 NYL HOSE SLEEVE, 2.96ID X 65.00
	17	1	359052 AIR BAG TOWER TOP MT WLD
	18	1	359082 STEERING ARM BRG SPACER
	19	1	359095 LEG HEIGHT CTRL LINKAGE, STS12
	20	1	359442 RH UPR TRUNN MT PLT WLD, DTS8T
	21	1	359226 RH AIR BAG LWR PLT WLD, 284TXP
	22	2	359230 NITRO TOWER SHAFT WLD, 284TXP03
	23	2	359232 TOWER SPACER WLD, 284TXP 03
	24	1	359235 RH STEERING ARM WLD, 284TXP 03
	25	1	359244 INNER LEG WLD, 284TXP 03
	26	1	359255 RH FRT OUTER LEG WLD, 284TXP 03
	27	2	470117 COTTER PIN 3/16 1 3/4 SQ CUT
	28	1	470265 KEY, .250 X .375 X 1.88 LG
	29	2	471005 1/4 28 X 1/2 GREASE ZERK
	30	2	471023 GREASE ZERK 1/4-28 X 45
	31	1	472322 7/8-14 UNF HEX JAM NUT
	32	1	473983 ROD END.875 BORE.875-14 RH FEM
	33	2	711036 1/8MNPT-1/4 NYL TUBE FTG
	34	1	711040 1/4MNPT-90-1/4 NYL TUBE LBO
	35	2	900002 1/4UNC X 3/4 HEX BOLT
	36	8	900064 5/16UNC X 3/4 HEX BOLT
	37	4	900265 1/2UNC X 1 1/2 HEX BOLT
	38	16	900266 1/2UNC X 1 3/4 HEX BOLT
	39	4	900269 1/2UNC X 2 3/4 HEX BOLT
	40	2	900352P 5/8UNC X 2 1/4 HEX BOLT
	41	4	900836 5/8UNF X 3 1/4 HEX BOLT GR8
	42	1	910008 1/2UNC HEX NUT
	43	1	910013 3/4UNF HEX NUT
	44	1	910021 1" - 14 SLOT JAM NUT
	45	2	914000 1/4UNC HEX STOVER NUT
	46	20	470360 1/2UNC HEX FLANGE LOCK NUT
	47	2	914010P 5/8UNC HEX STOVER NUT
	48	14	914811 5/8UNF HEX NUT GR8
	49	1	920008 1" SAE FLAT WASHER
	50	8	920501 5/16 LOCK WASHER
	51	7	920504 1/2 LOCK WASHER
	52	1	920506 3/4 LOCK WASHER
	53	1	621007 STEERING CYL ASSY, 284TXP 03
	54	1	825013 7/8-14UNF SLOTTED HEX NUT
	55	1	359239 STEERING ARM BOLT, 284TXP 03
	56	1	358996 RH UPPER HOSE MT WELD, 2100 99
	57	2	900263 1/2UNC X 1" HEX BOLT
	58	1	470347 HOSE CLAMP BODY, 1.16-1.16
	59	1	470282 HOSE CLAMP BODY, .53-.78
	60	1	470276 CLAMP COVER PLATE, SNGL, 2.55LG
	61	1	470280 STACK BOLT, 5/16UNC X 1 3/4
	62	1	470281 STACK BOLT SAFETY LOCK PLATE
	63	1	900068 5/16UNC X 1 3/4 HEX BOLT
	64	3	900837 5/8UNF X 3 1/2 HEX BOLT GR8
	65	1	358759 LEG MT V-PLT WLD, 284T 94
	66	1	601415 HOSE, 1/4 X 108 AIR
	67	1	601473 HOSE, 1/4 X 22 AIR
	68	1	342828 NYL HOSE SLEEVE, 3.34ID X 65.00

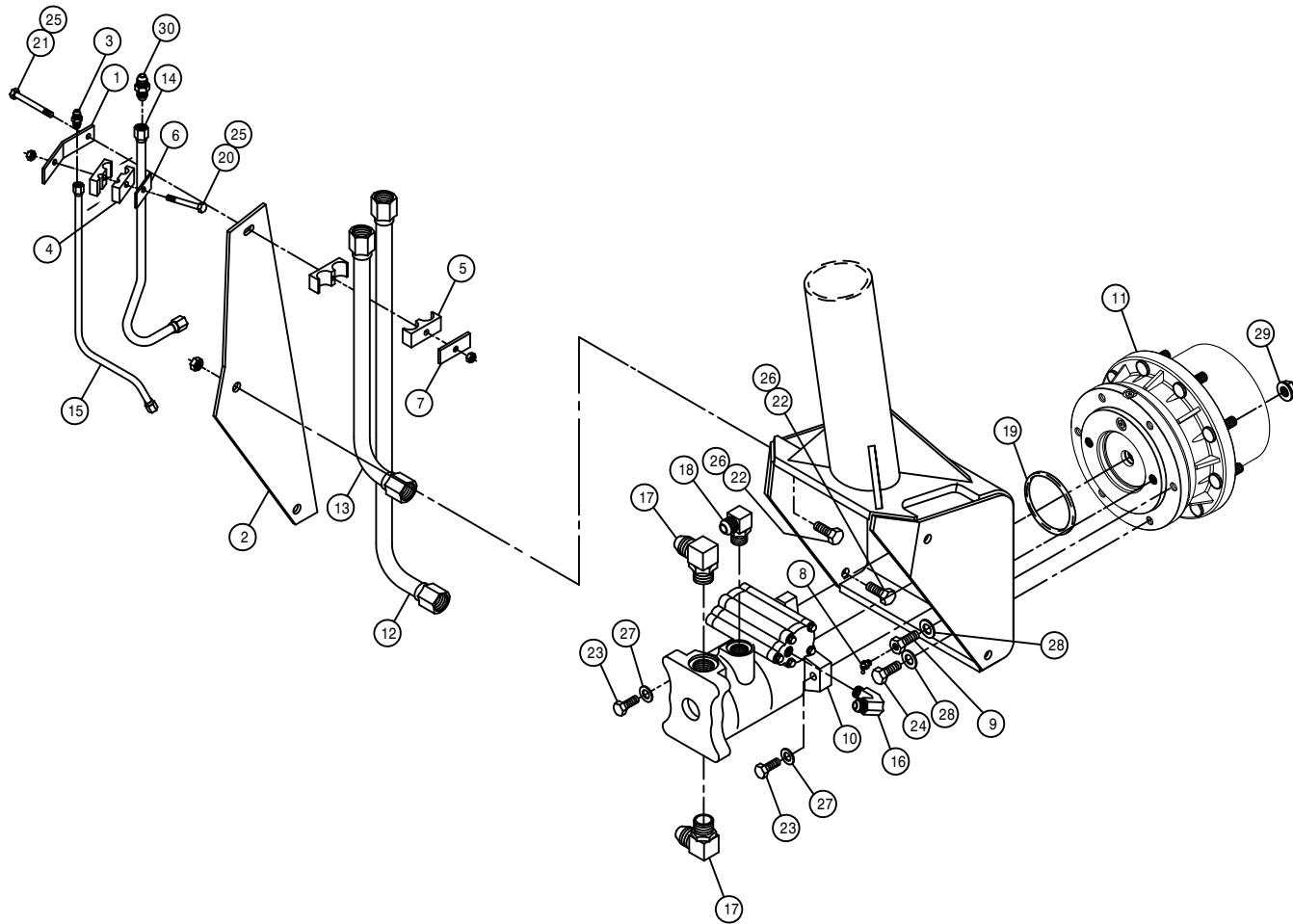

RIGHT FRONT LEG ASSEMBLY

DET.	QTY	PART NO.	DESCRIPTION
	1	358926	FRT LEG HYD TUBE BRKT, 2100 98
	1	359243	HYD TUBE MTG PLT, 284TXP 03
	1	619010	9/16MJIC UNION
	1	470272	TUBE CLAMP BODY, .375-.500
	1	470275	TUBE CLAMP BODY, 1.000-1.000
	1	470277	CLAMP WELD PLATE, SNGL, 2.15LG
	1	470278	CLAMP WELD PLATE, SNGL, 2.75LG
	1	471023	GREASE ZERK 1/4-28 X 45
	1	610013	ZERK BOLT, 5/8 X 1 1/4, TORQ HUB
	1	610637	SUND HYD MOTOR, M46-4019
	1	610844	TORQ HUB, 7HBX 29:1
	1	615708	LWR HYD TUBE ASSY, LEG 2100 98
	1	615709	UPR HYD TUBE ASSY, LEG 2100 98
	1	615710	RF/LR HYD DRN TUBE ASSY 2100 98
	1	615712	RF/LR HYD CTRL TUBE ASSY 210098
	1	618119	9/16MJIC-90-9/16MOR LBO
	2	618178	1 5/16MJIC-90-1 5/16MOR LBO
	1	618474	3/4MJIC-90-1 1/16MOR LBO
	1	870045	O-RING 4 1/8 OD X 4 ID
	1	900068	5/16UNC X 1 3/4 HEX BOLT
	1	900070	5/16UNC X 2 1/2 BOLT
	2	900264	1/2UNC X 1 1/4 HEX BOLT
	2	900266P	1/2UNC X 1 3/4 HEX BOLT
	5	900332P	5/8UNC X 1 1/4 HEX BOLT
	2	914002	5/16UNC HEX STOVER NUT
	2	470360	1/2UNC HEX FLANGE LOCK NUT
	2	920504P	1/2 LOCK WASHER
	6	920505P	5/8 LOCK WASHER
	9	470140	5/8UNF HEX SMTH FLANGE NUT PLT
	1	618314	3/4MJIC UNION

NOTE: TOWER SPACER IS ONLY USED FOR TRANSPORTING.

FROM AIR TANK

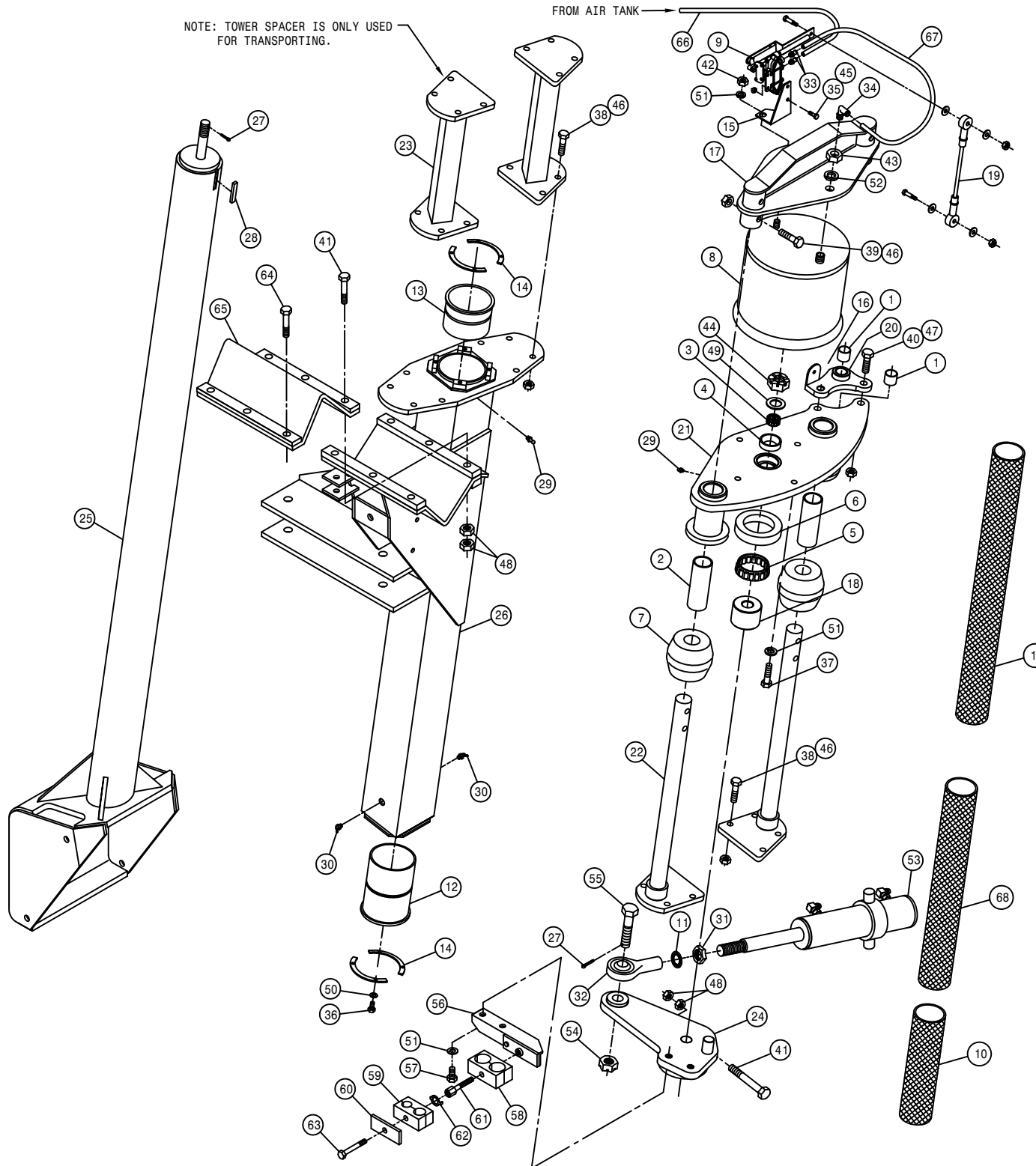

LEFT FRONT LEG ASSEMBLY

DET.	QTY	PART NO.	DESCRIPTION
1	2	121029	JOURNAL BRG, 1.00 ID X 1.00 LG
2	2	121105	LEG TOWER SLIDE BEARING, ORKOT
3	1	125050	BRG CONE, 1.00 ID W/FACE SEAL
4	1	125051	BRG CUP FOR 125050
5	1	125052	BRG CONE, 2.687 ID W/FACE SEAL
6	1	125053	BRG CUP FOR 125052
7	2	311058	RUBBER SPRING
8	1	311066	AIRIDE SPRING, 9.75 BASE
9	1	358832	AIRIDE SPRING CTRL VALVE 98
10	1	342654	NYL HOSE SLEEVE, 3.66ID X 24.00
11	1	483019	7/8" INTERNAL TOOTH LOCK WASHER
12	1	358564	FRT LEG LWR NYL SLEEVE 280 89
13	1	358565	FRT LEG UPR NYL SLEEVE 280 89
14	4	358927	LWR BRG KPR, LEG 98
15	1	359288	RH LEG AIR VALVE MT, STS 04
16	1	342638	NYL HOSE SLEEVE, 2.96ID X 65.00
17	1	359052	AIR BAG TOWER TOP MT WLD
18	1	359082	STEERING ARM BRG SPACER
19	1	359095	LEG HEIGHT CTRL LINKAGE, STS12
20	1	359441	UPPER TRUNNION MT WLD, DTS8T
21	1	359227	LH AIR BAG LWR PLT WLD, 284TXP
22	2	359230	NITRO TOWER SHAFT WLD, 284TXP03
23	2	359232	TOWER SPACER WLD, 284TXP 03
24	1	359236	LH STEERING ARM WLD, 284TXP 03
25	1	359244	INNER LEG WLD, 284TXP 03
26	1	359256	LH FRT OUTER LEG WLD, 284TXP 03
27	2	470117	COTTER PIN 3/16 1 3/4 SQ CUT
28	1	470265	KEY, .250 X .375 X 1.88 LG
29	2	471005	1/4 28 X 1/2 GREASE ZERK
30	2	471023	GREASE ZERK 1/4-28 X 45
31	1	472322	7/8-14 UNF HEX JAM NUT
32	1	473983	ROD END, .875 BORE, .875-14 RH FEM
33	2	711036	1/8MNPT-1/4 NYL TUBE FTG
34	1	711040	1/4MNPT-90-1/4 NYL TUBE LBO
35	2	900002	1/4UNC X 3/4 HEX BOLT
36	8	900064	5/16UNC X 3/4 HEX BOLT
37	4	900265	1/2UNC X 1 1/2 HEX BOLT
38	16	900266	1/2UNC X 1 3/4 HEX BOLT
39	4	900269	1/2UNC X 2 3/4 HEX BOLT
40	2	900352P	5/8UNC X 2 1/4 HEX BOLT
41	4	900836	5/8UNF X 3 1/4 HEX BOLT GR8
42	1	910008	1/2UNC HEX NUT
43	1	910013	3/4UNF HEX NUT
44	1	910021	1" -14 SLOT JAM NUT
45	2	914000	1/4UNC HEX STOVER NUT
46	20	470360	1/2UNC HEX FLANGE LOCK NUT
47	2	914010P	5/8UNC HEX STOVER NUT
48	14	914811	5/8UNF HEX NUT GR8
49	1	920008	1" SAE FLAT WASHER
50	8	920501	5/16 LOCK WASHER
51	7	920504	1/2 LOCK WASHER
52	1	920506	3/4 LOCK WASHER
53	1	621007	STEERING CYL ASSY, 284TXP 03
54	1	825013	7/8-14UNF SLOTTED HEX NUT
55	1	359239	STEERING ARM BOLT, 284TXP 03
56	1	358997	LH UPPER HOSE MT WELD, 2100 99
57	2	900263	1/2UNC X 1" HEX BOLT
58	1	470347	HOSE CLAMP BODY, 1.16-1.16
59	1	470282	HOSE CLAMP BODY, .53-.78
60	1	470276	CLAMP COVER PLATE, SNGL, 2.55LG
61	1	470280	STACK BOLT, 5/16UNC X 1 3/4
62	1	470281	STACK BOLT SAFETY LOCK PLATE
63	1	900068	5/16UNC X 1 3/4 HEX BOLT
64	3	900837	5/8UNF X 3 1/2 HEX BOLT GR8
65	1	358759	LEG MT V-PLT WLD, 284T 94
66	1	601415	HOSE, 1/4 X 108 AIR
67	1	601473	HOSE, 1/4 X 22 AIR
68	1	342828	NYL HOSE SLEEVE, 3.34ID X 65.00

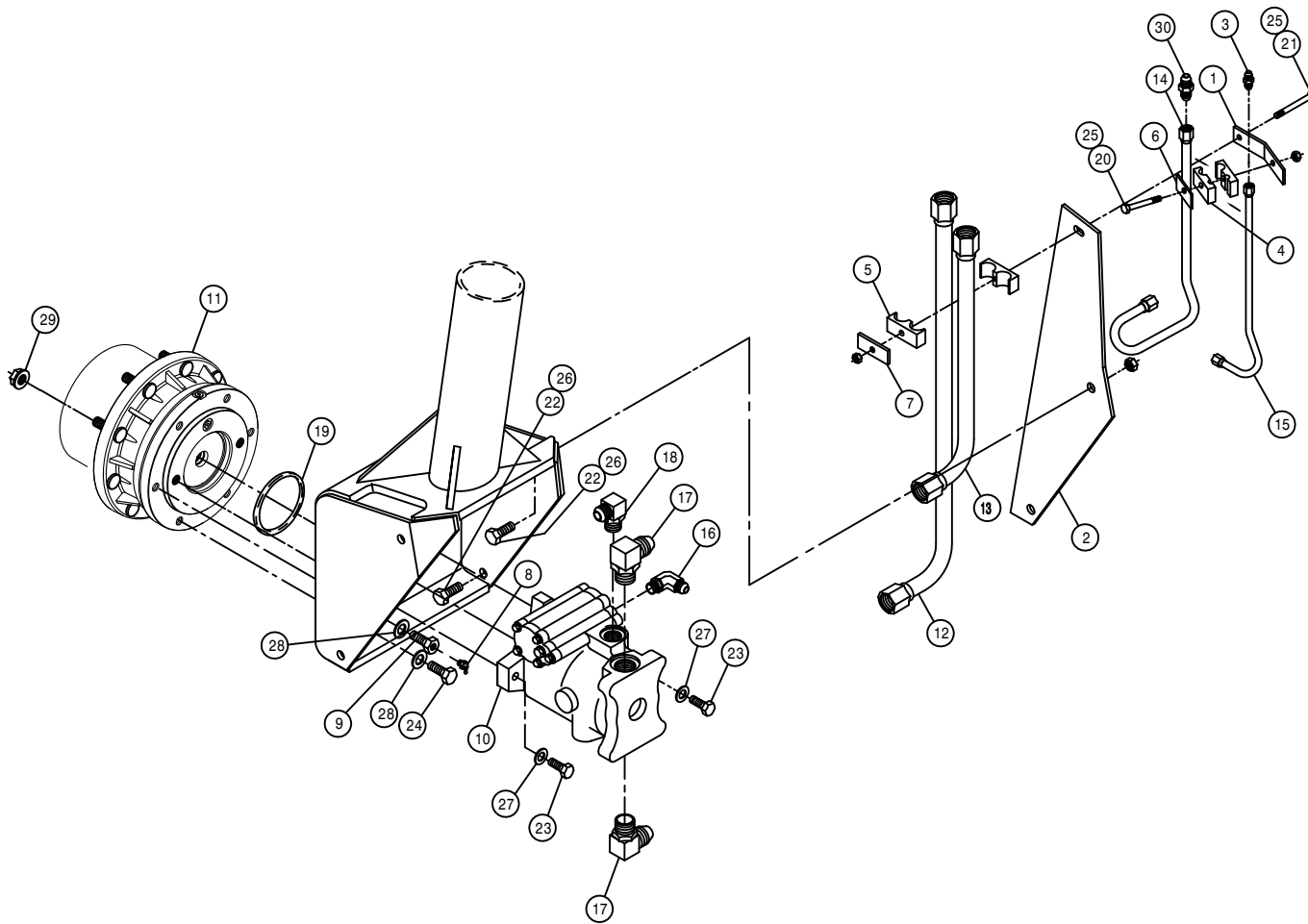

LEFT FRONT LEG ASSEMBLY

DET.	QTY	PART NO.	DESCRIPTION
1	1	358926	FRT LEG HYD TUBE BRKT, 2100 98
2	1	359243	HYD TUBE MTG PLT, 284TXP 03
3	1	619010	9/16MJIC UNION
4	1	470272	TUBE CLAMP BODY, .375-.500
5	1	470275	TUBE CLAMP BODY, 1.000-1.000
6	1	470277	CLAMP WELD PLATE, SNGL, 2.15LG
7	1	470278	CLAMP WELD PLATE, SNGL, 2.75LG
8	1	471023	GREASE ZERK 1/4-28 X 45
9	1	610013	ZERK BOLT, 5/8 X 1 1/4 TORQ HUB
10	1	610637	SUND HYD MOTOR, M46-4019
11	1	610844	TORQ HUB, 7HBX 29:1
12	1	615708	LWR HYD TUBE ASSY,LEG 2100 98
13	1	615808	UPR HYD TUBE ASSY,LEG 2100 03
14	1	615809	LF/RR HYD DRN TUBE ASSY2100 03
15	1	615713	LF/RR HYD CTRL TUBE ASSY210098
16	1	618119	9/16MJIC-90-9/16MOR LBO
17	2	618178	1 5/16MJIC-90-1 5/16MOR LBO
18	1	618474	3/4MJIC-90-1 1/16MOR LBO
19	1	870045	O-RING 4 1/8 OD X 4 ID
20	1	900068	5/16UNC X 1 3/4 HEX BOLT
21	1	900070	5/16UNC X 2 1/2 BOLT
22	2	900264	1/2UNC X 1 1/4 HEX BOLT
23	2	900266P	1/2UNC X 1 3/4 HEX BOLT
24	5	900332P	5/8UNC X 1 1/4 HEX BOLT ZINC
25	2	914002	5/16UNC HEX STOVER NUT
26	2	470360	1/2UNC HEX FLANGE LOCK NUT
27	2	920504P	1/2 LOCK WASHER
28	6	920505P	5/8 LOCK WASHER
29	9	470140	5/8UNF HEX SMTH FLANGE NUT PLT
30	1	618314	3/4MJIC UNION

RH REAR LEG ASSEMBLY

DET.	QTY	PART NO.	DESCRIPTION
1	2	121029	JOURNAL BRG, 1.00 ID X 1.00 LG
2	2	121105	LEG TOWER SLIDE BEARING, ORKOT
3	1	125050	BRG CONE, 1.00 ID W/FACE SEAL
4	1	125051	BRG CUP FOR 125050
5	1	125052	BRG CONE, 2.687 ID W/FACE SEAL
6	1	125053	BRG CUP FOR 125052
7	2	311058	RUBBER SPRING
8	1	311066	AIRIDE SPRING, 9.75 BASE
9	1	358832	AIRIDE SPRING CTRL VALVE 98
10	1	342654	NYL HOSE SLEEVE, 3.66ID X 24.00
11	1	483019	7/8" INTERNAL TOOTH LOCK WASHER
12	1	358564	FRT LEG LWR NYL SLEEVE 280 89
13	1	358565	FRT LEG UPR NYL SLEEVE 280 89
14	4	358927	LWR BRG KPR, LEG 98
15	1	359289	LH LEG AIR VALVE MT, STS 04
16	1	342800	NYL HOSE SLEEVE, 3.34ID X 100
17	1	359052	AIR BAG TOWER TOP MT WLD
18	1	359082	STEERING ARM BRG SPACER
19	1	359095	LEG HEIGHT CTRL LINKAGE, STS12
20	1	359440	UPPER TRUNNION MT WLD ,DTS 8T
21	1	359226	RH AIR BAG LWR PLT WLD, 284TXP
22	2	359230	NITRO TOWER SHAFT WLD, 284TXP03
23	2	359232	TOWER SPACER WLD, 284TXP 03
24	1	359235	RH STEERING ARM WLD, 284TXP 03
25	1	359240	REAR TIE ROD WLD, 284TXP 03
26	1	359244	INNER LEG WLD, 284TXP 03
27	1	359257	RH REAR OUTER LEG WLD, 284TXP03
28	2	470117	COTTER PIN 3/16 1 3/4 SQ CUT
29	1	470265	KEY, .250 X .375 X 1.88 LG
30	2	471005	1/4 28 X 1/2 GREASE ZERK
31	2	471023	GREASE ZERK 1/4-28 X 45
32	1	472322	7/8-14 UNF HEX JAM NUT
33	1	473983	ROD END, .875 BORE, .875-14 RH FEM
34	2	711036	1/8MNPT-1/4 NYL TUBE FTG
35	1	711040	1/4MNPT-90-1/4 NYL TUBE LBO
36	2	900002	1/4UNC X 3/4 HEX BOLT
37	4	900265	1/2UNC X 1 1/2 HEX BOLT
38	16	900266	1/2UNC X 1 3/4 HEX BOLT
39	4	900269	1/2UNC X 2 3/4 HEX BOLT
40	2	900352P	5/8UNC X 2 1/4 HEX BOLT
41	4	900836	5/8UNF X 3 1/4 HEX BOLT GR8
42	1	910008	1/2UNC HEX NUT
43	1	910013	3/4UNF HEX NUT
44	1	910021	1"-14 SLOT JAM NUT
45	2	914000	1/4UNC HEX STOVER NUT
46	20	470360	1/2UNC HEX FLANGE LOCK NUT
47	2	914010P	5/8UNC HEX STOVER NUT
48	14	914811	5/8UNF HEX NUT GR8
49	1	920008	1" SAE FLAT WASHER
50	8	920501	5/16 LOCK WASHER
51	8	900064	5/16UNC X 3/4 HEX BOLT
52	5	920504	1/2 LOCK WASHER
53	1	920506	3/4 LOCK WASHER
54	1	359239	STEERING ARM BOLT, 284TXP 03
55	1	825013	7/8-14UNF SLOTTED HEX NUT
56	3	900837	5/8UNF X 3 1/2 HEX BOLT GR8
57	1	358759	LEG MT V-PLT WLD, 284T 94
58	1	601416	HOSE, 1/4 X 122 AIR
59	1	601473	HOSE, 1/4 X 22 AIR

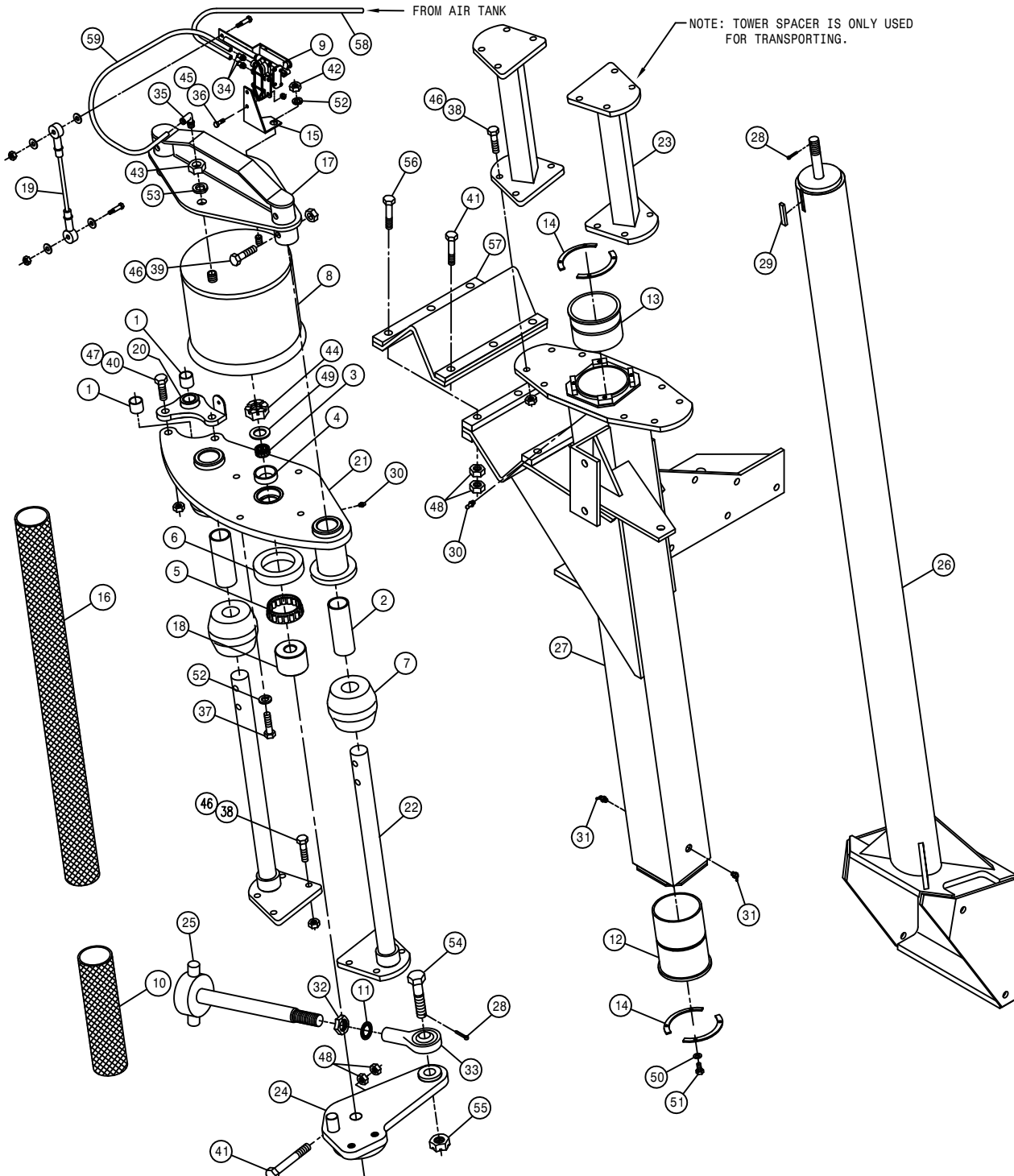

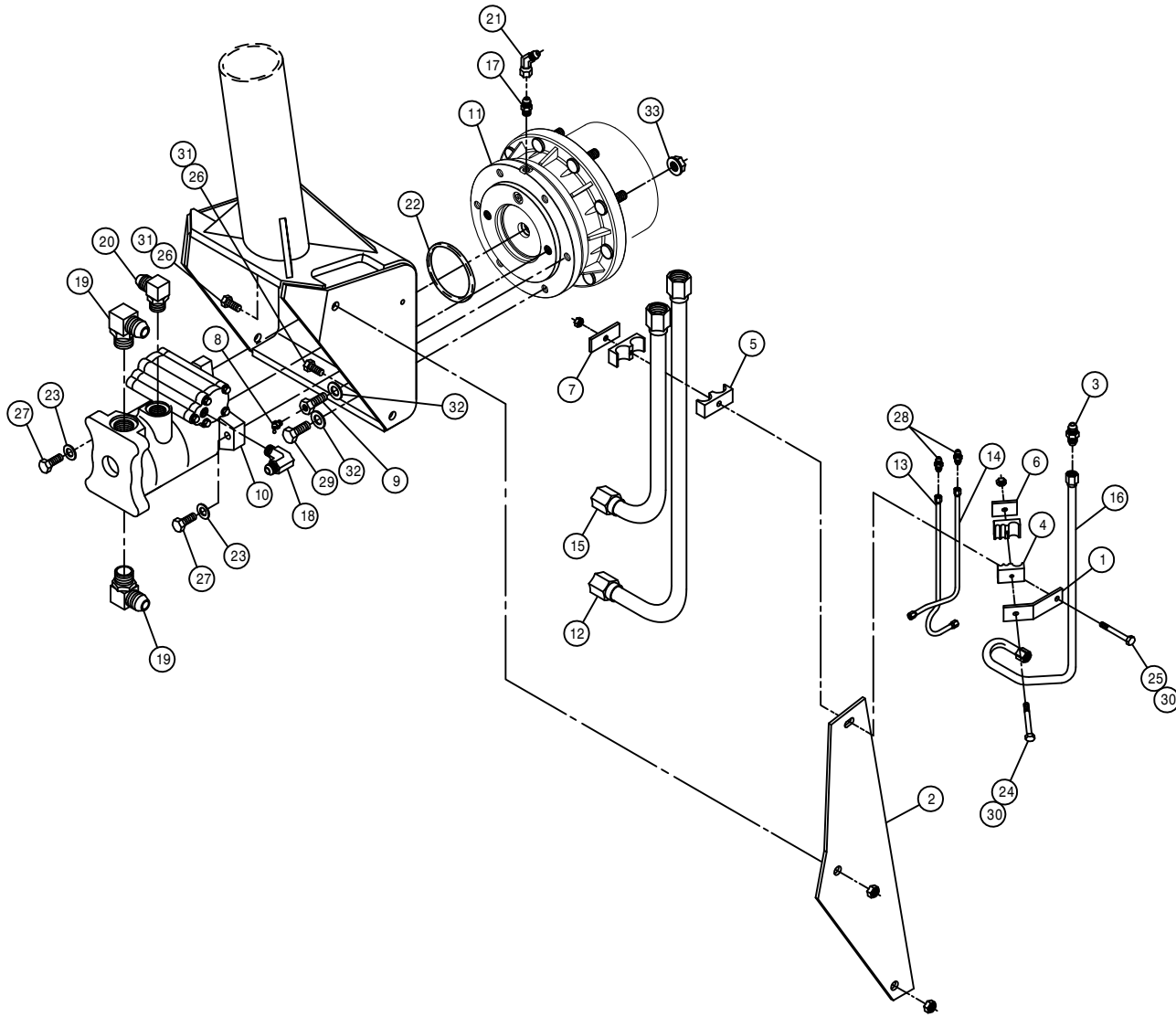

RH REAR LEG ASSEMBLY

DET.	QTY	PART NO.	DESCRIPTION
1	1	358934	REAR LEG HYD TUBE BRKT,2100 98
2	1	359243	HYD TUBE MTG PLT, 284TXP 03
3	1	618314	3/4MJIC UNION
4	1	470273	TUBE CLAMP BODY, .375-.375-.500
5	1	470275	TUBE CLAMP BODY, 1.000-1.000
6	1	470277	CLAMP WELD PLATE, SNGL, 2.15LG
7	1	470278	CLAMP WELD PLATE, SNGL, 2.75LG
8	1	471023	GREASE ZERK 1/4-28 X 45
9	1	610013	ZERK BOLT, 5/8 X 1 1/4 TORQ HUB
10	1	608000	SAUER HYD MOTOR, M46-4024
11	1	610847	TORQ HUB, 7HBA 29:1 W/BRAKE
12	1	615708	LWR HYD TUBE ASSY,LEG 2100 98
13	1	615713	LF/RR HYD CTRL TUBE ASSY210098
14	1	615815	RH HYD BRAKE TUBE ASSY,2101 04
15	1	615808	UPR HYD TUBE ASSY,LEG 2100 03
16	1	615809	LF/RR HYD DRN TUBE ASSY2100 03
17	1	618304	9/16MJIC-7/16MOR ADPTR
18	1	618119	9/16MJIC-90-9/16MOR LBO
19	2	618178	1 5/16MJIC-90-1 5/16MOR LBO
20	1	618474	3/4MJIC-90-1 1/16MOR LBO
21	1	618634	9/16MJIC-45-9/16FJIC SWIV LBO
22	1	870045	O-RING 4 1/8 OD X 4 ID
23	2	920504P	1/2 LOCK WASHER
24	1	900068	5/16UNC X 1 3/4 HEX BOLT
25	1	900070	5/16UNC X 2 1/2 BOLT
26	2	900264	1/2UNC X 1 1/4 HEX BOLT
27	2	900266P	1/2UNC X 1 3/4 HEX BOLT
28	2	619010	9/16MJIC UNION
29	5	900332P	5/8UNC X 1 1/4 HEX BOLT
30	2	914002	5/16UNC HEX STOVER NUT
31	2	470360	1/2UNC HEX FLANGE LOCK NUT
32	6	920505P	5/8 LOCK WASHER
33	9	470140	5/8UNF HEX SMTH FLANGE NUT PLT

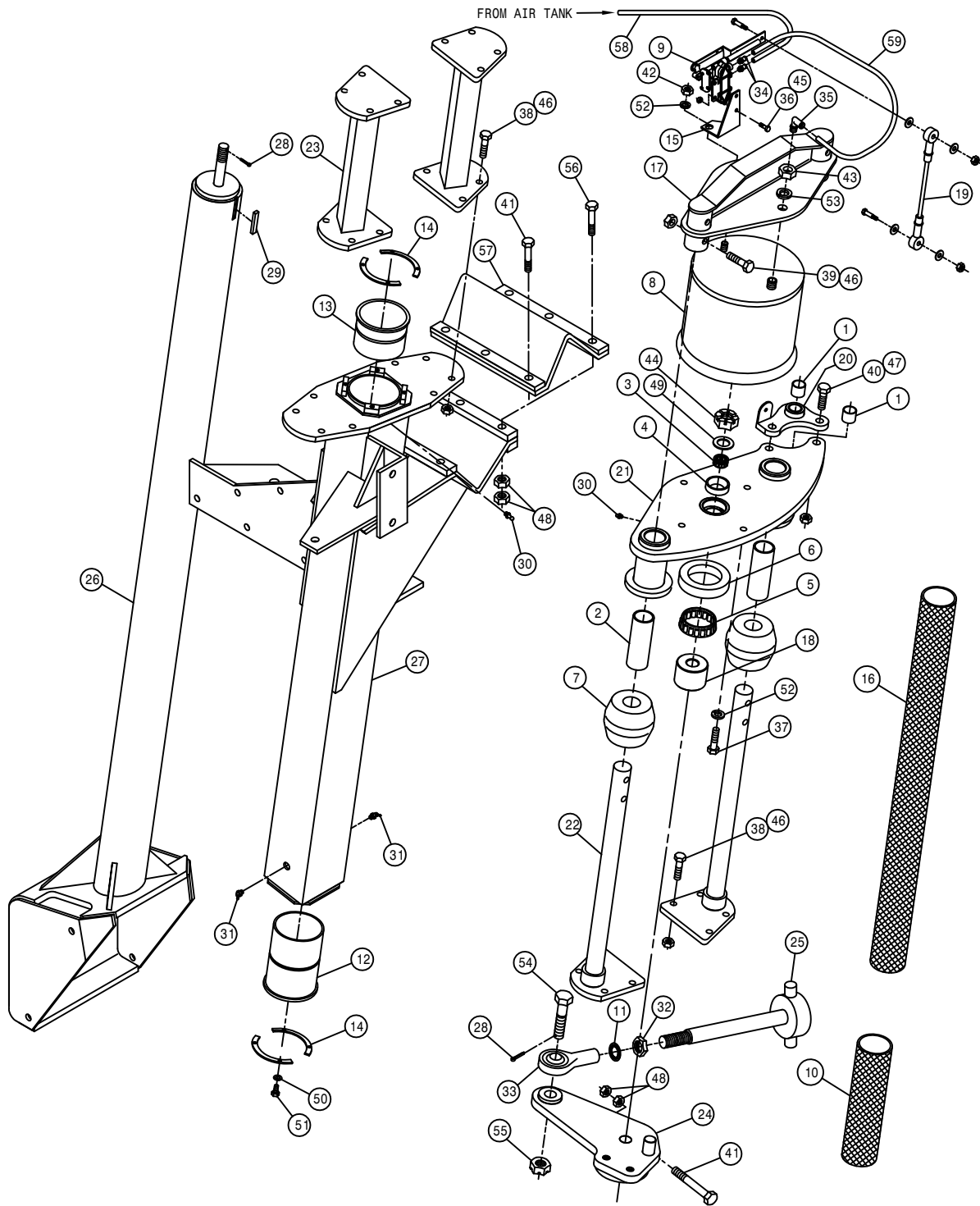

LEFT REAR LEG ASSEMBLY

DET.	QTY	PART NO.	DESCRIPTION
1	2	121029	JOURNAL BRG, 1.00 ID X 1.00 LG
2	2	121105	LEG TOWER SLIDE BEARING, ORKOT
3	1	125050	BRG CONE, 1.00 ID W/FACE SEAL
4	1	125051	BRG CUP FOR 125050
5	1	125052	BRG CONE, 2.687 ID W/FACE SEAL
6	1	125053	BRG CUP FOR 125052
7	2	311058	RUBBER SPRING
8	1	311066	AIRIDE SPRING, 9.75 BASE
9	1	358832	AIRIDE SPRING CTRL VALVE 98
10	1	342654	NYL HOSE SLEEVE, 3.66ID X 24.00
11	1	483019	7/8" INTERNAL TOOTH LOCK WASHER
12	1	358564	FRT LEG LWR NYL SLEEVE 280 89
13	1	358565	FRT LEG UPR NYL SLEEVE 280 89
14	4	358927	LWR BRG KPR, LEG 98
15	1	359288	RH LEG AIR VALVE MT, STS 04
16	1	342800	NYL HOSE SLEEVE, 3.34ID X 100
17	1	359052	AIR BAG TOWER TOP MT WLD
18	1	359082	STEERING ARM BRG SPACER
19	1	359095	LEG HEIGHT CTRL LINKAGE, STS12
20	1	359441	UPPER TRUNNION MT WLD, DTS 8T
21	1	359227	LH AIR BAG LWR PLT WLD, 284TXP
22	2	359230	NITRO TOWER SHAFT WLD, 284TXP03
23	2	359232	TOWER SPACER WLD, 284TXP 03
24	1	359236	LH STEERING ARM WLD, 284TXP 03
25	1	359240	REAR TIE ROD WLD, 284TXP 03
26	1	359244	INNER LEG WLD, 284TXP 03
27	1	359258	LH REAR OUTER LEG WLD, 284TXP03
28	2	470117	COTTER PIN 3/16 1 3/4 SQ CUT
29	1	470265	KEY, .250 X .375 X 1.88 LG
30	2	471005	1/4 28 X 1/2 GREASE ZERK
31	2	471023	GREASE ZERK 1/4-28 X 45
32	1	472322	7/8-14 UNF HEX JAM NUT
33	1	473983	ROD END .875 BORE .875-14 RH FEM
34	2	711036	1/8MNPT-1/4 NYL TUBE FTG
35	1	711040	1/4MNPT-90-1/4 NYL TUBE LBO
36	2	900002	1/4UNC X 3/4 HEX BOLT
37	4	900265	1/2UNC X 1 1/2 HEX BOLT
38	16	900266	1/2UNC X 1 3/4 HEX BOLT
39	4	900269	1/2UNC X 2 3/4 HEX BOLT
40	2	900352P	5/8UNC X 2 1/4 HEX BOLT
41	4	900836	5/8UNF X 3 1/4 HEX BOLT GR8
42	1	910008	1/2UNC HEX NUT
43	1	910013	3/4UNF HEX NUT
44	1	910021	1"-14 SLOT JAM NUT
45	2	914000	1/4UNC HEX STOVER NUT
46	20	470360	1/2UNC HEX FLANGE LOCK NUT
47	2	914010P	5/8UNC HEX STOVER NUT
48	14	914811	5/8UNF HEX NUT GR8
49	1	920008	1" SAE FLAT WASHER
50	8	920501	5/16 LOCK WASHER
51	8	900064	5/16UNC X 3/4 HEX BOLT
52	5	920504	1/2 LOCK WASHER
53	1	920506	3/4 LOCK WASHER
54	1	359239	STEERING ARM BOLT, 284TXP 03
55	1	825013	7/8-14UNF SLOTTED HEX NUT
56	3	900837	5/8UNF X 3 1/2 HEX BOLT GR8
57	1	358759	LEG MT V-PLT WLD, 284T 94
58	1	601416	HOSE, 1/4 X 122 AIR
59	1	601473	HOSE, 1/4 X 22 AIR



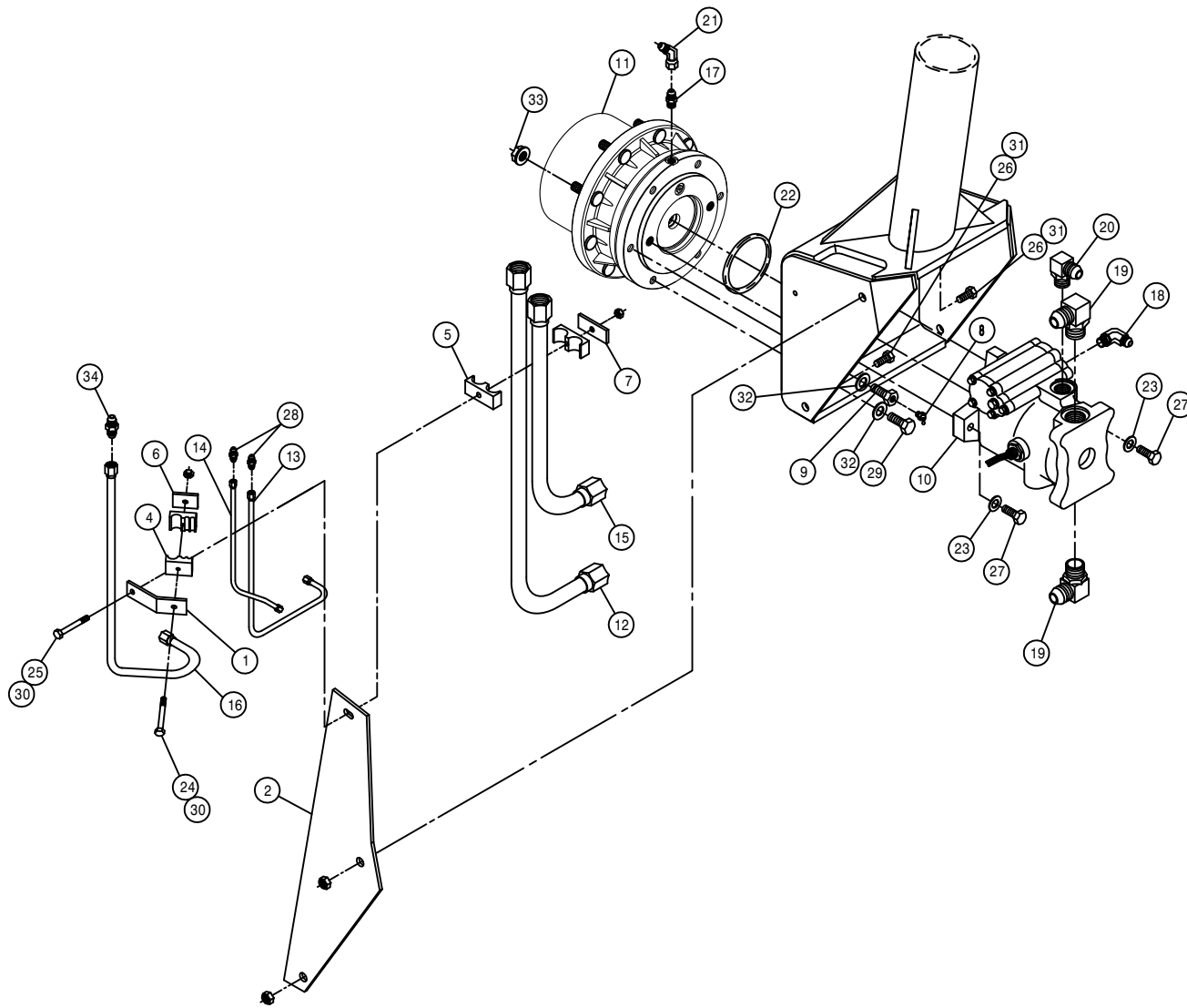

LEFT REAR LEG ASSEMBLY

DET.	QTY	PART NO.	DESCRIPTION
1	1	358934	REAR LEG HYD TUBE BRKT,2100 98
2	1	359243	HYD TUBE MTG PLT, 284TXP 03
3	1	610625	SENSOR,WHL MOTOR, KPPG16008
4	1	470273	TUBE CLAMP BODY, .375-.375-.500
5	1	470275	TUBE CLAMP BODY,1.000-1.000
6	1	470277	CLAMP WELD PLATE, SNGL, 2.15LG
7	1	470278	CLAMP WELD PLATE, SNGL, 2.75LG
8	1	471023	GREASE ZERK 1/4-28 X 45
9	1	610013	ZERK BOLT, 5/8 X 1 1/4, TORQ HUB
10	1	608003	SAUER WHL MOTOR,M46-4194 W/SEN
11	1	610847	TORQ HUB, 7HBA29:1 W/BRAKE
12	1	615708	LWR HYD TUBE ASSY,LEG 2100 98
13	1	615712	RF/LR HYD CTRL TUBE ASSY210098
14	1	615814	LH HYD BRAKE TUBE ASSY,2101 04
15	1	615709	UPR HYD TUBE ASSY,LEG 2100 98
16	1	615710	RF/LR HYD DRN TUBE ASSY2100 98
17	1	618304	9/16MJIC-7/16MOR ADPTR
18	1	618119	9/16MJIC-90-9/16MOR LBO
19	2	618178	1 5/16MJIC-90-1 5/16MOR LBO
20	1	618474	3/4MJIC-90-1 1/16MOR LBO
21	1	618634	9/16MJIC-45-9/16FJIC SWIV. LBO
22	1	870045	O-RING 4 1/8 OD X 4 ID
23	2	920504P	1/2 LOCK WASHER
24	1	900068	5/16UNC X 1 3/4 HEX BOLT
25	1	900070	5/16UNC X 2 1/2 BOLT
26	2	900264	1/2UNC X 1 1/4 HEX BOLT
27	2	900266P	1/2UNC X 1 3/4 HEX BOLT
28	2	619010	9/16MJIC UNION
29	5	900332P	5/8UNC X 1 1/4 HEX BOLT
30	2	914002	5/16UNC HEX STOVER NUT
31	2	470360	1/2UNC HEX FLANGE LOCK NUT
32	6	920505P	5/8 LOCK WASHER
33	9	470140	5/8UNF HEX SMTH FLANGE NUT PLT
34	1	618314	3/4MJIC UNION

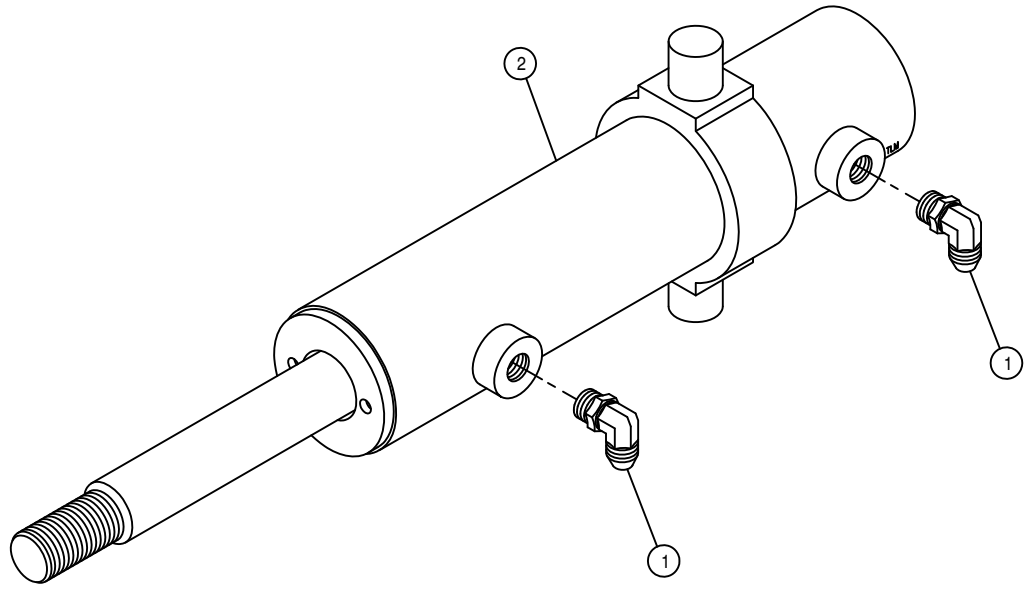

STEERING CYLINDER ASSEMBLY

DET.	QTY	PART NO.	DESCRIPTION	
	1	2	618119	9/16MJIC-90-9/16MOR LBO
	2	1	621512	STEERING CYL ASSY, 2.00 X 6.28
	NS	1	621513	REPAIR KIT, HYD CYL, STRG 621512

NOTE: 1. 621007 - STEERING CYLINDER ASSEMBLY WITH FITTINGS

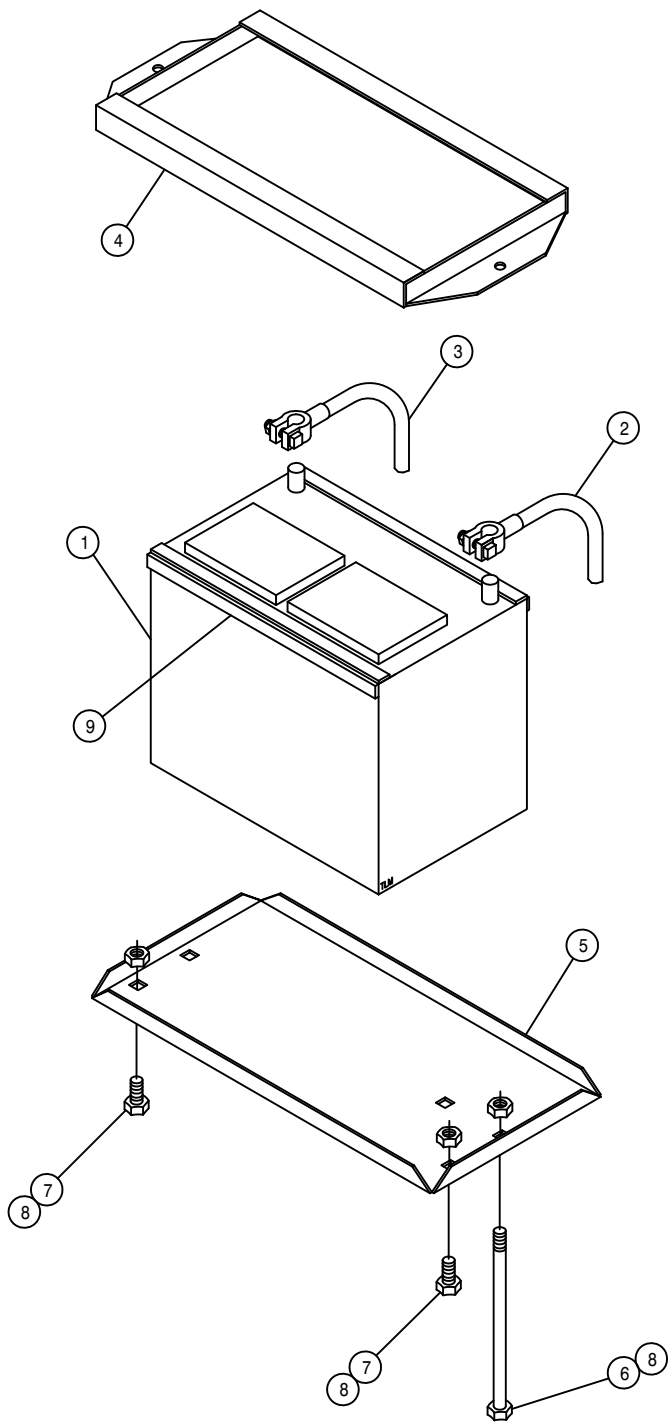

#### BATTERY BOX ASSEMBLY

DET. QTY PART NO. DESCRIPTION

1	1	291122	BATTERY, 12V 950CCA, SAE POST
2	1	291128	BATTERY CABLE 48 IN
3	1	291530	BATTERY GROUND CABLE, 23"
4	1	341322	BATTERY HOLD DOWN WLD 1981
5	1	361149	BATTERY BOX 8300-8400 1981
6	2	901150	3/8UNC X 9" CARR BOLT
7	2	900129	3/8UNC X 1" HEX BOLT
8	4	914004	3/8UNC HEX STOVER NUT
9	4	193022	STICKERTITE 1/4 X 3/4

CAB ASSEMBLY

DET. QTY PART NO. DESCRIPTION

1	1	290107	GROUND CABLE, 8" X 4GA .406LUGS
2	4	311051	RUBBER MOUNT, RB3-350
3	4	311052	SNUBBING WASHER FOR 311051
4	24	193037	STICKERTITE 1/8 X 3/4
5	42	193044	WINDOW WEATHERSTRIP
6	42	193045	LOCK STRIP FOR 193044
7	1	290003	WINDSHIELD WASHER NOZZLE KIT
8	1	291569	3/8 X 6" HEAT SHRINK TUBE
9	1	200019	.25 SCH 40BP X 1.00 LG C/L
10	1	358886	AIR BAG MT LOCK COLLAR BUSH 98
11	1	290412	DIMMER SWITCH
12	1	290417	18" WIPER BLADE
13	4	900343	5/8UNC X 4 1/2 HEX BOLT
14	1	343206	CAB WELDMT, 284XP 2002
15	1	342146	KICK PANEL WLD, 284 CAB 94
16	1	342150	CAB ROOF WLD, 284 94
17	1	342180	HEADLINER KPR ANGLE, 284CAB 94
18	2	470067	GROMMET, .250ID .125GW .375GD
19	2	470070	GROMMET, .375ID .062GW .500GD
20	4	914010	5/8UNC HEX STOVER NUT
21	1	470229	IDENTIFICATION TIE, WHITE
22	6	470100	3/8 INT TOOTH LOCK WASHER
23	13	470121	1/4UNC HEX FLANGE LOCK NUT
24	10	470122	1/4UNC X 1/2 FLANGE HEX BOLT
25	12	470212	1/4 BONDED SEALING WASH, SS
26	16	470218	1/4UNC NUT J-TYPE CAGE CLIP
27	1	470222	GRAB HANDLE, BLACK MOULDED
28	12	472349	1/4 X 3/4 20THD-IN TEK TYPE
29	6	473779	10MM-1.50 HEX NUT
30	2	473910	1/4 X 1 1/2 PHIL HD SHT MTL S
31	2	650524	OUTSIDE MIRROR W/MTG BRKT
32	1	658008	WINDSHIELD WIPER MOTOR
33	1	658013	WIPER ARM
34	1	658014	FRONT CAB GLASS 94
35	1	658015	FRONT SIDE CAB/DOOR GLASS 94
36	2	658016	REAR SIDE CAB GLASS 94
37	1	658017	REAR CAB GLASS 94
38	8	900002	1/4UNC X 3/4 HEX BOLT
39	1	900005	1/4UNC X 1 1/2 HEX BOLT
40	6	291603	HALOGEN WORKLAMP, SIDE MT 12V
41	2	903883	10-32 X 1/2 SLT RDHD MACH SCR
42	2	472235	10-32 X 3/4 PHIL HD MACH SCR
43	4	470175	10-32 HEX FLANGE LOCK NUT
44	14	195913	HOSE 7/64" WINDSHIELD WASHER
45	1	914000	1/4UNC HEX STOVER NUT
46	1	914004	3/8UNC HEX STOVER NUT
47	2	342333	NYL HOSE SLEEVE, 2.64ID X 12.00
48	1	629728	FINISH PLUG FOR 2.12 HOLE
49	11	470118	1/4UNC X 3/4 FLANGE HEX BOLT
50	2	659704	FOAM, 2"THK X 2" WIDE X 42"LG
51	2	470487	GROMMET, .312ID .062W .562GD
52	16	470514	1/4 X 1 SEALING WASHER SS

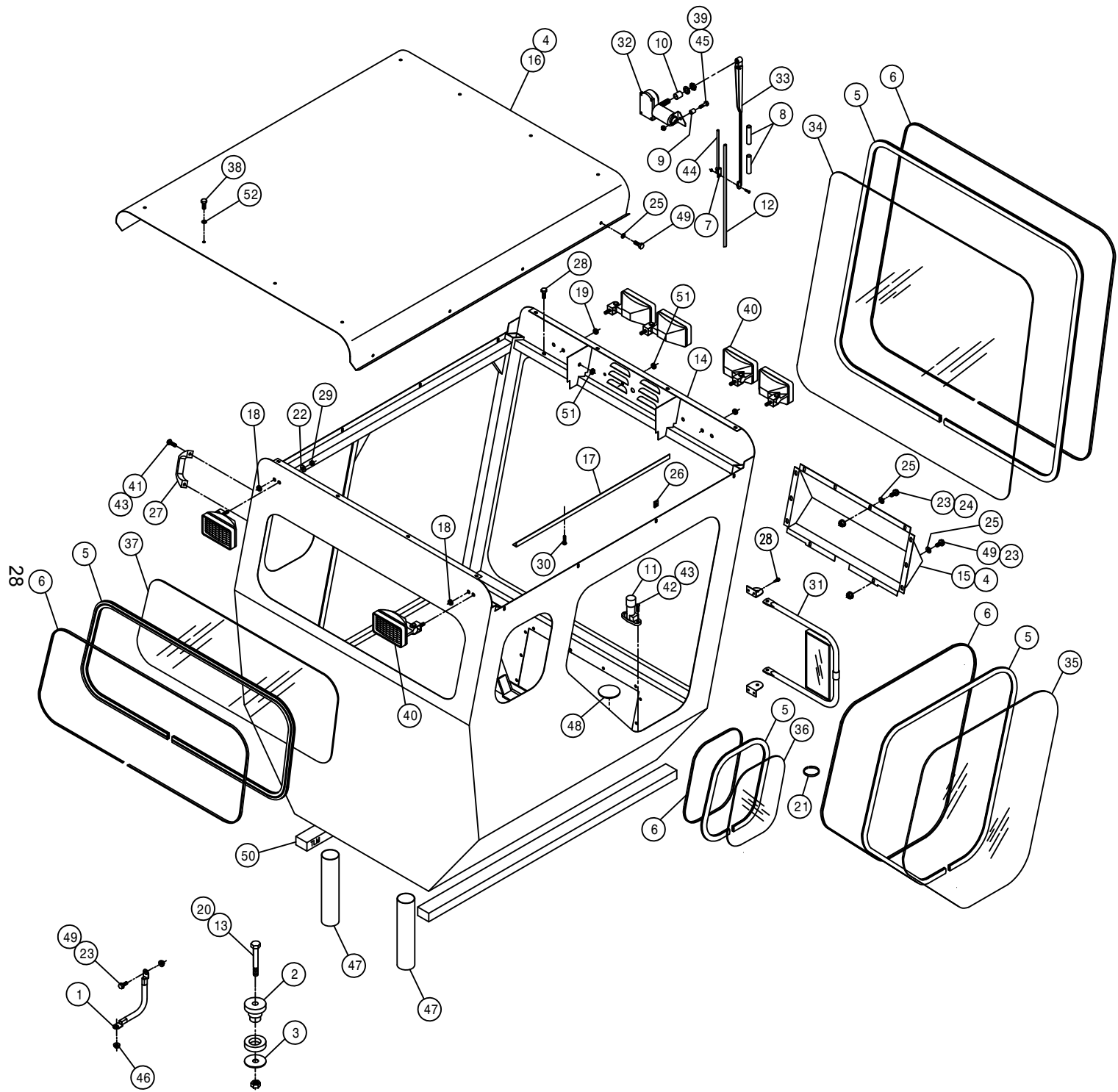

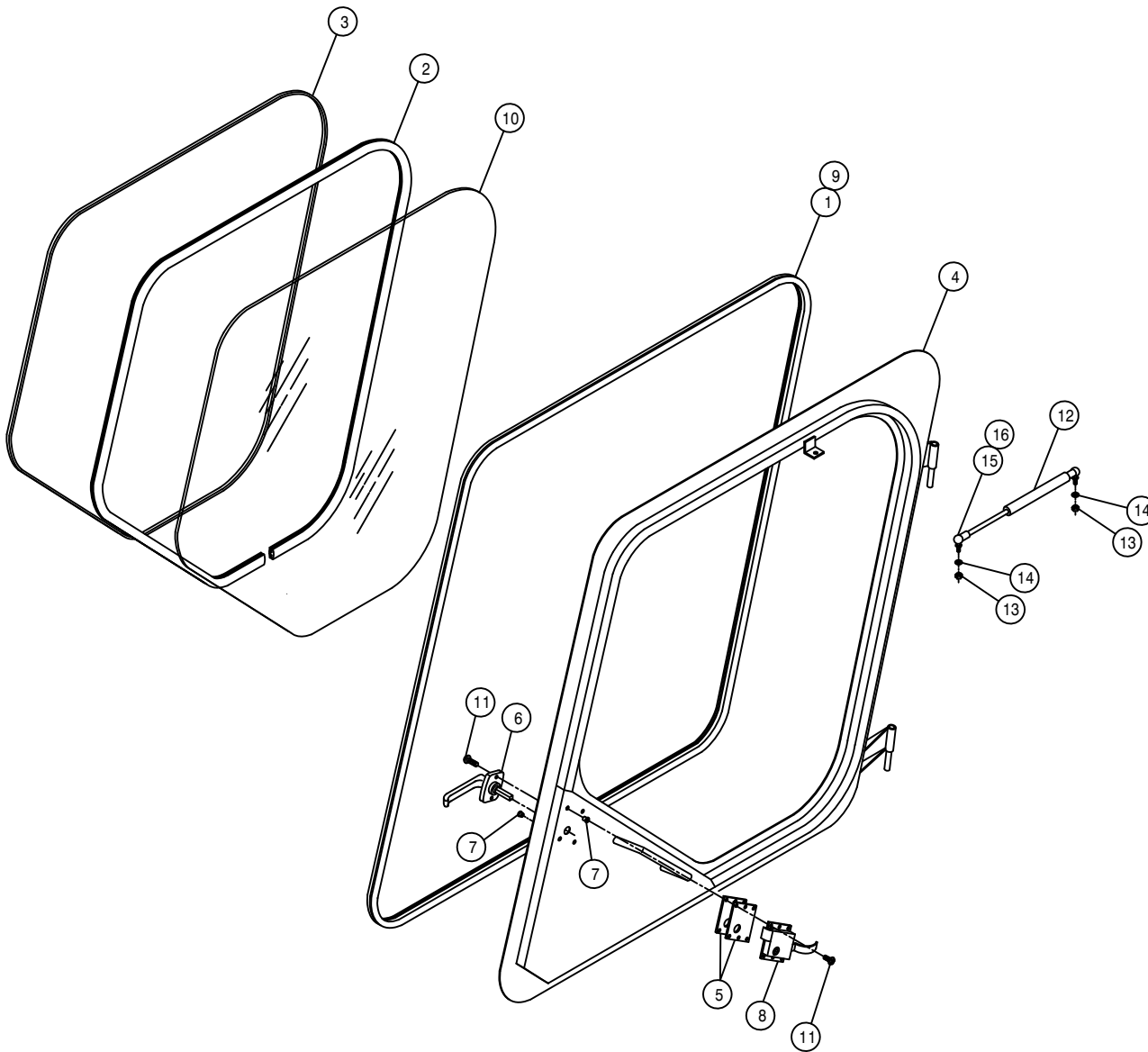

DOOR ASSEMBLY

DET.	QTY	PART NO.	DESCRIPTION
	12	193028	PUSH-ON TRIM SEAL RS-130-FX
	2	193044	WINDOW WEATHERSTRIP
	3	193045	LOCK STRIP FOR 193044
	4	342153	LH DOOR WLD, 284 CAB 94
	5	342163	CAB DOOR LATCH SHIM, .06 94
	6	342217	DOOR HANDLE, 254/284 CAB 94
	7	470165	10-32 NUTSERT .020-.100 ALUM
	8	470219	CAB LOCK, LH #55
	9	485052	POP RIVET 1/8 X 3/8
	10	658015	FRONT SIDE CAB/DOOR GLASS 94
	11	903710	10-32X5/8 PHIL PANHD MACH SCR
	12	470221	GAS SPRING, 60LB 3.5 STROKE
	13	910002	5/16UNC HEX NUT
	14	920501	5/16 LOCK WASHER
	15	470255	BALL STUD,5/16-18 THD X 10MM
	16	470256	SAFTY CLIP, 10MM BALL SOCKET

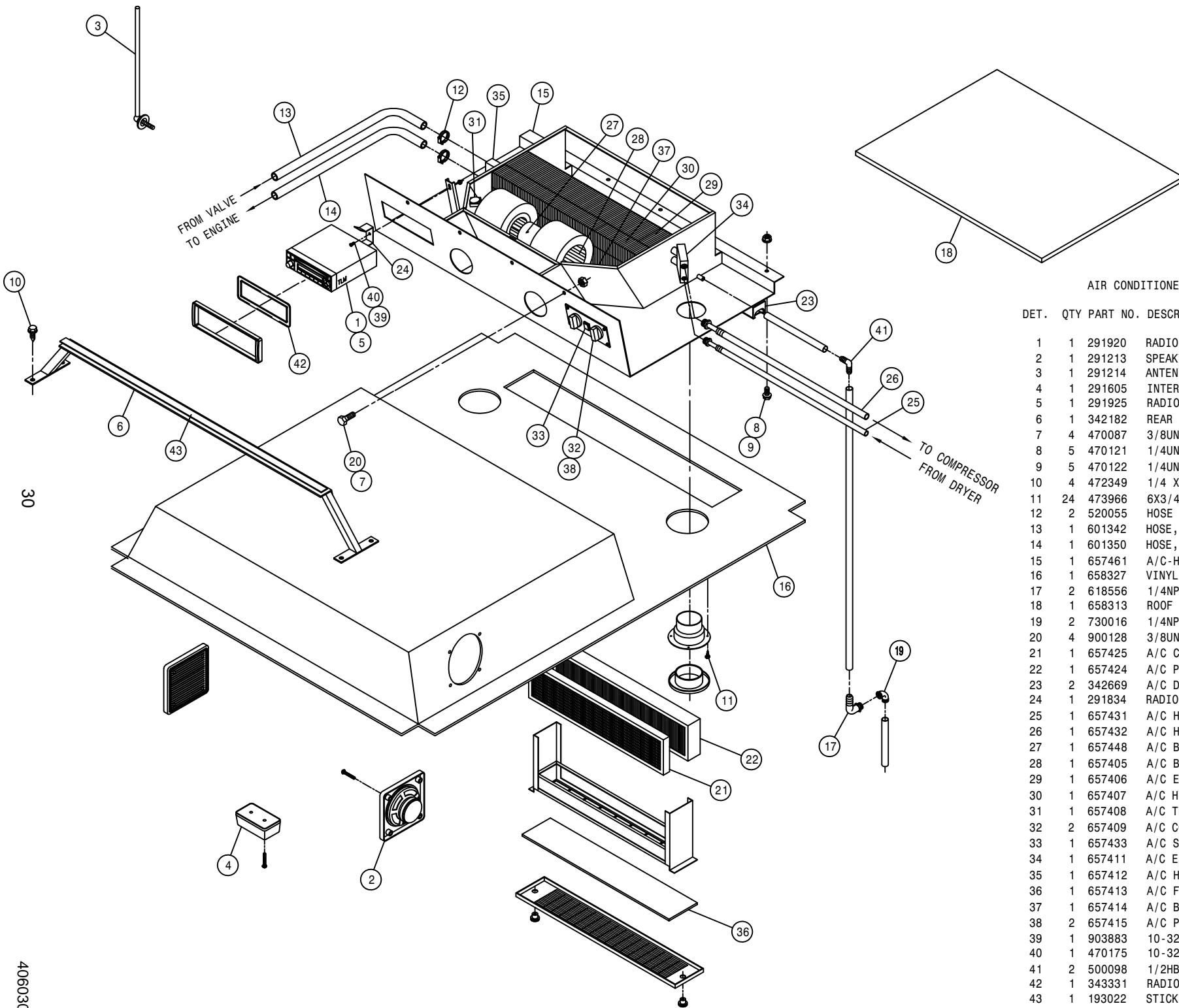

AIR CONDITIONER ASSEMBLY

DET.	QTY	PART NO.	DESCRIPTION
1	1	291920	RADIO CRW200
2	1	291213	SPEAKERS (PAIR)
3	1	291214	ANTENNA
4	1	291605	INTERIOR LIGHT W/SWITCH
5	1	291925	RADIO WIRE HARNESS, DTS 05
6	1	342182	REAR A/C BLOWER MT WLD,CAB 94
7	4	470087	3/8UNC HEX FLANGE LOCK NUT
8	5	470121	1/4UNC HEX FLANGE LOCK NUT
9	5	470122	1/4UNC X 1/2 FLANGE HEX BOLT
10	4	472349	1/4 X 3/4 20THD-IN TEK TYPE
11	24	473966	6X3/4 PHIL FLT HD SHT MTL SCR
12	2	520055	HOSE CLAMP NO 12 STAINLESS
13	1	601342	HOSE, 5/8 X 192 HEATER
14	1	601350	HOSE, 5/8 X 160 HEATER
15	1	657461	A/C-HTR BLOWER SYS, DTS8 05
16	1	658327	VINYL HEAD LINER 99
17	2	618556	1/4NPT-90-1/2 HOSE BARB,POLY
18	1	658313	ROOF SEAL,AIR COND 204,254,284
19	2	730016	1/4NPT ST EL, 90 DEG POLY
20	4	900128	3/8UNC X 3/4 HEX BOLT
21	1	657425	A/C CHARCOAL AIR FILTER
22	1	657424	A/C PAPER AIR FILTER
23	2	342669	A/C DRAIN HOSE KEEPER
24	1	291834	RADIO SUPPORT BRKT
25	1	657431	A/C HOSE ASSY, 5/16 X 173
26	1	657432	A/C HOSE ASSY, 1/2 X 190.
27	1	657448	A/C BLOWER ASSY, 12V KENWAY
28	1	657405	A/C BLOWER WHEEL W/CLIP
29	1	657406	A/C EVAPORATOR COIL
30	1	657407	A/C HEATER COIL
31	1	657408	A/C THERMOSTAT
32	2	657409	A/C CONTROL KNOB
33	1	657433	A/C SWITCH, ROCKER ON-OFF
34	1	657411	A/C EXPANSION VALVE
35	1	657412	A/C HEATER VALVE,4-WAY MTRIZED
36	1	657413	A/C FILTER,RECIRCULATION 30"
37	1	657414	A/C BLOWER DRIVE ASSY
38	2	657415	A/C POTENTIOMETER ASSY
39	1	903883	10-32 X 1/2 SLT RDHD MACH SCR
40	1	470175	10-32 HEX FLANGE LOCK NUT
41	2	500098	1/2HB-90-1/2 HOSE BARB, POLY
42	1	343331	RADIO BEZEL,CAB, BLK PLASIC 05
43	1	193022	STICKERTITE 1/4 X 3/4

CAB FOAM

DET. QTY PART NO. DESCRIPTION

1	1	658301	VINYL POST COVER, RH FRONT	94
2	1	658302	VINYL POST COVER, LH FRONT	94
3	1	658303	VINYL POST COVER, RH REAR	94
4	1	658304	VINYL POST COVER, LH REAR	94
5	1	658305	VINYL SIDE PANEL, RH	94
6	1	658306	VINYL SIDE PANEL, RH UPPER	94
7	1	658307	VINYL SIDE PANEL, RH LOWER	94
8	1	658308	VINYL SIDE PANEL, LH UPPER	94
9	1	658309	VINYL SIDE PANEL, LH LOWER	94
10	1	658310	VINYL FRONT COVER PANEL	94
11	1	658311	VINYL REAR COVER PANEL	94
12	1	658328	FLOORMAT, 284XP CAB	2002
13	2	470225	TRIM CLIP, 11/16 BLK NYL HEAD	

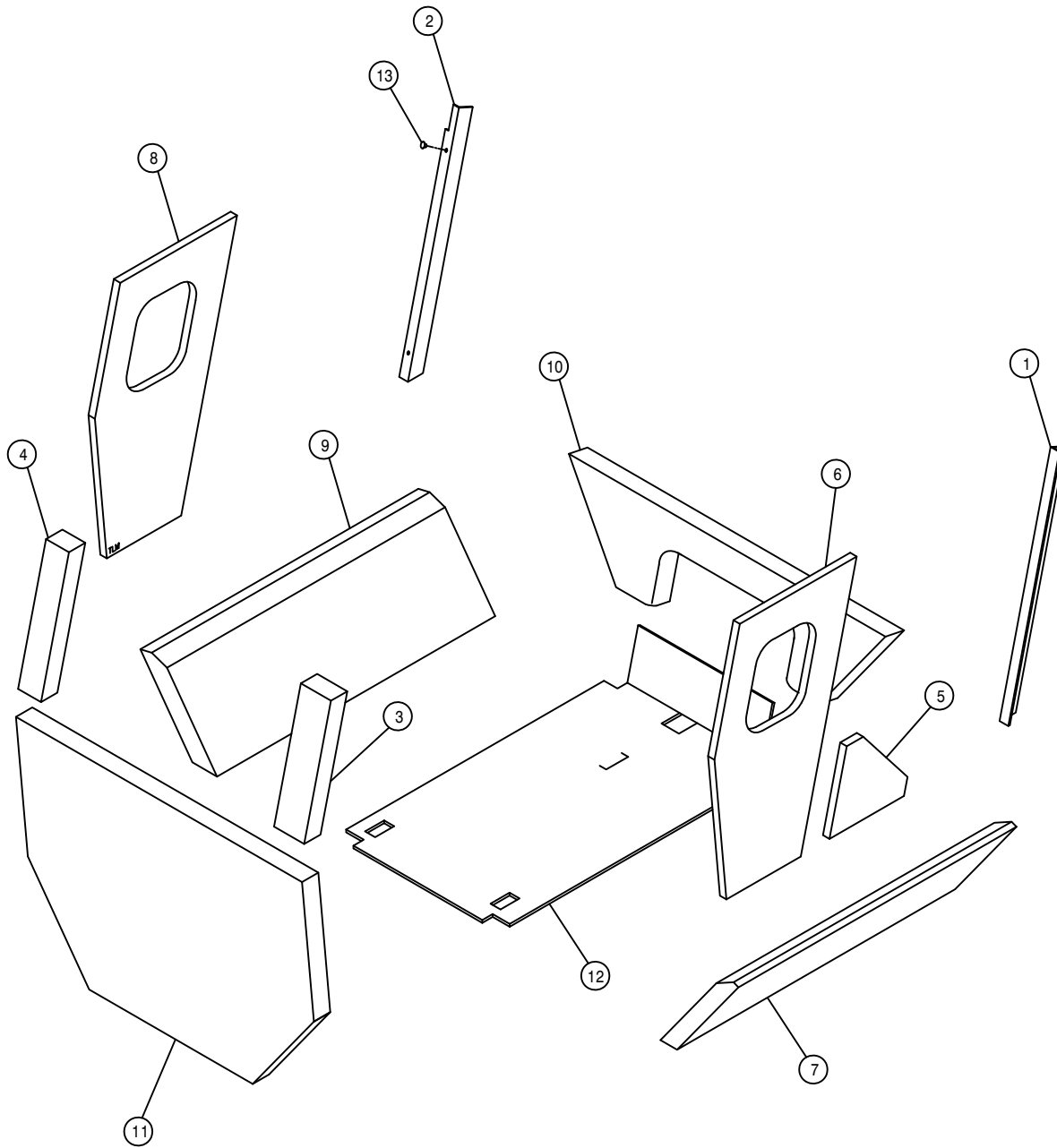

STEERING POST ASSEMBLY

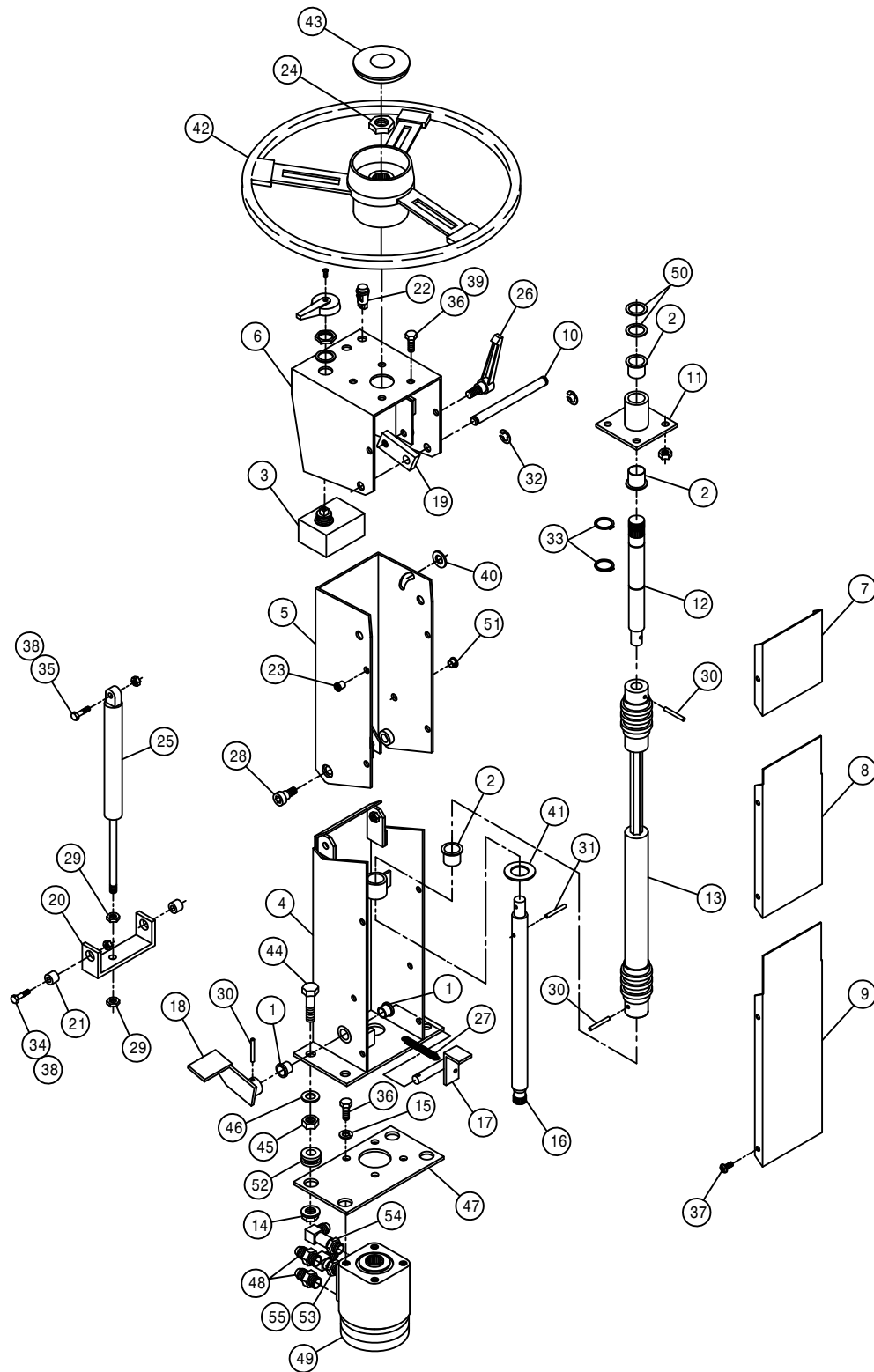

DET. QTY PART NO. DESCRIPTION

1	2	127502	NYLON FLANGE BRG
2	3	127503	NYLINER FLG BRG, .875 ID
3	1	291088	FLASHER / TURN SIGNAL SWITCH
4	1	342450	LWR STRG COLUMN WLD, 2100 98
5	1	342454	UPPER STRG COLUMN WLD, 2100 98
6	1	342461	STRG WHL MT WLD, 2100 98
7	1	342467	UPPER STRG COLUMN COVER,2100 98
8	1	342468	CNTR STRG COLUMN COVER,2100 98
9	1	342469	LWR STRG COLUMN SHLD
10	1	342470	STRG COLUMN PIVOT PIN, 2100 98
11	1	342471	STRG COL BRG HSNGL WLD, 2100 98
12	1	342474	UPPER STEERING SHAFT, 2100 98
13	1	470285	DOUBLE UNIVERSAL JOINT DRIVER
14	4	470345P	1/2UNC HEX SMTH FLNG LOCK NUT
15	4	920502	3/8 LOCK WASHER
16	1	342483	LWR STEERING SHAFT, 2100 98
17	1	342484	FOOT PEDAL PIV PIN WLD,2100 98
18	1	342487	FOOT PEDAL WLD, 2100 98
19	1	342490	STRG PIVOT LOCK, 2100 98
20	1	342491	LWR AIR SHOCK PIVOT, 2100 98
21	2	342492	LWR AIR SHOCK PIV BUSH,2100 98
22	2	390318	INDICATOR LIGHT, RED
23	10	470380	1/4-20 NUTSERT .027-.165 STL
24	1	470157	13/16-20UNEF HEX NUT STRG WHL
25	1	470252	GAS SPRING, LOCKING 0350N
26	1	470257	ADJ HANDLE,3/8-16 STUD, BLACK
27	1	470268	SPRING, EXTENSION, .50 X 1.75
28	2	470283	3/8UNC 1/2 SCKT SHLDR BOLT
29	2	473830	10MM-1.00 HEX JAM NUT
30	3	473928	ROLL PIN, 3/16 X 1
31	1	473936	ROLL PIN, 3/16 X 1 1/4
32	2	629525	RING, RETAINING, .50DIA SHAFT
33	2	629533	SNAP RING, 7/8 EXTRN
34	2	900065	5/16UNC X 1" HEX BOLT
35	1	900067	5/16UNC X 1 1/2 HEX BOLT
36	8	900128	3/8UNC X 3/4 HEX BOLT
37	10	903708	1/4UNC X1/2 PHIL PNHD MACHSCR
38	3	914002	5/16UNC HEX STOVER NUT
39	4	914004	3/8UNC HEX STOVER NUT
40	1	920002	3/8 SAE FLAT WASHER
41	1	920007	7/8 SAE FLAT WASHER
42	1	749294	STEERING WHEEL, VIP 14"
43	1	749295	STRG WHL CAP W/HAGIE EMBLEM
44	4	900267P	1/2UNC X 2" HEX BOLT
45	4	914008N	1/2UNC SMTH FLANGE NUT
46	4	920004	1/2 SAE FLAT WASHER
47	1	343211	STEERING MTR PLT,284XP/2100 02
48	2	618109	9/16MJIC-3/4MOR ADPTR
49	1	749318	STRG MTR,7.3CID,NON-LOAD 1031
50	2	483031	1 3/8 X 7/8 X 18GA MACH WASHER
51	1	470342	SNAP PLUG, BLK NYL, .375 DIA
52	4	470346	GROMMET, .500ID .250GW, .812GD
53	1	618115	9/16MJIC-90-3/4MOR LBO
54	1	618709	9/16MJIC-90-3/4MOR EX LG LBO
55	1	618618	9/16MJIC-90-9/16FJIC SWIV LBO



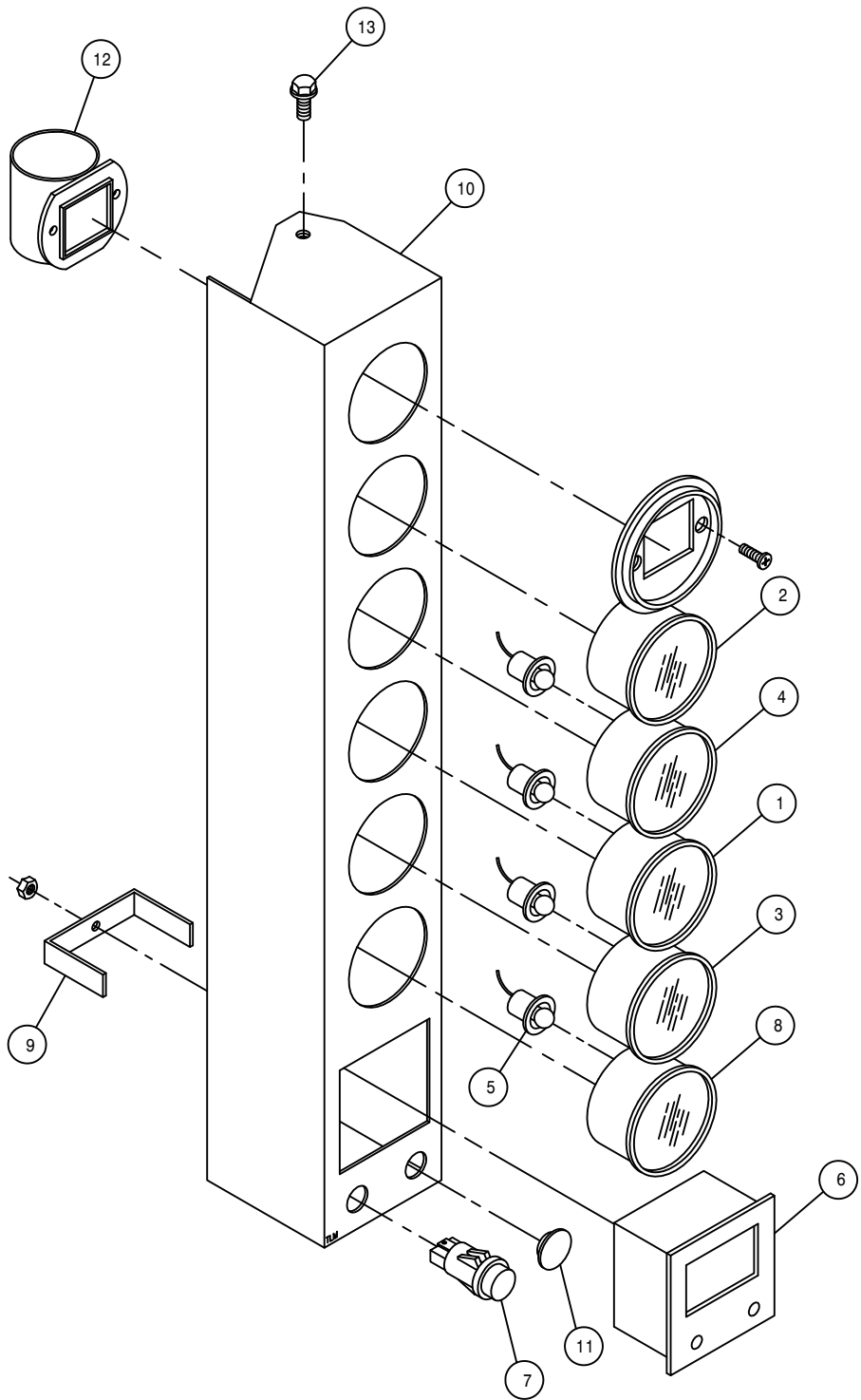

INSTRUMENT PANEL ASSEMBLY

DET. QTY PART NO. DESCRIPTION

1	1	290401	FUEL GAUGE FOR 2.125 DIA HOLE
2	1	291203	HOUR METER, 10/80VDC BLACK BEZ
3	1	291673	OIL PRESS GAUGE, 125PSI
4	1	291611	VOLTMETER, 8V TO 18V DC
5	4	291612	LIGHT KIT FOR 2" GAUGE
6	1	291635	DIGITAL MPH/RPM INDICATOR
7	1	291638	INDICATOR LIGHT, GREEN
8	1	314436	TEMP GA 100-280 DEG LIGHTED
9	1	342068	DIGITAL MPH/RPM IND KEEPER 94
10	1	342186	INSTRU HSNGLD, 284 CAB 94
11	1	658174	RUBBER BUMPER, 1.0000D .500GD
12	1	314901	FILTER MINDER AIR RESTRICT GA
13	2	470122	1/4UNC X 1/2 FLANGE HEX BOLT

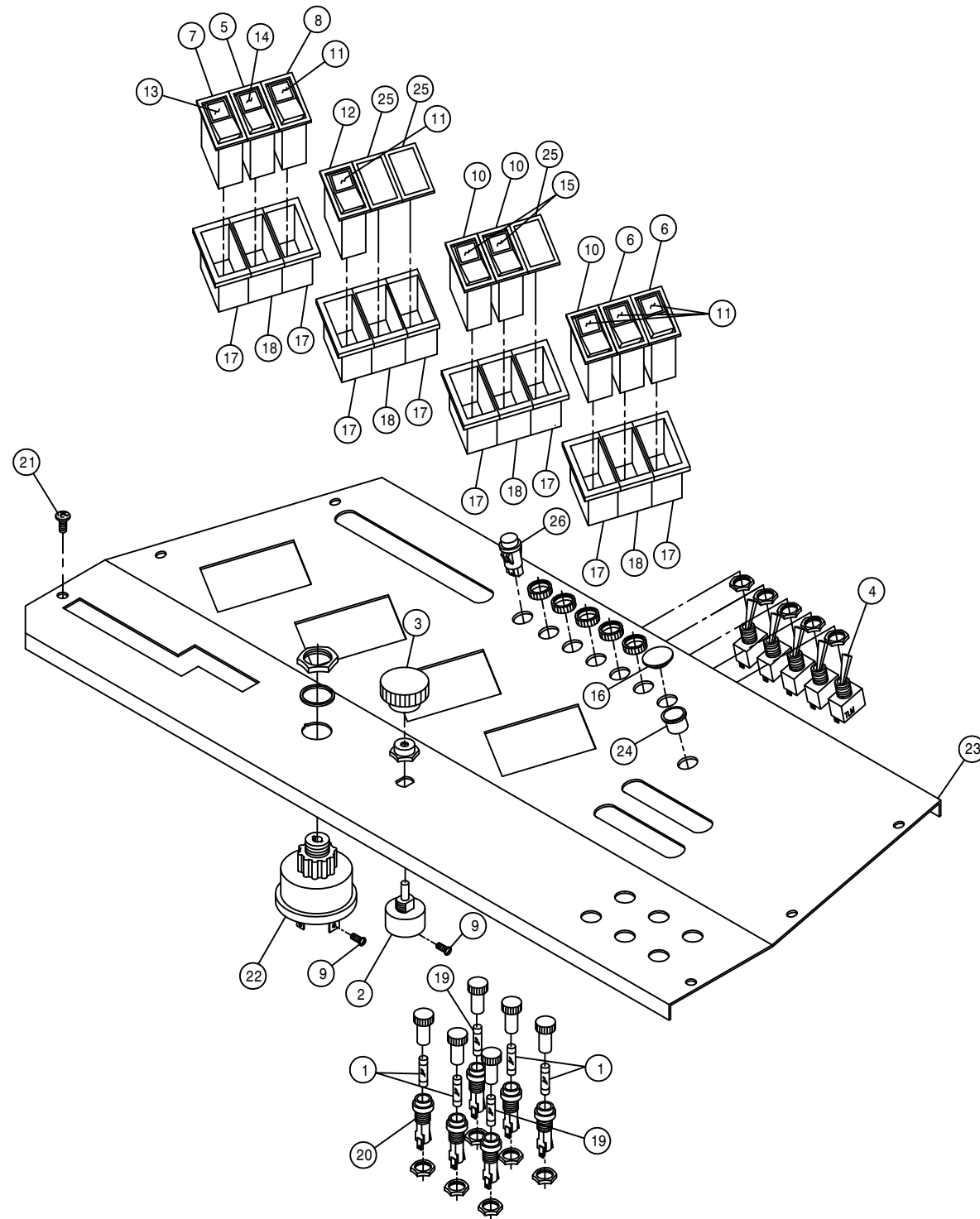

CONSOLE PANEL ASSEMBLY

DET. QTY PART NO. DESCRIPTION

1	4	291602	FUSE 10 AMP
2	1	291606	ROTARY HEADLAMP SWITCH
3	1	291607	SWITCH KNOB FOR 291606
4	5	291608	TOGGLE SWITCH, ON-OFF, UNLIT
5	1	291622	SWITCH, 1P ON/OFF 511-003
6	2	291623	SWITCH, 2P ON/OFF 511-015
7	1	291678	SWITCH, 511-115
8	1	291625	SWITCH, 2P ON/ON 511-108
9	2	903844	8-32 X 1/2 SLT RD HD MACH SCR
10	3	291627	SWITCH, 2P (ON) OFF (ON) 511-058
11	5	291628	LENS, GREEN 596-650
12	1	291671	SWITCH, 2P OFF/ONA/ONAB 511-138
13	1	291630	LENS, WINDSHIELD WASHER, 594-701
14	1	291631	LENS, HAZARD 595-417
15	2	291632	LENS, DIRECTION INDICATOR
16	1	658174	RUBBER BUMPER, 1.0000D .500GD
17	8	293246	END BEZEL, 594-802
18	4	293247	CENTER BEZEL, 594-801
19	2	298004	20 AMP FUSE SFE 20
20	6	298011	FUSE HOLDER
21	6	903708	1/4UNC X1/2 PHIL PNHD MACHSCR
22	1	321021	IGN SWITCH, NON-SEALED
23	1	342657	CONSOLE COVER PNL, 284 CUMM 99
24	1	470223	SNAP BUSHING, BLK NYL, .50DIA
25	3	291776	BLANK COVER, 596-273
26	1	390318	INDICATOR LIGHT, RED

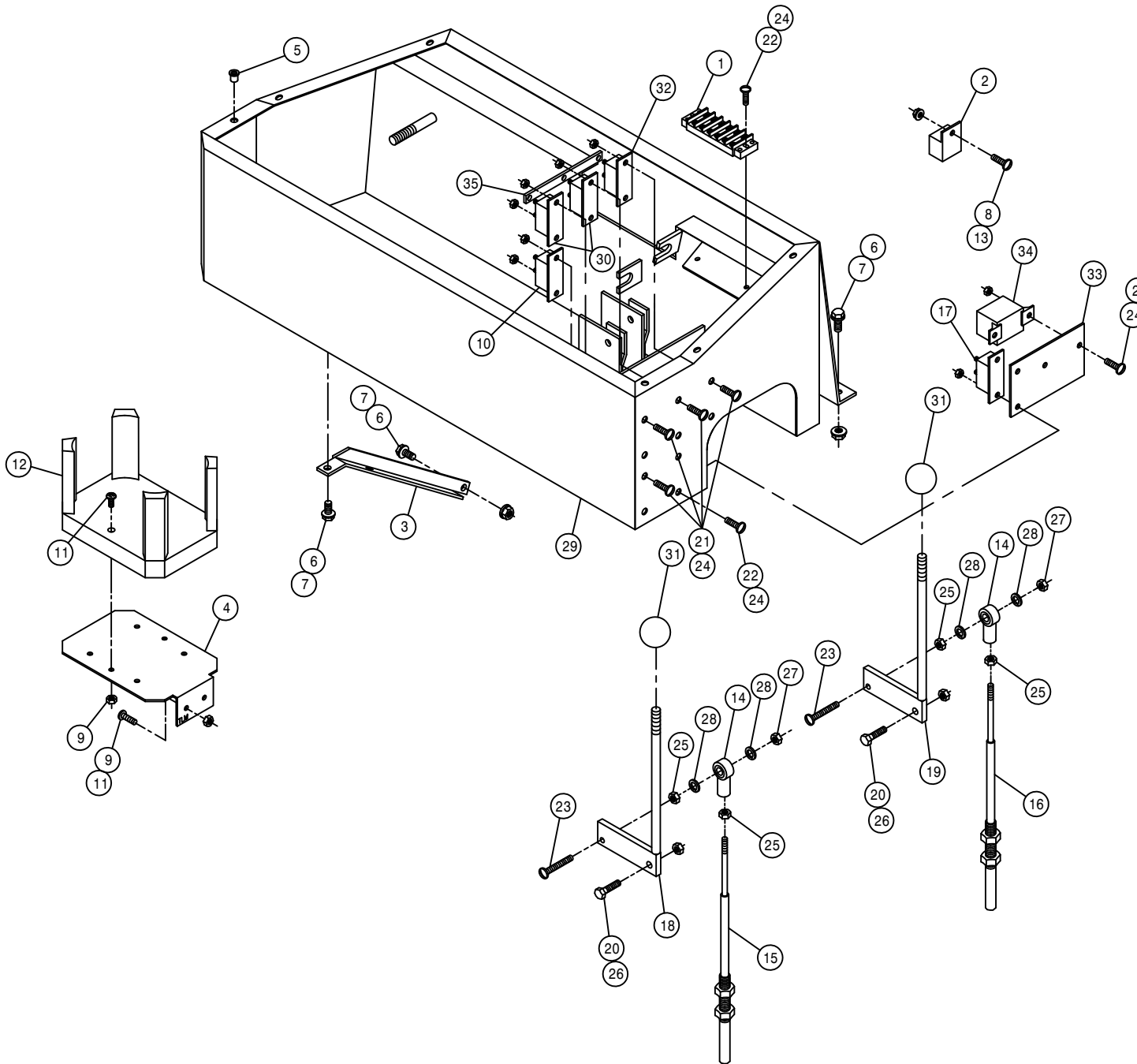

CONSOLE ASSEMBLY

DET.	QTY	PART NO.	DESCRIPTION
1	1	293093	TERMINAL BLOCK 6 POS - 2 ROW
2	1	291640	RELAY, 12V 20/30AMP BOSCH
3	1	342282	CONSOLE BRACE 254/284 95
4	1	342216	DRINK HOLDER MT BRKT 94
5	6	470380	1/4-20 NUTSERT .027-.165 STL
6	5	470118	1/4UNC X 3/4 FLANGE HEX BOLT
7	5	470121	1/4UNC HEX FLANGE LOCK NUT
8	1	903844	8-32 X 1/2 SLT RD HD MACH SCR
9	4	470175	10-32 HEX FLANGE LOCK NUT
10	1	291551	CIRCUIT BREAKER,15AMP,INLINEMT
11	4	903710	10-32X5/8 PHIL PANHD MACH SCR
12	1	470214	SPILLMASTER DRINK HOLDER
13	1	910024	8-32 HEX NUT
14	2	473921	BALL JOINT NO 10-32 THD
15	1	785063	CTRL CABLE 10-32 2IN X 42 LG
16	1	785064	CTRL CABLE 10-32 2IN X 53 LG
17	1	291552	CIRCUIT BREAKER,20AMP,INLINEMT
18	1	785070	SOLU PRESS CTRL LEVER WLD 94
19	1	785073	AGIT CTRL LEVER WLD 94
20	2	900003	1/4UNC X 1" HEX BOLT
21	8	903812	6-32 X 1/2 SLT RD HD MACH SCR
22	6	903814	6-32 X 3/4 SLT RD HD MACH SCR
23	2	903893	10-32 X 1" SLT RD HD MACH SCR
24	14	910022	6-32 HEX NUT
25	4	910027	10-32 HEX NUT
26	2	914000	1/4UNC HEX STOVER NUT
27	2	914027	10-32 HEX STOVER NUT
28	4	920510	#10 LOCK WASHER
29	1	342191	CONSOLE WLD, 284 CAB 94
30	2	291197	CIRCUIT BREAKER,30AMP,INLINEMT
31	2	659291	KNOB,1" RND,BLK, 3/8-16
32	1	291024	CIRCUIT BREAKER,40AMP,INLINEMT
33	1	343327	RELAY MT, CONSOLE DTS 8/8T 05
34	1	657371	RELAY, 12 VOLT 75 AMP
35	1	291351	BUSS BAR,3 GANG CIRCUIT BREAKR

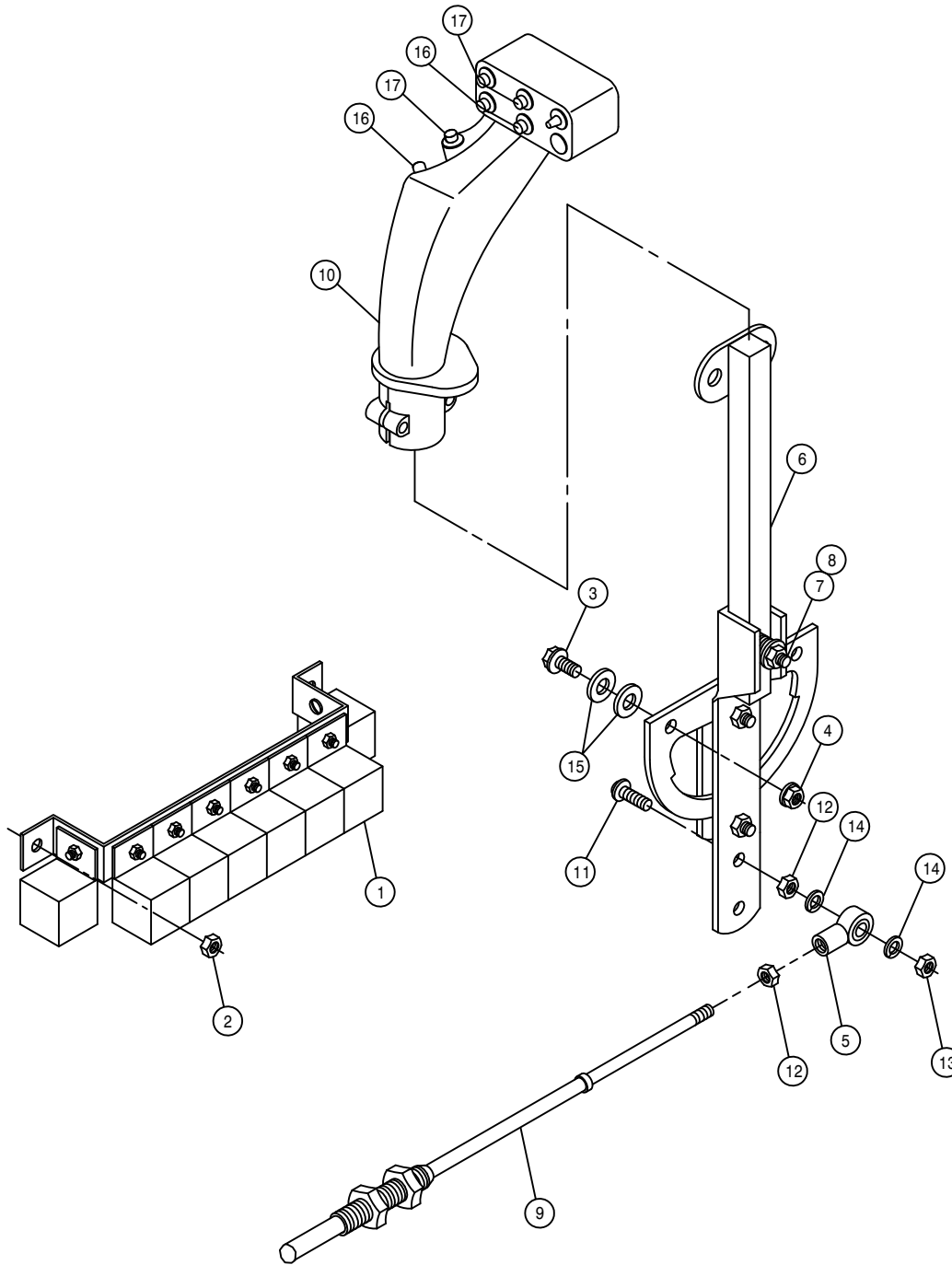

HYDROSTATIC LEVER ASSEMBLY

DET. QTY PART NO. DESCRIPTION

1	8	291640	RELAY, 12V 20/30AMP BOSCH
2	2	470175	10-32 HEX FLANGE LOCK NUT
3	2	470118	1/4UNC X 3/4 FLANGE HEX BOLT
4	2	470121	1/4UNC HEX FLANGE LOCK NUT
5	1	473921	BALL JOINT NO 10-32 THD
6	1	606907	HYDST CTRL LEVER ASSY 204-284
7	1	900005	1/4UNC X 1 1/2 HEX BOLT
8	1	914000	1/4UNC HEX STOVER NUT
9	1	785003	CTRL CABLE 10-32 4IN X 112 LG
10	1	785083	FASSE EZ-3 CTRL HANDLE,284 04
11	1	903893	10-32 X 1" SLT RD HD MACH SCR
12	2	910027	10-32 HEX NUT
13	1	914027	10-32 HEX STOVER NUT
14	2	920510	#10 LOCK WASHER
15	4	920000	1/4 SAE FLAT WASHER
16	3	291884	SWITCH,PB 3TRM MOM 0, GRAY
17	3	291883	SWITCH,PB 3TRM MOM 0, RED

THROTTLE LEVER ASSEMBLY

DET. QTY PART NO. DESCRIPTION

1	1	499001	SPRING HYDRO CONTROL
2	1	785007	KNOB, 1 3/16" BALL, RED, 3/8-16
3	1	785046	FRICTION DISC 3-333 X .38
4	1	785066	CTRL CABLE 10-32 4IN X 129 IN
5	1	785067	THROT LEVER WLD, GAS/DIESEL 94
6	1	903893	10-32 X 1" SLT RD HD MACH SCR
7	2	910027	10-32 HEX NUT
8	1	914004	3/8UNC HEX STOVER NUT
9	1	914027	10-32 HEX STOVER NUT
10	1	920002	3/8 SAE FLAT WASHER
11	2	920510	#10 LOCK WASHER
12	1	473921	BALL JOINT NO 10-32 THD

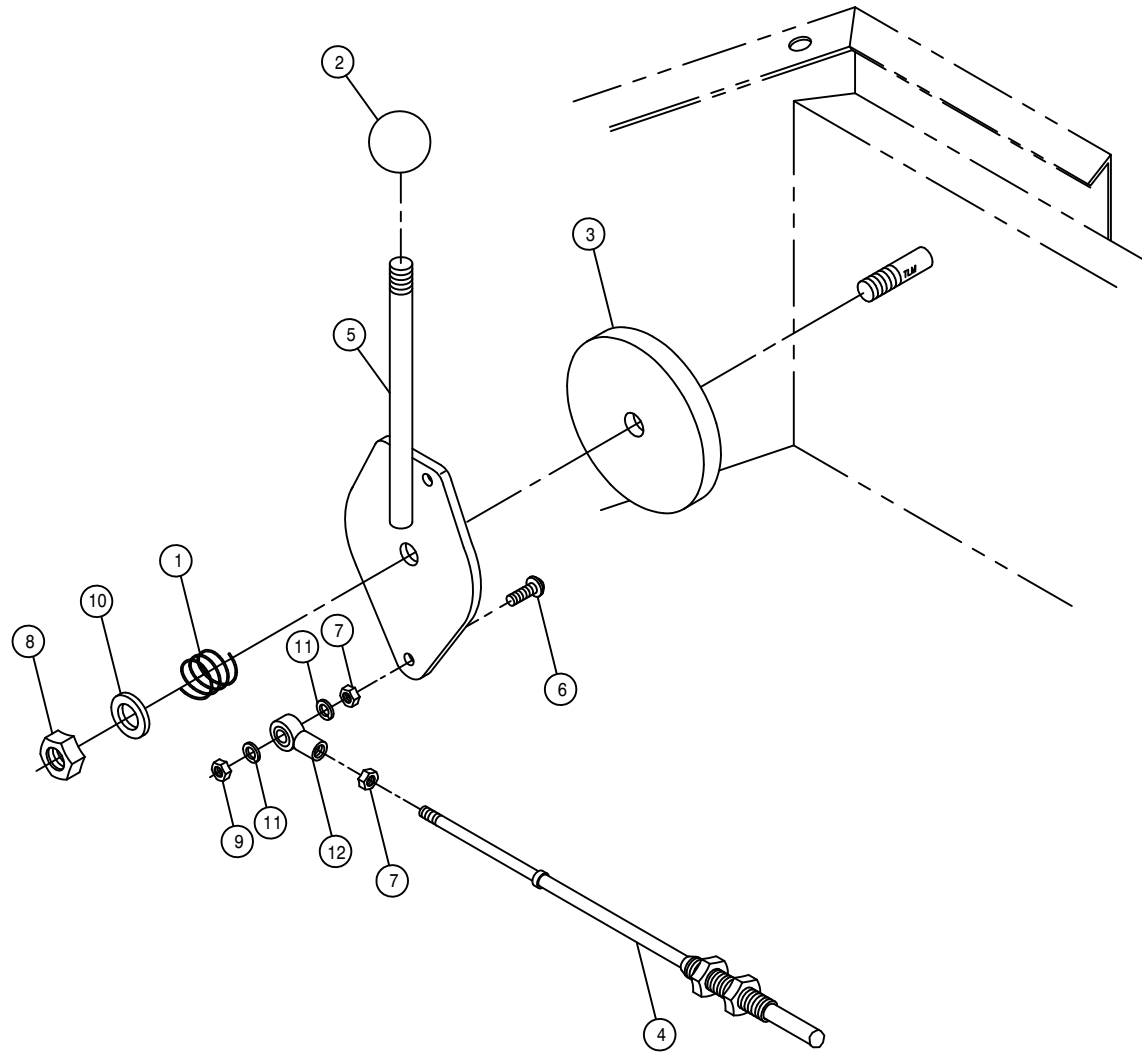

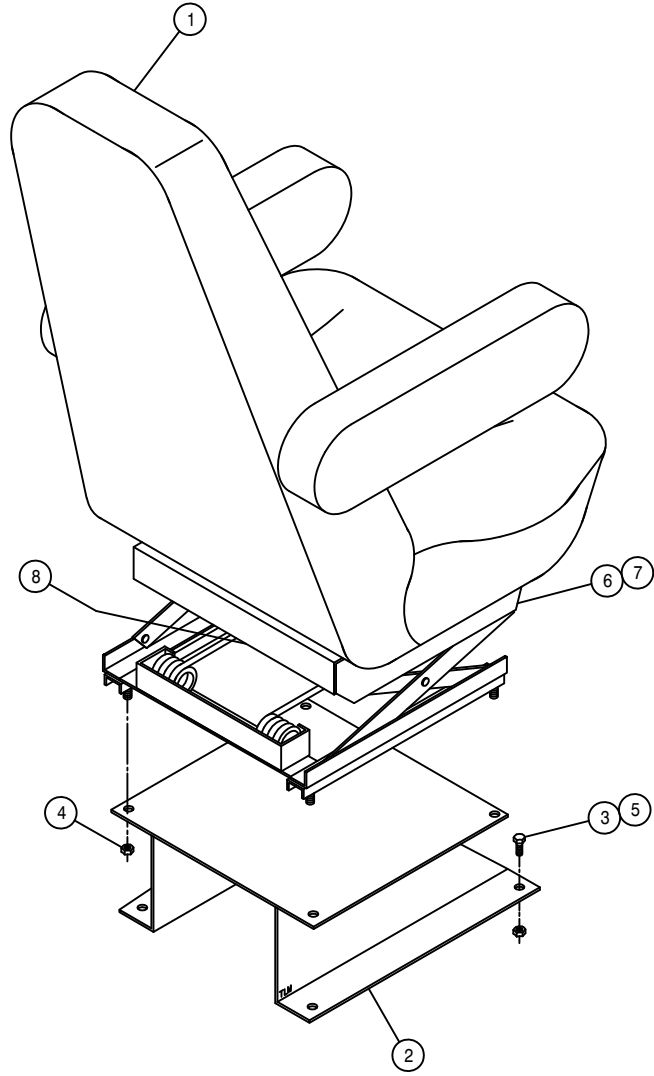

SEAT ASSEMBLY

DET. QTY PART NO. DESCRIPTION

1	1	330022	SEAT, MAGNUM-100 AIR SUSPEND95
2	1	342090	SEAT MT WELD, 254/284 95
3	4	900129	3/8UNC X 1" HEX BOLT
4	4	914002	5/16UNC HEX STOVER NUT
5	4	914004	3/8UNC HEX STOVER NUT
6	1	330024	HEIGHT ADJ LATCH, SEAT 330022
7	1	330025	ADJ LATCH SPRING, SEAT 330022
8	1	330023	AIR BAG PKG, SEAT 330022

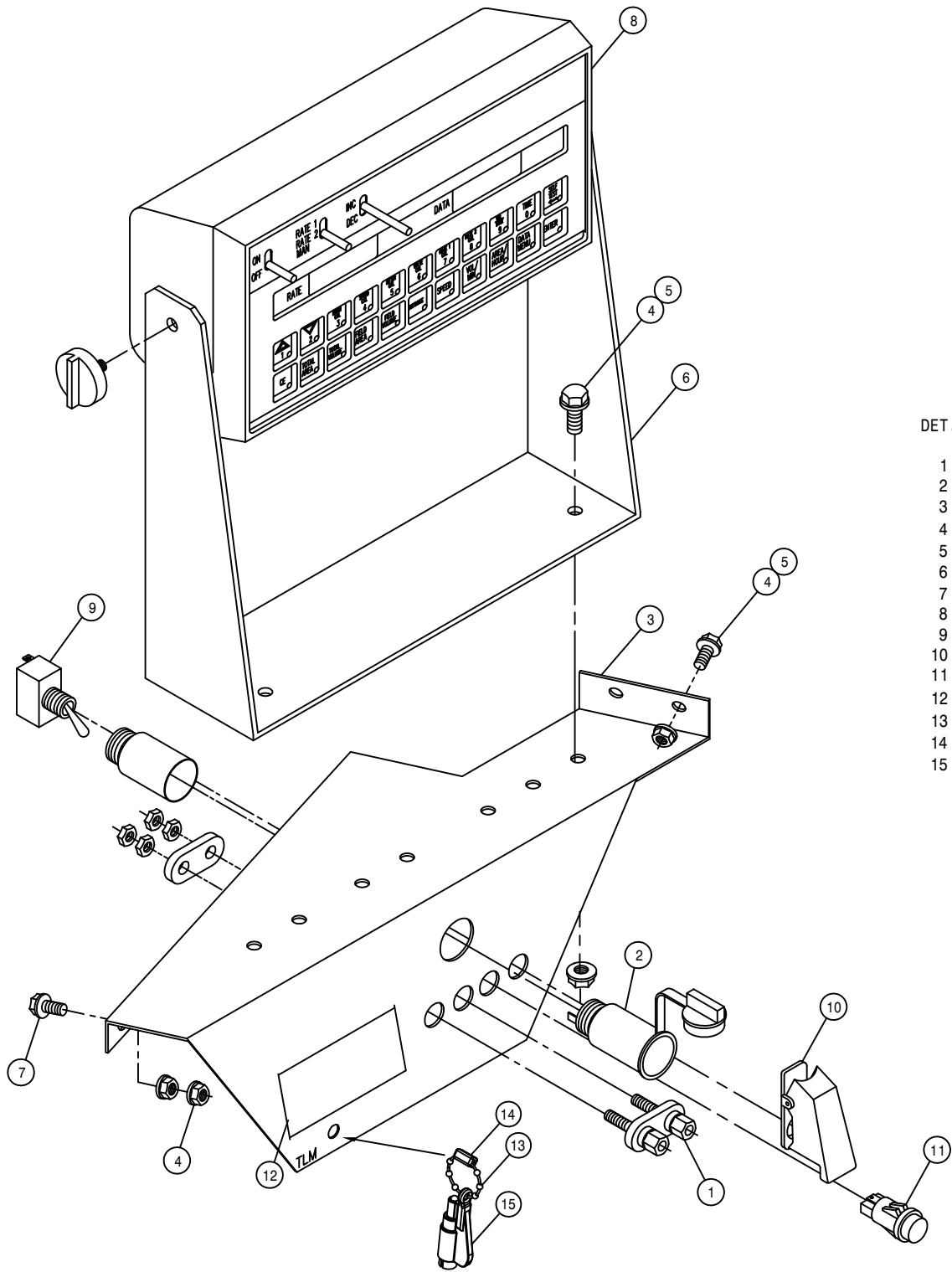

MONITOR MOUNTING BRACKET ASSEMBLY

DET. QTY PART NO. DESCRIPTION

1	1	291647	DUAL BINDING POSTS
2	1	291648	POWER POINT RECEPTACLE
3	1	343201	MONITOR MT, 284XP CAB 2001
4	7	470121	1/4UNC HEX FLANGE LOCK NUT
5	5	470122	1/4UNC X 1/2 FLANGE HEX BOLT
6	1	690498	CONSOLE MT, RAVEN 460 95
7	1	470118	1/4UNC X 3/4 FLANGE HEX BOLT
8	1	690890	CONSOLE, RAVEN 460, SPANISH
9	1	298012	TOGGLE SWITCH, ON-OFF, SPST, 15A
10	1	291655	AIRCRAFT TOGGLE SWITCH GUARD
11	1	390318	INDICATOR LIGHT, RED
12	1	650175	DECAL, NOTICE EMERGENCY EXIT
13	1	470398	BEAD CHAIN, #10 X 4" LONG
14	1	470400	BEAD CHAIN CONNECTOR #10 WHITE
15	1	470397	RES-Q-ME TOOL

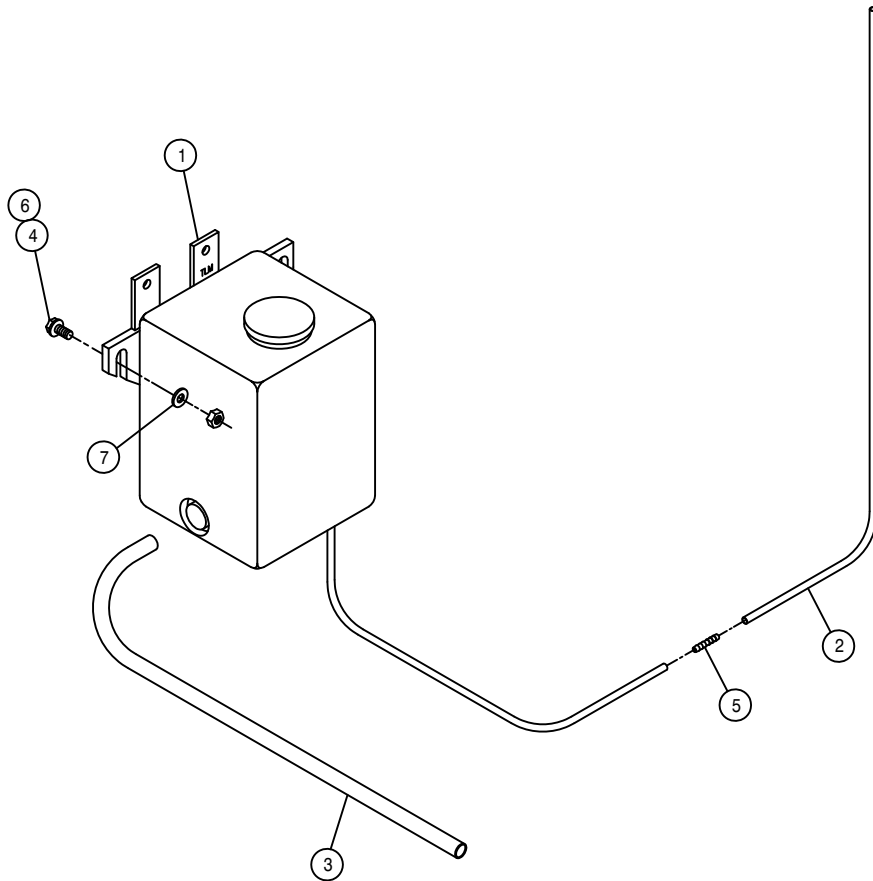

WINDSHIELD WASHER ASSEMBLY

DET. QTY PART NO. DESCRIPTION

1	1	290002	WINDSHIELD WASHER KIT
2	14	195913	7/64" WINDSHIELD WASHER HOSE
3	13	299110	.35 ID WIRE FLEX GUARD
4	3	470231	1/4UNC X 1" FLANGE HEX BOLT
5	1	711033	3/16-1/8 HOSE BARB REDU UNION
6	3	914000	1/4UNC HEX STOVER NUT
7	3	920000	1/4 SAE FLAT WASHER



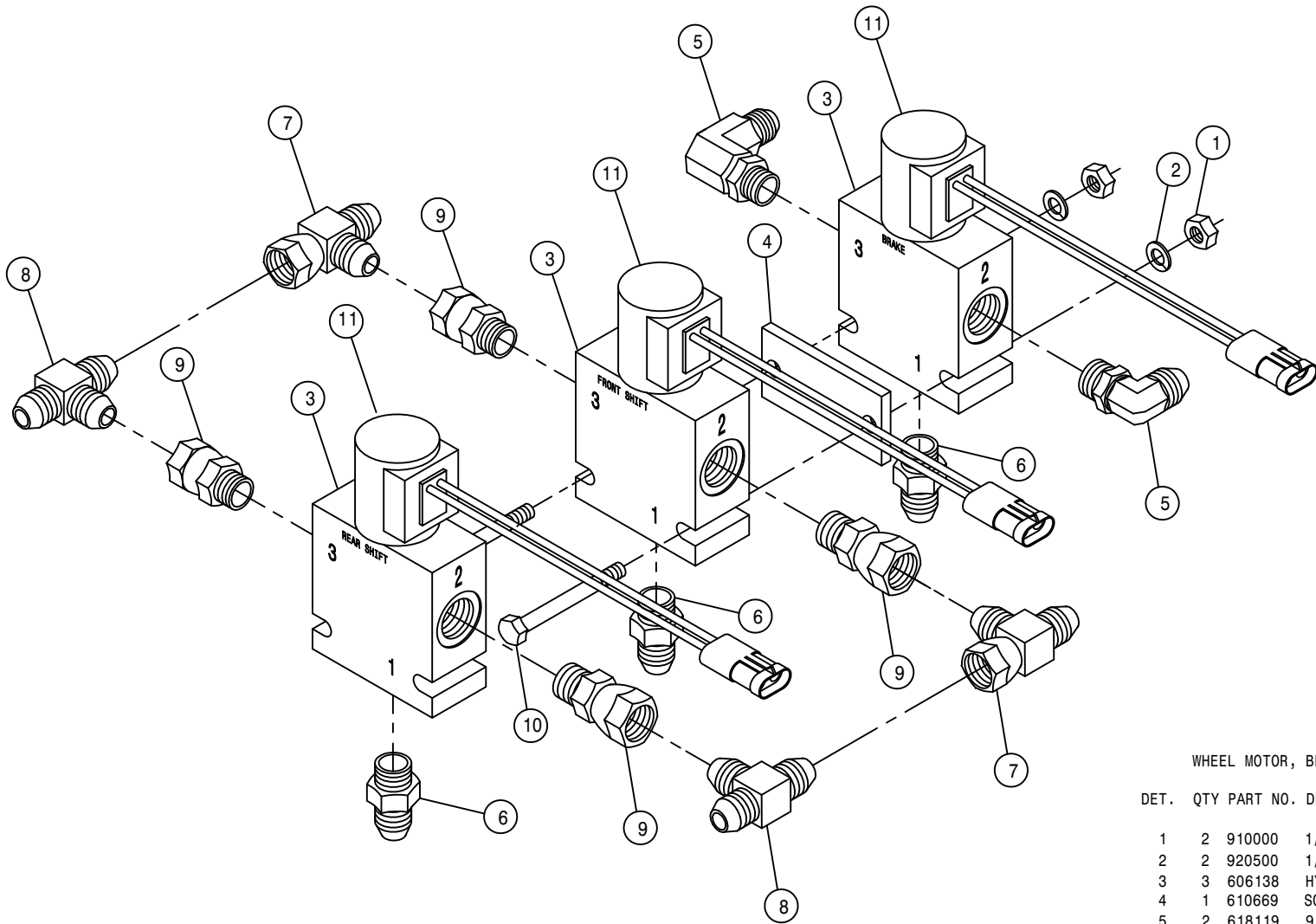

WHEEL MOTOR, BRAKE VALVE ASSEMBLY

DET. QTY PART NO. DESCRIPTION

1	2	910000	1/4UNC HEX NUT
2	2	920500	1/4 LOCK WASHER
3	3	606138	HYD SOLE VLV,2P-3W,9/16FOR, WP
4	1	610669	SOLE VLV SPACER
5	2	618119	9/16MJIC-90-9/16MOR LBO
6	3	618126	9/16MJIC-9/16MOR ADPTR
7	2	618486	9/16FJIC SW RUN TEE-9/16MJIC
8	2	618019	9/16MJIC UNION TEE
9	4	618668	9/16FJIC SWIV-9/16MOR ADPTR
10	2	900010	1/4UNC X 3" HEX BOLT
11	3	610016	COIL FOR HYD VLV 610318

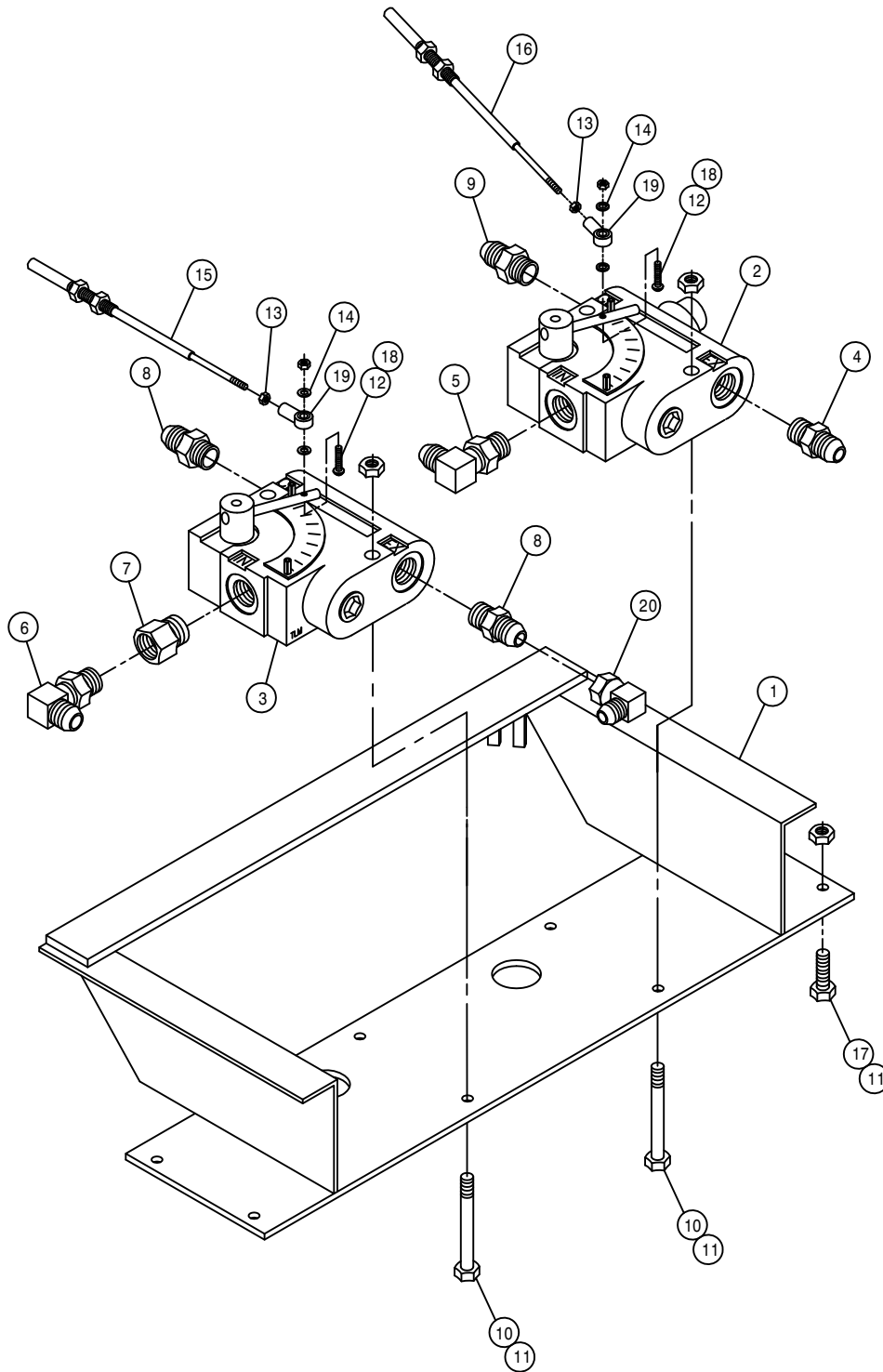

VARIABLE FLOW CONTROL ASSEMBLY

DET.	QTY	PART NO.	DESCRIPTION	
	1	342209	SOLU VFC MT WLD	94
	2	606818	FLO CONT FCR51 0-16GPM 7/8FOR	
	3	606827	FLO CONT FC51 0-3 VARI 7/8FOR	
	4	611126	7/8MJIC-7/8MOR ADPTR	
	5	611128	7/8MJIC-90-7/8MOR LBO	
	6	618119	9/16MJIC-90-9/16MOR LBO	
	7	618172	7/8MOR-9/16FOR ADPTR	
	8	618310	9/16MJIC-7/8MOR ADPTR	
	9	618327	3/4MJIC-7/8MOR ADPTR	
	10	900008	1/4UNC X 2 1/2 HEX BOLT	
	11	914000	1/4UNC HEX STOVER NUT	
	12	903893	10-32 X 1" SLT RD HD MACH SCR	
	13	910027	10-32 HEX NUT	
	14	920510	#10 LOCK WASHER	
	15	785064	CTRL CABLE 10-32 2IN X 53 LG	
	16	785063	CTRL CABLE 10-32 2IN X 42 LG	
	17	470118	1/4UNC X 3/4 FLANGE HEX BOLT	
	18	914027	10-32 HEX STOVER NUT	
	19	473921	BALL JOINT NO 10-32 THD	
	20	618618	9/16MJIC-90-9/16FJIC SWIV LBO	

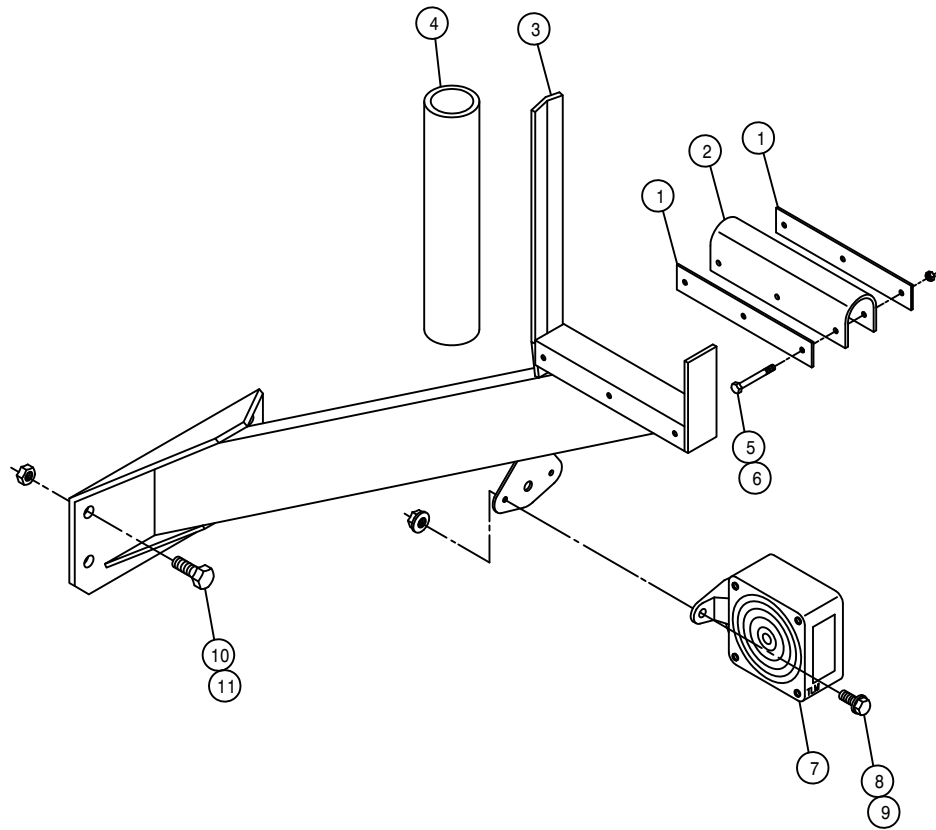

BOOM CRADLE ASSEMBLY

DET.	QTY	PART NO.	DESCRIPTION	
1	4	164254	CRADLE CUSHION KEEPER	96
2	2	164256	BOOM CRADLE CUSHION	96
3	2	164746	BOOM CRADLE WLD, 284TXP	03
4	2	601184	HOSE, 1 1/2 X 14 2BR BLK EPDM	
5	6	900010	1/4UNC X 3" HEX BOLT	
6	6	914000	1/4UNC HEX STOVER NUT	
7	2	291604	TURN SIGNAL LIGHT,PED MT, YEL	
8	4	470118	1/4UNC X 3/4 FLANGE HEX BOLT	
9	4	470121	1/4UNC HEX FLANGE LOCK NUT	
10	8	900334	5/8UNC X 1 3/4 HEX BOLT	
11	8	914010	5/8UNC HEX STOVER NUT	

NOTE: QUANTITY LISTED IS FOR ONE MACHINE.

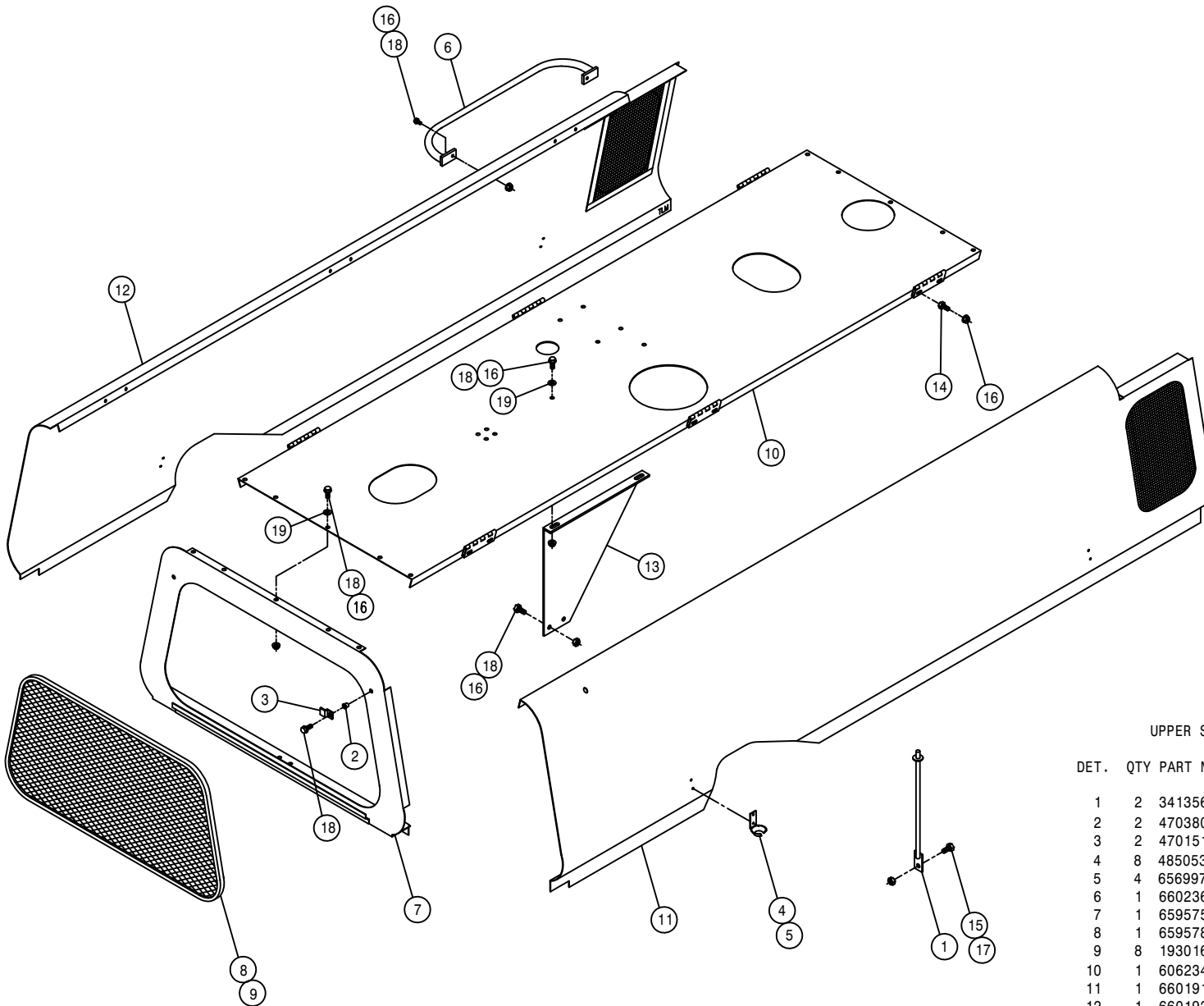

UPPER SHEET METAL ASSEMBLY

DET. QTY PART NO. DESCRIPTION

1	2	341356	ENGINE HOOD PROP WLD 8240 82
2	2	470380	1/4-20 NUTSERT .027-.165 STL
3	2	470151	UPPER REAR PANEL SCREEN CLIP
4	8	485053	POP RIVET 3/16 X 3/8
5	4	656997	RUBBER HOOK BRKT
6	1	660236	ENG HOOD HANDRAIL WLD, 284 04
7	1	659575	UPPER REAR PANEL WLD 8240 82
8	1	659578	UPPER REAR PANEL SCREEN 8240
9	8	193016	QUICKEDGE TRIM .060 TO .170
10	1	606234	SUND 75CC PUMP, C/B MT (.022)
11	1	660191	RH ENG HOOD WLD 284XP 2001
12	1	660192	LH ENG HOOD WLD 284XP 2001
13	1	659930	MULLION SUPPORT BRKT, 284 97
14	12	900000	1/4UNC X 1/2 HEX BOLT
15	2	900128	3/8UNC X 3/4 HEX BOLT
16	28	470121	1/4UNC HEX FLANGE LOCK NUT
17	2	914004	3/8UNC HEX STOVER NUT
18	18	470118	1/4UNC X 3/4 FLANGE HEX BOLT
19	12	470212	1/4 BONDED SEALING WASH, SS

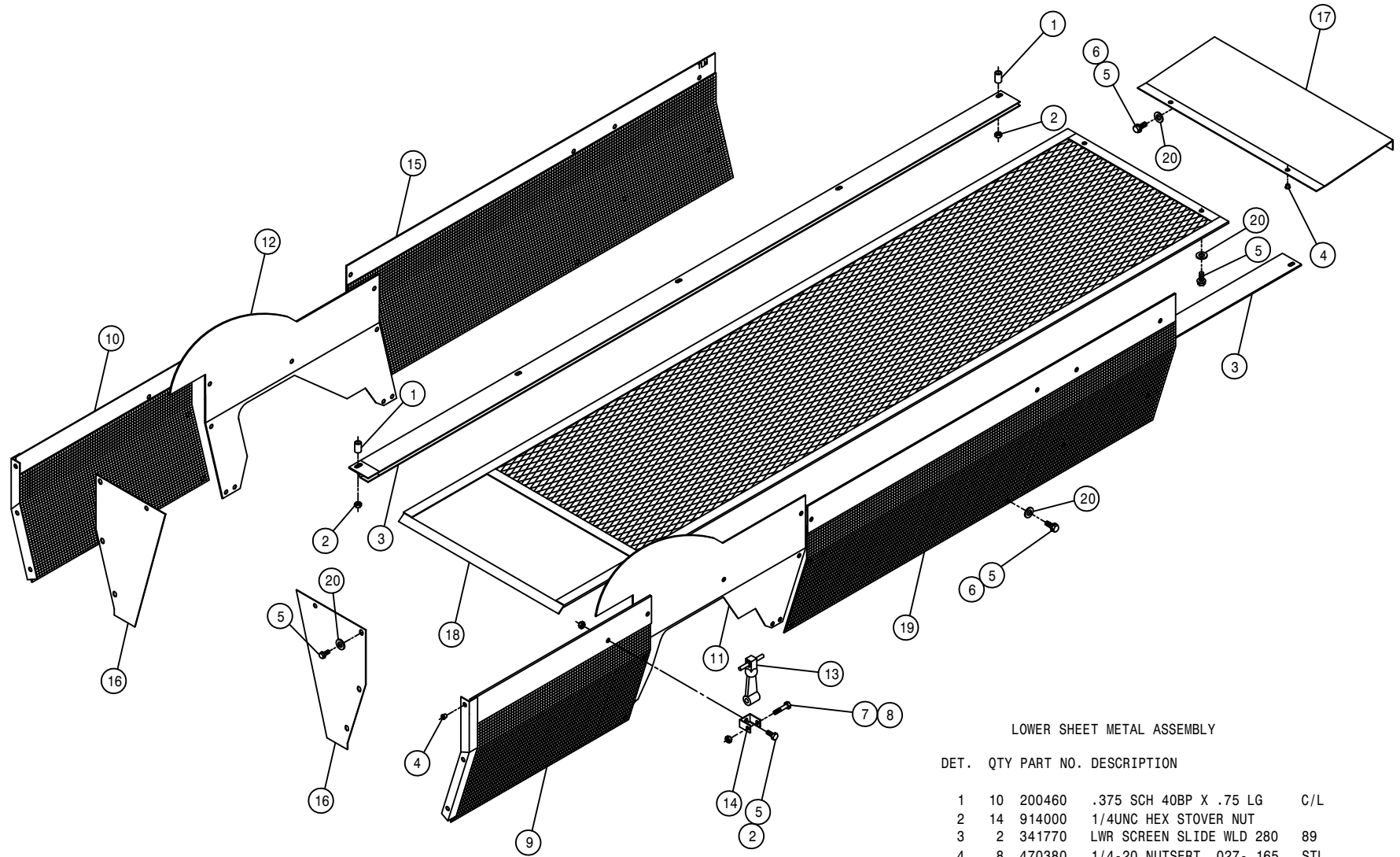

LOWER SHEET METAL ASSEMBLY

DET. QTY PART NO. DESCRIPTION

DET.	QTY	PART NO.	DESCRIPTION	
1	10	200460	.375 SCH 40BP X .75 LG	C/L
2	14	914000	1/4UNC HEX STOVER NUT	
3	2	341770	LWR SCREEN SLIDE WLD 280	89
4	8	470380	1/4-20 NUTSERT .027-.165	STL
5	27	470118	1/4UNC X 3/4 FLANGE HEX BOLT	
6	17	470121	1/4UNC HEX FLANGE LOCK NUT	
7	4	900006	1/4UNC X 1 3/4 HEX BOLT	
8	4	470089	1/4UNC HEX NYLOC NUT, 316 SS	
9	1	659889	RH REAR SIDE SCR N WLD 2XX	92
10	1	659890	LH REAR SIDE SCR N WLD 2XX	92
11	1	660195	RH LWR SIDE SHIELD, 284XP 2001	
12	1	660196	LH LWR SIDE SHIELD, 284XP 2001	
13	4	656998	RUBBER HOOK	
14	4	656999	RUBBER HOOK ANCHOR BRKT	
15	1	659907	LH FRT SIDE SCR N WLD, 284	94
16	2	660209	LWR REAR PANEL 284TXP	2003
17	1	659803	LWR FRT SHIELD 280	89
18	1	659804	LWR SCREEN WLD 280	89
19	1	659906	RH FRT SIDE SCR N WLD, 284	94
20	29	470212	1/4 BONDED SEALING WASH, SS	

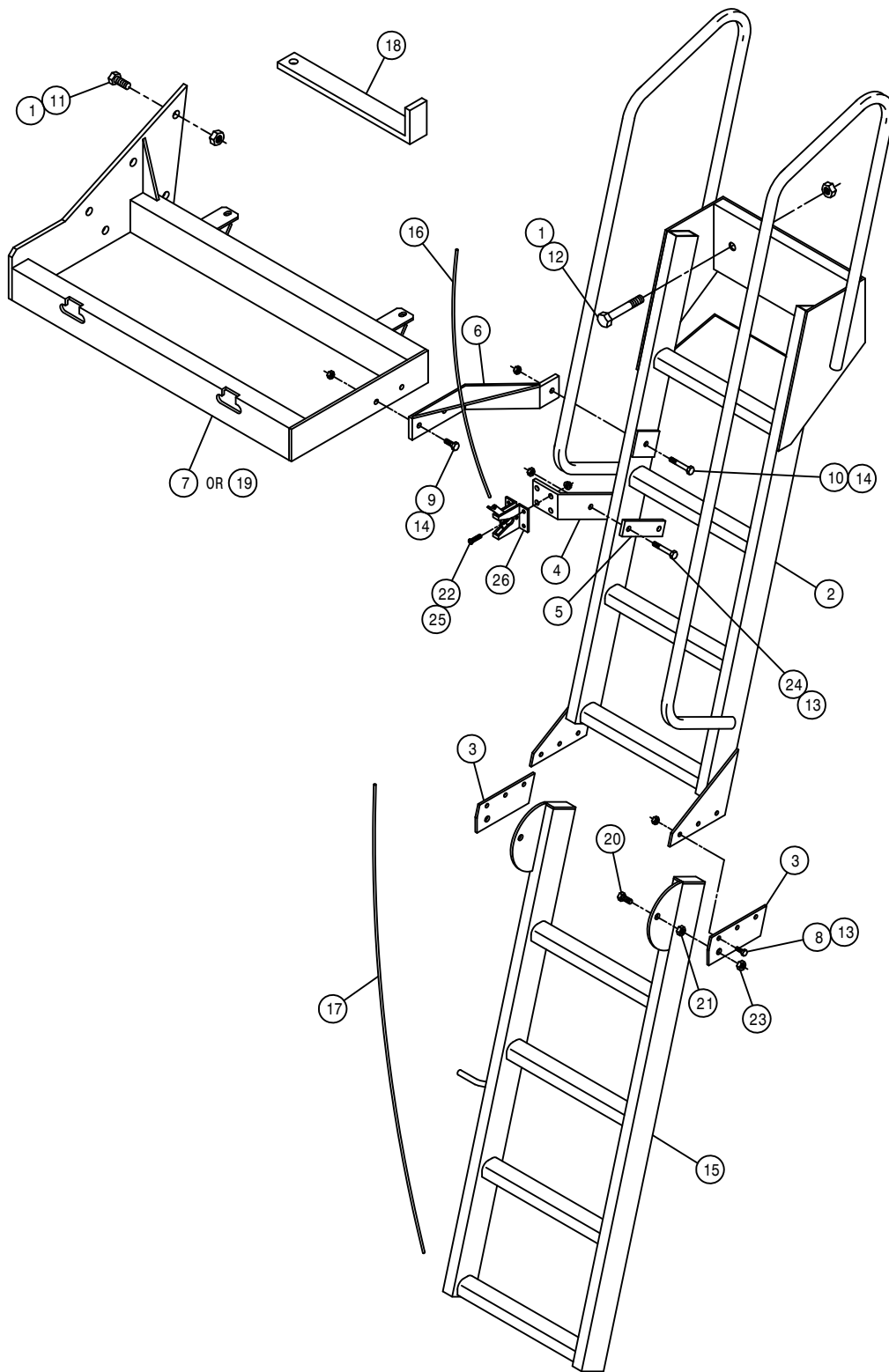

LADDER ASSEMBLY

DET. QTY PART NO. DESCRIPTION

1	14	914010	5/8UNC HEX STOVER NUT	
2	1	342605	LH LADDER WLD, 2100	98
3	2	343279	LADDER EXTEN MT PLT, 284TXP	03
4	1	343280	LADDER LATCH MT, 284TXP	03
5	1	343281	LADDER LATCH MT KEEPER, 284TXP	
6	1	343260	LH LADDER BRACE WLD, 284TXP	03
7	1	760216	LH FUEL TANK MT WLD, 2100	98
8	6	900065	5/16UNC X 1" HEX BOLT	
9	2	900130	3/8UNC X 1 1/4 HEX BOLT	
10	1	900133	3/8UNC X 2" HEX BOLT	
11	12	900334	5/8UNC X 1 3/4 HEX BOLT	
12	2	900829	5/8UNC X 4" HEX BOLT GR8	
13	8	914002	5/16UNC HEX STOVER NUT	
14	3	914004	3/8UNC HEX STOVER NUT	
15	1	343282	LADDER EXTENSION WLD, 284TXP	03
16	1	343288	1/8 X 64" NYLON ROPE	
17	1	343289	3/8 X 136" NYLON ROPE	
18	2	343262	REAR HOSE SUPPORT, 284TXP	03
19	1	760286	RH FUEL TANK MT WLD, 284TXP	03
20	2	900266	1/2UNC X 1 3/4 HEX BOLT	
21	2	910008	1/2UNC HEX NUT	
22	4	472235	10-32 X 3/4 PHIL HD MACH SCR	
23	2	914008	1/2UNC HEX STOVER NUT	
24	2	900069	5/16UNC X 2" HEX BOLT	
25	4	470175	10-32 HEX FLANGE LOCK NUT	
26	1	470357	GRAVITY DOOR LATCH, FLUSH MT	

FUEL TANK ASSEMBLY

DET. QTY PART NO. DESCRIPTION

1	2	291428	FUEL SENDER 19 IN.	
2	10	473902	NO 8 X 1/2 PAN HD MET SC	
3	2	501102	1/4 PIPE PLUG	
4	8	501451	BLK PIPE EL 90DEG .25NPT	
5	4	501602	BLK PIPE NIPPLE .25NPT-1.50	
6	2	760179	FUEL TANK WLD, 2100	98
7	2	761200	GAS CAP	
8	2	783303	1/4 NPT X 5/16 HOSE BARB, BRS	
9	2	783304	1/4 NPT X 3/8 HOSE BARB, BRS	
10	4	760184	FUEL TANK BAND WLD, 2100	98
11	4	914004	3/8UNC HEX STOVER NUT	
12	14	520120	HOSE CLAMP NO 4 STAINLESS	
13	1	601421	HOSE, 5/16 X 50 FUEL LINE	
14	2	601324	HOSE, 3/8 X 90 FUEL LINE	
15	2	601545	HOSE, 5/16 X 108 FUEL LINE	
16	2	316281	FUEL STRAINER, IN-LINE, DIESEL	
17	2	601528	HOSE, 3/8 X 9 FUEL LINE	
18	1	601322	HOSE, 3/8 X 26 FUEL LINE	
19	1	610529	FUEL SELECTOR VALVE W/RETURN	
20	2	291464	GSKT FUEL SENDER, FOR291428	
21	2	900064	5/16UNC X 3/4 HEX BOLT	
22	4	470121	1/4UNC HEX FLANGE LOCK NUT	

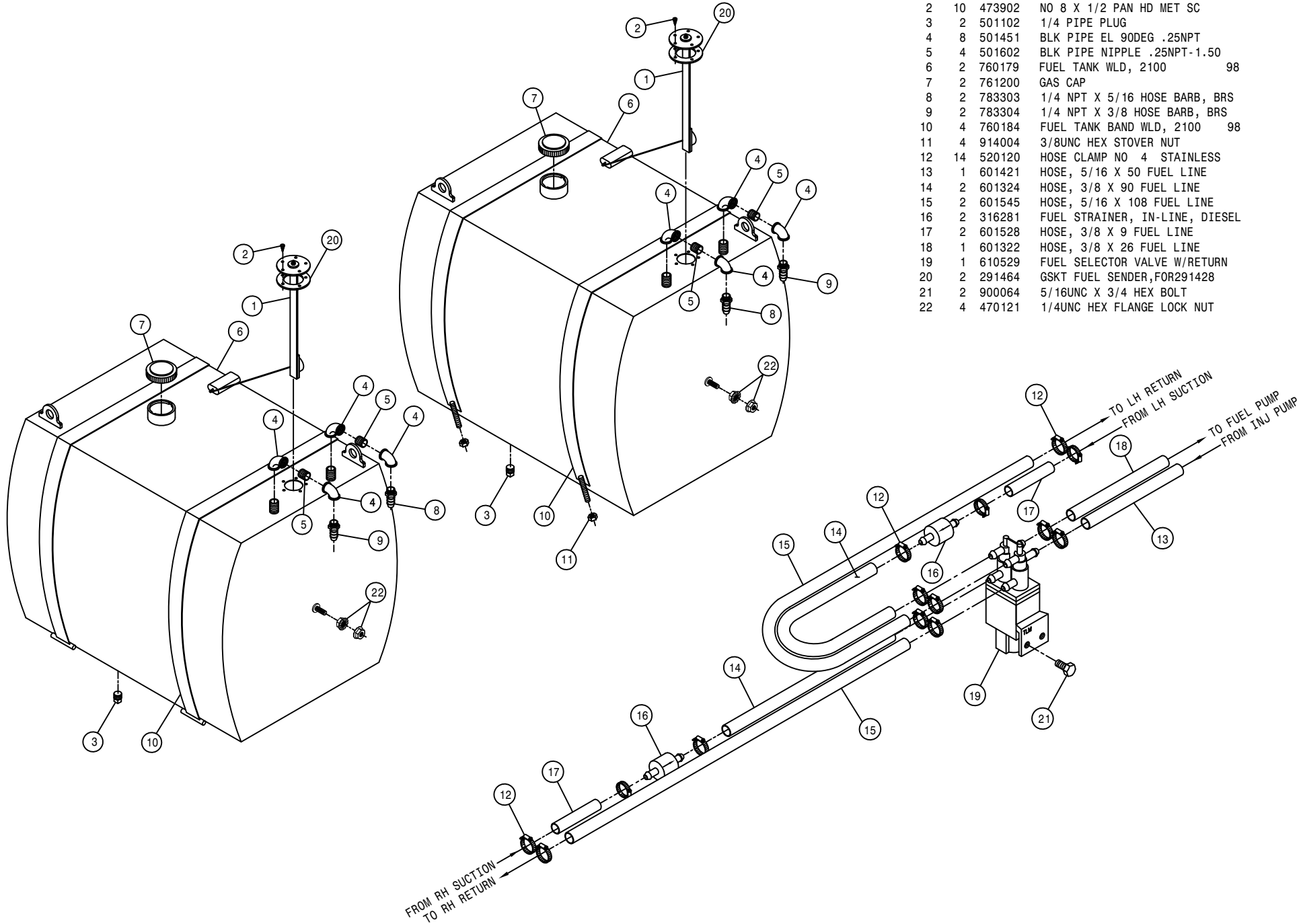

SERVICE PLATFORM ASSEMBLY

DET. QTY PART NO. DESCRIPTION

1	2	291694	RED LAMP, 6 1/2" OVAL 12.8V
2	2	291697	RUBBER MT FOR 6 1/2" OVAL LAMP
3	2	293515	3-WIRE PIGTAIL ASSY
4	1	343265	REAR PLATFORM WLD, 284TXP 03
5	1	342872	RH SERV PLATFORM WLD,284XP 01
6	1	342873	LH SERV PLATFORM WLD,284XP 01
7	1	342875	RH FRT SERV PLTFRM MT WLD XP
8	1	342876	LH FRT SERV PLTFRM MT WLD XP
9	1	342879	RH REAR SERV PLTFRM WLD XP 01
10	1	342880	LH REAR SERV PLTFRM WLD XP 01
11	1	343274	REAR HANDRAIL WLD, 284TXP 03
12	1	342896	LH FRT PLTFRM HANDRAIL WLD XP
13	1	342900	LH REAR PLTFRM HANDRAIL WLD XP
14	1	472251	MTG SOCKET
15	1	472249	SLOW MOVING VEHICLE SIGN
16	1	472250	SPADE MTG BRKT
17	2	470118	1/4UNC X 3/4 FLANGE HEX BOLT
18	2	470121	1/4UNC HEX FLANGE LOCK NUT
19	12	900065	5/16UNC X 1" HEX BOLT
20	4	900071	5/16UNC X 2 3/4 HEX BOLT
21	4	900129	3/8UNC X 1" HEX BOLT
22	6	900334	5/8UNC X 1 3/4 HEX BOLT
23	4	900340	5/8UNC X 3 1/2 HEX BOLT
24	16	914002	5/16UNC HEX STOVER NUT
25	4	914004	3/8UNC HEX STOVER NUT
26	10	914010	5/8UNC HEX STOVER NUT
27	2	920006	3/4 SAE FLAT WASHER
28	2	470162	COTTER PIN 3/16 X 1 1/2 SQCUT

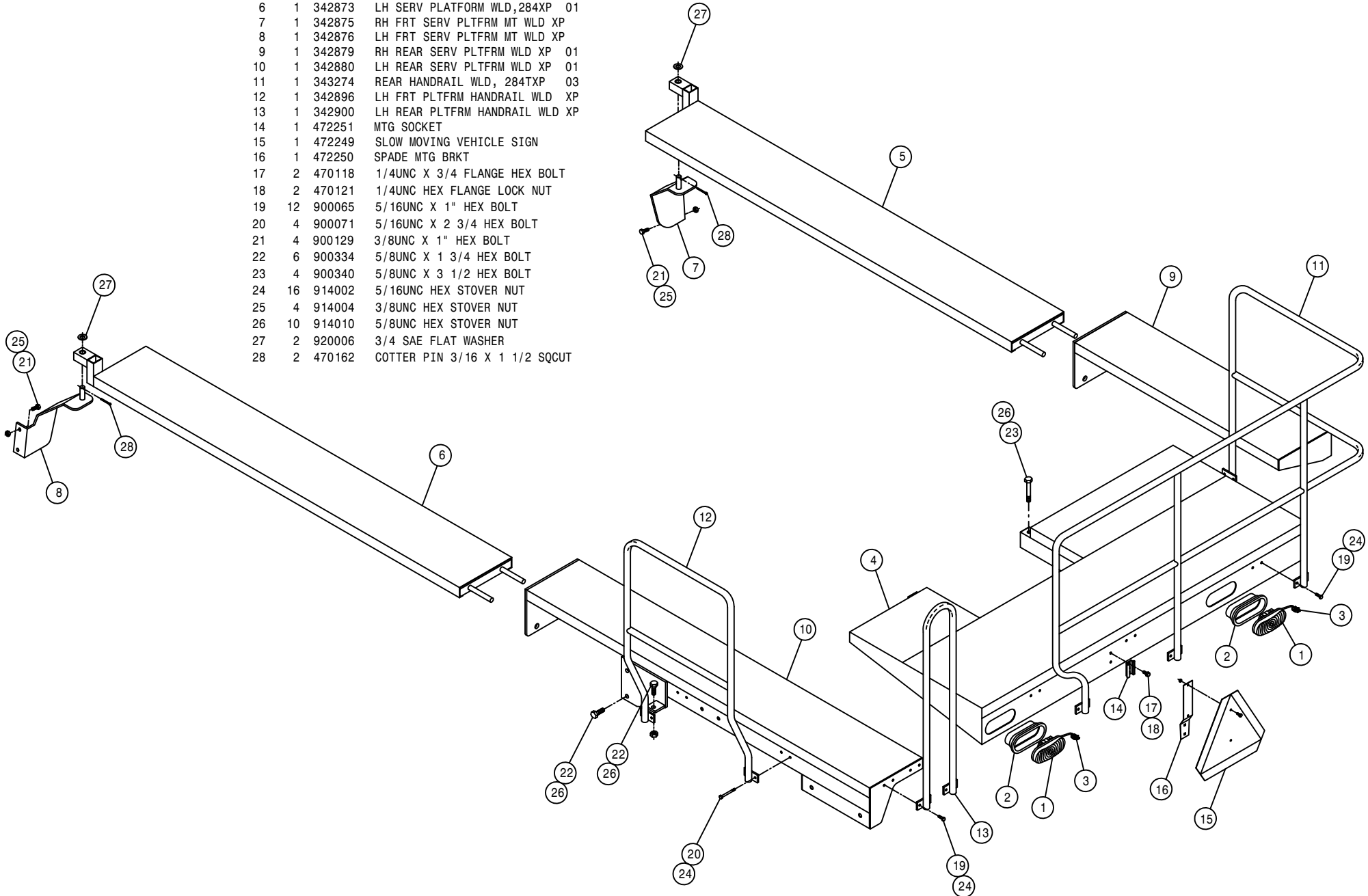



SOLUTION TANK MOUNTS AND SHIELDS

DET. QTY PART NO. DESCRIPTION

DET.	QTY	PART NO.	DESCRIPTION
1	4	160621	SPRING TIGHTENER HOOK BUSH
2	12	470118	1/4UNC X 3/4 FLANGE HEX BOLT
3	16	470121	1/4UNC HEX FLANGE LOCK NUT
4	2	358961	LEG BRACE CLEVIS WLD, 2100 99
5	2	359140	LEG BRACE WLD 284XP 2001
6	4	763490	SOLU TANK MT SUPP, 2100 98
7	1	659831	LWR FRONT SHIELD 280 89
8	1	660200	RH FRT POLY TANK SHLD WLD280XP
9	1	660201	LH FRT POLY TANK SHLD WLD280XP
10	1	763580	RH FRT SOLU TANK MT WLD 284XP
11	1	763581	LH FRT SOLU TANK MT WLD 284XP
12	1	763582	RH REAR SOLU TANK MT WLD 284XP
13	1	763583	LH REAR SOLU TANK MT WLD 284XP
14	4	900006	1/4UNC X 1 3/4 HEX BOLT
15	8	920000	1/4 SAE FLAT WASHER
16	4	900410	3/4UNC X 4" HEX BOLT
17	2	900814	1" UNC X 4" HEX BOLT GR8
18	8	900334	5/8UNC X 1 3/4 HEX BOLT
19	8	900412	3/4UNC X 5" HEX BOLT
20	4	910017	1" UNC HEX NUT
21	12	914010	5/8UNC HEX STOVER NUT
22	12	914012	3/4UNC HEX STOVER NUT
23	8	920008	1" SAE FLAT WASHER
24	4	920508	1" LOCK WASHER
25	2	659919	FRT SHIELD EXT, D230 PUMP
26	4	900335	5/8UNC X 2" HEX BOLT
27	12	470212	1/4 BONDED SEALING WASH, SS
28	2	359266	LEG BRACE WLD, DTS 8T 07

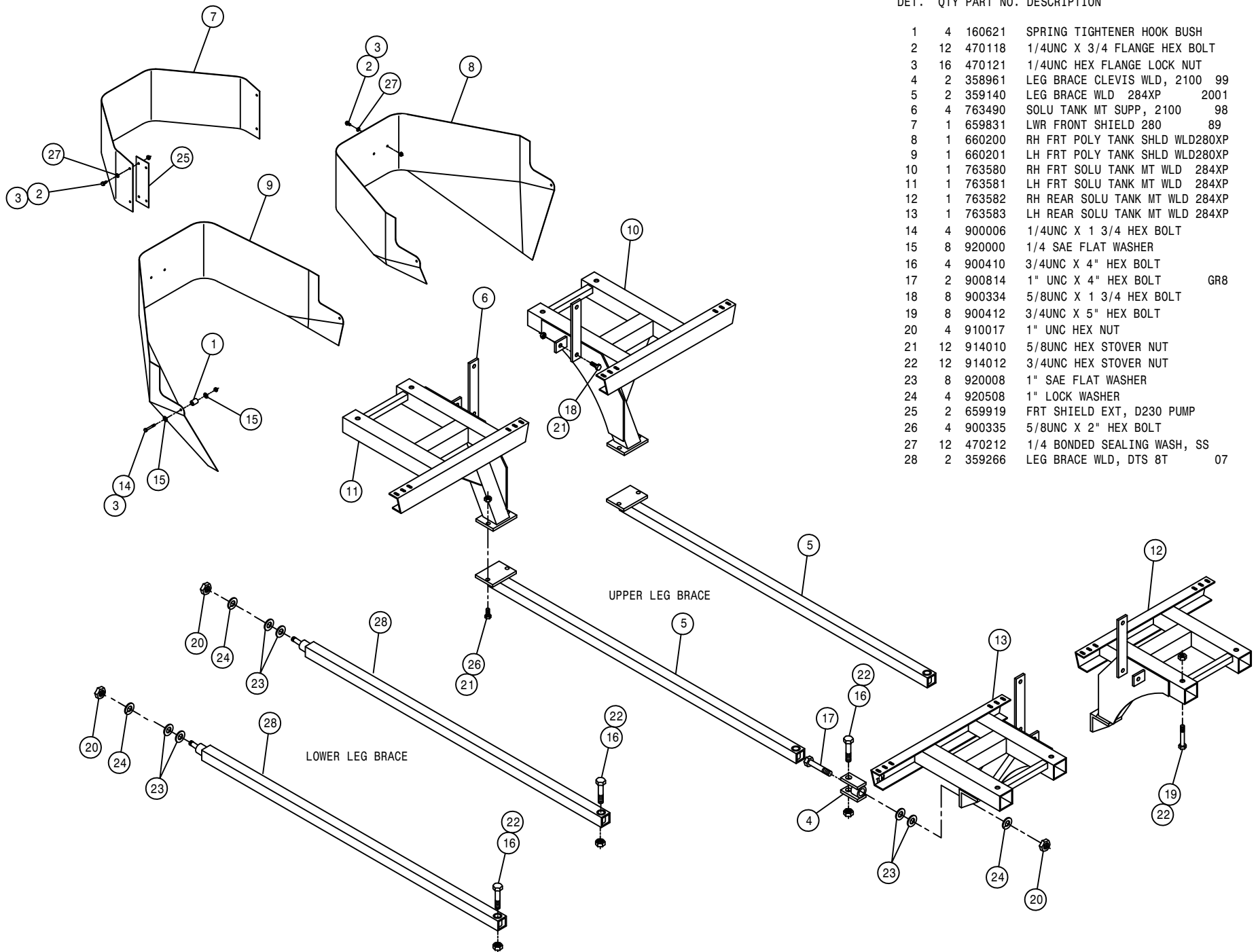

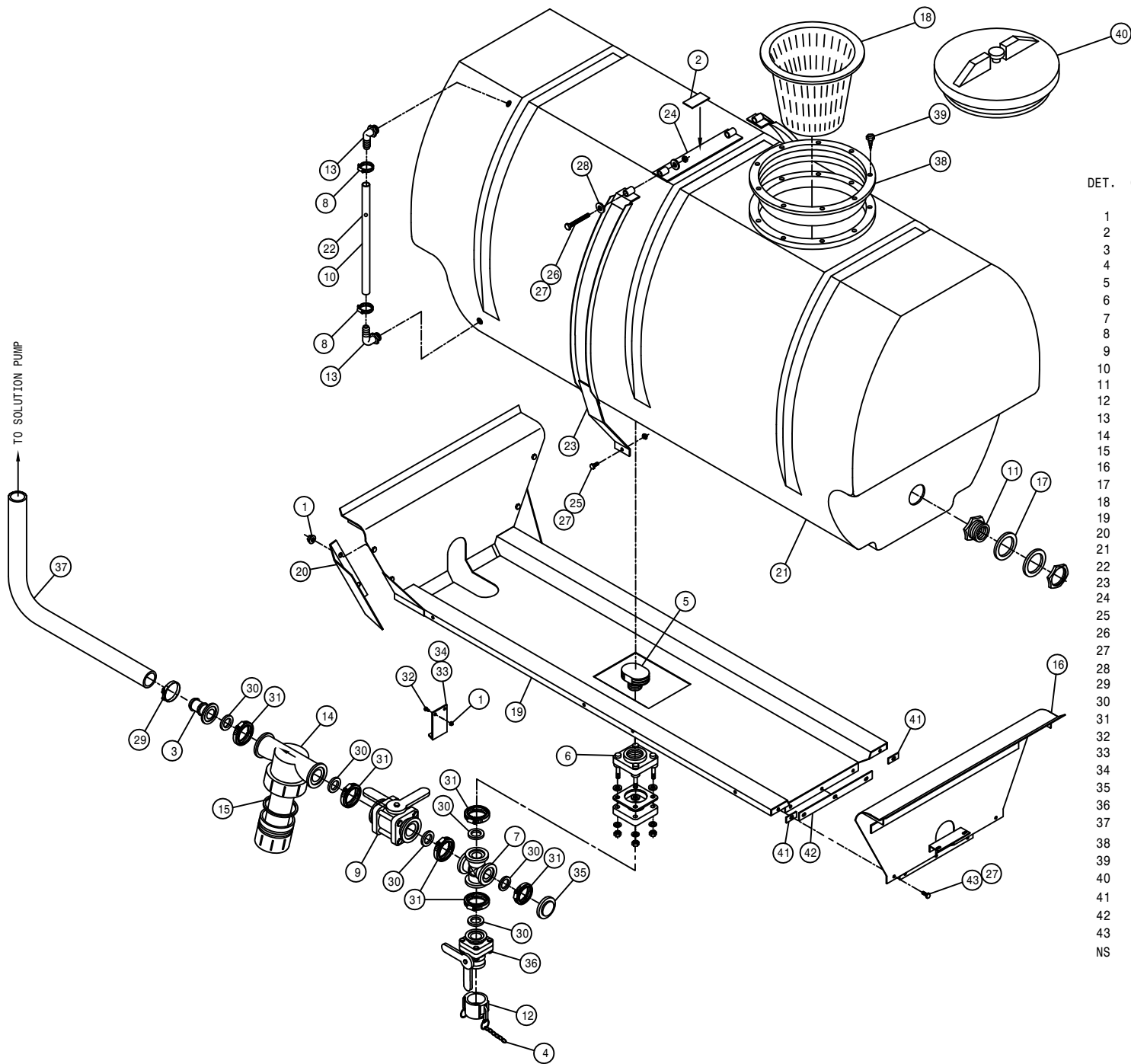

RH POLY SOLU TANK ASM,DTS8T 08

DET.	QTY	PART NO.	DESCRIPTION
	1	470121	1/4UNC HEX FLANGE LOCK NUT
	2	650850	WARNING, DANGEROUS CHEM DECAL
	3	500162	2" FLANGE-1 1/2 HOSE BARB POLY
	4	160986	CHAIN, 12.00 LONG
	5	500077	VENT CAP, 2" W/O SCREEN,POLY
	6	500179	2"FLG TANK FTG,BOTDRN BLT POLY
	7	500176	2" FLANGE CROSS POLY
	8	520069	HOSE CLAMP NO 6 STAINLESS
	9	696142	BALL VLV, 2" FLANGE
	10	601245	HOSE, 1/2 X 42 CLEAR VINYL
	11	618548	1.25 PLASTIC FTG ASSY POLYTNK
	12	690623	CAP FOR 2.00 MALE COUPLER POLY
	13	618556	1/4NPT-90-1/2 HOSE BARB,POLY
	14	690628	LINE "Y" STRAINER, 2" FLANGE
	15	690629	50 MESH SCREEN FOR 690628
	16	763340	REAR POLY CRADLE MT WLD280 90
	17	763430	1 1/4 TANK FLANGE RUBBER SEAL
	18	763431	8" STRAINER BASKET, SOLU TANK
	19	763434	POLY TANK CRADLE WELD, 284 94
	20	763436	RH SIGHT GAGE SHLD,POLY284 94
	21	763440	400 GAL GRAY POLY SOLU TANK 94
	22	763446	RED POLYPROPYLENE BALL 25/64"
	23	763454	TANK BAND WLD, 284 POLY 95
	24	763456	TANK BAND TIE WLD,284 POLY 95
	25	900129	3/8UNC X 1" SERR FLANGE BOLT
	26	906138	3/8UNC X 3 1/2 HEX BOLT FULL
	27	914004	3/8UNC HEX STOVER NUT
	28	920002	3/8 SAE FLAT WASHER
	29	520133	1.81/2.06 T-BOLT HOSE CLAMP SS
	30	500158	1 1/2" GASKET FOR 2" FLANGE
	31	500160	2" FLANGE CLAMP, S.S.
	32	470118	1/4UNC X 3/4 FLANGE HEX BOLT
	33	763363	SOLU HOSE SUPPORT 280 POLY 91
	34	470000	CABLE TIE, 21" BLACK PLASTIC
	35	500156	2" FLANGE CAP PLUG POLY
	36	696141	BALL VLV,2"FLANGE/2"MALE ADPTR
	37	601307	HOSE, 1 1/2 X 118 2F-1W EPDM
	38	763409	10" THD'D RING FOR TANK LID
	39	763410	S.S. SCREW FOR CAP RING
	40	763408	LID, THD'D W/VENT, POLY TANK
	41	763597	SOLU TANK SPACER
	42	763598	SOLU TANK SPACER
	43	900131	3/8UNC X 1 1/2 HEX BOLT
	NS	470000	CABLE TIE, 21" BLK PLASTIC

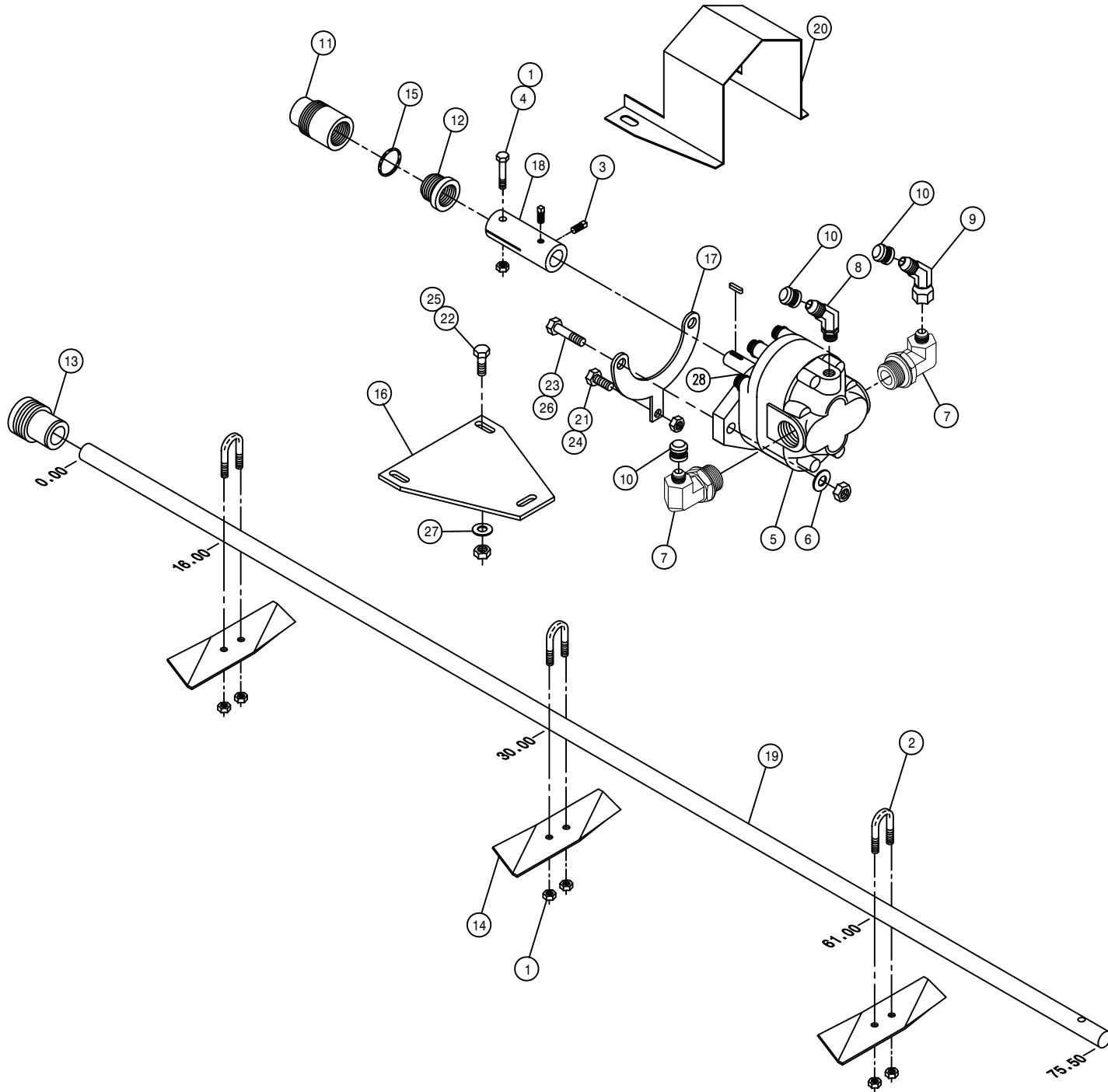

RH POLY SOLU TANK ASM,DTS8T 08

DET.	QTY	PART NO.	DESCRIPTION
1	7	470089	1/4UNC HEX NYLOC NUT, 316 SS
2	3	470092	1/4UNC-3/4ID-1 1/4 U-BOLT SS
3	2	470199	1/4UNC X 3/8 SQHD CUP SET SCR
4	1	470200	1/4UNC X 1 3/4 HEX BOLT SS
5	1	606324	GEAR MTR,1.41CI EATON
6	2	920002	3/8 SAE FLAT WASHER
7	2	618813	9/16MJIC-90-1 1/16MOR LBO
8	1	618425	9/16MJIC-45-9/16MOR LBO
9	1	618634	9/16MJIC-45-9/16FJIC SWIV LBO
10	3	629733	CAPPLUGS CAP,9/16-18FJIC,ALUM
11	1	706401	REAR AGIT SHFT BRG, NYLON
12	1	706402	AGIT SHFT GLAND NUT, NYLON
13	1	706403	FRT AGIT SHFT BRG, NYLON
14	3	763027	AGIT IMPELLER
15	1	763217	GLAND PACKING, 13 IN. LONG
16	1	763357	AGIT MTR MT PLT CES 280 91
17	1	763358	AGIT MTR MT YOKE CES 280 91
18	1	763359	AGIT MTR CPLR 280 91
19	1	763360	AGIT SHAFT 280 91
20	1	763361	AGIT CPLR SHIELD 280 91
21	1	900000	1/4UNC X 1/2 HEX BOLT
22	2	900064	5/16UNC X 3/4 HEX BOLT
23	2	900130	3/8UNC X 1 1/4 SER FLANGE BOLT
24	1	914000	1/4UNC HEX STOVER NUT
25	2	914002	5/16UNC HEX STOVER NUT
26	2	914004	3/8UNC HEX STOVER NUT
27	2	920001	5/16 SAE FLAT WASHER
28	1	606313	SHAFT SEAL

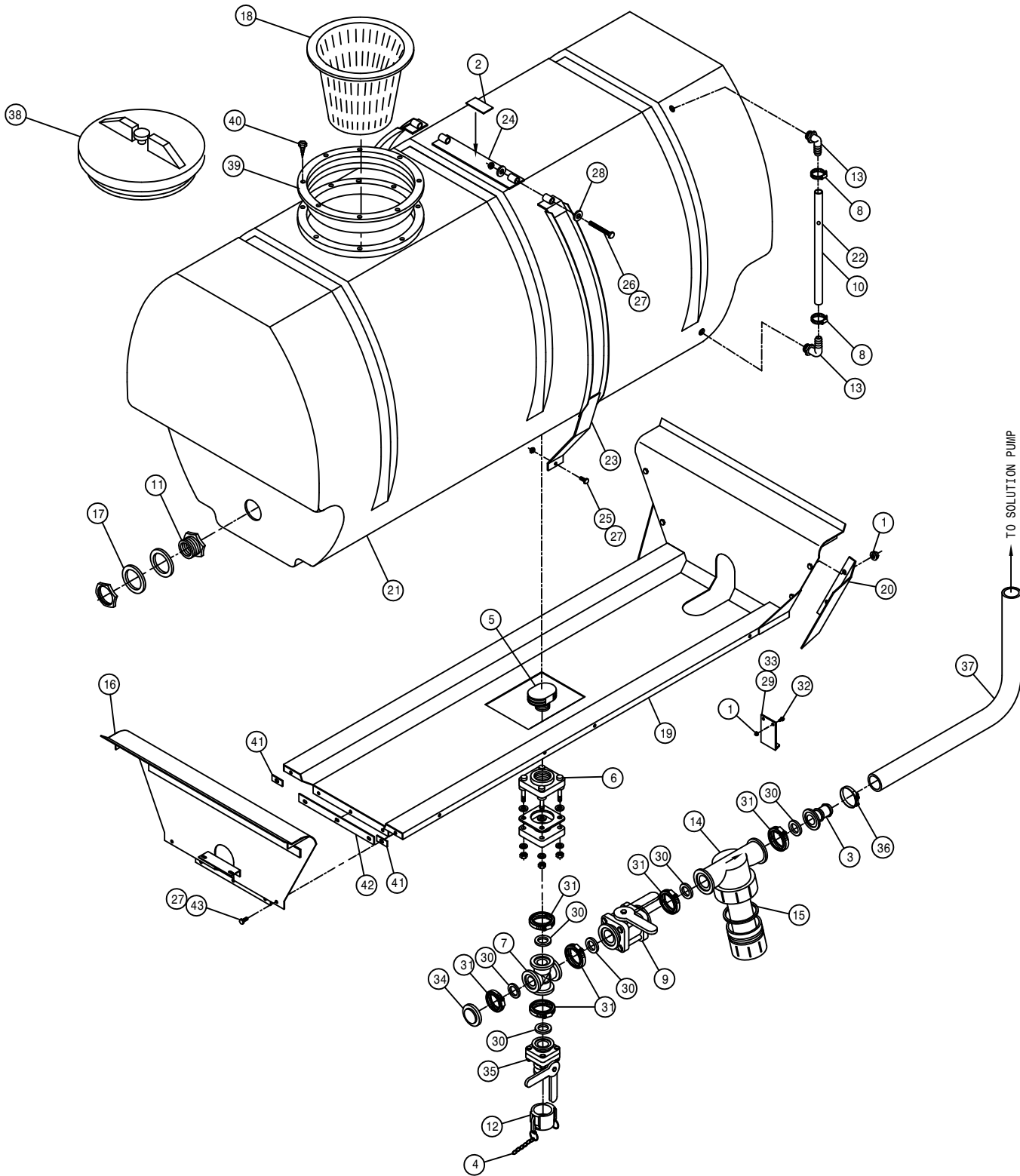

LH POLY SOLU TANK ASM,DTS8T 08

DET.	QTY	PART NO.	DESCRIPTION
	1	470121	1/4UNC HEX FLANGE LOCK NUT
	2	650850	WARNING, DANGEROUS CHEM DECAL
	3	500162	2" FLANGE-1 1/2 HOSE BARB POLY
	4	160986	CHAIN, 12.00 LONG
	5	500077	VENT CAP, 2" W/O SCREEN,POLY
	6	500179	2"FLG TANK FTG,BOTDRN BLT POLY
	7	500176	2" FLANGE CROSS POLY
	8	520069	HOSE CLAMP NO 6 STAINLESS
	9	696142	BALL VLV, 2" FLANGE
	10	601245	HOSE, 1/2 X 42 CLEAR VINYL
	11	618548	1.25 PLASTIC FTG ASSY POLYTNK
	12	690623	CAP FOR 2.00 MALE COUPLER POLY
	13	618556	1/4NPT-90-1/2 HOSE BARB,POLY
	14	690628	LINE "Y" STRAINER, 2" FLANGE
	15	690629	50 MESH SCREEN FOR 690628
	16	763340	REAR POLY CRADLE MT WLD280 90
	17	2	763430 1 1/4 TANK FLANGE RUBBER SEAL
	18	763431	8" STRAINER BASKET, SOLU TANK
	19	763434	POLY TANK CRADLE WELD, 284 94
	20	763437	LH SIGHT GAGE SHLD,POLY284 94
	21	763440	400 GAL GRAY POLY SOLU TANK 94
	22	763446	RED POLYPROPYLENE BALL 25/64"
	23	763454	TANK BAND WLD, 284 POLY 95
	24	3	763456 TANK BAND TIE WLD,284 POLY 95
	25	6	900129 3/8UNC X 1" SERR FLANGE BOLT
	26	6	906138 3/8UNC X 3 1/2 HEX BOLT FULL
	27	17	914004 3/8UNC HEX STOVER NUT
	28	12	920002 3/8 SAE FLAT WASHER
	29	1	763363 SOLU HOSE SUPPORT 280 POLY 91
	30	6	500158 1 1/2" GASKET FOR 2" FLANGE
	31	6	500160 2" FLANGE CLAMP, S.S.
	32	2	470118 1/4UNC X 3/4 FLANGE HEX BOLT
	33	1	470000 CABLE TIE, 21" BLACK PLASTIC
	34	1	500156 2" FLANGE CAP PLUG POLY
	35	1	696141 BALL VLV,2"FLANGE/2"MALE ADPTR
	36	1	520133 1.81/2.06 T-BOLT HOSE CLAMP SS
	37	1	601329 HOSE, 1 1/2 X 130 2F-1W EPDM
	38	1	763408 LID, THD'D W/VENT, POLY TANK
	39	1	763409 10" THD'D RING FOR TANK LID
	40	8	763410 S.S. SCREW FOR CAP RING
	41	2	763597 SOLU TANK SPACER
	42	1	763598 SOLU TANK SPACER
	43	5	900131 3/8UNC X 1 1/2 HEX BOLT
	NS	1	470000 CABLE TIE, 21" BLK PLASTIC

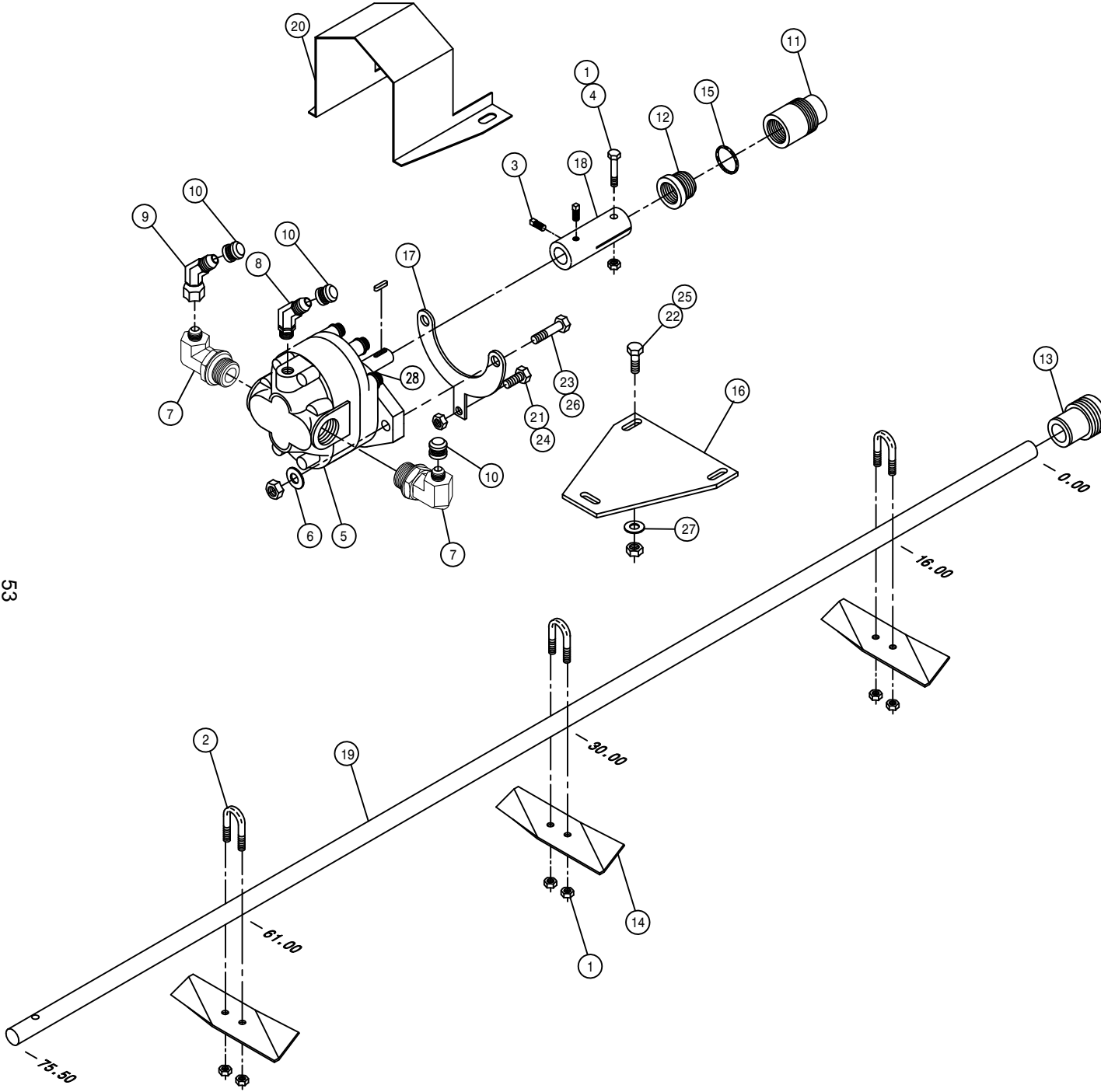

LH POLY SOLU TANK ASM, DTS8T 08

DET.	QTY	PART NO.	DESCRIPTION
1	7	470089	1/4UNC HEX NYLOC NUT, 316 SS
2	3	470092	1/4UNC-3/4ID-1 1/4 U-BOLT SS
3	2	470199	1/4UNC X 3/8 SQHD CUP SET SCR
4	1	470200	1/4UNC X 1 3/4 HEX BOLT SS
5	1	606324	GEAR MTR,1.41CI EATON
6	2	920002	3/8 SAE FLAT WASHER
7	2	618813	9/16MJIC-90-1 1/16MOR LBO
8	1	618425	9/16MJIC-45-9/16MOR LBO
9	1	618634	9/16MJIC-45-9/16FJIC SWIV LBO
10	3	629733	CAPPLUGS CAP,9/16-18FJIC,ALUM
11	1	706401	REAR AGIT SHFT BRG, NYLON
12	1	706402	AGIT SHFT GLAND NUT, NYLON
13	1	706403	FRT AGIT SHFT BRG, NYLON
14	3	763027	AGIT IMPELLER
15	1	763217	GLAND PACKING, 13 IN. LONG
16	1	763357	AGIT MTR MT PLT CES 280 91
17	1	763358	AGIT MTR MT YOKE CES 280 91
18	1	763359	AGIT MTR CPLR 280 91
19	1	763360	AGIT SHAFT 280 91
20	1	763361	AGIT CPLR SHIELD 280 91
21	1	900000	1/4UNC X 1/2 HEX BOLT
22	2	900064	5/16UNC X 3/4 HEX BOLT
23	2	900130	3/8UNC X 1 1/4 SER FLANGE BOLT
24	1	914000	1/4UNC HEX STOVER NUT
25	2	914002	5/16UNC HEX STOVER NUT
26	2	914004	3/8UNC HEX STOVER NUT
27	2	920001	5/16 SAE FLAT WASHER
28	1	606313	SHAFT SEAL

HYPRO DBS140 PUMP ASSEMBLY

DET.	QTY	PART NO.	DESCRIPTION
1	1	220025	SPROCKET,40BS16,1.25ID .25KEY
2	1	220027	SPROCKET WLD,4016-1.375-6SPL
3	1	492084	CHAIN FOR 4016 CHAIN COUPLER
4	1	500122	1 1/2" X 1"FNPT REDU CPLNGPOLY
5	3	500151	2" FLANGE TEE POLY
6	10	500158	1 1/2" GASKET FOR 2" FLANGE
7	10	500160	2" FLANGE CLAMP, S.S.
8	1	500165	2" FLANGE-1 1/2" MNPT POLY
9	1	500180	2"FLANGE-90-2"FLANGE LBO POLY
10	2	500162	2" FLANGE-1 1/2 HOSE BARB POLY
11	1	500189	2" FLANGE-90-1" HOSE BARB POLY
12	2	505114	SS PIPE ST EL 90DEG 1.00NPT
13	1	507023	SS CLOSE PIPE NIPPLE, 1.00MNPT
14	2	507730	1"-3/4"NPT REDU BUSH, SS
15	2	507731	3/8NPT PIPE PLUG, SQ HEAD, SS
16	1	507739	1" NPT PIPE TEE, SS
17	2	520090	HOSE CLAMP NO 16 STAINLESS
18	1	601681	HOSE, 1 X 8 2BR BLK EPDM
19	1	618171	7/8MOR-3/4FOR ADPTR
20	1	618183	3/4MJIC-90-7/8MOR LBO
21	1	618241	3/4MJIC-90-3/4MOR LBO
22	1	699705	RELIEF VLV,3/4NPT,400PSI,HYPRO
23	1	650851	CAUTION, SHIELD PROTECT DECAL
24	1	500123	3/4NPT-1"HOSE BARB, POLY
25	1	690364	D150-D230 PUMP CPLR SHLD
26	1	690885	HYPRO DBS140 PUMP
27	1	690886	PUMP MT PLT, HYPRO DBS140
28	1	690887	MTR MT WLD, HYPRO DBS140
29	1	690889	1"FNPT ADAPTER, HYPRO DBS140
30	1	695985	CHAR LYNN 2000 HYD MTR, 6.1CI
31	2	690893	SOLU PUMP MT PLATE SUPP,284TXP
32	1	714561	1.00NPT-1.25 HOSE BARB
33	1	520087	HOSE CLAMP NO 20 STAINLESS
34	2	900003	1/4UNC X 1" HEX BOLT
35	12	900129	3/8UNC X 1" HEX BOLT
36	4	900264	1/2UNC X 1 1/4 HEX BOLT
37	2	900265	1/2UNC X 1 1/2 HEX BOLT
38	2	914000	1/4UNC HEX STOVER NUT
39	12	914004	3/8UNC HEX STOVER NUT
40	6	914008	1/2UNC HEX STOVER NUT
41	8	920002	3/8 SAE FLAT WASHER
42	4	920004	1/2 SAE FLAT WASHER
43	1	500172	2" FLANGE-1" HOSE BARB POLY
44	1	520132	1.62/1.87 T-BOLT HOSE CLAMP SS
45	2	520133	1.81/2.06 T-BOLT HOSE CLAMP SS
46	1	601617	HOSE, 1 1/4 X 60 2BR BLK EPDM
47	1	690894	SHAFT GUARD WLD, 284TXP 04
48	2	473827	8MM-1.25 X 20MM HEX BOLT
49	2	473849	8MM FLAT WASHER
50	2	696265	VALVE,KZCO 2"SPF ELEC W/WP
51	1	472024	STEP KEY,.312 X .250 X 1.25 LG

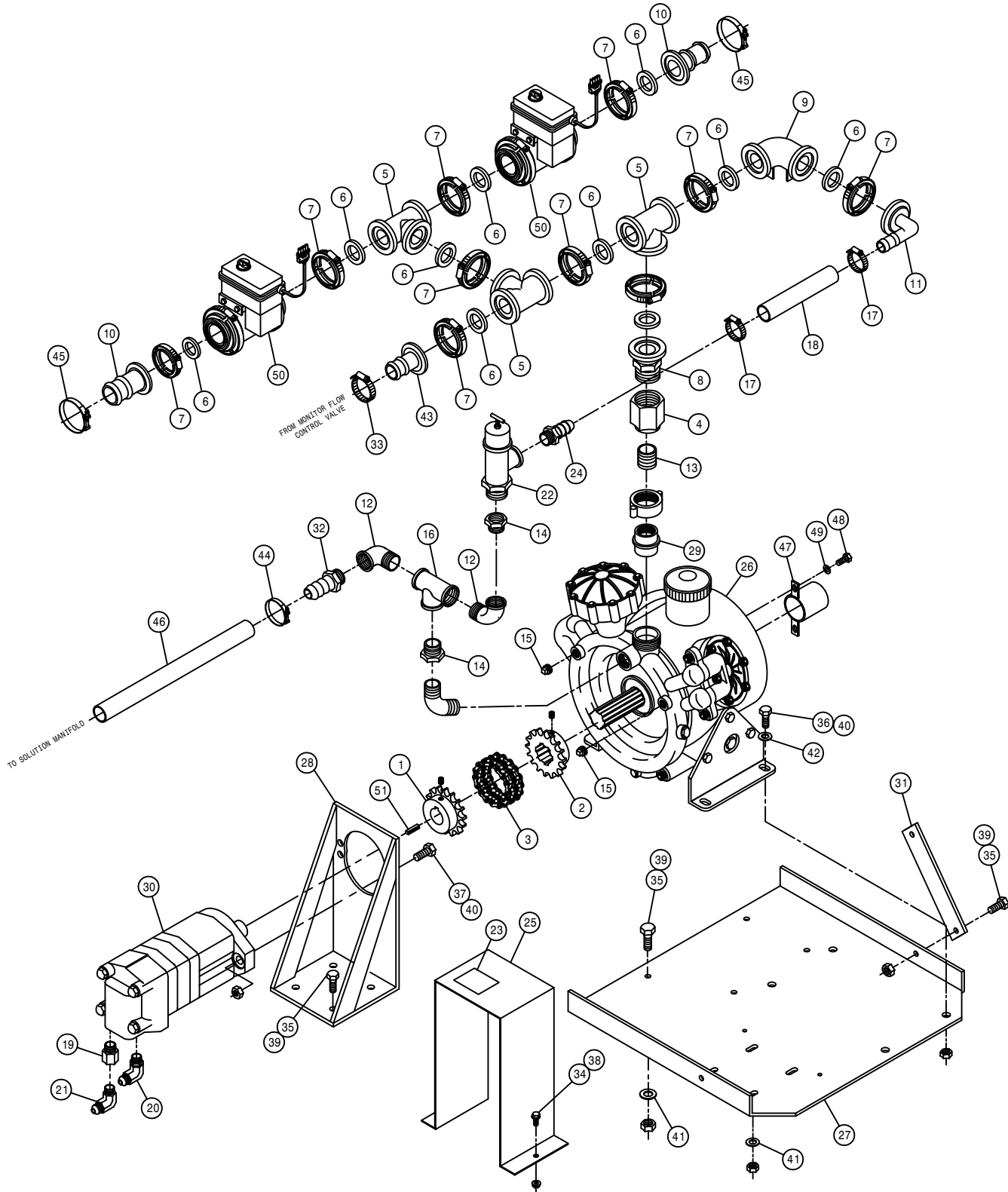

MONITOR FITTING ASSEMBLY

DET. QTY PART NO. DESCRIPTION

1	1	601602	HOSE, 1 X 68 2BR BLK EPDM
2	4	470118	1/4UNC X 3/4 FLANGE HEX BOLT
3	2	505200	BLK PIPE ST EL 90DEG 1.00NPT
4	3	505201	CLOSE NIPPLE 1.00NPT
5	1	506005	1 1/4 TO 1 RED BUSH BLK MAL
6	2	506105	BLK PIPE TEE 1.25NPT
7	1	165010	RFM60 FLO METER MT,STS 10T 05
8	1	520099	HOSE CLAMP NO 40 STAINLESS
9	1	690406	CONTROL VALVE, 1" POLY, RAVEN
10	1	696129	BALL VALVE, 1"FNPT 300PSI
11	2	500024	1"NPT-90-1"HOSE BARB, POLY
12	4	715660	HOSE BARB 1 1/4NPT X 1 1/4
13	7	520087	HOSE CLAMP NO 20 STAINLESS
14	1	691013	RFM 60S FLOW METER,RAVEN,STD
15	1	165012	CTRL VLV FTG SUPP WLD STS8
16	1	601294	HOSE, 1 1/4 X 96 2BR BLK EPDM
17	1	601683	HOSE, 1 1/4 X 6 2BR BLK EPDM
18	1	601617	HOSE, 1 1/4 X 60 2BR BLK EPDM
19	1	505101	BLK PIPE TEE 1.00NPT
20	1	714560	1NPT X 1 HOSE BARB
21	1	506200	CLOSE NIPPLE 1.25NPT
22	1	500052	1 1/4 X 1NPT REDU NIPPLE,POLY
23	1	696162	1" ELECT BALL VLV, 344AEC-2-1
24	1	601657	HOSE, 1 X 18 2BR BLK EPDM
25	1	507015	RED BUSH 1.50NPT - 1.25FNPT
26	4	470121	1/4UNC HEX FLANGE LOCK NUT

\* PARTS FOR ASSEMBLY 691014

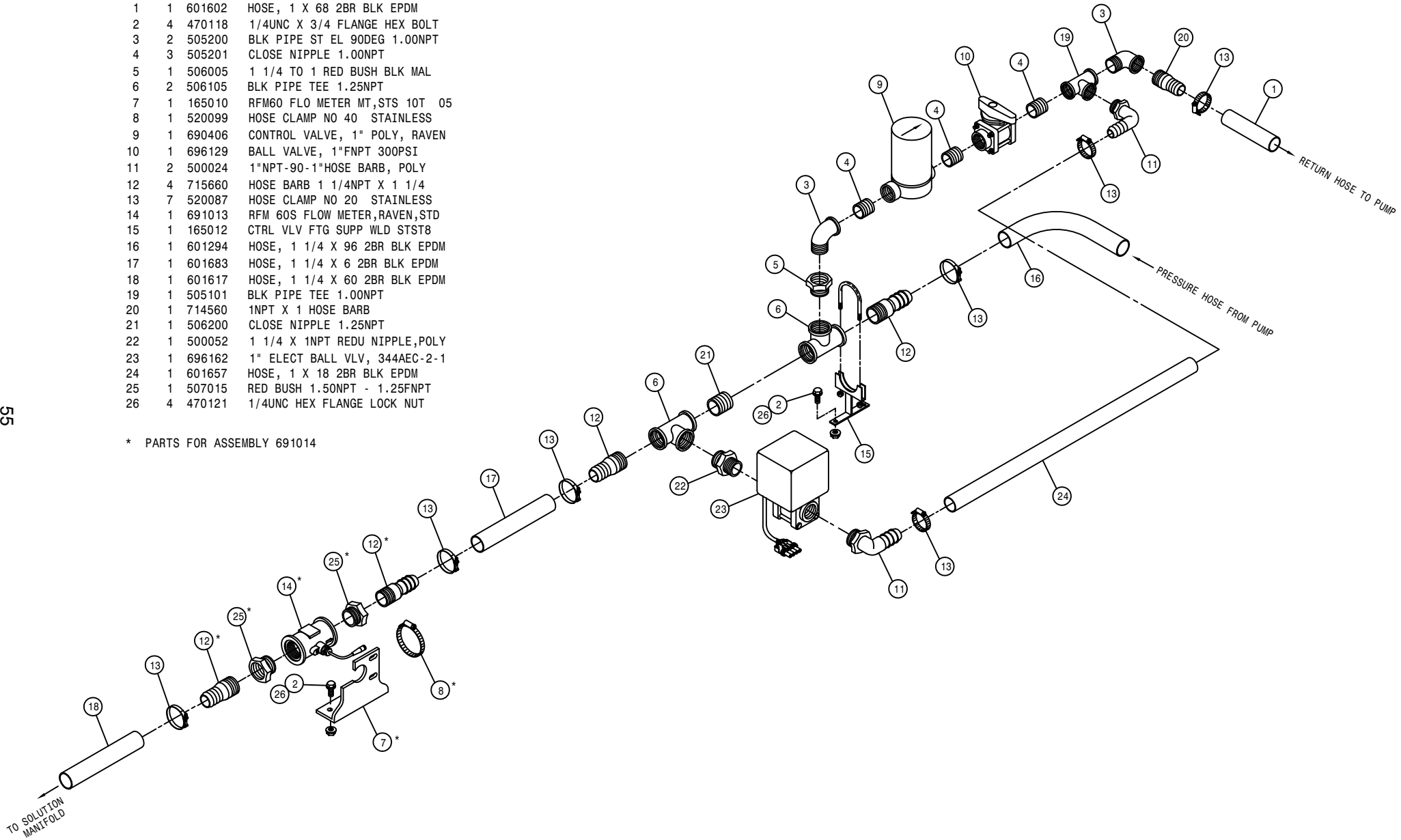

SOLUTION MANIFOLD ASSEMBLY

DET. QTY PART NO. DESCRIPTION

DET.	QTY	PART NO.	DESCRIPTION
1	2	470136	3/8UNC-3 1/16ID-3 SQ U-BOLT
2	4	914004	3/8UNC HEX STOVER NUT
3	1	506409	BLK PIPE ST EL 45DEG 1.25NPT
4	2	618401	3/8MNPT X 3/8 HOSE INSERT, RIG
5	3	696261	VALVE,3-SECT KZCO BARB,PACKARD
6	1	503010	RED BUSH 1/2MNPT-3/8FNPT,STEEL
7	1	601337	HOSE, 3/4 X 96 2BR BLK EPDM
8	1	601340	HOSE, 3/4 X 276 2BR BLK EPDM
9	1	715660	HOSE BARB 1 1/4NPT X 1 1/4
10	1	507015	RED BUSH 1.50NPT - 1.25FNPT
11	1	601339	HOSE, 3/4 X 216 2BR BLK EPDM
12	2	472349	1/4 X 3/4 20THD-IN TEK TYPE
13	1	601660	HOSE, 3/8 X 175 2BR BLK EPDM
14	1	341520	PRESSURE GAUGE MT WLD 8240X11
15	1	501450	BLK PIPE ST EL 90DEG .25NPT
16	1	503000	RED BUSH 1/2 TO 1/4 BLK MAL
17	1	701350	PRESS GAUGE 300LB BOT FILL
18	4	520080	HOSE CLAMP NO 10 STAINLESS
19	6	520090	HOSE CLAMP NO 16 STAINLESS
20	1	520132	1.62/1.87 T-BOLT HOSE CLAMP SS

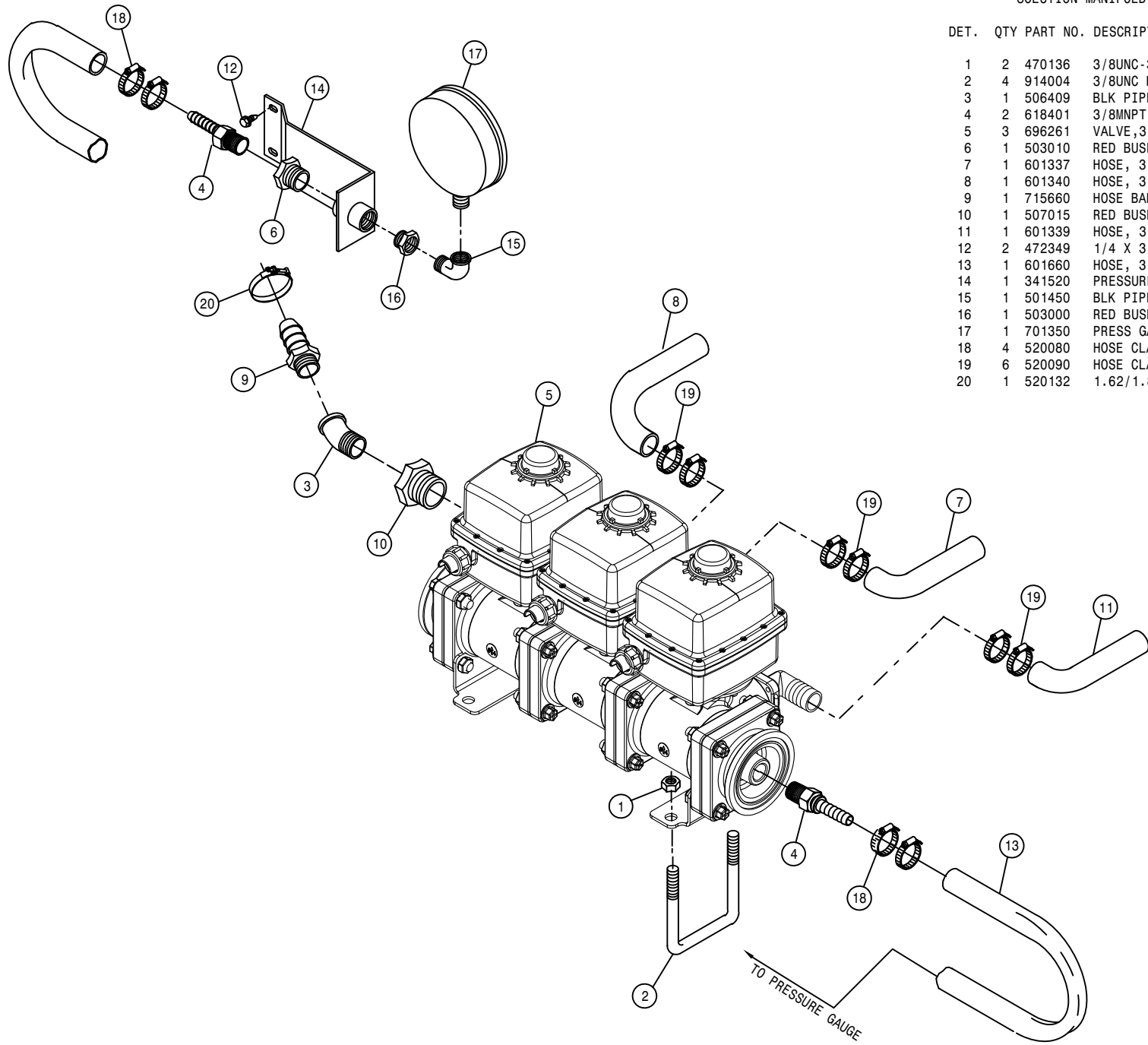



BOOM CONTROL VALVE ASSEMBLY

DET. QTY PART NO. DESCRIPTION

DET.	QTY	PART NO.	DESCRIPTION
1	28	473802	# 8 INT TOOTH STAR WASHER
2	1	605615	HYD FILTER, INLINE 25M 9/16FOR
3	1	606102	BOOM VLV, X11/284/2100 PWRSYS03
4	1	618115	9/16MJIC-90-3/4MOR LBO
5	5	618119	9/16MJIC-90-9/16MOR LBO
6	5	618126	9/16MJIC-9/16MOR ADPTR
7	1	618241	3/4MJIC-90-3/4MOR LBO
8	1	618444	9/16MOR RUN TEE-9/16MJIC
9	2	618618	9/16MJIC-90-9/16FJIC SWIV LBO
10	1	618692	3/4FJIC SWIV-9/16MOR ADPTR
11	1	605616	ELEMENT, 25M HYD FILTER 605615
12	1	605617	SPRING KIT, HYD FILTER 605615
13	2	900146	3/8UNC X 5 3/4 HEX BOLT
14	2	914004	3/8UNC HEX STOVER NUT
15	2	610185	9/16MOR PLUG, HEX HEAD
16	1	618486	9/16FJIC SW RUN TEE-9/16MJIC
17	2	614763	9/16MJIC-9/16MOR, .042ORF ADPTR
18	6	606145	SOLENOID, 4W3P #08, (606103/104)
19	6	606168	SEAL KIT FOR 606145 SOLENOID
20	1	606144	COIL, #10, 12VDC, DUAL STUDS
21	1	606147	MAIN #10 SOLENOID FOR 606102
22	1	606169	SEAL KIT FOR 606147 SOLENOID
23	1	606146	MAIN #8 SOLENOID FOR 606102
24	1	606167	SEAL KIT FOR 606146 SOLENOID
25	13	606142	COIL, #08, 12VDC, DUAL STUDS
26	1	610462	GASKET FOR 610447 ARROW FILT

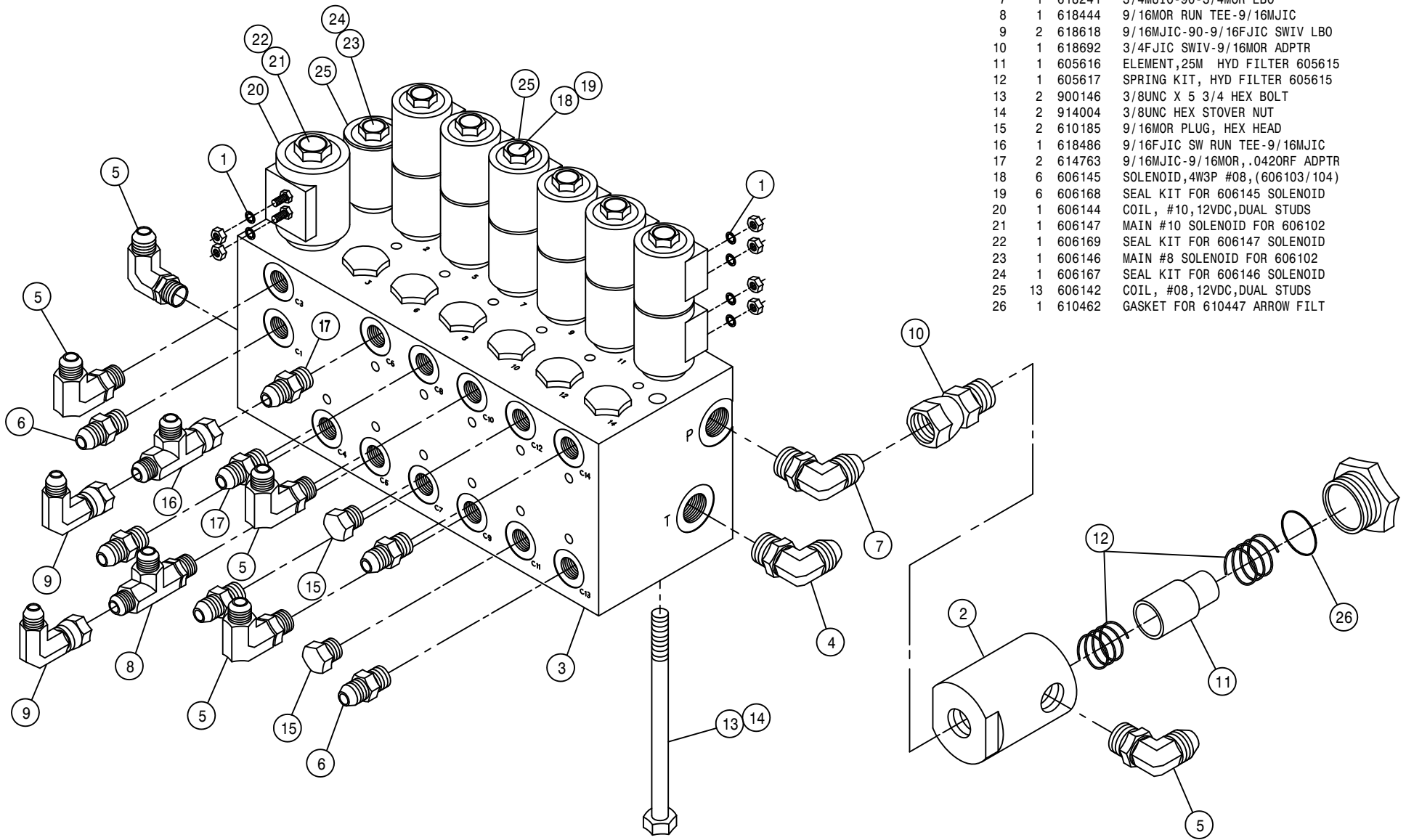

LIFTARM ASSEMBLY

DET. QTY PART NO. DESCRIPTION

DET.	QTY	PART NO.	DESCRIPTION
1	2	160471	LWR LIFT ARM WLD 8540-8250 87
2	1	164685	RH LIFT ARM MT WLD, 284XP 2001
3	1	164686	LH LIFT ARM MT WLD, 284XP 2001
4	12	160691	BUSH LIFT ARM LONG 470
5	9	470287	TUBE CLAMP, .375-.375 (PAIR)
6	1	164650	UPPER LIFT ARM WLD,254 X-11 01
7	12	471005	1/4 28 X 1/2 GREASE ZERK
8	3	900013	1/4UNC X 3 3/4 HEX BOLT
9	2	621207	TRANSOM LIFT CYL ASSY 284-2101
10	3	914000	1/4UNC HEX STOVER NUT
11	10	900334	5/8UNC X 1 3/4 HEX BOLT
12	4	900342	5/8UNC X 4" HEX BOLT
13	8	900343	5/8UNC X 4 1/2 HEX BOLT
14	30	914010	5/8UNC HEX STOVER NUT
15	1	615786	LIFT RAISE HYD TUBE ASSY X-11
16	1	615787	LIFT LOWER HYD TUBE ASSY X-11
17	1	615789	LEVEL LOWER HYD TUBE ASSY X-11
18	1	615788	LEVEL RAISE HYD TUBE ASSY X-11
19	2	618019	9/16MJIC UNION TEE
20	2	618618	9/16MJIC-90-9/16FJIC SWIV LBO
21	1	615791	RH FOLD LOWER HYD TUBE ASSYX11
22	1	615790	RH FOLD RAISE HYD TUBE ASSYX11
23	4	619010	9/16MJIC UNION
24	8	900338	5/8UNC X 3" HEX BOLT
25	2	164684	LIFT ARM MT KEEPER WLD 284XP

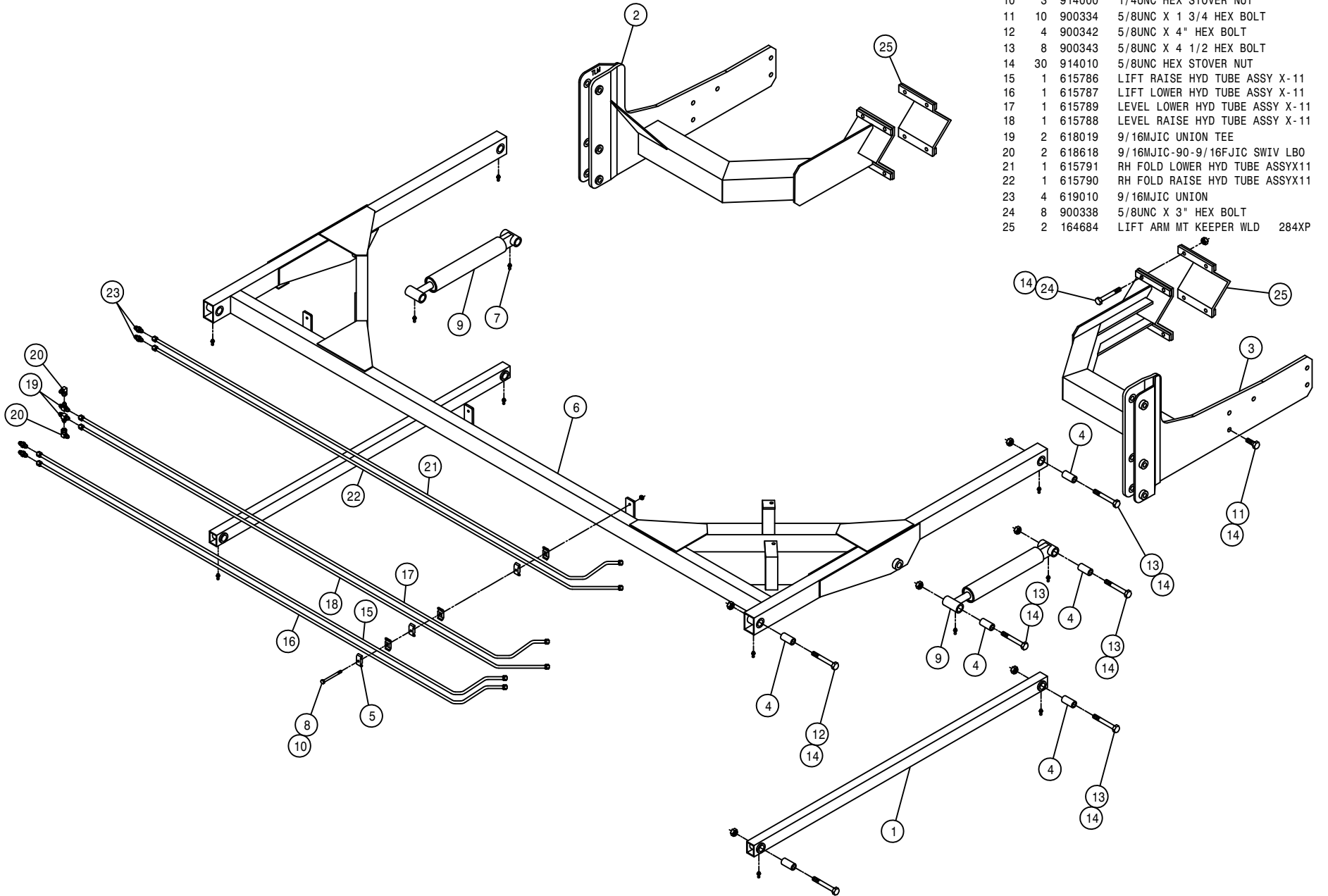

TRANSOM ASSEMBLY

DET. QTY PART NO. DESCRIPTION

DET.	QTY	PART NO.	DESCRIPTION
1	2	160429	FEEDER HOSE SUPPORT SPRING MT
2	2	160691	BUSH LIFT ARM LONG 470
3	2	164124	NOZL MT TUBE,254X-11, 284W 96
4	4	164125	NOZL MT TUBE HANGER CHAN 96
5	2	164823	BRKAWAY PIVOT BUSH,DTS 8/10 05
6	2	164128	LEVEL CYL PIVOT BRKT WLD 96
7	2	164824	BOOM BREAKAWAY WLD,284/2101 05
8	4	629735	CAPLUG, 1 1/4" SQ, BLACK POLY
9	4	470136	3/8UNC-3 1/16ID-3 SQ U-BOLT
10	4	164264	5/8UNC X 3" EYE BOLT
11	6	471005	1/4 28 X 1/2 GREASE ZERK
12	8	473973	.31UNC-1.31ID-2.0 SQ U-BOLT SS
13	2	900852	1" UNC-4 3/4 HHCS,1 1/4THD GR8
14	4	910010	5/8UNC HEX NUT
15	16	914002	5/16UNC HEX STOVER NUT
16	8	914004	3/8UNC HEX STOVER NUT
17	2	470118	1/4UNC X 3/4 FLANGE HEX BOLT
18	12	914010	5/8UNC HEX STOVER NUT
19	8	920005	5/8 SAE FLAT WASHER
20	2	900848	5/8UNC X 4 3/4 HEX BOLT GR8
21	2	164830	BOOM PIVOT PIN,1.00 X 13.31 05
22	4	470117	COTTER PIN 3/16 1 3/4 SQ CUT
23	2	482000	SPRING,.930D X 8.5LG,.072WIRE
24	2	520126	CUSH HOSE CLAMP 2IN X 5/8W
25	2	621210	BOOM LEVEL CYL ASSY 04
26	2	621208	BOOM HINGE FOLD CYL ASSY 04
27	4	900829	5/8UNC X 4" HEX BOLT GR8
28	2	470121	1/4UNC HEX FLANGE LOCK NUT
29	2	900844	5/8UNC X 2 3/4 HEX BOLT GR8
30	4	483032	1 1/2 X 1" X .134TH MACH WASH
31	1	164816	TRANSOM WLD, DTS 8T 05
32	2	471023	GREASE ZERK 1/4-28 X 45
33	2	621211	ACCUMULATOR CYL ASSY,60 BOOM
34	4	520099	HOSE CLAMP NO 40 STAINLESS
35	2	914016	1" UNC HEX STOVER NUT

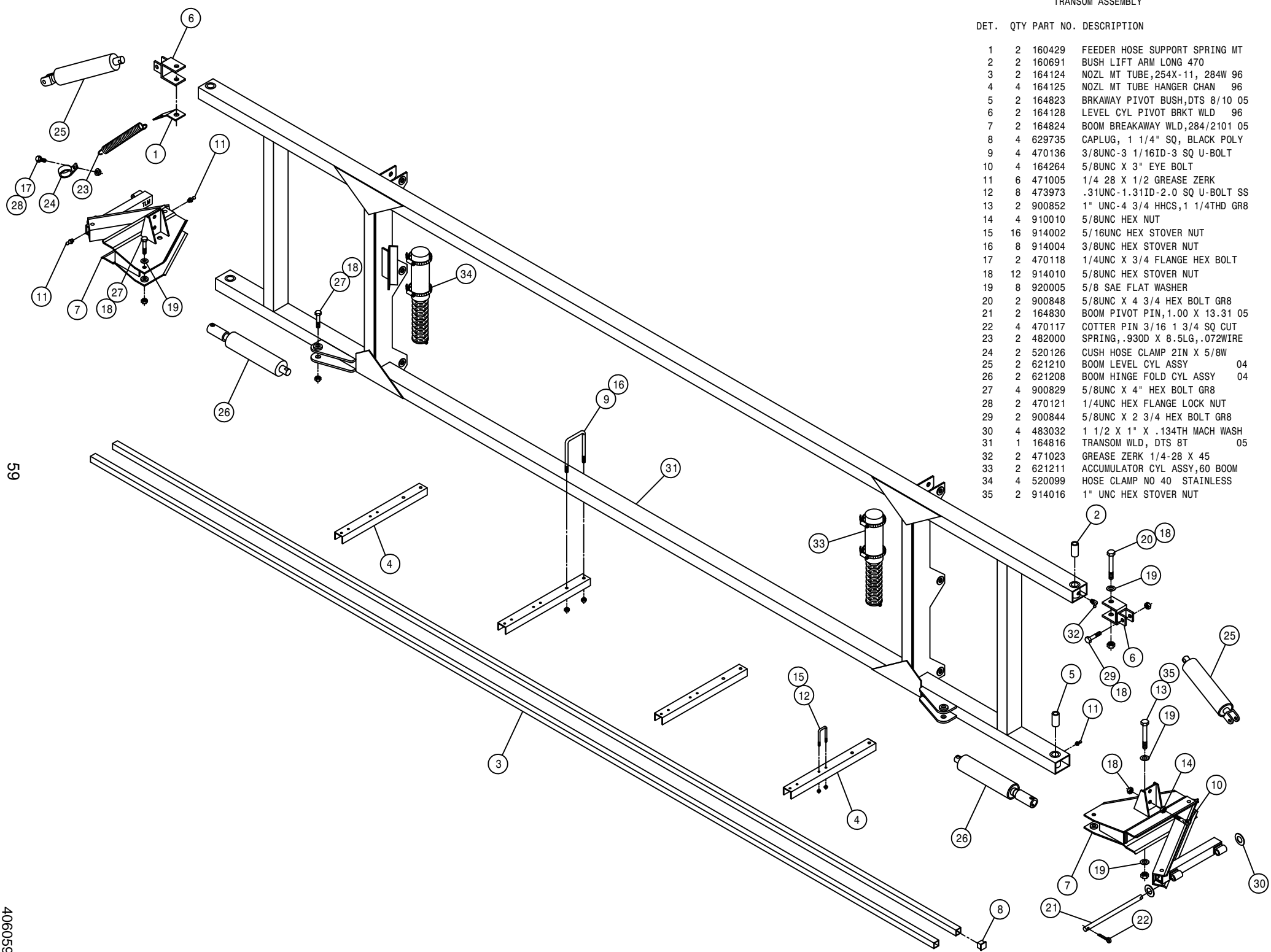

59

406059

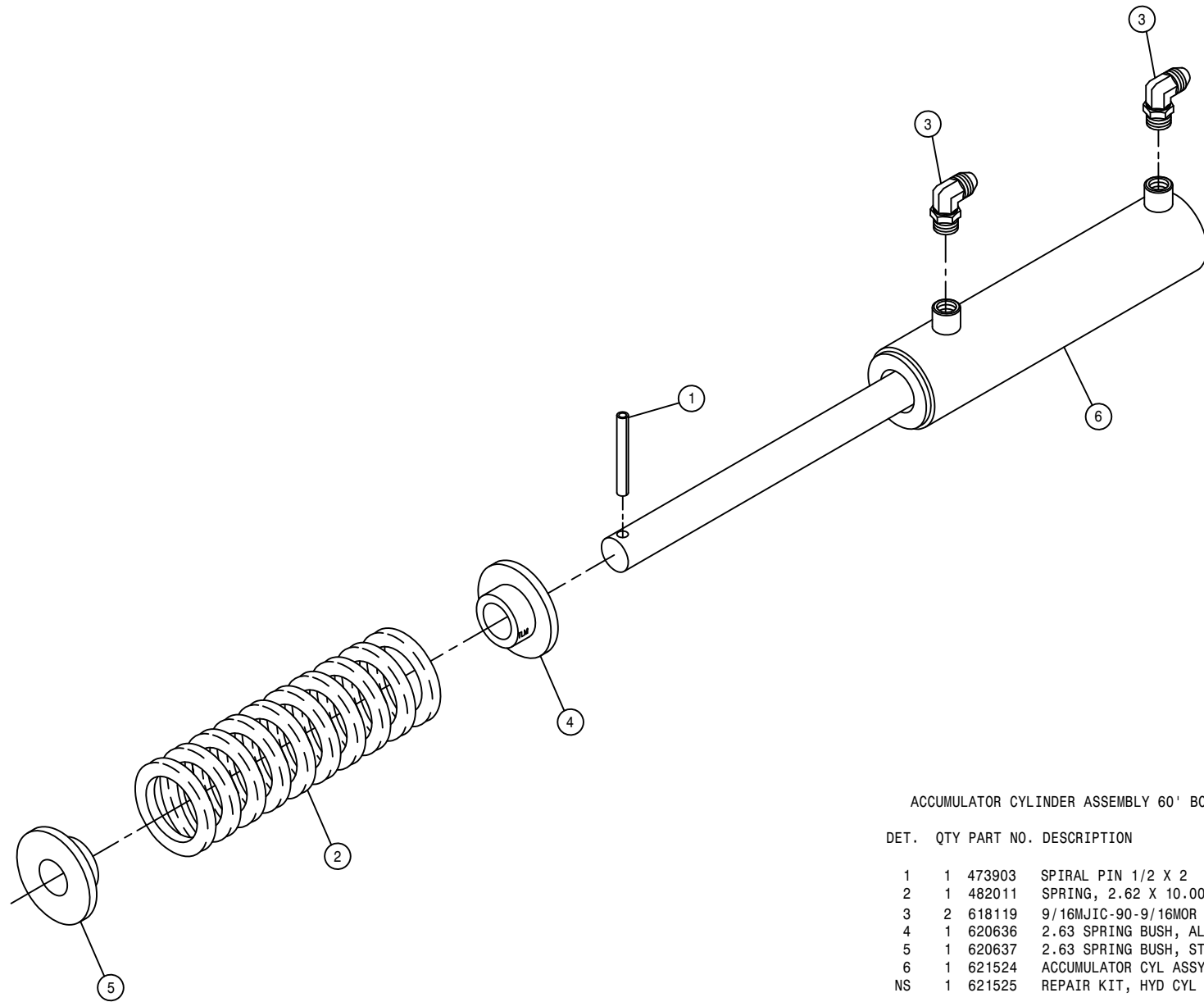

ACCUMULATOR CYLINDER ASSEMBLY 60' BOOM

DET.	QTY	PART NO.	DESCRIPTION	
	1	473903	SPIRAL PIN 1/2 X 2	640
	1	482011	SPRING, 2.62 X 10.00 COMPRSN	
	2	618119	9/16MJIC-90-9/16MOR LBO	
	1	620636	2.63 SPRING BUSH, ALUM	96
	1	620637	2.63 SPRING BUSH, STEEL	96
	1	621524	ACCUMULATOR CYL ASSY	
NS	1	621525	REPAIR KIT, HYD CYL 621524	

NOTE: 621211 - ACCUMULATOR CYLINDER ASSEMBLY

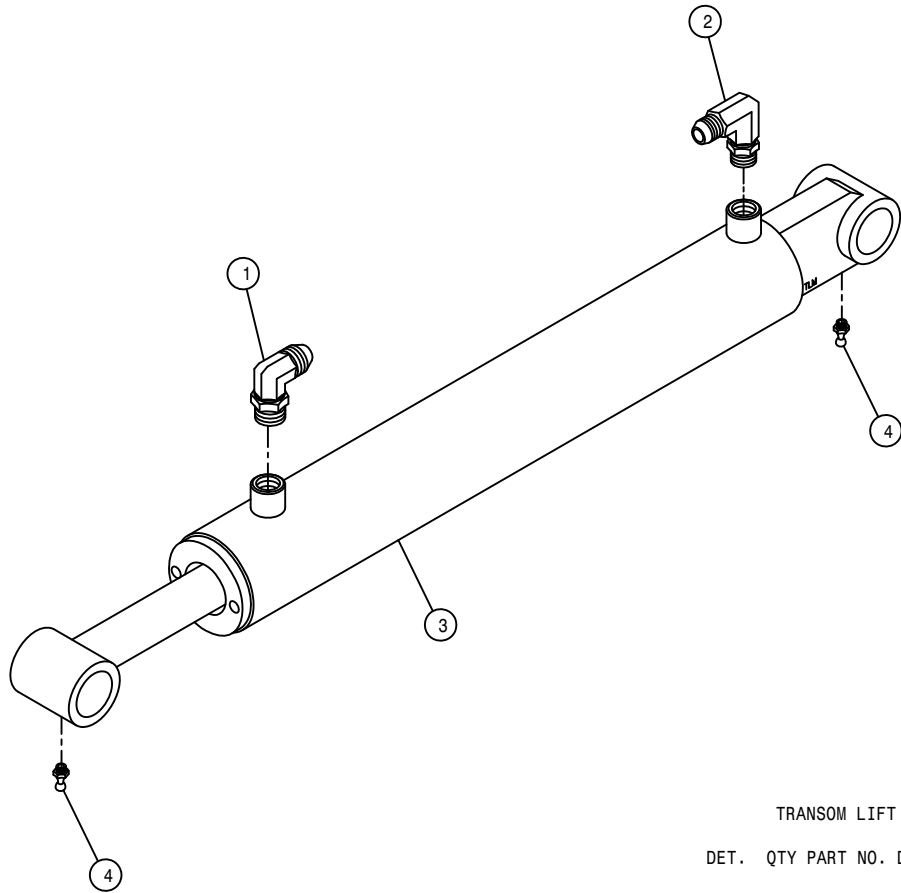

TRANSOM LIFT CYLINDER ASSEMBLY

DET.	QTY	PART NO.	DESCRIPTION
1	1	618119	9/16MJIC-90-9/16MOR LBO
2	1	618689	9/16MOR-90-9/16MJ .042 CHK VLV
3	1	621518	TRANSOM LIFT CYL ASSY
4	2	471005	1/4 28 X 1/2 GREASE ZERK
NS	1	621519	REPAIR KIT, HYD CYL 621518

NOTE: 621207 - TRANSOM LIFT CYLINDER ASSEMBLY WITH FITTINGS

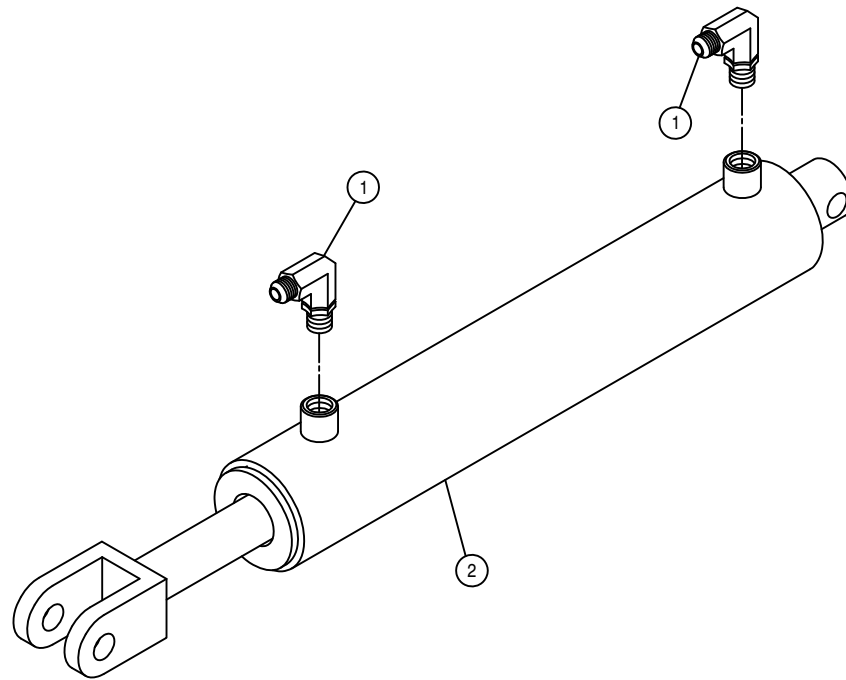

BOOM LEVEL CYLINDER ASSEMBLY

DET. QTY PART NO. DESCRIPTION

1	2	618119	9/16MJIC-90-9/16MOR LBO
2	1	621522	BOOM LEVEL CYL ASSY
NS	1	621523	REPAIR KIT, HYD CYL 621522

NOTE: 621210 - BOOM LEVEL CYLINDER ASSEMBLY WITH FITTINGS

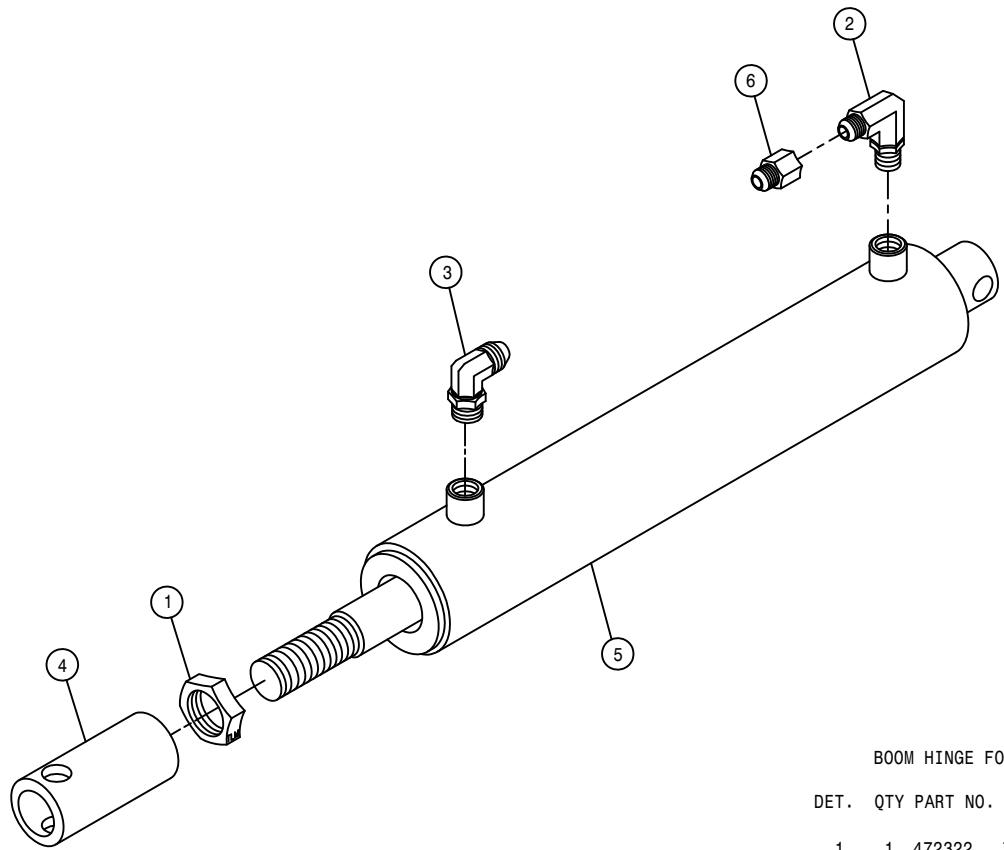

BOOM HINGE FOLD CYLINDER ASSEMBLY

DET.	QTY	PART NO.	DESCRIPTION
	1	472322	7/8-14 UNF HEX JAM NUT
	1	618119	9/16MJIC-90-9/16MOR LBO
	1	618688	9/16MOR-90-9/16MJ .025 CHK VLV
	1	620653	FOLD CYL ADJ SLEEVE 97
	1	621520	BOOM HINGE FOLD CYL ASSY
	1	618733	9/16JIC .042 ORIFICE ADPTR
NS	1	621521	REPAIR KIT, HYD CYL 621520

NOTE: 621208 - BOOM HINGE FOLD CYLINDER ASSEMBLY WITH FITTINGS

INNER BOOM ASSEMBLY

DET. QTY PART NO. DESCRIPTION

DET.	QTY	PART NO.	DESCRIPTION	
1	1	164831	BOOM WLD, INNER SECTION	05
2	1	164227	BOOM BALL JOINT BUSH	96
3	2	164263	SWIVEL, 5/8 BOOM EYEBOLT	
4	2	164265	5/8UNC X 7 1/2 EYE BOLT	
5	2	482014	SPRING, 3.25 X 11.50 EXTENSION	
6	4	910010	5/8UNC HEX NUT	
7	1	471028	GREASE ZERK, 1/4-28 90DEG	
8	1	900844	5/8UNC X 2 3/4 HEX BOLT GR8	
9	1	914010	5/8UNC HEX STOVER NUT	
10	2	164275	NOZL MT WLD	96
11	2	900007	1/4UNC X 2" HEX BOLT	
12	2	914000	1/4UNC HEX STOVER NUT	

NOTE: (\*) USED WITH SPECIFIC NOZZLE SPACING.

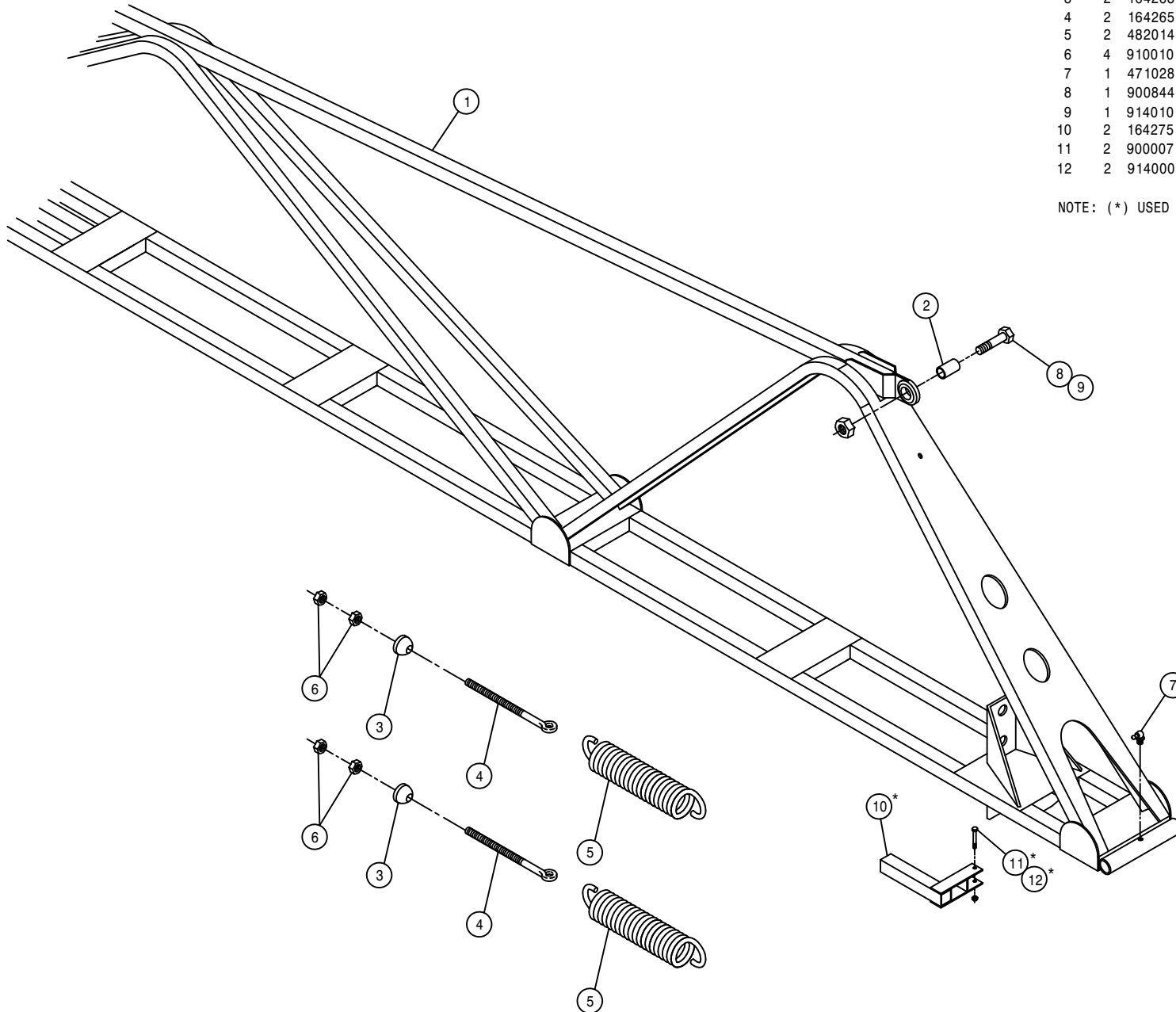



60' BOOM HINGE PIVOT ASSEMBLY

DET. QTY PART NO. DESCRIPTION

1	1	164205	BOOM WLD, 60' OUTER SECT	96
2	1	164231	BOOM PIN, 1.00 X 11.75	96
3	2	470162	COTTER PIN 3/16 X 1 1/2 SQ CUT	
4	1	472276	CLEVIS PIN, 1.00 X 2.00	PLT
5	1	611016	HAIR PIN #6	
6	2	900128	3/8UNC X 3/4 HEX BOLT	
7	2	914004	3/8UNC HEX STOVER NUT	
8	2	438302	HOSE SUPPORT RING WLD	
9	1	471028	GREASE ZERK, 1/4-28 90DEG	

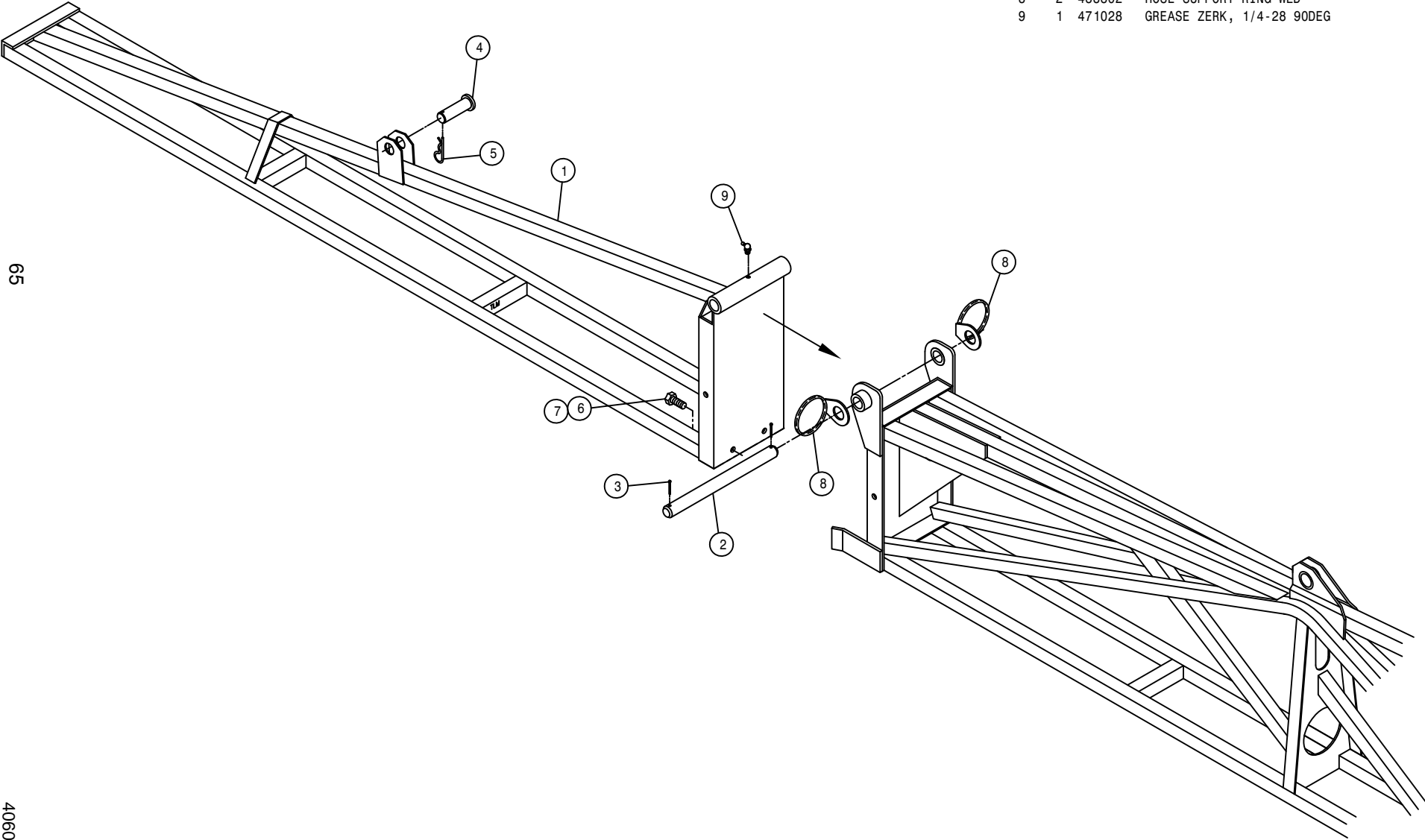

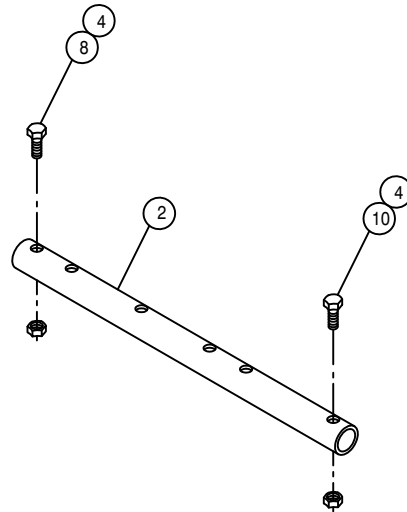
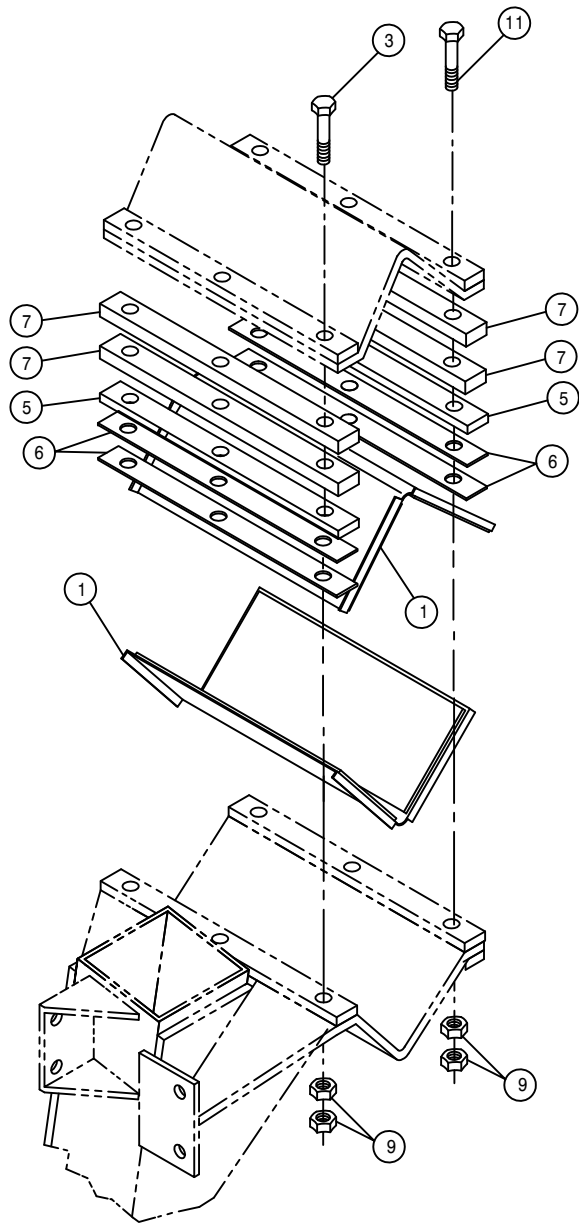

TREAD ADJUSTMENT ASSEMBLY

DET. QTY PART NO. DESCRIPTION

1	8	359294	TREAD ADJ XMBR BEARING ASSY 05	
2	4	358944	TREAD ADJ CYL EXT, 154" 2100 98	
3	12	900838	5/8UNF X 4" HEX BOLT GR8	
4	12	914008	1/2UNC HEX STOVER NUT	
5	8	358769	.250 LEG MT SHIM, 284T	94
6	16	358768	.037 LEG MT SHIM, 284T	94
7	16	358766	.375 LEG MT SPACER, 284T	94
8	4	900268	1/2UNC X 2 1/2 HEX BOLT	
9	48	914811	5/8UNF HEX NUT GR8	
10	4	900267	1/2UNC X 2" HEX BOLT	
11	12	900853	5/8UNF X 4 1/2 HEX BOLT GR8	

NOTE: QUANTITY LISTED IS FOR ONE MACHINE.

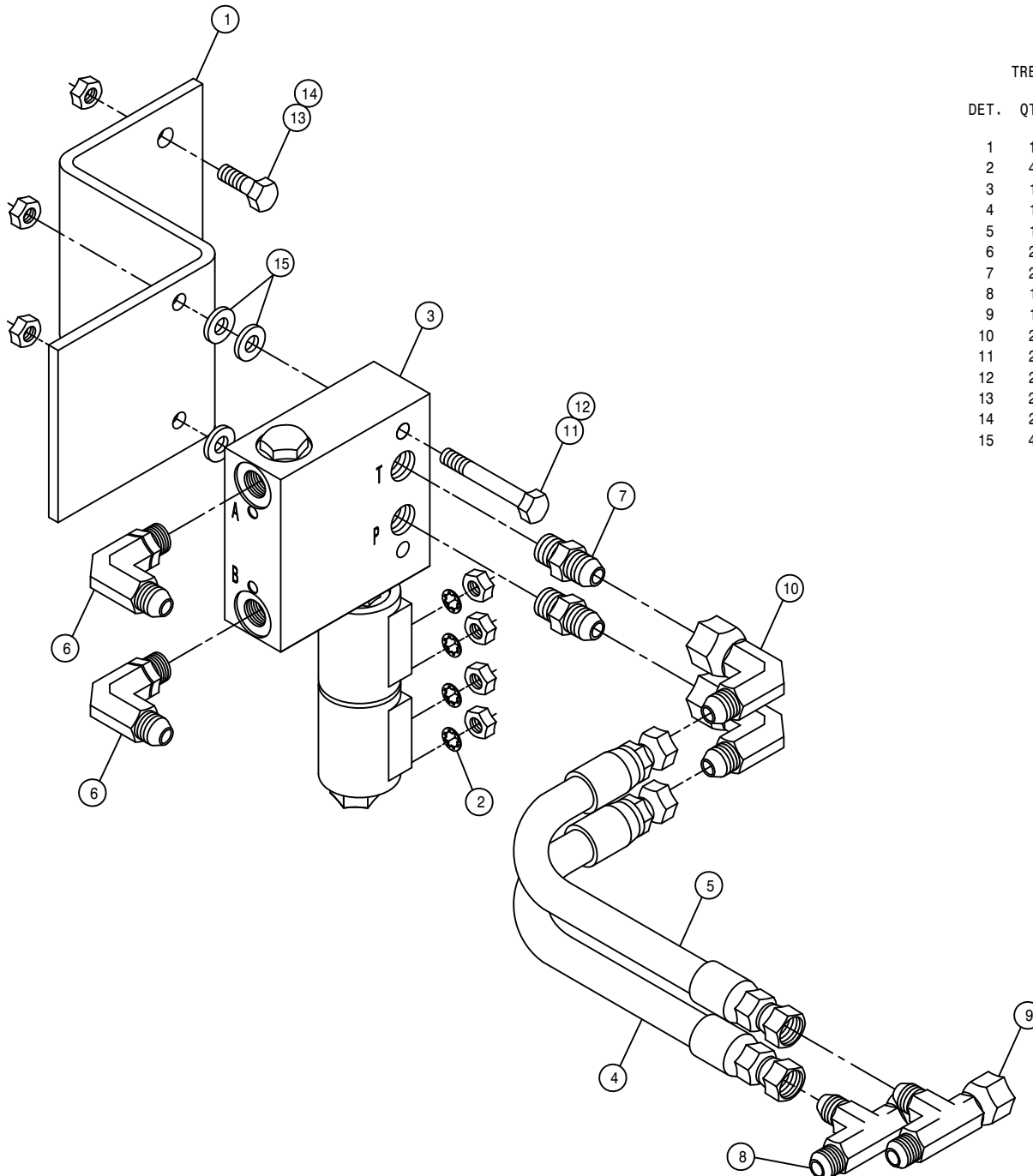

TREAD ADJUST CONTROL VALVE ASSEMBLY

DET. QTY PART NO. DESCRIPTION

DET.	QTY	PART NO.	DESCRIPTION
1	1	164652	TREAD ADJ VLV MT, 284
2	4	473802	# 8 INT TOOTH STAR WASHER
3	1	606100	TREAD ADJ VLV,284/XP,PWRSYS 03
4	1	615473	06C1T-06FJX-08FJX-18 H/A
5	1	615620	06C1T-06FJX-06FJX-18 H/A
6	2	618119	9/16MJIC-90-9/16MOR LBO
7	2	618126	9/16MJIC-9/16MOR ADPTR
8	1	618451	3/4FJIC SW RUN TEE-3/4MJIC
9	1	618486	9/16FJIC SW RUN TEE-9/16MJIC
10	2	618618	9/16MJIC-90-9/16FJIC SWIV LBO
11	2	900086	5/16UNC X 2 1/4 HEX BOLT
12	2	914002	5/16UNC HEX STOVER NUT
13	2	900129	3/8UNC X 1" HEX BOLT
14	2	914004	3/8UNC HEX STOVER NUT
15	4	920001	5/16 SAE FLAT WASHER

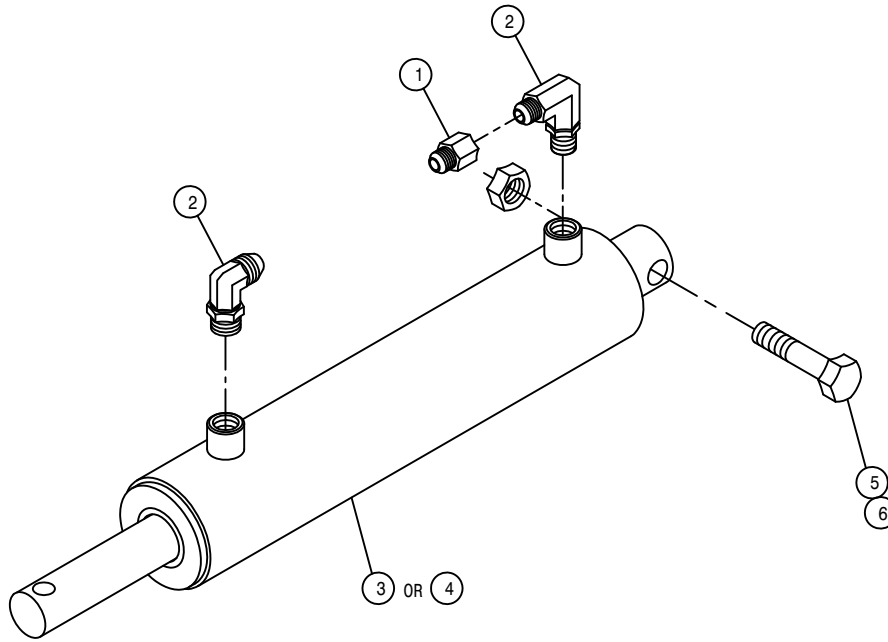

TREAD ADJUSTMENT LEG CYLINDER ASSEMBLY

DET. QTY PART NO. DESCRIPTION

1	1	618731	9/16JIC .025 ORIFICE ADPTR
2	2	618119	9/16MJIC-90-9/16MOR LBO
3	1	621534	LH TRD ADJ CYL,DTS8T-DTS10 04
4	1	621536	RH TRD ADJ CYL,DTS8T-DTS10 04
5	1	900268	1/2UNC X 2 1/2 HEX BOLT
6	1	914008	1/2UNC HEX STOVER NUT
NS	1	621535	REPAIR KIT, HYD CYL 621534
NS	1	621537	REPAIR KIT, HYD CYL 621536

NOTE: 1. 621220 - LH LEG TREAD ADJ CYLINDER ASSEMBLY WITH FITTINGS  
 2. 621221 - RH LEG TREAD ADJ CYLINDER ASSEMBLY WITH FITTINGS

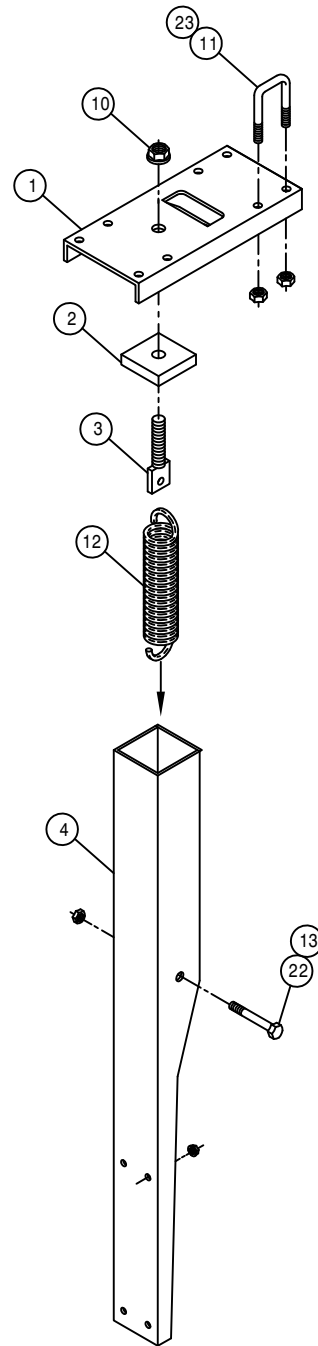
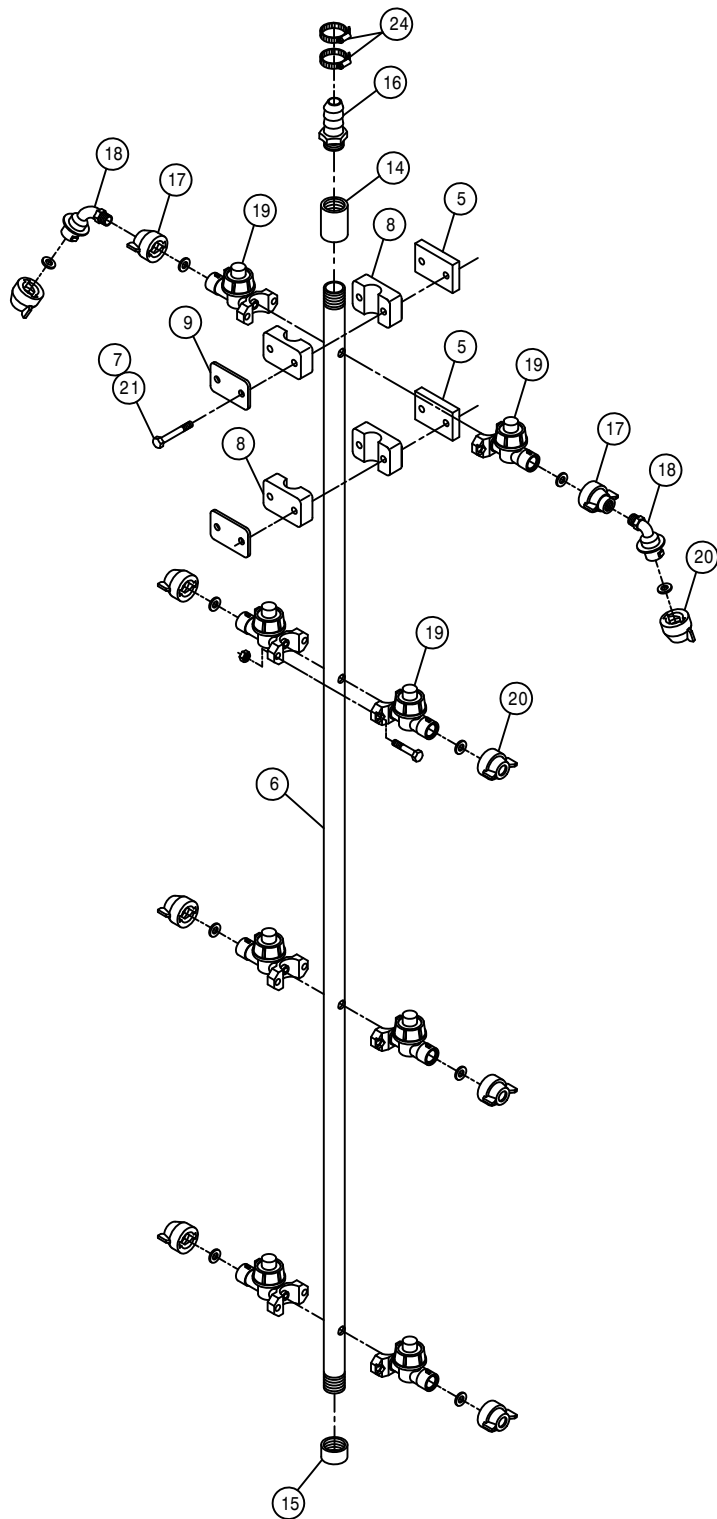

6' DROP NOZZLE ASSEMBLY

DET.	QTY	PART NO.	DESCRIPTION
	1	164761	6'DROP MT BASE CHAN, 284TXP 03
	1	164762	6'DROP PIVOT PAD WLD,284TXP 03
	1	164764	6'DROP SPRING BOLT WLD, TXP 03
	4	164766	6'DROP PIVOT CHAN WLD,284TXP03
	2	164769	DROP TUBE CLAMP SPACER, 284TXP
	1	164770	6'DROP WET TUBE 284TXP 03
	4	470121	1/4UNC HEX FLANGE LOCK NUT
	2	470358	TUBE CLAMP BODY, .840 (1/2PIPE)
	2	470359	COVER PLATE FOR 470358
	1	470360	1/2UNC HEX FLANGE LOCK NUT
	4	473973	.31UNC-1.31ID-2.0 SQ U-BOLT SS
	1	482022	SPRING,1.718 X 8.00 EXTENSION
	1	914004	3/8UNC HEX STOVER NUT
	1	507734	SS PIPE COUPLING .50NPT
	1	507735	1/2FNPT PIPE CAP, SS
	1	618281	1/2MNPT X 1/2 HOSE INSERT
	2	737835	QUICK TEEJET-1/4"FNPT ADPTR
	2	737842	1/4MNPT-45-QUICK TEEJET ADPTR
	8	737919	NOZL BODY, WET BOOM, 1/2" PIPE
	8	737920	CAP SET, BLACK, QUICK TEEJET
	4	900008	1/4UNC X 2 1/2 HEX BOLT
	1	900136	3/8UNC X 3" HEX BOLT
	8	914002	5/16UNC HEX STOVER NUT
	2	520055	HOSE CLAMP NO 12 STAINLESS

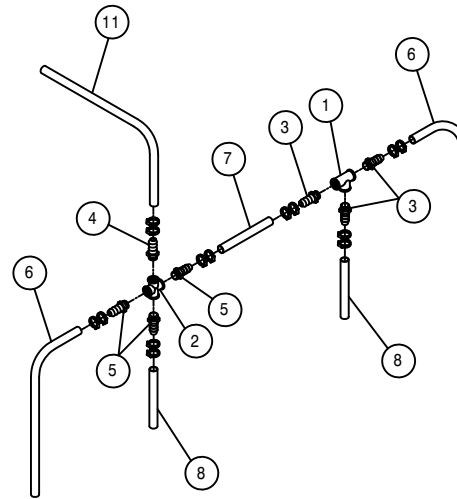
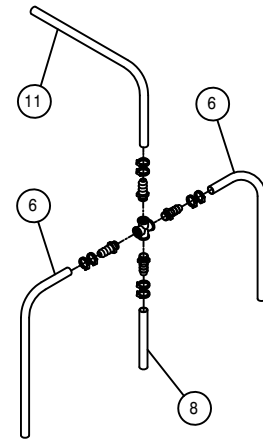
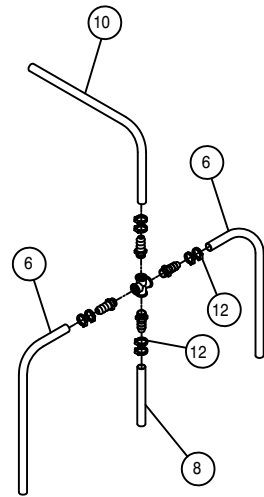
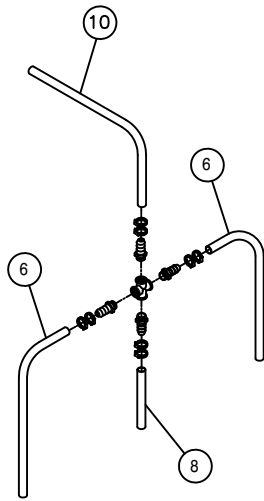
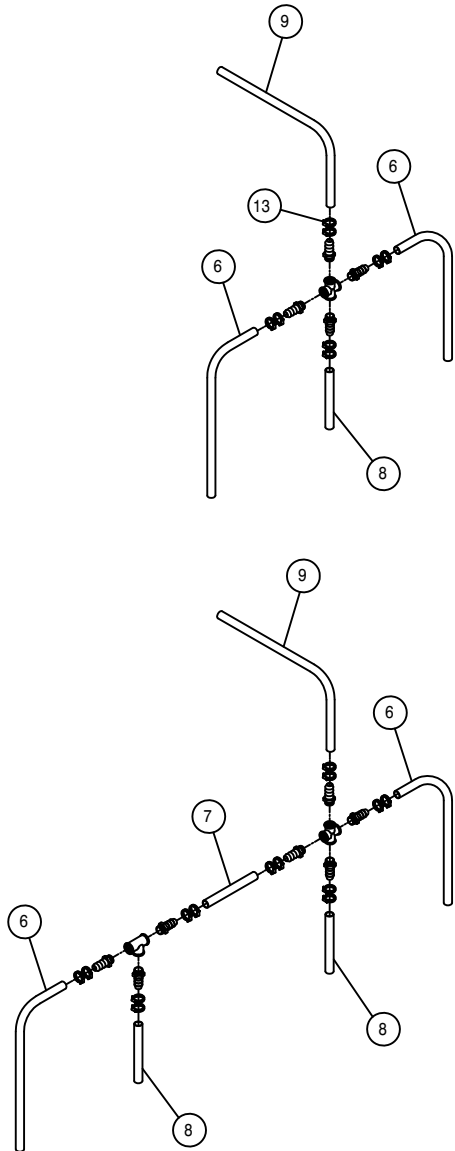

6-DROP HOSING

11-DROP HOSING

6 AND 11 DROP HOSING

DET. QTY PART NO. DESCRIPTION

1	2	507736	1/2FNPT PIPE TEE SS
2	6	507738	3/4FNPT PIPE CROSS SS
3	6	618281	1/2MNPT X 1/2 HOSE INSERT
4	6	713220	HOSE BARB 3/4 NPT X 3/4
5	18	714350	HOSE BARB 3/4 NPT X 1/2
6	12	601199	HOSE, 1/2 X 105 2BR BLK EPDM
7	2	601601	HOSE, 1/2 X 70 2BR BLK EPDM
8	8	601333	HOSE, 1/2 X 48 2BR BLK EPDM
9	2	601339	HOSE, 3/4 X 216 2BR BLK EPDM
10	2	601337	HOSE, 3/4 X 96 2BR BLK EPDM
11	2	601340	HOSE, 3/4 X 276 2BR BLK EPDM
12	48	520055	HOSE CLAMP NO 12 STAINLESS
13	12	520090	HOSE CLAMP NO 16 STAINLESS

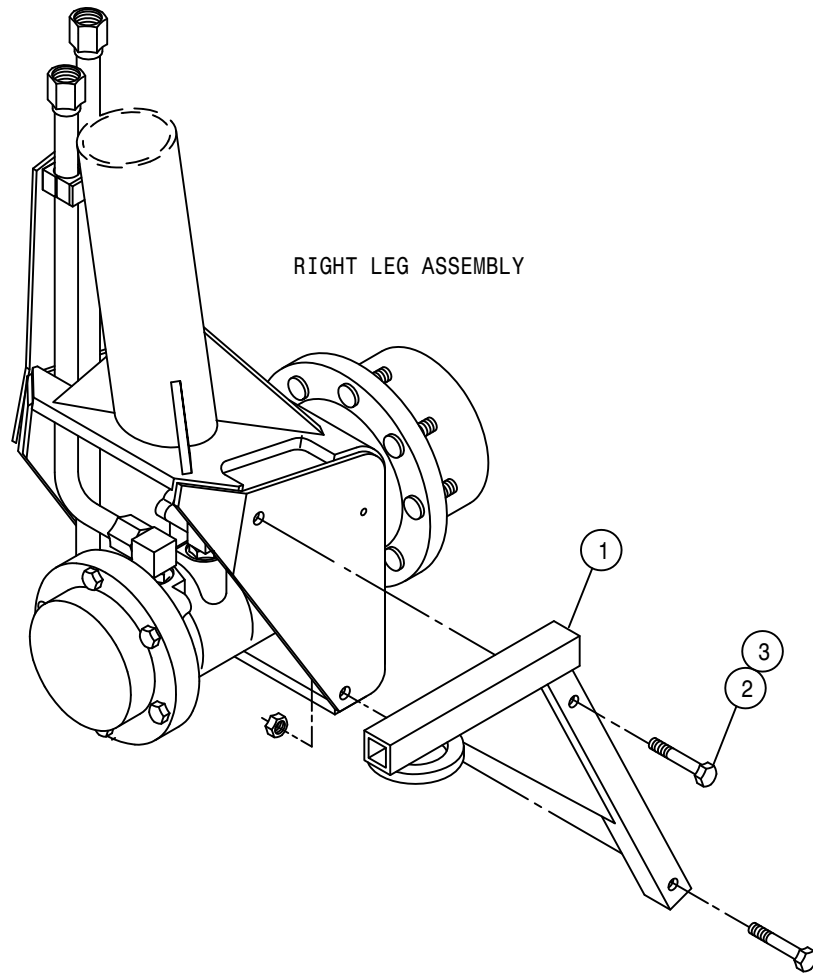

RIGHT LEG ASSEMBLY

JACK STAND ASSEMBLY

DET.	QTY	PART NO.	DESCRIPTION
1	1	359108	JACK MT WLD, 284TXP
2	2	900268	1/2UNC X 2 1/2 HEX BOLT
3	2	914008	1/2UNC HEX STOVER NUT

# NOTICE

---

The following page contains decals for the model DTS 8T

These decals can be obtained from Hagie Mfg. Co. and should be used whenever your machine is repainted or when the decals become worn, weathered, or faded.

Special attention should be paid to decals involving personal safety. They have been attached for your protection.

**KEEP THEM IN PLACE.**

Contact: Hagie Manufacturing Co.  
721 Central Ave West  
Box 273  
Clarion, Iowa 50525-0273



DTS 8T DECALS

QTY.	PART NO.	DESCRIPTION	LOCATION
1	650831	EMERGENCY STOP DECAL	ON LOWER LH FRONT CAB FOAM
1	650175	EMERGENCY EXIT DECAL	ON MONITOR MOUNTING BRACKET
1	650375	CONSOLE COVER PANEL DECAL	ON CONSOLE SHEET METAL
1	650340	PARK BRAKE DECAL	NEAR PARK SWITCH
1	650822	SOLUTION PUMP DECAL	ON FRONT CROSSMEMBER
1	650847	NO PASSENGER DECAL	REAR CORNER OF CAB
2	650848	SLIP OR FALL DECAL	2-ON EACH FUEL TANK
2	650849	ENGINE FUEL DECAL	NEAR EACH FUEL TANK NECK
2	650850	CHEMICAL DECAL	ON SOLUTION TANK LIDS
2	650851	SHIELDS DECAL	ON SIDE OF TOP ENGINE COVER
1	650852	READ MANUAL DECAL	ON LOWER LH FRONT CAB FOAM
1	650154	PATENTS,HAGIE UPFRONT DECAL	ON LOWER LEFT REAR OF MAINFRAME
2	650954	DIESEL DECAL	NEAR EACH FUEL NECK
1	650981	COOLING SYSTEM DECAL	NEAR RADIATOR CAP
1	650982	ELECTRICAL DECAL	RIGHT HAND SIDE OF OIL TANK
4	650985	WHEEL BOLT TORQUE DECAL	ON EACH WHEEL RIM
1	KDC201	DECAL SET, DTS 8T	ON EACH ENGINE HOOD
1	650329	SPRAY CONTROL/TRAC DECAL	ON INSTRUMENT PANEL
1	650336	FOLD BOOM WARNING DECAL	ON LOWER REAR OF EXIT WINDOW
1	650337	ELECTROCUITION HAZARD DECAL	ON LOWER REAR OF EXIT WINDOW
1	650339	HYDRAULIC OIL INJ. DECAL	ON LOWER REAR OF EXIT WINDOW
1	650347	NOTICE-R134A CHARGE DECAL	NEXT TO A/C COMPRESSOR
1	650348	NOTICE-DRAIN AIR TANK DECAL	ON AIR TANK
1	650367	AIR FILTER INSTRUCTION DECAL	ON ENGINE AIR FILTER END CAP
1	650176	CAUTION,CAB CHEM EXPOSUR	ON CAB ASSY
1	650212	DECAL SET,DTS 8 RH TANK MOLDIN	ON RIGHT SIDE OF SOLUTION TANK
1	650213	DECAL SET,DTS 8 LH TANK MOLDIN	ON LEFT SIDE OF SOLUTION TANK

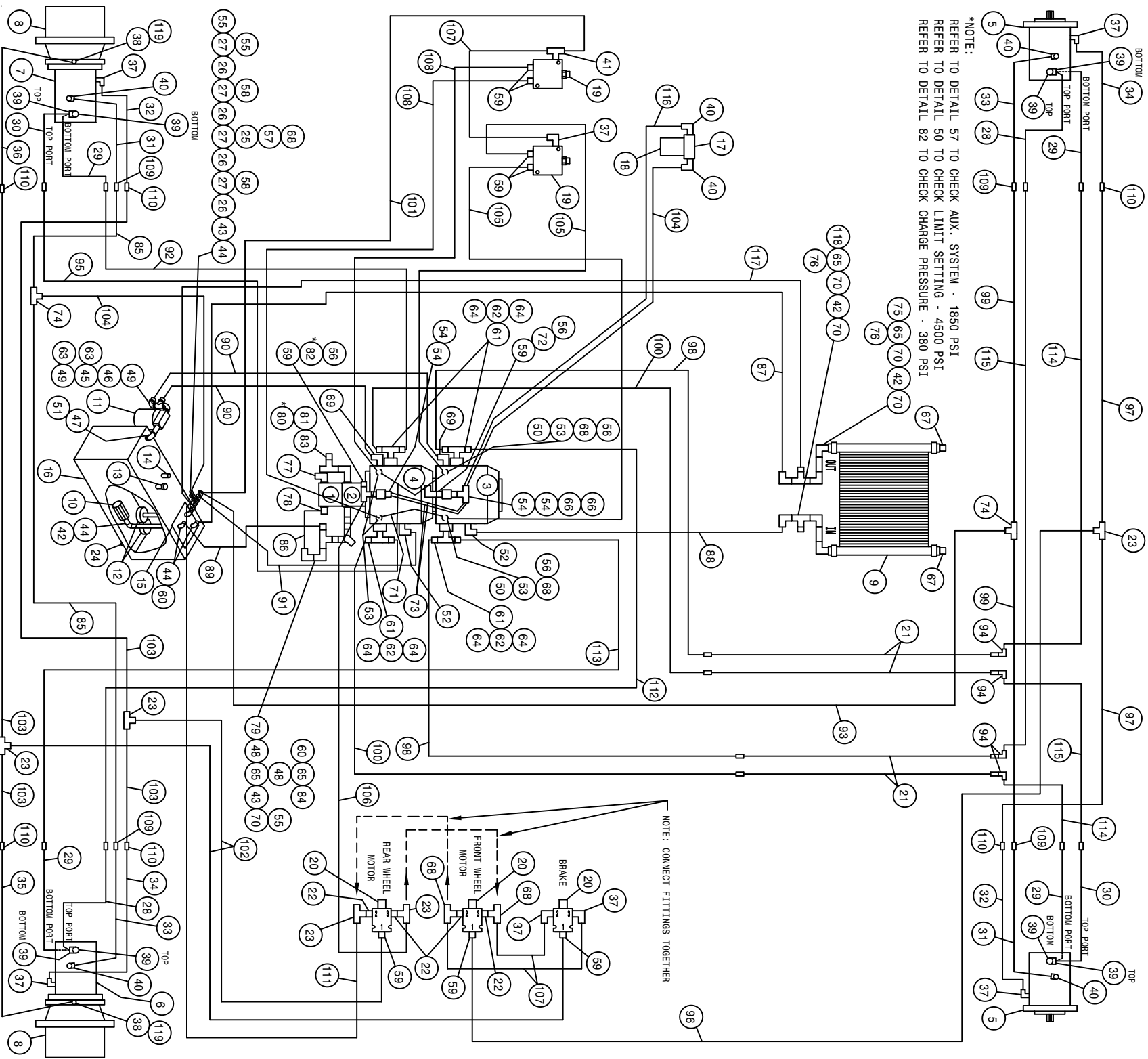

\*NOTE:  
 REFER TO DETAIL 57 TO CHECK AUX. SYSTEM - 1850 PSI  
 REFER TO DETAIL 50 TO CHECK LIMIT SETTING - 4500 PSI  
 REFER TO DETAIL 82 TO CHECK CHARGE PRESSURE - 380 PSI

NOTE: CONNECT FITTINGS TOGETHER

DTS 8T HYDRAULIC SCHEMATIC 2008  
REFERENCE DRAWING NO. 49897/4S1

DET.	QTY	PART NO.	DESCRIPTION	DET.	QTY	PART NO.	DESCRIPTION
1	1	606929	SUND GEAR PUMP .66CI, SPLINED	60	3	714560	1NPT X 1 HOSE BARB
2	1	606932	SUND GEAR PUMP,1.60CI,SPLINED	61	4	618598	1" 4-BOLT FLG X 1 5/16 FOR
3	1	606231	SUND 75CC PUMP,C/C MT (.022)	62	4	618599	1 5/16MOR BRANCH TEE-1 5/16MJ
4	1	606234	SUND 75CC PUMP, C/B MT (.022)	63	2	715664	1 1/4 NPT X 1 HOSE BARB
5	2	610637	SUND HYD MOTOR, M46-4019	64	8	618640	1 5/16MJ-90-1 5/16FJ SWIV LBO
6	1	608000	SAUER HYD MOTOR, M46-4024	65	4	505101	BLK PIPE TEE 1.00NPT
7	1	608003	SUND HYD MOTOR, M46-4194 W/SEN	66	2	618643	3/4FJ SW BRANCH TEE-3/4MJ
8	2	610847	TORQ HUB, 7HBA 29:1 W/BRAKE	67	2	505102	PIPE PLUG 1.00NPT SQ HD
9	1	618606	OIL COOLER, BLISSFIELD 65027	68	5	618486	9/16FJIC SW RUN TEE-9/16MJIC
10	1	605600	TANK FILTER, 100 MESH,1"FNPT	69	5	618564	1IN HOSE BARB-90-1 5/16MOR
11	1	605601	PARKER FILTER ASSY, 10M, 1.25NPT	70	5	505200	BLK PIPE ST EL 90DEG 1.00NPT
12	2	605603	LINE SUMP DIFFUSER	71	2	616252	04C2AT-06FJX-06FJX-13
13	1	611052	FILLER BREATHER 3/4NPT	72	1	618618	9/16MJIC-90-9/16FJIC SWIV LBO
14	1	614453	DIPSTICK, 8IN	73	2	614739	08C1T-08FJX-08FJX90-16
15	1	760090	RECEIVER PLT WLD 8240	74	2	618311	3/4MJIC UNION TEE
16	1	760264	HYD TANK WLD,204/254/284 2002	75	1	618138	1IN HOSE BARB-90-1MNPT
17	1	605608	HYD FILTER HEAD, DONALDSON	76	2	714331	3/4MJIC-90-7/8MOR LBO
18	1	605609	HYD FILTER ELEMENT, DONALDSON	77	1	618183	3/4MJIC-90-1 1/16FJ HOSE BARB
19	2	610580	REMOTE FLUSHING VALVE, SUND	78	1	618075	3/4 HOSE BARB-1 1/16MOR
20	3	606138	HYD SOLE VLV,2P-3W,9/16FOR, WP	79	1	618090	1 5/16MOR-1FNPT ADPTR
21	4	615724	FRT MAIN HYD TUBE ASSY, 2100 98	80	1	618328	7/8FJIC CAP NUT
22	4	618668	9/16FJIC SWIV-9/16MOR ADPTR	81	1	618333	7/8FJIC SW RUN TEE-7/8MJIC
23	5	618019	9/16MJIC UNION TEE	82	1	618514	9/16FJ SW BRANCH TEE-9/16MJ
24	1	470308	1/2MNPT DRAIN PLUG, AL HD, MAG	83	1	618335	7/8MJIC-90-1 1/16MOR LBO
25	1	504001	RED BUSH 3/4 X 1/4 BLK MAL	84	1	716000	3/4 HOSE BARB-90-1MNPT
26	4	504702	CLOSE NIPPLE .75NPT	85	2	614689	08C1T-08FJX-08FJX-120
27	4	504955	BLK PIPE TEE .75NPT	86	1	601399	HOSE, 3/4 X 13 IFBR-1SPI
28	2	615708	UPR HYD TUBE ASSY, LEG 2100 03	87	1	601404	HOSE, 1 X 87 IFBR-1SPI
29	4	615708	LMR HYD TUBE ASSY, LEG 2100 98	88	1	601385	HOSE, 3/4 X 65 IFBR-1SPI
30	2	615709	UPR HYD TUBE ASSY, LEG 2100 98	89	1	601594	HOSE, 1 X 56 IFBR-1SPI
31	2	615710	RF/LR HYD DRN TUBE ASSY2100 98	90	2	601596	HOSE, 1 X 30 IFBR-1SPI
32	2	615712	RF/LR HYD CTRL TUBE ASSY210098	91	1	601595	HOSE, 3/4 X 28 IFBR-1SPI
33	2	615809	LF/RR HYD DRN TUBE ASSY2100 03	92	1	616196	12TWM-16FJX-16MJ-126
34	2	615713	LF/RR HYD CTRL TUBE ASSY210098	93	1	616194	08C2AT-08FJX-08FJX90-144
35	1	615815	RH HYD BRAKE TUBE ASSY, 2101 04	94	4	618191	1 1/16MJ-90-1 1/16FJ SWIV LBO
36	1	615715	LH HYD BRAKE TUBE ASSY, 2100 98	95	1	616198	12TWM-16FJX-16MJ-138
37	7	618119	9/16MJIC-90-9/16MOR LBO	96	1	616191	04C1T-06FJX-06FJX-138
38	2	618304	9/16MJIC-7/16MOR ADPTR	97	2	615730	04C1T-06FJX-06FJX-150
39	8	618178	1 5/16MJIC-90-1 5/16MOR LBO	98	2	616199	12TWM-16FJX-12MJ-42
40	6	618474	3/4MJIC-90-1 1/16MOR LBO	99	2	616193	08C1T-08FJX-08FJX-148
41	1	618444	9/16MOR RUN TEE-9/16MJIC	100	2	616200	12TWM-16FJX-12MJ-55
42	3	505203	BLK PIPE NIPPLE 1.00NPT-4.00	101	1	616048	04C1T-06FJX-06FJX-35
43	2	505213	RED BUSH 1 X 3/4 BLK MAL	102	2	616036	04C1T-06FJX-06FJX-12
44	4	505300	BLK PIPE EL 90DEG 1.00NPT	103	4	614076	04C1T-06FJX-06FJX-119
45	1	506105	BLK PIPE TEE 1.25NPT	104	2	616034	08C1T-08FJX-08FJX-17
46	1	506303	CLOSE NIPPLE 1.25NPT	105	2	616255	04C2AT-06FJX-06FJX-29
47	1	505105	BLK PIPE EL 90DEG 1.25NPT	106	1	614715	04C1T-06FJX-06FJX-43
48	2	505105	1MNPT HEX PIPE NIPPLE STL	107	3	616042	04C1T-06FJX-06FJX-13
49	2	506410	BLK PIPE ST EL 90DEG 1.25NPT	108	2	616254	04C2AT-06FJX-06FJX-26
50	2	618734	9/16JIC .047 ORIFICE ADPTR	109	4	618314	3/4MJIC UNION
51	1	506602	PIPE NIPPLE 1 1/4NPT-2 1/2	110	6	619010	9/16MJIC UNION
52	2	618118	3/4 HOSE BARB-90-1 1/16MOR	111	1	614663	04C1T-06FJX-06FJX-16
53	4	618629	9/16MOR BRANCH TEE-9/16MJIC	112	1	616197	12TWM-16FJX-16MJ-132
54	4	610327	3/4MJIC-7/8MOR ADPTR	113	1	616195	12TWM-16FJX-16MJ-110
55	3	610300	3/4MJIC-3/4MNPT ADPTR	114	2	616202	12TWM-12MJ-16MJ-134
56	4	618531	9/16FJIC CAP NUT	115	2	616201	12TWM-12MJ-16MJ-166
57	1	618520	1/4MNPT RUN TEE-9/16MJIC	116	1	616192	08C1T-08FJX-08FJX-21
58	2	713220	HOSE BARB 3/4 NPT X 3/4	117	1	601401	HOSE, 3/4 X 88 IFBR-1SPI
59	9	618126	9/16MJIC-9/16MOR ADPTR	118	1	716000	3/4 HOSE BARB-90-1MNPT
				119	2	618634	9/16MJIC-45-9/16FJIC SWIV LBO

BOOM CONTROL VALVE

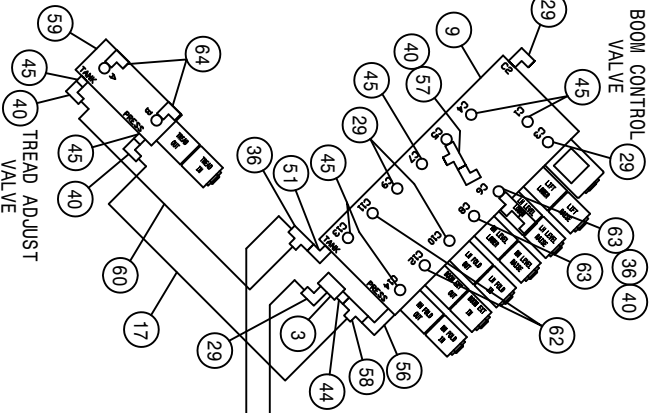

TREAD ADJUST VALVE

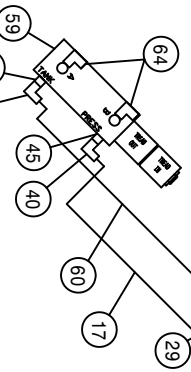

NOTE: REFER TO DETAIL 7 RELIEF PRESSURE SETTING.  
 \*\*BOOM RELIEF SETTING - 2850 PSI

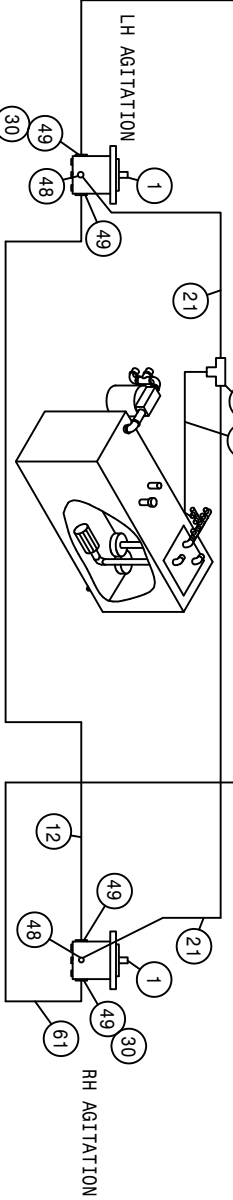
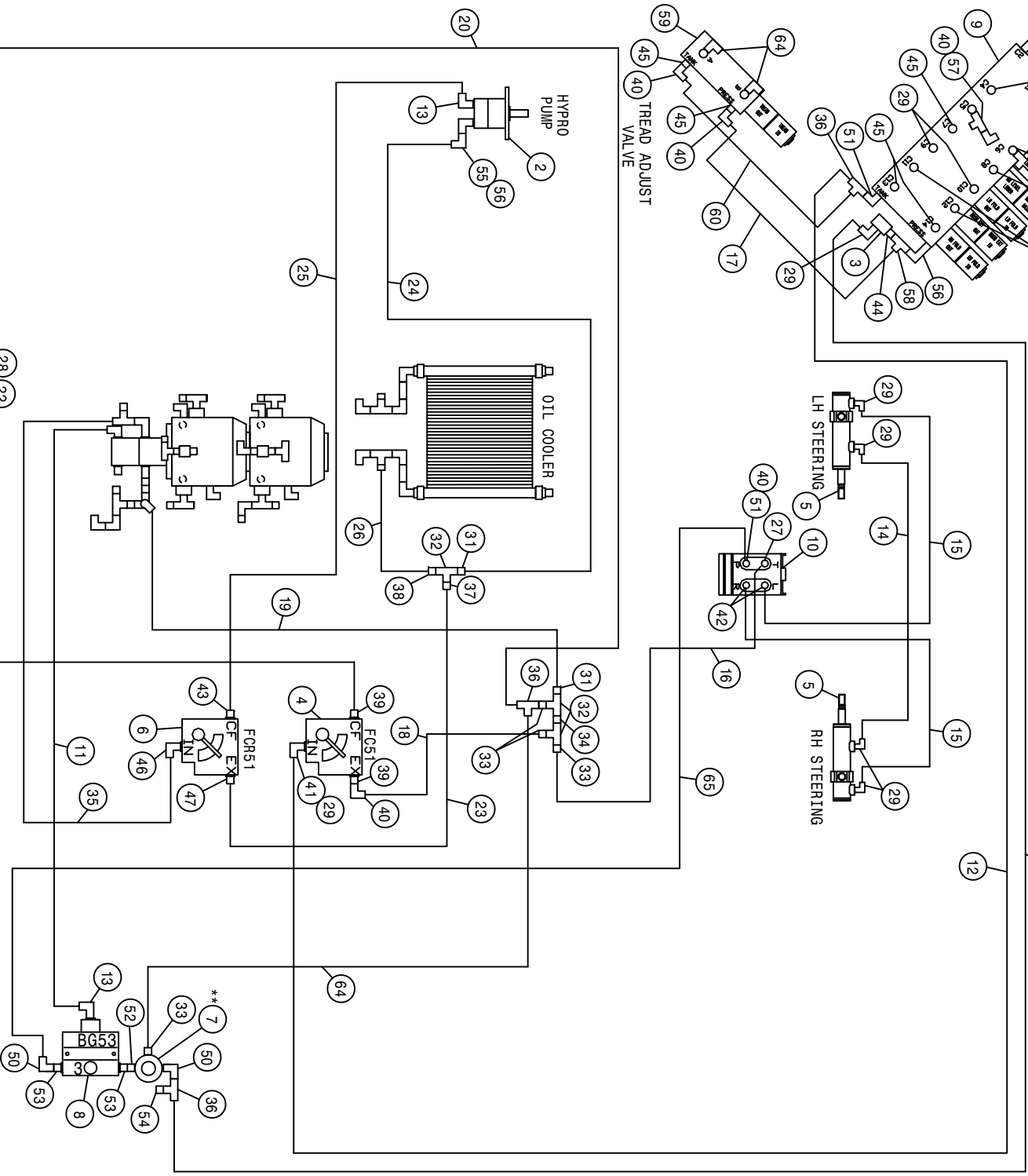
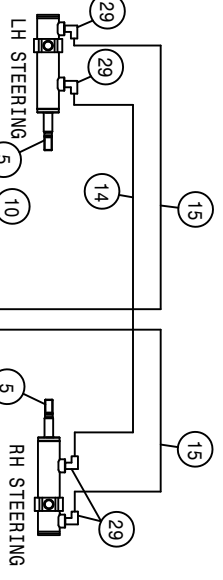

DTS 8T HYDRAULIC SCHEMATIC 2008  
REFERENCE DRAWING NO. 498974S2

DET.	QTY	PART NO.	DESCRIPTION	DET.	QTY	PART NO.	DESCRIPTION
1	2	606324	GEAR MTR,1.41CI EATON	33	4	618018	9/16MJIC-1/2MNPT ADPTR
2	1	695985	CHAR LYNN 2000 HYD MTR, 6.1CI	34	1	503600	CLOSE NIPPLE .50NPT
3	1	605615	HYD FILTER, INLINE 25M 9/16FOR	35	1	616204	10C1T-10FJX-10FJX-113 H/A
4	1	606827	FLO CONT FC51 0-3 VARI 7/8FOR	36	4	618486	9/16FJIC SW RUN TEE-9/16MJIC
5	2	621512	STEERING CYL ASSY, 2.00 X 6.28	37	1	618325	7/8MJIC-1/2MNPT ADPTR
6	1	606818	FLO CONT FCR51 0-16GPM 7/8FOR	38	1	712440	1/2 NPT X 3/4 HOSE BARB
7	1	607512	RELIEF VALVE, RL50, 1850 PSI	39	2	618310	9/16MJIC-7/8MOR ADPTR
8	1	610307	FLO DIV BG53 3GPM PRI 7/8FOR	40	6	618618	9/16MJIC-90-9/16FJIC SWIV LBO
9	1	606102	BOOM VLV, X11/284/2100 PWRSYS03	41	1	618172	7/8MOR-9/16FOR ADPTR
10	1	749318	STRG MTR, 7.3CID, NON-LOAD 1031	42	2	618109	9/16MJIC-3/4MOR ADPTR
11	1	616498	10C1T-10FJX-10FJX-110 H/A	43	1	618327	3/4MJIC-7/8MOR ADPTR
12	2	614693	06C1T-06FJX-06FJX-168 H/A	44	1	618692	3/4FJIC SWIV-9/16MOR ADPTR
13	2	618183	3/4MJIC-90-7/8MOR LBO	45	7	618126	9/16MJIC-9/16MOR ADPTR
14	1	616206	04C1T-06FJX-06FJX-216 H/A	46	1	611128	7/8MJIC-90-7/8MOR LBO
15	2	616205	04C1T-06FJX-06FJX-117 H/A	47	1	611126	7/8MJIC-7/8MOR ADPTR
16	1	616172	04C1T-06FJX-06FJX-60 H/A	48	2	618425	9/16MJIC-45-9/16MOR LBO
17	1	615473	06C1T-06FJX-08FJX-18 H/A	49	4	618813	9/16MJIC-90-1 1/16MOR LBO
18	3	616026	04C1T-06FJX-06FJX-37 H/A	50	2	618107	9/16MJIC-90-1/2MNPT LBO
19	1	616057	08C1T-08FJX-08FJX-88 H/A	51	2	618115	9/16MJIC-90-3/4MOR LBO
20	1	614571	06C1T-06FJX-06FJX-126 H/A	52	1	500000	1/2MNPT HEX PIPE NIPPLE STL
21	2	611204	04C1T-06FJX-06FJX-78 H/A	53	2	618072	7/8MOR-1/2FNPT ADPTR
22	1	615452	06C1T-06FJX-06FJX-16 H/A	54	1	618531	9/16FJIC CAP NUT
23	1	615521	10C1T-10FJX-10FJX-18 H/A	55	1	618171	7/8MOR-3/4FOR ADPTR
24	1	614382	08C1T-08FJX-08FJX-40 H/A	56	2	618241	3/4MJIC-90-3/4MOR LBO
25	1	614662	08C1T-08FJX-08FJX-72 H/A	57	1	618444	9/16MOR RUN TEE-9/16MJIC
26	1	601384	HOSE, 3/4 X 40 1FBR-1SPI	58	1	618451	3/4FJIC SW RUN TEE-3/4MJIC
27	1	618709	9/16MJIC-90-3/4MOR EX LG LBO	59	1	606100	TREAD ADJ VLV, 284/XP, PWRSYS 03
28	1	618019	9/16MJIC UNION TEE	60	1	615620	06C1T-06FJX-06FJX-18 H/A
29	10	618119	9/16MJIC-90-9/16MOR LBO	61	1	614704	06C1T-06FJX-06FJX-156 H/A
30	2	618634	9/16MJIC-45-9/16FJIC SWIV LBO	62	2	610185	9/16MOR PLUG
31	2	611147	3/4MJIC-1/2MNPT ADPTR	63	2	614763	9/16MJIC-9/16MOR, .042 CHK ADPT
32	3	503820	BLK PIPE TEE .50NPT	64	1	616495	04C1T-06FJX-06FJX45-100 H/A
				65	1	616496	04C1T-06FJX-06FJX45-125 H/A
				66	1	616499	06C1T-06FJX-06FJX45-252 H/A

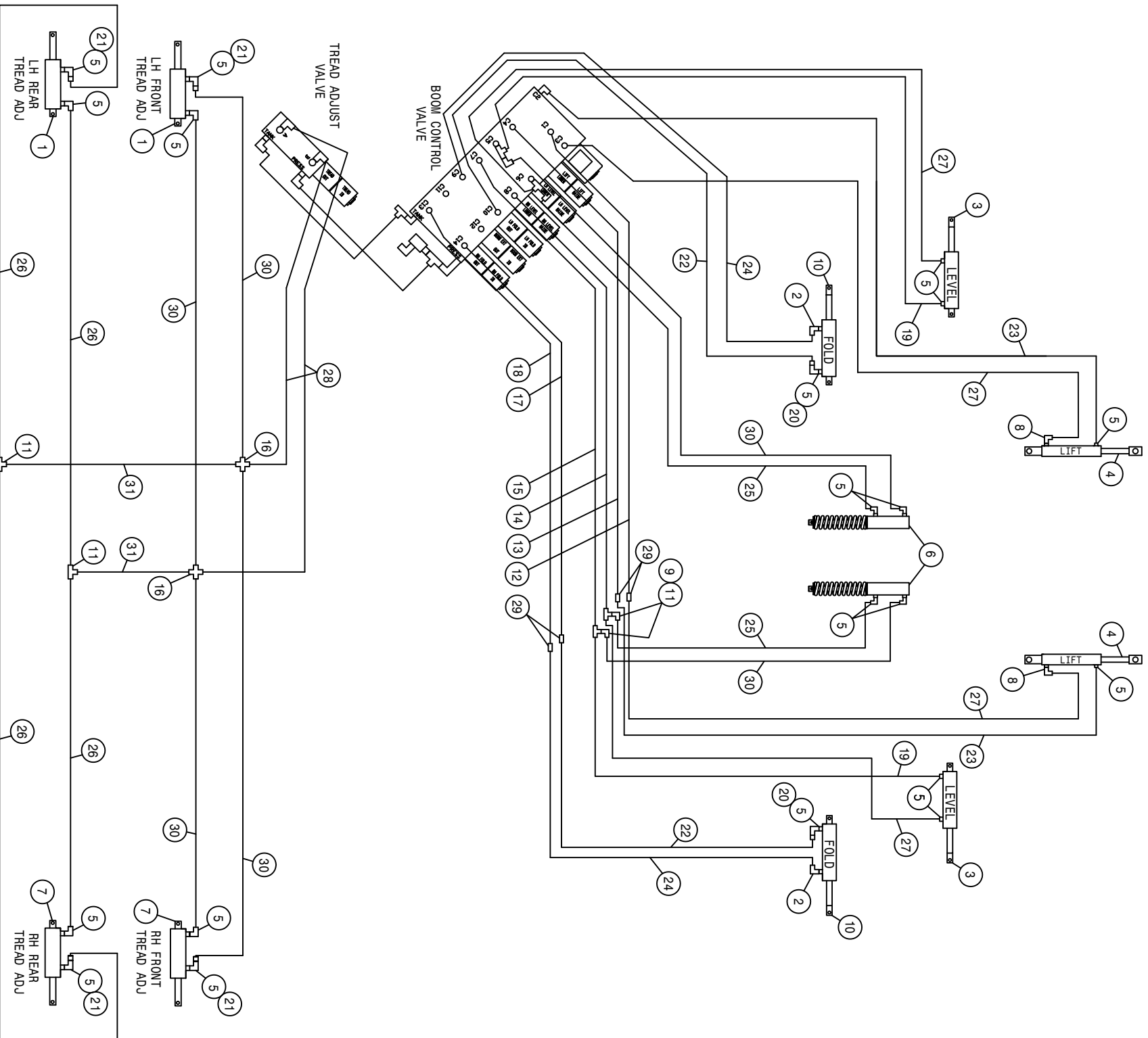

DTS 8T HYDRAULIC SCHEMATIC 2008  
REFERENCE DRAWING NO. 498974S3

DET.	QTY	PART NO.	DESCRIPTION	DET.	QTY	PART NO.	DESCRIPTION
1	2	621534	LH TRD ADJ CYL.DTS8T-DTS10	17	1	615790	RH FOLD RAISE HYD TUBE ASSYX11
2	2	618688	9/16MOR-90-9/16MJ .025 CHK VLV	18	1	615791	RH FOLD LOWER HYD TUBE ASSYX11
3	2	621522	BOOM LEVEL CYL ASSY	19	2	616172	04C1T-06FJX-06FJX-60
4	2	621518	TRANSOM LIFT CYL ASSY	20	2	618733	9/16JIC .042 ORIFICE ADPTR
5	20	618119	9/16MJIC-90-9/16MOR LBO	21	4	618731	9/16JIC .025 ORIFICE ADPTR
6	2	621524	ACCUMULATOR CYL ASSY	22	2	616207	04C1T-06FJX-06FJX-62
7	2	621536	RH TRD ADJ CYL.DTS8T-DTS10	23	2	616040	04C1T-06FJX-06FJX-67
8	2	618689	9/16MOR-90-9/16MJ .042 CHK VLV	24	2	615726	04C1T-06FJX-06FJX-73
9	2	618618	9/16MJIC-90-9/16FJIC SWIV LBO	25	2	616056	04C1T-06FJX-06FJX-32
10	2	621520	BOOM HINGE FOLD CYL ASSY	26	4	614715	04C1T-06FJX-06FJX-43
11	4	618019	9/16MJIC UNION TEE	27	4	616174	04C1T-06FJX-06FJX-70
12	1	615786	LIFT RAISE HYD TUBE ASSY X-11	28	2	611210	04C1T-06FJX-06FJX-156
13	1	615787	LIFT LOWER HYD TUBE ASSY X-11	29	4	619010	9/16MJIC UNION
14	1	615788	LEVEL RAISE HYD TUBE ASSY X-11	30	6	616026	04C1T-06FJX-06FJX-37
15	1	615789	LEVEL LOWER HYD TUBE ASSY X-11	31	2	611206	04C1T-06FJX-06FJX-66
16	2	618320	9/16MJIC UNION CROSS				H/A

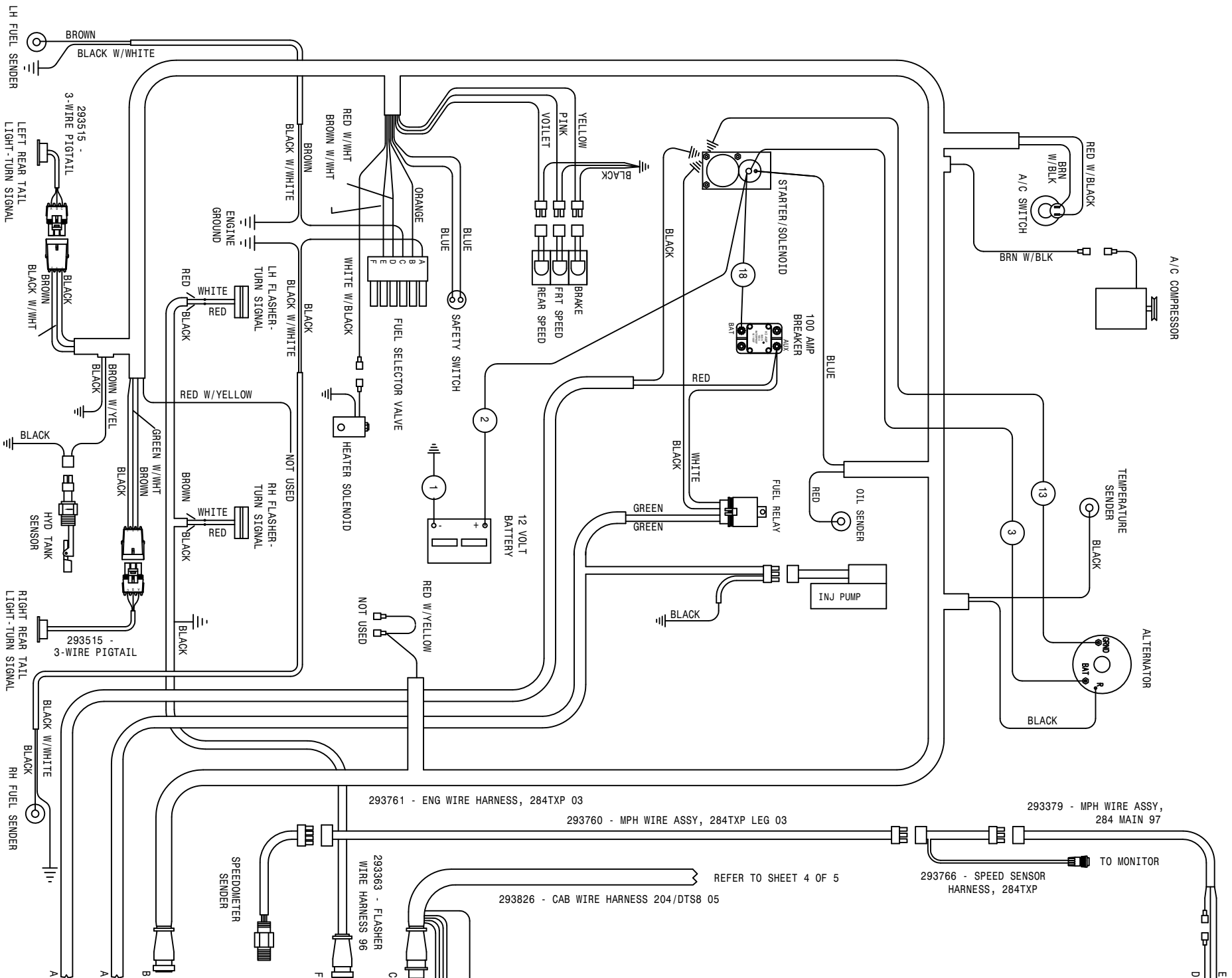





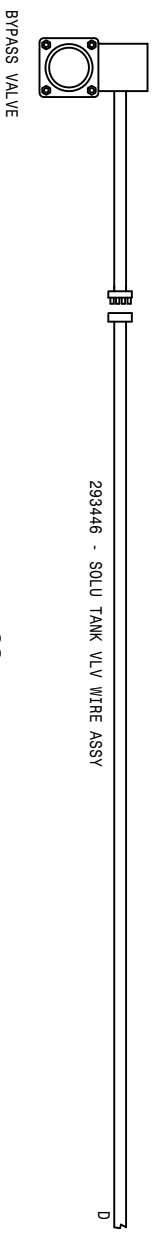
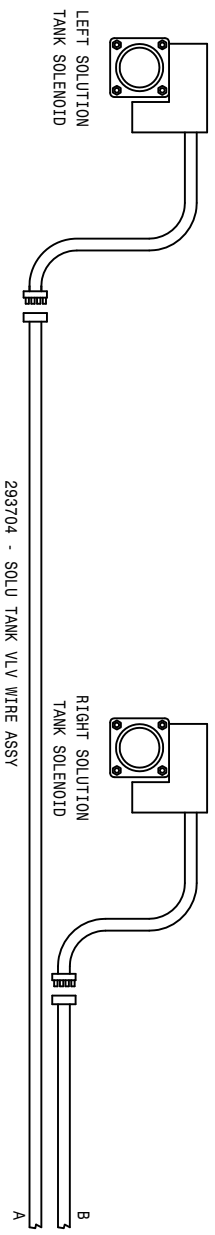
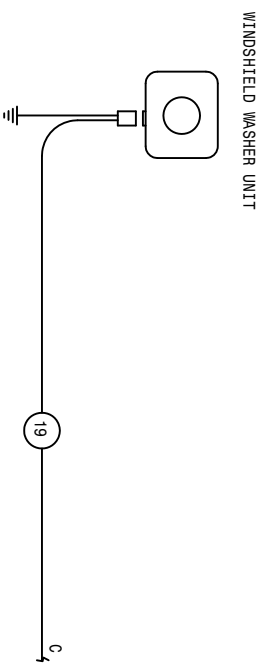

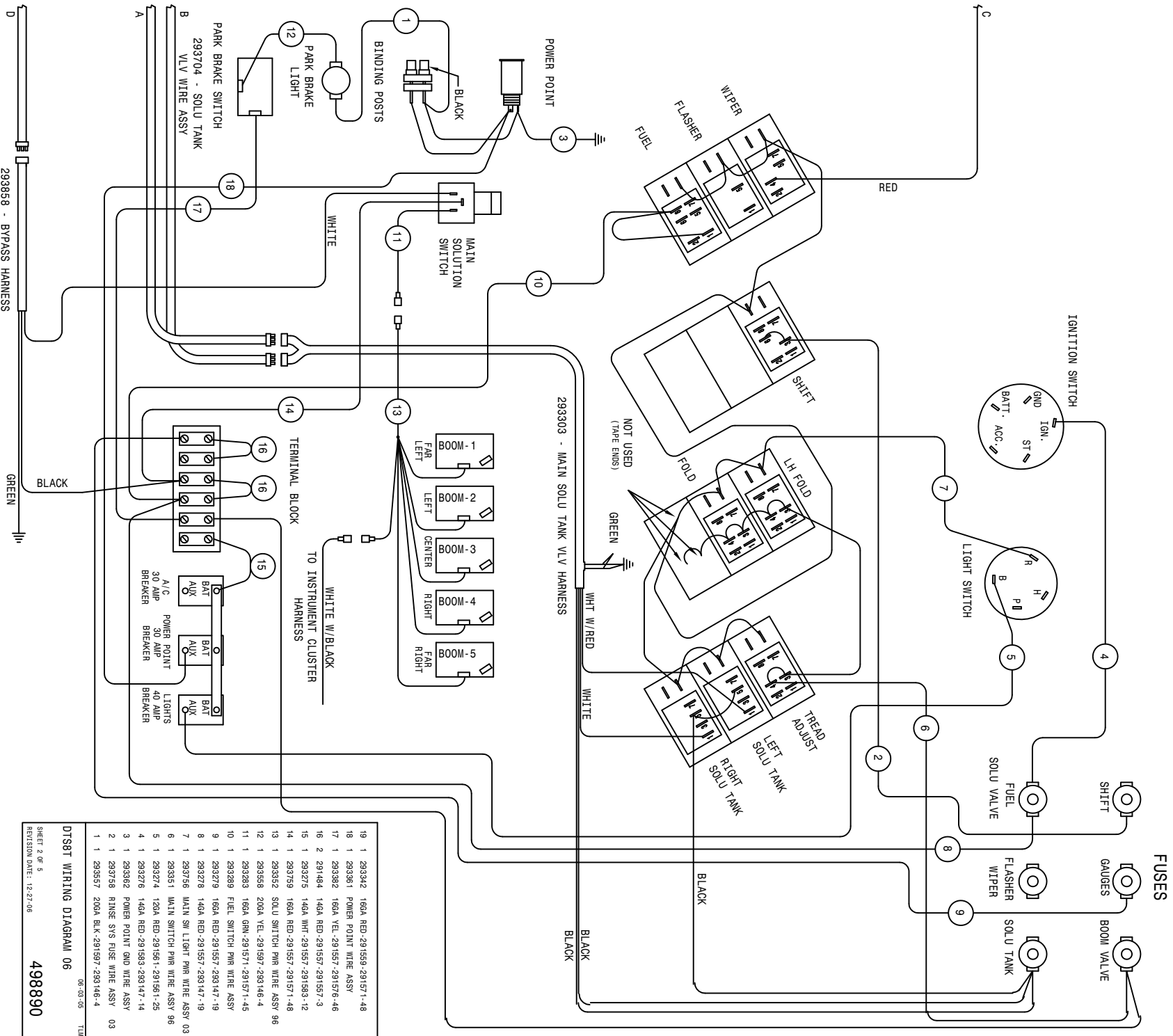

19	1	2933342	16GA RED-291559-291571-148
18	1	2933361	POWER POINT WIRE ASSY
17	1	2933362	16GA YEL-291557-291576-46
16	2	291484	14GA RED-291557-291557-3
15	1	293275	14GA WHT-291557-291583-12
14	1	293759	16GA RED-291557-291571-148
13	1	2933352	SOLU SWITCH PWR WIRE ASSY 96
12	1	293558	20GA YEL-291597-293146-4
11	1	293293	16GA GRN-291571-291571-145
10	1	293289	FUEL SWITCH PWR WIRE ASSY
9	1	293279	16GA RED-291557-293147-19
8	1	293278	14GA RED-291557-293147-19
7	1	293756	MAIN SW LIGHT PWR WIRE ASSY
6	1	293351	MAIN SWITCH PWR WIRE ASSY 96
5	1	293274	12GA RED-291561-291561-25
4	1	293276	14GA RED-291583-293147-14
3	1	293362	POWER POINT GND WIRE ASSY
2	1	293758	RANSE SIS FUSE WIRE ASSY 03
1	1	293557	20GA BLK-291597-293146-4

DTS8T WIRING DIAGRAM 06  
 SHEET 2 OF 5  
 REVISION DATE: 12-27-06  
 498890  
 06-03-05  
 TLU

HYDROSTATIC CONTROL HANDLE

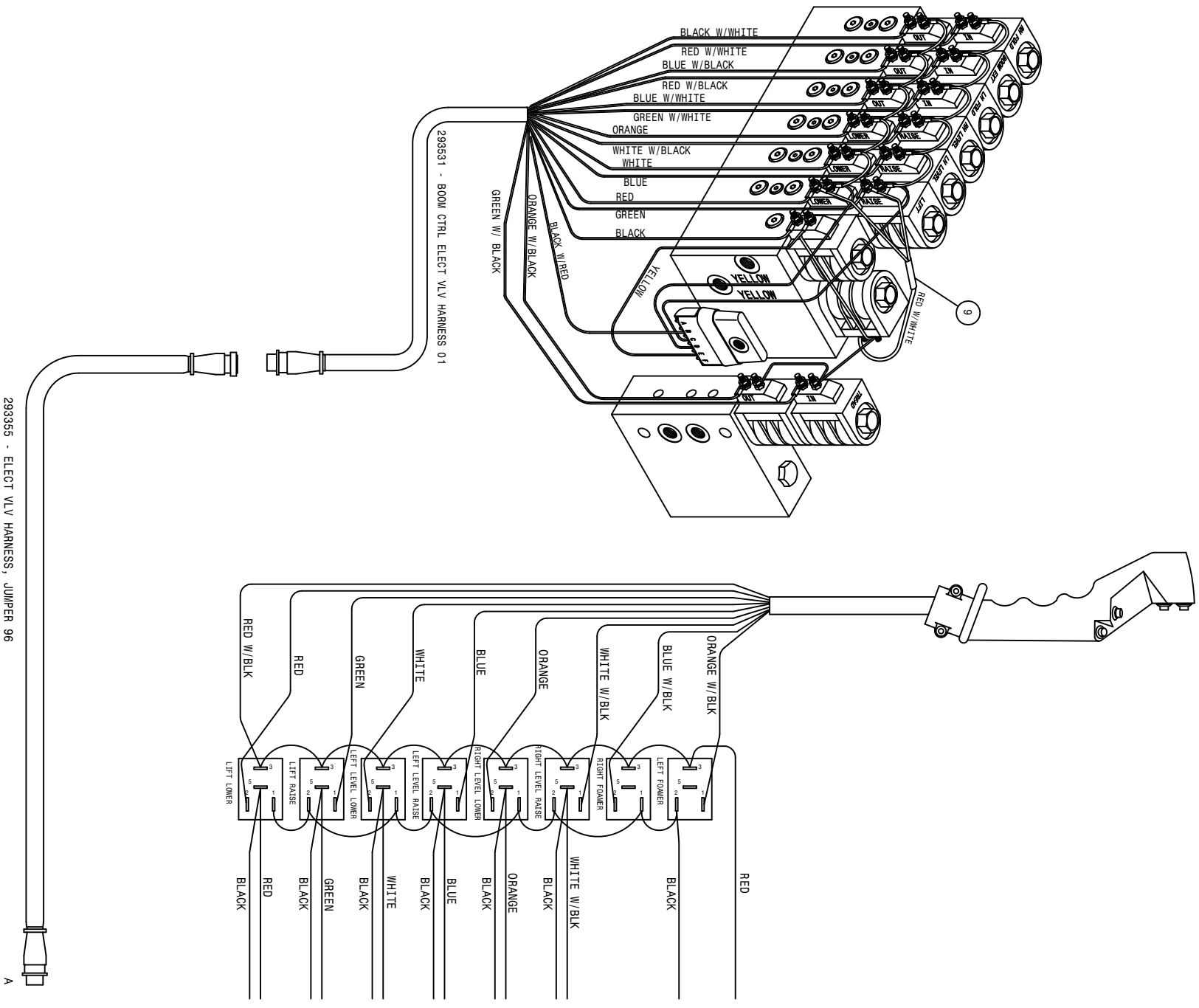

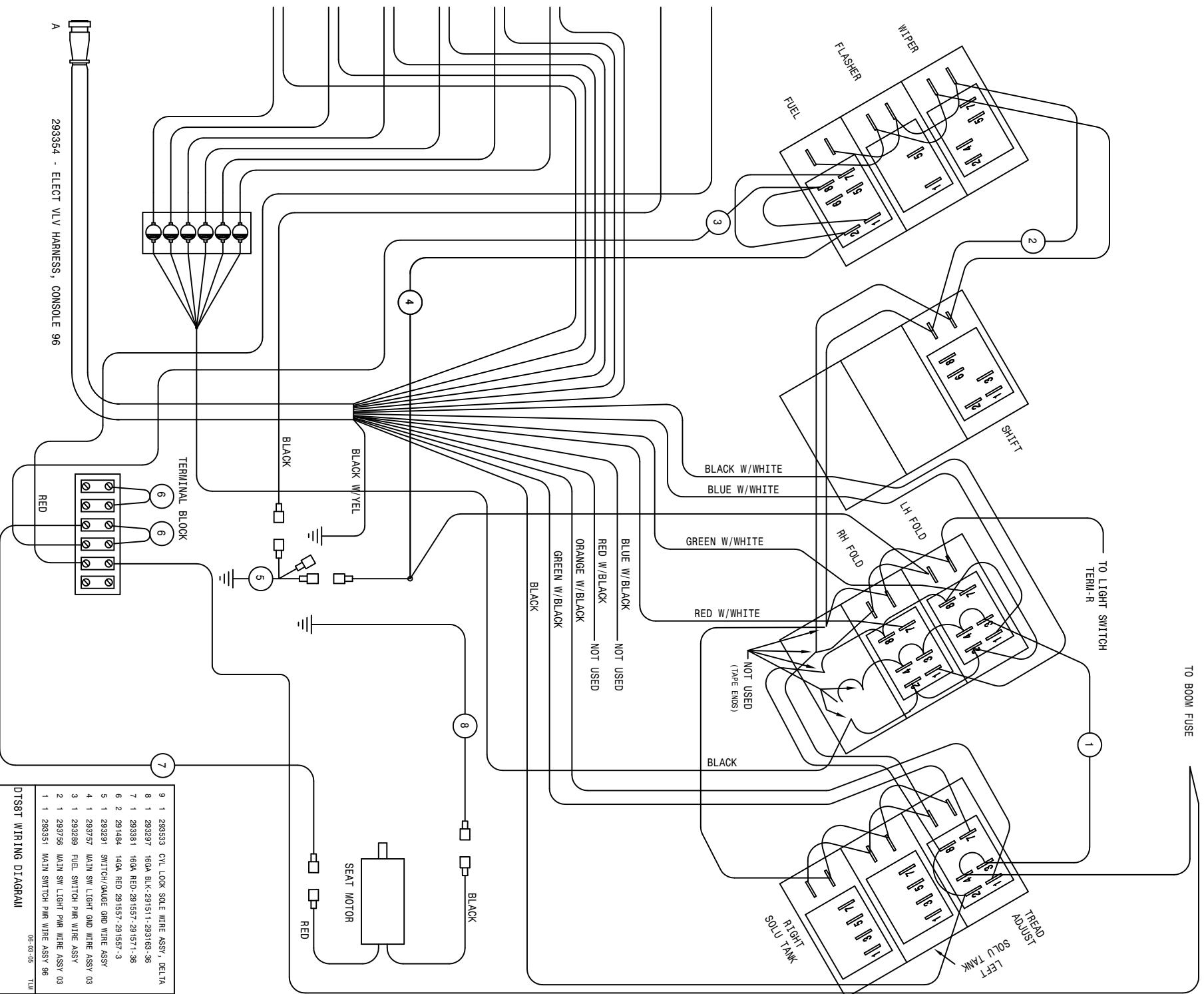

A 293354 - ELECT VLV HARNESS, CONSOLE 96

9	1	293533	CYL LOCK SOLE WIRE ASSY, DELTA
8	1	293297	16GA BLK-291511-293169-36
7	1	293381	16GA RED-291557-291571-36
6	2	291484	14GA RED-291557-291557-3
5	1	293291	SWITCH/GAUGE GND WIRE ASSY
4	1	293757	MAIN SW LIGHT GND WIRE ASSY 03
3	1	293289	FUEL SWITCH PWR WIRE ASSY
2	1	293756	MAIN SW LIGHT PWR WIRE ASSY 03
1	1	293351	MAIN SWITCH PWR WIRE ASSY 96

DTS81 WIRING DIAGRAM  
 SHEET 3 OF 5  
 REVISION DATE: 06-03-05 TLM  
 498890

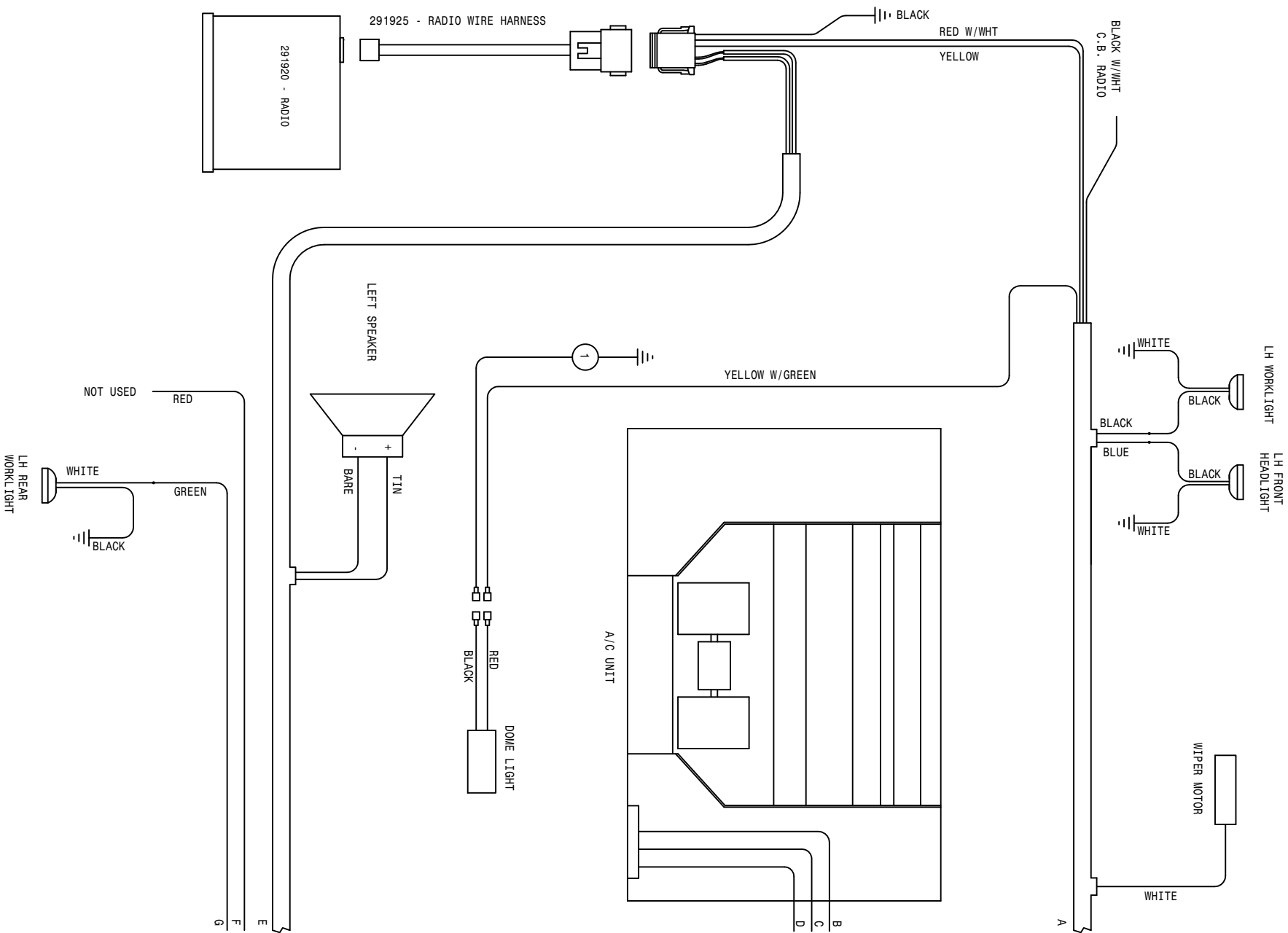

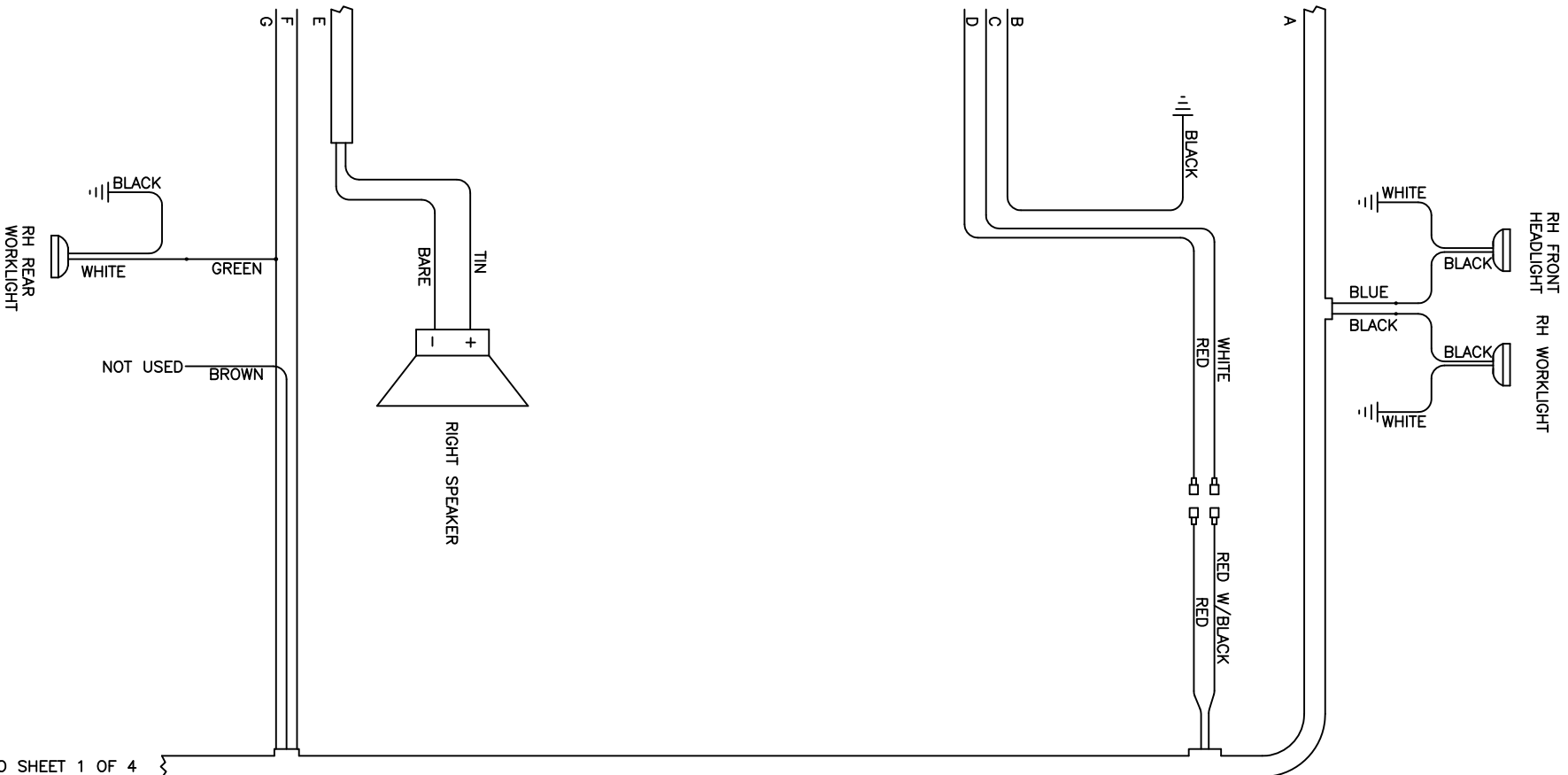

REFER TO SHEET 1 OF 4

293826 - CAB WIRE HARNESS 204/DTS8 05

1	1	293299	1604	BLK-291511-291571-30	06-03-05	TJM
DTS8T WIRING DIAGRAM						
SHEET 4 OF 5						4988890
REVISION DATE:						

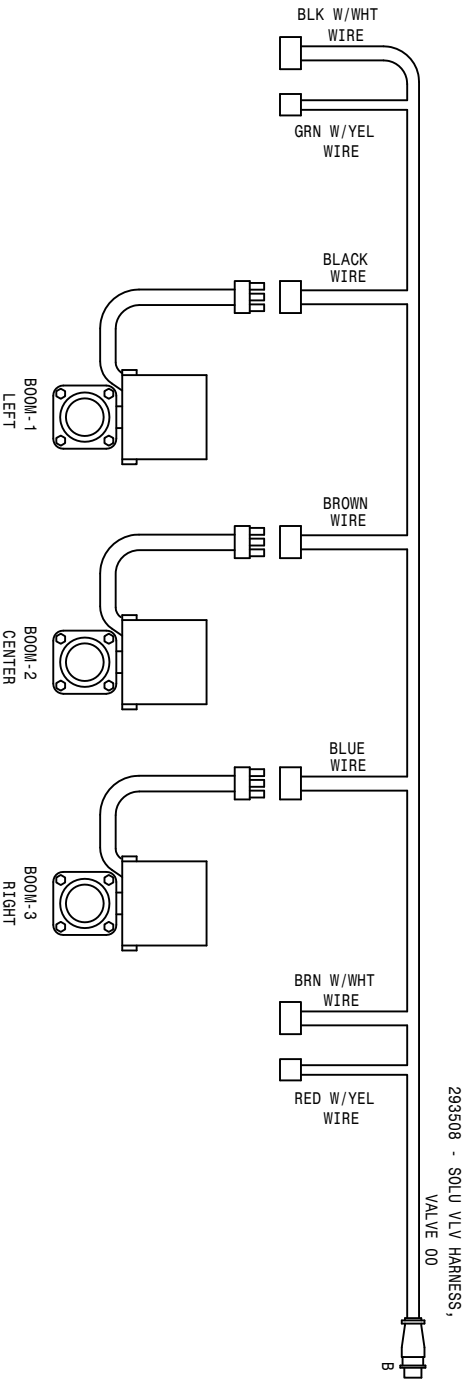
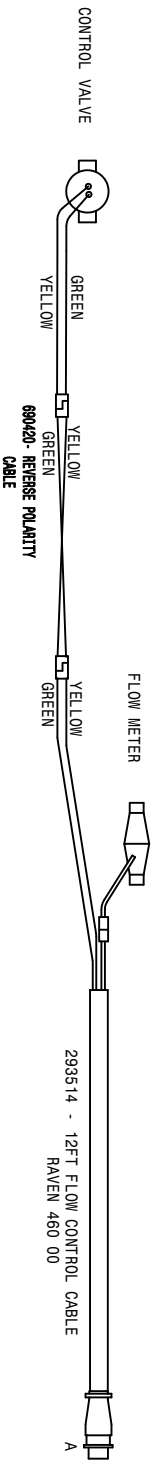

SOLUTION SOLENOID VALVES  
60 FOOT BOOM



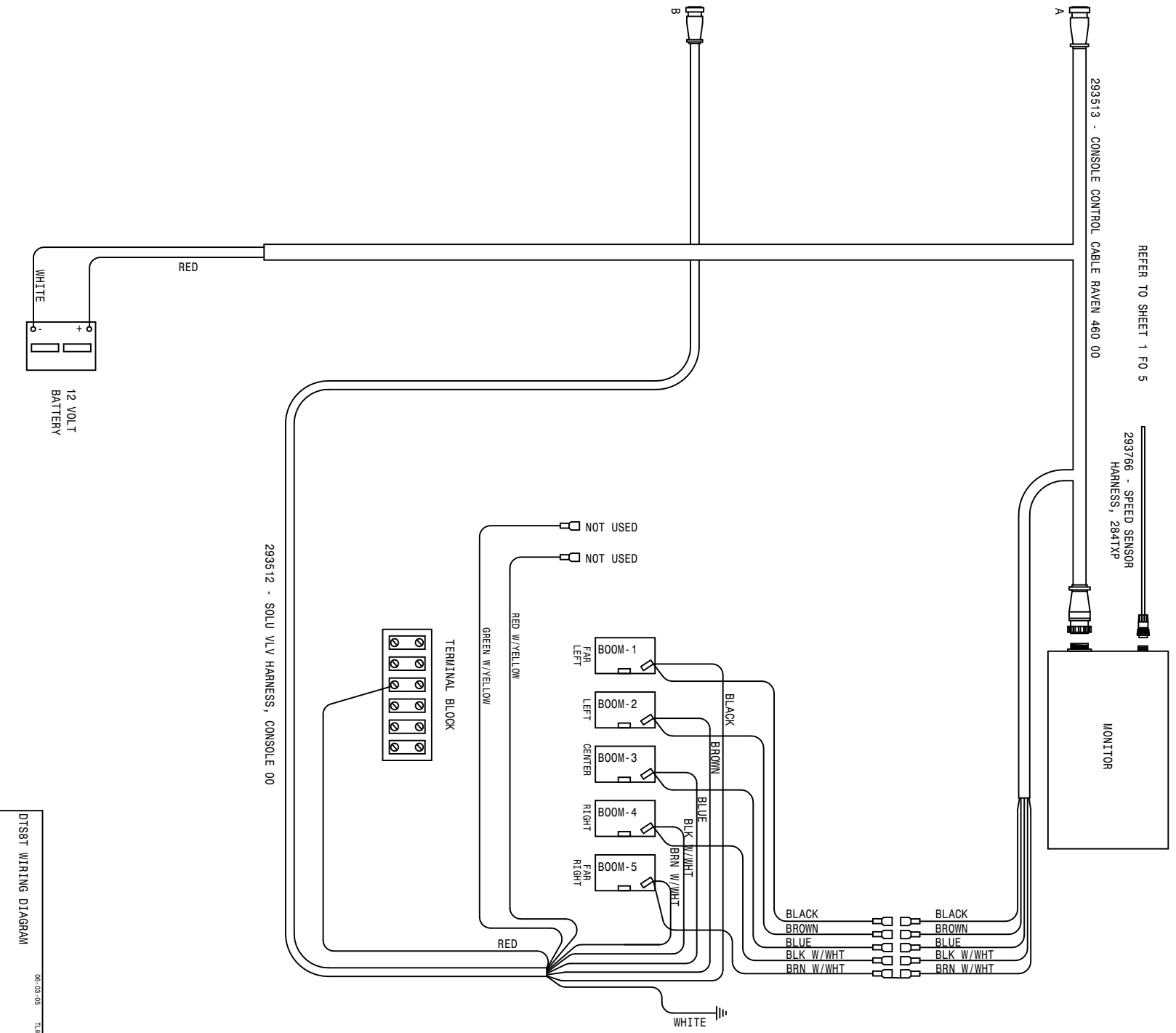

DTS8T WIRING DIAGRAM  
 SHEET 5 OF 5  
 REVISION DATE:  
 4988890

ABBREVIATIONS

A/C - AIR CONDITIONER	MT - MOUNT
ADPTR - ADAPTER	MTR - MOTOR
AGI - AGITATOR	P/N - PART NUMBER
ALT - ALTERNATOR	PLT - PLATE
ASSY - ASSEMBLY	QTY - QUANTITY
BRKT - BRACKET	RED - REDUCER
DET - DETAIL	REF - REFERENCE
DISPL - DISPLACEMENT	REST - RESTRICTOR
EL - ELBOW	REQ - REQUIRED
EXT - EXTENSION	SHFT - SHAFT
FLO - FLOW	SOL - SOLUTION
FNPT - FEMALE NATIONAL PIPE THREAD	STRG - STEERING
FOR - FEMALE O-RING	ST - STREET
FRT - FRONT	SWIV - SWIVEL
HYD - HYDRAULIC	UNC - UNIFIED NATIONAL COURSE
HYDRO - HYDROSTATIC	UNF - UNIFIED NATIONAL FINE
LG - LONG	V - VOLT
LWR - LOWER	W/ - WITH
MJIC - MALE J.I.C.	WHL - WHEEL
MOR - MALE O-RING	WLD - WELDMENT

INDEX

-A-

ABBREVIATIONS.....90  
 ACCUMULATOR CYLINDER.....60  
 ADJUSTMENT, TREAD.....66  
 AGITATOR  
     IMPELLER.....51, 53  
     SHAFT.....51, 53  
     SHIELD.....51, 53  
     SOLUTION.....51, 53  
 AIR CLEANER.....14  
     BAND.....14  
     FILTER.....14  
     HOOD.....14  
     HOSE.....14  
 AIR CONDITIONER  
     BLOWER MOUNT.....30  
     COMPRESSOR.....12  
     COMPRESSOR MOUNT.....12  
     CONDENSOR.....12  
     CONTROL.....30  
     DRYER.....12  
     FILTER.....30  
     AIR SEAT.....38  
     AIR TANK.....8, 9  
     ANTENNA, RADIO.....30  
     ARM,  
         TANK SUPPORT.....49  
         WIPER.....28

-B-

BALL VALVE.....50, 52  
 BAND,  
     AIR CLEANER.....14  
     FUEL TANK.....47  
     TANK.....50, 52  
 BATTERY.....27  
     BOX.....27  
     CABLE.....27  
     BELT.....5, 12  
     BINDING POST.....39  
     BLADE,  
         FAN.....5  
         WIPER.....28  
     BLOCK, TERMINAL.....35  
     BOOM.....64, 65  
     CONTROL VALVE.....57  
     CRADLE.....43  
     PIVOT PIN.....59  
     SPRING.....64

BRACE,  
     LADDER.....46  
     LEG.....49  
 BRAKE SOLENOID.....41  
 BREAKAWAY.....59  
 BREAKER, CIRCUIT.....35  
 BREATHER.....16

-C-

CAB.....28  
     ROOF.....28  
 CABLE,  
     BATTERY.....27  
     CONTROL.....35, 36, 37, 42  
     THROTTLE.....4  
 CAP,  
     FUEL.....47  
     RADIATOR.....13  
     STEERING.....32  
 CATWALK.....48  
 CIRCUIT BREAKER.....35  
 COMPRESSOR, A/C.....12  
 CONDENSOR.....12  
     MOUNT.....12  
     CONSOLE.....35  
     COVER.....34  
     CONTROL HANDLE.....36  
     COOLER, OIL.....13  
     CRADLE.....50, 52  
     BOOM.....43  
 CYLINDER,  
     ACCUMULATOR.....60  
     FOLD.....63  
     LEVEL.....62  
     LIFT.....61  
     STEERING.....26  
     TREAD ADJUSTMENT.....68

-D-

DECALS.....72, 73  
 DIAGRAM, WIRING.....80  
 DIFFUSER, LINE SUMP.....16  
 DIMMER SWITCH.....28  
 DIPSTICK.....16

DOOR.....29  
 HANDLE.....29  
 DRINK HOLDER.....35  
 DRIVE ASSEMBLY.....4  
 DRYER, A/C.....12

-E-

ENGINE.....4, 5  
 HOOD.....44  
 MOUNTS.....4, 5  
 EXHAUST PIPE.....14

-F-

FAN  
 BLADE.....5  
 SPACER.....5  
 FILTER,  
 AIR CLEANER.....14  
 AIR CONDITIONER.....30  
 FUEL.....4  
 HI-PRESS.....11  
 INLINE HYDRAULIC.....57  
 MICHIGAN.....16  
 MINDER.....33  
 OIL.....5, 16  
 FLASHER LIGHT.....43  
 FLASHER SWITCH.....32  
 FLOORMAT.....31  
 FLOW CONTROL  
 VALVE.....55  
 VARIABLE.....42  
 FLOW DIVIDER.....7  
 FLOW METER.....55  
 FLUSHING VALVE.....10  
 FOAM.....13, 31  
 FOLD CYLINDER.....59, 63  
 FUEL

CAP.....47  
 GAUGE.....33  
 SELECTOR VALVE.....47  
 SENDER.....47  
 TANK.....47  
 FUSE.....34  
 HOLDER.....34

-G-

GAUGE,  
 FUEL.....33  
 OIL PRESSURE.....33  
 PRESSURE.....56  
 SIGHT.....52

TEMPERATURE.....33  
 GAS SPRING.....29  
 GLASS.....28, 29  
 GLAND PACKING.....51, 53  
 GRAB HANDLE.....28  
 GROUND STRAP.....4, 27, 28

-H-

HANDLE,  
 CONTROL.....36  
 DOOR.....29  
 GRAB.....28  
 HANDRAIL.....44, 48  
 HEADLIGHT.....28  
 HEADLINER.....30  
 HEAT SHIELD.....13  
 HI-PRESS  
 FILTER.....11  
 HOLDER, DRINK.....35  
 HOOD,  
 AIR CLEANER.....14  
 ENGINE.....44  
 HOOK, RUBBER.....44  
 HOSE, AIR CLEANER.....14  
 HOSE, SOLUTION.....70  
 HOUR METER.....33  
 HUB, TORQUE.....19, 21, 23, 25  
 HYDRAULIC  
 SCHEMATIC.....74  
 TANK.....16  
 TUBE.....15, 19, 21, 23, 25, 58

-I-

IMPELLER.....51, 53  
 INDICATOR, MPH-RPM.....33  
 INLINE HYDRAULIC FILTER.....57  
 INTERIOR LIGHT.....30

-K-

KICK PANEL.....28  
 KNOB.....34, 35

-L-

LADDER.....46  
 LEG,  
 BRACE.....49  
 FRONT.....18, 19, 20, 21  
 REAR.....22, 23, 24, 25  
 LEVEL CYLINDER.....59, 62

LEVER, HYDROSTATIC..... 36  
 THROTTLE..... 37  
 LID..... 50, 52  
 LIFTARM..... 58  
 MOUNT..... 58  
 LIFT CYLINDER..... 58  
 LIGHT,  
 HEAD..... 28  
 INTERIOR..... 30  
 SWITCH..... 34  
 TURN SIGNAL..... 43  
 LINE SUMP DIFFUSER..... 16

-M-

METER, HOUR..... 33  
 MIRROR..... 28  
 MOTOR  
 STEERING..... 32  
 WHEEL..... 19, 21, 23, 25  
 WIPER..... 28  
 MOUNT,  
 A/C BLOWER..... 30  
 CONDENSOR..... 12  
 ENGINE..... 4, 5  
 FLOW DIVIDER..... 7  
 LIFTARM..... 58  
 MONITOR..... 39  
 RADIATOR..... 13  
 RUBBER..... 4, 5, 28  
 SOLUTION VFC..... 42  
 TANK..... 49  
 MUFFLER..... 14  
 MULLION..... 44

-N-

NOZZLE,  
 DROP..... 69  
 NYLON SLEEVE..... 18, 20, 22, 24

-O-

OIL  
 COOLER..... 13  
 FILTER..... 5  
 PRESSURE GAUGE..... 33  
 SENDER..... 4  
 TANK..... 16

-P-

PANEL, KICK..... 28  
 PARK BRAKE SWITCH..... 40  
 PIVOT PIN, BOOM..... 59  
 PLATFORM, SERVICE..... 48  
 POWER POINT..... 40  
 PRESSURE GAUGE..... 56  
 PUMP,  
 SOLUTION..... 54  
 SUNDSTRAND..... 6

-R-

RADIATOR..... 13  
 CAP..... 13  
 HOSE..... 5  
 MOUNT..... 13  
 SCREEN..... 13  
 SHROUD..... 13  
 RADIO..... 30  
 RECOVERY..... 13  
 RELAY..... 36  
 RELIEF VALVE..... 7  
 RIM..... 17  
 ROOF, CAB..... 28  
 RUBBER,  
 HOOK..... 45  
 MOUNT..... 4, 5, 28  
 WASHER..... 7, 41

-S-

SCHEMATIC, HYDRAULIC..... 74  
 SCREEN..... 45  
 RADIATOR..... 13  
 SEAT..... 39  
 SELECTOR VALVE, FUEL..... 47  
 SENDER,  
 FUEL..... 47  
 OIL..... 4  
 TEMPERATURE..... 5  
 SERVICE PLATFORM..... 48  
 SHAFT, AGITATOR..... 51, 53  
 SHEETMETAL..... 44, 45  
 SHIELD,  
 AGITATOR..... 51, 53  
 HEAT..... 13  
 SIDE..... 45  
 TANK..... 49  
 WHEEL MOTOR..... 19, 21, 23, 25  
 SHROUD, RADIATOR..... 13

SIGHT GAUGE.....50, 52  
 SMV SIGN.....48  
 SOLUTION  
 AGITATOR.....51, 53  
 HOSEING.....70  
 PUMP.....54  
 TANK.....50, 52  
 SPACER, FAN.....5  
 SPEAKER.....30  
 SPRING.....37  
 BOOM.....64  
 STALK GUIDE.....19, 21, 23, 25  
 STEERING  
 ARM.....18, 20, 22, 24  
 CAB.....32  
 CYLINDER.....26  
 MOTOR.....32  
 POST.....32  
 WHEEL.....32  
 STRAINER.....50, 52  
 STRAP, GROUND.....4, 27, 28  
 SUNDSTRAND PUMP.....6  
 SUPPORT ARM.....49  
 SWITCH  
 DIMMER.....28  
 FLASHER.....32  
 LIGHT.....34  
 PARK BRAKE.....40  
 TOGGLE.....34

-T-

TAILLIGHT.....48  
 TANK,  
 AIR.....8, 9  
 BAND.....50, 52  
 FUEL.....47  
 HYDRAULIC OIL.....16  
 LID.....50, 52  
 MOUNTS.....49  
 RECOVERY.....13  
 SHIELD.....49  
 SOLUTION.....50, 52  
 TEMPERATURE  
 GAUGE.....33  
 SENDER.....5  
 TERMINAL BLOCK.....35  
 THROTTLE  
 CABLE.....4  
 LEVER.....37  
 TIRE.....17

TOGGLE SWITCH.....34  
 TORQUE HUB.....19, 21, 23, 25  
 TRANSOM.....59  
 TREAD ADJUSTMENT.....66  
 CYLINDER.....68  
 TUBE,  
 HYDRAULIC.....58  
 4WD.....41  
 TURN SIGNAL LIGHT.....43

-V-

VALVE,  
 BALL.....50, 52  
 BOOM CONTROL.....56  
 ELECTRIC SOLUTION.....50, 52  
 FLOW CONTROL.....55  
 FLUSHING.....10  
 RELIEF.....7  
 4WD.....41  
 VARIABLE FLOW CONTROL.....42  
 VOLTMETER.....33

-W-

WEATHER STRIP, WINDOW.....28, 29  
 WHEEL MOTOR.....19, 21, 23, 25  
 SHIELD.....19, 21, 23, 25  
 WHEEL, STEERING.....32  
 WINDSHIELD WASHER.....40  
 WIPER  
 ARM.....28  
 BLADE.....28  
 MOTOR.....28  
 WIRING DIAGRAM.....80

# HAGIE PARTS ORDER FAX



Ph. 1 (800) 247-4885

Fx. 1 (515) 532-3553

Photocopy and fax to Hagie Customer Support Department

ORDERED BY/BILL TO:

Name \_\_\_\_\_  
 Co. Name \_\_\_\_\_  
 Street \_\_\_\_\_  
 City, St, Zip \_\_\_\_\_  
 Ph. \_\_\_\_\_ Fx. \_\_\_\_\_

SHIP TO:

Name \_\_\_\_\_  
 Co. Name \_\_\_\_\_  
 Street \_\_\_\_\_  
 City, St, Zip \_\_\_\_\_  
 Ph. \_\_\_\_\_ Fx. \_\_\_\_\_

HOW SHIP:  UPS Ground  Next Day  2 Day  3 Day  Other \_\_\_\_\_

If "HOW SHIP" is left blank, parts will be sent UPS ground service. If part is over 150 pounds, an independent motor freight company will be used.

PAYMENT:  Hagie Account #\*\*\* \_\_\_\_\_

C.O.D

American Express  Discover  Visa  Master Card  
 Signature: \_\_\_\_\_  
 name as appears on card: \_\_\_\_\_  
 card no. \_\_\_\_\_ exp. date \_\_\_\_\_

Year and Model No. \_\_\_\_\_

Serial No. \_\_\_\_\_

Item Serial No. (if necessary): \_\_\_\_\_

Engine (include type) \_\_\_\_\_

Hydrostatic Pump (s) \_\_\_\_\_

Torque Hub \_\_\_\_\_  LF  RF  LR  RR

Wheel Motor \_\_\_\_\_  LF  RF  LR  RR

HAGIE Part No.	Qty.	Description

Check here if you want phone confirmation of parts order.

\* Orders received before 3:00 p.m., CST will be processed the same business day.  
 Regular business hours are Monday through Friday, 7:00 a.m. through 5:00 p.m..  
 \*\* If you do not have a Hagie account number, contact the Hagie Customer Support Department and you will be issued one.

# HAGIE PARTS ORDER FAX

**Fax**  
**24 hours**  
**a day**  
**7 days**  
**a week\*\***

Ph. 1 (800) 247-4885

Fx. 1 (515) 532-3553

Photocopy and fax to Hagie Customer Support Department

ORDERED BY/BILL TO:

Name \_\_\_\_\_  
Co. Name \_\_\_\_\_  
Street \_\_\_\_\_  
City, St, Zip \_\_\_\_\_  
Ph. \_\_\_\_\_ Fx. \_\_\_\_\_

SHIP TO:

Name \_\_\_\_\_  
Co. Name \_\_\_\_\_  
Street \_\_\_\_\_  
City, St, Zip \_\_\_\_\_  
Ph. \_\_\_\_\_ Fx. \_\_\_\_\_

HOW SHIP:  UPS Ground  Next Day  2 Day  3 Day  Other \_\_\_\_\_

If "HOW SHIP" is left blank, parts will be sent UPS ground service. If part is over 150 pounds, an independent motor freight company will be used.

PAYMENT:  Hagie Account #\*\* \_\_\_\_\_

C.O.D

American Express  Discover  Visa  Master Card  
Signature: \_\_\_\_\_  
name as appears on card: \_\_\_\_\_  
card no. \_\_\_\_\_ exp. date \_\_\_\_\_

Year and Model No. \_\_\_\_\_

Serial No. \_\_\_\_\_

Item Serial No. (if necessary): \_\_\_\_\_

Engine (include type) \_\_\_\_\_

Hydrostatic Pump (s) \_\_\_\_\_

Torque Hub \_\_\_\_\_  LF  RF  LR  RR

Wheel Motor \_\_\_\_\_  LF  RF  LR  RR

HAGIE Part No.	Qty.	Description

Check here if you want phone confirmation of parts order.

\* Orders received before 3:00 p.m., CST will be processed the same business day.

Regular business hours are Monday through Friday, 7:00 a.m. through 5:00 p.m..

\*\* If you do not have a Hagie account number, contact the Hagie Customer Support Department and you will be issued one.