

**CALIFORNIA  
Proposition 65 Warning**

Diesel engine exhaust and some of its constituents are known to the State of California to cause cancer, birth defects, and other reproductive harm.

**2020 DTS10  
OPERATOR'S MANUAL  
493828**





**HAGIE**  
**CONTENTS**

---

## **1 – INTRODUCTION**

A Word From Hagie Manufacturing Company .....	1-1
About This Manual .....	1-1
Safety Messages Used In This Manual .....	1-2
Service and Assistance .....	1-2
Product Warranty .....	1-3
Identification .....	1-3
Sound Level .....	1-4
Whole Body Vibration .....	1-4
Specifications .....	1-6
Torque Values .....	1-17

## **2 – SAFETY AND PRECAUTIONS**

Intended Use .....	2-1
Safety Precautions .....	2-1
Seat Belt .....	2-7
Rotating Beacon .....	2-7
Emergency Stop .....	2-7
Emergency Exit .....	2-8
Fire Extinguisher .....	2-9
Safety Decals .....	2-9

## **3 – CAB**

Seat - Operator (Standard) .....	3-1
Seat - Operator (Premium) .....	3-4
Seat - Instructor .....	3-7
Operator's Station .....	3-7
Machine Display .....	3-32

## **4 – ENGINE AND DRIVE SYSTEMS**

Engine - Starting .....	4-1
Engine Aftertreatment - Final Tier 4 .....	4-3
Hydrostatic Drive .....	4-10
All-Wheel Steer (AWS) .....	4-15

## **5 – HYDRAULIC SYSTEMS**

Hydraulic System Components .....	5-1
Reversible Fan - Variable Pitch .....	5-4
Tread Adjustment - Hydraulic .....	5-6
Ladder .....	5-9
Pressure Washer .....	5-10

---

## 6 – ELECTRICAL SYSTEMS

Batteries .....	6-1
Battery Disconnect Switch .....	6-2
Fuses and Relays .....	6-4
Fuse and Relay Ratings .....	6-8

## 7 – SPRAY SYSTEMS

Spray Booms .....	7-1
Spray Boom - Rear .....	7-14
Solution System Components .....	7-16
Solution System - Operation .....	7-25
Fence Row Applicator .....	7-29
Filling Your Solution Tanks .....	7-30
Draining Your Solution Tanks .....	7-33
Rinse System .....	7-34
Solution Pump Re-Priming .....	7-38
Foam Marker System .....	7-42
Eductor System .....	7-45
Modular Injection System .....	7-49
Application .....	7-59

## 8 – MAINTENANCE AND STORAGE

Service - Fluids .....	8-1
Service - Filters .....	8-11
Service - Lubrication .....	8-22
Service - Engine Drive Belt .....	8-24
Service - Bolt Torque .....	8-24
Service - Toe-In .....	8-27
Service - Miscellaneous .....	8-29
Service Intervals .....	8-34
Storage .....	8-36

## 9 – MISCELLANEOUS

Transporting .....	9-1
TOWING .....	9-3
Lifting Your Machine .....	9-5
Air Suspension Exhaust .....	9-7
Viscous Clutch Fan .....	9-8
Hand Wash System .....	9-9
Electric Hood .....	9-11
Front End Access .....	9-12
Tread Adjustment - Manual .....	9-13
Tall Crop Package - Installation .....	9-16
Troubleshooting .....	9-23

---



## SECTION 1 – INTRODUCTION

---

### A WORD FROM HAGIE MANUFACTURING COMPANY

Congratulations on the purchase of your DTS10 Sprayer! Read this operator's manual and become familiar with operating procedures and safety precautions before attempting to operate your sprayer.

As with any piece of equipment, certain operating procedures, service, and maintenance are required to keep your machine in top running condition. We have attempted herein to cover all of the adjustments required to fit varying conditions. However, there may be times when special care must be considered.

*NOTE: The operator is responsible for inspecting the machine and having parts repaired or replaced when continued use of the product causes damage or excessive wear to other parts.*

Hagie Manufacturing Company reserves the right to make changes in the design and material of any subsequent sprayer without obligation to existing units.

Thank you for choosing a Hagie sprayer and we ensure you of our continued interest and support in its optimal performance for you. We are proud to have you as a customer!

### ABOUT THIS MANUAL

#### NOTICE

Any pictures or illustrations contained within this manual that depict situations with shields, guards, rails, or lids removed are for demonstration only. Keep all shields and safety devices in place at all times.

This manual will aid you in the proper operation and service of your machine. It is the responsibility of the user to read the operator's manual and comply with the correct and safe operating procedures, as well as maintain the product according to the service information provided in the *Maintenance and Storage Section* elsewhere in this manual.

Photographs and illustrations used in this manual are of general nature only. Some of the equipment and features shown may not be available on your machine.

Information described in this manual was correct at the time of printing. Because of Hagie Manufacturing Company's continuous product improvement, certain information may not be included in this manual. To obtain the most current operator's manual for your machine, please visit [www.hagie.com](http://www.hagie.com).

Keep this manual in a convenient place for easy reference. This manual is considered a permanent fixture of the product. In the event of resale, this manual must accompany the machine.

If you do not understand any part of this manual or require additional information or service, contact your local John Deere dealer for assistance.

## **SAFETY MESSAGES USED IN THIS MANUAL**

The following safety messages found throughout this manual alert you of situations that could become potentially dangerous to the operator, service personnel, or equipment.

**⚠ DANGER**

The signal word DANGER indicates a hazardous situation which, if not avoided, will result in death or serious injury.

**⚠ WARNING**

The signal word WARNING indicates a hazardous situation which, if not avoided, could result in death or serious injury.

**⚠ CAUTION**

The signal word CAUTION indicates a hazardous situation which, if not avoided, could result in minor or moderate injury. CAUTION may also be used to alert against unsafe practices associated with events which could lead to personal injury.

**NOTICE**

The signal word NOTICE indicates operator awareness which, if not avoided, may result in personal or property damage.

*NOTE: A “Note” is intended to make special mention of, or remark on.*

## **SERVICE AND ASSISTANCE**



### **John Deere Is At Your Service**

Customer satisfaction is important to Hagie and John Deere. Our dealers strive to provide you with prompt, efficient parts and service:

- Maintenance and service parts to support your equipment.
- Trained service technicians and the necessary diagnostic and repair tools to service your equipment.

### **Customer Satisfaction Problem Resolution Process**

Your John Deere dealer is dedicated to supporting your equipment and resolving any problem you may experience.

1. When contacting your dealer, be prepared with the following information:
  - Machine model and product identification number.
  - Date of purchase.
  - Nature of problem.
2. Discuss problem with dealer service manager.
3. If unable to resolve, explain problem to dealership manager and request assistance.
4. If you have a persistent problem your dealership is unable to resolve, ask your dealer to contact John Deere for assistance, or contact the Ag Customer Assis-

tance Center at 1-866-99DEERE (866-993-3373) or e-mail us at [www.deere.com/en\\_US/ag/contactus](http://www.deere.com/en_US/ag/contactus).

---

## PRODUCT WARRANTY

Please contact your local John Deere dealer for further information.

---

## IDENTIFICATION

### NOTICE

Reference to right and left-hand used throughout this manual refers to the position when seated in the operator's seat facing forward.

Each machine is identified by means of a frame serial number. This serial number denotes the model, year in which it was built, and the number of the sprayer.

For further identification, the engine, solution pump, and hydraulic pumps each have serial numbers, and the planetary wheel motor/hubs have identification plates that describe the type of mount and gear ratio.

To ensure prompt, efficient service when ordering parts or requesting service repairs, record the serial numbers and identification numbers in the following spaces provided.

### Machine

The machine serial number is stamped on the front right-hand side of frame (behind the front leg).



Machine Serial Number  
-Typical View

Serial No. \_\_\_\_\_

### Engine

The engine has an identification plate mounted on top of the engine that provides engine serial number, as well as other manufacturer information. Refer to your Parts Manual for specific part number.

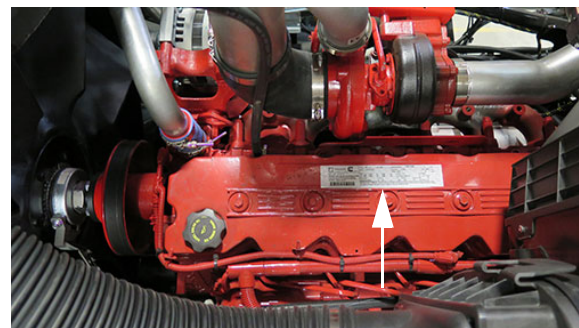

Engine Identification Plate  
-Typical View

Serial No. \_\_\_\_\_

### Solution Pump

The solution pump has an identification plate mounted on the side of pump that provides pump serial number, as well as other manufacturer information. Refer to your Parts Manual for specific part number.



**Solution Pump Identification Plate**  
\* View shown from beneath machine  
-Typical View

Serial No. \_\_\_\_\_

### Hydraulic Pumps

The PC and Drive Pumps each have an identification plate mounted on the side of pump that provides pump serial number, as well as other manufacturer information. Refer to your Parts Manual for specific part number.

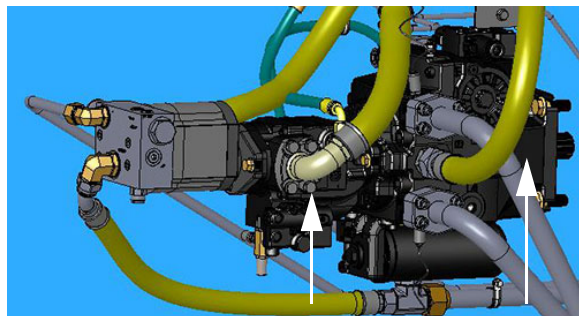

• PC Pump      • Drive Pump

**Hydraulic Pumps**  
-Typical View

\_\_\_\_\_ PC Pump

\_\_\_\_\_ Drive Pump

### Wheel Motor/Hubs

Each wheel motor/hub assembly has an identification plate mounted on the rear side of the hub that provides serial number, as

well as other manufacturer information, including gear ratio. Refer to your Parts Manual for specific part number.

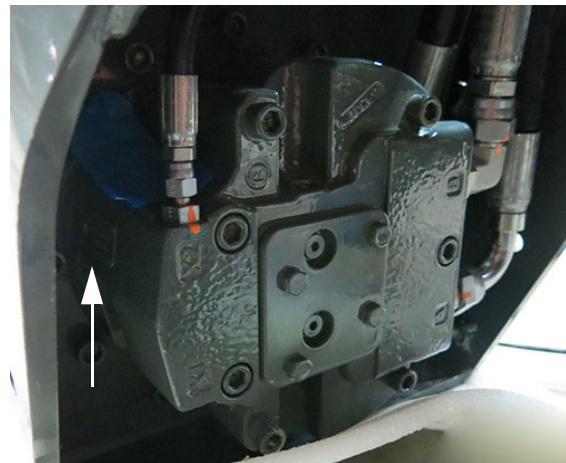

**Wheel Motor/Hub Assembly**  
-Typical View

\_\_\_\_\_ Right Front

\_\_\_\_\_ Right Rear

\_\_\_\_\_ Left Front

\_\_\_\_\_ Left Rear

### SOUND LEVEL

The highest A-weighted sound pressure level inside the operator's station range from 74.6 dB(A) to 75.5 dBA as measured in accordance with ISO 5131. These sound pressure levels depend on the speed at which the machine is operated, the maintenance of the machine, and the operator's experience and operational habits.

### WHOLE BODY VIBRATION

The weighted root mean square acceleration to which the whole body is subjected to ranges from 0.42 to 0.59 m/s<sup>2</sup> as measured on a representative machine during typical operations and analyzed in accordance with ISO 2631. During the same



operations, the weighted root mean square hand-arm vibration is subjected to ranges from 0.21 to 0.59 m/s<sup>2</sup> when analyzed in accordance with ISO 5349. These acceleration levels depend on the roughness of the ground, the speeds at which the machine is operated, the maintenance of the machine and the operator's experience, weight, and driving habits.

## SPECIFICATIONS

### Machine Dimensions

*NOTE: Dimensions on your machine may vary, depending on tire size.*

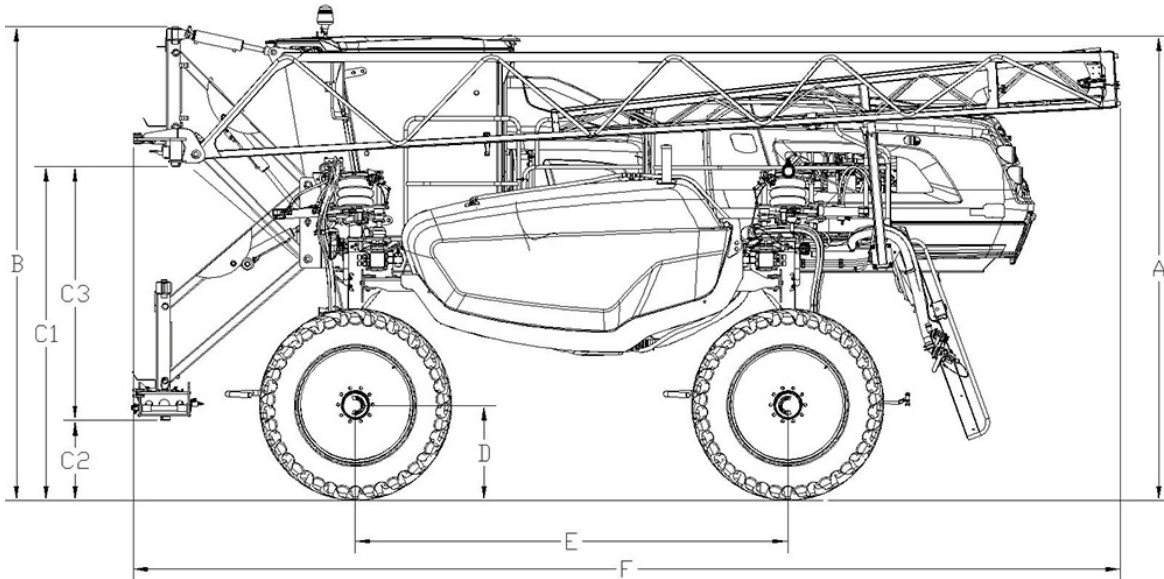

Detail	Description	Specification
A	Overall Sprayer Height (from top of cab) <i>NOTE: Overall machine height dimension does not include the cab-mounted rotating beacons or the optional GPS unit.</i>	<ul style="list-style-type: none"> <li>• 149.5"/379.3 cm (air bags inflated) **</li> <li>• 144"/365.8 cm (air bags deflated) **</li> </ul>
B	Raised Transom Height	150.8"/383 cm **
C1	Transom Height - Fully Raised	106"/269.2 cm
C2	Transom Height - Fully Lowered	24"/61 cm
C3	Transom Lift Range (C1 minus C2)	82"/208.3 cm
D	Static Loaded Hub Height	28.6"/72.6 cm **
E	Wheel Base	139.4"/354.1 cm
F	Sprayer Length <i>NOTE: Overall machine length does not include the optional rear boom.</i>	326"/828 cm
G	Width (booms folded)	156"/396.2 cm
H	Frame Clearance (to mainframe)	72"/182.9 cm **
I	Lower Leg Clearance	23"/58.4 cm **
J	Tread Width*	<ul style="list-style-type: none"> <li>• In = 120"/304.8 cm **</li> <li>• Out = 160"/406.4 cm **</li> </ul>

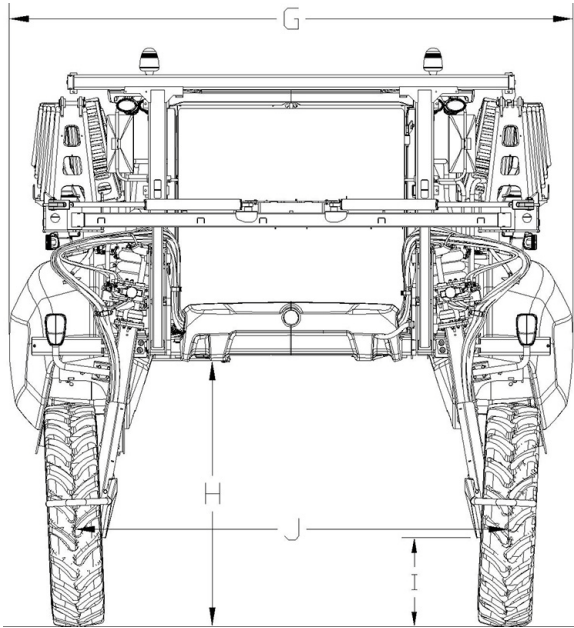

\* Tread width is measured from center of tire at ground.

\*\* Refer to “Tire Specifications” provided elsewhere in this section for a complete listing of tire options when configuring machine specifications on your model.

## General Information

### NOTICE

Because Hagie Manufacturing Company offers a variety of options, the illustrations in this manual may show a machine equipped other than standard. Machine dimension and weight values may vary, depending on available equipment.

- **Frame Type:** 3 x 8” (7.6 x 20.3 cm) modular platform frame
- **Suspension:** 4-wheel, individual, auto air-ride
- **Shipping Width:** 156”/396.2 cm (from outside of each solution tank)
- **Approximate Dry Weight:** 19,654 lbs./8,914 kg

**SECTION 1 –  
INTRODUCTION**



**Spray System GPS Specifications  
-If Equipped**

*NOTE: Dimensions on your machine may vary, depending on tire size.*

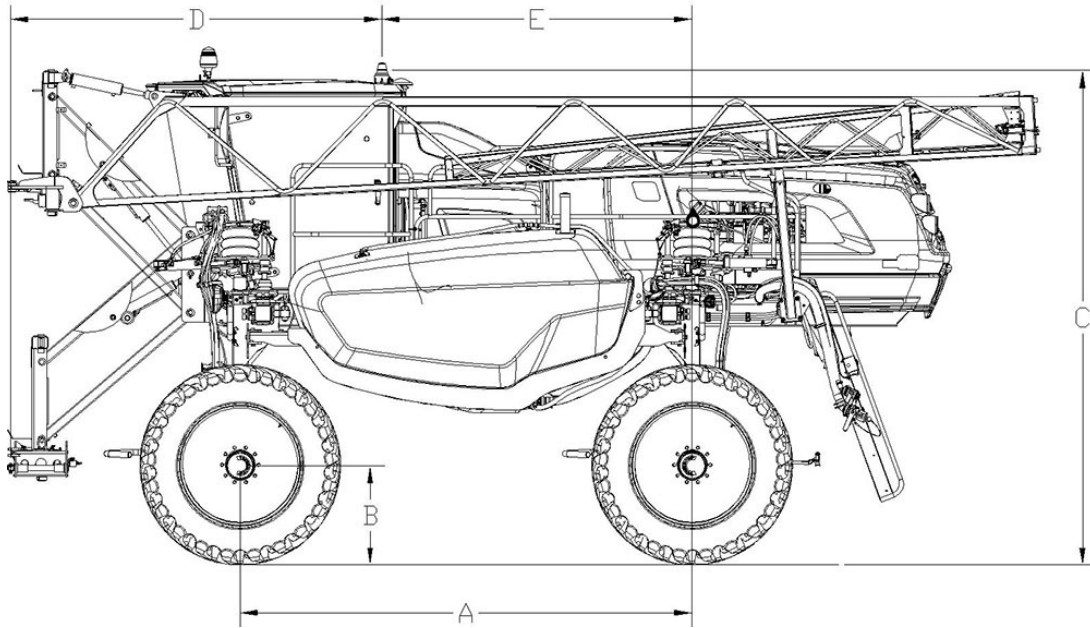

Detail	Description	Specification
A	Wheel Base	139.4" (354.1 cm)
B	Static Loaded Hub Height	28.6" (72.6 cm)
C	Overall Sprayer Height (from middle of GPS unit)	152.1" (386.3 cm)
D	Length (from front of boom spray tips to center of GPS unit)	114" (289.6 cm)
E	Length (from center of GPS unit to center of rear hub)	97" (246.4 cm)



**Settings and Calibration**

Record settings and calibration values used in the following spaces provided when programming your spray system console. Refer to this information for future reference.

Record calculated calibration values in the spaces provided below.

Speed Cal	Section Widths	Meter Cal	Rate Cal	Valve Cal	Tank Volume
1.	1.	1.	1.	1.	1.
	2.	2.	2.	2.	2.
	3.	3.	3.	3.	3.
	4.	4.	4.	4.	4.
	5.	5.	5.	5.	5.
	6.				
	7.				
	8.				
	9.				
	10.				

**Machine Specifications**

Description	Specification
<b>Engine</b>	
<b>Manufacturer</b>	Cummins®
<b>Model</b>	QSB 6.7
<b>Type</b>	Electronic with air-to-air cooler and turbo charger
<b>Number of Cylinders</b>	6
<b>Displacement</b>	6.7 liters (408.9 c.i.)
<b>Horse Power</b>	<ul style="list-style-type: none"> <li>• <b>Final Tier 4</b> - 225 hp/165 KW</li> <li>• <b>Tier 3</b> - 215 hp/158 KW (Export only)</li> </ul>
<b>Fuel Type</b>	<ul style="list-style-type: none"> <li>• <b>Final Tier 4</b> - Ultra-low sulfur diesel (ULSD)</li> <li>• <b>Tier 3</b> - No. 2 diesel (Export only)</li> </ul>
<b>Fuel System</b>	Filtered, direct-injected
<b>Air Cleaner</b>	Dry-type, dual element
<b>Engine Air Filter Restriction Monitors</b>	Filter Minder®
<b>Slow Idle</b>	850 RPM
<b>Fast Idle (no load)</b>	2500 RPM
<b>Hydrostatic Drive</b>	
<b>Hydrostatic Pump</b>	Danfoss H1-Series
<b>Drive Train</b>	All-Wheel 4-Wheel Drive
<b>Speed Ranges</b>	<ul style="list-style-type: none"> <li>• Speed Range 1 (0-14 mph, 0-22.5 km/h)*</li> <li>• Speed Range 2 (0-20 mph, 0-32 km/h)*</li> <li>• Speed Range 3 (0-30 mph, 0-48 km/h)* - Road Mode only</li> </ul> <p style="margin-top: 5px;"><i>* Speed ranges may vary, depending on tire size.</i></p>
<b>Wheel Motors/Final Drive</b>	Fairfield Torque-Hub® (CT07)
• Lubrication	Oil bath
<b>Brakes (Parking)</b>	Multiple disk, spring applied, hydraulically released
<b>Auxiliary Hydraulic System</b>	
<b>Steering System</b>	Hydraulic, priority circuit
• Control	Full-time power
• Steering Cylinders	Double acting

<ul style="list-style-type: none"> <li>Turning Radius<sup>^</sup> (Measured from center point to center of tracks) <i>NOTE: May vary, depending on tire size.</i></li> </ul>	<ul style="list-style-type: none"> <li>12.04 ft./3.5 m (AWS “On”, if equipped)</li> <li>19.29 ft./5.5 m (No AWS/AWS “Off”)</li> </ul>
<b>All Wheel Steer (AWS) - if equipped<sup>^</sup></b>	Coordinated steering
<b>Solution System Hydraulic Pump</b>	Gear pump
<b>Spray System</b>	
<b>Booms</b>	<ul style="list-style-type: none"> <li>60/80-ft. (7 sections)</li> <li>60/90-ft. (7 sections)</li> </ul>
<ul style="list-style-type: none"> <li>Type</li> </ul>	0.5” (1.3 cm) schedule 5 stainless wet boom plumbing
<ul style="list-style-type: none"> <li>Controls</li> </ul>	Electro-hydraulic (fold/lift/level)
<ul style="list-style-type: none"> <li>Outer Boom Hydraulic Breakaway</li> </ul>	Self-actuated, reset electrically
<b>Solution Fill Connection</b>	
<ul style="list-style-type: none"> <li>Quick-fill Connection</li> </ul>	2” (5 cm) inner diameter
<b>Solution Tanks (2)</b>	500 gallons (1892 L)/each
<b>Agitation</b>	Jet-type with electric valve variable control
<b>General Spray System</b>	
<ul style="list-style-type: none"> <li>Pump</li> </ul>	<ul style="list-style-type: none"> <li>Centrifugal-hydraulically driven w/proportional control valve</li> <li>Hypro® 9303C-HM1C w/silicon carbide seals</li> </ul>
<ul style="list-style-type: none"> <li>Flow Meter</li> </ul>	<ul style="list-style-type: none"> <li>TeeJet® 802</li> <li>Turbine type with sapphire bearing</li> <li>Usable range = 3-130 GPM (11.4-492.7 l/min)</li> <li>Diagnostic LEDs for easy troubleshooting</li> </ul>
<ul style="list-style-type: none"> <li>Solution Valves</li> </ul>	Ball valves (electric)
<ul style="list-style-type: none"> <li>Pressure Gauge</li> </ul>	160 PSI (11 bar), glycerin filled
<ul style="list-style-type: none"> <li>Console</li> </ul>	<ul style="list-style-type: none"> <li>Raven (optional)</li> <li>Ag Leader® (optional)</li> <li>John Deere (optional)</li> </ul>
<ul style="list-style-type: none"> <li>Fence Row Nozzle</li> </ul>	Remote activated (left and right)
<ul style="list-style-type: none"> <li>Rear Wheel Nozzle</li> </ul>	Remote activated
<b>Solution Circuit Pressure</b>	100 PSI (6.9 bar) - maximum
<b>Modular Injection System (if equipped)</b>	
<b>Chemical Tank(s)</b>	45-gallons (170 L)/each
<b>Injection Pump(s)</b>	Raven Sidekick Pro™ (5-200 oz./min.)
<b>Mixer</b>	3” (7.6 cm) poly

**SECTION 1 –  
INTRODUCTION**



<b>Foam Marker System</b>	
<b>Make</b>	Hagie Concentrate Foamer
<b>Type</b>	Boom Mix
<b>Rinse System</b>	
<b>Spray System Rinse (solution tanks, pump, and booms)</b>	2 rotating rinse balls (inside each tank)
<b>Air Purge - if equipped</b>	Remote activated (purges downstream from flow meter through boom plumbing)
<b>Electrical System</b>	
<b>General Electrical System</b>	
• Battery	Dual 12V, negative ground (CCA)
• Alternator	200 AMP, voltage regulated
• Starter	12V with solenoid
<b>Lights (Exterior)</b>	
• Front of Cab	2 trapezoidal headlights, 2 floodlights, 2 rotating amber beacon lights
• Transom	2 trapezoidal headlights
• Transom Mount	2 trapezoidal headlights (high/low beam), 2 oval amber lights (combined)
• Tank Cradle	2 oval amber lights (1 on each cradle)
• Rear Engine Hood	2 round red lights, 2 round amber lights
• Spray Boom Indicators (located on boom, if equipped)	7 oval green lights
• Night Spray - if equipped	2 flood lights (rear of cab), 2 spot beam lights (facing boom tip)
<b>Cab and Instruments</b>	
<b>Sound Level (cab interior)</b>	74.6-75.5 dBa
<b>Cab (General)</b>	Tilt steering, wipers/washers, dual side mirrors, dome light, tinted glass, instructor seat
<b>Cab Door Width (opening width)</b>	22" (55.9 cm)
<b>Temperature Control</b>	Full range
<b>A/C Charge Type</b>	R-134A
<b>Fresh Air Filtration</b>	<ul style="list-style-type: none"> <li>• RESPA® cab filter</li> <li>• Charcoal filter</li> </ul>
<b>Seat</b>	<ul style="list-style-type: none"> <li>• Mechanical (standard)</li> <li>• Air-ride (optional)</li> </ul>





## SECTION 1 – INTRODUCTION

<b>Instruments</b>	Tachometer (RPM), fuel level, engine coolant temperature, after-treatment level
<b>Machine Display</b>	Hour meter, battery voltage, engine oil pressure, ground speed, engine diagnostics, tread adjustment, parking brake, machine/engine malfunction warnings, engine exhaust filtration warning, high exhaust temperature warning, low hydraulic oil level, low coolant level, low fuel level, grid heater, cab air pressure
<b>Stereo</b>	AM/FM radio, MP3, Bluetooth
<b>Fluid Capacities</b>	
<b>Solution Tanks (2)</b>	500 gallons (1892L)/each
<b>Fuel Tank</b>	100 gallons (378.5L)
<b>Engine Oil Pan (including filter and cooler)</b>	17.6 quarts (16.7L), John Deere Plus-50™ II
<b>Engine Oil Dipstick (L-H mark)</b>	2 quarts (1.9L)
<b>Engine Cooling System (including block, lines, and radiator)</b>	<ul style="list-style-type: none"><li>• <b>Final Tier 4</b> - 10 gallons (37.9L), John Deere Cool -Gard™ II</li><li>• <b>Tier 3</b> - 9.55 gallons (36.2L), John Deere Cool -Gard™ II (Export only)</li></ul>
<b>Diesel Exhaust Fluid (DEF) Tank (Tier 4 Final Engines)</b>	5 gallons (18.9L), John Deere Diesel Exhaust Fluid (DEF)
<b>Hydraulic Oil (including lines, filter, cooler, etc.)</b>	39 gallons (147.5L), John Deere Hy-Gard™
<b>Hydraulic Oil Reservoir</b>	25 gallons (94.5L)
<b>Wheel Hubs (4)</b>	27 oz. (.8 L)/each, 75W-90 gear oil
<b>Rinse Tank</b>	100 gallons (378.5L)
<b>Hand Wash Tank</b>	4 gallons (15L)
<b>Foam Marker Tank</b>	1 gallon (3.8L), foam concentrate
<b>Air Conditioning System (Charge)</b>	3.50 lbs. (1.59 kg), R-134A

^ Operators with machines equipped with All-Wheel Steer (AWS) pay special attention.

**Tire Specifications**

**NOTICE**

Do not exceed tire load limit. Failure to comply will result in weight overload and will void the warranty.

<b>TIRE SPECIFICATIONS (STANDARD)</b>										
Size	Make	Model	Load Rating (Weight/Speed)	Air Pressure (Max PSI)	Tread Width (inches)	Load Capacity (lbs.)	Overall Diameter (inches)	Static Load Radius* (inches)	Rolling Circum. (inches)	Gross Flat Plate (in <sup>2</sup> )
380/80R38	Goodyear®	Ultra Sprayer	155A8/B	64	14.6	8,550	62.4	28.2	188	217
IF320/80R42	Goodyear	Super Traction	149D	49	11.7	7,150	62.4	28.2	188	205
380/80R38	Alliance	Farm Pro	152A8/B	58	14.8	7,850	62.1	28.7	185.9	231
540/65R30	Alliance	550	161A8/156D	46	21.5	10,190	57.5	26.2	173.3	288
VF420/85R42	Michelin	Yieldbib	154A8/154B	23	17	8,270	62.3	27.5	184.3	312

<b>TIRE SPECIFICATIONS (METRIC)</b>										
Size	Make	Model	Load Rating (Weight/Speed)	Air Pressure (Max Bar)	Tread Width (cm)	Load Capacity (kg)	Overall Diameter (cm)	Static Load Radius* (cm)	Rolling Circum. (cm)	Gross Flat Plate (cm <sup>2</sup> )
380/80R38	Goodyear	Ultra Sprayer	155A8/B	4.4	37.1	3,878	158.5	71.6	477.5	1,399.9
IF320/80R42	Goodyear	Super Traction	149D	3.4	29.7	3,243	158.4	71.6	477.5	1,322
380/80R38	Alliance	Farm Pro	142A8/B	4.0	37.6	3,560	157.7	72.9	472.2	1,490
540/65R30	Alliance	550	161A8/156D	3.2	54.6	4,622	146.1	66.5	440.2	1,858
VF420/85R42	Michelin	Yieldbib	154A8/154B	1.6	43.2	3,751	158.2	69.9	468.1	2,012

\* Static load radius is suggested and will vary with load.

TIRE LOAD LIMITS (LBS) AT VARIOUS COLD INFLATION PRESSURES (PSI)											
		Inflation (psi)	6	9	12	15	17	20	23	26	29
380/80R38	Goodyear		2,270	2,760	3,200	3,640	4,180	5,440	5,080	5,360	5,520
IF320/80R42	Goodyear		N/A	N/A	3,200	3,640	4,080	4,540	4,940	5,200	5,520
380/80R38	Alliance		N/A	N/A	N/A	N/A	N/A	N/A	4,640	4,900	5,040
540/65R30	Alliance		3,350	4,050	4,660	5,410	6,070	6,770	7,460	7,665	8,120
VF420/85R42	Michelin		3,750	4,510	5,270	6,020	6,780	7,520	8,270	N/A	N/A

TIRE LOAD LIMITS (LBS) AT VARIOUS COLD INFLATION PRESSURES (PSI) (CONTINUED)											
		Inflation (psi)	35	41	46	52	58	64			
380/80R38	Goodyear		5,840	6,400	6,950	7,400	7,850	8,550			
IF320/80R42	Goodyear		5,840	6400	6950	N/A	N/A	N/A			
380/80R38	Alliance		5,340	N/A	6,350	6,750	7,150	N/A			
540/65R30	Alliance		8,610	9,350	10,190	N/A	N/A	N/A			
VF420/85R42	Michelin		N/A	N/A	N/A	N/A	N/A	N/A			

*NOTE: There are no adjustments to the loads and pressures in the above table for lower speeds or stationary service.*

*NOTE: Minimum inflation pressures for IF agricultural tires used as singles = 12 psi.*

**SECTION 1 –  
INTRODUCTION**



TIRE LOAD LIMITS (KG) AT VARIOUS COLD INFLATION PRESSURES (BAR)											
		Inflation (bar)	.4	.6	.8	1.0	1.2	1.4	1.6	1.8	2.0
380/80R38	Goodyear		1,030	1,252	1,451	1,651	1,896	2,468	2,304	2,431	2,504
IF320/80R42	Goodyear		N/A	N/A	1,451	1,651	1,850	2,059	2,240	2,358	2,503
380/80R38	Alliance		N/A	N/A	N/A	N/A	N/A	N/A	2,104	2,222	2,286
540/65R30	Alliance		1,520	1,837	2,114	2,454	2,753	3,071	3,384	3,477	3,683
VF420/85R42	Michelin		1,700	2,045	2,390	2,730	3,075	3,411	3,751	N/A	N/A

TIRE LOAD LIMITS (KG) AT VARIOUS COLD INFLATION PRESSURES (BAR) (CONTINUED)											
		Inflation (bar)	2.4	2.8	3.2	3.6	4.0	4.4			
380/80R38	Goodyear		2,649	2,903	3,152	3,357	3,561	3,878			
IF320/80R42	Goodyear		2,649	2,903	3,152	N/A	N/A	N/A			
380/80R38	Alliance		2,422	N/A	2,880	3,061	3,243	N/A			
540/65R30	Alliance		3,905	4,241	4,622	N/A	N/A	N/A			
VF420/85R42	Michelin		N/A	N/A	N/A	N/A	N/A	N/A			

*NOTE: There are no adjustments to the loads and pressures in the above table for lower speeds or stationary service.*

*NOTE: Minimum inflation pressures for IF agricultural tires used as singles = .8 bar.*

## TORQUE VALUES

### Unified Inch Bolt and Screw Torque Values



Bolt or Screw Size	SAE Grade 1				SAE Grade 2 <sup>a</sup>				SAE Grade 5, 5.1, or 5.2				SAE Grade 8 or 8.2			
	Lubricated <sup>b</sup>		Dry <sup>c</sup>		Lubricated <sup>b</sup>		Dry <sup>c</sup>		Lubricated <sup>b</sup>		Dry <sup>c</sup>		Lubricated <sup>b</sup>		Dry <sup>c</sup>	
	N-m	lb.-in.	N-m	lb.-in.	N-m	lb.-in.	N-m	lb.-in.	N-m	lb.-in.	N-m	lb.-in.	N-m	lb.-in.	N-m	lb.-in.
1/4	3.7	33	4.7	42	6	53	7.5	66	9.5	84	12	106	13.5	120	17	150
													N-m	lb.-ft.	N-m	lb.-ft.
5/16	7.7	68	9.8	86	12	106	15.5	137	19.5	172	25	221	28	20.5	35	26
									N-m	lb.-ft.	N-m	lb.-ft.				
3/8	13.5	120	17.5	155	22	194	27	240	35	26	44	32.5	49	36	63	46
			N-m	lb.-ft.	N-m	lb.-ft.	N-m	lb.-ft.								
7/16	22	194	28	20.5	35	26	44	32.5	56	41	70	52	80	59	100	74
	N-m	lb.-ft.														
1/2	34	25	42	31	53	39	67	49	85	63	110	80	120	88	155	115
9/16	48	35.5	60	45	76	56	95	70	125	92	155	115	175	130	220	165
5/8	67	49	85	63	105	77	135	100	170	125	215	160	240	175	305	225
3/4	120	88	150	110	190	140	240	175	300	220	380	280	425	315	540	400
7/8	190	140	240	175	190	140	240	175	490	360	615	455	690	510	870	640
1	285	210	360	265	285	210	360	265	730	540	920	680	1030	760	1300	960
1-1/8	400	300	510	375	400	300	510	375	910	670	1150	850	1450	1075	1850	1350
1-1/4	570	420	725	535	570	420	725	535	1280	945	1630	1200	2050	1500	2600	1920
1-3/8	750	550	950	700	750	550	950	700	1700	1250	2140	1580	2700	2000	3400	2500
1-1/2	990	730	1250	930	990	730	1250	930	2250	1650	2850	2100	3600	2650	4550	3350

Torque values listed are for general use only, based on the strength of the bolt or screw. **DO NOT** use these values if a different torque value or tightening procedure is given for a specific application. For plastic insert or crimped steel-type lock nuts, for stainless steel fasteners, or for nuts on U-bolts, see the tightening instructions for the specific application. Shear bolts are designed to fail under predetermined loads. Always replace shear bolts with identical grade.

Replace fasteners with the same or higher grade. If higher grade fasteners are used, tighten these to the strength of the original. Make sure fastener threads are clean and that you properly start thread engagement. When possible, lubricate plain or zinc plated fasteners other than lock nuts, wheel bolts or wheel nuts, unless different instructions are given for the specific application.

# SECTION 1 – INTRODUCTION



<sup>a</sup>Grade 2 applies for hex cap screws (not hex bolts) up to 6 in. (152 mm) long. Grade 1 applies for hex cap screws over 6 in. (152 mm) long, and for all other types of bolts and screws of any length.

<sup>b</sup>“Lubricated” means coated with a lubricant such as engine oil, fasteners with phosphate and oil coatings, or 7/8 in. and larger fasteners with JDM F13C, F13F or F13J zinc flake coating.

<sup>c</sup>“Dry” means plain or zinc plated without any lubrication, or 1/4 to 3/4 in. fasteners with JDM F13B, F13E or F13H zinc flake coating.

## Metric Bolt and Screw Torque Values

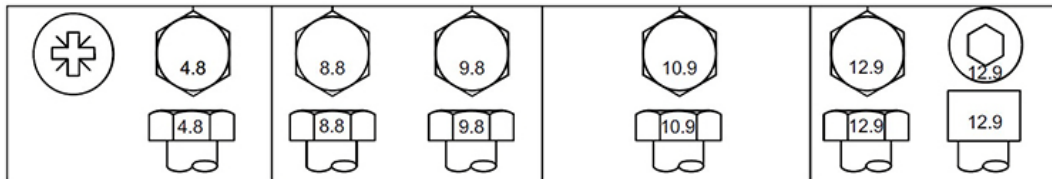

Bolt or Screw Size	Class 4.8				Class 8.8 or 9.8				Class 10.9				Class 12.9			
	Lubricated <sup>a</sup>		Dry <sup>b</sup>		Lubricated <sup>a</sup>		Dry <sup>b</sup>		Lubricated <sup>a</sup>		Dry <sup>b</sup>		Lubricated <sup>a</sup>		Dry <sup>b</sup>	
	N·m	lb.-in.	N·m	lb.-in.	N·m	lb.-in.	N·m	lb.-in.	N·m	lb.-in.	N·m	lb.-in.	N·m	lb.-in.	N·m	lb.-in.
M6	4.7	42	6	53	8.9	79	11.3	100	13	115	16.5	146	15.5	137	19.5	172
									N·m	lb.-ft.	N·m	lb.-ft.	N·m	lb.-ft.	N·m	lb.-ft.
M8	11.5	102	14.5	128	22	194	27.5	243	32	23.5	40	29.5	37	27.5	47	35
			N·m	lb.-ft.	N·m	lb.-ft.	N·m	lb.-ft.								
M10	23	204	29	21	43	32	55	40	63	46	80	59	75	55	95	70
	N·m	lb.-ft.														
M12	40	29.5	50	37	75	55	95	70	110	80	140	105	130	95	165	120
M14	63	46	80	59	120	88	150	110	175	130	220	165	205	150	260	190
M16	100	74	125	92	190	140	240	175	275	200	350	255	320	235	400	300
M18	135	100	170	125	265	195	330	245	375	275	475	350	440	325	560	410
M20	190	140	245	180	375	275	475	350	530	390	675	500	625	460	790	580
M22	265	195	330	245	510	375	650	480	725	535	920	680	850	625	1080	800
M24	330	245	425	315	650	480	820	600	920	680	1150	850	1080	800	1350	1000
M27	490	360	625	460	950	700	1200	885	1350	1000	1700	1250	1580	1160	2000	1475
M30	660	490	850	625	1290	950	1630	1200	1850	1350	2300	1700	2140	1580	2700	2000
M33	900	665	1150	850	1750	1300	2200	1625	2500	1850	3150	2325	2900	2150	3700	2730
M36	1150	850	1450	1075	2250	1650	2850	2100	3200	2350	4050	3000	3750	2770	4750	3500

Torque values listed are for general use only, based on the strength of the bolt or screw. DO NOT use these values if a different torque value or tightening procedure is given for a specific application. For stainless steel fasteners or for nuts on U-bolts, see the tightening instructions for

the specific application. Tighten plastic insert of crimped steel-type lock nuts by turning the nut to the dry torque shown in the chart, unless different instructions are given for the specific application.

Shear bolts are designed to fail under predetermined loads. Always replace shear bolts with identical property class. Replace fasteners with the same or higher property class. If higher property class fasteners are used, tighten these to the strength of the original. Make sure fastener threads are clean and that you properly start thread engagement. When possible, lubricate plain or zinc plated fasteners other than lock nuts, wheel bolts or wheel nuts, unless different instructions are given for the specific application.

<sup>a</sup>“Lubricated” means coated with a lubricant such as engine oil, fasteners with phosphate and oil coatings, or M20 and larger fasteners with JDM F13C, F13F or F13J zinc flake coating.

<sup>b</sup>“Dry” means plain or zinc plated without any lubrication, or M6 to M18 fasteners with JDM F13B, F13E or F13H zinc flake coating.

## **Face Seal Fittings Assembly and Installation - All Pressure Applications**

### **Face Seal O-Ring to Stud End Installation**

1. Inspect the fitting surfaces. They must be free of dirt and/or defects.
2. Inspect the O-ring. It must be free of damage and/or defects.
3. Lubricate O-rings using system oil, and install into groove.
4. Push O-ring into groove so O-ring is not displaced during assembly.
5. Index angle fittings and tighten by hand pressing joint together to insure O-ring remains in place.
6. Tighten fitting or nut to torque value shown on the chart per dash size stamped on the fitting. DO NOT allow hoses to twist when tightening fittings.

### **Face Seal Adjustable Stud End O-Ring Installation**

1. Back off lock nut (jam nut) and washer to full exposed turned down section of the fitting.
2. Install a thimble over the fitting threads to protect the O-ring from nicks.
3. Slide the O-ring over the thimble into the turned down section of the fitting.
4. Remove thimble.

### **Face Seal Straight Stud End O-Ring Installation**

1. Install a thimble over the fitting threads to protect the O-ring from nicks.
2. Slide the O-ring over the thimble into the turned down section of the fitting.
3. Remove thimble.

### **Fitting Installation**

1. Install fitting by hand until snug.
2. Position adjustable fittings by unscrewing the fitting no more than one turn.
3. Apply assembly torque per table.

### **Assembly Torque**

1. Use one wrench to hold the connector body and one wrench to tighten nut.
2. For a hydraulic hose, it may be necessary to use three wrenches to prevent twist; one on the connector body, one on the nut, and one on the body of the hose fitting.

# SECTION 1 – INTRODUCTION



## Metric Face Seal and O-Ring Stud End Fitting Torque Values

### Standard Pressure Applications

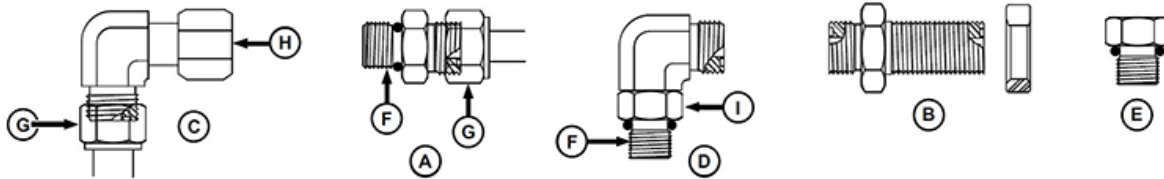

- A - Stud Straight and Tube Nut
- B - Bulkhead Union and Bulkhead Lock Nut
- C - 90° Swivel Elbow and Tube Nut
- D - 90° Adjustable Stud Elbow
- E - Port Plug
- F - Stud End
- G - Tube Nut
- H - Swivel Nut
- I - Lock Nut

**Metric Face Seal and O-Ring Stud End Fitting Torque Chart - Standard Pressure (Below 27.6 MPA/4,000 PSI)**

Nominal Tube OD Hose ID		O-Ring Face Seal/ Tube Swivel Nut						Bulkhead Jam Nut Torque <sup>A</sup>			O-Ring Straight, Adjustable, and External Port Plug Stud Ends <sup>A</sup>						
Metric Tube OD	Inch Tube OD			Thread Size	Swivel Nut Hex Size	Tube Nut/ Swivel Nut Torque		Jam Nut Hex Size	Jam Nut Torque		Thread Size	Straight Hex Size <sup>B</sup>	Adj Lock Nut Hex Size	Steel or Gray Iron Torque		Aluminum or Brass Torque <sup>C</sup>	
mm	Dash Size	in.	mm	in.	mm	N·m	lb.-ft.	mm	N·m	lb.-ft.	mm	mm	mm	N·m	lb.-ft.		
N·m	lb.-ft.																
4	-2	0.1 -25	3.18	---	---	---	---	---	---	---	M8x1	12	12	8	6	5	4
5	-3	0.1 -88	4.76	---	---	---	---	---	---	---	M10x1	14	14	15	11	10	7
6	-4	0.2 -50	6.35	9/16- 18	17	24	18	22	32	24	M12x1.5	17	17	25	18	17	12
8	-5	0.3 -12	7.92	---	---	---	---	---	---	---	M14x1.5	19	19	40	30	27	20
10	-6	0.3 -75	9.53	11/16- 16	22	37	27	27	42	31	M16x1.5	22	22	45	33	30	22
12	-8	0.5 -00	12.7- 0	13/16- 16	24	50	37	30	93	69	M18x1.5	24	24	50	37	33	25



16	-10	0.6 -25	15.8- 8	1-14	30	69	51	36	118	87	M22x1.5	27	27	69	51	46	34
20	-12	0.7 -50	19.0- 5	1-3/16- 12	36	102	75	41	175	129	M27x2	32	32	10- 0	74	67	49
22	-14	0.8 -75	22.2- 3	1-3/16- 12	36	102	75	41	175	129	M30x2	36	36	13- 0	96	87	64
25	-16	1.0 -00	25.4- 0	1-7/16- 12	41	142	105	46	247	182	M33x2	41	41	16- 0	118	1- 07	79
28	---	---	---	---	---	---	---	---	---	---	M38x2	46	46	17- 6	130	1- 17	87
32	-20	1.2 -50	31.7- 5	1-11/ 16-12	50	190	140	50	328	242	M42x2	50	50	21- 0	155	1- 40	1- 03
38	-24	1.5 -00	38.1- 0	2-12	60	217	160	60	374	276	M48x2	55	55	26- 0	192	1- 73	1- 28
50	-32	2.0 -00	50.8- 0	---	---	---	---	---	---	---	M60x2	65	65	31- 5	232	2- 10	1- 55

*A* Tolerance is +15%, minus 20% of mean tightening torque unless otherwise specified.

*B* The straight hex wrench sizes listed apply to connectors only and may not be the same as the corresponding plug of the same thread size.

*C* These torques were established using steel plated connectors in aluminum and brass.

## Metric Face Seal and O-Ring Stud End Fitting Torque Values

### High Pressure Applications

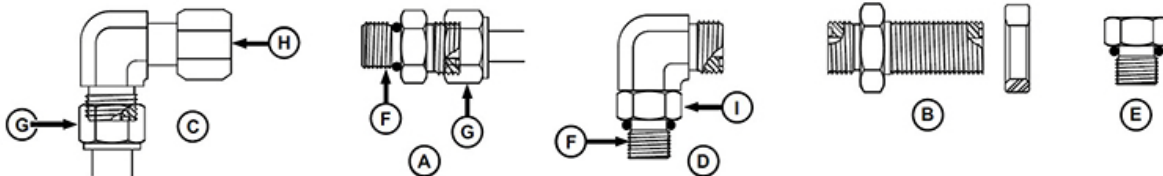

- A - Stud Straight and Tube Nut
- B - Bulkhead Union and Bulkhead Lock Nut
- C - 90° Swivel Elbow and Tube Nut
- D - 90° Adjustable Stud Elbow
- E - Port Plug

- F - Stud End
- G - Tube Nut
- H - Swivel Nut
- I - Lock Nut

# SECTION 1 – INTRODUCTION



Metric Face Seal and O-Ring Stud End Fitting Torque Chart High Pressure (Above 27.6 MPA/4,000 PSI), Working Pressure (41.3 MPA/6,000 PSI)															
Nominal Tube OD Hose ID				O-Ring Face Seal/ Tube Swivel Nut				Bulkhead Jam Nut Torque <sup>A</sup>			O-Ring Straight, Adjustable, and External Port Plug Stud Ends <sup>A</sup>				
Metric Tube OD	Inch Tube OD			Thread Size	Swivel Nut Hex Size	Tube Nut/ Swivel Nut Torque		Jam Nut Hex Size	Jam Nut Torque		Thread Size	Straight Hex Size <sup>B</sup>	Adj Lock Nut Hex Size	Steel or Gray Iron Torque	
	mm	Dash Size	in.			mm	in.		mm	N-m				lb.-ft.	mm
4	-2	0.12-5	3.18	---	---	---	---	---	---	---	M8x1	12	12	8	6
5	-3	0.18-8	4.76	---	---	---	---	---	---	---	M10x1	14	14	15	11
6	-4	0.25-0	6.35	9/16-18	17	24	18	22	32	24	M12x1.5	17	17	35	26
8	-5	0.31-2	7.92	---	---	---	---	---	---	---	M14x1.5	19	19	45	33
10	-6	0.37-5	9.53	11/16-16	22	37	27	27	42	31	M16x1.5	22	22	55	41
12	-8	0.50-0	12.70	13/16-16	24	63	46	30	93	69	M18x1.5	24	24	70	52
16	-10	0.62-5	15.88	1-14	30	103	76	36	118	87	M22x1.5	27	27	100	74
20	-12	0.75-0	19.05	1-3/16-12	36	152	112	41	175	129	M27x2	32	32	170	125
22	-14	0.87-5	22.23	1-3/16-12	36	152	112	41	175	129	M30x2	36	36	215	159
25	-16	1.00-0	25.40	1-7/16-12	41	214	158	46	247	182	M33x2	41	41	260	192
28	---	---	---	---	---	---	---	---	---	---	M38x2	46	46	320	236
32	-20	1.25-0	31.75	1-11/16-12	50	286	211	50	328	242	M42x2	50	50	360	266
38	-24	1.50-0	38.10	2-12	60	326	240	60	374	276	M48x2	55	55	420	310

<sup>A</sup>Tolerance is +15%, minus 20% of mean tightening torque unless otherwise specified.

<sup>B</sup>The straight hex wrench sizes listed apply to connectors only and may not be the same as the corresponding plug of the same thread size.

## SAE Face Seal and O-Ring Stud End Fitting Torque Values

### Standard Pressure Applications

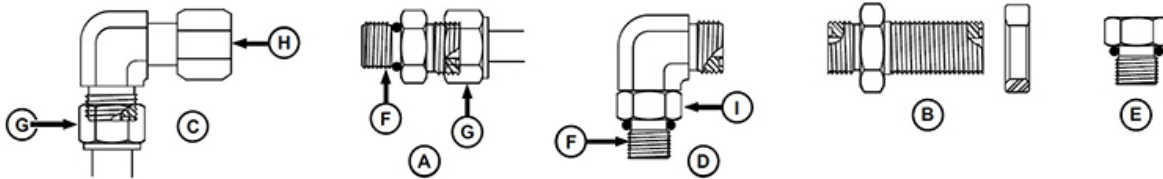

- A - Stud Straight and Tube Nut
- B - Bulkhead Union and Bulkhead Lock Nut
- C - 90° Swivel Elbow and Tube Nut
- D - 90° Adjustable Stud Elbow
- E - Port Plug
- F - Stud End
- G - Tube Nut
- H - Swivel Nut
- I - Lock Nut

**SAE Face Seal and O-Ring Stud End Fitting Torque Chart - Standard Pressure (Below 27.6 MPA/4,000 PSI)**

Nominal Tube OD Hose ID				O-Ring Face Seal/ Tube Swivel Nut				Bulkhead Jam Nut Torque <sup>A</sup>				O-Ring Straight, Adjustable, and External Port Plug Stud Ends <sup>A</sup>					
												Thread Size	Swivel Nut Hex Size	Tube Nut/ Swivel Nut Torque	Jam Nut Hex Size	Jam Nut Torque	Thread Size
Metric Tube OD	Inch Tube OD			in.	in.	N-m	lb.-ft.	in.	in.	N-m	lb.-ft.	in.	in.	in.	in.		
mm	Dash Size	in.	mm	in.	in.	N-m	lb.-ft.	in.	in.	N-m	lb.-ft.	in.	in.	in.	in.		
N-m	lb.-ft.	N-m	lb.-ft.														
5	-3	0.188	4.78	---	---	---	---	---	---	---	3/8-24	5/8	9/16	12	9	8	6
6	-4	0.250	6.35	9/16-18	11/16	24	18	13/16	32	24	7/16-20	5/8	5/8	16	1-2	11	8
8	-5	0.312	7.92	---	---	---	---	---	---	---	1/2-20	3/4	11/16	24	1-8	16	1-2
10	-6	0.375	9.53	11/16-16	13/16	37	27	1	42	31	9/16-18	3/4	3/4	37	2-7	25	1-8
12	-8	0.500	12.70	13/16-16	15/16	50	37	1-1/8	93	69	3/4-16	7/8	15/16	50	3-7	33	2-5
16	-10	0.625	15.88	1-14	1-1/8	69	51	1-5/16	1-18	87	7/8-14	1-1/16	1-1/16	69	5-1	46	3-4
20	-12	0.750	19.05	1-3/16-12	1-3/8	1-02	75	1-1/2	1-75	1-29	1-1/16-12	1-1/4	1-3/8	10-2	7-5	68	5-0
22	-14	0.875	22.23	1-3/16-12	---	1-02	75	---	1-75	1-29	1-3/16-12	1-3/8	1-1/2	12-2	9-0	81	6-0
25	-16	1.000	25.40	1-7/16-12	1-5/8	1-42	10-5	1-3/4	2-47	1-82	1-5/16-12	1-1/2	1-5/8	14-2	1-0-5	95	7-0
32	-20	1.25	31.75	1-11/16-12	1-7/8	1-90	14-0	2	3-28	2-42	1-5/8-12	1-3/4	1-7/8	19-0	1-4-0	1-27	9-3
38	-24	1.50	38.10	2-12	2-1/4	2-17	16-0	2-3/8	3-74	2-76	1-7/8-12	2-1/8	2-1/8	21-7	1-6-0	1-45	1-0-7
50.8	-32	2.000	50.80	---	---	---	---	---	---	---	2-1/2-12	2-3/4	2-3/4	31-1	2-2-9	2-07	1-5-3

<sup>A</sup>Tolerance is +15%, minus 20% of mean tightening torque unless otherwise specified.

# SECTION 1 – INTRODUCTION



<sup>B</sup>The straight hex wrench sizes listed apply to connectors only and may not be the same as the corresponding plug of the same thread size.

<sup>C</sup>These torques were established using steel plated connectors in aluminum and brass.

## SAE Face Seal and O-Ring Stud End Fitting Torque Values

### High Pressure Applications

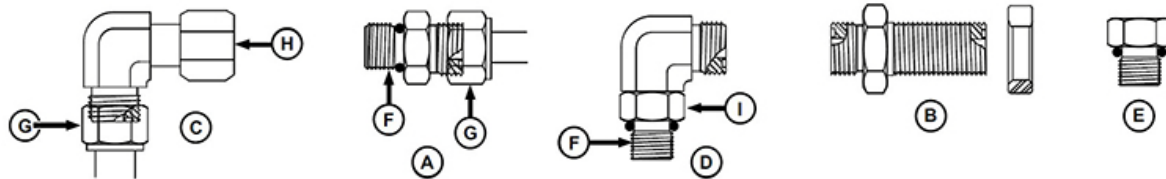

- A - Stud Straight and Tube Nut
- B - Bulkhead Union and Bulkhead Lock Nut
- C - 90° Swivel Elbow and Tube Nut
- D - 90° Adjustable Stud Elbow
- E - Port Plug
- F - Stud End
- G - Tube Nut
- H - Swivel Nut
- I - Lock Nut

SAE Face Seal and O-Ring Stud End Fitting Torque Chart High Pressure (Above 27.6 MPA/4,000 PSI), Working Pressure (41.3 MPA/6,000 PSI)															
Nominal Tube OD Hose ID				O-Ring Face Seal/ Tube Swivel Nut				Bulkhead Jam Nut Torque <sup>A</sup>				O-Ring Straight, Adjustable, and External Port Plug Stud Ends <sup>A</sup>			
Metric Tube OD	Inch Tube OD			Thread Size	Swivel Nut Hex Size	Tube Nut/ Swivel Nut Torque		Jam Nut Hex Size	Jam Nut Torque		Thread Size	Straight Hex Size <sup>B</sup>	Adj Lock Nut Hex Size	Steel or Gray Iron Torque	
	mm	Dash Size	in.			mm	in.		N-m	lb.-ft.				N-m	lb.-ft.
5	-3	0.18-8	4.78	---	---	---	---	---	---	---	3/8-24	5/8	9/16	18	13
6	-4	0.25-0	6.35	9/16-18	11/16	24	18	13/16	32	24	7/16-20	5/8	5/8	24	18
8	-5	0.31-2	7.92	---	---	---	---	---	---	---	1/2-20	3/4	11/16	30	22
10	-6	0.37-5	9.53	11/16-16	13/16	37	27	1	42	31	9/16-18	3/4	3/4	37	27
12	-8	0.50-0	12.70	13/16-16	15/16	63	46	1-1/8	93	69	3/4-16	7/8	15/16	75	55
16	-10	0.62-5	15.88	1-14	1-1/8	103	76	1-5/16	118	87	7/8-14	1-1/16	1-1/16	103	76
20	-12	0.75-0	19.05	1-3/16-12	1-3/8	152	112	1-1/2	175	129	1-1/16-12	1-1/4	1-3/8	177	131
22	-14	0.87-5	22.23	1-3/16-12	---	152	112	---	175	129	1-3/16-12	1-3/8	1-1/2	231	170
25	-16	1.00-0	25.40	1-7/16-12	1-5/8	214	158	1-3/4	247	182	1-5/16-12	1-1/2	1-5/8	270	199
32	-20	1.25	31.75	1-11/16-12	1-7/8	286	211	2	328	242	1-5/8-12	1-3/4	1-7/8	286	211
38	-24	1.50	38.10	2-12	2-1/4	326	240	2-3/8	374	276	1-7/8-12	2-1/8	2-1/8	326	240

<sup>A</sup>Tolerance is +15%, minus 20% of mean tightening torque unless otherwise specified.

<sup>B</sup>The straight hex wrench sizes listed apply to connectors only and may not be the same as the corresponding plug of the same thread size.

**Four Bolt Flange Fittings  
Assembly and Installation - All  
Pressure Applications**

1. Inspect the sealing surfaces for nicks or scratches, roughness or out-of-flat condition. Scratches cause leaks. Roughness causes seal wear. Out-of-flat causes seal extrusion. If these defects cannot be polished out, replace the component.
2. Install the correct O-ring (and backup washer if required) into the groove using petroleum jelly to hold it in place.
3. For split flange; loosely assemble split flange halves, being sure that the split is centrally located and perpendicular to the port. Hand-tighten cap screws to hold parts in place. Do not pinch O-ring.
4. For single piece flange; put hydraulic line in the center of the flange and install four cap screws. With the flange centrally located on the port, hand-tighten cap screws to hold it in place. Do not pinch O-ring.
5. For both single piece flange and split flange, be sure the components are properly positioned and cap screws are hand tight. Tighten one cap screw, then tighten the diagonally opposite cap screw. Tighten the two remaining cap screws. Tighten all cap screws within the specified limits shown in the chart. **DO NOT** use air wrenches. **DO NOT** tighten one cap screw fully before tightening the others. **DO NOT** over-tighten.

**SAE Four Bolt Flange Cap Screw Torque Values**

**Standard Pressure Applications**

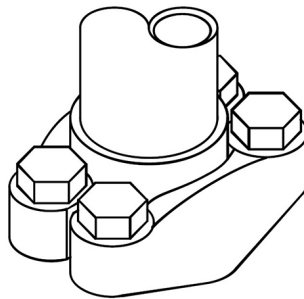

SAE Four Bolt Flange Cap Screw Torque Values - 27,600 KPA (4,000 PSI) Pressure Applications					
		Torque			
		Newton Meters		Foot Pounds	
Nominal Flange Size	Screw Size <sup>ab</sup>	Min	Max	Min	Max
1/2	5/16-18 UNC	20	31	15	23
3/4	3/8-16 UNC	28	54	21	40
1	3/8-16 UNC	37	54	27	40

## SECTION 1 – INTRODUCTION



1-1/4	7/16-14 UNC	47	85	35	63
1-1/2	1/2-13 UNC	62	131	46	97
2	1/2-13 UNC	73	131	54	97
2-1/2	1/2-13 UNC	107	131	79	97
3	5/8-11 UNC	187	264	138	195
3-1/2	5/8-11 UNC	158	264	117	195
4	5/8-11 UNC	158	264	117	195
5	5/8-11 UNC	158	264	117	195

<sup>a</sup>JDM A17D, SAE Grade 5 or better cap screws with plated hardware.

<sup>b</sup>1.5.1.2 Lock washers are permissible but not recommended.

## SAE Four Bolt Flange Cap Screw Torque Values

### High Pressure Applications

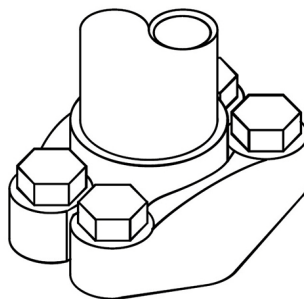

SAE Four Bolt Flange Cap Screw Torque Values - 41,400 KPA (6,000 PSI) Pressure Applications					
		Torque			
		Newton Meters		Foot Pounds	
Nominal Flange Size	Screw Size <sup>ab</sup>	Min	Max	Min	Max
1/2	5/16-18 UNC	20	31	15	23
3/4	3/8-16 UNC	34	54	25	40
1	7/16-14 UNC	57	85	42	63
1-1/4	1/2-13 UNC	85	131	63	63
1-1/2	5/8-11 UNC	159	264	117	195
2	3/4-10 UNC	271	468	200	345

<sup>a</sup>JDM A17D, SAE Grade 5 or better cap screws with plated hardware.

<sup>b</sup>1.5.1.2 Lock washers are permissible but not recommended.

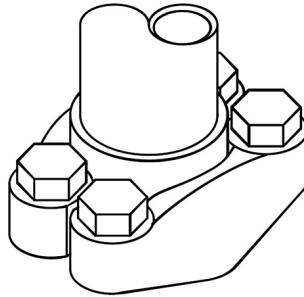
**External Hexagon Port Plug Torque Values**

Port or Stud End Thread Size <sup>a</sup>	Torque (+15%/-20%)
M8 x 1	10 N·m (89 lb.-in.)
M10 x 1	17 N·m (150 lb.-in.)
M12 x 1.5	28 N·m (20.6 lb.-in.)
M14 x 1.5	39 N·m (28.7 lb.-in.)
M16 x 1.5	48 N·m (35.4 lb.-in.)
M18 x 1.5	60 N·m (44.2 lb.-in.)
M20 x 1.5	60 N·m (44.2 lb.-in.)
M22 x 1.5	85 N·m (62.7 lb.-in.)
M27 x 2	135 N·m (99.6 lb.-in.)
M30 x 2	165 N·m (121.7 lb.-in.)
M33 x 2	235 N·m (173.3 lb.-in.)
M38 x 2	245 N·m (180.7 lb.-in.)
M42 x 2	260 N·m (191.8 lb.-in.)
M48 x 2	290 N·m (213.9 lb.-in.)
M60 x 2	330 N·m (243.4 lb.-in.)

<sup>a</sup>Port to JDS-G173.1; stud end to JDS-G173.3.



## SECTION 2 – SAFETY AND PRECAUTIONS

### INTENDED USE

#### NOTICE

This machine is designed for and intended to be used for the application of chemicals and fertilizers to field crops. Use in any other way or for any other purpose is considered misuse of this machine.

Most accidents occur as the result of failure to follow basic and fundamental safety rules and precautions. Recognizing potential safety hazards, following correct and safe operating procedures described in this manual, and complying with safety warnings located throughout the machine may reduce the risk of accidents.

There is no way to completely eliminate the potential for danger when operating agricultural equipment. Therefore, you must study this operator's manual and understand how to operate the sprayer controls for safe operation before using the sprayer, its attachment, or any sprayer equipment. Likewise, never let anyone operate the machine without proper instruction.

Do not operate the sprayer, its attachment, or any sprayer equipment for anything other than their intended uses. Hagie Manufacturing Company shall not be liable for any damage, injury, or death associated with improper use of the sprayer, its attachment, or any sprayer equipment.

Do not make any modifications such as, but not limited to, weldments, add-ons, adaptations, or changes from the original design of the sprayer. Such modifications may become safety hazards to you and others and **will void all warranties**.

Replace missing, faded, or damaged safety signs. Refer to "Safety Decals" elsewhere in this section for correct sign and placement.

### SAFETY PRECAUTIONS

*NOTE: If your machine is equipped with All Wheel Steer (AWS), pay special attention to components, operating instructions, and safety precautions marked with ^.*

#### Do Not Bypass Safety Start

- Start the machine from the operator's seat only.
- The machine must be in NEUTRAL and the parking brake must be engaged before starting the engine.



#### Use Caution While Driving ^

- Never drive near ditches, embankments, holes, mounds, or other obstacles.
- Never drive on hills too steep for safe operation.

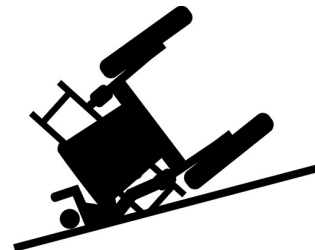

- Reduce machine speed before turning.





- Do not permit passengers to ride on the machine while it is moving. Failure to comply may result in passenger falling off of machine and/or obstructing the operator's view.
- Keep riders off machine. The only time a passenger should be permitted to ride inside the cab is for instructional or diagnostic purposes only. The passenger should be seated in the instructor seat next to the operator with seat belt fastened and never allowed to ride outside of the cab.



- Ensure there is adequate clearance before driving under any overhead obstructions. Contact with power lines may result in serious injury or death.
- Booms must be folded and in cradles when driving the machine on a roadway or when near power lines.



### Remove Paint Before Welding or Heating

- Avoid toxic fumes and dust. Hazardous fumes can be generated when paint is heated by welding, soldering, or using a torch.



- Do not use chlorinated solvents in areas where welding will take place.
- Perform all work in an area that is well ventilated to carry toxic fumes and dust away.
- Dispose of paint and solvents properly.

### Avoid Heating Near Pressurized Lines

- Avoid torching, welding, and soldering near pressurized hydraulic lines. Pressurized lines may accidentally burst when heat goes beyond the immediate flame area.



### Handle Fuel Safely

- Always turn the engine off and allow it to cool before refueling.
- NEVER smoke while refueling.



- Do not fill tank completely, as fuel may expand and run over.
- Always clean up spilled fuel with soapy water.
- Keep a fire extinguisher nearby when refueling.

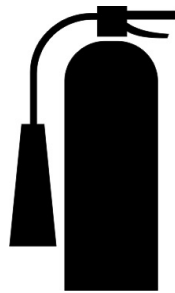

### Operate Safely ^

- Before moving the machine, ensure there are no obstacles or persons in the path of travel.
- Never operate a machine in the same field as walking personnel.
- Always drive at a reasonable field speed.
- Never operate the machine on a roadway with solution in the tanks. Additional weight caused from a full or partially full solution tanks may cause erratic or increased stopping distance.
- Do not operate the machine at speeds exceeding 20 mph (32 km/h) with solution in the tanks. Operating speeds exceeding 20 mph (32 km/h) with fully loaded tanks may result in tire blow-out or wheel hub damage and will void the warranty.

- Ensure the Slow Moving Vehicle (SMV) emblem and the Speed Indicator Symbol (SIS) are in place and visible from the rear of machine when traveling on public roadways.



SMV



SIS (mph)



SIS (km/h)

- Pull over to the side of the road before stopping.
- Always come to a complete stop before reversing directions.
- Ensure the back-up alarm is audible when operating the machine in reverse.
- Keep a fire extinguisher nearby at all times.
- Keep ALL shields in place.
- Keep clear of all moving parts and keep others away while operating (including the reversible fan).
- Do not activate the parking brake while the machine is in motion.
- Bring machine to a gradual stop to avoid sudden downward decent.
- Reduce speed for icy, wet, graveled, or soft roadway surfaces.
- Use flashers/hazard warning lights (day or night) unless prohibited by law.
- Keep away from overhead power lines. Serious injury or death may result to you or others should the machine come into contact with electrical power lines.
- Never use starting fluid to assist engine start-up.
- If your machine is equipped with ground speed sensing radar or light sensing depth units, do NOT look directly into radar beam, as it emits a very low intensity microwave signal, which may result in possible eye damage.

## Be Prepared

- Be prepared for an emergency. Keep a fire extinguisher, first aid kit, and clean water in the cab at all times.
- Service the fire extinguisher regularly.
- Keep an accurate inventory of supplies in the first aid kit and dispose of any item(s) that have expired.

## Wear Protective Clothing

- Do not wear loose fitting clothing that could get caught in moving parts. Wear safety equipment that is appropriate for the job.



- Do not store chemical-soaked clothing in the cab. Clean off as much mud and dirt from your shoes as you can before entering the cab.

## Protect Against Noise

- Wear suitable hearing protection. Prolonged exposure to loud noise may result in loss of hearing.



## Battery Acid Accident Prevention

**WARNING: Battery posts, terminals, and related accessories contain lead and lead compounds, chemicals known to the State of California to cause cancer and reproductive harm. Wash hands after handling.**

Avoid serious injury by avoiding battery acid contact with your body. Battery electrolyte contains sulfuric acid that is strong enough to eat holes in clothing and cause blindness if splashed into eyes.

### Make sure to:

- Fill batteries in a well ventilated area.
- Wear Personal Protective Equipment (PPE) when servicing a battery.
- Avoid inhaling of fumes when recharging with electrolyte.
- Avoid spilling or dripping electrolyte.
- When charging a battery, connect positive cable to positive terminal and negative cable to negative terminal. Failure to comply may result in an explosion and/or personal injury.

### If you spill on yourself:

- Flush affected area with cold water and remove contaminated clothing immediately. Continue to flush the area for a minimum of 15 minutes.



- Call a physician.
- While transporting or waiting for medical attention, apply compresses of iced water or immerse affected area in iced water. **DO NOT ALLOW SKIN TISSUE TO FREEZE.**
- Do not apply creams or ointments until you have been seen by a physician.

### If acid is swallowed:

- Do NOT induce vomiting.
- Drink large amounts of water.
- Seek medical attention immediately!

## SECTION 2 – SAFETY AND PRECAUTIONS



- Do not neutralize the acid.

### If fumes are inhaled:

- Move the person into fresh air.
- Do not give artificial respiration to a person that is able to breathe on their own.
- Give CPR only if there is no breathing and no pulse.
- Seek medical attention immediately!

### Handle Agricultural Chemicals Safely

Agricultural chemicals used in applications can be harmful to your health and the environment if not used properly.

- Always follow the manufacturer's label for directions of use.
- Never allow chemicals to come in contact with your skin or eyes. Always use the proper Personal Protective Equipment (PPE).
- Never pour chemicals into an empty solution tank. Always fill tank half full of water first.
- Dispose of empty chemical containers properly.



- Wash spilled chemicals or spray residue from the sprayer to prevent corrosion and deterioration.
- Select safe areas to fill, flush, calibrate, and clean the sprayer where chemicals will not run off to contaminate people, animals, vegetation, or water supply.
- Never place a spray tip/nozzle to your mouth in an attempt to unplug it.
- Do not spray when wind is in excess of chemical manufacturer's recommendation.
- Store chemicals in their original containers with the label intact.
- Store chemicals in a separate, locked building.
- Wear Personal Protective Equipment (PPE) as recommended by the chemical manufacturer.

### Safe Hydraulic Maintenance

- Always practice personal safety when performing service or maintenance on the hydraulic system.
- Use caution when working around hydraulic fluid under pressure. Escaping fluid can have sufficient force to penetrate your skin, possibly resulting in serious injury. This fluid may also be hot enough to burn.

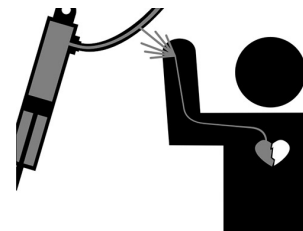

- Always lower the load or relieve the pressure before repairing a hydraulic oil leak.

### Beware of Exhaust Fumes

- Never run the machine in an enclosed area. Proper ventilation is required. Use an exhaust pipe extension to remove

fumes if you must operate inside a building. Also, open doors and windows to bring in enough outside air into the area.

### General Maintenance Safety

- Turn off engine before checking, adjusting, repairing, lubricating, or cleaning any part of the sprayer.
- Remove all chemical residue from the work area before performing service/maintenance.
- When servicing the radiator, allow engine to cool before removing the pressurized cap.



- Disconnect battery ground cable and turn the Battery Disconnect Switch OFF before servicing the electrical system or welding on the machine.



- Machines equipped with All Wheel Steer (AWS) have position sensing internal to the steering cylinders. Disconnect each sensor before welding on the machine. ^

### Remove Accumulated Crop Debris

- The buildup of crop debris in the engine compartment, on the engine, or near moving parts is a fire hazard. Check and clean areas frequently. Before performing any inspection or service, engage the parking brake, shut off the engine, and remove the key.



### Spray Booms

- Select a safe area before unfolding/folding the booms.
- Clear area of personnel.
- Cradle booms when leaving the sprayer unattended.
- Ensure booms are folded when cradled.
- Do not unfold boom extension when main boom is in the cradle.
- Do not operate the sprayer with one boom wing out of cradle and other boom wing in cradle.
- Check for overhead obstructions.
- Do not unfold or fold booms near power lines. **Contact with power lines can result in serious injury or death.** A warning message will appear on the Machine Display before extending the outer boom extensions or when operating in Auto Fold. Press ACKNOWLEDGE showing that you have acknowledged that there are no overhead power lines or obstructions before proceeding.

### Tread Adjust

- Transport machine at narrowest tread adjust setting only.

## SECTION 2 – SAFETY AND PRECAUTIONS



### All Wheel Steer (AWS) Safety ^

#### –If Equipped

Many of the following precautions are repetitious to the precautions for a standard machine. It is imperative they receive special consideration. Failure to comply with the AWS safety precautions and operating instructions may result in property damage, serious injury, or death.

- Become familiar with and understand how to operate your machine in conventional steering mode before operating with AWS.
- Understand AWS system components, operating procedures, and system limitations before operating.
- Reduce machine speed before turning.
- Never drive on hills too steep for safe operation.
- Never drive near ditches, embankments, holes, mounds, or other obstacles.
- Come to a complete stop before reversing directions.
- Always drive at a reasonable field speed.

## SEAT BELT

For your safety, wear seat belt at all times when operating the machine.

### Seat Belt Operation

- Grasp the Seat Belt Buckle (located on the outward side of seat) and extend all the way across your hips, seated below your abdomen.
- Insert the buckle tongue into the receptacle assembly (located on the opposite side of seat) and engage into LOCKED position.
- **To release Seat Belt**, press the Release Button (located on the receptacle end) and allow belt to retract.

### Inspection/Replacement

Inspect seat belt and mounting hardware yearly. Replace seat belt if anchorage system, buckle, belt, or retractor shows signs of damage, including evidence of cuts,

fraying or wear, discoloration, or being heavily soiled - especially with oil grease or fuel. Replace only with replacement parts approved for your machine.

## ROTATING BEACON

The Rotating Beacon (located on the front roof cap) is used for increased visibility to others. The beacon will illuminate when the Hazard/Warning Lights Switch (located on the steering column) is activated.

*NOTE: The Rotating Beacon is active in both Road and Field mode. The Hazard/Warning Lights are active in Road mode only.*



Rotating Beacon  
(Located on front roof cap)  
-Typical View

## EMERGENCY STOP

(E-Stop)

### NOTICE

Do not use the E-Stop Switch for non-emergency stopping or as a parking brake.

The E-Stop Switch (located on the side console) provides a quick and positive method for stopping the engine in an emergency situation.

When the E-Stop Switch is depressed, it locks in position and removes the ignition signal to shut down the engine. To reset the E-Stop Switch, turn the switch in the direction of the arrows (located on the face of the button).



E-Stop Switch  
(Located on the side console)  
-Typical View

When the E-Stop Switch is activated, a warning message will appear on the Machine Display to alert the operator that the E-Stop is engaged. Press OK to acknowledge.

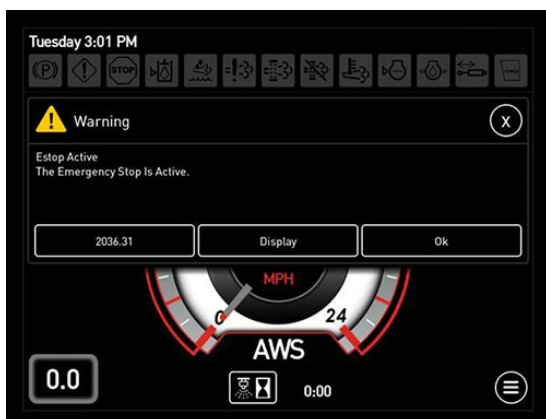

E-Stop Active Warning Message  
(Located on the Machine Display)

## EMERGENCY EXIT

### CAUTION

Do not look directly at the glass when using the Emergency Exit Tool. Failure to comply may result in personal injury.

### NOTICE

The Emergency Exit Tool is a permanent fixture of the machine. Do not remove from cab under any circumstances.

In the event of an emergency, use the cab door to exit the machine. Should the cab door become inoperable, an Emergency Exit Tool (located along the rear right-hand side of cab) is provided and is used in the rare event to shatter the glass of the cab.

- Using the metal end of the Emergency Exit Tool, repeatedly strike the glass to shatter.



Emergency Exit Tool  
(Located along rear right-hand side of cab)  
-Typical View

Should the need arise to escape from a seat belt that may become inoperable, use the “hook end” of the Emergency Exit Tool to cut the seat belt.

## **FIRE EXTINGUISHER**

Your machine is equipped with a Fire Extinguisher (located behind the left-hand side of cab). In the event that use of the Fire Extinguisher is required, follow the manufacturer’s operating instructions provided on the Fire Extinguisher.

### **To Remove Fire Extinguisher**

- Pull the Security Latch **OUTWARD** to disengage and remove Fire Extinguisher.



Fire Extinguisher  
(Located behind left-hand side of cab)  
-Typical View

### **Inspection and Replacement**

Follow the manufacturer’s recommendations on inspection and replacement.

## **SAFETY DECALS**

Decals warning you of avoidable danger are located on various parts of the machine and attachment. They are there for your personal safety and protection. **DO NOT** remove them. They will fracture upon attempted removal and therefore, must be replaced.

Following are locations of important safety decals. Replace them if they are damaged or missing. All safety decals, instructional decals, or machine striping may be purchased through your local John Deere dealer.

To replace safety decals, ensure the installation area is clean and dry and decide on exact position before you remove the backing paper.



**Safety Decal Locations**

**650114**

(Located on rinse tank)

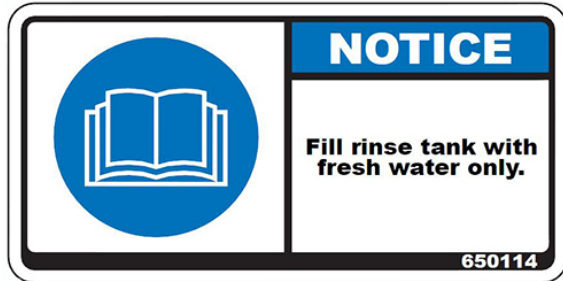

**N408864**

(Located near hand wash tank)



**N403721**

(Located on inner right-hand side of ladder)



**650584**

(Located near radiator)

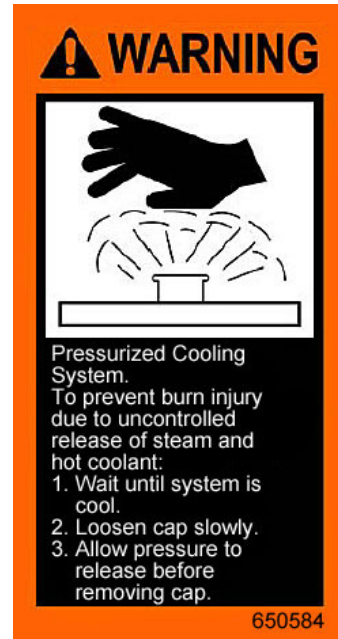

**N303688**

(Located on rear right-hand cab post)



## SECTION 2 – SAFETY AND PRECAUTIONS



L212136

(4) - Located near each lifting point  
containment ring

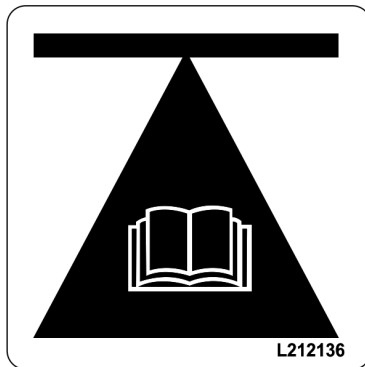

RISK OF INJURY DUE TO IMPROPER LIFTING.  
DO NOT ATTEMPT TO LIFT MACHINE  
WITHOUT JACKS PROPERLY SEATED IN THE  
LIFTING POINT CONTAINMENT RINGS.

650518

(Located near battery disconnect  
switch)

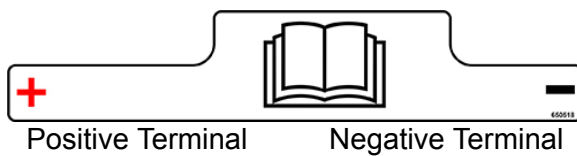

650493

(Located near hydraulic oil reservoir  
sight gauge)

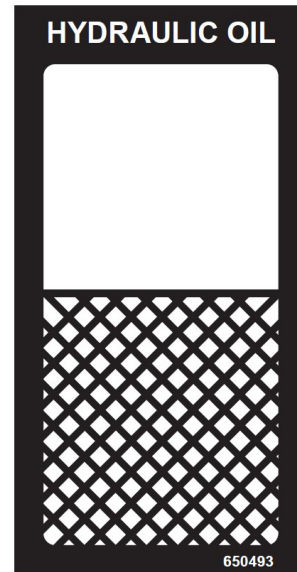

HYDRAULIC OIL RESERVOIR LEVEL

650637

(Located on front bulk head beneath  
left-hand side of cab)



**N404969**

- (1) - Located on main air tank
- (1) - Located on air purge air tank (if equipped)



**N209334**

- (1) - Located on main air tank
- (1) - Located on air purge air tank (if equipped)



**650431**

- (Located near fuel fill - Final Tier 4 engines only)



**T188283**

- (Located near fan)



**N204628**

- (Located on front left-hand cab post)



**SECTION 2 –  
SAFETY AND PRECAUTIONS**



**HXE19558**  
(Located on inner right-hand side of ladder)

**⚠ CAUTION**

- Keep all shields in place during normal operations.
- Keep hands, feet and clothing away from power-driven parts.
- Disengage power-driven parts and shut off engine before unclogging or servicing machine.
- If service procedure requires engine to be running:
  - Only engage power-driven parts required by service procedure.
  - Ensure other people are clear of operator station and machine.
- Do not leave running machine unattended.

HXE19558

**650504**  
(Located beneath front end cap)



**CRUSH HAZARD.**  
RISK OF INJURY DUE TO IMPROPER OPERATION. REFER TO OPERATOR'S MANUAL FOR INSTRUCTION.

**Spray Boom Decals**

**N203265**  
(2) - Located near each solution tank lid  
(1) - Located on eductor tank lid (if equipped)

**⚠ CAUTION**

Agricultural chemicals can be dangerous. Improper selection or use can injure persons, animals, plants, soils or other property.

**TO AVOID INJURY**

1. Select the right chemical for the job.
2. Handle and apply it with care. Follow instructions issued by the chemical manufacturer.

N203265

**HXE28534**  
(Located on inside of transom)

**⚠ WARNING**

Avoid serious injury from contact with hydraulic oil and gas under pressure. Before removing hydraulic components, disassembling or changing accumulators:

1. Relieve system hydraulic pressures. Refer to Operator Manual and Repair Manual for system information.
2. Stop engine and remove key. Use only DRY NITROGEN for recharging accumulator. See your John Deere dealer.

HXE28534

**650204**  
(Located near each fold point)

**⚠ WARNING**

**Crush Hazard**  
Outer fold extension movement may occur while hydraulic system charges. Stay clear of hazard area. Fully extend or retract fold point before performing maintenance. Failure to comply may result in serious injury or death.

650204

**650210**  
(Located on each NORAC® sensor)





## SECTION 3 – CAB

### SEAT - OPERATOR (STANDARD)

*NOTE: Refer to the seat manufacturer's operating instructions provided on the back side of the operator's seat for further information, including safety precautions and maintenance of seat.*

#### Seat Functions and Operation

- (1) - Weight Adjustment
- (2) - Height Adjustment
- (3) - Fore/Aft Isolator
- (4) - Fore/Aft Adjustment
- (5) - Armrest Adjustment
- (6) - Backrest Extension
- (7) - Lumbar Support
- (8) - Backrest Adjustment
- (9) - Swivel

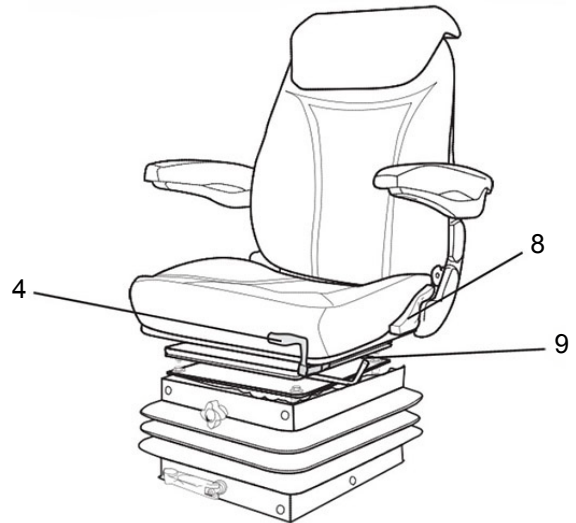
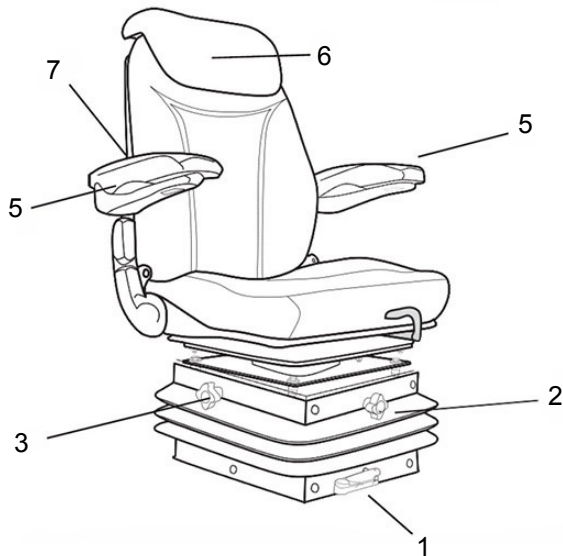

#### Weight Adjustment (1)

The seat must be adjusted for the driver's weight by briefly pulling the actuator switch of the weight adjuster with the machine at a standstill and the driver sitting in the seat.

*NOTE: The operator must remain still during adjustment.*

*NOTE: To prevent health damage, the setting for the driver's weight must be checked and adjusted individually before operating the machine.*

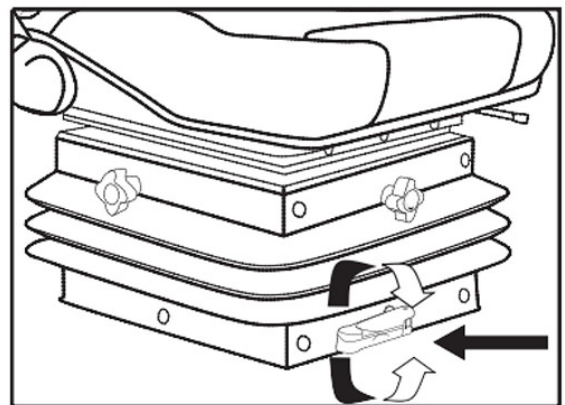

### Height Adjustment (2)

Seat height can be adjusted by pulling or pushing the adjustment lever to lower the seat counter-clockwise, or raise the seat clockwise.

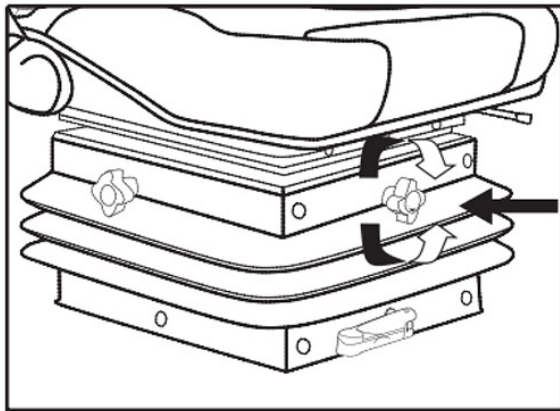

### Fore/Aft Isolator (3)

Under certain conditions (for example, with a trailer attached), it is useful to activate the fore/aft isolator. This means that shock impacts in the driving direction can be better absorbed by the operator's seat.

- Position 1 = Fore/Aft Isolator OFF
- Position 2 = Fore/Aft Isolator ON

After the adjustment of Position 1, the locking lever must latch into desired position. For that, the seat must be pressed backwards until it latches with an audible click.

*NOTE: It is impossible to move the fore/aft isolator into another position when locked.*

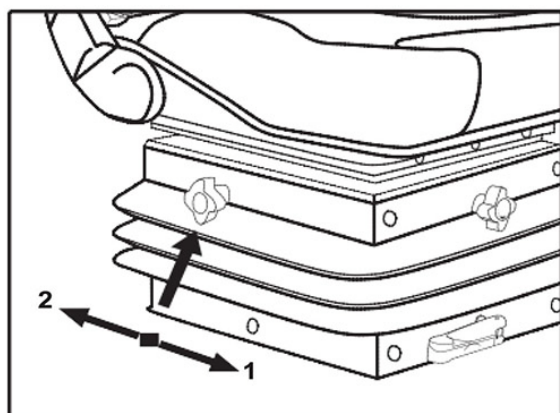

### Fore/Aft Adjustment (4)

**WARNING**

**Risk of Accident!**

Do not operate the locking lever while driving the machine.

The fore/aft adjustment is released by lifting outside the locking lever (left). After the adjustment, the locking lever must latch into the desired position with an audible click.

*NOTE: It is impossible to move the operator's seat to another position when locked.*

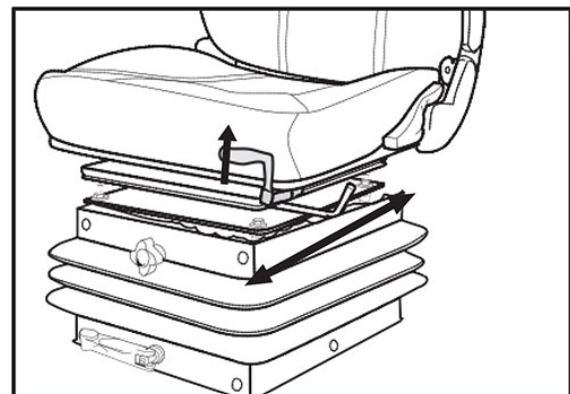

### Armrest Adjustment (5)

Inclination of the armrests can be adjusted by turning the adjustment knob. When turning the knob to the outside, the front part of the armrest will be lifted. When turning the knob to the inside, it will be lowered.

*NOTE: Armrests can be folded upright and stored in the vertical position.*

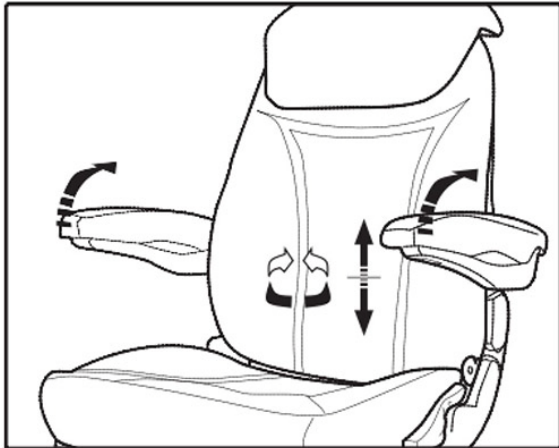

**Backrest Extension (6)**

The backrest extension can be individually adjusted for height by pulling upwards or downwards to desired position. To remove the backrest extension, pull upwards over the end stop.

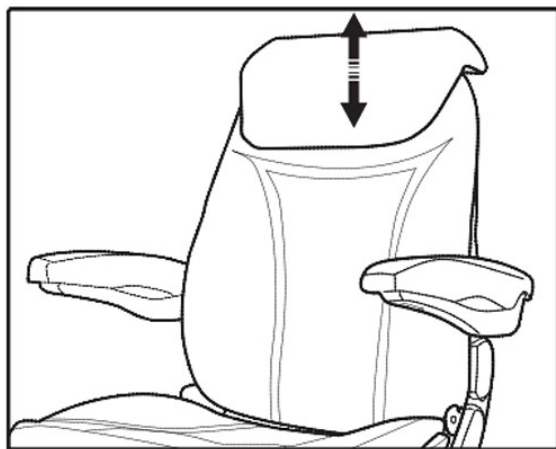

**Lumber Support (7)**

The curvature of the backrest cushion can be individually adjusted by rotating the adjustment knob to the left.

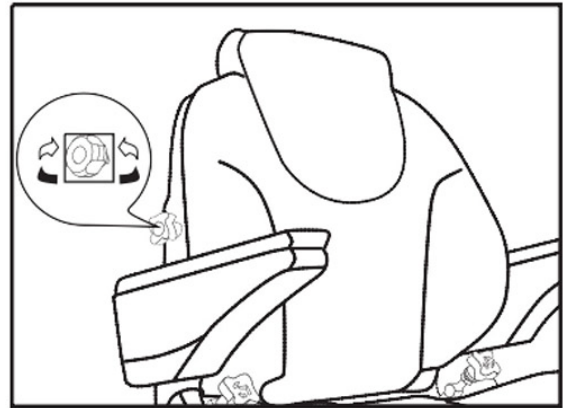

**Backrest Adjustment (8)**

Pull the locking lever to release the backrest catch. When releasing the backrest catch, do not apply load to the backrest by pressing against it. By exerting pressure on or off the front or rear part of the seat pan, the seat can be moved to the desired position. Release the locking lever to lock the backrest into place.

*NOTE: After the lever is locked, the backrest position can no longer be adjusted.*

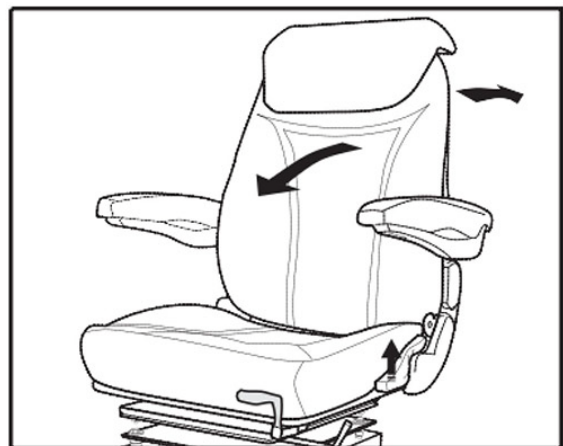

**Swivel (9)**

 <b>WARNING</b>
<b>Risk of Accident!</b> Do not operate the locking lever while driving the machine.



The swivel is released by pulling the locking lever. The seat can then be swiveled by 15° to the left or right 180°. After adjustment, the locking lever must be fixed into the desired position with an audible click.

*NOTE: It is impossible to move the operator's seat to another position when locked.*



### Seat Belt

Refer to "Seat Belt" provided in the *Safety and Precautions Section* elsewhere in this manual for further information.

## SEAT - OPERATOR (PREMIUM)

-If Equipped

### **⚠ WARNING**

This seat may be equipped with a seat heater or ventilation system. There is a possibility that some people may suffer heat-induced burns or excessive cooling when using the system. Do not use either of these systems if you have a diminished ability to sense temperature, a reduced ability to feel pain, or have sensitive skin.

When using the seat heater or ventilation system, do not place anything on the seat that insulates against heat or cooling, such as a blanket, cushion, or similar item. This may cause the seat heater or ventilation system to overheat, which may cause a heat-induced burn or may damage the seat.

Your machine may be equipped with a Premium Air Ride Operator's Seat that is equipped with the following features for your driving and comfort needs.

- (A) - Headrest
- (B) - Heat/Cool Selector Switch
- (C) - Heat/Cool Temperature Switch
- (D) - Armrest Tilt Dial
- (E) - Height Adjustment Switch
- (F) - Recline Lever
- (G) - Slide Release Lever
- (H) - Thigh Tilt Lever
- (I) - Thigh Extension Lever

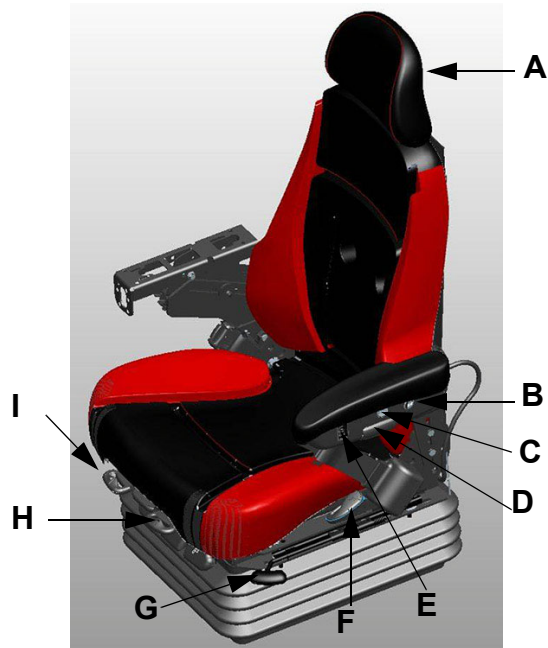

- (J) - Armrest Height Adjuster
- (K) - Fore/Aft Lockout Isolator
- (L) - Lateral Lockout Isolator
- (M) - Ride Firmness Lever



- (N) - Armrest Height/Length Adjuster
- (O) - Lumbar Knob
- (P) - Document Pouch

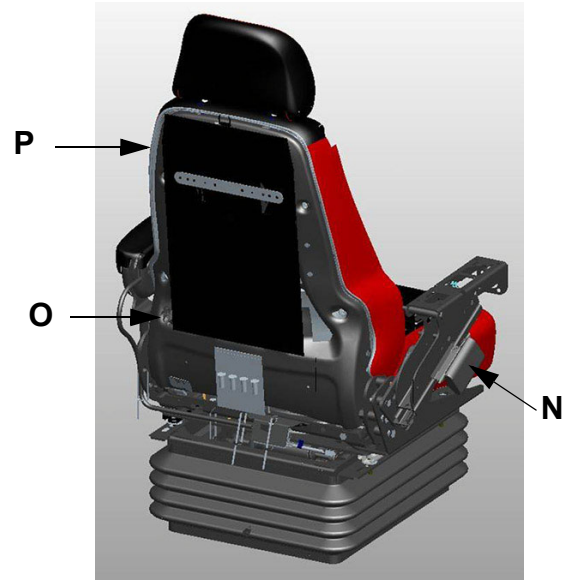

**Headrest (A)**

**(Adjusts height and tilt)**

- Firmly grasp headrest and pull UP for higher adjustment.
- Firmly grasp headrest and push DOWN for lower adjustment.

**Tilt:**

*(First Position: hold and rotate down 10-degrees; Second Position: hold and rotate down 20-degrees; Third Position: hold and rotate down 30-degrees. Hold and rotate down to return Headrest to 0-degree position).*

**Heat/Cool Selector Switch (B)**

**(Selects between heat and cool settings)**

- Press Heat/Cool Selector Switch FORWARD to cool.
- Press Heat/Cool Selector Switch REARWARD to heat.

**Heat/Cool Temperature Switch (C)**

**(Switches heat/cool temperature to high, low, or off settings)**

- Press Heat/Cool Temperature Switch UP for HIGH heat or cool.
- Press Heat/Cool Temperature Switch DOWN for LOW heat or cool.
- Press Heat/Cool Temperature Switch to the MID position to turn OFF.

**Armrest Tilt Dial (D)****(Tilts armrests)**

- Roll Armrest Tilt Dial (located on each side of operator's seat) INWARD (towards operator) to tilt armrest DOWN.
- Roll Armrest Tilt Dial OUTWARD (away from operator) to tilt armrest UP.

**Height Adjustment Switch (E)****(Moves seat up and down)**

- Press Height Adjustment Switch UP to increase seat height.
- Press Height Adjustment Switch DOWN to decrease seat height.

**Recline Lever (F)****(Angles back rest cushion)**

- Pull and hold Recline Lever UP to adjust back rest angle. Release lever when desired angle is achieved.

**Slide Release Lever (G)****(Moves top of seat fore/aft)**

- Pull and hold Slide Release Lever while sliding seat forward or rearward. Release lever when desired position is achieved.

**Thigh Tilt Lever (H)****(Tilts seat cushion up and down)**

- Pull Thigh Tilt Lever UP and hold cushion to adjust +4 degrees. Release lever when desired position is achieved.
- Pull Thigh Tilt Lever UP and push cushion down to adjust -4 degrees. Release lever when desired position is achieved.

**Thigh Extension Lever (I)****(Extends seat cushion fore/aft)**

- Pull Thigh Extension Lever UP and hold to adjust cushion +/- 30 mm. Release lever when desired position is achieved.

**Armrest Height Adjuster (J)****(Adjusts armrest height)**

- Loosen two (2) bolts and move armrests up or down.
- While maintaining desired armrest position, re-tighten bolts.

**Fore/Aft Lockout Isolator (K)****(Locks or unlocks fore/aft isolation)**

- Pull Fore/Aft Lockout Isolator UP to unlock isolation.
- Push Fore/Aft Lockout Isolator DOWN to lock isolation.

**Lateral Lockout Isolator (L)****(Locks or unlocks lateral isolation)**

- Pull Lateral Lockout Isolator UP to lock isolation.
- Push Lateral Lockout Isolator DOWN to unlock isolation.

**Ride Firmness Lever (M)****(Adjusts ride suspension)**

- Pull Ride Firmness Lever UP for a firmer ride.
- Push Ride Firmness Lever DOWN for a softer ride.

**Armrest Height/Length Adjuster (N)****(Adjusts height and length of armrest)**

- Pull and hold Armrest Height/Length Adjuster and slide forward or rearward. Release adjuster when armrest is in desired position.

**Fore/Aft Adjustment:** +/- 76 mm at 12.7 mm increments; **Up/Down Adjustment** +/- 35 mm at 5.4 mm increments.

**NOTE:** Armrest tilt fixed position = 25 degrees.

**Lumbar Knob (O)****(Adjusts lumbar curvature)**

- Rotate Lumbar Knob INWARD (toward operator) for increased curve.
- Rotate Lumbar Knob OUTWARD (away from operator) for decreased curve.

**Document Pouch (P)****(Storage for various machine manuals)**

- Pull Document Pouch Fastener to OPEN.
- Push Document Pouch Fastener to CLOSE.

**Seat Belt**

Refer to "Seat Belt" provided in the *Safety and Precautions Section* elsewhere in this manual for further information.

## SEAT - INSTRUCTOR

The cab is equipped with an Instructor Seat for training operators or diagnosing machine problems. Always wear your seat belt.



Instructor Seat  
-Typical View

A storage compartment is provided behind the seat, as well as a set of cup holders on the back side of the seat for your convenience. Fold seat down to access.



-Typical View

## OPERATOR'S STATION

### Front Console

- (A) - Steering Wheel
- (B) - Hazard/Warning Lights Switch
- (C) - Highway Running Lights Switch
- (D) - Turn Signal Indicator (Left)
- (E) - Highway Running Lights Indicator
- (F) - High Beams Indicator
- (G) - Turn Signal Indicator (Right)
- (H) - Steering Wheel Telescope Adjust Handle, *if equipped*
- (I) - Steering Column Tilt Adjust Button (Knee Angle), *if equipped*
- (J) - Steering Column Release Pedal
- (K) - Operator Foot Pegs (2), *if equipped*
- (L) - Deceleration (Decel) Pedal
- (M) - Horn
- (N) - Windshield Washer
- (O) - Turn Signal Lever
- (P) - Windshield Wiper Speed
- (Q) - High Beams (Brights)

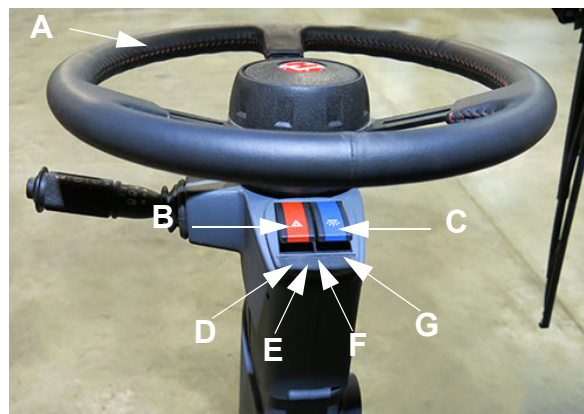

-Typical View



-Typical View  
(If equipped)

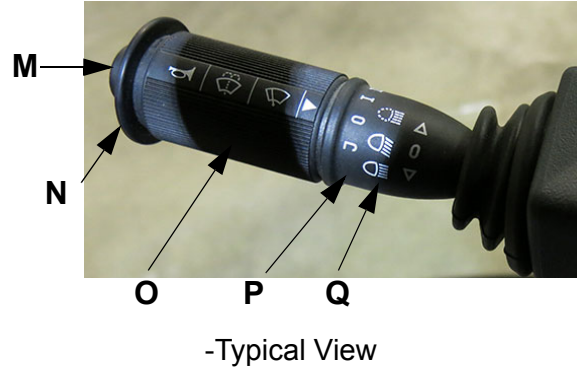

-Typical View

**Hazard/Warning Lights Switch**

The Hazard/Warning Lights (located on the front and rear of machine) are to be used at any time, day or night, that you are traveling on a public roadway, unless prohibited by law.

*NOTE: The Hazard/Warning Lights are tied to battery power and will operate when the machine is off. The flashers are disabled in Field Mode.*

*NOTE: The Hazard/Warning Light Flashers are also activated with the corresponding turn signal.*



-Typical View  
(If equipped)



Front Hazard/Warning Light Flashers (2)  
-Typical View

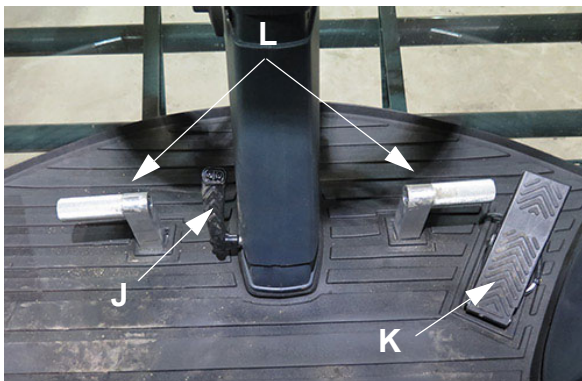

-Typical View

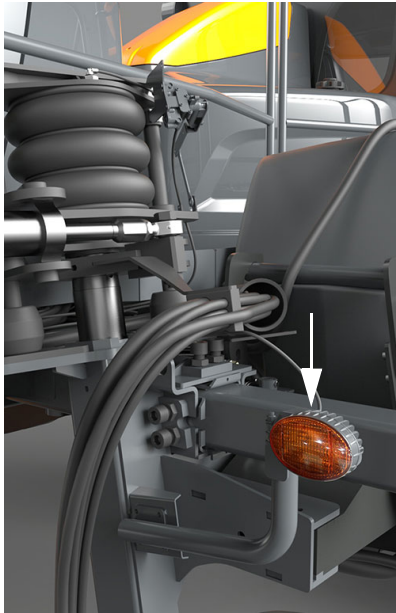

Rear Hazard/Warning Light Flashers (2)  
-Typical View



Hazard/Warning Lights Switch  
(Located on steering column)  
-Typical View

**Highway Running Lights Switch  
(Headlights)**

The Highway Running Lights (located on the front and rear of machine) are to be used when traveling on a public roadway at night.

*NOTE: The Highway Running Lights operate in both Road and Field Mode.*



Rear Hazard/Warning Light Flashers (2)  
-Typical View



Highway Running Lights (2)  
-Typical View

**To activate the Hazard/Warning Lights:**

- Press the Hazard/Warning Lights Switch (located on steering column) in the DOWN (On) position to activate.
- Press the Hazard/Warning Lights Switch in the UP (Off) position to deactivate.

*NOTE: The Rotating Beacon (located on the cab roof) will also activate when the Hazard/Warning Lights Switch is depressed. Refer to “Rotating Beacon” provided in the Safety and Precautions Section elsewhere in this manual for further information.*

The two rear red taillights are activated any time that the headlights are on.



Rear Taillights  
-Typical View

**To activate the Highway Running Lights:**

- Press the Highway Running Lights Switch (located on steering column) in the DOWN (On) position to activate.
- Press the Highway Running Lights Switch in the UP (Off) position to deactivate.

*NOTE: The Highway Running Lights Indicator (located near the steering wheel) will illuminate when activated.*



Highway Running Lights Switch  
(Located on steering column)  
-Typical View

*NOTE: Highway Running Lights are enabled when the key is in the ON position. However, prolonged use of these lights without the engine running is not recommended.*

**Steering Wheel Telescope Adjust**

**-If Equipped**

The Steering Wheel Telescope Adjust allows movement of the upper portion of the steering column to best suit your driving needs.

- To adjust the steering wheel, lift the Steering Wheel Telescope Adjust Handle (located on the right-hand side of steering column) UP to loosen enough to freely move the steering wheel.

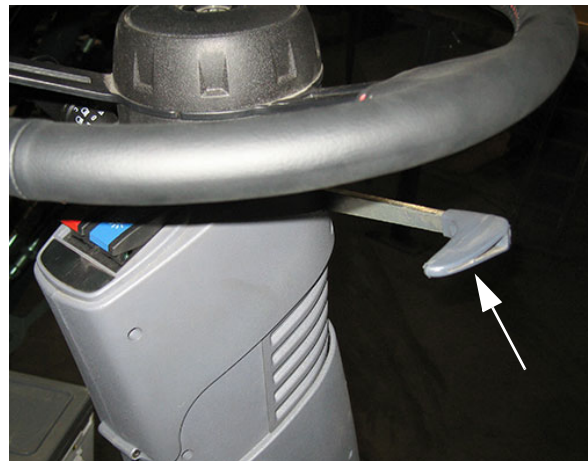

Steering Wheel Telescope Adjust Handle  
(Located on the right-hand side of steering column)  
-Typical View

- With the handle loosened, adjust steering wheel to desired position. While holding the wheel in position, release the Steering Wheel Telescope Adjust Handle to lock into place.

**Steering Column Tilt Adjust  
(Knee Angle)**

**-If Equipped**

The Steering Column Tilt Adjust allows you to angle the top section of the steering column to the position that best suits your comfort needs.

**To tilt top section of steering column down:**

- Lift and hold the Steering Column Tilt Adjust Button (located on the left-hand side of the steering column) in the UP position.



Steering Column Tilt Adjust Button  
(Located on the left-hand  
side of the steering column)  
-Typical View

- While maintaining the Steering Column Tilt Adjust Button in the upward position, pull steering wheel BACKWARD (towards the operator).
- Release button when steering column is in the desired position.

**To tilt top section of steering column up:**

- Lift and hold the Steering Column Tilt Adjust Button (located on the left-hand side of the steering column) in the UP position.
- While maintaining the Steering Column Tilt Adjust Button in the upward position, allow steering wheel to move FORWARD (away from the operator).
- Release button when steering column is in the desired position.

**Steering Column Release Pedal**

**⚠ CAUTION**

Ensure the steering wheel and steering column are in the locked position before attempting to operate the machine. Failure to comply may result in difficulty maintaining control of the machine.

The Steering Column Release Pedal is featured for ease of exiting and entering the cab.

- With your foot on the Steering Column Release Pedal (located on the lower left-hand side of the steering column), push pedal DOWN and move the steering column to desired position.



Steering Column Release Pedal  
(Located on the lower left-hand  
side of the steering column)  
-Typical View

- To lock the steering column in desired position, remove your foot from the Steering Column Release Pedal while holding the steering column in place.
- Once the steering column has engaged into locked position, firmly move the steering column in either direction to ensure security.



### Operator Foot Pegs

#### -If Equipped

Operator Foot Pegs are located on each side of the steering column to provide added comfort and stability while operating the machine.

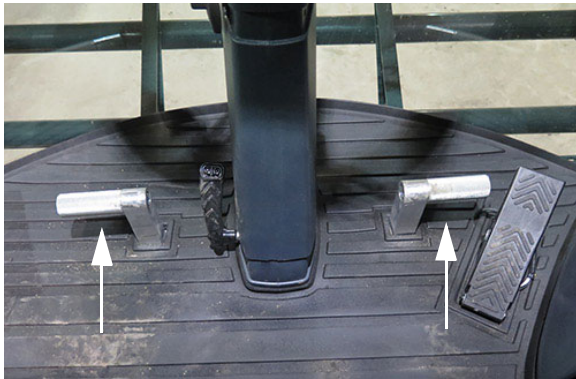

Operator Foot Pegs  
(Located on each side  
of the steering column)  
-Typical View

### Deceleration (Decel) Pedal

 <b>WARNING</b>
Decel Pedal is NOT a brake. It is designated for speed reduction only.

When nearing an end row and speed deceleration is desired, press the Decel Pedal (located to the lower right-hand side of the steering column) to decrease speed.

*NOTE: When the Decel Pedal is fully pressed, vehicle speed decreases to 0.*



Decel Pedal  
(Located to the lower right-hand  
side of the steering column)  
-Typical View

### Horn

The Horn is sounded by pressing the Horn Button (located on the end of the turn signal lever) INWARD.



Horn Button  
(Located on the end of  
the turn signal lever)  
-Typical View

### Windshield Washer

The Windshield Washer Button is located on the end of the turn signal lever. To apply washer fluid, press and hold button in the IN position. Release button when desired amount of fluid is dispensed.

*NOTE: Ensure there is adequate amount of washer fluid in the windshield washer fluid reservoir (located behind the left-hand side of cab) before operating.*



Windshield Washer Button  
(Located on the end of  
the turn signal lever)  
-Typical View



Turn Signal Lever  
-Typical View

*NOTE: Steering column-mounted and  
Machine Display indicator lights will  
flash correspondingly when either  
turn signal is activated.*

### Windshield Wiper Speed

To increase or decrease Windshield Wiper speed, rotate the turn signal lever forward or backward to achieve Hi, Low, or Intermittent wiper speed.



Windshield Wiper Speeds  
(Located on the turn signal lever)  
-Typical View

### High Beams (Brights)

- To turn the High Beams ON, push the turn signal lever (located on the left-hand side of the steering column) DOWN.
- To turn the High Beams OFF, push the turn signal lever UP.

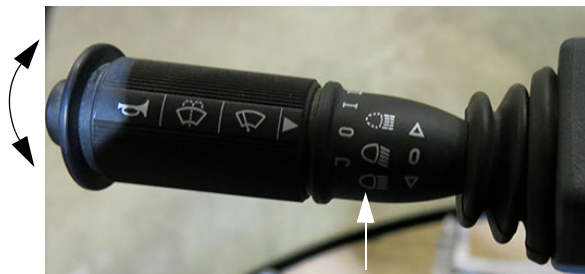

High Beams  
(Located on the turn signal lever)  
-Typical View

### Turn Signals

To activate the front and rear Turn Signals, move the Turn Signal Lever (located on the left-hand side of the steering column) FORWARD (away from operator) to signal a right turn, or BACKWARD (toward operator) to signal a left turn.

*NOTE: The machine's drive state must be in  
Road Mode to activate the Turn  
Signals.*

### Side Console

- (A) - Emergency Stop Switch
- (B) - Foam Marker Switch (if equipped)
- (C) - Night Spray Switch (if equipped)
- (D) - Tank Rinse Switch
- (E) - Boom Solution Valve Switches
- (F) - Fence Row Switch (Left)
- (G) - Rate Control Switches
- (H) - Rear Nozzle Switch
- (I) - Pump Speed/Rate Switches
- (J) - Fence Row Switch (Right)
- (K) - Tank Valve Selector Switch (Left)
- (L) - Solution Pump Switch
- (M) - Agitation Valve Switch

- (N) - Tank Valve Selector Switch (Right)
- (O) - Boom Extension Switches
- (P) - Traction Valve Switch
- (Q) - Ignition Switch
- (R) - Power Mirror Switch (if equipped)
- (S) - Hydrostatic Drive Control Handle
- (T) - Transom Switch - Up/Down
- (U) - Left-Hand Boom Switch
- (V) - Right-Hand Boom Switch
- (W) - Master Spray Switch
- (X) - End Row Management Switch
- (Y) - Shift Up Switch
- (Z) - Shift Down Switch
- (AA) - Parking Brake Switch
- (BB) - Throttle Switch
- (CC) - Auxiliary 2 Audio Input Connection
- (DD) - USB Dual Power Port (Charger)
- (EE) - 12V Power Ports

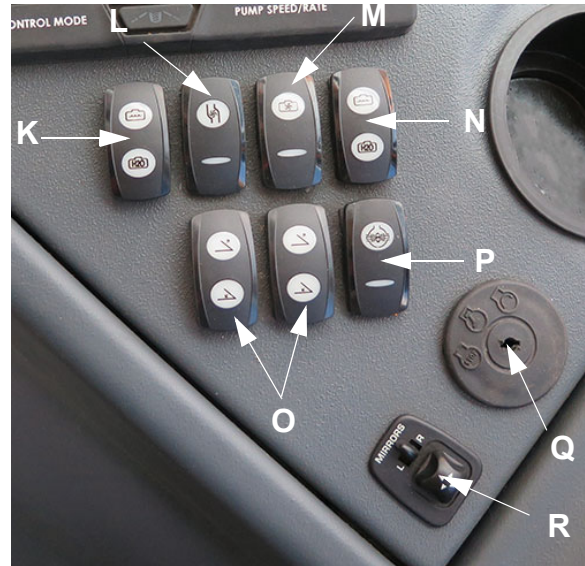

-Typical View

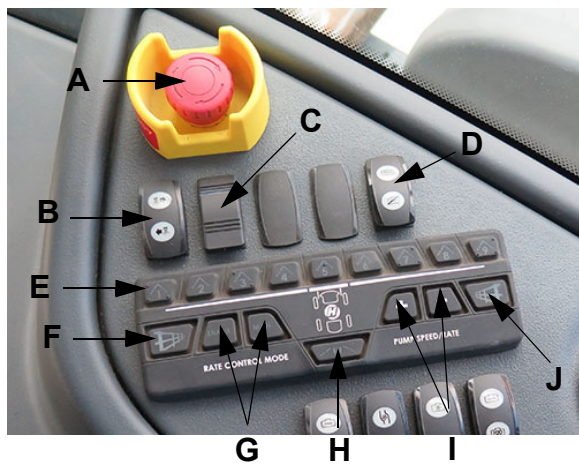

-Typical View

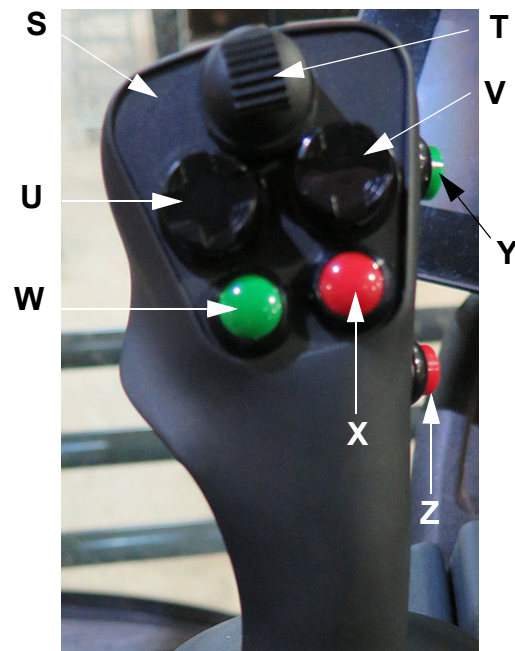

-Typical View

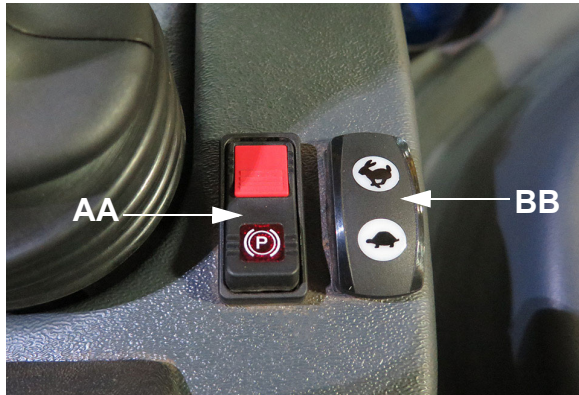

-Typical View



E-Stop Switch  
(Located on the side console)  
-Typical View

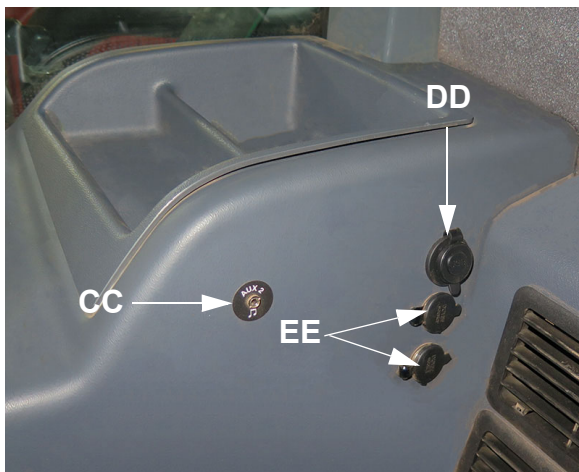

-Typical View

Refer to the *Safety and Precautions* Section provided elsewhere in this manual for further information.

### Foam Marker Switch

#### -If Equipped

The Foam Marker Switch (located on the side console) controls foam application on both sides of the machine.



Foam Marker Switch  
(Located on the side console)  
-Typical View

### Emergency Stop (E-Stop)

The E-Stop Switch (located on the side console) provides a quick and positive method for stopping the engine in an emergency situation.

## NOTICE

Do not use the E-Stop Switch for non-emergency stopping or as a parking brake.

Refer to “Foam Marker” provided in the *Spray Systems* Section elsewhere in this manual for further information.

## Night Spray Switch

### -If Equipped

The Night Spray Switch (located on the side console) is used to turn the Night Spray Lights (located on the rear of cab) on/off.



Night Spray Switch  
(Located on the side console)  
-Typical View

*NOTE: An additional Night Spray Switch is located on the switch box near the ladder for your convenience.*

Refer to “Lighting” provided elsewhere in this section for further information.

## Tank Rinse Switch

The two-position Tank Rinse Switch (located on the side console) opens and closes the valve supplying the tank rinse nozzles. Depending on which tank(s) are selected using the Tank Valve Selector Switches (main tank(s) or rinse tank) will determine whether rinse water from the rinse tank or product from the solution tanks will be circulated.

*NOTE: If only the tank(s) are desired, ensure the boom section valves are disabled via the Master Spray Switch (located on the Hydrostatic Drive Control Handle).*



Tank Rinse Switch  
(Located on the side console)  
-Typical View

Refer to “Rinse System” provided in the *Spray Systems Section* elsewhere in this manual for further information.

## Boom Solution Valve Switches

The Boom Solution Valve Switches (located on the side console) each control a valve located on the boom or transom. The valves control the flow of the solution through the boom.



Boom Solution Valve Switches  
(Located on the side console)  
-Typical View

The boom is divided into sections, with the far left tip being the beginning of the first section. Each Boom Solution Valve Switch is equipped with an indicator light and will illuminate red when manually turned off.

## SECTION 3 – CAB



Refer to the *Spray Systems Section* elsewhere in this manual for further information.

### Fence Row Switches (Left/Right)

The Fence Row Switches (located on the side console) are used in the selection of either the right or left fence row spray nozzle.



Fence Row Switches - Left/Right  
(Located on the side console)  
-Typical View

Refer to “Fence Row Application” provided in the *Spray Systems Section* elsewhere in this manual for further information.

### Rate Control Switches

The Rate Control Switches (located on the side console) control the rate in which solution is applied through the spray booms by either the rate controller (Enable) or operator-controlled spray rate (Manual).

**NOTE:** When both “MAN” and “ENABLE” Rate Control Switches are pressed, manual rate control is activated through the rate controller.



Rate Control Switches  
(Located on the side console)  
-Typical View

Refer to the *Spray Systems Section* elsewhere in this manual for further information.

### Rear Nozzle Switch

The Rear Nozzle Switch (located on the side console) controls the two (2) rear nozzles (located behind the rear tires).



Rear Nozzle Switch  
(Located on the side console)  
-Typical View

Refer to the *Spray Systems Section* elsewhere in this manual for further information.

### Pump Speed/Rate Switches

The Pump Speed/Rate Switches (located on the side console) allow you to increase or decrease flow rate through the spray system.

**NOTE:** When the “MAN” Rate Control Switch is pressed, the Pump Speed/Rate Switches increase or decrease pump speed/application rate from the Hagie control system. When the “ENABLE” Rate Control Switch is pressed (with either “MAN” active or inactive), a third party rate controller increases or decreases pump speed/application rate.



Pump Speed/Rate Switches  
(Located on the side console)  
-Typical View

Refer to the *Spray Systems Section* elsewhere in this manual for further information.

### Tank Valve Selector Switches (Left/Right)

The Tank Valve Selector Switches (located on the side console) are three-position switches that allow the operator to pull from either the solution tank(s) or the rinse tank.

**NOTE:** Both left and right Tank Valve Selector Switches must be in the DOWN (Rinse Tank) position for the rinse tank to be selected.

**NOTE:** The third position (middle) is OFF (no tank selected).

**NOTE:** In addition to the Tank Valve Selector Switches inside the cab, the Left/Right Tank Valve Switches (located on the switch box near the ladder) must also be in the ON position to enable spray application.



Tank Valve Selector Switches - Left/Right  
(Located on the side console)  
-Typical View

Refer to the *Spray Systems Section* elsewhere in this manual for further information.

### Solution Pump Switch

The Solution Pump Switch (located on the side console) is used to turn the Solution Pump on/off.



Solution Pump Switch  
(Located on the side console)  
-Typical View

**NOTE:** Leaving the Solution Pump Switch in the ON position can cause the pump to run continuously, which may result in system damage.

## SECTION 3 – CAB



Refer to the *Spray Systems Section* elsewhere in this manual for further information.

### Agitation Valve Switch

The Agitation Valve Switch (located on the side console) controls the rate of flow through the Agitation System.



Agitation Valve Switch  
(Located on the side console)  
-Typical View

Refer to the *Spray Systems Section* elsewhere in this manual for further information.

### Boom Extension Switches (Outer Fold)

**⚠ WARNING**

When operating or positioning the booms, observe the following safety precautions to avoid serious injury or death:

- Select a safe area before folding/unfolding booms.
- Clear area of personnel.
- Check for overhead obstructions.
- Do not fold/unfold booms near power lines. Contact with power lines can result in serious injury or death.



**⚠ CAUTION**

When operating or positioning the booms, observe the following safety precautions to avoid injury or equipment damage.

- Do not fold/unfold boom extensions when main boom is in cradle.
- Do not operate sprayer with one boom out of cradle and the other boom in cradle.
- Do not transport machine without booms folded and in cradle.

The Boom Extension Switches (located on the side console) are used to extend or retract the outer fold sections.



Boom Extension Switches - Left/Right  
(Located on the side console)  
-Typical View

Refer to the *Spray Systems Section* elsewhere in this manual for further information.



### Traction Valve Switch

The Traction Valve Switch (located on the side console) is used to enable traction control on your machine. When the switch is depressed, the left wheels will move at the same speed, and the right wheels will move at the same speed.

- Press the Traction Valve Switch in the UP (On) position to enable traction control.

*NOTE: Once the Traction Valve Switch is depressed, traction control will activate for approximately 30 seconds, or until the switch is pressed again.*



Traction Valve Switch  
(Located on the side console)  
-Typical View

When traction control is active, a Traction Valve Indicator (located on the Machine Display Home Page - Road and Field Mode) will illuminate.

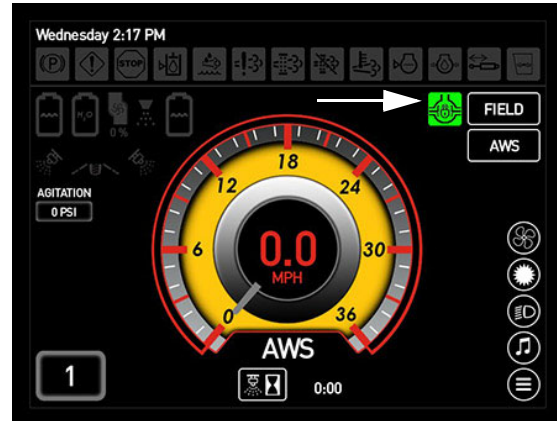

Traction Valve Indicator  
(Located on the Machine Display  
Home Page - Road and Field Mode)  
-Typical View

### Ignition Switch

The Ignition Switch (located on the side console) has three positions - OFF, ON, and START. Before engaging the starter, turn the ignition key to the ON position and wait for the “wait to start” message to disappear on the Machine Display.

*NOTE: The parking brake must be engaged before engaging the starter.*

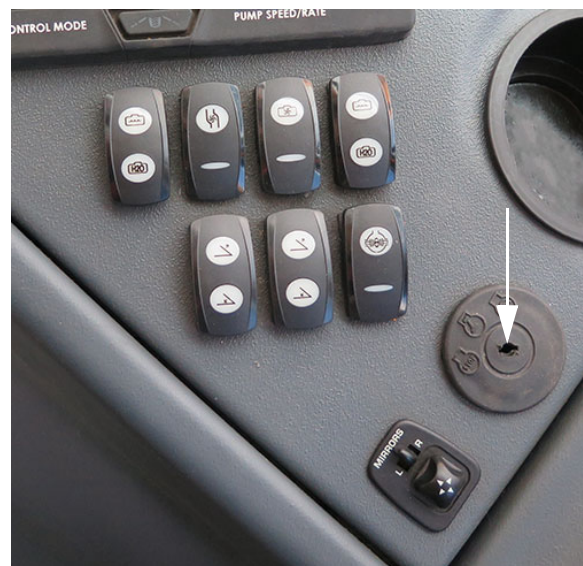

Ignition Switch  
(Located on the side console)  
-Typical View

- **To engage the starter**, turn the key to the START position and hold momentar-

## SECTION 3 – CAB



ily until the engine engages. If the engine does not engage after 15 seconds, turn the key to the OFF position.

*NOTE: Constant cranking of the starter will cause damage to the battery and starting system.*

### Power Mirrors

#### -If Equipped

Your machine may be equipped with Power Mirrors for your operating convenience.

- Press the L/R Lever in the “L” position to adjust the LEFT mirror or in the “R” position to adjust the RIGHT mirror.
- Press the Adjust Switch to adjust the corresponding mirror to desired position.

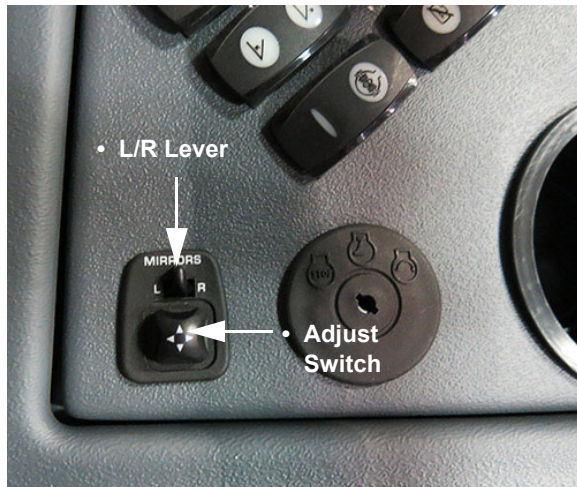

Power Mirror Switch  
(Located on the side console)  
-Typical View

### Hydrostatic Drive Control Handle

The Hydrostatic Drive Control Handle controls the direction of the machine and the speed in which it travels. It is also used to control the spray booms, master spray, end row management, and shift up/down speeds.

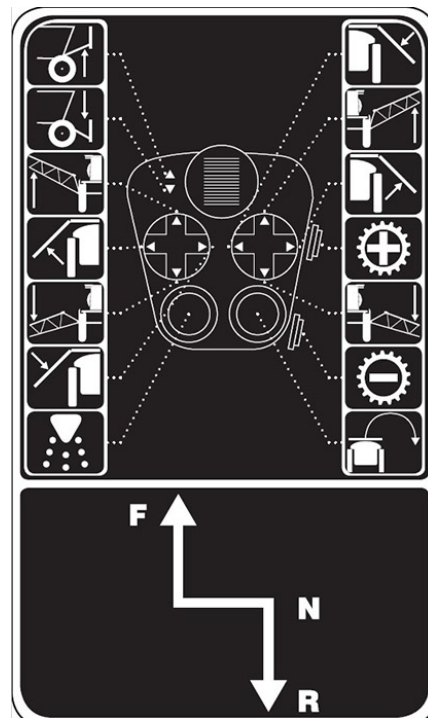

Hydrostatic Drive Control Handle  
-Typical View

Refer to the *Engine and Drive Systems and Spray Systems Sections* elsewhere in this manual for further information.

### Transom Switch - Up/Down

The Transom Switch (located on the Hydrostatic Drive Control Handle) is used to raise and lower the main lift.

### Left and Right-Hand Boom Switches

The Left and Right-Hand Boom Switches (located on the Hydrostatic Drive Control Handle) are used to raise, lower, extend, and retract the spray booms.

### Master Spray Switch

The Master Spray Switch (located on the Hydrostatic Drive Control Handle) activates the boom solution valves.

### End Row Management Switch

The End Row Management Switch (located on the Hydrostatic Drive Control Handle) is a programmable switch that enables various functions (i.e. All-Wheel Steer, Auto Steer, Master Spray, NORAC® Enable, and Return to Height) when the switch is depressed.

*NOTE: End Row Management functions are disabled in Road Mode.*

Refer to “Machine Display” provided elsewhere in this section for programming information.

### Shift Up/Down Switches

The Shift Up/Down Switches (located on the Hydrostatic Drive Control Handle) are used for speed range selection.

Refer to “Hydrostatic Drive” provided in the *Engine and Drive Systems Section* elsewhere in this manual for further information.

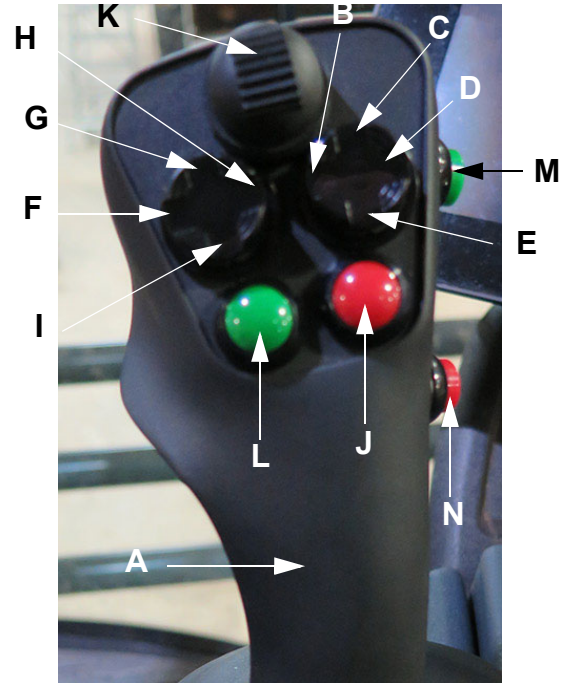

- (A) - Hydrostatic Drive Control Handle
- (B) - Right-Hand Boom IN
- (C) - Right-Hand Boom UP
- (D) - Right-Hand Boom OUT
- (E) - Right-Hand Boom DOWN
- (F) - Left-Hand Boom OUT
- (G) - Left-Hand Boom UP
- (H) - Left-Hand Boom IN
- (I) - Left-Hand Boom DOWN
- (J) - End Row Management Switch
- (K) - Transom Switch
- (L) - Master Spray Switch
- (M) - Shift Up Switch
- (N) - Shift Down Switch

### Parking Brake Switch

## CAUTION

Do not engage the parking brake while the machine is moving. Failure to comply may result in personal injury and machine damage.

**NOTICE**

The parking brake is not intended for normal or emergency stopping.

The Parking Brake Switch (located near the Hydrostatic Drive Control Handle) is used to engage/disengage the parking brake, as well as extend/retract the ladder.

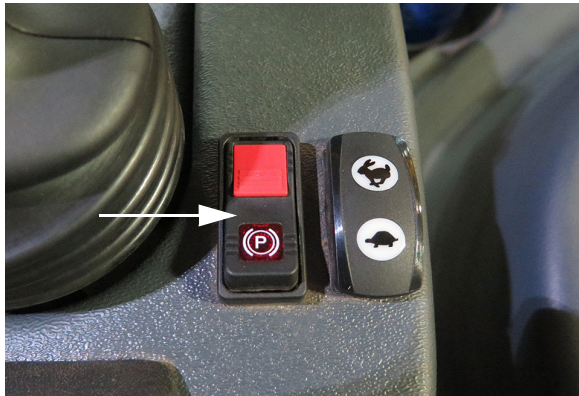

Parking Brake Switch  
(Located near the Hydrostatic  
Drive Control Handle)  
-Typical View

Refer to “Hydrostatic Drive” provided in the *Engine and Drive Systems Section* elsewhere in this manual for further information.

### Throttle Switch

The Throttle Switch (located near the Hydrostatic Drive Control Handle) is used to control engine speed (RPM).

*NOTE: The operator may select throttle setting by operating the Throttle Switch. However, engine speed is also controlled by movement of the Hydrostatic Drive Control Handle.*

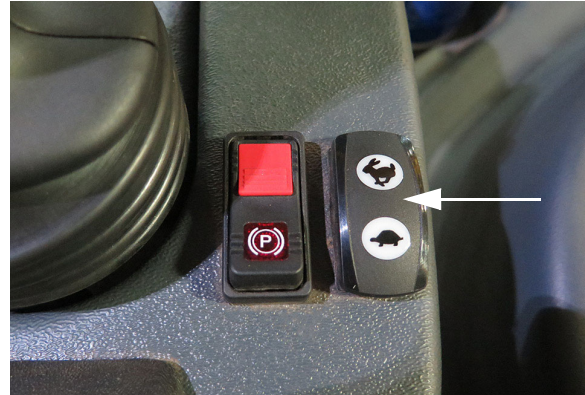

Throttle Switch  
(Located near the Hydrostatic  
Drive Control Handle)  
-Typical View

*NOTE: Engine speed can range between 850 and 2500 RPM in both Road and Field Mode.*

The Throttle Switch works with a timer to tell the engine how fast to run. The longer the operator holds the switch in either direction (press UP/“rabbit icon” to increase the speed, press DOWN/“turtle icon” to decrease the speed), the more the engine will speed up or slow down.

### Auxiliary Audio Input Connection (Aux 2)

The Aux 2 Audio Input Connection (located on the inward side console panel) allows you to connect a personal i-Pod or MP3 player.

*NOTE: An Aux 1 Audio Input Connection is located on the stereo/radio.*

### USB Dual Power Port (Charger)

The USB Dual Power Port (located on the inward side console panel) is a 1.5 A charge port to allow you to charge your phone or tablet.

### Power Ports (12-Volt)

Three (3) Power Ports (two located on the inward side console panel and one located along the lower left-hand side of operator’s seat) are provided for the connection of additional items, such as radios and computer equipment.

*NOTE: The Power Ports are not intended for the permanent connection of additional systems to the sprayer.*

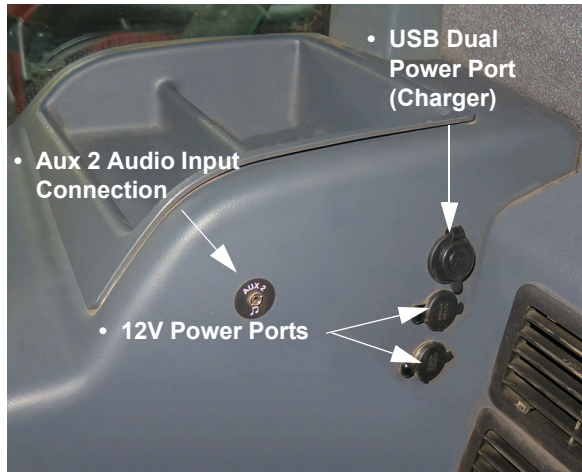

-Typical View



-Typical View



-Typical View

### Overhead Monitors and Controls

- (A) - Courtesy Light/Interior Work Light
- (B) - Stereo
- (C) - Climate Controls
- (D) - NORAC Monitor
- (E) - Precision Display
- (F) - Machine Display
- (G) - Machine Gauges



-Typical View



-Typical View



-Typical View  
*(Your machine may vary, depending on model and available equipment)*



-Typical View



-Typical View

### **Courtesy Light/Interior Work Light**

The Courtesy Light comes on automatically when the cab door is opened.

The Interior Work Light is activated by manually by pressing the Interior Work Light Switch (located on the light housing).

- Press switch UP to turn interior “white” light ON.
- Press switch DOWN to turn interior “red” light ON.
- Press switch in the mid-position to turn OFF.



Interior Work Light Switch  
-Typical View

### **Stereo**

The Stereo in your cab is featured with an AM/FM Tuner, Weatherband Broadcasting, MP3 Player, USB/iPod Controls, and Bluetooth®.

Refer to the Stereo manufacturer’s owner’s manual for complete operating instructions and programming information.



### Climate Controls (Standard)



-Typical View

#### Fan Blower Speed (A)

- Rotate the Fan Blower Speed Dial “clockwise” to increase fan speed.
- Rotate the Fan Blower Speed Dial “counter-clockwise” to decrease fan speed.
- To shut the fan off, rotate the Fan Blower Speed Dial fully “counter-clockwise”.

#### Temperature Setting (B)

- Rotate the Temperature Setting Dial “clockwise” to increase temperature.
- Rotate the Temperature Setting Dial “counter-clockwise” to decrease temperature.

#### Air Conditioner Switch (C)

- To activate the air conditioner, press the Air Conditioner Switch in the ON position (toward switch indicator).  
Adjust the fan speed and temperature accordingly.

### Climate Controls (Optional)

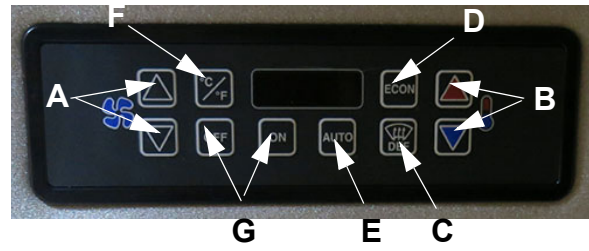

-Typical View

#### Fan Up/Down (A)

The Fan Up/Down Switches control the fan speed up or down in 11 increments and overrides the automatic fan speed control.

- Press desired switch UP to increase fan speed, or DOWN to decrease fan speed.
- The Digital Display indicates the fan speed setting as a percentage, or “HI” when maximum fan speed is obtained, or “LO” when minimum fan speed is obtained.

*NOTE: The Digital Display will return to the normal display five seconds after either key is depressed.*

*The set point fan speed is maintained until it is changed, or until the Auto Mode Switch is depressed.*

#### Temperature Up/Down (B)

The Temperature Up/Down Switches increments the cab set point temperature.

- Press desired switch UP to increase temperature, or DOWN to decrease temperature.

#### Defrost (C)

The Defrost Switch energizes the A/C system to allow for rapid cab dehumidification.

- Press the Defrost (DEF) Switch to turn ON.

*NOTE: An indicator light will illuminate when defrost mode is active.*

#### Economy Mode (D)

Economy Mode uses fresh air, fan speed, and water valve control to maintain the set point temperature. When active, A/C function is disabled.

## SECTION 3 – CAB



- Press the Econ Switch to turn ON.
- Press the Econ Switch again to return the system back to normal operation.

*NOTE: An indicator light will illuminate when Economy Mode is active.*

### Auto Mode (E)

Auto Mode allows the system to function in fully automatic temperature control mode, including automatic fan speed control. The system will adjust the fan speed to the lowest setting required to maintain cab set point temperature.

- Press the Auto Switch to turn ON and OFF.

*NOTE: An indicator light will illuminate when auto mode is active.*

### Cab Temperature (F)

- Press the Cab Temp Switch to display set point on the Digital Display.

*NOTE: Press the Cab Temp Switch and toggle between celsius (C) and fahrenheit (F) temperatures.*

*NOTE: Current cab temperature will be displayed for five seconds, then will return to the set point temperature display.*

### On/Off (G)

- The On/Off Switches power the cab heater/air conditioner systems ON or OFF.

*NOTE: An LED numeric display is illuminated when the unit is turned on. The Digital Display will show the current set point temperature.*

### Cab Vents

Your cab is equipped with adjustable vents. Rotate to desired position, or individually turn on or off with the directional fins.



Cab Vent  
-Typical View

### Precision Display

The spray system is controlled by the Precision Display and the Solution Pump Control Valve. The system receives data and automatically makes adjustments based on the target rate of application set by the operator.



Precision Display  
-Typical View  
*(Your machine may vary,  
depending on available equipment)*

Refer to the manufacturer's operation manual for complete operating instructions and programming information.

### NORAC Monitor

#### -If Equipped

The NORAC Monitor controls the automatic boom leveling system.





NORAC Monitor  
-Typical View

Refer to the manufacturer's operation manual for complete operating instructions.

### Machine Display

The Machine Display in your sprayer is the central control center of the machine. It controls many of the machine's electronically-driven functions (e.g. machine drive, AWS, attachment operation, tread adjustment, spray systems, lights, diagnostics, etc.)



Machine Display  
-Typical View

Refer to “Machine Display” provided elsewhere in this section for a complete list of features and operating instructions.

### Machine Gauges

Machine Gauges are located on the A-post in your cab and are conveniently placed for viewing machine diagnostics.

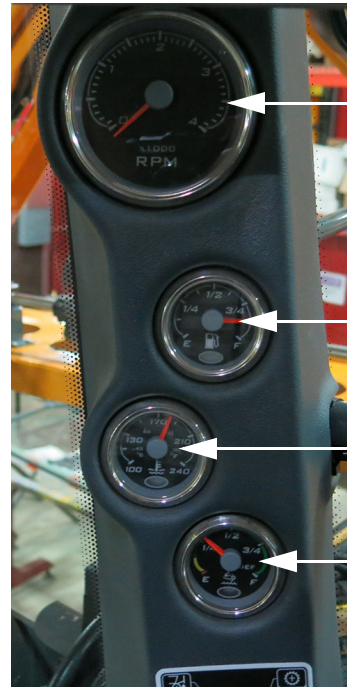

- Tachometer (RPM Gauge)
- Fuel Gauge
- Engine Coolant Gauge
- After-treatment Gauge (if equipped)

Machine Gauges  
(Located on cab A-post)  
-Typical View

### Lighting

*NOTE: See Front Console components discussed earlier in this section for information on Hazard/Warning Lights and Highway Running Lights.*

### Field Lights

The Field Lights (located on the front of cab) are for use when operating in the field after dark and are turned on/off through the Machine Display.

*NOTE: Turn the Field Lights OFF before entering a public roadway.*

## SECTION 3 – CAB



- Field Light 1
- Field Light 2
- Field Light 2
- Field Light 1



Field Lights  
(Located on the front of cab)  
-Typical View

**NOTE:** The ignition key must be in the ON position to operate the Field Lights.

Refer to “Machine Display” provided elsewhere in this section for operating instructions.

### Work/Night Spray Lights

The Work/Night Spray Lights (located on the underside of each boom wing and on each side of the main boom fold section) are for use when operating in the field after dark and are turned on/off through the Machine Display. The Work/Night Spray Lights are adjustable and may be positioned to light up the boom cradles and ground spray pattern.

**NOTE:** Turn the Work/Night Spray Lights OFF before entering a public roadway.

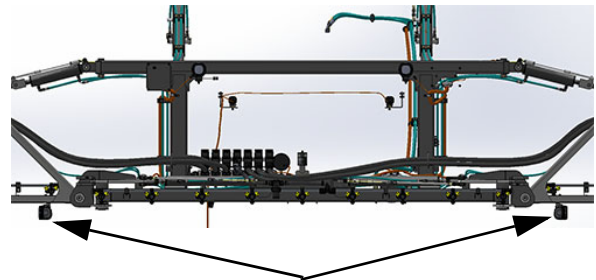
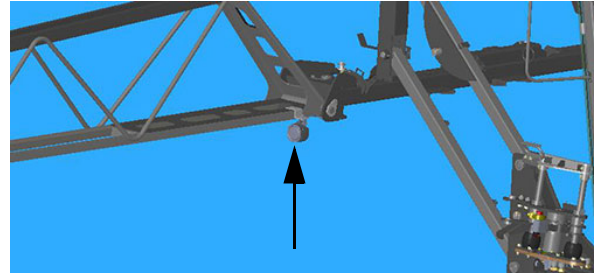

Work/Night Spray Lights  
(Located on the underside of each boom wing and on each side of the main boom fold section)  
-Typical View

**NOTE:** The ignition key must be in the ON position to operate the Work/Night Spray Lights.

Refer to “Machine Display” provided elsewhere in this section for operating instructions.

### Attachment Lights

#### -If Equipped

The Attachment Lights (located on the front of transom) are for use when operating in the field after dark and are turned on/off through the Machine Display.

**NOTE:** Turn the Attachment Lights OFF before entering a public roadway.



**Attachment Lights**  
(Located on the front of transom)  
-Typical View

*NOTE: The ignition key must be in the ON position to operate the Attachment Lights.*

Refer to “Machine Display” provided elsewhere in this section for operating instructions.

### **Platform Lights**

The Platform Lights (located on the rear of cab) are for use when operating in the field after dark and are turned on/off by the Night Spray Switch - located in two separate locations:

- 1. On the side console.**
- 2. On the side of switch box near ladder.**

The Platform Lights are adjustable and may be positioned as desired to light up the work platforms. The lights are run on battery power and may be turned on when climbing up onto the machine in the dark and assist in getting to the cab area safely.



**Platform Lights (2)**  
(Located on the rear of cab)  
-Typical View

### **To Activate the Platform Lights**

*NOTE: The Battery Disconnect Switch (located on the rear mainframe) must be in the ON position to activate the Platform Lights.*

- Press the desired Platform Lights Switch in the UP or DOWN position to operate.



**Platform Lights Switch**  
(Located on the side console)  
-Typical View



**Platform Lights Switch**  
(Located on side of switch box near ladder)  
-Typical View

*NOTE: The Platform Lights Switches in the cab and on the switch box near the ladder operate similar to a 3-way switch in a house - both switches can turn the Platform Lights on or off, but the position of the switches will not always correspond to a specific “on” or “off” state, as the state of each switch is dependent on the other.*

*NOTE: Turn the Platform Lights OFF before entering a public roadway.*

## **Cab Filtration**

### **RESPA® Cab Filter**

Your cab is featured with a dust and aerosol filtration system to provide continuous positive pressure in the cab by reducing exposure to harmful particulates.

*NOTE: The filtration system will activate automatically approximately 10 seconds after machine start-up.*

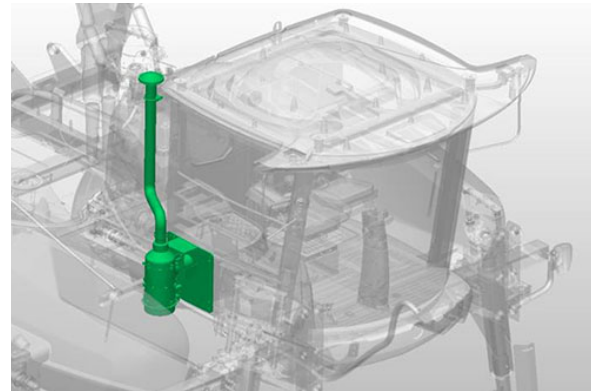

**Cab Filtration System**  
(Located on the right-hand side of the exterior cab)  
-Typical View

An indicator light (located on the Machine Display Home Page) will appear if insufficient cab air pressure should occur.

*NOTE: The Insufficient Cab Air Pressure Indicator will appear each time the machine is started due to the initial activation delay. The indicator will disappear once the cab becomes pressurized.*

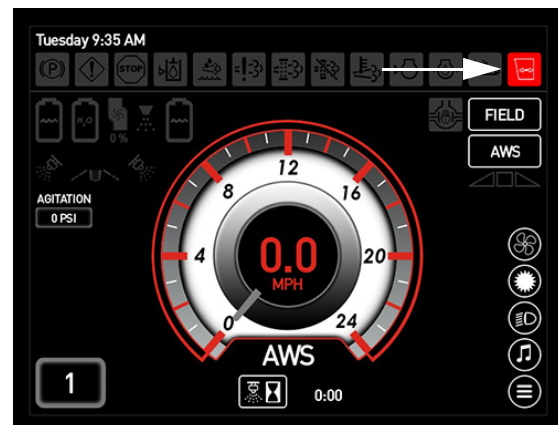

**Insufficient Cab Air Pressure Indicator**  
(Located on the Machine Display Home Page - Road or Field Mode)

Refer to “Service - Filters” provided in the *Maintenance and Storage Section* elsewhere in this manual for filter replacement information.

### Charcoal/Recirculation Filters

Your cab is featured with a Charcoal Filter (located behind the exterior service panel on the right-hand side of cab), which eliminates hazardous chemicals from the operator's station. In addition, a Recirculation Filter (accessible after the Charcoal Filter has been removed) is provided to cleanse air inside the cab, keeping the operator's environment fresh.



Charcoal Filter  
(Located behind the exterior service panel on the right-hand side of cab)  
-Typical View

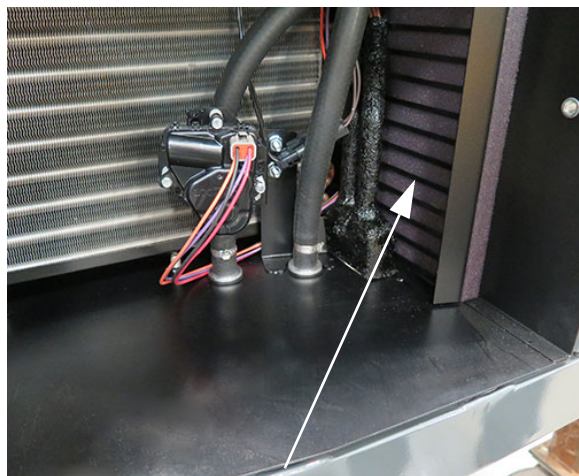

Recirculation Filter  
(Located along the right-hand side of service compartment)  
-Typical View

*\* View shown with charcoal filter removed*

Refer to "Service - Filters" provided in the *Maintenance and Storage Section* elsewhere in this manual for further information on filter maintenance.

### Additional Features

#### Portable Electric Cooler

##### -If Equipped

Your machine may be equipped with a Portable Electric Cooler (located beneath the Instructor Seat) for your personal convenience. A 12-volt connection outlet is provided along side of the operator's seat.

---

### MACHINE DISPLAY

The Machine Display is the central control center of the machine. It controls many of the machine's electronically-driven functions, such as:

- Machine Drive
- All-Wheel Steer (if equipped)
- Hydraulic Tread Adjustment (if equipped)
- Attachment Operation
- Spray Systems
- Reversible Fan
- Rear-View Camera
- Exterior Lighting
- Engine/Machine Diagnostics

### Date and Time

#### To Adjust Date and Time

- Press either the Day/Time or the Date (located along the top left and right-hand side of each display page) to navigate to the "Date/Time" screen.

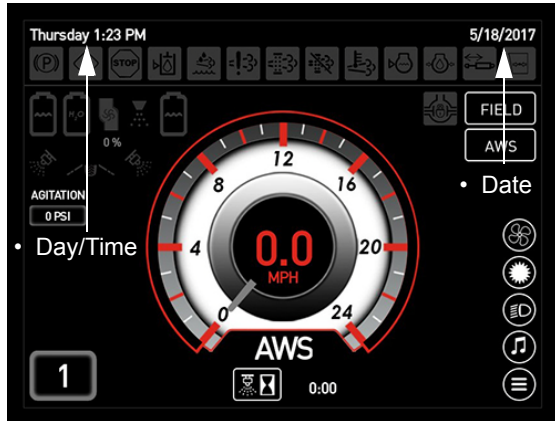

**Date and Time**

(Located along the top left and right-hand side of each display page)

- On the “Date/Time” screen, press any cell in the Date row (to change date), or any cell in the Time row (to change time).

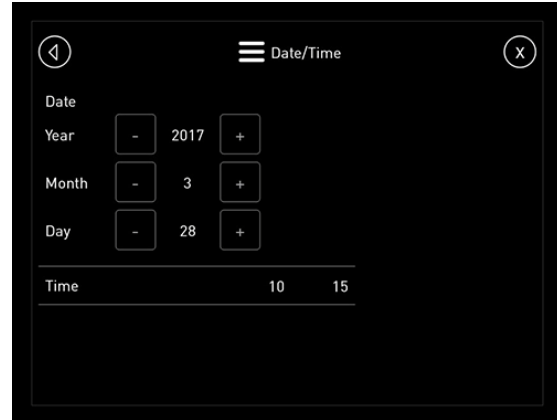

- Press the Back or Exit Button when finished.

*NOTE: The date and time may also be modified through the “Adjustments” screen (Main Menu>Adjustments>Adjust Time).*

### Drive State

The drive state of the machine is displayed on the Home Page - Road and Field Mode.

- Press the Field/Road Button (located on the Home Page) to toggle between the two drive states.

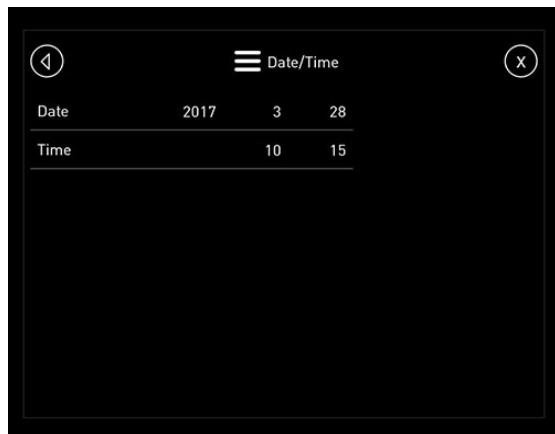

**Date/Time Screen**

- Press the “+” or “-” Button(s) to adjust Date or Time accordingly.

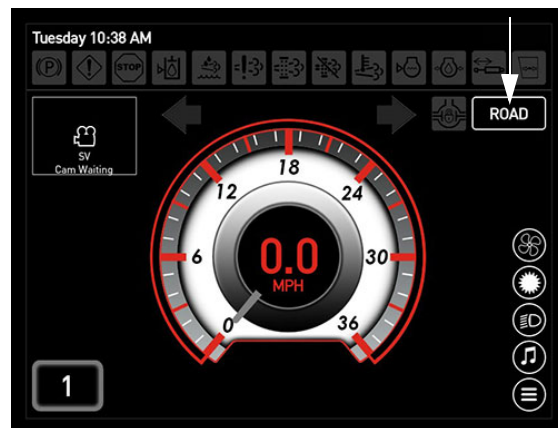

**Field/Road Button  
(Home Page - Road Mode)**

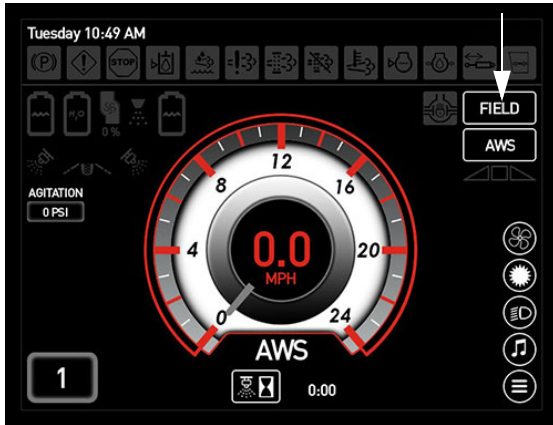

Field/Road Button  
(Home Page - Field Mode)

*NOTE: The drive state of the machine cannot be changed unless the Hydrostatic Drive Control Handle is in the NEUTRAL position (and machine speed is less than 0.5 mph/ 0.8 km/h).*

The machine is featured with three (3) drive states: Road Mode, Field Mode, and Drive Fault. The drive state helps the machine determine what kind of work it is meant to do - field work or transport work.

**Road Mode**

In Road Mode, the machine is limited on what functions can be operated. Road Mode is used for transporting the machine and therefore, will allow the machine to reach maximum speed.

*NOTE: Engine speed in Road Mode can range from 850 to 2500 RPM.*

**Field Mode**

In Field Mode, the machine is allowed function of the spray booms and All-Wheel Steer (if equipped).

*NOTE: Machine speed is limited and is unable to reach maximum speed while in Field Mode.*

**Drive Fault**

The third drive state, “Drive Fault” may appear as a warning message on the display page if there is a system malfunction that affects the machine’s ability to function

properly. This message will tell you why the error occurred and what, if anything, should be done to correct the issue. As a result, machine performance will be limited.

*NOTE: When a Drive Fault is present, the Field/Road Button (located on the Home Page) will be replaced by “FAULT”. Settings will be in Field Mode.*

**Speedometer**

The speed in which the machine travels is displayed on the Home Page - Road and Field Mode. The unit of measure can be viewed as miles per hour (mph) or kilometers per hour (km/h).

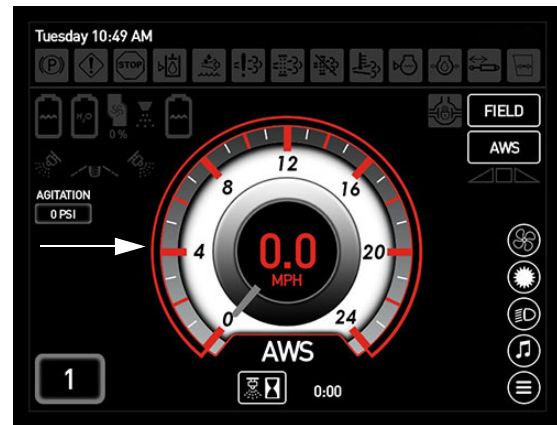

Speedometer  
(Located on the Home Page - Road and Field Mode)

*NOTE: Press the center of the Speedometer to navigate to the “Speed Settings” screen.*

*NOTE: See “Main Menu” for information on changing the unit of measure.*

**Speed Range**

Your machine is featured with three speed ranges - Speed Range 1, Speed Range 2, and Speed Range 3. The Speed Range selected is displayed on the Home Page - Road and Field Mode.

See “Speed Settings” in the Main Menu section for further information.

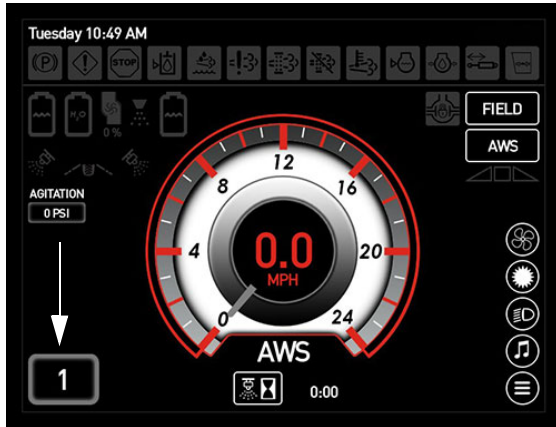

Speed Range  
(Located on the Home Page  
- Road and Field Mode)

### Warning Indicator Lamps

To alert the operator of certain operations or when a machine system requires attention, various warning indicators are located on the top of each display page and illuminate to inform you of a specific situation.

- Parking Brake ON
- Check Engine/Alert Lamp (for non-engine related faults)
- Stop Engine/Stop Machine (for severe fault)
- Low Hydraulic Oil Level
- Low Diesel Exhaust Fluid (DEF) (Final Tier 4 Engines)
- Engine Emissions System Failure/Malfunction
- Exhaust System Cleaning (Manual Regen)
- Engine Cleaning Stop (Inhibit Regen)
- High Exhaust Temperature (HEST)
- Low Engine Coolant Level
- Low Engine Oil Pressure
- Glow Plugs Active/Wait to Start
- Boom Charge
- Insufficient Cab Air Pressure



## Display Buttons



- Home Button



- Main Menu Button



- Reset Button  
*NOTE: The Reset Button resets setting back to default value.*



- Information/Help Button



- Back Button



- Accept Button



- Exit Button



- Phone Button (Answer)



- Phone Button (Reject/Hang Up)  
*NOTE: If a phone is connected to the radio via bluetooth and a call is received, two (2) Phone Buttons will appear on the Home Page and the Audio Page (if "Show Shortcuts" is enabled). Press the top button to ANSWER the phone call. Press the bottom button to REJECT/HANG UP the phone call.*

pressing the Sound Muted Button (*Main Menu Page>Preferences*). However, the corresponding warning indicator lamp (located along the top of each display page) will remain illuminated until the issue has been corrected.

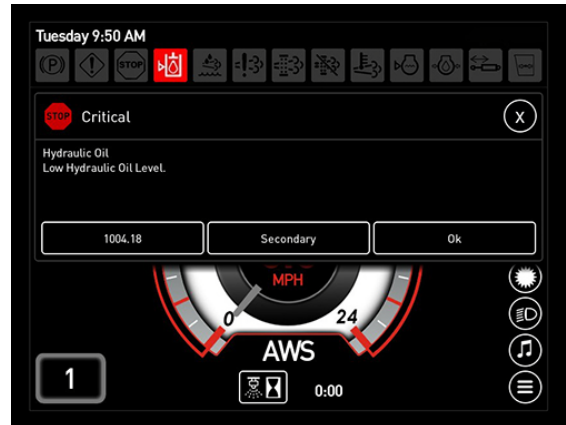

Warning Message

*NOTE: The Sound Button will reset to the ON (enabled) position each time the ignition key is cycled.*

## Rear-View Camera

Your machine is equipped with a Rear-View Camera for your safety and convenience when operating the machine in reverse and is integrated into the rear hood.

- Press the Camera Button (located on the Home Page - Road Mode) to navigate to the "Rear-View Camera" screen.

*NOTE: You may also navigate to the "Rear-View Camera" screen through the Main Menu Page.*

## Warning Messages/Alarm

When a system requires attention, a warning message will appear on any given display page telling you what the error is and what should be done to correct it. The warning message will be accompanied by a warning alarm.

The warning message may be cleared by pressing OK to acknowledge the message and the warning alarm may be silenced by

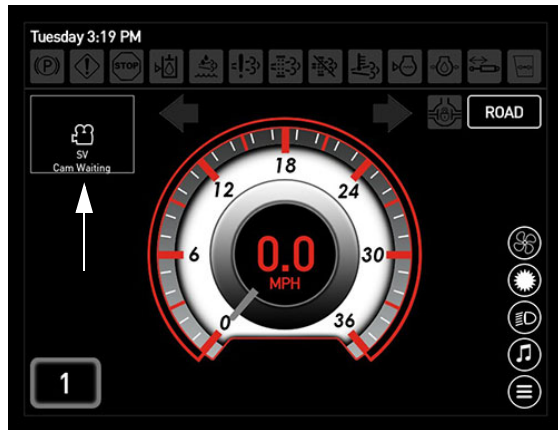

**Camera Button**  
(Located on the Home Page - Road Mode)

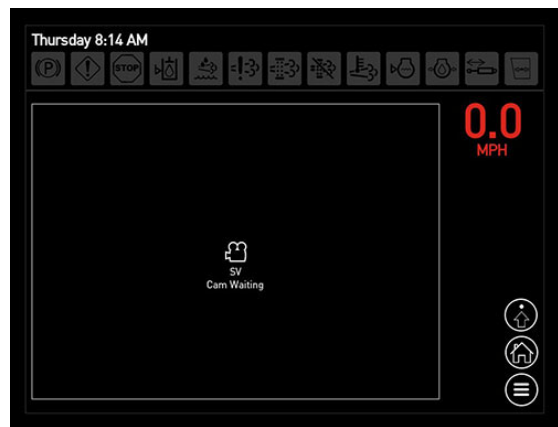

**Rear-View Camera Screen**

The operator may turn the Rear-View Camera on or off in reverse mode, as well as install multiple cameras on the machine. Refer to “Rear-View Camera” in the Main Menu section for further information.

## Spray System Indicators

- Main Tank Indicator (Left)
- Rinse Tank Indicator
- Solution Pump Indicator
- Master Spray Indicator

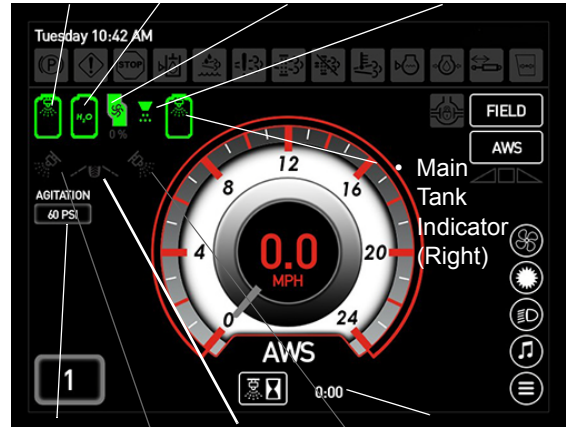

- Agitation Valve Pressure Indicator
- Rear Nozzle Indicator
- Spray Time Indicator
- Left Fence Row Indicator
- Right Fence Row Indicator

**Spray System Indicators**  
(Located on the Home Page - Field Mode)

## Main Tank Indicators (Left/Right)

When the Tank Rinse Switch (located on the side console) is depressed, the corresponding Main Tank Indicator will illuminate.

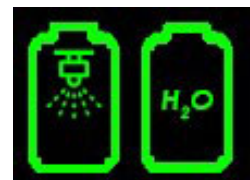

Drawing From Rinse Tank and Rinsing Solution Tank

## Rinse Tank Indicator

The Tank Valve Selector Switches (located on the side console) allow the operator to pull from either the main tank(s) or the rinse tank. The Rinse Tank Indicator (located on the Home Page - Field Mode) will illuminate to display current status.



Drawing From  
Main Tank

Drawing From  
Rinse Tank

### Solution Pump Indicator

When the Solution Pump Switch (located on the side console) is depressed, a Solution Pump Indicator (located on the Home Page - Field Mode) will illuminate.

*NOTE: When the Solution Pump Switch and the Manual (MAN) Rate Control Switch (located on the side console) are both enabled, the pump command is displayed below the Solution Pump Indicator. Press the “+” or “-” Pump Speed/Rate Switch (located on the side console) to increase or decrease solution pump command.*

### Master Spray Indicator

When the Master Spray Switch (located on the Hydrostatic Drive Control Handle) has been activated, a Master Spray Indicator (located on the Home Page - Field Mode) will illuminate.

### Fence Row/Rear Nozzle Indicators

When the left/right Fence Row Switch(es) or the Rear Nozzle Switch (located on the side console spray section keypad) are activated, the corresponding left/right Fence Row or Rear Nozzle Indicators (located on the Home Page - Field Mode) will illuminate.

*NOTE: The rear track nozzle is only activated if the Rear Nozzle Switch is depressed and the center section is ON.*

### Agitation Valve Pressure Indicator

The Agitation Valve Switch (located on the side console) controls the rate of flow through the Agitation System. Agitation pressure is displayed on the Home Page - Field Mode.

### Spray Time Indicator

The current amount of spray application time is displayed on the bottom of the Home Page - Field Mode.

### To Reset Spray Timer

- Press the Reset Spray Button (located next to the Spray Time Indicator on the Home Page - Field Mode).

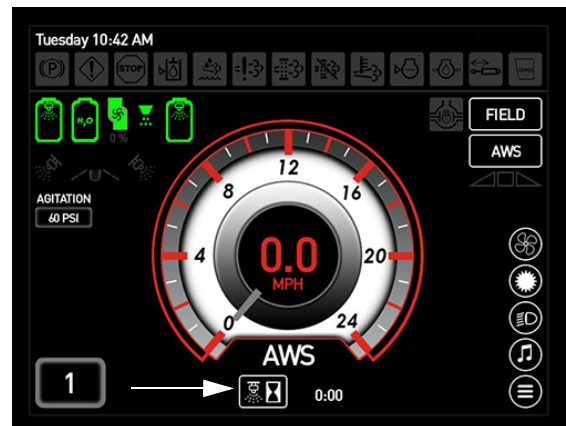

Reset Spray Button  
(Located on the Home Page - Field Mode)

*NOTE: A “Reset Spray Timer Confirmation” message will appear. Press OK to reset total spray time.*

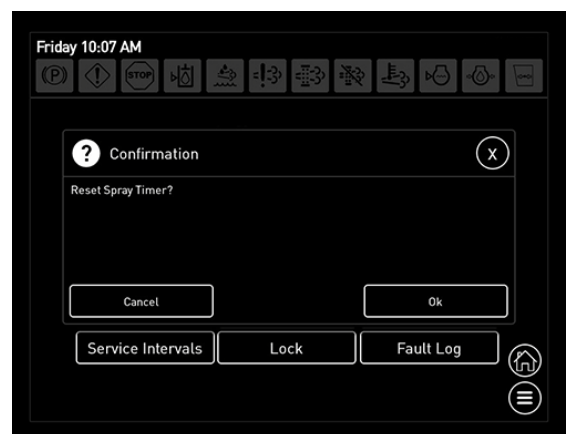

Reset Spray Time Confirmation

### All-Wheel Steer (AWS)

#### -If Equipped

The AWS Button is located on the Home Page - Field Mode. Enable AWS by pressing the button in the ON (illuminated) position.

An AWS indicator (located below the speedometer) will illuminate when AWS is activated (requiring all conditions to be met).

- AWS Button

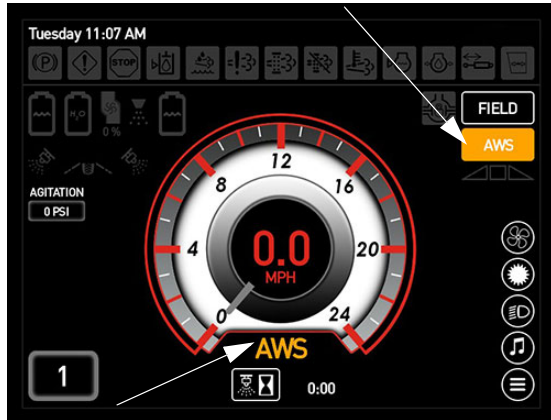

- AWS Indicator

All conditions must be met before AWS will activate. First, the machine must be in Field Mode, and second, machine speed must be less than AWS Shutoff Speed. If these conditions are not met, the AWS Button will remain ON, but the AWS indicator will turn OFF, and the machine will be operating in conventional steering mode. When conditions are met again, AWS will automatically activate and the AWS indicator will illuminate.

*NOTE: The machine will automatically determine if the proper conditions have been met and change the status of the drive functions.*

### AWS Shutoff Speed

AWS Shutoff Speed can be changed through the Speed Settings on the Main Menu Page. In addition, the “Speed Settings” screen may also be accessed directly by pressing the center of the speedometer.

See “Speed Settings” information in the Main Menu section for further information.

*NOTE: AWS Shutoff Speed default is set to 10 mph (16 km/h).*

*NOTE: AWS Shutoff Speed may only be adjusted in Speed Range 1 or 2.*

Refer to “All-Wheel Steer” provided in the *Engine and Drive Systems Section* elsewhere in this manual for complete operating instructions and safety precautions.

### Main Menu

The Main Menu Page features various machine settings, such as:

- Home
  - Exterior Lighting
  - Hydraulic Tread Width Adjustment (if equipped)
  - Engine Diagnostics
  - Attachment
  - Speed Settings
  - Brightness (Display, Side Console, Machine Gauges)
  - End Row Management
  - Reversible Fan
  - Rear-View Camera
  - Audio (Radio/MP3/Bluetooth)
  - Machine Adjustments
  - Display Preferences
  - Air Purge (if equipped)
  - Solution System
  - System Faults
  - Measure
- Press the Main Menu Button (located on the Home Page - Road and Field Mode) to navigate to the Main Menu Page.

*NOTE: You may also press the Main Menu Button (located on the bottom right-hand corner of each display page) to navigate directly to the Main Menu Page.*

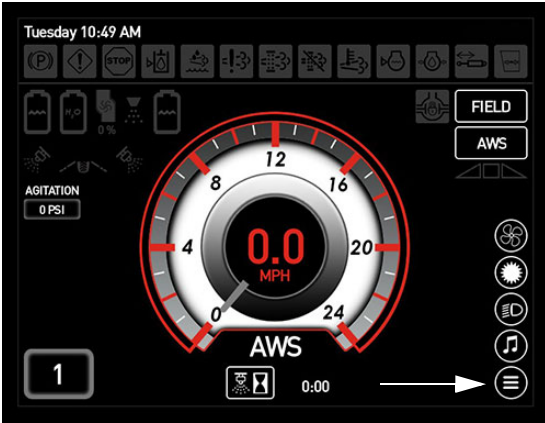

**Main Menu Button**  
(Located on the Home Page  
- Road and Field Mode)



**Home Button**  
(Located on the Main Menu Page)

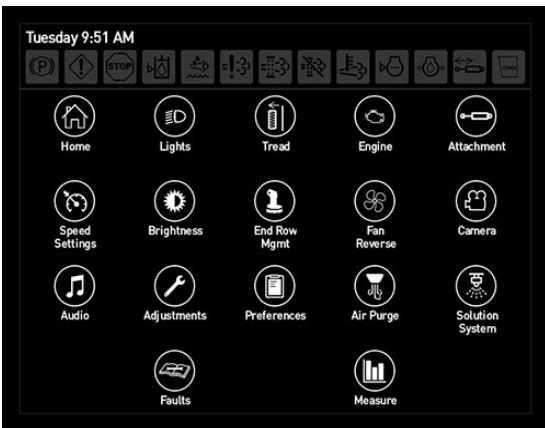

**Main Menu**

### Exterior Lighting

(Field Lights, Work/Night Spray Lights, and Attachment Lights)

- Press the Lights Button to navigate to the “Exterior Lighting” screen.



**Lights Button**  
(Located on the Main Menu Page)

### Home

- Press the Home Button to navigate back to the Home Page - Road/Field Mode.

*NOTE: You may also press the Home Button (located on the bottom right-hand corner of each display page) at any time to navigate directly to the Home Page.*



Exterior Lighting Screen

*NOTE: The light buttons will illuminate when in the ON position.*

### Field Lights

The Field Lights are located on the front of the cab.

- Press the Field Lights Button(s) (FLD1 and/or FLD2) to turn Field Lights ON. Press button(s) again to turn Field Lights OFF.

*NOTE: Turn the Field Lights OFF before entering a public roadway.*

*NOTE: The ignition key must be in the ON position to operate the Field Lights.*

### Work/Night Spray Lights

The Work/Night Spray Lights are located on the underside of each boom wing and on each side of the main boom fold section.

- Press the Work Lights Button (WRK) to turn Work/Night Spray Lights ON. Press button again to turn Work/Night Spray Lights OFF.

*NOTE: Turn the Work/Night Spray Lights OFF before entering a public roadway.*

*NOTE: The ignition key must be in the ON position to operate the Work/Night Spray Lights.*

### Attachment Lights

#### -If Equipped

The Attachment Lights are located on the front of transom.

- Press the Attachment Lights Button (ATCH) to turn Attachment Lights ON. Press button again to turn Attachment Lights OFF.

*NOTE: Turn the Attachment Lights OFF before entering a public roadway.*

*NOTE: The ignition key must be in the ON position to operate the Attachment Lights.*

### All Lights

- Press the All Lights Button (ALL) to turn all exterior lights ON (Field, Work/Night Spray, and Attachment - if equipped). Press button again to turn all lights OFF.

*NOTE: The ignition key must be in the ON position to operate the Exterior Lights.*

### Lights Settings

The “Lights Settings” screen is used in conjunction with the lights shortcut action on the Home Page - Road and Field Mode. The operator can choose which lights to have on for each setting, which will allow toggling back and forth between the two settings when the Lights Shortcut Button on the Home Page is pressed.

*NOTE: The Show Shortcuts option must be enabled (Main Menu>Preferences) to be able to toggle between the two settings from the Home Page.*

- On the “Exterior Lighting” screen, press the Settings Button to navigate to the “Lights Settings” screen.



**Settings Button**  
(Located on the Exterior Lighting Screen)

- On the “Lights Settings” screen, press the cell (next to Lights Shortcut Action) and select ALL LIGHTS or TOGGLE 2 SETTINGS.

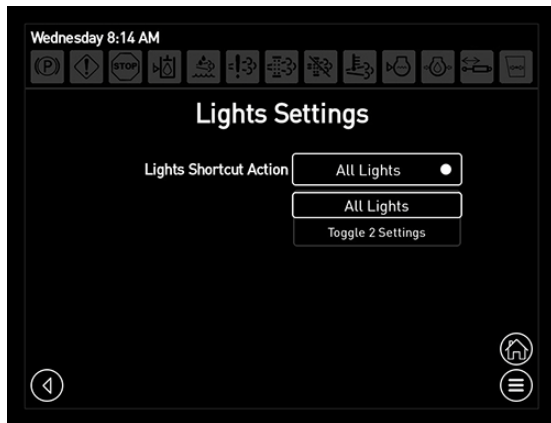

**Lights Settings Screen**

### All Lights

When ALL LIGHTS is selected, Field Lights, Work/Night Spray Lights, and Attachment Lights - *if equipped* will all activate/deactivate when the Lights Shortcut Button on the Home Page is pressed.

### Toggle 2 Settings

When TOGGLE 2 SETTINGS is selected, only the desired lights pre-selected for each setting will activate/deactivate when the Lights Shortcut Button is pressed.

- On the “Lights Settings” screen, press the cell next to Lights Shortcut Action and select TOGGLE 2 SETTINGS.

- Select desired lights that you wish to activate/deactivate for each setting.

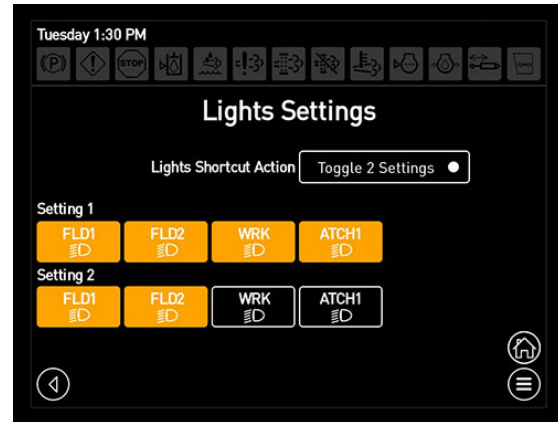

**Lights Settings Screen - Toggle 2 Settings**

- You may now toggle between the two lights settings by pressing the Lights Shortcut Button on the Home Page.

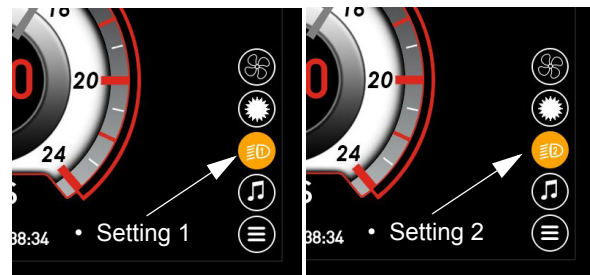

**Lights Shortcut Button - Setting 1/2**  
(Located on the Home Page  
- Road and Field Mode)

*NOTE: If toggling between the two lights settings, it is necessary to navigate to the “Exterior Lighting” screen and manually turn all lights OFF prior.*

*NOTE: Press and hold the Lights Shortcut Button to navigate directly to the “Exterior Lighting” screen (for whichever setting is currently selected on the Home Page).*

## Hydraulic Tread Width Adjustment

### -If Equipped

Hydraulic Tread Width can be individually adjusted by pressing and holding the corresponding Tread Width Adjustment Button (located on the “Tread Width

Adjustments” screen). If desired, multiple tread widths may be adjusted simultaneously.

- Press the Tread Button to navigate to the “Tread Width Adjustments” screen.



**Tread Button**  
(Located on the Main Menu Page)

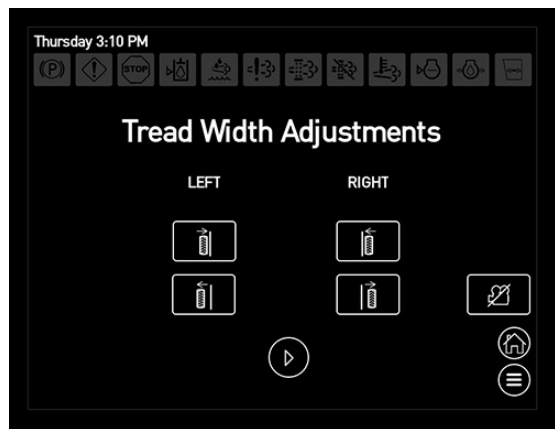

**Tread Width Adjustments Screen**

- If desired, press the Arrow Button (located on the “Tread Width Adjustments” screen) to navigate to the “Multiple Tread” screen).

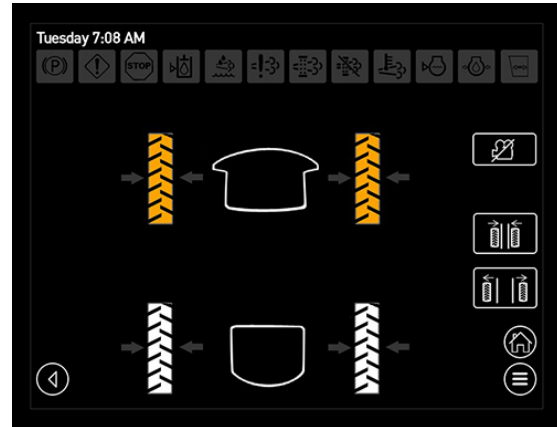

Refer to “Tread Adjustment - Hydraulic” provided in the *Hydraulic Systems Section* elsewhere in this manual for complete operating instructions and safety precautions.

### Engine Diagnostics

- Press the Engine Button to navigate to the “Engine Diagnostics” screen.



**Engine Button**  
(Located on the Main Menu Page)



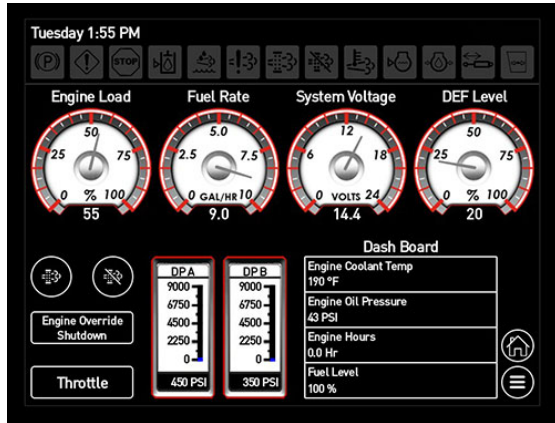

Engine Diagnostics Screen

### System Gauges

#### (Engine Load, Fuel Rate, System Voltage, and DEF Level)

Electronic System Gauges for Engine Load, Fuel Rate (gallons/liters per hour), System Voltage, and DEF Level are located on the “Engine Diagnostics” screen. Digital display indicators are located beneath each gauge.

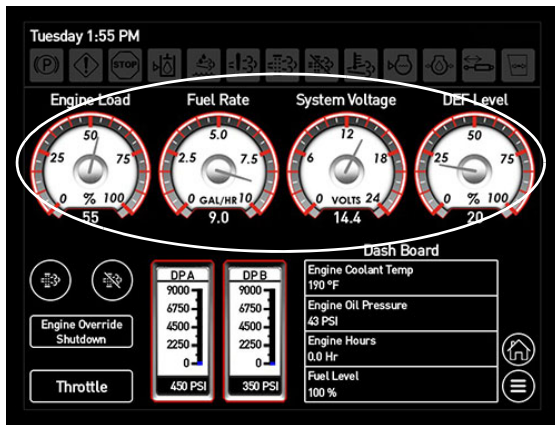

System Gauges

(Located on the Engine Diagnostics Screen)

*NOTE: When battery voltage depletes to 11.7 volts and below, a warning message will appear alerting you of low battery voltage. The low voltage warning will disappear when voltage is greater than 12.5 volts.*

### System Diagnostics (Dash Board)

System Diagnostics may be viewed on the “Engine Diagnostics” screen. Such items include:

- Engine Coolant Temperature
- Engine Oil Pressure
- Engine Hours
- Fuel Level (percentage of full)

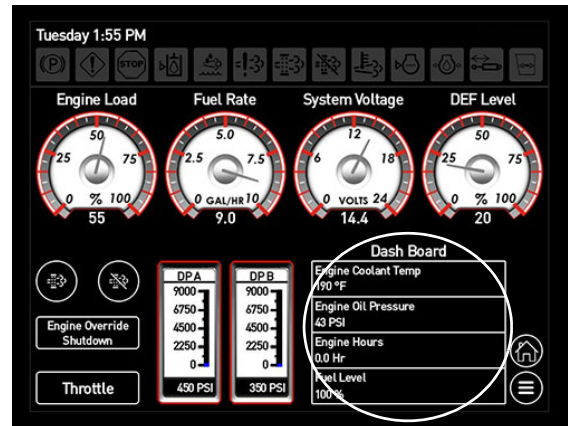

System Diagnostics

(Located on the Engine Diagnostics Screen)

### Engine Coolant Temperature

The Engine Coolant Temperature is displayed on the “Engine Diagnostics” screen. If the engine coolant temperature reaches a level that is too high (greater than 220° F.), a warning message will appear and a red warning indicator lamp will illuminate along the top of any given display page. In addition, a warning alarm will sound.

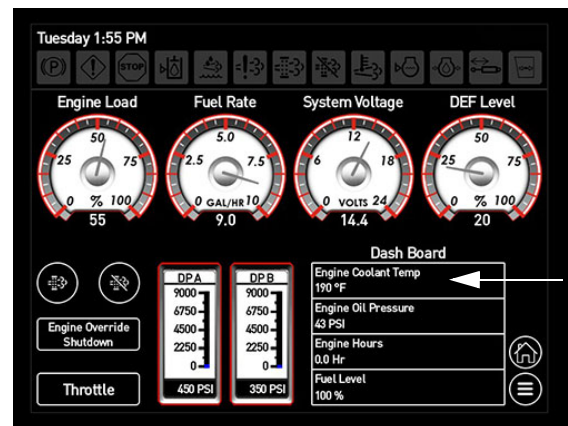

Engine Coolant Temperature

(Located on the Engine Diagnostics Screen)

*NOTE: The warning alarm may be silenced by pressing the Sound Muted Button (Main Menu Page>Preferences).*

If the engine temperature continues to rise after the initial warning message, a second warning message will appear shortly before the machine begins to go into protective mode, alerting you that the engine coolant temperature is too high and the engine will begin to de-rate. Press OK to acknowledge.

If this warning message appears, immediately reduce the engine speed and allow engine to idle. This will allow the cooling system to cool the engine down and prevent possible damage. Contact your local John Deere dealer if troubleshooting assistance is needed.

*NOTE: When this warning message appears, the machine may be severely limited in engine and hydraulic functions (to prevent possible damage to those systems).*

### DP-A/DP-B Gauges

The DP-A and DP-B Gauges (located on the “Engine Diagnostics” screen) displays current drive pump pressure.

- **DP-A** (Drive Pump, Port A) - High in forward acceleration or reverse deceleration.
- **DP-B** (Drive Pump, Port B) - High in forward deceleration or reverse acceleration.

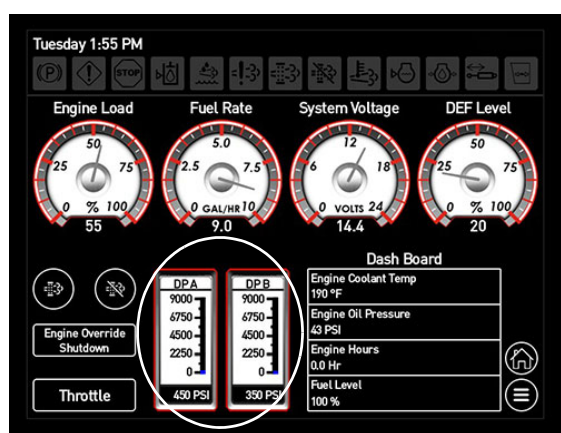

DP-A/DP-B Gauges  
(Located on the Engine Diagnostics Screen)

### Engine Override (Final Tier 4 engines)

**NOTICE**

The Engine Override feature is not intended as means of avoiding an engine shutdown for an extended period of time.

The Engine Override Shutdown Button (located on the “Engine Diagnostics” screen) allows the operator to continue running the engine for a calibrated time period in order to move the vehicle to a safe stopping location.

#### To Temporarily Avoid Engine Shutdown

- Press and hold the Engine Override Shutdown Button (located on the “Engine Diagnostics” screen) momentarily.

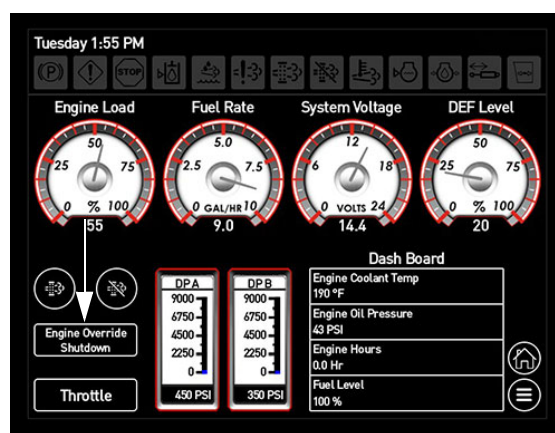

Engine Override Shutdown Button  
(Located on the Engine Diagnostics Screen)

Refer to the engine manufacturer’s operation manual for further information.

### Engine Regeneration

#### (Manual Regen/Inhibit Regen)

The Manual/Inhibit Regen Buttons (located on the “Engine Diagnostics” screen) allow the operator to perform a manual engine exhaust system cleaning.

Refer to the “Engine Aftertreatment - Final Tier 4” information provided in the *Engine and Drive Systems Section* elsewhere in this manual for complete operating instructions and safety precautions.

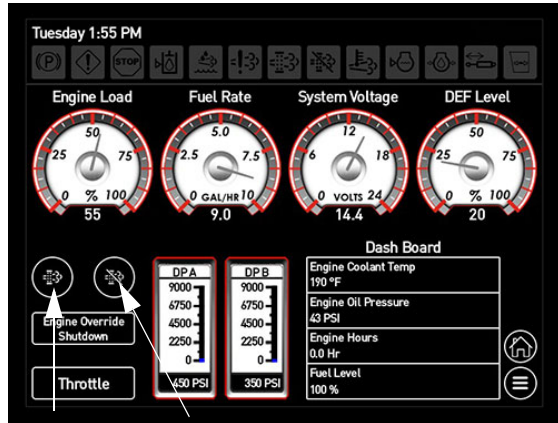

- Manual Regen
- Inhibit Regen

Manual/Inhibit Regen Buttons  
(Located on the Engine Diagnostics Screen)

## Engine Throttle

### Throttle Control Slope

Determines how fast engine speed increases when the Throttle Switch (located near the Hydrostatic Drive Control Handle) is pressed in the UP (“rabbit icon”) position.

*NOTE: Values are set as a percentage per second.*

*NOTE: If Throttle Control Slope is set at 25 percent per second and Throttle Max is set at 100 percent, Throttle Up Ramp should be at least four (4) seconds to achieve 100 percent throttle when operating the Throttle Switch.*

### Throttle Up Ramp

Amount of time engine speed will increase or decrease when the Throttle Switch (located near the Hydrostatic Drive Control Handle) is pressed up or down.

### Throttle Max

Maximum percentage that engine speed will achieve (e.g. If Throttle Max is set at 100 percent, throttle control will set engine speed

between 850 and 2500 RPM. If Throttle Max is set at 0 percent, maximum engine speed will be 850 RPM).

*NOTE: Pressing the Throttle Switch (located near the Hydrostatic Drive Control Handle) in the UP (“rabbit icon”) position will not increase engine speed when Throttle Max is set at 0 percent.*

### To Change Throttle Setting Values:

- Press the Throttle Button (located on the “Engine Diagnostics” screen).

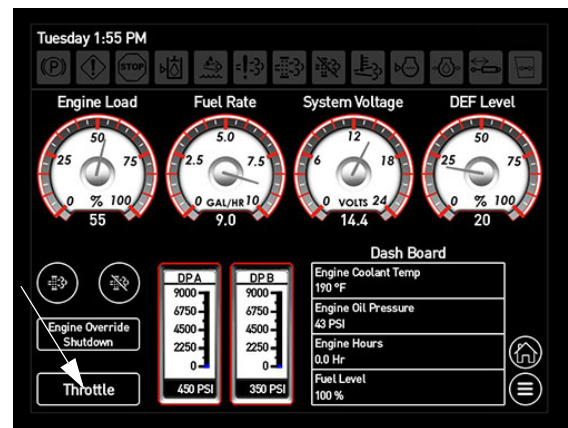

Throttle Button  
(Located on the Engine Diagnostics Screen)

- On the “Throttle Settings” screen, use the slide bar to adjust desired throttle value.

*NOTE: Slide right to increase value, or left to decrease value.*

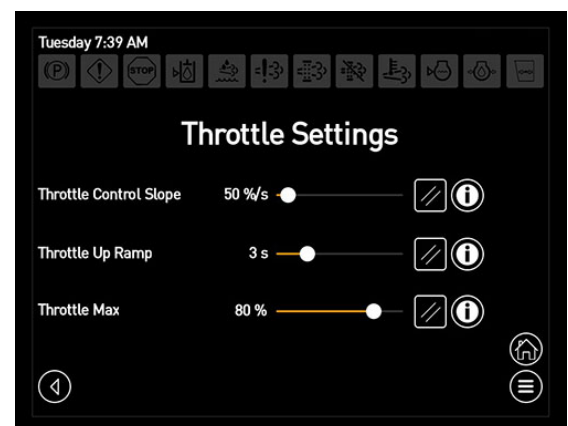

Throttle Settings Screen

- Press the Back Button to return to the previous screen.

Refer to “Hydrostatic Drive” provided in the *Engine and Drive Systems Section* elsewhere in this manual for further information.

## Attachment

### Spray Booms

Spray Boom settings are controlled through the Machine Display, which include:

- Manual/Auto Mode
  - Fold Extensions
  - Main Lift Speed
  - Level Speed
  - Lifted Height
  - Spray Height
  - Attachment to Ground
- Press the Attachment Button to navigate to the “Boom State” screen.

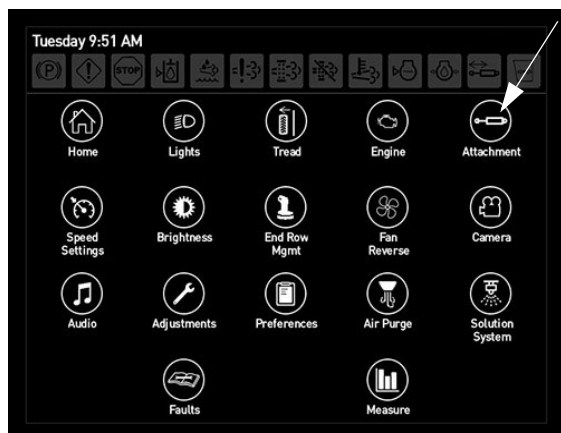

Attachment Button  
(Located on the Main Menu Page)

The “Boom State” screen allows the operator to change various boom adjustments to best suit your operating needs.

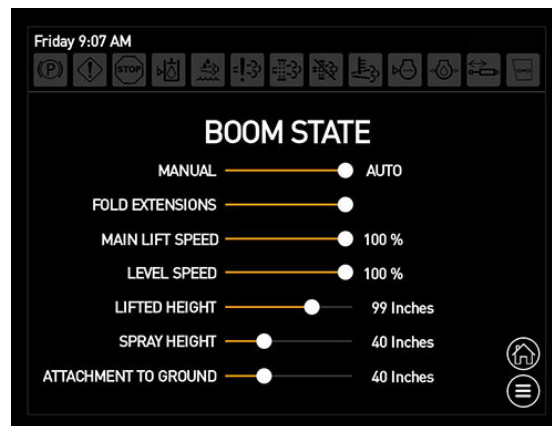

Boom State Screen

### Auto/Manual Mode

**Auto Mode** allows the operator to fold/unfold the booms by operating the Boom Extension Switches (located on the side console). **Manual Mode** allows the operator to fold/unfold the booms manually operating the corresponding boom switches on the Hydrostatic Drive Control Handle and the side console.

### Fold Extensions

Fold Extensions must be activated to enable Auto Fold operation of the outer boom sections.

*NOTE: When Fold Extensions are disabled, the main boom will fold/unfold, but the outer boom extensions will not.*

### Main Lift Speed

Main Lift Speed is the speed in which the transom travels up and down.

*NOTE: The higher the percentage, the faster the main lift will move. The lower the percentage, the slower the main lift will move.*

### Level Speed

Level Speed is the speed in which the boom wings travel up and down.

### Lifted Height\*

Lifted Height is the raised boom height position measured from nozzle to ground.

**Spray Height\***

Spray Height is the height that the operator would like the boom to be when spraying (nozzle-to-ground distance).

**Attachment to Ground\***

Attachment to Ground is the height from the spray nozzle-to-ground with the boom in its lowest position.

**\* Return to Height Settings**

*NOTE: Attachment to Ground is measured by the operator to better dial in the system if the tires are changed on the machine.*

In the event that the boom breaks away or the machine is turned off with the boom in the spray position, a warning message will appear stating that the boom is in the spray position, but not charged. Press OK to acknowledge and recharge by pressing the corresponding Left or Right-Hand Boom Switch (located on the Hydrostatic Drive Control Handle) in the OUT position.

In addition to the boom charge warning message, a boom charge indicator will illuminate along the top of any given display page.

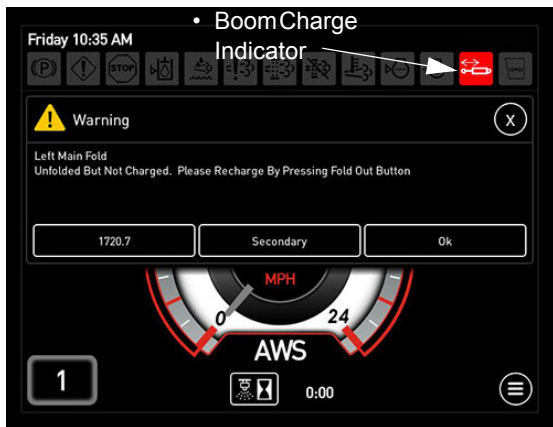

Boom Charge Warning

Refer to “Spray Booms” provided in the *Spray Systems Section* elsewhere in this manual for further information.

**Speed Settings**

**(Speed Ranges)**

Your machine is featured with three speed ranges - Speed Range 1, Speed Range 2, and Speed Range 3. The Speed Range selected is displayed on the Home Page - Road and Field Mode.

*NOTE: Speed Range 3 is available in Road Mode only. This range is always set to maximum speed and is non-adjustable.*

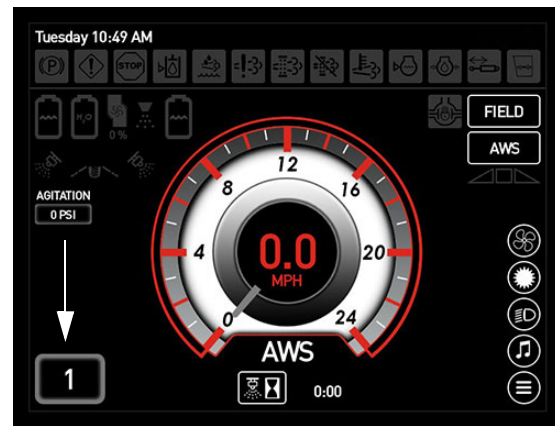

Speed Range  
(Located on the Home Page  
- Road and Field Mode)

Refer to “Hydrostatic Drive” provided in the *Engine and Drive Systems Section* elsewhere in this manual for further information on the different speed ranges.

**To Change Speed Range**

*NOTE: The Hydrostatic Drive Control Handle must be in the NEUTRAL position before changing Speed Range settings.*

- Press the Speed Settings Button to navigate to the “Speed Settings” screen.

*NOTE: You may also navigate to the “Speed Settings” screen by pressing the center of the speedometer on the Home Page.*

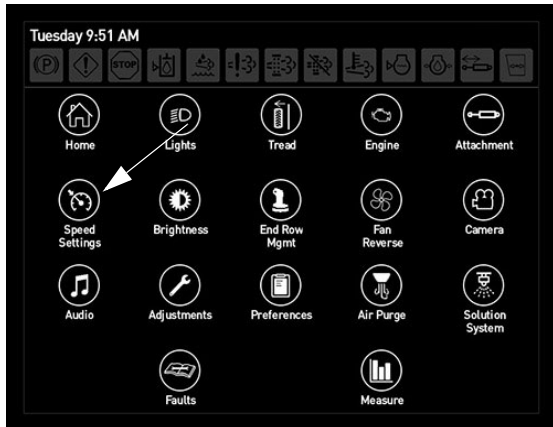

**Speed Settings Button**  
(Located on the Main Menu Page)

- On the “Speed Settings” screen, press the arrow button(s) (next to desired speed range) until desired speed is obtained.

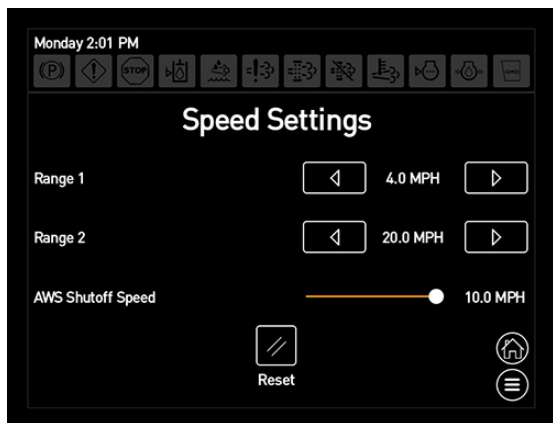

**Speed Settings Screen**

**AWS Shutoff Speed**

- Press the Speed Settings Button to navigate to the “Speed Settings” screen.

*NOTE: You may also navigate to the “Speed Settings” screen by pressing the center of the speedometer on the Home Page.*

- On the “Speed Settings” screen, use the slide bar to adjust to desired speed.

*NOTE: Slide right to increase speed, or left to decrease speed.*

**Brightness Adjustment**

(Day Time/Night Time)

**To Adjust the Display, Side Console Switches, and Gauge Post Lighting**

- Press the Brightness Button to navigate to the “Brightness” screen.

*NOTE: You may also navigate directly to the “Brightness” screen by pressing and holding the Brightness Shortcut Button on the Home Page.*



**Brightness Button**  
(Located on the Main Menu Page)

- On the “Brightness” screen, press desired “Day Time” or “Night Time” Button.
- Use the slide bar to adjust desired brightness level (display, console, and/or side console switches).

*NOTE: Slide right to increase brightness level, or left to decrease brightness level.*

*NOTE: The side console switches and gauge post do not have adjustable brightness settings. Slide the slide bar to the right to turn switch lighting ON, or to the left to turn switch lighting OFF.*

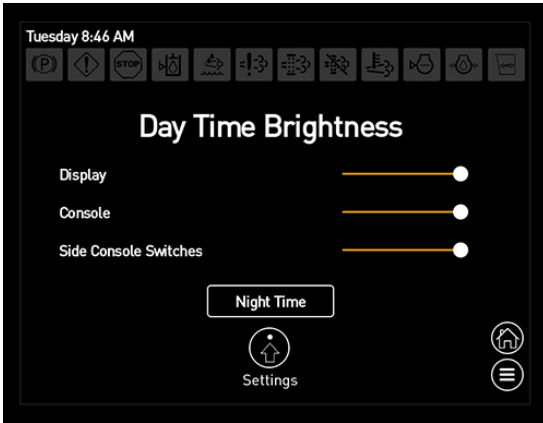

Brightness Screen

**To Set Automatic Night Time/Day Time Transition Brightness**

*NOTE: Brightness levels must be manually set (as previously described) before setting automatic transition brightness.*

- On the “Brightness” screen, press the Settings Button.
- On the “Transition Settings” screen, slide the ENABLE TIME TRANSITION slide bar to the right to enable.

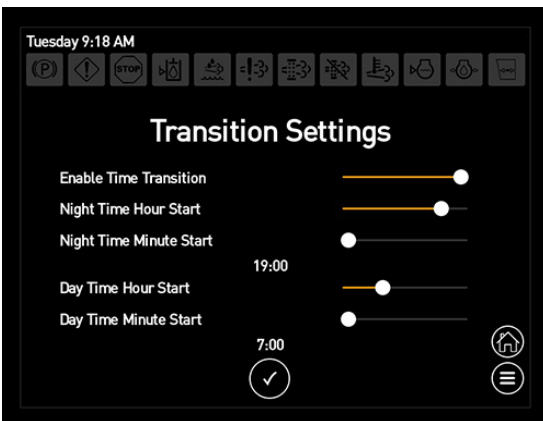

Transition Settings Screen

- Use the slide bar to adjust desired value (time of day that brightness level will activate) for either Night Time or Day Time Hour/Minute Start.

*NOTE: Slide right to increase the amount of hours/minutes, or left to decrease the amount of hours/minutes.*

- Press the Accept Button when finished.

**End Row Management**

The End Row Management Switch (located on the Hydrostatic Drive Control Handle) may be programmed for use of various functions, including All-Wheel Steer (if equipped), Auto Steer, Master Spray, NORAC® Enable (if equipped), and Return to Height.

*NOTE: End Row Management functions are disabled in Road Mode.*

**To Program the End Row Management Switch**

- Press the End Row Management Button to navigate to the “Select Action to Program” screen.

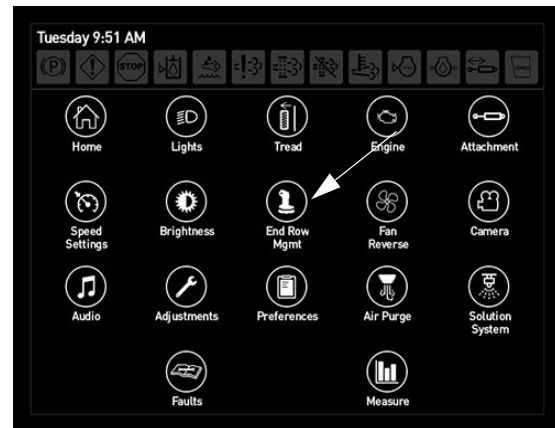

End Row Management Button  
(Located on the Main Menu Page)

- On the “Select Action to Program” screen, select the setting in which you wish to operate the End Row Management Switch (located on the Hydrostatic Drive Control Handle) - “Single Press” or “Press and Hold”.



Select Action to Program Screen

- On the “End Row Management Editor” screen, press the desired function you want to set (AWS - *if equipped*, Auto Steer, Master Spray, NORAC Enable - *if equipped*, or Return to Height).
- Press the “Delayed Time” cell next to the function you selected.
- Press the “+” or “-” Button to adjust to desired value - amount of time (seconds) from when the previous action is activated to when the function is engaged.

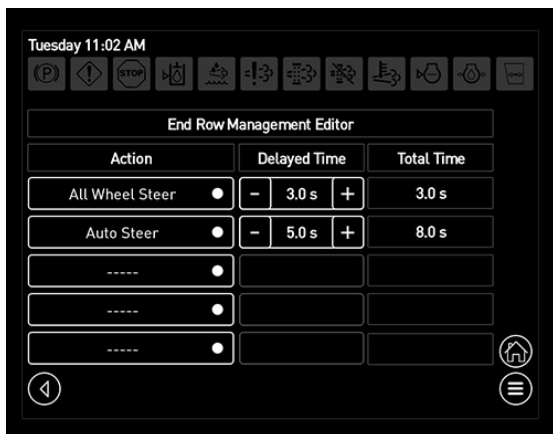

End Row Management Editor Screen

- Press the back arrow when finished.

**Total Time**

Displays the total time from when the End Row Management Switch is pressed until the action is commanded.

*Example:*

	Delayed Time	Total Time	Time from when ERM Button is pressed to engagement
1.	0	0	0
2.	0.5	0.5	0.5
3.	1.0	1.5	1.5
4.	0	1.5	1.5

**Edit End Row Management Settings**

- On the “Select Action to Program” screen, press the Settings Button.
- On the “End Row Management Settings” screen, use the corresponding slide bar to adjust value/setting (next to desired End Row Management setting).
  - *Pause Before Activate (seconds)*
  - *Display When Active (yes or no)*
  - *Enable Single Press (yes or no)*
  - *Enable Press and Hold (yes or no)*

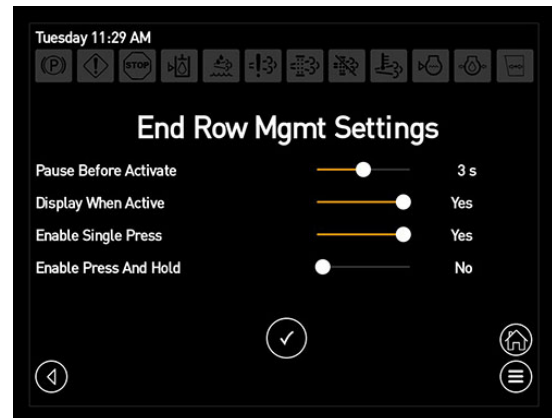

End Row Management Settings Screen

- Press the Accept Button when finished.

**Reversible Fan**

**(Variable Pitch)**

**-If Equipped**

**To Activate the Reversible Fan**

- Press the Fan Reverse Button to navigate to the “Engine Fan Control” screen.



*NOTE: You may also navigate directly to the “Engine Fan Control” screen by pressing and holding the Fan Shortcut Button on the Home Page.*



Fan Reverse Button  
(Located on the Main Menu Page)

- On the “Engine Fan Control” screen, press the Reverse Button to turn the fan ON (reverse).

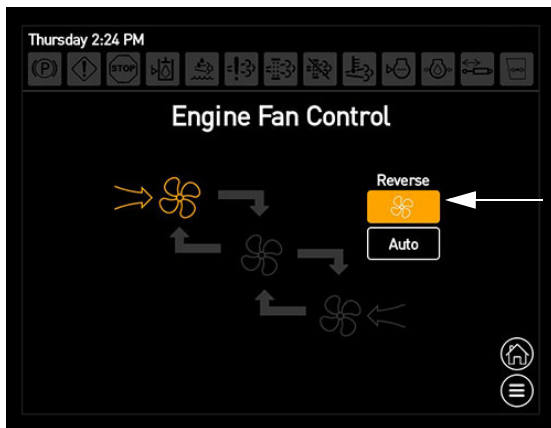

Reverse Button  
(Located on the Engine Fan Control Screen)

*NOTE: During the reverse cycle, the “Engine Fan Control” screen will display the current state of the reversible fan (airflow direction). The fan will automatically return to normal operation when the reverse cycle is complete.*

### Auto Fan Reversing

The Reversible Fan may be operated in Auto mode, which allows the operator to adjust the amount of time between automatic fan reversals.

#### To Enable Auto Fan Reversing

- On the “Engine Fan Control” screen, press the Auto Button.

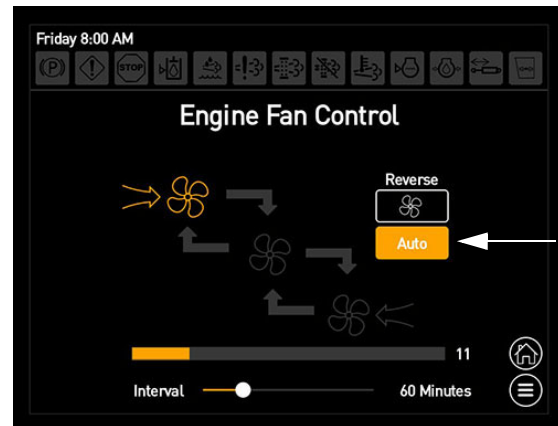

Auto Button  
(Located on the Engine Fan Control Screen)

- Use the slide bar (next to Interval) and adjust to desired value (amount of time between automatic fan reversals).

*NOTE: Slide right to increase time, or left to decrease time.*

*NOTE: Auto Fan Reverse interval range is between 10 and 240 minutes.*

*NOTE: A progress bar is located near the bottom of the screen to display the current number of minutes into the fan reversal process.*

- Once the selected time interval has been reached, the Reverse Button will illuminate and the Auto Fan Reverse process will start over.

Refer to “Reversible Fan - Variable Pitch” provided in the *Hydraulic Systems Section* elsewhere in this manual for further information.

### Camera (Rear-view)

- Press the Camera Button to navigate to the “Rear-view Camera” screen.

*NOTE: You may also navigate to the “Rear-view Camera” screen through the Home Page - Road Mode.*

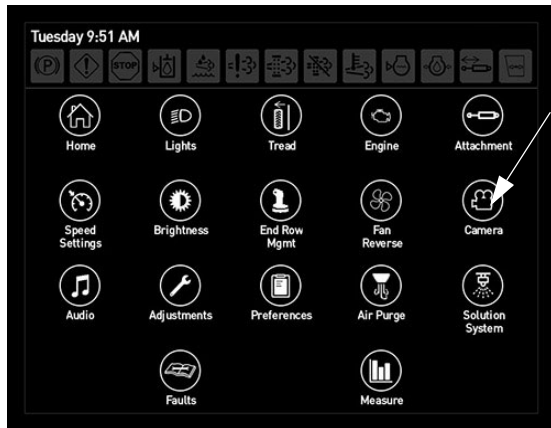

Camera Button  
(Located on the Main Menu Page)

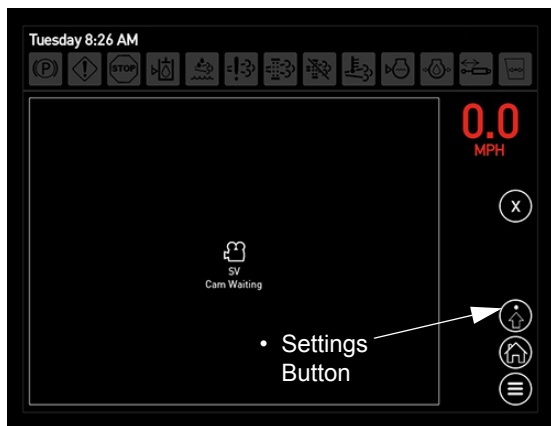

Rear-view Camera Screen

**Rear-view Camera Settings**

**(Rear-view Camera in Reverse/Enable Camera in Road Mode)**

*NOTE: Rear-view Camera in Reverse feature resets to ON after ignition key cycle.*

- On the “Rear-view Camera” screen, press the Settings Button.
- On the “Camera Settings” screen, use the corresponding slide bar to turn the “Rear-view Camera in Reverse” and/or “Enable Camera in Road Mode” option ON (Yes) or OFF (No).

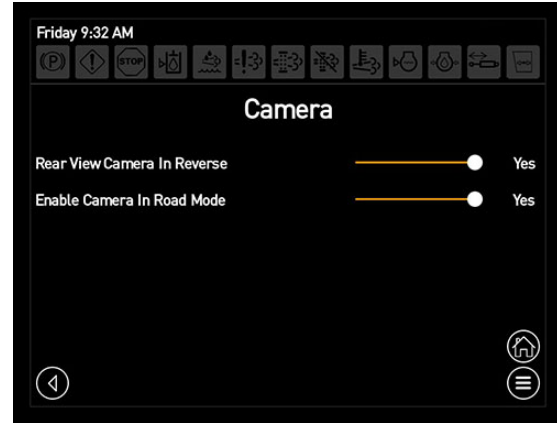

Camera Settings Screen

**Multiple Rear-View Cameras**

The Multiple Rear-View Camera feature allows the operator to install more than one camera on the machine. Press the corresponding camera image to view full screen of that camera.

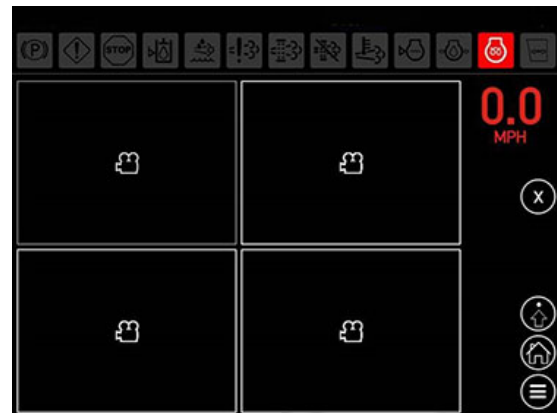

Multiple Rear-View Camera Screen

**Audio**

- Press the Audio Button to navigate to the “Audio” screen.

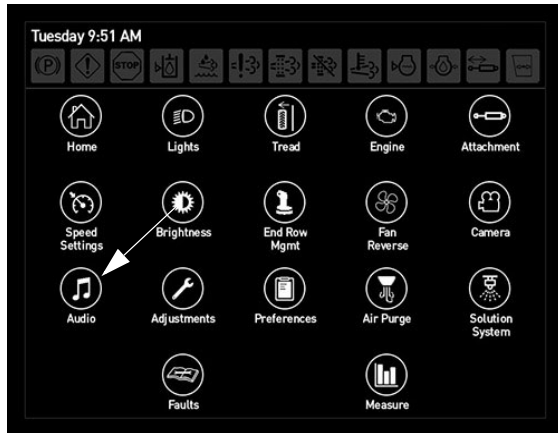

Audio Button  
(Located on the Main Menu Page)

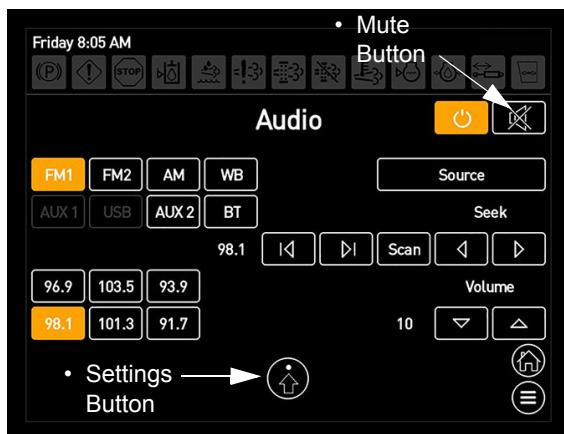

Audio Screen

### Volume Buttons

- Press the Volume Button(s) to the right to increase sound level, or to the left to decrease sound level.

### Mute Button

- Press the Mute Button to silence/mute stereo sound. Press again to resume sound.

### Seek Buttons

- (1) - Press the Seek “Down” Button (left arrow with line) to shuffle to next tunable station.
- (2) - Press the Seek “Down” Button (left arrow) to shuffle one station/channel at a time.
- (3) - Press the Seek “Up” Button (right arrow) to shuffle one station/channel at a time.

- (4) - Press the Seek “Up” Button (right arrow with line) to shuffle to next tunable station.

### Scan Button

- Press the Scan Button to seek the next tunable station, which will then pause on that station momentarily (approximately five seconds) before continuing on to the next station.

*NOTE: Scanning will continue until it makes it back to the starting point, or if the Scan Button is pressed again, one of the other Seek Buttons is pressed, or the source is changed.*

### Power Button

- Press the Power Button to power the radio on. Press again to power the radio off.

*NOTE: The Power Button will illuminate orange when on.*

### Source Buttons

**(AUX1, USB, FM1, FM2, AM, Weatherband, AUX2, Bluetooth)**

- Press the desired Source Button (AUX1, USB, FM1, FM2, AM, WB, AUX2, or BT) to navigate directly to that source.

*NOTE: The selected source button will illuminate orange.*

*NOTE: AUX1 will be enabled if an aux input is inserted in the front aux port. USB will be enabled if a USB is inserted into radio.*

### Source Button

- Press the Source Button to toggle through source selections.

### Preset Buttons

- Press and hold desired Preset Button to store the current radio station in that preset.
- Once set, press the desired Preset Button to navigate directly to the radio preset selection.

*NOTE: The current radio station stored will be displayed on each button.*

**Audio Settings**

**(Balance, Bass, Middle, Treble)**

- On the “Audio” screen, press the Settings Button to navigate to the “Audio Settings” screen.
- Use the slide bar (next to desired setting) to adjust desired level.

*NOTE: Slide RIGHT to adjust right-side sound levels, or LEFT to adjust left-side sound levels.*

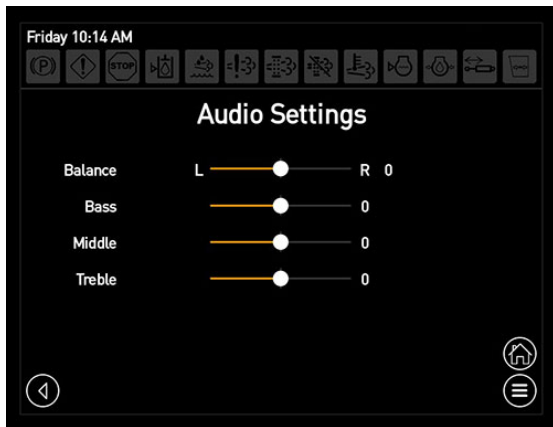

Audio Settings Screen

**Audio Shortcut Button\***

- Press the Audio Shortcut Button (located on the Home Page - Road or Field Mode) to silence/mute stereo sound. Press again to resume sound.
- Press and hold the Audio Shortcut Button to navigate to the Audio Screen.

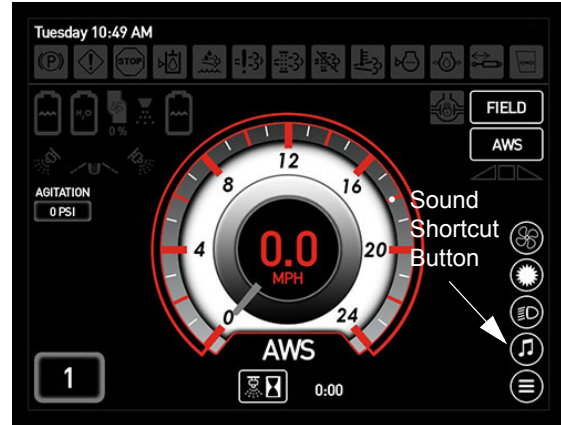

Audio Shortcut Button  
(Located on the Home Page  
- Road or Field Mode)

*\* Only displayed when the Show Shortcuts option is enabled through Display Preferences*

**Machine Adjustments**

The “Machine Adjustments” screen features various machine adjustments, such as:

- Tire Size
  - Service Intervals
  - Foamer
  - Lock (Machine Security)
  - Machine Information
  - Air Purge - *if equipped*
  - Adjust Time
- Press the Adjustments Button to navigate to the “Machine Adjustments” screen.



Adjustments Button  
(Located on the Main Menu Page)

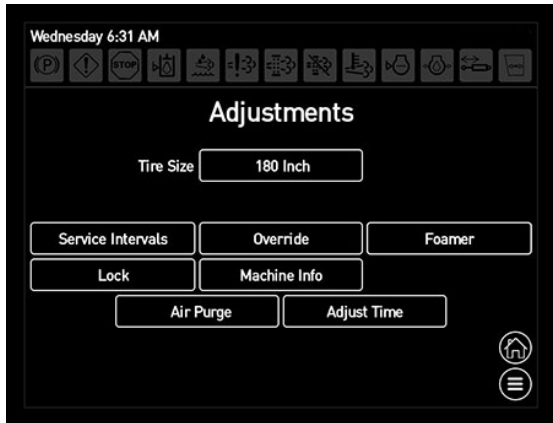

Machine Adjustments Screen

### Tire Size

*NOTE: Refer to “Tire Specifications” provided in the Introduction Section at the beginning of this manual for further information on tire options and rolling circumference values.*

#### To Change Tire Size Value

- On the “Machine Adjustments” screen, press the cell next to “Tire Size”.
- Press the “+” or “-” button to enter the rolling circumference of the tires on your machine. Press center of cell again when finished.

### Service Intervals

#### To Change Service Interval Settings

- On the “Machine Adjustments” screen, press the Service Intervals Button.
- On the “Service Intervals” screen, press the center of cell (to the far right) of the service interval you wish to change (Engine Oil, Hydraulic Filter, or Hydraulic Oil).

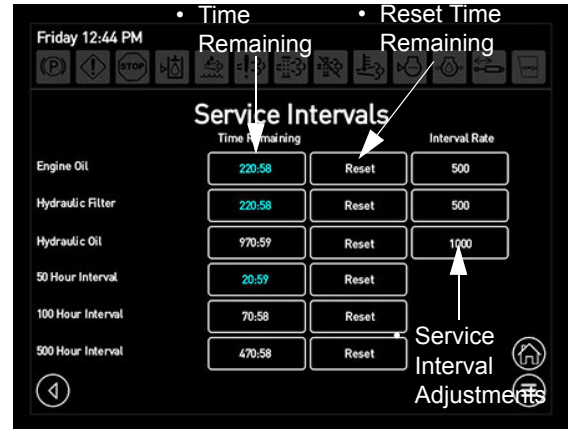

Service Intervals Screen

- Press the “+” or “-” Button(s) to adjust service interval to desired setting. Press the center of cell when finished.

*NOTE: Service interval settings cannot be set above the maximum allowed time. Refer to the Maintenance and Storage Section elsewhere in this manual for further information.*

*NOTE: Press the Reset Button to set service interval back to factory setting.*



Service Intervals Screen

- Press the corresponding Reset Button to reset the time remaining.

### Foam Marker

-If Equipped

#### Total Flow

(Adjusts Foam Frequency)

- On the “Machine Adjustments” screen, press the Foamer Button.

## SECTION 3 – CAB



- On the “Hagie Foamer” screen, use the slide bar (next to “Total Flow”) to adjust to desired foam frequency value.

*NOTE: Slide right to increase foam frequency, or left to decrease foam frequency.*

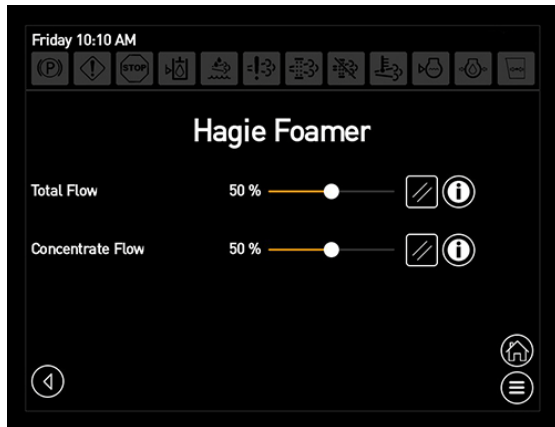

Hagie Foamer Screen

### Concentrate Flow

#### (Adjusts Foam Concentrate)

- On the “Machine Adjustments” screen, press the Foamer Button.
- On the “Hagie Foamer” screen, use the slide bar (next to “Concentrate Flow”) to adjust to desired foam concentration value.

*NOTE: Slide right to increase concentrate flow, or left to decrease concentrate flow.*

Refer to “Foam Marker System” provided in the *Spray Systems Section* elsewhere in this manual for further information.

### Lock

#### (Machine Security)

##### To Lock Machine Settings

- On the “Machine Adjustments” screen, press the Lock Button.
- On the “Change Locked Parameters” screen, select the setting(s) you wish to lock.

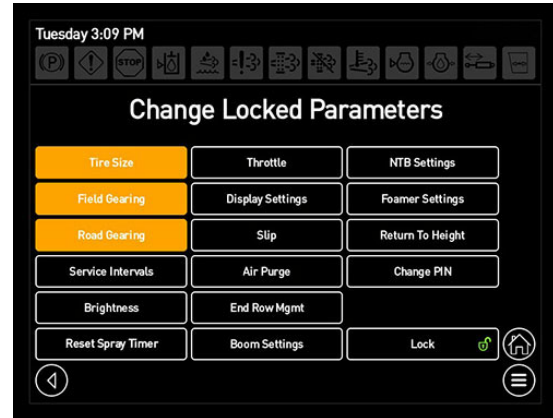

Change Locked Parameters Screen

- Press LOCK.
- Press OK to confirm lock.

##### To Unlock Machine Settings

*NOTE: Default Pin Number is “50525”.*

- On the “Change Locked Parameters” screen, press the Lock Button.

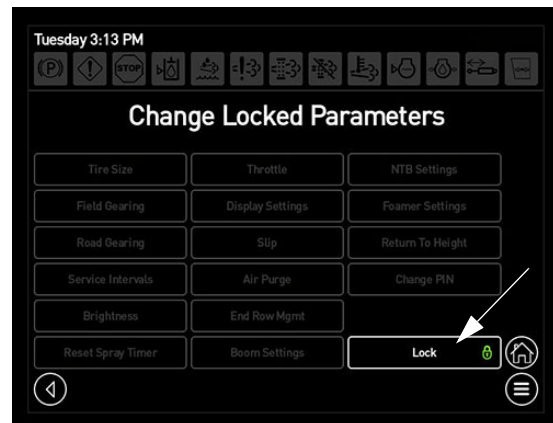

Lock Button

- On the “Password” screen, enter pin number.

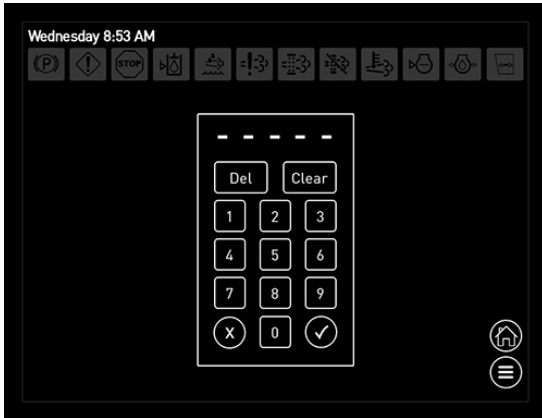

Password Screen

- Press the Accept Button when finished.

**To Change Pin Number**

- On the “Change Locked Parameters” screen, press the Change Pin Button.

*NOTE: Press the Lock Button and enter current pin number to enable the Change Pin Button.*

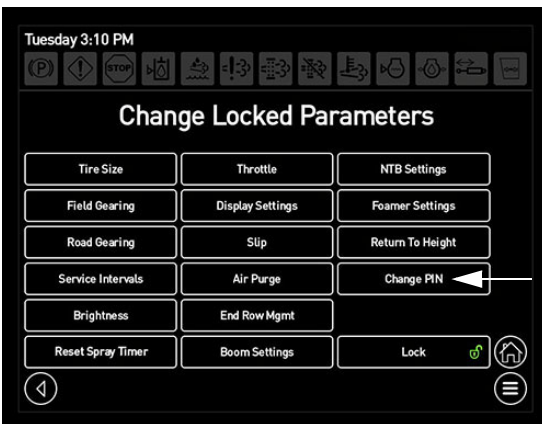

Change Pin Button

- On the “Password” screen, enter new pin number.
- Press the Accept Button when finished.

**Machine Information**

- On the “Machine Adjustments” screen, press the Info Button to navigate to the “Machine Information” screen. There you will find machine information such as total engine hours, engine serial number, software version, and attachment information.



Machine Information Screen

**Air Purge**

- If Equipped

**Air Purge Settings (Automatic Mode)**

**(Minimum Engine Speed, Full Boom Purge, Air Recharge Time, and Individual Section Purge)**

- On the “Machine Adjustments” screen, press the Air Purge Button to navigate to the “Air Purge Settings” screen.

You may also navigate to the “Air Purge Settings” screen by pressing the Settings Button (located on the “Auto Air Purge” screen). Refer to “Air Purge” elsewhere in this section for further information on automatic Air Purge settings.

**Adjust Time**

- On the “Machine Adjustments” screen, press the Adjust Time Button to navigate to the “Date/Time” screen. Modify the date/time as desired.

See “Date and Time” at the beginning of this section for further information.

**Display Preferences**

The “Display Preferences” screen features various display adjustments, such as:

- Gauge Color
- Animations
- Units (Standard, KPA, Bar)
- Date
- Time Format
- Sound Muted
- Language
- Show Shortcuts (“Quick Keys” - Home Page)

- Press the Preferences Button to navigate to the “Machine Preferences” screen.



**Preferences Button**  
(Located on the Main Menu Page)

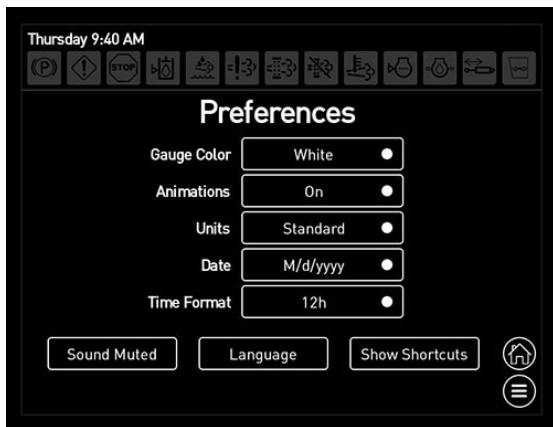

**Display Preferences Screen**

**Gauge Color**

- On the “Preferences” screen, press the cell next to “Gauge Color” and select desired speedometer color (white, red, yellow, or black).

**Animations**

- On the “Preferences” screen, press the cell next to “Animations” and select ON to enable animations, or OFF to disable animations.

**Units**

- On the “Preferences” screen, press the cell next to “Units” and select desired

units of measure to be displayed - Standard, Metric (KPA), or Metric (Bar).

**Date**

- On the “Preferences” screen, press the cell next to “Date” and select desired date format to be displayed (m/d/yyyy or d/m/yyyy).

**Time Format**

- On the “Preferences” screen, press the cell next to “Time Format” and select desired time format to be displayed - 12 hour (AM/PM) or 24 hour.

**Sound Muted**

- On the “Preferences” screen, press the Sound Muted Button to silence audible warning alarms.

*NOTE: The Sound Muted Button resets to OFF when the ignition key is cycled.*

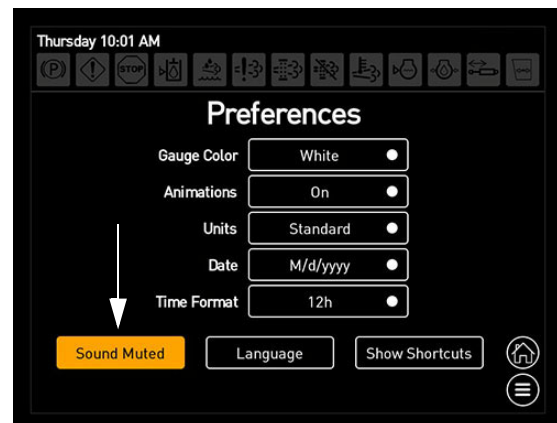

**Sound Button**  
(Located on the Preferences Screen)

**Language**

- On the “Preferences” screen, press the Language Button.
- On the “Language” screen, select desired language.





Language Screen

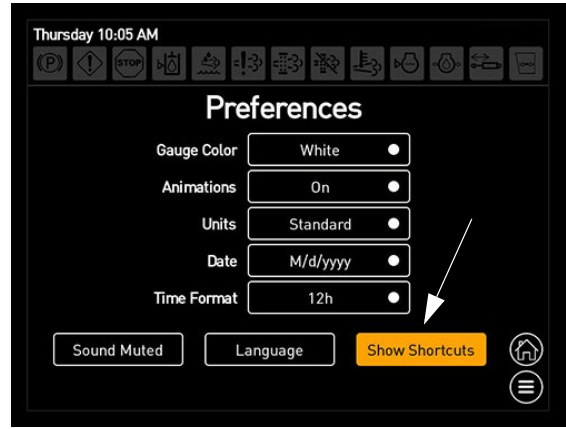

Show Shortcuts Button  
(Located on the Preferences Screen)

### Show Shortcuts

#### ("Quick Keys" - Home Page)

The four hidden "Quick Keys" are located on the Home Page - Road/Field Mode and allow the operator to turn frequently used features on/off conveniently from the Home Page.



• Reversible Fan Quick Key



• Day Time/Night Time  
Brightness Quick Key



• Exterior Lights Quick Key



• Audio Quick Key

- On the "Preferences" screen, press the Show Shortcuts Button to enable (unhide) the four Quick Keys located on the Home Page - Road/Field Mode. Press button again to disable (hide) the Quick Keys.

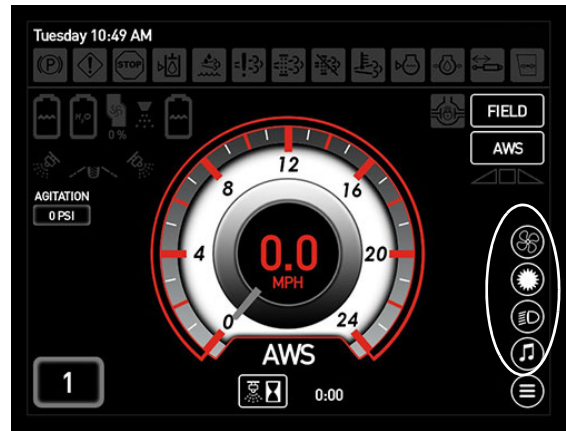

Quick Keys  
(Located on the Home Page  
- Road and Field Mode)

- Press the desired Quick Key to turn feature ON. Press again to turn feature OFF.
- Press and hold the desired Quick Key to navigate directly to that system's display page.

### Air Purge

#### -If Equipped

The Air Purge feature on your machine allows you to blow out product from the spray system. You may choose to perform the air purge in either manual or automatic mode.

- Press the Air Purge Button to navigate to the "Air Purge" screen (Manual or Automatic Mode).

*NOTE: Press the “Man” or “Auto” Button (located near the bottom of the “Air Purge” screen) to navigate directly to desired Manual or Auto Air Purge settings.*



**Air Purge Button**  
(Located on the Main Menu Page)

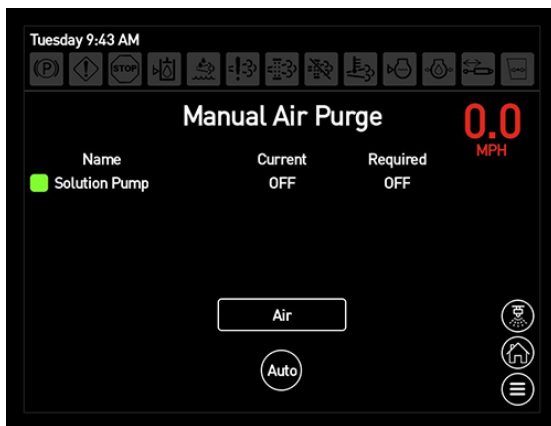

**Air Purge Screen (Manual)**

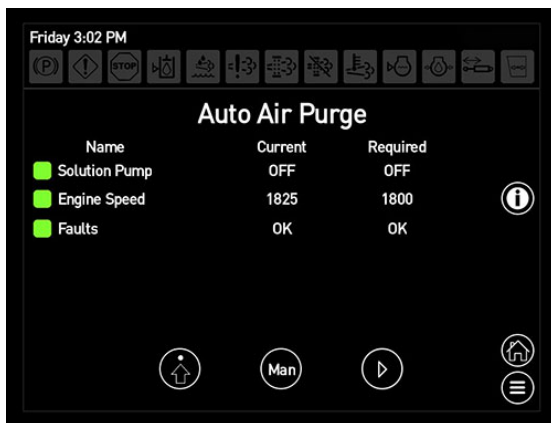

**Air Purge Screen (Auto)**

**Manual Mode**

In Manual Mode, the operator has control of the solution valves by manipulating the Boom Solution Valve Switches (located on the side console section keypad).

**To Activate the Air Purge System in Manual Mode**

- Ensure the Solution Pump Switch (located on the side console) is in the OFF position.
- Ensure the rinse, agitation, and solution tank valves are CLOSED.

*NOTE: Press and hold the Agitation Valve Switch (located on the side console) in the DOWN position for approximately 10 seconds to ensure the agitation valve is closed.*

*NOTE: These valves do not need to be closed in order for the system to operate, but are required for the Air Purge to function properly.*

- On the “Manual Air Purge” screen, press the Air Button.

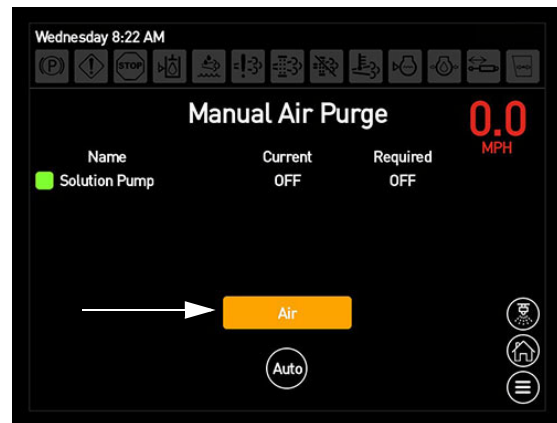

**Air Button**  
(Located on the Manual Air Purge Screen)

*NOTE: When the Air Button is depressed, it will open the air valve, releasing air into the solution system.*

- Press the Master Spray Switch (located on the Hydrostatic Drive Control Handle) in the ON position.
- Press the desired Boom Solution Valve Switches (located on the side console section keypad) to blow air and product out of the spray system.

*NOTE: Press the Solution Button (located on the Manual Air Purge Screen) to navigate to the Solution System Schematic Screen to view current solution system status.*

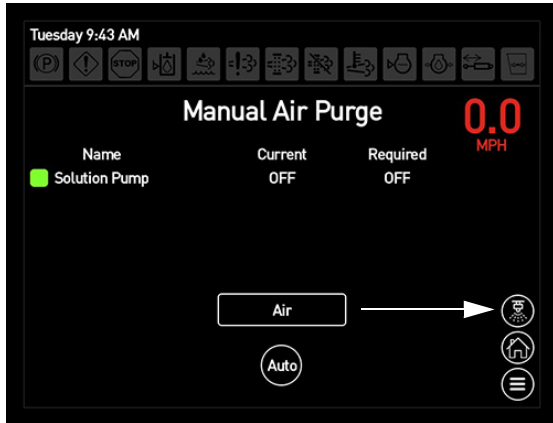

Solution Button

(Located on the Manual Air Purge Screen)

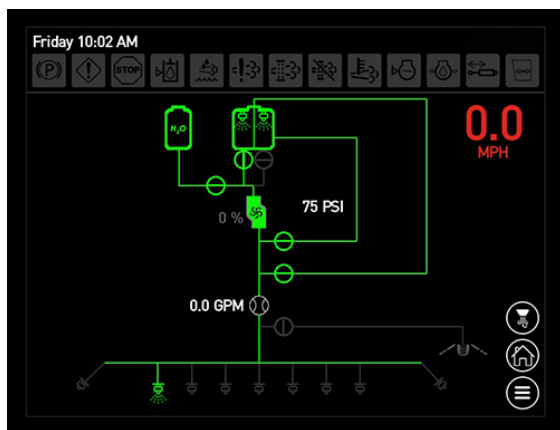

Solution System Schematic Screen

Refer to “Solution System” elsewhere in this section for further information on interpreting solution system schematics.

### Automatic Mode

In Automatic Mode, the air tank on the machine is filled based on engine speed and time to automatically recharge the air tank and purge the spray system.

### Automatic Air Purge Settings

(Minimum Engine Speed, Full Boom Purge, Air Recharge Time, and Individual Section Purge)

#### Minimum Engine Speed

- On the “Auto Air Purge” screen, press the Settings Button.

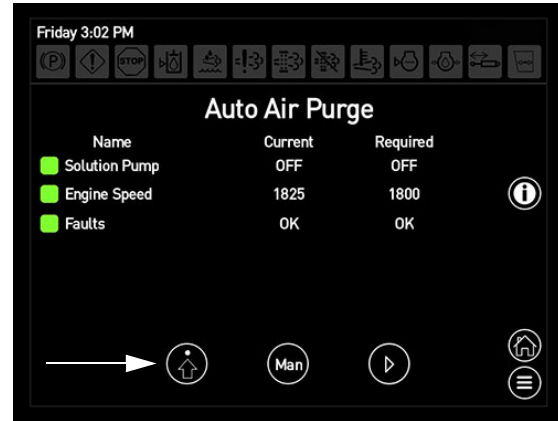

Settings Button

(Located on the Auto Air Purge Screen)

- On the “Air Purge Settings” screen, use the slide bar (next to Minimum Engine Speed) to adjust desired engine RPM.

*NOTE: Slide right to increase speed, or left to decrease speed.*

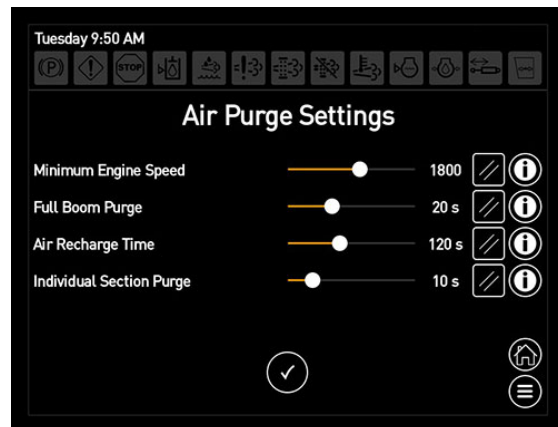

Air Purge Settings Screen

*NOTE: It is recommended for engine throttle to be above 1800 RPM. This will allow the air tank to recharge faster.*

- Press the Accept Button when finished.

#### Full Boom Purge

- On the “Auto Air Purge” screen, press the Settings Button.
- On the “Air Purge Settings” screen, use the slide bar (next to Full Boom Purge) to adjust desired value (amount of time that the entire boom will purge).

*NOTE: Slide right to increase value, or left to decrease value.*

## SECTION 3 – CAB



- Press the Accept Button when finished.

### Air Recharge Time

- On the “Auto Air Purge” screen, press the Settings Button.
- On the “Air Purge Settings” screen, use the slide bar (next to Air Recharge Time) to adjust desired value (amount of time that it takes to recharge the air tank).

*NOTE: Slide right to increase value, or left to decrease value.*

- Press the Accept Button when finished.

### Individual Section Purge

- On the “Auto Air Purge” screen, press the Settings Button.
- On the “Air Purge Settings” screen, use the slide bar (next to Individual Section Purge) to adjust desired value (amount of time that each individual section will purge).

*NOTE: Slide right to increase value, or left to decrease value.*

- Press the Accept Button when finished.

*NOTE: When purging individual sections, the system will start with the leftmost section that is not turned off (on the section keypad) and continue to the rightmost section that is not turned off.*

#### **Example:**

*If Sections 1, 2, 6, and 7 are turned off and all others are on, then Sections 3-5 will be purged. The left fence row nozzle will be purged when Section 1 is purged (and full boom), and the right fence row nozzle will be purged when Section 9 is purged (and full boom), unless the fence row nozzles are turned off through the section keypad. The rear nozzle will purge with Section 5 (and full boom), unless the rear nozzle is turned off through the section keypad.*

### **To Activate the Air Purge System in Automatic Mode**

- Ensure the Solution Pump Switch (located on the side console) is in the OFF position.

- Ensure the solution tank, rinse, and agitation valves are CLOSED.

*NOTE: Press and hold the Agitation Valve Switch (located on the side console) in the DOWN position for approximately 10 seconds to ensure the agitation valve is closed.*

- Throttle engine to desired RPM (above 1800 RPM).

*NOTE: 1800 RPM is the minimum engine speed setting to activate the Air Purge System in Automatic Mode.*

- Ensure that no system faults are present.
- On the “Auto Air Purge” screen, ensure all previous requirements have been met.

*NOTE: Auto Air Purge will not activate until all requirements have been met.*

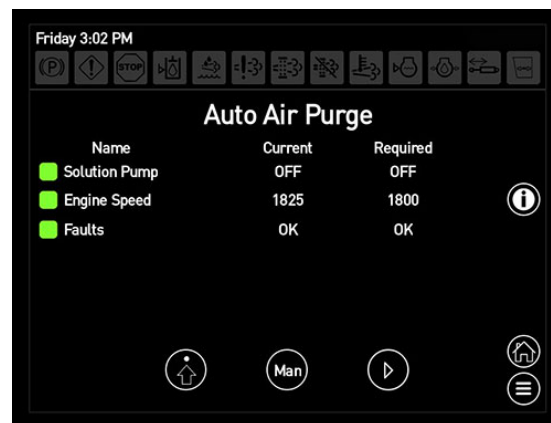

Auto Air Purge Screen

- Press the Start Button to begin purge.

*NOTE: The Air Purge system will cycle as follows: full boom purge, air tank recharge, individual section purge. If the operator does not want a particular section to purge, press the corresponding Boom Solution Valve Switch (located on the side console section keypad) in the OFF position.*

*NOTE: A progress bar is located near the bottom of the screen to display current system status of the automatic air purge process.*

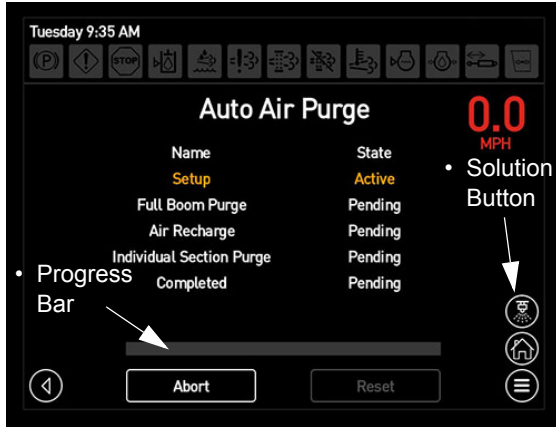

Auto Air Purge Screen - Auto Cycle

*NOTE: Press the Abort Button to stop air purge.*

*NOTE: Press the Solution Button (located on the Auto Air Purge Screen - Auto Cycle) to navigate to the Solution System Schematic Screen to view current solution system status.*



Solution System Button  
(Located on the Main Menu Page)

- Rinse Tank
- Solution Tanks
- Solution Tank Valves On/Off

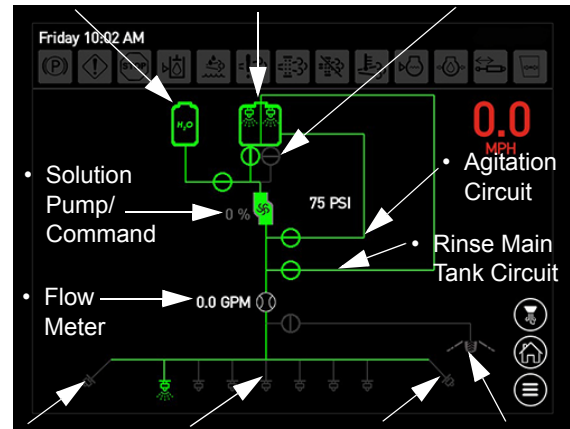

- Left Fence Row
- Boom Solution Valves (Sections 1-9)
- Right Fence Row
- Rear Tire Track Nozzle

Solution System Schematic Screen

*NOTE: Circles with lines through them are solution valves. When green, the valve is activated. If gray with perpendicular line, the valve is off.*

*NOTE: When the Fence Row and Boom Solution Valves (located at the bottom of schematic) are green, the corresponding valve is activated and spraying.*

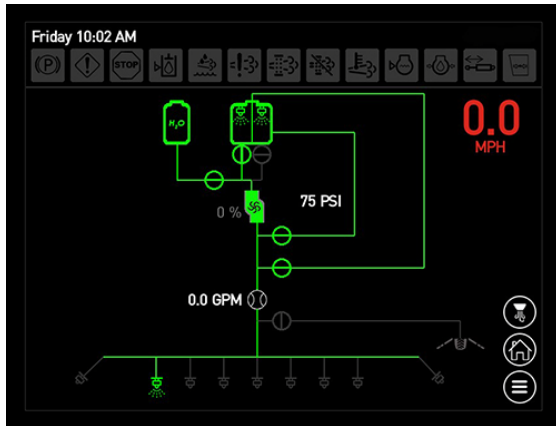

Solution System Schematic Screen

Refer to “Solution System” elsewhere in this section for further information on interpreting solution system schematics.

## Solution System

The “Solution System Schematic” screen allows the operator to view current solution system status.

- Press the Solution System Button to navigate to the “Solution System Schematic” screen.

## System Faults

The “System Faults” screen displays various machine faults, such as:

- Primary

## SECTION 3 – CAB



- Secondary
  - Display
  - Engine
  - Attachment
- 
- Press the Faults Button to navigate to the “System Faults” screen.



Faults Button  
(Located on the Main Menu Page)

- On the “System Faults” screen, press desired fault button to navigate to the corresponding fault screen, which will display the fault code and fault description.

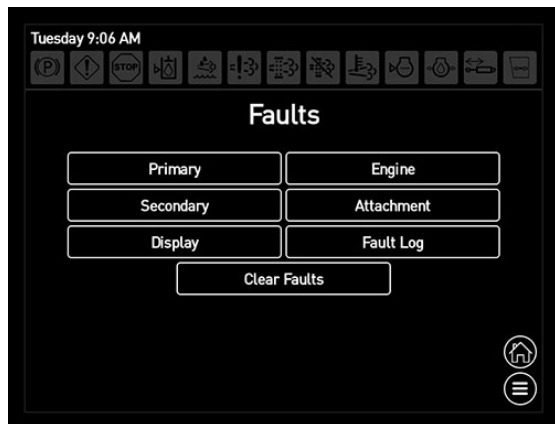

System Faults Screen



Secondary Faults Screen

### Active Faults

When a system fault occurs, a warning message will appear on any given display page, which will inform you of the fault code and the reason for the fault. Press OK to acknowledge.

*NOTE: Each Active Fault will display the fault code and description. Refer to fault code when speaking with your local John Deere dealer.*

In the event that a severe system malfunction should occur and cause the machine to operate outside of normal operating conditions (i.e. All-Wheel Steer fault, tire size not selected, etc.), a Machine Malfunction Warning message will appear on the display. This warning message will inform you that a malfunction was detected and that the machine is not responding normally and you must operate with extreme caution, as machine speed will be limited and stopping distance may be increased or decreased. Press OK to acknowledge.

In addition, a second warning message will appear informing you of the specific fault description. Contact your local John Deere dealer for assistance.

**⚠ CAUTION**

Machine speed will be limited and stopping distance may be increased or decreased following a machine fault warning.

**⚠ CAUTION**

Do not operate the machine following a machine fault warning. Failure to comply may result in personal injury and machine damage.

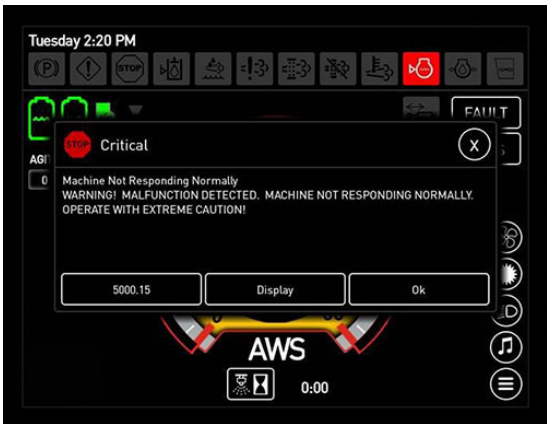

Machine Malfunction Warning

**Fault Log**

- On the “System Faults” screen, press the Fault Log Button.

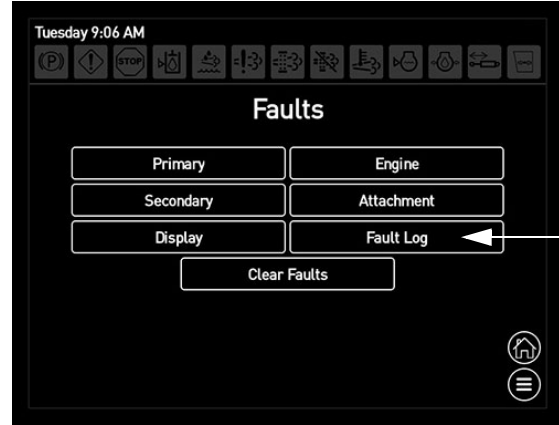

Fault Log Button  
(Located on the System Faults Screen)

- On the “Faults” screen, you will be able to view all previous system faults.

*NOTE: System faults are listed with the most current fault at the top of the screen. Swipe the screen up or down to scroll through faults.*



Faults Screen

**Clear Faults**

- On the “System Faults” screen, press the Clear Faults Button to remove faults after the fault issue has been resolved.

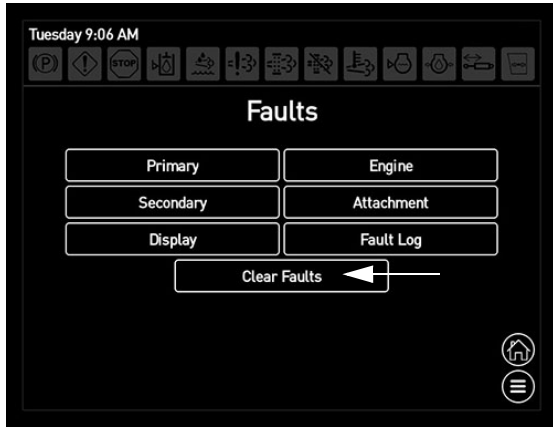

**Clear Faults Button**  
(Located on the System Faults Screen)



**Measure Button**  
(Located on the Main Menu Page)

*NOTE: A “Clear Faults Confirmation” message will appear. Press OK to confirm.*

- On the “Measurements” screen, select desired system to view current system status.

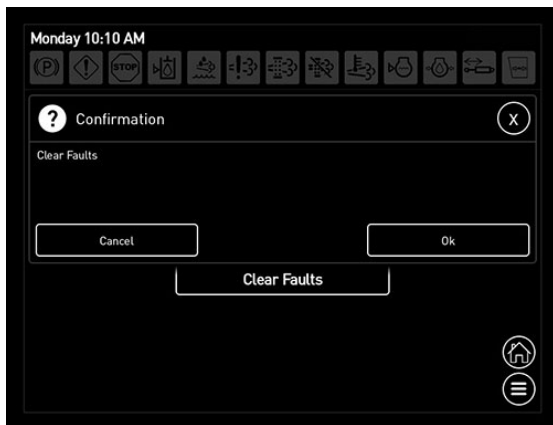

**Clear Faults Confirmation**

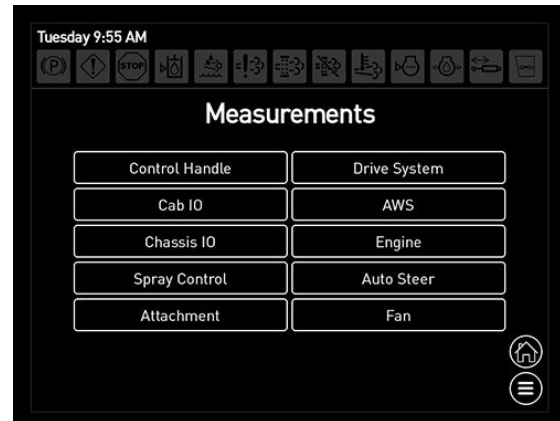

**Measurements Screen**

*NOTE: System Faults will continue to appear until the fault issue has been resolved, regardless of clearing the faults.*

**Measure**

While either parked or operating the machine, current system measurements can be viewed when diagnosing or troubleshooting.

- Press the Measure Button to navigate to the “Measurements” screen.

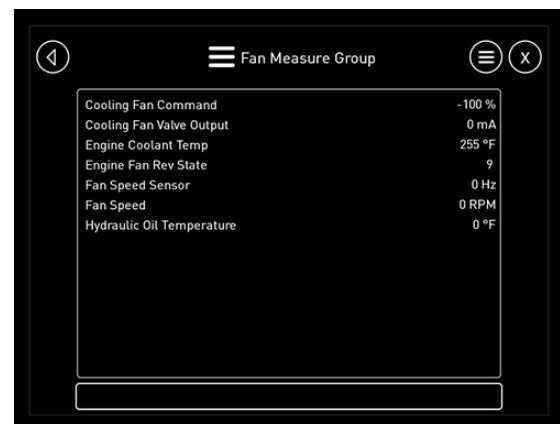

**System Status Screen**





## SECTION 4 – ENGINE AND DRIVE SYSTEMS

### ENGINE - STARTING

#### **CAUTION**

Start engine from the operator's seat only. When running the engine in a building, ensure there is adequate ventilation.

*NOTE: An Insufficient Cab Air Pressure Indicator will appear on the Machine Display Home Page - Road or Field Mode each time the machine is started, due to a slight activation delay of the RESPA® Cab Filtration System. The indicator will disappear once the cab becomes pressurized.*

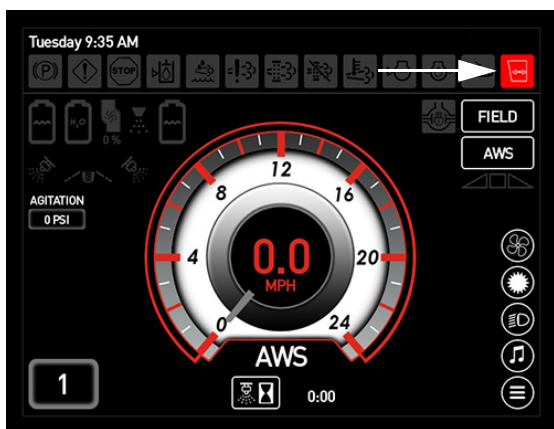

Insufficient Cab Air Pressure Indicator  
(Located on the Machine Display Home Page - Road or Field Mode)

### Pre-Operational Checklist

1. Check engine oil level.

*NOTE: Do not operate the machine when oil level is below the "L" (low) mark or above the "H" (high) mark on the engine oil dipstick.*

2. Check coolant level.

3. Check diesel exhaust fluid level (Final Tier 4 engines only).
4. Check hydraulic reservoir oil level.
5. Check cooling air intake screen.
6. Drain fuel/water separator.
7. Check engine drive belt.
8. Drain water out of the air tank.
9. Check for any oil or fuel leaks.

### Cold Start Procedure

1. Engage the parking brake.

*NOTE: Refer to "Hydrostatic Drive" provided elsewhere in this section for further information.*

2. Turn the Ignition ON, but DO NOT engage the starter. **(Wait for the Grid Heater ON indicator to disappear on the Machine Display).**

The following warning message will appear on the Machine Display during cold weather conditions. Press OK (acknowledging that you understand the engine requires a warm-up period before engaging the starter).

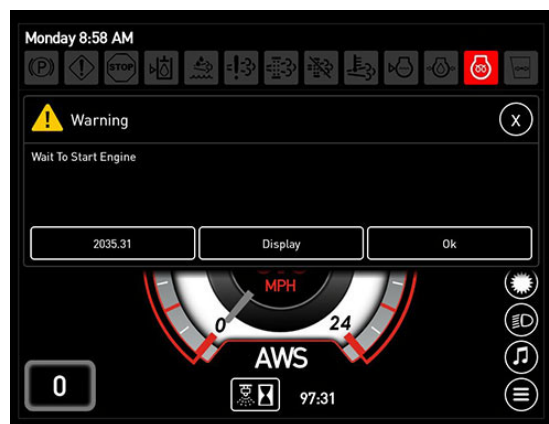

*NOTE: Ensure that there are no other warnings before proceeding.*

3. Engage the starter.  
**(If the engine fails to start after 15 seconds, turn the key OFF, wait one minute, and repeat the procedure. If the engine does not start after three attempts, check the fuel supply system).**

## SECTION 4 – ENGINE AND DRIVE SYSTEMS



*NOTE: Tier 3 Engines (export only) -  
Absence of blue or white exhaust  
smoke while cranking indicates that  
no fuel is being delivered.*

4. Observe warning lights on the Machine Display (after start-up).

*NOTE: If any functions do not operate, shut  
the engine OFF and determine  
cause.*

5. Allow a warm-up period of at least five (5) minutes before operating the engine at a high RPM.

*NOTE: The engine must reach operating  
temperature and oil pressure must  
stabilize in the normal operating  
range before it is run faster than idle  
speed (1,000 RPM or less).*

6. Disengage the parking brake.

### Jump Starting

1. Engage the parking brake.
2. Rotate the Battery Disconnect Switch (located on the rear mainframe) to the ON position.

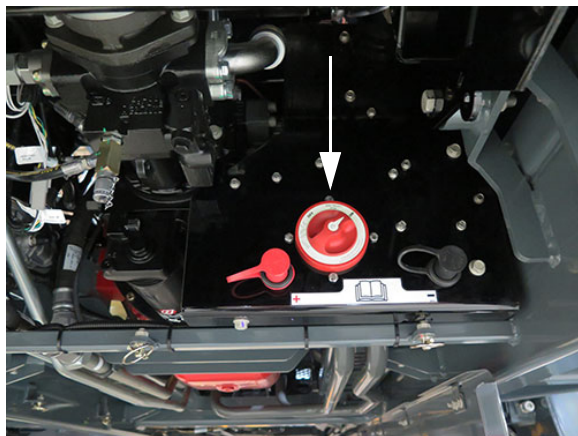

Battery Disconnect Switch  
(Located on the rear mainframe)  
-Typical View

3. Remove caps from the Auxiliary Battery Charging Posts (located on the rear mainframe).

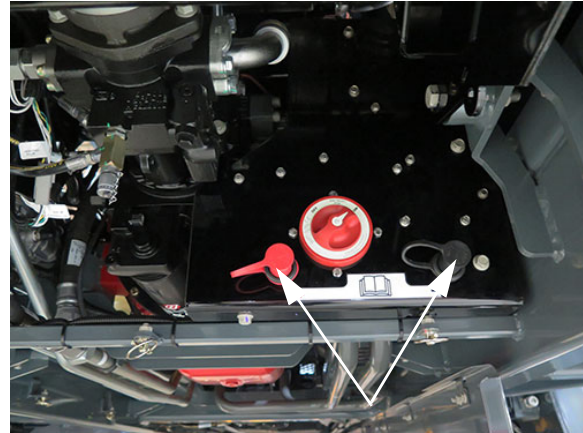

Auxiliary Battery Charging Posts  
(Located on the rear mainframe)  
-Typical View

4. Connect cables from charging device (i.e. battery charger or another machine) to the Auxiliary Battery Charging Posts - positive cable to the positive terminal, and negative cable to the negative terminal.
5. Allow batteries to charge approximately 5-10 minutes.

### NOTICE

Do not over-crank the starter. Failure to comply may result in starter damage.

6. Engage the starter by starting the machine.
7. Remove the charging cables in reverse to the way you attached them (negative cable first, then positive cable).

*NOTE: Ensure that the charging cables do  
not touch together or to any metal  
surface.*

8. Reinstall the Auxiliary Battery Charging Post caps.
9. Allow engine to idle for approximately 5 minutes to recharge the batteries.

*NOTE: Longer idle time may be required,  
depending on how depleted the  
batteries are.*

**ENGINE  
AFTERTREATMENT - FINAL  
TIER 4****⚠ WARNING**

It is unlawful to tamper with or remove any component of the Aftertreatment System. It is also unlawful to use Diesel Exhaust Fluid (DEF) that does not meet the specifications provided or to operate the machine with no DEF.

**⚠ WARNING**

DEF contains urea. Do not get the substance in your eyes. In case of contact, immediately flush eyes with large amounts of water for a minimum of 15 minutes. Do not swallow internally. In the event the DEF is ingested, contact a physician immediately.

**⚠ WARNING**

Read the DEF manufacturer's label and comply with safety precautions to avoid injury or damage.

**⚠ CAUTION**

Never attempt to create DEF by mixing agricultural grade urea with water. Agricultural grade urea does not meet the necessary specifications required and the Aftertreatment System may be damaged.

**⚠ CAUTION**

Aftertreatment DOC and DRT components may be hot. Allow engine to cool before handling. Failure to comply may result in injury.

**⚠ CAUTION**

Never add water or any other fluid besides what is specified to the DEF tank. Failure to comply may result in Aftertreatment System damage.

**⚠ CAUTION**

Do NOT add any chemicals/additives to the DEF in an effort to prevent freezing. If chemicals/additives are added to the DEF, the Aftertreatment System may become damaged.

**⚠ CAUTION**

When performing a stationary exhaust system cleaning, ensure the exhaust pipe outlet is not directed at any surface or material that may become hazardous.

## NOTICE

### USE CORRECT FLUID TYPES

- Use only low-ash diesel engine oil.
- Use only ultra-low sulfur diesel (ULSD) fuel.
- Use only DEF meeting ISO 2224101 standards.

**Failure to use the required fluid types will result in engine damage and will void the warranty.**

## NOTICE

Never operate the engine with low DEF level.

## NOTICE

Do not direct water into exhaust opening. Failure to comply may result in system damage and will void the warranty.

## NOTICE

### DEF CAN BE CORROSIVE TO CERTAIN MATERIALS

- Use only approved containers to transport or store DEF (polyethylene and polypropylene containers recommended).
- If DEF is spilled, rinse and clean immediately with water.
- Avoid contact with skin. If contact occurs, wash off immediately with soap and water.

## NOTICE

Wipe up spills immediately with clean water. If DEF is left to dry, a white residue will remain. Failure to clean spilled DEF appropriately may result in an incorrectly diagnosed leak of the DEF Dosing System.

## NOTICE

Thoroughly wash any containers, funnels, etc. that will be used to dispense, handle, or store DEF. **Rinse with distilled water only.** Use of tap water to rinse components will contaminate the DEF.

## NOTICE

If incorrect fluid is mistakenly added to the DEF tank (e.g. water, diesel fuel, hydraulic oil, engine coolant, windshield washer fluid, etc.), contact the engine manufacturer to determine the appropriate repair.

The Final Tier 4 diesel engine is featured with a flow-through exhaust Aftertreatment System that delivers ultra-low emissions for cleaner air quality.

*NOTE: When the ignition key is turned to the OFF position, DEF returns to the DEF tank.*

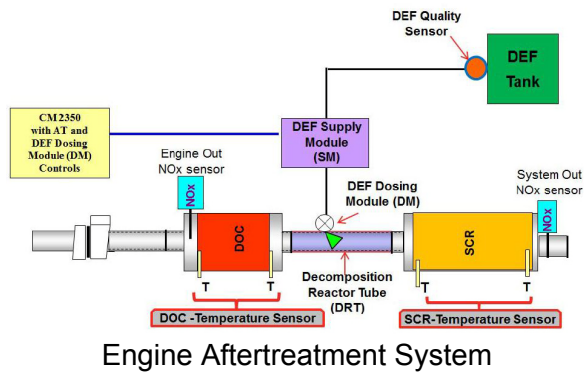

### Aftertreatment System Components

- Final Tier 4 Diesel Engine
- Diesel Exhaust Fluid (DEF) Tank
- Diesel Exhaust Fluid (DEF) Gauge
- Diesel Oxidation Catalyst (DOC)
- Decomposition Reactor Tube (DRT)
- Selective Catalytic Reduction (SCR)
- DEF Dosing Module
- DEF Supply Module
- DEF Supply Module Filter
- DEF Quality Sensor
- DEF Suction Strainer

### Final Tier 4 Diesel Engine

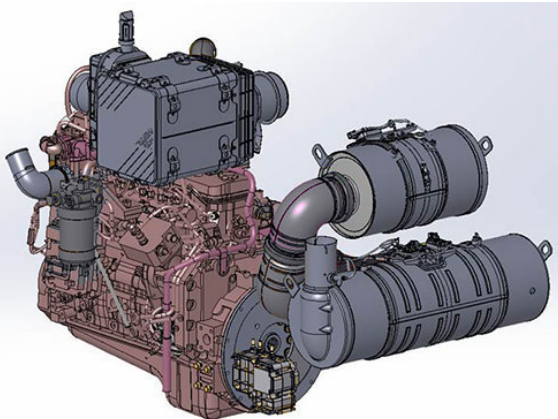

Final Tier 4 Diesel Engine  
(Located near rear of machine  
- open hood to access)  
-Typical View

### DEF Tank

- DEF Tank Capacity = 5 Gallons (18.9L)

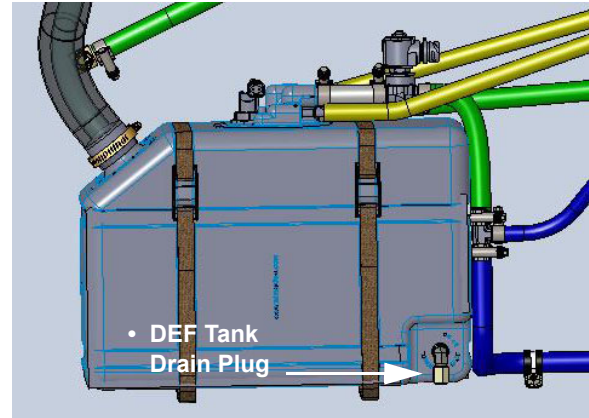

DEF Tank  
(Located along rear left-hand  
side of engine compartment)  
-Typical View

### DEF (Diesel Exhaust Fluid)

DEF is used in Selective Catalyst Reduction (SCR) Systems to help convert nitrogen oxide (NO<sub>x</sub>) emissions in engine diesel exhaust into harmless nitrogen and water vapor.

*NOTE: Check DEF level daily.*

#### Fluid Type:

- Use only DEF which meet ISO 2224101 standards.

*NOTE: John Deere Diesel Exhaust Fluid recommended.*

#### Fluid Storage:

- Store DEF between 23° F (-5° C) and 77° F (25° C).
- Refer to “Service - Fluids” provided in the *Maintenance and Storage Section* elsewhere in this manual for additional information.

#### Fluid Disposal:

- Check with local authority regulations on proper DEF disposal requirements.

### DEF Gauge

The DEF Gauge (located on the cab A-post and on the Machine Display “Engine Diagnostics” screen) allows the operator to view current DEF tank level at all times.



**DEF Gauge**  
(Located on cab A-post)  
-Typical View

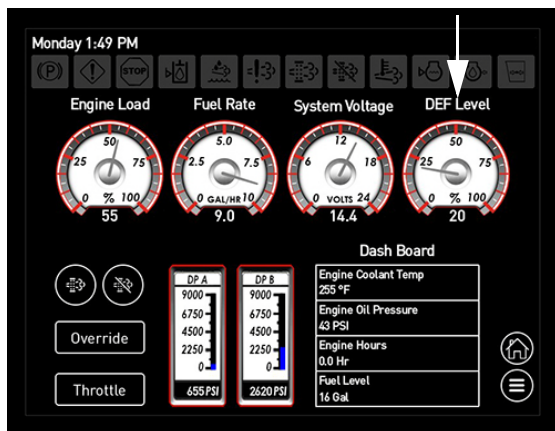

**DEF Gauge**  
(Located on the Machine Display -  
Engine Diagnostics Screen)  
-Typical View

**SCR (Selective Catalytic Reduction)**

The SCR is where the DEF reduces gaseous nitrogen oxide (NOx) to near zero levels by converting into nitrogen gas and water vapor.

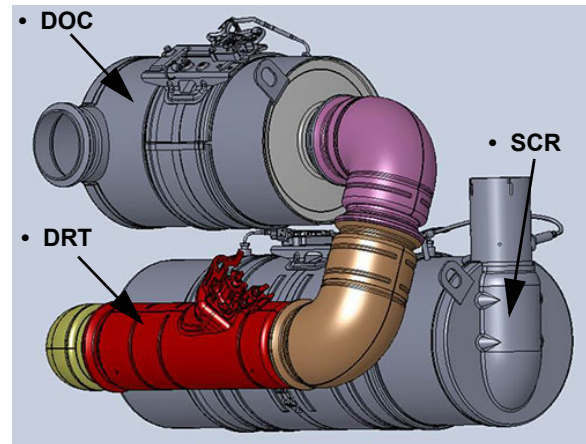

-Typical View

**DEF Dosing Module**

The DEF Dosing Module allows a fine mist of DEF to be sprayed into the hot exhaust.

**DEF Supply Module**

The DEF Supply Module pumps DEF from the tank to the Dosing Injector (located in the DRT).

**DEF Supply Module Filter**

The DEF Supply Module Filter (located beneath rear of machine) filters DEF before going to the Dosing Injector. Change filter every 4,500 hours of operation or every 3 years, whichever occurs first.

*NOTE: Refer to the engine manufacturer's operation manual for further information.*

**DOC (Diesel Oxidation Catalyst)**

The DOC reduces carbon monoxide and hydrocarbons produced by the engine.

**DRT (Decomposition Reactor Tube)**

The DRT is a mixer tube where DEF is injected and mixes with exhaust from the diesel engine, which is then converted into ammonia.

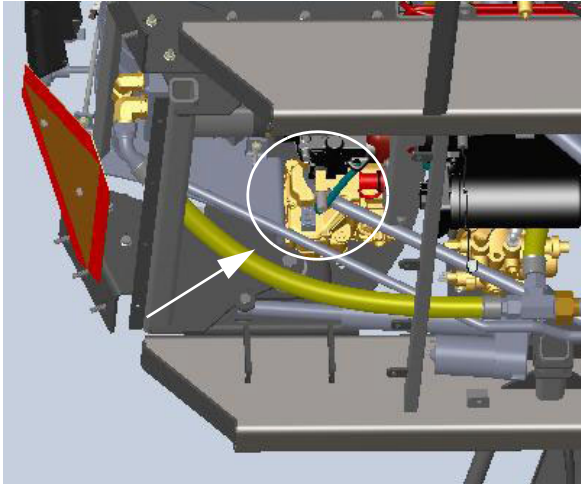

DEF Supply Module Filter  
(Located beneath rear of machine)  
-Typical View

\* Rear underside of machine shown

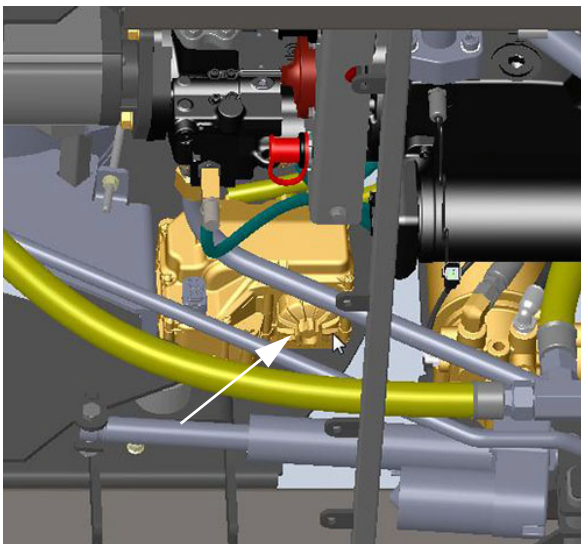

DEF Supply Module Filter  
(Closeup View)

to drain sediment from tank. Remove and clean Suction Strainer, ensuring the strainer is reinstalled correctly when finished.

*NOTE: Flush DEF Tank and components with distilled water only to remove any contamination. Refer to the engine manufacturer's operation manual for further information.*



DEF Suction Strainer  
(Located near bottom of the DEF Tank)  
-Typical View

### DEF Quality Sensor

The DEF Quality Sensor (located inside the tank) detects DEF tank level, as well as quality and temperature of the DEF, which are required for the Aftertreatment System to function properly.

### DEF Suction Strainer

The DEF Tank is equipped with a Suction Strainer (located near bottom of tank). If degraded system performance occurs, remove drain plug (located at bottom of tank)

### Filling the DEF Tank

#### DEF Indicator Lamps (Located on the Machine Display)



- **DEF Indicator Lamp** - Illuminates when the DEF level is low, and flashes when the DEF falls below a very low level. Operator should refill the DEF tank with DEF.



- **Flashing DEF Indicator Lamp with Check Engine Indicator Lamp** - Illuminates when the DEF level is critically low. If the tank is not refilled immediately, power will be reduced. Operator should refill the DEF tank with DEF. Normal engine power will be restored after the DEF tank is refilled.



FLASHING



- **Flashing DEF Indicator Lamp with Stop Engine Indicator Lamp** - Illuminates when the DEF gauge reads zero. Power will be reduced or limited to idle. Operator should stop the machine when it is safe to do so and refill the DEF tank. Normal engine power will be restored once the DEF tank is refilled.

1. Shut the engine OFF.
2. Remove the DEF Fill Cap (located on left-hand side of hood) and set aside.



DEF Fill Cap  
(Located on left-hand side of hood)  
-Typical View

3. Fill tank with DEF.
4. Reinstall the DEF Fill Cap.

*NOTE: Refill tank with DEF every other fuel fill.*

### Stationary Exhaust System Cleaning

Your Final Tier 4 diesel engine requires little or no operator interaction. Under certain circumstances, an operator-initiated Exhaust System Cleaning may be required. Exhaust System Cleaning Indicator Lamps (located on the Machine Display) will illuminate to show system status.



### Exhaust System Cleaning Indicator Lamps

(Located on the Machine Display)



- **High Exhaust System Temperature (HEST) Indicator Lamp** - May illuminate due to higher than normal exhaust temperature during Exhaust System Cleaning. Operator should ensure that the exhaust pipe outlet is not directed at any flammable or combustible surfaces.



- **Exhaust System Cleaning Indicator Lamp** - Illuminates when the exhaust system is unable to complete an automatic Exhaust System Cleaning event. Operator should ensure that the Exhaust System Cleaning Switch is not in the STOP position and continue working until there is an opportunity, such as at the end of the work day or shift to complete a stationary Exhaust System Cleaning.



- **Exhaust System Cleaning Indicator Lamp with Check Engine Indicator Lamp** - If an Exhaust System Cleaning is not performed in a timely manner after the Exhaust System Cleaning Indicator Lamp is illuminated, the Check Engine Indicator Lamp will illuminate and engine power will be significantly reduced. Park the machine when safe to do so and press the Exhaust System Cleaning Start Switch. Once cleaning is complete, full engine power will be restored.



- **Exhaust System Cleaning Indicator Lamp** - Flashes when a stationary Exhaust System Cleaning event is initiated using the Exhaust System Cleaning Start Switch. This lamp will continue to flash until the stationary cleaning event is complete. Once the lamp turns off, the operator can resume normal operation.



- **Exhaust System Cleaning Stop Indicator Lamp** - Illuminates when the Exhaust System Cleaning Switch is in the STOP position, preventing a cleaning event. This switch should be used only when high exhaust temperatures present a hazard. Excessive use of the Exhaust System Cleaning Switch in the STOP position will result in the need for more frequent stationary exhaust cleaning events.



- **Stop Engine Indicator Lamp** - Illuminates when continued operation could result in damage to the exhaust system. Shut down the engine as soon as it is safe to do so and call for service to avoid damage to the exhaust system.

### To Perform an Exhaust System Cleaning

1. Park the machine in a safe location where the exhaust pipe outlet will not face any combustible surface.
2. Engage the parking brake.
3. With the engine running and at idle, press the Manual Regen Button (located on the Machine Display - “Engine Diagnostics” screen).

*NOTE: When the cleaning event is activated, engine speed may increase and the HEST Indicator Lamp (located on the Machine Display) may illuminate and the Exhaust System Cleaning Indicator Lamp will flash.*

4. Monitor the machine and surrounding area for safety.

*NOTE: If the machine needs to be used or moved, stop the stationary cleaning event by increasing the Throttle Switch (located near the Hydrostatic Drive Control Handle).*

5. When the Exhaust System Cleaning is complete, the engine will return to normal idle speed and the HEST and Exhaust System Cleaning Indicator Lamps will turn off.

## SECTION 4 – ENGINE AND DRIVE SYSTEMS



### Further Information

Refer to the *Maintenance and Storage Section* provided elsewhere in this manual for additional Aftertreatment service and maintenance information.

Refer to the engine manufacturer's operation manual for complete operating instructions and safety precautions.

---

## HYDROSTATIC DRIVE

The Hydrostatic Drive System uses pressurized hydraulic fluid to drive the machine. The Hydrostatic Drive System consists of four components: Diesel Engine, Hydrostatic Pump, Wheel Motors, and Wheel Hubs.

### Hydrostatic Drive Components

- Cummins® Diesel Engine
- Hydrostatic Pump
- Wheel Motors (4)
- Wheel Hubs (4)

### Engine and Hydrostatic Pump

Your machine is featured with a Cummins diesel engine (located beneath the rear hood). The engine has a direct-mounted Hydrostatic Pump (located near center of machine).

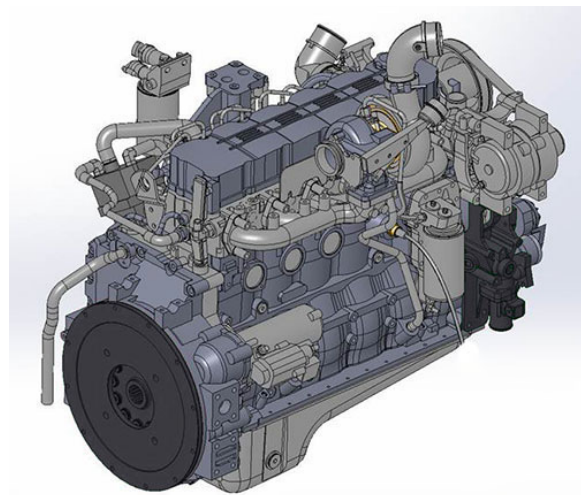

Tier 3 Diesel Engine  
(Export only)  
-Typical View

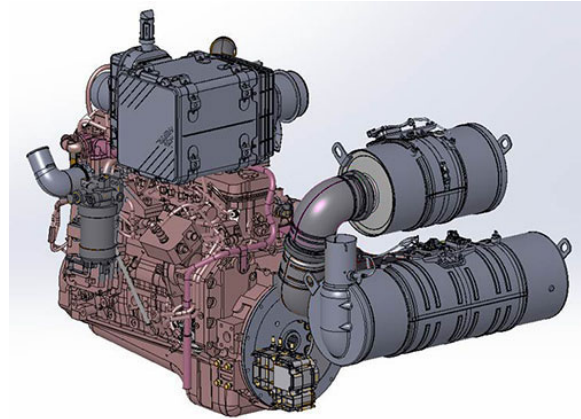

Final Tier 4 Diesel Engine  
-Typical View

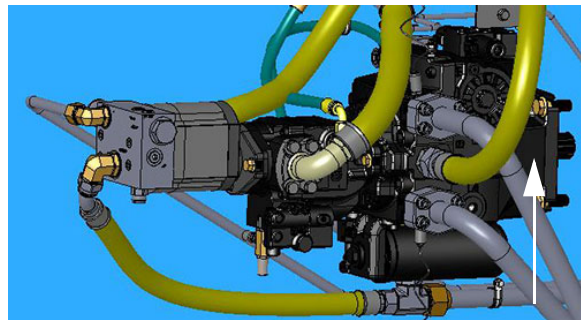

Hydrostatic Pump (Drive Pump)  
-Typical View

### Wheel Motors and Hubs

The drive system consists of hydraulic Wheel Motors and Gear Reduction Hubs (Wheel Hubs) located on each wheel.

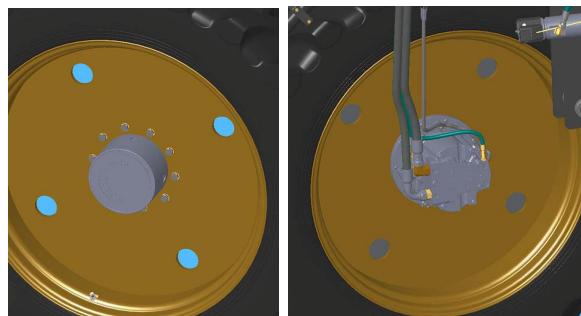

Wheel Motor/Hub Assembly  
-Typical View

## Parking Brake

The Parking Brake will engage when applied hydraulic pressure falls below 150 PSI (10.3 bar) or if the engine is shut off.

### **⚠ CAUTION**

Do not engage the parking brake while the machine is moving. Failure to comply may result in personal injury and machine damage.

### **NOTICE**

The parking brake is not intended for normal or emergency stopping.

*NOTE: Bring the machine to a complete stop before engaging the Parking Brake.*

The Parking Brake also controls the Ladder. When the Parking Brake is engaged, the Ladder will extend (lower). When the Parking Brake is disengaged, the Ladder will retract (raise).

### To Engage the Parking Brake

### **⚠ CAUTION**

Ensure the Hydrostatic Drive Control Handle is in the NEUTRAL position before engaging the parking brake. Failure to comply may result in personal injury and/or machine damage.

- **To engage the Parking Brake and lower the Ladder**, move the Hydrostatic Drive Control Handle to the NEUTRAL position.

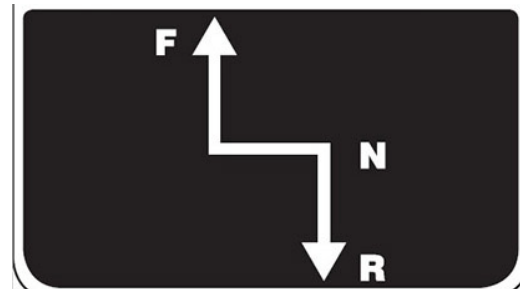

Hydrostatic Drive Control Handle  
-Typical View

- Slide the red safety lever (located on the Parking Brake Switch) DOWN (Back) and press top of switch DOWN.

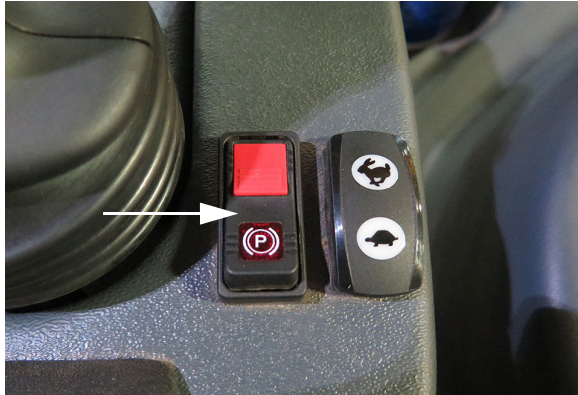

**Parking Brake Switch**  
(Located near the Hydrostatic  
Drive Control Handle)  
-Typical View

*NOTE: When the Parking Brake is engaged, a parking brake indicator (located on the top left-hand side of each Machine Display page) and the Parking Brake Switch will illuminate.*

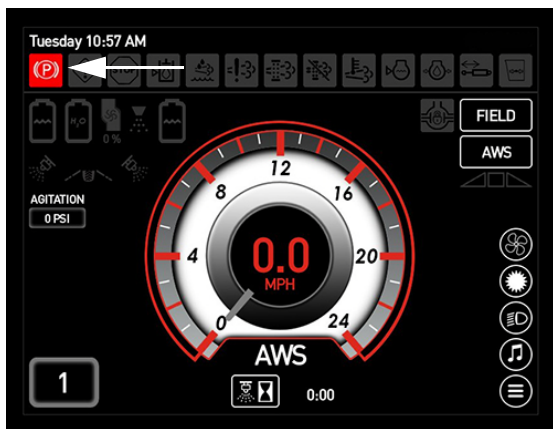

**Parking Brake Indicator**  
(Located on the top left-hand  
side of each Machine Display page)

### To Disengage the Parking Brake

*NOTE: If the Hydrostatic Drive Control Handle is out of neutral while the parking brake is engaged, a warning message will appear on the Machine Display stating, "Parking Brake on with control handle out of neutral. Return control handle to neutral and toggle Parking Brake Switch to release." Press OK to acknowledge.*

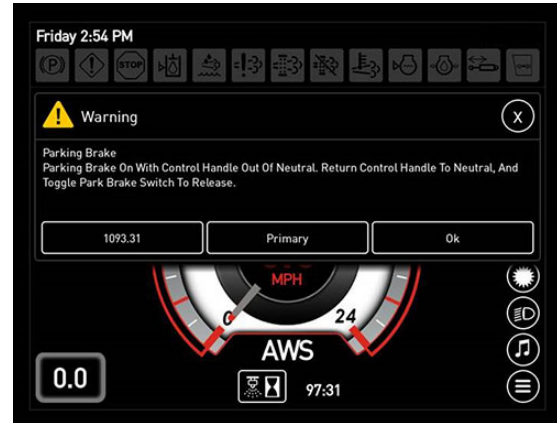

**Parking Brake Warning**

- **To disengage the Parking Brake and raise the Ladder**, press the Parking Brake Switch in the DOWN (Off) position.

### Deceleration (Decel) Pedal



When nearing an end row and speed deceleration is desired, press the Decel Pedal (located to the lower right-hand side of the steering column) to decrease speed.

*NOTE: When the Decel Pedal is fully pressed, vehicle speed decreases to 0.*



**Decel Pedal**  
(Located to the lower right-hand  
side of the steering column)  
-Typical View

### Speed Range

Your machine is featured with three speed ranges - Speed Range 1, Speed Range 2, and Speed Range 3. The speed range selected is displayed on the Machine Display Home Page - Road and Field Mode.

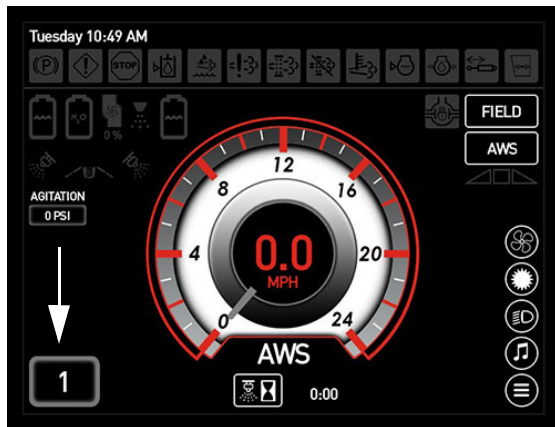

**Speed Range**  
(Located on the Machine Display  
Home Page - Road and Field Mode)

### Speed Range 1

In Speed Range 1, all wheel motors are at maximum displacement. Machine speed ranges from 0-14 mph (0-22.5 km/h)\*.

### Speed Range 2

In Speed Range 2, the front wheel motors are shifted to minimum displacement. Machine speed ranges from 0-20 mph (0-32 km/h)\* with slightly less torque.

### Speed Range 3

In Speed Range 3, the front and rear wheel motors are shifted to minimum displacement. Machine speed ranges from 0-30 mph (0-48 km/h)\*.

*NOTE: Speed Range 3 is available in Road Mode only. This range is always set to maximum speed and is non-operator adjustable.*

*\* Speed ranges may vary, depending on tire size.*

### To Change Speed Range

To adjust how fast the machine will travel in Speed Ranges 1 or 2, refer to “Machine Display” provided in the *Cab Section* elsewhere in this manual for further information.

### Shift Up/Down Switches

Speed ranges are selected by pressing the Shift Up/Down Switches (located on the side of the Hydrostatic Drive Control Handle).

- Press the Shift Up Switch to INCREASE speed range.
- Press the Shift Down Switch to DECREASE speed range.

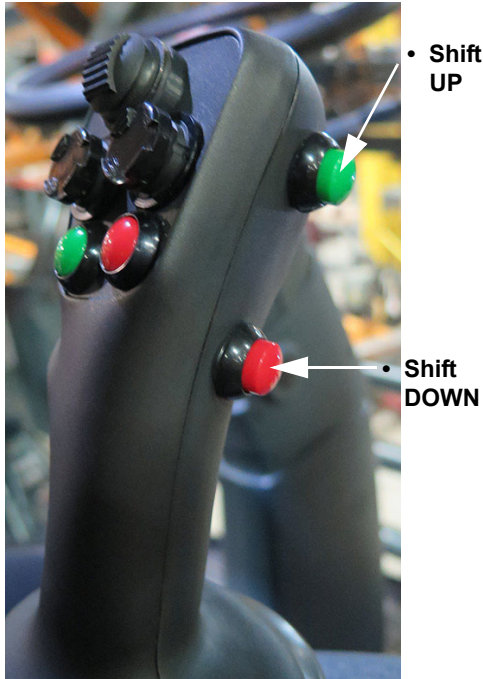

Shift Up/Down Switches  
(Located on the side of the  
Hydrostatic Drive Control Handle)  
-Typical View

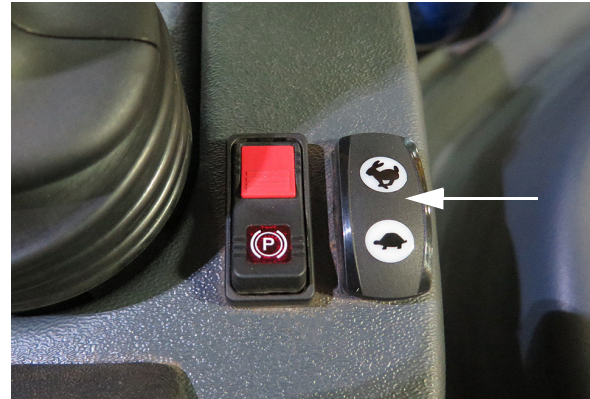

Throttle Switch  
(Located near the Hydrostatic  
Drive Control Handle)  
-Typical View

*NOTE: Engine speed can range between 850 and 2500 RPM in both Road and Field Mode.*

The Throttle Switch works with a timer to tell the engine how fast to run. The longer the operator holds the switch in either direction (press UP/"rabbit icon" to increase the speed, press DOWN/"turtle icon" to decrease the speed), the more the engine will speed up or slow down.

## Throttle Switch

The Throttle Switch (located near the Hydrostatic Drive Control Handle) is used to control engine speed (RPM).

*NOTE: The operator may select throttle setting by operating the Throttle Switch. However, engine speed is also controlled by movement of the Hydrostatic Drive Control Handle.*

## To Change Throttle Setting Values

Refer to "Machine Display" provided in the *Cab Section* elsewhere in this manual for information.

## Drive System Control

### **WARNING**

Ensure the back-up alarm is audible when operating the machine in reverse.

*NOTE: The NEUTRAL position must be met before changing the direction of the machine.*

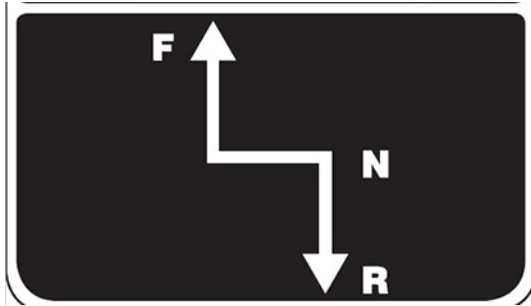

- **To move the machine forward**, slowly push the Hydrostatic Drive Control Handle FORWARD.

*NOTE: The further the handle is moved forward, the faster the machine will travel and the engine speed will increase.*

- **To move the machine in reverse**, slowly pull the Hydrostatic Drive Control Handle backward.

*NOTE: Machine speed is limited to 9 mph (14.5 km/h) when in reverse.*

*NOTE: The farther back the handle is pulled, the faster the machine's speed.*

- **To stop the machine**, slowly place the Hydrostatic Drive Control Handle in the NEUTRAL position.

*NOTE: Before turning the engine off, reduce the engine speed and allow to idle for a minimum of three (3) minutes.*

## NOTICE

The operator can choose a minimum level above 850 RPMs of engine speed that they want to operate the machine with by using the Throttle Switch.

## ALL-WHEEL STEER (AWS)

-If Equipped

**^ Operator's with machines equipped with AWS pay special attention!**

## NOTICE

Become familiar with the machine in both coordinated and conventional steering modes before attempting to use the machine for its intended use. ^

*NOTE: Read the following AWS information thoroughly and understand the operating instructions and safety precautions before operating.*



Hagie Manufacturing Company recommends becoming familiar with and understanding how to operate your machine in conventional steering mode before operating AWS. Understand AWS system components, operating procedures, and system limitations before operating.

The term "coordinated steering" is used to describe the AWS feature. Coordinated steering is when the front wheels turn one direction and the rear wheels turn in the opposite direction to create a tighter turn angle, which allow the rear wheels to follow the front wheel tracks. Operating your machine in AWS mode makes turning more efficient by minimizing crop damage and ground disturbance.

Ensure you are comfortable driving the machine on the road and in the field, with the booms in the transport and spray positions, as well as performing a variety of different turning scenarios before attempting to operate AWS.

## Progressive AWS

Hagie Manufacturing Company's Progressive AWS takes the original design and increases the active speed range while maintaining a safe turning radius. This is done by limiting how far the rear wheels will turn at higher speeds. The improvement allows operators to follow contours in the field and leave only one set of wheel tracks. This also allows them to make wide turns on end rows with only one set of wheel tracks.

Your rear wheels will track the front wheels, with limitations on speed and turning percentage. This is completely variable, so if you accelerate in a turn, your match on the rear will slowly come out. This feature keeps the machine safe when turning.

*NOTE: If you want to match all the time, decrease your speed or make a less drastic turn.*

*NOTE: AWS is disabled when Auto Steer is activated.*

## Terminology

### Conventional Steering

- Only the front wheels turn.

### Coordinated Steering ^

- All the wheels turn and do so where the rear tires follow in the front tires' tracks.

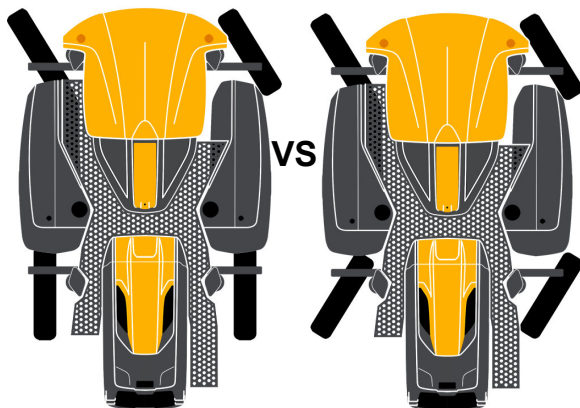

## AWS Components

The Steering Cylinder (internal position) and External Proximity Sensors are used to track cylinder rod extension.

## Steering Cylinders

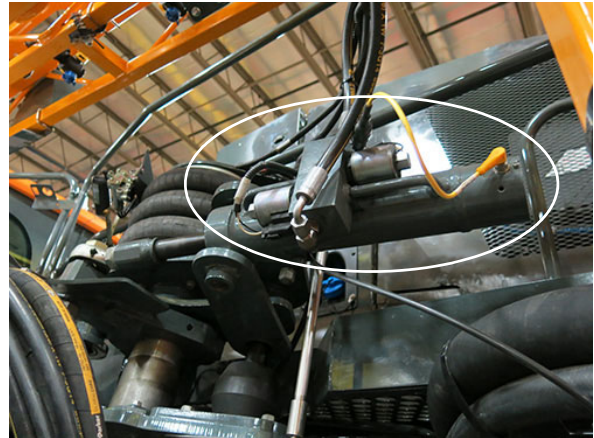

Steering Cylinder  
(Located on the rear legs)  
-Typical View

## External Proximity Sensors

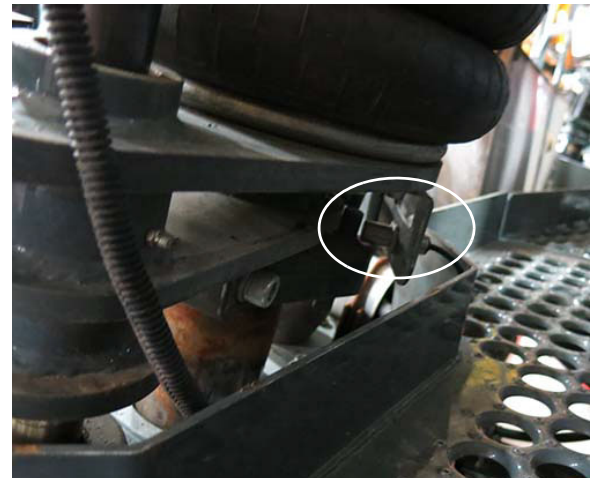

External Proximity Sensor  
-Typical View

## Lock Valves

Each rear cylinder is equipped with two (2) Lock Valves, which lock the cylinders into position when in Road mode and when the machine is not moving in Field mode.



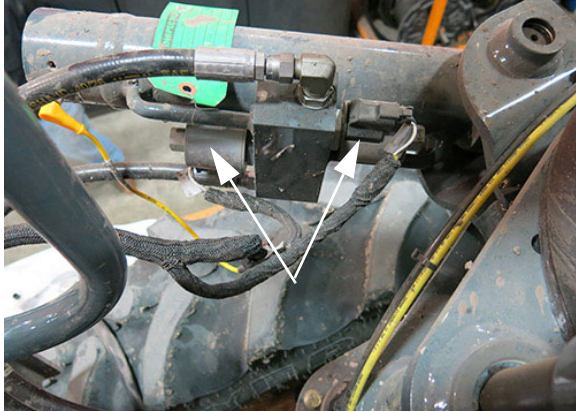

Lock Valves  
-Typical View

### Valve Manifold

Rear hydraulic steering is controlled by a Valve Manifold (located on the underside of the machine).



Valve Manifold  
(Located on the underside of machine)  
-Typical View

### Operating AWS

All conditions must be met before AWS will activate. First, the machine must be in Field mode, and second, machine speed must be less than AWS Shutoff Speed. If these conditions are not met, the AWS Button will remain ON, but the AWS indicator will turn OFF, and the machine will be operating in conventional steering mode.

When conditions are met again, AWS will automatically activate and the AWS indicator will illuminate.

*NOTE: The machine will automatically determine if the proper conditions have been met and change the status of the drive functions.*

1. Ensure the machine's drive state is in Field mode.
2. Press the AWS Button (located on the Machine Display Home Page - Field Mode) to the ON (illuminated) position.

• AWS Button

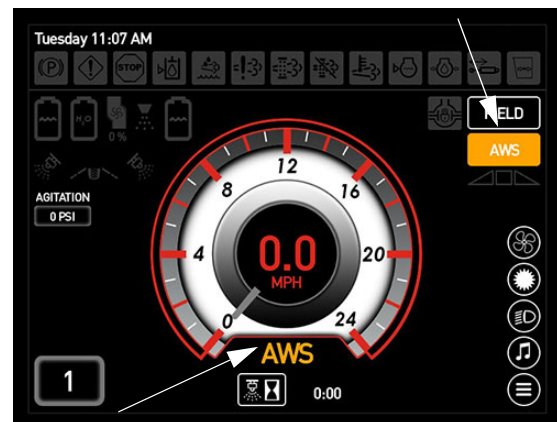

• AWS Indicator

An AWS indicator (located below the speedometer) will illuminate when AWS is activated (requiring all conditions to be met).

### AWS Shutoff Speed

Refer to “Machine Display” provided in the *Cab Section* elsewhere in this manual for further information.

### Limitations

- Machine speed is greater than AWS Shut-off Speed.

*NOTE: There is no warning message associated with this. The machine will automatically switch to conventional steering mode.*

- The machine's drive state must be in Field mode. If the machine is in Road mode, AWS is disabled (and the rear cylinder Lock Valves are locked).

## SECTION 4 – ENGINE AND DRIVE SYSTEMS



- System Fault - The system is not working properly (e.g. sensor malfunction, hydraulic malfunction, etc.)

*NOTE: A warning message will appear on the Machine Display and the machine may be limited on speed and other functions.*

- **Auto Steer Machines Only:**  
When the Auto Steer System is engaged, it will automatically turn the AWS System OFF and move the rear wheels back to straight.

### Recommendations for Best Operating Practices

- Apply the Decel Pedal (located to the lower right-hand side of the steering column) to decrease speed at end rows.

*NOTE: The Decel Pedal is NOT a brake! It is designated for speed reduction only.*

- Speed ranges are selected by pressing the Shift Up/Down Switches (located on the side of the Hydrostatic Drive Control Handle).
- Use the Hydrostatic Drive Control Handle to slow down more if needed. If you move the Hydrostatic Drive Control Handle first and then shift down to get to AWS mode, you will notice that the machine may slow down more than you wanted it to.
- Understand how the machine feels when it is still in a turn and is shifted up or down. The machine will still operate at whatever turn angle that you want to shift out at, but you may feel that this situation is causing an operation that you may not want (possibly getting the machine off the line intended because the rear wheels move back to straight position and the total turning radius will change).

In the following illustration, the two circles represent a full turn with AWS on. The - - - - lines represent the direction the operator wants the front tracks to go (assuming the operator wants to pull the machine back into rows that are running straight up and down.)

The - - - - - lines represent the direction that the front wheels are pointed when the operator shifts out of AWS speed range. If this occurs, the rear wheels will shift back to the straight position and the machine will no longer have the two tire tracks (two circles). The rear wheels will begin to follow the - - - - - path during this shift.

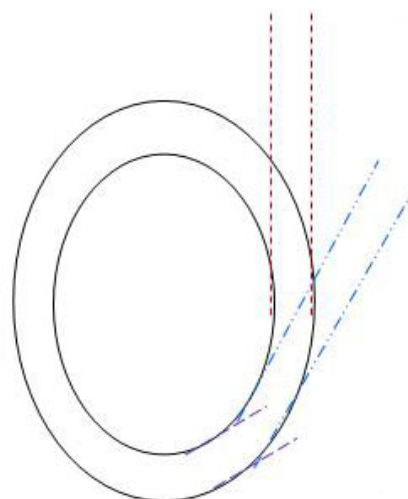

Hagie Manufacturing Company once again strongly recommends trying out and getting a feel for the AWS System before going straight to the field so you can get an understanding of what to expect. Some situations to try include:

- Driving the machine with both empty and a full solution tanks with AWS on.
- Drive the machine on hills, ensuring to take the proper precautions as stated in the *Safety and Precautions Section* elsewhere in this manual.
- Drive the machine at different turn angles and speeds to see how the limitations work.

*NOTE: You will notice that if you go over any of the limitations, you can slow back down and the AWS system will automatically turn itself back on.*

- **Auto Steer Machines Only:**  
Notice how the machine feels when in AWS mode and switching from Auto Steer ON to OFF, especially when turning.
- Contact your local John Deere dealer with any questions you may have

regarding the operation of the AWS System.



## SECTION 5 – HYDRAULIC SYSTEMS

### HYDRAULIC SYSTEM COMPONENTS

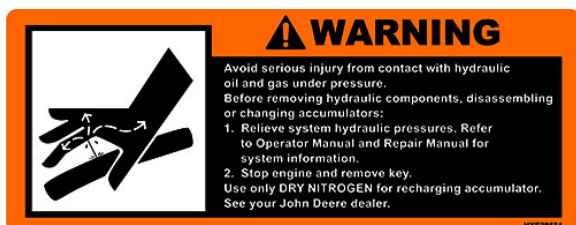

### Hydraulic Pumps (Mounted to the engine)

- Gear Pump
- Pressure Compensated (PC) Pump
- Drive Pump

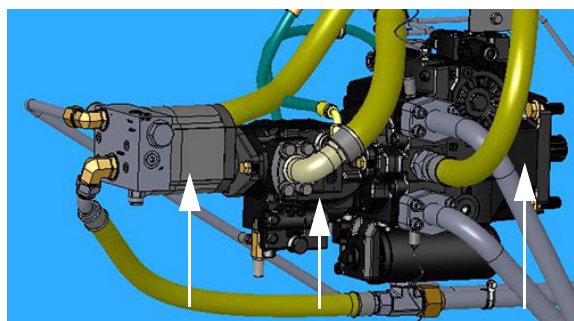

- Gear Pump
- PC Pump
- Drive Pump

Hydraulic Pumps  
-Typical View

The three Hydraulic Pumps (mounted to the engine) circulate hydraulic oil throughout the necessary systems and back through the oil cooler before returning it to the reservoir.

### NOTICE

Operating the machine without adequate hydraulic oil level will result in system damage and will void the warranty.

If hydraulic oil level is too low for safe operation, a warning message will appear on the Machine Display to alert you of low hydraulic oil level. Press OK to acknowledge, shut down the engine immediately, and refill reservoir to proper level to avoid damage to the hydraulic systems.

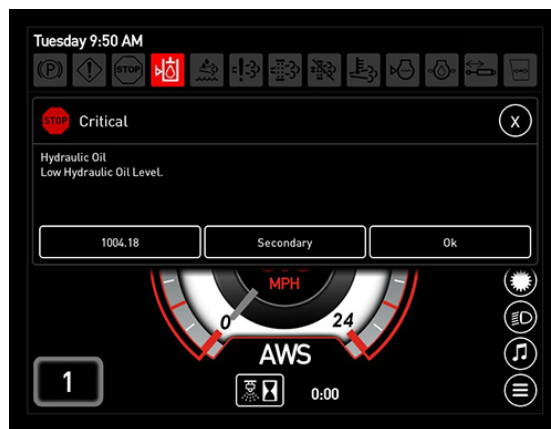

Low Hydraulic Oil Level Warning Message  
(Located on the Machine Display)

### Gear Pump

(With Proportional Flow Control)

The Gear Pump powers the solution pump.

### PC Pump

The PC Pump powers the high-pressure filter, power steering, spray booms, tread adjustment valve (if equipped), AWS valve (if equipped), and the variable pitch fan (if equipped).

### Drive Pump

The Drive Pump powers the wheel motors.

### Hydraulic Filtering/Cooling Components

- Oil Cooler
- Hydraulic Oil Reservoir
- Return Filter
- Pressure Filter
- Tank Breather Cap

- Level/Temp Sensor

*NOTE: Refer to the Maintenance and Storage Section elsewhere in this manual for information on filling the hydraulic oil reservoir and replacing hydraulic filters.*

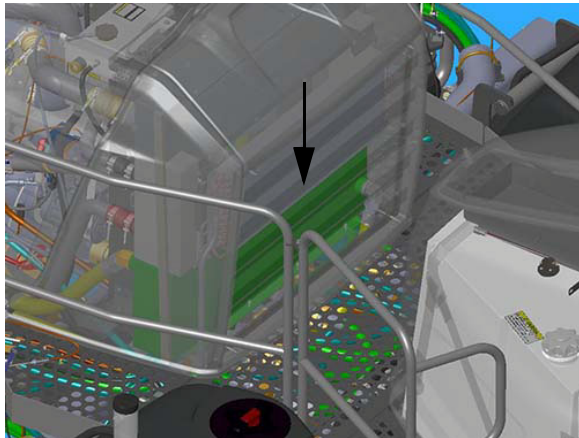

**Oil Cooler**  
(Located in front of engine -  
remove radiator screen -  
-Typical View

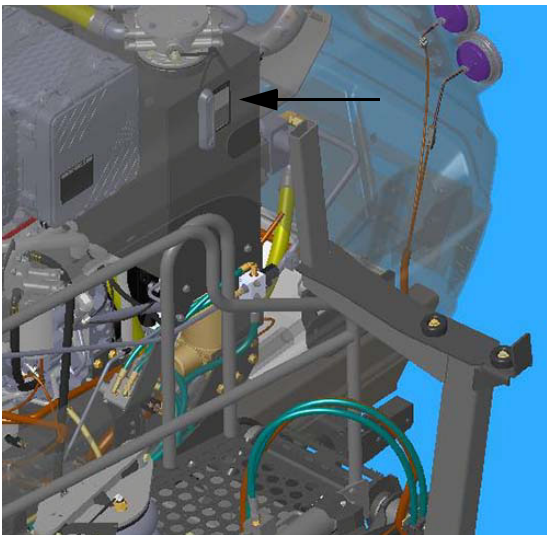

**Hydraulic Oil Reservoir**  
(Located near rear left-hand side  
of machine - open hood to access)  
-Typical View



**Return Filter**  
(Located inside filter housing on top of  
hydraulic oil reservoir - open hood to access)  
-Typical View

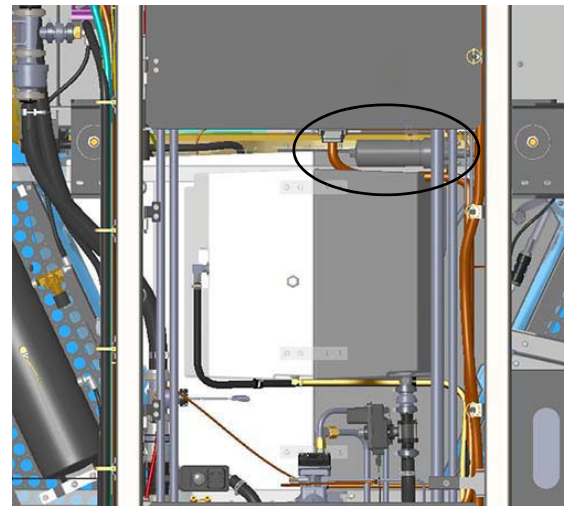

**Pressure Filter**  
(Located beneath front  
left-hand side of machine)  
-Typical View

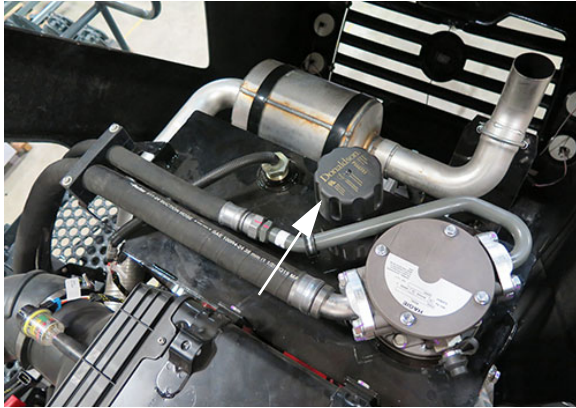

**Tank Breather Cap**  
(Located on top of hydraulic oil reservoir - open hood to access)  
-Typical View

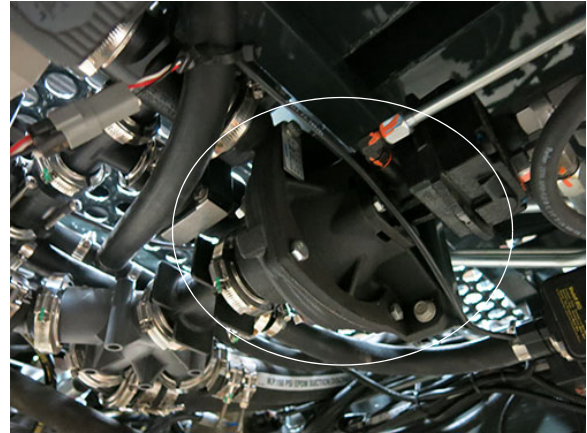

**Solution Pump**  
(Located beneath center of machine)  
-Typical View

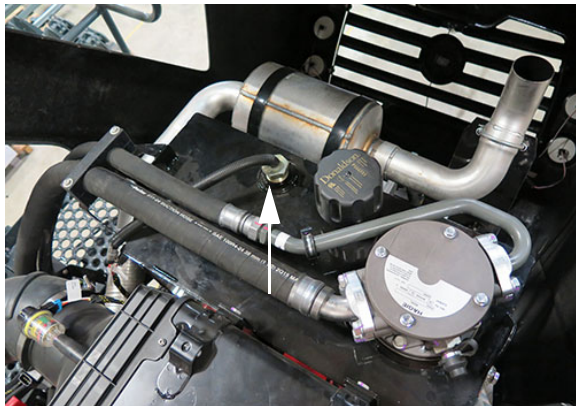

**Level/Temp Sensor**  
(Located on top of hydraulic oil reservoir)  
-Typical View

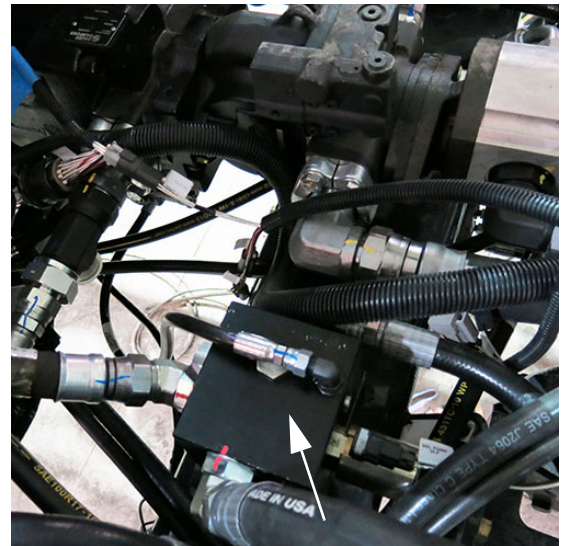

**Solution Pump Control Manifold**  
(Located near center of machine)  
-Typical View

### **Hydraulic Spray System Components**

- Solution Pump
- Solution Pump Control Manifold
- Lift/Level Control Manifold\*
- Fold Control Manifold

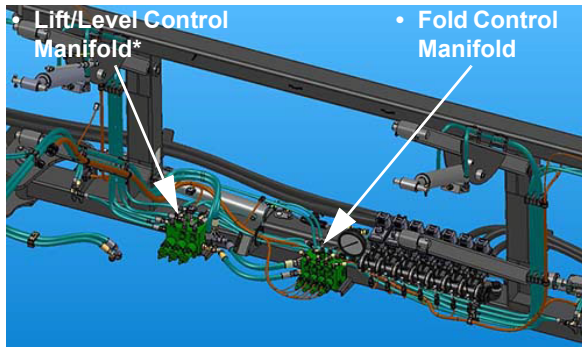

Lift/Level and Fold Control Manifolds  
(Located on center transom)  
-Typical View

\* Used in conjunction with NORAC®  
auto boom height - *if equipped*

Refer to the *Spray Systems Section* elsewhere in this manual for further information.

## REVERSIBLE FAN - VARIABLE PITCH

*NOTE: If your machine is equipped with the Viscous Clutch Fan, refer to the Miscellaneous Section elsewhere in this manual for further information.*

### **WARNING**

Improper operation, maintenance, or repair of this product can be dangerous and may result in serious injury or death.

- Always use Hagie-approved parts and components. Failure to comply will result in voiding the 1-year parts warranty.
- Do not operate or perform any service on this product until you have read and understand the operation and maintenance information. Contact your local John Deere dealer for any additional information that you may require.
- The person(s) servicing the product may be unfamiliar with many of the systems or components of the product. Use caution when performing service. Knowledge of the product and components are important before the removal or disassembly of any component.

### **WARNING**

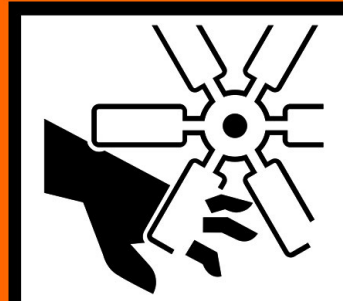

**Avoid rotating fan.  
Stop engine.  
Keep clear to avoid  
serious injury.**

T188283

### **NOTICE**

The fan system reduces power and fuel consumption of the engine when full airflow is not required to keep the engine cool.

## SECTION 5 – HYDRAULIC SYSTEMS



The Reversible Fan is a hydraulically-controlled variable pitch fan capable of rotating the fan blades to reduce or reverse air flow. It is mounted to the engine and uses hydraulic pressure to rotate the fan blades to change the pitch and increase/decrease airflow through the cooling pack as needed. The fan is controlled by an Electronic Control Unit (ECU) based off of temperature sensors from the cooling system.

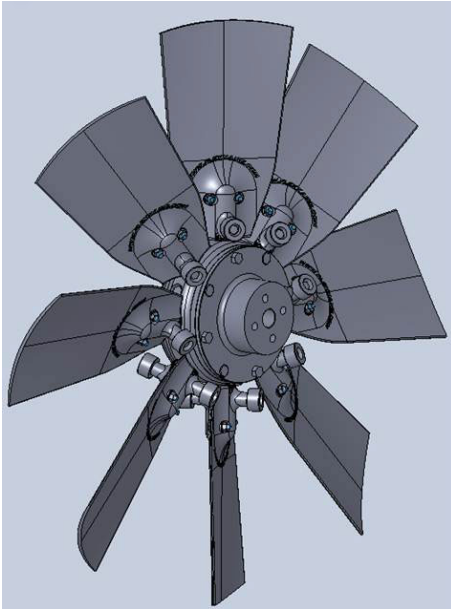

Variable Pitch Fan  
(Located near the rear of machine  
- open hood to access)  
-Typical View

### To Activate the Reversible Fan

Refer to “Machine Display” provided in the *Cab Section* elsewhere in this manual for complete operating instructions.

### Before Starting the Engine

1. Ensure all hoses and wires are adequately secured and routed away from the fan operating area.
2. Ensure all tools have been removed from the engine compartment, including the top side of the radiator and inside of the shroud before the fan guards are installed. Obstacles in the path of rotation can interfere with movement of the

- fan and can result in damage to the fan blades, fan hub, and radiator core.
3. Inspect the radiator shroud mounting bolts to ensure that the radiator and shroud are firmly secured and unable to move during operation of the machine. Loose shroud bolts can allow the fan shroud to move into the path of the rotating blades and loose radiator mounting bolts can allow the radiator to flex in position, allowing the shroud to come into contact with the rotating fan blades.
4. Ensure all fan guards have been installed and firmly secured into place. The Reversible Fan creates an abundant amount of airflow in both cooling and cleaning mode operation. The result of this airflow is a strong vacuum effect that can suck in items that are located inside or around the engine compartment fan.
5. To ensure maximum efficiency, start with a clean cooling system free of debris, paying particular attention to the stacked cooler core(s).

### Service and Maintenance

#### **WARNING**

Ensure the Battery Disconnect Switch is OFF before performing any service on the fan. Failure to comply may result in engine turnover, serious injury, or death.

Under normal operating conditions, the Reversible Fan does not require scheduled maintenance (other than lubrication) and is built to provide thousands of hours of trouble-free service.

In moderate to extreme operating conditions, a visual inspection of moving parts is recommended from time to time to safeguard against fan blade damage, which could lead to equipment and/or other damage.



## TREAD ADJUSTMENT - HYDRAULIC

### -If Equipped

*NOTE: Refer to the Miscellaneous Section elsewhere in this manual for information on adjusting Manual Tread Width (if equipped).*

Your machine may be equipped with Hydraulic Tread Adjust to boost capability and perform applications for various field row widths and cropping stages with minimal crop damage.

### Tread Range

- Minimum Tread Width = 120" (304.8 cm)\*
- Maximum Tread Width = 160" (406.4 cm)\*

\* Depending on tire size.

### To Adjust Tread Width

**⚠ CAUTION**

Never adjust hydraulic tread width on a public roadway. Ensure the machine is on level ground where there are no ditches or valleys to interfere while you perform the adjustment.

**NOTICE**

Never adjust tires wider than 160"/406.4 cm (center-to-center). Failure to comply may result in leg damage.

**NOTICE**

Survey your surroundings and allow yourself enough room to adjust tread width in either forward or reverse.

**NOTICE**

The machine must be in motion while adjusting tread width. Failure to comply may result in machine damage.

**NOTICE**

The machine's drive state must be in FIELD MODE before adjusting tread width.

1. Ensure the Tread Adjust Slide Path (located on each leg) has an adequately lubricated surface to slide along during adjustment.

*NOTE: Refer to "Service - Lubrication" provided in the Maintenance and Storage Section elsewhere in this manual for further information.*

2. Survey your surroundings and allow yourself enough room to adjust the tread in either forward or reverse.
3. Press the Tread Button (located on the Machine Display Main Menu) to navigate to the "Tread Width Adjustments" screen.

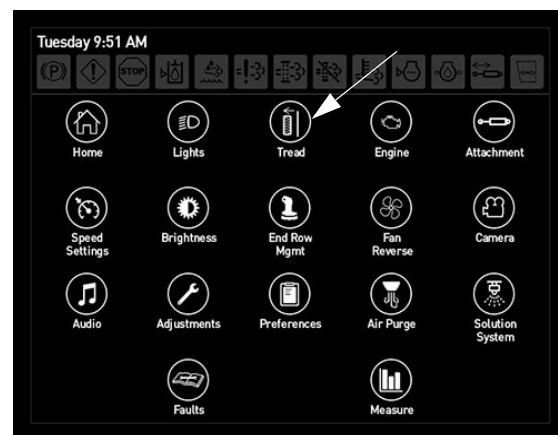

Tread Button  
(Located on the Machine Display Main Menu)

## SECTION 5 – HYDRAULIC SYSTEMS



- While driving one or two miles per hour (1.6 to 3.2 km/h), press and hold the desired Left or Right Tread Adjustment Button (located on the Machine Display “Tread Width Adjustments” screen) to move tread in or out as desired.

**NOTE:** Both front and rear tread will extend/retract when the corresponding Left and Right Tread Adjustment Buttons are pressed. However, if precise balance is desired, individual tread adjustment is recommended.



Tread Adjust Indicator  
-Typical View

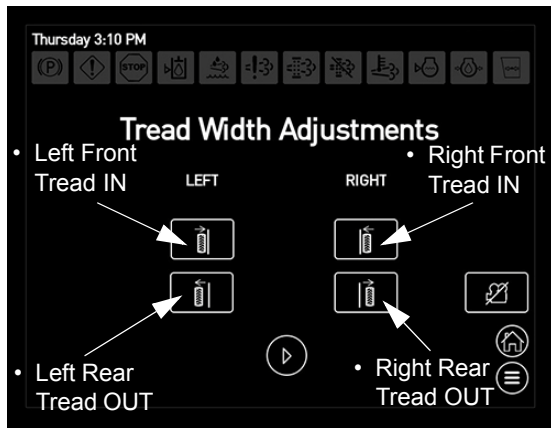

Left/Right Tread Adjustment Buttons  
(Located on the Machine Display  
Tread Width Adjustments Screen)

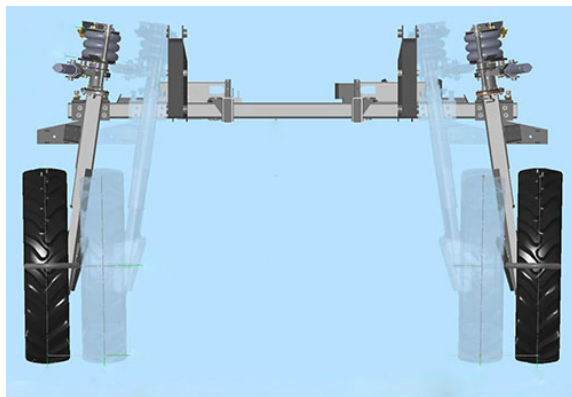

- Observe the corresponding Tread Adjust Indicator (located on the legs).

- Release the Tread Adjustment Button when desired tread width is achieved.

### To Adjust Individual Tread Width

- Press the Next Button (located on the Machine Display “Tread Width Adjustments” screen) to navigate to the “Individual Tread” screen.

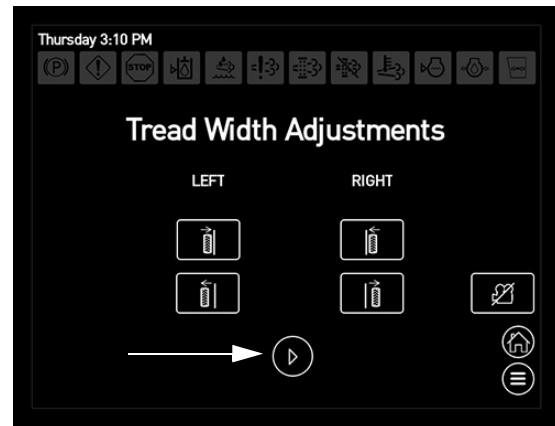

Next Button  
(Located on the Machine Display  
Tread Width Adjustments Screen)

- On the “Individual Tread” screen, select the tread that you wish to individually adjust by pressing the desired “wheel(s)” on the display screen.

**NOTE:** You may also select all four (4) “wheels” to adjust all four tread widths simultaneously.

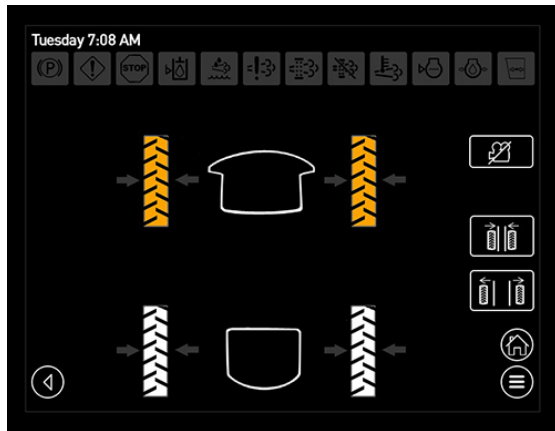

Individual Tread Screen

3. Survey your surroundings and allow yourself enough room to adjust the tread in either forward or reverse.
4. While driving one or two miles per hour (1.6 to 3.2 km/h), press and hold the Tread In or Out Button until desired tread width is obtained.

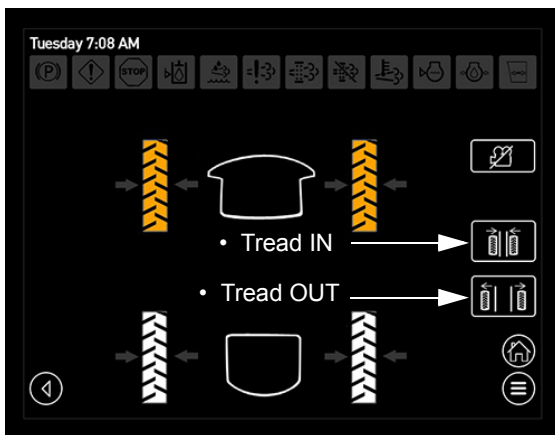

Tread In/Out Buttons  
(Located on the Individual Tread Screen)

5. Observe the corresponding Tread Adjust Indicator (located on the legs).



Tread Adjust Indicator  
-Typical View

6. Release the Tread In or Out Button when desired tread width is achieved.

*NOTE: The Tread In/Out Button(s) may only be held for 9 seconds. Exceeding 9 seconds will require the button(s) to be repressed.*

### Rear-view Camera Activation While Adjusting Tread Width

A Rear-view Camera Activation Button is located on both the “Tread Width Adjustments” screen and the “Individual Tread” screen to allow the operator to turn the rear-view camera on/off directly from the tread screens.

- Press the Rear-view Camera Activation Button in the illuminated position to turn rear-view camera OFF. Press button again to turn rear-view camera ON.

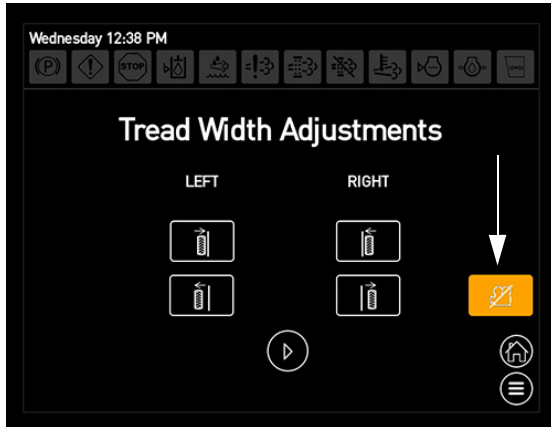

Rear-view Camera Activation Button  
(Located on the Tread Width Adjustments  
Screen and Individual Tread Screen)  
- Deactivated (illuminated) position shown

## LADDER

### IMPORTANT

If the operator is out of the seat with the Hydrostatic Drive Control Handle in neutral for five (5) seconds, the Parking Brake will engage, the ladder will lower, and the parking brake indicator on the Machine Display will illuminate.

To Disengage the Parking Brake:

1. The operator must be seated in the operator's seat.
2. Ensure the Hydrostatic Drive Control Handle is in the NEUTRAL position.
3. Toggle the Parking Brake Switch on, then off again.

### CAUTION

Upright ladder is not a service platform or step.

- DO NOT step on the ladder while in the upright position.
- DO NOT lower the ladder while anyone is on the ground near the machine.
- DO NOT attempt to lower the ladder from ground level.

Failure to comply may result in injury.

### To Lower the Ladder

### CAUTION

Ensure the Hydrostatic Drive Control Handle is in the NEUTRAL position before engaging the parking brake. Failure to comply may result in personal injury and/or machine damage.

- **To lower the Ladder**, move the Hydrostatic Drive Control Handle to the NEUTRAL position.

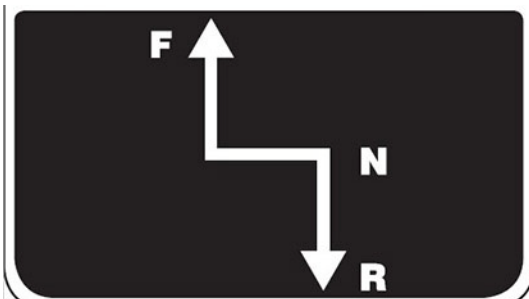

Hydrostatic Drive Control Handle  
-Typical View

- Slide the red safety lever (located on the Parking Brake Switch) DOWN (Back) and press top of switch DOWN.

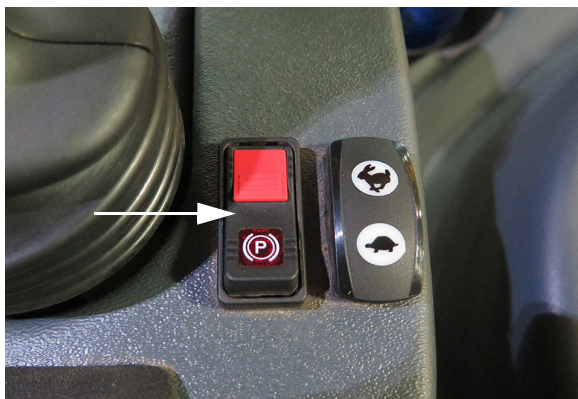

Parking Brake Switch  
(Located near the Hydrostatic  
Drive Control Handle)  
-Typical View



Ladder  
-Typical View  
\* Lowered position shown

*NOTE: When the Parking Brake is engaged, a parking brake indicator (located on the top left-hand side of each Machine Display page) and the Parking Brake Switch will illuminate.*

### To Raise the Ladder

- **To raise the Ladder**, press the Parking Brake Switch in the DOWN (Off) position.

*NOTE: When the Ladder is raised, the Parking Brake will be OFF (disengaged).*

## PRESSURE WASHER

### -If Equipped

*NOTE: The Parking Brake must be engaged before operating the Pressure Washer.*

## **⚠ CAUTION**

Pressurized water can be abrasive.

- Never point the spray wand at persons or any part of the human body.
- Never directly spray fragile or sensitive materials.

Failure to comply may result in personal injury or property damage.

**⚠ CAUTION**

Never tie open the spray wand trigger or start the machine with the spray wand unattended. High-pressure flow may cause the spray wand to become a projectile hazard, resulting in personal injury or property damage.

**⚠ CAUTION**

Wear goggles or a face shield to protect eyes from spray, chemicals, or back-spattered material while operating the pressure washer.

**NOTICE**

Never use the pressure washer to spray items under the hood. Failure to comply may result in engine and other component damage and will void the warranty.

**NOTICE**

Never run the pressure washer without water supply. Operating without water will cause pump failure and will void the warranty.

*NOTE: Inspect the pressure washer hose daily for cuts or abrasions.*

**To Operate the Pressure Washer**

1. Ensure there is adequate amount of water in the rinse tank.
2. Ensure the Pressure Washer wand and hose are securely connected.

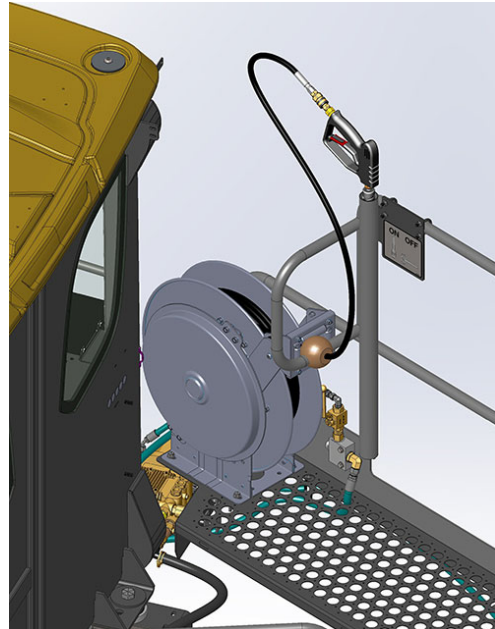

Pressure Washer Wand and Hose Reel  
(Located behind right-hand side of cab)  
-Typical View

3. Ensure the Hydrostatic Drive Control Handle is in the NEUTRAL position and parking brake is engaged.
4. Start the engine.
5. Activate the Pressure Washer Pump (located beneath the front right-hand platform) by rotating the Pressure Washer Hand Valve (located behind the right-hand side of cab) in the “counter-clockwise” (ON) position.

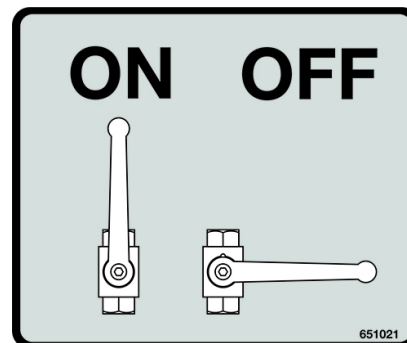

**Pump Maintenance**

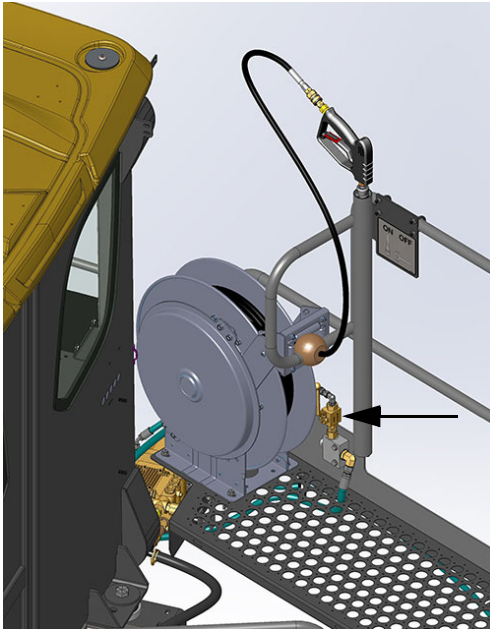

Pressure Washer Hand Valve  
(Located behind right-hand side of cab)  
-Typical View

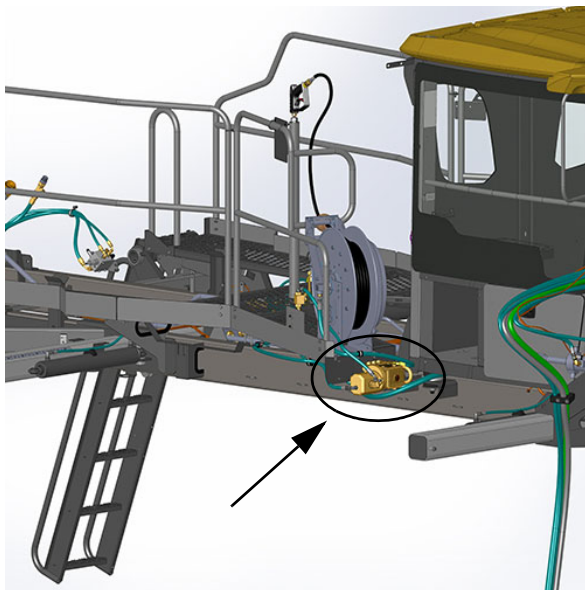

Pressure Washer Pump  
(Located beneath front right-hand platform)  
-Typical View

**NOTICE**

Do not run acids, petroleum-based solvents, highly chlorinated materials, or insecticides through the pressure washer pump. Failure to comply may result in internal component damage. Use only detergents formulated for use with pressure washers and follow the manufacturer's instructions for use.

- Check pressure washer pump oil level daily. "Top off" as required.
- Change the pressure washer pump oil every 200 hours of operation.
- 30-weight non-detergent oil recommended.

**Further Information**

Refer to the manufacturer's information for safety precautions, maintenance and storage information, and troubleshooting tips.

6. The Pressure Washer is now ready for use. Extend hose as desired.
7. **When finished**, retract hose and rotate the Pressure Washer Hand Valve in the "clockwise" (OFF) position.



## SECTION 6 – ELECTRICAL SYSTEMS

### BATTERIES

#### **⚠ WARNING**

Battery posts, terminals, and related accessories contain lead and lead compounds, chemicals known to the State of California to cause cancer and reproductive harm. Wash hands after handling.

#### **⚠ CAUTION**

Batteries contain sulfuric acid. Avoid contact with skin, eyes, or clothing. Do not inhale fumes or ingest liquid. Batteries contain gases which can explode. Keep sparks and flame away while servicing.

#### **⚠ CAUTION**

Disconnect the battery when servicing any part of the electrical system. Failure to comply may result in injury and property damage.

#### **Access**

The batteries are located on the rear right-hand side of machine.

*NOTE: When servicing the electrical system, always remove the batteries (removing the ground cable first). When reinstalling the batteries, connect the ground cable last.*

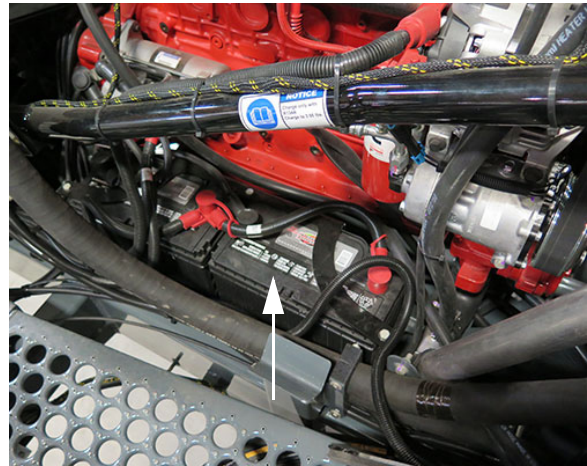

Batteries  
(Located on the rear  
right-hand side of machine)  
-Typical View

#### **Charging**

#### **⚠ CAUTION**

Electrical system is 12-volt negative ground. When using booster with jumper cables, precautions must be taken to prevent personal injury or damage to electrical parts.

1. Attach one end of jumper cable to positive booster terminal and other end to positive terminal of vehicle battery connected to starter motor.
2. Attach one end of second cable to negative booster terminal and other end to vehicle frame away from battery.
3. To remove cables, reverse above sequence exactly to avoid sparks. See operator's manual for additional information.

For your convenience, a set of Auxiliary Battery Charging Posts are located on the rear mainframe for ease of charging the batteries.



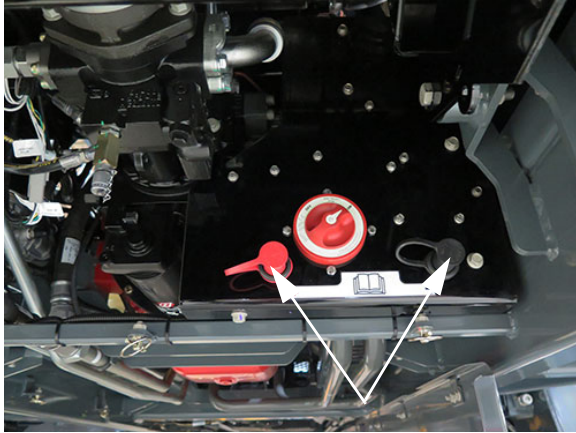

Auxiliary Battery Charging Posts  
(Located on the rear mainframe)  
-Typical View

Connect your charging cables to the Auxiliary Battery Charging Posts just as you would to the battery - positive cable to the positive terminal, and negative cable to the negative terminal.

*NOTE: Keep these terminals clean and their caps in place when not in use.*

## NOTICE

To ensure sufficient electrical contact, battery terminal connections should be as clean and tight as possible.

## Cleaning

- Disconnect the battery cables from the batteries.
- Remove any corrosion with a wire brush or battery post brush.
- Wash the battery cable connections and posts with a mild baking soda and ammonia solution.
- Apply grease (or dielectric grease) to prevent corrosion.
- Reconnect the batteries, ensuring connections are tight.
- Clean every 100 hours of operation.

## Replacement

Install replacement batteries with ratings equivalent to the following specifications:

- **Voltage** - 12V only
- **CCA** - 30 seconds at 0° F. (950)
- **Reserve Capacity** - 185 minutes at 25 amps

## Storage

Refer to “Storage” provided in the *Maintenance and Storage Section* elsewhere in this manual for further information.

## BATTERY DISCONNECT SWITCH

### **WARNING**

DO NOT use the Battery Disconnect Switch as a safety device when performing work to the electrical system. Disconnect the negative battery cable before servicing.

### **IMPORTANT**

- Do not bypass disconnect.
- Do not terminate electrical devices to battery terminals.
- Turn switch off before servicing electrical equipment.
- Completely isolate electronics before welding by disconnecting battery negative terminal.
- Rotate switch to “ON” position for operation.

Your machine is equipped with a Battery Disconnect Switch (located on the rear mainframe) to de-energize battery power, cutting all electrical power to the engine.

- Rotate the Battery Disconnect Switch to the ON (clockwise) or OFF (counter-clockwise) positions to operate.

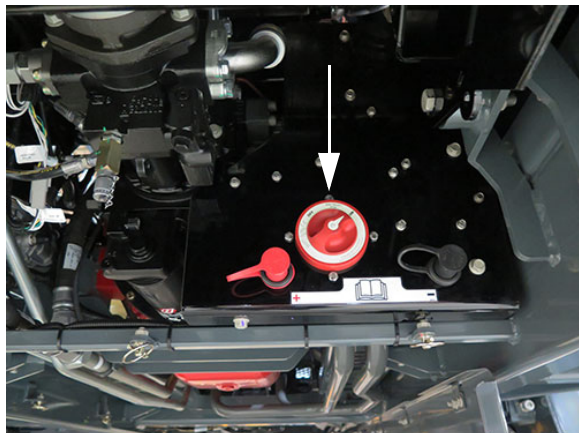

Battery Disconnect Switch  
(Located on the rear mainframe)  
-Typical View

*NOTE: Turn the Battery Disconnect Switch OFF during long storage periods.*

*NOTE: **Final Tier 4 Engines** - Allow the Diesel Exhaust Fluid (DEF) Recirculation Pump to finish running before turning the Battery Disconnect Switch off.*

**FUSES AND RELAYS**

**Interior Cab Functions**



Circuit Breakers/Fuses (Interior)  
(Located rear of side console -  
remove tray to access)  
-Typical View

The following label is affixed beneath the side console (remove tray to access) and provides information on component fuse/relay amperage ratings.

<p><b>Mini-Fuses</b>  F01 - HVAC Power (25A)  F02 - A-Post Gauges (5A)  F03 - Spray Section Keypad (5A)  F04 - Radio (10A)  F05 - Wiper/Washer (15A)  F06 - Aux Sw Pwr 1 (15A)  F07 - Pod Sw Pwr (5A)  F08 - Sw Pwr Signal (3A)  F09 - Chassis XA2-0 Pwr (20A)  F10 - Steering Column/Bat Pwr (20A)  F11 - Rotating Beacons (15A)  F12 - Attach Vlv Pwr 2 (20A)</p>	<p><b>Mini-Fuses</b>  F26 - EDP Bat Power (5A)  F27 - Ignition Key (10A)  F28 - Steering Column Pwr (15A)  F29 - Pod Bat Pwr (10A)  F30 - Power Outlets (20A)  F31 - Power Con 1 &amp; 2 Bat Pwr (20A)  F32 - Power Con 2 Sw Pwr (20A)  F33 - Aux Sw Pwr 2 (15A)  F34 - Seat Power (20A)  F35 - Aux Sw Pwr 3 (20A)  F36 - Pwr Con 1 Sw Pwr (20A)  F37 - SASA Kick-out (15A)</p>
<p>F13 - Chassis XA2-1 Pwr (20A)  F14 - Attach Vlv Pwr 1 (20A)  F15 - Attach Vlv Pwr 3 (20A)  F16 - Attach Mod Pwr 1 (20A)  F17 - Attach Mod Pwr 2 (20A)  F18 - Chas S-XA2-0 Pwr (20A)  F19 - Attach Mod Pwr 3 (20A)  F20 - Attach Mod Pwr 4 (20A)  F21 - Field Lights 1 (15A)  F22 - Aux Relay 1 (10A)  F23 - Field Lights 2 (15A)  F24 - Start Relay (10A)  F25 - Radio/Dome Bat Pwr (5A)</p> 	<p>F38 - PRI-Con Mod Pwr (20A)  F39 - SEC-Con Mod Pwr (20A)  F40 - HVAC Clutch (15A)</p> <p><b>Relays</b>  CR01 - Rotating Beacon Lights  CR02 - Wiper  CR03 - Wiper/Washer  CR04 - Field Lights 1  CR05 - Field Lights 2  CR06 - Start Relay  CR07 - Aux Relay 1  CR08 - SASA Kick-out</p> <p>292629 <span style="float: right;">32281-0 (LR-0)</span></p>

## SECTION 6 – ELECTRICAL SYSTEMS



### Exterior Lights/System Functions

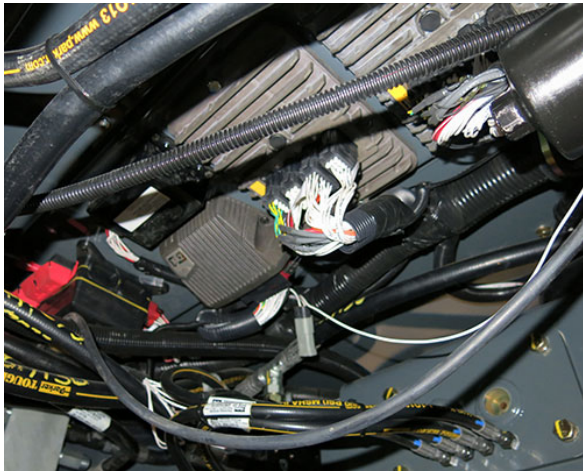

Circuit Breakers/Fuses (Exterior)  
(Located beneath cab -  
remove panel to access)  
-Typical View

The following label is affixed beneath the cab and provides information on component fuse/  
relay amperage ratings.

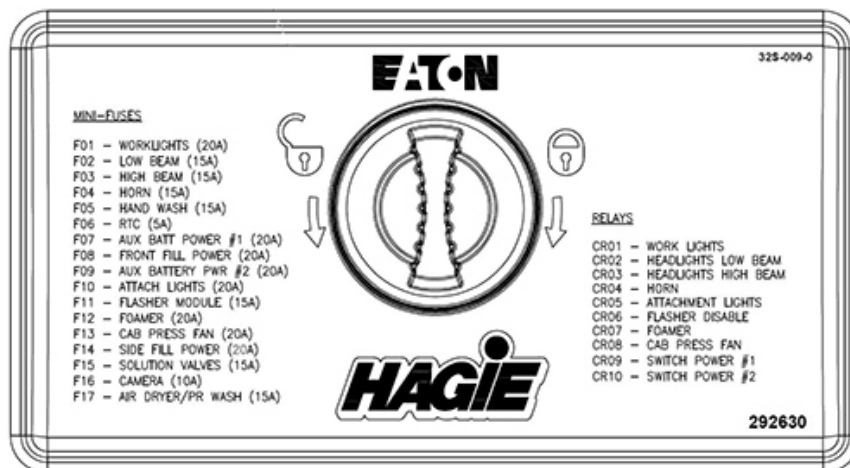

## Final Tier 4 Engine Fuses and Relays



Final Tier 4 Engine Fuse/Relay Block  
(Located beneath batteries on the rear right-hand side of machine)  
-Typical View

The following labels are affixed near the engine fuse/relay block and provide information on component fuse/relay amperage ratings.

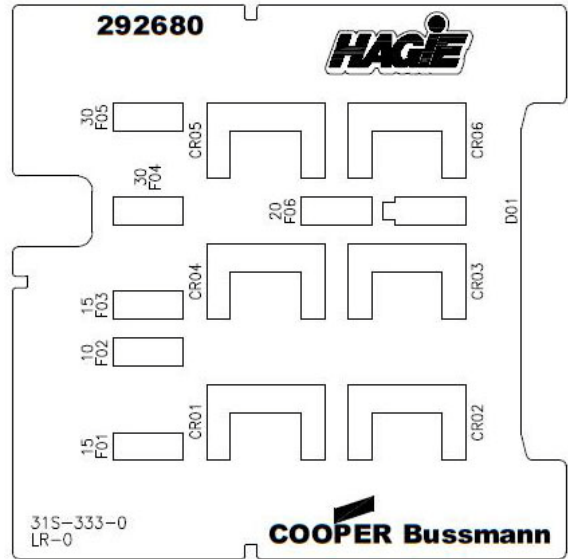
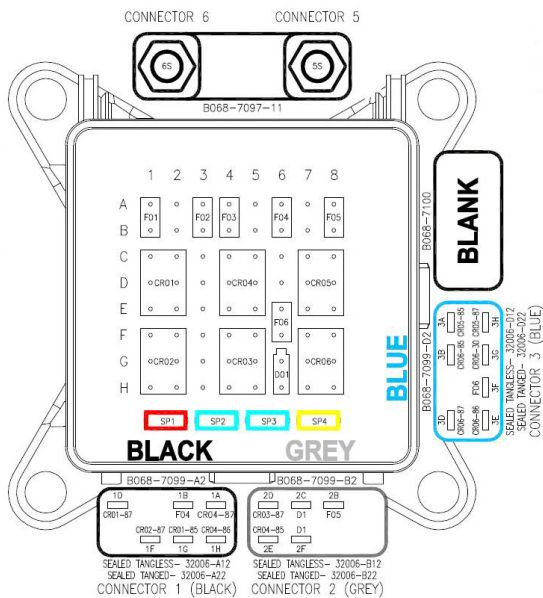

Device Placement			
Pos.	Ref.	Device	Part No.
D1	F01	Mini Fuse	ATM-15UNP-PEC
D2	F02	Mini Fuse	ATM-10UNP-PEC
D3	F03	Mini Fuse	ATM-15UNP-PEC
D4	F04	Mini Fuse	ATM-30UNP-PEC
D5	F05	Mini Fuse	ATM-30UNP-PEC
D6	R1	12V, 35A 5-Pin Micro	B120-7025
D7	R4	12V, 35A 5-Pin Micro	B120-7025
D8	R5	12V, 35A 5-Pin Micro	B120-7025
D9	F06	Mini Fuse	ATM-20UNP-PEC
D10	R2	12V, 35A 5-Pin Micro	B120-7025
D11	R3	12V, 35A 5-Pin Micro	B120-7025
D12	R6	12V, 35A 5-Pin Micro	B120-7025
D13	D01	6A Diode	22903-6V

# SECTION 6 – ELECTRICAL SYSTEMS



Spare Device Placement		
Position	Device	Part No.
SP1	Mini Fuse	ATM-10UNP-PEC
SP2	Mini Fuse	ATM-15UNP-PEC
SP3	Mini Fuse	ATM-20UNP-PEC
SP4	Mini Fuse	ATM-30UNP-PEC

Device Totals		
Device	Part No.	Amount
Mini Fuse	ATM-10UNP-PEC	2
Mini Fuse	ATM-15UNP-PEC	3
Mini Fuse	ATM-20UNP-PEC	2
Mini Fuse	ATM-30UNP-PEC	3
6A Diode	22903-6V	1
12V, 35A 5-Pin Micro	B120-7025	6

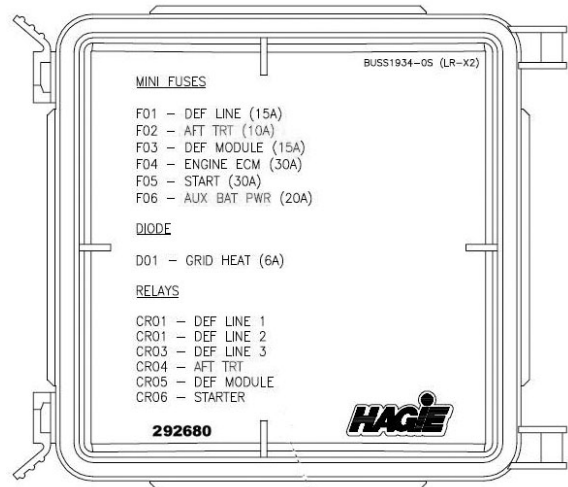

## Hood Actuator Fuse



**Hood Actuator Fuse**  
(Located beneath rear  
right-hand side of machine)  
-Typical View  
*Remove rear panel and brush curtain  
to access if equipped with Tall Crop Package*

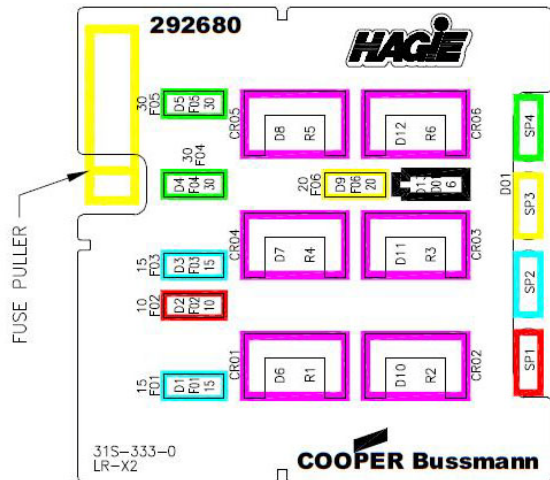

**FUSE AND RELAY RATINGS**

<b>Fuses and Relays - Exterior (Located beneath cab) <i>* Remove panel to access</i></b>		
<b>Fuse</b>	<b>Rating (Amps)</b>	<b>Function</b>
F01	20	Work Lights
F02	15	Highway Lights (Low Beam)
F03	15	Highway Lights (High Beam)
F04	15	Horn
F05	15	Hand Wash
F06	5	RTC Battery Power
F07	20	Auxiliary Battery Power 1
F08	20	Front Fill
F09	20	Auxiliary Battery Power 2
F10	20	Attachment Lights
F11	15	Flasher Module
F12	20	Foam Marker
F13	20	Cab Pressure Fan
F15	15	Solution Valves
F16	10	Camera
F17	15	Air Dryer
<b>Relay</b>	<b>Rating (Amps)</b>	<b>Function</b>
CR01	35	Work Lights
CR02	35	Headlights (Low Beam)
CR03	35	Headlights (High Beam)
CR04	35	Horn
CR05	35	Attachment Lights
CR06	35	Flasher Disable
CR07	35	Foam Marker
CR08	35	Cab Pressure Fan
CR09	35	Switch Power 1
CR10	35	Switch Power 2

**SECTION 6 –  
ELECTRICAL SYSTEMS**



<b>Fuses and Relays - Interior</b> <b>(Located rear of side console)</b> <i>* Remove tray to access</i>		
<b>Fuse</b>	<b>Rating (Amps)</b>	<b>Function</b>
F01	25	HVAC Power
F02	5	A-Post Gauges
F03	5	Boom Solution Valves (Spray Section Keypad)
F04	10	Radio Power
F05	15	Wiper/Washer Power
F06	15	Auxiliary Switched Power 1
F07	5	Pod Switched Power
F08	3	Power Mirrors/Power Signal for Auxiliary Switched Power (beneath cab)
F09	20	Chassis XA2-0 Power
F10	20	Steering Column/Battery Power
F11	15	Rotating Beacons
F12	20	Attachment Valve Power 2
F13	20	Chassis XA2-1 Power
F14	20	Attachment Valve Power 1
F15	20	Attachment Valve Power 3
F16	20	Attachment Module 1 Power
F17	20	Attachment Module 2 Power
F18	20	Chassis S-XA2-0 Power
F19	20	Attachment Module 3 Power
F20	20	Attachment Module 4 Power
F21	15	Field Lights 1
F22	10	Auxiliary Relay 1
F23	15	Field Lights 2
F24	10	Start Relay
F25	5	Radio/Dome Light
F26	5	EDP Battery Power
F27	10	Ignition Key
F28	15	Steering Column Power





**SECTION 6 –  
ELECTRICAL SYSTEMS**

F29	10	Pod Battery Power
F30	20	Power Outlets
F31	20	Power Connector 1 and 2 Battery Power
F32	20	Power Connector 2/Switched Power
F33	15	Auxiliary Switch Power 2
F34	20	Seat Power
F35	20	Auxiliary Switch Power 3
F36	20	Power Connector 1/Switched Power
F37	15	SASA Kick-out Signal
F38	20	Primary Controller Power (beneath cab)
F39	20	Secondary Controller Power (beneath cab)
F40	15	HVAC Clutch
<b>Relay</b>	<b>Rating (Amps)</b>	<b>Function</b>
CR01	35	Rotating Beacon Lights
CR02	35	Wiper
CR03	35	Wiper/Washer
CR04	35	Field Lights 1
CR05	20	Field Lights 2
CR06	20	Start Relay
CR07	35	Auxiliary Relay 1
CR08	20	SASA Kick-out Relay
<b>Relays - External Harness (Located beneath right-hand side of cab)</b>		
	<b>Rating (Amps)</b>	<b>Function</b>
	30A/50A	Solution Pump Signal
	30A/50A	Solution Pump Return
	30A/50A	Solution Pump Enable
<b>Fuses and Relays - Final Tier 4 Engine (Located on engine skid beneath batteries)</b>		
<b>Fuse (Mini)</b>	<b>Rating (Amps)</b>	<b>Function</b>
F01	15	DEF Line
F02	10	After Treatment

**SECTION 6 –  
ELECTRICAL SYSTEMS**



F03	15	DEF Module
F04	30	Engine ECM
F05	30	Start
F06	20	Auxiliary Battery Power
<b>Diode</b>	<b>Rating (Amps)</b>	<b>Function</b>
D01	6	Grid Heater
<b>Relay</b>	<b>Rating (Amps)</b>	<b>Function</b>
CR01		DEF Line 1
CR01		DEF Line 2
CR03		DEF Line 3
CR04		After Treatment
CR05		DEF Module
CR06		Starter



## SECTION 7 – SPRAY SYSTEMS

### SPRAY BOOMS

(60/80' and 60/90')

The spray booms are controlled by an electro-hydraulic system. This system consists of operator-manipulated switches (located on the side console and the hydrostatic drive control handle) and hydraulic cylinders (attached to the booms), which provide lift, level, and horizontal extension.

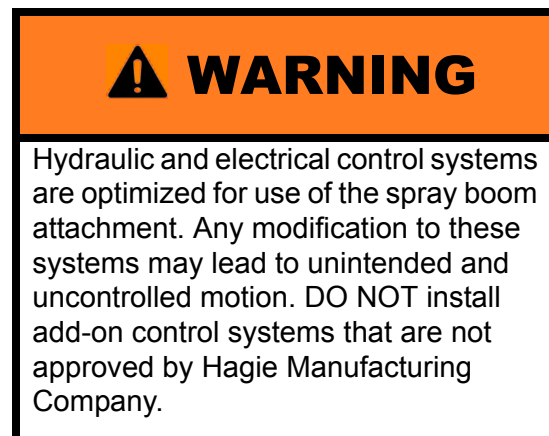
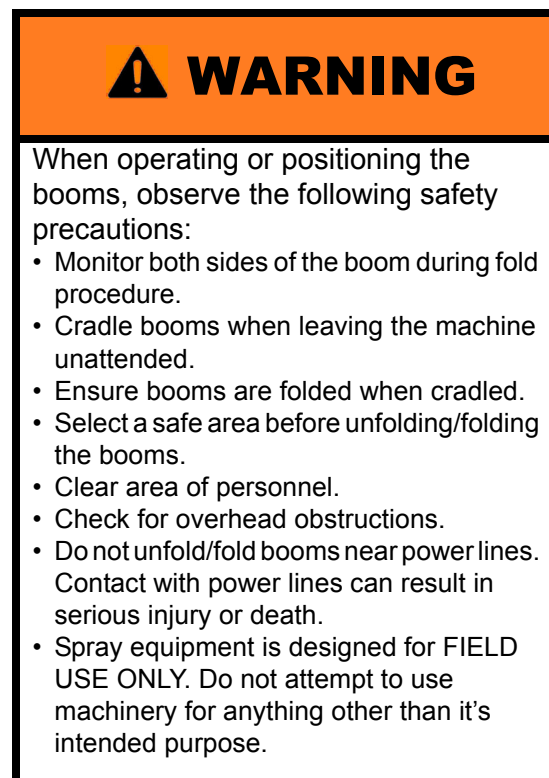

**⚠ CAUTION**

When operating or positioning the booms, observe the following safety precautions. Failure to comply may result in injury or equipment damage.

- Do not unfold/fold boom extensions when main boom is in cradle.
- Do not operate machine with one boom out of cradle and the other boom in cradle.
- Ensure booms are folded and in cradle before transporting the machine.

**Power Lines**

Hagie Manufacturing Company cannot stress enough that extreme caution must be taken when operating equipment near power lines. Ensure there is more than sufficient clearance when transporting, unfolding and folding the boom, or spraying near power lines.



As a safety precaution, a Power Line Warning Message will appear on the Machine Display before extending the outer boom extensions. Press ACKNOWLEDGE showing that you have acknowledged that there are no overhead power lines or obstructions before proceeding.

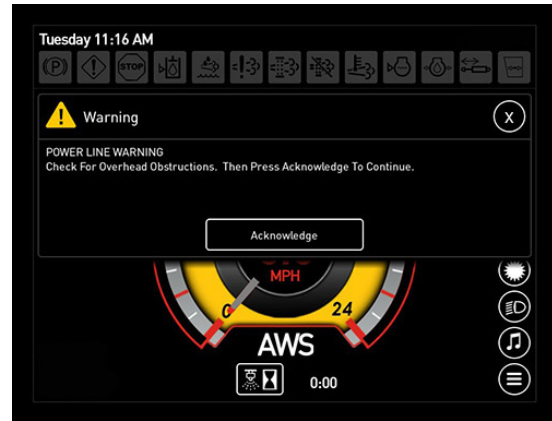

Power Line Warning Message  
(Located on the Machine Display)

Hydraulically folding the extensions of a 60/80-ft. or 60/90-ft. spray boom and shutting off the outer sections essentially turns it into a 60-ft. spray boom.

Refer to the Spray System Console calibration information provided elsewhere in this section for further information.



Boom Extensions - Outer Fold  
(Folded position)  
-Typical View



Boom Extensions - Outer Fold  
(Extended position)  
-Typical View

**Spray Boom Components**

- (A) - Transom
- (B) - Main Boom Section
- (C) - Boom Extension (Outer Fold)
- (D) - Level Cylinders (2)
- (E) - Lift Cylinders (2)
- (F) - Fold Cylinders (2)
- (G) - Main/Outer Fold Block
- (H) - Lift/Level Block
- (I) - Outer Fold Cylinders

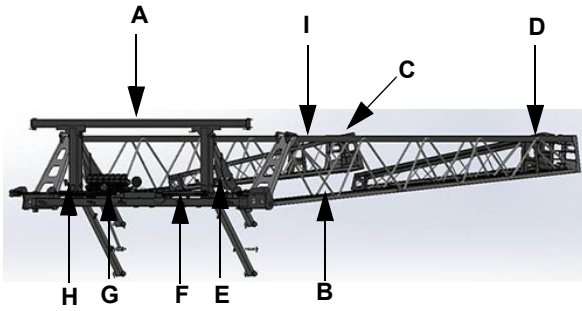

hydraulic circuit (located on the fold manifold) provides main fold boom breakaway in severe conditions.



Main Boom Breakaway  
-Typical View

### Recharging Breakaway Circuits

In the event that the main or outer boom fold section breaks away or the machine is turned off with the boom in the spray position, a warning message will appear stating that the boom is in the spray position, but not charged. Press OK to acknowledge and recharge by pressing the corresponding Left or Right-Hand Boom Switch (located on the Hydrostatic Drive Control Handle) in the OUT position to move the boom back into position and recharge the circuit.

In addition to the boom charge warning message, a boom charge indicator will illuminate along the top of any given display page.

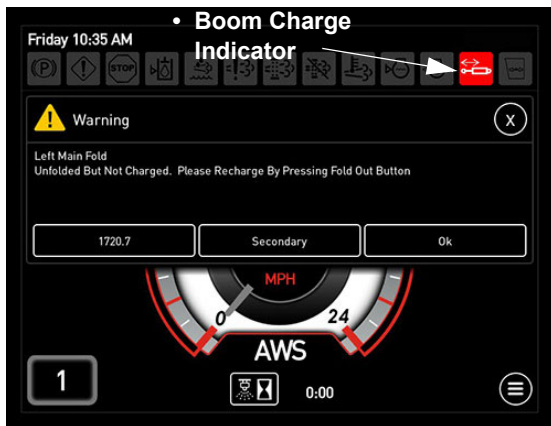

Boom Charge Warning

**NOTE:** Failure to recharge the boom circuits can result in the booms drifting back at the fold joints.

### Main Boom Breakaway

The spray boom is equipped with a hydraulic main fold breakaway circuit. When folded out as an 80 or 90-ft. spray boom, a

### To Reset the Main Boom Breakaway

- Once the boom has broken away and movement has stopped, press the corresponding Left or Right-Hand Boom Switch (located on the Hydrostatic Drive Control Handle) in the OUT position to move the boom back into position and recharge the circuit.

**NOTE:** The boom will begin to react to the breakaway event once pressure has reached the direct acting relief setting of 3500 psi (241 bar).

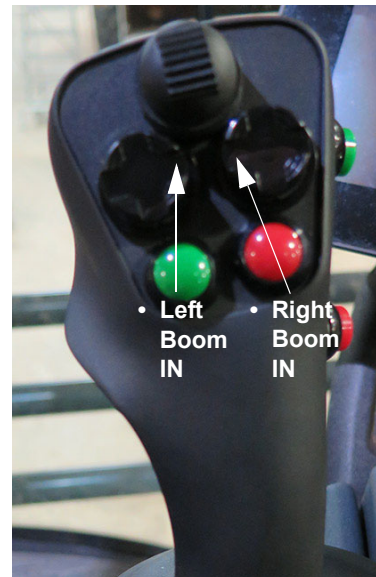

Left and Right-Hand Boom Switches  
(Located on the Hydrostatic Drive Control Handle)  
-Typical View

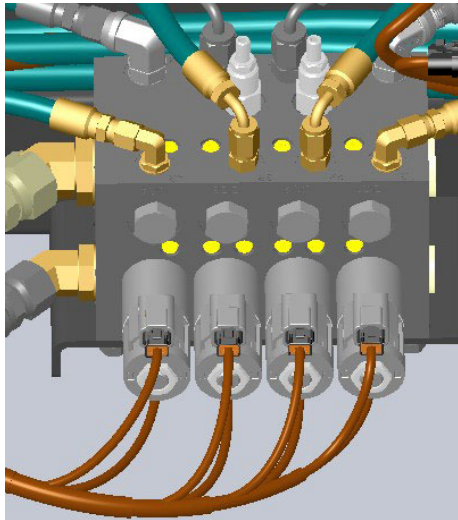

Hydraulic Kick-Down Relief  
- Main Boom Breakaway  
(Located on center of transom)  
-Typical View

- Press and hold the corresponding Left or Right-Hand Boom Switch in the OUT position until the main fold section has resumed spray position.

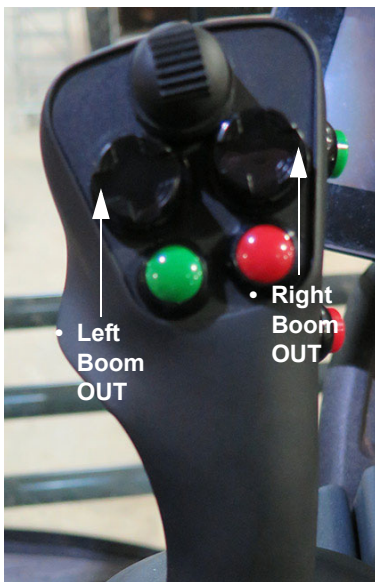

Left and Right-Hand Boom Switches  
(Located on the Hydrostatic  
Drive Control Handle)  
-Typical View

**NOTE:** The main boom breakaways cannot be folded unless machine speed is less than 10 mph (16 km/h).

### Outer Boom Breakaways

The spray boom is equipped with a hydraulic outer breakaway circuit. When folded out as an 80 or 90-ft. spray boom, a one-way hydraulic circuit (located on the outer boom section) provides outer boom breakaway functions.



Outer Boom Breakaway  
-Typical View

### To Reset the Outer Boom Breakaway

- Once the boom has broken away, press the corresponding Boom Extension Switch (located on the side console) momentarily in the DOWN (In) position to stop movement and reset the hydraulic kick-down relief.

**NOTE:** Hydraulic kick-down relief breaks at 4000 psi (275 bar).



Boom Extension Switches - Left/Right  
(Located on the side console)  
-Typical View

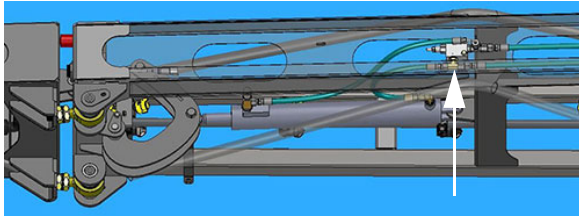

Hydraulic Kick-Down Relief  
- Outer Boom Breakaways  
(Located on each outer boom section)  
-Typical View

- Press and hold the corresponding Boom Extension Switch in the UP (Out) position until outer boom section has resumed spray position.

## Auto Fold

-If Equipped



The Auto Fold feature is the preferred method for folding/unfolding the spray boom and makes operation of the machine easier for the operator.

*NOTE: Ensure the Hydrostatic Drive Control Handle is in the NEUTRAL position. If the machine is put in gear during fold operation, boom movement will stop.*

1. Press the Attachment Button (located on the Machine Display Main Menu Page) to navigate to the “Boom State” screen.

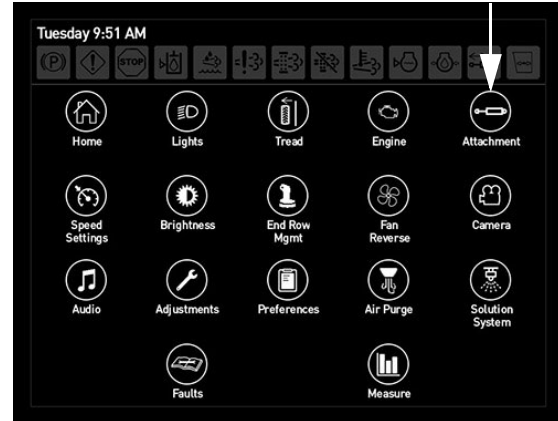

Attachment Button  
(Located on the Machine Display  
Main Menu Page)

2. On the “Boom State” screen, swipe the Manual/Auto Mode slide bar to AUTO.

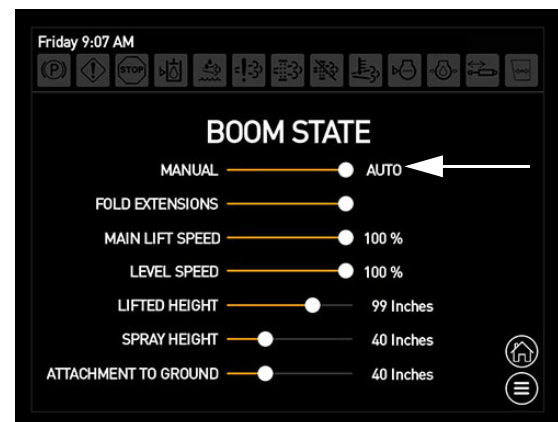

Manual/Auto Mode  
(Located on the Boom State Screen)

3. On the “Boom State” screen, swipe the Fold Extension Mode slide bar to the RIGHT (On) position to enable Auto Fold operation of the outer fold extensions.

*NOTE: Fold Extensions must be activated to enable Auto Fold operation of the outer fold sections.*

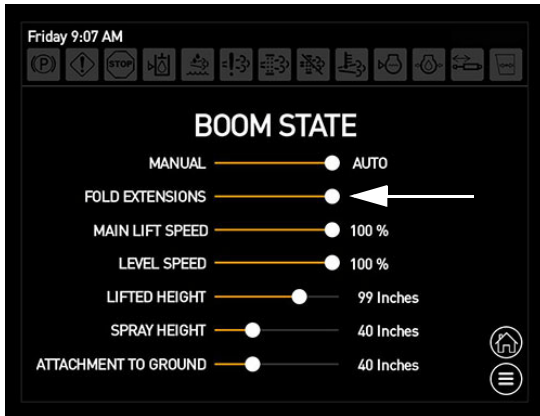

Fold Extension Mode  
Boom State Screen

When “Auto” and “Fold Extensions” are activated, the boom will operate with the Boom Extension Switches (located on the side console).

*NOTE: When the Fold Extensions are disabled, the main boom will fold/unfold, but the outer fold sections will not.*

4. Press and hold **both** Left and Right Boom Extension Switches (located on the side console) UP to unfold the boom to the fully extended position on all sections.



Boom Extension Switches - Left/Right  
(Located on the side console)  
-Typical View

5. Press and hold **both** Left and Right Boom Extension Switches (located on

the side console) DOWN to fold the boom in to the fully retracted position.

### Manual Fold



### **CAUTION**

Booms will unfold even if they are still in the boom cradle or are not horizontally extended.

### **NOTICE**

Do not lower the main lift while the boom is in cradle. Failure to comply will result in property damage.

### Manual Unfold (Extend)

*NOTE: Ensure the Hydrostatic Drive Control Handle is in the NEUTRAL position. If the machine is put in gear during fold operation, boom movement will stop.*

1. Press the Attachment Button (located on the Machine Display Main Menu Page) to navigate to the “Boom State” screen.





Attachment Button  
(Located on the Machine Display  
Main Menu Page)

2. On the “Boom State” screen, swipe the Manual/Auto Mode slide bar to MANUAL.

*NOTE: When Manual Mode is activated,  
Fold Extensions will be disabled.*

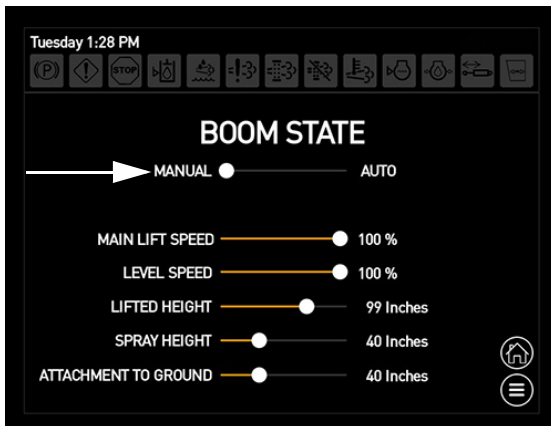

Manual/Auto Mode  
(Located on the Boom State Screen)

3. Press and hold the corresponding Left and Right-Hand Boom Switches (located on the Hydrostatic Drive Control Handle) in the UP position to raise the level cylinders all the way up.

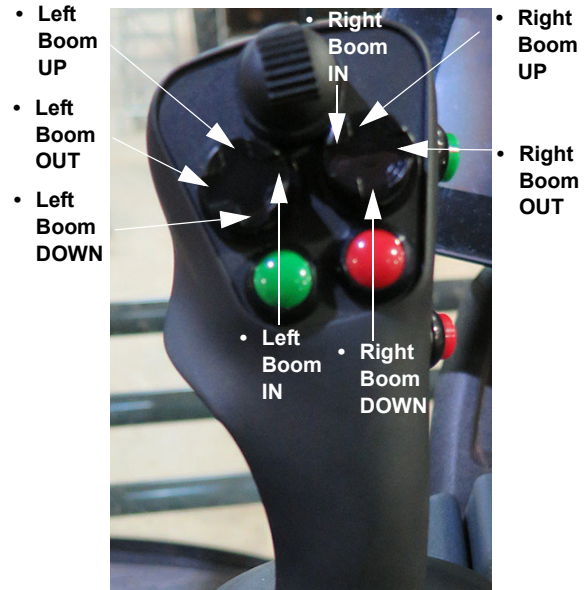

Left and Right-Hand Boom Switches  
(Located on the Hydrostatic  
Drive Control Handle)  
-Typical View

4. Press and hold the corresponding Left and Right-Hand Boom Switches in the OUT position to unfold the main boom sections until they come to a complete stop.
5. Lower the level cylinders until the boom is parallel with the ground.
6. Press and hold the corresponding Left and Right Boom Extension Switches (located on the side console) in the UP position to unfold the boom extensions all the way OUT.

## SECTION 7 – SPRAY SYSTEMS



Boom Extension Switches - Left/Right  
(Located on the side console)  
-Typical View

DOWN position to fold the outer fold sections all the way IN.

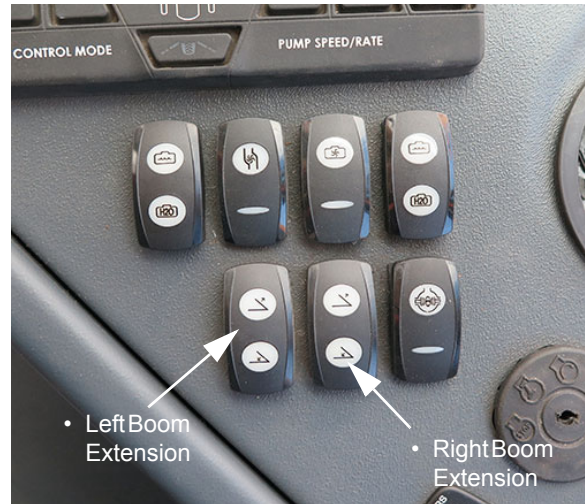

Boom Extension Switches - Left/Right  
(Located on the side console)  
-Typical View

### Manual Fold (Retract)

*NOTE: Ensure the Hydrostatic Drive Control Handle is in the NEUTRAL position. If the machine is put in gear during fold operation, boom movement will stop.*

1. On the “Boom State” screen, ensure the boom state is in Manual Mode.

*NOTE: When Manual Mode is activated, Fold Extensions will be disabled.*

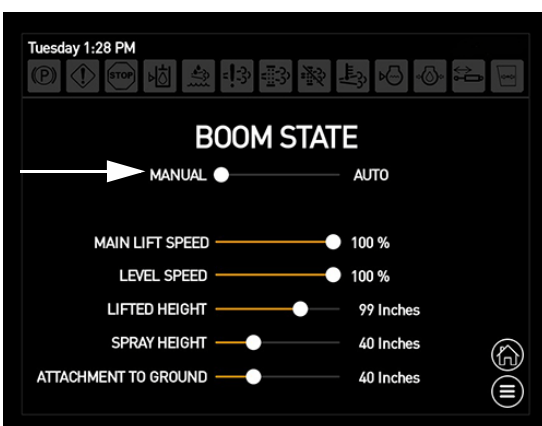

Boom State Screen - Manual Mode

3. Press and hold the Transom Switch (located on the Hydrostatic Drive Control Handle) in the UP position to raise the main lift all the way up.



Transom Switch - UP  
(Located on the Hydrostatic Drive Control Handle)  
-Typical View

2. Lower the level cylinders until the boom is parallel with the ground.
  - Press and hold the corresponding Left and Right Boom Extension Switches (located on the side console) in the

4. Press and hold the corresponding Left and Right-Hand Boom Switches (located on the Hydrostatic Drive Control Handle)

in the IN position until the main boom wings are aligned with boom cradles.

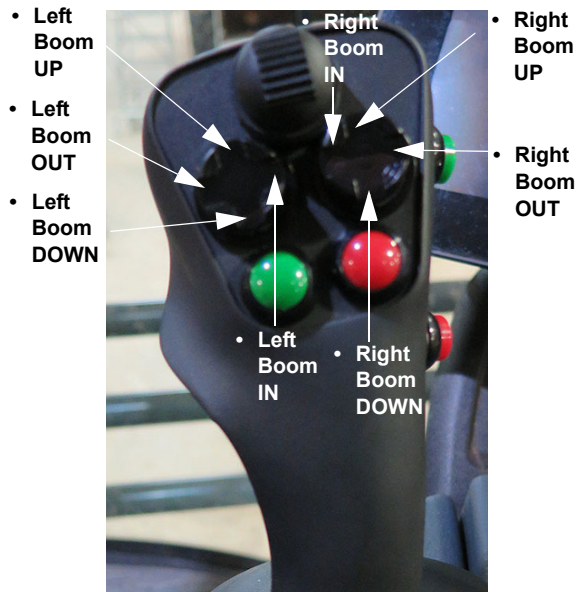

Left and Right-Hand Boom Switches  
(Located on the Hydrostatic  
Drive Control Handle)  
-Typical View

- Lower the level cylinders until the boom sections are seated in the boom cradles.

### Main Lift Speed

Main Lift Speed is the speed in which the transom travels up and down.

- On the “Boom State” screen, use the slide bar (next to Main Lift Speed) to adjust to desired speed.

*NOTE: The higher the percentage, the faster the main lift will move. The lower the percentage, the slower the main lift will move.*

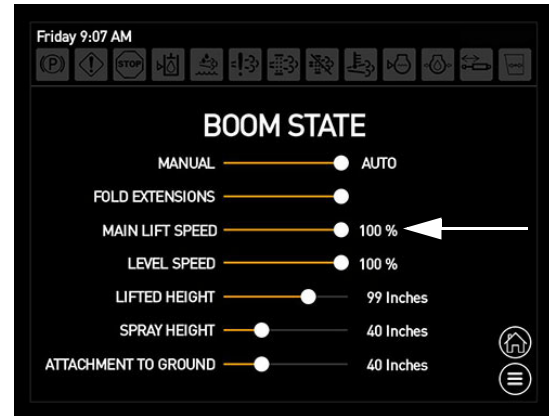

Main Lift Speed  
(Located on the Boom State Screen)

### Level Speed

Level Speed is the speed in which the boom wings travel up and down.

- On the “Boom State” screen, use the slide bar (next to Level Speed) to adjust to desired speed.

*NOTE: The higher the percentage, the faster the boom wings will move. The lower the percentage, the slower the boom wings will move.*

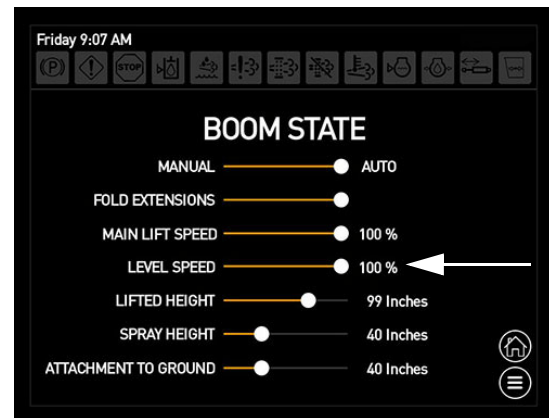

Level Speed  
(Located on the Boom State Screen)

### Return to Height

**(Lifted Height, Spray Height, and Attachment to Ground)**

The Return to Height feature allows the operator to raise the boom to a specified height when the End Row Management

## SECTION 7 – SPRAY SYSTEMS



Switch (located on the Hydrostatic Drive Control Handle) is depressed. The switch will toggle between the “spray” and “lifted” positions each time that it is pressed.

A Return to Height indicator arrow (located on the Machine Display Home Page - Field Mode) will illuminate DOWN when in the “spray” position, and UP when in the “raised” position.

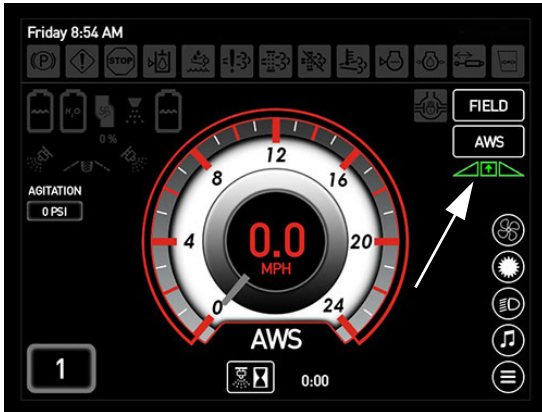

Return to Height Indicator - **UP**  
(Located on the Machine Display Home Page - Field Mode)

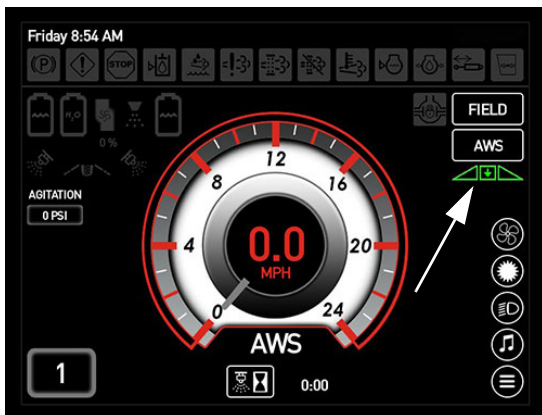

Return to Height Indicator - **DOWN**  
(Located on the Machine Display Home Page - Field Mode)

**NOTE:** If the Transom Switch (located on the Hydrostatic Drive Control Handle) is depressed (or Auto Fold is enabled), the boom will resume to the “spray” position the next time that the End Row Management Switch is pressed.

Refer to the “End Row Management” information elsewhere in this section for programming Return to Height through the End Row Management Switch.

### Return to Height Settings

#### Lifted Height

Lifted Height is the raised boom height position measured from nozzle to ground.

- On the “Boom State” screen, use the slide bar (next to Lifted Height) to adjust to desired value.

**NOTE:** Swipe slide bar to the right to increase value, or to the left to decrease value.

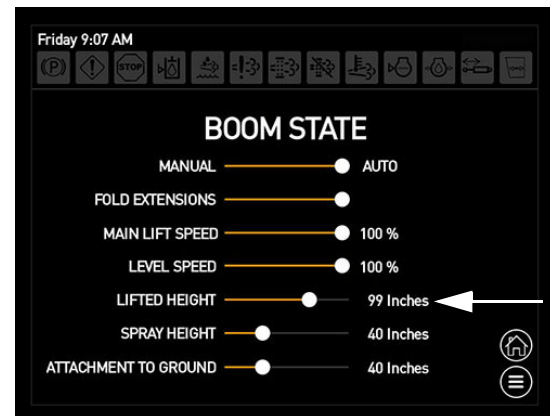

Lifted Height  
(Located on the Boom State Screen)

#### Spray Height

Spray Height is the height that the operator would like the boom to be when spraying (nozzle-to-ground distance).

- On the “Boom State” screen, use the slide bar (next to Spray Height) to adjust to desired value.

**NOTE:** Swipe slide bar to the right to increase value, or to the left to decrease value.

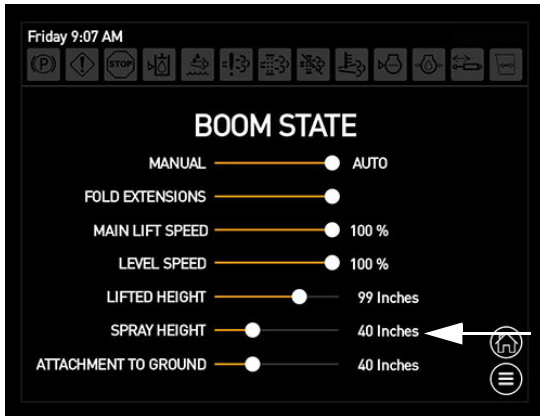

Spray Height  
(Located on the Boom State Screen)

### Attachment to Ground

Attachment to Ground is the height from the spray nozzle-to-ground with the boom in its lowest position.

*NOTE: Attachment to Ground is measured by the operator to better dial in the system if the tires are changed on the machine.*

- On the “Boom State” screen, use the slide bar (next to Attachment to Ground) to adjust to desired value.

*NOTE: Swipe slide bar to the right to increase value, or to the left to decrease value.*

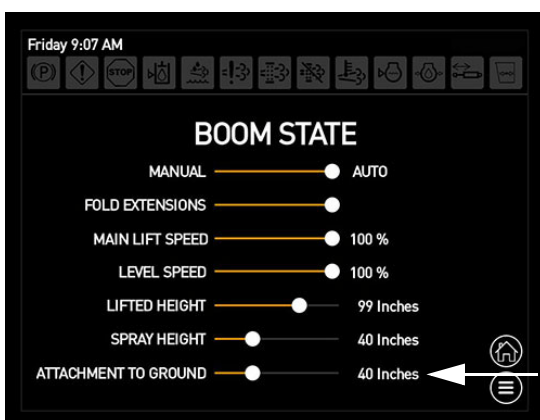

Attachment to Ground  
(Located on the Boom State Screen)

### Further Information

Refer to “Machine Display” provided in the *Cab Section* elsewhere in this manual for information on enabling Return to Height through the End Row Management Switch.

### Enabling/Disabling NORAC® in the Pulse Display

#### -If Equipped

*NOTE: Hagie Manufacturing Company recommends turning the NORAC Monitor OFF when traveling from one field to the next. A power switch is located on the back side of the monitor.*



NORAC Monitor  
-Typical View

- To Enable**, press the desired Auto or Manual Button (located on the main “Run Screen”) to the ON (green illuminated position).

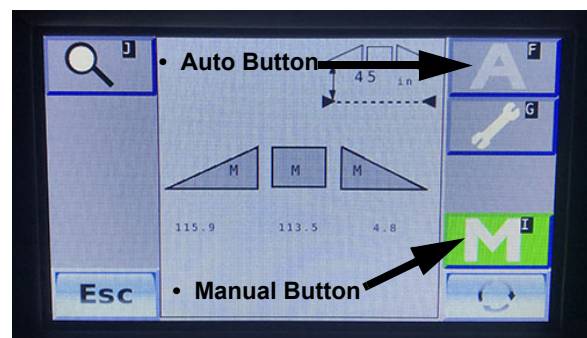

Auto/Manual Buttons  
(Located on the NORAC main “Run Screen”)  
-Typical View

- To Disable**, press the corresponding Auto or Manual Button to the OFF (gray)

position, or press any one of the following boom control switches (located on the Hydrostatic Drive Control Handle):

- **Transom Switch (Up/Down)**
- **Left or Right-Hand Boom Switch (Up/Down)**

*NOTE: In the event that the NORAC System were to become inoperable, the Auto and Manual Fold functions will still operate.*

**Further Information**

Refer to the NORAC manufacturer’s operation manual for complete operating/calibration instructions, troubleshooting information, and safety precautions.

**NORAC System Settings**

**-If Equipped  
(Sensitivity, Soil/Crop Mode, and Target Height)**

**Sensitivity**

Sensitivity is how responsive the system is. The lower the number, the lower the sensitivity. The higher the number, the higher the response time and hydraulic demand.

*NOTE: Default sensitivity setting is 5.*

**On the NORAC Monitor:**

- Press the Settings Button (wrench icon) (located on the main “Run Screen”) to navigate to the Settings Screen.



Settings Button  
(Located on the main “Run Screen”)  
-Typical View

- Press the cell (next to “Sensitivity”) and increase or decrease system sensitivity value from 1-10.

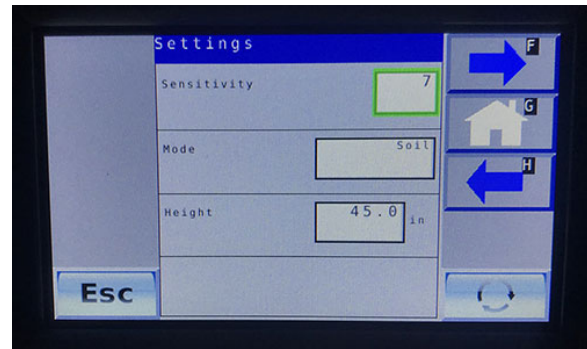

Settings Screen  
-Typical View

**Soil/Crop Mode**

Soil Mode allows the sensors to read the height from the spray nozzles to the ground. Crop Mode allows the sensors to read the height from the spray nozzles to the top of the crop canopy.

**On the NORAC Monitor:**

- Press the Settings Button (wrench icon) (located on the main “Run Screen”) to navigate to the Settings Screen.
- Press the cell (next to “Mode”) and select Soil, Crop, or Hybrid.

*NOTE: Hybrid Mode is an improved Crop Mode, which uses a combination of the crop and soil readings to improve control. This setting is recommended in place of Crop Mode.*

**Target Height**

Target Height is the height you desire the boom to be set at when spraying.

*NOTE: When operating in Soil Mode, the Target Height is measured from the spray nozzles to the soil. In Crop Mode, the target height is measured from the crop canopy to the spray nozzles.*

**On the NORAC Monitor:**

- Press the Settings Button (wrench icon) (located on the main “Run Screen”) to navigate to the Settings Screen.
- Press the cell (next to “Height”) and increase or decrease value to desired boom height.

### Further Information

Refer to the NORAC manufacturer’s operation manual for complete operating/calibration instructions, troubleshooting information, and safety precautions.

Refer to “Specifications” provided in the *Introduction Section* elsewhere in this manual for information on GPS dimensions on your machine.

### Enabling NORAC through the End Row Management Switch

#### -If Equipped

1. Program the End Row Management Switch (located on the Hydrostatic Drive Control Handle) through the Machine Display.

*Refer to “Machine Display” provided in the Cab Section elsewhere in this manual for initial setup instructions.*



End Row Management Switch  
(Located on the Hydrostatic Drive Control Handle)  
-Typical View

2. Press the Settings Button (wrench icon) (located on the main “Run Screen”) to navigate to the Settings Screen.



Settings Button  
(Located on the main “Run Screen”)  
-Typical View

3. On the Settings Screen (1/3), press the “right/forward” blue arrow icon to navigate to the next screen.

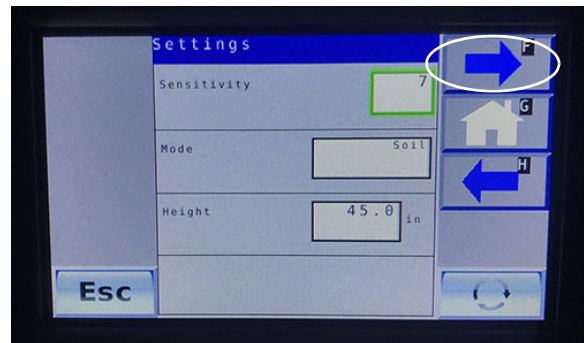

Settings Screen (1/3)  
-Typical View

4. On the Settings Screen (2/3), press the “right/forward” blue arrow icon to navigate to the next screen.
5. On the Settings Screen (3/3), press the “check page” icon.

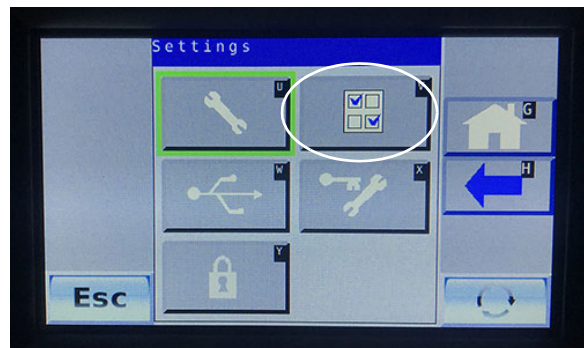

Settings Screen (3/3)  
-Typical View

## SECTION 7 – SPRAY SYSTEMS



- On the Options Screen, ensure the “Remote Switches” option is selected.

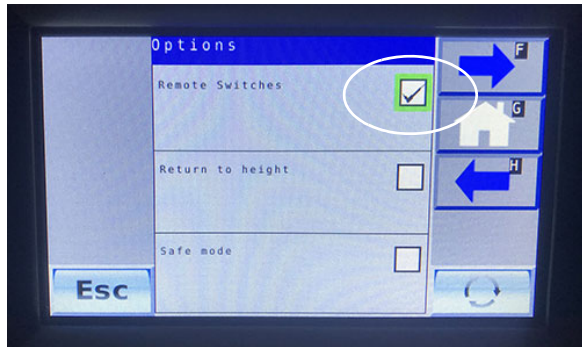

Options Screen  
-Typical View

- Rotate valve towards front of machine to supply solution to the front boom.
- Rotate valve in the upright (vertical) position to shut solution supply OFF.
- Rotate valve towards rear of machine to supply solution to the rear boom.

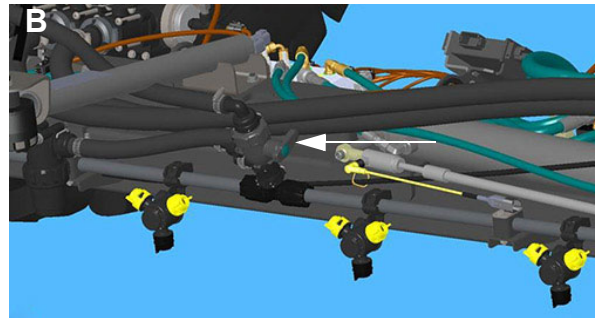

## SPRAY BOOM - REAR

### -If Equipped

*NOTE: The Rear Spray Boom is controlled through the center spray section of the front boom.*

### Installing the Rear Boom

*NOTE: It is recommended that two persons install the Rear Boom.*

- Ensure solution supply is OFF.
- Route solution line from the front boom to the rear boom (A).



- Rotate the 3-Way Boom Valve (B) (located on the center spray section of the front boom) to supply solution to the rear boom.

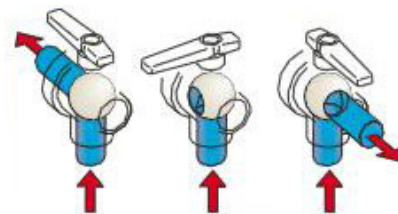

- Insert Rear Boom Tubing (E) into Rear Boom Mounting Bracket (C) (located on outer rear side of machine).

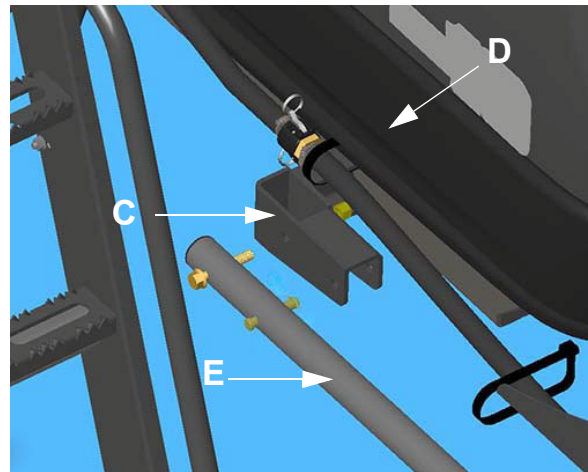

- While maintaining position, install the 1/2” Mounting Bolt (F) through the aligned holes of the boom mounting assembly, into the 1/2” Nyloc Nut (G).
- Install the Securement Pin (H) through the aligned holes of the boom mounting assembly.



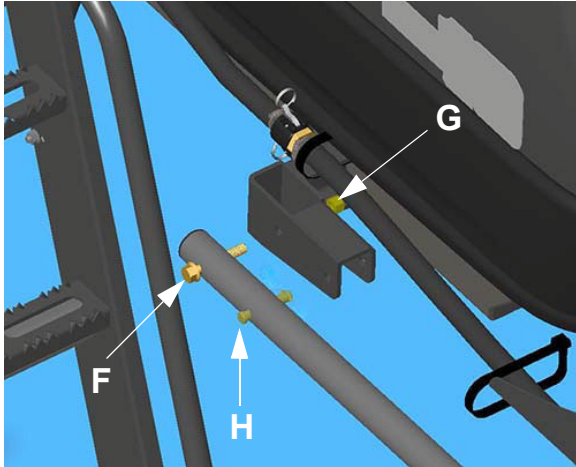

7. Ensuring the boom mounting hardware is aligned, hand-tighten the 1/2" Mounting Bolt (F) until snug.
8. Install Hairpin (I) through the end of the previously installed Securement Pin (H).

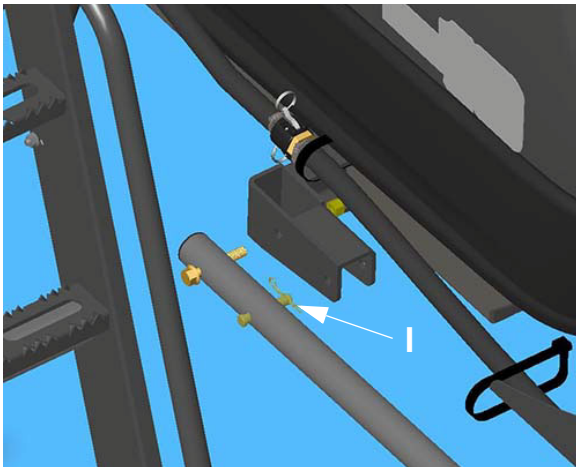

9. Using a 3/4" wrench, tighten the 1/2" Mounting Bolt (F) to 68 ft.-lbs.
10. Repeat Steps 4 through 9 on opposite side of machine.
11. Connect the solution line with the Quick-Connect Fitting (J) (located along side the rear left-hand side of machine).

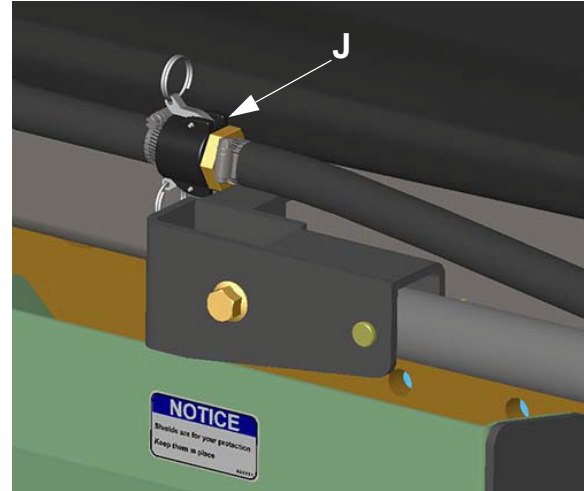

12. Align holes of the horizontal Rear Boom Spray Section (K) with the holes of the Rear Boom Tubing (E).

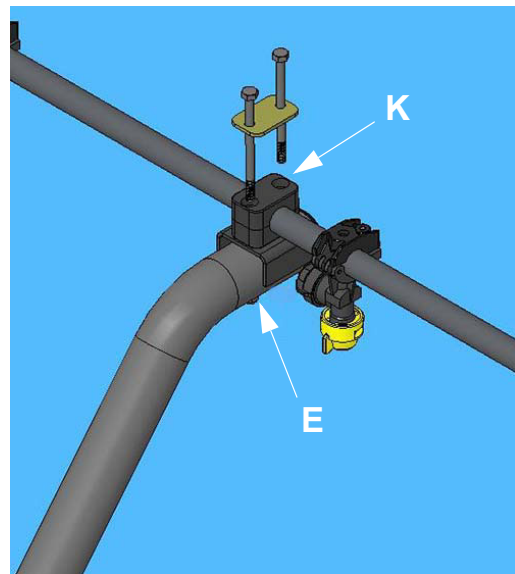

13. Insert the two (2) Spray Section Mounting Bolts (L) through the Mounting Plate (M) and install through the aligned holes of the Rear Boom Spray Section and Tubing Assembly on each side.
14. Install Washer (N) and 1/2" Nut (O) to the bottom of the Spray Section Mounting Bolts (L) as shown and hand-tighten nut on each side.

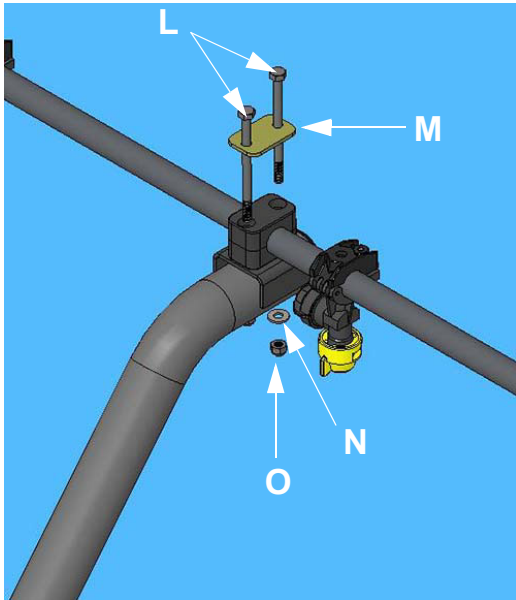

15. Using a 7/16" wrench, tighten the two (2) Spray Section Mounting Bolts (L) to 6 ft.-lbs. on each side.
16. The Rear Spray Boom is now ready for use.



Rear Spray Boom Installation  
-Typical View

## Removing the Rear Boom

Reverse steps to remove the Rear Boom, ensuring that the solution supply and 3-Way Boom Valve are in the OFF position before proceeding.

## SOLUTION SYSTEM COMPONENTS

The Solution System is a constantly monitored, continuously adjusted computer-controlled system. The cab-mounted digital spray system console receives information from various inputs to help determine gallons per acre (GPA)/liters per hectare (l/ha) and gallons per minute (GPM)/liters per minute (l/min).

Please read and understand the information provided in this manual, as well as the spray system console manufacturer's operation manual before operating the solution system. The following information refers to components of the solution system and is not intended to replace the manufacturer's operating instructions.

- Solution Tanks (2)
- Solution Pump
- Solution Pump Switch
- Flow Meter
- Pressure Gauge
- Solution Tank Drain Valves (2)
- Solution Tank Valves (2)
- Tank Valve Selector Switches (Left/Right)
- Agitation Valve
- Agitation Valve Switch
- Jet Agitators (2)
- Boom Solution Valve Switches
- Rate Control Switches
- Pump Speed/Rate Switches
- Master Spray Switch
- Spray System Console
- Air Purge (if equipped)
- Wet Booms
- Nozzle Bodies
- Section Strainers
- Solution Line Strainer

**Solution Tanks (2)  
(500 Gallons/1892 L, each)**

Solution Tank  
-Typical View

**Solution Pump  
(Hypro® 9303C-HM1C w/Silicon Carbide  
Seals)**

The Solution Pump (located beneath center of machine) is a centrifugal-type hydraulically driven pump that is controlled by the solution pump control valve and the spray system console.

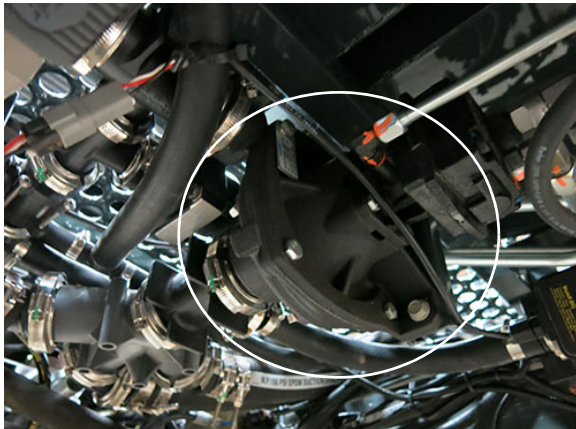

Solution Pump  
(Located beneath center of machine)  
-Typical View

The Solution Pump draws solution out of the tanks at the rate determined during calibration. It dispenses solution through the many valves and hoses that make up the spray system. The Solution Pump also dispenses fluids through the Agitation and Rinse Systems.

Refer to the Spray System Console manufacturer's operation manual for further information on solution pump control.

**Solution Pump Switch**

The Solution Pump Switch (located on the side console) is used to turn on/off the Solution Pump.

*NOTE: Leaving the Solution Pump Switch in the ON position without flow may result in system damage.*

- Press the Solution Pump Switch in the UP position to turn ON (enable).
- Press the Solution Pump Switch in the DOWN position to turn OFF (disable).



Solution Pump Switch  
(Located on the side console)  
-Typical View

*NOTE: When the Solution Pump is ON, a Solution Pump Indicator (located on the Machine Display Home Page - Field Mode) will illuminate.*

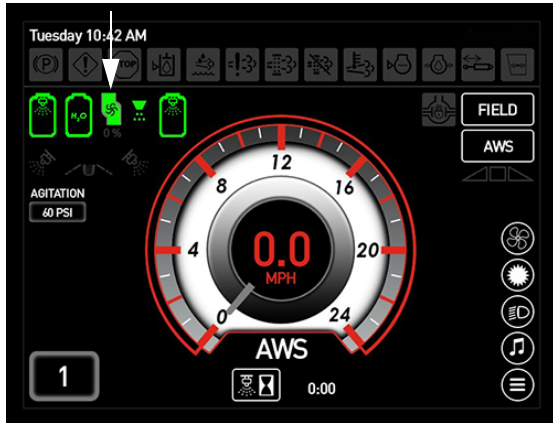

**Solution Pump Indicator**  
(Located on the Machine Display  
Home Page - Field Mode)

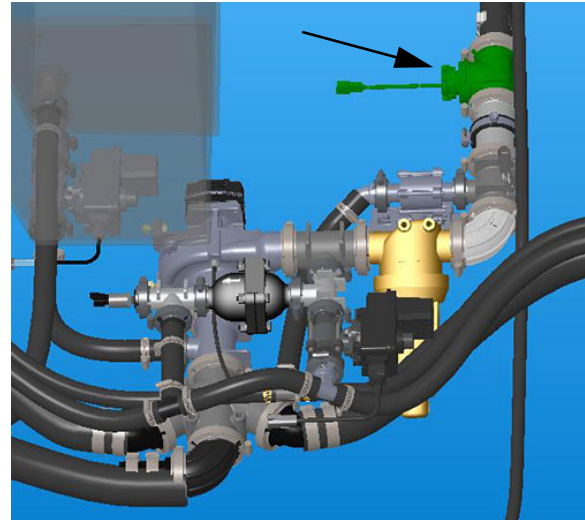

**Flow Meter**  
(Located beneath machine  
inside right-hand frame rail)  
-Typical View

### **Flow Meter**

**(TeeJet® 802)**

The Flow Meter (located beneath machine inside right-hand frame rail) is a turbine-type with sapphire bearing and monitors the solution flow and sends information back to the spray system console. It is featured with a usable range of 3-130 GPM (11.4-492.7 l/min) and diagnostic LEDs for ease of troubleshooting.

*NOTE: Flow Meter Calibration = 79 pulses/  
per gallon (standard volume system).  
Refer to the tag provided on your  
Flow Meter for specific calibration.*

### **Pressure Gauge**

The glycerin-filled Pressure Gauge (mounted on the boom) gives a constant visual display of solution pressure being applied (measured in PSI).

*NOTE: Pressure will vary according to  
speed, application, rate, tip size, etc.*

*NOTE: Activating the Air Purge System (if  
equipped) may cause trapped  
pressure.*

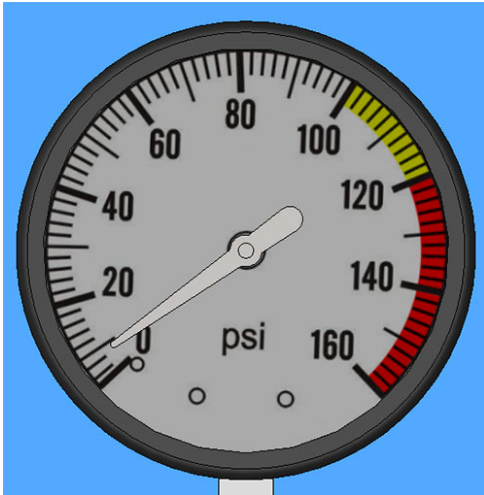

Pressure Gauge  
(Mounted on boom)  
-Typical View

Valve Selector Switches - Left/Right (located on the side console and near the rear fill assembly).

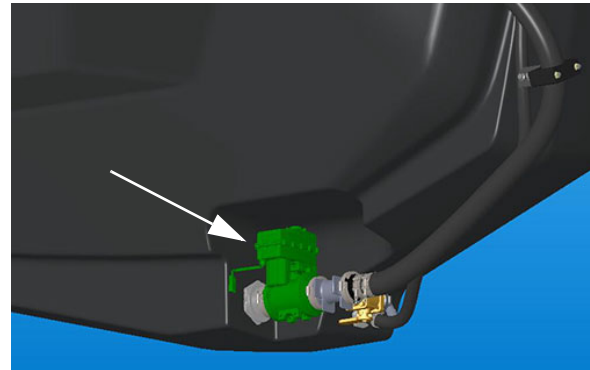

Solution Tank Valve  
(Located beneath each solution tank on underside of machine)  
-Typical View

*\*Right-hand solution tank shown*

### Solution Tank Drain Valves (2)

The Solution Tank Drain Valves (located beneath each solution tank on underside of machine) are used to drain small volumes of residual from the solution tanks.

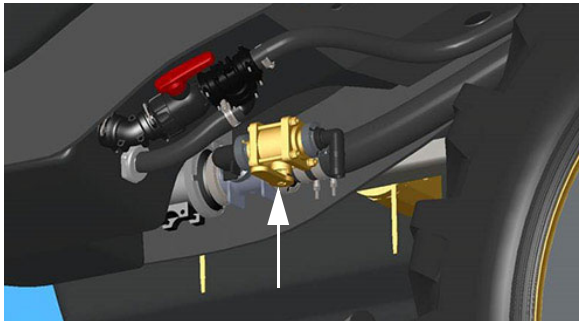

Solution Tank Drain Valve  
(Located beneath each solution tank on underside of machine)  
-Typical View

### Tank Valve Selector Switches (Left/Right)

The three-position Tank Valve Selector Switches (located on the side console) allows the operator to pull from either the solution tank(s) or the rinse tank.

- Press the desired Tank Valve Selector Switch in the UP position to pull product from the corresponding solution tank.
- Press the desired Tank Valve Selector Switch in the DOWN position to pull fresh water from the rinse tank.
- Press the desired Tank Valve Selector Switch in the MID position to turn OFF.

Refer to “Draining Your Solution Tanks” elsewhere in this section for further information.

### Solution Tank Valves (2)

The Solution Tank Valves (located beneath each solution tank on underside of machine) are electric tank shut-off valves. These valves are controlled by the Tank

## SECTION 7 – SPRAY SYSTEMS



Tank Valve Selector Switches - Left/Right  
(Located on the side console)  
-Typical View

**NOTE:** In addition to the Tank Valve Selector Switches inside the cab, the Left/Right Tank Valve Switches (located on the switch box near the ladder) must also be in the ON position to enable spray application.

The Main Tank/Rinse Tank Indicators (located on the Machine Display Home Page - Field Mode) will illuminate to display current status.



Drawing From  
Solution Tanks



Drawing From  
Rinse Tank

Main Tank/Rinse Tank Indicators  
(Located on the Machine Display  
Home Page - Field Mode)

### Agitation Valve

The flow rate of the Agitation System is controlled by an electric Agitation Valve (located near center of machine) to thoroughly mix solution in the tanks and regulate pressure and flow to the Jet Agitators. Increase or decrease agitation flow by operating the Agitation Valve Switch (located on the side console).

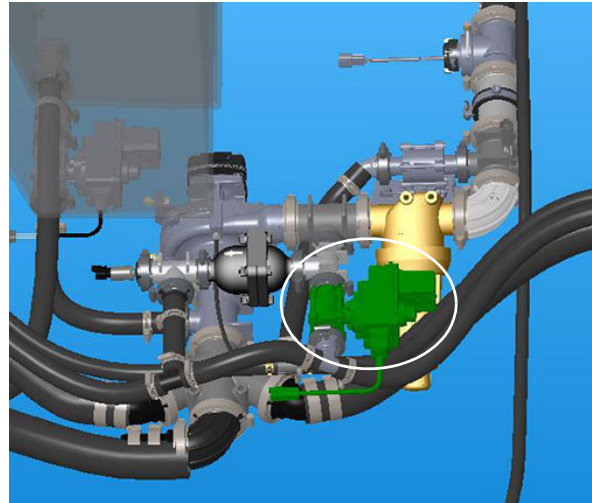

Agitation Valve  
(Located near center of machine)  
-Typical View

\* View shown from top of machine

### Agitation Valve Switch

The Agitation Valve Switch (located on the side console) is used to increase or decrease the agitation valve flow rate.



Agitation Valve Switch  
(Located on the side console)  
-Typical View

- **To increase flow**, press and hold the Agitation Valve Switch in the UP position.
- **To decrease flow**, press and hold the Agitation Valve Switch in the DOWN position.
- Release the Agitation Valve Switch when desired rate of flow is achieved.
- To turn the Agitation System OFF, decrease the flow rate all the way down.

*NOTE: Agitation Valve pressure is displayed on the Machine Display Home Page - Field Mode.*

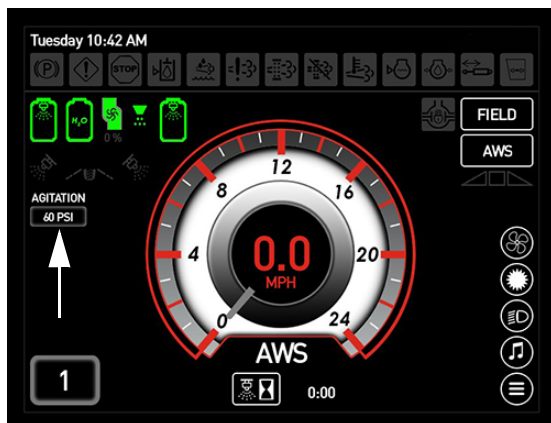

Agitation Valve Pressure Indicator  
(Located on the Machine Display  
Home Page - Field Mode)

### Jet Agitators (2)

The Jet Agitators (located within the sump on each solution tank) are an integral part of the Agitation System. 1/4" nozzles are located on the end of each Jet Agitator (inside of the solution tank) and provide ample agitation and solution suspension.

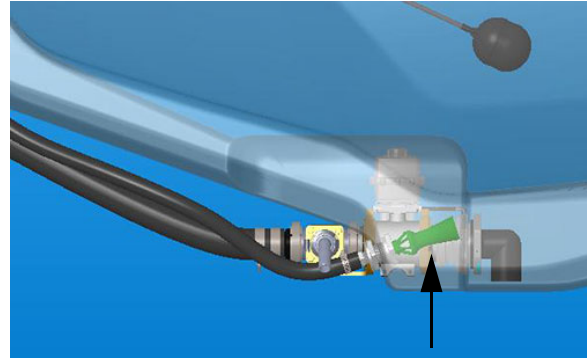

Jet Agitator  
(Located in sump on each solution tank)  
-Typical View

*\*Right-hand solution tank shown*

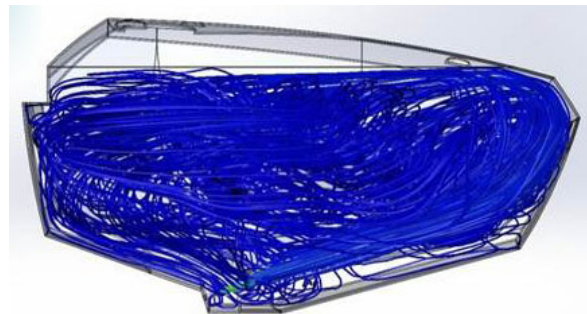

Tank Agitation  
-Typical View

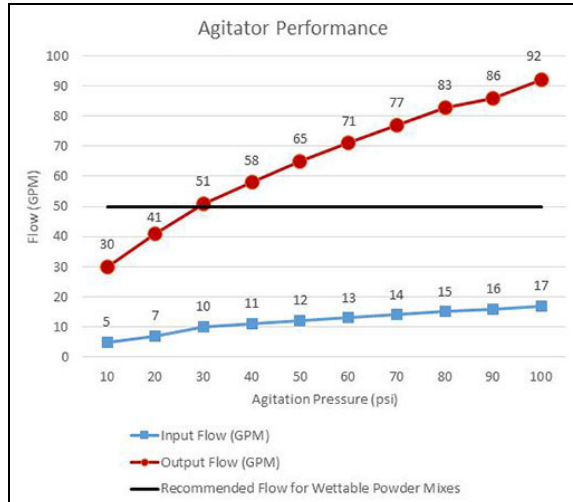

## Boom Solution Valve Switches

The spray booms are divided into sections that are independently supplied with solution and can be turned on or off individually. The electrically-operated Boom Solution Valves are controlled by the Boom Solution Valve Switches (located on the side console).

- Press the Boom Solution Valve Switches to turn ON. Press again to turn OFF.

*NOTE: Each Boom Solution Valve Switch is equipped with an indicator light and will illuminate when the corresponding Boom Solution Valve is OFF.*



Boom Solution Valve Switches  
(Located on the side console)  
-Typical View

## Rate Control Switches

The Rate Control Switches (located on the side console) control the rate in which solution is applied through the spray booms.

- Press ENABLE to allow the rate controller to control the application rate.
- Press MAN (Manual) to control application rate from the section keypad.
- Press ENABLE and MAN to enable manual rate control through the rate controller.



Rate Control Switches  
(Located on the side console)  
-Typical View

*NOTE: When “MAN” is selected, press the Pump Speed/Rate Switches (located on the side console) to increase (+) or decrease (-) application rate. Current solution pump speed is displayed below the Solution Pump Indicator (located on the Machine Display Home Page - Field Mode).*

## Pump Speed/Rate Switches

The Pump Speed/Rate Switches (located on the side console) control the flow rate through the spray system.

*NOTE: These switches are enabled when the “MAN” Rate Control Switch (located on the side console) is previously selected.*

- Press “+” to INCREASE Solution Pump speed.
- Press “-” to DECREASE Solution Pump speed.





Pump Speed/Rate Switches  
(Located on the side console)  
-Typical View

*NOTE: Increasing or decreasing pump speed will change the application rate through the rate controller.*

### Master Spray Switch

Boom Solution Valve Switches are controlled by the Master Spray Switch (located on the Hydrostatic Drive Control Handle) and must be ON to open the electronically-operated Boom Solution Valves.

This allows you to turn all of the Boom Solution Valves on or off at the same time, such as turning them off when you reach the end rows, and turning them back on when you re-enter the field.



Master Spray Switch  
(Located on the Hydrostatic Drive Control Handle)  
-Typical View

*NOTE: When the Master Spray Switch is ON, a Master Spray Indicator (located on the Machine Display Home Page - Field Mode) will illuminate.*

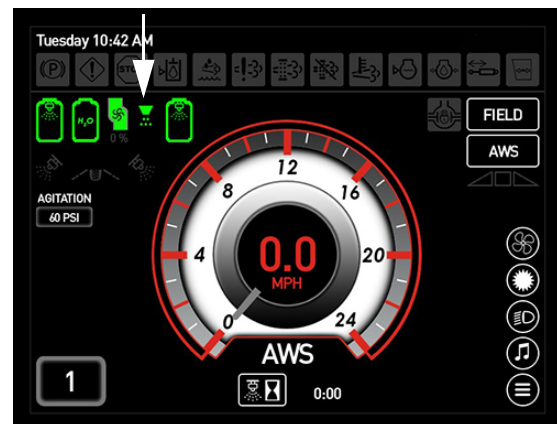

Master Spray Indicator  
(Located on the Machine Display Home Page - Field Mode)

### Precision Display

The spray system is controlled by the Precision Display and the Solution Pump Control Valve. The system receives data and

## SECTION 7 – SPRAY SYSTEMS



automatically makes adjustments based on the target rate of application set by the operator.

Refer to the Precision Display manufacturer's operation manual for complete calibration and operating instructions.



Precision Display  
-Typical View

*(Your machine may vary,  
depending on available equipment)*

### Air Purge

#### -If Equipped

The Air Purge feature on your machine allows you to blow out product from the spray system. You may choose to perform the air purge in either manual or automatic mode.

**NOTE:** Before activating the Air Purge System, ensure no persons are near the spray boom.

In **Manual Mode**, the operator has control of the solution valves by manipulating the Boom Solution Valve Switches (located on the side console section keypad).

In **Automatic Mode**, the air tank on the machine is filled based on engine speed and time to automatically recharge the air tank and purge the spray system. Automatic Air Purge settings include: Full Boom Purge, Individual Section Purge, Air Recharge Time, and Minimum Engine Speed.

Refer to "Machine Display" provided in the *Cab Section* elsewhere in this manual for further information on adjusting Air Purge settings and operating instructions.

### Wet Boom

The 7-section Wet Boom on your machine is featured with 0.5" (1.3 cm) schedule 5 stainless plumbing and delivers solution directly to the spray nozzles, which allows for ease of flushing and cleaning of the boom, as well as decreased contamination/plugging of nozzles.



Wet Boom Plumbing  
-Typical View

Refer to "Spray Booms" elsewhere in this section for further information.

### Nozzle Bodies

Nozzle Bodies are located throughout the boom and consist of a spray tip, gasket, and cap. The spray tip breaks the solution into droplets of correct size and forms a uniform spray pattern.

Some of the Nozzle Bodies on your boom are equipped with "Rapid Stop", which features a stainless riser in the center of the nozzle clamp to significantly reduce the shut-off and turn-on time of the spray tips for more precise application, minimizing product waste.

**NOTE:** The front turret clip on a standard nozzle body is black, whereas the turret clip on a Rapid Stop nozzle is gray.



Visit [www.teejet.com](http://www.teejet.com) for further information.

**Section Strainers**

**(80-Mesh Strainer Screens)**

Section Strainers are located throughout each boom section and filter impurities to aid in the avoidance of spray nozzle buildup.



**Section Strainers**  
(Located throughout each boom section)  
-Typical View

Refer to “Service - Filters” provided in the *Maintenance and Storage Section* elsewhere in this manual for maintenance information.

**Solution Line Strainer**

**(50-Mesh Strainer Screen)**

A Solution Line Strainer is located beneath the center of machine and is the main strainer to filter solution system impurities and maintain consistent application rates.

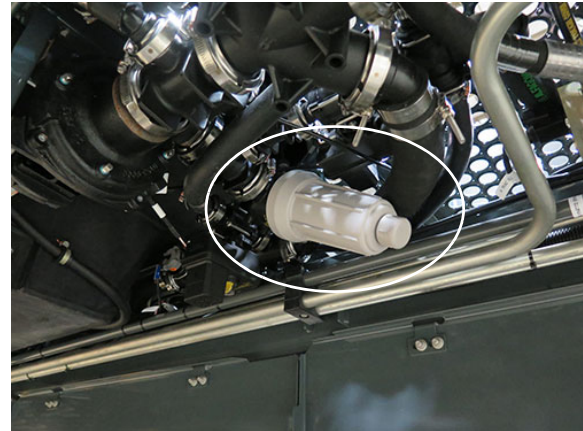

**Solution Line Strainer**  
(Located beneath center of machine)  
-Typical View

Refer to “Service - Filters” provided in the *Maintenance and Storage Section* elsewhere in this manual for maintenance information.

**SOLUTION SYSTEM -  
OPERATION**

**NOTICE**

The Solution System has been tested using RV-type antifreeze. Fill solution tanks with fresh water and drain before initial use.

**NOTICE**

Never attempt to operate the spray system without solution in the tanks. Failure to comply will cause severe equipment damage and will void the warranty.

*NOTE: Ensure the Master Spray Switch (located on the Hydrostatic Drive Control Handle) is in the OFF position before activating the*

## SECTION 7 – SPRAY SYSTEMS



*Solution Pump Switch or the Boom Solution Valve Switches, unless you are ready to begin spray application.*

### Getting Started

1. Calibrate the Spray System Console (refer to the manufacturer's operation manual for calibration instructions).
2. Ensure there is adequate amount of solution in the tanks.
3. Press the Left/Right Tank Valve Switch(es) (located on the switch box near the ladder) in the UP (On) position.

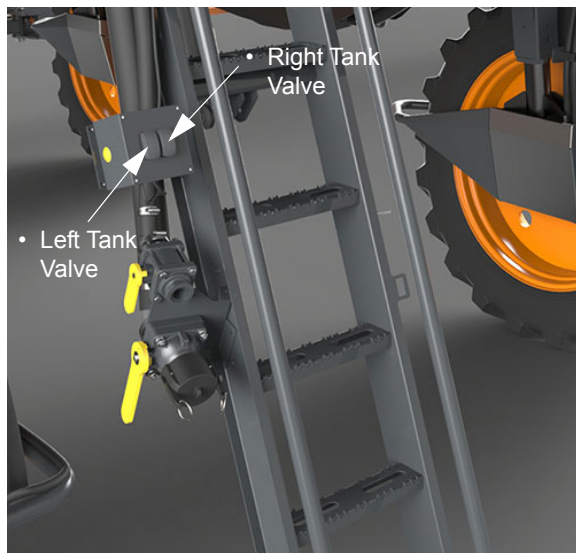

Left/Right Tank Valve Switches  
(Located on switch box near the ladder)  
-Typical View

4. Ensure the Hydrostatic Drive Control Handle is in the NEUTRAL position and parking brake is engaged.
5. Start the engine.
6. Press the Field/Road Button (located on the Machine Display Home Page) and change the machine's drive state to FIELD.

**NOTE:** *The drive state of the machine cannot be changed unless the Hydrostatic Drive Control Handle is in the NEUTRAL position (and machine speed is less than 0.5 mph/ 0.8 km/h).*



Field/Road Button  
(Located on the  
Machine Display Home Page)

7. Position boom to desired position.
8. Press the Tank Valve Selector Switch(es) - Left/Right (located on the side console) in the UP (Main Tank) position.  
If desired, activate the Agitation Valve Switch (located on the side console). Press and hold switch UP to increase flow, or DOWN to decrease flow.

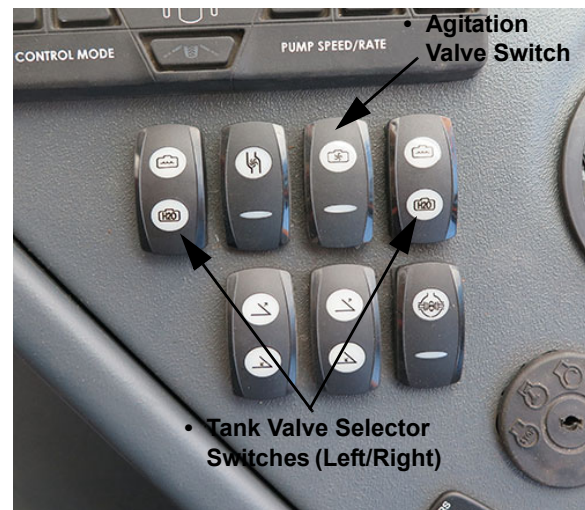

Tank Valve Selector/Agitation Valve Switches  
(Located on the side console)  
-Typical View

**NOTE:** *Main Tank status and Agitation Valve pressure are displayed on the Machine Display Home Page (Field Mode).*

- Main Tank Indicators

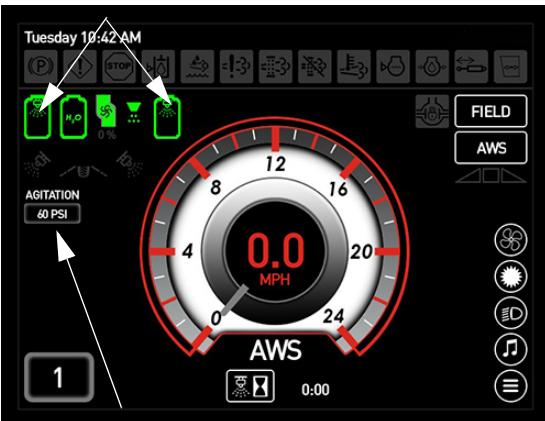

- Agitation Valve Pressure Indicator

Main Tank/Agitation Valve Pressure Indicators  
(Located on the Machine Display Home Page - Field Mode)

9. Press desired Rate Control Switch (located on the side console).
- Press ENABLE to allow the rate controller to control application rate.
  - Press MAN (Manual) to control application rate from the section keypad.
  - Press ENABLE and MAN to enable manual rate control through the rate controller.

*NOTE: When "MAN" is selected, press the Pump Speed/Rate Switches (located on the side console) to increase (+) or decrease (-) application rate. Current solution pump speed is displayed below the Solution Pump Indicator (located on the Machine Display Home Page - Field Mode).*

*NOTE: Increasing or decreasing pump speed will change the application rate through the rate controller.*



Rate Control and Pump Speed/Rate Switches  
(Located on the side console)  
-Typical View

10. Press the Solution Pump Switch (located on the side console) in the UP (On) position.

### NOTICE

Do not allow the Solution Pump to run continuously while the Boom Solution Valve Switches are off. Failure to comply will generate overheating, causing severe pump damage and will void the warranty.

## SECTION 7 – SPRAY SYSTEMS



Solution Pump Switch  
(Located on the side console)  
-Typical View

11. Turn the Master Spray Switch (located on the Hydrostatic Drive Control Handle) ON.



Master Spray Switch  
(Located on the Hydrostatic  
Drive Control Handle)  
-Typical View

*NOTE: When the Master Spray Switch is ON, a Master Spray Indicator (located on the Machine Display Home Page - Field Mode) will illuminate.*

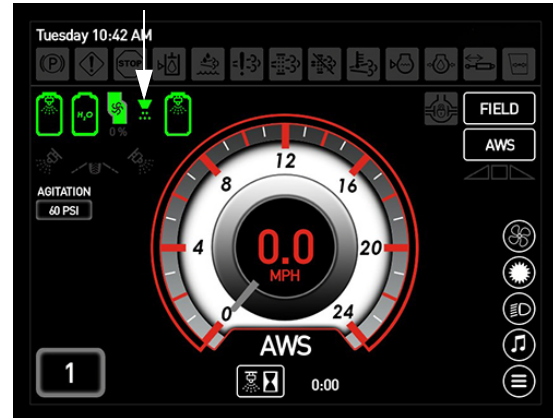

Master Spray Indicator  
(Located on the Machine Display  
Home Page - Field Mode)

12. Press the individual Boom Solution Valve Switches (located on the side console) to the ON (non-illuminated) position.

*NOTE: Each Boom Solution Valve Switch is equipped with an indicator light and will illuminate when the corresponding Boom Solution Valve is OFF.*



Boom Solution Valve Switches  
(Located on the side console)  
-Typical View

13. Slowly move the Hydrostatic Drive Control Handle forward to obtain desired ground speed.
14. Frequently observe the pressure gauge. If the pressure drops to zero or spray pattern deteriorates, turn OFF the Master Spray, Solution Pump, Tank Valve

Selector, and Agitation Valve Switches until solution is refilled.

## FENCE ROW APPLICATOR

### To Operate the Fence Row Nozzles

*NOTE: Boom Solution Valves 1 or 7 must be in the ON position in order to enable the Fence Row Switches.*

- Press the desired Fence Row Switch - Left or Right (located on the side console) to turn ON. Press switch again to turn OFF.

*NOTE: The corresponding Fence Row Switch (located on the side console) and Fence Row Indicator (located on the Machine Display Home Page - Field Mode) will illuminate when active.*



Fence Row Switches - Left/Right  
(Located on the side console)  
-Typical View

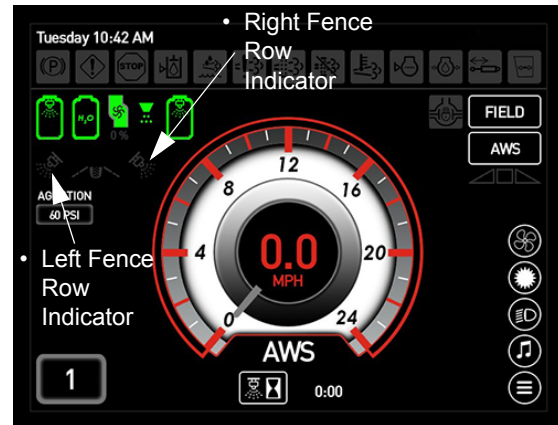

Fence Row Indicators - Left/Right  
(Located on the Machine Display  
Home Page - Field Mode)

### To Operate the Rear Nozzles

*NOTE: The center section of the boom must be in the ON position in order to enable the Rear Nozzles.*

*NOTE: The rear track nozzle is only activated if the Rear Nozzle Switch is depressed and the center section is ON.*

The Rear Nozzle Switch (located on the side console) controls the two (2) rear nozzles (located behind the tires).

- Press the Rear Nozzle Switch to turn ON. Press switch again to turn OFF.

*NOTE: The Rear Nozzle Switch (located on the side console) and Rear Nozzle Indicator (located on the Machine Display Home Page - Field Mode) will illuminate when active.*



Rear Nozzle Switch  
(Located on the side console)  
-Typical View

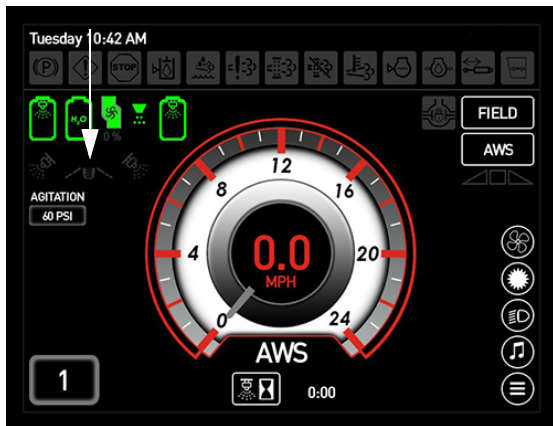

Rear Nozzle Indicator  
(Located on the Machine Display  
Home Page - Field Mode)

## FILLING YOUR SOLUTION TANKS

### **⚠ CAUTION**

Agricultural chemicals can be dangerous. Improper selection or use can injure persons, animals, plants, soils or other property.

#### **TO AVOID INJURY**

1. Select the right chemical for the job.
2. Handle and apply it with care. Follow instructions issued by the chemical manufacturer.

N203265

### **⚠ CAUTION**

Wear the appropriate clothing and Personal Protective Equipment (PPE) when working with agricultural chemicals. Do not store chemical-soaked clothing inside the cab.

### Rear Fill

The fill system utilizes the same hoses and valves as the suction side of the pump. This ensures that the solution pump is primed each time the tanks are filled through the rear fill assembly.

*NOTE: Any air trapped in the solution pump is pushed out through the solution pump vent line. The check valve on the vent line keeps the pump primed even if the tanks are only partially full.*



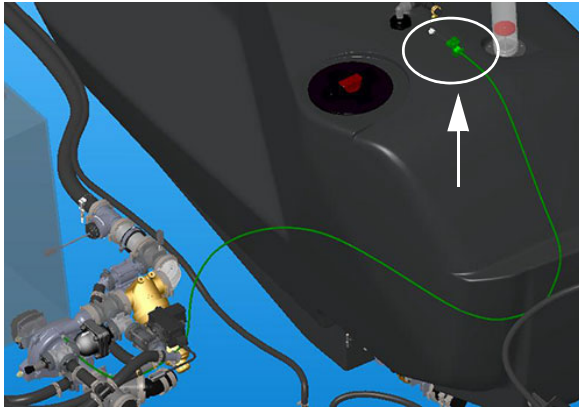

Solution Pump Vent Line/Check Valve  
-Typical View

### Filling the Solution Tanks

*NOTE: Solution Tank Capacity = 500 gallons  
(1892 L)/each*

**NOTICE**

The Tank Valve Selector Switches (Left/Right) inside the cab must be in the UP (Main Tank) position to control filling the solution tanks from the tank fill switch box.

1. Remove fill port cap and connect solution supply to the Solution Tank Fill Port (A).

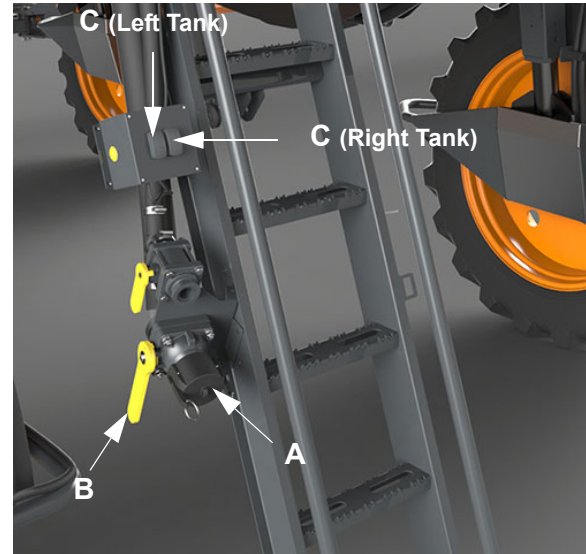

Rear Fill Assembly  
(Located near ladder)  
-Typical View

2. Rotate the Solution Tank Fill Valve (B) in the OPEN (counter-clockwise) position.
3. Press the Left/Right Tank Valve Switch(es) (C) in the UP (On) position and fill tank(s) to desired level.

*NOTE: Solution tanks may be filled separately or simultaneously. In the event that one tank fills faster than the other, press the corresponding Left/Right Tank Valve Switch (C) in the DOWN (Off) position and continue filling the other tank.*

*NOTE: If the agitation system is activated and one tank valve is off for an extended period of time, overflow of the corresponding tank may result.*

*NOTE: A mechanical sight gauge is located at the top of each tank for viewing solution level.*



Solution Tank Sight Gauge (2)  
(Located on top of each solution tank)  
-Typical View

4. **When finished filling the tank(s)**, press both Tank Valve Switch(es) (C) in the UP (On) position.
5. Rotate the Solution Tank Fill Valve (B) in the CLOSE (clockwise) position.
6. Remove solution supply from the Solution Tank Fill Port (A).
7. Reinstall fill port cap.

**Filling the Rinse Tank**

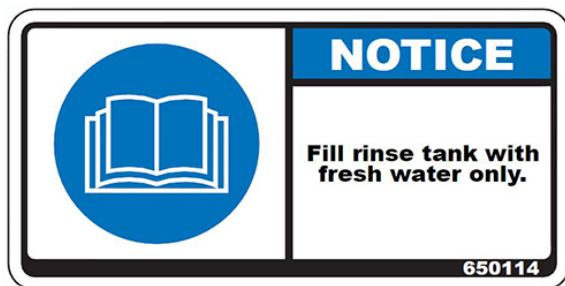

*NOTE: Rinse Tank Capacity = 100 gallons (378.5 L)*

*NOTE: In addition to filling the rinse tank through the rear fill assembly, the tank may also be filled directly through the fill port located on top of the rinse tank.*

1. Remove fill port cap and connect operator-supplied fresh water connection to the Rinse Tank Fill Port (D).

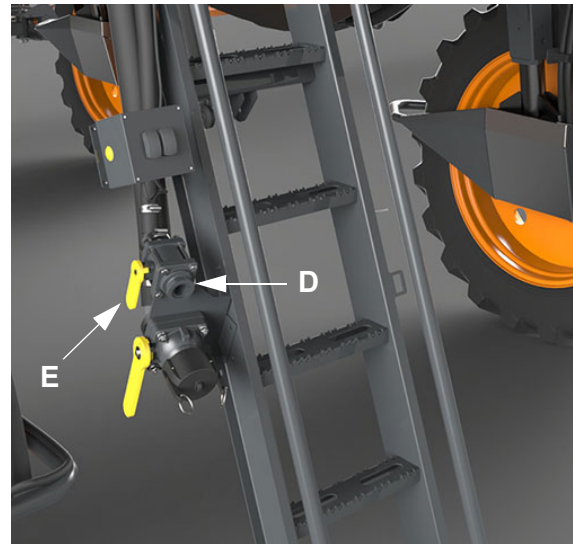

Rear Fill Assembly  
(Located near ladder)  
-Typical View

2. Rotate the Rinse Tank Fill Valve (E) in the OPEN (counter-clockwise) position and fill tank to desired level.

*NOTE: A sight gauge is located on the side of the rinse tank for viewing fresh water level.*



Rinse Tank Sight Gauge  
(Located on the side of rinse tank)  
-Typical View

3. **When finished filling the tank**, rotate the Rinse Tank Fill Valve (E) in the CLOSED (clockwise) position.
4. Remove fresh water supply connection from the Rinse Tank Fill Port (D).
5. Reinstall fill port cap.

**Rinsing the Rear Fill**

1. Remove fill port cap and connect operator-supplied fresh water connection to the Solution Tank Fill Port (A).
2. Turn fresh water supply ON.
3. Rotate the Solution Tank Fill Valve (B) in the OPEN position.
4. **When rinsing is complete**, turn fresh water supply OFF.
5. Close the Solution Tank Fill Valve.
6. Remove fresh water supply connection from the Solution Tank Fill Port and reinstall cap.

**DRAINING YOUR SOLUTION TANKS**

**⚠ CAUTION**

Agricultural chemicals can be dangerous. Improper selection or use can injure persons, animals, plants, soils or other property.

**TO AVOID INJURY**

1. Select the right chemical for the job.
2. Handle and apply it with care. Follow instructions issued by the chemical manufacturer.

N203265

**⚠ CAUTION**

Wear the appropriate clothing and Personal Protective Equipment (PPE) when working with agricultural chemicals. Do not store chemical-soaked clothing inside the cab.

**To Drain the Solution Tanks**

**NOTICE**

When draining large volumes from the solution tanks, it is recommended to pump off with the solution pump by removing the hose that is attached to the section valves.

1. Attach an operator-supplied hose to the end of the desired Solution Tank Discharge Outlet (located beneath each solution tank on underside of machine).

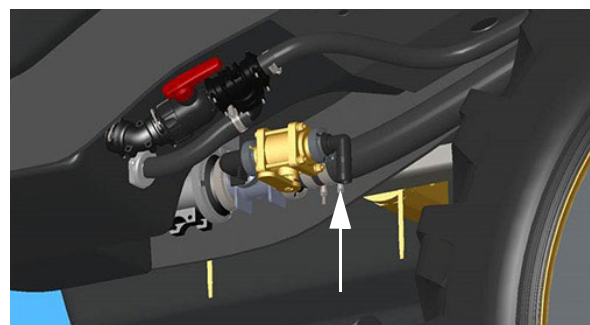

Solution Tank Discharge Outlet  
(Located beneath each solution tank on underside of machine)  
-Typical View

2. Press the corresponding Tank Valve Selector Switch - Left or Right (located on the side console) in the UP (Main Tank) position.

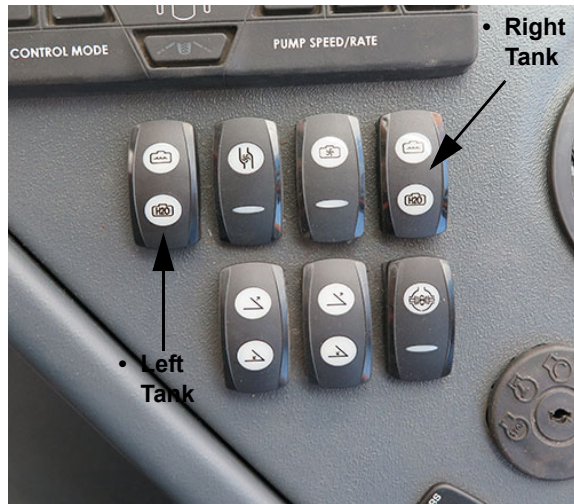

Tank Valve Selector Switches - Left/Right  
(Located on the side console)  
-Typical View

3. Rotate the corresponding Solution Tank Drain Valve (located beneath each solution tank on underside of machine) in the OPEN (counter-clockwise) position and allow solution to drain into an appropriate container for storage.

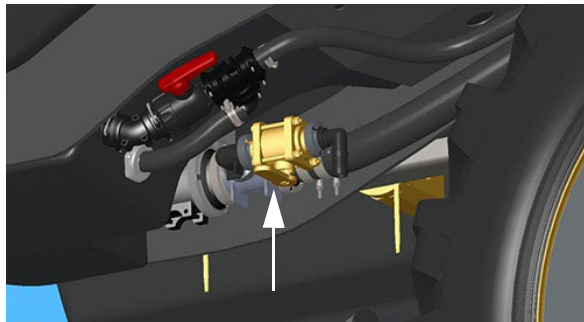

Solution Tank Drain Valve  
(Located beneath each solution  
tank on underside of machine)  
-Typical View

*NOTE: Always ensure that storage containers are clearly marked with what type of chemical is being stored.*

4. **When finished draining the solution tank**, rotate the Solution Tank Drain Valve in the CLOSED (clockwise) position.
5. Press the Tank Valve Selector Switch in the DOWN (Off) position.

6. Remove hose from the Solution Tank Discharge Outlet.
7. Repeat on opposite solution tank if necessary.

## RINSE SYSTEM

Your machine is equipped with a spin ball-type Rinse System (two rotating rinse balls located inside of each solution tank) to easily and effectively rinse the solution tanks, solution pump, and spray booms with fresh water, which protects against cross-contamination of chemicals, as well as reduces the risk of operator exposure. With a 100-gallon (378L) rinse tank (located within the fuel-rinse module behind the cab) full of fresh water, you may rinse the sprayer out immediately after spraying while still in the field. The Rinse System also reduces the extra costs of large volumes of water, as well as additional refilling and sprayer time that are associated with conventional tank rinsing.

The Tank Valve Selector Switches and Tank Rinse Switch (located on the side console) provide functionality of the Rinse System, making it impossible to pull from both the main tanks and the rinse tank accidentally and diluting the product being sprayed. In addition, the operator can add tank cleaner to the main tanks and spray it through the tank rinse nozzles, allowing it to circulate and wash down the tank walls without having to draw water out of the rinse tank.

*NOTE: Ensure the solution tanks are completely empty before activating the Rinse System.*

## NOTICE

Select a safe area to rinse the spray system and clean the sprayer where chemicals will not drift off to contaminate people, animals, vegetation, or water supply.

**NOTICE**

Never attempt to operate the Rinse System without fresh water in the rinse tank. Failure to comply will result in equipment damage and will void the warranty.

**NOTICE**

Fill rinse tank with fresh water only.

650114

Refer to the chemical manufacturer's information for types of cleaning solution combinations (water, cleaning agents, etc.)

### Step 1 - Rinsing the Solution Tanks

1. Press the Tank Valve Selector Switches - Left and Right (located on the side console) in the DOWN (Rinse) position.



Tank Valve Selector Switches - Left/Right  
(Located on the side console)  
-Typical View

2. Press the Tank Rinse Switch (located on the side console) in the UP (On) position to rinse the solution tanks.



Tank Rinse Switch  
(Located on the side console)  
-Typical View

*NOTE: A Rinse Mode Indicator is located on the Machine Display Home Page - Field Mode and will display current rinse mode status.*

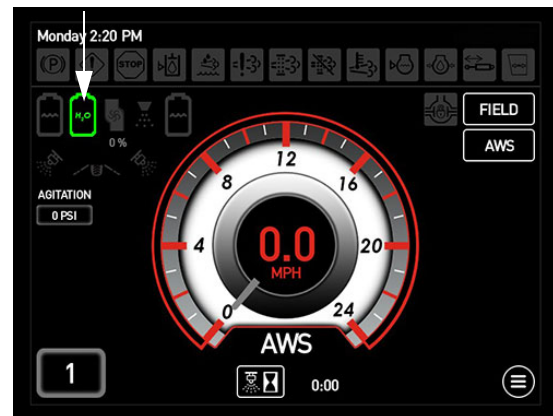

Rinse Mode Indicator  
(Located on the Machine Display Home Page - Field Mode)

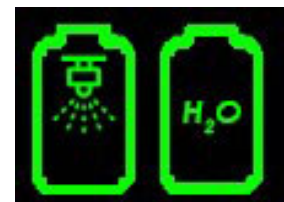

Drawing From Rinse Tank  
and Rinsing Solution Tanks

## SECTION 7 – SPRAY SYSTEMS



3. Press and hold the Agitation Valve Switch (located on the side console) in the UP (Open) position.



Agitation Valve Switch  
(Located on the side console)  
-Typical View

4. Press the Solution Pump Switch (located on the side console) in the UP (On) position.



Solution Pump Switch  
(Located on the side console)  
-Typical View

5. Press the Manual (MAN) Rate Control Switch (located on the side console).

*NOTE: Ensure the Enable Rate Control Switch is in the OFF position.*



Manual “MAN” Rate Control Switch  
(Located on the side console)  
-Typical View

6. Press the “+” Pump Speed/Rate Switch (located on the side console) to increase solution pressure to desired PSI (bar).



“+” Pump Speed/Rate Switch  
(Located on the side console)  
-Typical View

7. When finished rinsing the solution tanks, press the Tank Valve Selector Switches in the MID (Off) position and the Tank Rinse Switch in the DOWN (Off) position.

### Step 2 - Spray Diluted Water from Tanks

1. Press and hold the Agitation Valve Switch (located on the side console) in the DOWN (Closed) position.

2. Press the Tank Valve Selector Switches - Left and Right (located on the side console) in the UP (Main Tank) position.
3. Press the Boom Solution Valve Switches (located on the side console) in the ON position.

*NOTE: Each Boom Solution Valve Switch is equipped with an indicator light and will illuminate when the corresponding Boom Solution Valve is OFF.*



Boom Solution Valve Switches  
(Located on the side console)  
-Typical View

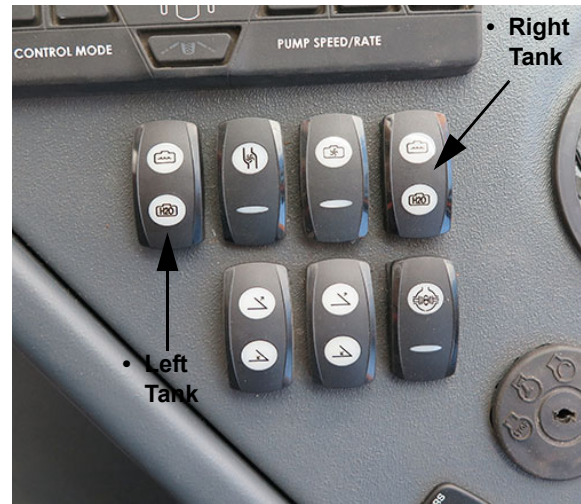

Tank Valve Selector Switches - Left/Right  
(Located on the side console)  
-Typical View

*NOTE: When rinsing the boom and nozzles, ensure the Boom Solution Valve Switches (located on the side console) are in the ON position before activating the Tank Rinse Switch.*

2. Press the Manual (MAN) Rate Control Switch (located on the side console).



Manual "MAN" Rate Control Switch  
(Located on the side console)  
-Typical View

4. Press the Master Spray Switch (located on the Hydrostatic Drive Control Handle) in the ON position.
5. Continue spraying until all diluted water is removed from tanks.

### NOTICE

Do not allow the solution pump to run dry for a prolonged period of time. Failure to comply may result in pump damage.

### Step 3 - Rinsing the Boom and Nozzles

1. Press the Tank Valve Selector Switches - Left and Right (located on the side console) in the DOWN (Rinse) position.

3. Press the "+" Pump Speed/Rate Switch (located on the side console) to increase the solution pressure to desired PSI (bar).



“+” Pump Speed/Rate Switch  
(Located on the side console)  
-Typical View



Master Spray Switch  
(Located on the Hydrostatic  
Drive Control Handle)  
-Typical View

4. Press the Master Spray Switch (located on the Hydrostatic Drive Control Handle) in the OFF position.
5. Press the Solution Pump Switch (located on the side console) in the DOWN (Off) position.
6. When rinsing is complete, press the Tank Valve Selector Switches in the MID (Off) position.

2. Press the Solution Pump Switch (located on the side console) in the DOWN (Off) position.

---

## **SOLUTION PUMP RE-PRIMING**

### **Re-Priming the Solution Pump (Standard Procedure)**

In the event that one solution tank runs empty before the other, or inadvertently sucks in air and the solution pump loses prime, there are two different methods to prime the pump - **1) Refill the solution tanks (if they need to be filled anyway); or 2) Flood the solution pump with the rinse tank (if it is necessary to continue spray application without refilling) as follows:**

1. Press the Master Spray Switch (located on the Hydrostatic Drive Control Handle) in the OFF position.



Solution Pump Switch  
(Located on the side console)  
-Typical View

3. Press and Hold the Agitation Valve Switch (located on the side console) in the DOWN position until the agitation valve is closed.





Agitation Valve Switch  
(Located on the side console)  
-Typical View

4. Press both Tank Valve Selector Switches - Left/Right (located on the side console) in the DOWN (Rinse Tank) position.



Tank Valve Selector Switches - Left/Right  
(Located on the side console)  
-Typical View

5. Wait approximately 10 seconds for the water from the rinse tank to flood the solution pump.
6. Press the Solution Pump Switch in the UP (On) position and check for pressure on the spray boom-mounted pressure gauge.

7. Press both Tank Valve Selector Switches (Left/Right) in the UP (Main Tank) position.

### Re-Priming the Solution Pump (Re-Prime Kit)

#### **Scenario A - one solution tank runs empty when there is product in the other solution tank**

1. Ensure the Solution Pump Switch (located on the side console) is in the DOWN (Off) position.



Solution Pump Switch  
(Located on the side console)  
-Typical View

2. Move the corresponding Tank Valve Selector Switch (located on the side console) for the empty solution tank in the MID (Off) position.

## SECTION 7 – SPRAY SYSTEMS



Tank Valve Selector Switches - Left/Right  
(Located on the side console)  
-Typical View

3. Ensure the Tank Valve Selector Switch for the solution tank with volume remaining is in the UP (Main Tank) position.
4. Press and Hold the Agitation Valve Switch (located on the side console) in the DOWN position until the agitation valve is closed.



Agitation Valve Switch  
(Located on the side console)  
-Typical View

5. Rotate the Re-priming Air Valve (located on top of the right-hand solution tank) in the OPEN position for approximately 30 seconds.

*NOTE: This will allow air to run into solution tank and will later turn into an air and water mixture.*

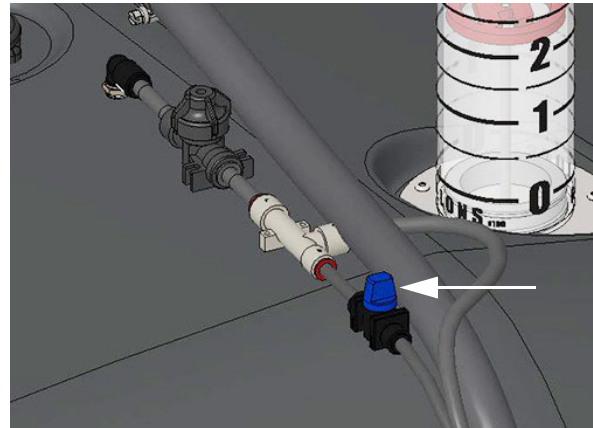

Re-Priming Air Valve  
(Located on top of the  
right-hand solution tank)

6. Rotate the Re-priming Air Valve in the CLOSED position.
7. Press the Solution Pump Switch in the UP (On) position.

*NOTE: Procedure may need to be repeated two (2) times in the event that air is trapped on the suction side of the solution pump.*

**Scenario B - volume in both solution tanks (i.e. solution pump is turned off when liquid level is below agitation nozzles, or vent check valve becomes contaminated resulting in an air leak)**

1. Ensure the Solution Pump Switch (located on the side console) is in the DOWN (Off) position.



Solution Pump Switch  
(Located on the side console)  
-Typical View



Tank Valve Selector Switches - Left/Right  
(Located on the side console)  
-Typical View

2. Press and Hold the Agitation Valve Switch (located on the side console) in the DOWN position until the agitation valve is closed.



Agitation Valve Switch  
(Located on the side console)  
-Typical View

4. Rotate the Re-priming Air Valve (located on top of the right-hand solution tank) in the OPEN position for approximately 30 seconds.

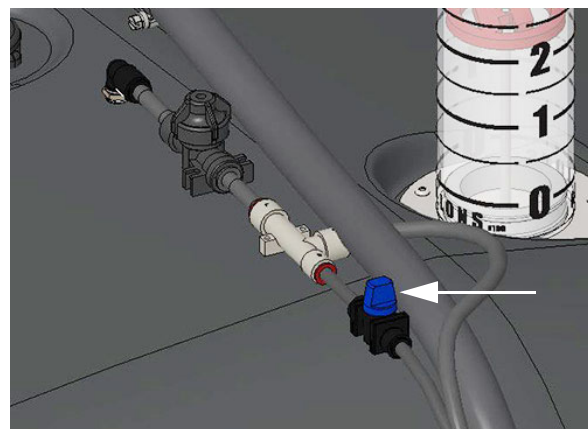

Re-Priming Air Valve  
(Located on top of the  
right-hand solution tank)

3. Ensure both Tank Valve Selector Switches - Left/Right (located on the side console) are in the UP (Main Tank) position.

**NOTE:** This will allow air to run into solution tank and will later turn into an air and water mixture.

5. Rotate the Re-priming Air Valve in the CLOSED position.
6. Press the Solution Pump Switch in the UP (On) position.

**NOTE:** When the solution pump is primed, the agitation valve can be opened in small increments and air bubbles on

## SECTION 7 – SPRAY SYSTEMS



*the suction side can be pumped through the agitation system without the pump losing prime. If prime is lost while trying to cycle through agitation, repeat the procedure.*

### FOAM MARKER SYSTEM

- If Equipped

#### **⚠ CAUTION**

Maximum foam regulator pressure is 20 PSI (1.4 bar). Use of higher pressure may cause personal injury and system damage and will void the warranty.

The Foam Marker system increases efficiency in the field when spraying by utilizing water from the rinse tank and mixing with foam concentrate from the foam reservoir. The system mixes air and concentrate liquid in the nozzle body, eliminating the need for a separate mixing valve on the boom.

### Filling the Foam Marker Reservoir

*NOTE: Foam Marker Reservoir capacity = 1 gallon (3.8 L).*

1. Lift the Foam Marker reservoir fill cap (located on top of the Foam Marker reservoir fill).



Foam Marker Reservoir Fill  
(Located on the front left-hand side of fuel-rinse module - “FRM”)  
-Typical View

2. Fill reservoir to desired level with foam concentrate.
3. Close fill cap when finished.

### Foam Marker Operation

1. Locate the Foam Marker Switch (located on the side console).
  - Press Foam Marker Switch in the UP position if foam application is desired from the Left Foam Drop.
  - Press Foam Marker Switch in the DOWN position if foam application is desired from the Right Foam Drop.
  - Return Foam Marker Switch to the MID (Off) position if no foam is desired.

- Filters” provided in the Maintenance and Storage Section elsewhere in this manual for further information.



Foam Marker Switch  
(Located on the side console)  
-Typical View

2. Observe system pressure indicated on the Air Pressure Gauge (located on the Foam Marker Control Panel in the FRM compartment - lift lid to access).

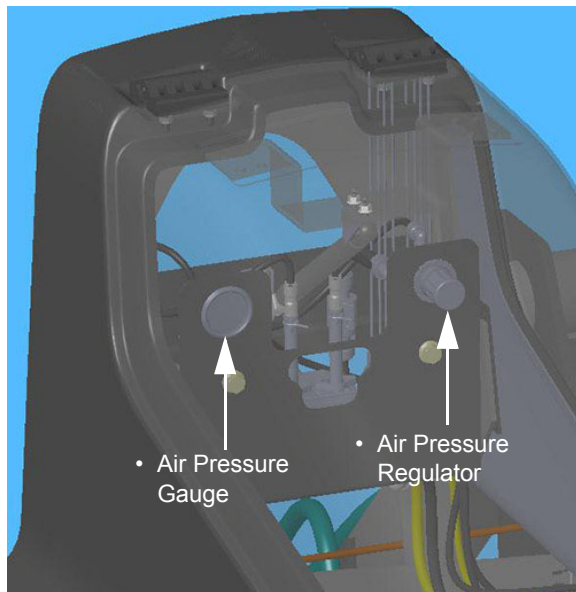

Air Pressure Gauge  
(Located on the  
Foam Marker Control Panel)  
-Typical View

**NOTE:** Remove in-line strainer (located beneath rinse tank on left-hand side of machine) and clean strainer screen if you are unable to obtain adequate pressure. Refer to “Service

### Foam Marker Control Panel

The Foam Marker Control Panel is conveniently located within the fuel-rinse module (FRM) compartment - lift lid to access. The panel includes the air pressure regulator, air pressure gauge, manifold block, concentrate pump, and water pump.

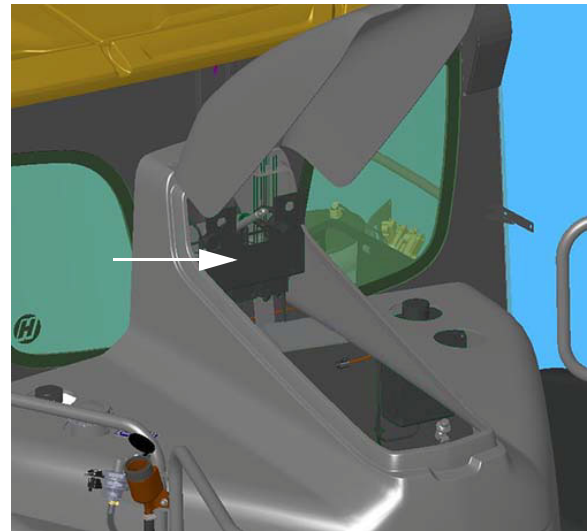

Foam Marker Control Panel  
(Located inside the FRM  
compartment - lift lid to access)  
-Typical View

- Air Pressure Gauge
- Air Pressure Regulator

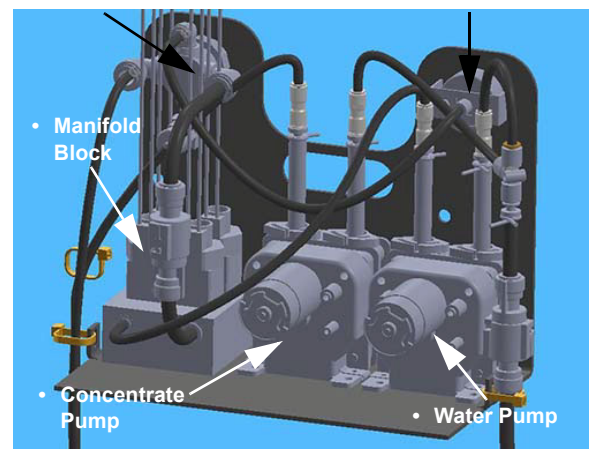

Foam Marker Control Panel  
(Close-up view)

### Pressure Adjustment

Air pressure may be adjusted by operating the Air Pressure Regulator (located on the Foam Marker Control Panel). Regulator air input comes from the air tank on the machine.

- Pull the Air Pressure Regulator OUT and rotate the dial in the “counter-clockwise” position to decrease pressure, or “clockwise” to increase pressure.

*NOTE: System pressure is displayed on the Air Pressure Gauge next to the Air Pressure Regulator.*

- Push the Air Pressure Regulator IN when finished adjusting pressure.

### Pressure Relief Valve

A Pressure Relief Valve is located on the back side of the Air Pressure Regulator to relieve excess pressure, if necessary.

- Pull the Pressure Relief Pull Ring OUT to open the valve and relieve system pressure.

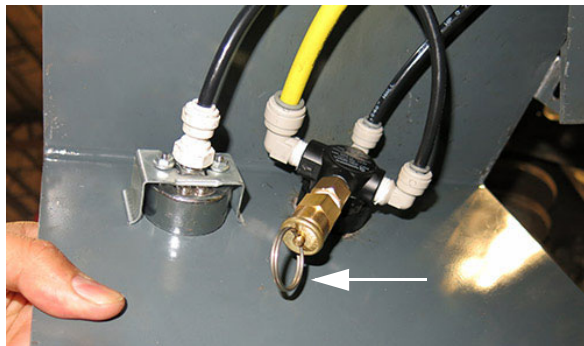

Pressure Relief Pull Ring  
(Located on the back side  
of the foam pressure regulator)  
-Typical View

### Foam Marker Frequency and Concentration

Foam Marker frequency and concentration levels are adjusted through the Machine Display. Refer to “Machine Display” in the *Cab Section* elsewhere in this manual for further information.

### Foam Drop Configuration

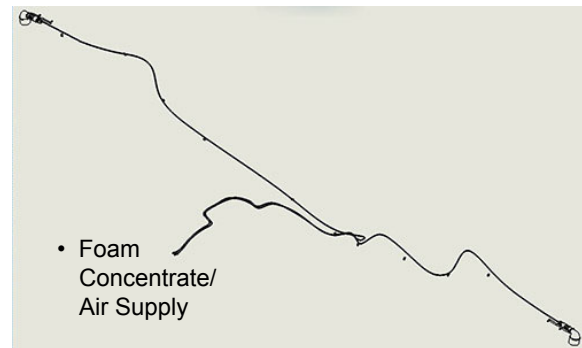

Foam Marker Plumbing Layout  
-Typical View



Foam Drop (2)  
-Typical View

## EDUCTOR SYSTEM

-If Equipped

### **⚠ CAUTION**

Agricultural chemicals can be dangerous. Improper selection or use can injure persons, animals, plants, soils or other property.

#### **TO AVOID INJURY**

1. Select the right chemical for the job.
2. Handle and apply it with care. Follow instructions issued by the chemical manufacturer.

N203265

### **⚠ CAUTION**

Wear the appropriate clothing and Personal Protective Equipment (PPE) when working with agricultural chemicals. Do not store chemical-soaked clothing inside the cab.

The Eductor System is used to mix and transfer chemical to the solution tanks after the carrier has been added to the tanks. This is done by utilizing the solution system pump to operate the Eductor's venturi.

The following information refers to components of the Eductor System and is not intended to replace the manufacturer's operating instructions.

### Eductor System Components

- (A) - Eductor Tank
- (B) - Eductor Tank Rinse Valve
- (C) - Stinger Valve
- (D) - Product Rinse Valve
- (E) - Venturi Valve
- (F) - Eductor Tank Valve
- (G) - Eductor Valve (2)

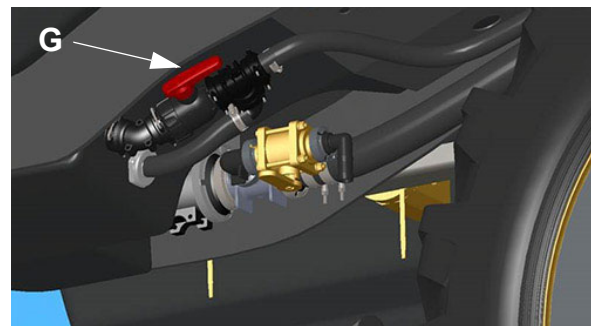
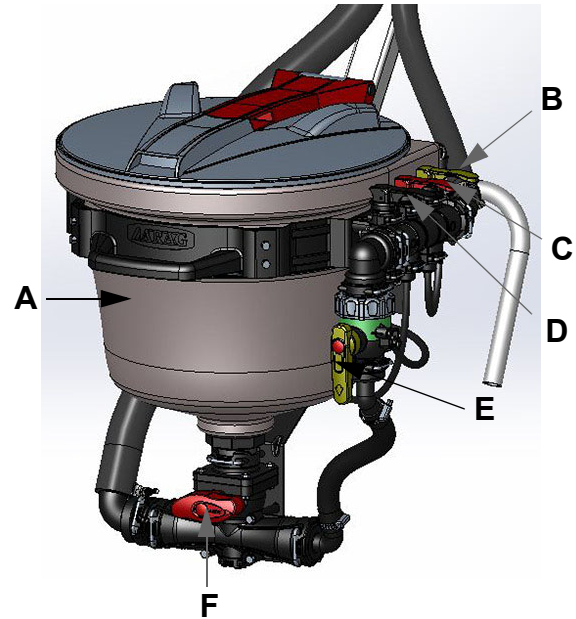

#### **Eductor Tank (A)**

- Capacity = 8 gallons (30L)
- Type = Polyethylene

#### **Eductor Tank Rinse Valve (B)**

The Eductor Tank Rinse Valve activates the internal flushing system to rinse the eductor tank after use.

#### **Stinger Valve (C)**

The Stinger Valve controls the flow to the spray (anti-clogging) nozzle that is pointed toward the bottom of the eductor tank to aid in breaking up clumps of dry product.

#### **Product Rinse Valve (D)**

The Product Rinse Valve controls the flow to the product rinse nozzle inside the eductor tank to thoroughly rinse the chemical container after use.

## SECTION 7 – SPRAY SYSTEMS



### Venturi Valve (E)

The Venturi Valve controls flow through the venturi (the tee-fitting located below the Eductor Tank Valve).

*NOTE: The Venturi Valve should remain closed unless the Eductor is in use.*

### Eductor Tank Valve (F)

The Eductor Tank Valve is used to pull chemical from the Eductor.

### Eductor Valve - 2 (G)

The Eductor Valves provide a low restriction path from the Eductor outlet to the solution tanks.

## Getting Started

**⚠ WARNING**

Ensure the eductor tank lid is closed before performing chemical mixing or rinsing. Operating with the lid open may result in serious injury.

**⚠ CAUTION**

Ensure the agitation valve is OFF before operating the Eductor. Failure to comply may result in serious injury.

1. Engage the parking brake.
2. Start the engine.
3. Press and hold the Agitation Valve Switch (located on the side console) in the DOWN position until the agitation valve is OFF.



Agitation Valve Switch  
(Located on the side console)  
-Typical View

*NOTE: Agitation Valve pressure is displayed on the Machine Display Home Page - Field Mode.*

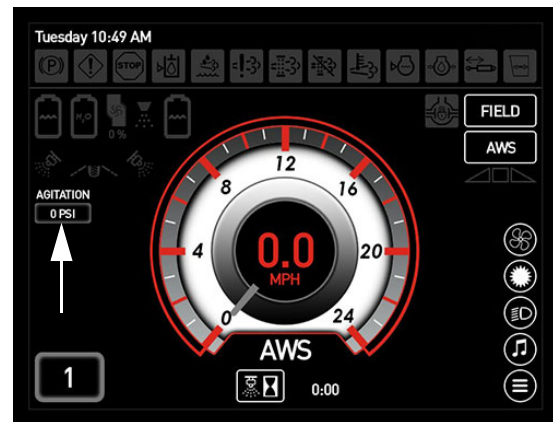

Agitation Valve Pressure Indicator  
(Located on the Machine Display Home Page - Field Mode)

4. Press the Solution Pump Switch (located on the side console) in the UP (On) position.

*NOTE: Do not run solution pump higher than 70%.*



## NOTICE

Do not allow the solution pump to run continuously while the boom solution valve switches are off. Failure to comply will generate overheating, causing severe pump damage and will void the warranty.



Solution Pump Switch  
(Located on the side console)  
-Typical View

*NOTE: A solution pump indicator is displayed on the Machine Display Home Page (Field Mode) and will illuminate when the solution pump is activated. In addition, solution pump pressure is displayed below the indicator.*

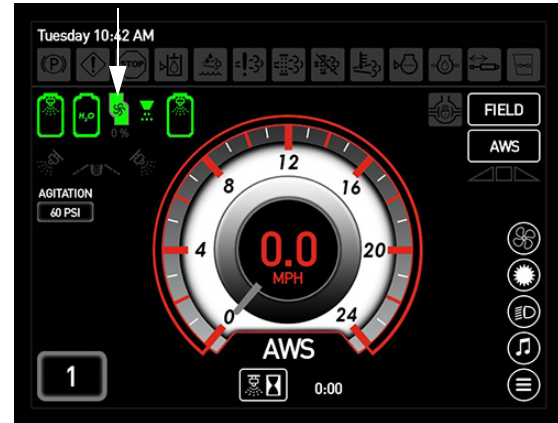

Solution Pump Indicator  
(Located on the Machine Display  
Home Page - Field Mode)

5. Rotate the Eductor Valves (located beneath each solution tank) in the OPEN (counter-clockwise) position.

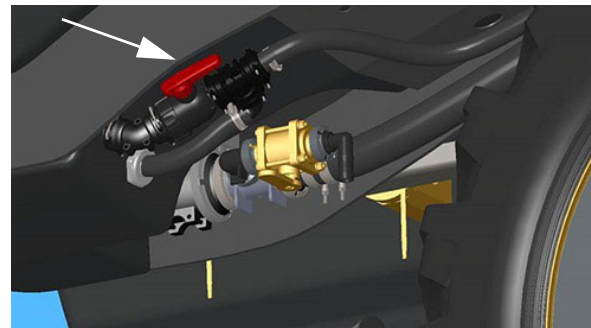

Eductor Valve (2)  
(Located beneath each solution tank)  
-Typical View

6. Rotate the Venturi Valve (located on the side of the eductor tank) in the OPEN (clockwise) position.

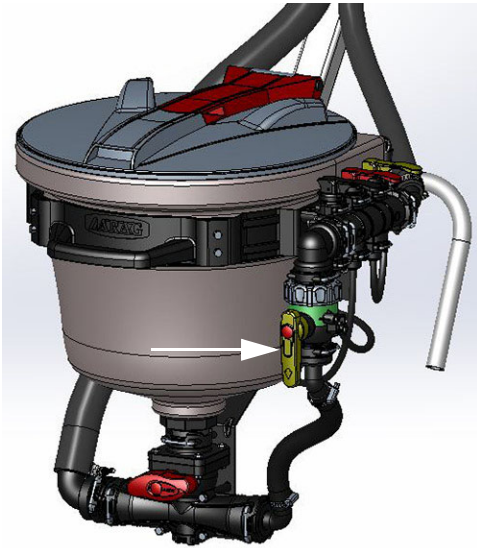

Venturi Valve  
(Located on the side of eductor tank)  
-Typical View

7. Open the eductor tank lid and add required amount of chemical.
8. Rotate the Eductor Tank Valve (located near the bottom of the eductor tank) in the OPEN (On) position.

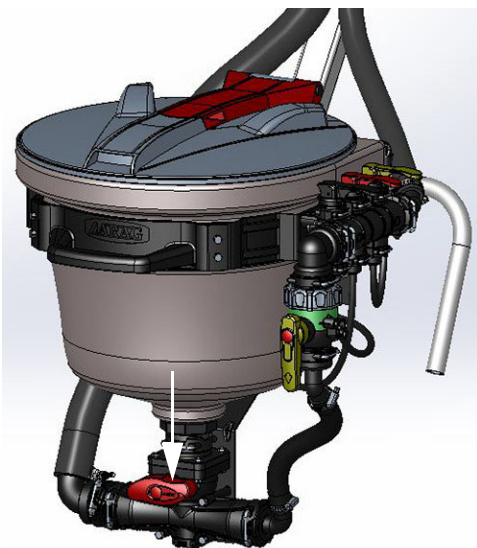

Eductor Tank Valve  
(Located near the bottom  
of the eductor tank)  
-Typical View

9. **When finished**, rotate the Eductor Tank Valve (located near the bottom of the

eductor tank) in the CLOSED (Off) position.

10. Rotate the Venturi Valve (located on the side of the eductor tank) in the CLOSED (counter-clockwise) position.
11. Rotate the Eductor Valves (located beneath each solution tank) in the CLOSED (clockwise) position.
12. Press the Solution Pump Switch (located on the side console) in the DOWN (Off) position.

### Rinsing the Chemical Container

**After all chemical product has been used, flush the container as follows:**

- Open the eductor tank lid and place chemical container upside-down on the internal jet, inserting it as much as possible in the container flushing nozzle.



Inserting Chemical Container  
on Flushing Nozzle  
-Typical View

- Keeping the container in position, lift and hold the black Product Rinse Valve (located on the side of the eductor tank) in the UP (On) position to activate the internal jet and flush the container.

*NOTE: Rinse the container three (3) times for approximately 15 seconds each time.*

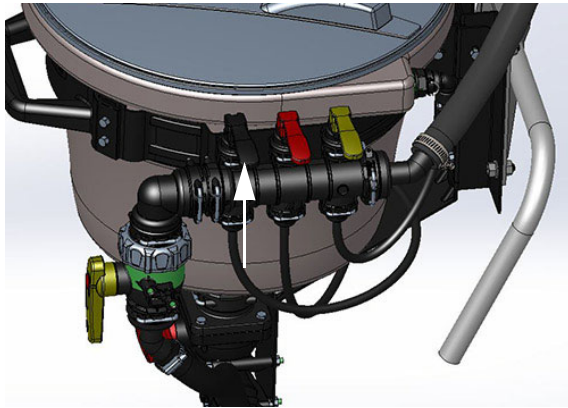

Product Rinse Valve  
(Located on the side of eductor tank)  
-Typical View

- When finished rinsing the container, release the black Product Rinse Valve.
- Remove chemical container and dispose of in compliance with current local laws.

### Rinsing the Eductor System

Rinse the eductor tank by operating the Eductor Tank Rinse Valve (B) and cycle all Eductor functions when rinsing the main solution tank.

### Further Information

Refer to the ARAG® manufacturer's operation manual for complete operating instructions, troubleshooting tips, safety precautions, and maintenance information.

## MODULAR INJECTION SYSTEM

-If Equipped

### **⚠ CAUTION**

Agricultural chemicals can be dangerous. Improper selection or use can injure persons, animals, plants, soils or other property.

#### **TO AVOID INJURY**

1. Select the right chemical for the job.
2. Handle and apply it with care. Follow instructions issued by the chemical manufacturer.

N203265

### **⚠ CAUTION**

Wear the appropriate clothing and Personal Protective Equipment (PPE) when working with agricultural chemicals. Do not store chemical-soaked clothing inside the cab.

The direct Modular Injection System can be ordered and installed during production or aftermarket on DTS10 machines. The system is offered in the following configurations:

- One Chemical Tank/One Injection Pump
- Two Chemical Tanks/Two Injection Pumps

*NOTE: Chemical Tank Capacity = 45 gallons (170 L)/each.*

This system allows the operator to quickly change from one chemical to another without rinsing the main tank in between. Chemical application rate can also be adjusted by concentration variation, which improves application efficiency.

## SECTION 7 – SPRAY SYSTEMS



The Modular Injection System accurately injects concentrated chemical, where it is then mixed with water (stored in the main tanks) just prior to being applied. Therefore, there is no need to pre-mix chemicals beforehand. There is also no need to dispose of any remaining chemical mixture at the end of use, as unused chemical may remain stored in the chemical tank(s).

The concentrated chemical is extracted from the chemical tank, where it is then sent to the in-line suction strainer, and then routed to the injection pump. From there it is sent to the flow indicator (mounted on the outside of cab), and then to the mixer assembly (where the chemical is mixed with water). From the mixer assembly, the solution is then applied through the spray booms.

The following information refers to components of the Modular Injection System and is not intended to replace the manufacturer's operating instructions.

### Modular Injection System Components

- (A) - Main Tanks (2)
- (B) - Chemical Tank(s)
- (C) - Injection Pump(s)
- (D) - Outlet Selector Valve(s)
- (E) - Inlet Selector Valve(s)
- (F) - In-Line Suction Strainer(s)
- (G) - Valve Orientation Label
- (H) - Tank Drain Valve(s)
- (I) - Tank Drain Outlet(s)
- (J) - Flow Indicator(s)
- (K) - Mixer Assembly

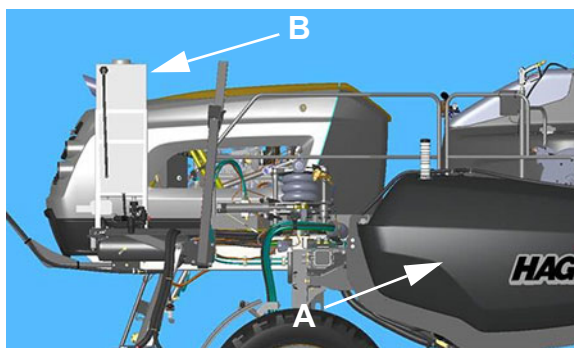
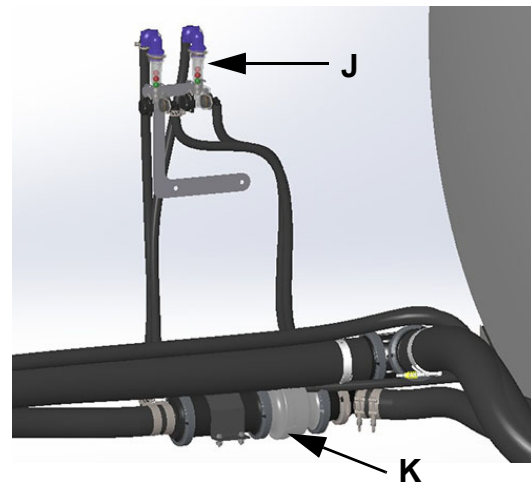
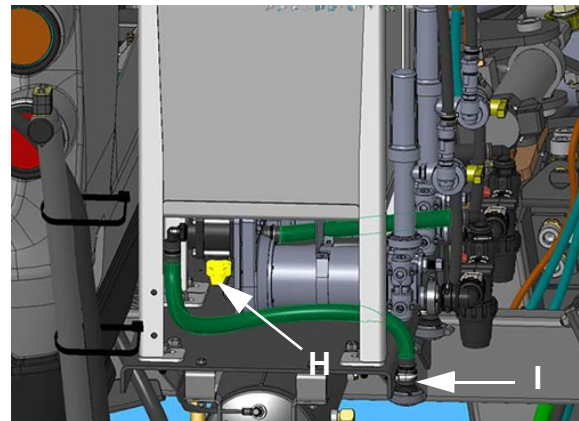
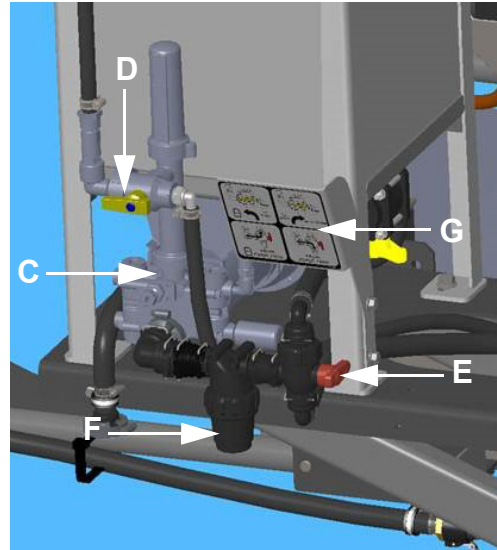

### 3-Way Valve Handle Flow Positions

Refer to the following illustration to determine correct valve handle orientation when operating the various 3-way valves with this system.

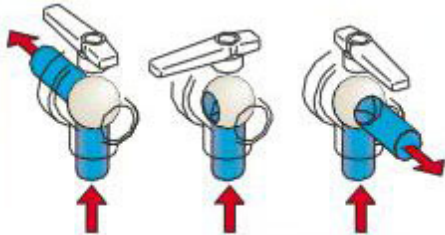

### Filling the Chemical Tank(s)

1. Ensure the Tank Drain Valve (located beneath the chemical tank) is in the CLOSED (Off) position.

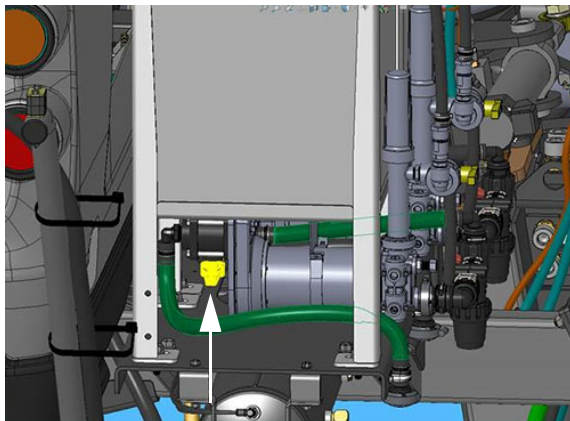

Tank Drain Valve  
(Located beneath the chemical tank)  
-Typical View

2. Remove the Fill Port Lid (located on top of the chemical tank) and set aside.

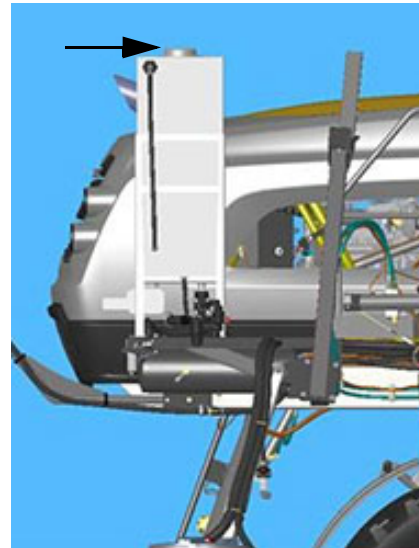

Fill Port Lid  
(Located on top of chemical tank)  
-Typical View

3. Pour product through fill port and fill chemical tank to desired level.
4. Reinstall the Fill Port Lid.
5. Repeat steps to fill additional chemical tank - *if equipped*.

### Getting Started

## NOTICE

Never attempt to operate the Modular Injection System without solution in the tank(s). Failure to comply may result in equipment damage and will void the warranty.

*NOTE: Ensure the Master Spray Switch (located on the Hydrostatic Drive Control Handle) is in the OFF position before activating the Solution Pump Switch or the Boom Solution Valve Switches, unless you are ready to begin spray application.*

1. Calibrate the spray system console (refer to the manufacturer's operation manual for calibration instructions).

## SECTION 7 – SPRAY SYSTEMS



2. Ensure there is adequate amount of solution in the chemical tank(s) and water in the main tanks.
3. Rotate the Outlet Selector Valve(s) (located on the front of injection pump(s)) to the “TO BOOM” position.

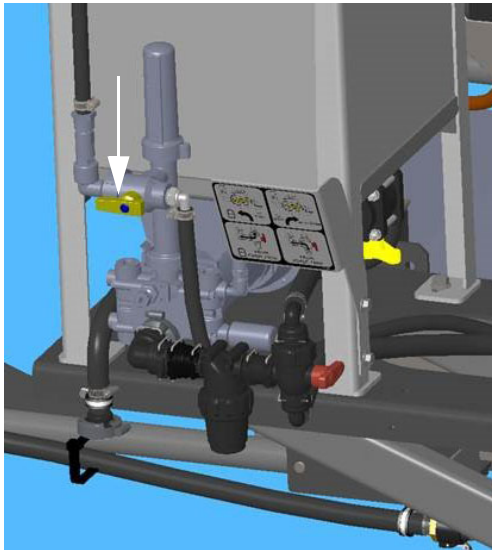

Outlet Selector Valve(s)  
(Located on the front of injection pump(s))  
-Typical View

\* 1-tank/1-pump configuration show

**NOTE:** Refer to the provided label for valve handle orientation. See following illustration.

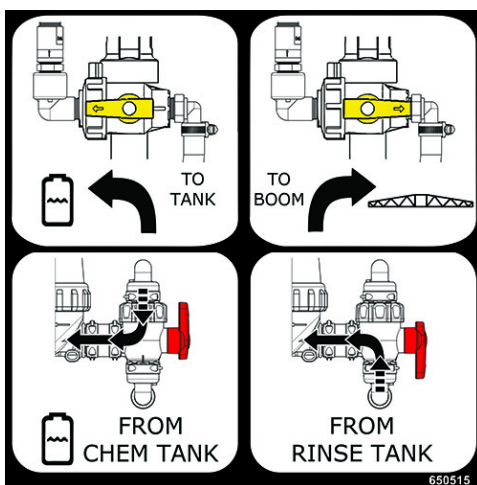

4. Rotate the Inlet Selector Valve(s) (located near the bottom right-hand side of chemical tank(s)) to the “FROM CHEM TANK” position.

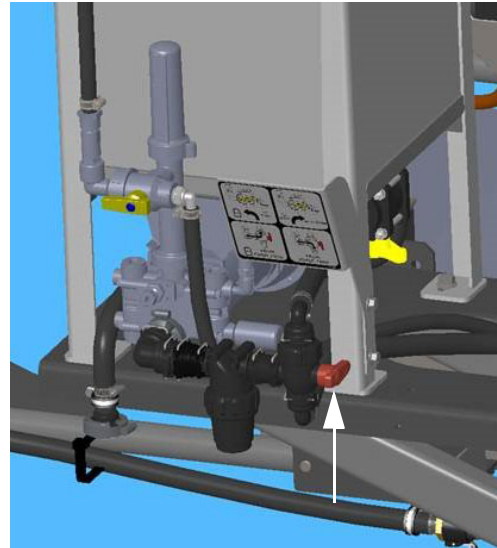

Inlet Selector Valve(s)  
(Located near the bottom  
right-hand side of chemical tank(s))  
-Typical View

\* 1-tank/1-pump configuration show

5. Engage the parking brake.
6. Start the engine.
7. Press the Field/Road Button (located on the Machine Display Home Page) and change the machine’s drive state to FIELD.

**NOTE:** The drive state of the machine cannot be changed unless the Hydrostatic Drive Control Handle is in the NEUTRAL position (and machine speed is less than 0.5 mph/ 0.8 km/h).

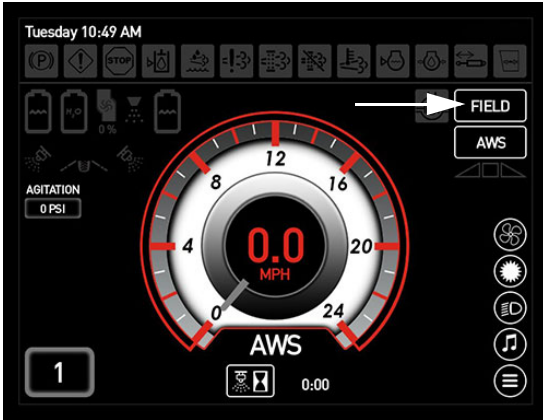

Field/Road Button  
(Located on the  
Machine Display Home Page)

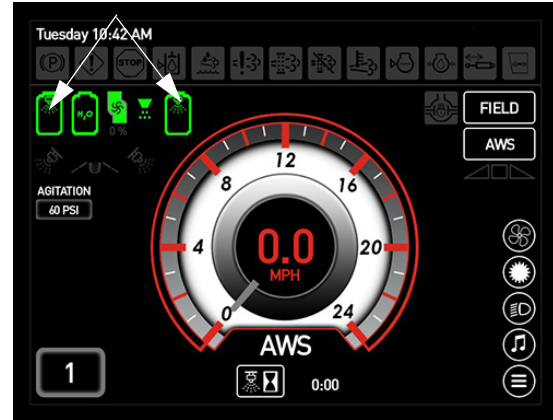

Main Tank Indicators  
(Located on the Machine Display  
Home Page - Field Mode)

8. Position boom to desired position.
9. Press the Tank Valve Selector Switch(es) - Left/Right (located on the side console) in the UP (Main Tank) position.



Tank Valve Selector Switches - Left/Right  
(Located on the side console)  
-Typical View

10. Press desired Rate Control Switch (located on the side console).
  - Press ENABLE to allow the rate controller to control application rate.
  - Press MAN (Manual) to control application rate from the section keypad.
  - Press ENABLE and MAN to enable manual rate control through the rate controller.

*NOTE: When “MAN” is selected, press the Pump Speed/Rate Switches (located on the side console) to increase (+) or decrease (-) application rate. Current solution pump speed is displayed below the Solution Pump Indicator (located on the Machine Display Home Page - Field Mode).*

*NOTE: Increasing or decreasing pump speed will change the application rate through the rate controller.*

*NOTE: Main Tank Valve status is displayed on the Machine Display Home Page (Field Mode).*

## SECTION 7 – SPRAY SYSTEMS



Rate Control and  
Pump Speed/Rate Switches  
(Located on the side console)  
-Typical View

11. Press the Solution Pump Switch (located on the side console) in the UP (On) position.



Solution Pump Switch  
(Located on the side console)  
-Typical View

12. Turn the Master Spray Switch (located on the Hydrostatic Drive Control Handle) ON.

### NOTICE

Do not allow the Solution Pump to run continuously while the Boom Solution Valve Switches are off. Failure to comply will generate overheating, causing severe pump damage and will void the warranty.



Master Spray Switch  
(Located on the Hydrostatic  
Drive Control Handle)  
-Typical View

*NOTE: When the Master Spray Switch is ON, a Master Spray Indicator (located on the Machine Display Home Page - Field Mode) will illuminate.*



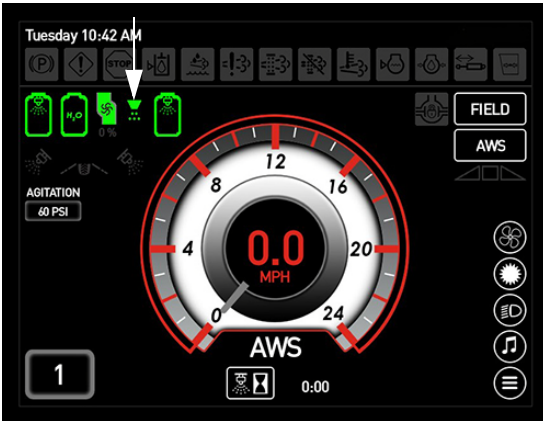

Master Spray Indicator  
(Located on the Machine Display  
Home Page - Field Mode)

13. Press the individual Boom Solution Valve Switches (located on the side console) to the ON (non-illuminated) position.

*NOTE: Each Boom Solution Valve Switch is equipped with an indicator light and will illuminate when the corresponding Boom Solution Valve is OFF.*



Boom Solution Valve Switches  
(Located on the side console)  
-Typical View

14. Slowly move the Hydrostatic Drive Control Handle forward to obtain desired ground speed.
15. Frequently observe the pressure gauge. If the pressure drops to zero or spray pattern deteriorates, turn OFF the Master Spray, Solution Pump Switch, and

Tank Valve Selector Switches until solution is refilled.

### Injection Pump Calibration

1. Calibrate the Injection Pump(s) (located near the bottom of chemical tank(s)).

*NOTE: Refer to the Raven manufacturer's operation manual for information on injection pump calibration.*

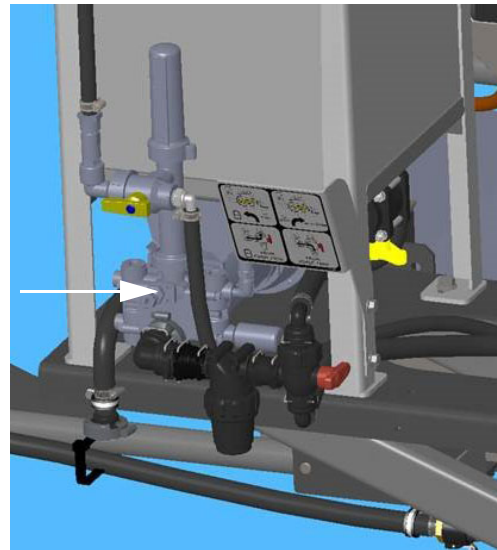

Injection Pump(s)  
(Located near the bottom  
of chemical tank(s))  
-Typical View

\* 1-tank/1-pump configuration shown

2. Rotate the Inlet Selector Valve(s) (located near the bottom right-hand side of chemical tank(s)) to the "FROM CHEM TANK" position.

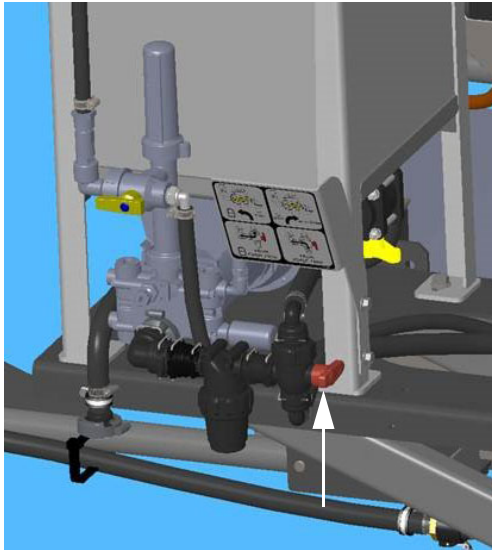

**Inlet Selector Valve(s)**  
(Located near the bottom  
right-hand side of chemical tank(s))  
-Typical View

\* 1-tank/1-pump configuration show

3. Rotate the Outlet Selector Valve(s) (located on the front of injection pump(s)) to the "TO TANK" position. This will allow the chemical to divert back to the tank rather than the booms during the calibration process.

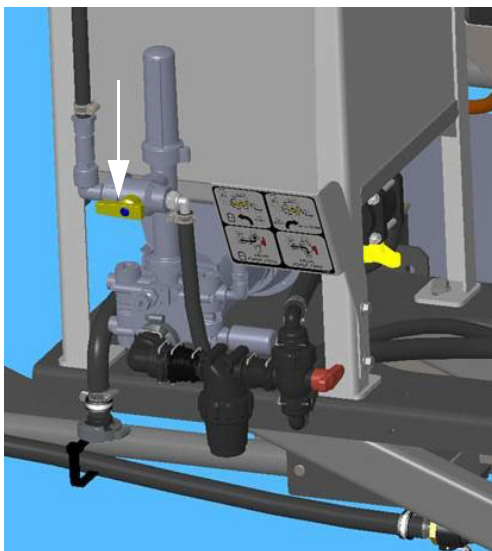

**Outlet Selector Valve(s)**  
(Located on the front of injection pump(s))  
-Typical View

\* 1-tank/1-pump configuration show

*NOTE: Refer to the provided label for valve handle orientation. See following illustration.*

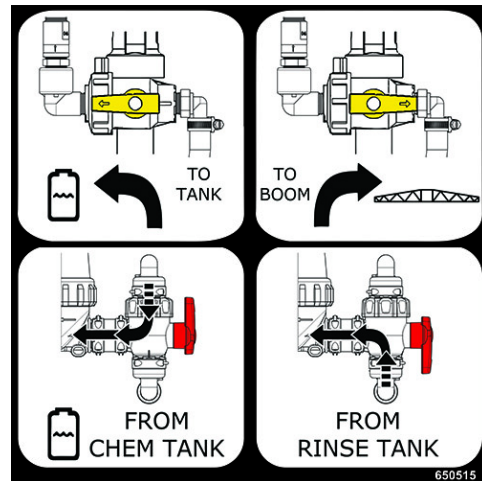

4. When pump calibration is complete, rotate the Outlet Selector Valve(s) to the "TO BOOM" position to send chemical to the Mixer Assembly.

**In-Line Suction Strainers  
(80-Mesh Strainer Screen)**

**⚠ CAUTION**

Before removing the in-line suction strainer(s), ensure the Inlet Selector Valve(s) is in the CLOSED (Off) position. Failure to comply may result in chemical contact.

An In-Line Suction Strainer (located in front of injection pump(s)) is provided to reduce the possibility of debris from contaminating the system. With the Inlet Selector Valve(s) (located near the bottom right-hand side of chemical tank(s)) in the CLOSED (Off) position, remove cap and clean strainer screen periodically to ensure adequate flow.

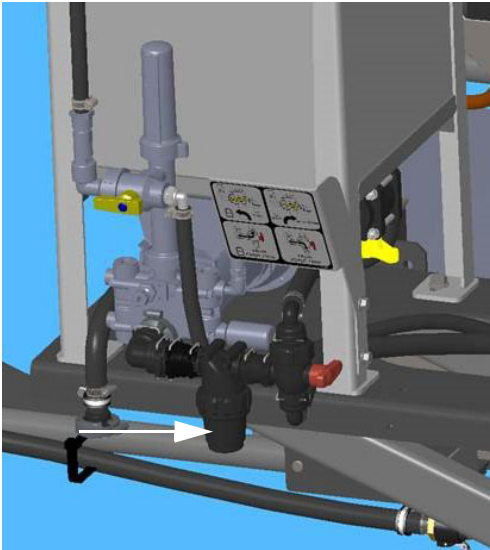

**In-Line Suction Strainer(s)**  
(Located in front of injection pump(s))  
-Typical View  
*\* 1-tank/1-pump configuration shown*

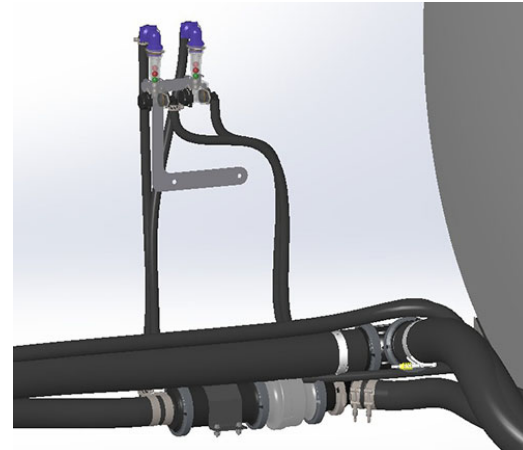

**Flow Indicators**  
(Located on the exterior  
right-hand side of cab)  
-Typical View  
*\* 2-pump configuration shown*

## Flow Indicators

### NOTICE

Flow Indicators are not provided as a means to determine an accurate measurement of flow. It is the responsibility of the operator to calibrate the injection pump(s) and choose the correct indicator ball for each product.

Flow Indicators (one per injection pump) are visible from inside the cab and allow the operator to monitor solution flow at all times, as well as ensure the injection pump is operating correctly and what product is flowing.

## Rinsing the Supply Lines and Injection Pump(s)

If chemical remains in the tank(s) at the end of the day, it is recommended to rinse chemical from the supply lines and injection pump(s). To accomplish this:

1. Rotate the Inlet Selector Valve(s) (located near the bottom right-hand side of chemical tank(s)) to the "FROM RINSE TANK" position to rinse the Injection Pump(s). This will allow fresh water from the rinse tank to flow through and flush the lines and pump(s).

**Draining the Chemical Tank(s)**

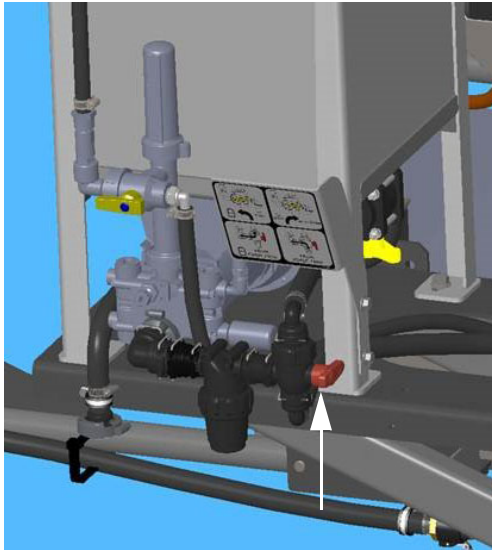

**Inlet Selector Valve(s)**  
(Located near the bottom  
right-hand side of chemical tank(s))  
-Typical View

\* 1-tank/1-pump configuration show

*NOTE: Refer to the provided label for valve  
handle orientation. See following  
illustration.*

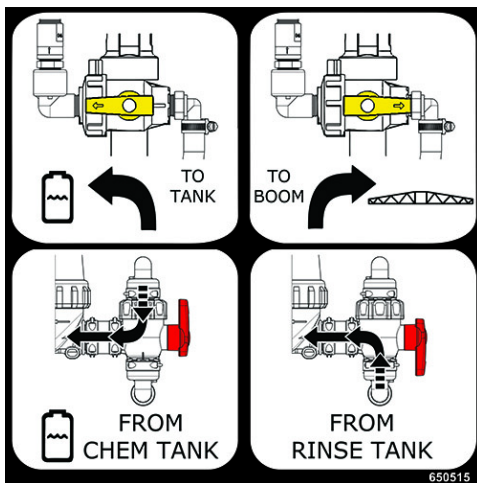

2. Run the Injection Pump(s) with the Outlet Selector Valve(s) (located on the front of injection pump(s)) in the “TO BOOM” position.

NOTICE

Drain chemicals into an adequately sized and clearly labeled container, ensuring lid is tightly closed.

1. Ensure the Tank Drain Valve (located beneath the chemical tank) is in the CLOSED (Off) position.

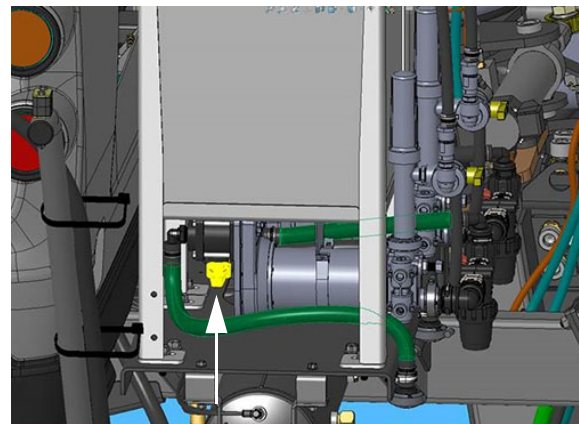

**Tank Drain Valve**  
(Located beneath the chemical tank)  
-Typical View

2. Loosen the metal flange clamp and remove cap from the bottom of the Tank Drain Outlet (located beneath machine near chemical tank).

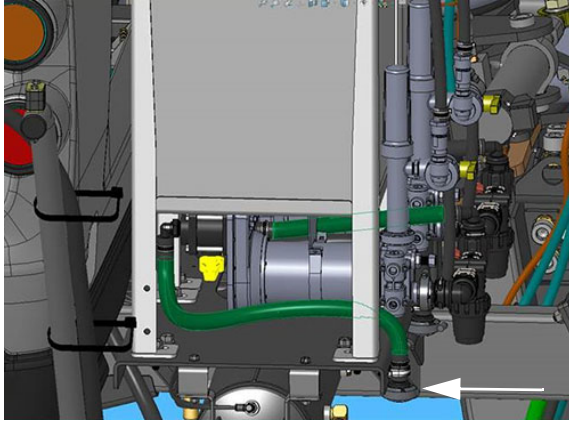

Tank Drain Outlet  
(Located beneath machine  
near chemical tank)  
-Typical View

3. Rotate the Tank Drain Valve to the OPEN (On) position (away from injection pump) to drain chemical.
4. **When finished draining tank**, rotate the Tank Drain Valve to the CLOSED (Off) position.
5. Reinstall cap and metal flange on the Tank Drain Outlet.
6. Repeat steps to drain additional chemical tank - *if equipped* (using the corresponding tank drain valves).

### Further Information

Refer to the Raven manufacturer's operation manual for complete operating and calibration instructions, troubleshooting tips, safety precautions, and maintenance information.

---

## APPLICATION

It is important to apply chemicals as recommended by the manufacturer. In order to do so, the spray system console must be properly calibrated.

*NOTE: Refer to the spray system console manufacturer's operation manual for calibration instructions.*

Determine the speed in which the sprayer will travel when applying chemicals. To select the best speed, consider the lay of the land, condition of the soil, type of crop, height of crop, etc.

Remember that the performance of the nozzles (spray tips) and spray system are dependent on the performance of the operator. If the spray system is operated within set parameters of the nozzle type and spray system console, you will see greater success with your application. Operating the machine one or two miles per hour (1.6 to 3.2 km/h) faster or slower than intended can greatly change the pressure and droplet size.

Select nozzle spacing (distance between each nozzle on the spray boom) that is best suited for the intended spray application. For recommendation in determining nozzle spacing and height of the boom, visit [www.teejet.com](http://www.teejet.com) for further information.

There are various types and sizes of nozzles. Select and install the appropriate nozzle best suited for the intended spray application. The type of nozzle will depend on the product being applied and the type of crop that it is being used on. The size of nozzles selected will be based on the speed in which the machine will travel, nozzle spacing, desired droplet size, and the number of gallons per acre (GPA)/liters per hectare (l/ha) that will be applied.

### Nozzle Selection

There are several things to consider when selecting the correct nozzle type for the intended spray application. Whatever your personal preference is, ensure that the nozzle complies with the chemical manufacturer's standards for spray control and also any environmental standards for your region.

*NOTE: Certain regions may have restrictions on drift control.*

Once you have selected the type of nozzle, you must choose the size of the nozzle. There are three main things to consider when choosing a nozzle size:

1. Recommendation of GPA (l/ha).

## SECTION 7 – SPRAY SYSTEMS



2. The speed in which you intend to travel when applying chemical and nozzle spacing (distance between nozzles).
3. Spray Tip size (refer to the following example on how to select a proper tip size).

The following Application Rate Chart provides tabulations based on spraying water. When spraying liquids other than water, you will need to use a conversion factor to configure the appropriate application rates.

### Example of how to choose the proper nozzle:

Joe is spraying 28% nitrogen. The chemical manufacturer recommends that the chemical be applied at 20 gallons per acre (GPA)/187 liters per hectare (l/ha). Joe knows that he can run his sprayer at 10 mph (16 km/h) across the field. He has 20-inch (50 cm) nozzle spacing on his booms. Joe has narrowed his tip search to flat spray tips.

Use the following conversion formula:

$$\text{GPM} = \frac{\text{GPA} \times \text{MPH} \times \text{Nozzle Spacing}}{5940 \text{ (Constant)}}$$

$$\text{l/min} = \frac{\text{l/ha} \times \text{km/h} \times \text{Nozzle Spacing}}{60,000}$$

### Examples:

$$\text{GPM} = \frac{22.6 \times 10 \times 20}{5940} = \frac{4520}{5940} = 0.76 \text{ GPM (per nozzle)}$$

$$\text{l/min} = \frac{211.3 \times 16 \times 50}{60,000} = \frac{169040}{60,000} = 2.82 \text{ l/min (per nozzle)}$$

- **20 GPA (187 l/ha) (liquid other than water) x 1.13 (conversion factor) = 22.6 GPA (211.3 l/ha) (water).**

Joe determined that he needs an application rate of 22.6 GPA (211.3 l/ha) to select the correct nozzle to apply 28% nitrogen at 20 GPA (187 l/ha).

To determine which nozzle is better for his intended use, Joe needs to figure out the gallons per minute (GPM)/liters per minute (l/min) each nozzle needs to spray.

**English to Metric Conversion**

- Gallons per Acre (GPA) x 9.354 = Liters per Hectare (l/ha)
- Gallons per Minute (GPM) x 3.785 = Liters per Minute (l/min)

**Metric to English Conversion**

- Liters per Hectare (l/ha) x .1069 = Gallons per Acre (GPA)
- Liters per Minute (l/min) x .26 = Gallons per Minute (GPM)

*NOTE: Always double check your application rates. The following tabulations are based on spraying water at 70° F./21° C.*

**SECTION 7 –  
SPRAY SYSTEMS**



Standard Application Rate Chart												
				Gallons per Acre (GPA) - 15" Nozzle Spacing								
Tip Cap.	Liquid Pressure (PSI)	Cap. 1 Nozzle (GPM)	Cap. 1 Nozzle (Oz./Min.)	4 mph	6 mph	8 mph	10 mph	12 mph	14 mph	16 mph	18 mph	20 mph
01	15	0.061	7.8	6.0	4.0	3.0	2.4	2.0	1.7	1.5	1.3	1.2
	20	0.071	9.1	7.0	4.7	3.5	2.8	2.3	2.0	1.8	1.6	1.4
	30	0.087	11	8.6	5.7	4.3	3.4	2.9	2.5	2.2	1.9	1.7
	40	0.10	13	9.9	6.6	5.0	4.0	3.3	2.8	2.5	2.2	2.0
	50	0.11	14	10.9	7.3	5.4	4.4	3.6	3.1	2.7	2.4	2.2
	60	0.12	15	11.9	7.9	5.9	4.8	4.0	3.4	3.0	2.6	2.4
	75	0.14	18	13.9	9.2	6.9	5.5	4.6	4.0	3.5	3.1	2.8
	90	0.15	19	14.9	9.9	7.4	5.9	5.0	4.2	3.7	3.3	3.0
015	15	0.092	12	9.1	6.1	4.6	3.6	3.0	2.6	2.3	2.0	1.8
	20	0.11	14	10.9	7.3	5.4	4.4	3.6	3.1	2.7	2.4	2.2
	30	0.13	17	12.9	8.6	6.4	5.1	4.3	3.7	3.2	2.9	2.6
	40	0.15	19	14.9	9.9	7.4	5.9	5.0	4.2	3.7	3.3	3.0
	50	0.17	22	16.8	11.2	8.4	6.7	5.6	4.8	4.2	3.7	3.4
	60	0.18	23	17.8	11.9	8.9	7.1	5.9	5.1	4.5	4.0	3.6
	75	0.21	27	21	13.9	10.4	8.3	6.9	5.9	5.2	4.6	4.2
	90	0.23	29	23	15.2	11.4	9.1	7.6	6.5	5.7	5.1	4.6
02	15	0.12	15	11.9	7.9	5.9	4.8	4.0	3.4	3.0	2.6	2.4
	20	0.14	18	13.9	9.2	6.9	5.5	4.6	4.0	3.5	3.1	2.8
	30	0.17	22	16.8	11.2	8.4	6.7	5.6	4.8	4.2	3.7	3.4
	40	0.20	26	19.8	13.2	9.9	7.9	6.6	5.7	5.0	4.4	4.0
	50	0.22	28	22	14.5	10.9	8.7	7.3	6.2	5.4	4.8	4.4
	60	0.24	31	24	15.8	11.9	9.5	7.9	6.8	5.9	5.3	4.8
	75	0.27	35	27	17.8	13.4	10.7	8.9	7.6	6.7	5.9	5.3
	90	0.30	38	30	19.8	14.9	11.9	9.9	8.5	7.4	6.6	5.9
025	15	0.15	19	14.9	9.9	7.4	5.9	5.0	4.2	3.7	3.3	3.0
	20	0.18	23	17.8	11.9	8.9	7.1	5.9	5.1	4.5	4.0	3.6
	30	0.22	28	22	14.5	10.9	8.7	7.3	6.2	5.4	4.8	4.4
	40	0.25	32	25	16.5	12.4	9.9	8.3	7.1	6.2	5.5	5.0
	50	0.28	36	28	18.5	13.9	11.1	9.2	7.9	6.9	6.2	5.5
	60	0.31	40	31	20	15.3	12.3	10.2	8.8	7.7	6.8	6.1
	75	0.34	44	34	22	16.8	13.5	11.2	9.6	8.4	7.5	6.7
	90	0.38	49	38	25	18.8	15.0	12.5	10.7	9.4	8.4	7.5





## SECTION 7 – SPRAY SYSTEMS

03	15	0.18	23	17.8	11.9	8.9	7.1	5.9	5.1	4.5	4.0	3.6
	20	0.21	27	21	13.9	10.4	8.3	6.9	5.9	5.2	4.6	4.2
	30	0.26	33	26	17.2	12.9	10.3	8.6	7.4	6.4	5.7	5.1
	40	0.30	38	30	19.8	14.9	11.9	9.9	8.5	7.4	6.6	5.9
	50	0.34	44	34	22	16.8	13.5	11.2	9.6	8.4	7.5	6.7
	60	0.37	47	37	24	18.3	14.7	12.2	10.5	9.2	8.1	7.3
	75	0.41	52	41	27	20	16.2	13.5	11.6	10.1	9.0	8.1
	90	0.45	58	45	30	22	17.8	14.9	12.7	11.1	9.9	8.9
04	15	0.24	31	24	15.8	11.9	9.5	7.9	6.8	5.9	5.3	4.8
	20	0.28	36	28	18.5	13.9	11.1	9.2	7.9	6.9	6.2	5.5
	30	0.35	45	35	23	17.3	13.9	11.6	9.9	8.7	7.7	6.9
	40	0.40	51	40	26	19.8	15.8	13.2	11.3	9.9	8.8	7.9
	50	0.45	58	45	30	22	17.8	14.9	12.7	11.1	9.9	8.9
	60	0.49	63	49	32	24	19.4	16.2	13.9	12.1	10.8	9.7
	75	0.55	70	54	36	27	22	18.2	15.6	13.6	12.1	10.9
	90	0.60	77	59	40	30	24	19.8	17.0	14.9	13.2	11.9
05	15	0.31	40	31	20	15.3	12.3	10.2	8.8	7.7	6.8	6.1
	20	0.35	45	35	23	17.3	13.9	11.6	9.9	8.7	7.7	6.9
	30	0.43	55	43	28	21	17.0	14.2	12.2	10.6	9.5	8.5
	40	0.50	64	50	33	25	19.8	16.5	14.1	12.4	11.0	9.9
	50	0.56	72	55	37	28	22	18.5	15.8	13.9	12.3	11.1
	60	0.61	78	60	40	30	24	20	17.3	15.1	13.4	12.1
	75	0.68	87	67	45	34	27	22	19.2	16.8	15.0	13.5
	90	0.75	96	74	50	37	30	25	21	18.6	16.5	14.9
06	15	0.37	47	37	24	18.3	14.7	12.2	10.5	9.2	8.1	7.3
	20	0.42	54	42	28	21	16.6	13.9	11.9	10.4	9.2	8.3
	30	0.52	67	51	34	26	21	17.2	14.7	12.9	11.4	10.3
	40	0.60	77	59	40	30	24	19.8	17.0	14.9	13.2	11.9
	50	0.67	86	66	44	33	27	22	19.0	16.6	14.7	13.3
	60	0.73	93	72	48	36	29	24	21	18.1	16.1	14.5
	75	0.82	105	81	54	41	32	27	23	20	18.0	16.2
	90	0.90	115	89	59	45	36	30	25	22	19.8	17.8
08	15	0.49	63	49	32	24	19.4	16.2	13.9	12.1	10.8	9.7
	20	0.57	73	56	38	28	23	18.8	16.1	14.1	12.5	11.3
	30	0.69	88	68	46	34	27	23	19.5	17.1	15.2	13.7
	40	0.80	102	79	53	40	32	26	23	19.8	17.6	15.8
	50	0.89	114	88	59	44	35	29	25	22	19.6	17.6
	60	0.98	125	97	65	49	39	32	28	24	22	19.4
	75	1.10	141	109	73	54	44	36	31	27	24	22
	90	1.20	154	119	79	59	48	40	34	30	26	24
10	15	0.61	78	60	40	30	24	20	17.3	15.1	13.4	12.1
	20	0.71	91	70	47	35	28	23	20	17.6	15.6	14.1
	30	0.87	111	86	57	43	34	29	25	22	19.1	17.2
	40	1.00	128	99	66	50	40	33	28	25	22	19.8
	50	1.12	143	111	74	55	44	37	32	28	25	22
	60	1.22	156	121	81	60	48	40	35	30	27	24
	75	1.37	175	136	90	68	54	45	39	34	30	27
	90	1.50	192	149	99	74	59	50	42	37	33	30

**SECTION 7 –  
SPRAY SYSTEMS**



15	15	0.92	118	91	61	46	36	30	26	23	20	18.2
	20	1.06	136	105	70	52	42	35	30	26	23	21
	30	1.30	166	129	86	64	51	43	37	32	29	26
	40	1.50	192	149	99	74	59	50	42	37	33	30
	50	1.68	215	166	111	83	67	55	48	42	37	33
	60	1.84	236	182	121	91	73	61	52	46	40	36
	75	2.05	262	203	135	101	81	68	58	51	45	41
	90	2.25	288	223	149	111	89	74	64	56	50	45
20	15	1.22	156	121	81	60	48	40	35	30	27	24
	20	1.41	180	140	93	70	56	47	40	35	31	28
	30	1.73	221	171	114	86	69	57	49	43	38	34
	40	2.00	256	198	132	99	79	66	57	50	44	40
	50	2.24	287	222	148	111	89	74	63	55	49	44
	60	2.45	314	243	162	121	97	81	69	61	54	49
	75	2.74	351	271	181	136	109	90	78	68	60	54
	90	3.00	384	297	198	149	119	99	85	74	66	59

Metric Application Rate Chart													
			Liters per Hectare (l/ha) - 40 cm Nozzle Spacing										
Tip Cap.	Liquid Press. (Bar)	Cap. 1 Nozzle (l/min)	4 km/h	6 km/h	8 km/h	10 km/h	12 km/h	14 km/h	16 km/h	18 km/h	20 km/h	25 km/h	30 km/h
01	1.0	0.23	86.3	57.5	43.1	34.5	28.8	24.6	21.6	19.2	17.3	13.8	11.5
	1.5	0.28	105	70.0	52.5	42.0	35.0	30.0	26.3	23.3	21.0	16.8	14.0
	2.0	0.32	120	80.0	60.0	48.0	40.0	34.3	30.0	26.7	24.0	19.2	16.0
	3.0	0.39	146	97.5	73.1	58.5	48.8	41.8	36.6	32.5	29.3	23.4	19.5
	4.0	0.45	169	113	84.4	67.5	56.3	48.2	42.2	37.5	33.8	27.0	22.5
	5.0	0.50	188	125	93.8	75.0	62.5	53.6	46.9	41.7	37.5	30.0	25.0
	6.0	0.55	206	138	103	82.5	68.8	58.9	51.6	45.8	41.3	33.0	27.5
	7.0	0.60	225	150	113	90.0	75.0	64.3	56.3	50.0	45.0	36.0	30.0
015	1.0	0.34	128	85	63.8	51.0	42.5	36.4	31.9	28.3	25.5	20.4	17.0
	1.5	0.42	158	105	78.8	63.0	52.5	45.0	39.4	35.0	31.5	25.2	21.0
	2.0	0.48	180	120	90.0	72.0	60.0	51.4	45.0	40.0	36.0	28.8	24.0
	3.0	0.59	221	148	111	88.5	73.8	63.2	55.3	49.2	44.3	35.4	29.5
	4.0	0.68	255	170	128	102	85.0	72.9	63.8	56.7	51.0	40.8	34.0
	5.0	0.76	285	190	143	114	95.0	81.4	71.3	63.3	57.0	45.6	38.0
	6.0	0.83	311	208	156	125	104	88.9	77.8	69.2	62.3	49.8	41.5
	7.0	0.90	338	225	169	135	113	96.4	84.4	75.0	67.5	54.0	45.0
02	1.0	0.46	173	115	86.3	69.0	57.5	49.3	43.1	38.3	34.5	27.6	23.0
	1.5	0.56	210	140	105	84.0	70.0	60.0	52.5	46.7	42.0	33.6	38.0
	2.0	0.65	244	163	122	97.5	81.3	69.6	60.9	54.2	48.8	39.0	32.5
	3.0	0.79	296	198	148	119	98.8	84.6	74.1	65.8	59.3	47.4	39.5
	4.0	0.91	341	228	171	137	114	97.5	85.3	75.8	68.3	54.6	45.5
	5.0	1.02	383	255	191	153	128	109	95.6	85.0	76.5	61.2	51.0
	6.0	1.12	420	280	210	168	140	120	105	93.3	84.0	67.2	56.0
	7.0	1.21	454	303	227	182	151	130	113	101	90.8	72.6	60.5
025	1.0	0.57	214	143	107	85.5	71.3	61.1	53.4	47.5	42.8	34.2	28.5
	1.5	0.70	263	175	131	105	87.5	75.0	65.6	58.3	52.5	42.0	35.0
	2.0	0.81	304	203	152	122	101	86.8	75.9	67.5	60.8	48.6	40.5
	3.0	0.99	371	248	186	149	124	106	92.8	82.5	74.3	59.4	49.5
	4.0	1.14	428	285	214	171	143	122	107	95.0	85.5	68.4	57.0
	5.0	1.28	480	320	240	192	160	137	120	107	96.0	76.8	64.0
	6.0	1.40	525	350	263	210	175	150	131	117	105	84.0	70.0
	7.0	1.51	566	378	283	227	189	162	142	126	113	90.6	75.5

**SECTION 7 –  
SPRAY SYSTEMS**



03	1.0	0.68	255	170	128	102	85	72.9	63.8	56.7	51.0	40.8	34.0
	1.5	0.83	311	208	156	125	104	88.9	77.8	69.2	62.3	49.8	41.5
	2.0	0.96	360	240	180	144	120	103	90.0	80.0	72.0	57.6	48.0
	3.0	1.18	443	295	221	177	148	126	111	98.3	88.5	70.8	59.0
	4.0	1.36	510	340	255	204	170	146	128	113	102	81.6	68.0
	5.0	1.52	570	380	285	228	190	163	143	127	114	91.2	76.0
	6.0	1.67	626	418	313	251	209	179	157	139	125	100	83.5
	7.0	1.80	675	450	338	270	225	193	169	150	135	108	90.0
04	1.0	0.91	341	228	171	137	114	97.5	85.3	75.8	68.3	54.6	45.5
	1.5	1.12	420	280	210	168	140	120	105	93.3	84.0	67.2	56.0
	2.0	1.29	484	323	242	194	161	138	121	108	96.8	77.4	64.5
	3.0	1.58	593	395	296	237	198	169	148	132	119	94.8	79.0
	4.0	1.82	683	455	341	273	228	195	171	152	137	109	91.0
	5.0	2.04	765	510	383	306	255	219	191	170	153	122	102
	6.0	2.23	836	558	418	335	279	239	209	186	167	134	112
	7.0	2.41	904	603	452	362	301	258	226	201	181	145	121
05	1.0	1.14	428	285	214	171	143	122	107	95	85.5	68.4	57.0
	1.5	1.39	521	348	261	209	174	149	130	116	104	83.4	69.5
	2.0	1.61	604	403	302	242	201	173	151	134	121	96.6	80.5
	3.0	1.97	739	493	369	296	246	211	185	164	148	118	98.5
	4.0	2.27	851	568	426	341	284	243	213	189	170	136	114
	5.0	2.54	953	635	476	381	318	272	238	212	191	152	127
	6.0	2.79	1046	698	523	419	349	299	262	233	209	167	140
	7.0	3.01	1129	753	564	452	376	323	282	251	226	181	151
06	1.0	1.37	514	343	257	206	171	147	128	114	103	82.2	68.5
	1.5	1.68	630	420	315	252	210	180	158	140	126	101	84.0
	2.0	1.94	728	485	364	291	243	208	182	162	146	116	97.0
	3.0	2.37	889	593	444	356	296	254	222	198	178	142	119
	4.0	2.74	1028	685	514	411	343	294	257	228	206	164	137
	5.0	3.06	1148	765	574	459	383	328	287	255	230	184	153
	6.0	3.35	1256	838	628	503	419	359	314	279	251	201	168
	7.0	3.62	1358	905	679	543	453	388	339	302	272	217	181
08	1.0	1.82	683	455	341	273	228	195	171	152	137	109	91
	1.5	2.23	836	558	418	335	279	239	209	186	167	134	112
	2.0	2.58	968	645	484	387	323	276	242	215	194	155	129
	3.0	3.16	1185	790	593	474	395	339	296	263	237	190	158
	4.0	3.65	1369	913	684	548	456	391	342	304	274	219	183
	5.0	4.08	1530	1020	765	612	510	437	383	340	306	245	204
	6.0	4.47	1676	1118	838	671	559	479	419	373	335	268	224
	7.0	4.83	1811	1208	906	725	604	518	453	403	362	290	242
10	1.0	2.28	855	570	428	342	285	244	214	190	171	137	114
	1.5	2.79	1046	698	523	419	349	299	262	233	209	167	140
	2.0	3.23	1211	808	606	485	404	346	303	269	242	194	162
	3.0	3.95	1481	988	741	593	494	423	370	329	296	237	198
	4.0	4.56	1710	1140	855	684	570	489	428	380	342	274	228
	5.0	5.10	1913	1275	956	765	638	546	478	425	383	306	255
	6.0	5.59	2096	1398	1048	839	699	599	524	466	419	335	280
	7.0	6.03	2261	1508	1131	905	754	646	565	503	452	362	302

15	1.0	3.42	1283	855	641	513	428	366	321	285	257	205	171
	1.5	4.19	1571	1048	786	629	524	449	393	349	314	251	210
	2.0	4.83	1811	1208	906	725	604	518	453	403	362	290	242
	3.0	5.92	2220	1480	1110	888	740	634	555	493	444	355	296
	4.0	6.84	2565	1710	1283	1026	855	733	641	570	513	410	342
	5.0	7.64	2865	1910	1433	1146	955	819	716	637	573	458	382
	6.0	8.37	3139	2093	1569	1256	1046	897	785	698	628	502	419
	7.0	9.04	3390	2260	1695	1356	1130	969	848	753	678	542	452
20	1.0	4.56	1710	1140	855	684	570	489	428	380	342	274	228
	1.5	5.58	2093	1395	1046	837	698	598	523	465	419	335	279
	2.0	6.44	2415	1610	1208	966	805	690	604	537	483	386	322
	3.0	7.89	2959	1973	1479	1184	986	845	740	658	592	473	395
	4.0	9.11	3416	2278	1708	1367	1139	976	854	759	683	547	456
	5.0	10.19	3821	2548	1911	1529	1274	1092	955	849	764	611	510
	6.0	11.16	4185	2790	2093	1674	1395	1196	1046	930	837	670	558
	7.0	12.05	4519	3013	2259	1808	1506	1291	1130	1004	904	723	603

*NOTE: The previous tabulations are based on 15-inch/40 cm nozzle spacing. Visit [www.teejet.com](http://www.teejet.com) for tabulations if choosing spacing other than 15"/40 cm.*

## Verifying Calibration

**⚠ WARNING**

Do not add chemicals until calibration is complete. Contact with chemicals may cause serious injury or death.

To test your system, fill the solution tanks with clean water. **Do not add chemicals until calibration is complete.**

1. Engage the parking brake.
2. Start the engine.
3. Throttle the engine to operating speed.
4. Turn the spray system console ON.
5. Change the drive state of the machine to Field Mode on the Machine Display - Home Page.
6. Press the Tank Valve Selector Switches - Left and Right (located on the side console) in the UP (Main Tank) position.
7. Press the Master Spray Switch (located on the Hydrostatic Drive Control Handle) in the ON position.
8. Press all Boom Solution Valve Switches (located on the side console) in the ON position.
9. Press the Manual ("MAN") Rate Control Switch (located on the side console).

10. Press the Pump Speed/Rate Switches (located on the side console) in the "+" position to increase flow.
11. Ensure there are no leaks and that all nozzles are spraying a desirable pattern.
12. Continue spraying in the stationary position for at least 10 minutes for proper warm-up of the sprayer and system.

Once the sprayer has had an adequate warm-up period, you will need to perform a "self test" to simulate speed (although the machine will remain stationary).

*NOTE: The following "self-test" steps require measuring flow at given pressure.*

- Collect one nozzle's spray for one (1) minute in an adequately sized and marked container.
- Verify that the collection equals or is close to the GPM (l/min) for the nozzle, pressure, speed, GPA (l/ha), and spacing that you are using.

Also to ensure accuracy, you will need to verify the flow meter. To do so:

- Collect one nozzle's spray for one (1) minute and multiply it by the number of nozzles on the boom. This should equal the amount measured through the flow meter.

## **Calculating Spray Width**

The spray section widths will need to be entered into the spray system console during initial set-up. No matter what the length of the boom is or how many spray sections it has, the formula for calculating section widths are the same.

$$\text{Number of Nozzles x Nozzle Spacing} \\ = \text{Spray Section Width}$$

### **Further Information**

Refer to the spray system console manufacturer's operation manual for complete operating and calibrating instructions, troubleshooting tips, and safety precautions.



## SECTION 8 – MAINTENANCE AND STORAGE



Hagie Manufacturing Company LLC  
P.O. Box 273 • Clarion, IA 50525-0273  
Hagiehelp.com

LUBRICATION RECOMMENDATIONS			
COMPONENT	GENERAL SPECIFICATION	RECOMMENDED LUBRICANT	RECOMMENDED SERVICE INTERVAL
Engine Oil	API CJ-4 15W-40	JD Plus-50 II 15W40	Change at 500 hours to JD Plus-50 II
Engine Coolant	ASTM D6210 Nitrite free	John Deere Cool Gard II EG 50/50 mix	2000 Hours or 2 Years
Hydraulic Oil	ISO 11158, Type HM/HV, VG 46	John Deere Hy-Gard™	Oil Analysis Guidance or Change at 1000 Hours
Planetary/Hub Drives	Synthetic API GL-5/MT-1	Mobil Delvac Synthetic Gear Oil 75W-90	Oil Analysis Guidance or 250 hours/Yearly
Greased Points	NLGI, EP, ISO 220	SD Polyurea	Daily

PLEASE CONSULT MANUAL FOR FURTHER DETAILS

650780

### NOTICE

Remove all chemical residue from the work area before performing service/maintenance.

### NOTICE

Pump repair and replacement should be performed by qualified service personnel only. Replace with properly rated components. Refer to your parts manual for further information.

### NOTICE

Refer to your parts manual when replacing hydraulic hoses to ensure you have the correct pressure rated hose.

## SERVICE - FLUIDS

### Hydraulic Oil

### NOTICE

Ensure area is clean before changing hydraulic oil and filters to avoid contamination, such as dirt and debris. Failure to comply may result in severe hydraulic system damage.

### NOTICE

Ensure engine is off before filling hydraulic oil reservoir.

Check the Hydraulic Oil Reservoir Sight Gauge level daily. Add just enough fluid to maintain oil level at mid-sight gauge.

*NOTE: Hydraulic oil expands when heated. Always check oil level when it is cool.*

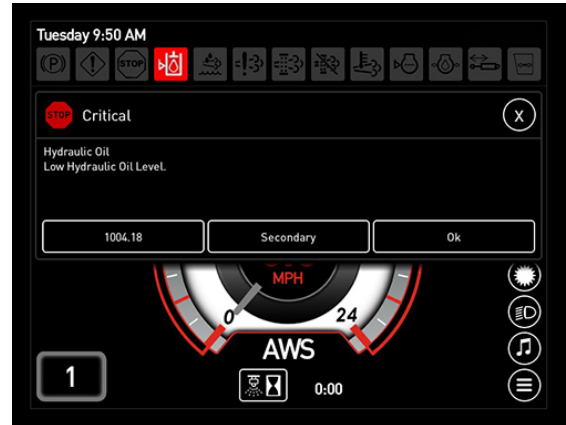
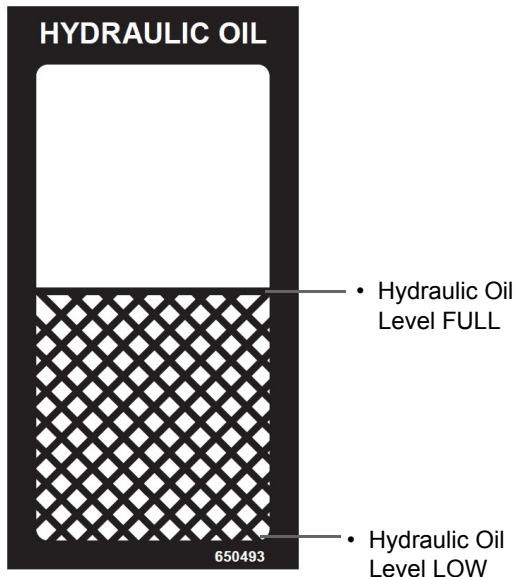

Low Hydraulic Oil Level Warning Message  
(Located on the Machine Display)

*NOTE: Replace hydraulic oil every 1,000 hours of operation.*

### Filling the Hydraulic Oil Reservoir



Hydraulic Oil Reservoir Sight Gauge  
(Located near the rear left-hand side of machine)  
-Typical View

If hydraulic oil level is too low for safe operation, a warning message will appear on the Machine Display to alert you of low hydraulic oil level. Press OK to acknowledge, shut down the engine immediately, and refill reservoir to proper level to avoid damage to the hydraulic systems.

## NOTICE

Ensure the transom is fully raised, booms folded and cradled, wheel tread fully retracted, and all wheels straight before filling the hydraulic oil reservoir. Failure to comply may result in over or under filling of the hydraulic oil reservoir and inaccurate sight gauge reading.

### Capacity

- 25 gallons (94.5L)

### Type

- John Deere Hy-Gard™ Hydraulic Oil

Hydraulic oil can be added two different ways:

1. Through the hydraulic oil fill port (located on the side of the hydraulic return filter housing); or
2. Through the top of the hydraulic return filter housing. Remove bolts and cover to access.



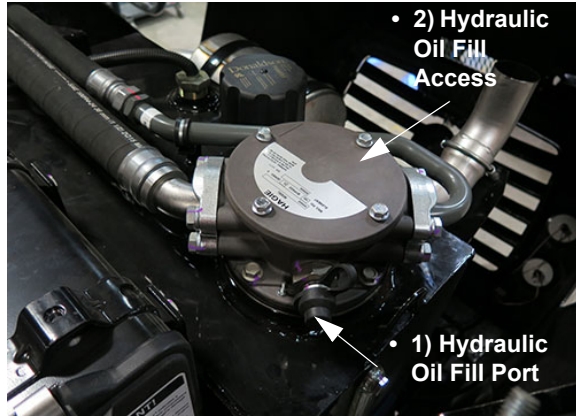

Hydraulic Oil Fill Options  
-Typical View

### Method 1 - Filling Through Hydraulic Oil Fill Port (Preferred Method)

*NOTE: A hydraulic oil pump is required to fill through the hydraulic oil fill port, as gravity will not work and there is a small pressure to be overcome.*

*NOTE: Two (2) quick coupler fittings are provided in your tool kit to provide connection between the hydraulic oil fill port and the hydraulic oil pump that you are using.*

- Remove the fill port rubber end cap.
- Attach hydraulic oil pump quick-connect fitting to the hydraulic oil fill port.
- Slowly squeeze pump handle and fill reservoir until oil level reaches mid-sight gauge.



Filling Tank Through Hydraulic Oil Fill Port  
-Typical View

- When finished filling, release pump handle and disconnect quick-connect fitting from fill port.
- Reinstall fill port rubber end cap.

### Method 2 - Filling Through Hydraulic Return Filter Housing

*NOTE: Clean dirt/debris from return filter housing cover before removing.*

- Using a 1/2" wrench, remove the four (4) bolts (located on top of the hydraulic return filter housing) and set aside.
- Remove cover and fill reservoir until oil level reaches mid-sight gauge.



Filling Tank Through Hydraulic  
Return Filter Housing  
-Typical View

- When finished filling, reinstall hydraulic return filter housing cover and bolts.

### Wheel Hub Oil

Each wheel hub should maintain a proper oil level at all times. Less than that would limit lubrication and overfilling would cause overheating and gear box damage.

#### Capacity

- 27 oz. (.8L)/each

#### Type

- Hagie Manufacturing Company recommends Mobil Delvac™ synthetic gear oil (75W-90) with EP features (complying with API GL-5/MT-1 specifications).

#### To check the oil level:

*NOTE: Check wheel hub oil level every 100 hours of operation.*

## SECTION 8 – MAINTENANCE AND STORAGE



1. Position wheel hub so the bottom (oil check/drain) face plug is positioned at 6 o'clock (C).

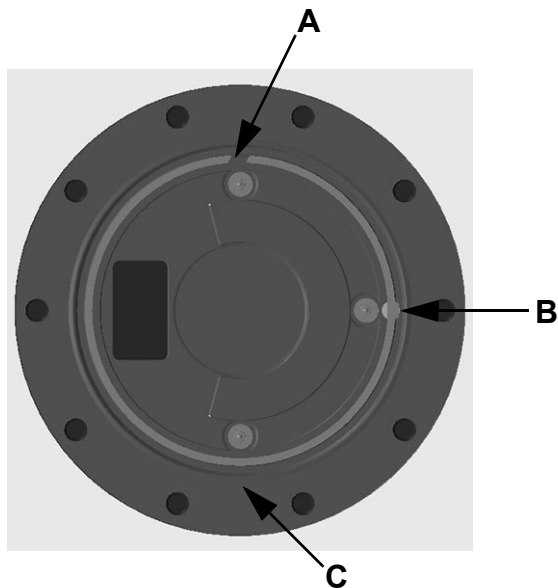
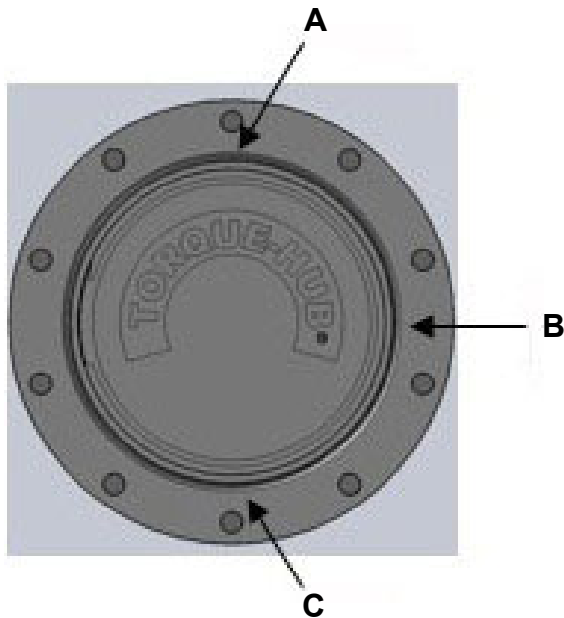

2. Using a 1/4" ball end Allen wrench, remove the 3 o'clock plug (B). If no oil comes out, proceed to Step 3.  
*NOTE: If oil is present, wheel hub oil level fill is satisfactory.*
3. If oil is needed, remove the top SAE #6 o-ring plug (A) (**1/4" ball end Allen wrench required to obtain clearance of wheel hub stud**) and fill until oil

begins to come out of the 3 o'clock plug (B).



-Typical View

4. Reinstall plugs and torque to 35 ft.-lbs.

### To change the oil:

*NOTE: Wheel hub oil should be changed after the first 50 hours of operation. After that, it should be changed every 250 hours of operation or yearly, whichever occurs first.*

1. Position wheel hub so one of the radial face plugs is positioned at 6 o'clock (C) and the other radial face plug is positioned at either the 3 or 9 o'clock positions.
2. Using a 1/4" ball end Allen wrench, remove plugs to drain oil.

*NOTE: You may only need to break the 3 or 9 o'clock plugs to allow air entrapment to escape.*

3. Once all of the oil is drained, reinstall the bottom plug (C) using a 1/4" ball end Allen wrench.
4. Rotate wheel hub to the "fill" position - one radial face plug at 12 o'clock (A), and a second plug positioned at either the 3 or 9 o'clock positions.
5. Refill wheel hub with oil until satisfactory level is met.
6. Reinstall all radial face plugs and torque to 35 ft.-lbs.

**General Maintenance****NOTICE**

Failure to rotate the wheel hub and disperse oil may cause rusting and internal wheel hub damage.

If your machine is going to sit unused for an extended period of time, occasionally rotate the wheel hubs by driving the machine forward and backward - at least half of a tire rotation to adequately coat all internal wheel hub parts. This will prevent rusting if moisture inadvertently entered the wheel hub during an oil change.

**Engine Oil****NOTICE**

Never operate the engine with oil level below the “L” (low) mark or above the “H” (high) mark on the engine oil dipstick.

**NOTICE**

The engine must be level when checking oil level to ensure accuracy.

The Engine Oil Dipstick is located on the left-hand side of the engine (through service access opening). Wait at least five (5) minutes after shutting the engine off to check the oil level.

*NOTE: Check the engine oil level daily.*

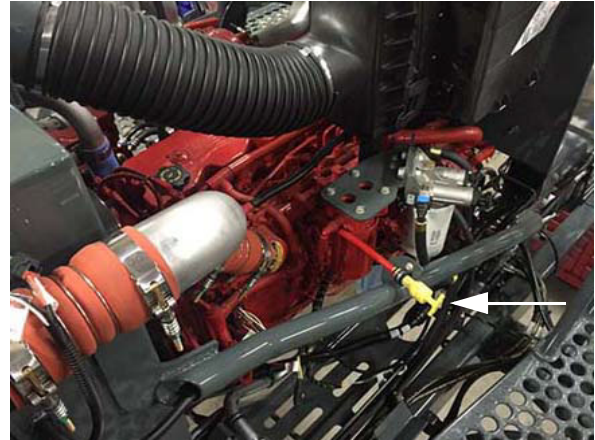

Engine Oil Dipstick  
(Located on left-hand side of engine  
through service access opening)  
-Typical View

*\* Location may vary, depending on engine option*

**Capacity**

- Engine Oil Dipstick (low to high mark capacity) = 2 quarts (1.9L)
- Engine Oil Pan Capacity (including filter and cooler) = 17.6 quarts (16.7L)

**Type**

- John Deere Plus-50™ II Premium Engine Oil

*NOTE: Change the engine oil every 500 hours of operation or yearly, whichever occurs first.*



Engine Oil Fill  
(Located near top of engine -  
open hood to access)  
-Typical View

*\* Location may vary, depending on engine option*

**Diesel Exhaust Fluid (DEF)  
(Final Tier 4 Engines)**

**⚠ WARNING**

Read the DEF manufacturer’s label and comply with safety precautions to avoid injury or damage.

**NOTICE**

Never operate the engine with low DEF level. If DEF reaches a level that is too low for safe operation, the engine will begin to derate.

**NOTICE**

Ensure engine is off before filling the DEF tank.

Check the DEF Gauge (located on the cab A-post or on the Machine Display “Engine Diagnostics” screen) daily. Add just enough DEF to keep the DEF tank full.

DEF Indicator Lamp Status
<ul style="list-style-type: none"> <li>• When DEF level reaches 10% (indicated on the DEF Gauge), DEF Indicator Lamp will illuminate.</li> </ul>
<ul style="list-style-type: none"> <li>• When DEF level drops to 5%, DEF Indicator Lamp will flash.</li> </ul>
<ul style="list-style-type: none"> <li>• When DEF level drops to 2.5%, initial engine derate begins.</li> </ul>
<ul style="list-style-type: none"> <li>• When DEF level drops to 0%, secondary engine derate begins.</li> </ul>

*NOTE: Depending on the selected final inducement option, 30 minutes after the DEF Gauge reads 0%, the engine will either be locked at idle or will shut down. Refer to the engine manufacturer’s service manual for information on how to recover from a low DEF level condition.*



DEF Gauge  
(Located on cab A-post)  
-Typical View

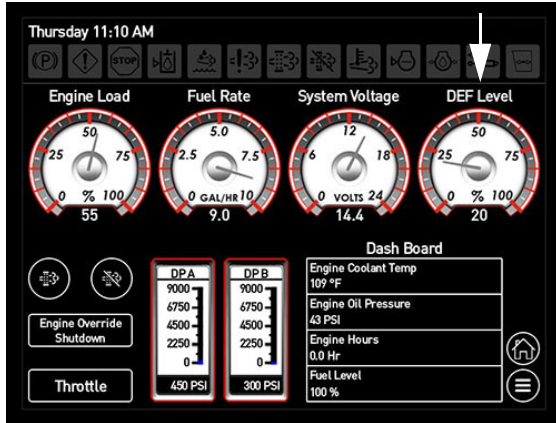

**DEF Gauge**  
(Located on the Machine Display -  
Engine Diagnostics Screen)  
-Typical View

### Capacity

- DEF Tank Capacity = 5 Gallons (18.9L)

### Type

- Use only DEF which meet ISO 2224101 standards.

*NOTE: John Deere Diesel Exhaust Fluid recommended.*

*NOTE: Refill tank with DEF every other fuel fill to maintain adequate fluid level.*

### Filling the DEF Tank

Refer to “Engine Aftertreatment - Final Tier 4” provided in the *Engine and Drive Systems Section* elsewhere in this manual for further information.

### DEF Storage

DEF has a limited shelf life, both in the machine’s DEF tank and in storage containers. The following conditions are ideal for maintaining DEF quality and shelf life during prolonged transportation and storage:

- Store DEF between 23° F (-5° C) and 77° F (25° C).
- Store DEF in sealed containers to avoid contamination.
- Avoid direct sunlight.

By following these conditions, DEF has a minimum expected shelf life of approximately 18 months.

*NOTE: When storing DEF in higher temperatures for an extended period of time, the shelf life will be reduced by approximately 6 months for every 9° F (5° C) above the highest storage temperature as previously listed.*

Long-term DEF storage in a machine (in excess of 6 months) is not recommended. If long-term storage is necessary, periodic testing of the DEF is recommended to ensure adequate concentration. Having the correct concentration of DEF is critical in engine and aftertreatment system performance.

*NOTE: To help prevent DEF deterioration when stored in the DEF tank, locate and plug the tank venting to seal tank exposure against environmental elements.*

### Checking DEF Concentration

DEF concentration should be checked when the machine has been stored for an extended period of time or if it is suspected that water has been added to the DEF tank.

- Use a refractometer to check DEF concentration.

*NOTE: Refer to the engine manufacturer’s operation manual for further information on checking DEF concentration.*

- If the DEF concentration is found to be inadequate (outside of recommended specification):

1. Drain the DEF tank.
2. Flush tank with distilled water.
3. Refill tank with new DEF.
4. Recheck DEF concentration.

### Freezing

## ⚠ CAUTION

DO NOT add any chemicals/additives to the DEF in an effort to prevent freezing. If chemicals/additives are added to the DEF, the Aftertreatment System may become damaged.

## SECTION 8 – MAINTENANCE AND STORAGE



DEF will freeze around 12° F (-11° C). The DEF system on the machine is designed to accommodate this and does not require any operator intervention.

### DEF Disposal

Check with local authority regulations on proper DEF disposal requirements.

### Cooling System

#### NOTICE

Do not use coolants that contain nitrite additives.

The cooling system should be sufficiently charged with an adequate mixture of antifreeze and water, regardless of climate, to maintain broad operating temperature range. Follow the coolant manufacturer's recommendations for your climate.

*NOTE: The cooling system has been factory-filled with an ethylene glycol-based antifreeze.*

### Capacity

- Final Tier 4 Engines = 10 gal./37.5L
- Tier 3 Engines = 9.55 gal./36.2L (Export only)

### Type

- John Deere Cool -Gard™ II Engine Coolant

### Checking Coolant Level/ Concentration



Check coolant level daily. Ensure fluid level is visible within the sight gauge. Coolant level is low if fluid is not seen in the sight gauge.



Coolant Level Sight Gauge  
(Located on the rear  
right-hand side of machine)  
-Typical View

**Changing Coolant**

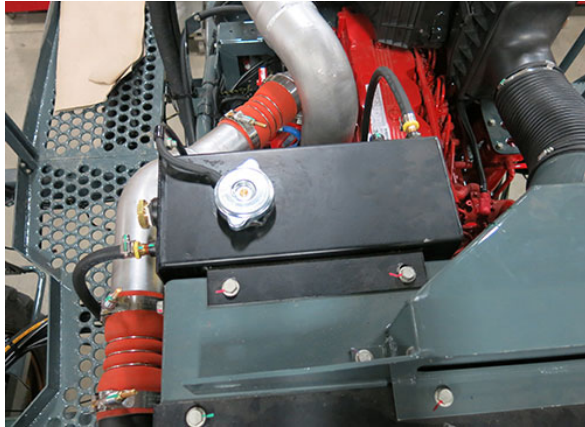

**Radiator**  
(Located near the rear of machine - open hood to access)  
-Typical View

A 50/50 ethylene glycol and water mixture is a conservative mixture, which allows protection against both overheating and freezing.

*NOTE: If a stronger antifreeze mixture is required, ensure not to exceed the engine manufacturer's guidelines for antifreeze-water mixing. Refer to "ASTM D 6210" or "ASTM D 7715" standards for further information.*

The following Ethylene Glycol Table gives a few examples of ethylene glycol antifreeze/water mixture protection values.

<b>Ethylene Glycol</b>		
40%	-23° C	-10° F
50%	-37° C	-34° F
60%	-54° C	-65° F

Coolant concentration should be checked every 500 hours of operation or at the beginning of each spray season, whichever occurs first. A refractometer should be used to check concentration.

*NOTE: "Floating Ball" type density testers are not accurate for use with a heavy duty diesel cooling system.*

**⚠ CAUTION**

**COOLING SYSTEM REQUIRES SPECIAL FILL PROCEDURE**

- Open cab heater water valve by turning the cab temperature knob to "Heat" with ignition on.
- Fill radiator to bottom of fill neck using 50/50 EG coolant mixture.
- If radiator is drained completely and refilled faster than 3 gpm (11.4 l/min), radiator may need to be topped off.
- Run engine at operating temperature for 5 minutes.
- Shut off engine.
- Wait until coolant is below 122° F before removing cap to check coolant level.
- Top off cooling system if required.
- See operator's manual for total cooling system volume.

Coolant should be changed periodically to eliminate the buildup of harmful chemicals. Drain and replace the coolant every other spray season or 1,000 hours of operation, whichever occurs first. Refill with soft water only, as hard water contains minerals, which break down the anti-corrosion properties of the antifreeze.

**Further Information**

Refer to the engine manufacturer's operation manual for further information.

**Engine Fuel**

**⚠ CAUTION**

**DIESEL FUEL CAN BE DANGEROUS**

- Turn off engine before refueling.
- Do not smoke while refueling.
- Clear off any spilled fuel after refueling.

*NOTE: Keep a fire extinguisher nearby when refueling.*

## SECTION 8 – MAINTENANCE AND STORAGE



DO NOT fill fuel tank completely. Fuel can expand and run over. Wipe up all spilled fuel and clean with detergent and water before starting the engine.

### Capacity

- Fuel Tank Capacity = 100 gal. (378.5L)

### Type

#### Final Tier 4 Engines

- Ultra-Low Sulfur Diesel (ULSD) fuel required.

#### Tier 3 Engines (Export only)

- No. 2 diesel fuel recommended. (In operating conditions less than 32° F., use a blend of No. 1 and No. 2 diesel fuel).

*NOTE: The addition of No. 1 diesel fuel may cause loss of power and/or fuel economy.*

### Filling the Fuel Tank

1. Shut the engine off.
2. Remove Fuel Fill Cap and set aside.



Fuel Fill Cap  
(Located on top of fuel-rinse module)  
-Typical View

3. Fill tank to desired level.
4. Reinstall the Fuel Fill Cap.

## Air Conditioning

### NOTICE

Charge with R-134A only. Charge to 3.50 lbs.

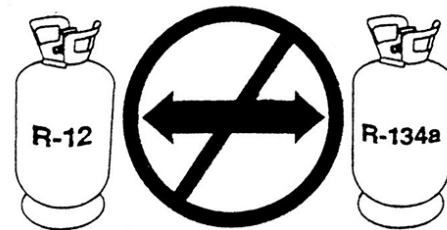

**DO NOT MIX REFRIGERANTS**

### Recharging the AC System

The cab is equipped with an R-134A Air Conditioning System. **Recharge system with R-134A refrigerant only.**

*NOTE: Confirm refrigerant before recharging the Air Conditioning System. If your system is mistakenly recharged with R-12 refrigerant, machine damage (such as compressor seizure) may result. If you do not have the proper equipment, it is recommended that you allow an authorized service technician service your Air Conditioning System.*



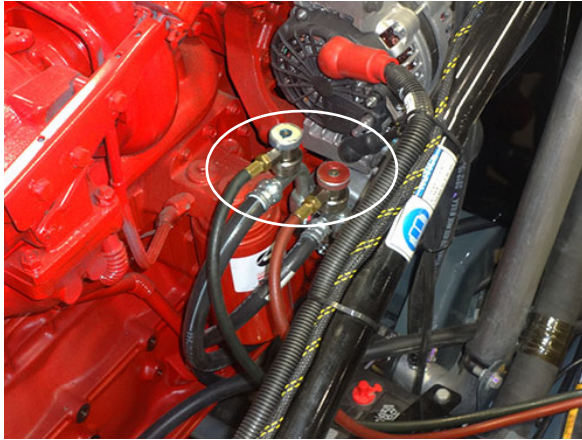

**A/C Charge Ports**  
(Located on right-hand side of engine)  
-Typical View

### Windshield Washer Fluid

The Windshield Washer Fluid Reservoir is located within the fuel-rinse module (FRM). The reservoir fill cap is conveniently located on top of the right-hand FRM.

Check fluid level before each use and fill with non-freezing automotive windshield washer fluid as required.



**Windshield Washer Fluid Reservoir Fill**  
(Located on top of the right-hand FRM)  
-Typical View

## SERVICE - FILTERS

### Engine Air Intake

The Engine Air Intake Filter is located along the platform on the left-hand side of machine (open hood to access).



**Engine Air Intake Filter**  
(Located along platform on left-hand side of machine - open hood to access)  
-Typical View

## NOTICE

Do not tap filter to remove dust. A crushed filter caused by tapping may result in engine damage. Remove and replace filter as recommended.

### Removal

The Engine Air Intake Filter should only be removed if replacement is required.

- Loosen the air pre-cleaner and remove end cap.
- Remove filter. Use care when removing the filter to ensure dust from the filter does not enter the air intake passage.

*NOTE: The secondary filter does not need to be replaced if the primary filter is intact.*

## Replacement

Your machine is equipped with a Filter Minder® to notify you of filter element efficiency.

## Cleaning

It is not recommended to clean the Engine Air Intake Filter element. However, a clean damp cloth should be used to wipe away dust and debris from the air cleaner housing.

## Filter Minder

The Filter Minder is an air restriction monitoring system that progressively and constantly indicates how much air filter capacity remains to aid in achieving best preventative maintenance practices by ensuring air filter replacement only occurs when necessary.

*NOTE: An air filter service interval message will appear on the Machine Display notifying you that the engine air filter is restricted and that filter replacement is recommended.*

## Radiator Screen

<b>NOTICE</b>
Failure to keep cooling systems clean can cause overheating and damage to the engine and hydrostatic systems.

To maintain adequate airflow through the engine cooling system, the Radiator Screen (located ahead of rear hood) must be inspected daily and cleaned as necessary.

## Cleaning the Radiator Screen (Preferred Method)

- Ensure the Hydrostatic Drive Control Handle is in the NEUTRAL position and parking brake is engaged.
- Start the engine.
- Press and hold the Throttle Switch (located near the Hydrostatic Drive Control Handle) in the UP position to throttle engine to full RPM.

- Press the Fan Reverse Button (located on the Machine Display Main Menu Page) to navigate to the “Engine Fan Control” screen.
- On the “Engine Fan Control” screen, press the Reverse Button to activate the reversible fan.
- While the fan is in reverse mode, use a whisk broom brush (or equivalent) to dislodge large debris and dirt from the Radiator Screen.
- **When finished cleaning the Radiator Screen**, press and hold the Throttle Switch in the DOWN position to decrease engine RPM.

## Cleaning the Radiator Screen (Screen Removal)

Use compressed air to dislodge large debris and dirt. Water from a pressurized hose may also be used or if necessary, the screen may be soaked with soapy water and scrubbed gently with a brush.

*NOTE: When cleaning the cooling fins of the radiator, oil cleaner, or A/C condenser with compressed air or water, be careful not to damage the cooling fins, which may impair cooling capabilities.*

## To Remove the Radiator Screen

- Remove the two (2) Engine Scoop Spring Clips (located on the top left and right-hand side of inside scoop) and set aside.

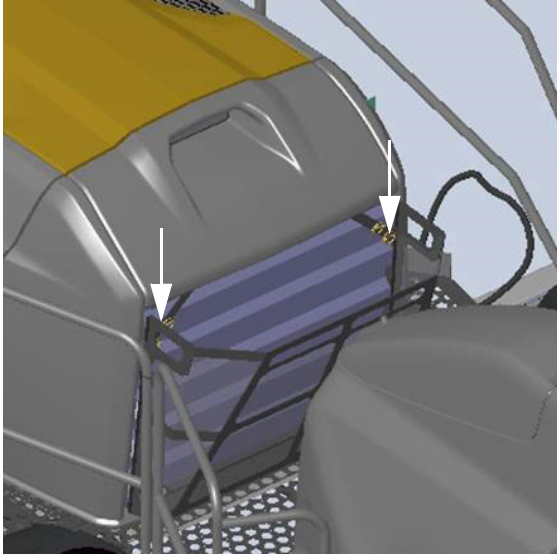

Engine Scoop Spring Clips  
(Located on the top left and  
right-hand side of inside scoop)  
-Typical View

- Remove Engine Scoop from mounts and set aside.
- Remove the two (2) Radiator Screen Spring Clips (located on the top left and right-hand side of screen) and set aside.

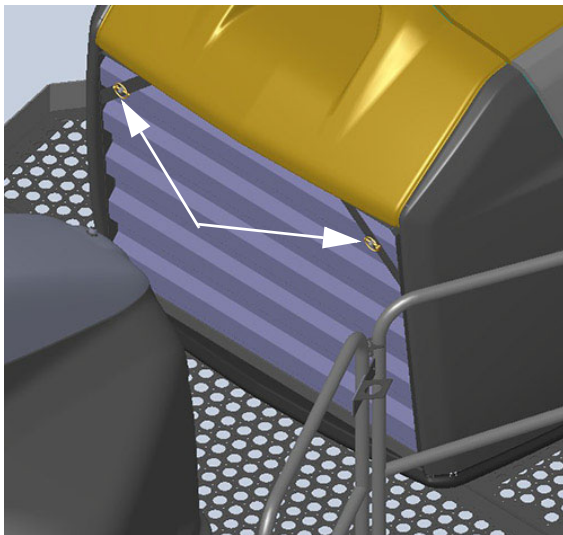

Radiator Screen Spring Clips (2)  
(Located on the top left and  
right-hand side of screen)  
-Typical View

- Extend the top of Radiator Screen outward and lift the bottom of screen out of lower pin cradles.

### To Reinstall the Radiator Screen

- At a slight angle, install the lower screen pins into the pin cradles (located near the bottom of the cooling pack), as shown in the following illustration.

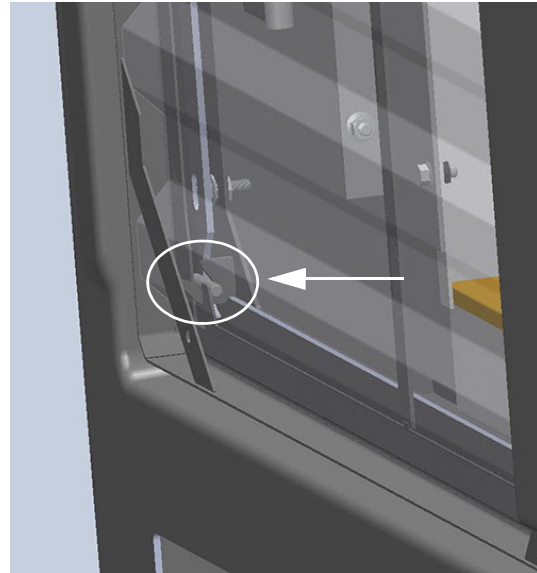

-Typical View

- Rotate screen inward until the mounting pins protrude through the screen.
- Reinstall the two (2) Radiator Screen Spring Clips.
- Reinstall Engine Scoop and Engine Scoop Spring Clips.

### Engine Oil Filter

The Engine Oil Filter (located on right-hand side of engine through access opening) should be replaced every 500 hours of operation or whenever the oil is changed, whichever occurs first.

Refer to the engine manufacturer's operation manual for further information.

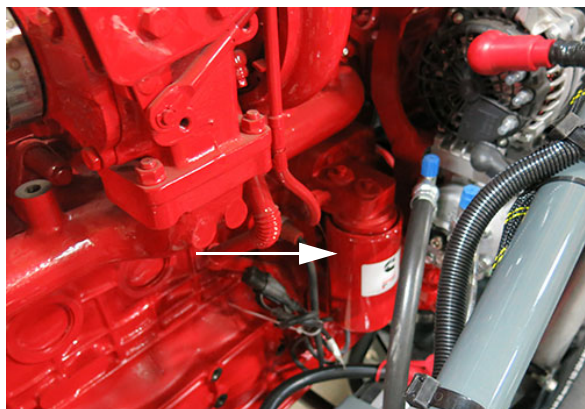

**Engine Oil Filter**  
(Located on right-hand side of engine through access opening)  
-Typical View

## Fuel Filters

### Primary Fuel Filter (Water Separator)

The Primary Fuel Filter (located on left-hand side of engine through access opening) should be drained of water and other deposits daily. Replace the filter every 500 hours of operation or yearly, whichever occurs first.

### Secondary Fuel Filter

The Secondary Fuel Filter (located on left-hand side of engine through access opening) should be replaced every 500 hours of operation or yearly, whichever occurs first.

Refer to the engine manufacturer's operation manual for further information.

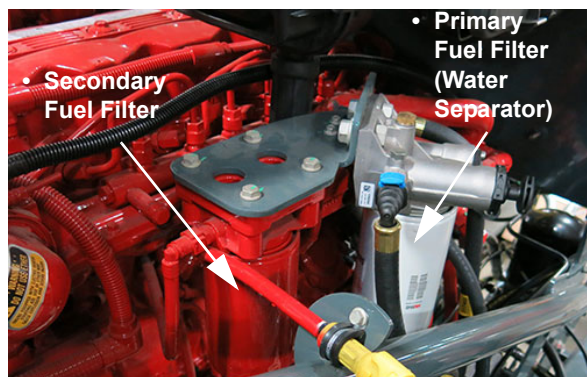

**Primary and Secondary Fuel Filters**  
(Located on left-hand side of engine through access opening)  
-Typical View

*NOTE: Cummins® recommends specific high performance fuel filters, which will aid in achieving optimum engine performance and efficiency. Refer to the engine manufacturer's operation manual for further information and specifications.*

### Diesel Exhaust Fluid (DEF) Supply Module Filter (Final Tier 4 Engines)

The DEF Supply Module Filter (located beneath rear of machine) should be replaced every 4,500 hours of operation or every three (3) years, whichever occurs first.

Refer to the engine manufacturer's operation manual for further information.

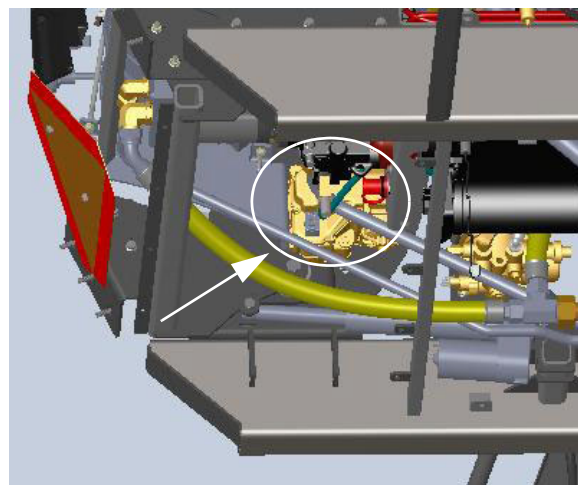

**DEF Supply Module Filter**  
(Located beneath rear of machine)  
-Typical View

*\* Rear underside of machine shown*

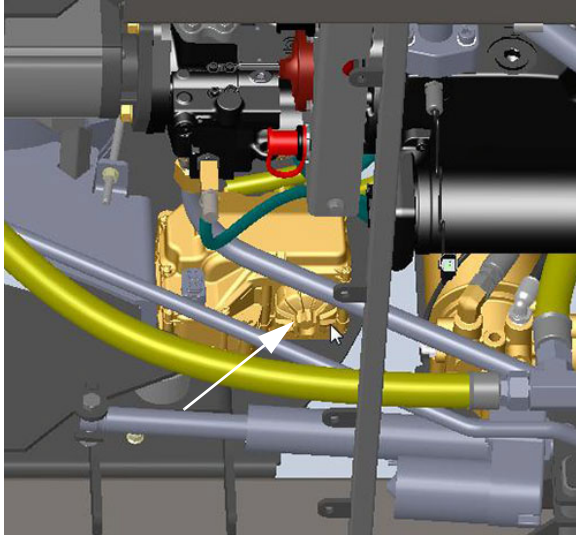

DEF Supply Module Filter  
(Close up view)  
-Typical View

## Hydraulic Filters

*(Refer to your Parts Manual for specific location and replacement part numbers)*

Remove and replace hydraulic filters every 500 hours of operation or yearly, whichever occurs first.

- Return Filter
- Pressure Filter
- Charge Pump Filter
- Tank Breather Cap

### Replacing Hydraulic Filters

#### Return Filter

*NOTE: Replace Return Filter when the filter indicator indicates that replacement is needed, becomes tripped, or after 500 hours of operation, whichever occurs first.*

1. Remove the four (4) bolts on top of the Return Filter Housing (located on top of hydraulic oil reservoir - open hood to access) and set aside.



Return Filter Housing  
(Located on top of hydraulic oil reservoir - open hood to access)  
-Typical View

2. Remove Return Filter Housing cover and set aside.
3. Remove and discard used Return Filter.



Return Filter  
(Located inside filter housing)  
-Typical View

4. Install new Return Filter.
5. Reinstall filter housing cover and bolts.

#### Pressure Filter

1. Using a 15/16" wrench on the Pressure Filter Housing end bolt, turn "counter-clockwise" and remove filter housing.

## SECTION 8 – MAINTENANCE AND STORAGE

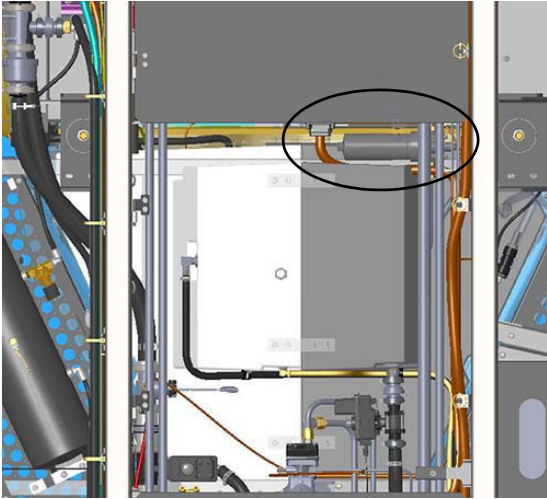

Pressure Filter  
(Located beneath front  
left-hand side of machine)  
-Typical View

2. Remove and discard used Pressure Filter.
3. Install new Pressure Filter.
4. Reinstall Pressure Filter Housing and metal shield.

### Charge Pump Filter

1. Ensure the engine is shut OFF.
2. Hold the Charge Pump Filter (located beneath rear of machine) in place and remove filter from housing using a 24mm wrench.

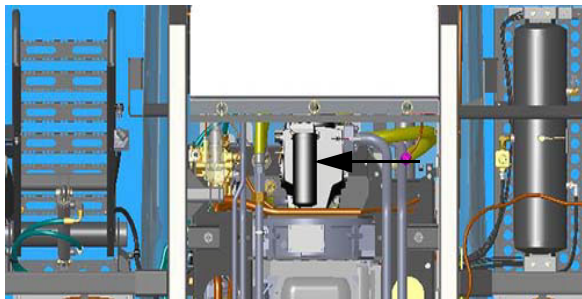

Charge Pump Filter  
(Located beneath rear of machine)  
-Typical View

3. Remove and discard used Charge Pump Filter.

*NOTE: Inspect the plug and seal surfaces in the filter bracket. Replace any damaged components.*

4. Lubricate the seal and o-ring with hydraulic fluid.
5. Insert plug into filter bracket.
6. Using a 24mm wrench to hold the plug in place, install new Charge Pump Filter.

*NOTE: Hand-tighten filter until it makes contact with the o-ring, then tighten half a turn further.*

7. Turn the engine ON.
8. Cycle the pump through normal machine operation and check for leaks.

### Tank Breather Cap

1. Loosen Tank Breather Cap (located on top of hydraulic oil reservoir - open to access) by turning “counter-clockwise”.



Tank Breather Cap  
(Located on top of hydraulic oil  
reservoir - open hood to access)  
-Typical View

2. Remove and discard used Tank Breather Cap.
3. Install new Tank Breather Cap and turn “clockwise” to tighten.

**Strainers**

*(Refer to your Parts Manual for specific location and replacement part numbers)*

**Solution Line Strainer**

**(50-Mesh Strainer Screen)**

⚠ CAUTION

Ensure the Solution and Agitation Valves are CLOSED before servicing the Solution Line Strainer. Failure to comply may result in chemical contact.

Maintain consistent application rates by inspecting the Solution Line Strainer (located beneath center of machine) daily for blockage. Clean the strainer screen as needed and ensure the gasket is in place before reinstalling the screen.

*NOTE: Wear appropriate PPE while removing and cleaning the strainer screen.*

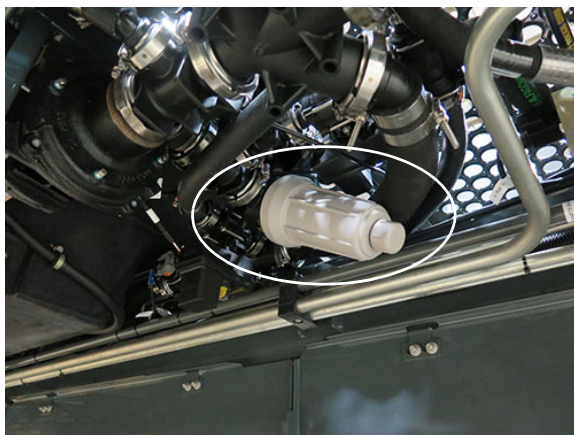

Solution Line Strainer  
(Located beneath center of machine)  
-Typical View

**Section Strainers**

**(80-Mesh Strainer Screens)**

Section Strainers are located throughout each boom section and filter impurities to aid in the avoidance of spray nozzle buildup. Remove bottom section of each strainer and clean strainer screen as needed.

*NOTE: Wear appropriate PPE while removing and cleaning the strainer screen.*

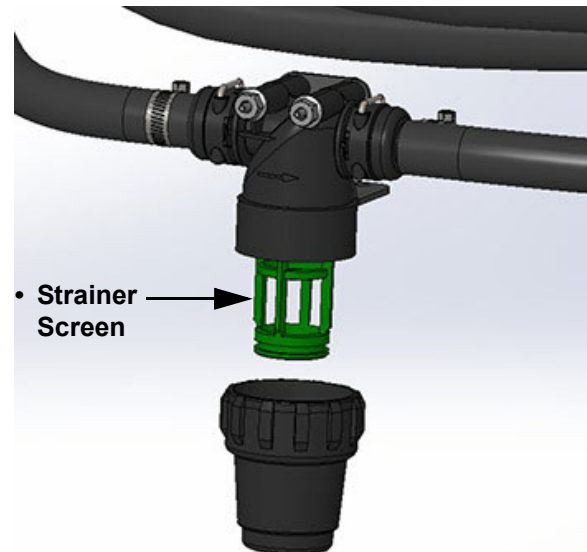

Section Strainer  
(Located throughout each boom section)  
-Typical View

**Foam Marker Strainer**

**- If Equipped  
(80-Mesh Strainer Screen)**

If your machine is equipped with the foam marker system, it will have a mesh strainer (located beneath the rinse tank on left-hand side of machine). Inspect the strainer for blockage if you are unable to obtain adequate pressure.

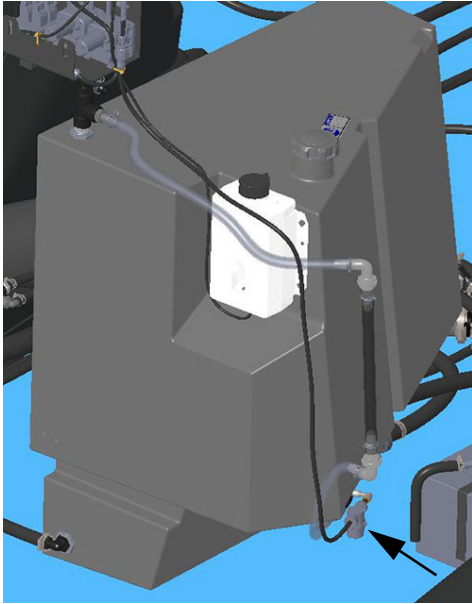

Foam Marker Strainer  
(Located beneath the rinse tank  
on left-hand side of machine)  
-Typical View

## Cab Filters

### RESPA® Cab Filter

*NOTE: Replace the RESPA Cab Filter every 1,000 of operation or when cab pressure drops below the minimum pressure threshold (when cab is sealed), whichever occurs first.*

#### Replacing the RESPA Cab Filter:

## ⚠ CAUTION

Do not clean or reuse filters. Failure to comply may create health hazards.

## NOTICE

Replace filter in a clean and covered area to reduce operator and HVAC exposure to harmful particulates.

## NOTICE

Ensure engine is turned OFF before servicing the RESPA Cab Filtration System.

## NOTICE

When cleaning your machine, care should be taken to prevent high-pressure water or air from entering the RESPA Filtration System ejection slots. When replacing the slotted filter, do not point ejection slots at a solid surface in close proximity to the slots.

*NOTE: Wear Personal Protective Equipment (PPE) when servicing the RESPA Cab Filtration System.*

1. Turn engine OFF.
2. Inspect RESPA Cab Filtration System for damage.
3. Release the four (4) Filter Latches (located on the exterior filter housing).

*NOTE: Note orientation of the ejection ports.*





Filter Latches  
-Typical View

4. Remove filter.

*NOTE: When removing filter, place thumbs on exterior filter housing hardware for additional leverage.*

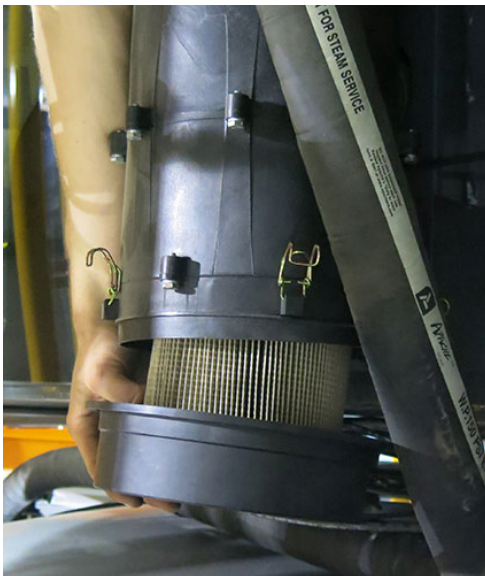

Filter Removal  
-Typical View

5. Place used filter in a sealed plastic bag and dispose.

*NOTE: Dispose of filter according to local regulations.*

6. Wipe off any loose debris around the filter housing using a clean cloth.

*NOTE: DO NOT use compressed air to clean the filter housing.*

7. Before installing the new filter, inspect the RESPA Cab Filtration System and replacement filter for proper operation.
8. Turn RESPA Filtration System ON, staying clear of the open end of the filter housing.
9. Ensure adequate airflow is blowing out of the empty filter housing.
10. Turn RESPA Filtration System OFF.
11. Install new filter.

*NOTE: Ensure new filter ejection port orientation is correct and the filter end cap is properly seated on the filter housing (with the gills pointing downward to avoid water from entering in).*

12. Re-latch the four (4) Filter Latches.  
Refer to your Parts Manual for replacement part number.

### Charcoal Filter

Remove and replace the Charcoal Filter at the first sign of chemical odor entering the cab area, or every 500 hours of operation at a minimum. Refer to your Parts Manual for replacement part number.

### Accessing the Charcoal Filter

1. Loosen the top metal Flange Clamp (located near the top of the RESPA filtration unit).



Flange Clamp - Top  
(Located near the top of  
the RESPA filtration unit)  
-Typical View

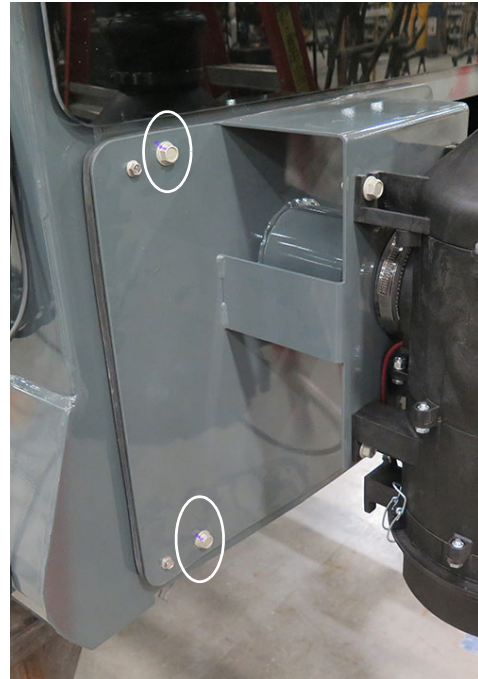

Mounting Bolts (4)  
(Two located on each side of access  
panel on the right-hand side of cab)  
-Typical View

2. Separate the RESPA filter housing from the vent tube.
3. Remove the four (4) Mounting Bolts (two located on each side of access panel on the right-hand side of cab) and set aside.
4. Carefully lower access panel/filter assembly to the ground.
5. With the access panel removed, loosen and remove the Security Screw (located along the inside of filter compartment) and set aside.

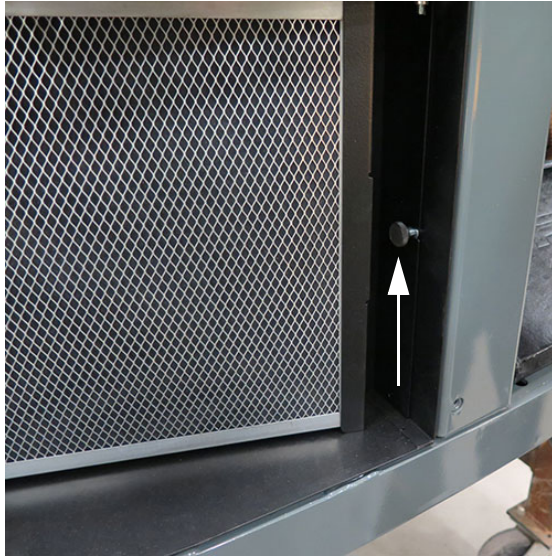

**Security Screw**  
(Located along the inside  
of filter compartment)  
-Typical View

6. Remove the Filter Bracket (located along the right-hand side of charcoal filter) and set aside.

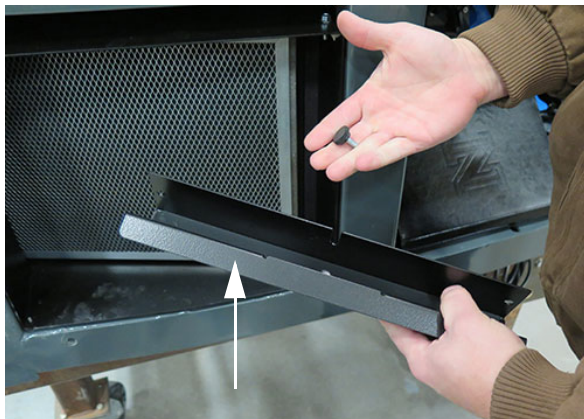

**Filter Bracket**  
(Located along the right-hand  
side of charcoal filter)  
-Typical View

7. Remove Charcoal Filter.



**Charcoal Filter**  
-Typical View

8. Replace Charcoal Filter and reverse steps to reinstall.

### Recirculation Filter

A Recirculation Filter is located along the right-hand side of compartment (accessible after the Charcoal Filter has been removed). Remove the Recirculation Filter and clean with soap and warm water (wring out gently) anytime that the Charcoal Filter is replaced.

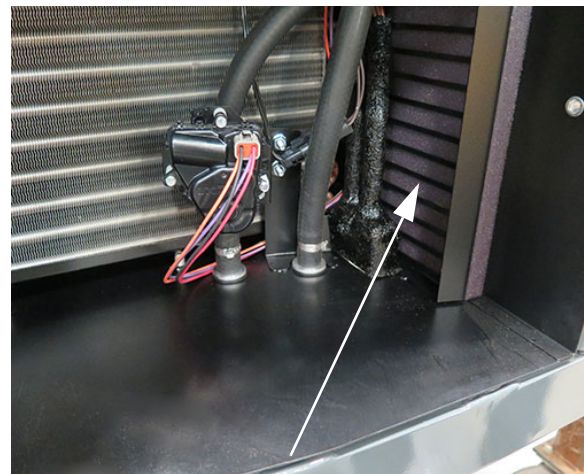

**Recirculation Filter**  
(Located along the right-hand  
side of compartment)  
-Typical View

**SERVICE - LUBRICATION**

**NOTICE**

Failure to properly lubricate pivot and friction points may result in unnecessary wear and damage.

**NOTICE**

SD Polyurea grease (complying with NLGI, EP, and ISO 220 specifications) recommended.

**Legs and Steering**

**Tie Rod Ball**

(Front Legs)

- Lubricate every 25 hours of operation, or as needed.

*NOTE: If your machine is equipped with AWS, the steering cylinders on the rear legs will also have grease zerks in the tie rod ends that require lubrication.\**



Tie Rod Ball Grease Zerk  
(Located on the front legs\*)  
-Typical View

**Tower Bearing**

(Front and Rear Legs)

- Lubricate daily, or as needed.

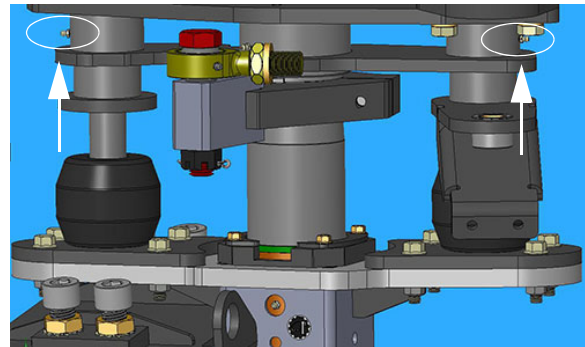

Tower Bearing Grease Zerks  
(Located on the front and rear legs)  
-Typical View

**Leg Bearings**

- Lubricate daily, or as needed.

The leg assemblies on your machine are constructed with upper and lower nylon bearings for suspension telescoping between the inner and outer leg weldments. These bearings must be lubricated to avoid bearing failure and ensure optimal ride quality. Grease zerks are located on the sides of the leg assemblies - one on the upper bearing, and two on the lower bearing.

*NOTE: If the crop is mature enough or plant population is high enough, more frequent leg bearing grease application may be required to ensure proper lubrication and optimal performance.*

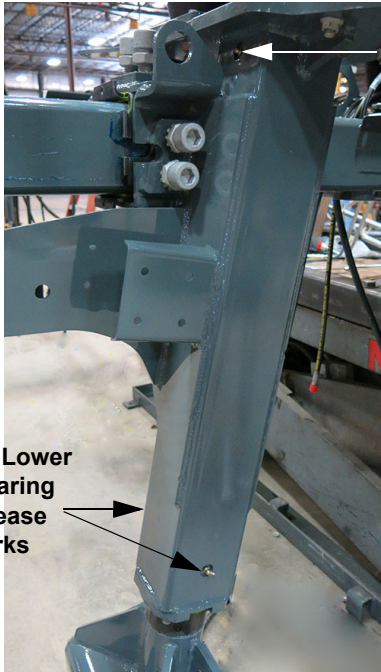

- (1) Upper Bearing Grease Zerk
- (2) Lower Bearing Grease Zerks

Leg Bearing Grease Zerks  
-Typical View



Tread Adjust Bearing Slide Path (4)  
(Located on each leg)  
-Typical View

*NOTE: During late season crop applications, the grease may possibly be wiped away due to the passing of crop leaves. More frequent grease application may be required to ensure proper lubrication and optimal performance.*

## Tread Adjust Bearing Slide Path

### NOTICE

Failure to inspect and lubricate the tread adjust bearing slide path may cause one of the legs to “hang up” while the other is still sliding during adjustment. Failure to comply may result in machine damage.

- Inspect and clean the Tread Adjust Bearing Slide Path often (all four sides on each leg). Lubricate generously as needed.

## Ladder Pivot Tube

Lubricate the grease zerk (located on the back side of the Ladder Pivot Tube) every 50 hours of operation, or as required.

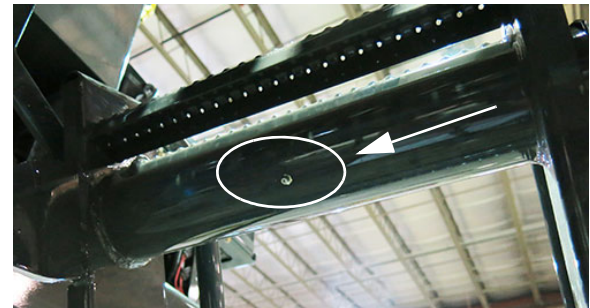

Ladder Pivot Tube  
-Typical View

## Spray Boom

### Outer Fold Joint Rod Ends

Lubricate the grease zerks on the Outer Fold Joint Rod Ends (two located on each side) every 50 hours of operation, or as needed.

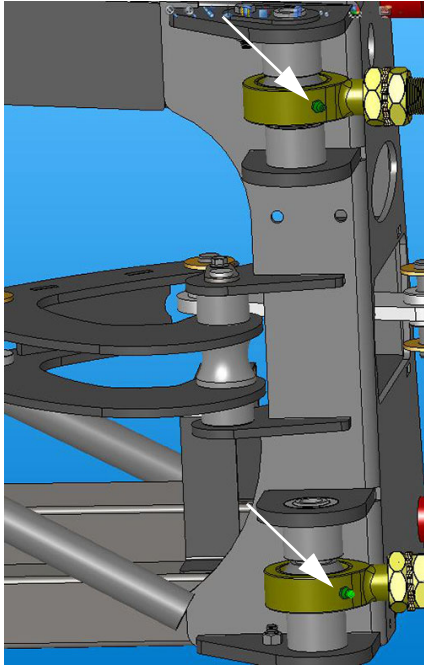

Outer Fold Joint Rod End Grease Zerks  
-Typical View

## SERVICE - ENGINE DRIVE BELT

### Removal

- Insert a 1/2" square ratchet drive into the belt tensioner. See following illustration.

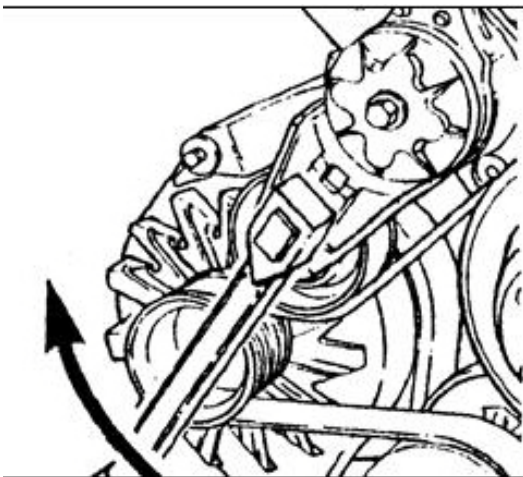

-Typical View

- Lift UP and remove Engine Drive Belt.

### Inspection

- Visually inspect the Engine Drive Belt daily.
- Check the belt for intersecting cracks. See following illustration.

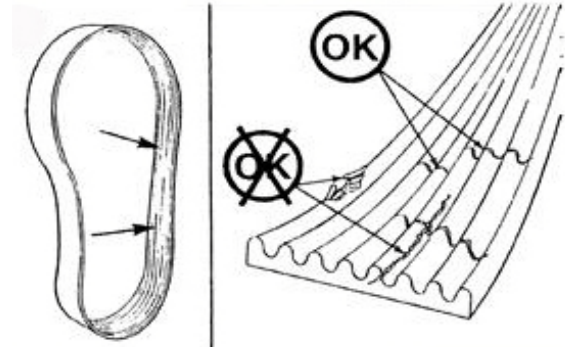

-Typical View

*NOTE: Transverse cracks (across the belt width) are acceptable. Longitudinal cracks (direction of the belt length) that intersect with transverse cracks are not acceptable.*

- Replace the Engine Drive Belt if it is frayed or has material missing.

## SERVICE - BOLT TORQUE

### NOTICE

Check lug nut torque immediately after receiving the machine and every 50 hours of operation thereafter.

### Lug Nuts

*NOTE: If you do not have the proper equipment to mount a tire, contact a local qualified tire service center.*

The tire should be mounted on the rim (as shown in the following illustration) for optimal traction and tread cleaning action.



**To Install Wheel/Tire Assembly onto the Wheel Hub**

1. Ensure threads are thoroughly cleaned of rust and dirt.

*NOTE: Ensure threads are properly lubricated.*

2. Align the wheel bolt holes with the wheel hub studs.
3. Mount wheel on the hub.
4. Install 3/4" Spacer Ring around the wheel hub.

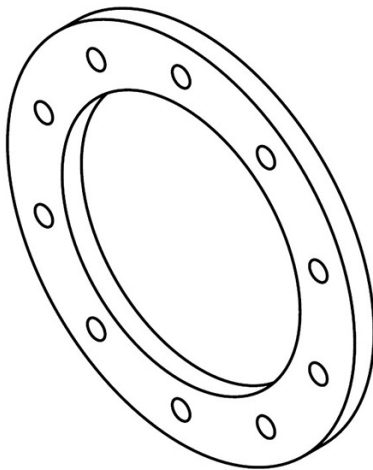

3/4" Spacer Ring  
-Typical View

5. Install lug nuts to the wheel bolts.



Lug Nut Installation  
-Typical View

6. Start all of the lug nuts and tighten until snug.
7. Following the torque sequence (as shown the following illustration), turn each lug nut to a torque value of 120 dry ft.-lbs.

*NOTE: Use slow, even pressure on the torque wrench. Quick or jerky movements can cause inaccurate values.*



Torque Sequence

## SECTION 8 – MAINTENANCE AND STORAGE



- Repeat the same sequence to 185 ft.-lbs.

*NOTE: If the wheel turns during lug nut torquing, lower machine to the ground - just enough for the tire to touch and prevent rotation. Or, more preferably, place a suitable wedge between the tire and the ground. Lower the machine and resume operation. Recheck torque after 30 minutes of operation.*

- When torquing is complete, lubricate exposed threads with anti-seize compound.

### Tread Adjust Bearing Bolt Torque

*NOTE: With the engine turned OFF, visually inspect the Tread Adjust Bearing Bolts on both the top and side tread adjust bearing plates daily. Check the torque every 100 hours of operation.*

## NOTICE

Never operate machine with loose or missing tread plates. To visually inspect for loose tread plates, slowly rock the machine forward and backwards while observing the legs for movement. If plates become loose, the leg will rock as the machine starts to move.

- Loosen the Jam Nut on each Tread Adjust Bearing Bolt.

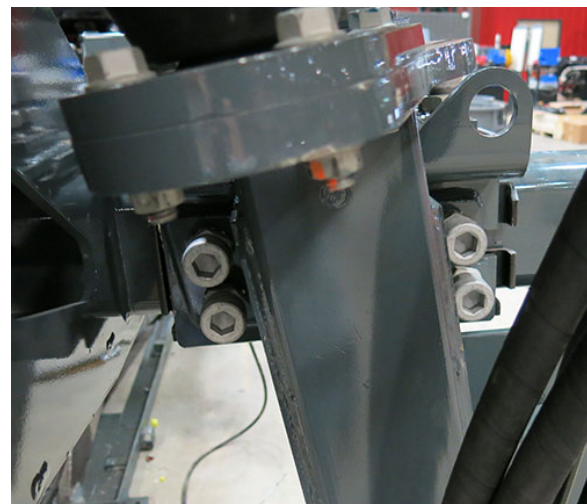
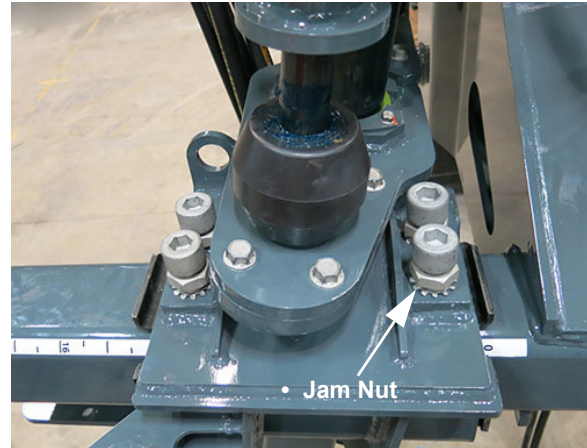

Tread Adjust Bearing Bolts - Top/Side  
(Located on each leg)  
-Typical View

- (a) Hydraulic Tread Adjust Machines** - Using an “X” pattern (as shown in the following photo), torque each Tread Adjust Bearing Bolt to 65 ft.-lbs.
  - (b) Mechanical Tread Adjust Machines** - Using an “X” pattern (as shown in the following photo), torque each Tread Adjust Bearing Bolt to 100-ft.-lbs.





“X” Pattern  
-Typical View

3. Repeat pattern 3 to 4 times until the last sequence shows no movement of the bolts to achieve desired torque.
4. Re-torque each Jam Nut to 200 ft.-lbs.

### NOTICE

Even pressure of the tread adjust bearing plate is required for proper operation.

- **Figure A** - shows correct position of the tread adjust bearing plates and bolts, as well as the outer leg.
- **Figure B** - shows the plates when there is not even torque on each of the tread adjust bearing bolts.
- **Figure C** - shows a situation in which there is not enough torque on the tread adjust bearing bolts.

*NOTE: Figures B and C will cause tread adjust to operate incorrectly, or not at all.*

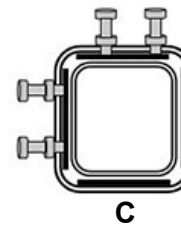
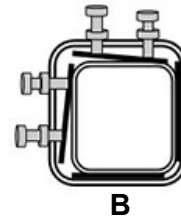
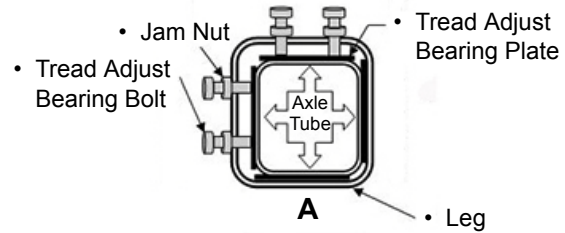

## SERVICE - TOE-IN

### Step 1 - Phase Steering Cylinders

The steering cylinders must be phased before any mechanical adjustments can be made (cylinder stroke = 8.8"/22.4 cm). When the cylinders are re-phased, each cylinder should reach mid-stroke (4.4"/11.2 cm). Once both cylinders are at 4.4"/11.2 cm, Toe-In can be set.

**To Phase the Steering Cylinders**

NOTICE

Disconnect cylinders from legs before aligning the wheels. Separating the hydraulic components (cylinders) from the mechanical components (position of wheels) is a critical step to improve the toe-in procedure. Ensure all cylinders are reinstalled after procedure is complete.

1. Start the machine.
2. Turn steering wheel to the right or left.
3. When the wheels stop turning, continue to turn the steering wheel 3 to 4 full revolutions (this will put the cylinders back in phase with each other).

**Step 2 - Set Toe-In**

**Front Wheels**

- .25" (.6 cm) Toe-In per side/0.5" (1.3 cm) total Toe-In

**Rear Wheels**

- 0" (0 cm) Toe-In/Out

**To Set Toe-In**

1. Deflate the air bags.

*NOTE: Refer to "Air Suspension Exhaust" provided in the Miscellaneous Section elsewhere in this manual for further information.*

2. Measure the distance from the ground to center of wheel hub.

*NOTE: All four wheel hubs should measure the same distance.*

3. Mark this distance on the inner edge of the wheel rim (front and back of each rim - 8 marks total).

*NOTE: All measurements will be taken from these markings.*

4. Visually align the tires from front to rear.

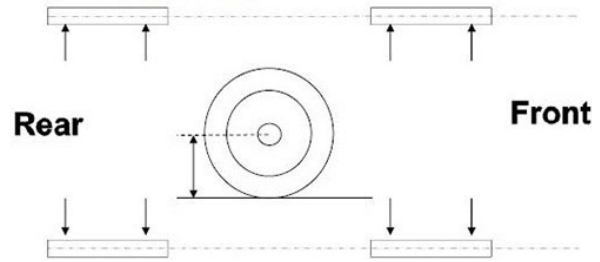

**Front Wheels**

5. Measure the width between the front wheels (front W1, rear W2) at the wheel hub center line and record measurements.
6. Adjust the wheels until the front and rear measurements are equal (W1=W2).
7. Measure diagonally (D1 and D2) and record the measurements.
8. Adjust the wheels until the measurements are equal.



9. Continue to cycle between Steps 5-6 and 7-8 until the width measurements match and the diagonal measurements match. Then and only then are the wheels parallel to each other and the frame.

*NOTE: To achieve this, both conditions must be met.*

**NOTE: The front steering cylinders must both be centered before proceeding!**

10. Set both cylinders to center by measuring 7.64" (19.4 cm). The position sensors should both read 4.4" (11.2 cm) when the

cylinders are centered and in phase (10.A).

*NOTE: This is not required for All-Wheel Steer (AWS) machines, as the cylinder position sensors can be used to center the cylinders.*

- *The cylinder sensors must be calibrated for this position to be accurate.*
- *If the cylinders do not center at this measurement, they are not in phase. To re-phase the cylinders, turn the steering wheel so that one cylinder is fully retracted and the other is fully extended. Turn the steering wheel at least one full turn past this point. Re-center the cylinders. If the measurements still do not match, repeat the cylinder air bleed procedure.*



11. With the cylinders centered, adjust the tie-rods (located on the cylinder rods) until they line up with the bolt-down hole (located on the lower air bag plate).
12. Turn the tie-rod one more full turn to achieve desired amount of toe-in.
  - *When the rod ends are turned the final turn (to establish the desired amount of toe-in), the rod ends turn in opposite directions to get each wheel in toe.*
  - *If the amount of threads showing on the left and right-hand rod ends differ by more than four (4) threads, repeat previous Steps 1-12. If the difference remains, there may be a tolerance issue in the leg assembly.*
13. Pry wheel in to allow rod end securing bolt to be inserted.
14. Insert bolt and torque main bolt and cylinder jam nut to proper specification.

### Rear Wheels

*NOTE: Rear wheels should be set to 0.0" (0.0 cm) toe in/out.*

15. Repeat previous Steps 1-9.
16. **(Non-AWS Machines)** - Set tie rod assembly to match up with the bolt-down hole (located on the lower air bag plate). Insert bolt and secure to the proper torque specification (refer to "Torque Values" provided in the *Introduction Section* elsewhere in this manual for further information).
17. **(AWS Machines)** - Repeat Step 10, centering the rear cylinders at 4.4" (11.2 cm). Insert bolt and torque main bolt and cylinder jam nut to proper specification.

*NOTE: The cylinder sensors must be calibrated for this position to be accurate.*

- *The machine should be driven and toe (front and rear) rechecked.*
- *Front steering cylinders must be in phase when toe setting is checked.*
- *Failure to hold toe setting could indicate the presence of air in the cylinders.*
- *Repeat the cylinder bleeding procedure, if necessary.*

### Further Information

Contact your local John Deere dealer if additional assistance is needed.

---

## SERVICE - MISCELLANEOUS

### Air Bags

The Air Bags (one located on each leg) automatically adjust pressure to compensate for load weight and field conditions.



**Air Bag**  
(Located on each leg)  
-Typical View

The system includes an Air Dryer (mounted on the rear left-hand engine frame) that removes moisture from the air system before sending it to the collection tank.

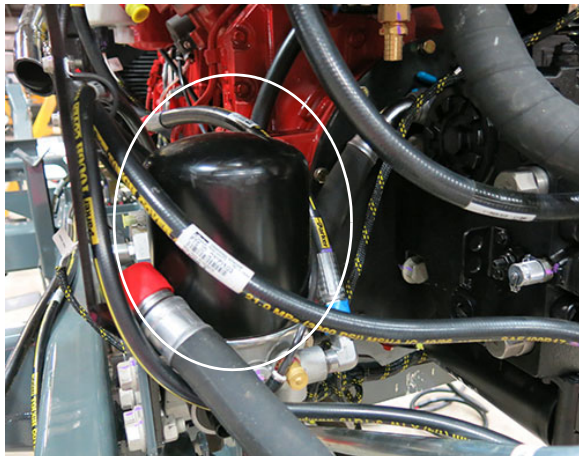

**Air Dryer**  
(Mounted on the rear  
left-hand engine frame)  
-Typical View

From the collection tank, air is sent to the Air Bags as needed to maintain a level pressure. Control valves open and close to allow air in.

- Inspect Air Bags daily for leaks and/or cracking. If an Air Bag is low, check the bag for any punctures or leaks.
- Inspect the Air Dryer cartridge every 50 hours of operation to ensure that it is purging with compressor load. Change the cartridge every 1,000 hours of operation, or as needed.

Contact your local John Deere dealer if assistance is needed.

### **Air Tanks**

#### **⚠ CAUTION**

Air system at high pressure can discharge debris or components. Wear protective eyewear. Before servicing, relieve all system air pressure.

N404969

#### **IMPORTANT**

**DRAIN MOISTURE FROM  
AIR TANK DAILY**

N209334

Your machine may be equipped with two Air Tanks. The **Main Air Tank - standard** (located beneath platform on the rear right-hand side of machine) provides a volume of compressed air to give faster response for changes in air volume to the air bags.

The **Air Purge Tank - if equipped** (located beneath platform near the center right-hand side of machine) is used to push solution out of the boom line, reducing the amount of rinse water needed to clean the solution system of chemical.

- Drain each Air Tank daily by slowly releasing the Tank Drain Valve.

**Tire Pressure**

**⚠ CAUTION**

When inflating tire, use an extension with an in-line air gauge and attach air chuck. This will allow the operator to stand clear of tire sidewall explosion trajectory.

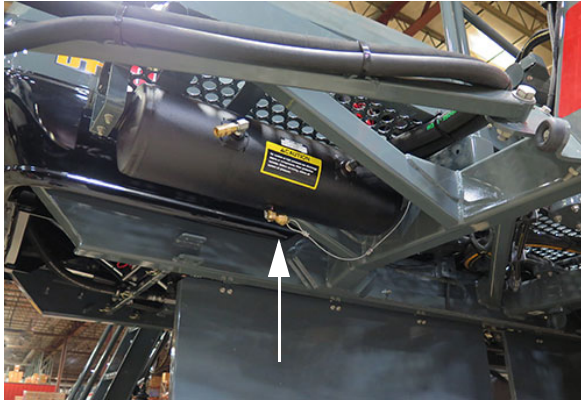

Tank Drain Valve (Main)  
(Located beneath platform on rear right-hand side of machine)  
**\* Pull DOWN to open**  
-Typical View



Tank Drain Valve (Air Purge) - *if equipped*  
(Located beneath platform near center right-hand side of machine)  
**\* Pull DOWN to open**  
-Typical View

**NOTE:** Check for moisture. If excessive moisture is in the tank(s), there may be a system malfunction. Contact your local John Deere dealer if assistance is needed.

- Check tire pressure weekly.
- Never inflate a tire more than the recommended maximum air pressure.
- Use an airline with a locking air chuck and stand behind the tire tread while filling.

**NOTE:** Tire pressure will depend on type of tire used and amount of load.

**Tall Crop Package Machines**

**-If Equipped**

If your machine is equipped with the Tall Crop Package, perform the following steps to access the tire valve stem:

1. Using a 5/32" hex wrench, remove the button-head screw (located on the wheel access panel) and set aside.
2. Using a 7/16" socket wrench, loosen the hex bolt (located on the wheel access panel) and allow panel to hang loose.

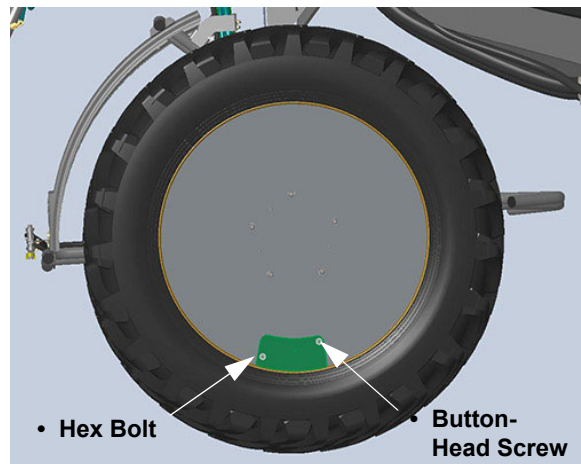

-Typical View

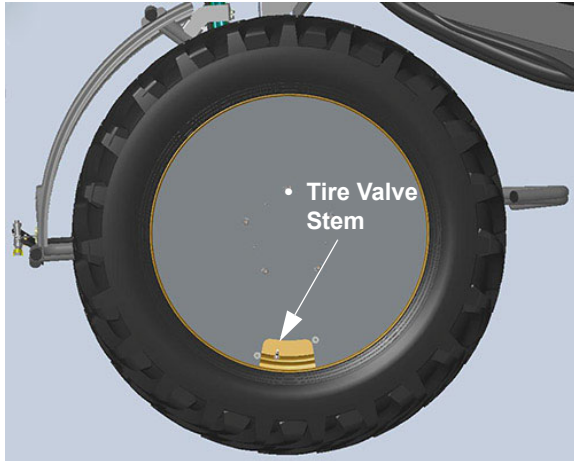

-Typical View

3. Check tire pressure and inflate as desired.
4. Reverse steps to reinstall wheel access panel.

### Spray Booms

**⚠ CAUTION**

Never place a spray tip/nozzle to your mouth in an attempt to unplug it.

#### Nozzle Diaphragms

At the beginning of each season, remove each nozzle body cap and inspect the diaphragm for wear and fit. Replace diaphragms every 1,000 hours of operation, or as necessary.

#### Spray Tips

At the beginning of each season (or as required), remove a random sample of spray tip caps and inspect the nozzle tips. If the tips are plugged or worn, clean or replace them. Replace spray tips every 1,000 hours of operation, or as necessary.

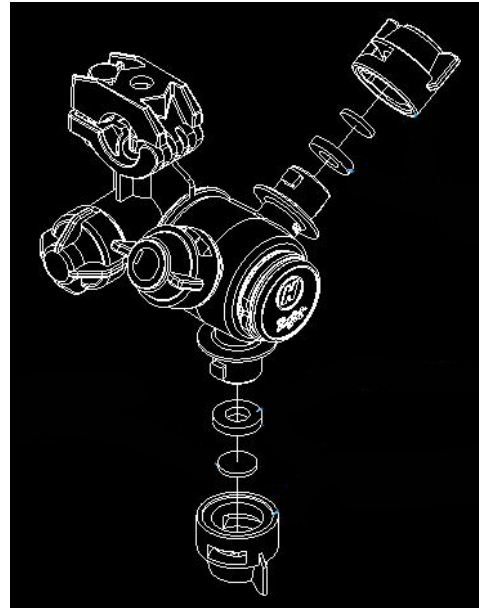

Nozzle Diaphragms and Spray Tips  
-Typical View

### Wiper Blade

**NOTICE**

Use a sturdy stationary ladder to safely access the wiper blade.

Do not allow the Wiper Blade to run on a dry windshield, as this will shorten the life of the blade and/or cause scratching on the windshield.

*NOTE: Replace the windshield wiper blade (39"/99 cm) as necessary.*

The Windshield Washer Fluid Spray Nozzle is adjustable. The fluid spray pattern should be inspected at the beginning of each season, and adjusted as necessary.

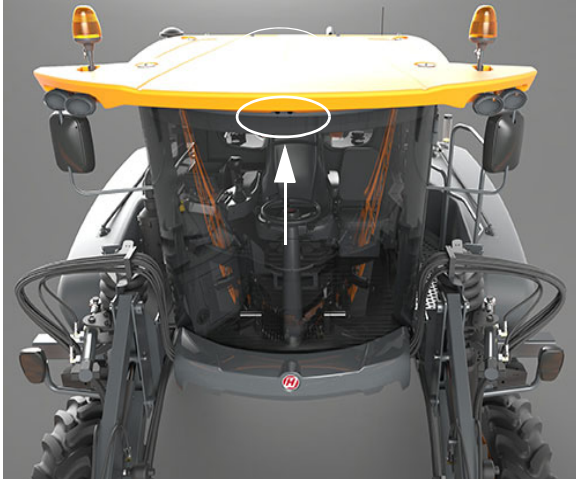

Windshield Washer Fluid Spray Nozzle  
(Located near top of exterior cab)  
-Typical View

## Washing the Machine

Wash the machine daily to remove any harmful chemical residue, which can be corrosive to paint and steel.

*NOTE: Always wash machine thoroughly after applying liquid nitrogen.*

As often as possible, thoroughly wash the machine and apply paint to any place where the paint is light or missing.

For replacement decals or touch-up paint recommendations, contact your local John Deere dealer.

**SERVICE INTERVALS**

Service Point	Initial	Daily/ Before Each Use	As Required	50 Hrs.	100 Hrs.	250 Hrs. **	500 Hrs. **	1000 Hrs.
Check Lug Nut Torque (Break-in)	X							
Check Engine Oil Level		X						
Check Radiator Coolant Level		X						
Check Radiator Grille Screen		X						
Check Engine Drive Belt		X						
Check Hydraulic Reservoir Level		X						
Check Solution Line Strainer		X						
Check Batteries		X						
Check for Leaks Around the Machine		X						
Drain Air Tanks		X						
Check Windshield Washer Fluid Level		X						
Wash Machine Clean of Chemical Residue		X						
Check and Drain Primary Fuel Filter (Water Separator)		X						
Check Air Bags		X						
Check Tread Adjust Bearing Bolts (Visually)		X						
Check Engine Air Intake Piping		X						
Check Aftertreatment DEF Tank Level (Final Tier 4 Engines)		X						
Check Aftertreatment DEF Exhaust Piping (Final Tier 4 Engines)		X						
Lubricate Leg Grease Zerks			X					
Replace Windshield Wiper Blade			X					





## SECTION 8 – MAINTENANCE AND STORAGE

Service Point	Initial	Daily/ Before Each Use	As Required	50 Hrs.	100 Hrs.	250 Hrs. **	500 Hrs. **	1000 Hrs.
Fill Windshield Washer Fluid Reservoir			X					
Clean Radiator Grille Screen			X					
Change Engine Drive Belt			X					
Charge A/C Compressor *			X					
Change Air Intake Filter (Filter Minder)			X					
Clean/Replace Solution Line Strainer			X					
Check Spray Nozzle Diaphragms and Tips			X					
Change Tread Adjustment Bearing Torque			X					
Change Batteries			X					
Change or Replace Fuses and Breakers			X					
Replace Charcoal Cab Filter			X					
Clean Cab Recirculation Filter			X					
Check Tire Pressure			X					
Inspect/Clean/Lubricate Tread Adjust Bearing Slide Path			X					
Lubricate Boom Outer Fold Joint Rod End Grease Zerks				X				
Lubricate Air Bag Collar Grease Zerk				X				
Check Lug Nut Torque				X				
Lubricate Ladder Pivot Tube Grease Zerk				X				
Change Wheel Hub Oil (Break-in)				X				
Check Air Dryer Cartridge				X				
Check Wheel Hub Oil Level					X			
Clean Batteries					X			
Check Tread Adjust Bearing Bolt Torque					X			

## SECTION 8 – MAINTENANCE AND STORAGE



Service Point	Initial	Daily/ Before Each Use	As Required	50 Hrs.	100 Hrs.	250 Hrs. **	500 Hrs. **	1000 Hrs.
Change Wheel Hub Oil						X		
Change Engine Oil							X	
Change Engine Oil Filter							X	
Change Primary Fuel Filter (Water Separator)							X	
Change Secondary Fuel Filter							X	
Change Hydraulic Return Filter							X	
Change Hydraulic Pressure Filter							X	
Change Hydraulic Charge Pump Filter							X	
Change Hydraulic Tank Breather Cap							X	
Check Radiator Coolant Concentration							X	
Change Hydraulic Reservoir Oil								X
Replace RESPA® Cab Filter								X
Change Radiator Coolant								X
Change Air Dryer Cartridge								X
Change Spray Nozzle Diaphragms and Tips								X
Exhaust Brake Service (contact engine manufacturer)								X

\* Use proper equipment.

\*\* 250-500 hours or yearly, whichever occurs first.

**NOTE: Final Tier 4 Engines** - Replace Aftertreatment Diesel Exhaust Fluid (DEF) Supply Module Filter every 4,500 hours of operation. Refer to the engine manufacturer's operation manual for further information.

## STORAGE

### Preparing For Storage

1. Perform daily level checks, lubrication, and bolt/linkage inspections, as required in this manual.

2. Every other season, drain the coolant from the engine and radiator. Probe the drain holes during drainage to ensure they are not clogged by sludge, scale, or other deposits.  
Fill the cooling system to the top with a 50/50 water/antifreeze mixture. Run the

engine to operating temperature and recheck level.

3. Add a fuel stabilizer to the fuel and fill the tank.
4. Run the engine until it reaches operating temperature, then drain the engine oil. Refill with fresh oil of recommended weight and install a new lubricating oil filter element.
5. With the engine at normal operating temperature, cycle all hydraulic functions, including the steering.
6. Release tension on all belts.
7. Use plastic bags and water-resistant adhesive tape to seal the air intake opening, all exhaust manifold openings, engine oil fill cap, hydraulic oil tank breather cap, and fuel tank cap.
8. Final Tier 4 Engines - Plug the Diesel Exhaust Fluid (DEF) tank venting to seal tank exposure against environmental elements.
9. Turn the Battery Disconnect Switch OFF.
10. Disconnect and remove batteries. Completely clean and charge the batteries. Coat the terminals with dielectric grease and store the batteries in a cool place (above freezing).
11. Thoroughly wash the machine and spray boom. Touch up any painted surfaces that are scratched or chipped.

*NOTE: For paint touch-up recommendations, contact your local John Deere dealer.*

12. Replace worn or missing decals. Refer to “Safety Decals” in the *Safety and Precautions Section* for proper location of warning decals and corresponding part number.

*NOTE: For decal replacement, contact your local John Deere dealer.*

13. Apply multi-purpose grease to coat exposed hydraulic cylinder rods.
14. Refer to the Spray System Console manufacturer’s operation manual for detailed information on storage procedures for the console and flow meters.
15. If the machine must be stored outside, cover with a waterproof cover.

### Winterization

To winterize the spray system, it is recommended that you use an environmentally safe RV-type antifreeze and water mixture that will give you adequate protection to -30° F.

- Drain any remaining solution in the spray system.
- Thoroughly rinse the spray system.
- Run antifreeze/water mixture through the spray system until it comes out all of the boom openings.

*NOTE: Ensure the Agitation Valve Switch (located on the side console) is in the OPEN position before running antifreeze/water mixture through the system.*

Repeat process for both the Foam Marker and Rinse Systems.

### Winterizing the Hand Wash System

1. Open desired Hand Wash Valve (located at the left-hand platform handrail or the ladder) and allow fresh water to drain from hand wash reservoir.

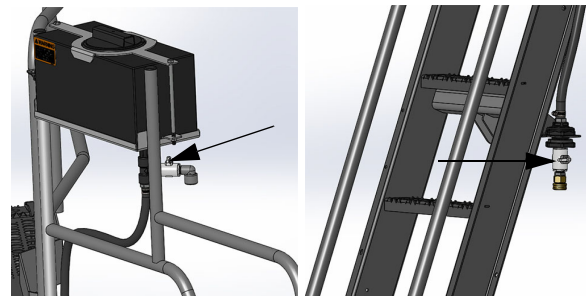

Hand Wash Valve  
(Left-Hand  
Platform Handrail)

Hand Wash Valve  
(Ladder)  
-Typical View

2. Close the Hand Wash Valve after all water is removed from hand wash reservoir.

*NOTE: Ensure BOTH Hand Wash Valves are in the CLOSED position before adding antifreeze.*

3. Remove the Hand Wash Fill Lid (located on top of the hand wash reservoir) and pour approximately 1 gallon (3.8L) of RV-type antifreeze into opening.

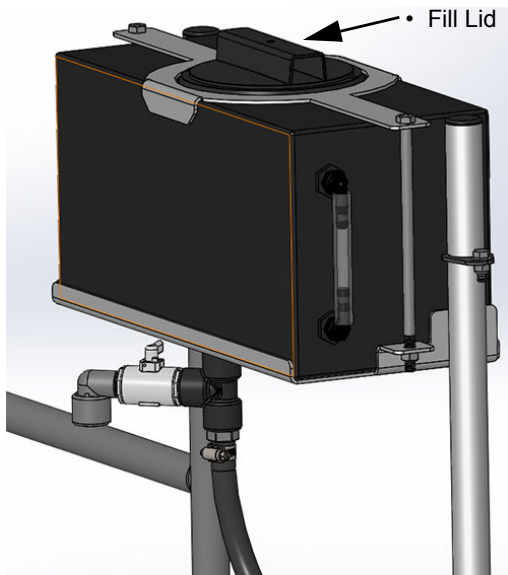

Hand Wash Reservoir  
(Located on the left-hand platform handrail)  
-Typical View

4. Open **both** Hand Wash Valves (located at the left-hand platform handrail and ladder stations) until no antifreeze comes out of the hand wash outlets.
5. Close both Hand Wash Valves when finished.

### Removing From Storage

#### **NOTICE**

Protective compounds such as grease can harden under exposure to weather conditions. Be sure to remove any dried grease and reapply new, if necessary.

1. Inspect the condition of and test the air pressure of all tires.
2. Carefully unseal all openings that were previously sealed in the “Preparing for Storage” process.
3. Clean and reinstall the batteries. Be sure to attach the battery cables to the proper terminals.
4. Tighten all belts. Inspect and replace any worn belts.

5. Check the engine oil, hydraulic oil, and engine coolant levels, and add if necessary.

*NOTE: A mixture of 50/50 water/antifreeze will cool adequately in the summer, as well as protect in winter.*

6. If the Hand Wash System was winterized prior to storage, fill hand wash reservoir with fresh water and drain before use.
7. Thoroughly clean the machine and spray boom.
8. Perform all recommended services as instructed elsewhere in this section.
9. Manually cycle all spray boom hydraulic functions 2 or 3 times to thoroughly lubricate the components. Test the NORAC® system and all of its functions according to the manufacturer’s operation manual.
10. Reset date and time on Machine Display.
11. For starting instructions, refer to “Engine - Starting” provided in the *Engine and Drive Systems Section* elsewhere in this manual.



## SECTION 9 – MISCELLANEOUS

### TRANSPORTING

When driving the machine on a public roadway or elsewhere, be aware of any situation where the sprayer will be passing under an object with a clearance lower than the transporting height of the machine. Refer to “Specifications” provided in the *Introduction Section* elsewhere in this manual for further information.

#### **⚠ WARNING**

- Never operate the sprayer on a public roadway with solution in the tanks.
- Never load or unload the sprayer with solution in the tanks.
- Stopping the sprayer on trailer ramps may result in the sprayer to tip over.

#### **⚠ WARNING**

- When transporting the sprayer, observe the following to avoid serious injury or death:
- Check for adequate clearance before driving under any overhead obstructions.
  - Contact with power lines may result in serious injury or death.



#### **⚠ CAUTION**

Avoid collisions. Before transporting machine on a public roadway, check and follow local regulations regarding size limits, the use of lights, flags, signs, pilot vehicles, and other requirements for transporting loads using trailer.

#### **⚠ CAUTION**

Ensure the booms are folded and in cradles before transporting the machine. Failure to comply may result in injury or equipment damage.

#### **⚠ CAUTION**

Do not operate the machine at speeds exceeding 20 mph (32 km/h) with solution in the tanks. Operating speeds exceeding 20 mph (32 km/h) with fully loaded tanks may result in tire blow-out or wheel hub damage and will void the warranty.

### Cradling the Booms

#### **⚠ CAUTION**

Booms must be in FOLDED position when cradled. Failure to comply will result in property damage.

## SECTION 9 – MISCELLANEOUS



*NOTE: Always cradle the booms before traveling, transporting, or parking for an extended period of time.*

- Fold the outer boom extensions IN.
- Raise the transom all the way UP.
- Fold main boom sections IN toward the machine.

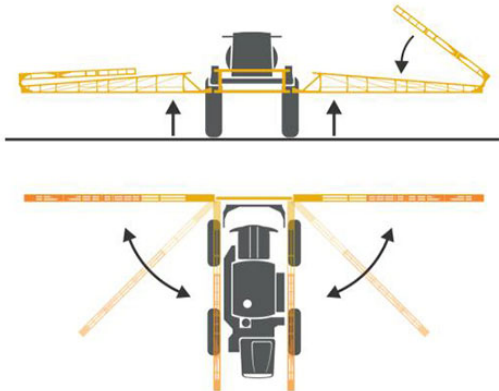

*NOTE: When boom reaches the last 8-10 degrees of travel, it will automatically slow down to avoid impact with the cradle.*

- Raise each individual boom until it clears the outer cradle stop.
- Fold the boom IN toward cradle back-stop.



- When boom touches the back-stop, lower until the full weight of the boom rests in the cradle.



### Driving the Sprayer on a Public Roadway

1. Always have the booms in the folded and cradled position when driving or transporting the machine.
2. Transport machine at narrowest tread adjust setting only.
3. Use the flashing hazard/warning lights, day or night to warn other drivers, unless prohibited by law.
4. Know and obey all state laws for driving agricultural equipment on a public roadway.
5. Adjust machine speed to suit the conditions.
6. Slow down and use turn signals before turning.
7. Pull over to the side of the road before stopping.
8. Keep a proper lookout and maintain control of the machine.
9. Do not drive under trees, bridges, wires, or other obstructions unless there is adequate clearance.
10. Use extra care before entering or exiting a public roadway.
11. Ensure the SMV (Slow Moving Vehicle) and SIS (Speed Indicator Symbol) emblems are properly displayed to warn other drivers, unless prohibited by law.
12. Do not drive the machine at speeds exceeding 20 mph (32 km/h) with solution in the tanks. Operating speeds exceeding 20 mph (32 km/h) with fully loaded tanks may result in tire blow-out

or wheel hub damage and will void the warranty.

## Transporting Machine Using Trailer

### Loading

**⚠ WARNING**

Keep all persons away from trailer when loading or unloading the sprayer. Failure to comply may result in serious injury or death.

**NOTICE**

Read and understand the trailer manufacturer's operation manual. Hitch the trailer to the pulling vehicle according to their recommendations.

**NOTICE**

The loaded height and width of the trailer must conform to state law in which it is being used. Do not exceed the trailer manufacturer's recommendations on loaded weight.

1. Pull the trailer to flat ground.
2. Apply the pulling vehicle's parking brake and turn the engine OFF.
3. Use tire chocks to keep the trailer from moving.
4. Fold the booms and lower into cradles.
5. Lower the trailer ramps and set the ramp spacing for the machine's tread width setting.
6. Have an attendant help guide you onto the trailer.
7. Allow enough room between the sprayer and the pulling vehicle for turning.

8. Secure the sprayer onto the trailer using the recommended securement restraints (see trailer manufacturer's operation manual).
9. Cover or remove the SMV (Slow Moving Vehicle) and SIS (Speed Indicator Symbol) emblems when traveling over 30 mph (50 km/h).

### Unloading

1. Pull the trailer to flat ground.
2. Apply the pulling vehicle's parking brake and turn the engine OFF.
3. Use tire chocks to keep the trailer from moving.
4. Lower the trailer ramps and set the ramp spacing for the machine's tread width setting.
5. Carefully release the securement restraints.
6. Have an attendant help guide you off of the trailer.
7. Uncover or replace the SMV and SIS emblems.

---

## TOWING

**IMPORTANT**

To tow or pull the sprayer, the engine **MUST** be running and the hydraulic system **MUST** have correct hydraulic pressure or damage **WILL** occur to the brakes and wheel hubs. If engine is not running or proper hydraulic system pressure cannot be maintained, see your John Deere dealer.

The machine should only be towed with the engine running, correct hydraulic pressure, and the machine's parking brake disengaged. Only tow the machine a short distance and at a speed not exceeding 3 mph (5 km/h). Towing the machine more than 100 meters is not recommended.

## IMPORTANT

- The following towing procedure is intended for short distance emergencies only. If long distance towing is necessary, transport disabled machine on a trailer.
- Before towing the machine, ensure towing apparatuses are in good condition and have sufficient mechanical strength for towing the machine.
- Keep the tow angle to a minimum of 30° or less from the straight-ahead direction.
- Maintain gradual and smooth machine movement when towing.
- An additional tow vehicle behind the machine is required when towing a disabled machine in order to provide sufficient control and braking.

*NOTE: Machine is not equipped with an “emergency steering pump” power source. Therefore, manual user input of the steering wheel is required to steer the machine while towing.*

### Towing the Machine

1. Lower the front end cap (1A).  
Refer to “Front End Access” elsewhere in this manual for further information.

## CAUTION

Lower the front end cap as directed. Failure to comply may result in personal injury.



### CAUTION

CRUSH HAZARD.  
RISK OF INJURY DUE TO IMPROPER OPERATION. REFER TO OPERATOR'S MANUAL FOR INSTRUCTION.



2. Attach two (2) suitable chains or straps to the two provided tow hooks (2A).

*NOTE: The machine will be pulled from these two chains/straps.*

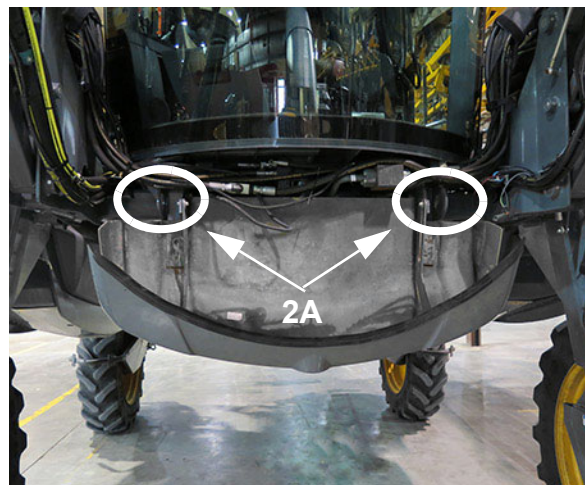

3. Attach two (2) suitable chains or straps to the rear axle tubes (as close to the



mainframe as possible). **These chains/straps will be used to brake the machine once it is moving, as the machine will not be capable of stopping itself.**

*NOTE: If the chains/straps contact other components while towing, those components should be removed or the chains/straps relocated prior to towing.*

*NOTE: A vehicle of comparable size and weight should be used to tow the machine and a larger vehicle capable of stopping the machine should be attached to the rear of machine for braking and stopping.*

4. **If engine is able to run**, start the engine and disengage the parking brake.

*NOTE: If ladder does not raise, the parking brake is not disengaged. Contact your John Deere dealer for towing assistance.*

5. Pull the machine forward to the nearest safe location at a slow speed not exceeding 3 mph (5 km/h). **Engage the parking brake before removing the tow chains/straps.**

**If engine is not able to run**, contact your John Deere dealer for towing assistance.

---

## LIFTING YOUR MACHINE

### **WARNING**

Do not lift machine by more than one or two lifting points at the same time. Failure to comply will cause the machine to become unstable, resulting in serious injury or death.

### **WARNING**

Use extreme caution when supporting machine by a lifting point. Failure to obtain proper location and lifting equipment may cause the machine to become unstable, resulting in serious injury or death.

### **NOTICE**

Lift machine on hard level surface with properly rated equipment only.

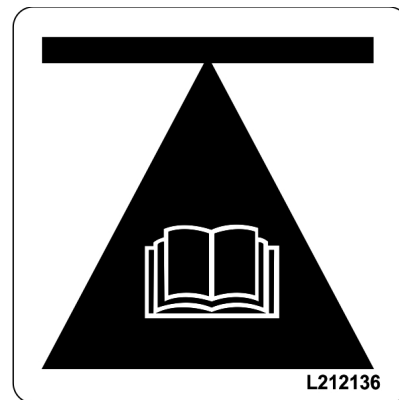

RISK OF INJURY DUE TO IMPROPER LIFTING.  
DO NOT ATTEMPT TO LIFT MACHINE  
WITHOUT JACKS PROPERLY SEATED IN THE  
LIFTING POINT CONTAINMENT RINGS.

There are four (4) designated lifting points on the machine. These points are located on the frame near each leg and are equipped with containment rings for safe jack location.

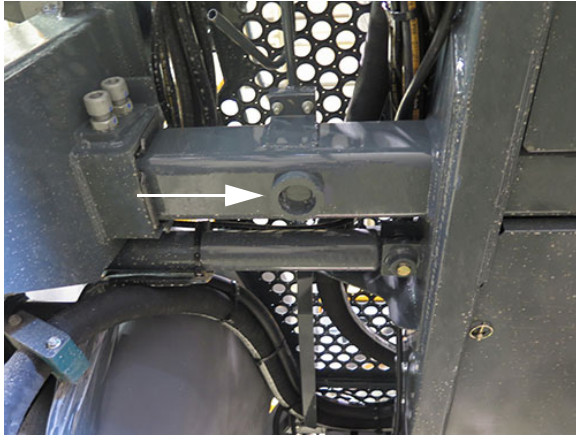

Lifting Point Containment Ring  
(Located on the frame near each leg)  
-Typical View

### **To Lift Machine (Bottle Jacks)**

1. Shut the engine off.

*NOTE: The parking brake will engage automatically when the engine is shut off.*

2. Place wood blocks in front and rear of the tires not being lifted.
3. Align jack with Lifting Point Containment Ring.

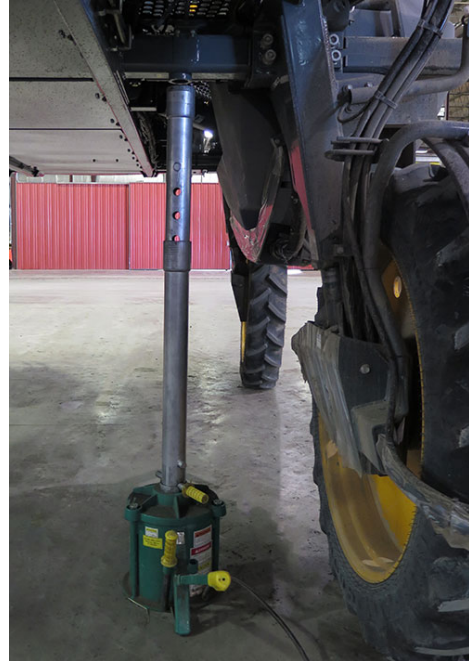

Align Jack with Lifting  
Point Containment Ring  
-Typical View

4. Connect air supply to jack.
5. Tap air supply handle and slowly insert jack around Lifting Point Containment Ring.



Insert Jack Around Lifting  
Point Containment Ring  
-Typical View

6. Once jack is fully seated around the Lifting Point Containment Ring, continue to press and hold air supply handle until the machine reaches desired height.

 **WARNING**

Ensure lock pins are fully inserted at base of jack. Do not rely on jack air supply to support a raised machine. Sudden loss of air pressure will cause the machine to become unstable, resulting in serious injury or death.

7. Install Lock Pins to the base of jack.



Lock Pin Installation  
-Typical View

8. Reverse steps to lower machine.

---

## AIR SUSPENSION EXHAUST

### (Air Bags)

The Air Bags simulate a spring and shock suspension, providing a smooth, consistent ride quality. A ride control valve automatically increases/decreases compressed air into the air bags to maintain ride height position as load or wheel position changes with ground level.

*NOTE: Inspect air bags daily for leaks and/or cracking.*

### To Deflate Air Bags

- Push the sleeve around the black tube on the Air Bag Connection Hose IN and pull hose out.
- Repeat on each Air Bag as desired.

### To Inflate Air Bags

- Reconnect Air Bag Connection Hose.

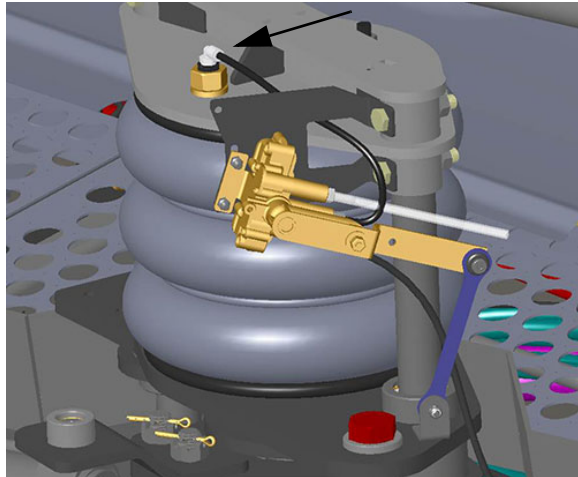

**Air Bag Connection Hose**  
(Located on top of each air bag)  
-Typical View

## VISCOUS CLUTCH FAN

### -If Equipped

*NOTE: If your machine is equipped with the Variable Pitch Reversible Fan, refer to the Hydraulic Section elsewhere in this manual for further information.*



## **WARNING**

Improper operation, maintenance, or repair of this product can be dangerous and may result in serious injury or death.

- Always use Hagie-approved parts and components. Failure to comply will result in voiding the 1-year parts warranty.
- Do not operate or perform any service on this product until you have read and understand the operation and maintenance information. Contact your local John Deere dealer for any additional information that you may require.
- The person(s) servicing the product may be unfamiliar with many of the systems or components of the product. Use caution when performing service. Knowledge of the product and components are important before the removal or disassembly of any component.

## **NOTICE**

The fan system reduces power and fuel consumption of the engine when full airflow is not required to keep the engine cool.

The automatically controlled Viscous Clutch Fan uses special fluid and valves to vary the speed of the fan with inputs from an Electronic Control Unit (ECU) based off of temperature readings from the cooling system, which provides precision fan control, increased cooling performance, improved fuel economy, and less noise. The fan is direct engine-mounted and consumes up to 30 hp (22 kw) at full speed.

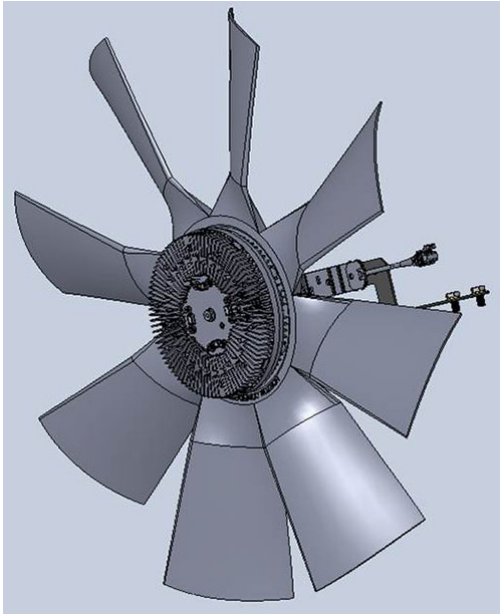

Viscous Clutch Fan  
(Located near the rear of machine  
- open hood to access)  
-Typical View

### Before Starting the Engine

1. Ensure all hoses and wires are adequately secured and routed away from the fan operating area.
2. Ensure all tools have been removed from the engine compartment, including the top side of the radiator and inside of the shroud before the fan guards are installed. Obstacles in the path of rotation can interfere with movement of the fan and can result in damage to the fan blades, fan hub, and radiator core.
3. Inspect the radiator shroud mounting bolts to ensure that the radiator and shroud are firmly secured and unable to move during operation of the machine. Loose shroud bolts can allow the fan shroud to move into the path of the rotating blades and loose radiator mounting bolts can allow the radiator to flex in position, allowing the shroud to come into contact with the rotating fan blades.
4. Ensure all fan guards have been installed and firmly secured into place. The Reversible Fan creates an abundant amount of airflow in both cooling and

cleaning mode operation. The result of this airflow is a strong vacuum effect that can suck in items that are located inside or around the engine compartment fan.

5. To ensure maximum efficiency, start with a clean cooling system free of debris, paying particular attention to the stacked cooler core(s).

### Service and Maintenance

#### **WARNING**

Ensure the Battery Disconnect Switch is OFF before performing any service on the fan. Failure to comply may result in engine turnover, serious injury, or death.

Under normal operating conditions, the Reversible Fan does not require scheduled maintenance (other than lubrication) and is built to provide thousands of hours of trouble-free service.

In moderate to extreme operating conditions, a visual inspection of moving parts is recommended from time to time to safeguard against fan blade damage, which could lead to equipment and/or other damage.

### HAND WASH SYSTEM

#### **WARNING**

**Do not drink from this container. Container may become contaminated by sprayer chemicals. Fill with clean water only.**

N408864

**⚠ CAUTION**

The Hand Wash System is not a substitute for Personal Protective Equipment (PPE). Always use the proper PPE (i.e. safety eye wear, face shields, protective clothing, etc.) when handling chemicals.

**NOTICE**

Keep the hand wash reservoir full of fresh water at all times for immediate use should contact with hazardous chemicals occur.

**NOTICE**

Fill the hand wash reservoir with fresh water only.

**NOTICE**

The Hand Wash System has been tested using RV-type antifreeze. Fill hand wash reservoir with fresh water and drain before initial use.

Your machine is featured with two Hand Wash Stations - one mounted on the ladder and the other mounted on the left-hand platform handrail for your convenience in rinsing dirt and chemicals from hands before entering the cab.

**Filling the Hand Wash Reservoir**

*NOTE: Hand Wash Reservoir Capacity = 4 gallons (15L).*

- Remove the Hand Wash Fill Lid (located on top of the hand wash reservoir) and pour fresh water into opening.

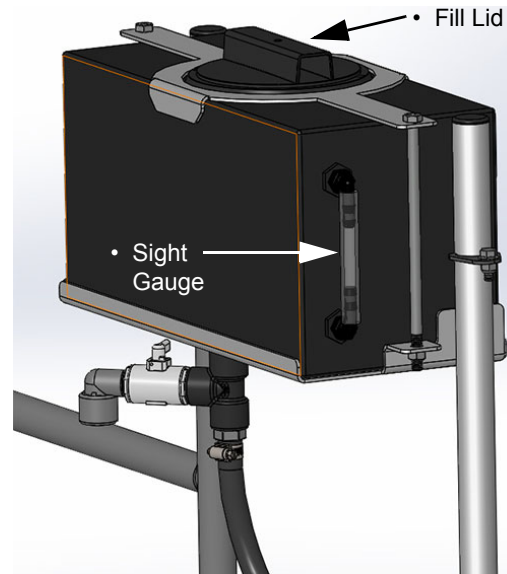

Hand Wash Reservoir  
(Located on the left-hand platform handrail)  
-Typical View

- NOTE: A sight gauge is located on the side of the Hand Wash Reservoir to visually check water level.*
- Reinstall the Hand Wash Fill Lid when finished.

**Dispensing Fresh Water**

- Rotate the desired Hand Wash Valve (at the left-hand platform handrail or ladder station) in the “counter-clockwise” position to OPEN.
- Rotate valve in the “clockwise” position to CLOSE.

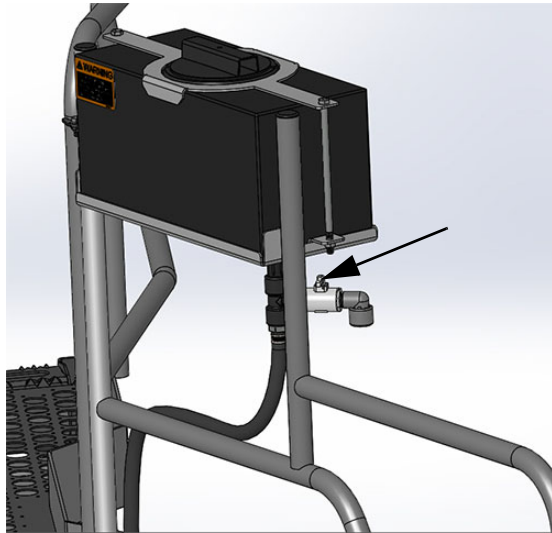

Hand Wash Valve  
(Left-Hand Platform Handrail)  
-Typical View

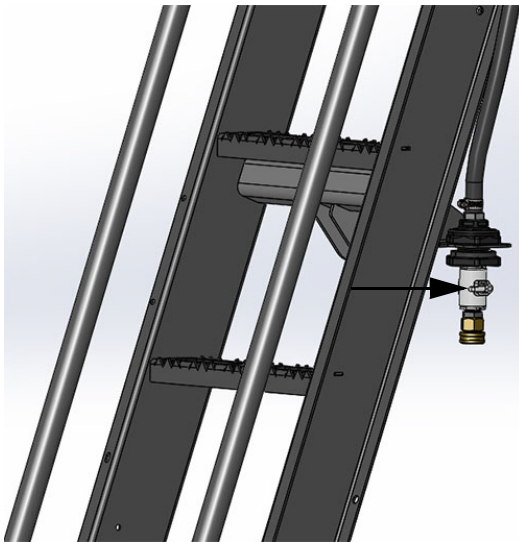

Hand Wash Valve  
(Ladder)  
-Typical View

## ELECTRIC HOOD

### NOTICE

Do not operate machine with the hood open. Failure to comply may result in property damage.

The rear hood is equipped with an electric hood actuator, which allows the hood to be opened and closed by the touch of a switch.

### To Open Hood

- Press and hold the Hood Actuator Switch (located near front of hood above the radiator screen) in the OPEN (Left) position.

*NOTE: If the hood does not open upon activation, release the Hood Actuator Switch and try again.*

- Release Hood Actuator Switch when hood has opened to desired position.



Hood Actuator Switch  
(Located near front of hood  
above the radiator screen)  
-Typical View

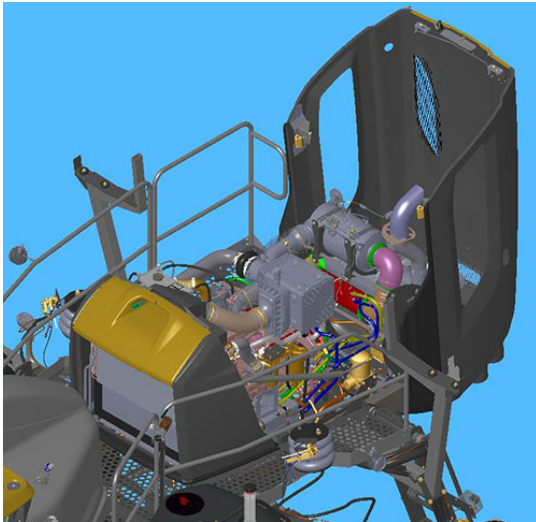

Rear Hood  
(Open position shown)  
-Typical View

### To Close Hood

- Press and hold the Hood Actuator Switch in the CLOSE (Right) position until hood is fully retracted and comes to a complete stop.



Rear Hood  
(Closed position shown)  
-Typical View

### Powering the Hood Actuator (when battery charge is depleted)

Refer to “Engine - Starting” provided in the *Engine and Drive Systems Section* elsewhere in this manual for information on jump starting the machine.

## FRONT END ACCESS

Your machine is featured with a fiberglass front end cap, which can be lowered to access items such as:

- Steering Valve
- Auto Steer Connection to Steering Valve
- Steering Angle Sensor Absolute (SASA) Sensor
- Drive Hose Connections
- Brake Hose Connection
- Pressure, Tank, and Excess Flow Connections (Auxiliary Functions)
- Horn/Electrical Connections
- Front Headlight Harness Connection

### To Lower Front End Cap

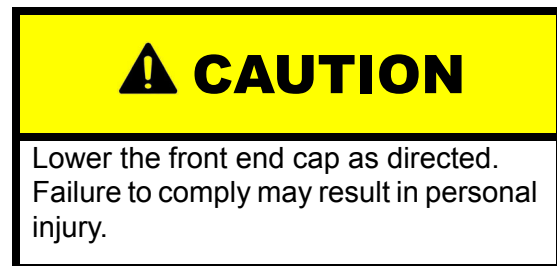

**CAUTION**  
CRUSH HAZARD.  
RISK OF INJURY DUE TO IMPROPER  
OPERATION. REFER TO OPERATOR'S  
MANUAL FOR INSTRUCTION.

1. Using a 7/16” wrench, remove the two (2) mounting nuts/bolts (located beneath front end of machine) and set aside.





Mounting Nuts/Bolts (2)  
(Located beneath front end of machine)  
-Typical View

2. Standing behind the front end cap with one hand supporting the front of cap and the other hand near the rear center of cap (as shown in the following photo), push front end cap OUTWARD (toward front of machine) and lower.



-Typical View



Front End Cap  
(Lowered position shown)  
-Typical View

3. Reverse steps to raise front end cap to stored position, ensuring the mounting nuts/bolts are reinstalled.

## TREAD ADJUSTMENT - MANUAL

### -If Equipped

*NOTE: Refer to the Hydraulic Systems Section elsewhere in this manual for information on adjusting Hydraulic Tread Width (if equipped).*

Your machine may be equipped with Manual Tread Adjust to boost capability and perform applications for various field row widths and cropping stages with minimal crop damage.

### Tread Range

- Minimum Tread Width = 120" (304.8 cm)\*
- Maximum Tread Width = 160" (406.4 cm)\*

\* Depending on tire size.

### To Adjust Tread Width

**⚠ WARNING**

Ensure the solution tanks are empty and the booms are cradled before adjusting manual tread width. Failure to comply may result in injury or death.

**⚠ CAUTION**

Ensure the machine is on level ground where there are no ditches or valleys to interfere when adjusting tread width.

**NOTICE**

Adjusting manual tread width requires use of specific tools and equipment. Contact your local John Deere dealer for assistance if you do not have the proper equipment to perform this procedure safely.



Tread Adjust Slide Path  
(Located on each leg)  
-Typical View

1. Ensure the solution tanks are empty and the booms are cradled.
2. Park the machine on a hard level surface.
3. Shut the engine OFF.
4. Engage the parking brake.
5. Ensure the Tread Adjust Slide Path (located on each leg) has an adequately lubricated surface to slide along during adjustment.

*NOTE: Refer to “Service - Lubrication” provided in the Maintenance and Storage Section elsewhere in this manual for further information.*

6. Loosen the front and rear Tread Adjust Bearing Bolts (located on each leg) **on one side of the machine only.**

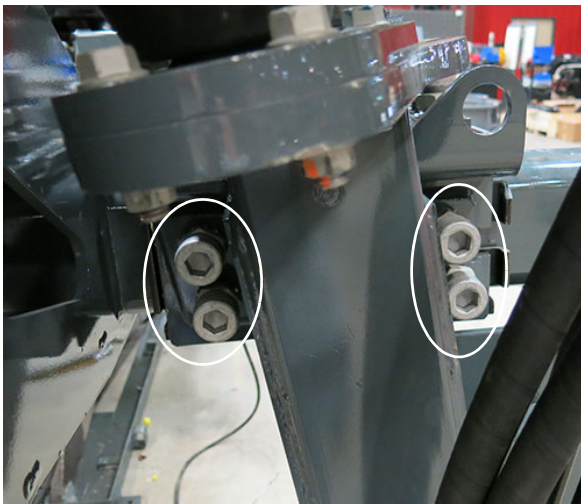

Tread Adjust Bearing Bolts - Top/Side  
(Located on each leg)  
-Typical View

7. Install a suitable prop item (i.e. steel tube) beneath each front and rear air bag mounting plate (**on the side of machine in which tread is being adjusted**) to prevent the suspension from extending, as shown in the following photo.



Steel Tube Installed Beneath  
Air Bag Mounting Plate  
-Typical View

8. Push sleeve around black tube on the Air Bag Connection Hose (located on top of each air bag - **on the side of machine in which tread is being adjusted**) IN and pull hose out to deflate air bags.

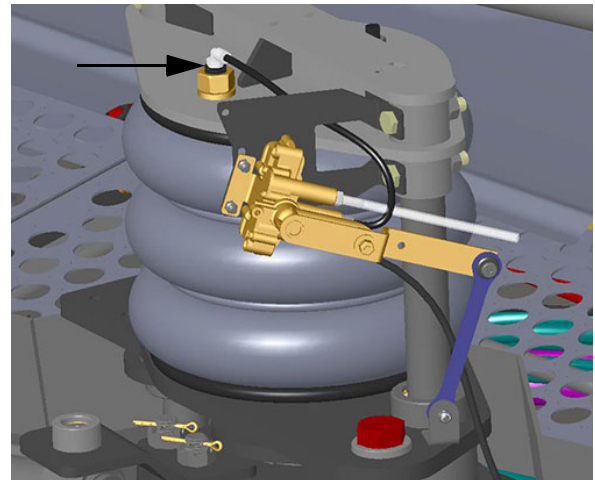

Air Bag Connection Hose  
(Located on top of air bag)  
-Typical View

9. Raise the machine until the tires (**on the side of machine in which tread is being adjusted**) are just off the ground.

## SECTION 9 – MISCELLANEOUS



*NOTE: Refer to “Lifting Your Machine” provided elsewhere in this section for further information.*

10. Loosen the lock nut on the end of each front and rear Tread Adjust Turnbuckle Rod (located between the frame and leg - **on the side of machine in which tread is being adjusted**). Rotate the front and rear turnbuckles to move tread in or out as desired.

*NOTE: Adjust tread width on both legs in small increments. Binding may occur if larger adjustments are made all at once, especially if adjusting one leg at a time.*

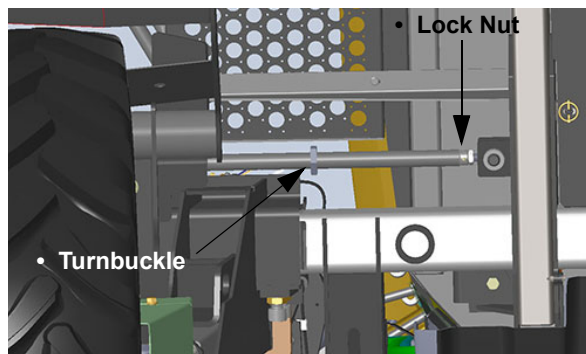

Tread Adjust Turnbuckle Rod  
(Located between the frame and leg)  
-Typical View

11. Observe the corresponding Tread Adjust Indicator (located on slide path).



Tread Adjust Indicator  
(Located on slide path)  
-Typical View

12. Re-tighten the front and rear Tread Adjust Bearing Bolts.
13. Re-tighten lock nut on the front and rear Tread Adjust Turnbuckle Rods.
14. Carefully lower machine to ground.
15. Repeat procedure to adjust tread width on opposite side of machine.

*NOTE: All four tread adjust indicators should have identical readings after tread adjustment is complete.*

## TALL CROP PACKAGE - INSTALLATION

### - If Equipped

*NOTE: Ensure correct Belly Shield configuration before installing.*

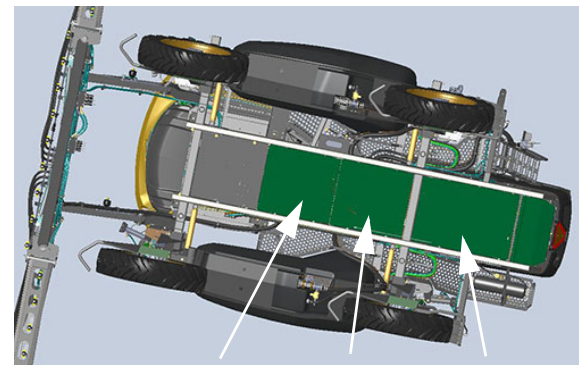

• Panel 1 • Panel 2 • Panel 3

Belly Shield Installation  
-Typical View

*\* View shown from bottom side of machine*

*NOTE: Two persons are required when installing the Tall Crop Package.*

### Installing Belly Shields

1. Install Securement Pin Assembly (Hanger Pin and Securement Pin) onto each Retaining Bracket (located along frame).

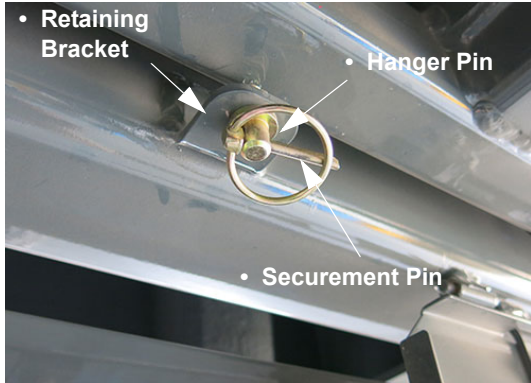

Retaining Bracket/  
Securement Pin Assembly  
-Typical View

2. Starting with Panel 1, install Support Hook Assemblies into the corresponding Hinge Bushings (located along frame).
3. Install Cotter Pin onto the end of each support hook.

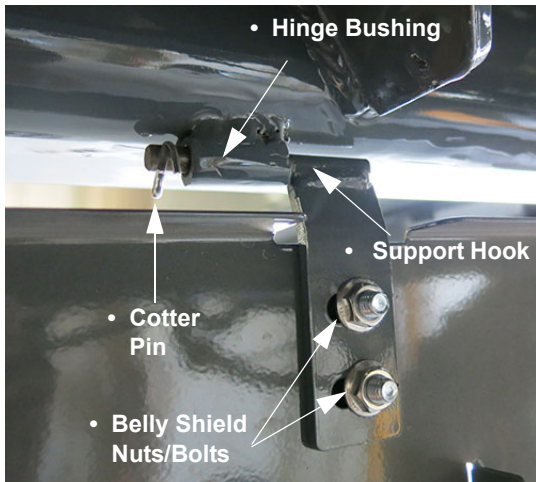

-Typical View

**NOTE:** Ensure belly shield nuts and bolts are loose.

4. On opposite side of machine, remove previously installed Securement Pins (from Hanger Pins).
5. Lift panel and align hole openings with Hanger Pins. Attach by reinstalling the Securement Pins.



Securement Pin  
(Installed into Hanger Pin)  
-Typical View

6. Using a 1/2" wrench or socket, tighten the belly shield nuts and bolts, as shown.



-Typical View

7. Repeat previous steps to install Panels 2 and 3.

## Assemble/Install Rear Brush Curtain

*NOTE: Ensure Curtain Mounting Bracket bend is facing UP, as shown in the following photo.*

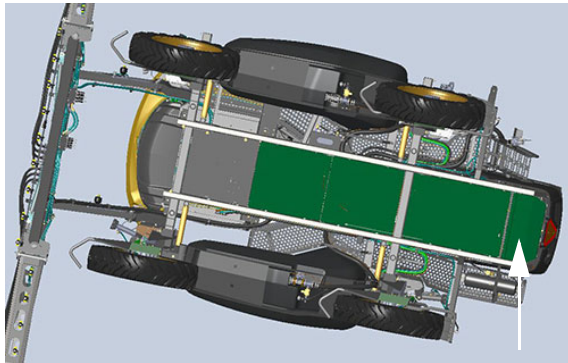

Rear Brush Curtain  
-Typical View

*\* View shown from bottom side of machine*

8. Place Curtain Mounting Bracket (bend side up) beneath edge of Brush Curtain, aligning the pre-drilled holes on each.
9. Arrange Curtain Support Strips along the edge of Brush Curtain, aligning the pre-drilled holes.

*NOTE: Ensure the notches of each Curtain Support Strip are facing inward (where they will later be adjoined together).*

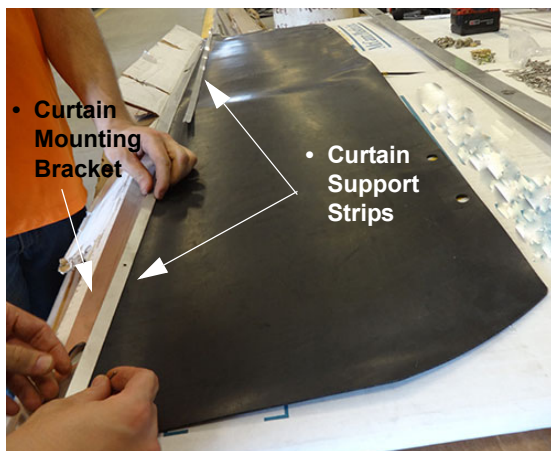

-Typical View

10. Starting at the end of the assembly, insert a 1/8" stainless steel rivet through the top of Curtain Support Strip, Brush Curtain, and Curtain Mounting Bracket.



Brush Curtain Assembly  
-Typical View

11. Use a rivet gun to secure.

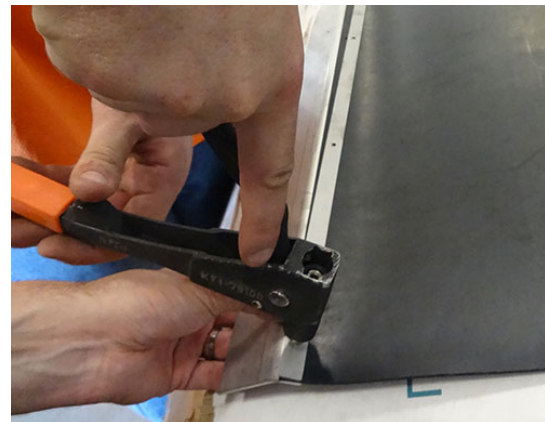

-Typical View

12. Repeat process to secure the remainder of the assembly, ensuring that the notches of Curtain Support Strips adjoin together.
13. Install assembled Brush Curtain onto Hanger Pins (located on the rear cross tube).
14. Install Securement Pins into each of the Hanger Pins.

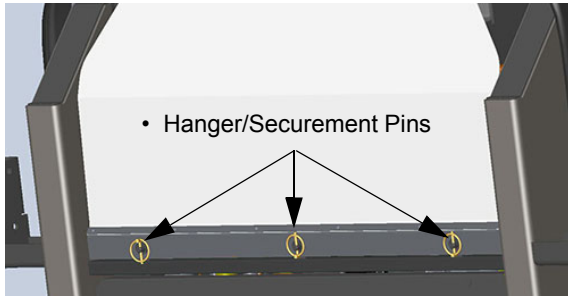

Brush Curtain Mounted to Rear Cross Tube  
-Typical View

15. Raise Brush Curtain and position the edge of curtain on top of the Hood Pivot Tube.
16. Align Brush Curtain and Hood Pivot Tube holes and install the four (4) Brush Curtain Mounting Bolts.
17. Install a 5/16-18" nut to the bottom of each bolt and hand-tighten.

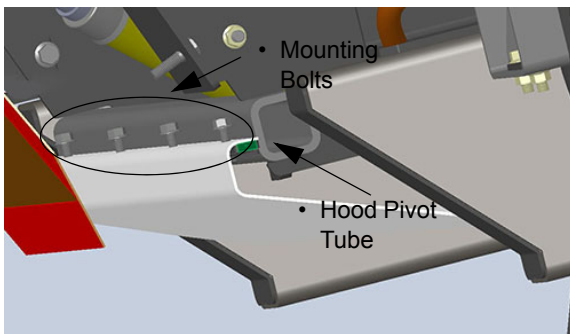

Brush Curtain Mounted to Hood Pivot Tube  
-Typical View

18. Using a 1/2" wrench, tighten Brush Curtain Mounting Bolts to 8 ft.-lbs.



Brush Curtain Installation  
-Typical View

### Installing Crop Dividers

1. Align the holes of the crop divider mounting plate assembly with the holes located on the inside lower leg assembly.
2. Install three (3) 1/2" x 1 3/4" serrated flange bolts into each of the hole openings with the pre-installed 3/4" weld nuts.

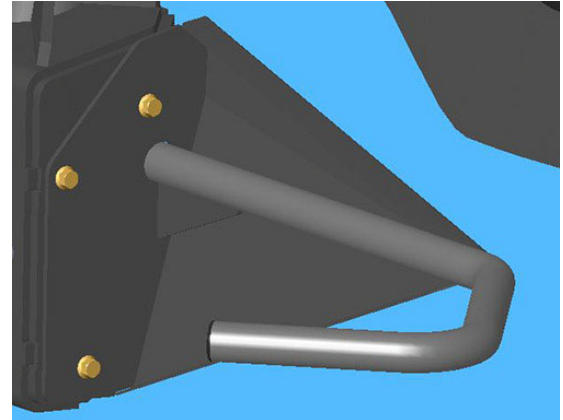

Crop Divider Assembly  
-Typical View

3. Tighten using a 3/4" wrench.

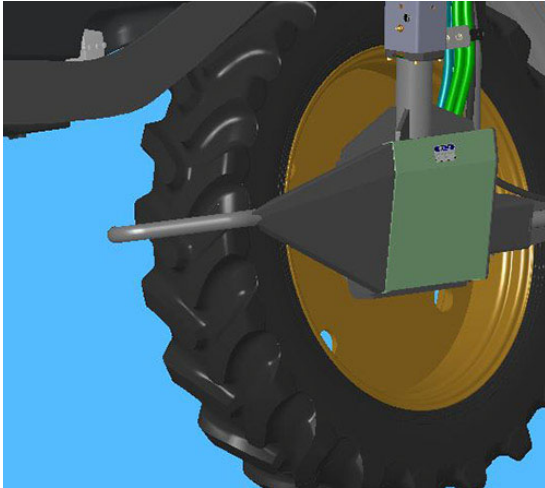

Crop Divider Installation  
-Typical View

4. Repeat steps to install remaining Crop Dividers.

### Installing Wheel Covers

#### **NOTICE**

Remove two (2) lug nuts at a time from the wheel bolts when installing the hub cap adapter plates.

1. Remove two (2) lug nuts from two (2) of the wheel bolts and set aside.
2. Install Hub Cap Adapter Plate onto the two bolts, as shown in the following photo.
3. Reinstall the two lug nuts onto bolts and using a 15/16" socket, re-torque to 185 ft.-lbs.  
Refer to "Service - Bolt Torque" provided in the *Maintenance and Storage Section* elsewhere in this manual for further information.

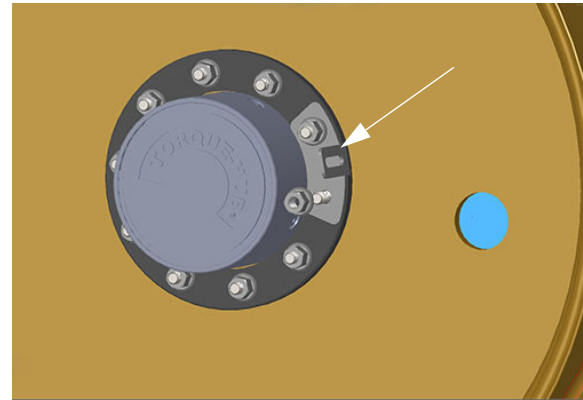

Hub Cap Adapter Plate  
-Typical View

4. Perform Steps 1-3 to install remaining adapter plates, ensuring only two (2) lug nuts are removed from the wheel bolts at one time.

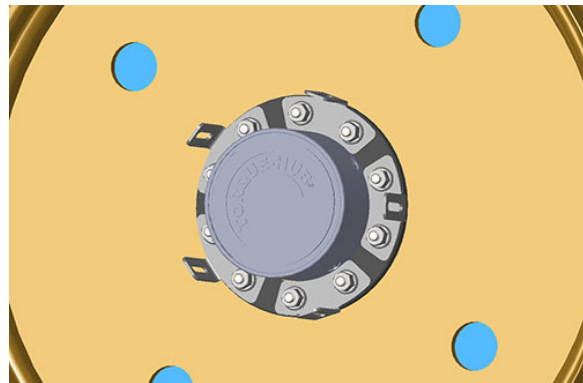

-Typical View

5. Install the Hub Cap Adapter Weldment onto the outside of the previously installed Hub Cap Adapter Plates.

*NOTE: Ensure the Hub Cap Adapter Weldment is flush with the face of the wheel hub.*



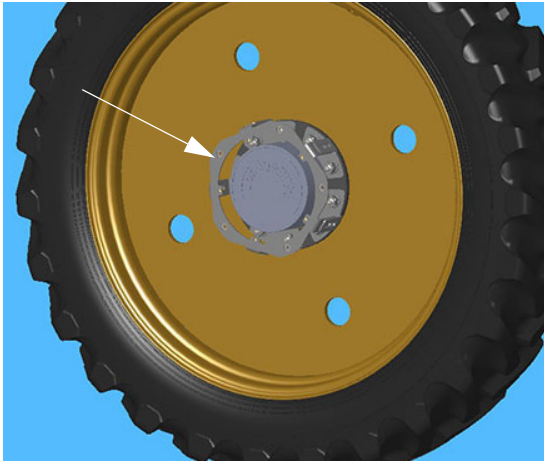

Hub Cap Adapter Weldment  
-Typical View



-Typical View

6. Install 1/2" bolt through the hub cap adapter assembly. Install nut to bolt and tighten with a 3/4" wrench.

*NOTE: Repeat for each adapter assembly location around the wheel hub.*

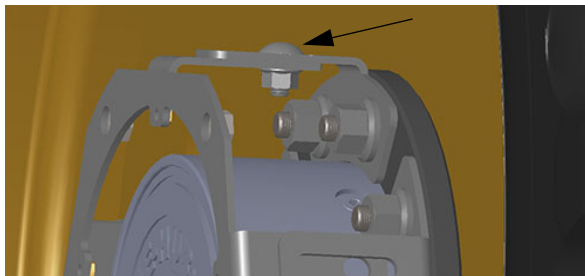

Hub Cap Adapter Bolt Installation  
-Typical View

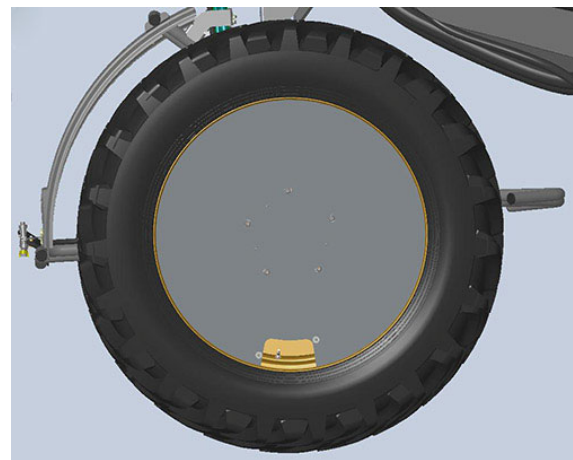

-Typical View

7. Install Wheel Cover onto the hub cap adapter assembly.

*NOTE: Ensure the rectangular cut-out on the wheel cover is aligned with the tire valve stem, as shown.*

8. Install 1/2" mounting bolt through the front of wheel cover into the Hub Cap Adapter Weldment weld nuts.



Wheel Cover Mounting Bolt Installation  
-Typical View

## SECTION 9 – MISCELLANEOUS



9. Tighten with a 5/16" hex wrench.

*NOTE: Repeat for each adapter assembly location around the wheel hub.*

10. Install Valve Stem Access Panel to the Wheel Cover.
11. With the hole openings aligned, install a 1/4" bolt (tighten with 5/32" Allen wrench) and nut (tighten with 7/16" wrench) into the upper left holes.
12. Install a 1/4" bolt through the lower right hole in the access panel and tighten with a 5/32" Allen wrench.



Valve Stem Access Panel  
-Typical View

13. Install Hub Cap Access Panel to center of wheel cover, ensuring the hole openings of each are properly aligned.

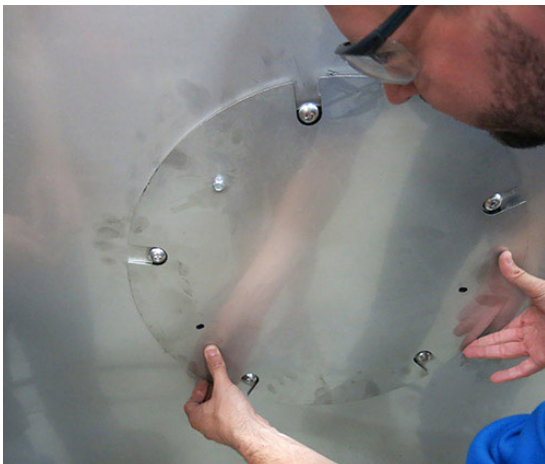

Hub Cap Access Panel  
-Typical View

14. Install 1/4" bolt through access panel and wheel cover, tightening with a 5/32" Allen wrench.
15. Wheel cover installation complete.

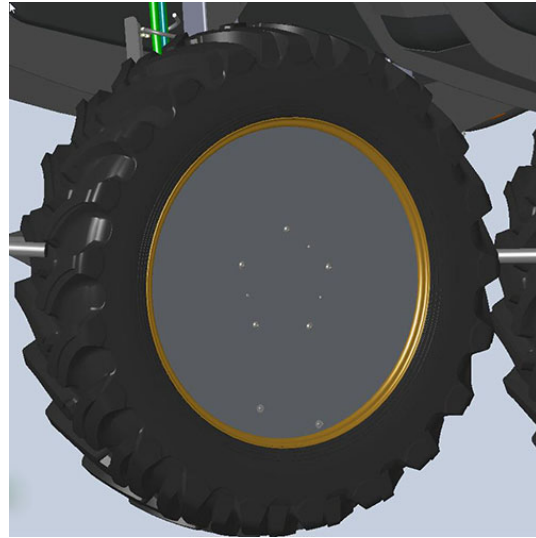

Wheel Cover Installation  
-Typical View

**TROUBLESHOOTING**

<b>Problem</b>	<b>Possible Cause</b>	<b>Suggested Remedy</b>
Engine will not crank	<ul style="list-style-type: none"> <li>• Dead battery</li> <li>• Poor battery connections</li> <li>• Starter or starter relay</li> <li>• Blown fuse in engine electric box</li> <li>• Battery Disconnect Switch in the OFF position</li> <li>• Parking brake not engaged</li> </ul>	<ul style="list-style-type: none"> <li>• Recharge or replace battery</li> <li>• Clean and tighten connections</li> <li>• Test (rebuild or replace)</li> <li>• Check/replace fuse</li> <li>• Turn Battery Disconnect Switch to the ON position</li> <li>• Engage parking brake</li> </ul>
Engine will not start	<ul style="list-style-type: none"> <li>• Fuel tank empty</li> <li>• Clogged fuel filter(s)</li> <li>• Cold weather</li> <li>• E-Stop Switch is engaged</li> <li>• Low starter speed</li> <li>• Blown fuse in engine box</li> </ul>	<ul style="list-style-type: none"> <li>• Fill fuel tank</li> <li>• Replace fuel filter(s)</li> <li>• Refer to the engine manufacturer's operation manual for cold weather starting</li> <li>• Disengage E-Stop Switch</li> <li>• Check starter and battery</li> <li>• Check/replace fuse</li> </ul>
Engine overheats	<ul style="list-style-type: none"> <li>• Engine overload</li> <li>• Dirty radiator core/grille screen</li> <li>• Faulty radiator cap</li> <li>• Fan malfunction</li> <li>• Faulty thermostat</li> <li>• Low coolant level</li> </ul>	<ul style="list-style-type: none"> <li>• Reduce load</li> <li>• Remove foreign material and clean all items</li> <li>• Replace radiator cap</li> <li>• Check fan speed</li> <li>• Replace thermostat</li> <li>• Refill to proper level</li> </ul>
Engine misfires (runs uneven/low power)	<ul style="list-style-type: none"> <li>• Water in fuel</li> <li>• Dirty air cleaner element</li> <li>• Poor grade of fuel</li> <li>• Fuel tank vent clogged</li> <li>• Clogged fuel filter(s)</li> </ul>	<ul style="list-style-type: none"> <li>• Drain, flush, replace filter, fill system</li> <li>• Replace air cleaner element</li> <li>• Drain system, change to a higher fuel grade</li> <li>• Open fuel tank vent (in cap)</li> <li>• Replace fuel filter(s)</li> </ul>
Engine knocks	<ul style="list-style-type: none"> <li>• Low oil level in crankcase</li> <li>• Cold engine</li> </ul>	<ul style="list-style-type: none"> <li>• Add oil to full mark</li> <li>• Allow proper warm-up period, refer to engine manufacturer's operation manual</li> </ul>
Solution Pump will not prime	<ul style="list-style-type: none"> <li>• Low water level in pump</li> <li>• Clogged/kinked vent line or vent check valve</li> <li>• Air leak in suction line</li> <li>• Solution tank valve closed</li> </ul>	<ul style="list-style-type: none"> <li>• Ensure solution tanks are not empty</li> <li>• Inspect vent line or vent check valve for blockage/kinking</li> <li>• Inspect and tighten all fittings in suction line</li> <li>• Open solution tank valve, allow air to leave the system</li> </ul>

## SECTION 9 – MISCELLANEOUS



Erratic reading on pressure gauge	<ul style="list-style-type: none"> <li>• Orifice in back of gauge clogged</li> <li>• Faulty gauge</li> <li>• Air leak in suction line</li> <li>• Solution strainer plugged</li> <li>• Glycerin leaking from pressure gauge</li> </ul>	<ul style="list-style-type: none"> <li>• Remove gauge, clean orifice, reinstall</li> <li>• Replace gauge</li> <li>• Inspect and tighten all fittings in suction line</li> <li>• Check solution strainer</li> <li>• Replace gauge</li> </ul>
Electric solution valve malfunction	<ul style="list-style-type: none"> <li>• Faulty ground</li> <li>• Dirty contact terminals</li> <li>• Separation in wire</li> <li>• Faulty switch</li> <li>• Bad valve</li> </ul>	<ul style="list-style-type: none"> <li>• Clean and tighten ground</li> <li>• Clean contact terminals</li> <li>• Check continuity and replace wire</li> <li>• Replace switch</li> <li>• Replace valve</li> </ul>
Solution pump not producing adequate pressure	<ul style="list-style-type: none"> <li>• Clogged line strainer screen</li> <li>• Air leak in suction flow to pump</li> <li>• Restricted solution flow to pump</li> <li>• Suction hose collapsed</li> <li>• Hydraulic failure</li> </ul>	<ul style="list-style-type: none"> <li>• Remove screen, clean thoroughly, tighten strainer cap to avoid air leak</li> <li>• Inspect and tighten all fittings on suction line</li> <li>• Ensure Main Tank Valve is completely open</li> <li>• Obstruction at inlet end of hose causing high vacuum on hose</li> <li>• Contact your local John Deere dealer for assistance</li> </ul>
Machine will not move in either direction	<ul style="list-style-type: none"> <li>• Engine speed too low</li> <li>• Oil level in hydraulic reservoir too low</li> <li>• Clogged pressure filter</li> <li>• Hydrostatic System failure</li> </ul>	<ul style="list-style-type: none"> <li>• Set engine at operating RPM</li> <li>• Fill hydraulic reservoir to proper level with approved oil</li> <li>• Replace pressure filter</li> <li>• Contact your local John Deere dealer for assistance</li> </ul>
Machine will move in only one direction	<ul style="list-style-type: none"> <li>• Hydrostatic System failure</li> </ul>	<ul style="list-style-type: none"> <li>• Contact your local John Deere dealer for assistance</li> </ul>
Hydrostatic system responding slowly	<ul style="list-style-type: none"> <li>• Engine speed too low</li> <li>• Oil in hydraulic reservoir low</li> <li>• Cold oil</li> <li>• Plugged filter</li> <li>• Partially restricted suction line</li> <li>• Hydrostatic System failure</li> </ul>	<ul style="list-style-type: none"> <li>• Set engine at operating RPM</li> <li>• Fill hydraulic reservoir to proper level with approved oil</li> <li>• Allow adequate warm-up period</li> <li>• Check and replace filter</li> <li>• Inspect for collapsed suction hose</li> <li>• Contact your local John Deere dealer for assistance</li> </ul>
Noisy hydrostatic system	<ul style="list-style-type: none"> <li>• Cold oil</li> <li>• Low engine speed</li> <li>• Oil level in hydraulic reservoir low</li> <li>• Hydrostatic System failure</li> </ul>	<ul style="list-style-type: none"> <li>• Allow adequate warm-up period</li> <li>• Increase engine speed</li> <li>• Fill hydraulic reservoir to proper level with approved oil</li> <li>• Contact your local John Deere dealer for assistance</li> </ul>



## SECTION 9 – MISCELLANEOUS

Entire hydraulic system fails to function	<ul style="list-style-type: none"> <li>• Oil level in hydraulic reservoir too low</li> <li>• Auxiliary hydraulic system failure</li> </ul>	<ul style="list-style-type: none"> <li>• Fill hydraulic reservoir to proper level with approved oil</li> <li>• Contact your local John Deere dealer for assistance</li> </ul>
Noisy hydraulic pump	<ul style="list-style-type: none"> <li>• Oil level in hydraulic reservoir too low</li> <li>• Auxiliary hydraulic system failure</li> </ul>	<ul style="list-style-type: none"> <li>• Fill hydraulic reservoir to proper level with approved oil</li> <li>• Contact your local John Deere dealer for assistance</li> </ul>
AWS System will not turn on	<ul style="list-style-type: none"> <li>• AWS Button (located on the Machine Display) is OFF</li> <li>• Machine not in Field Mode</li> <li>• Sensor or valve malfunction</li> </ul>	<ul style="list-style-type: none"> <li>• Turn AWS Button ON</li> <li>• Change machine's drive state to Field Mode</li> <li>• Contact your local John Deere dealer for assistance</li> </ul>
AWS System is ON, but rear tires do not follow behind the front tires	<ul style="list-style-type: none"> <li>• Machine speed is greater than AWS shutoff speed</li> <li>• Sensor or valve malfunction</li> </ul>	<ul style="list-style-type: none"> <li>• This is left up to the operator's discretion</li> <li>• Contact your local John Deere dealer for assistance</li> </ul>
AWS System inoperable, machine will only move at slow speed	<ul style="list-style-type: none"> <li>• Sensor malfunction</li> </ul>	<ul style="list-style-type: none"> <li>• Move the Hydrostatic Drive Control Handle to NEUTRAL, wait for the "FAULT" drive state to disappear on the Machine Display, and restart machine</li> </ul> <p><i>NOTE: In Road mode, the rear tires are locked until the machine is put into Field mode.</i></p>
Entire electrical system is dead	<ul style="list-style-type: none"> <li>• Dead battery</li> <li>• Poor battery connection</li> <li>• Low charge rate</li> <li>• No charge rate</li> <li>• Battery Disconnect Switch is in the OFF position</li> </ul>	<ul style="list-style-type: none"> <li>• Replace battery</li> <li>• Clean and tighten battery connections</li> <li>• Tighten alternator belt</li> <li>• Replace alternator</li> <li>• Turn Battery Disconnect Switch to the ON position</li> </ul>
Light system does not function	<ul style="list-style-type: none"> <li>• Poor ground</li> <li>• Burned out bulb</li> <li>• Separation or short in wire</li> <li>• Blown fuse</li> <li>• Faulty switch</li> <li>• Ignition switch is OFF</li> </ul>	<ul style="list-style-type: none"> <li>• Clean and tighten ground</li> <li>• Replace bulb</li> <li>• Check continuity and replace wire</li> <li>• Replace fuse</li> <li>• Replace switch</li> <li>• Turn ignition switch ON</li> </ul>



A Word From Hagie Manufacturing	
Company .....	1-1
About This Manual .....	1-1
Air Suspension Exhaust .....	9-7
All-Wheel Steer (AWS) .....	4-15
Application .....	7-59
Batteries .....	6-1
Battery Disconnect Switch .....	6-2
Draining Your Solution Tanks .....	7-33
Eductor System .....	7-45
Electric Hood .....	9-11
Emergency Exit .....	2-8
Emergency Stop .....	2-7
Engine - Starting .....	4-1
Engine Aftertreatment - Final Tier 4 .....	4-3
Fence Row Applicator .....	7-29
Filling Your Solution Tanks .....	7-30
Fire Extinguisher .....	2-9
Foam Marker System .....	7-42
Front End Access .....	9-12
Fuse and Relay Ratings .....	6-8
Fuses and Relays .....	6-4
Hand Wash System .....	9-9
Hydraulic System Components .....	5-1
Hydrostatic Drive .....	4-10
Identification .....	1-3
Intended Use .....	2-1
Ladder .....	5-9
Lifting Your Machine .....	9-5
Machine Display .....	3-32
Modular Injection System .....	7-49
Operator's Station .....	3-7
Pressure Washer .....	5-10
Product Warranty .....	1-3
Reversible Fan - Variable Pitch .....	5-4
Rinse System .....	7-34
Rotating Beacon .....	2-7
Safety Decals .....	2-9
Safety Messages Used In This	
Manual .....	1-2
Safety Precautions .....	2-1
Seat - Instructor .....	3-7
Seat - Operator (Premium) .....	3-4
Seat - Operator (Standard) .....	3-1
Seat Belt .....	2-7
Service - Bolt Torque .....	8-24
Service - Engine Drive Belt .....	8-24
Service - Filters .....	8-11
Service - Fluids .....	8-1
Service - Lubrication .....	8-22
Service - Miscellaneous .....	8-29
Service - Toe-In .....	8-27
Service and Assistance .....	1-2
Service Intervals .....	8-34
Solution Pump Re-Priming .....	7-38
Solution System - Operation .....	7-25
Solution System Components .....	7-16
Sound Level .....	1-4
Specifications .....	1-6
Spray Boom - Rear .....	7-14
Spray Booms .....	7-1
Storage .....	8-36
Tall Crop Package - Installation .....	9-16
Torque Values .....	1-17
TOWING .....	9-3
Transporting .....	9-1
Tread Adjustment - Hydraulic .....	5-6
Tread Adjustment - Manual .....	9-13
Troubleshooting .....	9-23
Viscous Clutch Fan .....	9-8
Whole Body Vibration .....	1-4

# NOTES

---

# NOTES

---



# NOTES

---