

CALIFORNIA

Proposition 65

WARNING: Diesel engine exhaust and some of its constituents are known to the State of California to cause cancer and birth defects or other reproductive harm.

WARNING: Battery posts, terminals, and related accessories contain lead and lead compounds, chemicals known to the State of California to cause cancer and birth defects or other reproductive harm.



ANY PICTURES CONTAINED WITHIN THIS OPERATOR'S MANUAL THAT DEPICT SITUATIONS WITH SHIELDS, GUARDS, RAILS, OR LIDS REMOVED ARE FOR DEMONSTRATION PURPOSES ONLY. HAGIE MANUFACTURING COMPANY STRONGLY URGES THE OPERATOR TO KEEP ALL SHIELDS AND SAFETY DEVICES IN PLACE AT ALL TIMES.



**OPERATOR'S MANUAL
FOR
HAGIE MODEL DTS 10 HI-TRACTOR**

HAGIE MANUFACTURING COMPANY

721 CENTRAL AVENUE WEST
BOX 273
CLARION, IOWA 50525-0273

(515) 532-2861

COVERS MACHINE SERIAL NUMBERS: U1411331001 thru U1411331200

© 2012 Hagie Manufacturing Company. Clarion, Iowa USA

10-12 493567

ABBREVIATIONS

A/C	AIR CONDITIONING	M/F	MAINFRAME
ACCUM	ACCUMULATOR	MPH	MILES PER HOUR
ADJ	ADJUST	MT	MOUNT
ADPTR	ADAPTER	MTH	MONTH
AGI	AGITATOR	MTR	MOTOR
ALT	ALTERNATOR	NO	NUMBER
AMP	AMPERE	OD	OUTSIDE DIAMETER
APPROX	APPROXIMATELY	PLT	PLATE
ASSY	ASSEMBLY	POLY	POLYETHYLENE
AUX	AUXILIARY	PRESS	PRESSURE
BRKT	BRACKET	PRKNG	PARKING
BTRY	BATTERY	PSI	POUNDS PER SQUARE INCH
C	CELSIUS	QT	QUART
CAL	CALIBRATION	RAD	RADIATOR
CCA	COLD CRANKING AMPS	REC	RECOMMENDED
CHEM	CHEMICAL	REQ	REQUIRED
CYL	CYLINDER	RPM	REVOLUTIONS PER MINUTE
DIA	DIAGRAM	SEC	SECOND
DISPL	DISPLACEMENT	SERV	SERVICE
EA	EACH	SLCTR	SELECTOR
ELECT	ELECTRIC	SMV	SLOW MOVING VEHICLE
F	FAHRENHEIT	SOLE	SOLENOID
FIG	FIGURE	SOLU	SOLUTION
FLO	FLOW	SPCNG	SPACING
FRT	FRONT	SPEC	SPECIFICATION
FT	FOOT OR FEET	STRG	STEERING
GA	GAUGE	SQ	SQUARE
GAL	GALLON	TACH	TACHOMETER
GPA	GALLONS PER ACRE	TEMP	TEMPERATURE
GPM	GALLONS PER MINUTE	TERM	TERMINAL
GPS	GLOBAL POSITIONING SATELLITE	TRD	TREAD
HAL	HALOGEN	TT	TUBE-TYPE
HR	HOOR	TU	TUBELESS
HYD	HYDRAULIC	VAR	VARIABLE
HYDRO	HYDROSTATIC	V	VOLT
ID	INSIDE DIAMETER	VFC	VARIABLE FLOW CONTROL
IN	INCH	VLV	VALVE
INFO	INFORMATION	W/	WITH
Km/H	KILOMETERS PER HOUR	W/O	WITHOUT
LB	POUND	W	WEIGHT
MAINT	MAINTENANCE	WD	WHEEL DRIVE
MIN	MINUTE	WHL	WHEEL

TO THE OWNER



A WORD FROM HAGIE MANUFACTURING COMPANY

Congratulations on your selection of a Hagie Model DTS 10 sprayer. We recommend that you study this Operator's Manual and become acquainted with the adjustments and operating procedures before attempting to operate your new sprayer. As with any piece of equipment, certain operating procedures, service, and maintenance are required to keep it in top running condition.

We have attempted herein to cover all of the adjustments required to fit varying conditions. However, there may be times when special care must be considered.

Hagie Manufacturing Company reserves the right to make changes in the design and material of any subsequent sprayer without obligation to existing units.

We thank you for choosing a Hagie sprayer and assure you of our continued interest in its satisfactory operation for you. If we might be of assistance to you, please call us.

We are proud to have you as a customer.

CAUTION

READ OPERATOR'S MANUAL. BE ALERT. LEARN TO OPERATE THIS MACHINE SAFELY. OBSERVE ALL SAFETY PRACTICES. MACHINES CAN BE HAZARDOUS IN THE HANDS OF AN UNFAMILIAR, UNTRAINED, OR COMPLACENT OPERATOR. SHUT OFF ENGINE BEFORE SERVICING. WHEN MECHANISM BECOMES CLOGGED, SHUT OFF ENGINE BEFORE CLEANING. DON'T RISK INJURY OR DEATH.

650852

TO THE OPERATOR

The following pages and illustrations will help you operate and service your new sprayer. It is the responsibility of the user to read the Operator's Manual and comply with the safe correct operating procedures and lubricate and maintain the product according to the maintenance schedule.

The user is responsible for inspecting the machine and having parts repaired or replaced when continued use of the product causes damage or excessive wear to other parts.

Keep this manual in a convenient place for easy reference when problems arise. This manual is considered a permanent fixture with this machine. In the event of resale, this manual should accompany the sprayer. If you do not understand any part of the manual or require additional information or service, contact the Hagie Customer Support Department:

Hagie Manufacturing Company
Box 273, Clarion, IA 50525
(515) 532-2861

The following symbols, found throughout this manual, alert you to potentially dangerous conditions to the operator, service personnel, or the equipment.



This symbol indicates an immanently hazardous situation which, if not avoided, will result in death or serious injury.



This symbol indicates a potentially hazardous situation which, if not avoided, could result in death or injury.



This symbol indicates a potentially hazardous situation which, if not avoided, may result in minor or moderate injury. It may also be used to alert against unsafe practices.

TABLE OF CONTENTS

I.	SAFETY/DECALS.....	4-16
II.	SPRAYER IDENTIFICATION.....	17-18
III.	SPECIFICATIONS.....	19-24
IV.	PREPARING TO OPERATE.....	25-30
V.	OPERATING INFORMATION.....	31-74
VI.	CALIBRATION.....	75-76
VII.	TRANSPORTING.....	77-79
VIII.	SERVICE AND MAINTENANCE.....	80-112
IX.	STORAGE.....	113-114
X.	TROUBLE SHOOTING.....	115-122
XI.	LIMITED WARRANTY.....	123
	INDEX.....	124

I. SAFETY/DECALS

SAFETY PRECAUTIONS

Most accidents occur as the result of failure to follow simple and fundamental safety rules. For this reason, most accidents can be prevented by recognizing the real cause and doing something about it before the accident occurs.

Many conditions cannot be completely safeguarded against without interfering with efficient operation and/or reasonable accessibility. Therefore, you must study this Operator's Manual and learn how to use the sprayer controls for safe operation. Likewise, do not let anyone operate without instruction.

Do NOT make modifications such as weldments, add-ons, adaptations, or changes from the original design of sprayer. Such changes and/or modifications may become safety hazards to you and to others and **will void all warranties**.



Replace missing, faded, or damaged safety signs. See the operator's manual for correct sign and placement.

Do Not By-Pass Safety Start Switch

Start the machine from the operator's seat only. The machine must be in neutral to start.

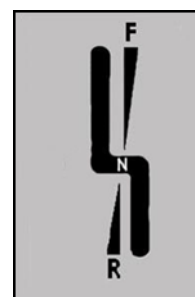

Use Caution While Driving

- Never drive too close to ditches, embankments, holes, mounds or other obstacles.
- Never drive on hills too steep for safe operation.
- Reduce the sprayer speed while turning.
- Do not permit passengers on machine when it is moving; they may fall off or obstruct the operator's view.
- Check overhead clearance before driving under any overhead obstructions. Contact with power lines can result in serious injury or death.
- Booms must be folded and in cradles when driving.



I. SAFETY/DECALS

Keep Riders off Machine

- Do not permit passengers to ride on the machine or in the cab. The only time passengers should be permitted is for instructional or diagnostic purposes. The passenger should be seated on the buddy seat next to the operator and never allowed to ride outside of the cab.



Remove Paint before Welding or Heating

- Avoid potentially toxic fumes and dust. Hazardous fumes can be generated when paint is heated by welding, soldering, or using a torch.
- Do not use chlorinated solvents in areas where welding will take place.
- Do all work in an area that is well ventilated to carry toxic fumes and dust away
- Dispose of paint and solvents properly.



Avoid Heating near Pressurized Lines

- Avoid torching, welding, and soldering near pressurized hydraulic lines. Pressurized lines may accidentally burst when heat goes beyond the immediate flame area.



Handle Fuel Safely– Avoid Fires

- Always turn engine off and allow it to cool before re-fueling.
- NEVER smoke while re-fueling.
- Do not fill tank completely, fuel may expand and run over.
- Always clean up spilled fuel with soapy water.
- Keep a fire extinguisher close when re-fueling.

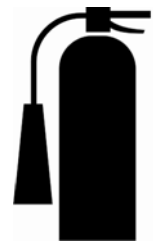

I. SAFETY/DECALS

Operate Safely

- Before moving sprayer, make sure there are no obstacles or persons in the path of travel.
- Never operate a machine in the same field as walking personnel.
- Always drive at a reasonable field speed.
- Never operate sprayer on roadway with any solution in the tank. Additional weight caused from partially full or full solution tanks may cause erratic or increased stopping distance.
- Never operate the sprayer at transport speeds with a full tank. The wheel motors and planetary gear hubs are not rated to withstand high speeds under full loads and may over heat or blow out.
- Make sure SMV and SIS emblem is in place and visible from rear when traveling on public roadways.
- Pull over to the side of the road before stopping.
- Always come to a complete stop before reversing directions.
- Keep a fire extinguisher close at all times.
- Keep ALL shields in place.
- Keep clear of all moving parts and keep others away when operating.
- Do not wear loose fitting clothing that may be blown or drawn into moving parts.
- Do not activate parking brake while machine is in motion.
- Stop slowly to avoid “nose diving”.
- Reduce speed for icy, wet, graveled or soft roadway surfaces.
- Use flashers/hazard warning lights, day or night, unless prohibited by law.
- Keep away from overhead power lines. Serious injury or death to you or others may result should the machine contact electrical wires.
- Never fold/unfold boom extension when main boom is in cradle.
- Never operate sprayer with one boom out of cradle and the other boom in cradle.
- Do not adjust factory engine RPM settings.
- Operate engine at two pumps to assure proper charge pressure for brakes to work properly.
- Never use starting fluid to assist engine start up.
- If equipped with ground speed sensing radar or light sensing depth units, do NOT look directly into radar beam. It emits a very low intensity microwave signal which may cause possible eye damage.



I. SAFETY/DECALS

Be Prepared

- Be prepared for an emergency. Keep a fire extinguisher handy, a first aid kit and clean water in the cab.
- Make sure to service the fire extinguisher regularly. Keep an accurate inventory of supplies in the first aid kit and dispose of anything that has expired.



Wear Protective Clothing

- Do not wear loose fitting clothes that could get caught in moving parts. Wear safety equipment that is appropriate for the job.
- Do not store chemical soaked clothes in the cab. Clean off as much mud and dirt from your shoes as you can before entering the cab.



Protect Against Noise

- Operating equipment safely requires the full attention of the operator. Do not wear radio or music headphones while operating the machine.
- Prolonged exposure to loud noise could cause loss of hearing. Wear suitable hearing protection.



Battery Acid Accident Prevention

- Avoid serious injury by avoiding battery acid contact with your body. Battery electrolyte contains sulfuric acid that is strong enough to eat holes in clothing and cause blindness if splashed into eyes.

Make sure to:

- Fill batteries in a well-ventilated area.
- Wear Personal Protective Equipment when servicing a battery.
- Avoid breathing in the fumes when recharging with electrolyte.
- Avoid spilling or dripping electrolyte.
- When charging a battery, connect positive cable to positive terminal and negative cable to negative terminal. Failure to do so may result in an explosion and cause injury.

I. SAFETY/DECALS

If you spill on yourself:

- Immediately begin flushing affected area with cold water while removing any contaminated clothing and shoes. Continue to flush the area for a minimum of 15 minutes.
- Call a physician.
- While transporting or waiting for medical attention, apply compresses of iced water or immerse affected area in iced water. Do not allow tissue to freeze.
- Do not apply creams or ointments until you have been seen by a physician.



If acid is swallowed:

- Do not induce vomiting.
- Drink large amounts of water.
- Get medical attention immediately!
- Do not neutralize the acid.



If fumes are inhaled:

- Move the person into fresh air.
- Do not give artificial respiration to a person that is able to breathe on their own.
- Give CPR only if there is no breathing AND no pulse.
- Seek medical attention IMMEDIATELY!

Handle Agricultural Chemicals Safely

Agricultural chemicals used in applications can be harmful to your health and the environment if not used carefully.

- Always follow the manufacturer's label directions for use.
- Never allow chemicals to come in contact with your skin or eyes.
- NEVER pour chemicals into an empty tank, fill tank half full of water first.
- Dispose of empty chemical containers properly.
- Wash spilled chemicals or spray residue from the sprayer to prevent corrosion and deterioration.



I. SAFETY/DECALS

- Select safe areas to fill, flush, calibrate, and clean sprayer where chemicals will not run off to contaminate people, animals, vegetation, or water supply.
- Never place a spray nozzle to your lips in an attempt to unclog it.
- Do not spray when wind is in excess of chemical manufacturer's recommendation.
- Store chemicals in their original containers with the label intact.
- Store chemicals in a separate, locked building.
- Wear protective equipment as recommended by chemical manufacturer.



Safe Hydraulic Maintenance

- Always practice personal safety when performing service or maintenance on the hydraulic system.
- Use caution when working with hydraulic fluid under pressure. Escaping fluid can have sufficient force to penetrate your skin causing serious injury. This fluid may also be hot enough to burn.
- Always lower the load or relieve the pressure before repairing a hydraulic oil leak.

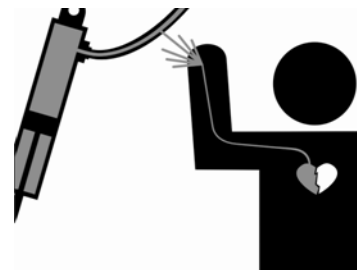

Beware of Exhaust Fumes

- Never run the machine in a closed building. Proper ventilation is required. Use an exhaust pipe extension to remove fumes if you must operate in a building. Also open doors and windows to bring in enough outside air into the area.



I. SAFETY/DECALS

General Maintenance Safety

- Turn off engine before checking, adjusting, repairing, lubricating, or cleaning any part of the sprayer.
- When servicing the radiator, let the engine cool before removing pressurized cap.
- Disconnect battery ground cable and turn main battery switch off before servicing electrical system or welding on machine.
- Each Hagie machine outfitted with AWS has position sensing internal to the steering cylinders. Please disconnect each sensor before welding on the machine. Then re-connect when done welding.



Operating Optional Components

Tread Width

- Select widest tread setting to fit between crop rows.
- Never manually adjust tread width on sprayer until wheels have been properly blocked. Loosen leg clamp bolts only enough for leg to slide on frame.
- If equipped with hydraulic tread adjust, never loosen leg mounting bolts to adjust bearing clearance. It is recommended to either add additional or remove shims to gain the proper clearance.



Sprayer Booms

- Cradle booms when leaving sprayer unattended.
- Make sure booms are folded when cradled.
- Select a safe area before folding/unfolding booms.
- Clear area of personnel.
- Check for overhead obstructions.
- Do not fold or unfold booms near power lines. Contact with power lines can result in serious injury or death.
- Do not fold/unfold boom extensions when main boom is in the cradle.
- Do not operate sprayer with one boom out of cradle and other boom in cradle.

I. SAFETY/DECALS

WARNING DECALS

Decals warning you of avoidable danger are located on various parts of the sprayer. They are there for your personal safety and protection. DO NOT remove them. They will fracture upon attempted removal and therefore must be replaced.

Following are locations of important safety decals. Replace them if they are torn or missing. All warning decals and other instructional Hagie decals or machine striping may be purchased through the Hagie Customer Support Department. To replace decals, be sure that the installation area is clean and dry; decide on exact position before you remove the backing paper.



DECAL LOCATION



650175

Inside rear cab window on left side.

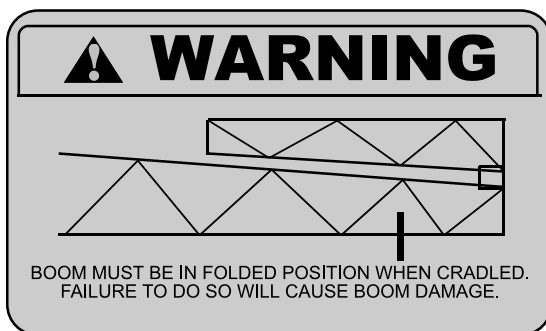
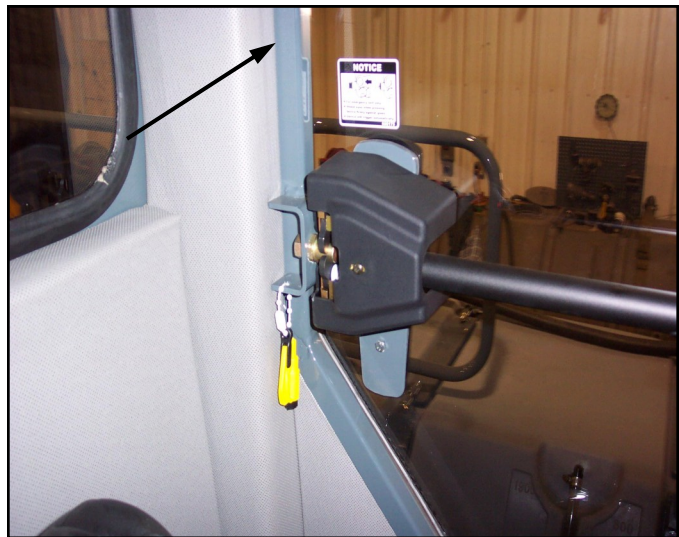

650336

Inside right-hand cab window to the rear.



I. SAFETY/DECALS

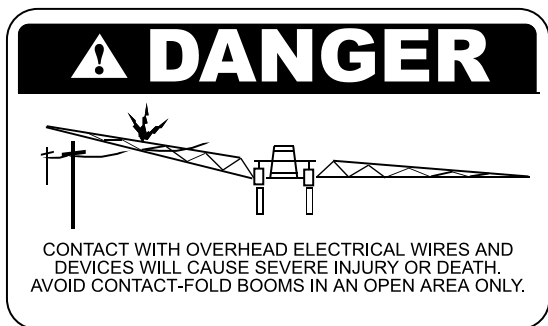

650337

Right-hand cab window.

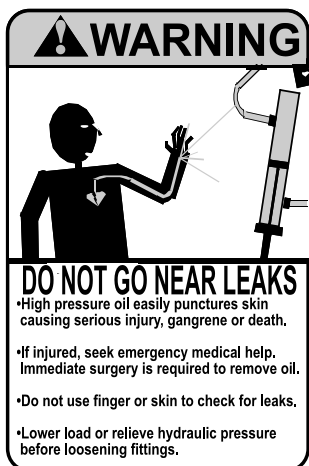

Steering column.

650339



650340

Near brake switch on switch panel in cab.



DECALS CONTINUED

I. SAFETY/DECALS

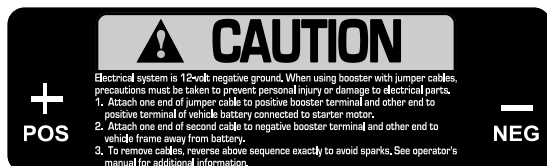

650350

Rear of mainframe above booster terminals.



650831

Steering column.



650847

Outside, left-hand, rear panel of cab



I. SAFETY/DECALS



650848

Rear of left-hand fuel tank.



650848

Rear of right-hand fuel tank.

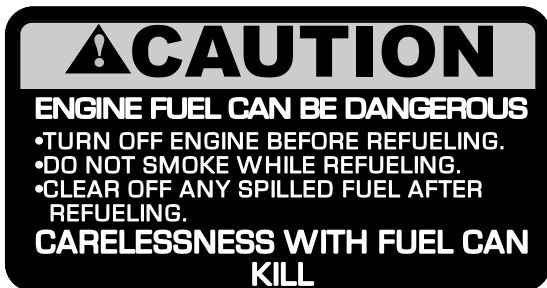

650849

Top of each fuel tank.



DECALS CONTINUED 

I. SAFETY/DECALS



650850

Top of each solution tank.



650851

Right rear mainframe.



650851

Left rear mainframe



I. SAFETY/DECALS



650852

Storage console lid in cab.

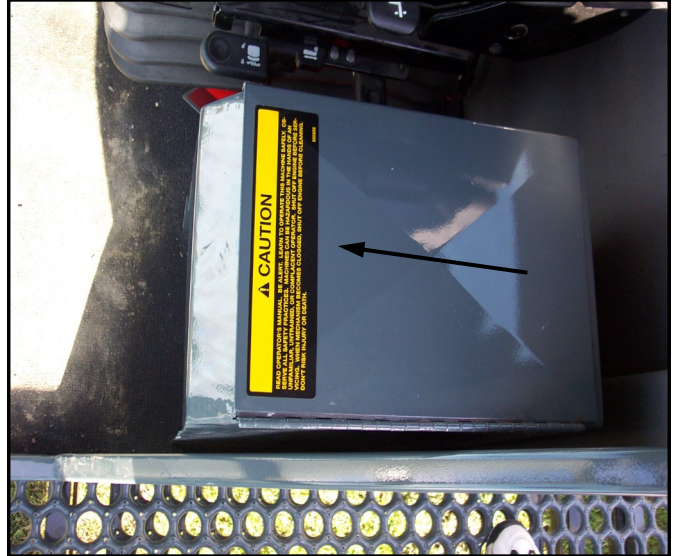

650981

Front of mullion .

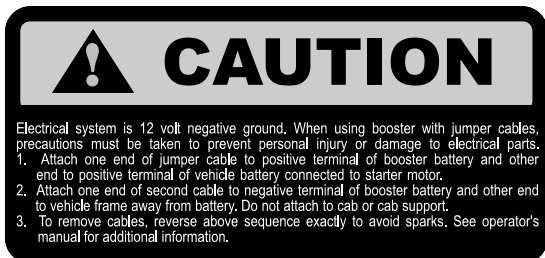
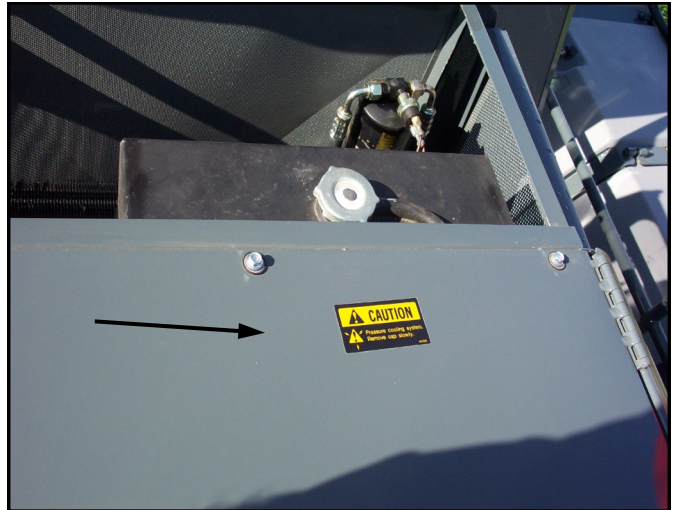

650982

Inside right hood, above battery.

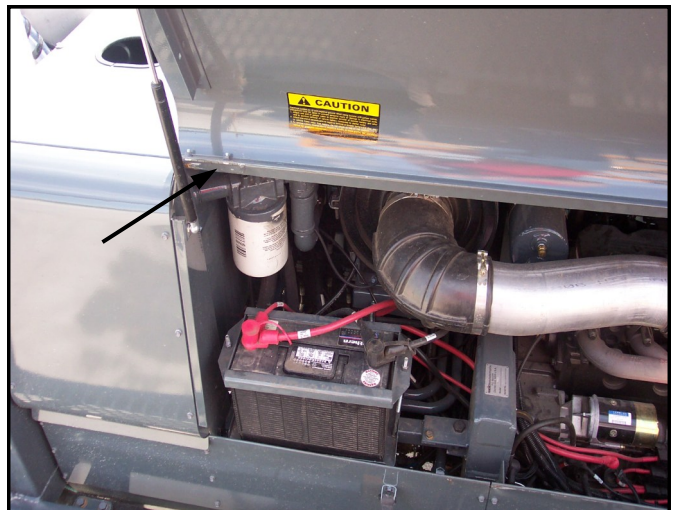

SPRAYER IDENTIFICATION

Each Hagie sprayer is identified by means of a frame serial number. This serial number denotes the model, year in which it was built, and the number of the sprayer. For further identification, the engine has a serial number, the hydrostatic pumps have serial numbers, the wheel motors have identification tags, and the planetary hubs have identification plates that describe the type of mount and gear ratio. To ensure prompt, efficient service when ordering parts or requesting service repairs from Hagie Manufacturing Company, record the serial and identification numbers in the space provided below.

NOTE:

Reference to left-hand and right-hand used throughout this manual refers to the position when seated in the operator's seat facing forward.



Sprayer

NOTE: Sprayer serial number stamped in the frame on right rear corner.



Engine

NOTE: Diesel engine serial number located on the side of the front left gear housing.

II. IDENTIFICATION NUMBERS

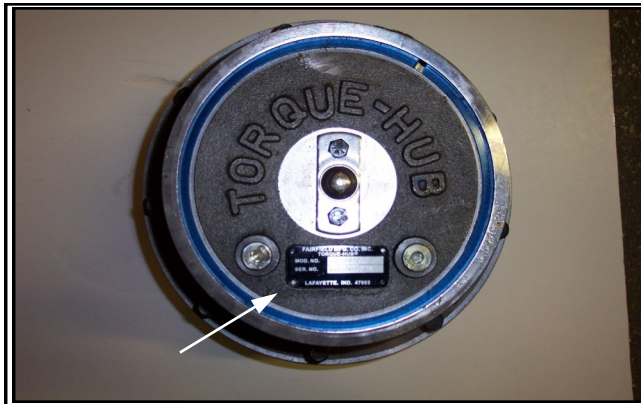

Planetary Hubs

Left

Right

Front: _____

Rear: _____

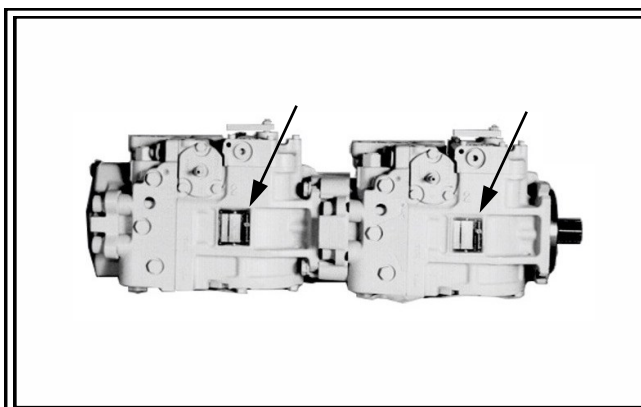

Hydrostatic Pumps

Front: _____

Rear: _____

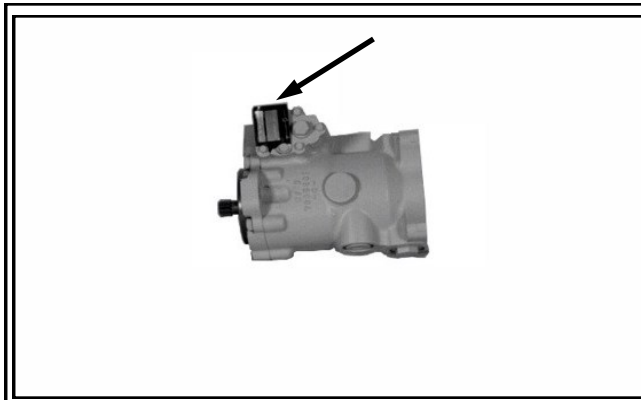

Front Wheel Motors

Left: _____

Right: _____

Refer to parts manual.

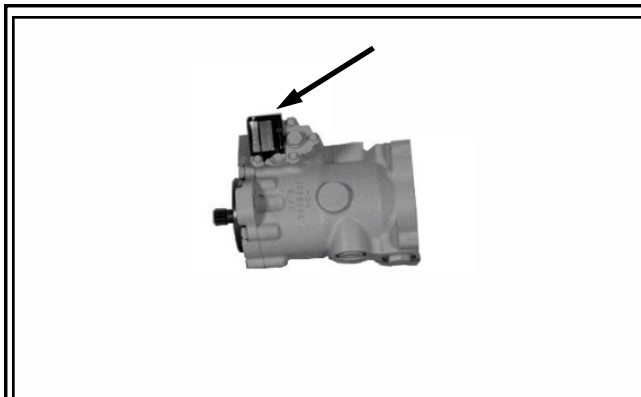

Rear Wheel Motors

Left - w/
Sensor: _____

Right - w/o
Sensor: _____

Refer to parts manual.

III. SPECIFICATIONS

SPRAYER DIMENSIONS

- | | | | |
|-----------------------------------|----------------------|-------------------------------|------|
| A. Overall tractor height | 138.47" | E. Wheel base | 139" |
| B. Raised transom height | 133" | F. Sprayer length | 296" |
| C. Transom lift range | 23"-101" (78" range) | G. Rear handrail height | 124" |
| D. Static loaded hub height | 25.8" | | |

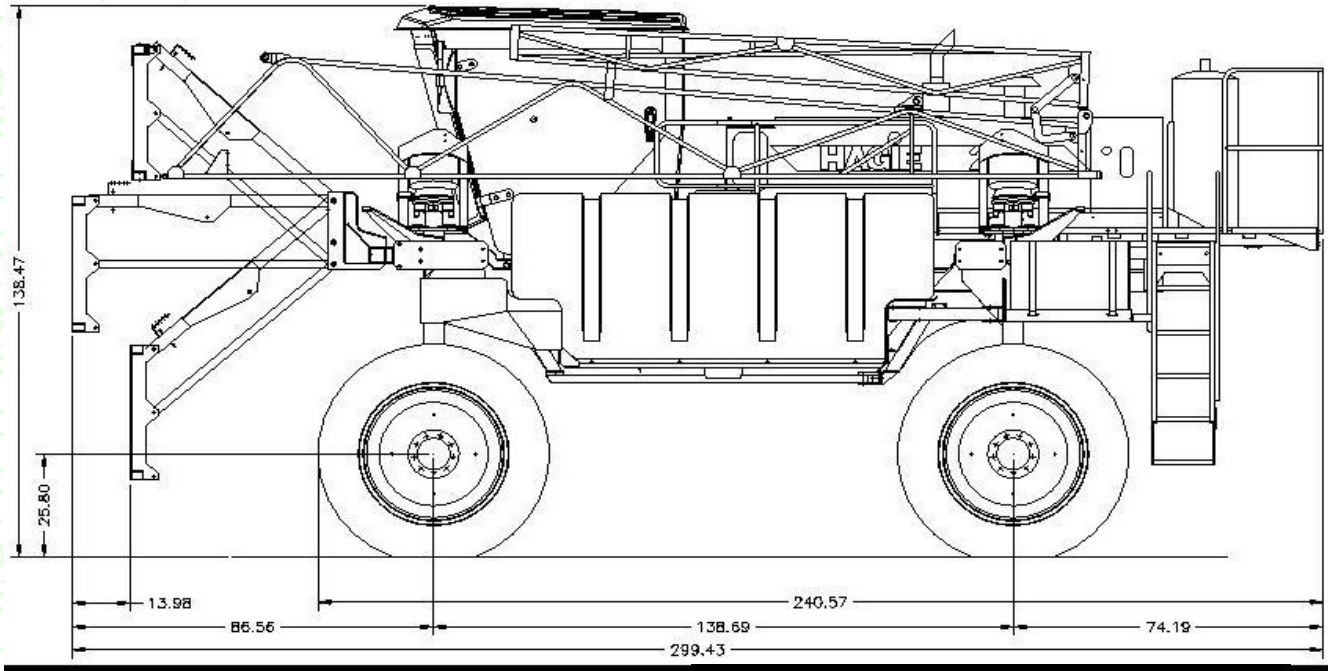

- | | |
|---|--------------|
| H. Width (booms folded, 120" tread) | 143" |
| I. Frame clearance | 73" |
| J. Center clearance | 67" |
| K. Lower leg clearance | 25.5" |
| L. Tire center to inside of lower leg | 14.5" (rear) |
| M. Tread width* | Adjustable |
| | 120" - 144" |
| Optional | Adjustable |
| | 120" - 154" |

*NOTE: Measure tread width at 1/2 tire height.

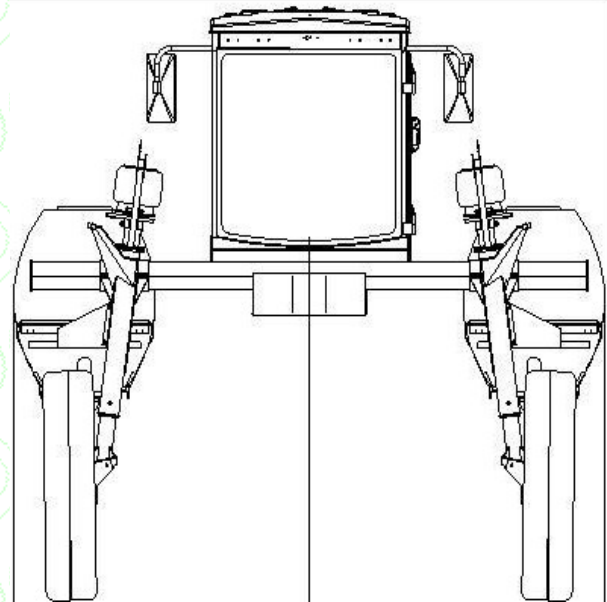

GENERAL SPRAYER INFORMATION

- | | | | |
|--------------------------------|--------------------------------|------------------------|--------------------------|
| ◆ Frame type | Rigid, 4 wheel independent air | ◆ Shipping width | 143" |
| ◆ bag | | ◆ Ladders (2) | Rear |
| ◆ Approximate dry weight | 13,600 lb. | Primary | Side mounted, stationary |
| | | Secondary | Folding, |

III. SPECIFICATIONS

ENGINE

Manufacturer and model	Cummins
Model.....	6BTA6.7 Turbocharged QSB
Type	In line, liquid cooled
Number of cylinders	6
Displacement	6.7 liter
Horsepower	215, intermittent
Type of fuel	Number 1 or number 2 diesel
Fuel system.....	Filtered, direct-injected
Air cleaner	Dry-type, double element
Slow idle.....	800 RPM
Fast idle.....	2720 RPM (no load)

POWER TRAIN

Drive

Hydrostatic pump	Sauer-Danfoss Tandem 90 series
Range.....	132CC(66X2) LIMITED STROKE , (VARIABLE DISPLACEMENT)
Drive train.....	All-time four wheel drive
Speed - Low	0-14 mph
- Medium	0-18 mph
- High	0-28 mph
Hydrostatic wheel motor - front and rear.....	Sauer-Danfoss M46
Final drives	
Type	Planetary gear reduction hubs
- front and rear	Torque Hub® 7000 series 7HBA & 7HBX
Lubrication.....	Oil Bath

Brakes

Type	Integral Spring applied Hydraulically released
------------	--

Steering System

Type	Hydraulic, priority on demand
Control.....	Full-time power
Steering cylinders.....	Self-centering, double action
Turning radius (120" tread setting).....	19' 5"

III. SPECIFICATIONS

AUXILIARY HYDRAULIC SYSTEM

TypeOpen
Pump typeTandem gear
Pressure setting2600 PSI

SPRAY SYSTEM

Booms

TypeDry, with variable row spacing
Standard60 ft. (3 spray sections)
Optional60/80 or 90 ft. (5 spray sections)
ControlsElectro-hydraulic: fold/lift/level
Hydraulic level shock absorberHagie boom level accumulator

Hoses

Rear fill connection (male with adapter for female)2" I.D.
Solution hose from tank1 ½" I.D.
Boom section feeder hose1" I.D.
Boom nozzle hose¾" I.D.

Solution Tanks

StandardTwo 500 gal. polyethylene
with sight gauge
AgitationMechanical - hydraulically driven with
variable speed control

General Spray System

PumpCentrifugal - hydraulically driven with
variable speed control
Solution valvesElectric ball valves
Pressure gauge100 PSI glycerin filled
MonitorRaven 460 (GPS-ready)
Fence row nozzleStandard

FOAM MARKING SYSTEM

MakeHagie Foam Marker
TypeLive air

RINSE SYSTEMS

Spray system rinse (solution tanks, pump, and booms)Standard
High pressure washing systemOptional

III. SPECIFICATIONS

ELECTRICAL SYSTEM

General Electrical System

Battery	Single 12V, negative ground
Alternator.....	150 AMP, voltage regulated
Starter.....	12V with solenoid

Circuit Breakers

Main breaker.....	100AMP
Starter relay.....	30 AMP
Highway and field lights (see below).....	40 AMP
Work lights (see below).....	30 AMP
Foam marker and switch panel auxiliary power.....	30 AMP
A/C and storage console auxiliary power.....	30 AMP
Engine	2x125 AMP

Fuses

Rinse system power and gauges	10 AMP
Hydraulic tread adjust and seat	20 AMP
Spray solution valves	10 AMP
Flow control, agitation, and boom folding controls.....	10 AMP
Fuel and brake	15 AMP
AM/FM radio.....	10 AMP
CB radio power supply and dome light	10 AMP
Tank solution valves and rinse system control	10 AMP
Hazard/warning lights, turns signals, and wiper	10 AMP
Boom lift and level controls	15 AMP

Lights

Front of cab	4 Trapezoid field lights
Rear of cab.....	2 Trapezoidwork lights
Booms	2 Trapezoid work lights (1 each)
Tank shields	2 Trapezoid highway lights (1 each)

Auxiliary Power Supplies

Switch panel.....	12V binding post-type
-------------------	-----------------------

III. SPECIFICATIONS

CAB AND INSTRUMENTS

Cab

General cab.....	Tilt steering Windshield wiper/washer Flashing/hazard warning lights Turn signals Side mirrors Dome light Tinted glass
Temperature control.....	Full-range
A/C charge type	R-134a
Fresh air filtration	Paper and charcoal filter
Seat.....	Air ride with adjustment for: Fore-aft Seat cushion Backrest Height Lumbar Ride firmness Armrest tilt
Storage.....	Right armrest/control station Floor mounted storage console

Instruments

Dial gauges	Hour meter Fuel Temperature Alternator Oil pressure
Digital gauge	Speedometer (MPH-Km/H) Tachometer (RPM)
Engine air filter restriction monitor	Filter Minder®
Stereo.....	AM/FM stereo CD player with dual speakers

III. SPECIFICATIONS

TIRES/RIMS

Rims (front and rear)

Standard.....W 10x 34

Tires (front and rear)

Standard.....320/85R34 (Radial TU)

Air pressure30 PSI

Tire width12.6"

Load capacity (at 20 MPH).....4540 lbs.

Overall diameter55.4"

Static load radius (suggested—will vary with load).....25.8"

Rolling circumference166.9"

Optional (narrow row crop)290/95R34

Air pressure30 PSI

Tire width11.1"

Load capacity (at 20 MPH).....4300 lbs.

Overall diameter55.4"

Static load radius (suggested—will vary with load).....25.4"

Rolling circumference166.9"

CAPACITIES

Solution tanks (2)500 gallons each

Fuel tanks (2)50 gallons each

Cooling system.....10 gallons

Hydraulic reservoir25 gallons

Rinse system tank (optional).....55 gallons

Foam marker stainless steel tank (optional)36 gallons

Engine crankcase (including filter)17 quarts

Torque Hub® (4)23 oz. each (approx.)

IV. PREPARING TO OPERATE

WHEEL TREAD AND ROW SPACING

With hydraulic tread adjust

See pages 38-39 for information about hydraulic tread adjust operation.

Without hydraulic tread adjust

Knowing the row spacing of the field one intends to spray, follow the steps below to properly obtain the desired tread setting.



FIG 4.1

1. To adjust the tread width in or out, park the sprayer on level ground and shut off the engine.
2. Loosen the leg mounting bolts on both the front and rear legs on one side of the sprayer only.

CAUTION

Loosen leg mounting bolts only enough to allow for free movement of leg on mainframe.
DO NOT remove bolts under any condition.

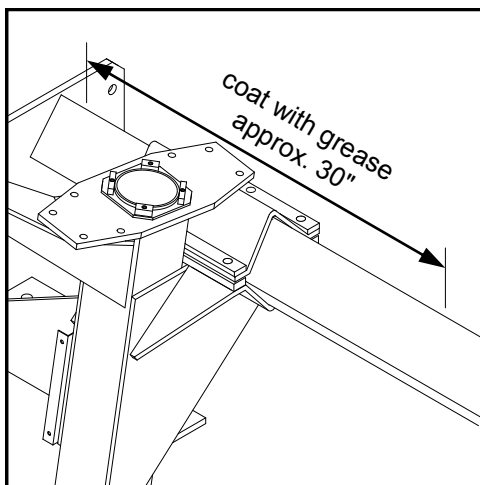

FIG 4.2

3. Loosen the rear lock nut on the leg brace (fig. 4.1). This will allow one leg to move further than the other without binding while adjusting the tread setting.
4. Lubricate the slide path the leg mount will travel along mainframe (fig. 4.2).

IV. PREPARING TO OPERATE



FIG. 4.3

5. Place a suitable block under the air bag mounting plate before raising the sprayer (fig. 4.3). This will prevent the suspension from telescoping.
6. Raise the sprayer until the tires on the side being adjusted are just touching the ground.



FIG 4.4

7. To adjust the tread out, place a suitable prying tool under the center of the tire and pry out at the same time that you push out at the top of the leg. Carefully lower the sprayer to the ground which, in turn will allow the leg to slide outward. Repeat the procedure until the desired tread is obtained.
8. Adjust front and rear legs on one side according to the tread width gauge markers (fig. 4.4).
9. To adjust the tread in, raise the sprayer until the tires on the side being adjusted are just off the ground. Carefully lower the sprayer which, in turn will allow the top of the leg to slide in on the mainframe.
10. Retighten the leg mounting bolts following the torque specs and sequence on page 104.
11. Retighten the leg brace lock nut.
12. Repeat the above procedures to adjust and set the opposite side legs. When finished, all four tread width gauge markers should have identical readings.

IV. PREPARING TO OPERATE

ATTACHING BOOMS AND SETTING NOZZLE SPACINGS

In shipment, some of the sprayer components may not have been assembled and will need to be installed before operating. In order to ensure the proper installation of the components, please read

and comply with the following instructions carefully.

Always make sure you have proper equipment and/or help installing the components.

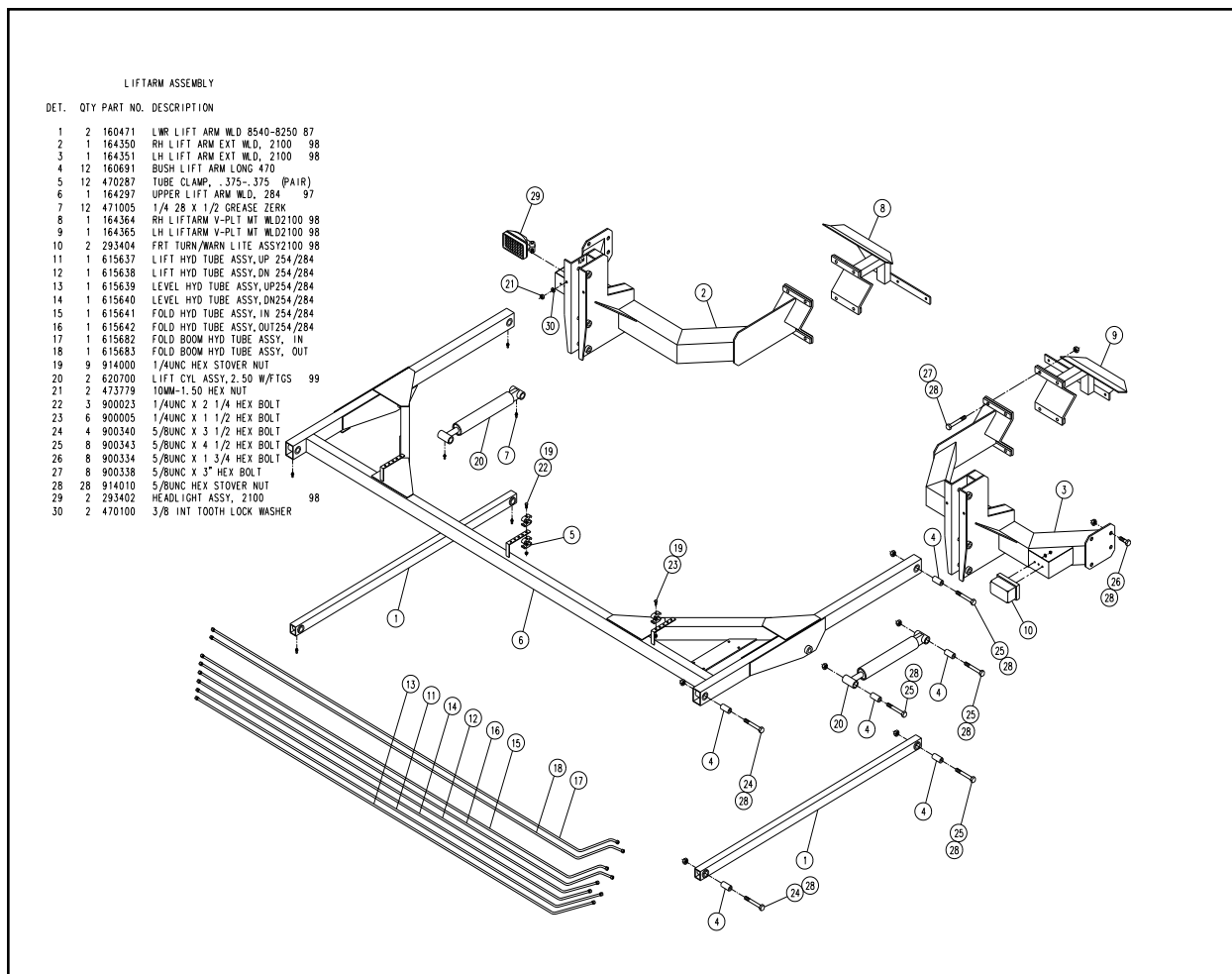

FIG 4.5

1. First, attach right hand (fig. 4.5, items 2 & 8) and left hand (fig. 4.5, items 3 & 9) lift arm mounts and tighten all bolts.
2. Install upper lift arm weldment (fig. 4.5, item 6) to lift arm mounts using proper bushings and bolts provided.
3. Install two lift cylinders (fig. 4.5, item 20), using correct bushings and bolts.
4. After installing the lift cylinders, install two lower lift arm weldments (fig. 4.5, item 1), using correct bushings and bolts.

IV. PREPARING TO OPERATE

1. Install the transom weldment (fig. 4.6, item 17).

NOTE:

An overhead hoist or fork lift is very useful when installing the transom.

2. After the transom is securely fastened, install the outer booms.

NOTE:

Before attaching outer booms, park the sprayer in an open area.

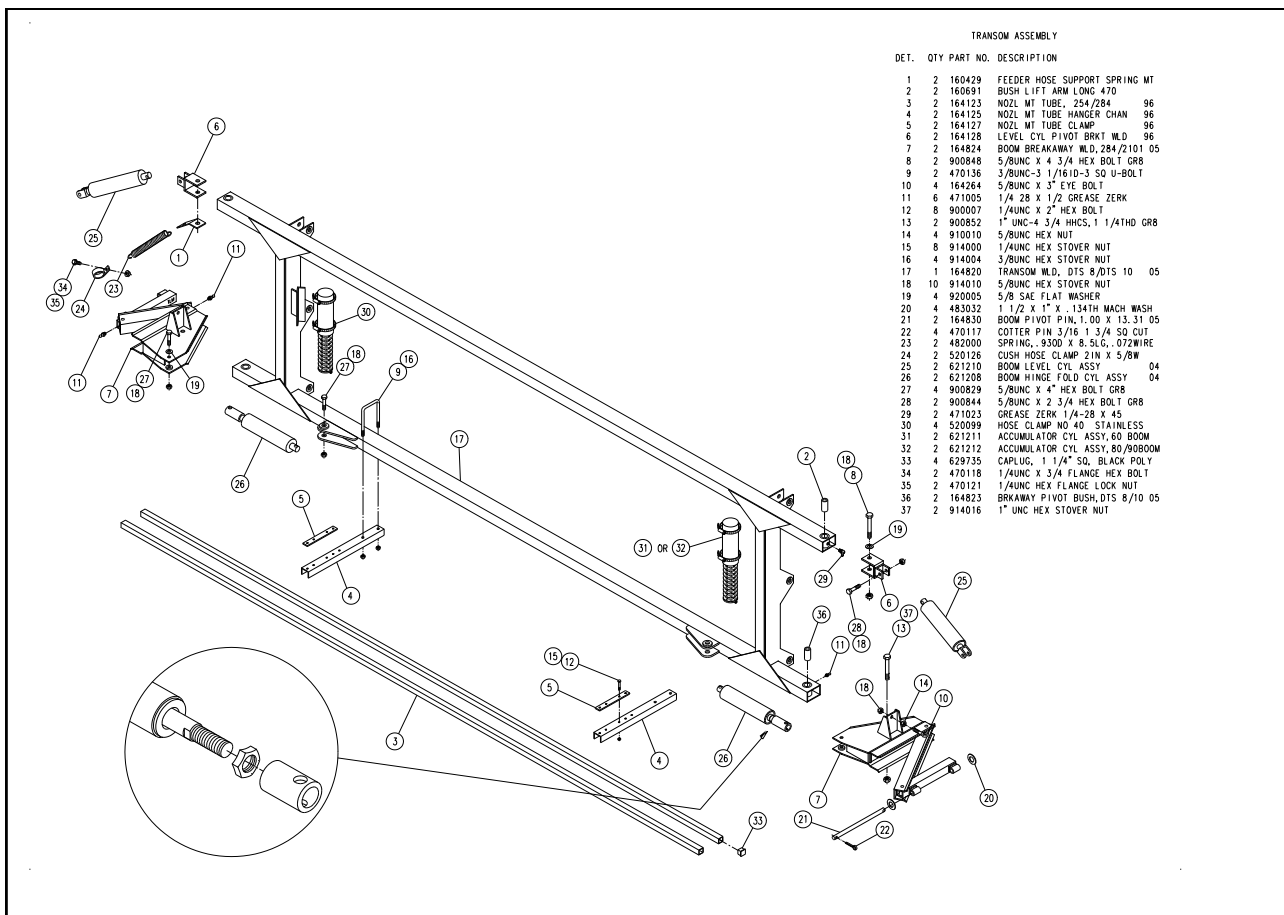

FIG 4.6

IV. PREPARING TO OPERATE

- The booms come in 60 ft., 80 ft., or 90 ft. lengths (fig. 4.8). Refer to the parts manual for detailed drawings for the correct hardware and hydraulic components when attaching to the transom.

NOTE:

Tighten the boom springs until daylight shows between the coils. Do not overtighten.

- After the outer booms have been installed, adjust the fold cylinder sleeve (page 25, fig 4.7, item A) until the booms are parallel with the transom. Then use this same adjustment to allow the boom to fold in far enough to locate in the boom cradle. Lock the cylinder sleeve in place with the jam nut (page 25, fig 4.7, item B).
- After steps 1 through 4 have been completed, mount the nozzle spacings to the outer booms and transom.

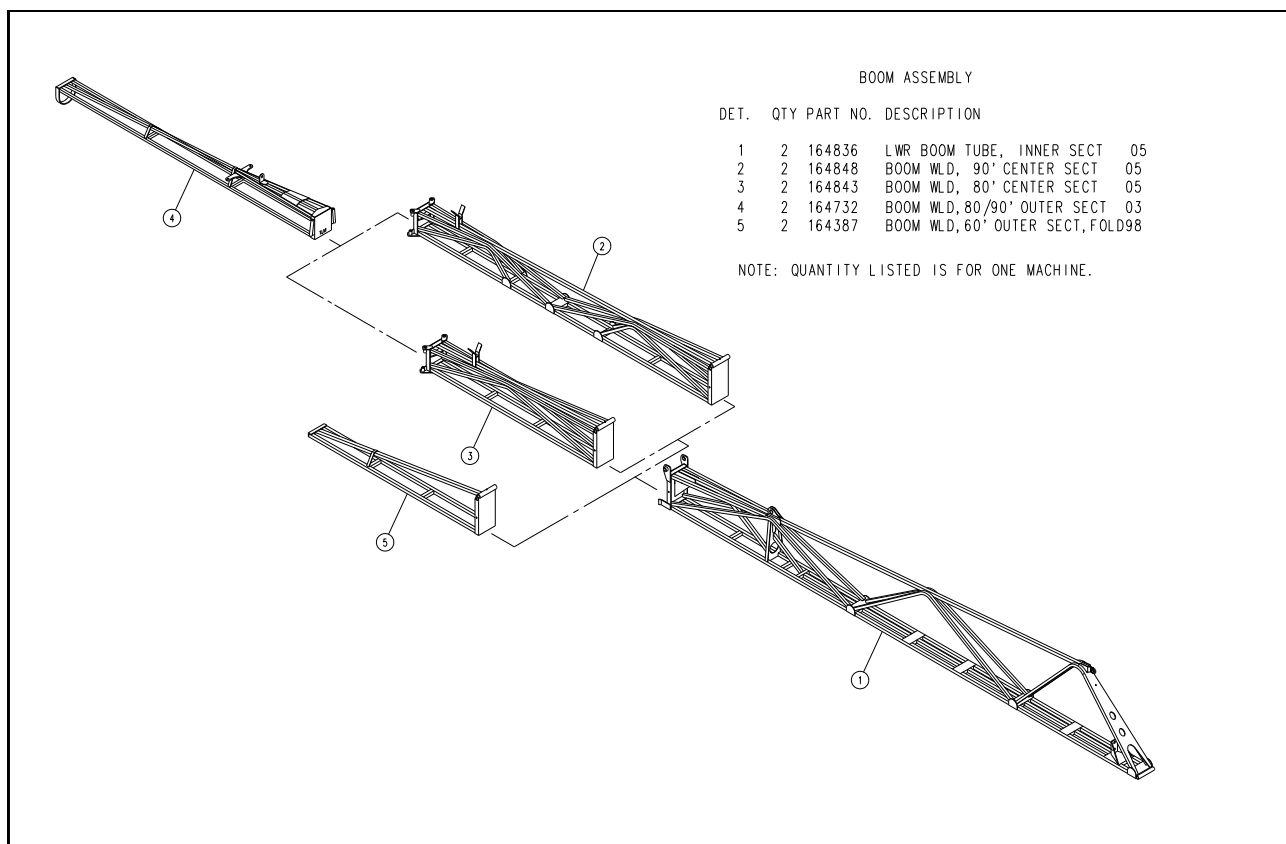

FIG 4.7

IV. PREPARING TO OPERATE



Warning: When operating or positioning the booms observe the following safety items to avoid serious injury or death.

- Select a safe area before folding/unfolding booms.
- Clear area of personnel.
- Check for overhead obstructions.
- Do not fold or unfold booms near power lines. Contact with power lines can result in serious injury or death.



Caution: When operating or positioning the booms observe the following safety items to avoid injury or equipment damage.

- Do not fold/unfold boom extensions when main boom is in the cradle.
- Do not operate sprayer with one boom out of cradle and other boom in cradle.
- Do not transport machine without booms folded and in cradle.

V. OPERATING INFORMATION

OPERATING THE ENGINE

Pre-operational Checks	Page Reference
1. Check the engine oil level. Do not operate the engine when oil is below the low mark on dipstick.	84
2. Check the coolant level in the radiator and the coolant overflow reservoir.	86-87
3. Check the hydraulic oil reservoir level.	83
4. Check cooling air intake screens.	90
5. Check engine drive belt.	102
6. Drain fuel/water separator.	92
7. Check the Filter Minder [®] .	89
8. Check for any oil or fuel leaks and correct if needed.	

Starting the Engine

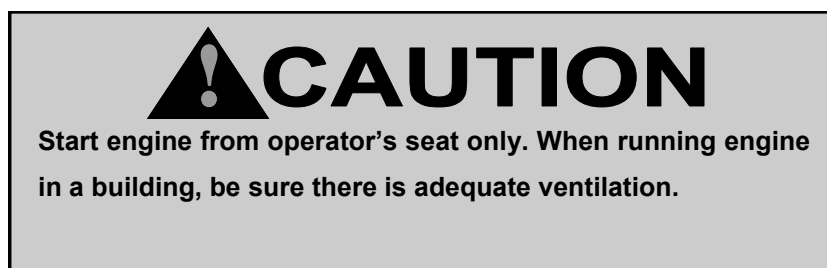

1. Position hydrostatic control lever to "N" (neutral) position.
2. Put the parking brake switch to the "ON" position. (See page 36) When starting procedure is complete, return switch to "OFF" position.
3. Start the engine with the switch at idle position.
4. Turn key to the "ON" position to check instruments, and let the WAIT TO START light to go out.

V. OPERATING INFORMATION

5. Turn the ignition key switch to the start position to engage the starter. If the engine fails to start after 15 seconds, turn key to "OFF", wait one minute and repeat the procedure. If the engine does not start after three attempts, check fuel supply system. Absence of blue or white exhaust smoke during cranking indicates no fuel is being delivered.
6. When engine starts, inspect indicator lights and gauges for operation. If any lights or gauges do not operate, shut off engine and determine cause.
7. Always allow at least a five minute warm-up period before operating the engine at high RPM. This means the engine must reach operating temperature and oil pressure must stabilize in the normal operating range before it is run faster than an idle (1000 RPM or less). Cold oil may not flow in quantities adequate to prevent pump cavitation.

COLD WEATHER STARTING

USING STARTING FLUID IS NOT RECOMMENDED:



CAUTION



When using jumper cables to start engine, make sure to connect the cables in parallel: positive (+) to positive and negative (-) to negative. When using an external electrical source to start the engine, turn the disconnect switch to the "OFF" position. Remove the key before attaching the jumper cables to prevent unintentional starter engagement.

V. OPERATING INFORMATION

CANTRAK 2600 ENGINE MONITOR SYSTEM

The following information is a quick overview of the unit. For further reference, please see CANtrak 2600 systems manual.

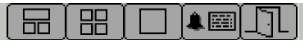
Hagie Manufacturing suggests locking monitor to eliminate parameter settings getting changed: **LOCK/UNLOCK:** In QUAD MODE, hold F1 and F2 keys simultaneously for 5 seconds

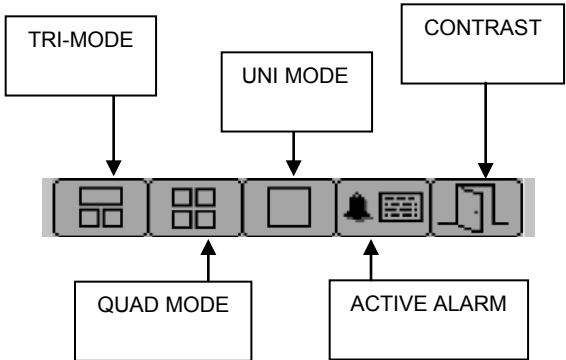
<p>The CANtrak 2600 system is used to monitor engine parameters. It is programmed to Hagie configured settings eliminating user required set-up. The start-up screen is shown on the right.</p>	 <p>START -UP SCREEN</p>
<p>After the initial start-up screen, you will see the quad mode display shown on the right.</p> <ul style="list-style-type: none"> Top-left quadrant: <i>engine speed</i> Top-right: <i>vehicle speed</i> Bottom-left: <i>oil pressure</i> Bottom-right: <i>coolant temperature</i> <p>At anytime using this monitor, press F1 or F2 key to display the context dependent "button bar," like the one shown below.</p> 	 <p>QUAD MODE SCREEN</p>
<p>This top-level button bar shows the basic structure of the monitor and disappears after 5 seconds of inactivity.</p> <ul style="list-style-type: none"> Press F1 to view the Tri-mode display shown in the next box below Press F2 to view the Quad-mode shown above Press F3 to view the Uni-mode shown below Press F4 to view the Active Alarm mode shown below Press F5 to view the Contrast mode or hold for 3 seconds to view Configuration Menu show below 	

V. OPERATING INFORMATION

The Tri-mode display is shown on the right:
 Top: *total engine hours*
 Bottom-left: *fuel rate*
 Bottom-right: *systems voltage*
 Press F2 to go back to quad mode display or F3 to see the Uni display mode on the next page.

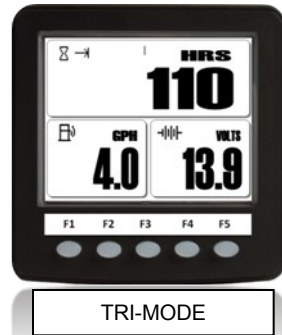

TRI-MODE

The Uni display mode plots the data history in an X-Y graph format. Please refer to *page 12* of the manual for further info.



UNI DISPLAY

The Active Alarm display mode lists all active/current alarms received by the unit. Please refer to *page 18* of the manual for further info.

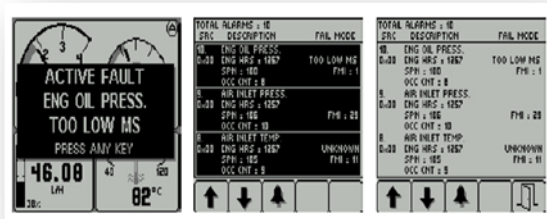

ACTIVE ALARM LISTS

The Configuration Menu is shown on the right. For further information regarding configuration settings refer to *page 20* of the manual.



CONFIG MENU

V. OPERATING INFORMATION

HYDROSTATIC SYSTEM



FIG 5.1

Hydrostatic Drive

1. Speed ranges are selected by a three-position electronic switch mounted on the console (fig. 5.1, item 3). The lower the setting, the higher the torque, but the lower the speed.
2. Increase engine RPM with the throttle switch (fig. 5.1, item 2) to the maximum recommended engine speed setting.

NOTE:

Never operate the sprayer at anything less than full recommended throttle.

3. To move forward, slowly push hydrostatic control lever (fig. 5.1, item 1) forward. The farther the control lever is moved, the faster the sprayer will travel. To stop, slowly pull the lever to the " N " (neutral) position.
4. To reverse the machine, slowly pull the hydrostatic control lever back. To stop, slowly push the lever to the " N " (neutral) position.
5. Before turning off the engine, reduce engine speed and allow the engine to idle at least three minutes.

V. OPERATING INFORMATION



FIG 5.2

Parking Brake

The brakes are controlled by charge pressure. When the engine is shut off or if the charge pressure is below 150 PSI the brakes will become activated. To set the brakes while the engine is running, activate the switch located on the left front part of consol panel (fig. 5.2). To engage brakes , push switch up to “OFF” position. Push switch down for “ON” position before moving sprayer.

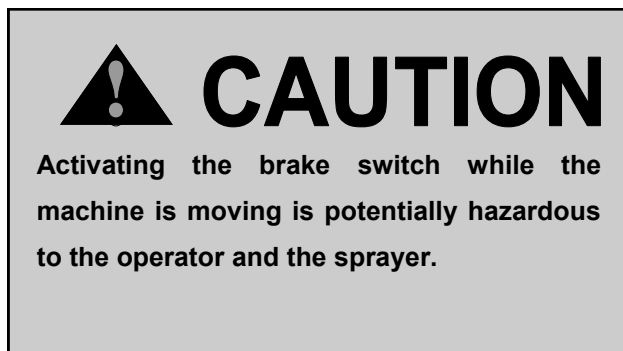

V. OPERATING INFORMATION

HYDRAULIC SYSTEM

The auxiliary hydraulic system is an open center type directly mounted behind the heavy duty variable displacement pump. This system consists of dual gear pumps that supply the required hydraulics to operate the full time power steering unit, boom control cylinders (lift, level, fold), the solution pump, mechanical agitation, and if equipped, hydraulic tread adjust.

After supplying each of these systems, the hydraulic oil is sent to the oil cooler in front of the engine coolant radiator. Here it is cooled and then sent back to the hydraulic oil reservoir.



FIG 5.4

NOTE:

Immediately shut down engine if low level hydraulic oil light comes on in cab (fig. 5.4).



CAUTION

DO NOT GO NEAR LEAKS. High pressure oil easily punctures skin causing injury, gangrene, or death. If injured, seek emergency medical help. Immediate surgery is required to remove oil. Do not use finger or skin to check for leaks. Lower load or relieve hydraulic pressure before loosening fittings.

V. OPERATING INFORMATION

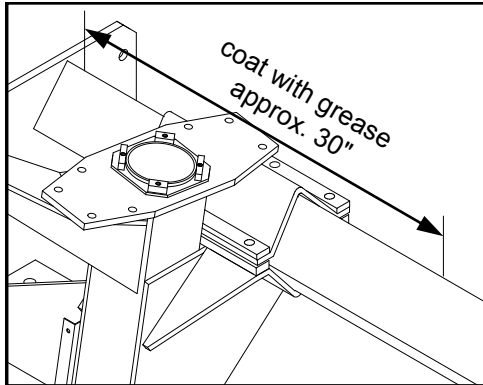

FIG 5.5

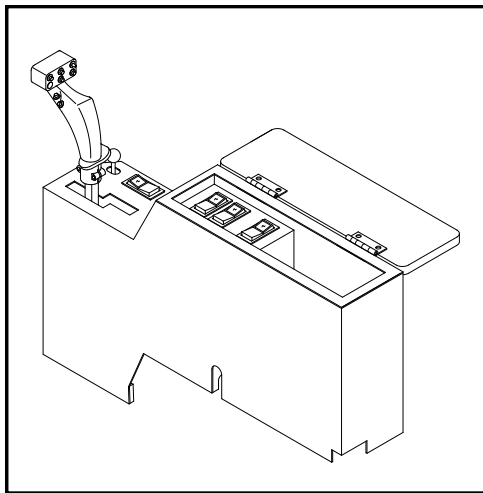

FIG 5.6

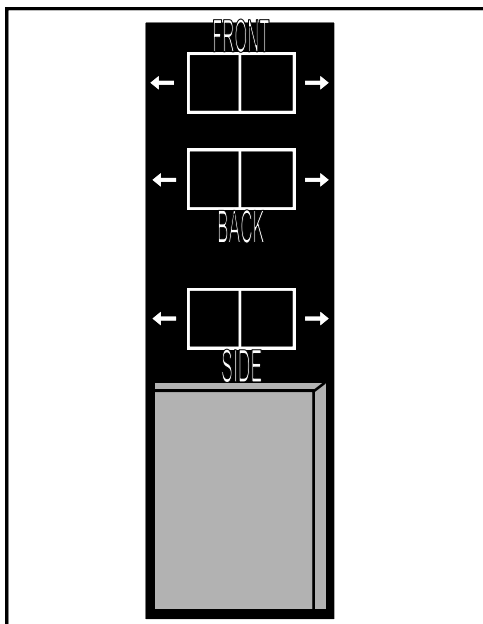

FIG 5.7

Operating the Hydraulic Tread Adjust



Never adjust the hydraulic tread on a public roadway. Make sure the sprayer is on level ground where there are no ditches or valleys to interfere when you perform the adjustment.

NOTE:

The hydraulic tread adjust bearing clearance has been factory set. If further adjustment is required for more or less clearance, additional shims will need to be added or removed (see page 106).

Before you hydraulically adjust the tread:

1. Make sure the nylon material on the tread adjustment brackets on both the front and rear legs have an adequately lubricated surface to slide on during adjustment (fig. 5.5).
2. Survey the surroundings and allow yourself enough room to adjust tread either in forward or reverse.

Operating the Hydraulic Tread Adjust

NOTE:

Always adjust tread between 1 and 2 MPH; it may be adjusted in forward or reverse.

1. Locate switch panel under lid of seat-mounted console (fig. 5.6) and select the button marked "SIDE" (fig. 5.7). Depressing either side of the button will select the corresponding side of tread to be adjusted.
2. The legs may be moved in or out on each side independently. Press and hold the front and/or back switch simultaneously or separately.

V. OPERATING INFORMATION



FIG 5.8

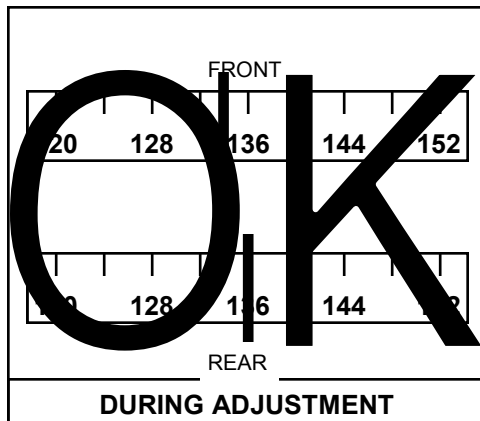

FIG 5.9

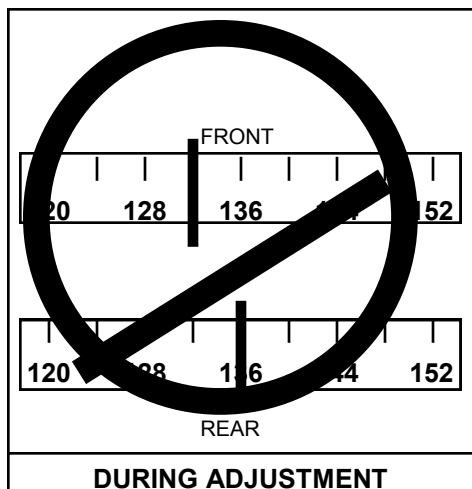

FIG 5.10

NOTE:

When operating the hydraulic tread adjust you will notice a squealing-type noise. This noise is the hydraulic fluid reaching the relief setting. Do not be alarmed of this noise during adjustment.

3. Observe the tread width indicator on each leg (fig. 5.8). Release the switch when the tread indicator reaches the desired tread marking. When finished, the front and rear indicators should have identical measurements.

NOTE:

If adjusting front and rear legs independently, do not allow the difference between the two to become greater than two inches according to the tread indicators (or one actual inch). (See figures 5.9 and 5.10.) If it does, damage may occur.

4. With one side complete, depress the "SIDE" switch to select the other side. Repeat the above procedure for the other side.
5. All four tread width indicators should have identical readings.
6. Return the "SIDE" selection switch to the center neutral position and close the lid.
7. To recalibrate toe-in: while driving forward slowly, turn the steering wheel all the way one way until the steering cylinder bottoms out; continue turning the wheel a little more to let fluid bypass the cylinder. Then turn the steering wheel all the other way and repeat the process. When wheels are then straightened, steering cylinders should be recentered and correct toe-in should be obtained.

NOTE:

To correctly measure toe-in, see page 100.

V. OPERATING INFORMATION

SPRAY BOOMS



Warning: When operating or positioning the booms observe the following safety items.

- Select a safe area before folding/unfolding booms.
- Clear area of personnel.
- Check for overhead obstructions.
- Do not fold or unfold booms near power lines. Contact with power lines can result in serious injury or death.



Caution: When operating or positioning the booms observe the following safety items to avoid injury or equipment damage.

- Do not fold/unfold boom extensions when main boom is in the cradle.
- Do not operate sprayer with one boom out of cradle and other boom in cradle.
- Do not transport machine without booms folded and in cradle.

V. OPERATING INFORMATION

SPRAY BOOMS

Spray booms are available in three different lengths: 60 ft., 80 ft., and 90 ft. Folding and locking the outer breakaway and turning off the two outer boom solution valves essentially makes an 80 ft. boom into a 60 ft. boom (see page 47).

The spray booms are controlled by an electro-hydraulic system. This system consists of operator manipulated switches located in the sprayer's cab and hydraulic cylinders attached to the booms. It provides control of lift (page 42), level (page 43), and horizontal and vertical fold (pages 44 and 45).

All DTS 10 spray booms are equipped with a main boom two-way, spring-loaded breakaway. Eighty and ninety foot spray booms are also equipped with a one-way spring-loaded breakaway on the outer boom section.

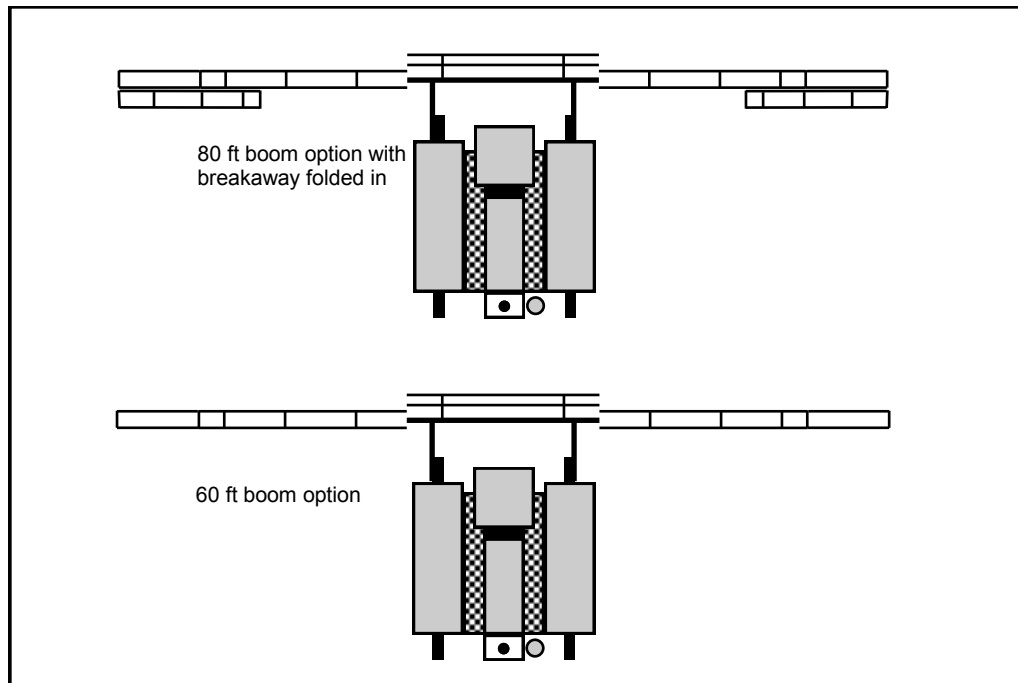

FIG 5.11

V. OPERATING INFORMATION



FIG 5.12

Lift

To raise and lower the transom/boom assembly, depress the “GRAY” (UP) or the “RED” (DOWN) buttons on the hydrostatic drive handle (fig. 5.13, item 1 & 2). While depressed, either button activates the transom lift cylinders (fig. 5.12).

See your spray tip manufacturer’s guide for information regarding spray tip height (fig. 5.14).

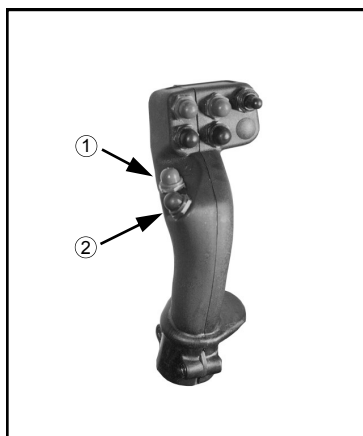

FIG 5.13

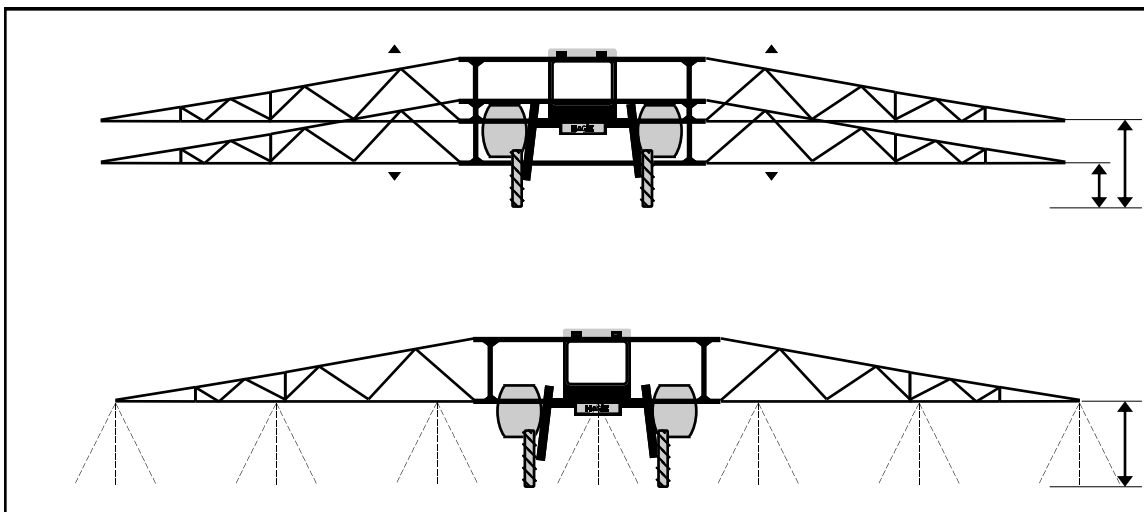

FIG 5.14

V. OPERATING INFORMATION



FIG 5.15

Level

To increase or decrease the angle of each individual boom level, depress the left or right “GRAY” (UP) or the left or right “RED” (DOWN) buttons on the hydrostatic drive handle (fig. 5.16, items 1 thru 4). While depressed, these buttons activate the level cylinders connecting either boom to the transom (fig. 5.15).

This adjustment also aids in placing the booms correctly in the cradles for transporting and storing.

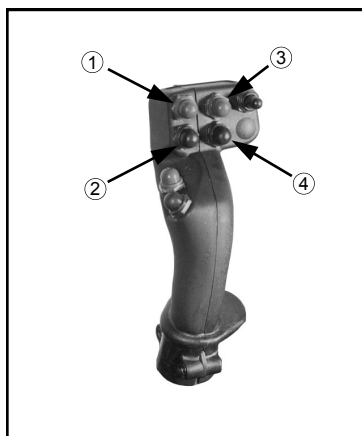

FIG 5.16

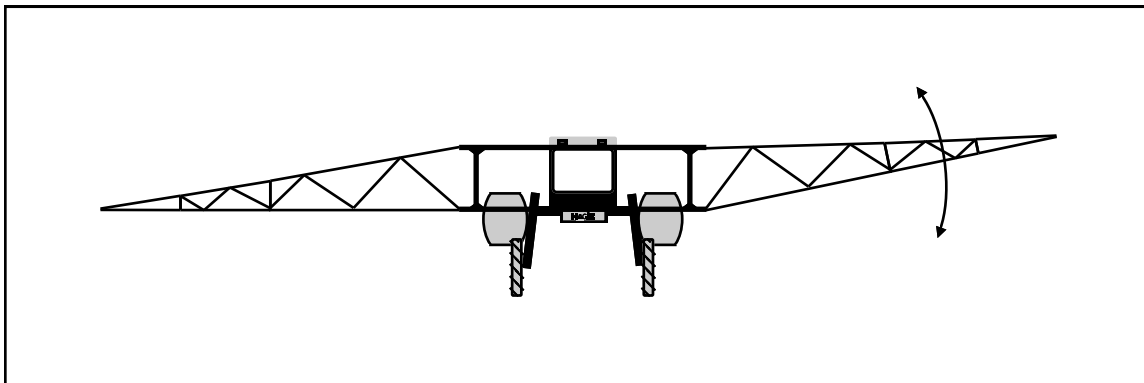

FIG 5.17

V. OPERATING INFORMATION

Fold



FIG 5.18

HORIZONTAL BOOM FOLD - To fold either boom horizontally in toward the machine or out away from the machine,(first the machine must be in the neutral position),depress the “IN” or “OUT” of either or both “BOOM FOLD” switches (fig. 5.19). While depressed, these switches activate cylinders connecting either boom breakaway mount to the transom (fig. 5.18).

Fold or unfold the booms in an open area only. Make sure no one is standing in the path of the boom fold’s travel path.



FIG 5.19

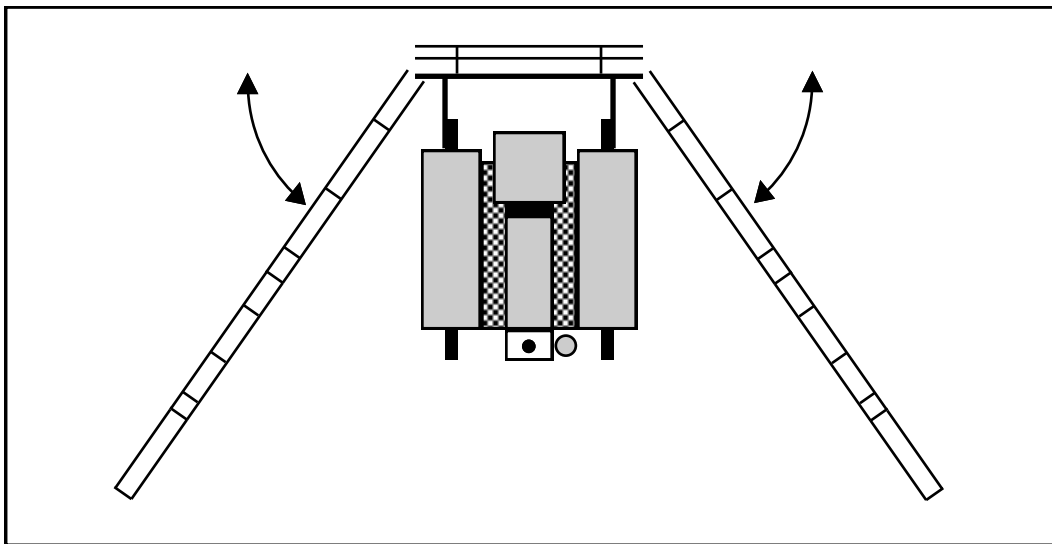

FIG 5.20

V. OPERATING INFORMATION



FIG 5.21

Fold

VERTICAL EXTENSION FOLD - To fold the boom extensions vertically in or out, machine must be in neutral position then depress the “IN” or “OUT” of the “EXTENSION” switch (fig. 5.22). This activates both extension cylinders connecting the inner boom section and the center boom section (fig. 5.21).

Fold or unfold the booms in an open area only. Make sure there are no overhead obstructions or wires to interfere with extension folding.

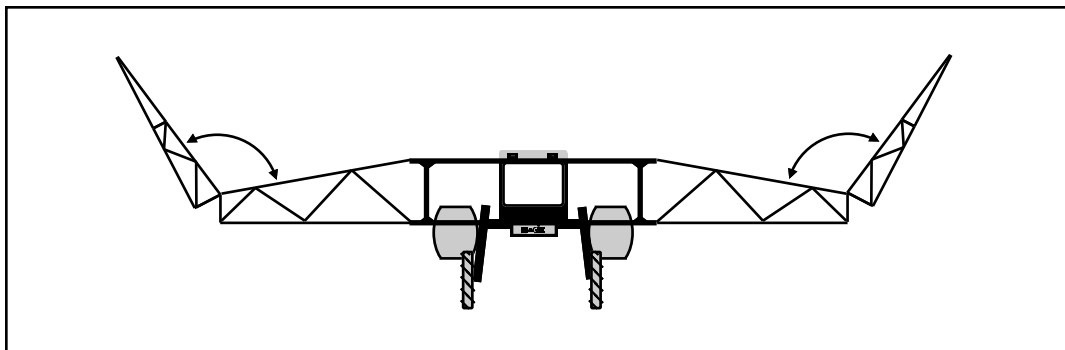
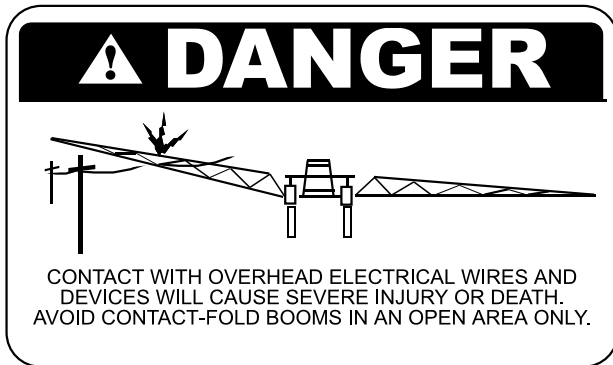

FIG 5.23

V. OPERATING INFORMATION



FIG 5.24



FIG 5.25

Cradling Booms

The booms should always be cradled when traveling, transporting, or parking for an extended period of time. The booms must be folded when cradled. To cradle the booms, fold the boom extensions in, raise the transom, and fold the booms in toward the machine. The closer the booms get to the cradle, the more careful you need to be while making adjustments to avoid damage. Raise each individual boom level until it clears the outer cradle stop (fig. 5.24). Fold the boom in toward the cradle back-stop. When it touches the back-stop, lower the boom level until the full weight of the boom rests in the cradle (fig. 5.25). If the boom does not fold in far enough, the fold cylinder sleeve may need to be adjusted (see page 25).

NOTE:

Booms must be in folded position when cradled. Failure to do so may cause boom damage.

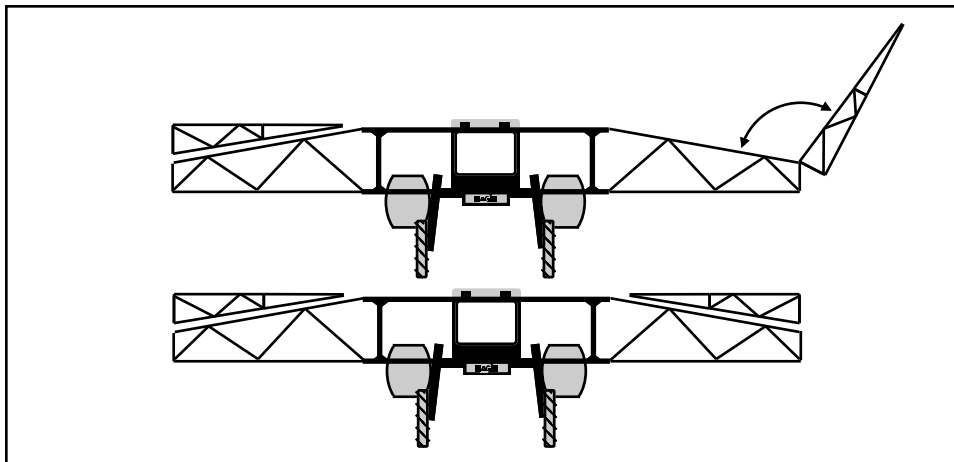

FIG 5.26

V. OPERATING INFORMATION



FIG 5.27

Folding 80' Boom to 60' Boom

To convert an 80 foot boom to a 60 foot boom, close the solution supply valves to the outer sections (see page 47). Manually fold each outer boom section backward (fig. 5.27) and lock in place with lock pin (fig. 5.28).

NOTE:

The outer boom section should be locked down if in the folded position to prevent boom damage.



FIG 5.28

V. OPERATING INFORMATION

SPRAY SYSTEM



Warning: When operating or positioning the booms observe the following safety items.

- Select a safe area before folding/unfolding booms.
- Clear area of personnel.
- Check for overhead obstructions.
- Do not fold or unfold booms near power lines. Contact with power lines can result in serious injury or death.



Caution: When operating or positioning the booms observe the following safety items to avoid injury or equipment damage.

- Do not fold/unfold boom extensions when main boom is in the cradle.
- Do not operate sprayer with one boom out of cradle and other boom in cradle.
- Do not transport machine without booms folded and in cradle.

V. OPERATING INFORMATION

SPRAY SYSTEM

The spraying system is a constantly-monitored and continuously-adjusted computer-controlled system. The cab-mounted digital monitor receives information from various inputs to help determine GPM (gallons per minute) and GPA (gallons per acre).

SPRAY SYSTEM OPERATION INSTRUCTIONS

OPERATION	PAGE REFERENCE
1. Calibrate spraying system monitor.	75-76
2. Check contents and quantity in spray tank.	

NOTE:

Never attempt to operate the spray system without solution in the spray tank. Operating the spray system with no solution in the tank will cause severe damage and void the warranty.

3. Completely open the tank valves.	53
4. Start engine and maintain a relatively low engine RPM setting (1,000 RPM). Increase engine RPM slowly until full recommended operating RPM is reached.	31-32
5. If desired, activate the agitation system.	55
6. Turn on the solution pump switch.	50
7. Turn on main spray power.	51
8. Place individual boom solution valve switches to the "ON" position.	51
9. Slowly move the hydrostatic control lever forward to obtain the desired ground speed.	34
10. Frequently observe the pressure gauge. When it drops to zero, or spray pattern deteriorates, shut off main spray power, solution pump, and agitation system until refilling solution.	50-54

V. OPERATING INFORMATION



FIG 5.29

Solution Pump

The solution pump is a hydraulically driven centrifugal pump (fig. 5.29) with variable speed control. Engage the solution pump with the solution pump switch (fig. 5.30) while at a relatively low engine RPM setting (1,000 RPM). Increase engine RPM slowly and maintain full recommended throttle RPM for field operation.

NOTE:

DO NOT allow the pump to continue running when the boom switches are turned off. Failure to do so will generate over-heating and cause severe pump damage and void the warranty.



FIG 5.30

Solution Pressure Gauge

The solution pressure gauge (fig. 5.31) gives the operator a constant visual display of the amount of solution being applied (measured in PSI). The pressure (as determined by the monitor-controlled variable flow control) will vary according to ground speed. If applying solution manually, the solution pressure gauge visually informs the operator of needed manual adjustments.



FIG 5.31

V. OPERATING INFORMATION



FIG 5.32

Electric Solution Valves

The spray booms are divided into sections that are independently supplied with solution and can therefore independently be shut off or turned on. The number and location of solution valves varies with boom length. Sixty foot booms are divided into three sections and the valves are mounted on the transom. Eighty and ninety foot booms are divided into five sections with three valves mounted on the transom and one mounted on each boom.



FIG 5.33

Boom Valve Switches

The electronic boom solution valves are controlled by a panel of switches mounted under the spraying system's monitor (fig. 5.32). When the switches are in the "UP" position they are on and when they are in the "DOWN" position they are off.

Boom Section L.E.D. Indicators

Boom solution valve status is displayed on the transom by a series of L.E.D. indicators (fig. 5.33). Each indicator will light up if that particular boom solution valve is turned "OFF."

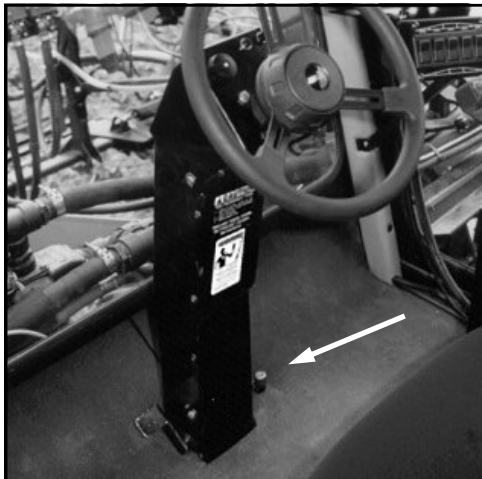

FIG 5.34

Main Solution Switch

The main solution switch is a floor-mounted "dimmer-style" switch (fig. 5.34). It controls the power supply to the panel of boom solution valve switches. The main floor switch must be on to supply the panel switches with voltage. This way you can turn all of the boom solution valves "ON" or "OFF" all at once in a hands-free execution such as turning the main solution switch "OFF" as you arrive at the end rows of a field and turn it back "ON" as you enter the field again.

When the main solution switch is "ON" a "GREEN" indicator light located under the monitor will light up (fig. 5.32, item 1). When the light is not lit, the main solution switch is "OFF."

V. OPERATING INFORMATION

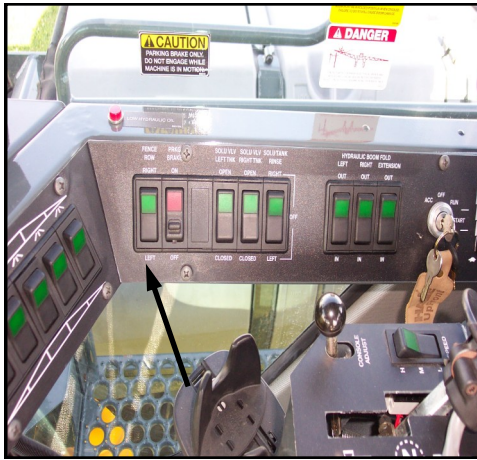

FIG 5.35



FIG 5.36

Fence Row Applicator

To operate the fence row nozzle, locate the fence row switch at the front of the switch control panel (fig. 5.35). If you wish to turn on either the right or left fence row nozzle, depress the corresponding “RIGHT” or “LEFT” side of the fence row switch. To turn either fence row nozzle off, return the fence row switch back to the center (“OFF”) position.

As you engage either fence row nozzle you may notice a drop in solution pressure.

A set of amber L.E.D. lights mounted on the transom on either side of the boom solution valve L.E.D. lights will inform the operator of fence row status. If the right fence row nozzle is on, the right amber L.E.D. light is lit (fig. 5.36, item 2). If the left fence row nozzle is on, the left amber L.E.D. light is lit (fig. 5.36, item 1). If neither amber L.E.D. light is lit, no solution is being applied through the fence row nozzles.

SIXTY FOOT BOOM – The fence row nozzle on a sixty foot boom is supplied by an electric valve mounted in-line with the left or right boom solution supply hose. In order to operate the fence row nozzle on a sixty foot boom, the corresponding boom section (left or right) must already be on.

EIGHTY OR NINETY FOOT BOOM – The fence row nozzle on an eighty or ninety foot boom is supplied by an electric valve attached to the outer boom electric solution valve. The fence row nozzle on an eighty or ninety foot boom may be operated by itself.

V. OPERATING INFORMATION



FIG 5.37

Tank Shutoff Valves

To shutoff either or both solution tank sumps, manually close either or both 1½" ball valve(s) located under each solution tank (fig 5.37). Your sprayer is equipped with optional 1½" electric tank shutoff valves (fig. 5.38, item 3).

To operate the electric tank shutoff valves, locate the solution tank switches in the console. To open or close the left solution tank, depress the "OPEN" or "CLOSED" side of the left switch (fig 5.38, item 1). To open or close the right solution tank, depress the "OPEN" or "CLOSED" side of the right switch (fig. 5.38, item 2).

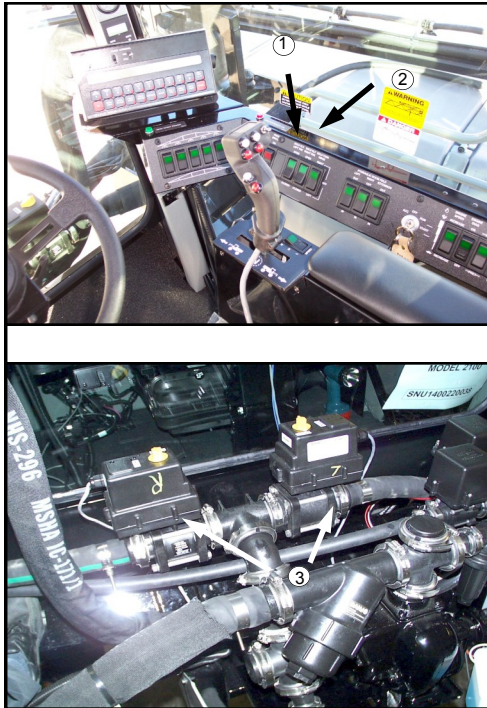

FIG 5.38

Utilize the tank shutoff valves when: 1 - you wish to draw solution from only one tank or the other; 2 - you are operating on unlevel ground such as a hillside or terrace and you don't want solution to siphon from one tank to the other (fig. 5.39); or 3 - you operate the rinse system (see pages 54-56).

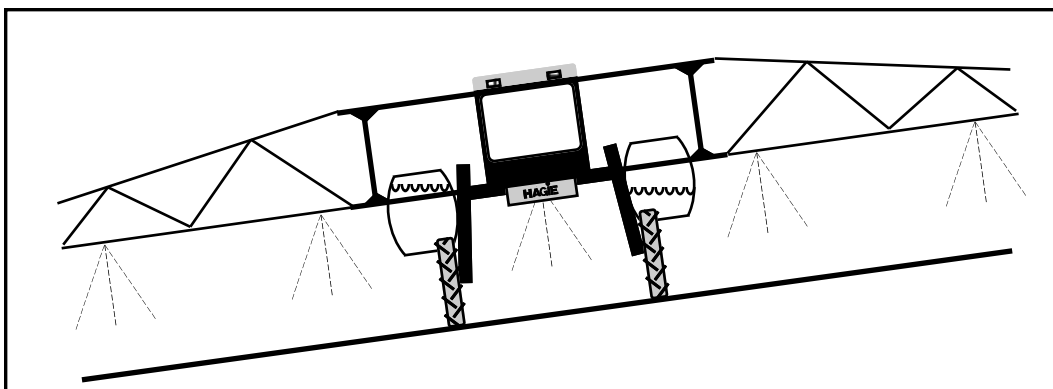

FIG 5.39

V. OPERATING INFORMATION

▶ SPRAYING SYSTEM CONTINUED

Rear Fill



FIG 5.40

To fill the solution tanks, make sure the manual tank shutoff valve (fig. 5.41A) under the tank, and the electric valve (fig.5.41B) on top of solution pump you want to fill , is open (you may fill both at the same time). The corresponding fill valve(s) in the rear must also be open (fig. 5.42).

Remove the rear fill connection from its cradle. Connect it to your solution supply and fill to the desired level (fig. 5.40). When done, shut the rear fill valve(s) and return the rear fill to its cradle.



FIG.5.41A

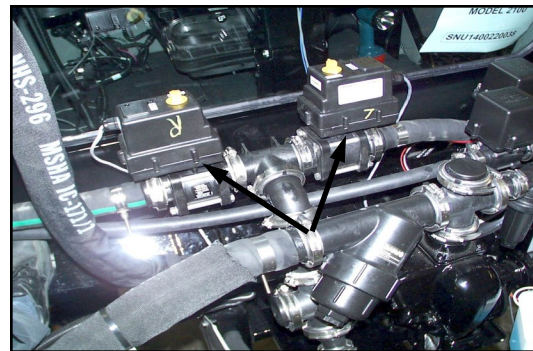

FIG.5.41B

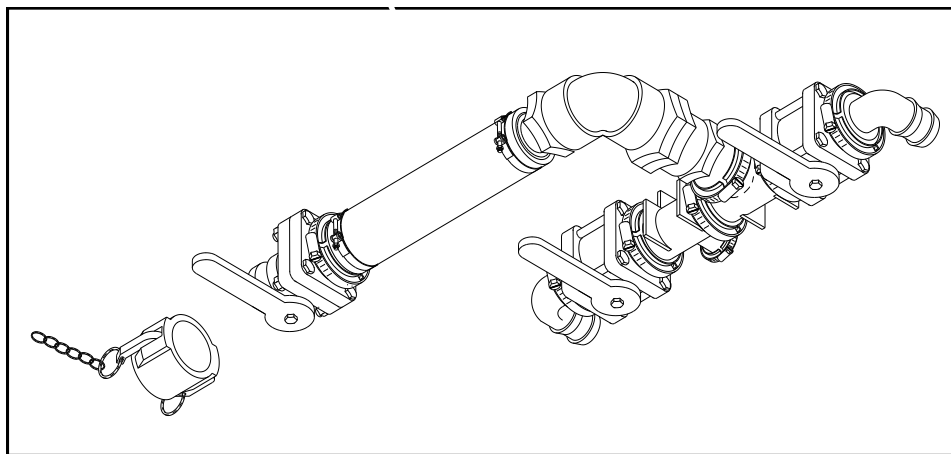

FIG 5.42

V. OPERATING INFORMATION

AGITATION SYSTEM

The Hagie DTS 10 comes standard with a hydraulically-driven mechanical agitation system to maintain suspension of solution in the sprayer's tanks.

To activate the system turn the "TANK AGITATION" switch (fig. 5.43) to the "ON" position. This will deliver hydraulic fluid to agitator motors on both solution tanks (fig. 5.44) turning the agitator shaft assemblies clockwise.



FIG 5.43



FIG 5.44



FIG 5.45

NOTE:

Operation of the agitation system with no solution in the spray tanks will void the warranty on the agitation system.

Agitator motor speed is governed by a manual variable flow control valve mounted on the rear of the sprayer (fig. 5.45). To adjust the speed loosen the set knob on the variable flow control handle; turn the lever to the desired speed and retighten the set knob.

V. OPERATING INFORMATION

The gland packing (fig. 5.46, item 1) may require adjustment during start-up. If adjustment is required, shut off the agitation system and adjust the gland nut (fig. 5.46, item 2).

(reference to direction when seated in the operator's seat facing forward).

The agitator motors for the polyethylene tanks are held in place with a motor mount yoke (fig. 5.46, item 3). The yoke tap must extend through the motor mounting plate (fig. 5.46, item 4). This allows the motor to float with the agitator shaft.

CAUTION
DO NOT adjust the gland nut with the agitation system running.

When replacing the packing, be sure to wrap the packing clockwise on the agitator shaft

NOTE:
Damage will occur to the agitator system if the motor mounting yoke is not properly installed in the motor mounting plate.

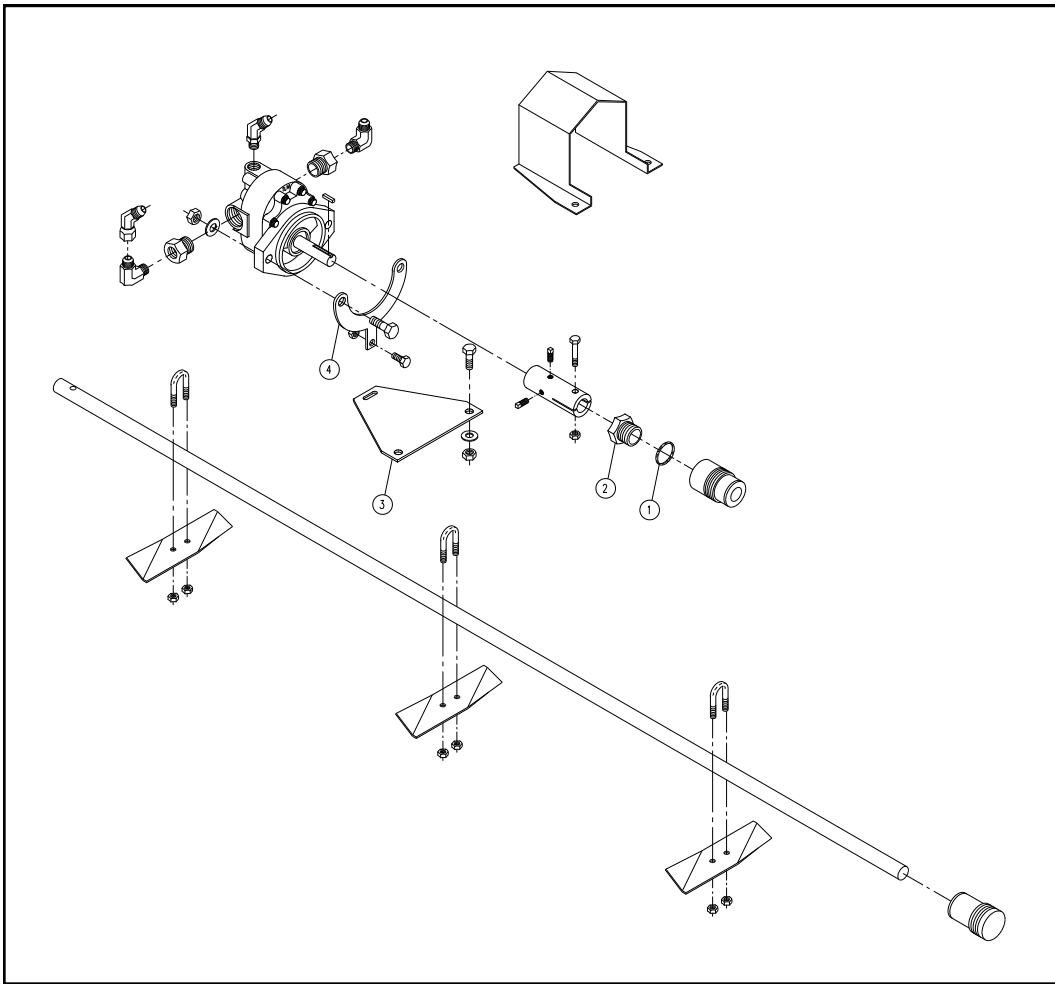
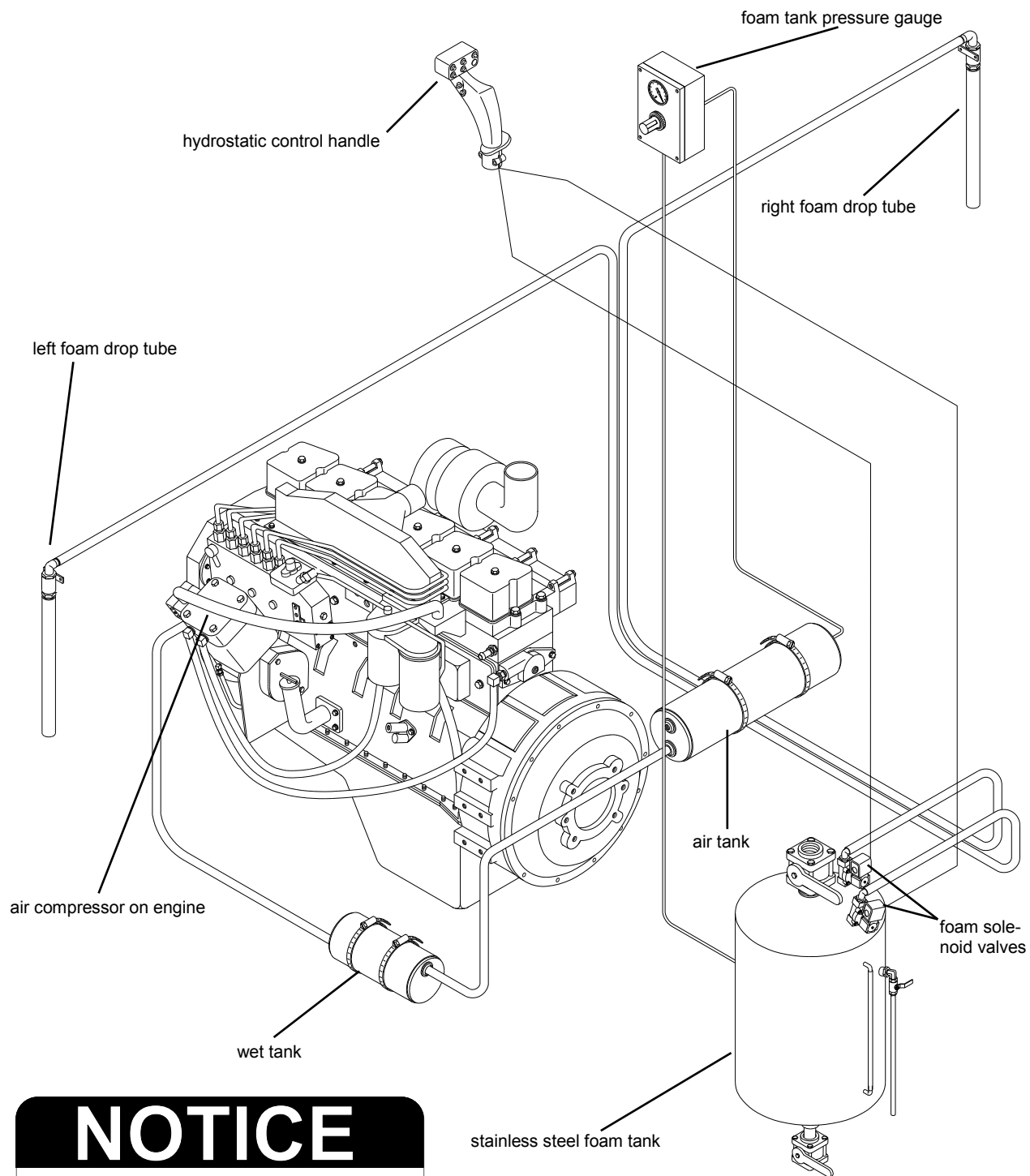

FIG 5.46

V. OPERATING INFORMATION

FOAM MARKER SYSTEM



NOTICE

DRAIN WET TANK DAILY TO REMOVE CONTAMINATION

V. OPERATING INFORMATION

Foamer Operation



FIG 5.47

To operate the foam marking system, locate the toggle switch on the hydrostat control handle (fig. 5.47). It controls a pair of valves on the pressurized stainless steel foam tank (fig. 5.48) which force foam to the foam drop tubes on the end of each outer boom.

Push the toggle switch to the left if foam is desired from the left boom tip. Push the toggle switch to the right if foam is desired from the right boom tip. Return the toggle switch to the middle position if no foam is desired.



FIG 5.48

System pressure is indicated by a pressure gauge on the regulator which is mounted on left rear panel of engine hood (fig. 5.49). To adjust the air pressure in the foam tank, turn the knob on the regulator clockwise for more pressure, and counterclockwise for less pressure. To correctly decrease the pressure in the foam tank, you must first open either the left or right foam valve for a moment to relieve system pressure. Then adjust regulator accordingly. For maintenance of the foam marker system see page 109.



FIG 5.49

V. OPERATING INFORMATION

Filling Foam Marker System

CAUTION

Before performing any service or refilling of the foam marker, shut the engine off and relieve system pressure from the tank.

WARNING

DO NOT stand directly over or in front of valves when opening.

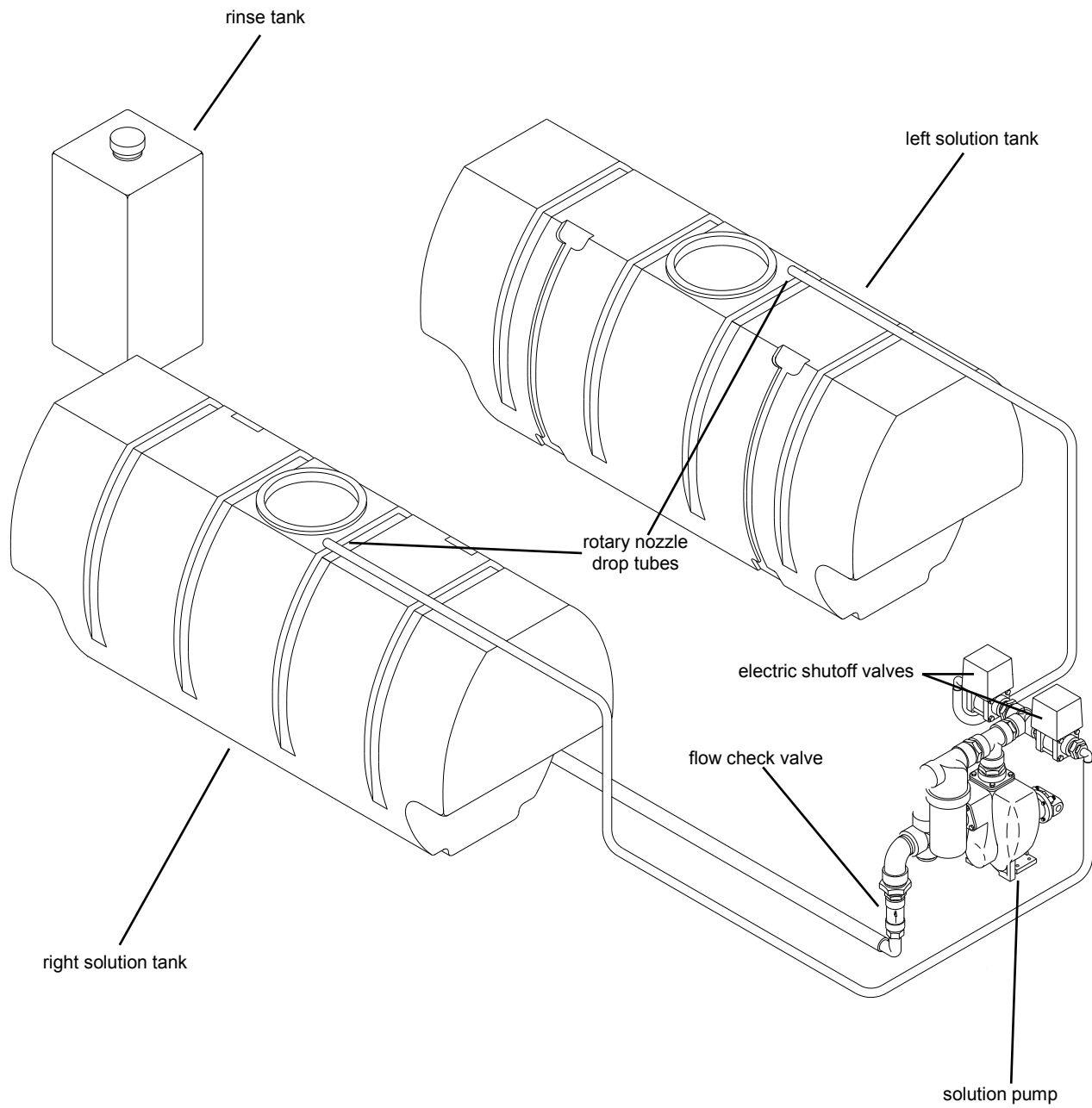

FIG 5.50

Relieve pressure from the foam tank by opening the 1/4" ball valve on the side of the foam tank (fig 5.50, item 2). Close the ball valve after pressure is relieved. Open the top 2" ball valve (fig. 5.50, item 1). Add water to the tank, leaving enough room for the foam concentrate. Next add the foam concentrate according to the label on the container. After filling is complete, close the 2" ball valve on top of the tank. Start the sprayer's engine and adjust the air pressure accordingly.

V. OPERATING INFORMATION

RINSE SYSTEM



V. OPERATING INFORMATION

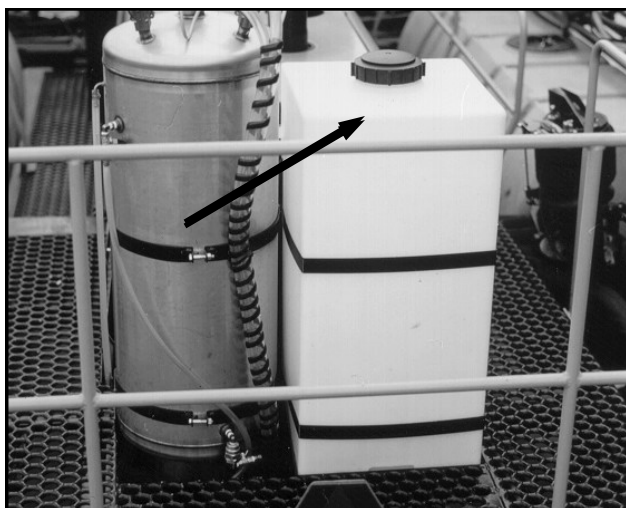

FIG 5.51



FIG 5.52

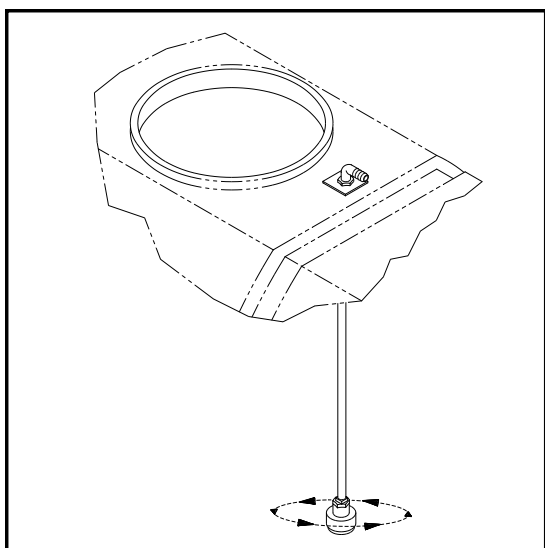

FIG 5.53

The Hagie DTS 10 comes standard with a rinse system for flushing the spray system (tanks, solution pump, and booms). The rinse tank, located on the rear of the machine (fig. 5.51), has a holding capacity of 55 gallons.

Rinse solution flows from the rinse tank to the solution pump. The rinse passes through a flow-check valve (fig. 5.52). The valve keeps the rinse line clean from spray solution when the rinse system is idle. The solution pump pumps the rinse through a rotary nozzle into either solution tank (fig. 5.53).

Refer to chemical manufacturer's guide for types of cleaning solution combinations (plain water, cleaning agents, etc.). See the next page for operation of the rinse system.

NOTE:

Select a safe area to rinse spray system and clean sprayer where the chemicals will not drift off to contaminate people, animals, vegetation, or water supply.

V. OPERATING INFORMATION

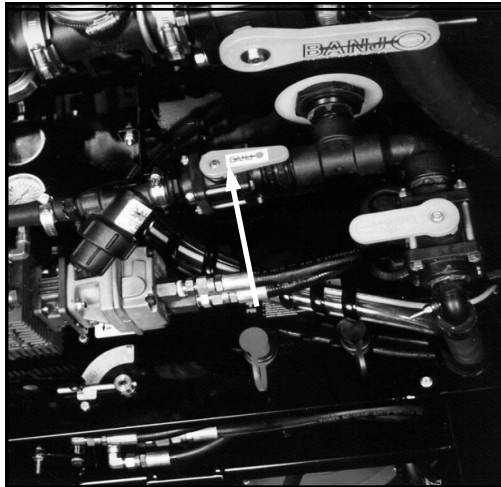

FIG 5.54

Rinse System Operation

To activate the rinse system after the solution tanks are empty:

1. If equipped with pressure washing system option, close rinse supply valve to washer pump (fig. 5.54) Close the solution tank shutoff valves (see page 53).
2. Solution pump switch should be in the “ON” position (see page 50).
3. Turn on spray system monitor (fig. 5.55). Turn the rate switch to the “MANUAL” position. Using the flow increase/decrease lever, increase solution pressure to maximum PSI. (Do not exceed 150 PSI).
4. Locate the rinse switch on the console in the cab (fig. 5.56). To rinse the right tank, depress the switch to the “RIGHT” position. To rinse the left tank, depress the switch to the “LEFT” position.
5. When finished rinsing the solution tanks, return rinse switch back to the neutral “OFF” position.
6. To rinse the booms, open the solution tank shutoff valves (see page 53), turn on the “floor” solution switch (see page 51), and open the boom solution valves (see page 43).
7. Adjust the flow control lever on the monitor to maximum solution pressure according to the solution pressure gauge.
8. When finished rinsing the booms, turn the spraying system off (including solution pump switch, monitor, boom solution valves, and “floor” solution switch).
9. Be sure to close the rinse tank valve before refilling.

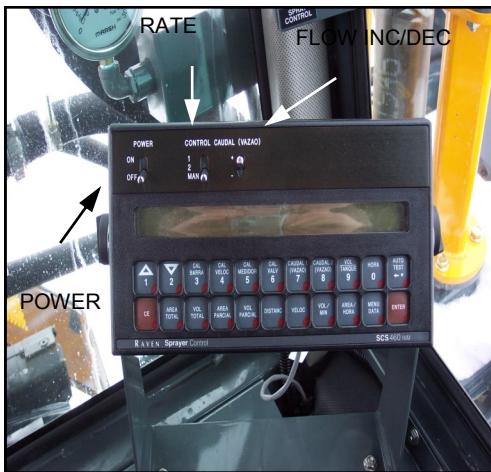

FIG 5.55



FIG 5.56

V. OPERATING INFORMATION

PRESSURE WASHING SYSTEM

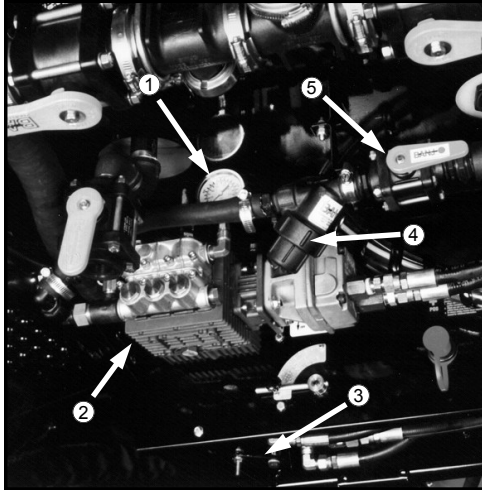

FIG 5.57

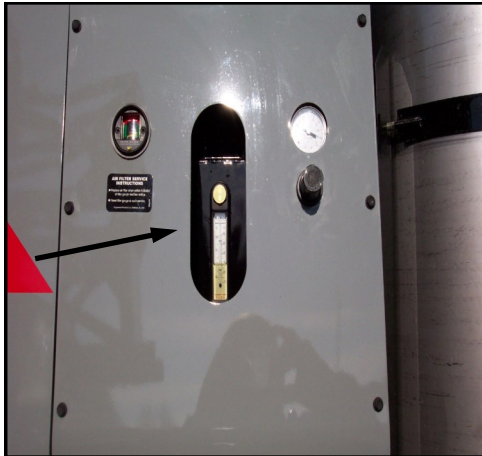

FIG 5.58



FIG 5.59

OPERATING – To operate the pressure washing system, leave the engine running between 1000 and 1200 RPM. Turn the parking brake on (see page 30). The rinse supply valve for the pressure washer (fig. 5.57, item 5) may remain open unless operating the solution tank rinse system, then you should close it as you open the rinse tank valve (see page 62). Activate the pressure washing pump (fig. 5.57, item 2) with valve handle in hydraulic sight gauge window (fig 5.58). The pressure washer “ON/OFF” handle has only approximately one half inch of travel.

DO NOT operate the pressure washing system while any other system is engaged, i.e. solution pump, hydraulic tread adjust, hydrostatic drive, etc. DO NOT allow the pump to run dry.

NOTE:

In event of emergency, pump may be turned off from underneath the machine by pushing upward on the hydraulic flow divider shaft (fig. 5.57, item 3).

The spray wand is located between the foam tank and the rinse tank (fig. 5.59). Spray pressure is indicated by the gauge mounted above the pressure pump (fig. 5.57, item 1).

MAINTENANCE – Remove and inspect in-line filter (fig. 5.57, item 4) occasionally and clean it as required.

NOTE:

For further information regarding operation and maintenance of the pressure washing system, refer to your HYPRO® pump’s owner’s manual.

V. OPERATING INFORMATION

LIGHTS

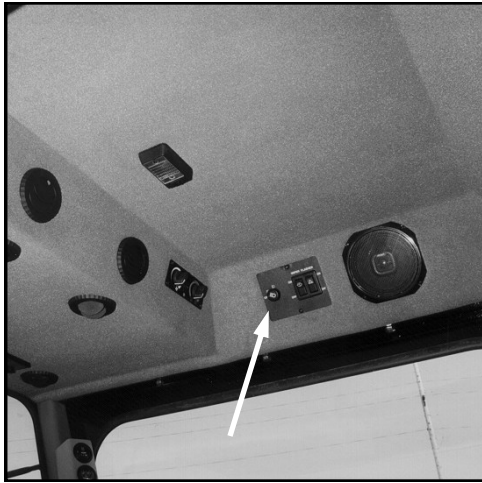

FIG 5.60

HIGHWAY LIGHTS - Mounted in the center of each front tank shield (two total) above the tires is a halogen driving lamp (fig. 5.62). Use these lights when traveling on a public road at night. Turn them on by rotating the light switch (fig. 5.60) clockwise to the first “ON” position (fig. 5.61B).

FIELD LIGHTS - The front of the cab houses four halogen field lamps (fig. 5.63). Use these lights when operating in a field after dark. Turn them on by rotating the light switch clockwise to the second “ON” position (fig. 5.61C). Turn them off when entering a public roadway.

The ignition key does not have to be on in order to operate the highway or field lights, but extended use without the engine operating to charge the battery is not recommended.

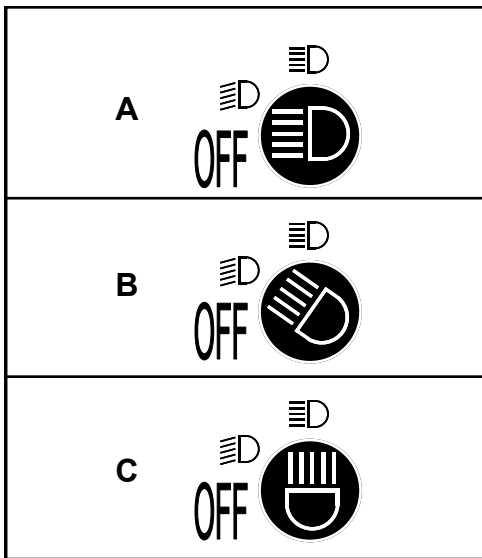

FIG 5.61



FIG 5.62



FIG 5.63

V. OPERATING INFORMATION



FIG 5.64

Work Lights

For additional lighting to the side and rear, locate the “WORK LIGHT” switch and turn it on (fig. 5.64). This will activate a pair of halogen lamps attached to the transom mount which direct light down each unfolded boom (fig. 5.65). It also activates a pair mounted above the back window of the cab lighting up the rear of the machine (fig. 5.66).

The ignition key does not have to be on in order to operate the work lights, but extended use without the engine operating to charge the battery is not recommended.



FIG 5.65

Interior Lighting

Interior lighting is provided by a ceiling mounted dome light (fig. 5.67). The ignition key must be in the “OPERATING” or “ACCESSORY” position for the interior light to operate.



FIG 5.67

V. OPERATING INFORMATION



FIG 5.68

Turn Signals

To activate the front (fig. 5.70) and rear turning signals (fig. 5.71, item 2), move the turn signal lever (fig. 5.68) up to turn right and down to turn left. Steering column-mounted turn signal indicators will correspondingly flash when either side of the turn signals is activated. The turn signal lever is not a self-centering switch; you must return it to the “OFF” position by hand after completing your turn.



FIG 5.69

Hazard/Warning Lights

To activate the flashing hazard/warning lights (fig. 5.70 & 5.71, item 1), depress the “FLASHER” switch to the “ON” position (fig. 5.69). Activate the hazard/warning lights anytime traveling on a public road, day or night, unless prohibited by law.

Running Lights

Activating the highway or field lights (see page 64) will also turn on the “RED” running lights on the rear of the machine (fig. 5.71, item 2).



FIG 5.70



FIG 5.71

V. OPERATING INFORMATION

HAGIE DTS 10 CAB



FIG 5.72

Emergency Exit.....	68
Climate Controls	69
Windshield Wiper/Washer	70
Fuel Tank Selector.....	70
Instrumentation	72
Air Suspended Seat.....	69
Steering Column	73
Auxiliary Power Supplies	74

V. OPERATING INFORMATION



FIG 5.73



FIG 5.74

Emergency Exit

Any cab glass may be broken in the event that an emergency exit is required.

1. Grasp the tool for breaking window next to the emergency exit decal (fig. 5.73) shield eyes place on glass and push (fig. 5.74) and (5.75).
2. Push window outward until clear of window opening.
3. Climb out through window and away from hazardous situation.



FIG 5.75

V. OPERATING INFORMATION

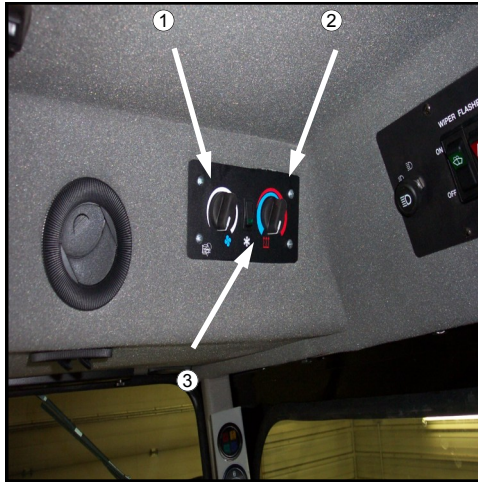

FIG 5.76



FIG 5.77



A

FIG 5.78

B

Climate Controls

ADJUSTING FAN BLOWER SPEED - Fan blower speed is controlled by the left rotary dial on the cab climate control panel (fig. 5.76, item 1). The fan blower speed is a continuously variable adjustment. To increase fan speed, rotate fan blower dial clockwise. To reduce fan speed, rotate fan blower dial counterclockwise. To shut fan blower off, rotate fan blower dial all the way counterclockwise.

ADJUSTING TEMPERATURE SETTING - Forced air temperature adjustments are controlled by the right rotary dial on the cab climate control panel (fig. 5.76, item 2). Temperature control is a continuously variable adjustment. To increase forced air temperature, rotate temperature dial clockwise. To decrease forced air temperature, rotate temperature dial counterclockwise.

OPERATING AIR CONDITIONING - To activate the air conditioner, depress the air conditioning switch (fig. 5.76, item 3). Adjust fan speed and temperature accordingly.

ADJUSTING VENTS - Air vents may be adjusted by rotating them for desired direction (fig. 5.77) or individually turned on or off with the directional fins (fig. 5.78).

SERVICING A/C SYSTEM - See page 91.

V. OPERATING INFORMATION



FIG 5.79

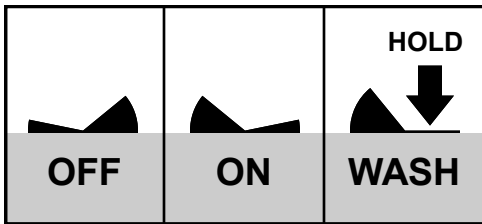

FIG 5.80

Windshield Wiper/Washer

To turn the windshield wiper on, locate the windshield wiper/washer switch on the right-hand side of the head liner (fig. 5.79). Depress the switch to the “ON” position. The wiper will continue to operate until the switch is returned to the “OFF” position.

To activate the windshield washer pump, depress the windshield wiper/washer switch and hold the switch down (fig. 5.80) until the desired amount of washing solution has been applied and then release the switch. Turn the wiper switch to the “OFF” position when the washing solution has been completely wiped away.

Fuel Tank Selector

To draw engine fuel from the right fuel tank, depress the fuel selector switch (fig. 5.81) to the “RIGHT” position. To switch to the left tank, depress the fuel selector switch to the “LEFT” position. You may operate from either tank until the “YELLOW” low level indicator light illuminates. Then you must either switch to the other tank or refuel.



FIG 5.81

V. OPERATING INFORMATION

Air Suspended Seat

- 1 - **Seat Cushion Adjustment.** Rotate knob to desired cushion position.
- 2 - **Height Adjustment.** Pull knob out to lower seat. Push knob in to raise seat.
- 3 - **Lateral Isolator.** Lift lever to engage lateral isolator. Push lever down for lock-out.
- 4 - **Ride Firmness Adjustment.** Rotate knob counterclockwise for firm ride, clockwise for soft ride. For average ride, rotate knob to midpoint of travel.
- 5 - **Fore-Aft Adjustment.** Pull lever out and move seat forward or rearward to desired position.
- 6 - **Fore-Aft Isolator.** Lift lever to engage fore-aft isolator. Push lever down for lock-out.
- 7 - **Backrest Adjustment.** Lift lever to stop and lean rearward or forward to adjust backrest position.
- 8 - **Armrest Tilt Adjustment.** Turn counterclockwise to lower tilt, clockwise to raise tilt.
- 9 - **Lumbar adjustment.** Rotate knob clockwise to increase lumbar support, counterclockwise to decrease support.

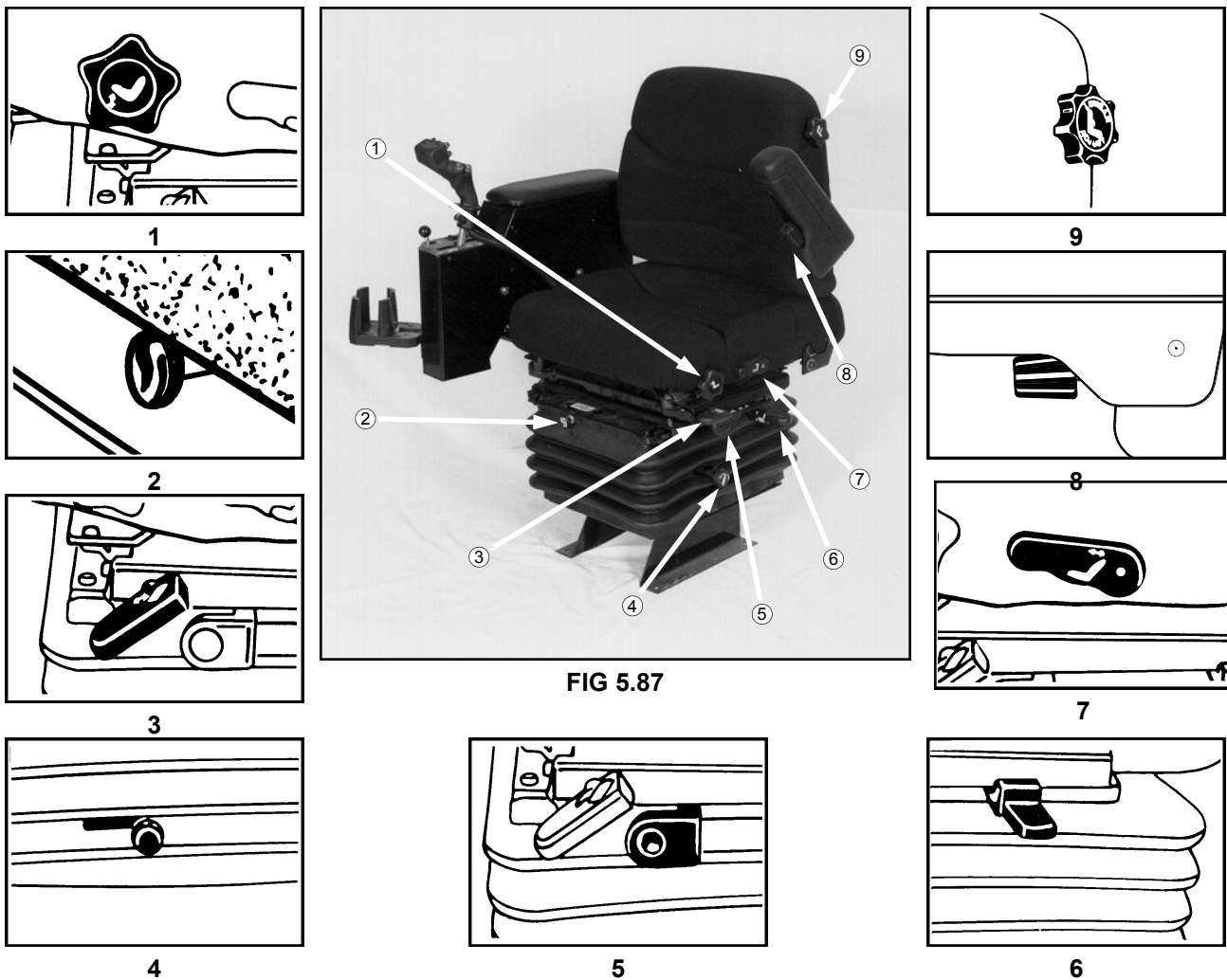

FIG 5.87

V. OPERATING INFORMATION

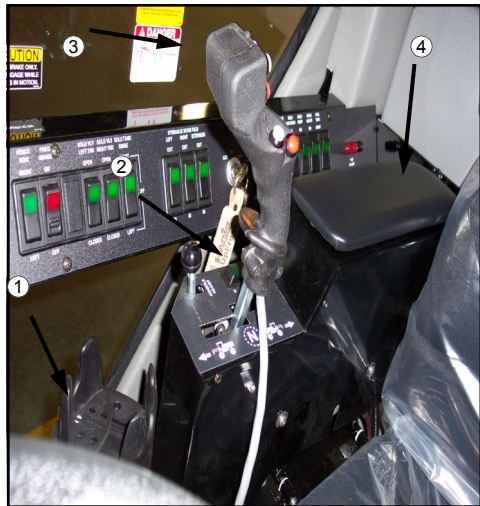

FIG 5.88

Seat-Mounted Console

The seat-mounted console/armrest houses the hydrostatic drive control lever (with boom lift and level controls and foam system operation switch) (fig. 5.88, item 3), speed switch (fig. 5.88, item 2), operating panel for the hydraulic tread adjust (fig. 5.88, item 4), small storage tray (fig. 5.88, item 4), and adjustable drink holder (fig. 5.88, item 1).

To adjust the height of the console, pull the adjustment lever (fig. 5.89) back as you move the console either up or down. When the console is at the desired height, release the adjustment lever (fig. 5.90).

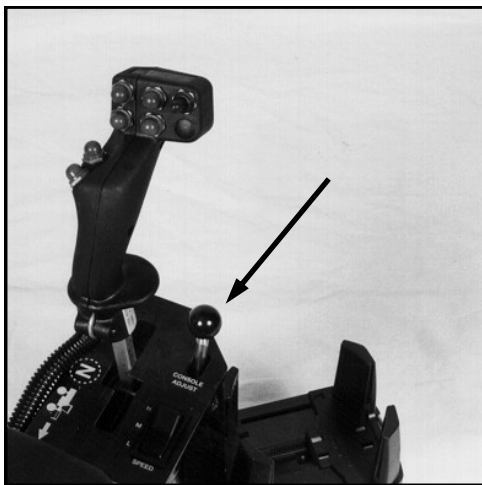

FIG 5.89



FIG 5.90

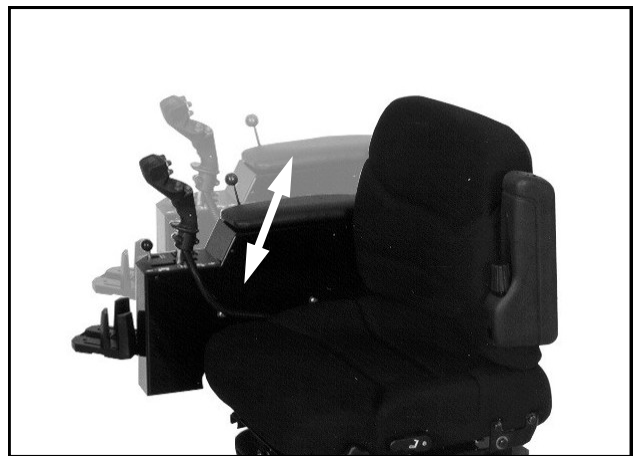

FIG 5.91

V. OPERATING INFORMATION



FIG 5.92

Steering Column

The Hagie DTS 10's steering column has two places for driver comfort adjustment. To adjust the upper tilt, locate the tilt lock lever on the right-hand side of the steering column (fig. 5.92); rotate the lever counterclockwise to release steering column tilt lock. Move steering column to desired position and rotate lever clockwise to lock column in place.

To ease cab exit and entry, the entire steering column tilts out of the driver's way. To operate the column base tilt, locate the foot pedal at the base of the steering column (fig. 5.94); push down on the foot pedal to release the column base lock. Pull or push the column to the desired position and release the foot pedal to re-lock the column base.



FIG 5.93

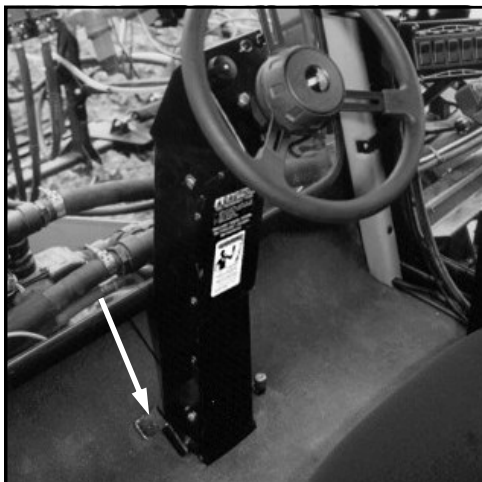

FIG 5.94



FIG 5.95

V. OPERATING INFORMATION



FIG 5.96

Auxiliary Power Supplies

The Hagie DTS 10 has two separate auxiliary power supplies in the cab for powering 12 volt accessories. They are both “hot” regardless of ignition key position. Turn the accessory off if the engine is not running for an extended period of time.

SWITCH PANEL “BINDING POST” TYPE - The binding post power supply is located to the right of the parking brake switch (fig. 5.96). Binding post power supply is protected by a 30 AMP circuit breaker (see page 100).

STORAGE CONSOLE “CIGARETTE LIGHTER” TYPE - The cigarette lighter power point is located to the left of the operator’s seat on the side of the floor-mounted storage console (fig. 5.97). Replace the insulated plug when not in use. Cigarette lighter power supply is protected by a 30 AMP circuit breaker (see page 100).



FIG 5.97

Roof Panel Access

See page 104 for information on accessing the area under the cab roof panel for service (fig. 5.98).



FIG 5.98

VI. CALIBRATION

CALIBRATING YOUR SPRAYING SYSTEM

It is important to apply chemicals as recommended by the manufacturers of the product. In order to do so, the spraying system must be properly calibrated. Determine the speed at which the sprayer will be driven while applying chemicals.

To select the best speed, consider the lay of the land, the condition of the soil, the type of crops, the height of the crops, etc. Select the nozzle spacing (distance between each nozzle on the spray boom) best suited for the intended spraying job.

For help in determining the nozzle spacing and height of boom, refer to the spray product catalog that accompanies this manual. There are several types and sizes of nozzles. Select (as recommended by the catalog) and install the type and size of nozzles best suited for the intended spraying job. The type and size of nozzles selected will depend upon the speed the sprayer will travel, the nozzle spacing, and the number of gallons one intends to apply per acre.

IMPORTANT:

**DO NOT ADD CHEMICALS UNTIL
CALIBRATION IS COMPLETED.**

VERIFYING CALIBRATION

Check with manufacturer on recommended spray pressure. To test your system, fill the solution tanks with clean water. Do not add chemicals until calibrated and verified.

With brakes applied, start the engine of the sprayer; throttle the engine to operating speed and remain parked. Turn on all boom section solution switches. Make sure there are no leaks and that all nozzles are spraying a desirable pattern. Continue spraying in the stationary position for at least 10 minutes for proper warm-up of the sprayer and its system. Catch one nozzle's spray for one minute in an adequately sized and marked container.

VI. CALIBRATION

The measured flow rate should be the same as the flow rate shown on the chart below. The chart shows rate of discharge in gallons per minute for various field speeds and row spacings to apply 10 gallons per acre.*

If the measured flow rate is not the same as that on the calibration tube's chart, consult the

trouble shooting guide in the service manual for the spray system's monitor.

All nozzles should be spraying at about the same flow rate. If one drives the sprayer at the proper speed and maintains the right pressure setting while spraying, the desired gallons per acre will be applied.

RATE OF DISCHARGE

Tip Spacing	GALLONS PER MINUTE**				
	4 mph	5 mph	6 mph	7 mph	8 mph
15"	.101	.126	.151	.176	.202
16"	.107	.133	.160	.187	.214
17"	.114	.142	.171	.199	.228
18"	.121	.151	.181	.211	.242
19"	.127	.158	.190	.222	.254
20"	.134	.167	.201	.234	.268
30"	.201	.251	.303	.351	.403
36"	.242	.302	.363	.423	.484
38"	.255	.318	.382	.446	.510
40"	.269	.336	.403	.470	.538

* Divide by 10 to get 1 gallon per acre rate

** At a rate of 10 gallons per acre

VII. TRANSPORTING

A. DRIVING

When driving the sprayer on a public road or highway, drive carefully and follow these steps.

1. Always have the booms in the folded position and cradled when driving or transporting. Adjusting level cylinders, so the full weight of the boom rests in the cradle.
2. Flashing hazard/warning lights have been placed on the sprayer to warn other drivers.
3. A SMV (Slow Moving Vehicle) emblem has been mounted on the sprayer to warn other drivers that one is moving slowly. Keep it properly displayed, unless prohibited by law.
4. Know and obey all state laws for driving farm equipment on a public road or highway.
5. Adjust the sprayer's speed to suit the conditions.
6. Slow down and use turn signals before turning.
7. Pull over to side of road before stopping.
8. Keep a proper lookout, and maintain control of the sprayer.
9. Do not drive under trees, bridges, wires, or other obstructions unless there is clearance.
10. Use extra care before entering or leaving a public road or highway.
11. Do not drive machine loaded on road or highway.



Warning: When transporting the sprayer observe the following safety items to avoid serious injury or death.

- Check for overhead clearance before driving under any overhead obstructions.
- Contact with power lines can result in serious injury or death.



Caution: When transporting the sprayer observe the following safety item to avoid injury or equipment damage.

- Do not transport machine without booms folded and in cradle.

VII. TRANSPORTING

B. TRAILERING:

NOTE:

Extra care should be taken when loading the sprayer onto any trailer. Consider whether it is best to back the sprayer on or drive the sprayer forward.

1. Loading:



WARNING

**Never load or unload a sprayer
with solution in the tanks.**

NOTE:

Be sure to read and understand the trailer's owner and operator manual. Hitch the trailer to the pulling vehicle as shown in the trailer's owner and operator manual.

When moving the sprayer onto a trailer, follow these steps completely:

- a. Pull the trailer to flat ground. Apply the pulling vehicle's parking brake and turn off the engine. Use tire chocks to keep the trailer from moving.
- b. Fold in the sprayer's booms and lower to the boom cradle.
- c. Lower the trailer ramps and set the ramp spacing for the sprayer's tread setting.
- d. Get someone to help guide you onto the trailer. Keep everyone a safe distance from the sprayer.

VII. TRANSPORTING

WARNING

Stopping the sprayer on the trailer loading ramps may result in sprayer tip-over.

- e. Allow enough room between the sprayer and the pulling vehicle for turning.
- f. Secure the sprayer to the trailer. See the trailer's owner and operator manual for instructions.
- g. Cover or remove the SMV (Slow Moving Vehicle) emblem when traveling over 25 miles per hour.

NOTE:

The loaded height and width of the trailer must conform to the law of the state in which it is being used.

2. Unloading:

When moving the sprayer off of a trailer, follow these steps completely:

- a. Pull the trailer to flat ground. Apply the pulling vehicle's parking brake and turn off the engine. Use tire chocks to keep the trailer from moving.
- b. Lower the trailer ramps and set ramp spacing for the sprayer's tread setting.
- c. Release securing restraints carefully.
- d. Get someone to help guide off the trailer. Keep everyone a safe distance from the sprayer.
- e. Uncover or replace the SMV (Slow Moving Vehicle) emblem.

NOTE:

It is not recommended that the Model DTS10 be towed.

VIII. SERVICE AND MAINTENANCE

PAGE NO	Service Point	C L E A N	C H A N G E	C H E C K	G R E A S E	D R A I N
77	ENGINE OIL		A	DAILY		
79	RADIATOR COOLANT LEVEL			DAILY		
80	COOLANT OVERFLOW RESERVOIR LEVEL			DAILY		
79	COOLANT CONCENTRATION		AS REQ	500 HRS*		
83	RADIATOR GRILLE SCREEN	DAILY				
95	ENGINE DRIVE BELT		AS REQ	DAILY		
95	A/C COMPRESSOR BELT		AS REQ	250 HRS		
81	A/C COMPRESSOR		B			
84	A/C DRYER		AS REQ			
85	FUEL FILTER (WATER SEPERATOR)		500 HRS*			DAILY
85	IN-LINE FUEL STRAINER		AS REQ			
82	AIR INTAKE FILTER	NOT REC	C			
82	FILTER MINDER®		D	DAILY		
77	HYDRAULIC RESERVOIR OIL LEVEL		500HRS**	DAILY		
83	HYDRAULIC SUCTION FILTER		E			
83	HYDROSTATIC CHARGE PRESSURE FILTER		E			
96	NEUTRAL SETTING OF HYDROSTATIC PUMPS		AS REQ	DAILY		
84	HIGH-PRESSURE IN-LINE FILTER (TREAD ADJUST VLVS)	AS REQ				
84	HIGH-PRESSURE IN-LINE FILTER (BOOM CTRL VALVES)	AS REQ				
84	SOLUTION LINE STRAINER	AS REQ		DAILY		
78	TORQUE HUB® OIL LEVEL		F	DAILY		
87	TORQUE HUB® SEAL BOOT ZERK (4 PLACES - 1 EACH)				50 HRS	
102	WET TANK					DAILY
86	LEG BEARING ZERKS (12 PLACES - 3 EACH)				DAILY	
89	BOOM/BREAKAWAY ZERKS (60 12-6EA OR 80/90 14-7EA)				AS REQ	
88	TRANSOM, LIFT ARM, AND LIFT CYL ZERKS (16 PLACES)				25 HRS	
87	TREAD ADJUST SLIDE-PATH ON MAINFRAME				AS REQ	
98	LEG MOUNT BOLT TORQUE			DAILY		
90-91	BATTERY	100 HRS	AS REQ	DAILY		
97	LUG NUT TORQUE			G		
103	TIRE PRESSURE			50 HRS		
85	FRESH AIR CAB FILTER	AS REQ*	AS REQ			
85	CHARCOAL CAB FILTER		AS REQ			
85	RECIRCULATION FILTER	AS REQ				
92-93	FUSES/CIRCUIT BREAKERS		AS REQ			
102	SPRAY NOZZLE DIAPHRAGMS & SPRAY TIPS			500HRS**		

*OR YEARLY, WHICHEVER COMES FIRST; OR AS REQUIRED
 **OR AT THE BEGINNING OF THE SEASON, WHICHEVER
 COMES FIRST; OR AS REQUIRED
 NOTE A: SEE ENGINE MANUFACTURER'S HAND BOOK
 NOTE B: CHARGE AS REQ; USE PROPER EQUIPMENT

NOTE C: FOLLOW FILTER MINDER READINGS
 NOTE D: RESET EACH TIME YOU SERVICE AIR FILTER
 NOTE E: 1ST 50 HRS, THEN 250 HRS THEREAFTER
 NOTE F: 1ST 50 HRS, THEN 100 HRS THEN YEARLY
 NOTE G: IMMEDIATELY, THEN 50 HRS THEREAFTER

VIII. SERVICE AND MAINTENANCE

SERVICE INTERVALS

Initial checks after receiving machine

IMMEDIATELY  then 

- 1) Check lug nut torque, then every 50 hours (page 104)

FIRST 50 HOURS  then 

- 1) Change Torque Hub[®] oil, then every 100 hours (page 85)
- 2) Change hydrostatic charge pressure filter, then every 250 hours (page 90)
- 3) Change hydraulic suction filter, then every 250 hours (page 90)

Daily

- 1) Check engine oil (page 84)
- 2) Drain fuel filter (water separator) (page 92)
- 3) Check radiator coolant level (page 87)
- 4) Check radiator coolant overflow reservoir level (page 87)
- 5) Check engine drive belt (page 102)
- 6) Check Filter Minder[®] (page 89)
- 7) Check hydraulic oil reservoir level (page 84)
- 8) Check for neutral setting of hydrostatic pumps (page 103)
- 9) Check solution line strainer (page 91)
- 10) Drain wet tank (page 109)
- 11) Grease all leg bearings (page 93)
- 12) Check leg mount bolts (page 105)
- 13) Check battery (page 91)

Every Other Day

- 1) Grease transom, lift arm, and lift cylinder zerk (page 95)

VIII. SERVICE AND MAINTENANCE

▶ SERVICE INTERVALS

As Required



- 1) Change coolant concentration (page 86)
- 2) Clean radiator grille screens (page 90)
- 3) Change engine drive belt (page 102)
- 4) Change A/C compressor belt (page 102)
- 5) Change A/C dryer (page 91)
- 6) Charge A/C compressor (page 88)
- 7) Change fuel filter (water separator) (page 92)
- 8) Change in-line fuel pre-filter (page 92)
- 9) Change hydraulic reservoir oil (84)
- 10) Adjust neutral setting of hydrostatic pumps (page 103)
- 11) Clean high-pressure in-line filter on boom control stack valve (page 91)
- 12) Clean solution line strainer (page 91)
- 13) Grease all boom folding and breakaway zerks (page 96)
- 14) Grease tread adjust slide path on mainframe (page 94)
- 15) Change battery (page 97)
- 16) Clean fresh air intake cab filter (page 92)
- 17) Change charcoal cab filter (page 92)
- 18) Clean recirculating cab filter (page 92)
- 19) Replace fuses and circuit breakers (page 99-101)

VIII. SERVICE AND MAINTENANCE

Every 25 HOURS



- 1) Grease transom, lift arm, and lift cylinder zerks (page 95)

Every 50 HOURS



- 1) Check tire pressure (page 110)
- 2) Check lug nut torque (page 104)
- 3) Grease Torque Hub[®] seal boot (page 94)

Every 100 HOURS



- 1) Check Torque Hub[®] oil level (page 85)
- 2) Clean battery (page 97)

Every 250 HOURS



- 1) Check A/C compressor belt (page 102)
- 2) Change hydrostatic charge pressure filter (page 90)
- 3) Change hydraulic suction filter (page 90)

Every 500 HOURS or 1 Year

- 1) Check coolant concentration (page 86)
- 2) Change fuel filter (water separator) (page 92)
- 3) Change hydraulic reservoir oil (page 84)
- 4) Change Torque Hub[®] oil (page 85)
- 5) Check spray nozzle diaphragms and spray tips (page 109)

VIII. SERVICE AND MAINTENANCE

FLUIDS

Engine oil

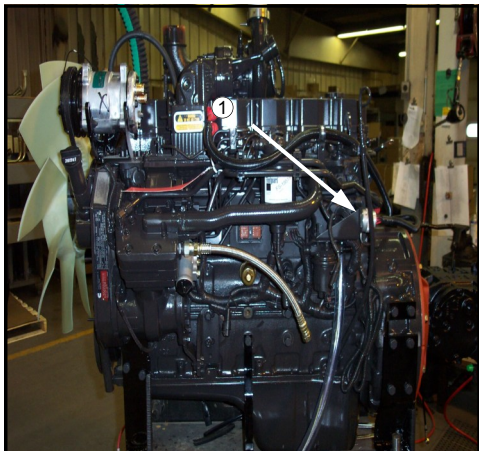

FIG 8.1

OIL LEVEL - The engine oil level dipstick is located on the left-hand side of the engine (fig. 8.1, item 1). Never operate the engine with the oil level below the “L” (low) mark or above the “H” (high) mark. Wait at least five minutes after shutting off the engine to check the oil level; this allows time for the oil to drain to the oil pan. Check the engine oil level daily.

CAPACITY - Low to high mark capacity is 2.0 quarts. Engine oil pan capacity is 15 quarts. Refer to Engine Operation and Maintenance manual for maintenance schedule.

NOTE:

The engine must be level when checking the oil level to make sure the measurement is correct.

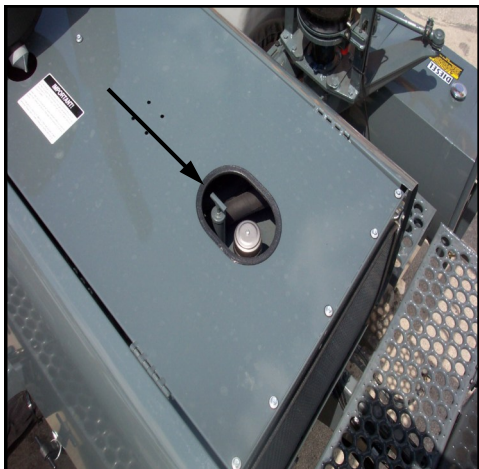

FIG 8.2

Hydraulic Oil Reservoir

OIL LEVEL - Check the hydraulic oil level in the reservoir using the dipstick (fig. 8.2) or the sight gauge on the left-hand side of the tank (fig 8.2, item 1) daily. Add just enough fluid so the level reaches the bottom tip of the dipstick or level is in the center of the sight gauge (fig. 8.3). Always check the hydraulic oil level when it is cool. Hydraulic oil will expand when heated in a system and measuring the reservoir by these levels allows for expansion.

TYPE - Premium hydraulic fluids containing high quality rust/oxidation/and foam inhibitors are required. Hydraulic oil must conform to one of the following types: anti-wear hydraulic oil, type F automatic transmission fluid, or agricultural hydraulic transmission fluid. Replace the oil in the hydraulic reservoir at 500 hours or at the beginning of each spraying season, whichever comes first.



FIG 8.3

VIII. SERVICE AND MAINTENANCE

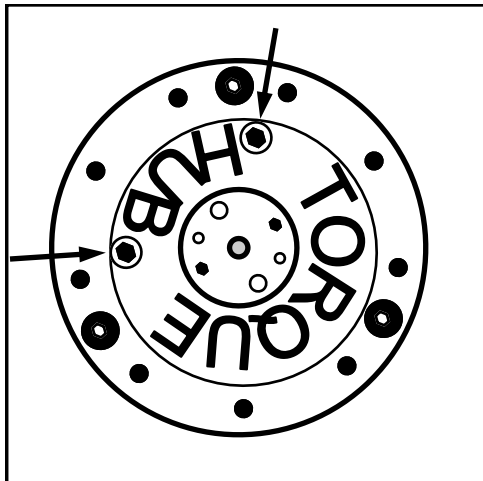

FIG 8.4



FIG 8.5

Torque Hub[®] Oil

OIL LEVEL - Each Torque Hub[®] should maintain an oil level of half full at all times. Less than that would limit lubrication, and over half full could cause overheating and damage. To check oil level, position Torque Hub[®] so one of the face plugs is positioned at 12 O'clock (fig. 8.4). The other plug will be either at 9 O'clock or 3 O'clock. Remove the lower plug: if no oil comes out, oil level is too low. Check Torque Hub[®] oil level every daily hours.

If 85-140 oil is needed, remove the top plug also and fill just until it starts to come out the lower hole. With the oil at a satisfactory level, re-install plugs.

CHANGE - The Torque Hub[®] oil should be changed after the first 50 hours of operation, preferably in a loaded condition. Subsequently, it should be changed every 100 hours after that, or once a year whichever comes first.

To change the Torque Hub[®] oil, position one of the plugs at 6 O'clock, and the other at either 3 O'clock or 9 O'clock. Remove the plugs to drain the oil. Once all of the oil is drained, position hub so plug hole is at 12 O'clock and 3 O'clock or 9 O'clock . Refill Torque Hub[®] with 85-140 oil as shown in (fig.8.5) using this method, and install plug.

GENERAL MAINTENANCE - If your sprayer is going to sit for an extended period of time, occasionally rotate the hubs by driving the sprayer forward or backward a few feet to adequately coat all internal hub parts. This will prevent rusting if moisture inadvertently entered the hub during an oil change. Failure to rotate hub and disperse oil may cause rusting and internal damage.

VIII. SERVICE AND MAINTENANCE



FIG 8.5

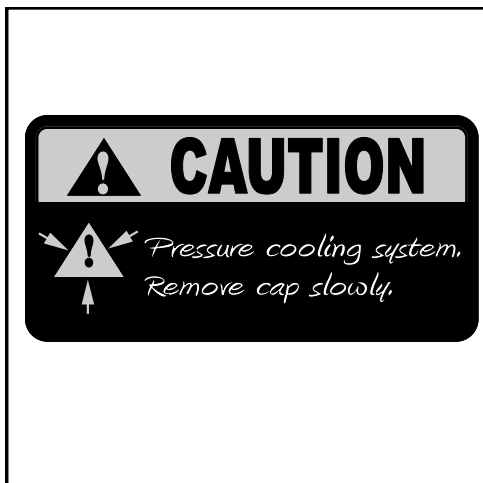

FIG 8.6

Ethylene Glycol		
40%	-23°C	-10°F
50%	-37°C	-34°F
60%	-54°C	-65°F

FIG 8.7

Cooling System

COOLANT TYPE - Your cooling system should always be sufficiently charged with an adequate mixture of antifreeze and water, regardless of the climate, in order to maintain a broad operating temperature range. Your cooling system has been factory-charged with an ethylene glycol-based antifreeze.

NOTE:

Ethylene glycol-based antifreeze and propylene glycol-based antifreeze should never be mixed.

CHECKING CONCENTRATION - The radiator cap is located immediately behind the rear of the cab (fig. 8.5). Never remove a cap from a hot engine. Always allow the engine to cool before servicing cooling system.

A 50/50 antifreeze/water mixture is a conservative mixture which allows good protection against both overheating and freezing. If a stronger antifreeze mixture is required, be sure not to exceed the engine manufacturer's guidelines for antifreeze mixing. The table in figure 8.7 gives a few examples of ethylene glycol antifreeze/water mixture protection values. Consult the engine manufacturer's handbook for further information.

Concentration should be checked every 500 hours or at the beginning of each winter, whichever comes first. It should be checked using a refractometer; "floating ball"-type density testers or hydrometers are not accurate enough for use with heavy duty diesel cooling systems.

VIII. SERVICE AND MAINTENANCE

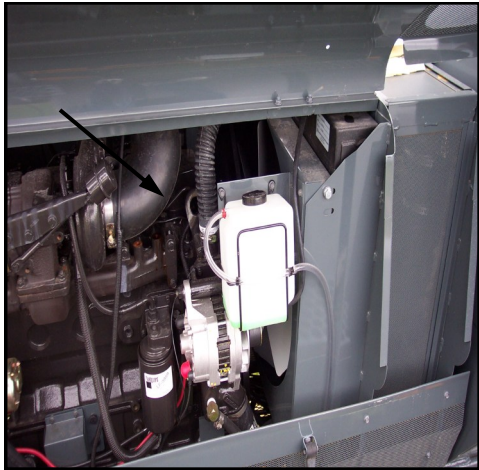

FIG 8.8

COOLANT RESERVOIR - The coolant reservoir is located under the left-hand hood toward the rear of the machine (fig. 8.8). Check its level everyday while the engine is cold. Maintain the coolant reservoir level within the normal cold range marks.

CHANGING COOLANT - Your coolant should periodically be changed to eliminate the buildup of harmful chemicals. Drain and replace the coolant every other spraying season or every 1,000 hours of operation, whichever comes first. Refill only with ethylene glycol coolant. Antifreeze should be mixed only with soft water because hard water contains minerals which break down the anti-corrosion properties of antifreeze.

Fuel

TYPE - No. 2 diesel fuel is recommended for the best economy and performance under most operating conditions. In operating conditions under 32° F, use a blend of No. 1 and No. 2 diesel fuel. The addition of No. 1 diesel fuel may cause loss of power and/or fuel economy.

STORING - See section 9 on sprayer storage.

REFILLING - Always turn off the engine and allow it to cool before refueling. Never smoke while fueling. Keep a fire extinguisher within reach while refueling.

Each tank holds 50 gallons - do not fill them completely: fuel can expand and run over. Wipe up all spilled fuel and clean with detergent and water before starting the engine.

PRIMING - If the fuel system should happen to run dry and lose its prime, refer to engine manual page 5-8 for proper priming procedures.



FIG 8.9

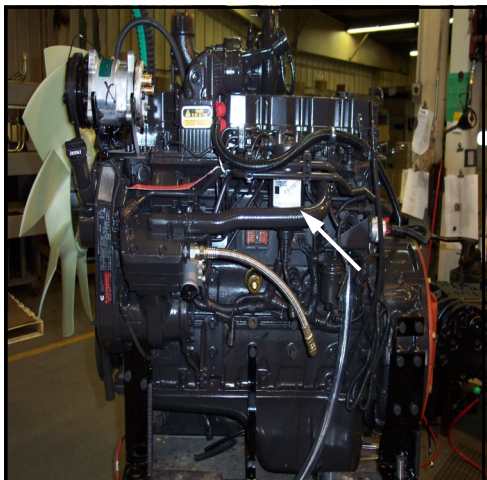

FIG 8.10

VIII. SERVICE AND MAINTENANCE

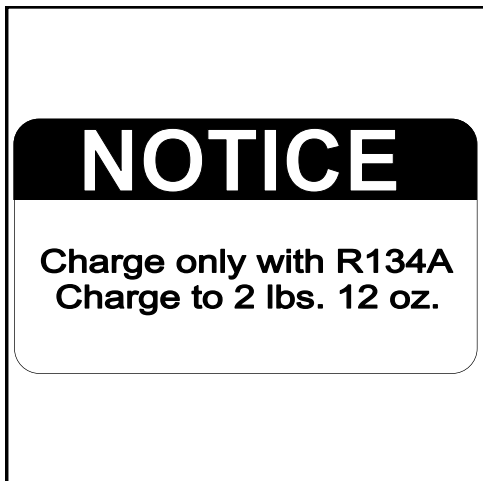

FIG 8.11

Air Conditioning

TYPE - The cab on your sprayer is equipped with a R-134a air conditioning system.

RECHARGING - Recharge it only with R-134a refrigerant. If your air conditioning system is mistakenly charged with R-12 refrigerant, serious problems, such as compressor seizure, may result. Therefore, confirm refrigerant before recharging system.

If you do not have the proper recharging equipment, it is recommended that you allow an independent service agent service your air conditioning system.

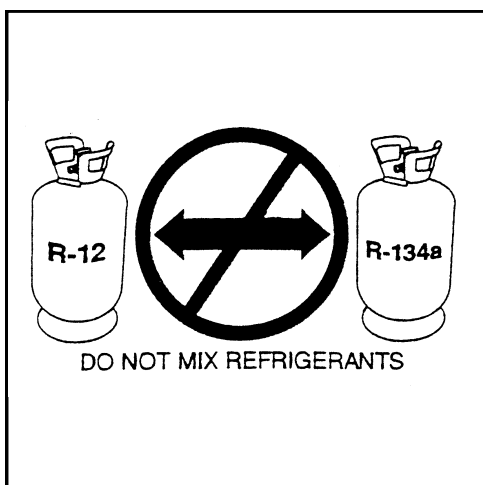

FIG 8.12

Windshield Washer Fluid

The windshield washer reservoir is located toward the front of the sprayer behind the center front shield (fig. 8.13). Check it occasionally and refill it with non-freezing automotive windshield cleaner as required.



FIG 8.13

FLUID CAPACITIES AND TYPES

Engine oil pan, including filter.....	17 quarts SAE 15W-40
Engine oil dipstick, L-H mark.....	2 quarts
Hydraulic oil reservoir	25 gallons anti-wear hydraulic oil
Torque Hub® oil level (4)	approx. 23 oz. ea. EP-90
Engine cooling system.....	10 gallons ethylene glycol
Fuel tanks (2).....	50 gallons ea. No. 1 or 2 diesel

VIII. SERVICE AND MAINTENANCE



FIG 8.14



FIG 8.15



FIG 8.16

FILTERS

Engine Air Intake

LOCATION - The engine air intake filter is accessible by lifting the left engine compartment hood (fig. 8.14).

REMOVAL - The engine air intake filter element should only be removed if it is going to be replaced. After loosening the air cleaner clamp and removing the end cap, carefully remove the filter so as to not knock any dust off the filter and into the air intake passage (fig. 8.15).

REPLACEMENT - Your sprayer is equipped with a Filter Minder[®] to notify you of filter element efficiency. Follow its guidelines for servicing. (See below.) At appropriate service time, install the new element carefully to ensure proper sealing.

CLEANING - It is not recommended to clean the air filter element. However, a clean damp cloth should be used to wipe dust and foreign material from the air cleaner housing before a new element is installed.

Filter Minder[®]

LOCATION - The Filter Minder[®] is an air restriction monitoring system that progressively and constantly indicates how much air filter capacity remains. It is mounted behind the left-hand engine compartment hood (fig. 8.16). Check its reading daily.

SERVICE - Service the air cleaner when the Filter Minder[®] reads 20" (80% of average dirt holding capacity). Reset the Filter Minder[®] to zero each time you replace the air filter element.

NOTE:

Service the air cleaner before the yellow indicator reaches the red line of the Filter Minder[®].

VIII. SERVICE AND MAINTENANCE



FIG 8.17

Grille Screens

In order to maintain maximum air flow through the engine cooling system's radiator, oil cooler, and air conditioning condenser, the cooling air intake grille screens must be inspected often and periodically removed for cleaning.

REMOVAL - The side grille screens are easily removed by sliding them up out of their housings (fig. 8.17). The top screen (fig. 8.17) and may also be removed for cleaning.

CLEANING - Compressed air will dislodge most large trash or loose dirt after the screens have been removed. Blow out the screens away from the machine. Water from a pressurized hose may also be used, or if necessary the screens may be soaked in soapy water and scrubbed with a brush.

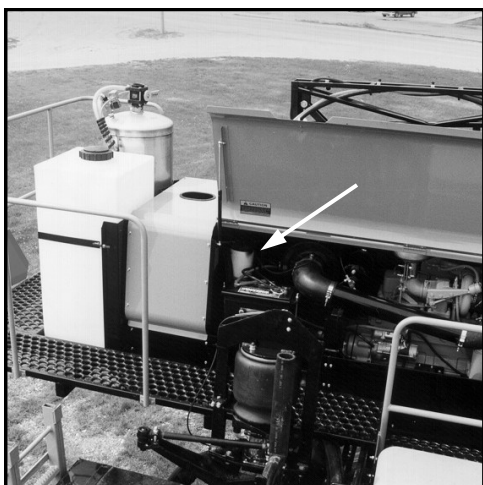

FIG 8.18

NOTE:

When cleaning cooling fins of the radiator, oil cooler, or A/C condenser with compressed air or water, be careful not to damage cooling fins which may impair cooling capabilities.

Hydraulic Suction Filter

Remove and install a new 10 Micron rated suction filter (fig. 8.18) at the end of the first 50 hours of use; subsequently, replace the filter every 250 hours, or once a year, whichever comes first.



FIG 8.19

Hydrostatic Charge Pressure Filter

Remove and install a new 4 Micron rated charge pressure filter (fig. 8.19) at the end of the first 50 hours of use; subsequently, replace the filter every 250 hours, or once a year, whichever comes first.

VIII. SERVICE AND MAINTENANCE



FIG 8.20

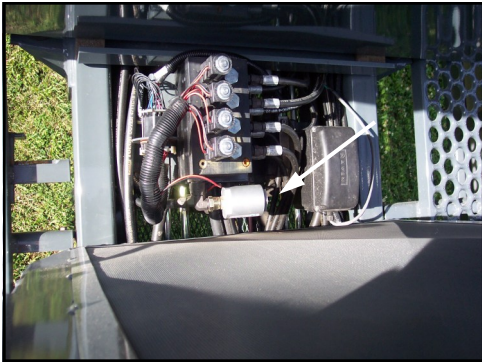

FIG 8.21

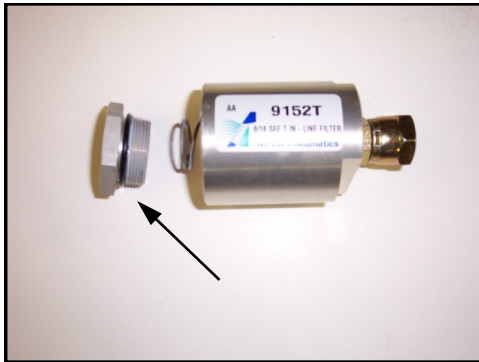

FIG 8.22



FIG 8.23

High Pressure In-line Filters

STACK VALVES - The valves on the boom control stack valve (fig. 8.20) and the valves on the tread adjust stack valve (fig. 8.21) are each protected by a 90 Micron in-line sintered bronze filter. When the filter elements are removed for cleaning, caution should be taken so the gasket is in the proper place when re-installing (fig. 8.22). Also, re-install filter paying attention to direction of flow so the end marked “OUT” is oriented correctly.

Solution Line Strainer

To help maintain consistent application rates, check the solution line strainer daily for blockage (fig. 8.23). To remove the strainer, close the tank shutoff valves. Clean the strainer screen as required. Be sure to wear the appropriate clothing while removing and cleaning the line strainer screen. Confirm the gasket is in place before re-installing the screen. Line strainers for the high pressure D250 pump are located under each solution tank. Remove and clean them in the same manner.

Air Conditioning System Dryer

The A/C system receiver/dryer (fig. 8.24) should be replaced if the A/C loop is ever opened such as replacing a compressor or condenser line, etc.

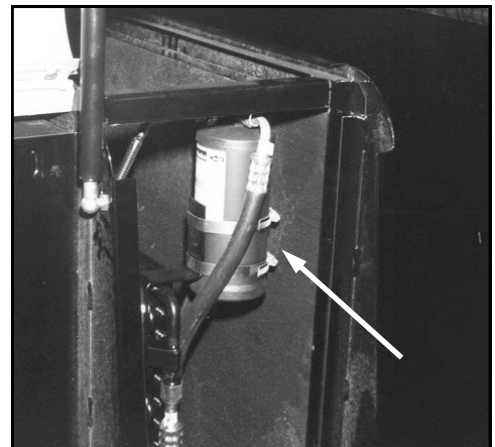

FIG 8.24

VIII. SERVICE AND MAINTENANCE

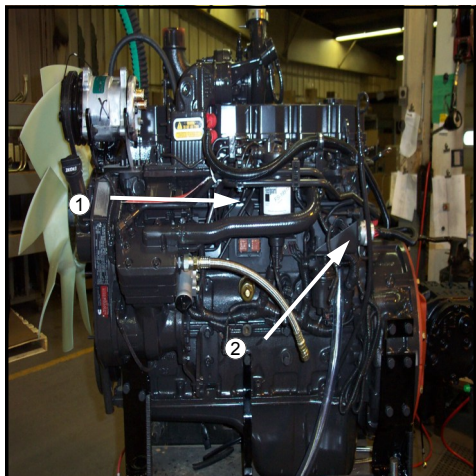

FIG 8.25

Fuel Filter

Filter (WATER SEPARATOR) - (fig. 8.25, item 1) Drain water and sediment from the separator daily. Replace every 500 hours or once a year, whichever comes first.

IN-LINE STRAINER - (fig. 8.25, item 2) Note direction of fuel flow arrow when replacing.

Fresh Air Cab Filters

PAPER FILTER - (fig. 8.26, item 1) The paper filter should be cleaned once a year, or more often if necessary. Remove the paper element and gently tap it against a flat surface. Direct low pressure compressed air through the filter to remove larger particles. Replace the paper filter if necessary.

CHARCOAL FILTER - (fig. 8.26, item 2) Remove and replace at the first sign of chemical odor entering the cab.

RECIRCULATING FILTER - (fig. 8.26, item 3) The recirculating filter may be cleaned with soap and water. Replace if it becomes worn.

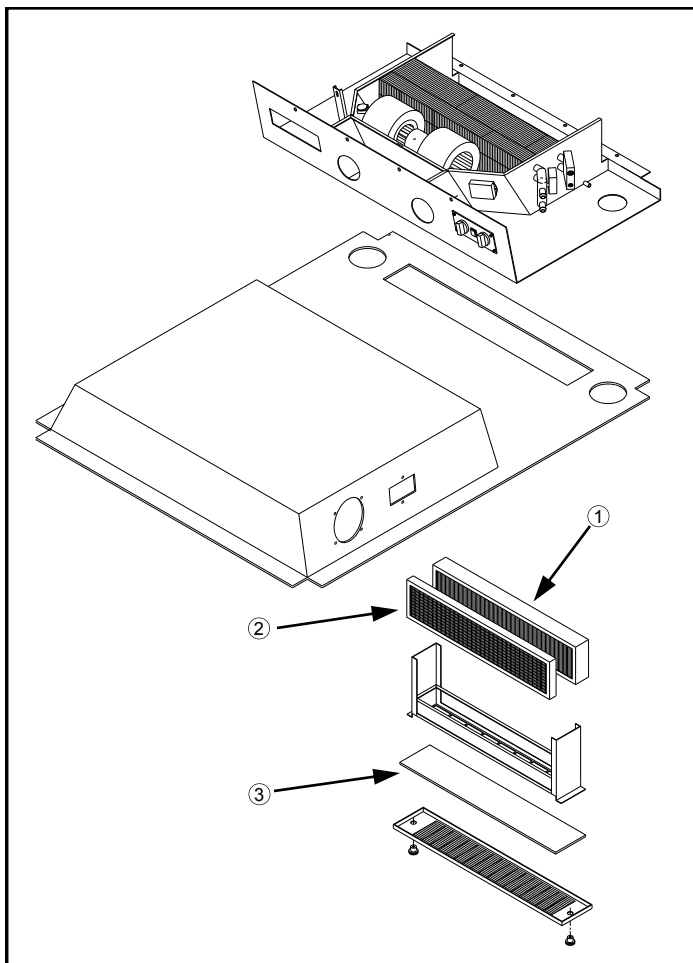

FIG 8.26



CAB FILTER LOCATION
FIG 8.27

VIII. SERVICE AND MAINTENANCE

LUBRICATION

Leg Bearings

The Hagie DTS 10 leg assemblies are constructed with upper and lower nylon bearings for suspension telescoping between the inner and outer leg weldments. These bearings must be lubricated to avoid bearing failure and ensure optimal ride quality. There are grease zerks located on the sides of the leg assemblies, one for the upper bearing (fig. 8.28, item 1) and two for the lower bearing (fig. 8.28, item 2). Greasing all bearings on all four legs daily is very important.

In late season crop applications, the grease may possibly be wiped off by passing crop leaves, so the bearing should be greased at least twice a day. Suggested times are in the morning and at noon. If the crop is mature enough, or plant population is high enough, more frequent leg bearing grease application may be required. This will ensure proper lubrication allowing optimal performance.

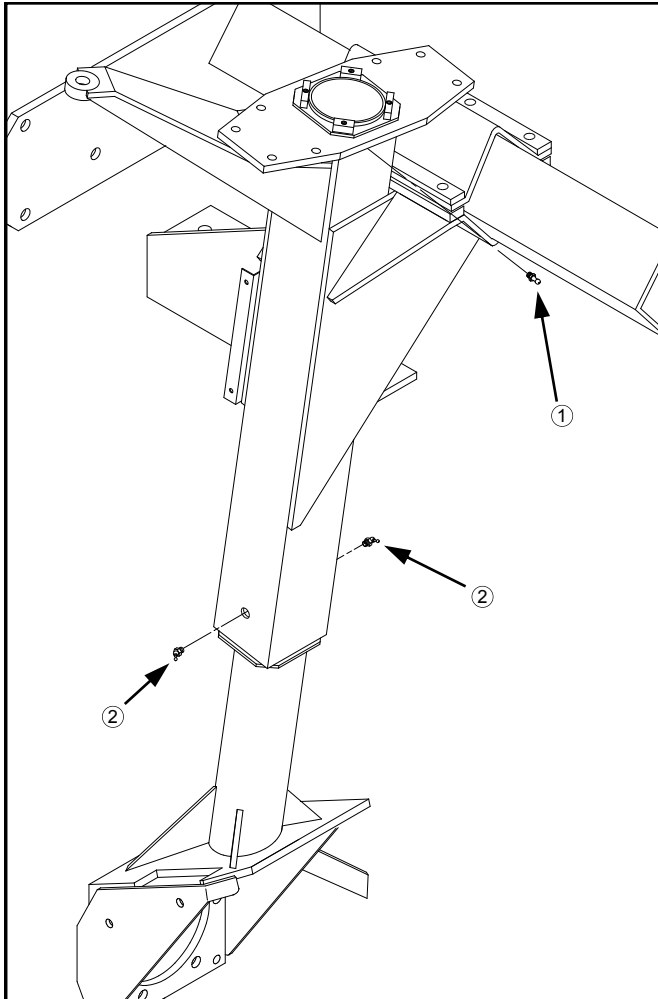

FIG 8.28A



FIG 8.28B

Jack Mount

Mounts to front or rear of any of the four legs, using two 1/2 x 2 1/2 inch bolts. Use a jack to lift the machine up to remove the tire and wheel (fig.8.28B).

VIII. SERVICE AND MAINTENANCE



FIG 8.29

Torque Hub[®] Seal Boot

Each leg has a seal boot located between the wheel motor and Torque Hub[®]. Grease the zerk on the wheel motor (fig. 8.29) every 50 hours.

An over-greased seal boot will leak some grease out around the seal and when heated may cause the appearance of a failed wheel motor leaking hydraulic fluid. Wipe off any excess grease after servicing.

Hydraulic Tread Adjust Bearing Slide-Path

The slide-path (fig. 8.30) for the hydraulic tread adjust nylon bearings should be generously coated with an appropriate lubricant. Standard grease applied by hand over the entire length of the bearing's range of travel should suffice.

Inspect this area often and lubricate as required. Failure to do so may cause one of the legs to hang up while the other is still sliding during adjustment. This will cause damage to the machine. Bear in mind that late season or taller crops may wipe off some or all of the exposed grease on the under-side of the mainframe.

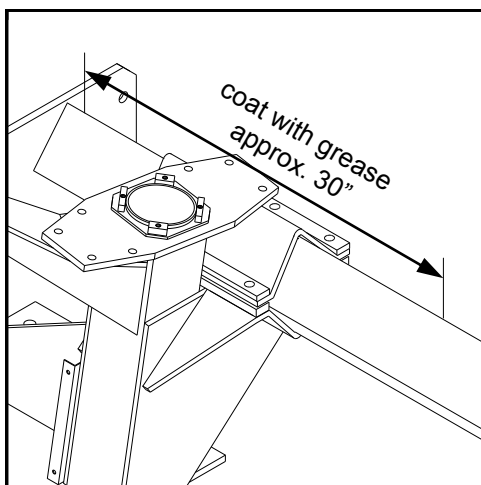

FIG 8.30

VIII. SERVICE AND MAINTENANCE

Transom/Lift Arm/Lift Cylinders

The transom, lift arm, and lift cylinders are fitted with grease zerks that should be lubricated every other day or 25 hours, whichever comes first. They are located as follows:

Lift arm lift pivots: eight places (fig. 8.31, items 1)

Lift cylinder pivots: four places (fig. 8.31, items 2)

Boom fold pivots on transom: four places (fig. 8.31, items 3)

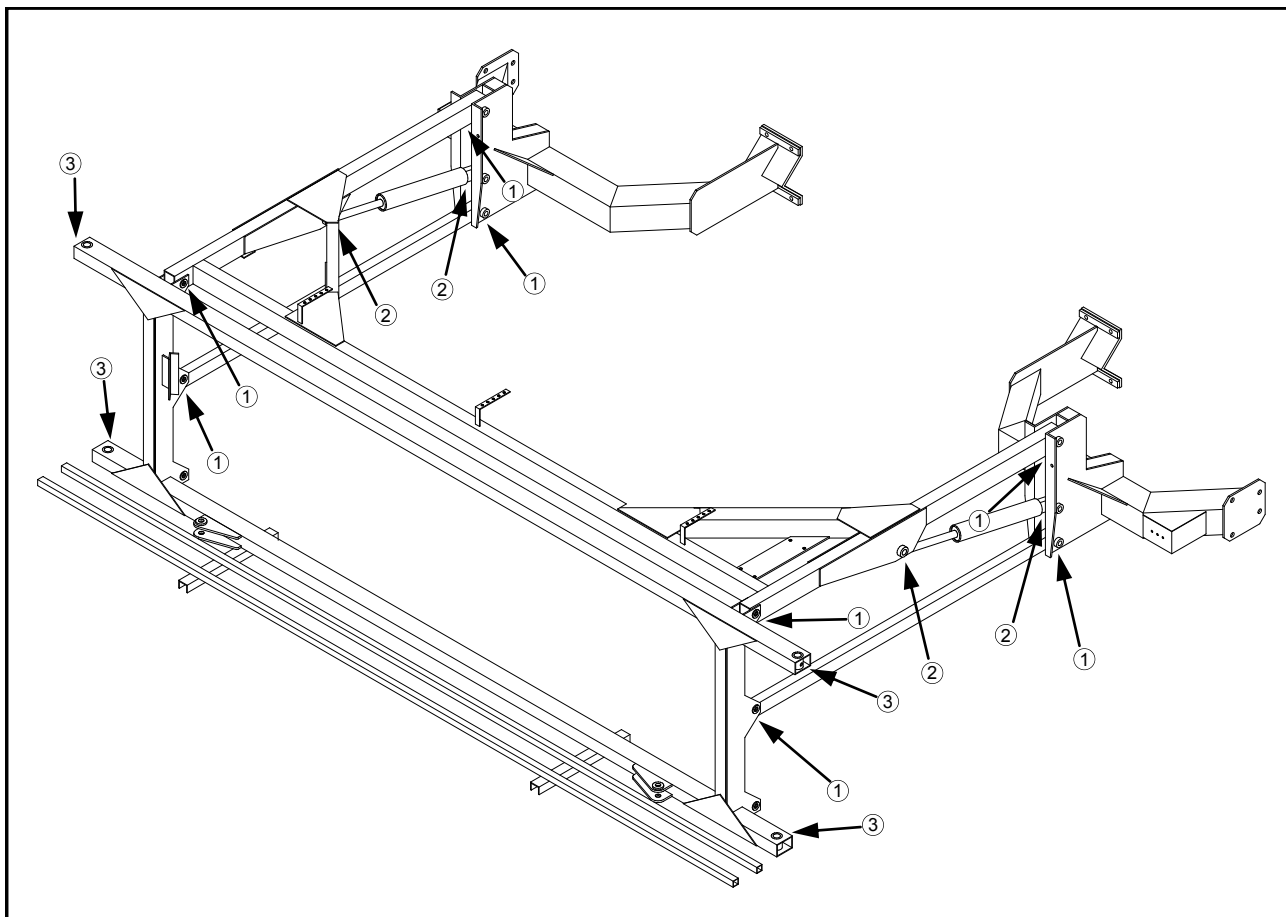

FIG 8.31

VIII. SERVICE AND MAINTENANCE

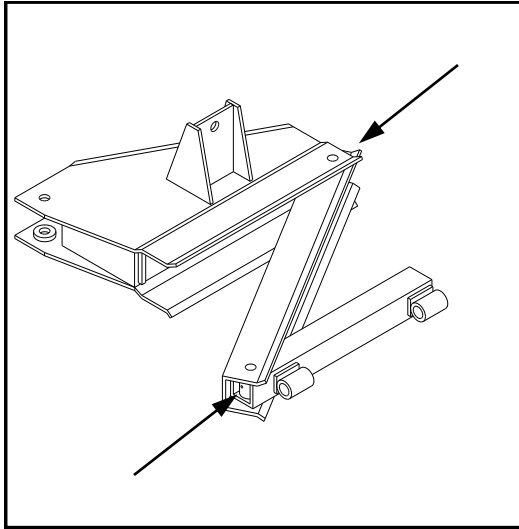

FIG 8.32

Boom Hinge and Breakaway Pivots

Each breakaway located between the transom and each inner boom section has two zerks (four total) that need to be greased as required (fig 8.32).

Sixty foot boom options have a grease zerk on the boom level pivot point connected to the breakaway (fig. 8.33, item 1), on the boom extension vertical folding pivot point (fig. 8.33, item 2), and on the boom folding link clevis pins (fig. 8.33, item 3). Eighty and ninety foot boom options also have these zerks in addition to zerks for the folding pivot of the outer boom breakaway (fig. 8.33, item 4). Check all and grease as required.

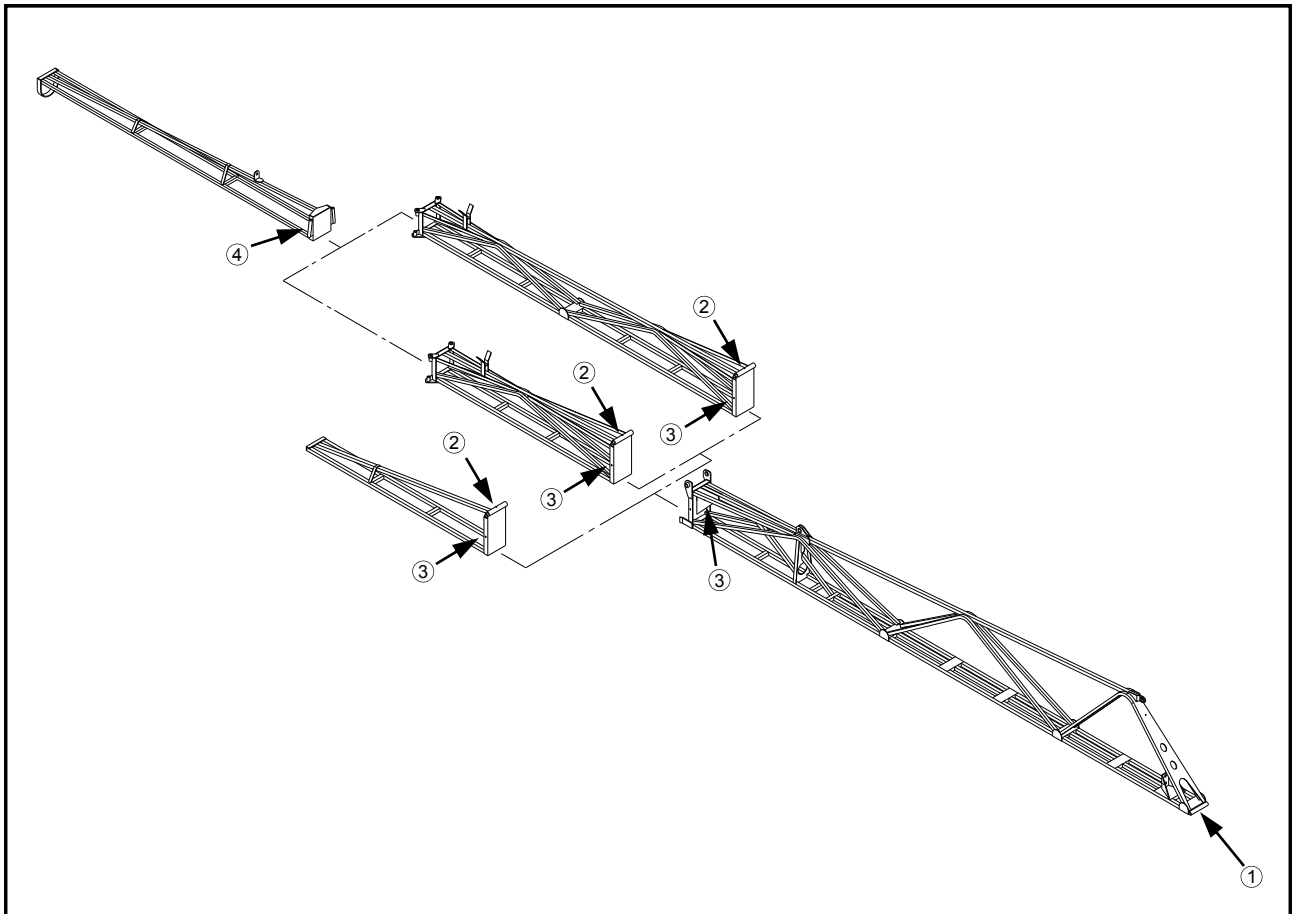

FIG 8.33

VIII. SERVICE AND MAINTENANCE

ELECTRICAL

Battery

SAFETY

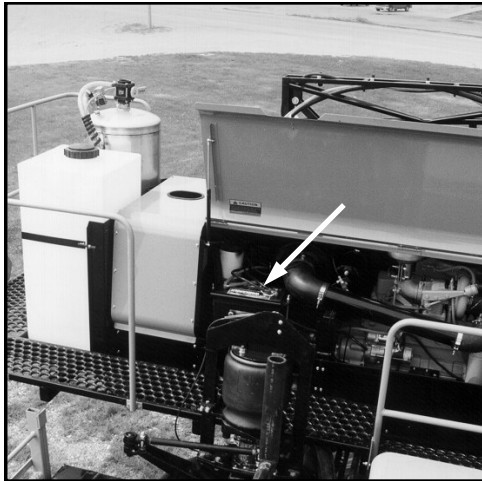

FIG 8.34

CAUTION

Batteries contain sulfuric acid. Avoid contact with skin, eyes, or clothing. Do not inhale fumes or ingest liquid. Batteries contain gases which can explode. Keep sparks and flame away while servicing.

SERVICE ACCESS - The battery is located at the rear of the machine under the right engine hood (fig. 8.34). It is mounted on a pivoting plate which, when unbolted and swung out, allows the operator ease of battery maintenance and filter access (fig. 8.35).



FIG 8.35

NOTE:

When servicing the electrical system always disconnect the battery. Remove the ground cable first and connect it last.

To unlock battery for access, remove the 3/8" bolt and nut that holds the battery in place. The battery is now able to pivot freely. When finished servicing area, return battery access plate back to original position and bolt it down. Take care not to pinch or cut any electrical cables or wires when returning battery to original position.

NOTE:

To ensure the best electrical contact, battery terminal connections should be as clean and as tight as possible.

VIII. SERVICE AND MAINTENANCE



FIG 8.36

CLEANING - Disconnect battery cables from battery. Remove all corrosion with a wire brush or battery post brush. Wash the cable connections and battery posts with a weak solution of baking soda or ammonia. Apply petroleum jelly or grease to prevent future corrosion. Reconnect the cables to the battery making sure they are tight. Clean every 100 hours.

CHARGING - To ease charging of the battery, there is a set of auxiliary battery charging posts on the rear of the sprayer's mainframe (fig. 8.36). Connect your charging cables to them just as you would to the battery, positive cable to positive terminal, and negative cable to negative terminal. Keep these terminals clean and their caps in place when not in use.

CAUTION

Electrical system is 12 volt negative ground. When using booster with jumper cables, precautions must be taken to prevent personal injury or damage to electrical parts.

1. Attach one end of jumper cable to positive terminal of booster battery and other end to positive terminal of vehicle battery connected to starter motor.
2. Attach one end of second cable to negative terminal of booster battery and other end to vehicle frame away from battery. Do not attach to cab or cab support.
3. To remove cables, reverse above sequence exactly to avoid sparks. See operator's manual for additional information.

STORAGE - See section 9 concerning proper battery storage.

REPLACEMENT - When replacing the battery, install a battery with ratings equivalent to or higher than the specs below.

VOLTAGE	12 V (<u>only</u>)
COLD CRANKING AMPS	950 CCA
(30 sec. at 0° F)	
RESERVE CAPACITY	185 min.
	at 25 amps

VIII. SERVICE AND MAINTENANCE



FIG 8.37

Fuses

Fuses protect individual lighter duty electrical circuits. The electrical panel is located on the rear wall of the cab to the right of the operator's seat. To gain access to the electrical panel, remove the three plastic panel screws (fig. 8.37).

If a fuse blows, remove it by pulling straight out. Do not pry it out with a screw driver. Replace each blown fuse with the same amperage fuse only. Correct fuse location and amperage is shown on page 100. If the fuse continues to blow, determine the cause and correct it.

Circuit Breakers

Mounted in Cab – Circuit breakers handle the functions of the heavier duty electrical circuits on the sprayer. They trip when overloaded and automatically reset themselves after they cool down. They will continue to trip and reset as long as the overload or short exists. If the circuit breaker does not reset, replace it with the same amperage breaker only. Correct circuit breaker location and amperage is shown on page 100. If a circuit breaker does not reset and continues to trip, determine the cause and correct it.

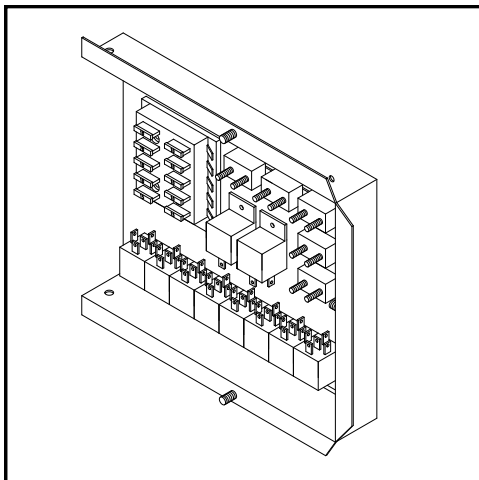

FIG 8.38

Mounted on Engine – The wire harnesses are protected by main circuit breaker mounted on the engine (fig. 8.39). If the breaker does not reset and continues to trip, determine the cause and correct it.

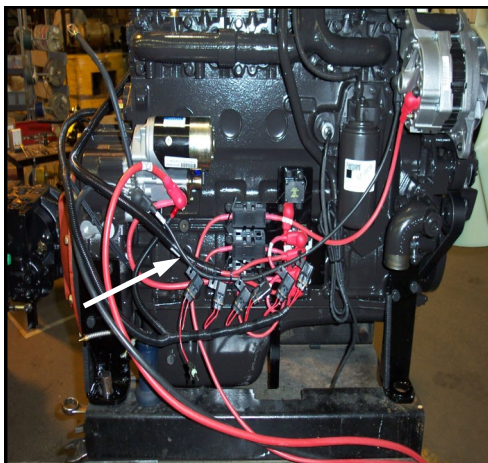

FIG 8.39

VIII. SERVICE AND MAINTENANCE

FUSES		CIRCUIT BREAKERS
Rinse system power and Gauges 10 AMP	AM/FM Radio 10 AMP	Starter relay 30 AMP
Seat power and Hydraulic tread adjust 20 AMP	CB radio and Dome light 10 AMP	Highway lights and Field lights 40 AMP
Spray solution valves 10 AMP	Tank solution valves and Rinse system control 10 AMP	Engine relay 100 Amp Located on engine
Flow ctrl, agitation, and Boom folding ctrlsa 10 AMP	Hazard/warning lights, Turn signal, and wiper 10 AMP	Work lights 30 AMP
Fuel tank selector and Parking brake 15 AMP	Boom lift control and Boom level control 15 AMP	Foam marker and Switch panel aux power .. 30 AMP
		A/C and Storage console aux pwr 30 AMP

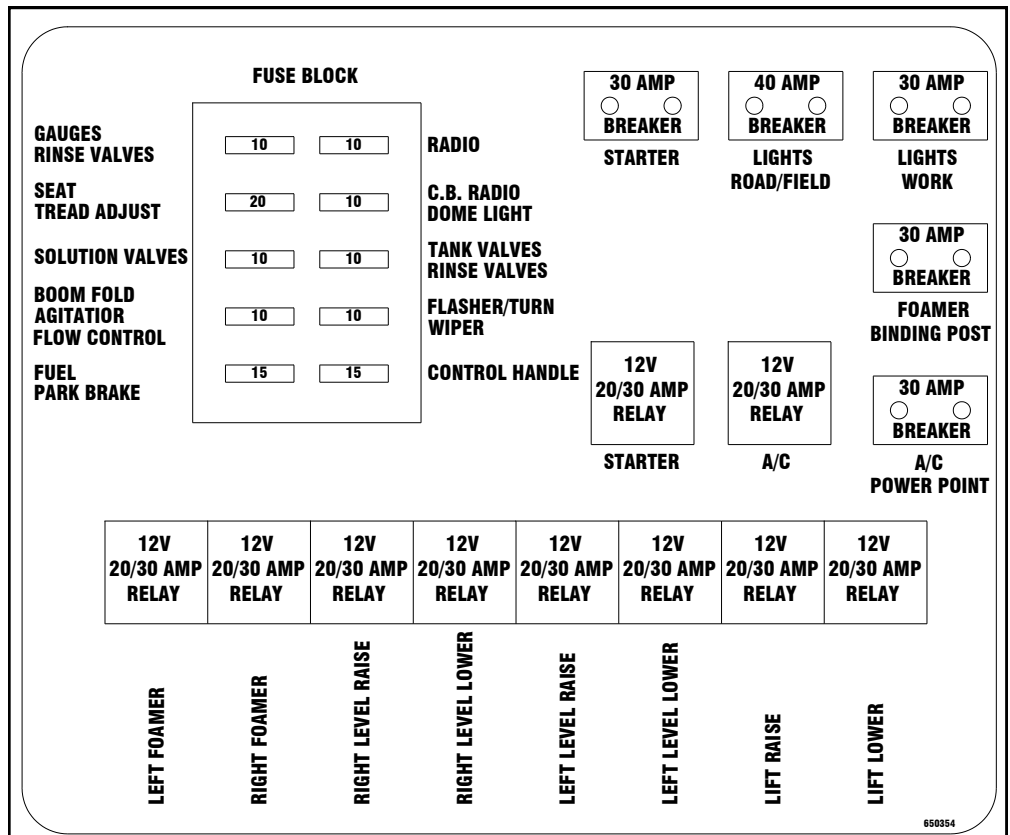

FIG 8.41

VIII. SERVICE AND MAINTENANCE

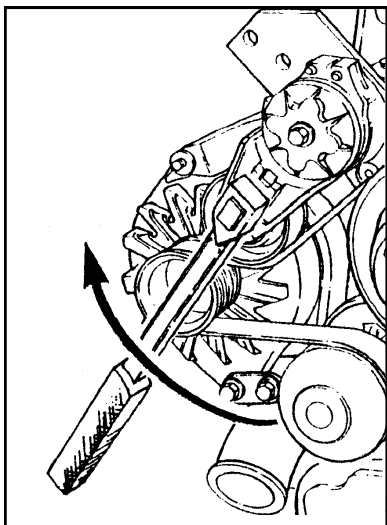

FIG 8.44

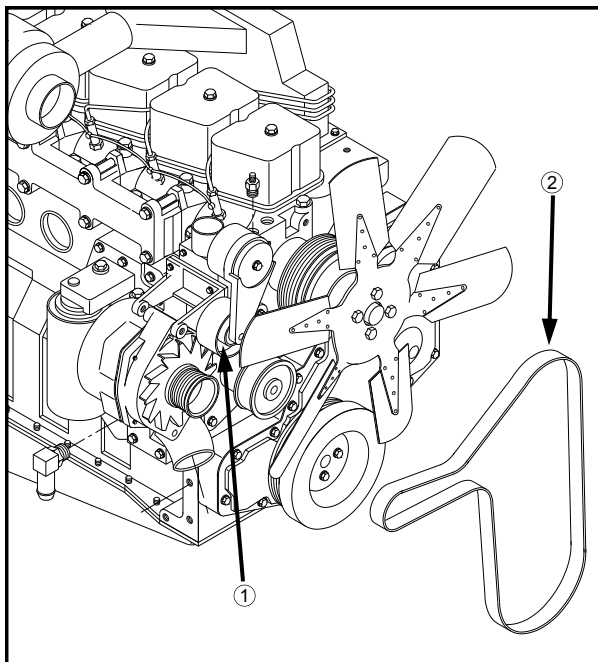

FIG 8.45

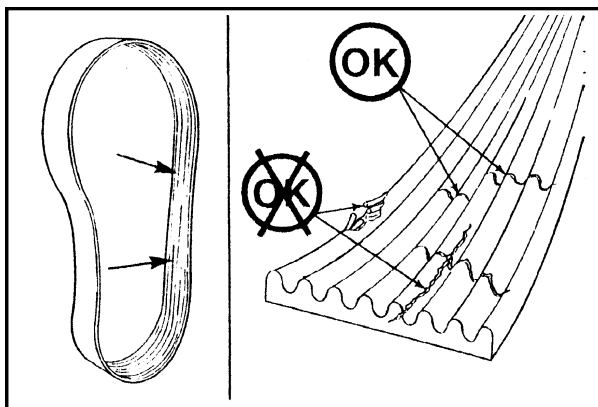

FIG 8.46

BELTS

Engine Drive Belt

REMOVAL - Insert a 3/8 inch square ratchet drive (fig. 8.44) into the belt tensioner (8.45, item 1) and lift upward to remove the belt (fig. 8.45, item 2).

INSPECTION - Visually inspect the belt daily. Check the belt for intersecting cracks (fig. 8.46). Transverse (across the belt width) cracks are acceptable. Longitudinal (direction of belt length) cracks that intersect with transverse cracks are not acceptable. Replace the belt if it is frayed or has pieces of material missing.

A/C Compressor Belt

To tighten air conditioner compressor belt, loosen the two pivot bolts (fig. 8.47, item 1) and the two slide bolts (fig. 8.47, item 2). Using a suitable prying tool, adjust tension on belt to desired tautness. While maintaining tension, re-tighten all four bolts. Inspect belt ever 250 hours.

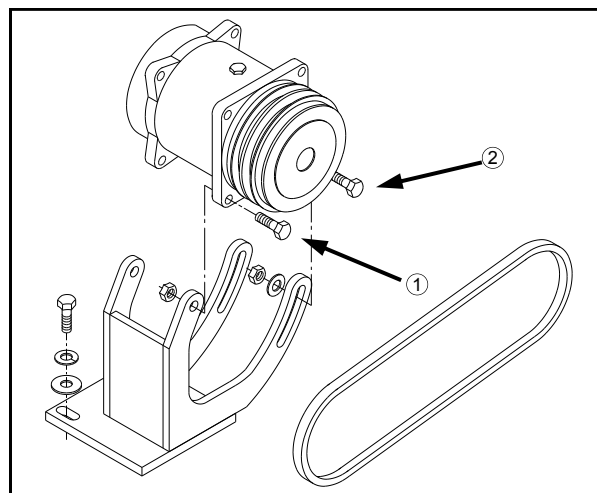

FIG 8.47

VIII. SERVICE AND MAINTENANCE

DRIVE TRAIN

Tandem Hydrostatic Pumps

NEUTRAL SETTING - When the hydrostatic lever is in the neutral position, the machine should not be moving in either direction. If it does, the neutral setting of the lever (fig. 8.48) on the hydrostatic pump needs to be adjusted. See accompanying pump manual.

REPAIR/REPLACEMENT - See pump handbook accompanying this operator's manual. Hydrostatic pumps are available as a core exchange item from Hagie Manufacturing Customer Support Department.

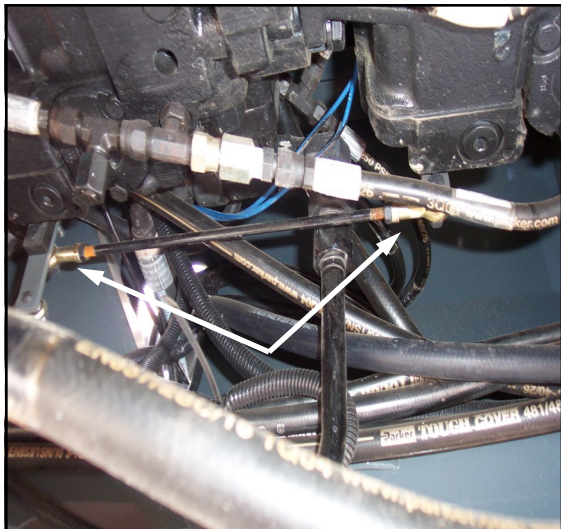

FIG 8.48

Auxiliary Gear Pumps

REPAIR/REPLACEMENT - See pump handbook accompanying this operator's manual. Gear pumps are available from the Hagie Manufacturing Customer Support Department.

Wheel Motors

REPAIR/REPLACEMENT - See wheel motor handbook accompanying this operator's manual. Wheel motors are available as a core exchange item from Hagie Manufacturing Customer Support Department.

Torque Hubs®

GREASE - Grease seal boot according to page 94.

OIL - Maintain oil level according to page 85.

REPLACEMENT - Torque Hubs® are available as a core exchange item from Hagie Manufacturing Customer Support Department.

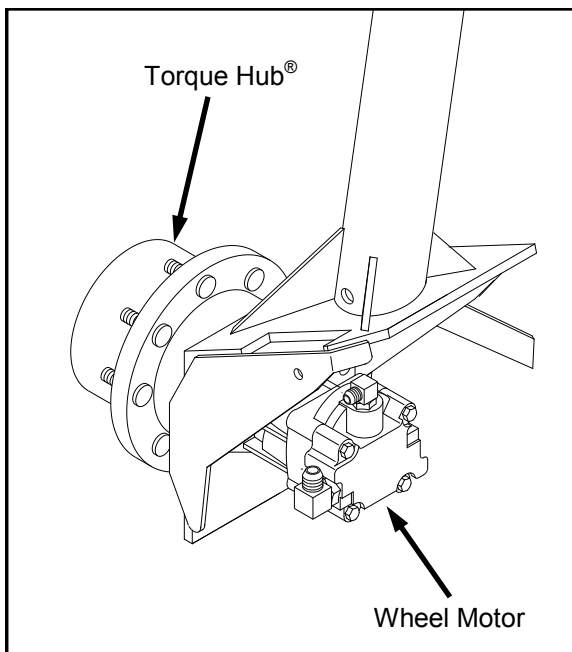

FIG 8.49

VIII. SERVICE AND MAINTENANCE



FIG 8.50

BOLT TORQUE

Wheel Bolts

Keep wheel bolts tight. See owner's manual for torque specifications.

To install wheel and tire assembly on the Torque Hub[®], lubricate studs with anti-seize grease. Align the wheel bolt holes with the Torque Hub[®] studs and mount the wheel on the hub.

NOTE:

To achieve even torquing consistency, the tire should be completely off the ground.

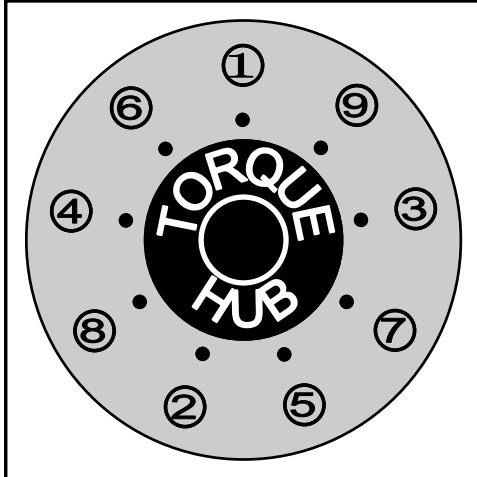

FIG 8.51

Start all of the lug nuts on and tighten them until they are just snug. Following the torque sequence in figure 8.51, first turn each lug nut to a torque value of 120 dry foot-pounds. Use slow, even pressure on the torque-wrench. Quick or jerky movements cause inaccurate values. Repeat the same sequence to 150 dry foot-pounds and again finally to 180 dry foot-pounds.

CAUTION

Check lug nut torque immediately after receiving machine and every 50 hours thereafter.

If the wheel turns during lug nut torquing, lower the machine to the ground just enough for the tire to touch and prevent rotation or more preferably, place a suitable wedge between the tire and the ground.

Lower the machine and resume operation. Recheck torque after 30 minutes of operation.

VIII. SERVICE AND MAINTENANCE

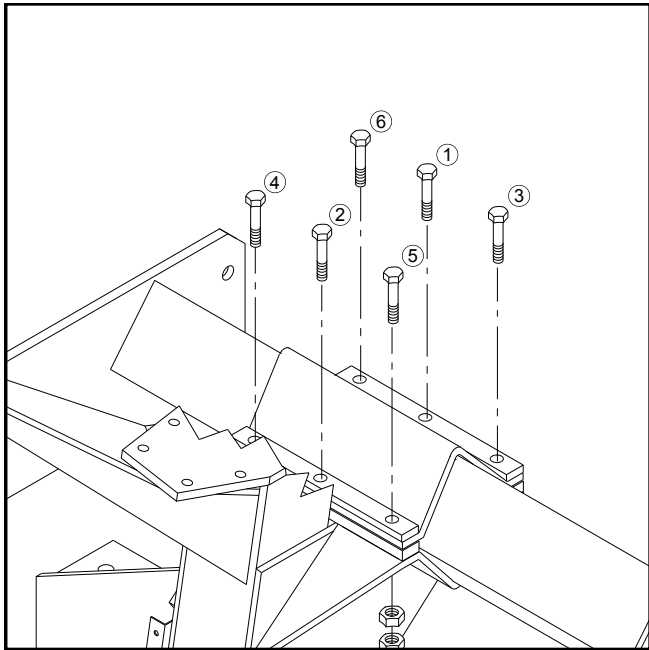

FIG 8.52A

Leg Mounting Bolts

See page 106 for additional information regarding leg mounting

After changing hydraulic tread adjust bearings or adding or removing mounting shims, follow these procedures for torquing the leg mounting bolts:



Never remove more than three leg mounting bolts from any single leg mount.

Start the nuts on the mounting bolts and tighten them until they are just snug. Following the torque sequence in figure 8.52A, turn each lug nut to a torque value of 100 foot-pounds. Use slow, even pressure on the torque wrench. Quick or jerky movements cause inaccurate values.

Lower the sprayer to the ground and repeat the same sequence to 130 foot-pounds and again finally to 160 foot-pounds.

Resume operation and recheck torque values after 30 minutes of operation.

VIII. SERVICE AND MAINTENANCE

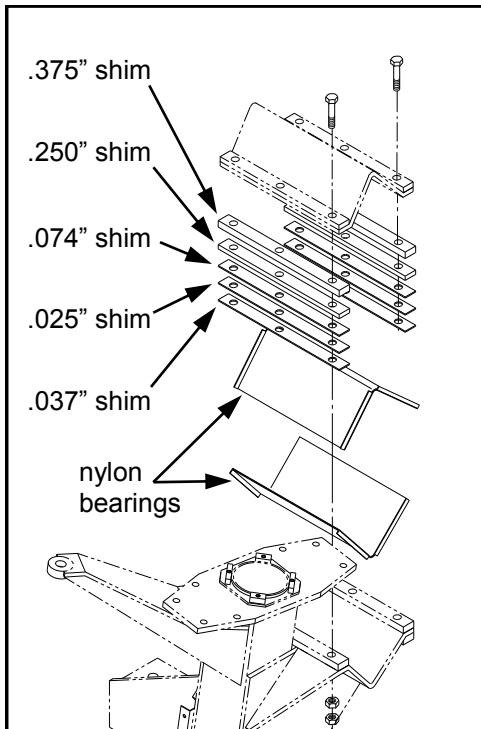

FIG 8.53

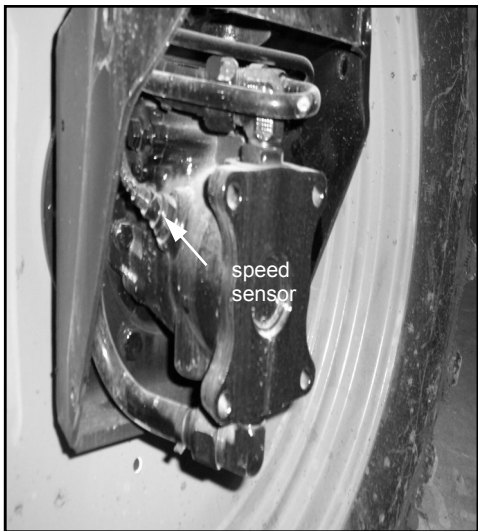

FIG 8.54

Tread Adjust Shim Adjustment

NOTE:

If the leg mount bolts have been tightened to the proper torque and the mount is loose, it may be that the bearing has worn and needs to be replaced. Check the bearing before you remove shims.

When adjusting for more or less bearing clearance, park the sprayer on level ground and shut off the engine. Block the wheel of the opposite side, both front and rear. Remove only three of the six leg mounting bolts at one time when removing or adding shims to the leg assembly. Refer to page 96 for leg mount bolt torque values and sequence.

WARNING

DO NOT loosen the leg mounting bolts to obtain more clearance for the leg to slide on the frame. Follow the above directions only for bearing clearance adjustment.

Speed Sensor Adjustment

(Left rear wheel motor - fig. 8.54) When installing or adjusting sensor, turn sensor in by hand until contact is made with speed ring. Back out one half turn (.030 gap). Rotate sensor until the wrench flats on housing are positioned at a 22 degree angle to motor shaft. Lock in place with lock nut. For further adjustment, see Sauer-Danfoss service manual.

VIII. SERVICE AND MAINTENANCE

TOE-IN

To correctly gauge toe-in, use a tape measure placed at one-half tire height on the front center seam of the front tire compared to the same measurement of the rear of the front tire (subtract the front measurement from the rear measurement - it must be a positive number). Correct toe-in should fall somewhere between one half and three quarters of an inch.

Toe-in is pre-set at the factory and should not have to be adjusted unless the steering cylinders

are removed.

Difficulty steering one way versus the other may also indicate incorrect toe-in and may require adjustment. For further assistance regarding toe-in measurement and adjustment, contact the Hagie Customer Support Department.

NOTE:

See page 108 for instructions on adjusting toe-in. See also page 38 for information on recalibrating self-centering cylinders.

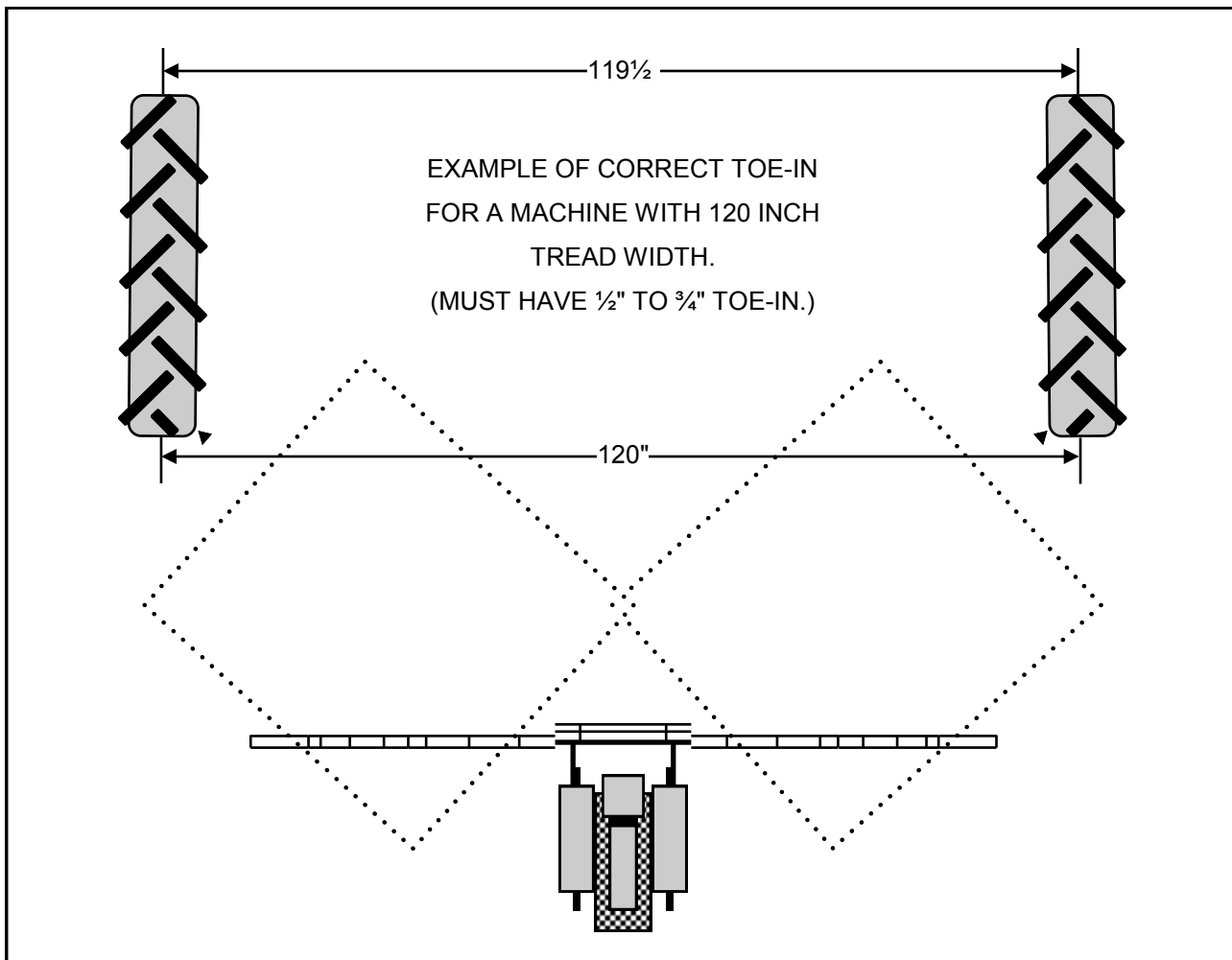

FIG 8.55

VIII. SERVICE AND MAINTENANCE

TOE-IN ADJUSTMENT

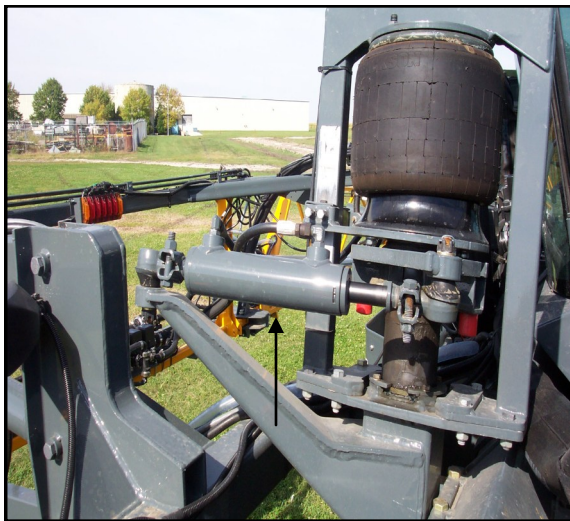

FIG 8.56

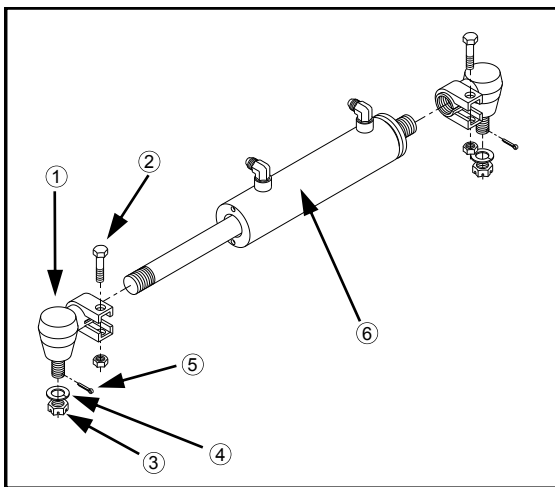

FIG 8.57

To adjust the toe-in of the front tires follow these instructions for both front steering cylinders carefully:

1. Remove cotter pin (fig. 8.57, item 5), castle nut (fig. 8.57, item 3), and lock washer (fig. 8.57, item 4).
2. Loosen lock collar bolt and nut (fig. 8.57, item 2).
3. Lightly tap swivel assembly (fig. 8.57, item 1) out of steering arm.
4. Move left and right tires evenly until difference in dimension "A" and "B" (fig. 8.58) are within specified range.

NOTE:

Dimension "A" should be $\frac{1}{2}$ " to $\frac{3}{4}$ " less than dimension "B." For more information regarding toe-in, see page 107

5. Screw swivel assembly in or out on steering cylinder (fig 8.57, item 6) until the treaded part lines up with steering arm.
6. Insert swivel assembly into steering arm.
7. Install lock washer and castle nut and tighten.
8. Install cotter pin.
9. Tighten lock collar bolt and nut.

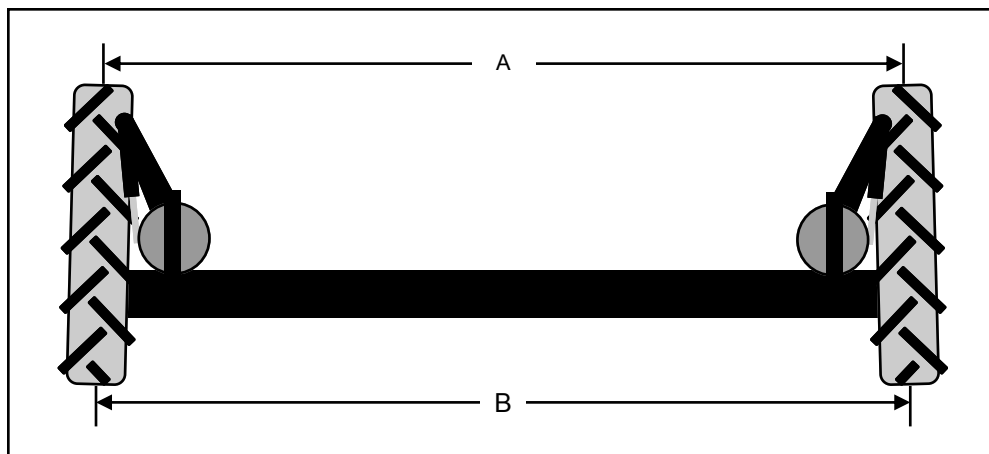

FIG 8.58

VIII. SERVICE AND MAINTENANCE



FIG 8.59

SPRAY SYSTEM

Solution Pump

PRIMING – In the event of loss of prime of the solution pump, remove the plug on the poly cross on top of the solution pump (fig. 8.59). Pour solution through the cross until the pump is full. Replace the plug and resume operation.

REBUILDING - Refer to accompanying handbook.

Line strainer

See page 91 for more information.

Spray Tips

At the beginning of each season, or as required, remove a random sample of nozzle caps (fig. 8.60, item 3) and inspect the nozzle tips. If they are plugged or worn, clean or replace them.

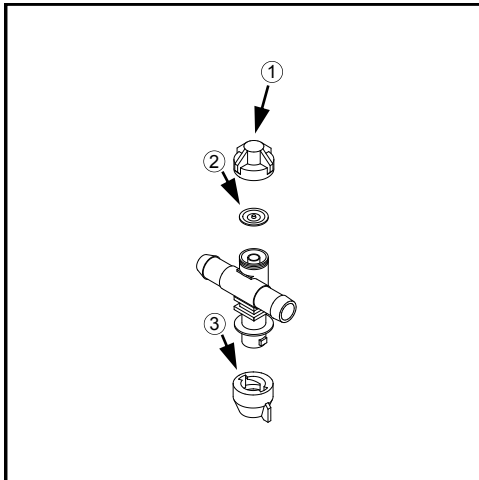

FIG 8.60

Nozzle Diaphragms

At the beginning of each spray season, remove each nozzle cap (fig. 8.60, item 1) and inspect the diaphragm for wear or fit (fig. 8.60, item 2). Replace if necessary. Refer to accompanying manual containing nozzle information.

Calibration

See pages 75-76, section six on spray system calibration.

Winter Storage

See page 113 on cold weather storage of spray system.

FOAM MARKER SYSTEM

Wet Tank

To prevent system condensation from contaminating the engine air compressor, remove moisture from the wet tank daily by pulling on its drain cord (fig. 8.61).



FIG 8.61

Winter Storage

See page 113 on storage of foamer system.

VIII. SERVICE AND MAINTENANCE



FIG 8.62



FIG 8.63

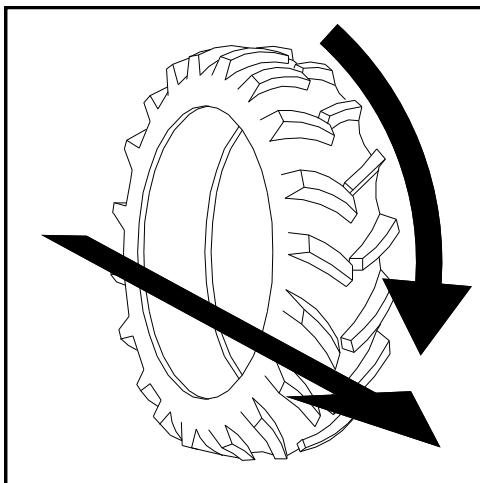

FIG 8.64

TIRES

Air Pressure

Check tire pressure once a week or every 50 hours of operation (fig. 8.62). Never inflate a tire more than the recommended maximum air pressure. Use an air line with a locking air chuck and stand behind tire tread while filling (fig. 8.63).

NOTE:

Tire pressure will depend on load quantity and type in solution tanks. Refer to page 24 for tire specifications.

WARNING

When inflating tire use extension hose with in-line air gauge and clip-on air chuck, which allow operator to stand clear of tire side wall explosion trajectory.

Wheel Bolts

See page 104 for recommended wheel bolt torque specifications and torquing pattern.

Mounting

If you do not have proper mounting equipment, let your local qualified tire sales/service dealer mount the tire for you. Tire should be mounted on rim according to figure 8.64 for best traction and tread cleaning action.

Toe-In

See pages 107-108 for information regarding toe-in measurement and adjustment.

VIII. SERVICE AND MAINTENANCE

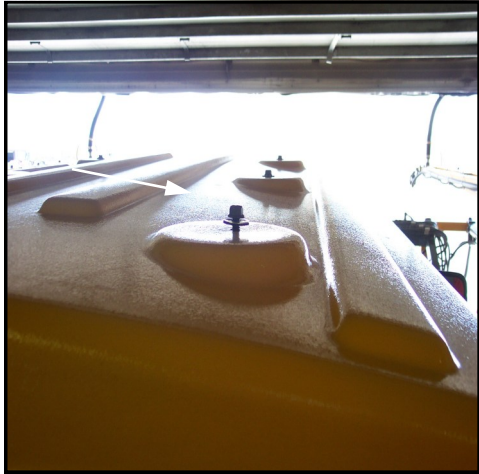

FIG 8.65

Roof Panel Access

To gain access under the roof panel, remove the six 3/8" bolts and rubber sealing washers (fig. 8.65). Lift and remove the roof panel (fig. 8.66), place the roof panel in a safe place so it won't drop to the ground or break. (fig. 8.67).

Service areas that can be accessed under the roof panel:

- A/C and heater blower
- A/C and heater hoses
- Radio memory fuse and in-line power fuse
- Speakers and speaker wiring
- Front roof-mounted field lights
- Rear roof-mounted work lights
- Headliner-mounted headlight/wiper/flasher control panel



FIG 8.66

When lowering the roof panel after servicing, take care not to pinch any wiring. When re-installing roof bolts, be sure sealing washers are in place to help maintain weather seal of cab roof.



FIG 8.67

VIII. SERVICE AND MAINTENANCE

DAILY INSPECTION

Inspection Point	Action (if necessary)
Check	
Engine oil level	Add oil
Radiator coolant level.....	Add antifreeze solution
Coolant overflow reservoir level	Add antifreeze solution
Engine drive belt	Replace belt
Filter Minder®	Replace air filter element
Hydraulic reservoir oil level	Add hydraulic oil
Neutral setting of hydrostatic pumps.....	Adjust setting
Solution line strainer.....	Remove and clean
Visual inspection of leg mounting bolts.....	Tighten
Battery	Clean and/or tighten
Radiator grille screens	Remove and clean
Look for loose or missing items such as shields.....	Tighten or replace
Look for any fluid leaks pooled on machine or ground	Determine cause and correct

Grease

Upper and lower leg bearings

See page 93

Drain

Wet tank.....

See page 109

Fuel/water separator

See page 92

IX. STORAGE

A. Preparing the sprayer for storage.

1. Perform daily level checks, lubrication, and bolt and linkage inspections as required in this manual in section eight on maintenance.
2. Every other season, drain the coolant from the engine and radiator. Probe the drain holes during draining to ensure they are not clogged by sludge, scale, or other deposits. Fill the cooling system to the top with a 50/50 water/antifreeze mixture. Run engine to operating temperature and re-check level.

NOTE:

If antifreeze is added, make sure the engine is then run to operating temperature to assure proper mixing of solution.

3. Add a fuel stabilizer to the fuel and fill fuel tank.
4. Run the engine until it is at operating temperature, then drain the engine oil. Refill with fresh oil of recommended weight and install a new lubricating oil filter element.
5. With the engine at normal operating temperature, cycle all hydraulic functions including the steering.
6. Release tension on all belts. For more detailed information, consult the manufacturer's handbook that accompanies this manual.
7. Use plastic bags and water-resistant adhesive tape to seal the air intake opening, all exhaust manifold openings, engine oil filler cap, hydraulic oil tank breather cap, and fuel tank caps.
8. Disconnect and remove battery or batteries. Completely clean and charge the battery. Coat the terminals with petroleum jelly and store battery in cool, dry place.
9. Thoroughly clean the sprayer. Touch up any painted surfaces that are scratched or chipped. For touch-up paint recommendations contact the Hagie Manufacturing Customer Support Department.
10. Replace worn or missing decals. See pages 11-16 for proper location of warning decals and their corresponding part number. Warning decals and all other Hagie decals are available through the Hagie Manufacturing Customer Support Department.

NOTE:

For replacement decals contact:
Hagie Manufacturing Company
Box 273, Clarion, IA 50525
Ph. 1-800-247-4885

IX. STORAGE

11. Use a multi-purpose grease to coat exposed hydraulic cylinder rods to prevent rusting which could result in cylinder damage.
12. To winterize the spray system, it is recommended that you use an environmentally-safe type antifreeze and water mixture that will give you adequate protection to minus 30 degrees below zero. Drain any remaining solution in the system and run the antifreeze mixture through the spray system until it comes out all boom openings. Repeat the above process with both the foam marker and rinse systems.
13. If the sprayer must be stored outside, cover it with a waterproof cover.

B. Removing the sprayer from storage.

1. Inspect the condition, and test the air pressure, of all tires. Please see page 114 for information regarding proper tire maintenance.
2. Carefully unseal all openings that were sealed in the storage process.
3. Clean and reinstall the battery. Be sure to attach the battery cables to the proper terminals.
4. Tighten all belts. Inspect and replace any worn belts. For information on belts, see page 104.
5. Check engine oil, hydraulic oil, and engine coolant levels; add, if necessary. A mixture of 50/50 antifreeze and water will cool adequately in summer as well as protect in winter.

NOTE:

Protective compounds such as grease can harden
Under exposure to weather conditions.

6. Completely clean the sprayer.
7. Review section eight on maintenance (pages 80-112), and perform all needed services as instructed.
8. For starting instructions, see pages 31-32 in section five on operating information.

NOTE:

See Warranty on page 123 concern-
ing **improper storage**.

X. TROUBLE SHOOTING

A. ENGINE

 **CAUTION**
Start engine from operator's seat only. When running engine in a building, be sure there is adequate ventilation.

PROBLEM	POSSIBLE CAUSE	SUGGESTED REMEDY
Engine won't crank	Dead battery Poor battery connections Neutral safety switch (located in the Sauer/Sundstrand pump) Starter or starter relay	Recharge or replace battery Clean and tighten Adjust and/or replace if needed Test; rebuild or replace
Engine won't start	Out of fuel Clogged fuel filter or strainer Cold weather Low starter speed	Fill fuel tank Replace fuel filter or strainer Refer to engine manual for cold weather starting information Check starter and battery

X. TROUBLE SHOOTING

PROBLEM	POSSIBLE CAUSE	SUGGESTED REMEDY
Engine overheats	<p>Engine overloaded</p> <p>Dirty radiator core or dirty grill screens</p> <p>Faulty radiator cap</p> <p>Loose or faulty fan belt</p> <p>Faulty thermostat</p> <p>Low coolant level</p>	<p>Reduce load</p> <p>Remove all foreign material and clean all items</p> <p>Replace cap</p> <p>Tighten or replace fan belt</p> <p>Replace thermostat</p> <p>Refill to proper level with recommended coolant</p>
Engine misfires: runs uneven, low power	<p>Water in fuel</p> <p>Dirty air cleaner element</p> <p>Poor grade of fuel</p> <p>Fuel tank vent clogged</p> <p>Clogged fuel filter</p>	<p>Drain, flush, replace filter, fill system</p> <p>Replace element</p> <p>Drain system; change to good grade</p> <p>Open fuel tank vent in cap</p> <p>Replace fuel filter</p>
Engine knocks	<p>Low oil level in crankcase</p> <p>Cold engine</p>	<p>Add oil to full mark</p> <p>Allow proper warm-up period; refer to engine owner's handbook</p>

NOTE:

For additional engine information, consult engine manufacturer's manual.

X. TROUBLE SHOOTING

B. SPRAY SYSTEM

WARNING

CHEMICALS ARE DANGEROUS

Read The Chemical manufacturer's labels to avoid injury or damage.

PROBLEM	POSSIBLE CAUSE	SUGGESTED REMEDY
Solution pump will not prime	Low water level in pump Air leak in suction line Solution valves turned off	Making sure the solution tanks are not empty, add solution through the plugged tee on top of solution pump; solution pump is normally self-priming once filled Inspect and tighten all fittings on suction line Turn solution valves to open position, allowing air to leave the system
Erratic reading on pressure gauge	Orifice in back of gauge clogged Faulty gauge Air leak in suction line Glycerin leaking from gauge	Remove gauge; clean orifice; re-install Replace gauge Inspect and tighten all fittings in suction line Replace gauge

X. TROUBLE SHOOTING

PROBLEM	POSSIBLE CAUSE	SUGGESTED REMEDY
Solution pump not producing normal pressure	Clogged line strainer screen	Remove screen; clean thoroughly; tighten strainer cap to avoid air leak
	Air leak in suction flow to pump	Inspect and tighten all fittings on suction line
	Restricted solution flow to pump	Main solution tank shut-off valve or valves not completely open
	Suction hose collapsed	Obstruction at inlet end of hose, causing high vacuum on hose
	Faulty hydraulic pump	Replace hydraulic pump
	Faulty hydraulic motor on solution pump	Replace motor
	Internal restriction of diaphragm such as build up of chemical	Disassemble; inspect; clean; reassemble
Malfunction of electric solution valve	Blown fuse	Replace fuse
	Faulty ground	Clean and tighten ground
	Dirty contact terminals	Clean contact terminals
	Separation in wire	Check continuity and replace wire
	Faulty switch	Replace switch
	Short in solenoid coil	Replace valve
	Bad valve	Replace valve

NOTE:

If your unit is equipped with a high-pressure system, call the Hagie Manufacturing Customer Support Department for possible causes and suggested remedies.

X. TROUBLE SHOOTING

C. HYDROSTATIC SYSTEM



CAUTION

DO NOT GO NEAR LEAKS. High pressure oil easily punctures skin causing injury, gangrene, or death. If injured, seek emergency medical help. Immediate surgery is required to remove oil. Do not use finger or skin to check for leaks. Lower load or relieve hydraulic pressure before loosening fittings.

PROBLEM	POSSIBLE CAUSE	SUGGESTED REMEDY
Machine won't move in either direction	Engine speed too low Oil level in reservoir low Control linkage Clogged filter Hydrostatic pump not turning Faulty hydrostatic pump Air leak in suction line Low charge pressure	Set engine at operating RPM before trying to move machine Fill reservoir to proper level w/ approved oil; see section on Service and Maintenance Repair or replace Replace filter Check drive coupling Replace pump Inspect and tighten all fittings on suction line See section under charge pressure
Machine will move in only one direction	Faulty high pressure relief valve	Switch relief valves from side to side; If problem reverses, replace multi-function valve (Call Hagie Customer Support and refer to parts manual)

X. TROUBLE SHOOTING

PROBLEM	POSSIBLE CAUSE	SUGGESTED REMEDY
Hydrostatic system responding slowly	<p>Engine speed too low</p> <p>Oil level in reservoir low</p> <p>Cold oil</p> <p>Plugged filter</p> <p>Partially restricted suction line</p> <p>Internal damage</p>	<p>Set engine at operating RPM before trying to move machine</p> <p>Fill reservoir to proper level with approved oil; see section on Service and Maintenance</p> <p>Allow for adequate warm-up period</p> <p>Check and replace filter</p> <p>Inspect for collapsed suction hose</p> <p>Replace hydrostatic pump or motor</p>
Noisy hydrostatic system	<p>Cold oil</p> <p>Low engine speed</p> <p>Oil level in reservoir low</p> <p>Air in system</p> <p>Internal damage to pump</p>	<p>Allow for adequate warm-up period</p> <p>Increase engine speed</p> <p>Fill reservoir to proper level with approved oil; see section on Service and Maintenance</p> <p>Inspect and tighten all fittings on suction line</p> <p>Replace pump</p>
External oil leaks	<p>Loose or faulty fittings</p> <p>Damaged O-ring</p> <p>Faulty hose</p>	<p>Tighten or replace</p> <p>Inspect; if damaged replace</p> <p>Replace hose</p>

X. TROUBLE SHOOTING

D. HYDRAULIC SYSTEM



CAUTION

DO NOT GO NEAR LEAKS. High pressure oil easily punctures skin causing injury, gangrene, or death. If injured, seek emergency medical help. Immediate surgery is required to remove oil. Do not use finger or skin to check for leaks. Lower load or relieve hydraulic pressure before loosening fittings.

PROBLEM	POSSIBLE CAUSE	SUGGESTED REMEDY
Entire hydraulic system fails to function	<p>Oil level in reservoir low</p> <p>Oil not reaching pump</p> <p>Faulty hydraulic pump</p>	<p>Fill reservoir to proper level with approved oil; see section on Service and Maintenance</p> <p>Prime the pump by removing suction hose from reservoir; hold removed end higher than pump; hand feed two (2) quarts approved oil through suction hose by bumping engine w/ starter (careful not to start engine); re-install hose; tighten all fittings</p> <p>Replace hydraulic pump</p>
Noisy hydraulic pump	<p>Collapsed suction hose caused by cold oil</p> <p>Oil level in reservoir low</p> <p>Air leak in suction line</p>	<p>Allow for adequate warm-up period</p> <p>Fill reservoir to proper level with approved oil; see section on Service and Maintenance</p> <p>Inspect and tighten all fittings on suction hose</p>

X. TROUBLE SHOOTING

E. ELECTRICAL

CAUTION

Batteries contain sulfuric acid. Avoid contact with skin, eyes, or clothing. Do not inhale fumes or ingest liquid. Batteries contain gases which can explode. Keep sparks and flame away while servicing.

NOTE:

Disconnect battery when servicing any part of electrical system to prevent system damage.

PROBLEM	POSSIBLE CAUSE	SUGGESTED REMEDY
Entire electrical system is dead	Dead battery Poor battery connection Low charging rate No charging rate	Charge or replace Clean and tighten Tighten alternator belt Replace alternator
All gauges on instrument panel not working	Blown fuse Poor ground	Replace fuse Clean and tighten ground
Tachometer/MPH Indicator not working	Blown fuse Loose connections at sensor/alternator Faulty sensor	Replace fuse Tighten or replace connectors Replace sensor
Light system does not function	Blown fuse Poor ground Burned-out bulb Separation or short in wire Faulty switch	Replace fuse Clean and tighten ground Replace bulb Check continuity and replace wire Replace switch

XI. LIMITED WARRANTY

2013 PRODUCT WARRANTY

Hagie Manufacturing Company Product Warranty

Hagie Manufacturing Company warrants each new Hagie product to be free under normal use and service from defects in workmanship and materials for a period of lesser of: two (2) years or 1000 hours from the date of delivery on all Agricultural Products. Hagie Manufacturing Company makes this warranty from the original delivery date and is transferable to a purchaser from the original purchaser of this equipment, given there is remaining time left under the year and hour warranty standard stated above. This warranty shall be fulfilled by repairing or replacing free of charge any part that shows evidence of defect or improper workmanship, provided the part is returned to Hagie Manufacturing Company within thirty (30) days of the date that such defect or improper workmanship is discovered, or should have been discovered. Labor to repair said items will be covered by standard labor time rates. Freight charges of defective parts are not covered by this warranty and are the responsibility of the purchaser. No other express warranty is given and no affirmation of Hagie Manufacturing Company, by words or action, shall constitute a warranty.

Hagie Manufacturing Company limits its warranty to only those products manufactured by Hagie Manufacturing Company and does not warrant any part or component not manufactured by Hagie Manufacturing Company, such as parts or components being subject to their manufacturer's warranties, if any. Excluded from this warranty are parts subjected to accident, alteration, or negligent use or repair. This warranty does not cover normal maintenance such as engine tune ups, adjustments, inspections, nor any consumables such as tires, rubber products, solution system valves, wear parts, wiper blades, etc.

Hagie Manufacturing Company shall not be responsible for repairs or replacements which are necessitated, in whole or in part; by the use of parts not manufactured by or obtainable from Hagie Manufacturing Company nor for service performed by someone other than Hagie authorized personnel, unless authorized by Hagie Manufacturing Company. Customer acknowledges that it is not relying on Hagie Manufacturing Company's skill or judgment to select finish goods for any purpose and that there are no warranties which are not contained in this agreement.

In no event shall Hagie Manufacturing Company's tort, contract, or warranty liability exceed the purchase price of the product. The foregoing limitation will not apply to claims for personal injury caused solely by Hagie Manufacturing Company's negligence.

Hagie Manufacturing Company shall not be liable for damages, including special, incidental or consequential damages or injuries (damage and repairs of equipment itself, loss of profits, rental or substitute equipment, loss of good will, etc.) arising out of or in connection with performance of the equipment or its use by customer, and Hagie Manufacturing Company shall not be liable for any special, incidental or consequential damages arising out of or in connection with Hagie Manufacturing Company's failure to perform its obligation hereunder. HAGIE MANUFACTURING COMPANY'S ENTIRE LIABILITY AND THE CUSTOMER'S EXCLUSIVE REMEDY SHALL BE REPAIR OR REPLACEMENT OF PARTS COVERED UNDER THIS WARRANTY. THIS WARRANTY IN LIEU OF ALL OTHER WARRANTIES, EXPRESSED OR IMPLIED, INCLUDING, BUT NOT LIMITED TO THE IMPLIED WARRANTY OF MERCHANTABILITY OR FITNESS FOR A PARTICULAR PURPOSE.

INDEX

	PAGE		PAGE
A		E	
Air Conditioning System		Electrical System	
Belt	102	Battery	97-98
Cab Filters		Circuit Breakers.....	99
Fresh Air Intake	92	Fuses	99
Charcoal	92	Relays	101
Recirculation	92	Engine	
Charging System	88	Cantrak.....	33-34
Climate Controls	69	Cold Weather Starting.....	32
Dryer	91	Fuel	87
Agitation System		Filters	92
Adjusting Hydraulic Flow Speed	55	Oil.....	84
Operation	55	Operation	31-32
Antifreeze	86	F	
Attaching		Fence Row	
Boom Options	29	L.E.D. Indicator	52
Lift Arm Assembly.....	27	Operation	52
Transom Assembly	28	Filter Minder®	89
Auxiliary Power Supplies	74	Filters	
B		Air Conditioning Dryer	91
Battery	97-98	Cab	
Belts	102	Charcoal Filter.....	92
Binding Post Power Supply	74	Fresh Air Intake Filter.....	92
Bolt Torque Values		Recirculation Filter	92
Leg Mounting Bolts	105	Engine Air Intake Filter.....	89
Wheel Lug Nuts	104	Fuel Filters	92
Boom		Hydraulic Charge Pressure Filter	90
Cradling.....	46	Hydraulic High-Pressure In-Line Filters	
Lubrication	93-94	Boom Control Stackvalve.....	91
Operation		Tread Adjust Stackvalve	91
Fold		Hydraulic Suction Filter	90
Horizontal.....	44	Solution Line Strainer.....	91
Vertical Extension	45	Radiator Grille Screens	90
Level	43	Fresh Air Intake Filter, Cab	92
Lift.....	42	Fluid Capacities	88
C		Fluids	
Cab	64-74	Air Conditioning Charge	88
Auxiliary Power Supplies	74	Cooling System Coolant.....	86
Climate Controls	69	Engine Oil.....	84
Emergency Exit.....	68	Fuel	87
Filters		Hydraulic Oil.....	84
Charcoal Filter	92	Torque Hub® Oil	85
Fresh Air Intake Filter	92	Windshield Washer	88
Recirculation Filter	92	Foam Marking System	
Seat Operation.....	71	Adjusting System Pressure	58
Calibration	75-76	Draining Wet Tank	109
Charcoal Filter, Cab	92	Filling.....	59
Charge Pressure Filter	90	Operation	58
Cigarette Lighter-Type Power Supply	74	System Pressure Gauge	58
Circuit Breakers	99	Wet Tank.....	109
Climate Controls, Cab	69	Fuel Filters	92
Cold Weather Starting	32	Fuel Tank Selector Switch	70
Cooling System		Fuses	99
Coolant.....	86		
Radiator Grille Screens.....	90		

INDEX

	PAGE		PAGE
H		Q	
High Pressure In-Line Filters	91	Quick Fill, Rear	54
Hydraulic Tread Adjust		R	
Bearings	94	Radiator Grille Screens	90
Shim Adjustment	106	Rear Fill	54
Operation	38-39	Recirculation Filter, Cab	92
Tread Width Indicators	39	Relays	101
Hydrostatic Drive System		Rinse System	60-62
Operation	35	Roof Panel Access	111
Neutral Setting	103	S	
J		Safety	4-10
Jack Mount	93	Seat	71
L		Seal Boot, Torque Hub®	94
L.E.D. Indicators		Serial Number Locations	17-18
Boom Solution Valve	51	Service/Maintenance	80-112
Fence Row Nozzle	52	Solution Line Strainer	91
Lift Arm Assembly		Solution Pump	50
Lubricating	95	Solution Tank Shutoff Valves	53
Mounting	27	Specifications	19-24
Lights		Spray Booms	
Field Lights	64	Cradling	46
Hazard/Warning Lights	66	Operation	
Highway Lights	64	Fold	
Interior Lights	65	Horizontal	44
Running Lights	66	Vertical Extension	45
Turn Signals	66	Level	43
Work Lights	65	Lift	42
Lubrication		Sprayer Dimensions	19
Boom Hinge	96	Spray System	
Breakaway	96	Boom Solution Valves	51
Leg Bearings	93	L.E.D. Indicators	
Torque Hub® Seal Boot	94	Boom Solution Valves	51
Transom, Lift Arm, & Lift Cylinder Assembly	95	Fence Row Nozzle	52
Tread Adjust Bearing Slide Path	94	Maintenance	
Limited Warranty	123	Nozzle Inspection	
Lug Nuts	104	Diaphragm	109
M		Spray Tip	109
Maintenance Schedule	80	Priming Solution Pump	109
O		Operating Instruction	49
Operating Information	31-74	Solution Pump	
P		Pressure	44
Parking Brake	36	Priming	109
Preparing to Operate	25-30	Solution Switches	
Pressure Washing System	63	Boom Solution Switches	51
Pressure Gauges		Main Solution Switch	51
Foamer System Air Pressure	58	Solution Tank Shutoff Valves	53
Pressure Washing System Pressure	63		
Solution Spray System Pressure	50		

INDEX

	PAGE		PAGE
Steering Column Tilt	73	Transporting Sprayer	77-79
Suction Filter	90	Tread Width	
T			
Table of Contents	3	Adjusting	
Tires		Hydraulically	38-39
Air Pressure	110	Manually	25-26
Filling	110	Indicators	39
Mounting	110	Trouble Shooting Guide	115-122
Specifications	24	W	
Toe-In		Warning Decal Location	11-16
Adjusting	108	Warning Symbol Definitions	2
Checking	107	Warranty	123
Torque Hubs®		Wheel Lug Nuts	104
Oil Level	85	Windshield Washer/Wiper	
Seal Boot Lubrication	94	Operation	70
Torque Values		Reservoir	88
Leg Mount Bolts	105	Winter Storage Directions	113-114
Wheel Lug Nuts	104		
Transom Assembly			
Lubricating	95		
Mounting	27		

NOTES
