

PARTS MANUAL
FOR
HAGIE MODEL DTS 10 HI-TRACTOR

HAGIE MANUFACTURING COMPANY

BOX 273 CLARION, IOWA 50525

COVERS MACHINE SERIAL NUMBERS: U1410550001 thru U1410550100

03-05 493330

11-08, 02-15, 02-16, 03-17

To obtain the most current parts manual for your machine, please visit www.hagiehelp.com.
© 2005, 2008, 2015-17 Hagie Manufacturing Company. Clarion, Iowa USA

SPRAYER IDENTIFICATION

Each Hagie sprayer is identified by means of a frame serial number. This serial number denotes the model, the year in which it was built, and the number of the sprayer. As for further identification, the engine has a serial number and the planetary hubs have identification plates that describe the type of mount and gear ratio. To insure prompt, efficient service when ordering parts or requesting service repairs from Hagie Manufacturing Company, record the serial and identification numbers in the space provided below.

NOTE: Reference to left hand and right hand used throughout this manual refers to the position when seated in the operator's seat facing forward.

This manual is not intended to be a complete guide for machine maintenance and repairs. If you are not properly trained to perform service on this machine, contact Hagie Customer Support for assistance. Improper maintenance or repair may result in property damage, personal injury, or death.

SPRAYER SERIAL NUMBER

ENGINE SERIAL NUMBER

PLANETARY HUB IDENTIFICATION NUMBERS

TABLE OF CONTENTS

ENGINE ASSEMBLY4-7
AIR TANK ASSEMBLY8-9
LOOP FLUSHING10-11
WHEEL MOTOR VALVES.12
VFC AND FLOW DIVIDER.13-18
RADIATOR AND OIL COOLER ASSEMBLY.19
OIL TANK ASSEMBLY20
TIRE ASSEMBLY21
LEG ASSEMBLY.22-29
STEERING CYLINDER30-31
MUFFLER AND AIR CLEANER32-33
CAB ASSEMBLY.34-38
INSTRUMENT PANEL ASSEMBLY39
CONSOLE ASSEMBLY.40-42
SWITCH PANEL ASSEMBLY43
FUSE BOX AND SEAT44-45
SHEET METAL46-47
FOAM AIR REGULATOR AND RECOVERY TANK.48-49
LADDER.50-51
FUEL TANK52
SERVICE PLATFORM.53
FRESH WATER TANK54
BOOM CRADLE55
BATTERY56
SOLUTION TANK57-61
SOLUTION SOLENOIDS.62-69
QUICK FILL AND FENCE ROW.70-72
REAR NOZZLE73
SOLUTION HOISING74-77
SOLUTION PUMP79
TRANSON, BOOM, AND LIFT COMPONENTS.80-93
RINSE94-95
FOAMER.96-97
TREAD ADJUSTMENT OPTION98-100
PRESSURE WASHER101-102
RADAR OPTION.103
INJECTION PLATFORM AND FOAMER DIVERT VALVE OPTION104-105
FLOW MAX 110 MONITOR OPTION.106
WINDSHIELD WASHER.107
DECALS.108-109
HYDRAULIC SCHEMATIC110-115
ELECTRICAL SCHEMATIC.116-125
ABBREVIATIONS126
INDEX127
PARTS ORDER FORM.131

ENGINE ASSEMBLY

DET. QTY PART NO. DESCRIPTION

1	2	311053	RUBBER MOUNT SET,SSB26-1000-1
2	1	314995	LWR RADIATOR HOSE 2101 03
3	2	193012	QUICKEDGE TRIM .135 TO .250
4	1	291003	FUSE, 150 AMP 32V DC
5	1	291531	BATT CABLE,BLK 15"4GA.406-.406
6	2	291813	FUSE, 125 AMP 32V DC
7	1	311075	RAD HOSE,1.75 X 23(52823 GDYR)
8	1	314836	TEMP SENDR 280D 1/2NPT FOR GA
9	1	316559	OIL FILTER, CUMMINS
10	1	316250	RH FRT ENG MT WLD, CUMM 94
11	1	316313	LH FRT ENG MT WLD, 284 CUMM 98
12	1	316551	FAN, 24" CUMM QSB205, 2101 03
13	1	316336	RH HYD TUBE MT, 2100 98
14	3	291814	FUSE HOLDER, HIGH AMP
15	1	291815	CIRCUIT BREAKER,100 AMP BUSS
16	2	291833	CONTACTOR RELAY,15VDC 100A
17	1	316557	ENGINE BREAKER MT PLT, 2101 03
18	1	470274	TUBE CLAMP BODY,.750-.750
19	1	470276	CLAMP COVER PLATE,SNGL, 2.55LG
20	1	470278	CLAMP WELD PLATE, SNGL, 2.75LG
21	10	470122	1/4UNC X 1/2 FLANGE HEX BOLT
22	5	473775	12MM-1.75 X 30MM HEX BOLT
23	4	473798	10MM LOCK WASHER
24	3	473783	12MM-1.75 X 25MM HEX BOLT
25	8	473784	12MM LOCK WASHER
26	1	601597	HOSE, 3/8 X 26 HEATER
27	1	520069	HOSE CLAMP NO 6 STAINLESS
28	2	914008	1/2UNC HEX STOVER NUT
29	1	900086	5/16UNC X 2 1/4 HEX BOLT
30	2	470118	1/4UNC X 3/4 FLANGE HEX BOLT
31	12	470121	1/4UNC HEX FLANGE LOCK NUT
32	1	316558	FAN SPACER, 3.00
33	1	316550	CUMM ENG,QSB5.9,205@2500 CMPSR
34	2	520067	HOSE CLAMP NO 28 STAINLESS
35	2	920004	1/2 SAE FLAT WASHER
36	1	520126	CUSH HOSE CLAMP 2IN X 5/8W
37	1	920501	5/16 LOCK WASHER
38	2	520099	HOSE CLAMP NO 40 STAINLESS
39	2	900271	1/2UNC X 3 1/4 HEX BOLT
40	4	473769	10MM-1.50 X 100MM FLG HEX BOLT
41	4	473799	10MM FLAT WASHER
42	1	316529	DRIVE BELT, QSB5.9 ENG 316550

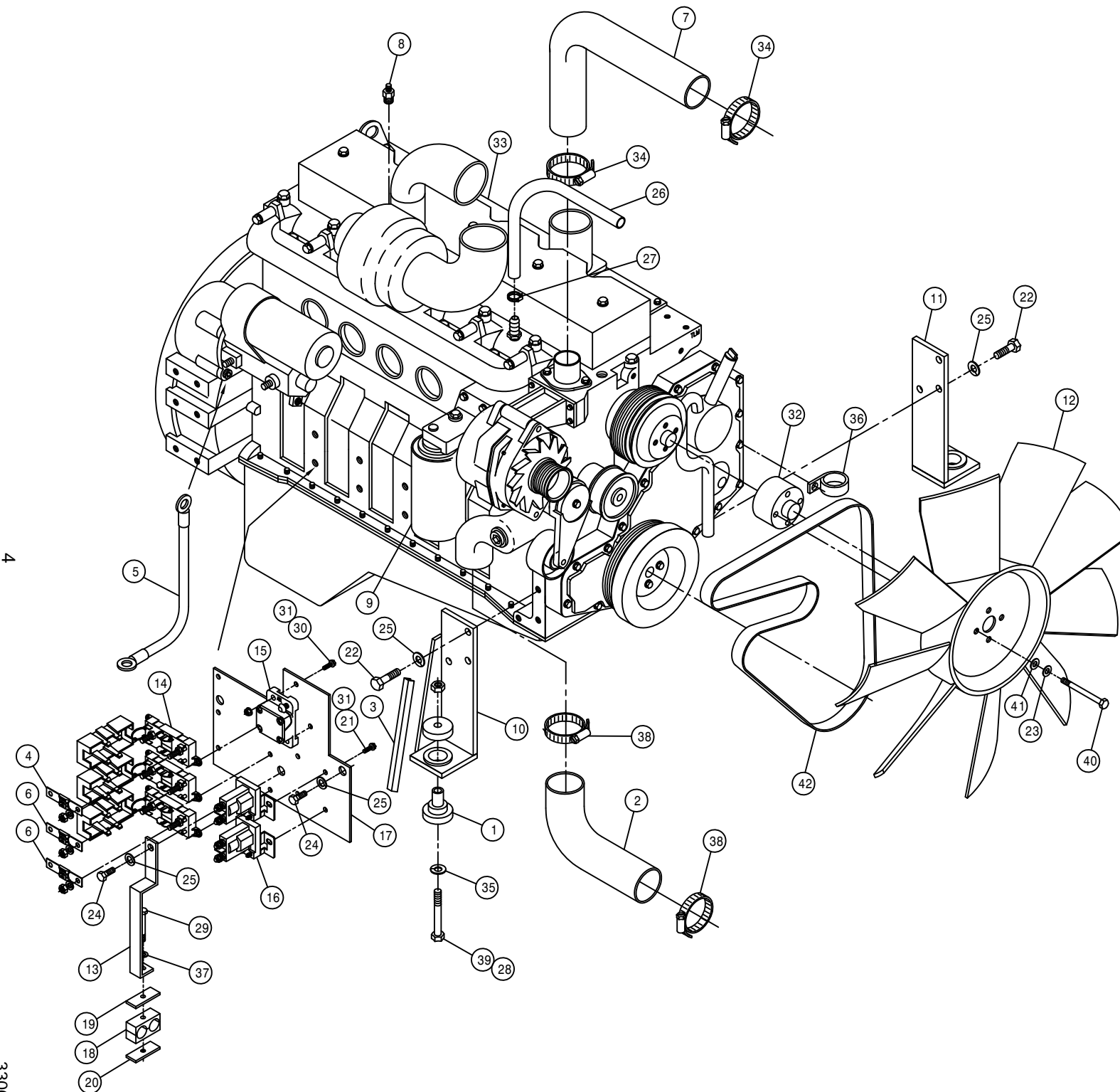

4

330004

ENGINE ASSEMBLY

DET. QTY PART NO. DESCRIPTION

1	1	470122	1/4UNC X 1/2 FLANGE HEX BOLT
2	1	316252	RH REAR ENG MT WLD, CUMM 94
3	1	316253	LH REAR ENG MT WLD, CUMM 94
4	2	473783	12MM-1.75 X 25MM HEX BOLT
5	1	316556	LWR AIR TUBE BRKT,ENG 2101 03
6	2	193012	QUICKEDGE TRIM .135 TO .250
7	1	316550	CUMM ENG,QSB5.9,205@2500 CMPSR
8	1	316337	LH HYD TUBE MT, 2100 98
9	1	316338	REAR HYD TUBE MT, 2100 98
10	1	470274	TUBE CLAMP BODY,.750-1.750
11	1	470275	TUBE CLAMP BODY,1.000-1.000
12	2	470278	CLAMP WELD PLATE, SNGL, 2.75LG
13	8	473775	12MM-1.75 X 30MM HEX BOLT
14	11	473784	12MM LOCK WASHER
15	11	473792	10MM-1.50 X 30MM HEX BOLT
16	12	473798	10MM LOCK WASHER
17	1	473818	10MM-1.50 X 40MM HEX BOLT
18	1	470121	1/4UNC HEX FLANGE LOCK NUT
19	1	601553	HOSE, 1/4 X 43 AIR
20	1	800502	PUMP DRIVE,DIRECT SAE#3/C 23T
21	1	800503	DRIVE DISK ASSY,11.5" 23T SPL
22	1	291674	OIL PRESS SENDER,125PSI,1/8NPT
23	1	900086	5/16UNC X 2 1/4 HEX BOLT
24	8	900128	3/8UNC X 3/4 HEX BOLT
25	1	520101	CUSH HOSE CLAMP, 1"D X 1/2W
26	1	711036	1/8MNPT-1/4 NYL TUBE FTG
27	8	920502	3/8 LOCK WASHER
28	4	920004	1/2 SAE FLAT WASHER
29	2	311054	RUBBER MOUNT SET, CB-2202-4
30	2	311055	REBOUND WASHER FOR 311054
31	2	520120	HOSE CLAMP NO 4 STAINLESS
32	2	920501	5/16 LOCK WASHER
33	2	914008	1/2UNC HEX STOVER NUT
34	1	900069	5/16UNC X 2" HEX BOLT
35	2	900271	1/2UNC X 3 1/4 HEX BOLT
36	1	473782	12MM-1.75 X 18MM HEX BOLT
37	1	711100	5/8 HOSE BARB-90-1/2MNPT BRS
38	1	470160	MUFFLER CLAMP 3.00 IN
39	1	601529	HOSE, 3/4 X 34 CLEAR VINYL
40	1	316373	FUEL/WATER SEPERATOR (316360)

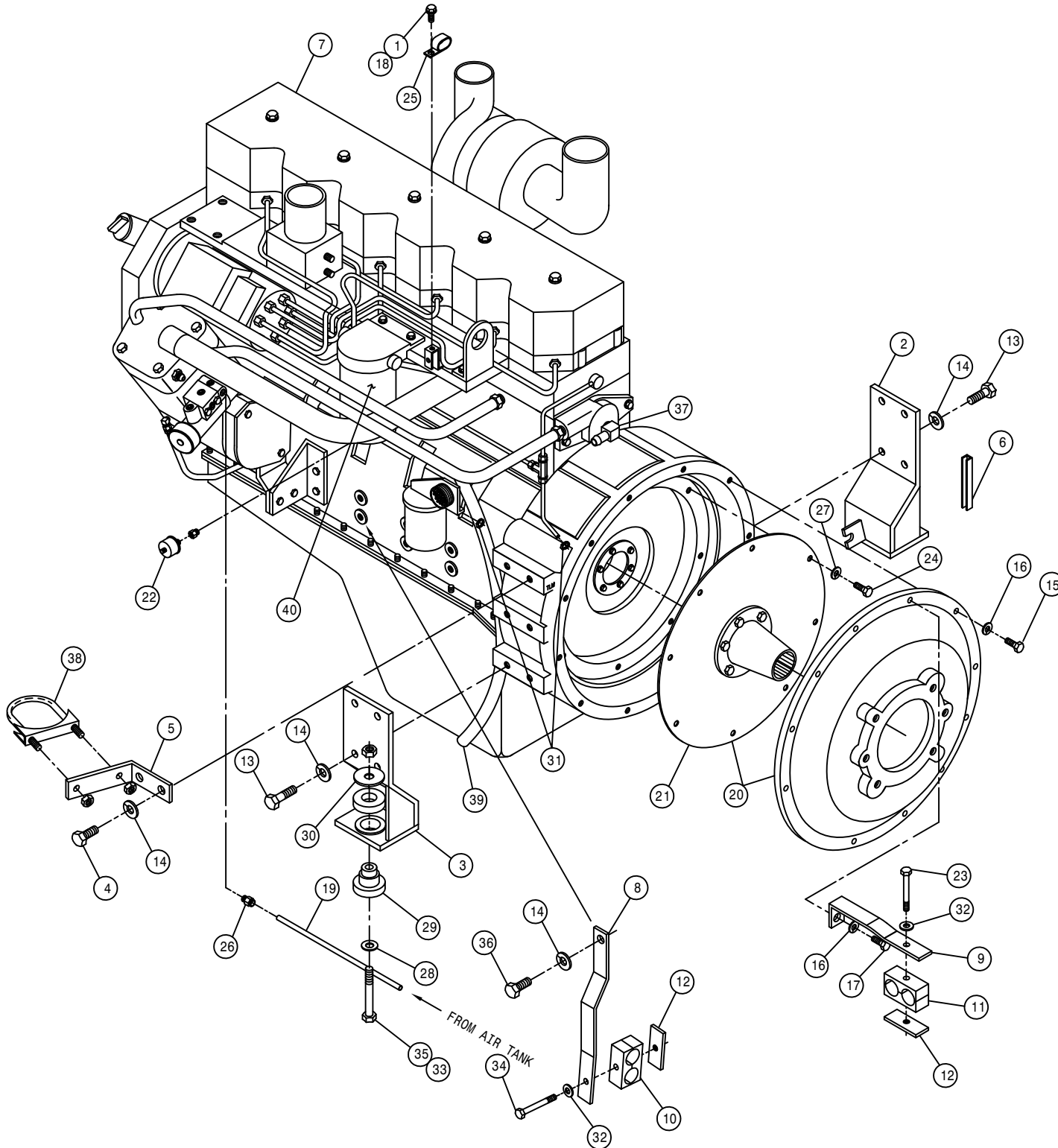

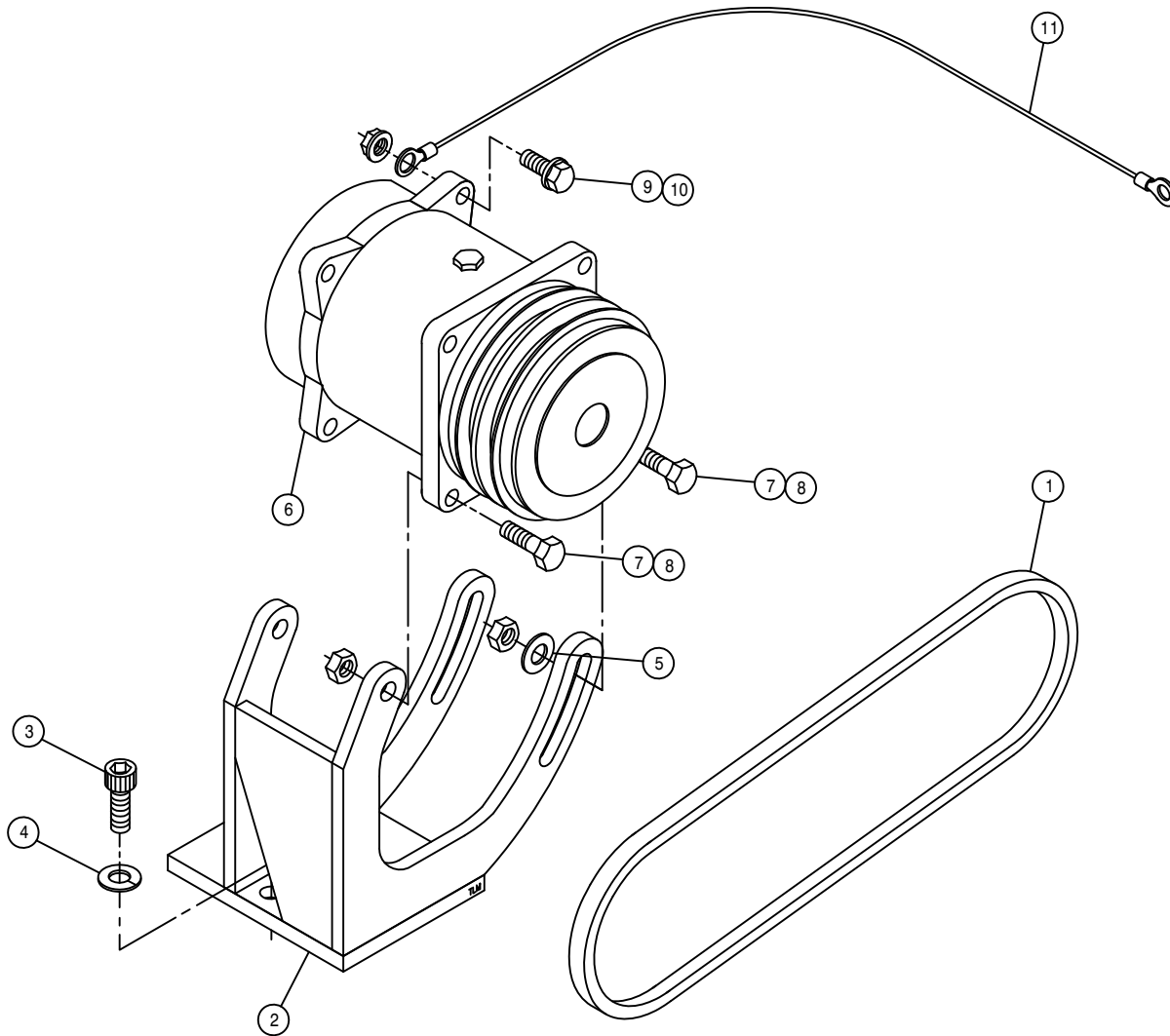

A/C COMPRESSOR PUMP ASSEMBLY

DET. QTY PART NO. DESCRIPTION

1	1	147049	BELT, 9425 GATES
2	1	316522	A/C MTG BRKT WLD, STS 2002
3	3	473844	10MM-1.50 X 30 SOC HD CAP SCR
4	3	473798	10MM LOCK WASHER
5	2	483043	3/8 REGULAR FLAT WASHER
6	1	657403	A/C COMP SR, 180D PORTS TM15/12
7	4	900131	3/8UNC X 1 1/2 HEX BOLT
8	4	914004	3/8UNC HEX STOVER NUT
9	1	470329	3/8UNC X 1 1/4 FLANGE HEX BOLT
10	1	470087	3/8UNC HEX FLANGE LOCK NUT
11	1	293564	16GA BLK-291512-291590-36

HYDROSTATIC PUMP ASSEMBLY

DET. QTY PART NO. DESCRIPTION

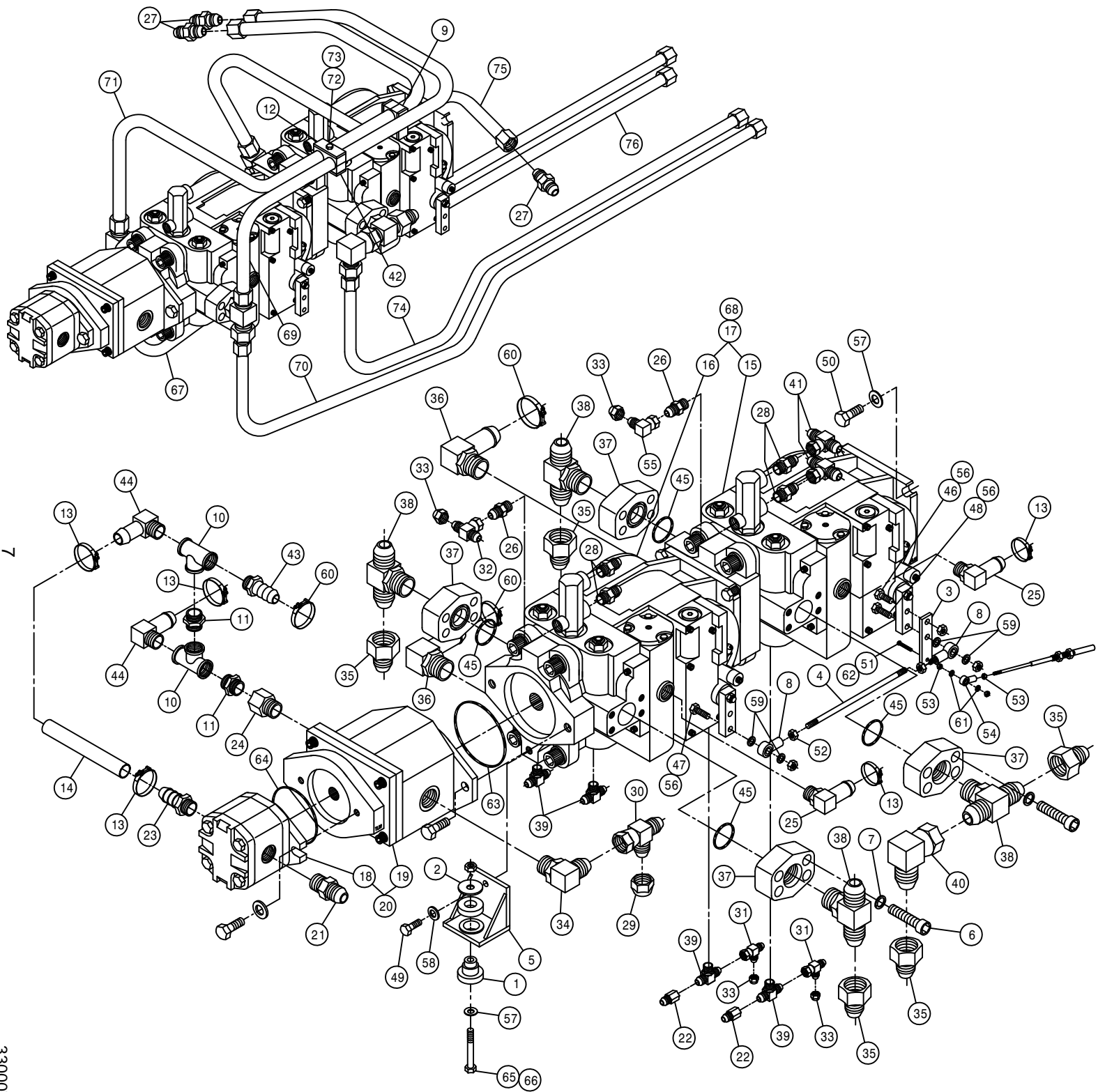

1	1	311054	RUBBER MOUNT SET, CB-2202-4
2	1	311055	REBOUND WASHER FOR 311054
3	1	316160	PUMP CONT LEVER EXT 280 CUMM
4	1	316335	HYDST PUMP CTRL ROD, 2100 98
5	1	316341	AUX PUMP SUPP MT WLD, 2100 98
6	16	470188	7/16-14 X 1 3/4 SKTHD CAP SCR
7	16	470189	7/16 HC LOCK WASH FOR 618598
8	2	473998	BALL JOINT, 1/4-28 1/4BORE
9	2	470275	TUBE CLAMP BODY, 1.000-1.000
10	2	505101	BLK PIPE TEE 1.00NPT
11	2	505105	1MNPT HEX PIPE NIPPLE STL
12	2	470276	CLAMP COVER PLATE, SNGL, 2.55LG
13	5	520137	1.12/1.25 T-BOLT HOSE CLAMP
14	1	601399	HOSE, 3/4 X 13 1FBR-1SPI
15	1	606231	SUND 75CC PUMP, C/C MT (.022)
16	1	606234	SUND 75CC PUMP, C/B MT (.022)
17	1	606230	TANDEM PUMP, 606231/606234 .022
18	1	606929	SUND GEAR PUMP .66CI, SPLINED
19	1	606932	SUND GEAR PUMP, 1.60CI, SPLINED
20	1	606941	TANDEM PUMP, 606929 & 606932
21	1	611126	7/8MJIC-7/8MOR ADPTR
22	2	618734	9/16JIC .047 ORIFICE ADPTR
23	1	618075	3/4 HOSE BARB- 1 1/16MOR
24	1	618090	1 5/16MOR-1FNPT ADPTR
25	2	618118	3/4 HOSE BARB-90-1 1/16MOR
26	2	618126	9/16MJIC-9/16MOR ADPTR
27	3	618577	1 5/16MJIC UNION
28	4	618327	3/4MJIC-7/8MOR ADPTR
29	1	618328	7/8FJIC CAP NUT
30	1	618333	7/8FJIC SW RUN TEE-7/8MJIC
31	2	618486	9/16FJIC SW RUN TEE-9/16MJIC
32	1	618514	9/16FJ SW BRANCH TEE-9/16MJ
33	4	618531	9/16FJIC CAP NUT
34	1	618535	7/8MJIC-90-1 1/16MOR LBO
35	5	618541	1 5/16FJIC-1 1/16MJIC ADPTR
36	2	618564	1IN HOSE BARB-90-1 5/16MOR
37	4	618598	1" 4-BOLT FLG X 1 5/16 FOR
38	4	618599	1 5/16MOR BRANCH TEE-1 5/16MJ
39	4	618629	9/16MOR BRANCH TEE-9/16MJIC
40	1	618640	1 5/16MJ-90-1 5/16FJ SWIV LBO
41	2	618643	3/4FJ SW BRANCH TEE-3/4MJ
42	2	470278	CLAMP WELD PLATE, SNGL, 2.75LG
43	1	714560	1NPT X 1 HOSE BARB
44	2	716000	3/4 HOSE BARB-90-1MNPT
45	4	870219	BUNA ORING 1 5/16 X 1 9/16
46	1	900003	1/4UNC X 1" HEX BOLT
47	1	900004	1/4UNC X 1 1/4 HEX BOLT
48	1	900005	1/4UNC X 1 1/2 HEX BOLT
49	1	900263	1/2UNC X 1" HEX BOLT
50	4	900265	1/2UNC X 1 1/2 HEX BOLT
51	1	903893	10-32 X 1" SLT RD HD MACH SCR
52	2	910001	1/4UNF HEX NUT
53	2	910027	10-32 HEX NUT
54	1	473921	BALL JOINT NO 10-32 THD
55	1	618618	9/16MJIC-90-9/16FJIC SWIV LBO
56	3	914000	1/4UNC HEX STOVER NUT
57	5	920004	1/2 SAE FLAT WASHER
58	1	920504	1/2 LOCK WASHER
59	4	920500	1/4 LOCK WASHER
60	3	520138	1.38/1.56 T-BOLT HOSE CLAMP
61	3	920510	#10 LOCK WASHER
62	1	914027	10-32 HEX STOVER NUT
63	1	606870	O-RING FOR 606865 SUND B-MT
64	1	606924	O-RING FOR SUND A-MT
65	1	900271	1/2UNC X 3 1/4 HEX BOLT
66	1	914008	1/2UNC HEX STOVER NUT
67	1	615723	LH REAR PUMP LWR TUBE ASSY 98
68	1	606950	O-RING, SUND 9004100-0480
69	1	615720	RH REAR PUMP UPR TUBE ASSY 98
70	1	615721	RH REAR PUMP LWR TUBE ASSY 98
71	1	615722	LH REAR PUMP UPR TUBE ASSY 98
72	2	900086	5/16UNC X 2 1/4 HEX BOLT
73	2	920501	5/16 LOCK WASHER
74	1	615717	RH FRT PUMP LWR TUBEASSY210098
75	1	615718	LH FRT PUMP UPR TUBEASSY210098
76	1	615719	LH FRT PUMP LWR TUBEASSY210098

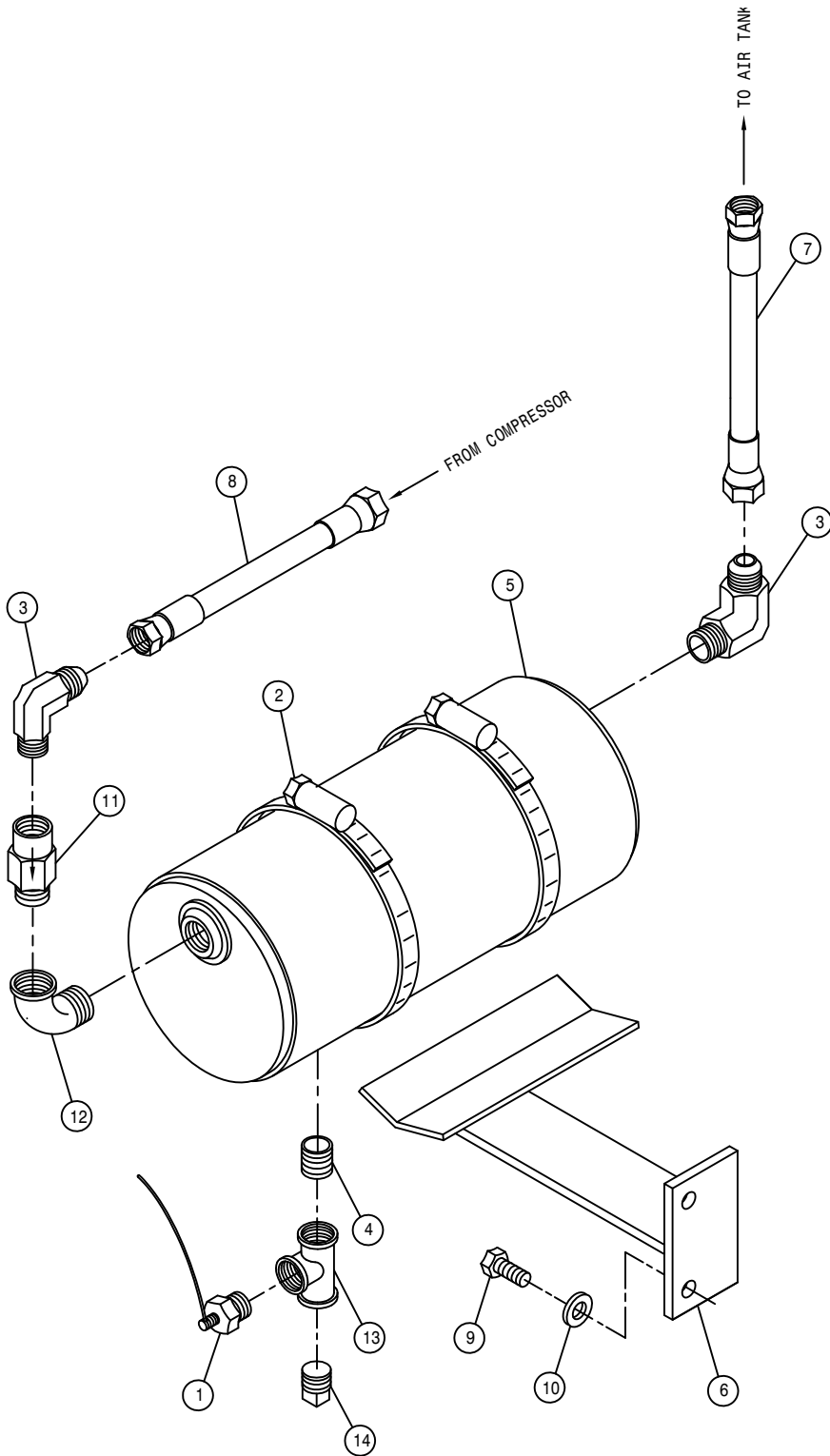

AIR WET TANK ASSEMBLY

DET.	QTY	PART NO.	DESCRIPTION	
	1	470266	DRAIN VALVE KIT, 1/4NPT	
	2	520086	HOSE CLAMP NO 88 STAINLESS	
	3	611145	3/4MJIC-90-1/2MNPT LBO	
	4	501601	CLOSE NIPPLE .25NPT	
	5	701115	WET TANK WLD	
	6	701220	WET TANK MT BRKT WLD,2101	98
	7	615624	06C1T-08FJX-08FJX-28	H/A
	8	611304	08P919-08FJX-10FJX-16	H/A
	9	473783	12MM-1.75 X 25MM HEX BOLT	
	10	473784	12MM LOCK WASHER	
	11	711032	CHECK VALVE, 1/2"FNPT-1/2"MNPT	
	12	503400	BLK PIPE ST EL 90DEG .50NPT	
	13	501101	BLK PIPE TEE .25NPT	
	14	501102	1/4 PIPE PLUG	

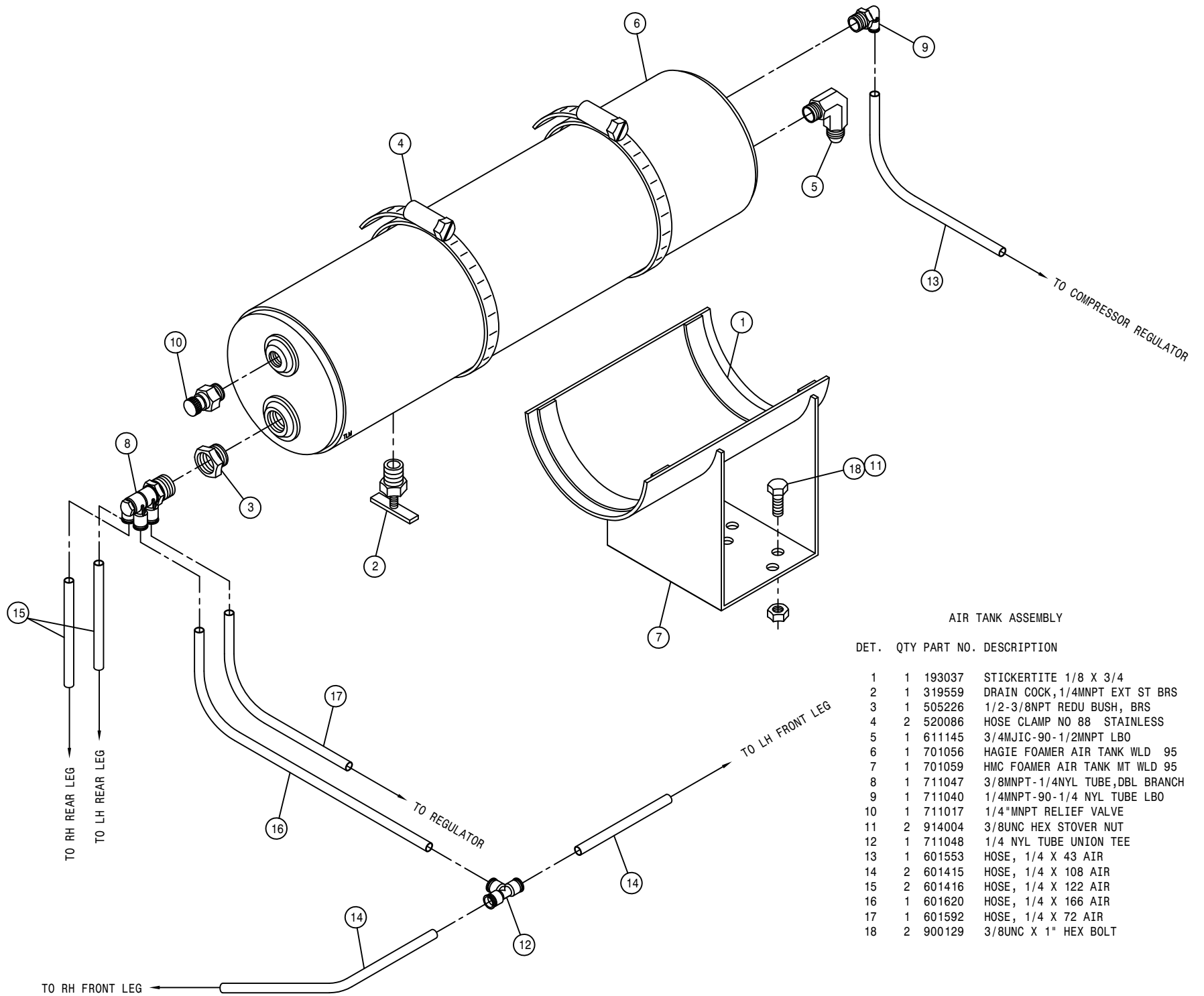

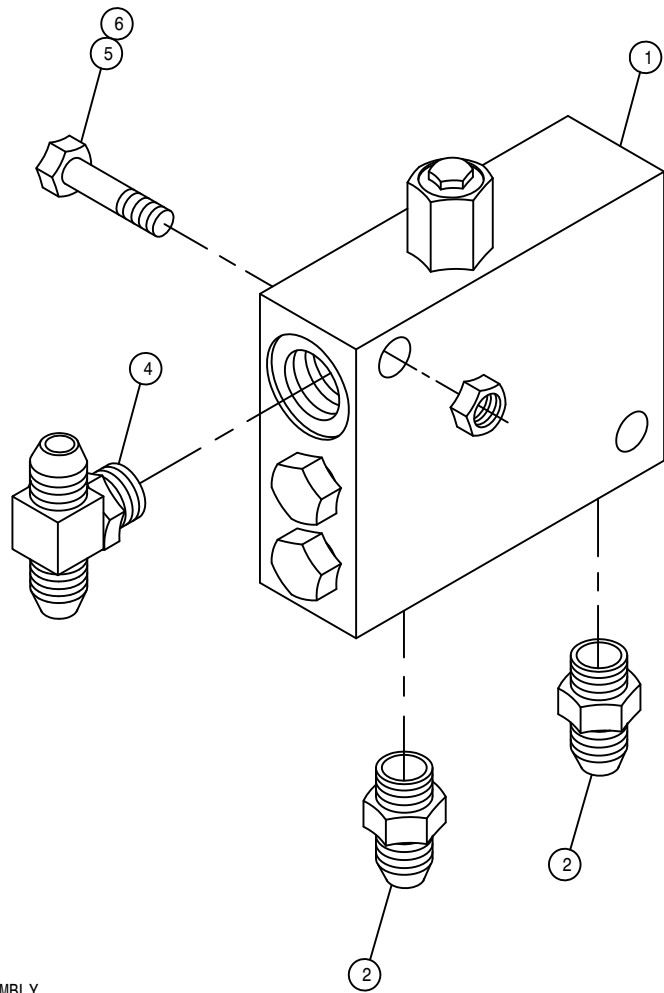
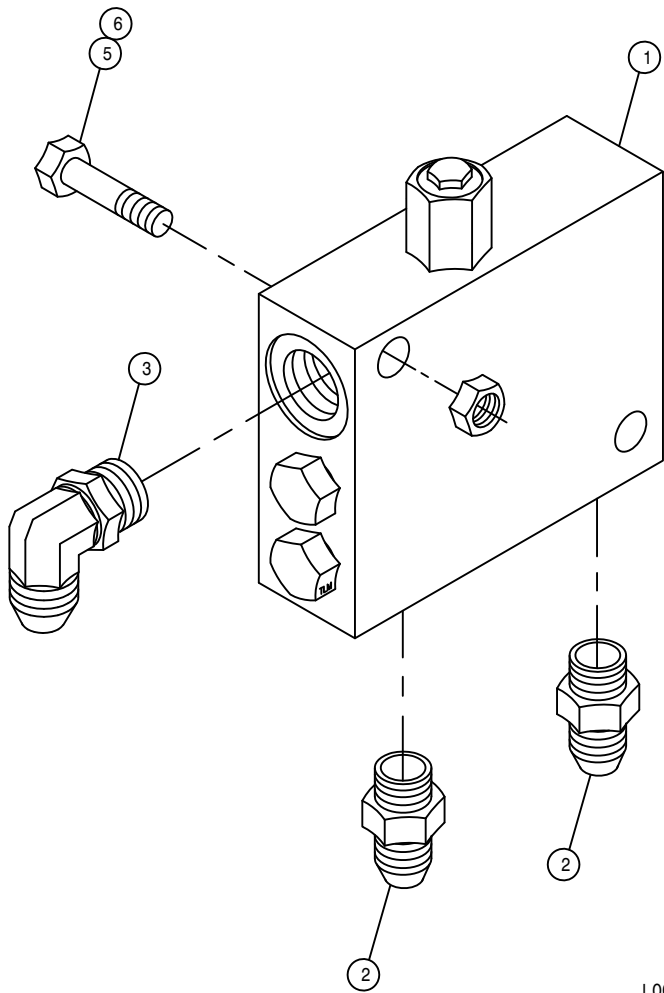

LOOP FLUSHING VALVE ASSEMBLY

DET. QTY PART NO. DESCRIPTION

1	2	610580	REMOTE FLUSHING VALVE, SUND
2	4	618126	9/16MJIC-9/16MOR ADPTR
3	1	618119	9/16MJIC-90-9/16MOR LBO
4	1	618629	9/16MOR BRANCH TEE-9/16MJIC
5	4	900133	3/8UNC X 2" HEX BOLT
6	4	914004	3/8UNC HEX STOVER NUT

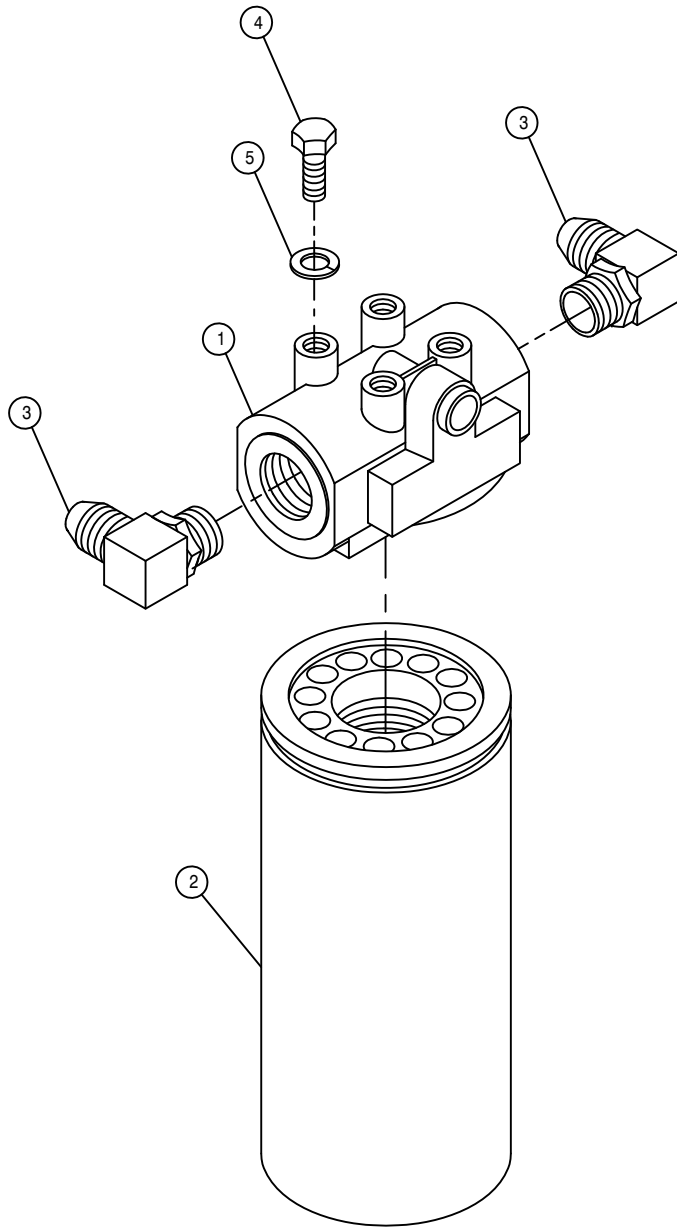

HI-PRESS FILTER ASSEMBLY

DET. QTY PART NO. DESCRIPTION

1	1	605608	HYD FILTER HEAD, DONALDSON
2	1	605609	HYD FILTER ELEMENT, DONALDSON
3	2	618474	3/4MJIC-90-1 1/16MOR LBO
4	4	900128	3/8UNC X 3/4 HEX BOLT
5	4	920502	3/8 LOCK WASHER

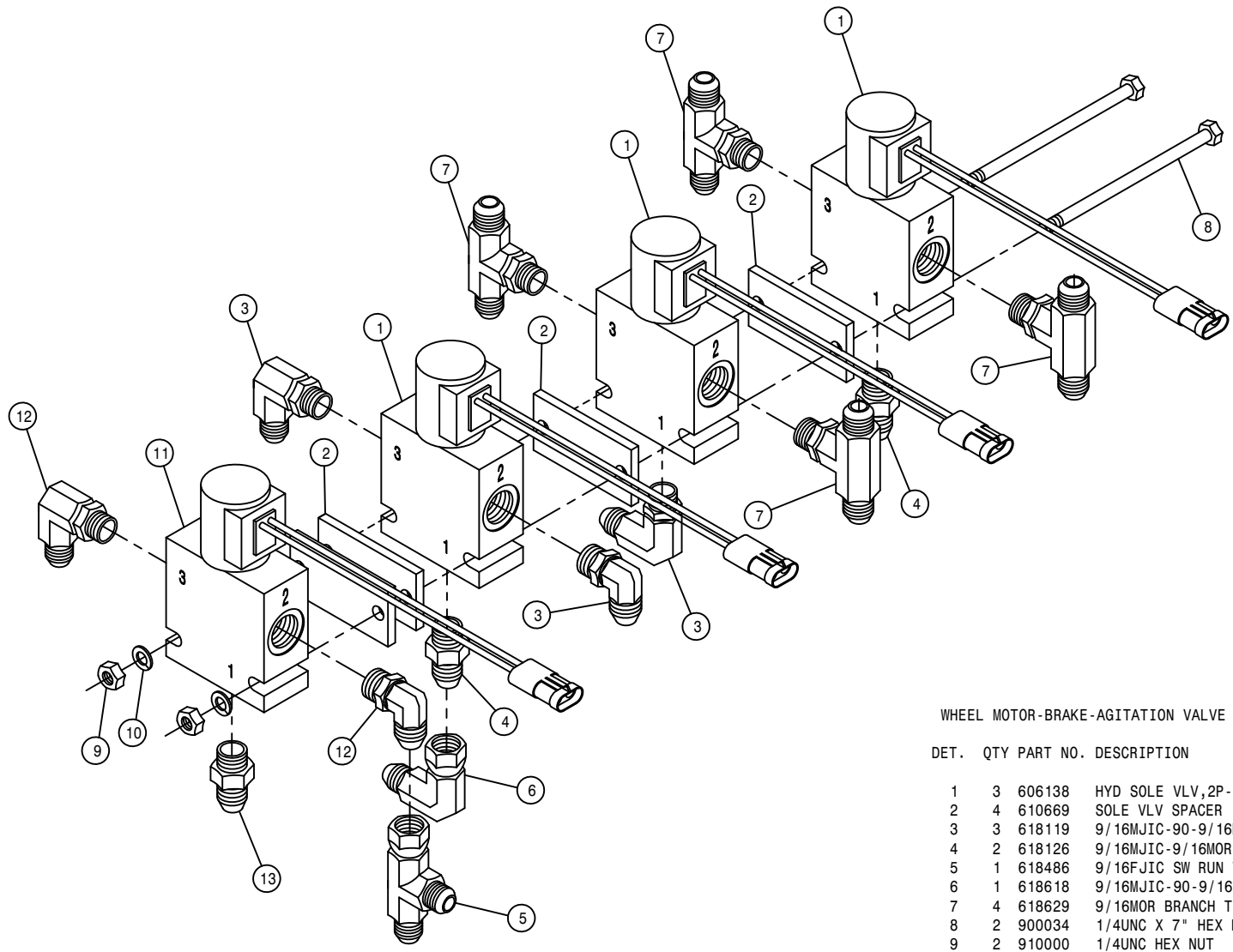

WHEEL MOTOR-BRAKE-AGITATION VALVE ASSEMBLY

DET.	QTY	PART NO.	DESCRIPTION
1	3	606138	HYD SOLE VLV,2P-3W,9/16FOR, WP
2	4	610669	SOLE VLV SPACER
3	3	618119	9/16MJIC-90-9/16MOR LBO
4	2	618126	9/16MJIC-9/16MOR ADPTR
5	1	618486	9/16FJIC SW RUN TEE-9/16MJIC
6	1	618618	9/16MJIC-90-9/16FJIC SWIV LBO
7	4	618629	9/16MOR BRANCH TEE-9/16MJIC
8	2	900034	1/4UNC X 7" HEX BOLT
9	2	910000	1/4UNC HEX NUT
10	2	920500	1/4 LOCK WASHER
11	1	606139	HYD SOLE VLV,2P3W,3/4FOR, WP
12	2	618115	9/16MJIC-90-3/4MOR LBO
13	1	618109	9/16MJIC-3/4MOR ADPTR

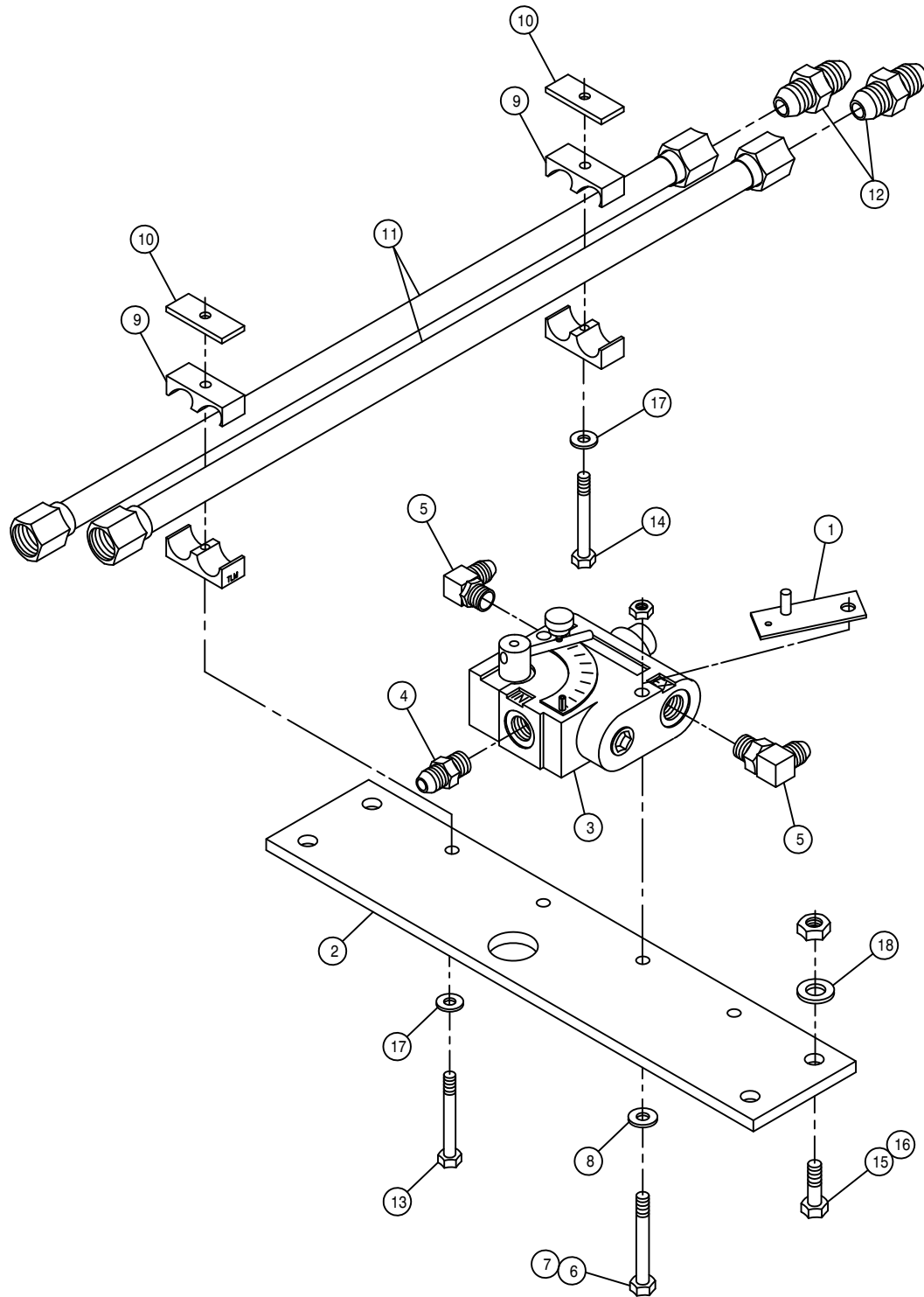

SOLUTION PUMP VARIABLE FLOW CONTROL ASSEMBLY

DET. QTY PART NO. DESCRIPTION

1	1	342306	SOLU PUMP VFC STOP WLD,9G 96
2	1	361477	TIE PLT, 2100 98
3	1	606818	FLO CONT FCR51 0-16GPM 7/8FOR
4	1	611126	7/8MJIC-7/8MOR ADPTR
5	2	611128	7/8MJIC-90-7/8MOR LBO
6	2	900009	1/4UNC X 2 3/4 HEX BOLT
7	2	914000	1/4UNC HEX STOVER NUT
8	2	920000	1/4 SAE FLAT WASHER
9	4	470274	TUBE CLAMP BODY, .750-.750
10	4	470278	CLAMP WELD PLATE, SNGL, 2.75LG
11	4	615724	FRT MAIN HYD TUBE ASSY,2100 98
12	4	618177	1 1/16MJIC UNION
13	2	900069	5/16UNC X 2" HEX BOLT
14	2	900086	5/16UNC X 2 1/4 HEX BOLT
15	4	900265	1/2UNC X 1 1/2 HEX BOLT
16	4	914008	1/2UNC HEX STOVER NUT
17	4	920001	5/16 SAE FLAT WASHER
18	4	920004	1/2 SAE FLAT WASHER

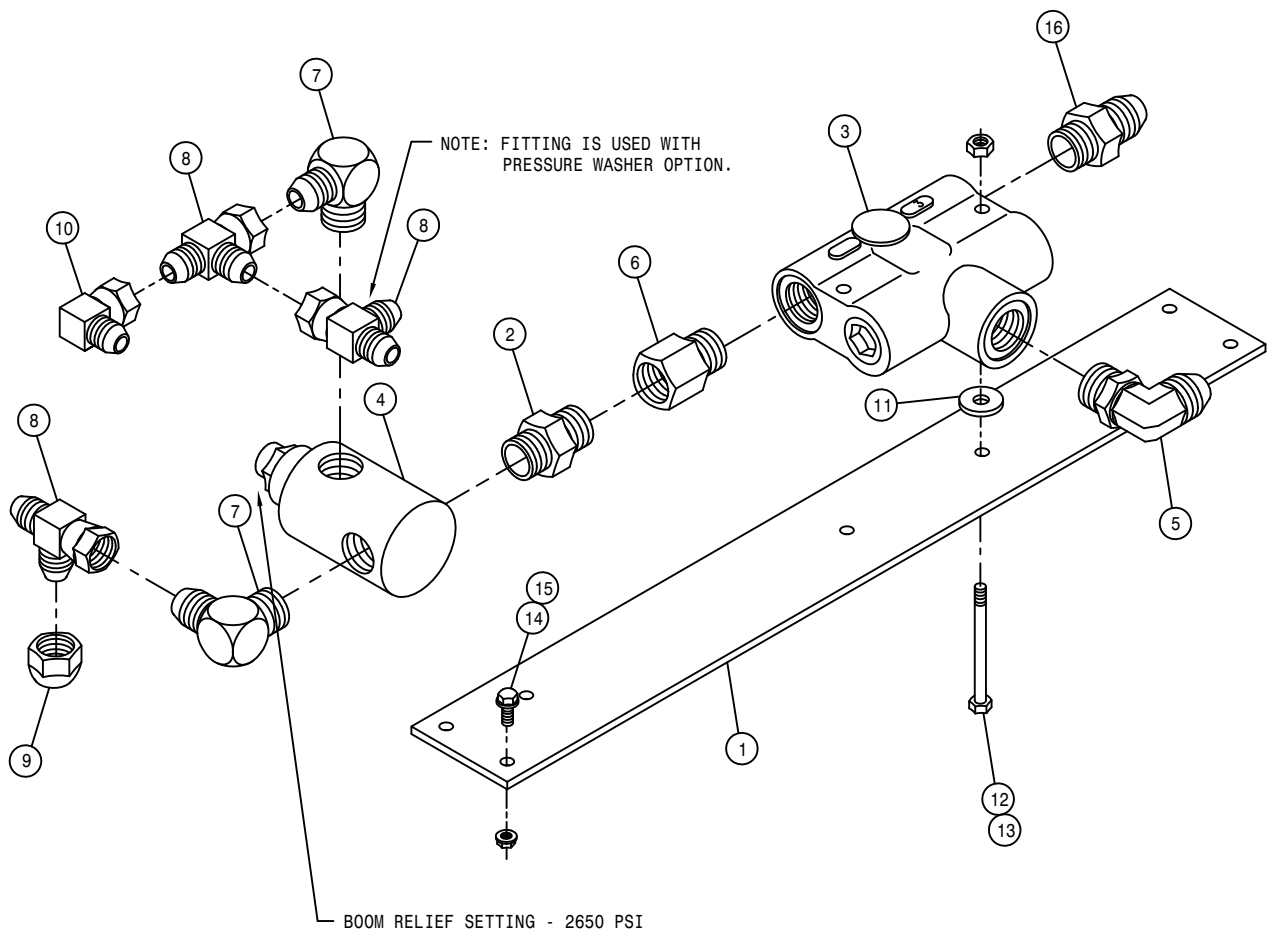

FLOW DIVIDER VALVE ASSEMBLY

DET.	QTY	PART NO.	DESCRIPTION
1	1	361478	REAR FLOW DIV PLT, 2100 98
2	1	500000	1/2MNPT HEX PIPE NIPPLE STL
3	1	610307	FLO DIV BG53 3GPM PRI 7/8FOR
4	1	607512	RELIEF VALVE, RL50, 1850 PSI
5	1	611128	7/8MJIC-90-7/8MOR LBO
6	1	618072	7/8MOR-1/2FNPT ADPTR
7	2	618107	9/16MJIC-90-1/2MNPT LBO
8	3	618486	9/16FJIC SW RUN TEE-9/16MJIC
9	1	618531	9/16FJIC CAP NUT
10	1	618618	9/16MJIC-90-9/16FJIC SWIV LBO
11	2	748500	RUBER WASH 3/8X1/4IDX1 1/2 OD
12	2	900008	1/4UNC X 2 1/2 HEX BOLT
13	2	914000	1/4UNC HEX STOVER NUT
14	4	470118	1/4UNC X 3/4 FLANGE HEX BOLT
15	4	470121	1/4UNC HEX FLANGE LOCK NUT
16	1	618310	9/16MJIC-7/8MOR ADPTR

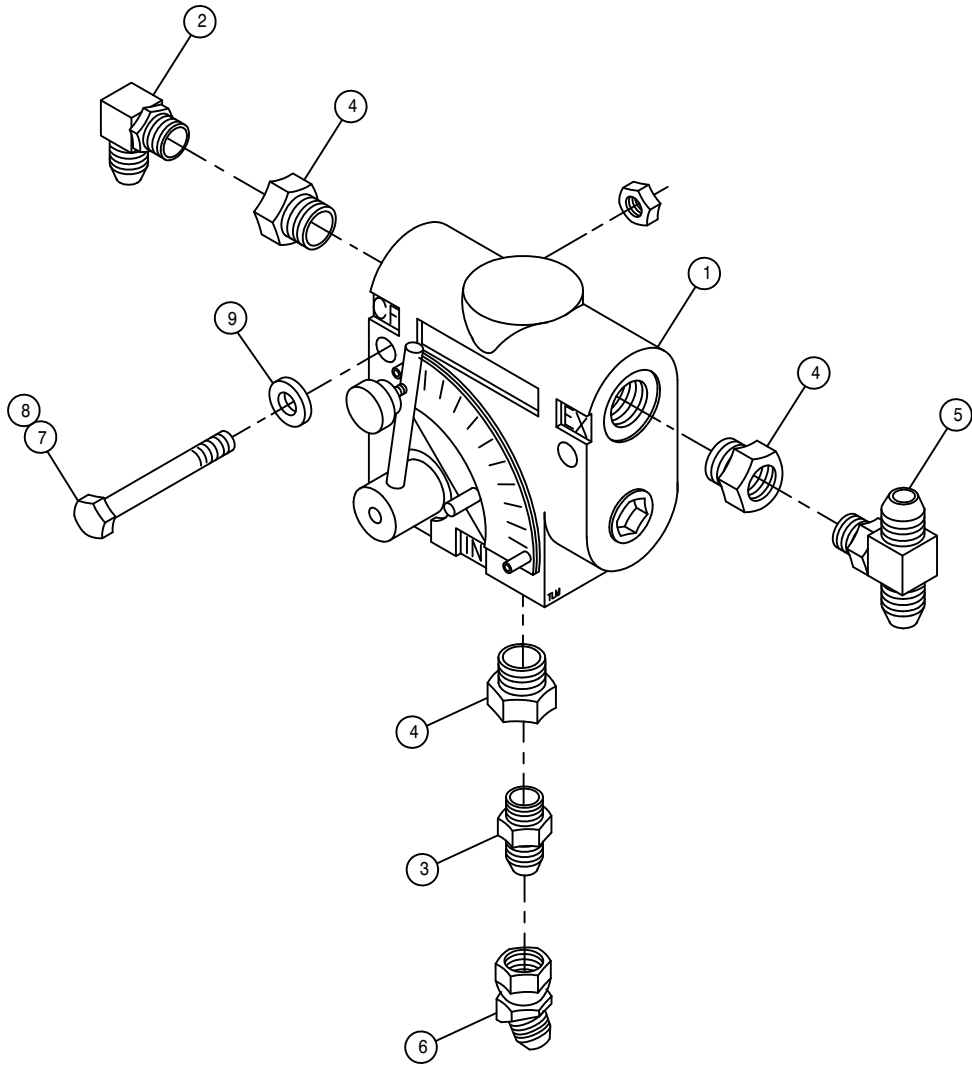

AGITATOR VARIABLE FLOW CONTROL ASSEMBLY

DET.	QTY	PART NO.	DESCRIPTION
1	1	606827	FLO CONT FC51 0-3 VARI 7/8FOR
2	1	618119	9/16MJIC-90-9/16MOR LBO
3	1	618126	9/16MJIC-9/16MOR ADPTR
4	3	618172	7/8MOR-9/16FOR ADPTR
5	1	618629	9/16MOR BRANCH TEE-9/16MJIC
6	1	618634	9/16MJIC-45-9/16FJIC SWIV LBO
7	2	900008	1/4UNC X 2 1/2 HEX BOLT
8	2	914000	1/4UNC HEX STOVER NUT
9	2	470212	1/4 BONDED SEALING WASH, SS

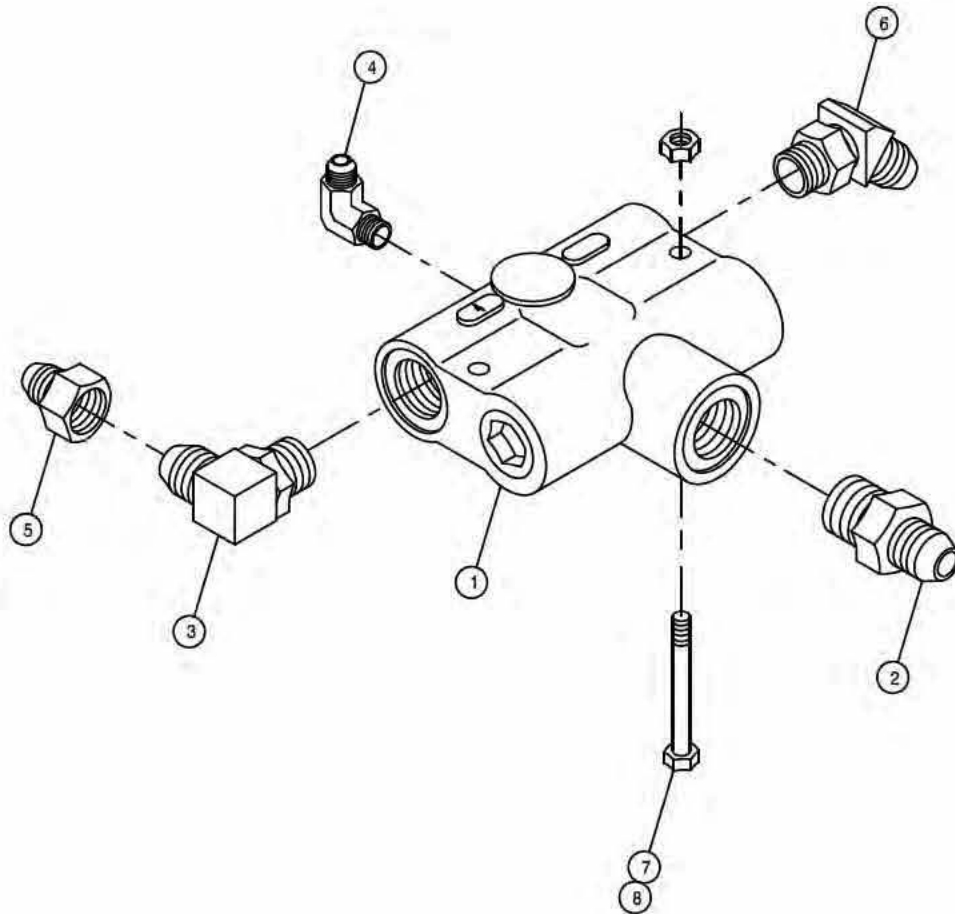

BGR56 FLOW DIVIDER ASSEMBLY

DET. QTY PART NO. DESCRIPTION

DET.	QTY	PART NO.	DESCRIPTION
1	1	607528	FLO DIV BGR54 4GPM PRI 7/8FOR
2	1	611126	7/8MJIC-7/8MOR ADPTR
3	1	611128	7/8MJIC-90-7/8MOR LBO
4	1	618015	9/16MJIC-90-3/8MNPT LBO
5	1	618557	7/8FJIC-9/16MJIC ADPTR
6	1	618644	7/8MJIC-45-7/8MOR LBO
7	2	900008	1/4UNC X 2 1/2 HEX BOLT
8	2	914000	1/4UNC HEX STOVER NUT

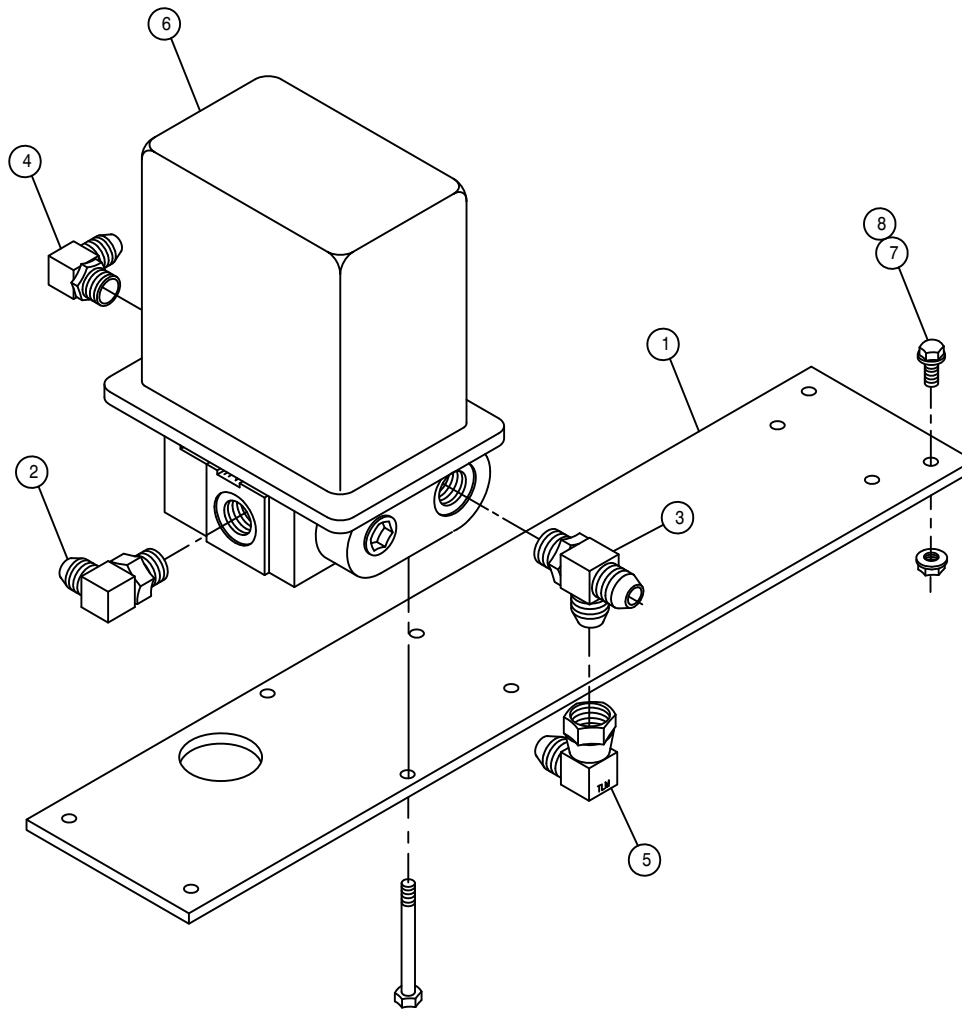

RAVEN HYDRAULIC CONTROL VALVE ASSEMBLY

DET.	QTY	PART NO.	DESCRIPTION	
	1	361476	ELECT VLV MTG PLT, 2100	98
	2	611128	7/8MJIC-90-7/8MOR LBO	
	3	618130	7/8MOR RUN TEE-7/8MJIC	
	4	618183	3/4MJIC-90-7/8MOR LBO	
	5	618301	7/8MJIC-90-7/8FJIC SWIV LBO	
	6	690621	VALVE HYD CTRL,16GPM RAVEN	
	7	470118	1/4UNC X 3/4 FLANGE HEX BOLT	
	8	470121	1/4UNC HEX FLANGE LOCK NUT	

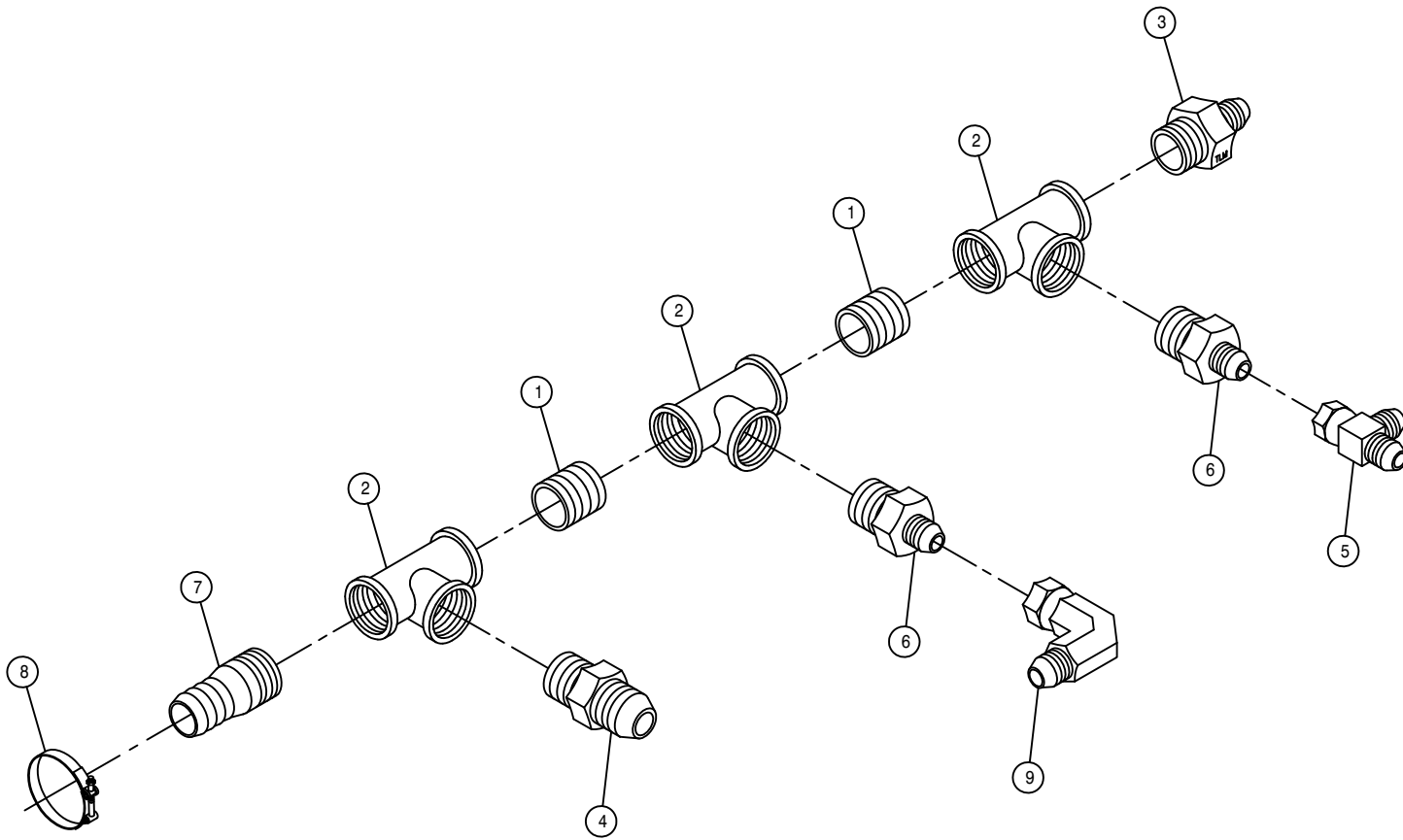

RETURN TEE ASSEMBLY

DET. QTY PART NO. DESCRIPTION

1	2	504702	CLOSE NIPPLE .75NPT
2	3	504955	BLK PIPE TEE .75NPT
3	1	610300	3/4MJIC-3/4MNPT ADPTR
4	1	618059	7/8MJIC-3/4MNPT ADPTR
5	1	618486	9/16FJIC SW RUN TEE-9/16MJIC
6	2	618642	9/16MJIC-3/4MNPT ADPTR
7	1	713220	HOSE BARB 3/4 NPT X 3/4
8	1	520137	1.12/1.25 T-BOLT HOSE CLAMP
9	1	618618	9/16MJIC-90-9/16FJIC SWIV LBO

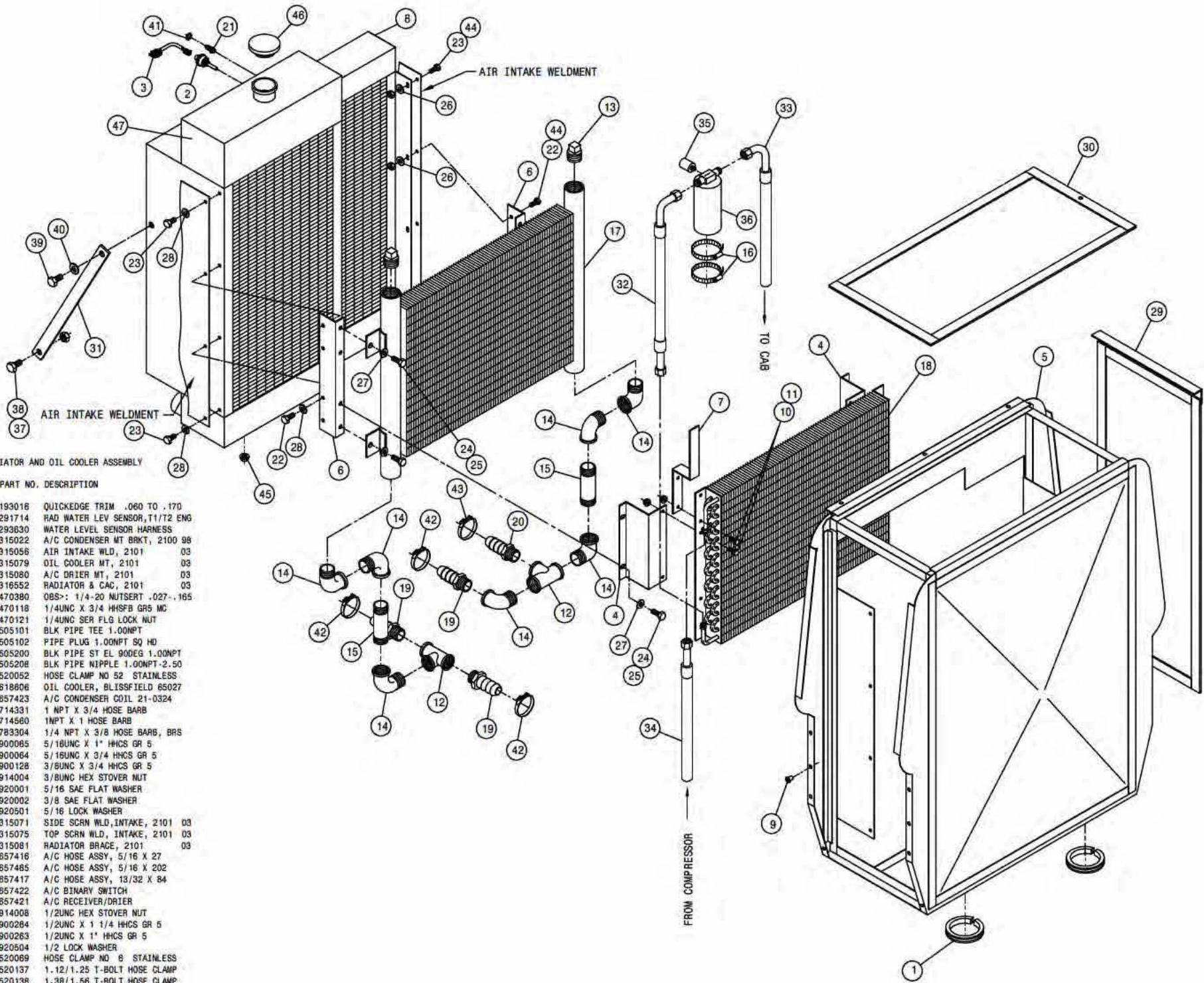

RADIATOR AND OIL COOLER ASSEMBLY

DET. QTY PART NO. DESCRIPTION

1	2	193018	QUICKEDGE TRIM .060 TO .170
2	1	291714	RAD WATER LEV SENSOR, T11/T2 ENG
3	1	293630	WATER LEVEL SENSOR HARNESS
4	2	316022	A/C CONDENSER MT BRKT, 2100 98
5	1	315056	AIR INTAKE WLD, 2101 03
6	2	315079	OIL COOLER MT, 2101 03
7	1	315080	A/C DRIER MT, 2101 03
8	1	316552	RADIATOR & CAC, 2101 03
9	16	470380	OBS-> 1/4-20 NUTSERT .027-.165
10	6	470118	1/4UNC X 3/4 HHFSB GR5 MC
11	6	470121	1/4UNC SER FLG LOCK NUT
12	2	505101	BLK PIPE TEE 1.00NPT
13	2	505102	PIPE PLUG 1.00NPT SQ HD
14	7	505200	BLK PIPE ST EL 90DEG 1.00NPT
15	2	505208	BLK PIPE NIPPLE 1.00NPT-2.50
16	2	520052	HOSE CLAMP NO 52 STAINLESS
17	1	618606	OIL COOLER, BLISSFIELD 65027
18	1	657423	A/C CONDENSER COIL 21-0324
19	3	714331	1 NPT X 3/4 HOSE BARB
20	1	714560	1NPT X 1 HOSE BARB
21	1	783304	1/4 NPT X 3/8 HOSE BARB, BR5
22	4	900065	5/16UNC X 1" HHCS GR 5
23	4	900064	5/16UNC X 3/4 HHCS GR 5
24	6	900128	3/8UNC X 3/4 HHCS GR 5
25	8	914004	3/8UNC HEX STOVER NUT
26	4	920001	5/16 SAE FLAT WASHER
27	8	920002	3/8 SAE FLAT WASHER
28	4	920501	5/16 LOCK WASHER
29	2	315071	SIDE SCR NLD, INTAKE, 2101 03
30	1	315075	TOP SCR NLD, INTAKE, 2101 03
31	2	315081	RADIATOR BRACE, 2101 03
32	1	657416	A/C HOSE ASSY, 5/16 X 27
33	1	657485	A/C HOSE ASSY, 5/16 X 202
34	1	657417	A/C HOSE ASSY, 13/32 X 84
35	1	657422	A/C BINARY SWITCH
36	1	657421	A/C RECEIVER/DRIER
37	2	914008	1/2UNC HEX STOVER NUT
38	2	900284	1/2UNC X 1 1/4 HHCS GR 5
39	2	900263	1/2UNC X 1" HHCS GR 5
40	2	920504	1/2 LOCK WASHER
41	1	520069	HOSE CLAMP NO 6 STAINLESS
42	3	520137	1-12/1.25 T-BOLT HOSE CLAMP
43	1	520138	1-38/1.56 T-BOLT HOSE CLAMP
44	4	914002	5/16UNC HEX STOVER NUT
45	2	470360	1/2UNC SER FLG HEX NUT
46	1	316377	RAD CAP, 10LB 10237
47	1	316560	RADIATOR, 03-04 2101, 05-08 DT5

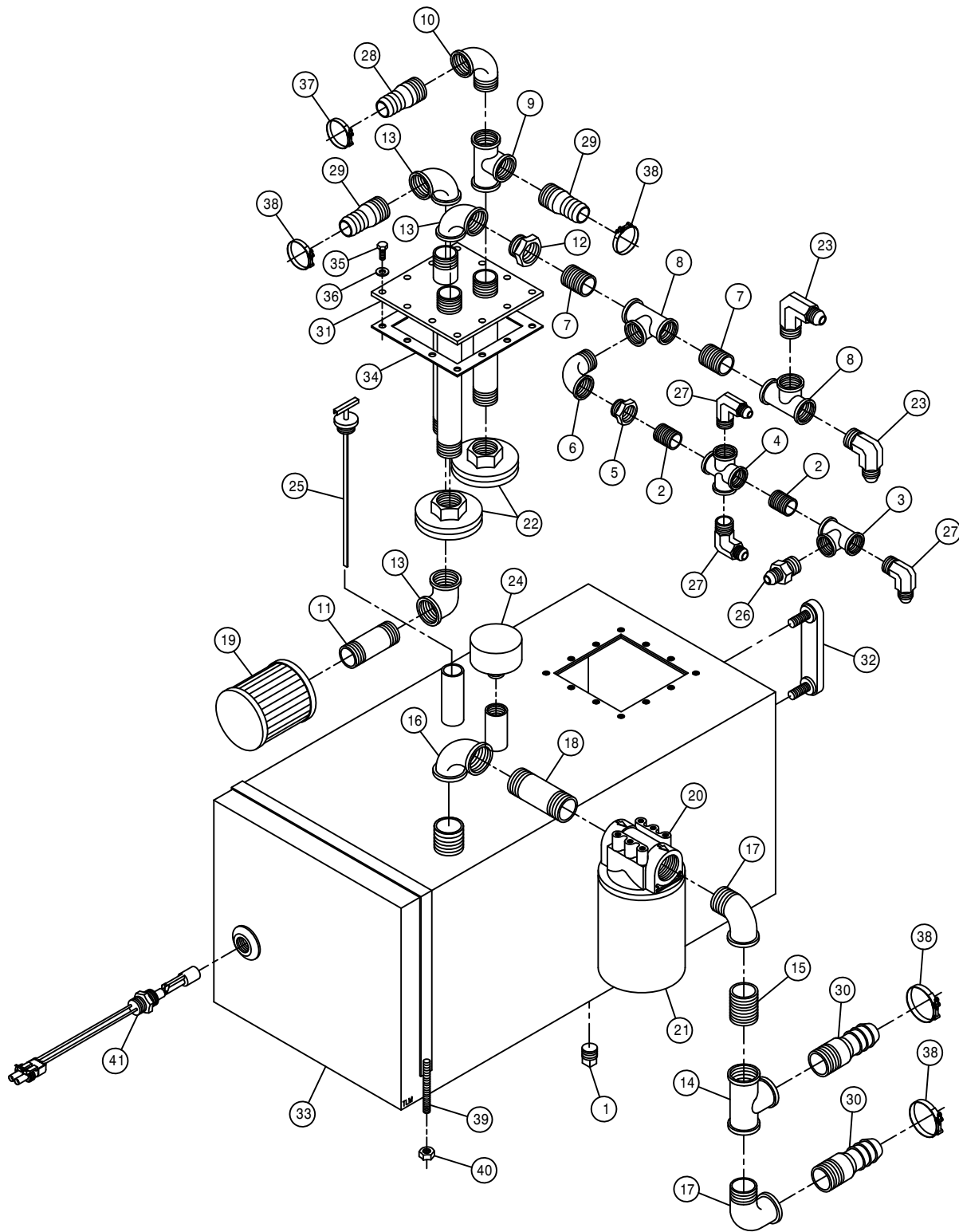

HYDRAULIC TANK ASSEMBLY

DET.	QTY	PART NO.	DESCRIPTION
	1	470308	1/2MNPT DRAIN PLUG,AL HD,MAG
	2	503600	CLOSE NIPPLE .50NPT
	3	503820	BLK PIPE TEE .50NPT
	4	503824	BLK PIPE CROSS .50NPT
	5	504210	RED BUSH 3/4 NPT X 1/2 NPT
	6	504610	BLK PIPE ST EL 90DEG .75NPT
	7	504702	CLOSE NIPPLE .75NPT
	8	504955	BLK PIPE TEE .75NPT
	9	505101	BLK PIPE TEE 1.00NPT
	10	505200	BLK PIPE ST EL 90DEG 1.00NPT
	11	505203	BLK PIPE NIPPLE 1.00NPT-4.00
	12	505213	RED BUSH 1 X 3/4 BLK MAL
	13	505300	BLK PIPE EL 90DEG 1.00NPT
	14	506105	BLK PIPE TEE 1.25NPT
	15	506200	CLOSE NIPPLE 1.25NPT
	16	506303	BLK PIPE EL 90DEG 1.25NPT
	17	506410	BLK PIPE ST EL 90DEG 1.25NPT
	18	506604	BLK PIPE NIPPLE 1.25NPT-4.00
	19	605600	TANK FILTER, 100 MESH,1"FNPT
	20	605601	PARKER FILTER ASSY,10M,1.25NPT
	21	605602	PARKER FILTER ELEMENT,10MICRON
	22	605603	LINE SUMP DIFFUSER
	23	610305	3/4MJIC-90-3/4MNPT LBO
	24	611052	FILLER BREATHER 3/4NPT
	25	614453	DIPSTICK, 8IN
	26	618018	9/16MJIC-1/2MNPT ADPTR
	27	618107	9/16MJIC-90-1/2MNPT LBO
	28	714331	1 NPT X 3/4 HOSE BARB
	29	714560	1NPT X 1 HOSE BARB
	30	715664	1 1/4 NPT X 1 HOSE BARB
	31	760090	RECEIVER PLT WLD 8240
	32	760177	SIGHT GAUGE W/TEMP, HYD TANK
	33	760268	HYD TANK WLD, 2100 2002
	34	763039	HYD MTR MTG PLT GSKT
	35	900064	5/16UNC X 3/4 HEX BOLT
	36	920001	5/16 SAE FLAT WASHER
	37	520137	1.12/1.25 T-BOLT HOSE CLAMP
	38	520138	1.38/1.56 T-BOLT HOSE CLAMP
	39	760212	HYD TANK STRAP WLD, 2100 98
	40	914004	3/8UNC HEX STOVER NUT
	41	470350	LIQUID LEVEL SWITCH ASSY,1/2NP

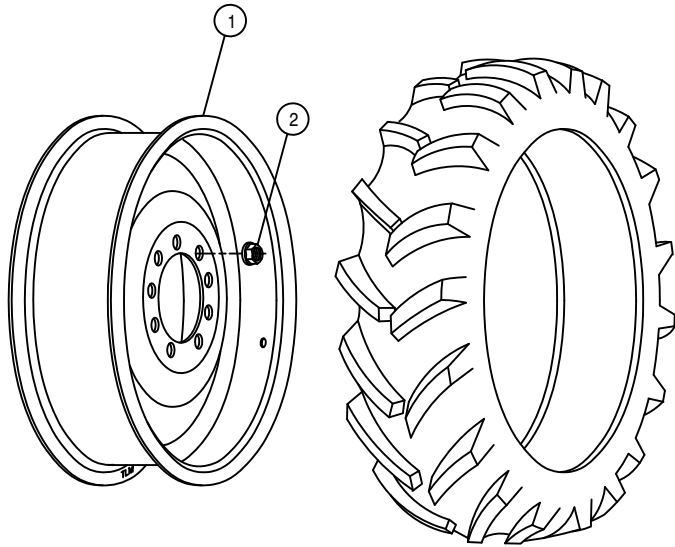

290/95R 34 *** RADIAL TIRE

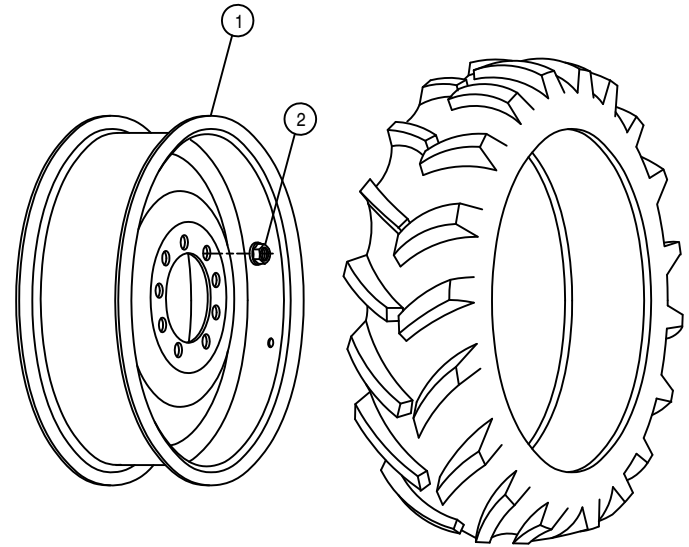

320/85R 34 *** RADIAL TIRE

TIRE AND RIM ASSEMBLIES

DET. QTY PART NO. DESCRIPTION

1	2	821042	RIM WLD, W10-34	98
2	18	470140	5/8UNF HEX SMTH FLANGE NUT PLT	

RIGHT FRONT LEG ASSEMBLY

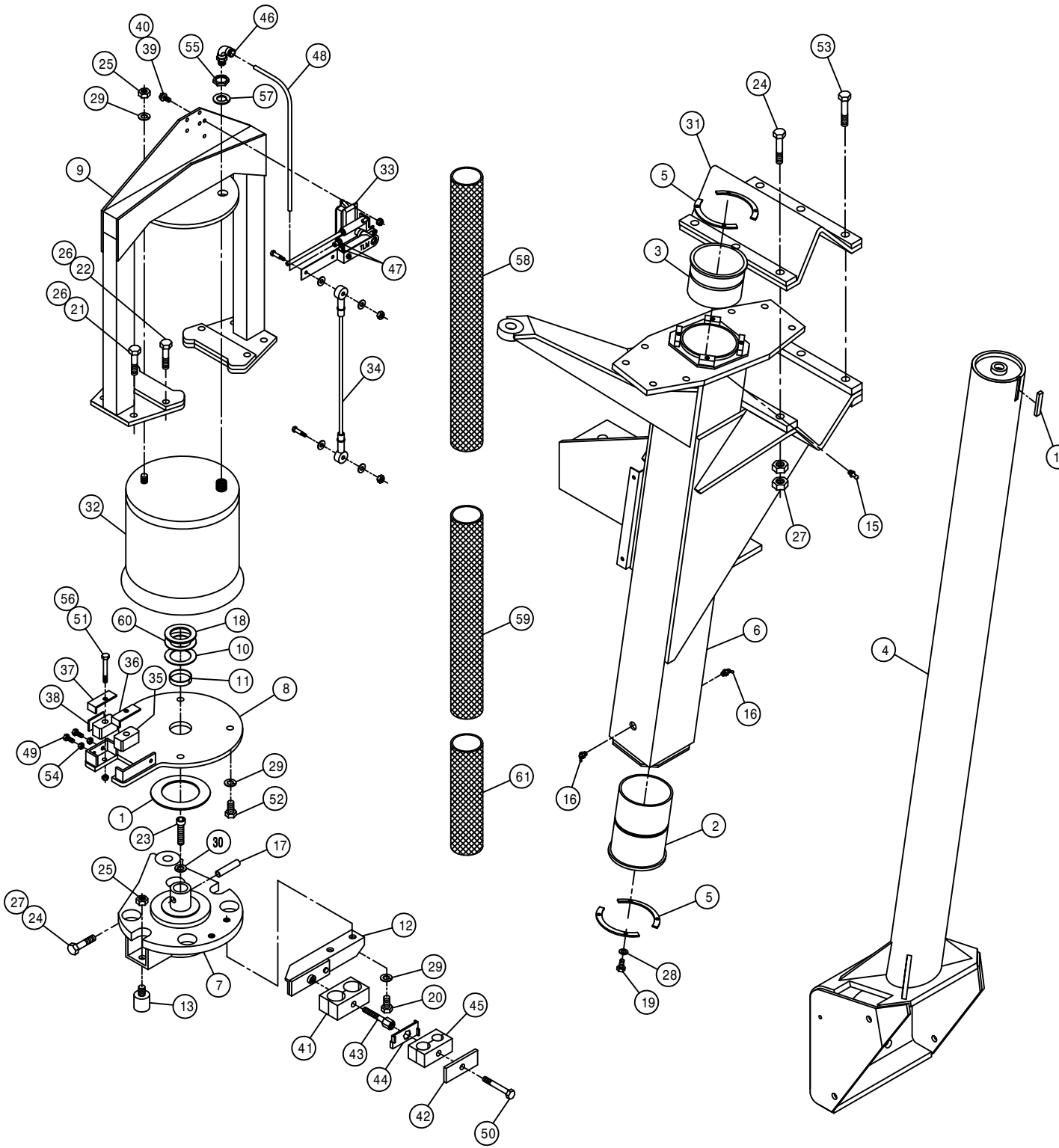

DET.	QTY	PART NO.	DESCRIPTION
1	1	127505	THRUST BEARING, FIBERGLIDE
2	1	358564	FRT LEG LWR NYL SLEEVE 280 89
3	1	358565	FRT LEG UPR NYL SLEEVE 280 89
4	1	359194	RF/LR INNER LEG WLD, 2100 02
5	4	358927	LWR BRG KPR, LEG 98
6	1	358954	RH FRT OUTER LEG WLD, 2100 99
7	1	358971	STEERING ARM WLD,RF/LR 2100 99
8	1	358980	AIR BAG MT WLD, RF/LR 2100 99
9	1	358985	AIR BAG ARCH WLD,RF/LR 2100 99
10	1	358994	LEG WASHER, NYLON 2100 99
11	1	358995	NYLON BEARING,LWR AB MT2100 99
12	1	358996	RH UPPER HOSE MT WELD, 2100 99
13	2	470259	URETHANE BUMPER,1.25D X 1.25L
14	1	470265	KEY, .250 X .375 X 1.88 LG
15	1	471005	1/4 28 X 1/2 GREASE ZERK
16	2	471023	GREASE ZERK 1/4-28 X 45
17	1	473906	SPIRAL PIN, 1/2 X 2 1/2 LG
18	1	483061	1.65 ID X 2.50 OD X .188T WASH
19	8	900064	5/16UNC X 3/4 HEX BOLT
20	2	900263	1/2UNC X 1" HEX BOLT
21	4	900265	1/2UNC X 1 1/2 HEX BOLT
22	4	900267	1/2UNC X 2" HEX BOLT
23	1	900390	5/8UNC X 2 1/2 SOCKET CAP SCR
24	4	900836	5/8UNF X 3 1/4 HEX BOLT GR8
25	3	910008	1/2UNC HEX NUT
26	8	914008	1/2UNC HEX STOVER NUT
27	14	914811	5/8UNF HEX NUT GR8
28	8	920501	5/16 LOCK WASHER
29	7	920504	1/2 LOCK WASHER
30	1	920505	5/8 LOCK WASHER
31	1	358759	LEG MT V-PLT WLD, 284T 94
32	1	358831	AIRIDE SPRING 98
33	1	358832	AIRIDE SPRING CTRL VALVE 98
34	1	358839	AIRIDE CTRL LINK KIT, 2100 99
35	2	358990	NYLON GUIDE, 2100 LEG 99
36	1	358991	INNER KEEPER,NYL GUIDE,2100 99
37	1	358992	OUTER KEEPER,NYL GUIDE,2100 99
38	1	358993	NYLON GUIDE BACK PLATE,2100 99
39	2	470118	1/4UNC X 3/4 FLANGE HEX BOLT
40	2	470121	1/4UNC HEX FLANGE HEX NUT
41	1	470271	HOSE CLAMP BODY,1.181-1.181
42	1	470276	CLAMP COVER PLATE,SNGL, 2.55LG
43	1	470280	STACK BOLT, 5/16UNC X 1 3/4
44	1	470281	STACK BOLT SAFETY LOCK PLATE
45	1	470282	HOSE CLAMP BODY, .53-.78
46	1	711040	1/4MNPT-90-1/4 NYL TUBE LBO
47	2	711036	1/8MNPT-1/4 NYL TUBE FTG
48	1	601413	HOSE, 1/4 X 8 AIR
49	2	900065	5/16UNC X 1" HEX BOLT
50	1	900068	5/16UNC X 1 3/4 HEX BOLT
51	2	900069	5/16UNC X 2" HEX BOLT
52	4	900264	1/2UNC X 1 1/4 HEX BOLT
53	3	900837	5/8UNF X 3 1/2 HEX BOLT GR8
54	2	910002	5/16UNC HEX NUT
55	1	910013	3/4UNF HEX NUT
56	2	914002	5/16UNC HEX STOVER NUT
57	1	920506	3/4 LOCK WASHER
58	1	342637	NYL HOSE SLEEVE,2.96ID X 54.00
59	1	342335	NYL HOSE SLEEVE,2.64ID X 36.00
60	1	483063	1.65 ID X 2.50 OD X .074T WASH
61	1	342654	NYL HOSE SLEEVE,3.66ID X 24.00

RIGHT FRONT LEG ASSEMBLY

DET.	QTY	PART NO.	DESCRIPTION
1	1	359185	WHL MTR SHLD, XP/2100 2002
2	1	358926	FRT LEG HYD TUBE BRKT, 2100 98
3	2	900263	1/2UNC X 1" HEX BOLT
4	1	470272	TUBE CLAMP BODY, .375-.500
5	1	470275	TUBE CLAMP BODY, 1.000-1.000
6	1	470277	CLAMP WELD PLATE, SNGL, 2.15LG
7	1	470278	CLAMP WELD PLATE, SNGL, 2.75LG
8	1	471023	GREASE ZERK 1/4-28 X 45
9	1	610013	ZERK BOLT, 5/8 X 1 1/4 TORQ HUB
10	1	610800	TORQ HUB, 18.78:1 W/O BRAKE
11	1	610637	SUND HYD MOTOR, M46-4019
12	1	615708	LWR HYD TUBE ASSY, LEG 2100 98
13	1	615709	UPR HYD TUBE ASSY, LEG 2100 98
14	1	615710	RF/LR HYD DRN TUBE ASSY 2100 98
15	1	615712	RF/LR HYD CTRL TUBE ASSY 210098
16	1	618119	9/16MJIC-90-9/16MOR LBO
17	2	618178	1 5/16MJIC-90-1 5/16MOR LBO
18	1	618474	3/4MJIC-90-1 1/16MOR LBO
19	1	662256	STALK GUIDE WLD, 2100 2000
20	1	870045	O-RING 4 1/8 OD X 4 ID
21	1	900068	5/16UNC X 1 3/4 HEX BOLT
22	1	900070	5/16UNC X 2 1/2 BOLT
23	3	920004	1/2 SAE FLAT WASHER
24	3	900264	1/2UNC X 1 1/4 HEX BOLT
25	1	900265	1/2UNC X 1 1/2 HEX BOLT
26	2	900266P	1/2UNC X 1 3/4 HEX BOLT
27	5	900332P	5/8UNC X 1 1/4 HEX BOLT
28	2	914002	5/16UNC HEX STOVER NUT
29	6	914008	1/2UNC HEX STOVER NUT
30	2	920504P	1/2 LOCK WASHER
31	6	920505P	5/8 LOCK WASHER
32	2	618577	1 5/16MJIC UNION
33	1	618314	3/4MJIC UNION
34	1	619010	9/16MJIC UNION
35	9	470140	5/8UNF HEX SMTH FLANGE NUT PLT
36	1	359014	FRT HYD TUBE MTG PLT, 2100 00

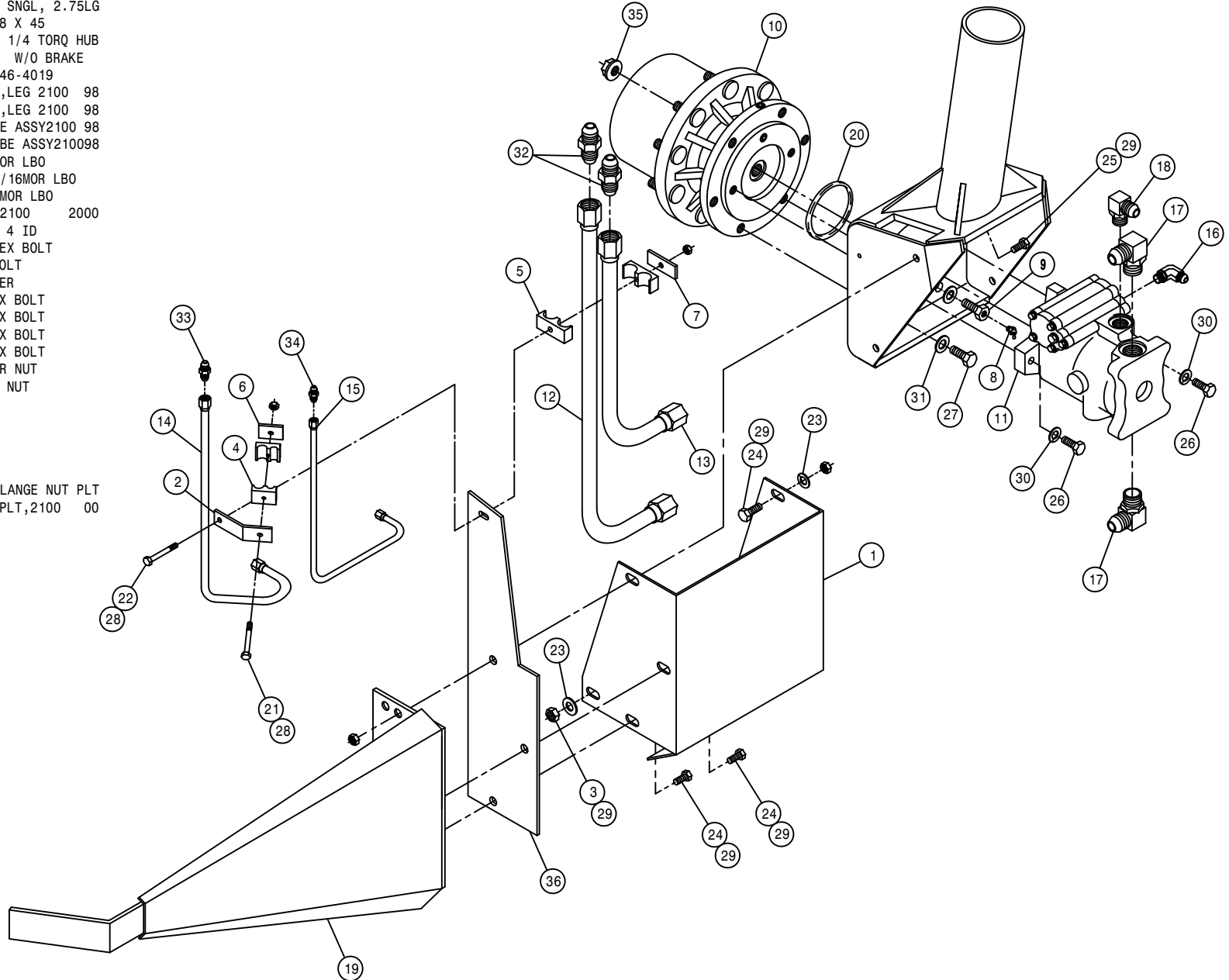

LEFT FRONT LEG ASSEMBLY

DET. QTY PART NO. DESCRIPTION

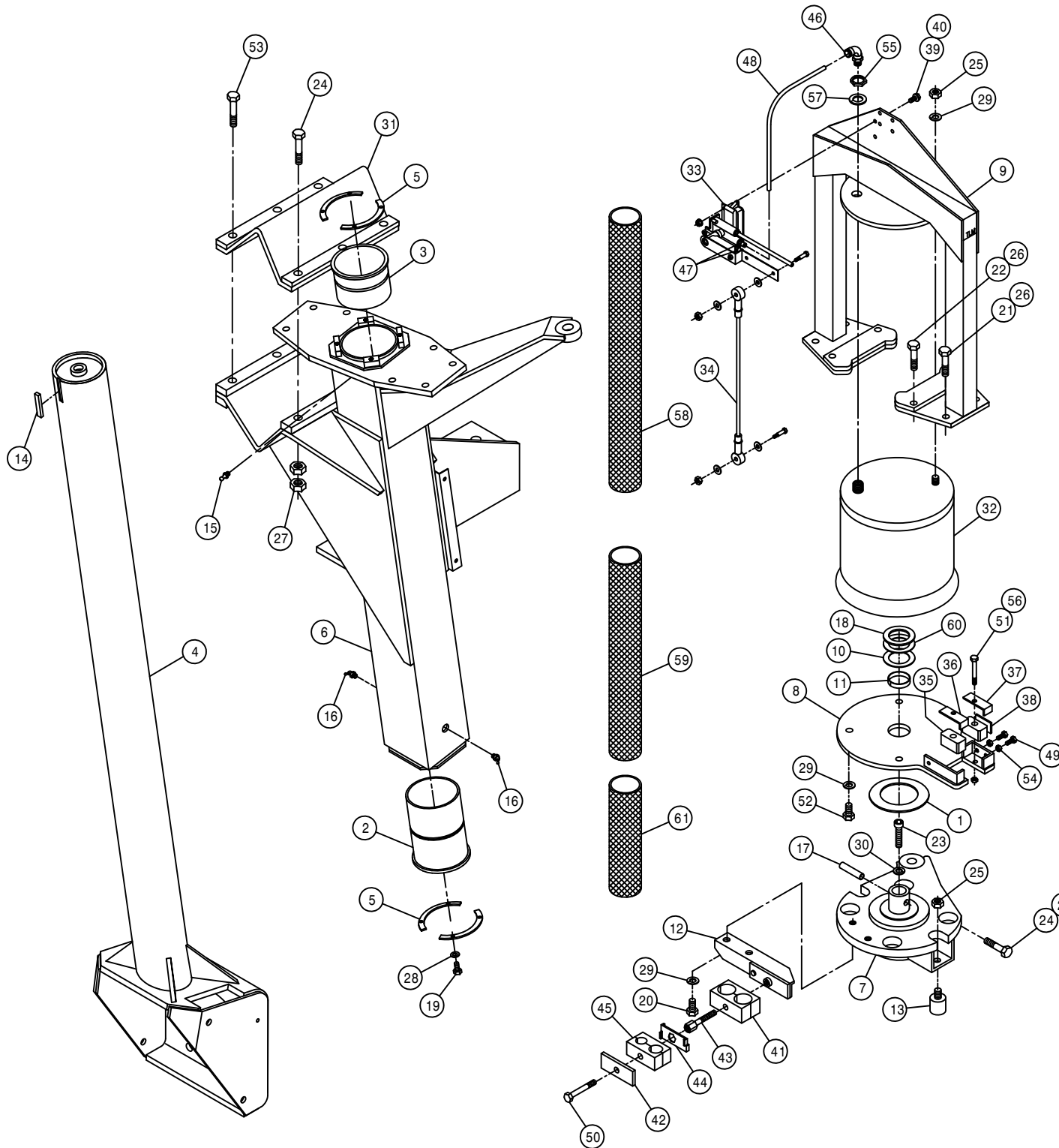

DET.	QTY	PART NO.	DESCRIPTION
1	1	127505	THRUST BEARING, FIBERGLIDE
2	1	358564	FRT LEG LWR NYL SLEEVE 280 89
3	1	358565	FRT LEG UPR NYL SLEEVE 280 89
4	1	359195	LF/RR INNER LEG WLD, 2100 02
5	4	358927	LWR BRG KPR, LEG
6	1	358955	LH FRT OUTER LEG WLD, 2100 99
7	1	358972	STEERING ARM WLD, LF/RR 2100 99
8	1	358981	AIR BAG MT WLD, LF/RR 2100 99
9	1	358986	AIR BAG ARCH WLD, LF/RR 2100 99
10	1	358994	LEG WASHER, NYLON 2100 99
11	1	358995	NYLON BEARING, LWR AB MT2100 99
12	1	358997	LH UPPER HOSE MT WELD, 2100 99
13	2	470259	URETHANE BUMPER, 1.25D X 1.25L
14	1	470265	KEY, .250 X .375 X 1.88 LG
15	1	471005	1/4 28 X 1/2 GREASE ZERK
16	2	471023	GREASE ZERK 1/4-28 X 45
17	1	473906	SPIRAL PIN, 1/2 X 2 1/2 LG
18	1	483061	1.65 ID X 2.50 OD X .188T WASH
19	8	900064	5/16UNC X 3/4 HEX BOLT
20	2	900263	1/2UNC X 1" HEX BOLT
21	4	900265	1/2UNC X 1 1/2 HEX BOLT
22	4	900267	1/2UNC X 2" HEX BOLT
23	1	900390	5/8UNC X 2 1/2 SOCKET CAP SCR
24	4	900836	5/8UNF X 3 1/4 HEX BOLT GR8
25	3	910008	1/2UNC HEX NUT
26	8	914008	1/2UNC HEX STOVER NUT
27	14	914811	5/8UNF HEX NUT GR8
28	8	920501	5/16 LOCK WASHER
29	7	920504	1/2 LOCK WASHER
30	1	920505	5/8 LOCK WASHER
31	1	358759	LEG MT V-PLT WLD, 284T 94
32	1	358831	AIRIDE SPRING 98
33	1	358832	AIRIDE SPRING CTRL VALVE 98
34	1	358839	AIRIDE CTRL LINK KIT, 2100 99
35	2	358990	NYLON GUIDE, 2100 LEG 99
36	1	358991	INNER KEEPER, NYL GUIDE, 2100 99
37	1	358992	OUTER KEEPER, NYL GUIDE, 2100 99
38	1	358993	NYLON GUIDE BACK PLATE, 2100 99
39	2	470118	1/4UNC X 3/4 FLANGE HEX BOLT
40	2	470121	1/4UNC HEX FLANGE LOCK NUT
41	1	470271	HOSE CLAMP BODY, 1.181-1.181
42	1	470276	CLAMP COVER PLATE, SNGL, 2.55LG
43	1	470280	STACK BOLT, 5/16UNC X 1 3/4
44	1	470281	STACK BOLT SAFETY LOCK PLATE
45	1	470282	HOSE CLAMP BODY, .53-.78
46	1	711040	1/4MNPT-90-1/4 NYL TUBE LBO
47	2	711036	1/8MNPT-1/4 NYL TUBE FTG
48	1	601413	HOSE, 1/4 X 8 AIR
49	2	900065	5/16UNC X 1" HEX BOLT
50	1	900068	5/16UNC X 1 3/4 HEX BOLT
51	2	900069	5/16UNC X 2" HEX BOLT
52	4	900264	1/2UNC X 1 1/4 HEX BOLT
53	3	900837	5/8UNF X 3 1/2 HEX BOLT GR8
54	2	910002	5/16UNC HEX NUT
55	1	910013	3/4UNF HEX NUT
56	2	914002	5/16UNC HEX STOVER NUT
57	1	920506	3/4 LOCK WASHER
58	1	342637	NYL HOSE SLEEVE, 2.96ID X 54.00
59	1	342335	NYL HOSE SLEEVE, 2.64ID X 36.00
60	1	483063	1.65 ID X 2.50 OD X .074T WASH
61	1	342654	NYL HOSE SLEEVE, 3.66ID X 24.00

LEFT FRONT LEG ASSEMBLY

DET. QTY PART NO. DESCRIPTION

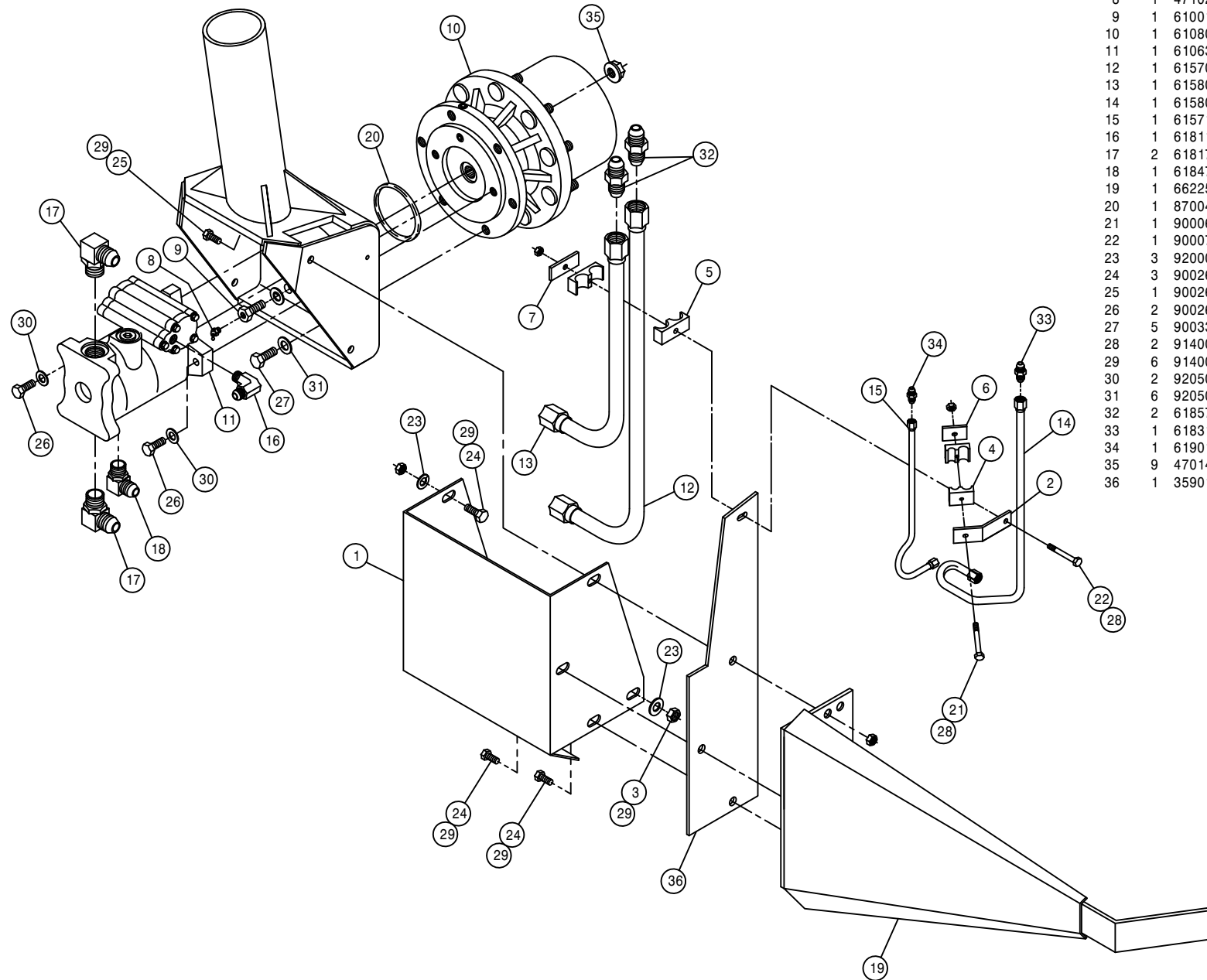

DET.	QTY	PART NO.	DESCRIPTION
1	1	359185	WHL MTR SHLD, XP/2100 2002
2	1	358926	FRT LEG HYD TUBE BRKT, 2100 98
3	2	900263	1/2UNC X 1" HEX BOLT
4	1	470272	TUBE CLAMP BODY, .375-.500
5	1	470275	TUBE CLAMP BODY, 1.000-1.000
6	1	470277	CLAMP WELD PLATE, SNGL, 2.15LG
7	1	470278	CLAMP WELD PLATE, SNGL, 2.75LG
8	1	471023	GREASE ZERK 1/4-28 X 45
9	1	610013	ZERK BOLT, 5/8 X 1 1/4 TORQ HUB
10	1	610800	TORQ HUB, 18.78:1 W/O BRAKE
11	1	610637	SUND HYD MOTOR, M46-4019
12	1	615708	LWR HYD TUBE ASSY, LEG 2100 98
13	1	615808	UPR HYD TUBE ASSY, LEG 2100 03
14	1	615809	LF/RR HYD DRN TUBE ASSY2100 03
15	1	615713	LF/RR HYD CTRL TUBE ASSY210098
16	1	618119	9/16MJIC-90-9/16MOR LBO
17	2	618178	1 5/16MJIC-90-1 5/16MOR LBO
18	1	618474	3/4MJIC-90-1 1/16MOR LBO
19	1	662256	STALK GUIDE WLD, 2100 2000
20	1	870045	O-RING 4 1/8 OD X 4 ID
21	1	900068	5/16UNC X 1 3/4 HEX BOLT
22	1	900070	5/16UNC X 2 1/2 BOLT
23	3	920004	1/2 SAE FLAT WASHER
24	3	900264	1/2UNC X 1 1/4 HEX BOLT
25	1	900265	1/2UNC X 1 1/2 HEX BOLT
26	2	900266P	1/2UNC X 1 3/4 HEX BOLT
27	5	900332P	5/8UNC X 1 1/4 HEX BOLT
28	2	914002	5/16UNC HEX STOVER NUT
29	6	914008	1/2UNC HEX STOVER NUT
30	2	920504P	1/2 LOCK WASHER
31	6	920505P	5/8 LOCK WASHER
32	2	618577	1 5/16MJIC UNION
33	1	618314	3/4MJIC UNION
34	1	619010	9/16MJIC UNION
35	9	470140	5/8UNF HEX SMTH FLANGE NUT PLT
36	1	359014	FRT HYD TUBE MTG PLT, 2100 00

RIGHT REAR LEG ASSEMBLY

DET. QTY PART NO. DESCRIPTION

DET.	QTY	PART NO.	DESCRIPTION
1	1	483062	3.00 ID X 4.62 OD X .125T WASH
2	1	358564	FRT LEG LWR NYL SLEEVE 280 89
3	1	358565	FRT LEG UPR NYL SLEEVE 280 89
4	1	359195	LF/RR INNER LEG WLD, 2100 02
5	4	358927	LWR BRG KPR, LEG 98
6	1	358956	RH REAR OUTER LEG WLD,2100 99
7	1	358972	STEERING ARM WLD,LF/RR 2100 99
8	1	358981	AIR BAG MT WLD, LF/RR 2100 99
9	1	358986	AIR BAG ARCH WLD,LF/RR 2100 99
10	1	358994	LEG WASHER, NYLON 2100 99
11	1	358995	NYLON BEARING,LWR AB MT2100 99
12	2	900069	5/16UNC X 2" HEX BOLT
13	2	470259	URETHANE BUMPER,1.25D X 1.25L
14	1	470265	KEY, .250 X .375 X 1.88 LG
15	1	471005	1/4 28 X 1/2 GREASE ZERK
16	2	471023	GREASE ZERK 1/4-28 X 45
17	1	473906	SPIRAL PIN, 1/2 X 2 1/2 LG
18	1	483061	1.65 ID X 2.50 OD X .188T WASH
19	8	900064	5/16UNC X 3/4 HEX BOLT
20	4	900264	1/2UNC X 1 1/4 HEX BOLT
21	4	900265	1/2UNC X 1 1/2 HEX BOLT
22	4	900267	1/2UNC X 2" HEX BOLT
23	1	900390	5/8UNC X 2 1/2 SOCKET CAP SCR
24	4	900836	5/8UNF X 3 1/4 HEX BOLT GR8
25	3	910008	1/2UNC HEX NUT
26	8	914008	1/2UNC HEX STOVER NUT
27	14	914811	5/8UNF HEX NUT GR8
28	8	920501	5/16 LOCK WASHER
29	5	920504	1/2 LOCK WASHER
30	1	920505	5/8 LOCK WASHER
31	1	358759	LEG MT V-PLT WLD, 284T 94
32	1	358831	AIRIDE SPRING 98
33	1	358832	AIRIDE SPRING CTRL VALVE 98
34	1	358839	AIRRIDE CTRL LINK KIT, 2100 99
35	2	358990	NYLON GUIDE, 2100 LEG 99
36	1	358991	INNER KEEPER,NYL GUIDE,2100 99
37	1	358992	OUTER KEEPER,NYL GUIDE,2100 99
38	1	358993	NYLON GUIDE BACK PLATE,2100 99
39	2	470118	1/4UNC X 3/4 FLANGE HEX BOLT
40	2	470121	1/4UNC HEX FLANGE LOCK NUT
41	3	900837	5/8UNF X 3 1/2 HEX BOLT GR8
42	2	910002	5/16UNC HEX NUT
43	1	910013	3/4UNF HEX NUT
44	2	914002	5/16UNC HEX STOVER NUT
45	1	920506	3/4 LOCK WASHER
46	1	711040	1/4MNPT-90-1/4 NYL TUBE LBO
47	2	711036	1/8MNPT-1/4 NYL TUBE FTG
48	1	601413	HOSE, 1/4 X 8 AIR
49	2	900065	5/16UNC X 1" HEX BOLT
50	1	342828	NYL HOSE SLEEVE,3.34ID X 65.00
51	1	483063	1.65 ID X 2.50 OD X .074T WASH
52	1	342654	NYL HOSE SLEEVE,3.66ID X 24.00

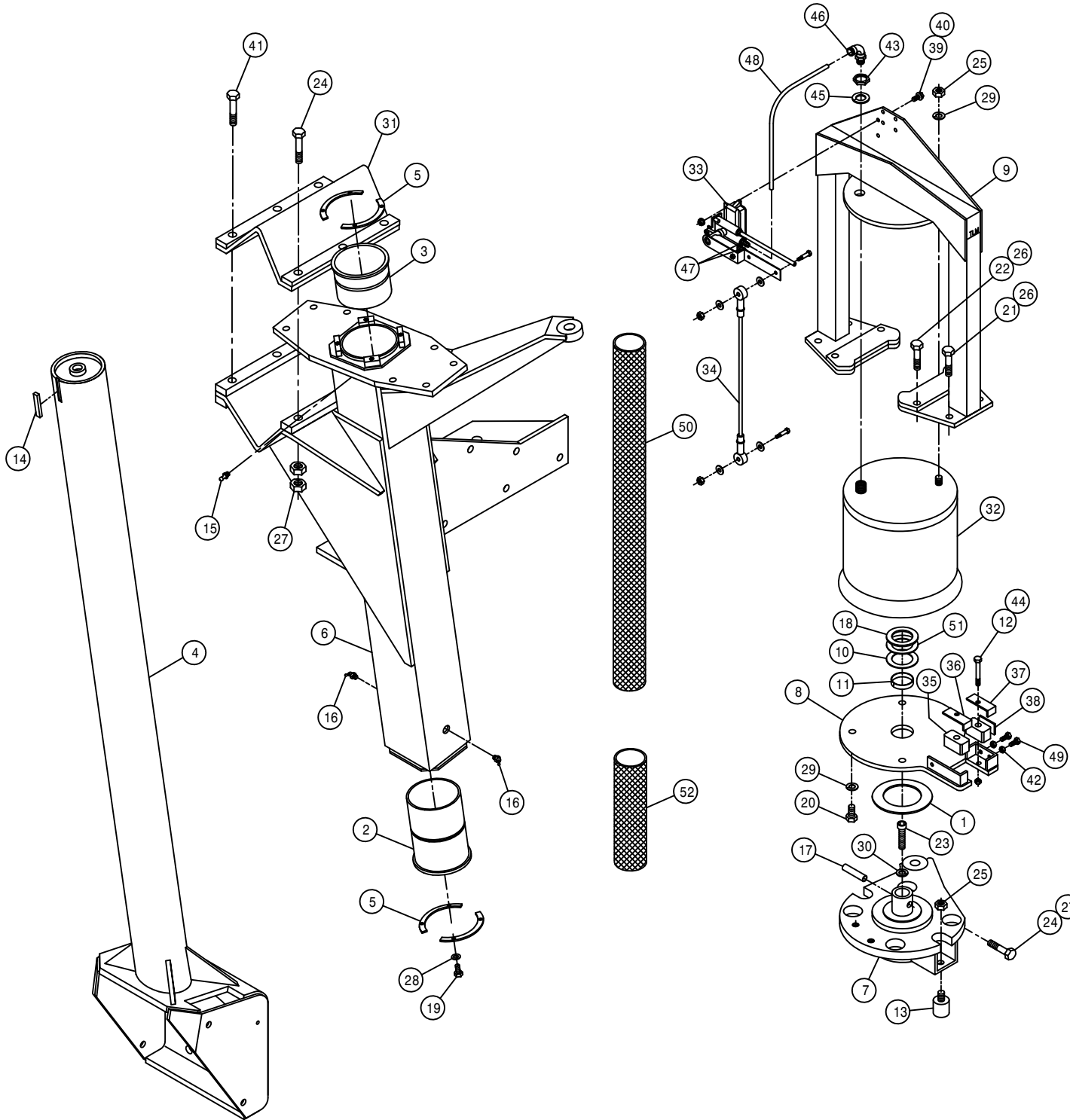

RIGHT REAR LEG ASSEMBLY

DET. QTY PART NO. DESCRIPTION

1	1	359185	WHL MTR SHLD, XP/2100	2002
2	1	358934	REAR LEG HYD TUBE BRKT,2100 98	
3	1	618634	9/16MJIC-45-9/16FJIC SWIV LBO	
4	1	470273	TUBE CLAMP BODY, .375-.375-.500	
5	1	470275	TUBE CLAMP BODY,1.000-1.000	
6	1	470277	CLAMP WELD PLATE, SNGL, 2.15LG	
7	1	470278	CLAMP WELD PLATE, SNGL, 2.75LG	
8	1	471023	GREASE ZERK 1/4-28 X 45	
9	1	610013	ZERK BOLT,5/8 X 1 1/4 TORQ HUB	
10	1	610803	TORQ HUB, 24.40:1 W/BRAKE	
11	1	608000	SAUER HYD MOTOR, M46-4024	
12	1	615708	LWR HYD TUBE ASSY,LEG 2100 98	
13	1	615808	UPR HYD TUBE ASSY,LEG 2100 03	
14	1	615809	LF/RR HYD DRN TUBE ASSY2100 03	
15	1	615713	LF/RR HYD CTRL TUBE ASSY210098	
16	1	618119	9/16MJIC-90-9/16MOR LBO	
17	2	618178	1 5/16MJIC-90-1 5/16MOR LBO	
18	1	618474	3/4MJIC-90-1 1/16MOR LBO	
19	1	662256	STALK GUIDE WLD, 2100	2000
20	1	870045	O-RING 4 1/8 OD X 4 ID	
21	1	900068	5/16UNC X 1 3/4 HEX BOLT	
22	1	900070	5/16UNC X 2 1/2 BOLT	
23	2	920004	1/2 SAE FLAT WASHER	
24	6	900264	1/2UNC X 1 1/4 HEX BOLT	
25	2	900263	1/2UNC X 1" HEX BOLT	
26	2	900266P	1/2UNC X 1 3/4 HEX BOLT	
27	5	900332P	5/8UNC X 1 1/4 HEX BOLT	
28	2	914002	5/16UNC HEX STOVER NUT	
29	8	914008	1/2UNC HEX STOVER NUT	
30	2	920504P	1/2 LOCK WASHER	
31	6	920505P	5/8 LOCK WASHER	
32	2	618577	1 5/16MJIC UNION	
33	1	618314	3/4MJIC UNION	
34	2	619010	9/16MJIC UNION	
35	9	470140	5/8UNF HEX SMTH FLANGE NUT PLT	
36	1	359014	FRT HYD TUBE MTG PLT,2100 00	
37	1	615815	RH HYD BRAKE TUBE ASSY,2101 04	
38	1	618304	9/16MJIC-7/16MOR ADPTR	

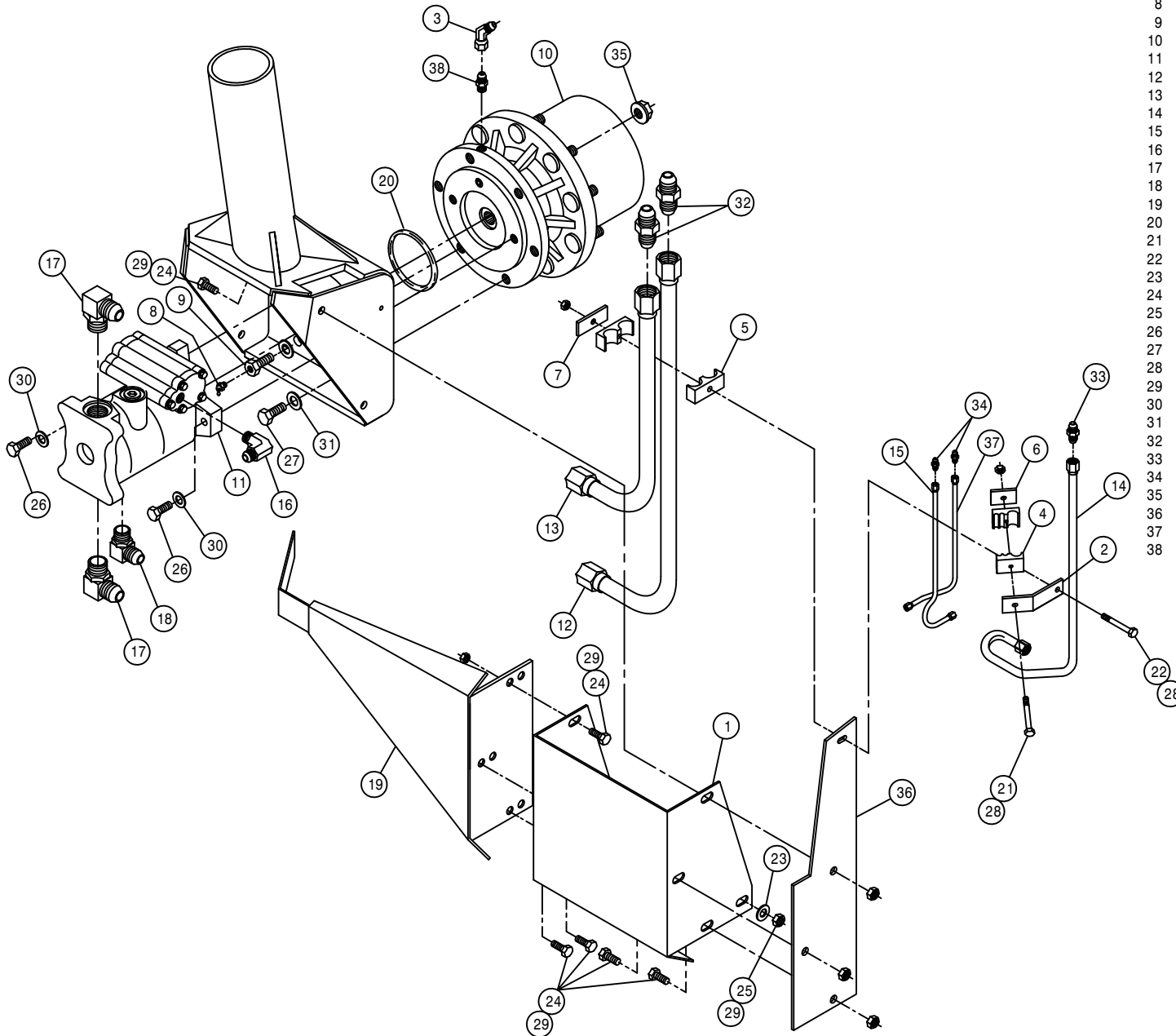

LEFT REAR LEG ASSEMBLY

DET. QTY PART NO. DESCRIPTION

DET.	QTY	PART NO.	DESCRIPTION
1	1	483062	3.00 ID X 4.62 OD X .125T WASH
2	1	358564	FRT LEG LWR NYL SLEEVE 280 89
3	1	358565	FRT LEG UPR NYL SLEEVE 280 89
4	1	359194	RF/LR INNER LEG WLD, 2100 02
5	4	358927	LWR BRG KPR, LEG 98
6	1	358957	LH REAR OUTER LEG WLD,2100 99
7	1	358971	STEERING ARM WLD,RF/LR 2100 99
8	1	358980	AIR BAG MT WLD, RF/LR 2100 99
9	1	358985	AIR BAG ARCH WLD,RF/LR 2100 99
10	1	358994	LEG WASHER, NYLON 2100 99
11	1	358995	NYLON BEARING,LWR AB MT2100 99
12	2	900069	5/16UNC X 2" HEX BOLT
13	2	470259	URETHANE BUMPER,1.25D X 1.25L
14	1	470265	KEY, .250 X .375 X 1.88 LG
15	1	471005	1/4 28 X 1/2 GREASE ZERK
16	2	471023	GREASE ZERK 1/4-28 X 45
17	1	473906	SPIRAL PIN, 1/2 X 2 1/2 LG
18	1	483061	1.65 ID X 2.50 OD X .188T WASH
19	8	900064	5/16UNC X 3/4 HEX BOLT
20	4	900264	1/2UNC X 1 1/4 HEX BOLT
21	4	900265	1/2UNC X 1 1/2 HEX BOLT
22	4	900267	1/2UNC X 2" HEX BOLT
23	1	900390	5/8UNC X 2 1/2 SOCKET CAP SCR
24	4	900836	5/8UNF X 3 1/4 HEX BOLT GR8
25	3	910008	1/2UNC HEX NUT
26	8	914008	1/2UNC HEX STOVER NUT
27	14	914811	5/8UNF HEX NUT GR8
28	8	920501	5/16 LOCK WASHER
29	5	920504	1/2 LOCK WASHER
30	1	920505	5/8 LOCK WASHER
31	1	358759	LEG MT V-PLT WLD, 284T 94
32	1	358831	AIRIDE SPRING 98
33	1	358832	AIRIDE SPRING CTRL VALVE 98
34	1	358839	AIRIDE CTRL LINK KIT, 2100 99
35	2	358990	NYLON GUIDE, 2100 LEG 99
36	1	358991	INNER KEEPER,NYL GUIDE,2100 99
37	1	358992	OUTER KEEPER,NYL GUIDE,2100 99
38	1	358993	NYLON GUIDE BACK PLATE,2100 99
39	2	470118	1/4UNC X 3/4 FLANGE HEX BOLT
40	2	470121	1/4UNC HEX FLANGE LOCK NUT
41	3	900837	5/8UNF X 3 1/2 HEX BOLT GR8
42	2	910002	5/16UNC HEX NUT
43	1	910013	3/4UNF HEX NUT
44	2	914002	5/16UNC HEX STOVER NUT
45	1	920506	3/4 LOCK WASHER
46	1	711040	1/4MNPT-90-1/4 NYL TUBE LBO
47	2	711036	1/8MNPT-1/4 NYL TUBE FTG
48	1	601413	HOSE, 1/4 X 8 AIR
49	2	900065	5/16UNC X 1" HEX BOLT
50	1	342828	NYL HOSE SLEEVE,3.34ID X 65.00
51	1	483063	1.65 ID X 2.50 OD X .074T WASH
52	1	342654	NYL HOSE SLEEVE,3.66ID X 24.00

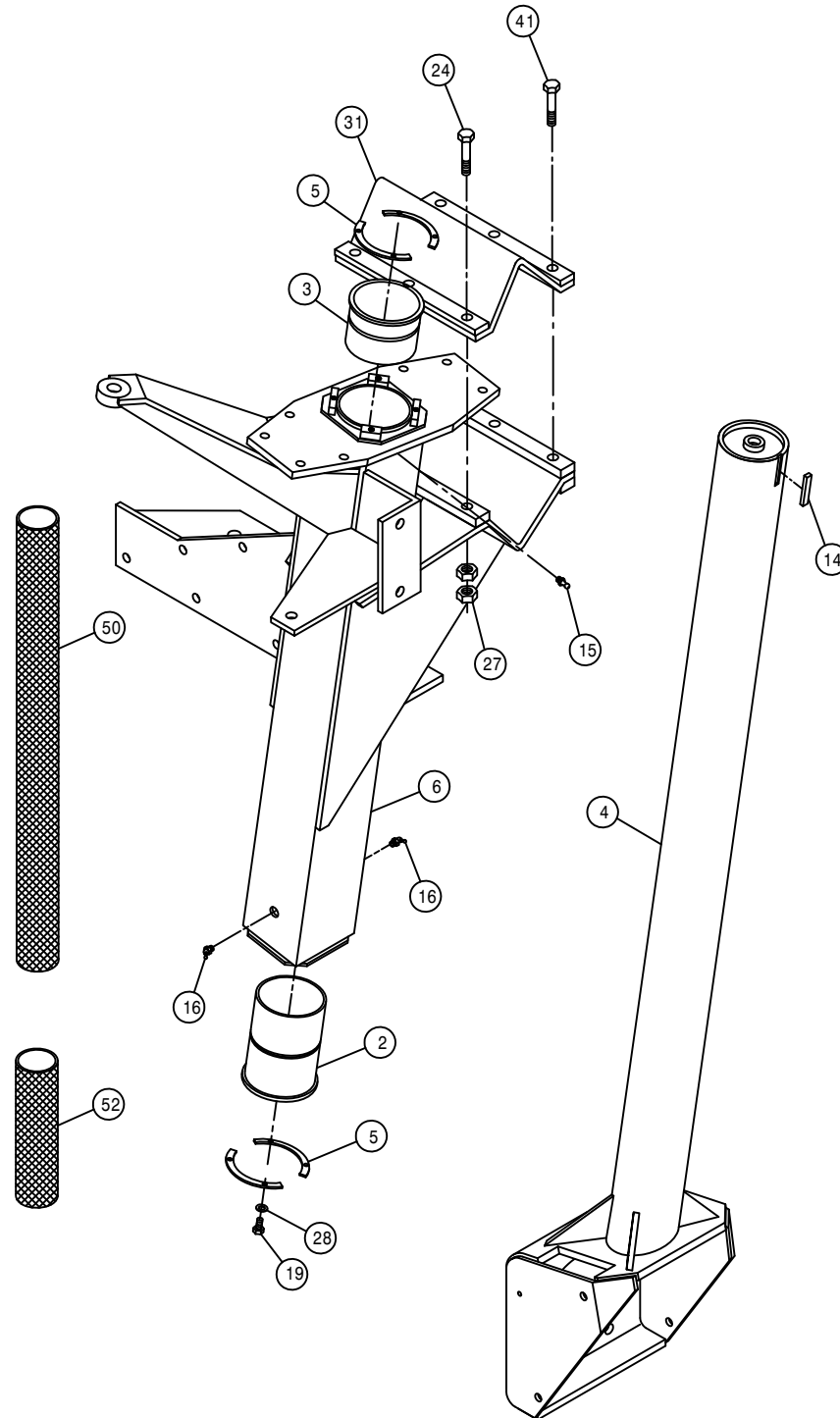
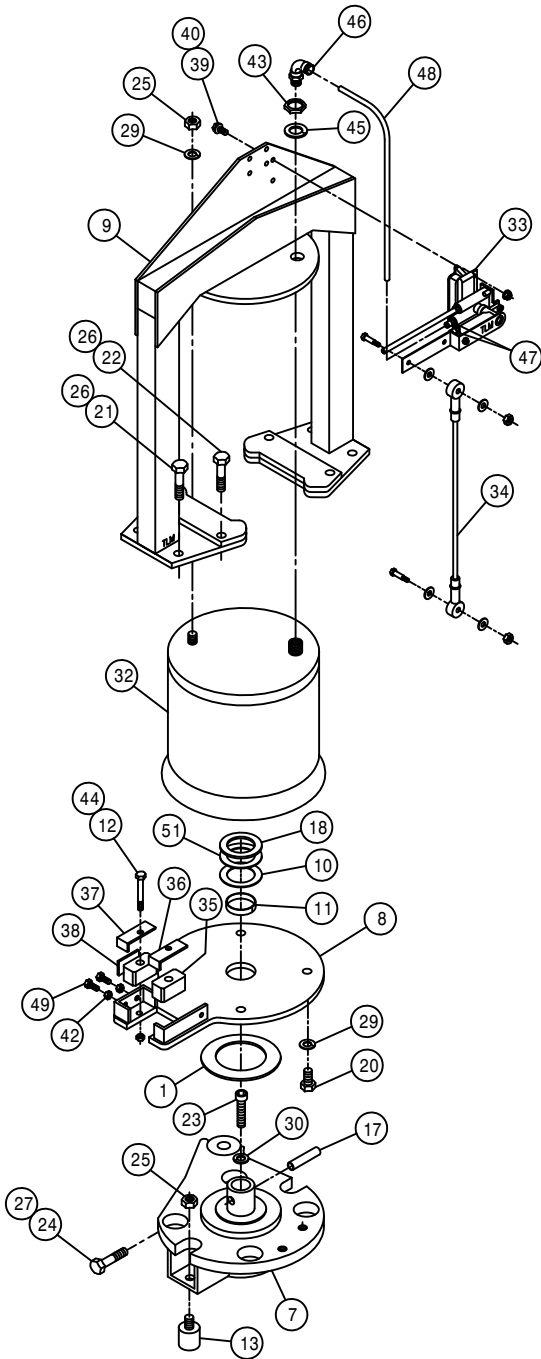

LEFT REAR LEG ASSEMBLY

DET. QTY PART NO. DESCRIPTION

1	1	359185	WHL MTR SHLD, XP/2100	2002
2	1	358934	REAR LEG HYD TUBE BRKT,2100	98
3	1	618634	9/16MJIC-45-9/16FJIC SWIV LBO	
4	1	470273	TUBE CLAMP BODY, .375-.375-.500	
5	1	470275	TUBE CLAMP BODY,1.000-1.000	
6	1	470277	CLAMP WELD PLATE, SNGL, 2.15LG	
7	1	470278	CLAMP WELD PLATE, SNGL, 2.75LG	
8	1	471023	GREASE ZERK 1/4-28 X 45	
9	1	610013	ZERK BOLT,5/8 X 1 1/4 TORQ HUB	
10	1	610803	TORQ HUB, 24.40:1 W/BRAKE	
11	1	608003	SAUER HYD MOTOR,M46-4194 W/SEN	
12	1	615708	LWR HYD TUBE ASSY,LEG 2100	98
13	1	615709	UPR HYD TUBE ASSY,LEG 2100	98
14	1	615710	RF/LR HYD DRN TUBE ASSY2100	98
15	1	615712	RF/LR HYD CTRL TUBE ASSY210098	
16	1	618119	9/16MJIC-90-9/16MOR LBO	
17	2	618178	1 5/16MJIC-90-1 5/16MOR LBO	
18	1	618474	3/4MJIC-90-1 1/16MOR LBO	
19	1	662256	STALK GUIDE WLD, 2100	2000
20	1	870045	O-RING 4 1/8 OD X 4 ID	
21	1	900068	5/16UNC X 1 3/4 HEX BOLT	
22	1	900070	5/16UNC X 2 1/2 BOLT	
23	2	920004	1/2 SAE FLAT WASHER	
24	6	900264	1/2UNC X 1 1/4 HEX BOLT	
25	2	900263	1/2UNC X 1" HEX BOLT	
26	2	900266P	1/2UNC X 1 3/4 HEX BOLT	
27	5	900332P	5/8UNC X 1 1/4 HEX BOLT	
28	2	914002	5/16UNC HEX STOVER NUT	
29	8	914008	1/2UNC HEX STOVER NUT	
30	2	920504P	1/2 LOCK WASHER	
31	6	920505P	5/8 LOCK WASHER	
32	2	618577	1 5/16MJIC UNION	
33	1	618314	3/4MJIC UNION	
34	2	619010	9/16MJIC UNION	
35	9	470140	5/8UNF HEX SMTH FLANGE NUT PLT	
36	1	359014	FRT HYD TUBE MTG PLT,2100	00
37	1	615814	LH HYD BRAKE TUBE ASSY,2101	04
38	1	618304	9/16MJIC-7/16MOR ADPTR	
39	1	610625	SENSOR,WHL MOTOR 610621/610671	

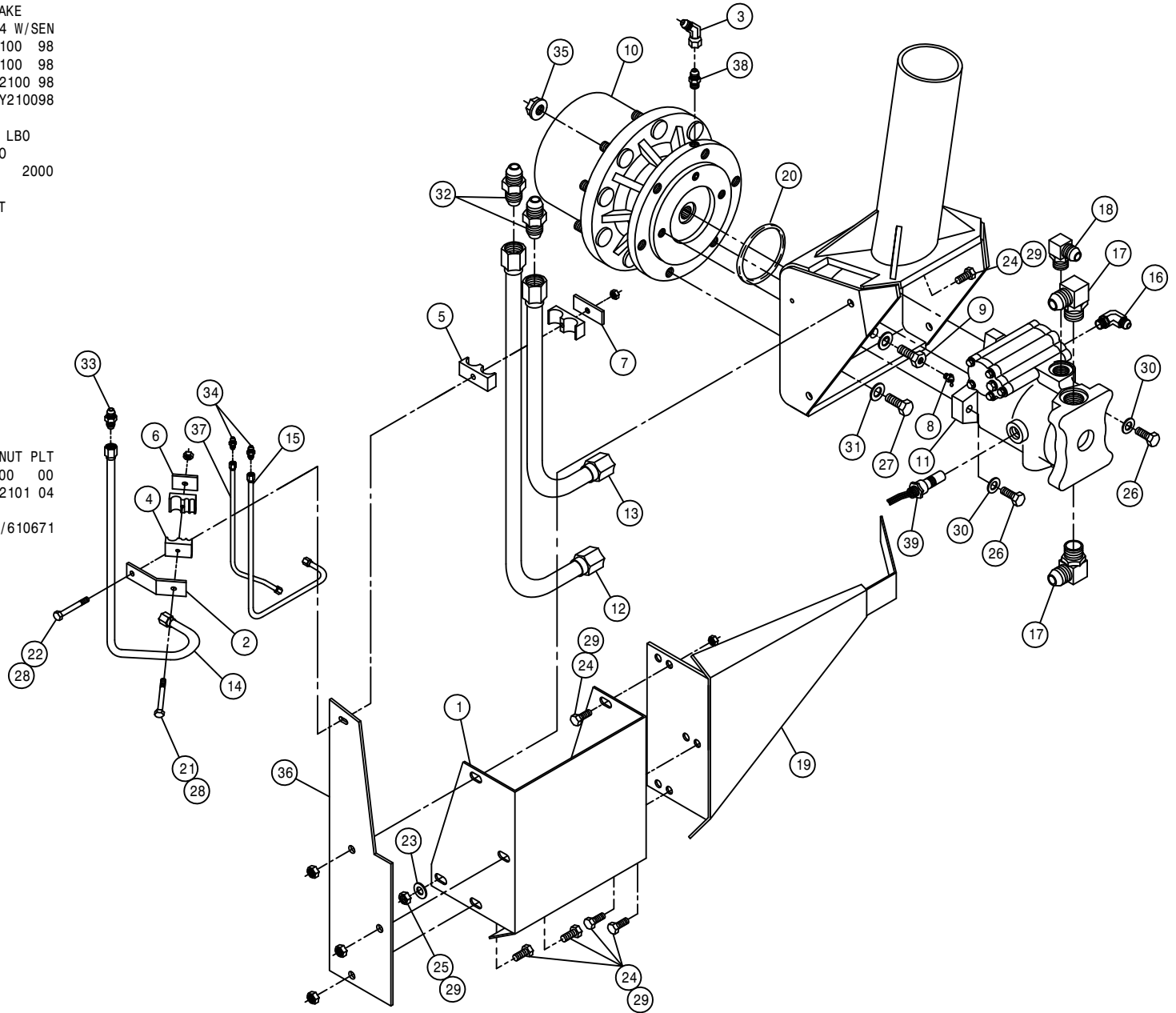

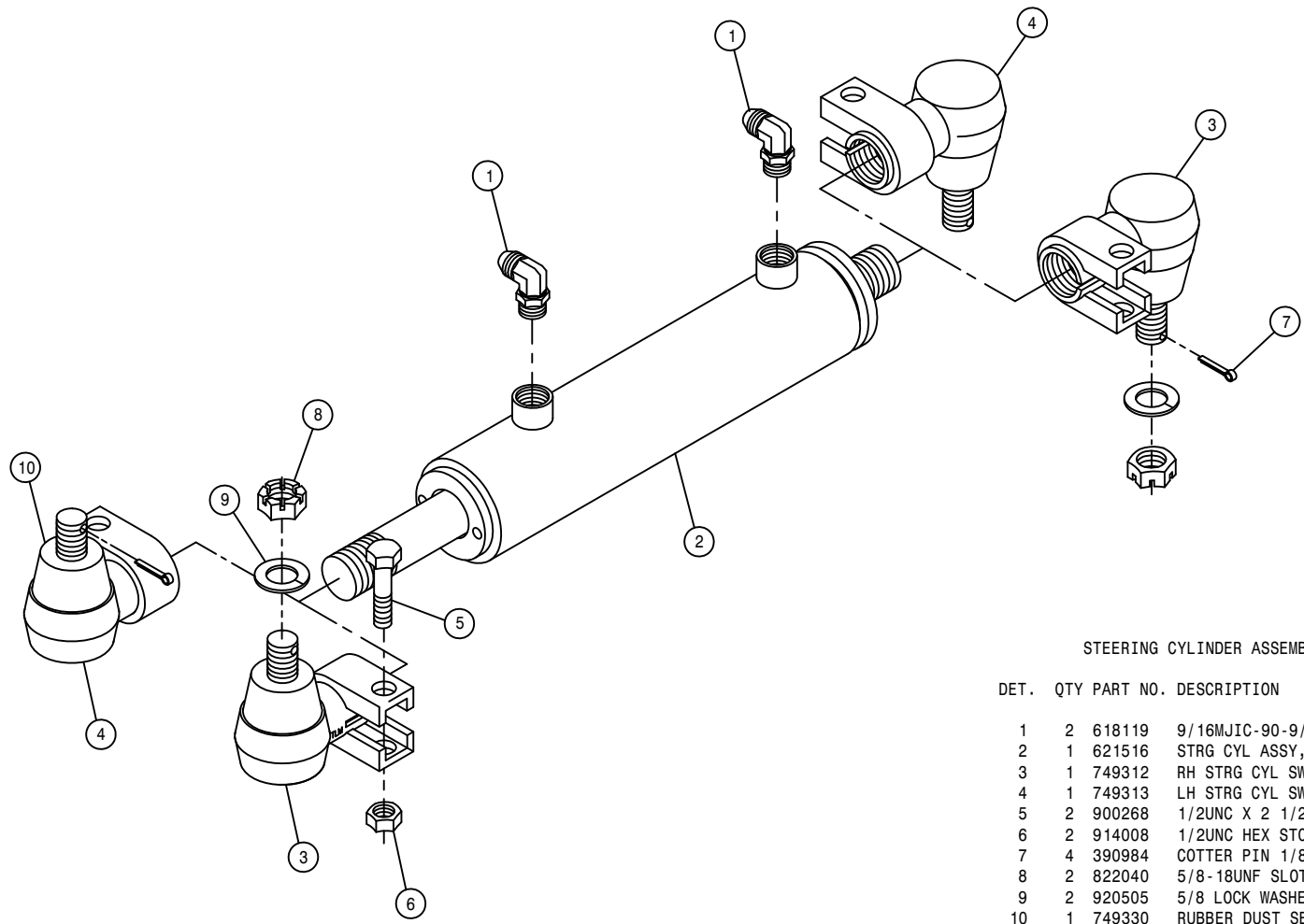

STEERING CYLINDER ASSEMBLY

DET.	QTY	PART NO.	DESCRIPTION
1	2	618119	9/16MJIC-90-9/16MOR LBO
2	1	621516	STRG CYL ASSY, 2100
3	1	749312	RH STRG CYL SWIV ASSY
4	1	749313	LH STRG CYL SWIV ASSY
5	2	900268	1/2UNC X 2 1/2 HEX BOLT
6	2	914008	1/2UNC HEX STOVER NUT
7	4	390984	COTTER PIN 1/8 X 1 1/4
8	2	822040	5/8-18UNF SLOTTED HEX NUT
9	2	920505	5/8 LOCK WASHER
10	1	749330	RUBBER DUST SEAL, (749312/313)
NS	1	621517	REPAIR KIT, HYD CYL 621516

NOTE: 1. 621205 - RH STEERING CYLINDER ASSEMBLY W/CYL SWIV DET.3
 2. 621206 - LH STEERING CYLINDER ASSEMBLY W/CYL SWIV DET.4
 3. 621516 - STEERING CYLINDER ASSEMBLY W/O CYL SWIV

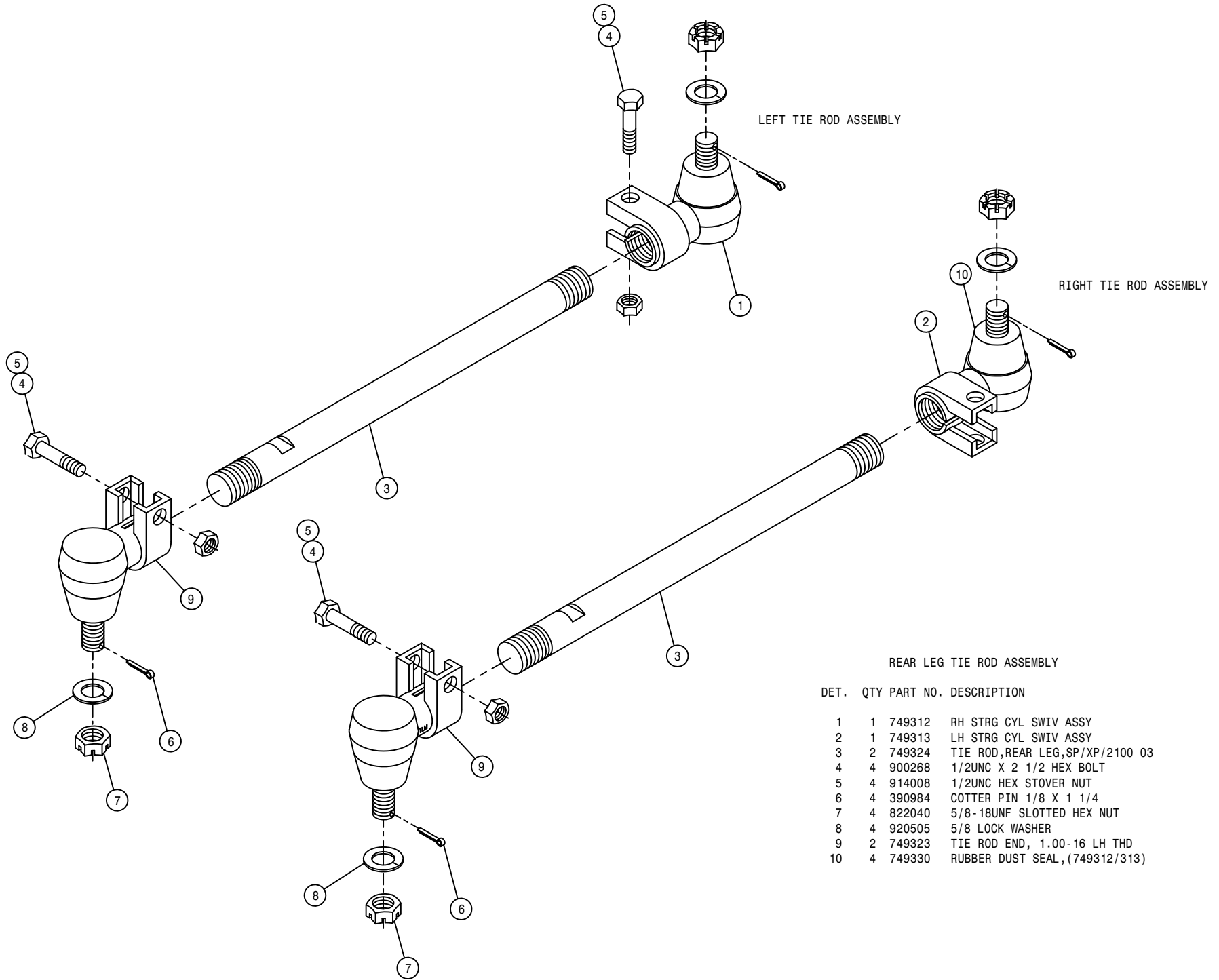

REAR LEG TIE ROD ASSEMBLY

DET.	QTY	PART NO.	DESCRIPTION
	1	749312	RH STRG CYL SWIV ASSY
	1	749313	LH STRG CYL SWIV ASSY
	2	749324	TIE ROD,REAR LEG,SP/XP/2100 03
	4	900268	1/2UNC X 2 1/2 HEX BOLT
	4	914008	1/2UNC HEX STOVER NUT
	4	390984	COTTER PIN 1/8 X 1 1/4
	4	822040	5/8-18UNF SLOTTED HEX NUT
	4	920505	5/8 LOCK WASHER
	2	749323	TIE ROD END, 1.00-16 LH THD
	4	749330	RUBBER DUST SEAL,(749312/313)

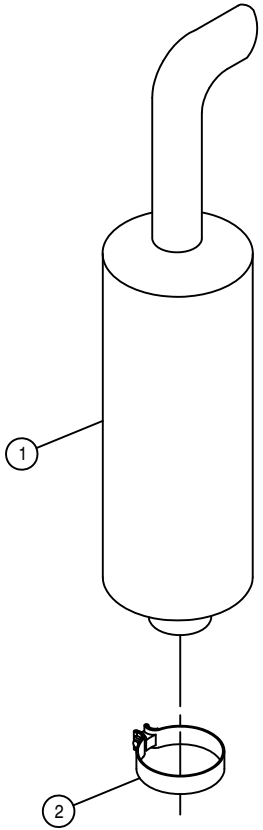

MUFFLER ASSEMBLY

DET.	QTY	PART NO.	DESCRIPTION
1	1	316366	MUFFLER, 2100/STS10/STS12
2	1	470458	MUFFLER CLAMP, 3.00 ACCUSEAL

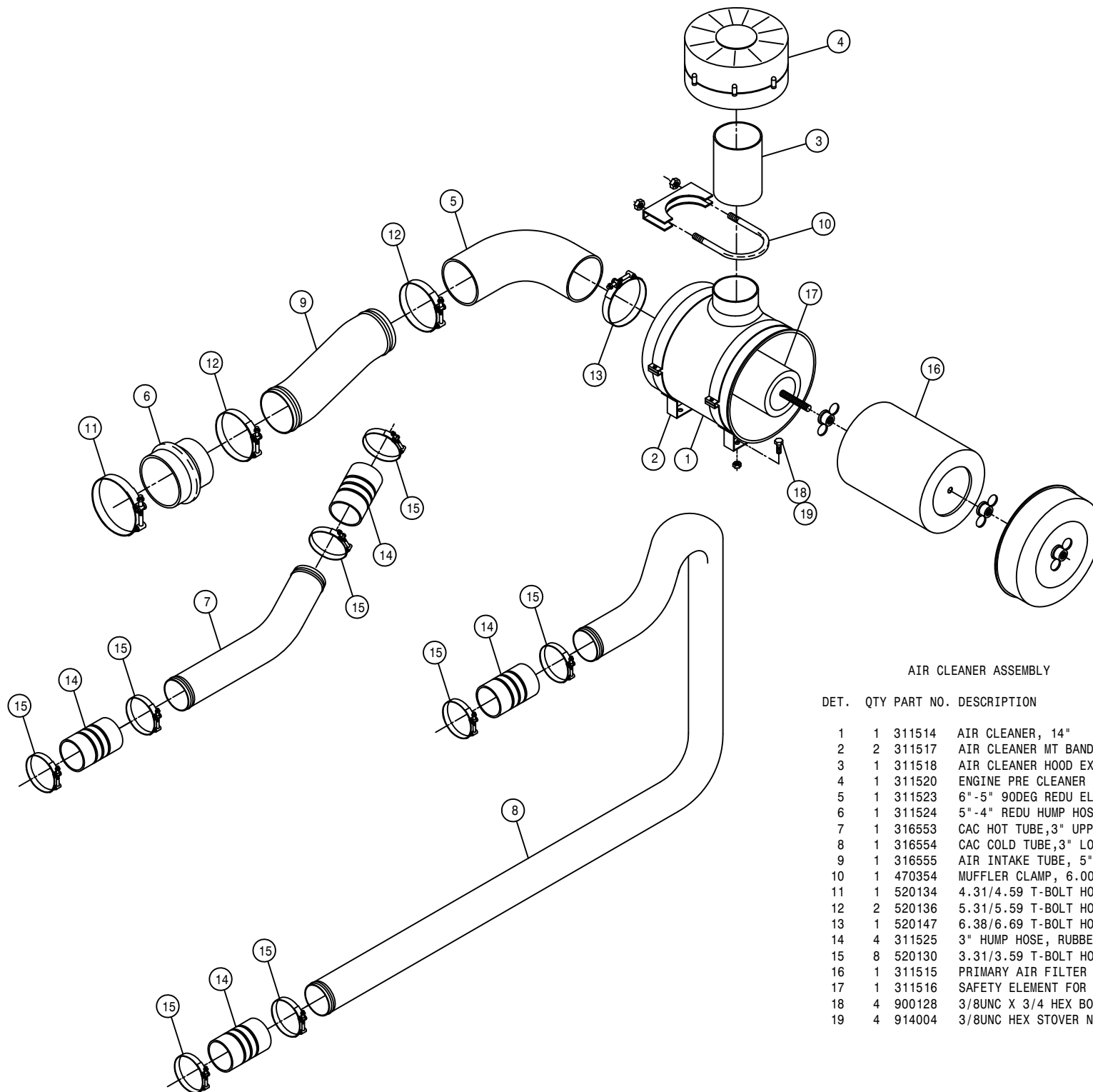

AIR CLEANER ASSEMBLY

DET.	QTY	PART NO.	DESCRIPTION
1	1	311514	AIR CLEANER, 14" STS 03
2	2	311517	AIR CLEANER MT BAND,14" STS 03
3	1	311518	AIR CLEANER HOOD EXT,6" X 8"LG
4	1	311520	ENGINE PRE CLEANER
5	1	311523	6"-5" 90DEG REDU ELBOW,RUBBER
6	1	311524	5"-4" REDU HUMP HOSE, RUBBER
7	1	316553	CAC HOT TUBE,3" UPPER 2101 03
8	1	316554	CAC COLD TUBE,3" LOWER 2101 03
9	1	316555	AIR INTAKE TUBE, 5" 2101 03
10	1	470354	MUFFLER CLAMP, 6.00 STD U-BOLT
11	1	520134	4.31/4.59 T-BOLT HOSE CLAMP SS
12	2	520136	5.31/5.59 T-BOLT HOSE CLAMP SS
13	1	520147	6.38/6.69 T-BOLT HOSE CLAMP
14	4	311525	3" HUMP HOSE, RUBBER
15	8	520130	3.31/3.59 T-BOLT HOSE CLAMP SS
16	1	311515	PRIMARY AIR FILTER FOR 311514
17	1	311516	SAFETY ELEMENT FOR 311514
18	4	900128	3/8UNC X 3/4 HEX BOLT
19	4	914004	3/8UNC HEX STOVER NUT

CAB ASSEMBLY

DET. QTY PART NO. DESCRIPTION

1	26	193044	WINDOW WEATHERSTRIP
2	26	193045	LOCK STRIP FOR 193044
3	4	127502	NYLON FLANGE BRG
4	15	193062	SEAL, .592 X .750 D-SECT EDPM
5	5	193063	EDGE SEAL, EPDM G-7015
6	1	290412	DIMMER SWITCH
7	1	470417	STRIKER PIN ASSY
8	6	291603	HALOGEN WORKLAMP, SIDE MT 12V
9	1	343321	CAB WELD, DTS 10 05
10	1	343329	CAB ROOF, DTS 10 05
11	2	903883	10-32 X 1/2 PHIL PAN MACH SCR
12	2	659704	FOAM, 2" THK X 2" WIDE X 42" LG
13	2	470380	OBS>: 1/4-20 NUTSERT .027-.165
14	2	473862	1/4UNF X 5/8 HEX BOLT SS
15	1	473852	12MM-1.75 SERR FLANGE NUT, ZINC
16	1	342420	HEAD LINER ANGLE, RH, 2100 98
17	1	342642	SOLU SWITCH ADPTR BRKT, 2100 98
18	2	470067	GROMMET, .250ID .125GW .375GD
19	4	470070	GROMMET, .375ID .062GW .500GD
20	6	470100	3/8 INT TOOTH LOCK WASHER
21	2	470175	10-32 SER FLG NUT
22	1	470222	GRAB HANDLE, BLACK MOULDED
23	1	470229	IDENTIFICATION TIE, WHITE
24	7	470261	3/8UNC X 1" HEX CAP NUT, .75 CLIP ON
25	4	470262	3/8 X 1" BONDED SEALING WASH
26	1	472349	1/4 X 3/4 20THD-IN TEK TYPE
27	6	473779	10MM-1.50 HEX NUT
28	2	470348	MIRROR STS10 & STS12
29	1	470436	MOTOR, WINDSHIELD WIPER, DTS 05
30	1	343330	GPS MT PLATE, DTS 10 05
31	1	658030	WINDSHIELD, GREEN DTS 10 05
32	1	658023	SIDE CAB GLASS, GRAY 2100 98
33	1	658024	REAR CAB GLASS, GRAY 2100 98
34	2	903708	1/4UNC X 1/2PHIL PANHD MACH SCR
35	2	900003	1/4UNC X 1" HEX BOLT
36	4	900829	5/8UNC X 4" HEX BOLT GR8
37	4	900129	3/8UNC X 1" HEX CAP BOLT
38	4	900263	1/2UNC X 1" HEX BOLT
39	2	914000	1/4UNC HEX STOVER NUT
40	4	914010	5/8UNC HEX STOVER NUT
41	1	290107	GROUND CABLE, 8" X 4GA .406LUGS
42	2	470087	3/8UNC HEX SER FLG NUT
43	1	900128	3/8UNC X 3/4 HEX BOLT YZ
44	4	311051	RUBBER MOUNT, RB3-350
45	4	311052	SNUBBING WASHER FOR 311051
46	1	470438	ARM, WNDSHLD WIPER BLADE, DTS 05
47	1	470437	BLADE, WNDSHLD WIPER 32" DTS 05

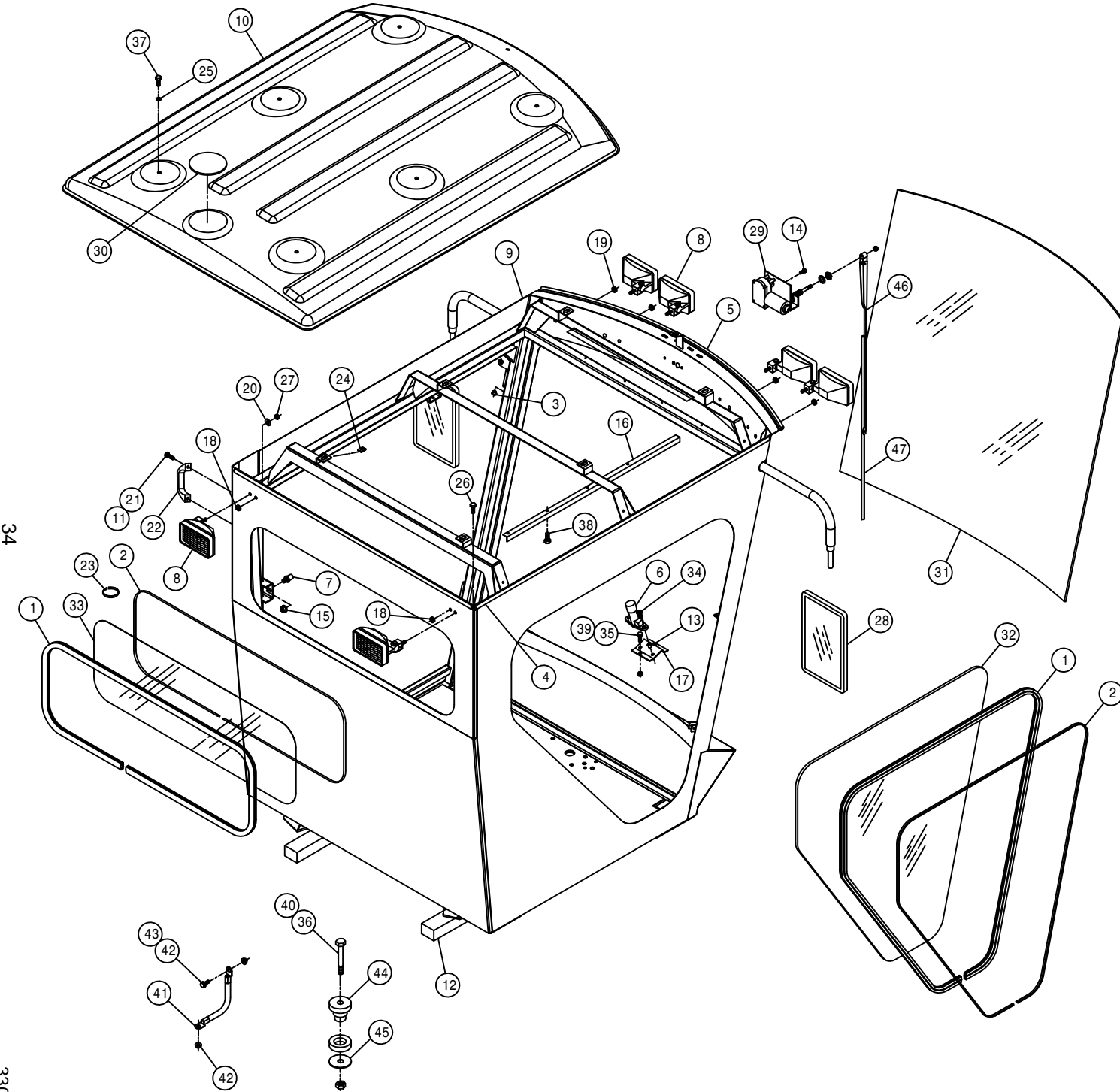

34

330034

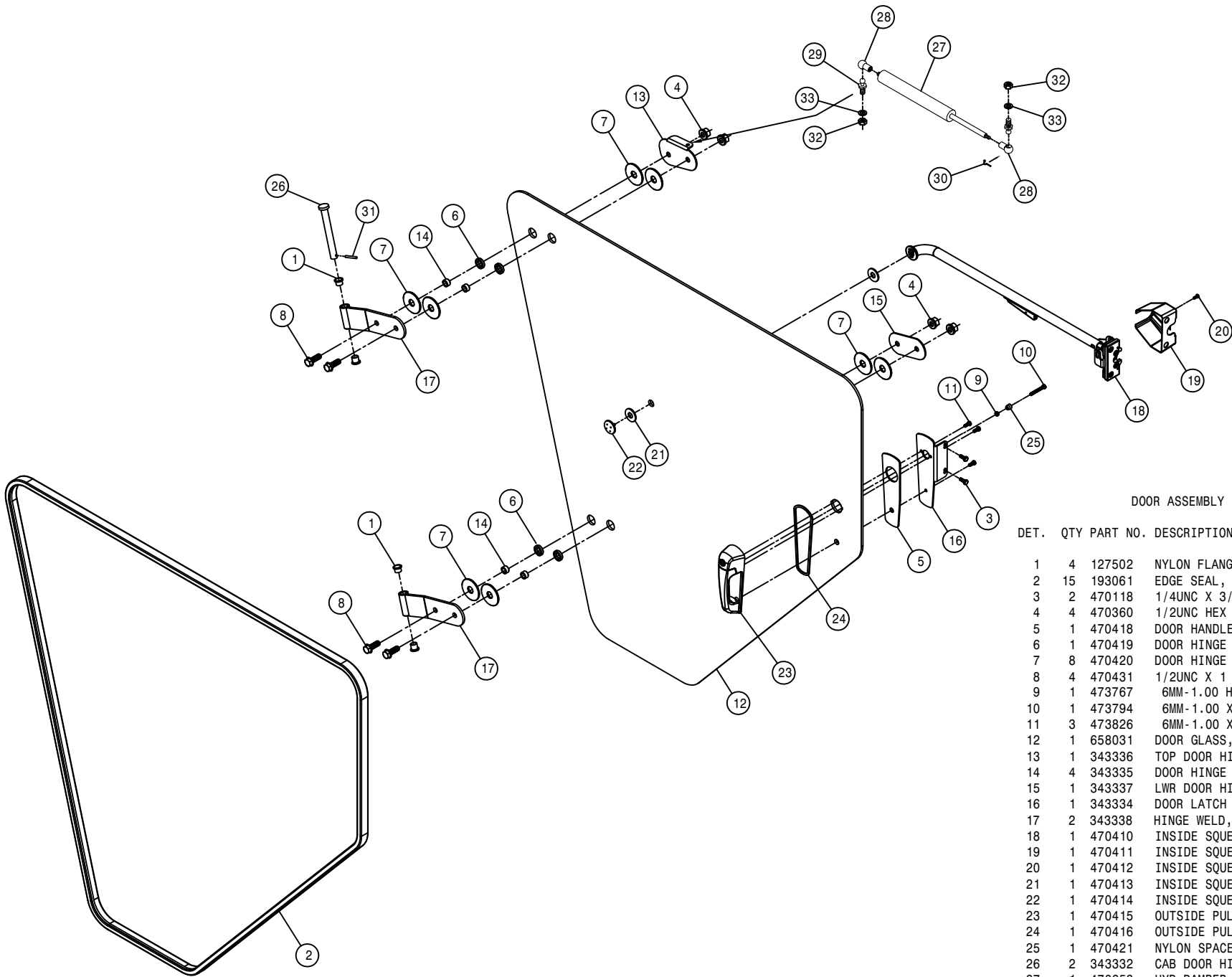

DOOR ASSEMBLY

DET.	QTY	PART NO.	DESCRIPTION
1	4	127502	NYLON FLANGE BRG
2	15	193061	EDGE SEAL, CLEAN GRIP EPDM
3	2	470118	1/4UNC X 3/4 FLANGE HEX BOLT
4	4	470360	1/2UNC HEX FLANGE LOCK NUT
5	1	470418	DOOR HANDLE MT GASKET, STS CAB
6	1	470419	DOOR HINGE BUSH, RUBBER STS 05
7	8	470420	DOOR HINGE WASH, RUBBER, STS 05
8	4	470431	1/2UNC X 1 1/2 FLANGE BOLT
9	1	473767	6MM-1.00 HEX NUT
10	1	473794	6MM-1.00 X 50MM HEX BOLT
11	3	473826	6MM-1.00 X 16MM HEX BOLT
12	1	658031	DOOR GLASS, GRAY DTS 10 05
13	1	343336	TOP DOOR HINGE PLT, DTS 10, 05
14	4	343335	DOOR HINGE GLASS BUSH, CAB 05
15	1	343337	LWR DOOR HINGE BACK PLT, 05
16	1	343334	DOOR LATCH BRKT PLT, CAB 05
17	2	343338	HINGE WELD, CAB 05
18	1	470410	INSIDE SQUEEZE LATCH ASSY
19	1	470411	INSIDE SQUEEZE LATCH COVER
20	1	470412	INSIDE SQUEEZE LATCH SCREWS
21	1	470413	INSIDE SQUEEZE LATCH GASKET
22	1	470414	INSIDE SQUEEZE LATCH CAP
23	1	470415	OUTSIDE PULL HANDLE ASSY
24	1	470416	OUTSIDE PULL HANDLE GASKET
25	1	470421	NYLON SPACER, SPHERICAL 6MMX12
26	2	343332	CAB DOOR HINGE PIN, SS 05
27	1	470253	HYD DAMPER, 100LB, 4" STROKE 1084
28	2	470254	BALL SOCKET, M6 THD X 10MM
29	2	470255	BALL STUD, 5/16-18 THD X 10MM
30	1	470256	SAFTY CLIP, 10MM BALL SOCKET
31	2	473928	ROLL PIN, 3/16 X 1
32	2	910002	5/16UNC HEX NUT
33	2	920501	5/16 LOCK WASHER

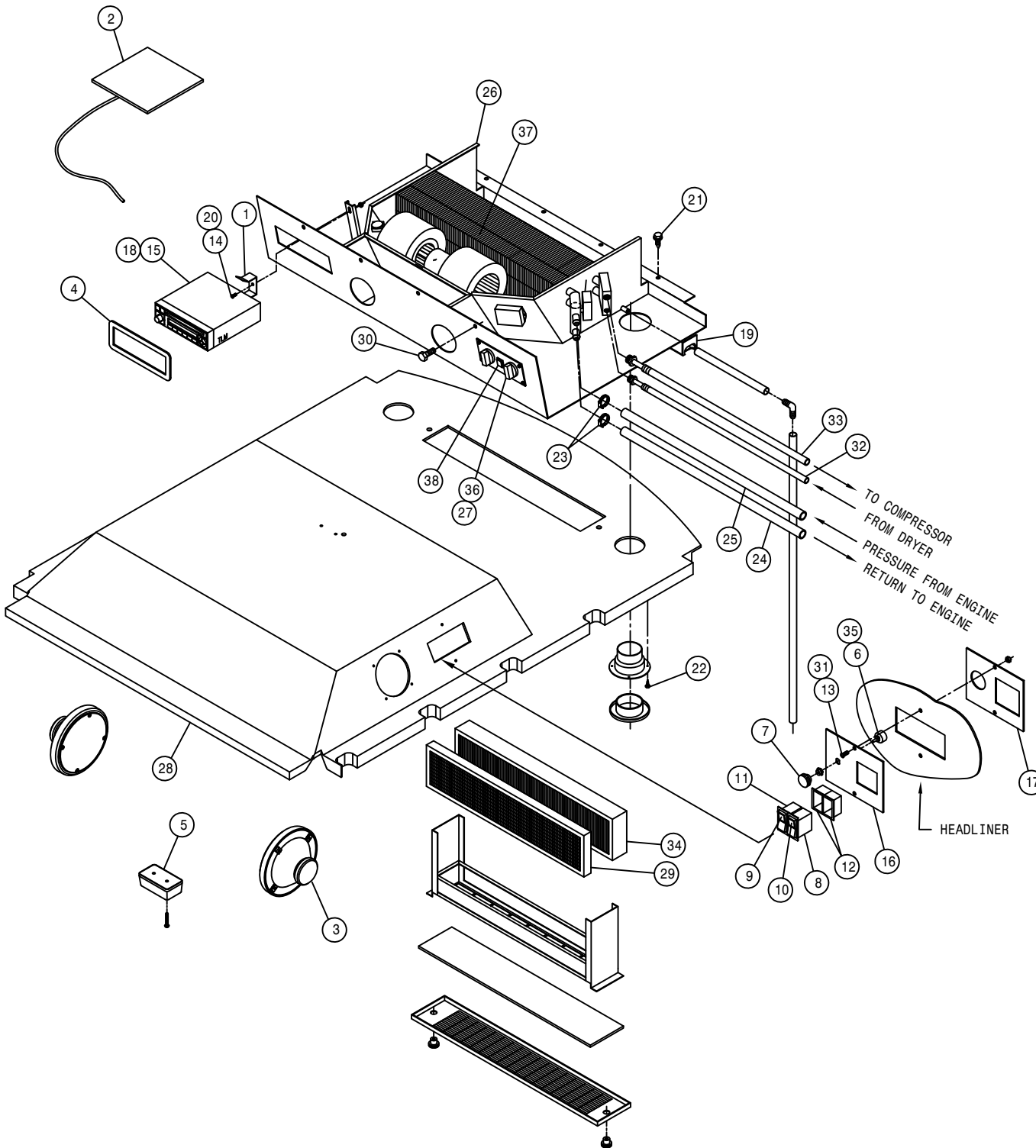

AIR CONDITIONER ASSEMBLY

DET.	QTY	PART NO.	DESCRIPTION
1	1	291834	RADIO SUPPORT BRKT
2	1	291924	ANTENNA AM/FM/WB HEADLINER MT
3	2	291922	SPEAKERS,PAIR
4	1	343331	RADIO BEZEL,CAB
5	1	291605	INTERIOR LIGHT W/SWITCH
6	1	291606	ROTARY HEADLAMP SWITCH
7	1	291607	SWITCH KNOB FOR 291606
8	1	291622	SWITCH,1P ON/OFF 511-003
9	1	291630	LENS,WINDSHIELD WASHER,594-701
10	1	291631	LENS, HAZARD 595-417
11	1	291678	SWITCH, 511-115
12	2	293246	END BEZEL, 594-802
13	2	903710	10-32X5/8 PHIL PANHD MACH SCR
14	1	903883	10-32 X 1/2 SLT RDHD MACH SCR
15	1	291920	RADIO CRW200
16	1	342421	LIGHT SWITCH PANEL, 2100 98
17	1	342633	LIGHT SWITCH PANEL KPR,2100 98
18	1	291925	RADIO WIRE HARNESS, DTS 05
19	2	342669	A/C DRAIN HOSE KEEPER
20	1	470175	10-32 HEX FLANGE LOCK NUT
21	4	472349	1/4 X 3/4 20THD-IN TEK TYPE
22	24	473966	6X3/4 PHIL FLT HD SHT MTL SCR
23	2	520055	HOSE CLAMP NO 12 STAINLESS
24	1	601637	HOSE, 5/8 X 196 HEATER
25	1	601638	HOSE, 5/8 X 254 HEATER
26	1	657462	A/C-HTR BLOWER SYS, DTS10 05
27	2	657415	A/C POTENTIOMETER ASSY
28	1	658332	HEADLINER, DTS 10 05
29	1	657425	A/C CHARCOAL AIR FILTER
30	4	900128	3/8UNC X 3/4 HEX BOLT
31	2	914027	10-32 HEX STOVER NUT
32	1	657465	A/C HOSE ASSY, 5/16 X 202
33	1	657466	A/C HOSE ASSY, 1/2 X 202
34	1	657424	A/C PAPER AIR FILTER
35	1	903844	8-32 X 1/2 SLT RD HD MACH SCR
36	2	657409	A/C CONTROL KNOB
37	1	657407	A/C HEATER COIL
38	1	657410	A/C SWITCH, PUSH ON-OFF

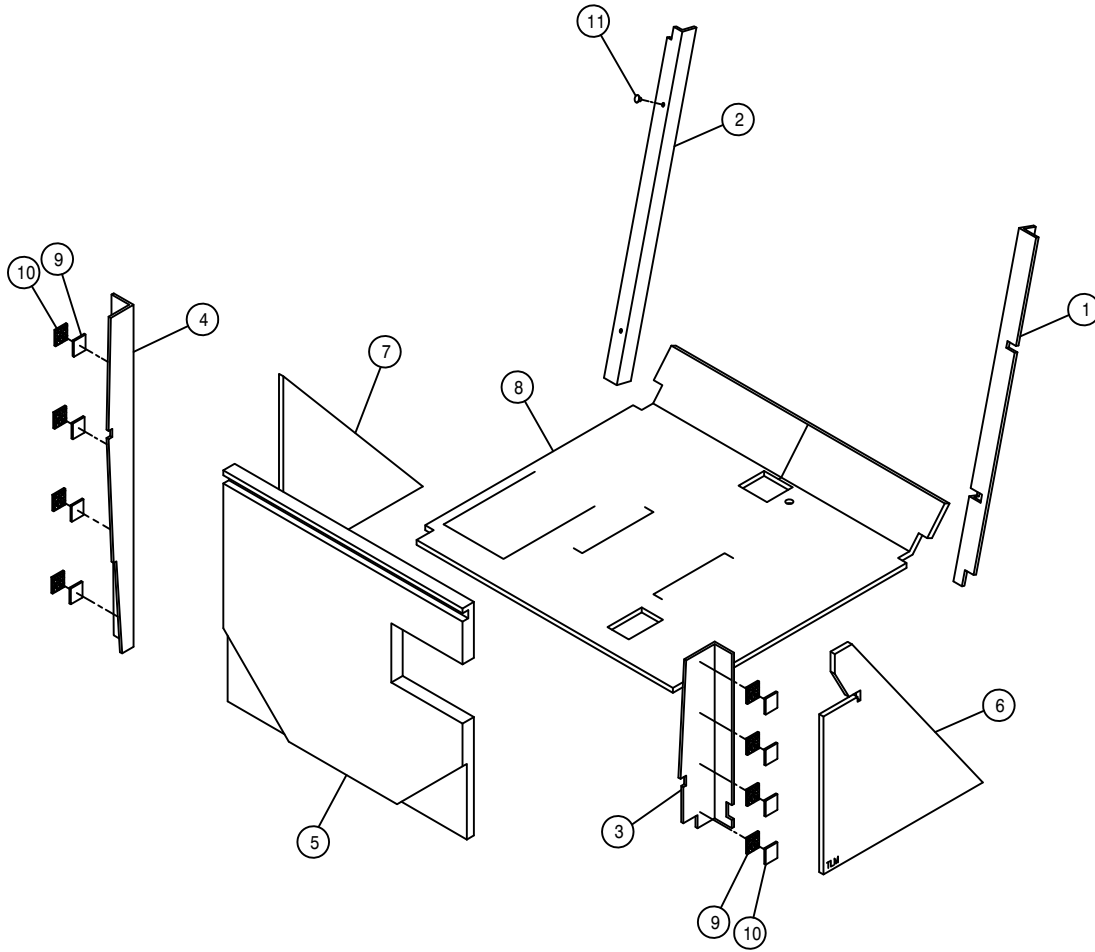

FOAM

DET. QTY PART NO. DESCRIPTION

1	1	658329	POST COVER, RH FRONT, 2101	03
2	1	658320	POST COVER, LH FRONT	2100 98
3	1	658321	POST COVER, RH REAR	2100 98
4	1	658322	POST COVER, LH REAR	2100 98
5	1	658323	BACKPANEL, 2100	98
6	1	658324	SIDE PANEL, RH 2100	98
7	1	658325	SIDE PANEL, LH 2100	98
8	1	658326	FLOORMAT, 2100	98
9	8	471101	DUAL LOCK, 1.00 X 1.00	SJ3542
10	8	471100	DUAL LOCK, 1.00 X 1.00	SJ3541
11	2	470225	TRIM CLIP, 11/16 BLK NYL HEAD	

STEERING POST ASSEMBLY

DET.	QTY	PART NO.	DESCRIPTION
	1	2	127502 NYLON FLANGE BRG
	2	3	127503 NYLINER FLG BRG, .875 ID
	3	1	291088 FLASHER / TURN SIGNAL SWITCH
	4	1	342450 LWR STRG COLUMN WLD, 2100 98
	5	1	342454 UPPER STRG COLUMN WLD, 2100 98
	6	1	342461 STRG WHL MT WLD, 2100 98
	7	1	342467 UPPER STRG COLUMN COVER,2100 98
	8	1	342468 CNTR STRG COLUMN COVER,2100 98
	9	1	342469 LWR STRG COLUMN SHLD
	10	1	342470 STRG COLUMN PIVOT PIN, 2100 98
	11	1	342471 STRG COL BRG HSNGL WLD, 2100 98
	12	1	342474 UPPER STEERING SHAFT, 2100 98
	13	1	470285 DOUBLE UNIVERSAL JOINT DRIVER
	14	4	470346 GROMMET, .500ID .250GW, .812GD
	15	4	920502 3/8 LOCK WASHER
	16	1	342483 LWR STEERING SHAFT, 2100 98
	17	1	342484 FOOT PEDAL PIV PIN WLD,2100 98
	18	1	342487 FOOT PEDAL WLD, 2100 98
	19	1	342490 STRG PIVOT LOCK, 2100 98
	20	1	342491 LWR AIR SHOCK PIVOT, 2100 98
	21	2	342492 LWR AIR SHOCK PIV BUSH,2100 98
	22	2	390318 INDICATOR LIGHT, RED
	23	10	470380 1/4-20 NUTSERT .027-.165 STL
	24	1	470157 13/16-20UNEF HEX NUT STRG WHL
	25	1	470252 GAS SPRING, LOCKING 0350N
	26	1	470257 ADJ HANDLE,3/8-16 STUD, BLACK
	27	1	470268 SPRING, EXTENSION, .50 X 1.75
	28	2	470283 3/8UNC 1/2 SCKT SHLDR BOLT
	29	2	473830 10MM-1.00 HEX JAM NUT
	30	3	473928 ROLL PIN, 3/16 X 1
	31	1	473936 ROLL PIN, 3/16 X 1 1/4
	32	2	629525 RING, RETAINING, .50DIA SHAFT
	33	2	629533 SNAP RING, 7/8 EXTRN
	34	2	900065 5/16UNC X 1" HEX BOLT
	35	1	900067 5/16UNC X 1 1/2 HEX BOLT
	36	8	900128 3/8UNC X 3/4 HEX BOLT
	37	10	903708 1/4UNC X1/2 PHIL PNHD MACHSCR
	38	3	914002 5/16UNC HEX STOVER NUT
	39	4	914004 3/8UNC HEX STOVER NUT
	40	1	920002 3/8 SAE FLAT WASHER
	41	1	920007 7/8 SAE FLAT WASHER
	42	1	749294 STEERING WHEEL, VIP 14"
	43	1	749295 STRG WHL CAP W/HAGIE EMBLEM
	44	4	900267P 1/2UNC X 2" HEX BOLT
	45	4	470124P 1/2UNC HEX JAM NUT
	46	4	920004 1/2 SAE FLAT WASHER
	47	1	343211 STEERING MTR PLT,284XP/2100 02
	48	1	618109 9/16MJIC-3/4MOR ADPTR
	49	1	749318 STRG MTR,7.3CID,NON-LOAD 1031
	50	2	483031 1 3/8 X 7/8 X 18GA MACH WASHER
	51	1	470342 SNAP PLUG, BLK NYL, .375 DIA
	52	4	470345P 1/2UNC HEX SMTH FLNG LOCK NUT

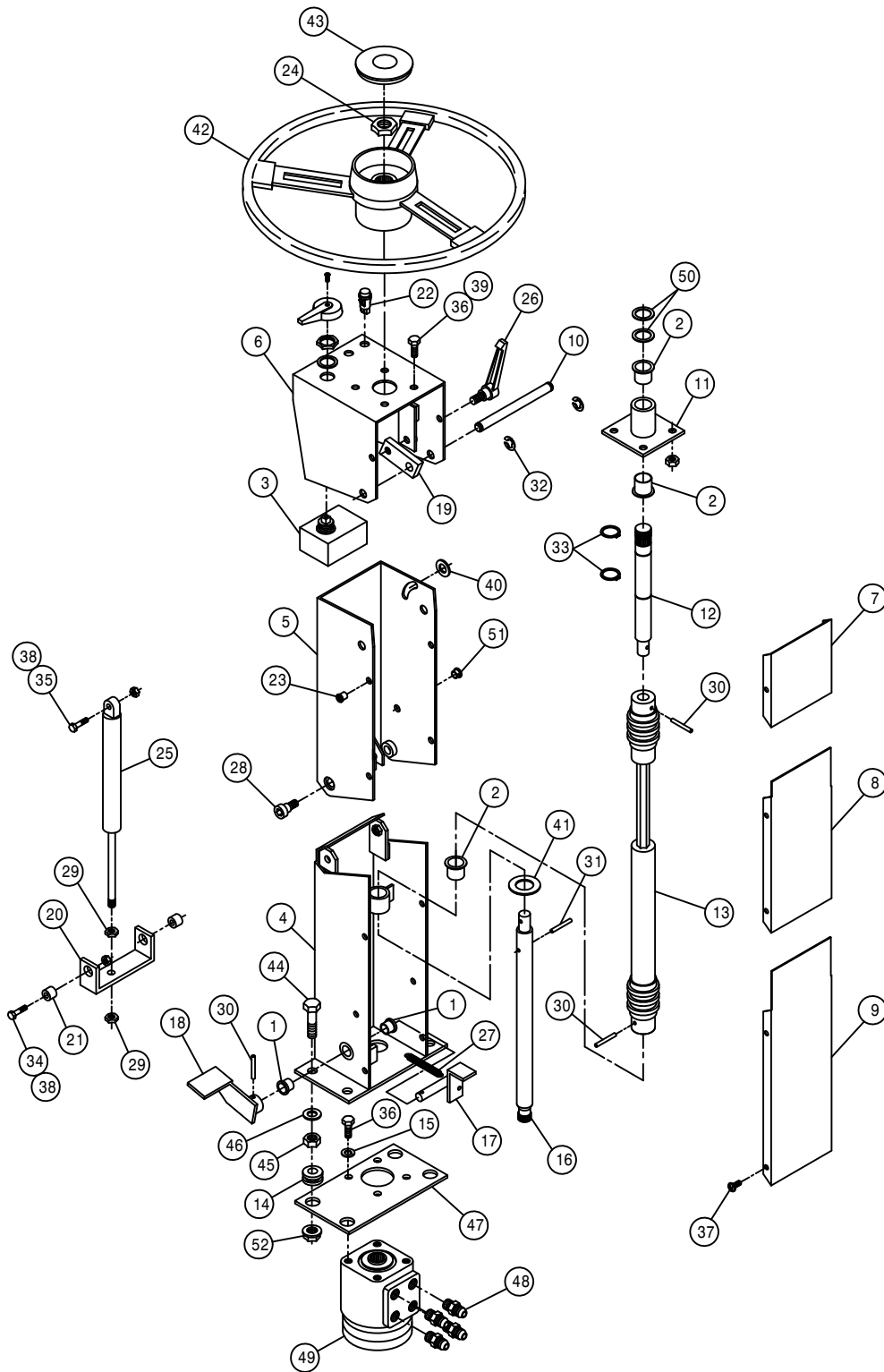

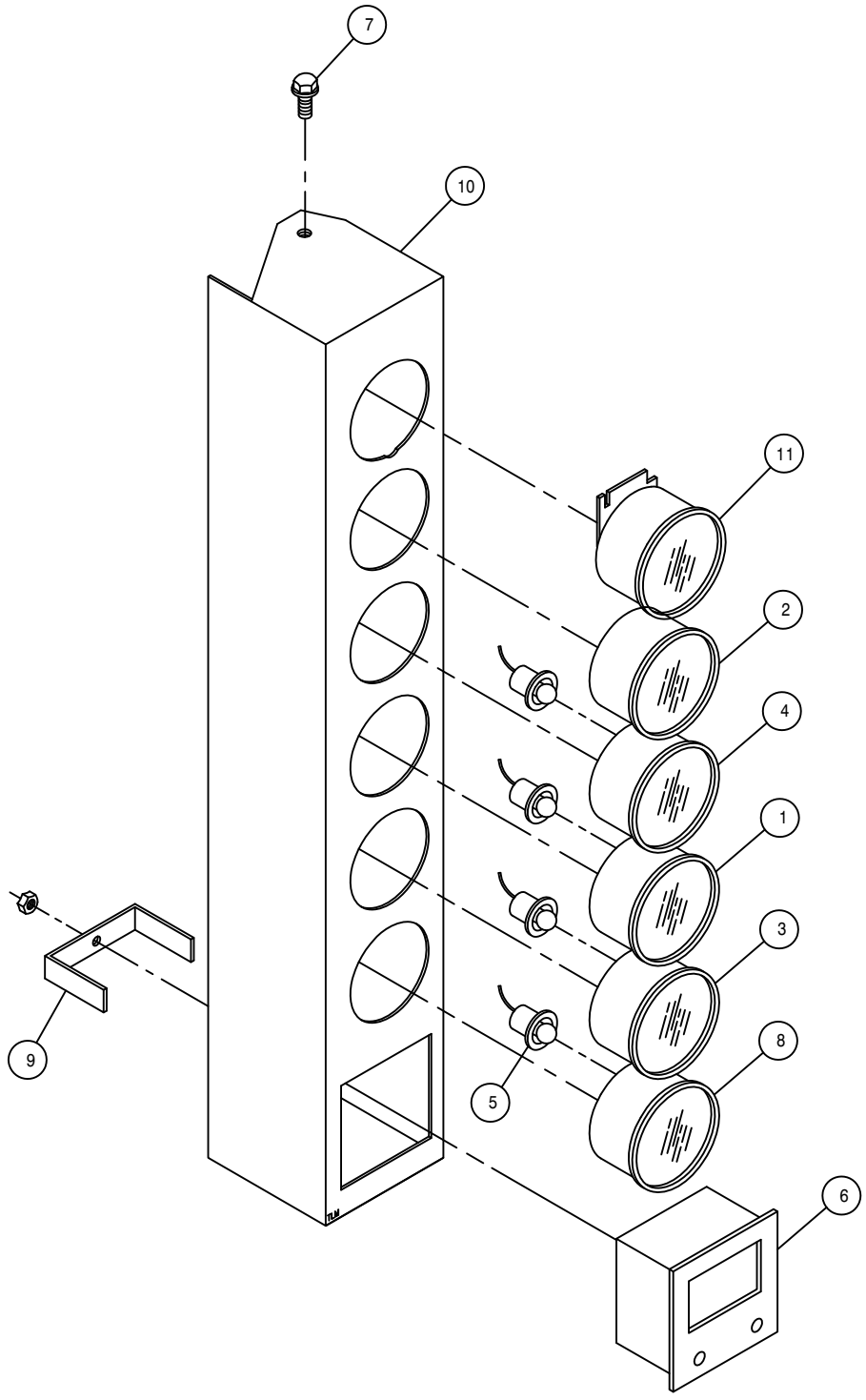

INSTRUMENT PANEL ASSEMBLY

DET.	QTY	PART NO.	DESCRIPTION
	1	290401	FUEL GAUGE FOR 2.125 DIA HOLE
	1	291203	HOUR METER, 10/80VDC BLACK BEZ
	1	291673	OIL PRESS GAUGE, 125PSI
	1	291611	VOLTMETER, 8V TO 18V DC
	4	291612	LIGHT KIT FOR 2" GAUGE
	1	291635	DIGITAL MPH/RPM INDICATOR
	2	470122	1/4UNC X 1/2 FLANGE HEX BOLT
	1	314436	TEMP GA 100-280 DEG LIGHTED
	1	342068	DIGITAL MPH/RPM IND KEEPER 94
	1	343249	INSTRU HSNGL WLD, 2101 03
	1	291853	ENG WARNING LIGHT CLUSTER, 2"

CONSOLE COVER ASSEMBLY

DET.	QTY	PART NO.	DESCRIPTION
1	4	291627	SWITCH,2P(ON)OFF(ON) 511-058
2	5	291628	LENS, GREEN 596-650
3	1	291671	SWITCH,2P OFF/ONA/ONAB 511-138
4	2	293247	CENTER BEZEL, 594-801
5	1	343252	CONSOLE TOP WLD, 2101 03
6	1	342509	CONSOLE LID ASSY, 2100 98
7	4	473966	6X3/4 PHIL FLT HD SHT MTL SCR
8	6	903710	10-32X5/8 PHIL PANHD MACH SCR
9	2	293246	END BEZEL, 594-802

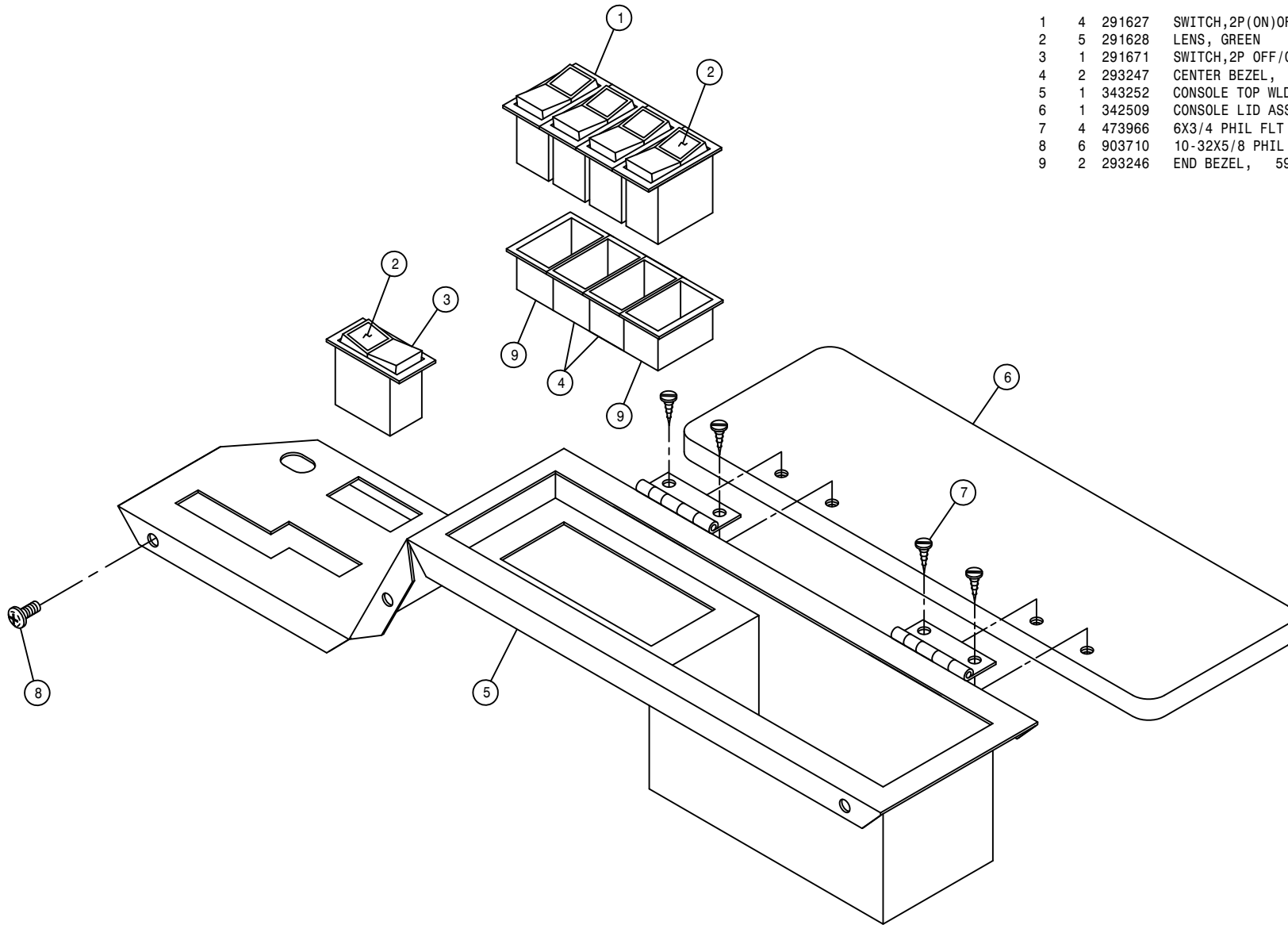

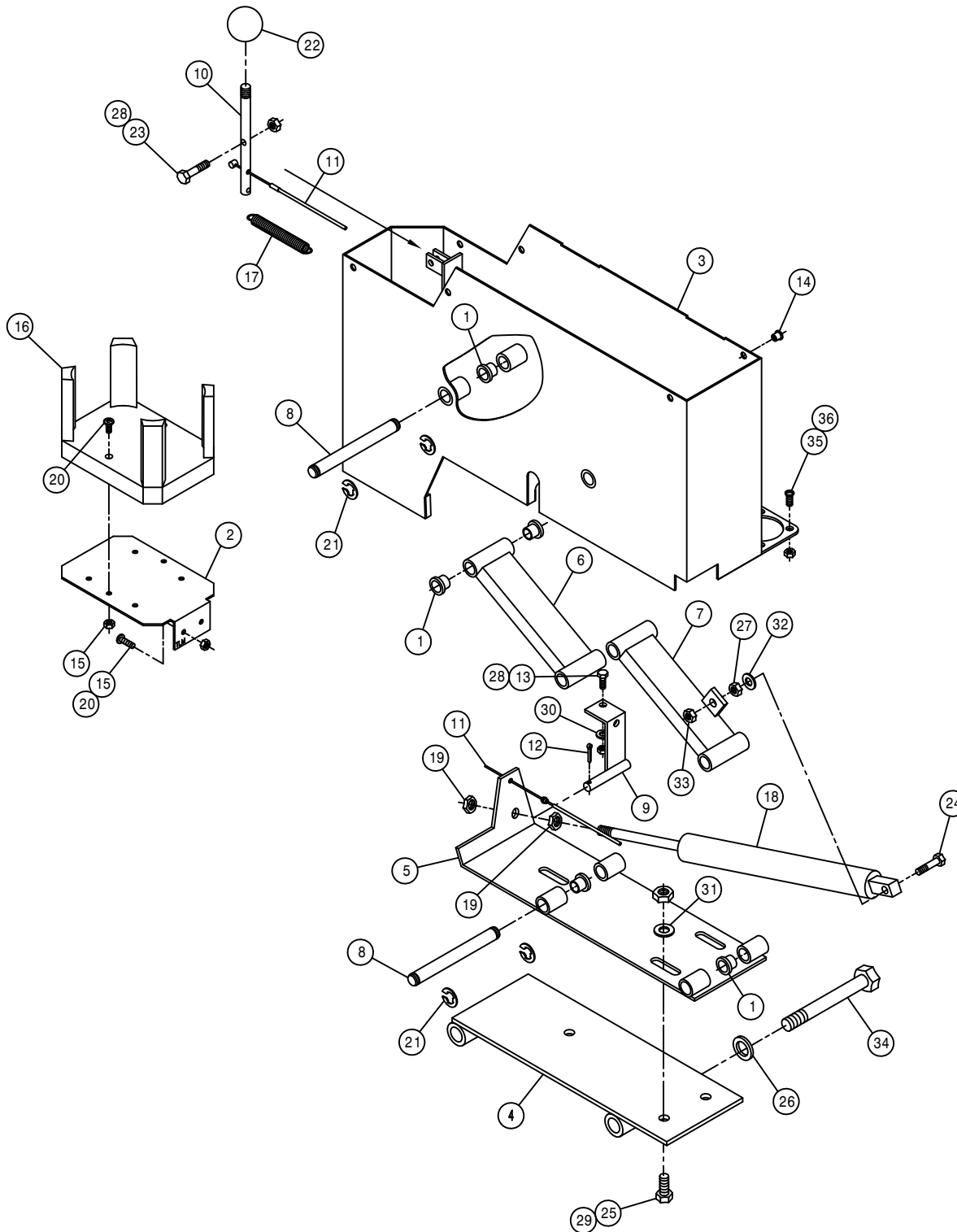

CONSOLE ASSEMBLY

DET. QTY PART NO. DESCRIPTION

1	16	127504	NYLINER FLG BRG, .500 ID	
2	1	342216	DRINK HOLDER MT BRKT	94
3	1	343254	CONSOLE WLD, 2101	03
4	1	342510	CONSOLE SEAT MT WLD, 2100	98
5	1	342513	LWR CONSOLE MTG PLT WLD2100	98
6	1	342516	FRT CONSOLE PIVOT BRKT WLD	98
7	1	342519	REAR CONSOLE PIVOT BRKT WLD	98
8	4	342522	CONSOLE PIN, 2100	98
9	1	342523	AIR SHOCK RELEASE WLD, 2100	98
10	1	342526	ADJ HANDLE, 2100	98
11	1	342527	CONSOLE ADJ CABLE ASSY,2100	98
12	1	470006	COTTER PIN 1/8 X 1	
13	1	470118	1/4UNC X 3/4 FLANGE HEX BOLT	
14	6	470165	10-32 NUTSERT .020-.100 MATL	
15	4	470175	10-32 HEX FLANGE LOCK NUT	
16	1	470214	SPILLMASTER DRINK HOLDER	
17	1	470248	SPRING,EXPANSION .438 X 3.00	
18	1	470251	GAS SPRING, LOCKING 0250N	
19	2	473830	10MM-1.00 HEX JAM NUT	
20	4	903710	10-32X5/8 PHIL PANHD MACH SCR	
21	8	629525	RING, RETAINING, .50DIA SHAFT	
22	1	659291	KNOB,1" RND,BLK, 3/8-16	
23	1	900003	1/4UNC X 1" HEX BOLT	
24	1	900067	5/16UNC X 1 1/2 HEX BOLT	
25	3	900129	3/8UNC X 1" HEX BOLT	
26	2	920505	5/8 LOCK WASHER	
27	1	910002	5/16UNC HEX NUT	
28	2	914000	1/4UNC HEX STOVER NUT	
29	3	914004	3/8UNC HEX STOVER NUT	
30	1	920000	1/4 SAE FLAT WASHER	
31	3	920002	3/8 SAE FLAT WASHER	
32	1	920001	5/16 SAE FLAT WASHER	
33	1	914002	5/16UNC HEX STOVER NUT	
34	2	900346	5/8UNC X 6" HEX BOLT	
35	4	903812	6-32 X 1/2 SLT RD HD MACH SCR	
36	4	910022	6-32 HEX NUT	

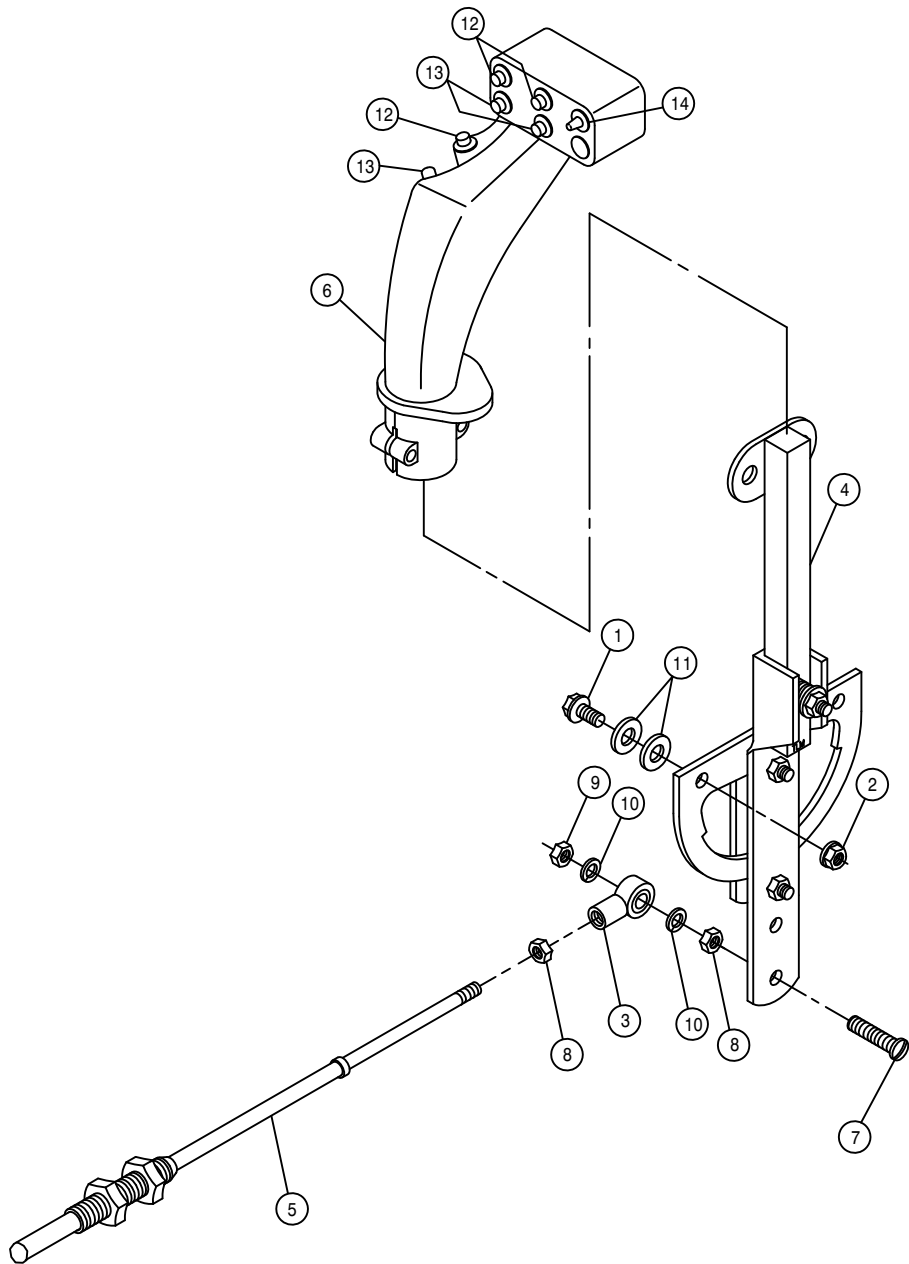

HYDROSTATIC LEVER ASSEMBLY

DET.	QTY	PART NO.	DESCRIPTION
	2	470118	1/4UNC X 3/4 FLANGE HEX BOLT
	2	470121	1/4UNC HEX FLANGE LOCK NUT
	1	473921	BALL JOINT NO 10-32 THD
	1	342528	HYDST CTRL LEVER ASSY, 2100 98
	1	785066	CTRL CABLE 10-32 4IN X 129 IN
	1	785086	FASSE CTRL HANDLE, C12L4T28
	1	903893	10-32 X 1" SLT RD HD MACH SCR
	2	910027	10-32 HEX NUT
	1	914027	10-32 HEX STOVER NUT
	2	920510	#10 LOCK WASHER
	4	920000	1/4 SAE FLAT WASHER
	3	291884	SWITCH,PB 3TRM MOM 0, GRAY
	3	291883	SWITCH,PB 3TRM MOM 0, RED
	1	291653	SWITCH, TOG SPDT 3POS STAT

SWITCH PANEL ASSEMBLY

DET.	QTY	PART NO.	DESCRIPTION	
1	3	291622	SWITCH,1P ON/OFF	511-003
2	1	291623	SWITCH,2P ON/OFF	511-015
3	7	291625	SWITCH,2P ON/ON	511-108
4	6	291627	SWITCH,2P(ON)OFF(OFF)	511-058
5	19	291628	LENS, GREEN	596-650
6	1	291638	INDICATOR LIGHT, GREEN	
7	1	291647	DUAL BINDING POSTS	
8	2	629768	CAPPLUGS CAP, .093 X .750 VINYL	
9	2	291775	SWITCH, LOCK OFF/ON	511-172
10	1	291776	BLANK COVER, 596-273	
11	8	293246	END BEZEL, 594-802	
12	13	293247	CENTER BEZEL, 594-801	
13	1	321021	IGN SWITCH, NON-SEALED	
14	1	342428	MONITOR BRKT, 2100	98
15	1	342532	BOOM SWITCH PANEL, 2100	98
16	1	343246	SWITCH PANEL, 2101	03
17	1	343256	SWITCH HOUSING WLD, 2101	03
18	1	390318	INDICATOR LIGHT, RED	
19	1	470070	GROMMET, .375ID .062GW .500GD	
20	14	470380	1/4-20 NUTSERT .027-.165 STL	
21	2	470118	1/4UNC X 3/4 FLANGE HEX BOLT	
22	2	470121	1/4UNC HEX FLANGE LOCK NUT	
23	4	470339	SNAP PLUG, BLK NYL, .250 DIA	
24	1	690618	CONSOLE, RAVEN 460 W/GPS PORT	
25	2	900000	1/4UNC X 1/2 HEX BOLT	
26	10	903708	1/4UNC X1/2 PHIL PNHND MACHSCR	
27	3	914000	1/4UNC HEX STOVER NUT	
28	1	342425	SWITCH HSG SUPP WLD, 2100	98
29	4	900002	1/4UNC X 3/4 HEX BOLT	
30	1	900005	1/4UNC X 1 1/2 HEX BOLT	
31	4	920000	1/4 SAE FLAT WASHER	
32	4	920500	1/4 LOCK WASHER	
33	1	291626	SWITCH,2P ON/OFF/ON	511-053
34	1	291005	LENS, RED	596-615

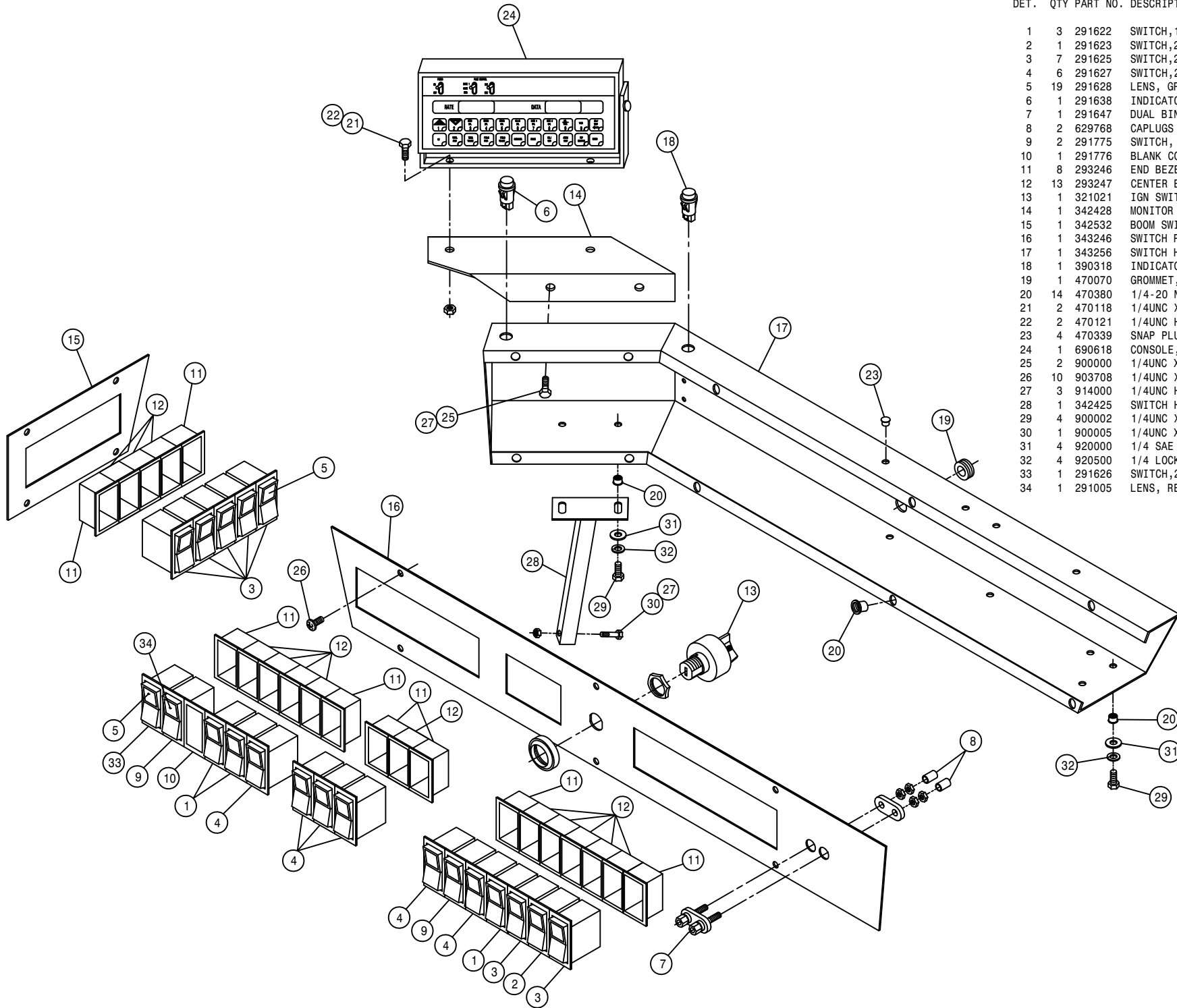

43

330043

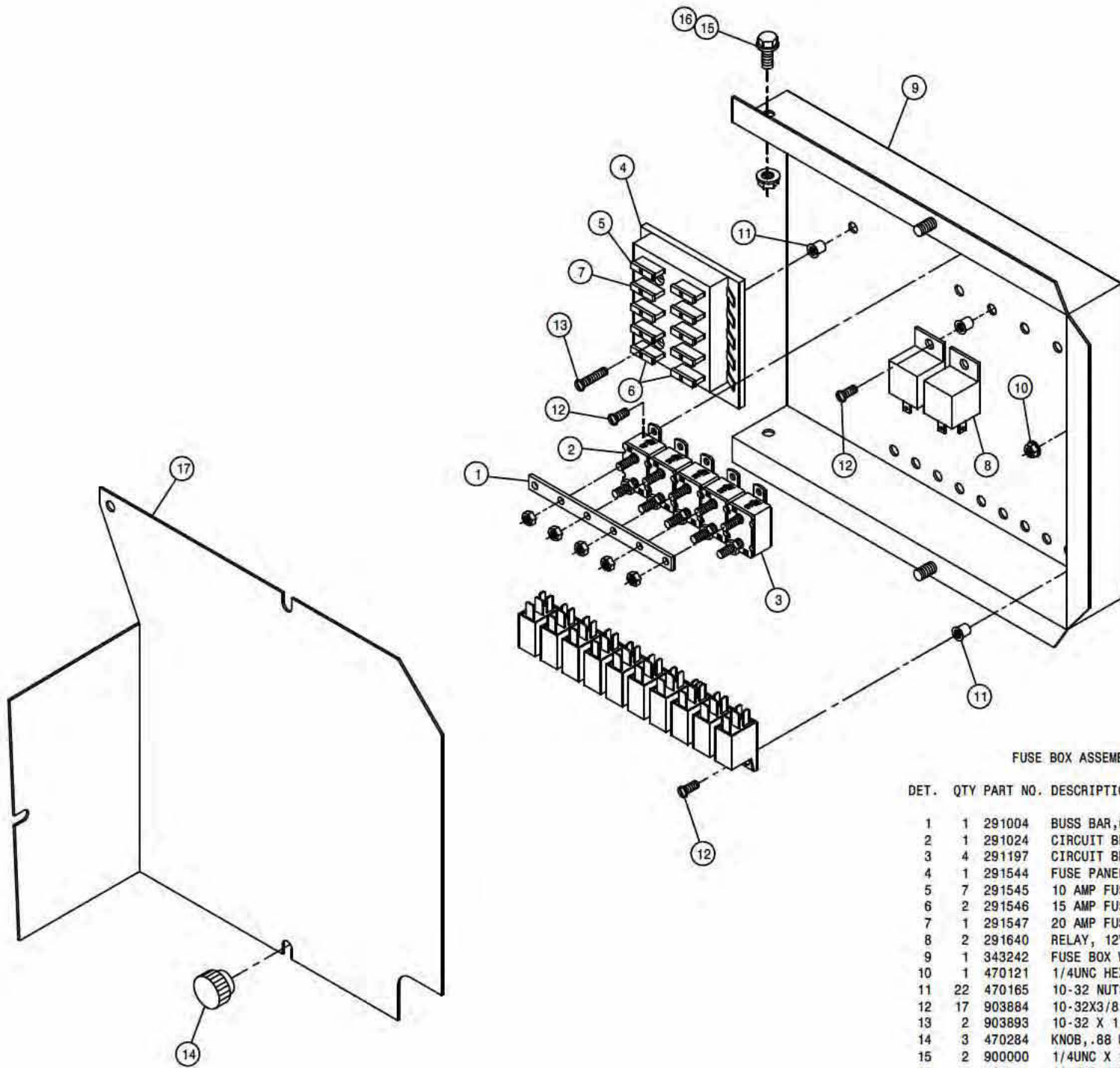

FUSE BOX ASSEMBLY

DET. QTY PART NO. DESCRIPTION

DET.	QTY	PART NO.	DESCRIPTION
1	1	291004	BUSS BAR, 6 GANG CIRCUIT BREAKR
2	1	291024	CIRCUIT BREAKER, 40AMP, INLINEMT
3	4	291197	CIRCUIT BREAKER, 30AMP, INLINEMT
4	1	291544	FUSE PANEL, 10 CIRCUIT, BLADE TP
5	7	291545	10 AMP FUSE, 1/4" BLADE ATO/ATC
6	2	291546	15 AMP FUSE, 1/4" BLADE ATO/ATC
7	1	291547	20 AMP FUSE, 1/4" BLADE ATO/ATC
8	2	291640	RELAY, 12V 20/30AMP BOSCH
9	1	343242	FUSE BOX WLD, 2101/2101C 03
10	1	470121	1/4UNC HEX FLANGE LOCK NUT
11	22	470165	10-32 NUTSERT .020-.100 MATL
12	17	903884	10-32X3/8 PHIL PANHD MACH SCR
13	2	903893	10-32 X 1" SLT RD HD MACH SCR
14	3	470284	KNOB, .88 KNRLD, BLK, 1/4-20
15	2	900000	1/4UNC X 1/2 HEX BOLT
16	2	914000	1/4UNC HEX STOVER NUT
17	1	342431	FUSE BOX COVER, 2100

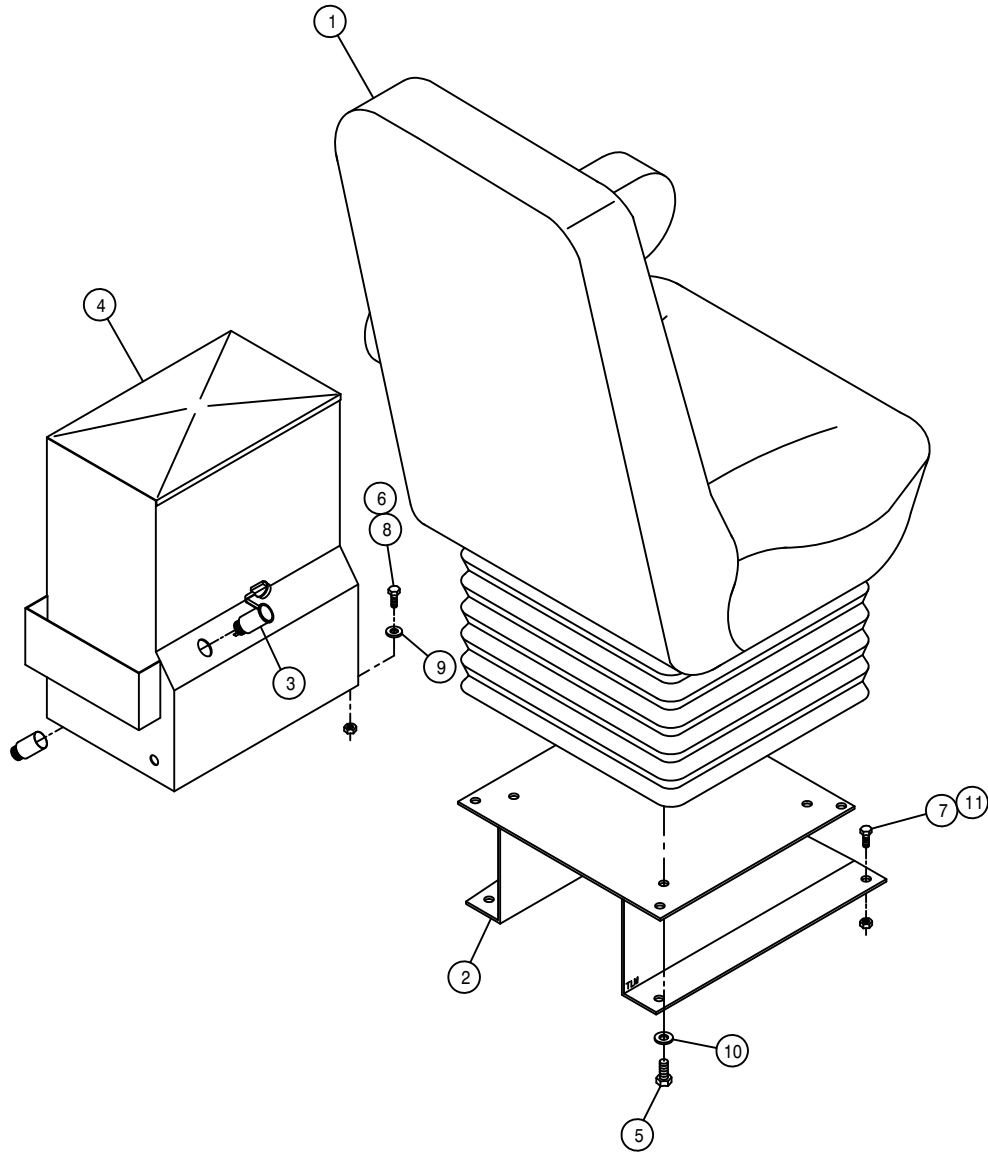

SEAT AND CONSOLE ASSEMBLY

DET. QTY PART NO. DESCRIPTION

1	1	330034	SEAT & AIR RIDE ASSY, STS	05
2	1	342090	SEAT MT WELD, 254/284	95
3	1	291648	POWER POINT RECEPTACLE	
4	1	342432	LH CONSOLE WLD, 2100	98
5	4	473803	8MM-1.25 X 16MM HEX BOLT	
6	4	900002	1/4UNC X 3/4 HEX BOLT	
7	4	900129	3/8UNC X 1" HEX BOLT	
8	4	914000	1/4UNC HEX STOVER NUT	
9	4	920000	1/4 SAE FLAT WASHER	
10	4	920501	5/16 LOCK WASHER	
11	4	914004	3/8UNC HEX STOVER NUT	

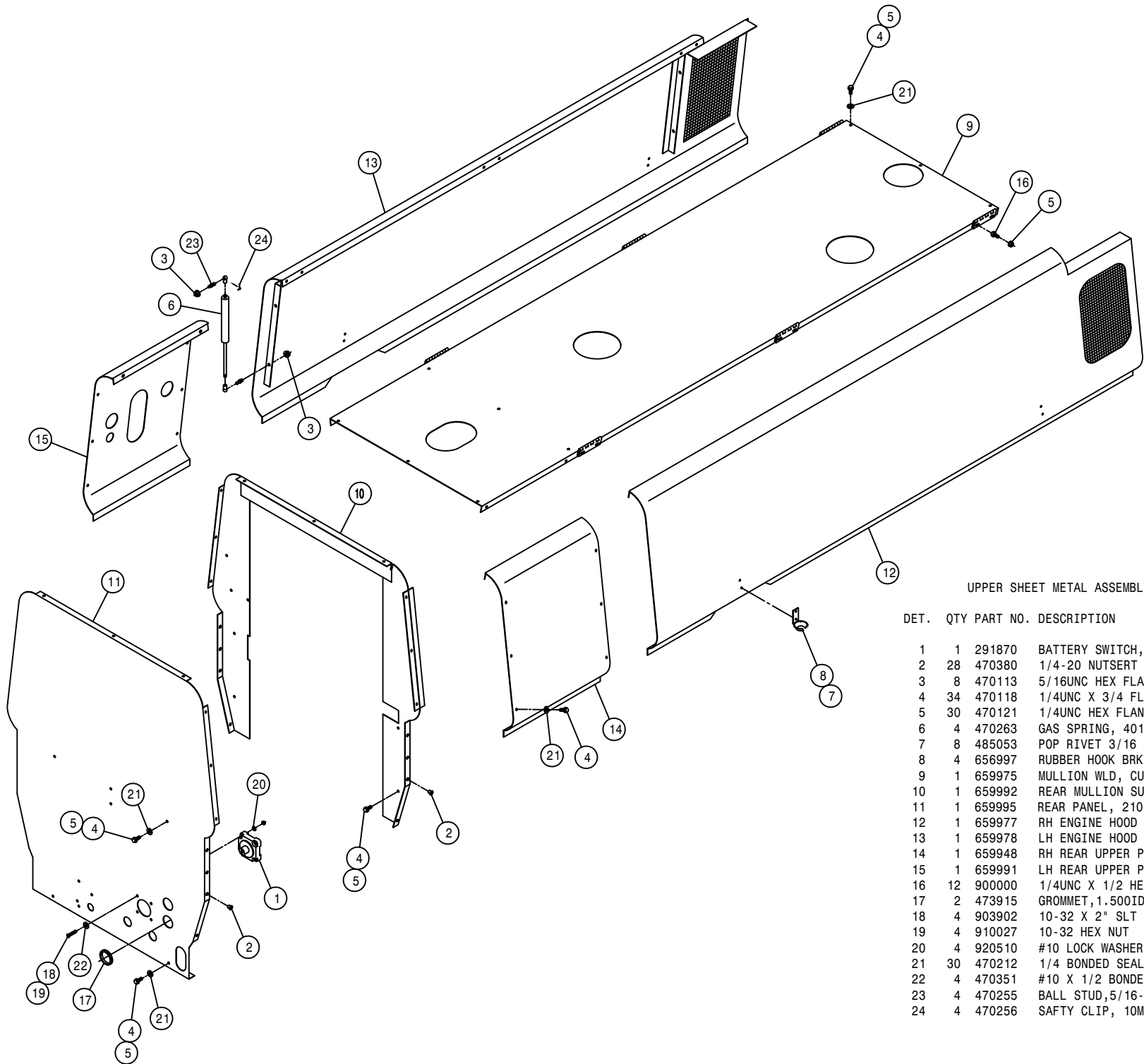

UPPER SHEET METAL ASSEMBLY

DET.	QTY	PART NO.	DESCRIPTION
	1	291870	BATTERY SWITCH, ON/OFF(KEY)
	28	470380	1/4-20 NUTSERT .027-.165 STL
	8	470113	5/16UNC HEX FLANGE LOCK NUT
	34	470118	1/4UNC X 3/4 FLANGE HEX NUT
	30	470121	1/4UNC HEX FLANGE LOCK NUT
	4	470263	GAS SPRING, 4016 8.00 STROKE
	7	485053	POP RIVET 3/16 X 3/8
	4	656997	RUBBER HOOK BRKT
	9	659975	MULLION WLD, CUMM, 2101 03
	10	659992	REAR MULLION SUPP WLD, 2101 03
	11	659995	REAR PANEL, 2101 03
	12	659977	RH ENGINE HOOD WLD, 2101 03
	13	659978	LH ENGINE HOOD WLD, 2101 03
	14	659948	RH REAR UPPER PANEL, 2100 98
	15	659991	LH REAR UPPER PANEL, 2101 03
	16	12	900000 1/4UNC X 1/2 HEX BOLT
	17	2	473915 GROMMET,1.500ID .062GW 1.750GD
	18	4	903902 10-32 X 2" SLT RD HD MACH SCR
	19	4	910027 10-32 HEX NUT
	20	4	920510 #10 LOCK WASHER
	21	30	470212 1/4 BONDED SEALING WASH, SS
	22	4	470351 #10 X 1/2 BONDED SEALING WASH
	23	4	470255 BALL STUD,5/16-18 THD X 10MM
	24	4	470256 SAFTY CLIP, 10MM BALL SOCKET

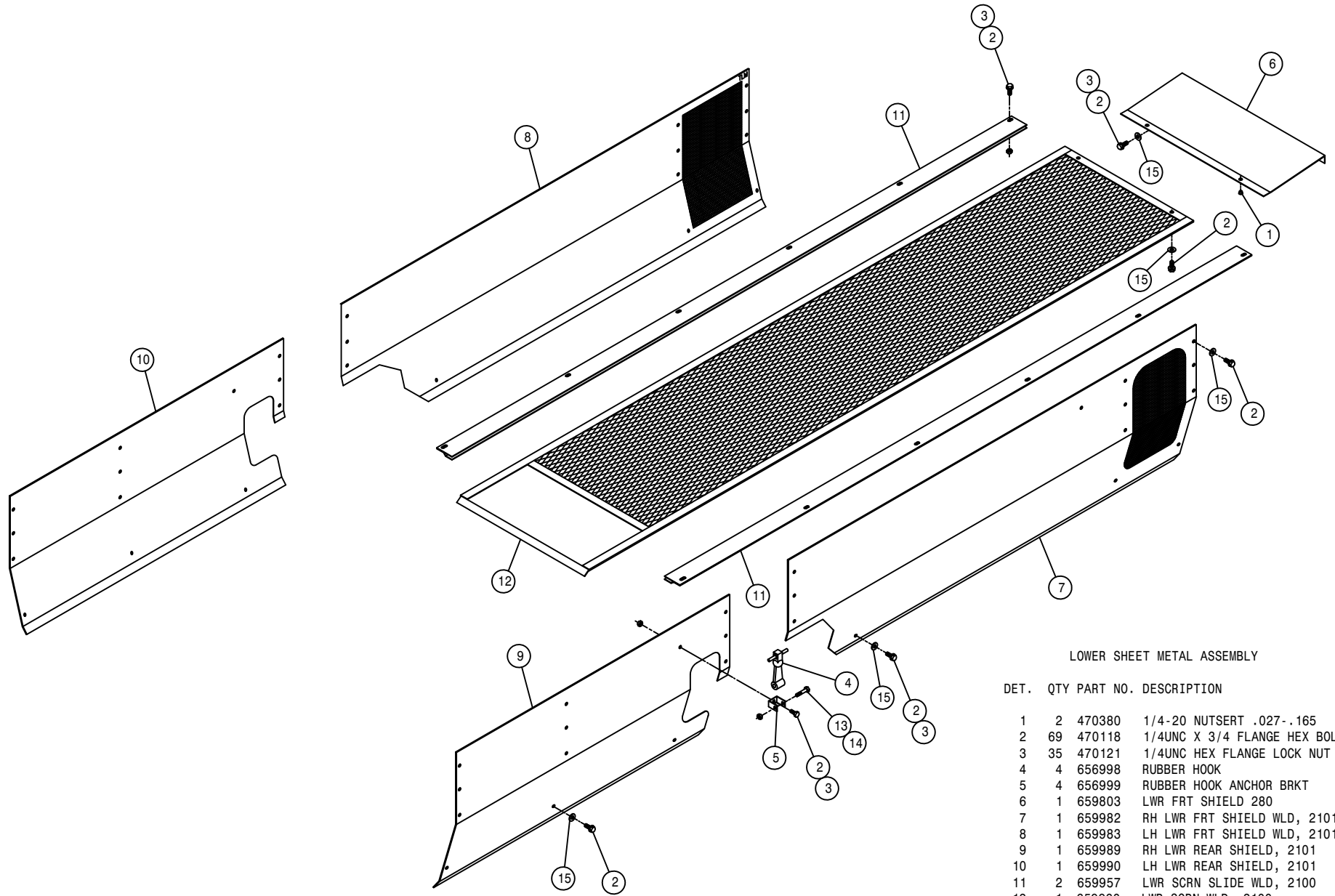

LOWER SHEET METAL ASSEMBLY

DET. QTY PART NO. DESCRIPTION

DET.	QTY	PART NO.	DESCRIPTION
1	2	470380	1/4-20 NUTSERT .027-.165 STL
2	69	470118	1/4UNC X 3/4 FLANGE HEX BOLT
3	35	470121	1/4UNC HEX FLANGE LOCK NUT
4	4	656998	RUBBER HOOK
5	4	656999	RUBBER HOOK ANCHOR BRKT
6	1	659803	LWR FRT SHIELD 280 89
7	1	659982	RH LWR FRT SHIELD WLD, 2101 03
8	1	659983	LH LWR FRT SHIELD WLD, 2101 03
9	1	659989	RH LWR REAR SHIELD, 2101 03
10	1	659990	LH LWR REAR SHIELD, 2101 03
11	2	659957	LWR SCR N SLIDE WLD, 2100 98
12	1	659960	LWR SCR N WLD, 2100 98
13	4	900005	1/4UNC X 1 1/2 HEX BOLT
14	4	914000	1/4UNC HEX STOVER NUT
15	53	470212	1/4 BONDED SEALING WASH, SS

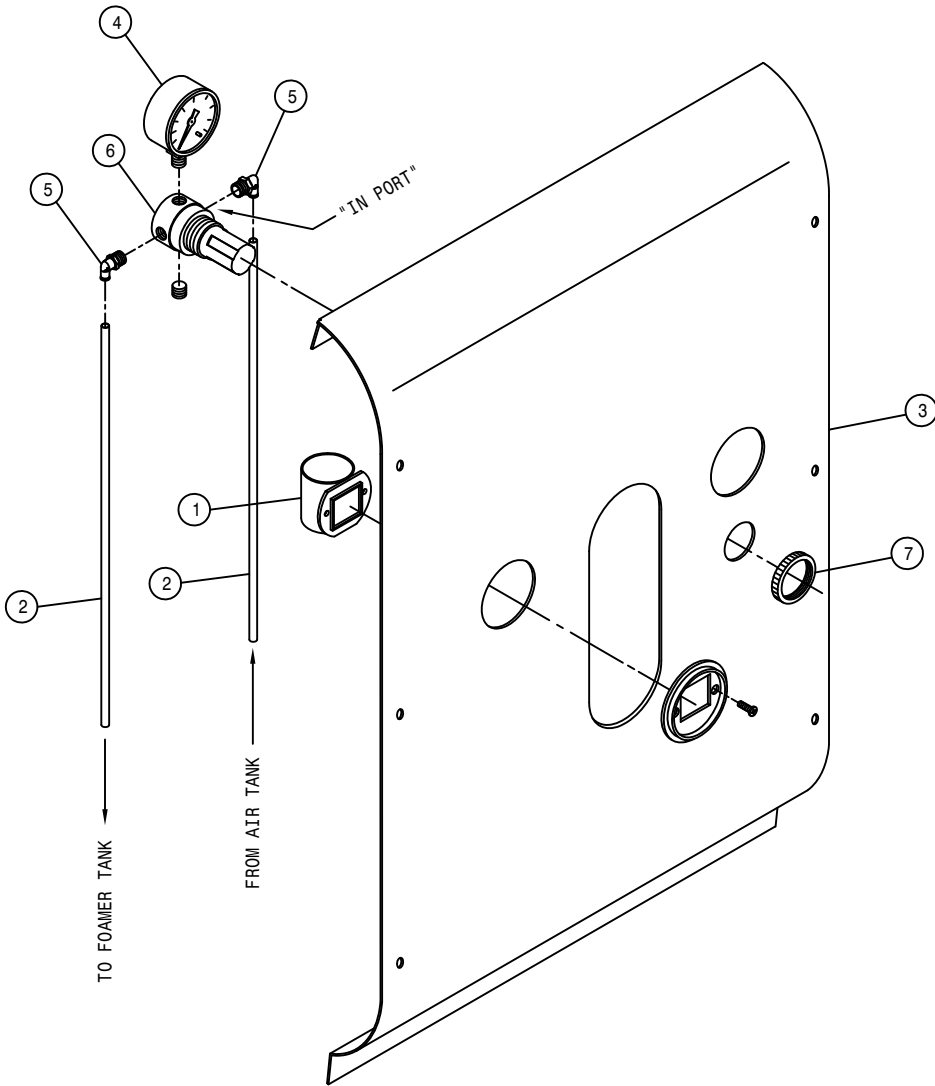

FOAMER AIR REGULATOR ASSEMBLY

DET. QTY PART NO. DESCRIPTION

1	1	314901	FILTER MINDER AIR RESTRICT GA
2	2	601592	HOSE, 1/4 X 72 AIR
3	1	659991	LH REAR UPPER PANEL, 2101 03
4	1	701310	AIR PRESS GAUGE, 1/8"BOT
5	2	711040	1/4MNPT-90-1/4 NYL TUBE LBO
6	1	711019	1/4"MNPT AIR REGULATOR
7	1	711021	1 1/4-18 NUT,AIR REGULATOR MT

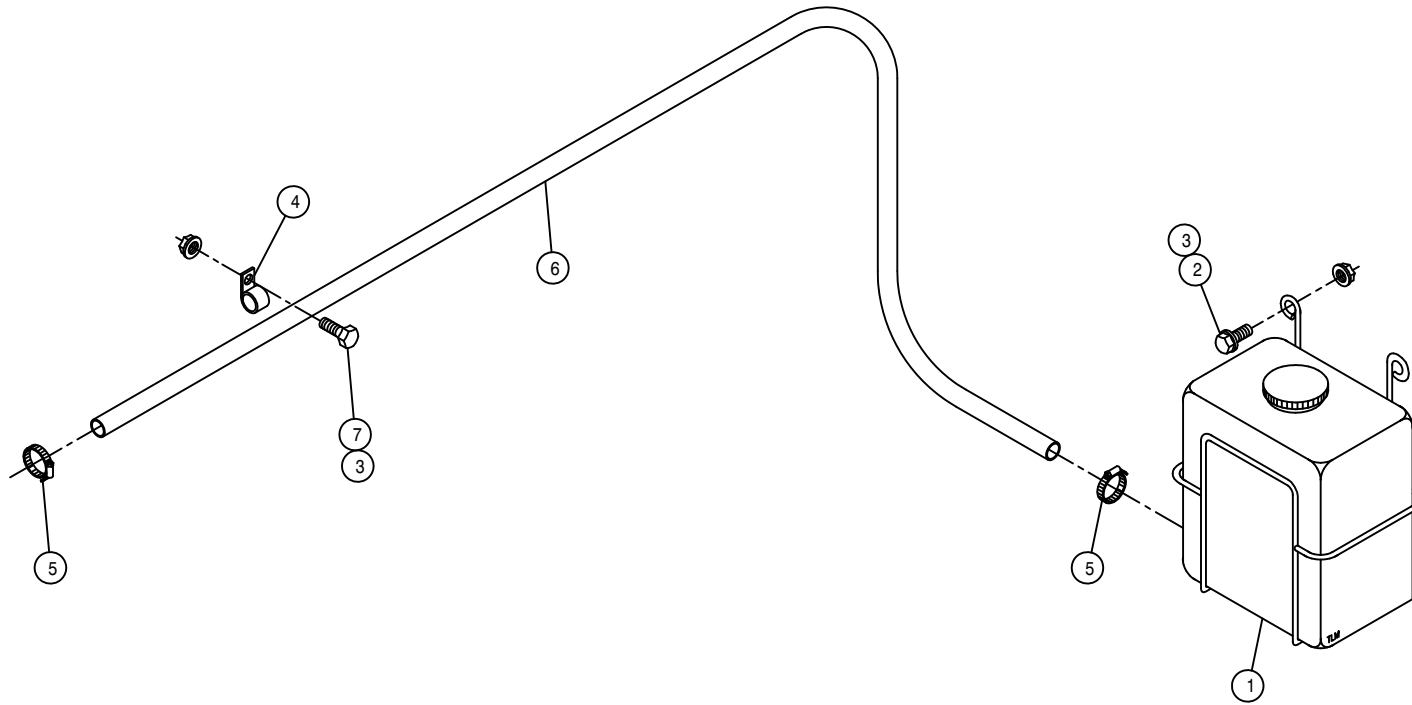

RADIATOR RECOVERY TANK ASSEMBLY

DET.	QTY	PART NO.	DESCRIPTION
1	1	314767	RAD RECOVERY TANK & MTG WLD
2	3	470118	1/4UNC X 3/4 FLANGE HEX BOLT
3	7	470121	1/4UNC HEX FLANGE LOCK NUT
4	4	520117	CUSH HOSE CLAMP 5/8D X 1/2W
5	2	520120	HOSE CLAMP NO 4 STAINLESS
6	1	601424	HOSE, 5/16 X 114 EPDM
7	4	900002	1/4UNC X 3/4 HEX BOLT

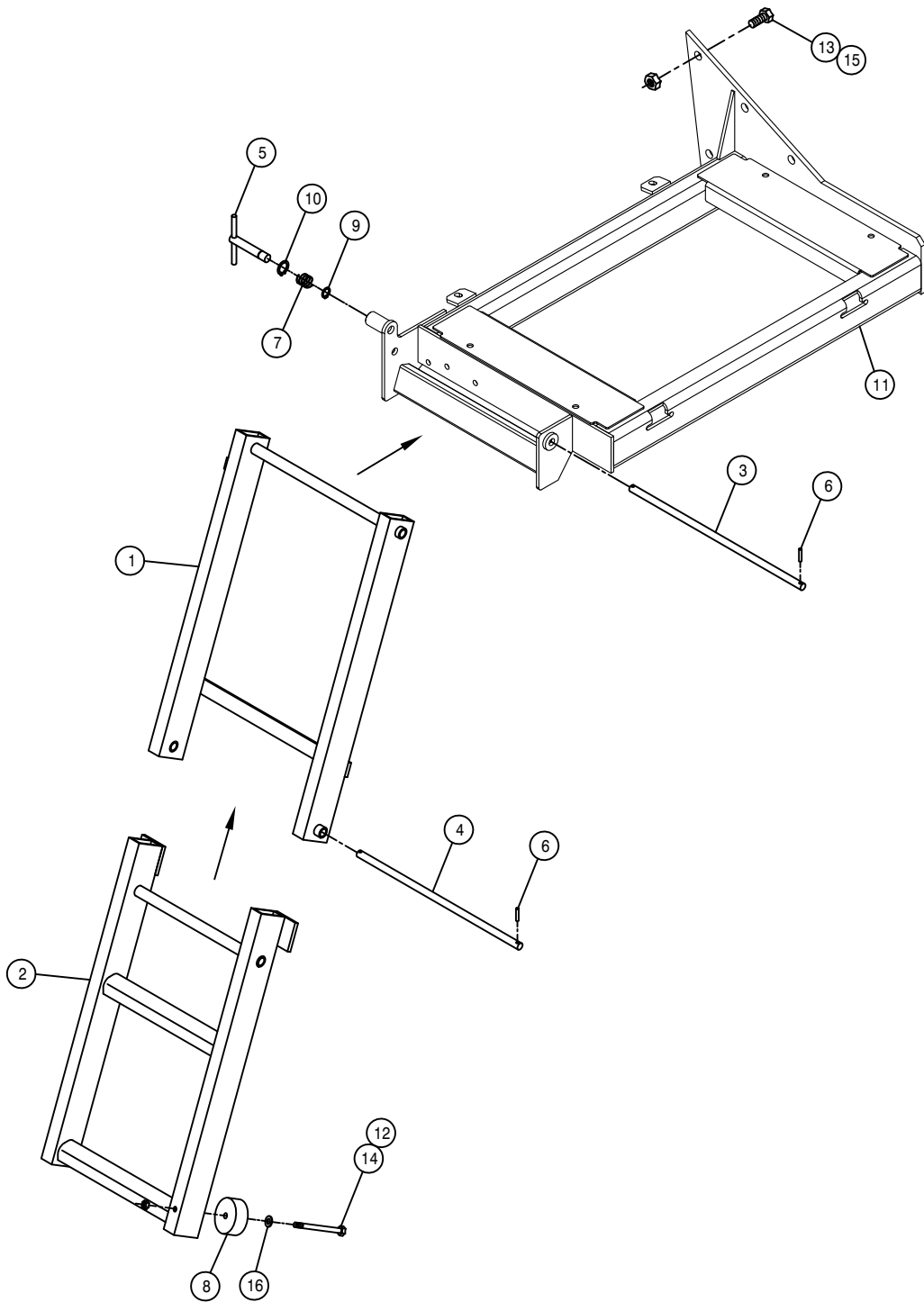

RIGHT FOLDING LADDER ASSEMBLY

DET.	QTY	PART NO.	DESCRIPTION
	1	342583	FOLD LDDR UPR SECT WLD,2100 98
	2	342589	FOLD LDDR LWR SECT WLD,2100 98
	3	342594	FOLD LADDER UPR PIVOT PIN 98
	4	342595	FOLD LADDER LWR PIVOT PIN 98
	5	342596	FOLD LDDR LOCK PIN WLD,2100 98
	6	473928	ROLL PIN, 3/16 X 1
	7	482131	3/4 X 1 3/4 COMPRSN SPRING
	8	470098	RUBBER BUMPER 2.500D X .38ID
	9	629534	SNAP RING, 9/16 EXTERNAL
	10	629535	SNAP RING, 3/4 INTERNAL
	11	760278	RH FUEL TANK MT WLD, 2101 03
	12	900072	5/16UNC X 3" HEX BOLT
	13	900334	5/8UNC X 1 3/4 HEX BOLT
	14	910002	5/16UNC HEX NUT
	15	914010	5/8UNC HEX STOVER NUT
	16	920001	5/16 SAE FLAT WASHER

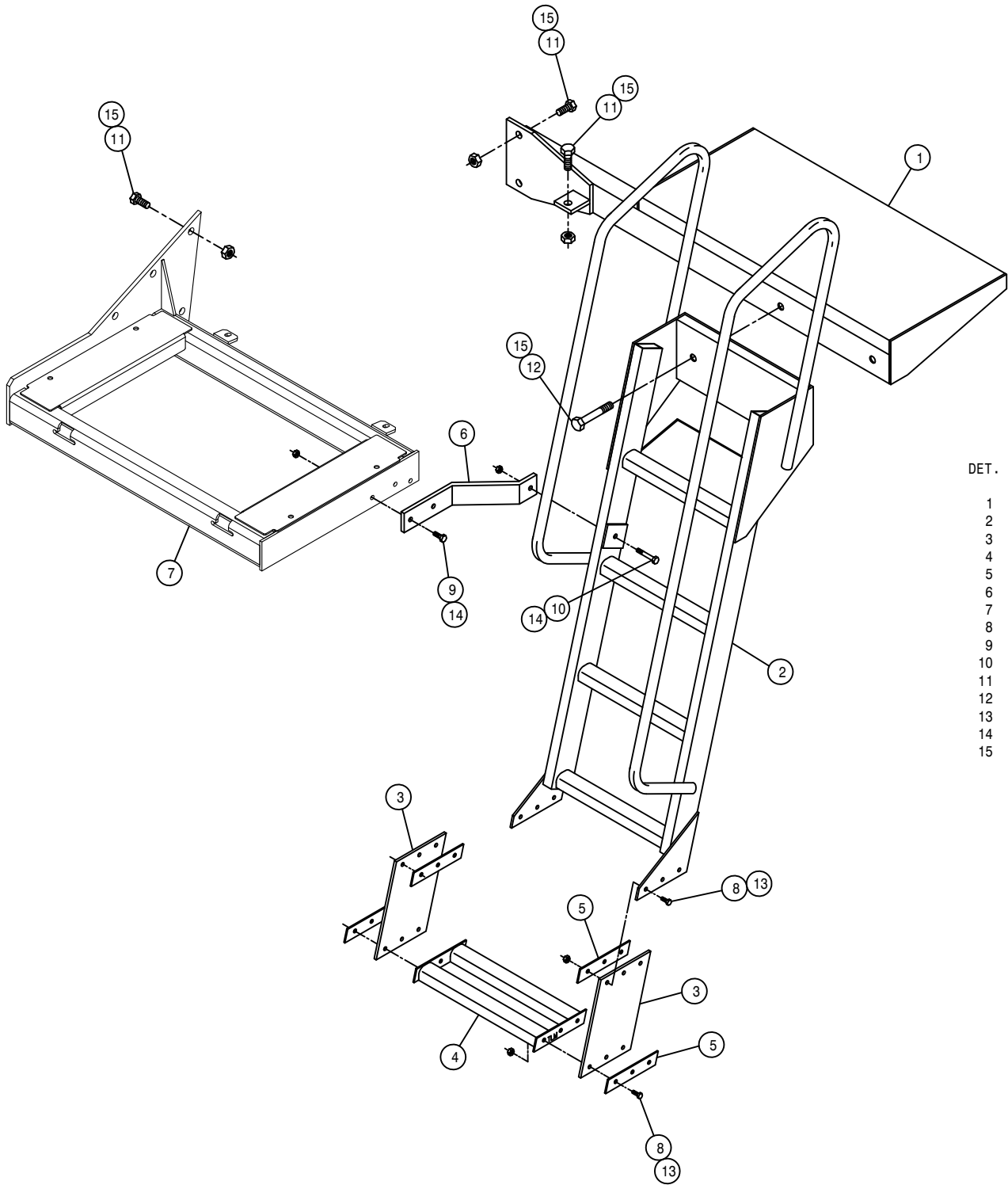

LEFT LADDER ASSEMBLY

DET.	QTY	PART NO.	DESCRIPTION	
	1	342599	LH LADDER MT WLD, 2100	98
	1	342605	LH LADDER WLD, 2100	98
	2	342614	LADDER SIDE, LWR STEP, 2100	98
	1	342615	LADDER STEP WLD, 2100	98
	4	342616	LWR STEP SIDE KEEPER, 2100	98
	1	342618	LH LADDER SUPP BRKT, 2100	98
	1	760279	LH FUEL TANK MT WLD, 2101	03
	12	900065	5/16UNC X 1" HEX BOLT	
	2	900130	3/8UNC X 1 1/4 HEX BOLT	
	1	900133	3/8UNC X 2" HEX BOLT	
	9	900334	5/8UNC X 1 3/4 HEX BOLT	
	2	900829	5/8UNC X 4" HEX BOLT GR8	
	12	914002	5/16UNC HEX STOVER NUT	
	3	914004	3/8UNC HEX STOVER NUT	
	11	914010	5/8UNC HEX STOVER NUT	

NEW TANK REPLACEMENT KIT-KSP007

FUEL TANK ASSEMBLY

DET.	QTY	PART NO.	DESCRIPTION
1	2	291428	FUEL SENDER 19 IN.
2	10	473902	#8 X 1/2 PHIL PAN HD MTL SCR
3	2	501102	1/4 PIPE PLUG
4	4	501451	BLK PIPE EL 90DEG .25NPT
5	4	501602	BLK PIPE NIPPLE .25NPT-1.50
6	2	760907	FUEL TANK WLD - DTS
7	4	505213	RED BUSH 1 X 3/4 BLK MAL
8	2	783303	1/4 NPT X 5/16 HOSE BARB, BRS
9	2	783304	1/4 NPT X 3/8 HOSE BARB, BRS
10	4	760895	FUEL SUCTION DROP TUBE, 204
11	8	470087	3/8UNC HEX SER FLG NUT
12	14	520120	HOSE CLAMP NO 4 STAINLESS
13	1	601290	HOSE, 5/16 X 20 FUEL LINE
14	1	601546	HOSE, 3/8 X 108 FUEL LINE
15	2	291464	GSKT FUEL SENDER, FOR291428
16	2	601545	HOSE, 5/16 X 108 FUEL LINE
17	1	601355	HOSE, 3/8 X 100 FUEL LINE
18	1	601322	HOSE, 3/8 X 26 FUEL LINE
19	1	610529	FUEL SELECTOR VALVE W/RETURN
20	4	470121	1/4UNC SER FLG LOCK NUT
21	2	900064	5/16UNC X 3/4 HEX BOLT
22	2	760469	FUEL TANK CAP, 3.50" VENTED
23	4	470409	3/8UNC X 3/4 SER FLG BOLT
24	4	900128	3/8UNC X 3/4 HEX BOLT YZ
25	2	601622	HOSE, 3/8 X 12 FUEL LINE
26	2	316281	FUEL STRAINER, IN-LINE, DIESEL

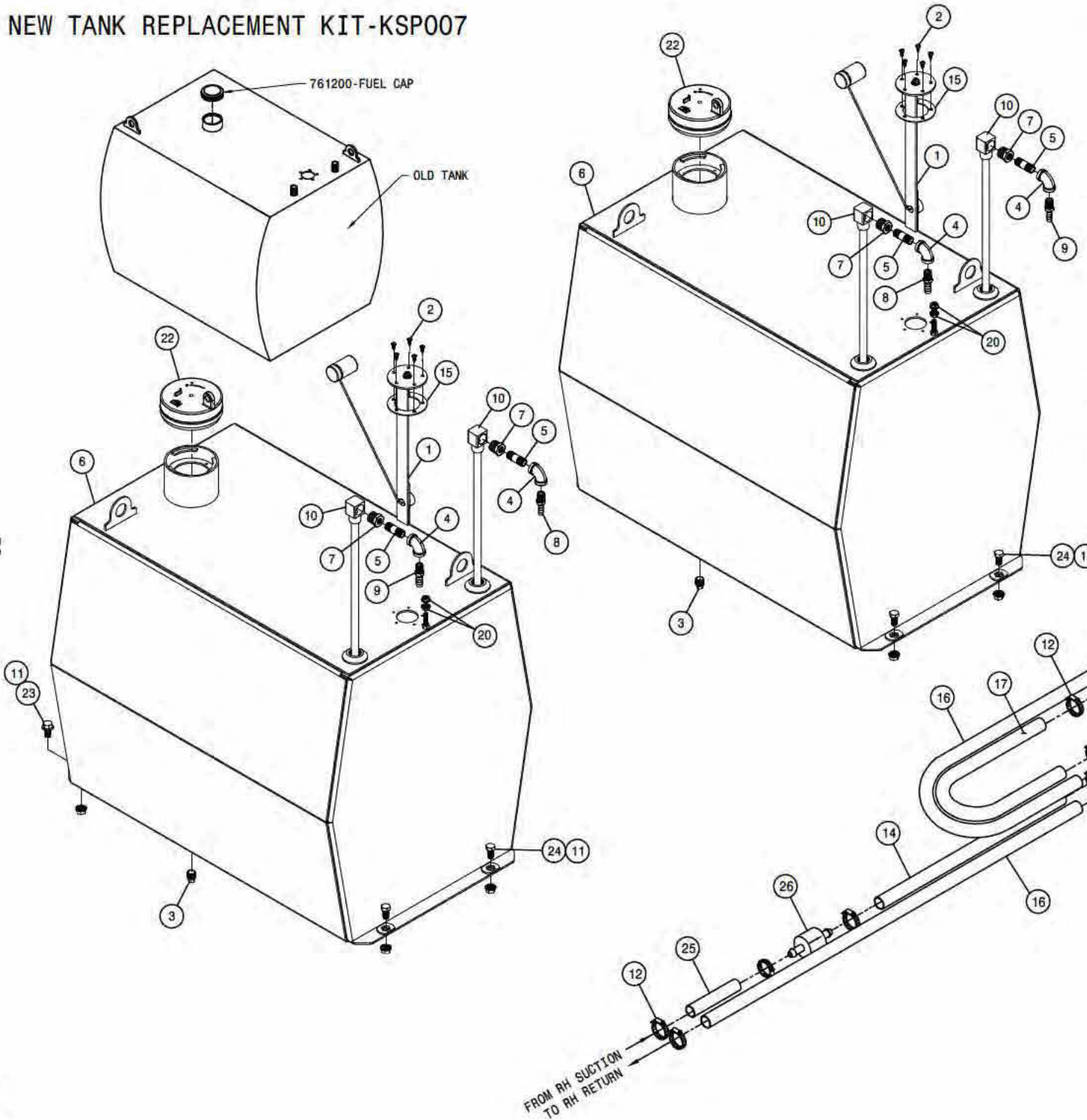

SERVICE PLATFORM ASSEMBLY

DET. QTY PART NO. DESCRIPTION

1	2	293403	TAIL/TURN LIGHT ASSY, 2100	98
2	2	341900	SERVICE PLATFORM MT KPR	90
3	1	342538	RH SERVICE PLATFORM WLD2100	98
4	1	342539	LH SERVICE PLATFORM WLD2100	98
5	1	343221	REAR SERV PLATFORM WLD,2100	03
6	2	342565	CNTR SERV PLTFRM MT PLT2100	98
7	1	342566	RH UPPER SIDE RAIL TUBE WLD	98
8	1	342567	LH UPPER SIDE RAIL TUBE WLD	98
9	1	342576	REAR HANDRAIL WLD, 2100	98
10	1	342628	RH TREAD ADJ GAUGE MT	98
11	1	342629	LH TREAD ADJ GAUGE MT	98
12	1	342641	REAR HANDRAIL EXT WLD, 2100	98
13	1	342645	STEP EXT WLD, 2100	98
14	1	342650	RH REAR TRD IND WLD, 2100	98
15	1	342651	LH REAR TRD IND WLD, 2100	98
16	4	470118	1/4UNC X 3/4 FLANGE HEX BOLT	
17	4	470121	1/4UNC HEX FLANGE LOCK NUT	
18	1	472251	MTG SOCKET FOR 472249 SMV SIGN	
19	1	656886	SLO MOVING VEHICLE SIGN ASSY	
20	1	659852	SMV SIGN MTG BRKT 8200	89
21	1	900005	1/4UNC X 1 1/2 HEX BOLT	
22	4	900068	5/16UNC X 1 3/4 HEX BOLT	
23	10	900065	5/16UNC X 1" HEX BOLT	
24	24	900129	3/8UNC X 1" HEX BOLT	
25	8	900266	1/2UNC X 1 3/4 HEX BOLT	
26	1	914000	1/4UNC HEX STOVER NUT	
27	14	914002	5/16UNC HEX STOVER NUT	
28	12	914008	1/2UNC HEX STOVER NUT	
29	24	914004	3/8UNC HEX STOVER NUT	
30	1	164364	RH LIFTARM V-PLT MT WLD2100	98
31	1	164365	LH LIFTARM V-PLT MT WLD2100	98
32	4	900265	1/2UNC X 1 1/2 HEX BOLT	
33	8	920004	1/2 SAE FLAT WASHER	
34	10	920001	5/16 SAE FLAT WASHER	

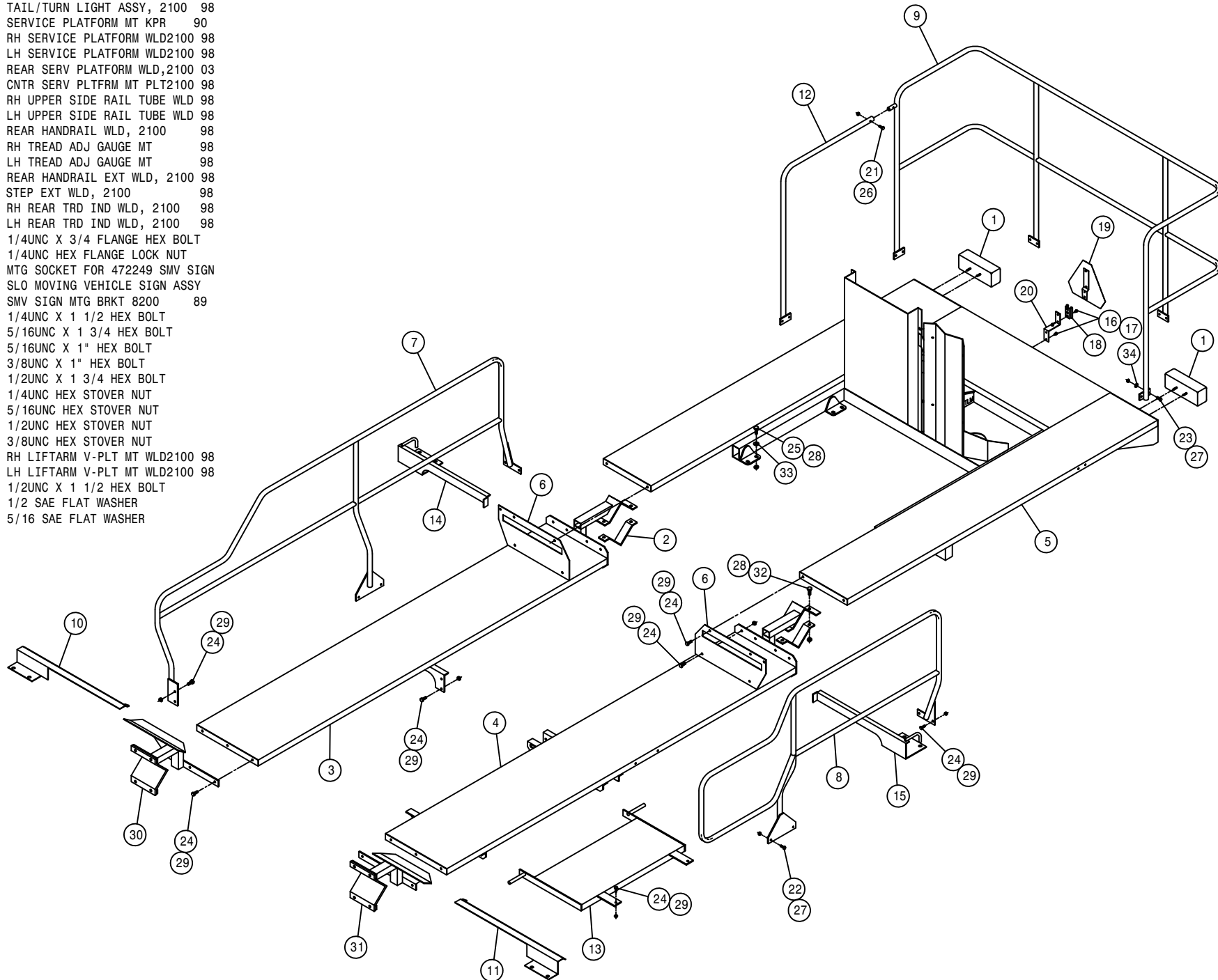

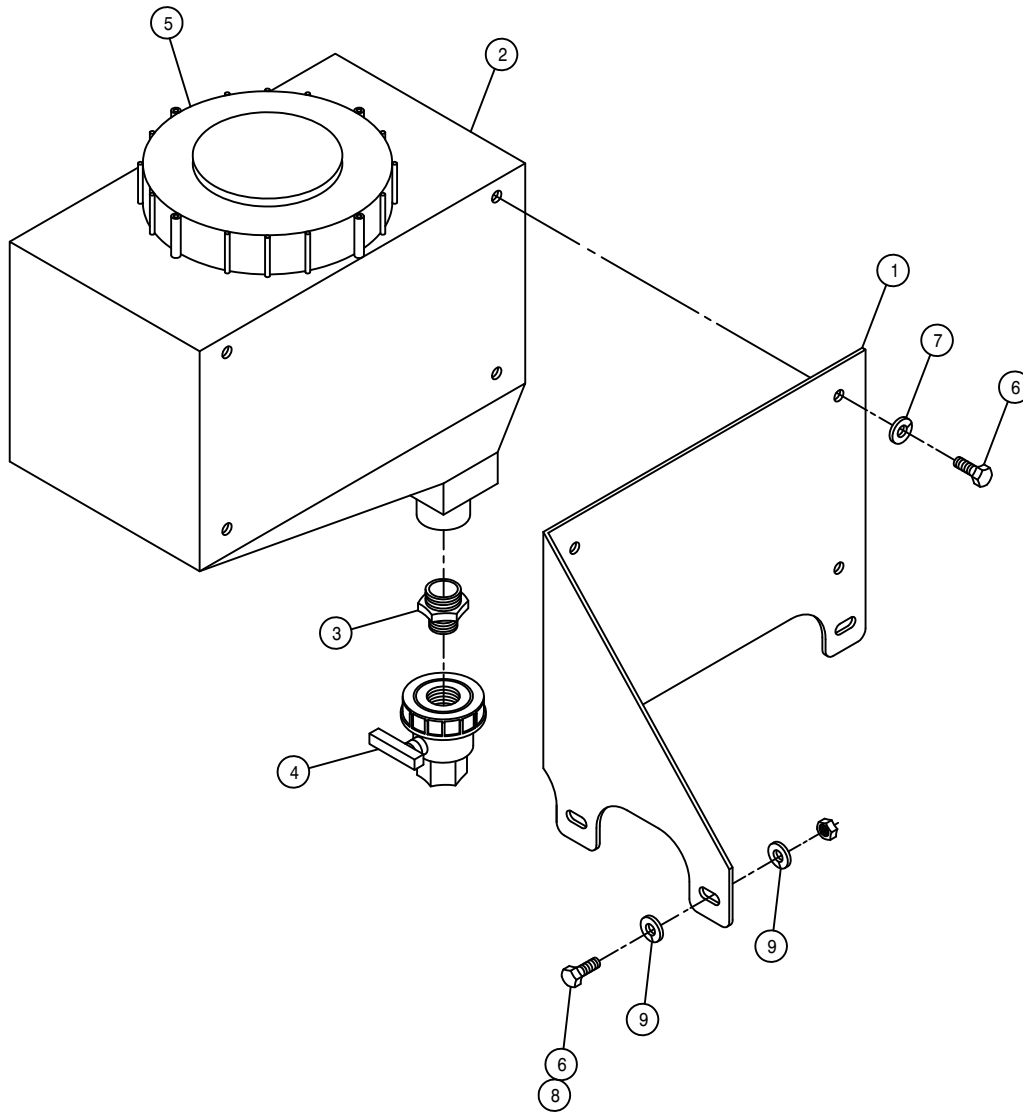

FRESH WATER TANK ASSEMBLY

DET. QTY PART NO. DESCRIPTION

1	1	343264	FRESH WATER TANK MT, 2101 04
2	1	470318	RINSE TANK, 3 GAL SQ SAFETY
3	1	500124	3/4 X 1/2NPT REDU NIPPLE,POLY
4	1	696005	BALL VLV, .500NPT, 100PSI, POLY
5	1	470337	6" LID FOR 3 GAL TANK 470318
6	7	900064	5/16UNC X 3/4 HEX BOLT
7	4	920501	5/16 LOCK WASHER
8	3	914002	5/16UNC HEX STOVER NUT
9	6	920001	5/16 SAE FLAT WASHER

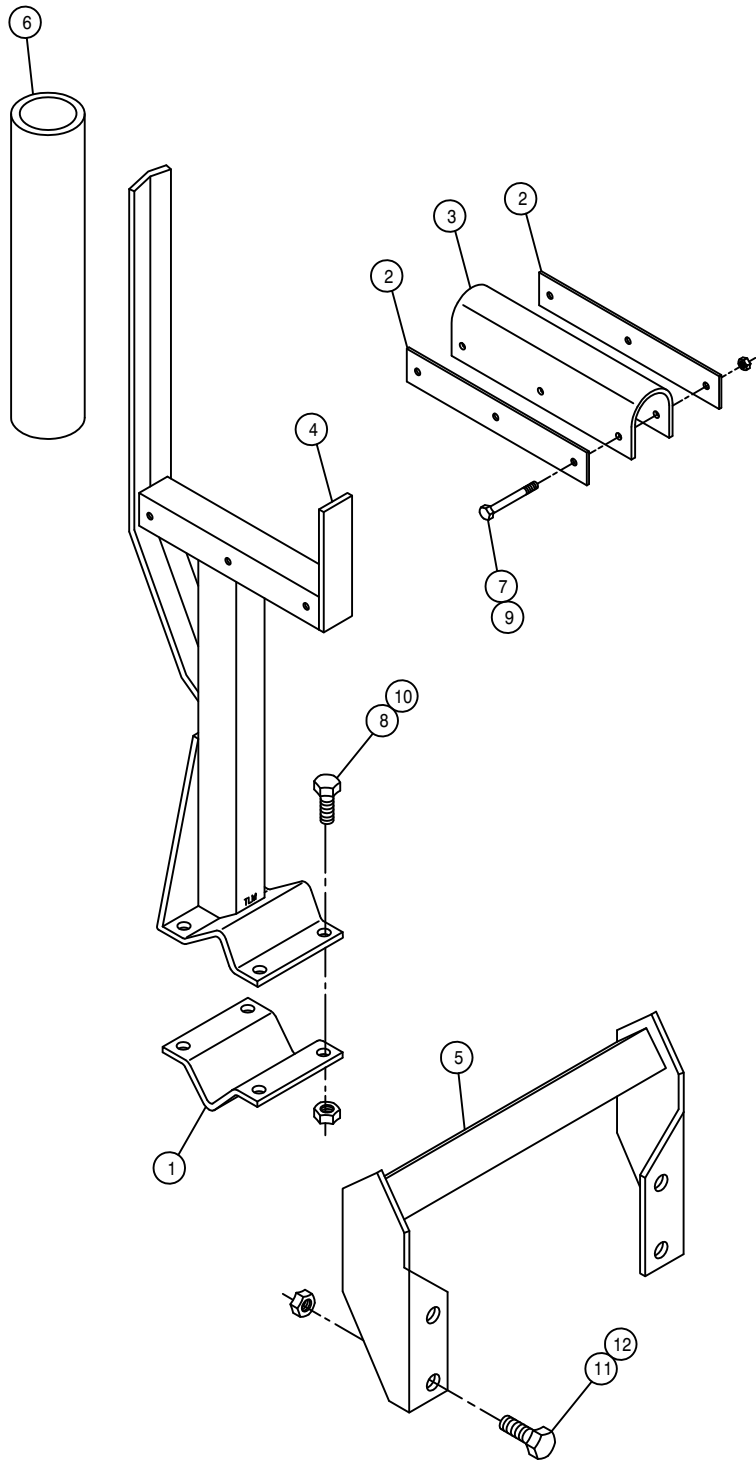

BOOM CRADLE ASSEMBLY

DET. QTY PART NO. DESCRIPTION

1	2	164253	BOOM CRADLE V-PLATE KEEPER	96
2	4	164254	CRADLE CUSHION KEEPER	96
3	2	164256	BOOM CRADLE CUSHION	96
4	2	164372	BOOM CRADLE WLD, 2100	98
5	2	164376	BOOM CRADLE MT WLD, 2100	98
6	2	601184	HOSE, 1 1/2 X 14 2BR BLK EPDM	
7	6	900008	1/4UNC X 2 1/2 HEX BOLT	
8	8	900265	1/2UNC X 1 1/2 HEX BOLT	
9	6	914000	1/4UNC HEX STOVER NUT	
10	8	914008	1/2UNC HEX STOVER NUT	
11	8	900334	5/8UNC X 1 3/4 HEX BOLT	
12	8	914010	5/8UNC HEX STOVER NUT	

NOTE: QUANTITY LISTED IS FOR ONE MACHINE.

BATTERY BOX ASSEMBLY

DET. QTY PART NO. DESCRIPTION

1	1	291300	BATTERY, 12V 1000CCA, STUD 31-5T
2	2	291205	BATTERY NUT, 3/8-16 SS CLSD CAP
3	1	291860	BATT CABLE, RED 50" 4GA. 343-.406
4	1	291862	BATT CABLE, BLK 50" 1/0. 406-.406
5	1	291865	BATT CABLE, RED 74" 1/0. 406-.406
6	1	291863	BATT CABLE, BLK 72" 1/0. 406-.406
7	1	291864	BATT CABLE, RED 16" 1/0. 406-.406
8	1	291680	POSITIVE JUMPER STUD, RED
9	1	291681	NEGATIVE JUMPER STUD, BLACK
10	1	341322	BATTERY HOLD DOWN WLD 1981
11	1	361470	BATTERY BOX WLD, 2100 98
12	1	900339	5/8UNC X 3 1/4 HEX BOLT
13	2	901150	3/8UNC X 9" CARR BOLT
14	1	900129	3/8UNC X 1" HEX BOLT
15	3	914004	3/8UNC HEX STOVER NUT
16	1	914010	5/8UNC HEX STOVER NUT

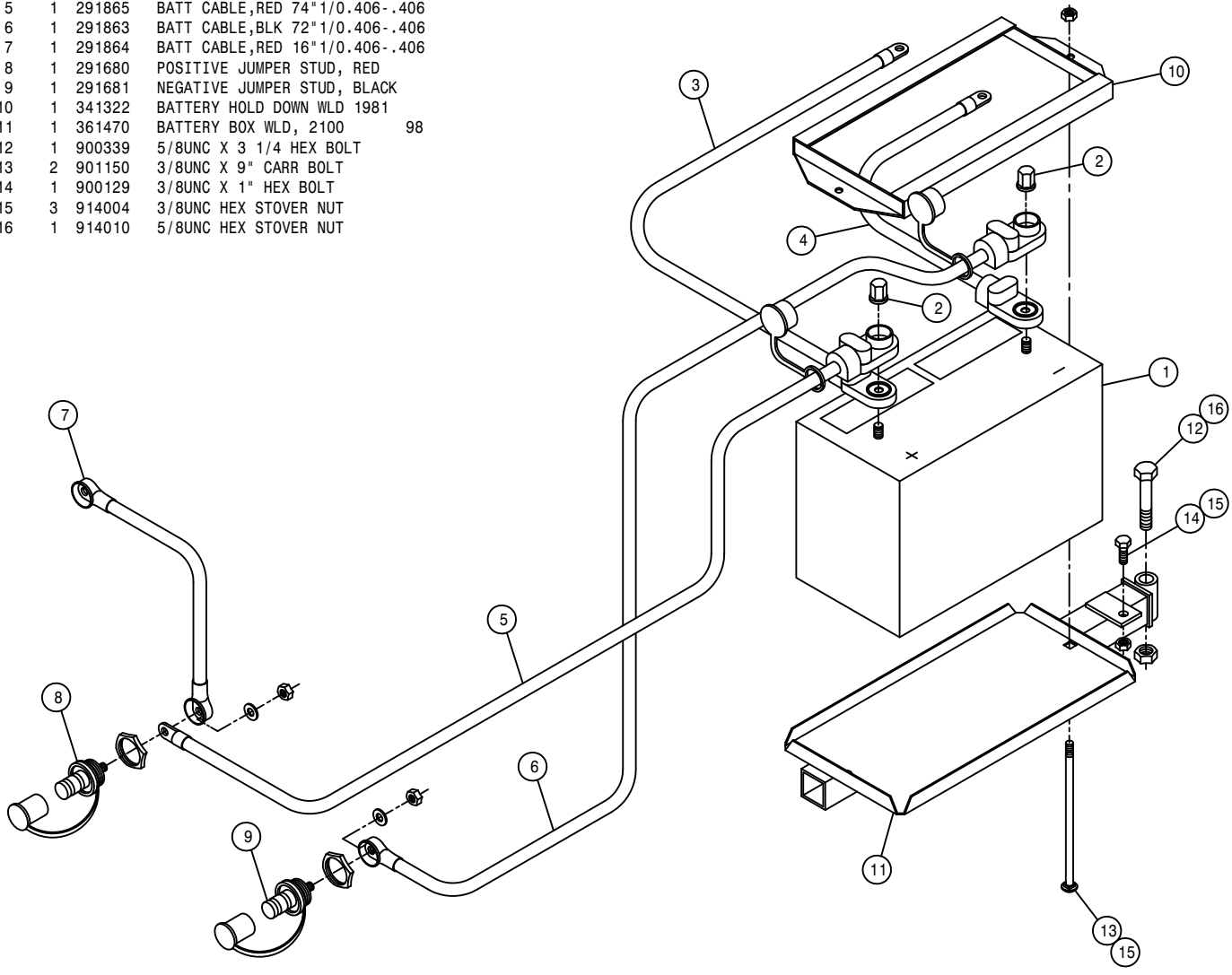

SOLUTION TANK MOUNTS AND SHIELDS

DET. QTY PART NO. DESCRIPTION

DET.	QTY	PART NO.	DESCRIPTION	
1	2	193016	QUICKEDGE TRIM .060 TO .170	
2	2	293402	HEADLIGHT ASSY, 2100	98
3	2	358958	LEG BRACE WLD, 2100	99
4	2	470100	3/8 INT TOOTH LOCK WASHER	
5	26	470118	1/4UNC X 3/4 FLANGE HEX BOLT	
6	30	470121	1/4UNC HEX FLANGE LOCK NUT	
7	2	473779	10MM-1.50 HEX NUT	
8	2	473971	1/4UNC-2" ID-3" RD U-BOLT	
9	1	659831	LWR FRONT SHIELD 280	89
10	1	659963	RH FRT TANK SHLD WLD 2100	98
11	1	659964	LH FRT TANK SHLD WLD 2100	98
12	2	659968	HEADLIGHT MT WLD, 2100	98
13	1	763476	RH FRT SOLU TNK MT WLD, 2100	98
14	1	763477	LH FRT SOLU TNK MT WLD, 2100	98
15	1	763478	RH REAR SOLU TNK MT WLD 2100	98
16	1	763479	LH REAR SOLU TNK MT WLD 2100	98
17	4	763490	SOLU TANK MT SUPP, 2100	98
18	12	900334	5/8UNC X 1 3/4 HEX BOLT	
19	8	900412	3/4UNC X 5" HEX BOLT	
20	2	910017	1" UNC HEX NUT	
21	12	914010	5/8UNC HEX STOVER NUT	
22	10	914012	3/4UNC HEX STOVER NUT	
23	4	920008	1" SAE FLAT WASHER	
24	2	920508	1" LOCK WASHER	
25	2	358961	LEG BRACE CLEVIS WLD, 2100	99
26	2	900410	3/4UNC X 4" HEX BOLT	
27	2	900814	1" UNC X 4" HEX BOLT	GR8
28	22	470212	1/4 BONDED SEALING WASH, SS	

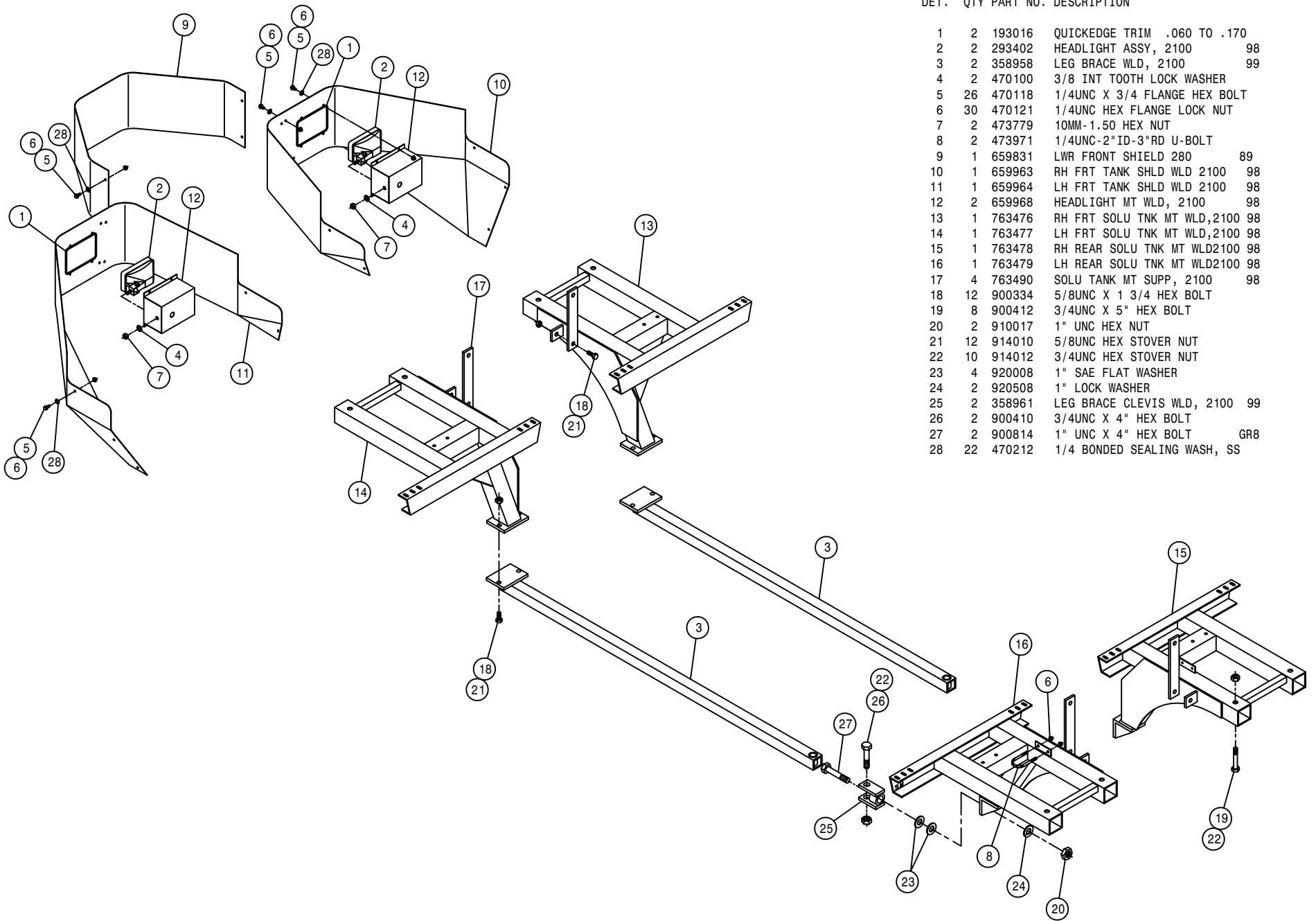

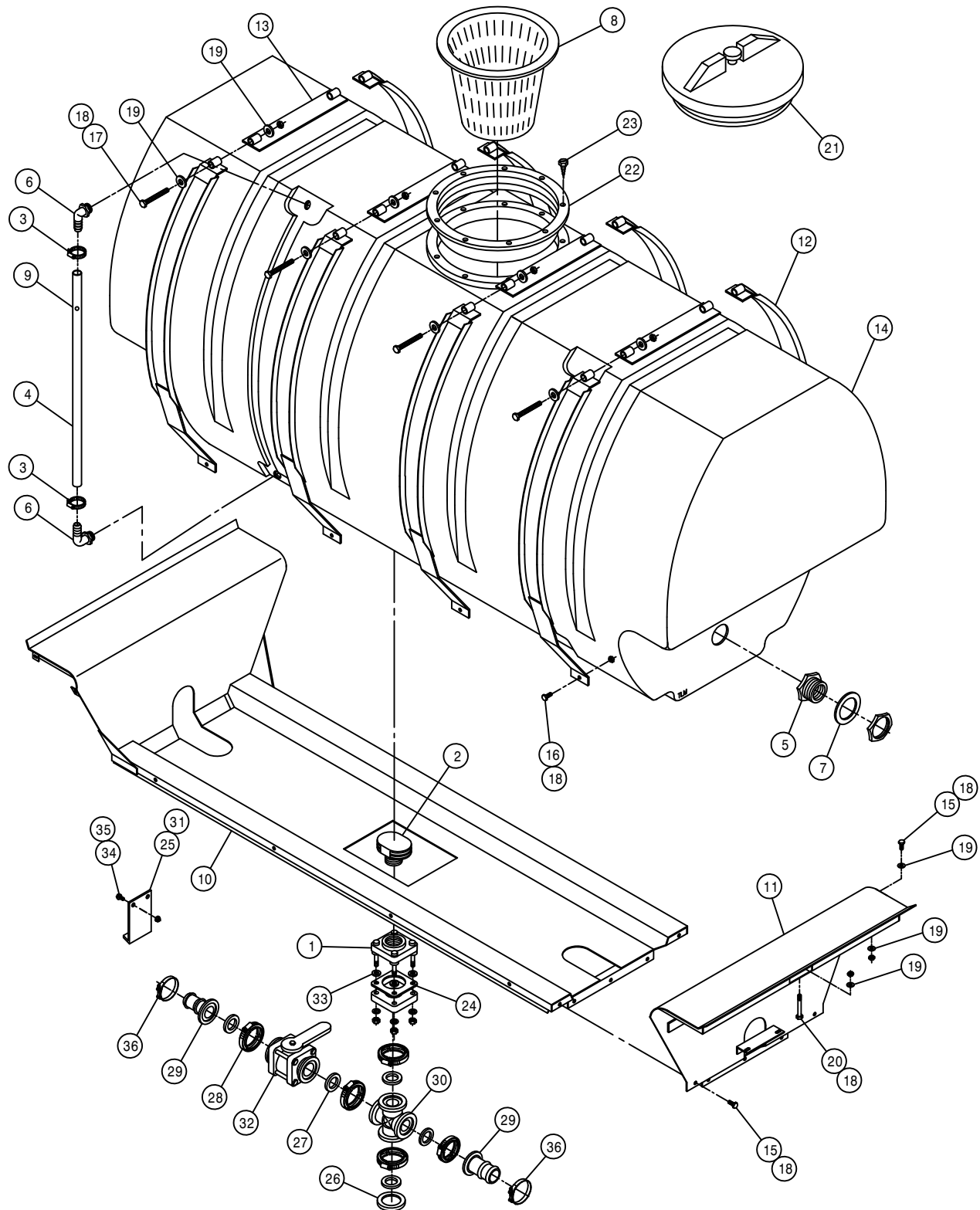

RIGHT POLY SOLUTION TANK ASSEMBLY

DET.	QTY	PART NO.	DESCRIPTION
	1	500179	2"FLG TANK FTG,BOTDRN BLT POLY
	1	500077	VENT CAP, 2" W/O SCREEN,POLY
	2	520069	HOSE CLAMP NO 6 STAINLESS
	1	601245	HOSE, 1/2 X 42 CLEAR VINYL
	2	618548	1.25 PLASTIC FTG ASSY POLYTNK
	2	618556	1/4NPT-90-1/2 HOSE BARB,POLY
	2	763430	1 1/4 TANK FLANGE RUBBER SEAL
	1	763431	8" STRAINER BASKET, SOLU TANK
	1	763446	RED POLYPROPYLENE BALL 25/64"
	1	763652	POLY TANK CRADLE WLD, 2101 04
	1	763502	REAR CRADLE MT WLD, 2100 98
	8	763507	TANK BAND WLD, 2100 POLY 98
	4	763511	TANK BAND TIE WLD, 2100 98
	1	763513	500 GAL POLY SOLU TANK 98
	13	900129	3/8UNC X 1" HEX BOLT
	8	900130	3/8UNC X 1 1/4 HEX BOLT
	17	906138	3/8UNC X 3 1/2 HEX BOLT FULL
	33	914004	3/8UNC HEX STOVER NUT
	36	920002	3/8 SAE FLAT WASHER
	4	900140	3/8UNC X 4" HEX BOLT
	1	763408	LID, THD'D W/VENT, POLY TANK
	1	763409	10" THD'D RING FOR TANK LID
	8	763410	S.S. SCREW FOR CAP RING
	1	500087	GASKET,2" TANK FLG 500076/179
	1	763363	SOLU HOSE SUPPORT 280 POLY 91
	1	500156	2" FLANGE CAP PLUG POLY
	5	500158	1 1/2" GASKET FOR 2" FLANGE
	5	500160	2" FLANGE CLAMP, S.S.
	2	500162	2" FLANGE-1 1/2 HOSE BARB POLY
	1	500176	2" FLANGE CROSS POLY
	1	470000	CABLE TIE, 21" BLACK PLASTIC
	1	696142	BALL VLV, 2" FLANGE
	4	500100	FOOT GASKET,2" FLG 500076/179
	2	470118	1/4UNC X 3/4 FLANGE HEX BOLT
	2	470121	1/4UNC HEX FLANGE LOCK NUT
	2	520133	1.81/2.06 T-BOLT HOSE CLAMP SS

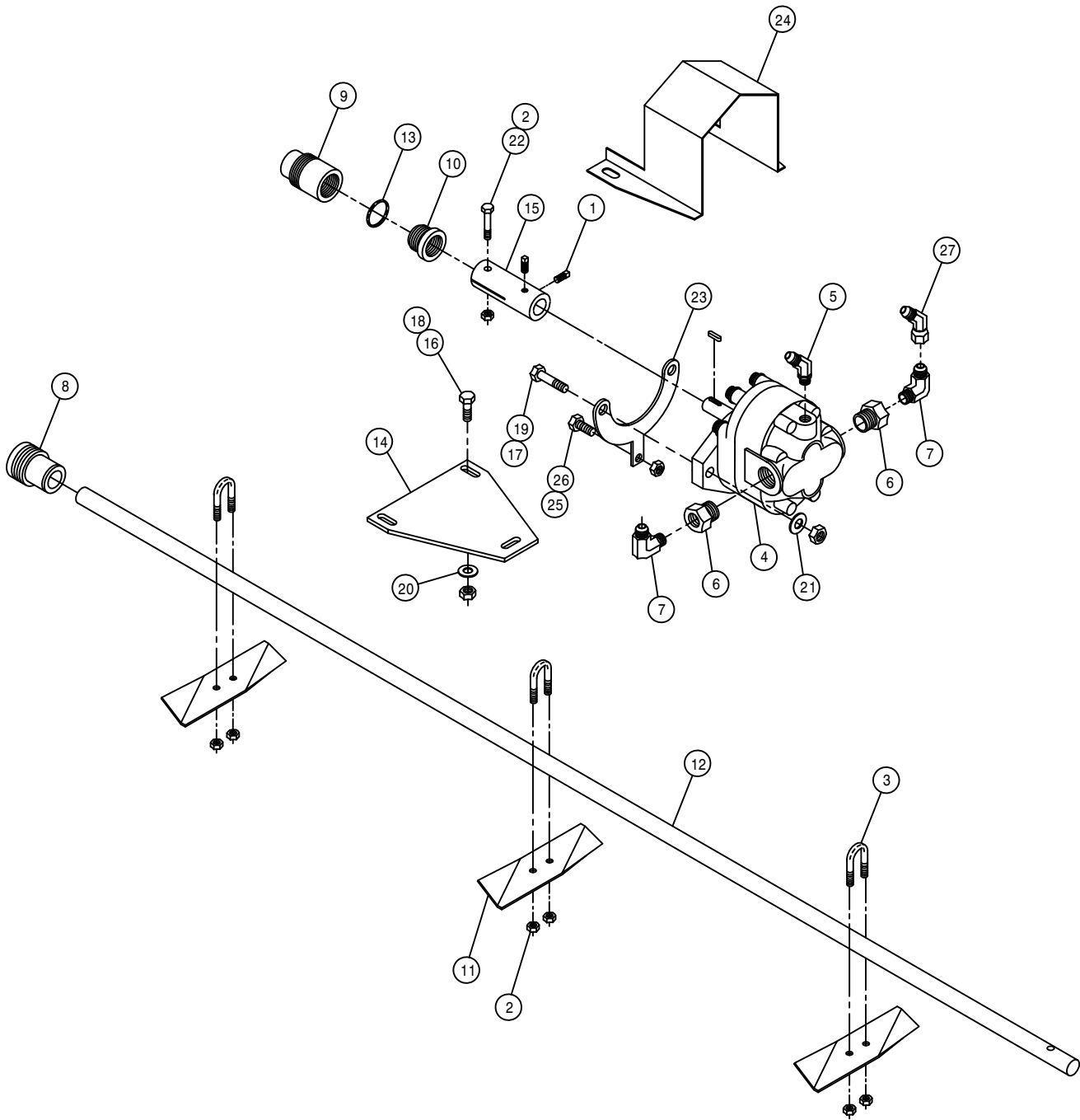

RH POLY TANK AGITATOR ASSEMBLY

DET. QTY PART NO. DESCRIPTION

1	2	470199	1/4UNC X 3/8 SQHD CUP SET SCR	
2	7	470089	1/4UNC HEX LOC NUT NYL INS SS	
3	3	470092	1/4UNC-3/4ID-1 1/4 U-BOLT SS	
4	1	610510	CESSNA GEAR MOTOR 1.48CI	
5	1	618338	9/16MJIC-45-1/4MNPT LBO	
6	2	618092	1 1/16MOR-1/2FNPT ADPTR	
7	2	618107	9/16MJIC-90-1/2MNPT LBO	
8	1	706403	FRT AGIT SHFT BRG, NYLON	
9	1	706401	REAR AGIT SHFT BRG, NYLON	
10	1	706402	AGIT SHFT GLAND NUT, NYLON	
11	3	763027	AGIT IMPELLER	
12	1	763514	AGIT SHAFT, 2100	98
13	1	763217	GLAND PACKING, 13 IN. LONG	
14	1	763357	AGIT MTR MT PLT CES 280	91
15	1	763359	AGIT MTR CPLR 280	91
16	2	900064	5/16UNC X 3/4 HEX BOLT	
17	2	900130	3/8UNC X 1 1/4 HEX BOLT	
18	2	914002	5/16UNC HEX STOVER NUT	
19	2	914004	3/8UNC HEX STOVER NUT	
20	2	920001	5/16 SAE FLAT WASHER	
21	2	920002	3/8 SAE FLAT WASHER	
22	1	470200	1/4UNC X 1 3/4 HEX BOLT SS	
23	1	763358	AGIT MTR MT YOKE CES 280	91
24	1	763361	AGIT CPLR SHIELD 280	91
25	1	900000	1/4UNC X 1/2 HEX BOLT	
26	1	914000	1/4UNC HEX STOVER NUT	
27	1	618634	9/16MJIC-45-9/16FJIC SWIV LBO	

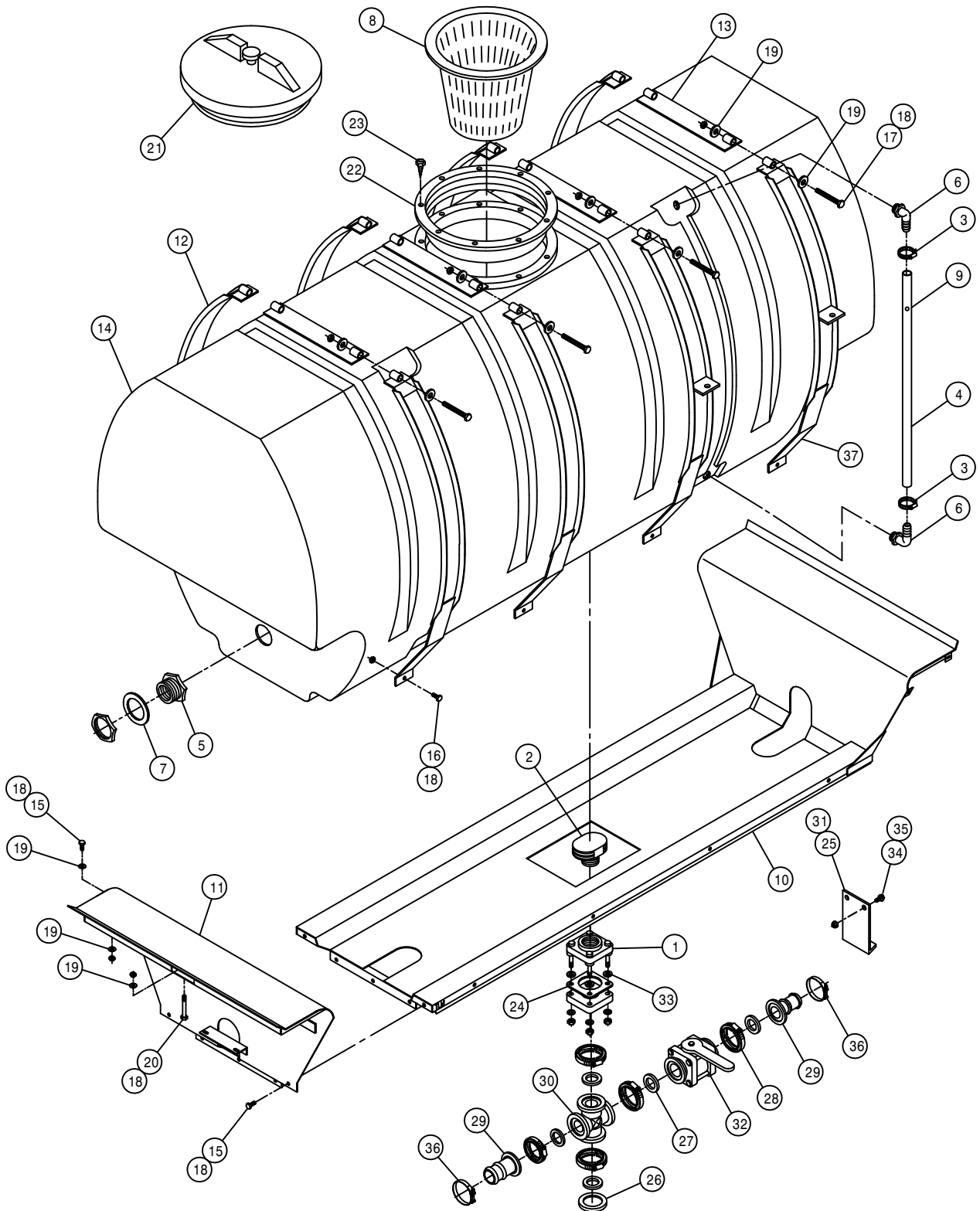

LEFT POLY SOLUTION TANK ASSEMBLY

DET.	QTY	PART NO.	DESCRIPTION
	1	500179	2"FLG TANK FTG,BOTDRN BLT POLY
	1	500077	VENT CAP, 2" W/O SCREEN,POLY
	2	520069	HOSE CLAMP NO 6 STAINLESS
	1	601245	HOSE, 1/2 X 42 CLEAR VINYL
	2	618548	1.25 PLASTIC FTG ASSY POLYTNK
	2	618556	1/4NPT-90-1/2 HOSE BARB,POLY
	2	763430	1 1/4 TANK FLANGE RUBBER SEAL
	1	763431	8" STRAINER BASKET, SOLU TANK
	1	763446	RED POLYPROPYLENE BALL 25/64"
	1	763652	POLY TANK CRADLE WLD, 2101 04
	1	763502	REAR CRADLE MT WLD, 2100 98
	6	763507	TANK BAND WLD, 2100 POLY 98
	4	763511	TANK BAND TIE WLD, 2100 98
	1	763513	500 GAL POLY SOLU TANK 98
	13	900129	3/8UNC X 1" HEX BOLT
	8	900130	3/8UNC X 1 1/4 HEX BOLT
	8	906138	3/8UNC X 3 1/2 HEX BOLT FULL
	33	914004	3/8UNC HEX STOVER NUT
	36	920002	3/8 SAE FLAT WASHER
	4	900140	3/8UNC X 4" HEX BOLT
	1	763408	LID, THD'D W/VENT, POLY TANK
	1	763409	10" THD'D RING FOR TANK LID
	8	763410	S.S. SCREW FOR CAP RING
	1	500087	GASKET,2" TANK FLG 500076/179
	1	763363	SOLU HOSE SUPPORT 280 POLY 91
	1	500156	2" FLANGE CAP PLUG POLY
	5	500158	1 1/2" GASKET FOR 2" FLANGE
	5	500160	2" FLANGE CLAMP, S.S.
	2	500162	2" FLANGE-1 1/2 HOSE BARB POLY
	1	500176	2" FLANGE CROSS POLY
	1	470000	CABLE TIE, 21" BLACK PLASTIC
	1	696142	BALL VLV, 2" FLANGE
	4	500100	FOOT GASKET,2" FLG 500076/179
	2	470118	1/4UNC X 3/4 FLANGE HEX BOLT
	2	470121	1/4UNC HEX FLANGE LOCK NUT
	2	520133	1.81/2.06 T-BOLT HOSE CLAMP SS
	2	763515	TANK BAND W/TAB WLD, 2100 98

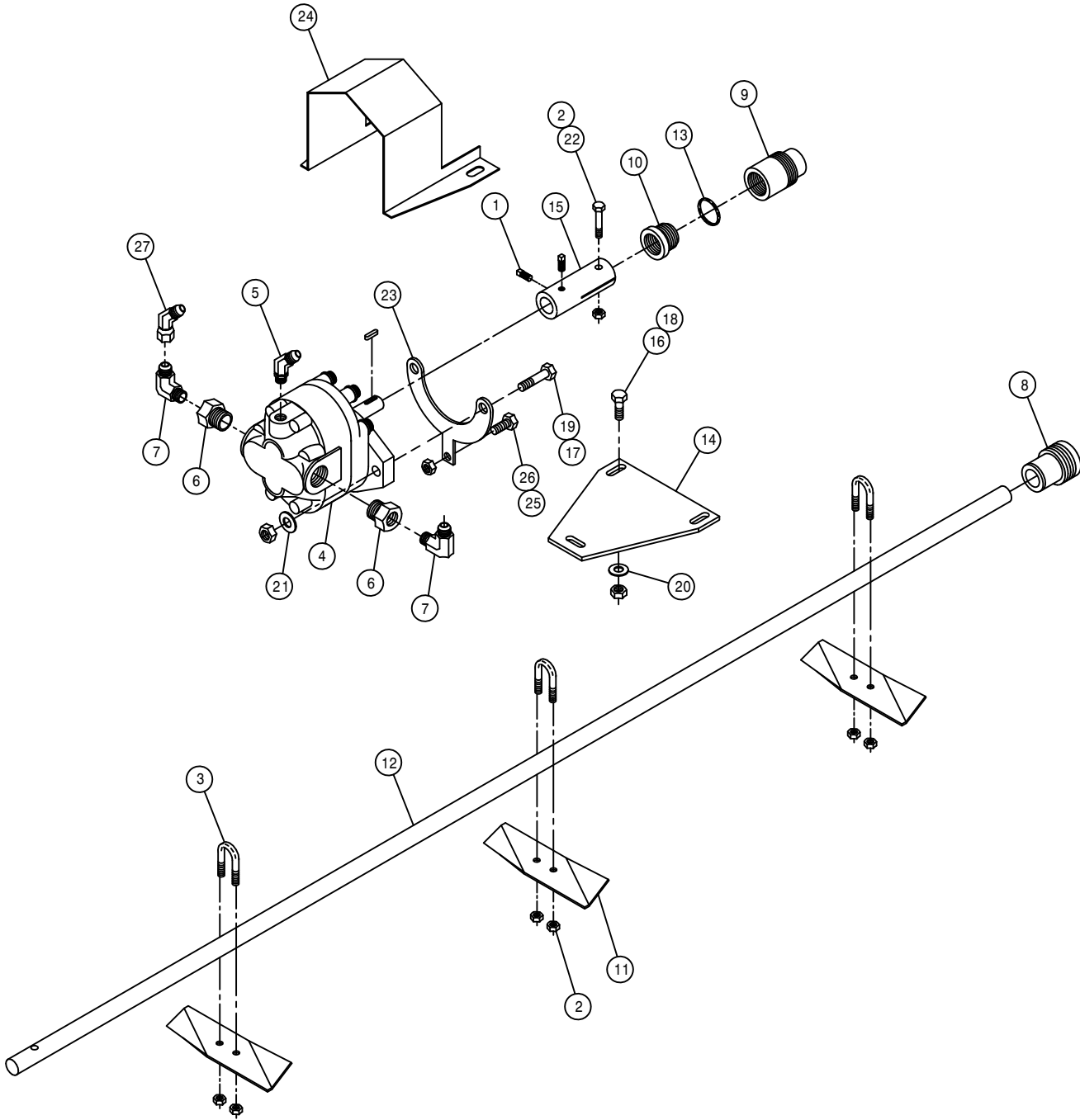

LH POLY TANK AGITATOR ASSEMBLY

DET.	QTY	PART NO.	DESCRIPTION
	1	2	470199 1/4UNC X 3/8 SQHD CUP SET SCR
	2	7	470089 1/4UNC HEX LOC NUT NYL INS SS
	3	3	470092 1/4UNC-3/4ID-1 1/4 U-BOLT SS
	4	1	610510 CESSNA GEAR MOTOR 1.48CI
	5	1	618338 9/16MJIC-45-1/4MNPT LBO
	6	2	618092 1 1/16MOR-1/2FNPT ADPTR
	7	2	618107 9/16MJIC-90-1/2MNPT LBO
	8	1	706403 FRT AGIT SHFT BRG, NYLON
	9	1	706401 REAR AGIT SHFT BRG, NYLON
	10	1	706402 AGIT SHFT GLAND NUT, NYLON
	11	3	763027 AGIT IMPELLER
	12	1	763514 AGIT SHAFT, 2100 98
	13	1	763217 GLAND PACKING, 13 IN. LONG
	14	1	763357 AGIT MTR MT PLT CES 280 91
	15	1	763359 AGIT MTR CPLR 280 91
	16	2	900064 5/16UNC X 3/4 HEX BOLT
	17	2	900130 3/8UNC X 1 1/4 HEX BOLT
	18	2	914002 5/16UNC HEX STOVER NUT
	19	2	914004 3/8UNC HEX STOVER NUT
	20	2	920001 5/16 SAE FLAT WASHER
	21	2	920002 3/8 SAE FLAT WASHER
	22	1	470200 1/4UNC X 1 3/4 HEX BOLT SS
	23	1	763358 AGIT MTR MT YOKE CES 280 91
	24	1	763361 AGIT CPLR SHIELD 280 91
	25	1	900000 1/4UNC X 1/2 HEX BOLT
	26	1	914000 1/4UNC HEX STOVER NUT
	27	1	618634 9/16MJIC-45-9/16FJIC SWIV LBO

60" SOLUTION SOLENOID ASSEMBLY (STANDARD)

DET. QTY PART NO. DESCRIPTION

DET.	QTY	PART NO.	DESCRIPTION
1	1	164422	SOLU MANIF VLV MT, HIVOL
2	3	520090	HOSE CLAMP NO 16 STAINLESS
3	1	601451	HOSE, 2 X 69 2F-1W EPDM
4	3	500173	1" FLANGE-90-1" HOSE BARB POLY
5	1	500154	2" FLANGE-2" HOSE BARB POLY
6	5	500157	1" FLANGE GASKET EPDM
7	5	500158	1 1/2" GASKET FOR 2" FLANGE
8	5	500159	1" FLANGE CLAMP, S.S.
9	5	500160	2" FLANGE CLAMP, S.S.
10	4	914004	3/8UNC HEX STOVER NUT
11	2	470136	3/8UNC-3 1/16ID-3 SQ U-BOLT
12	1	500180	2"FLANGE-90-2"FLANGE LBO POLY
13	1	500181	2" FLANGE PLUG W/1/4"FNPT POLY
14	1	690359	PRESSURE GA GLYCERI 100 PSI
15	1	696178	ELECT 3-BALL VLV,2"FLANGE TJET
16	3	696502	OUTLET FLG END-CAP FOR 696178
17	2	696503	O-RING,VLV FITTING FOR 696178
18	2	696504	CLAMP,VLV FITTING FOR 696178
19	3	520141	2.31/2.62 T-BOLT HOSE CLAMP SS
20	2	500058	2"NPT X 2" H BARB, POLY
21	1	601450	HOSE, 2 X 84 2F-1W EPDM
22	2	520056	HOSE CLAMP NO 56 STAINLESS
23	2	470118	1/4UNC X 3/4 FLANGE HEX BOLT
24	1	690529	RFM 100 FLOW METER, RAVEN
25	3	696501	FLANGE VLV TEE FOR 696178
26	3	900064	5/16UNC X 3/4 HEX BOLT
27	3	914002	5/16UNC HEX STOVER NUT
28	3	696500	450EC VLV W/FLG TEE FOR 696178
29	1	500119	1/2"NPT BR TEE-1/2"HBARB, POLY
30	1	500151	2" FLANGE TEE POLY
31	1	500175	1" FLANGE TEE POLY
32	1	500224	2" FLANGE PLUG W/1/2"FNPT POLY
33	1	500226	1" FLANGE PLUG W/1/4"FNPT POLY
34	1	618556	1/4NPT-90-1/2 HOSE BARB,POLY
35	1	470121	1/4UNC HEX FLANGE LOCK NUT

NOTE: ITEMS MARKED WITH A (*) ARE SOLUTION VALVE REPAIR PARTS.

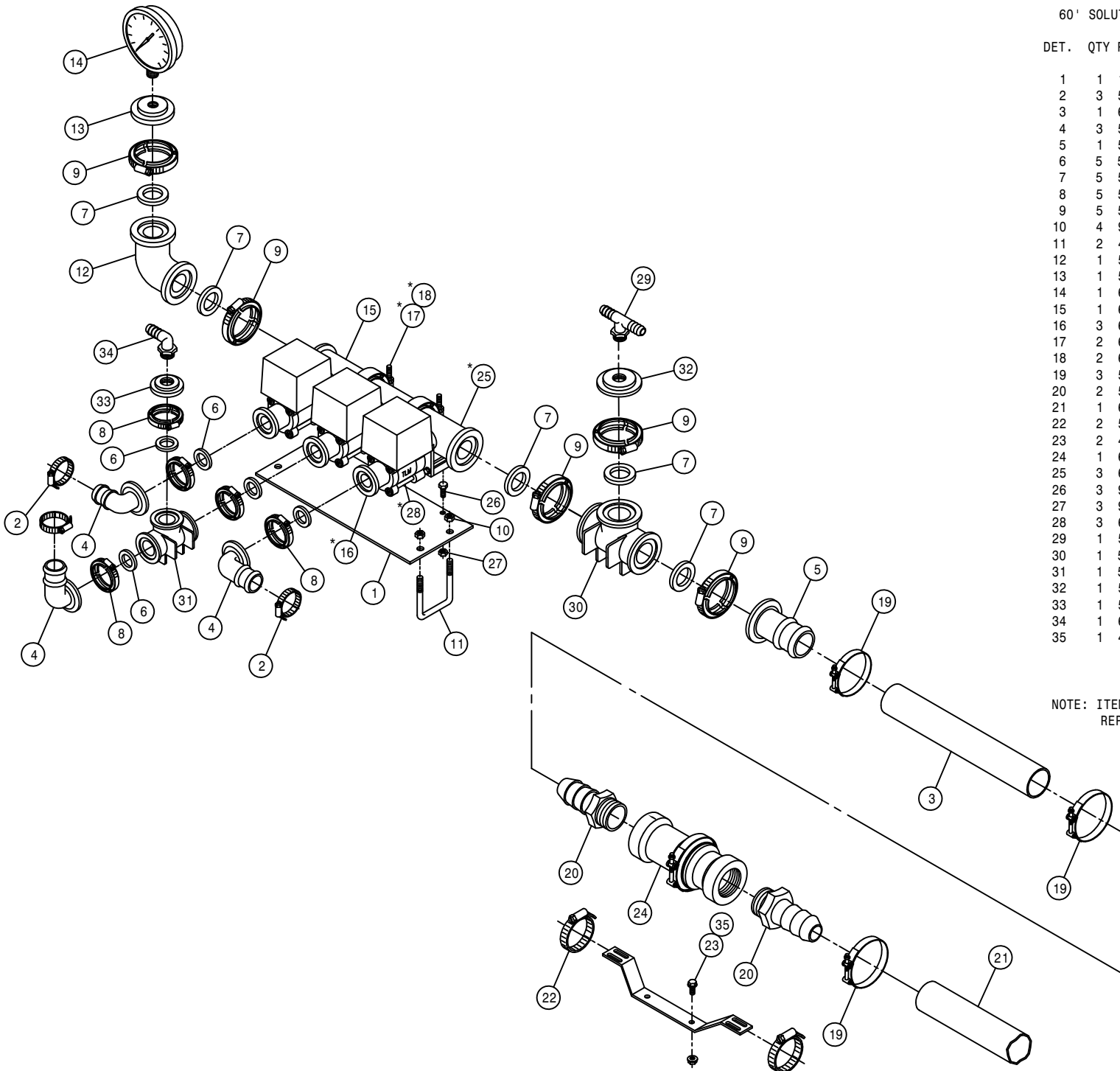

80'-90' SOLUTION SOLENOID ASSEMBLY (STANDARD)

DET. QTY PART NO. DESCRIPTION

DET.	QTY	PART NO.	DESCRIPTION
1	1	164422	SOLU MANIF VLV MT, HIVOL
2	5	520090	HOSE CLAMP NO 16 STAINLESS
3	2	500151	2" FLANGE TEE POLY
4	3	500173	1" FLANGE-90-1" HOSE BARB POLY
5	1	500154	2" FLANGE-2" HOSE BARB POLY
6	5	500157	1" FLANGE GASKET EPDM
7	7	500158	1 1/2" GASKET FOR 2" FLANGE
8	5	500159	1" FLANGE CLAMP, S.S.
9	7	500160	2" FLANGE CLAMP, S.S.
10	4	914004	3/8UNC HEX STOVER NUT
11	2	500172	2" FLANGE-1" HOSE BARB POLY
12	1	500180	2" FLANGE-90-2" FLANGE LBO POLY
13	1	500181	2" FLANGE PLUG W/1/4" FNPT POLY
14	1	690359	PRESSURE GA GLYCERI 100 PSI
15	1	696178	ELECT 3-BALL VLV, 2" FLANGE TJET
16	3	696502	OUTLET FLG END-CAP FOR 696178
17	2	696503	O-RING, VLV FITTING FOR 696178
18	2	696504	CLAMP, VLV FITTING FOR 696178
19	3	520141	2.31/2.62 T-BOLT HOSE CLAMP SS
20	2	500058	2" NPT X 2" H BARB, POLY
21	1	601450	HOSE, 2 X 84 2F-1W EPDM
22	2	520056	HOSE CLAMP NO 56 STAINLESS
23	2	470118	1/4UNC X 3/4 FLANGE HEX BOLT
24	1	690529	RFM 100 FLOW METER, RAVEN
25	1	601451	HOSE, 2 X 69 2F-1W EPDM
26	2	470136	3/8UNC-3 1/16ID-3 SQ U-BOLT
27	3	696501	FLANGE VLV TEE FOR 696178
28	3	900064	5/16UNC X 3/4 HEX BOLT
29	3	914002	5/16UNC HEX STOVER NUT
30	1	696500	450EC VLV W/FLG TEE FOR 696178
31	1	500175	1" FLANGE TEE POLY
32	1	500226	1" FLANGE PLUG W/1/4" FNPT POLY
33	1	618556	1/4NPT-90-1/2 HOSE BARB, POLY
34	2	470121	1/4UNC HEX FLANGE LOCK NUT

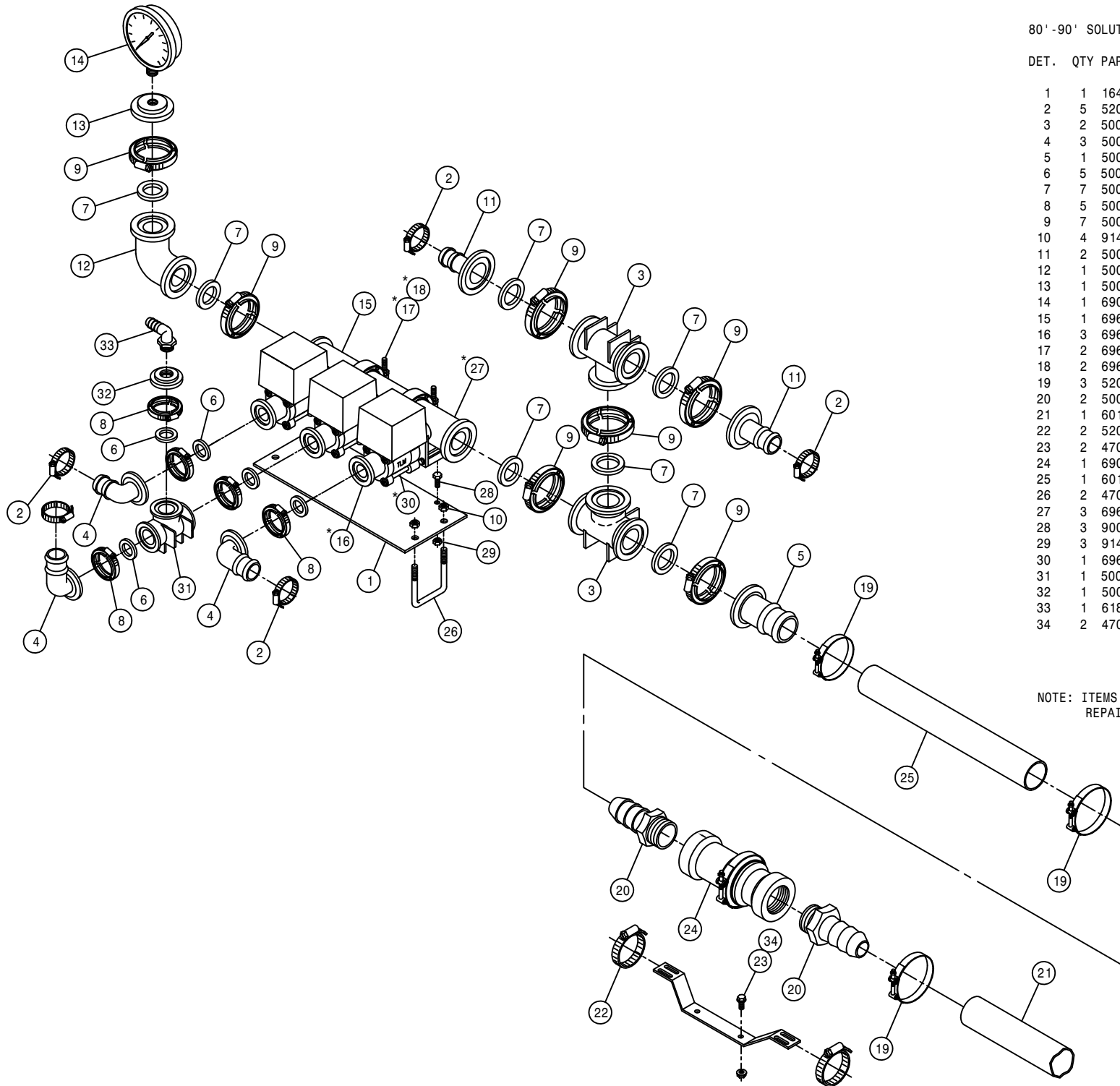

NOTE: ITEMS MARKED WITH A (*) ARE SOLUTION VALVE REPAIR PARTS.

RH 80' -90' OUTER BOOM VALVE (STANDARD)

DET. QTY PART NO. DESCRIPTION

1	1	164303	SOLU VLV MT	97
2	1	164304	SOLU VLV MT KEEPER	97
3	2	520090	HOSE CLAMP NO 16 STAINLESS	
4	4	500157	1" FLANGE GASKET	EPDM
5	4	500159	1" FLANGE CLAMP, S.S.	
6	1	500171	1" FLANGE-1" HOSE BARB	POLY
7	1	500173	1" FLANGE-90-1" HOSE BARB	POLY
8	1	696177	ELECT BALL VLV, 1" FLANGE	TJET
9	2	900007	1/4UNC X 2" HEX BOLT	
10	2	914000	1/4UNC HEX STOVER NUT	
11	1	500175	1" FLANGE TEE	POLY
12	1	500226	1" FLANGE PLUG W/1/4" FNPT	POLY
13	1	618556	1/4NPT-90-1/2 HOSE BARB, POLY	

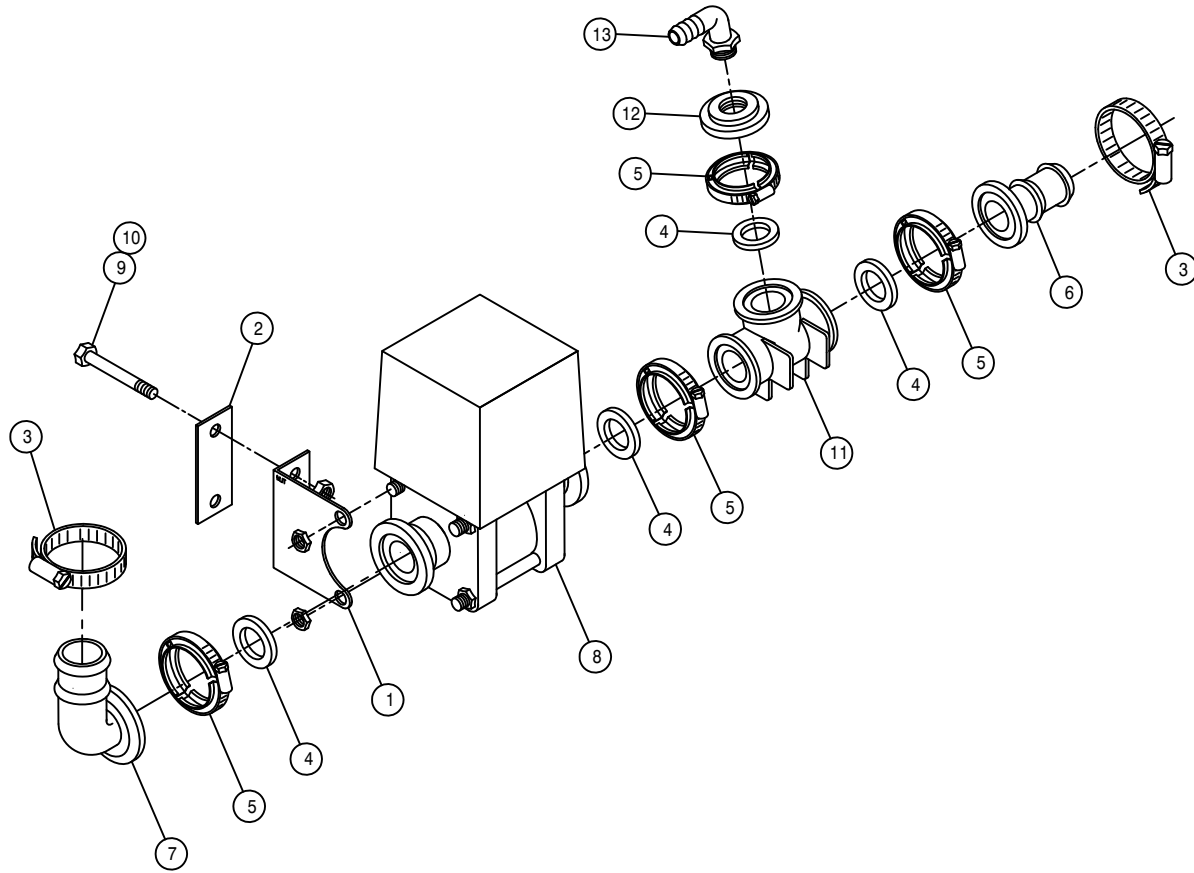

LH 80'-90' OUTER BOOM VALVE (STANDARD)

DET.	QTY	PART NO.	DESCRIPTION	
1	1	164303	SOLU VLV MT	97
2	1	164304	SOLU VLV MT KEEPER	97
3	2	520090	HOSE CLAMP NO 16 STAINLESS	
4	4	500157	1" FLANGE GASKET	EPDM
5	4	500159	1" FLANGE CLAMP, S.S.	
6	1	500171	1" FLANGE-1" HOSE BARB	POLY
7	1	500173	1" FLANGE-90-1" HOSE BARB	POLY
8	1	696177	ELECT BALL VLV,1"FLANGE	TJET
9	2	900007	1/4UNC X 2" HEX BOLT	
10	2	914000	1/4UNC HEX STOVER NUT	
11	1	500175	1" FLANGE TEE	POLY
12	1	500226	1" FLANGE PLUG W/1/4"FNPT	
13	1	618556	1/4NPT-90-1/2 HOSE BARB,POLY	

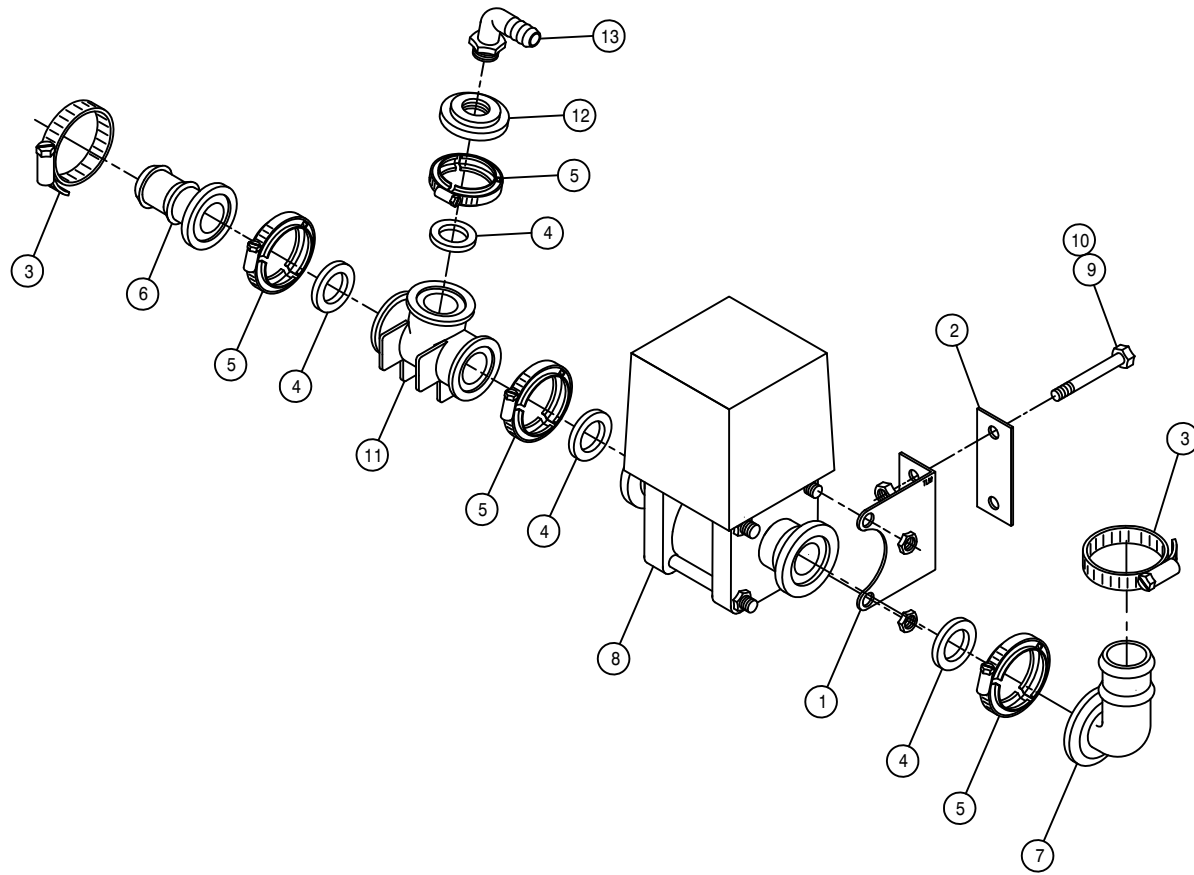

60' SOLUTION SOLENOID ASSEMBLY (HI-VOLUME)

DET. QTY PART NO. DESCRIPTION

DET.	QTY	PART NO.	DESCRIPTION
1	1	164422	SOLU MANIF VLV MT, HIVOL
2	3	520067	HOSE CLAMP NO 28 STAINLESS
3	2	470136	3/8UNC-3 1/16ID-3 SQ U-BOLT
4	3	500153	2" FLANGE-90-1 1/2 HBARB POLY
5	1	500154	2" FLANGE-2" HOSE BARB POLY
6	5	500157	1" FLANGE GASKET EPDM
7	8	500158	1 1/2" GASKET FOR 2" FLANGE
8	5	500159	1" FLANGE CLAMP, S.S.
9	8	500160	2" FLANGE CLAMP, S.S.
10	3	500161	2"FLANGE-1"FLANGE COUPLER,POLY
11	4	914004	3/8UNC HEX STOVER NUT
12	1	500180	2"FLANGE-90-2"FLANGE LBO POLY
13	1	500181	2" FLANGE PLUG W/1/4"FNPT POLY
14	1	690359	PRESSURE GA GLYCERI 100 PSI
15	1	696178	ELECT 3-BALL VLV,2"FLANGE TJET
16	3	696502	OUTLET FLG END-CAP FOR 696178
17	2	696503	O-RING,VLV FITTING FOR 696178
18	2	696504	CLAMP,VLV FITTING FOR 696178
19	3	520141	2.31/2.62 T-BOLT HOSE CLAMP SS
20	2	500058	2"NPT X 2" H BARB, POLY
21	1	601450	HOSE, 2 X 84 2F-1W EPDM
22	2	520056	HOSE CLAMP NO 56 STAINLESS
23	2	470118	1/4UNC X 3/4 FLANGE HEX BOLT
24	1	690529	RFM 100 FLOW METER, RAVEN
25	1	601451	HOSE, 2 X 69 2F-1W EPDM
26	3	696501	FLANGE VLV TEE FOR 696178
27	3	900064	5/16UNC X 3/4 HEX BOLT
28	3	914002	5/16UNC HEX STOVER NUT
29	3	696500	450EC VLV W/FLG TEE FOR 696178
30	1	500119	1/2"NPT BR TEE-1/2"HBARB, POLY
31	1	500151	2" FLANGE TEE POLY
32	1	500175	1" FLANGE TEE POLY
33	1	500224	2" FLANGE PLUG W/1/2"FNPT POLY
34	1	500226	1" FLANGE PLUG W/1/4"FNPT POLY
35	1	618556	1/4NPT-90-1/2 HOSE BARB,POLY
36	2	470121	1/4UNC HEX FLANGE LOCK NUT

NOTE: ITEMS MARKED WITH A (*) ARE SOLUTION VALVE REPAIR PARTS.

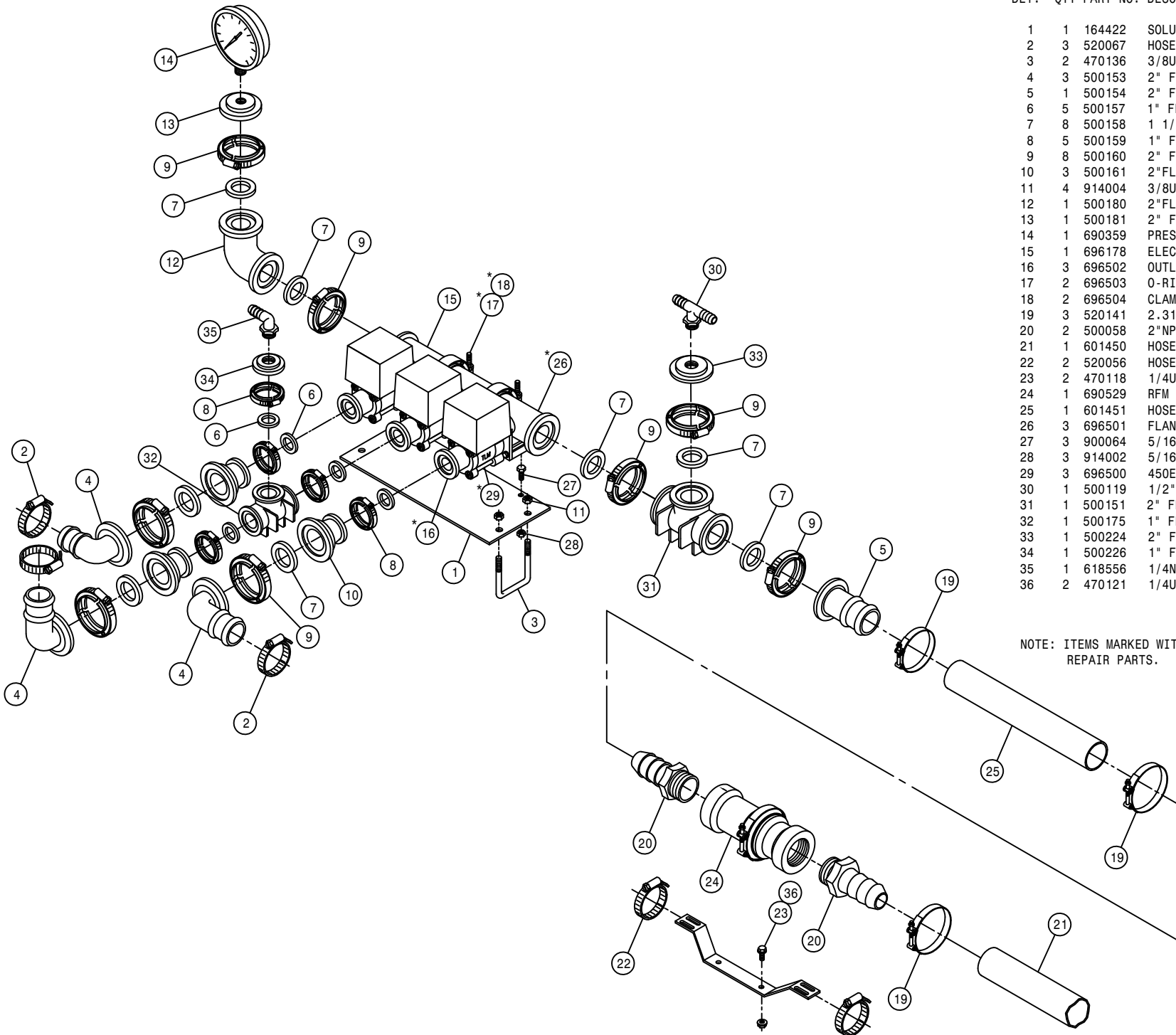

80'-90' SOLUTION SOLENOID (HI-VOLUME)

DET. QTY PART NO. DESCRIPTION

DET.	QTY	PART NO.	DESCRIPTION
1	1	164422	SOLU MANIF VLV MT, HIVOL
2	5	520067	HOSE CLAMP NO 28 STAINLESS
3	2	500151	2" FLANGE TEE POLY
4	3	500153	2" FLANGE-90-1 1/2 HBARB POLY
5	1	500154	2" FLANGE-2" HOSE BARB POLY
6	5	500157	1" FLANGE GASKET EPDM
7	10	500158	1 1/2" GASKET FOR 2" FLANGE
8	5	500159	1" FLANGE CLAMP, S.S.
9	10	500160	2" FLANGE CLAMP, S.S.
10	3	500161	2"FLANGE-1"FLANGE COUPLER,POLY
11	2	500162	2" FLANGE-1 1/2 HOSE BARB POLY
12	1	500180	2"FLANGE-90-2"FLANGE LBO POLY
13	1	500181	2" FLANGE PLUG W/1/4"FNPT POLY
14	1	690359	PRESSURE GA GLYCERI 100 PSI
15	1	696178	ELECT 3-BALL VLV,2"FLANGE TJET
16	3	696502	OUTLET FLG END-CAP FOR 696178
17	2	696503	O-RING,VLV FITTING FOR 696178
18	2	696504	CLAMP,VLV FITTING FOR 696178
19	3	520141	2.31/2.62 T-BOLT HOSE CLAMP SS
20	2	500058	2"NPT X 2" H BARB, POLY
21	1	601450	HOSE, 2 X 84 2F-1W EPDM
22	2	520056	HOSE CLAMP NO 56 STAINLESS
23	2	470118	1/4UNC X 3/4 FLANGE HEX BOLT
24	1	690529	RFM 100 FLOW METER, RAVEN
25	1	601451	HOSE, 2 X 69 2F-1W EPDM
26	2	470136	3/8UNC-3 1/16ID-3 SQ U-BOLT
27	4	914004	3/8UNC HEX STOVER NUT
28	3	696501	FLANGE VLV TEE FOR 696178
29	3	900064	5/16UNC X 3/4 HEX BOLT
30	3	914002	5/16UNC HEX STOVER NUT
31	3	696500	450EC VLV W/FLG TEE FOR 696178
32	1	500175	1" FLANGE TEE POLY
33	1	500226	1" FLANGE PLUG W/1/4"FNPT POLY
34	1	618556	1/4NPT-90-1/2 HOSE BARB,POLY
35	2	470121	1/4UNC HEX FLANGE LOCK NUT

NOTE: ITEMS MARKED WITH A (*) ARE SOLUTION VALVE REPAIR PARTS.

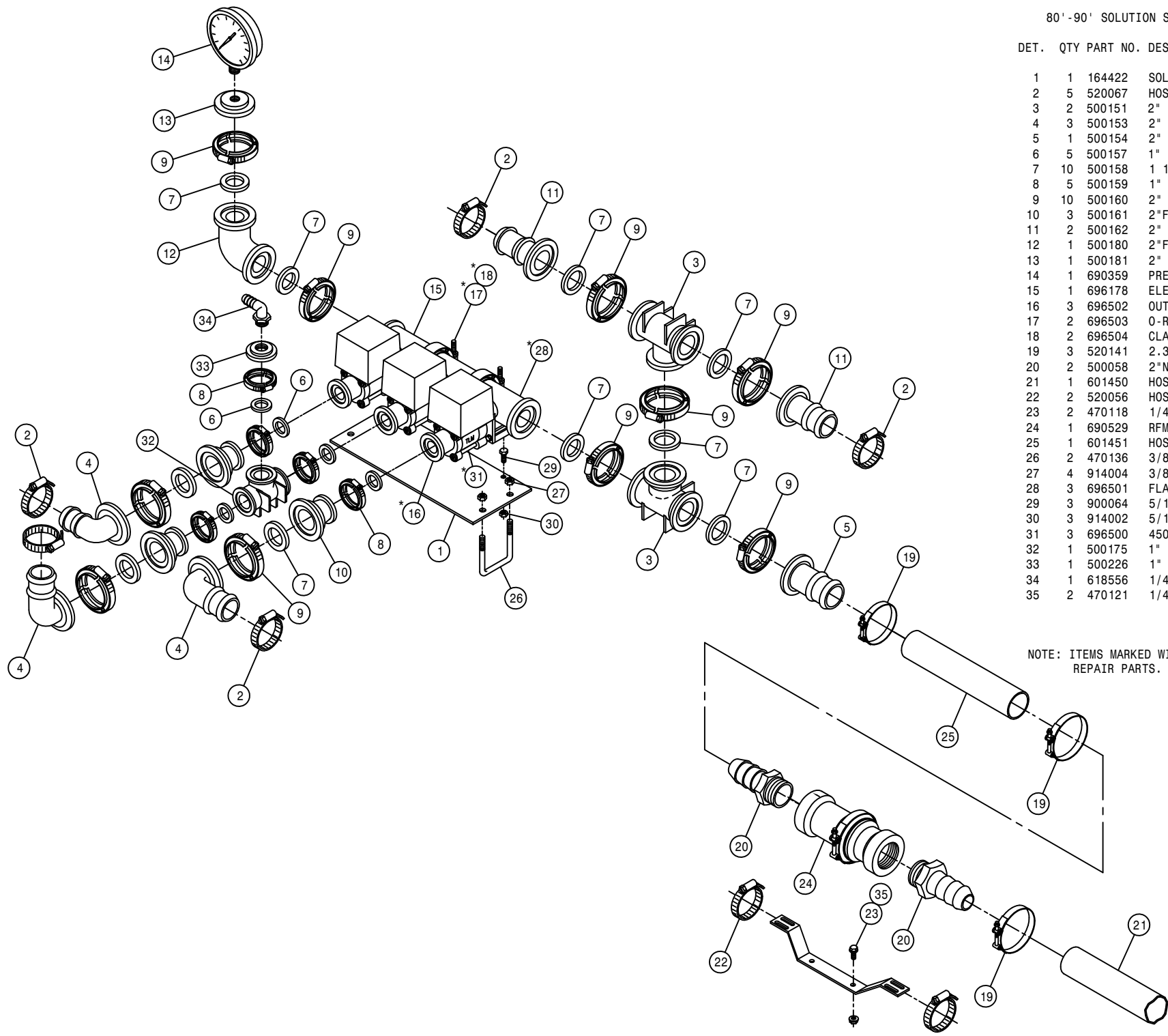

67

RH 80' -90' OUTER BOOM VALVE (HI-VOLUME)

DET. QTY PART NO. DESCRIPTION

1	1	164303	SOLU VLV MT	97
2	1	164304	SOLU VLV MT KEEPER	97
3	1	500066	1 1/2NPT-90-1 1/2 H BARB POLY	
4	1	500082	1 1/2NPT-90 EL, POLY	
5	1	500101	1 1/2"NPT SWIVEL	POLY
6	4	500157	1" FLANGE GASKET	EPDM
7	4	500159	1" FLANGE CLAMP, S.S.	
8	2	900064	5/16UNC X 3/4 HEX BOLT	
9	1	500162	2" FLANGE-1 1/2 HOSE BARB POLY	
10	1	500153	2" FLANGE-90-1 1/2 HBARB POLY	
11	4	910002	5/16UNC HEX NUT	
12	1	696177	ELECT BALL VLV,1"FLANGE	TJET
13	2	900007	1/4UNC X 2" HEX BOLT	
14	2	914000	1/4UNC HEX STOVER NUT	
15	3	520133	1.81/2.06 T-BOLT HOSE CLAMP SS	
16	2	914002	5/16UNC HEX STOVER NUT	
17	2	500158	1 1/2" GASKET FOR 2" FLANGE	
18	2	500160	2" FLANGE CLAMP, S.S.	
19	2	500161	2"FLANGE-1"FLANGE COUPLER,POLY	
20	1	473974	.31UNC-2.56ID-3.5 U-BOLT SS	
21	1	164199	HIGH VOLUME HOSE SWIVEL MT	
22	1	500032	1 1/2NPT X 1 1/2 H BARB, POLY	
23	2	520067	HOSE CLAMP NO 28 STAINLESS	
24	1	500175	1" FLANGE TEE	POLY
25	1	500226	1" FLANGE PLUG W/1/4"FNPT POLY	
26	1	618556	1/4NPT-90-1/2 HOSE BARB,POLY	

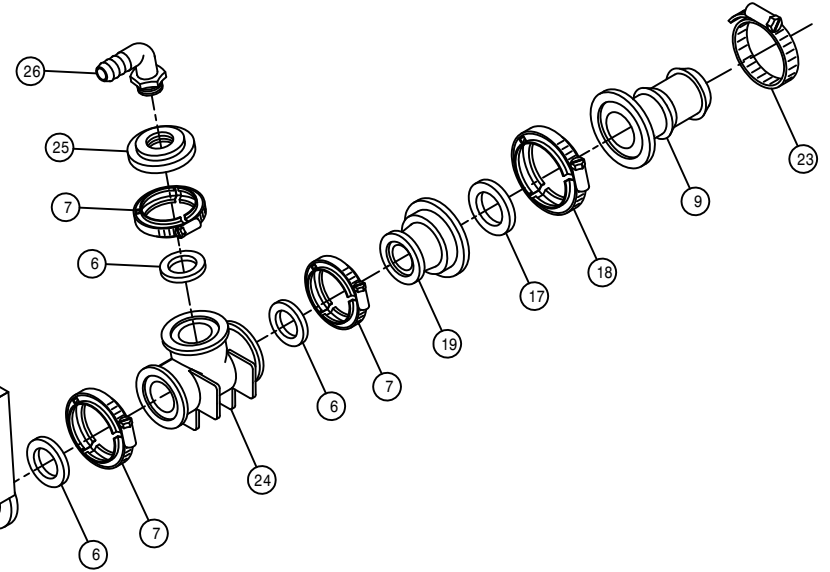
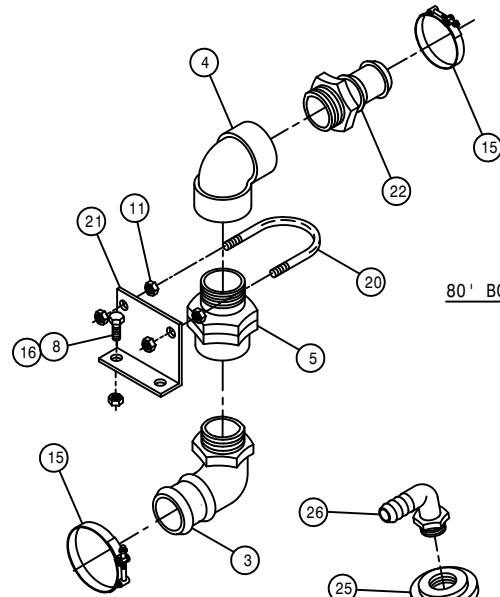

NOTE: DETAIL 15 IS USED WITH 1 1/2 I.D.
2F-1W EPDM HOSE.

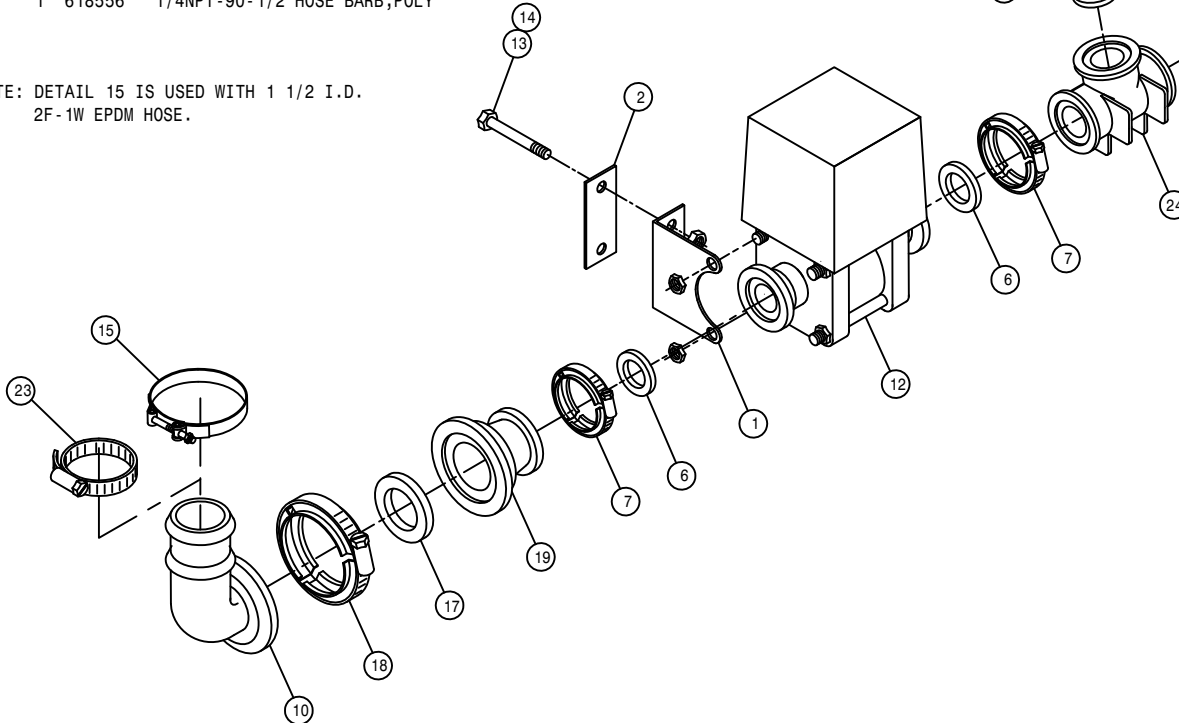

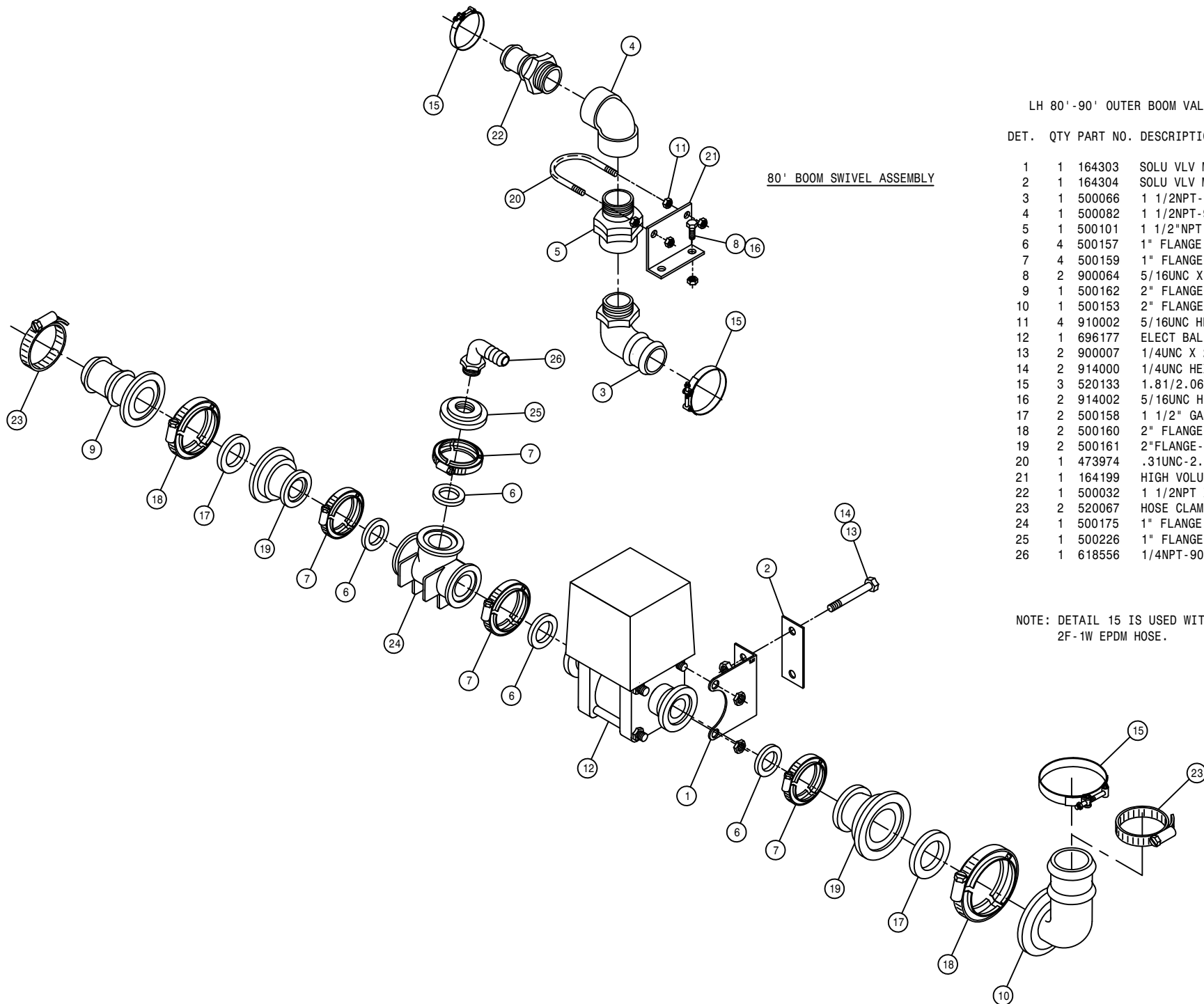

LH 80'-90' OUTER BOOM VALVE (HI-VOLUME)

DET.	QTY	PART NO.	DESCRIPTION	
1	1	164303	SOLU VLV MT	97
2	1	164304	SOLU VLV MT KEEPER	97
3	1	500066	1 1/2NPT-90-1 1/2 H BARB POLY	
4	1	500082	1 1/2NPT-90 EL, POLY	
5	1	500101	1 1/2"NPT SWIVEL	POLY
6	4	500157	1" FLANGE GASKET	EPDM
7	4	500159	1" FLANGE CLAMP, S.S.	
8	2	900064	5/16UNC X 3/4 HEX BOLT	
9	1	500162	2" FLANGE-1 1/2 HOSE BARB POLY	
10	1	500153	2" FLANGE-90-1 1/2 HBARB POLY	
11	4	910002	5/16UNC HEX NUT	
12	1	696177	ELECT BALL VLV, 1"FLANGE	TJET
13	2	900007	1/4UNC X 2" HEX BOLT	
14	2	914000	1/4UNC HEX STOVER NUT	
15	3	520133	1.81/2.06 T-BOLT HOSE CLAMP SS	
16	2	914002	5/16UNC HEX STOVER NUT	
17	2	500158	1 1/2" GASKET FOR 2" FLANGE	
18	2	500160	2" FLANGE CLAMP, S.S.	
19	2	500161	2"FLANGE-1"FLANGE COUPLER,POLY	
20	1	473974	.31UNC-2.56ID-3.5 U-BOLT SS	
21	1	164199	HIGH VOLUME HOSE SWIVEL MT	
22	1	500032	1 1/2NPT X 1 1/2 H BARB, POLY	
23	2	520067	HOSE CLAMP NO 28 STAINLESS	
24	1	500175	1" FLANGE TEE	POLY
25	1	500226	1" FLANGE PLUG W/1/4"FNPT POLY	
26	1	618556	1/4NPT-90-1/2 HOSE BARB,POLY	

NOTE: DETAIL 15 IS USED WITH 1 1/2 I.D. 2F-1W EPDM HOSE.

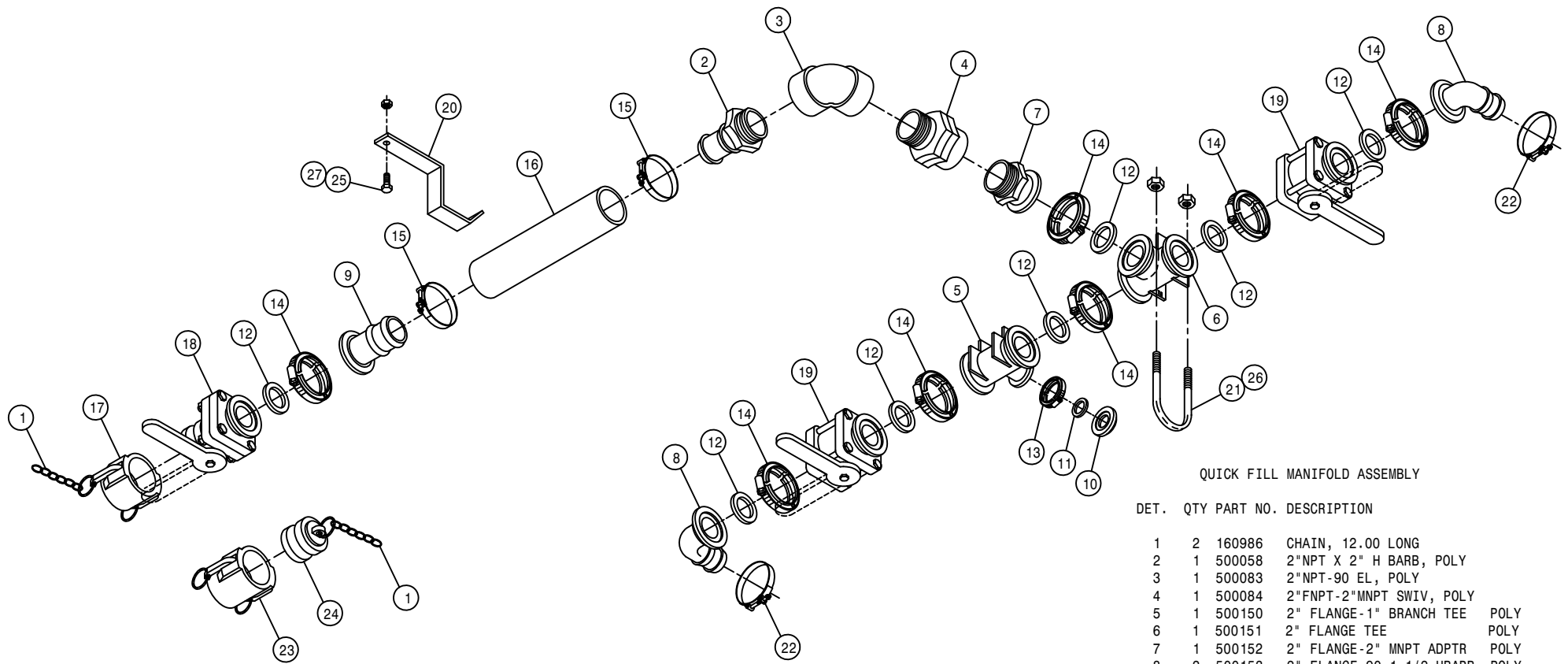

QUICK FILL MANIFOLD ASSEMBLY

DET. QTY PART NO. DESCRIPTION

DET.	QTY	PART NO.	DESCRIPTION
1	2	160986	CHAIN, 12.00 LONG
2	1	500058	2"NPT X 2" H BARB, POLY
3	1	500083	2"NPT-90 EL, POLY
4	1	500084	2"FNPT-2"MNPT SWIV, POLY
5	1	500150	2" FLANGE-1" BRANCH TEE POLY
6	1	500151	2" FLANGE TEE POLY
7	1	500152	2" FLANGE-2" MNPT ADPTR POLY
8	2	500153	2" FLANGE-90-1 1/2 HBARB POLY
9	1	500154	2" FLANGE-2" HOSE BARB POLY
10	1	500155	1" FLANGE CAP PLUG POLY
11	1	500157	1" FLANGE GASKET EPDM
12	7	500158	1 1/2" GASKET FOR 2" FLANGE
13	1	500159	1" FLANGE CLAMP, S.S.
14	7	500160	2" FLANGE CLAMP, S.S.
15	2	520141	2.31/2.62 T-BOLT HOSE CLAMP SS
16	1	601438	HOSE, 2 X 10 2F-1W EPDM
17	1	690623	CAP FOR 2.00 MALE COUPLER POLY
18	1	696141	BALL VLV,2"FLANGE/2"MALE ADPTR
19	2	696142	BALL VLV, 2" FLANGE
20	1	342620	QUICK FILL HOSE HANGER
21	2	472195	5/16UNC-2 11/16ID-3 9/16U-BOLT
22	2	520133	1.81/2.06 T-BOLT HOSE CLAMP SS
23	1	690390	2.00FNPT-FEMALE COUPLER POLY
24	1	690392	PLUG FOR 2.00 FEMALE COUPLER
25	1	900129	3/8UNC X 1" HEX BOLT
26	4	914002	5/16UNC HEX STOVER NUT
27	1	914004	3/8UNC HEX STOVER NUT

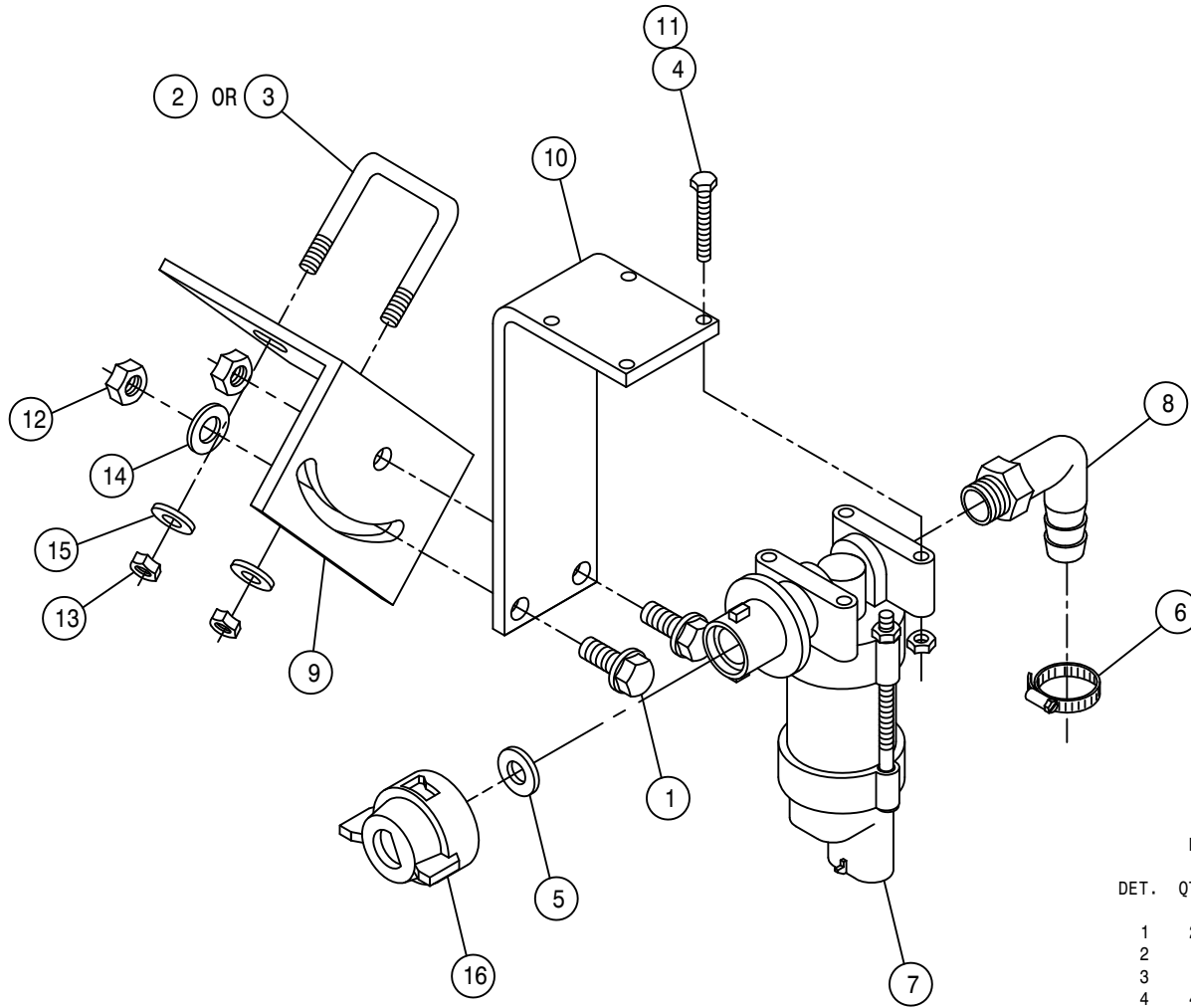

RIGHT FENCE ROW NOZZLE ASSEMBLY

DET. QTY PART NO. DESCRIPTION

DET.	QTY	PART NO.	DESCRIPTION
1	2	470118	1/4UNC X 3/4 FLANGE HEX BOLT
2	1	473973	.31UNC-1.31ID-2.0 SQ U-BOLT SS
3	1	473980	.31UNC-1.06ID-1.75SQ U-BOLT SS
4	4	473993	6-32 X 1 1/4 HH MACH SCR
5	1	737824	QUICK TEEJET SEAT GASKET
6	1	520070	HOSE CLAMP NO 8 STAINLESS
7	1	737875	NOZZLE BODY VALVE, 12VDC
8	1	618556	1/4NPT-90-1/2 HOSE BARB,POLY
9	1	737886	FENCE-ROW NOZZLE MT,284 01
10	1	737906	FENCE ROW NOZL BRKT
11	4	910022	6-32 HEX NUT
12	2	914000	1/4UNC HEX STOVER NUT
13	2	914002	5/16UNC HEX STOVER NUT
14	1	920000	1/4 SAE FLAT WASHER
15	2	920001	5/16 SAE FLAT WASHER
16	1	737822	CAP SET, YELLOW QUICK TEEJET

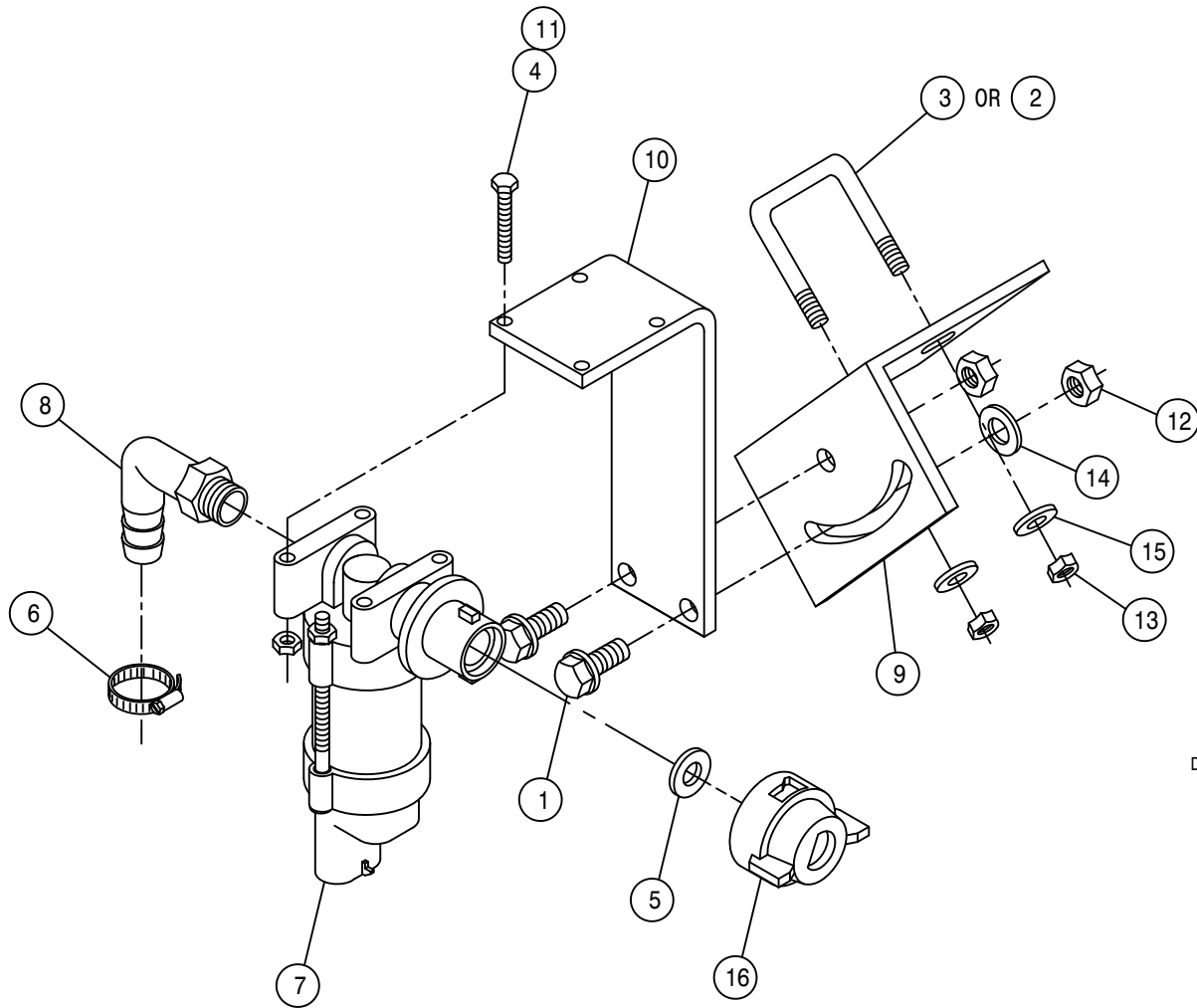

LEFT FENCE ROW NOZZLE ASSEMBLY

DET.	QTY	PART NO.	DESCRIPTION
	1	470118	1/4UNC X 3/4 FLANGE HEX BOLT
	1	473973	.31UNC-1.31ID-2.0 SQ U-BOLT SS
	1	473980	.31UNC-1.06ID-1.75SQ U-BOLT SS
	4	473993	6-32 X 1 1/4 HH MACH SCR
	1	737824	QUICK TEEJET SEAT GASKET
	1	520070	HOSE CLAMP NO 8 STAINLESS
	1	737875	NOZZLE BODY VALVE, 12VDC
	1	618556	1/4NPT-90-1/2 HOSE BARB,POLY
	1	737886	FENCE-ROW NOZZLE MT,284 01
	1	737906	FENCE ROW NOZL BRKT
	4	910022	6-32 HEX NUT
	2	914000	1/4UNC HEX STOVER NUT
	2	914002	5/16UNC HEX STOVER NUT
	1	920000	1/4 SAE FLAT WASHER
	2	920001	5/16 SAE FLAT WASHER
	1	737822	CAP SET, YELLOW QUICK TEEJET

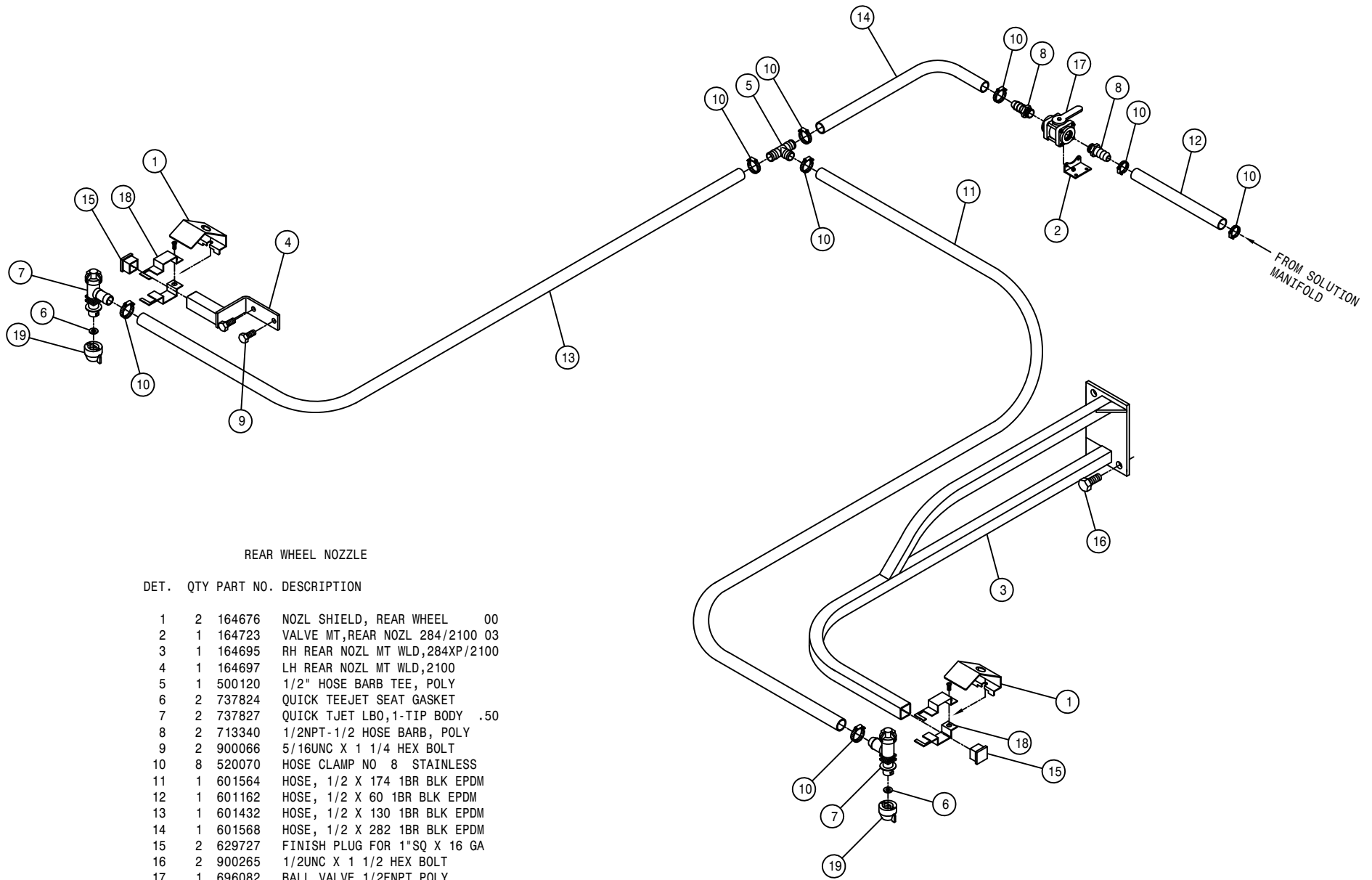

REAR WHEEL NOZZLE

DET.	QTY	PART NO.	DESCRIPTION
	1	2 164676	NOZL SHIELD, REAR WHEEL 00
	2	1 164723	VALVE MT, REAR NOZL 284/2100 03
	3	1 164695	RH REAR NOZL MT WLD, 284XP/2100
	4	1 164697	LH REAR NOZL MT WLD, 2100
	5	1 500120	1/2" HOSE BARB TEE, POLY
	6	2 737824	QUICK TEEJET SEAT GASKET
	7	2 737827	QUICK TJET LBO, 1-TIP BODY .50
	8	2 713340	1/2NPT-1/2 HOSE BARB, POLY
	9	2 900066	5/16UNC X 1 1/4 HEX BOLT
	10	8 520070	HOSE CLAMP NO 8 STAINLESS
	11	1 601564	HOSE, 1/2 X 174 1BR BLK EPDM
	12	1 601162	HOSE, 1/2 X 60 1BR BLK EPDM
	13	1 601432	HOSE, 1/2 X 130 1BR BLK EPDM
	14	1 601568	HOSE, 1/2 X 282 1BR BLK EPDM
	15	2 629727	FINISH PLUG FOR 1" SQ X 16 GA
	16	2 900265	1/2UNC X 1 1/2 HEX BOLT
	17	1 696082	BALL VALVE 1/2FNPT POLY
	18	2 737817	NOZL MT CLMP, 1.00 SQ SS, Q-TJET
	19	2 737822	CAP SET, YELLOW QUICK TEEJET

SOLUTION HOISING FOR 60' BOOM (STANDARD)

DET. QTY PART NO. DESCRIPTION

1	1	601451	HOSE, 2 X 69 2F-1W EPDM
2	1	601428	HOSE, 1 1/2 X 125 2F-1W EPDM
3	1	601429	HOSE, 1 1/2 X 143 2F-1W EPDM
4	2	601430	HOSE, 1 1/2 X 183 2F-1W EPDM
5	1	601456	HOSE, 3/4 X 117 1BR BLK EPDM
6	1	601457	HOSE, 3/4 X 130 1BR BLK EPDM
7	1	601425	HOSE, 1 X 192 2F-1W EPDM
8	1	601450	HOSE, 2 X 84 2F-1W EPDM
9	1	601438	HOSE, 2 X 10 2F-1W EPDM
10	2	690412	HOSE SPRING GUARD 2IN X 12 LG
11	1	601458	HOSE, 1 X 51 1BR BLK EPDM
12	1	601460	HOSE, 1 X 248 1BR BLK EPDM
13	1	601461	HOSE, 1 X 262 1BR BLK EPDM
14	2	342635	NYL HOSE SLEEVE, 2.64ID X 60.00
15	3	342638	NYL HOSE SLEEVE, 2.96ID X 65.00
16	2	601571	HOSE, 1/2 X 420 1BR BLK EPDM

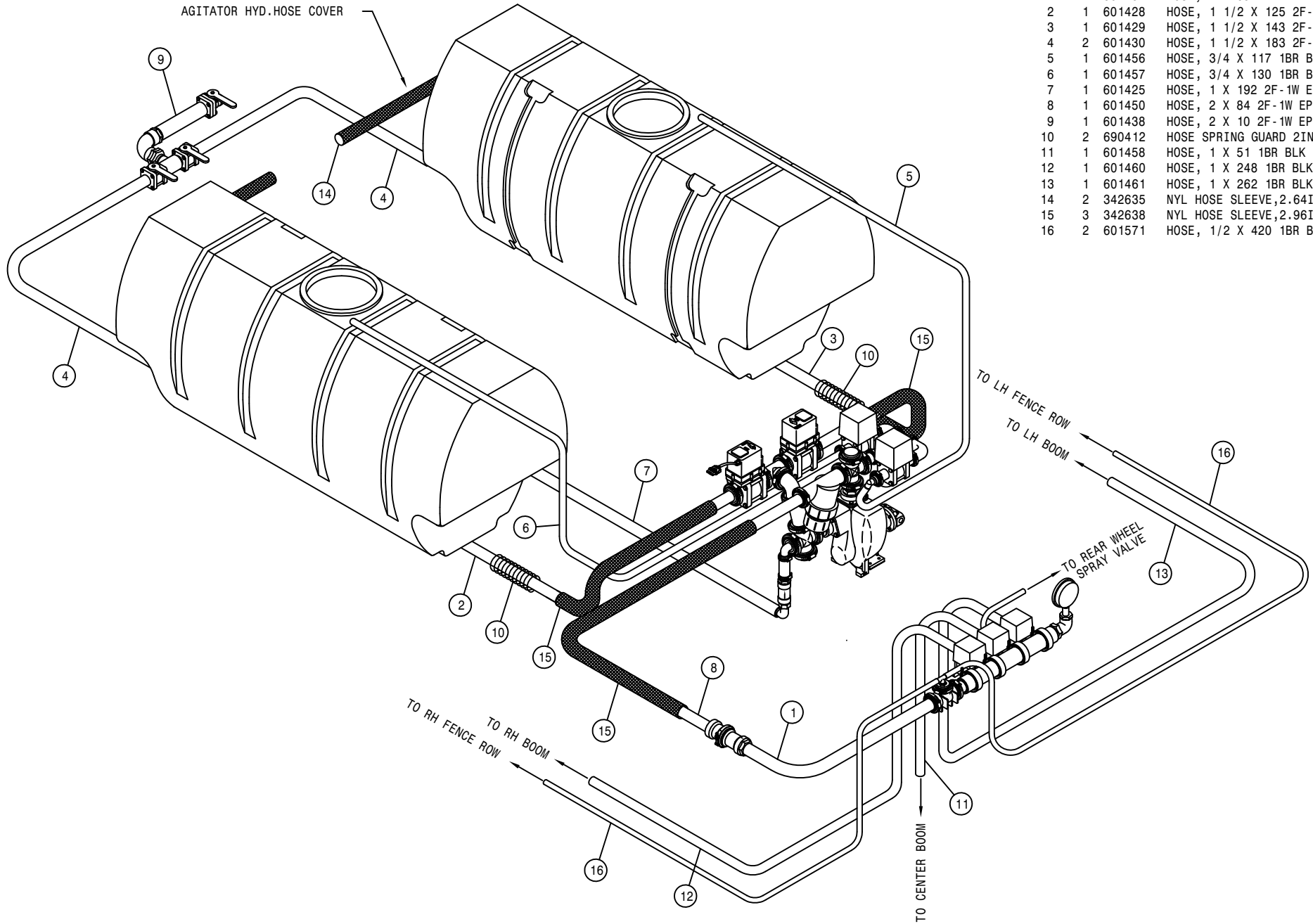

SOLUTION HOISING FOR 80'-90' BOOM (STANDARD)

DET. QTY PART NO. DESCRIPTION

1	1	601451	HOSE, 2 X 69 2F-1W EPDM
2	1	601428	HOSE, 1 1/2 X 125 2F-1W EPDM
3	1	601429	HOSE, 1 1/2 X 143 2F-1W EPDM
4	2	601430	HOSE, 1 1/2 X 183 2F-1W EPDM
5	1	601456	HOSE, 3/4 X 117 1BR BLK EPDM
6	1	601457	HOSE, 3/4 X 130 1BR BLK EPDM
7	1	601425	HOSE, 1 X 192 2F-1W EPDM
8	1	601450	HOSE, 2 X 84 2F-1W EPDM
9	1	601438	HOSE, 2 X 10 2F-1W EPDM
10	2	690412	HOSE SPRING GUARD 2IN X 12 LG
11	1	601458	HOSE, 1 X 51 1BR BLK EPDM
12	1	601460	HOSE, 1 X 248 1BR BLK EPDM
13	1	601461	HOSE, 1 X 262 1BR BLK EPDM
14	2	342635	NYL HOSE SLEEVE, 2.64ID X 60.00
15	3	342638	NYL HOSE SLEEVE, 2.96ID X 65.00
16	2	601570	HOSE, 1/2 X 236 1BR BLK EPDM
17	2	601167	HOSE, 1/2 X 300 1BR BLK EPDM
18	2	601390	HOSE, 1 X 160 1BR BLK EPDM
19	1	601459	HOSE, 1 X 245 1BR BLK EPDM
20	1	601462	HOSE, 1 X 294 1BR BLK EPDM

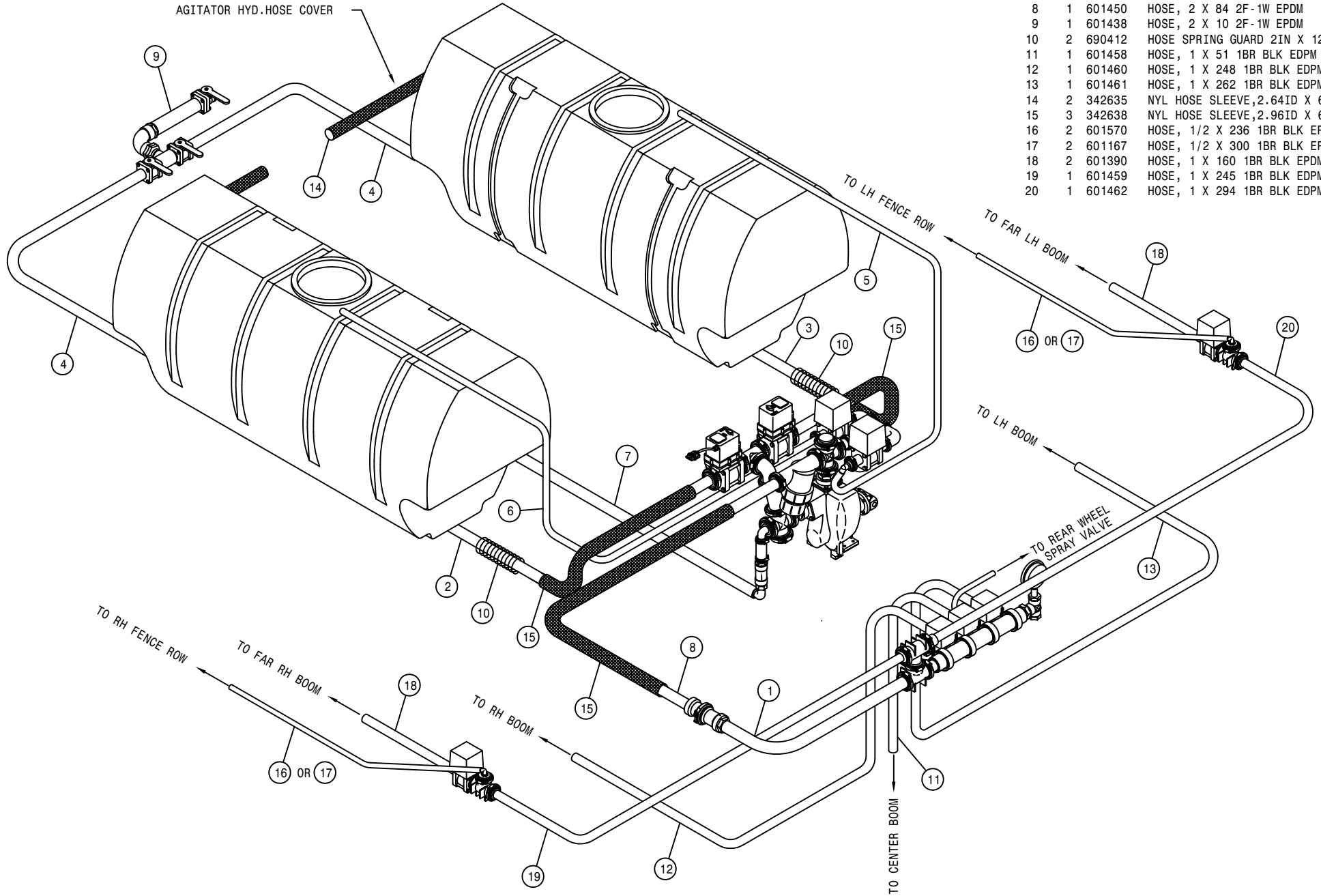

AGITATOR HYD. HOSE COVER

SOLUTION HOISING FOR 60' BOOM (HI-VOLUME)

DET. QTY PART NO. DESCRIPTION

DET.	QTY	PART NO.	DESCRIPTION
1	1	601451	HOSE, 2 X 69 2F-1W EPDM
2	1	601428	HOSE, 1 1/2 X 125 2F-1W EPDM
3	1	601429	HOSE, 1 1/2 X 143 2F-1W EPDM
4	2	601430	HOSE, 1 1/2 X 183 2F-1W EPDM
5	1	601456	HOSE, 3/4 X 117 1BR BLK EPDM
6	1	601457	HOSE, 3/4 X 130 1BR BLK EPDM
7	1	601425	HOSE, 1 X 192 2F-1W EPDM
8	1	601450	HOSE, 2 X 84 2F-1W EPDM
9	1	601438	HOSE, 2 X 10 2F-1W EPDM
10	2	690412	HOSE SPRING GUARD 2IN X 12 LG
11	1	601538	HOSE, 1 1/2 X 51 2BR BLK EPDM
12	1	601540	HOSE, 1 1/2 X 248 2BR BLK EPDM
13	1	601541	HOSE, 1 1/2 X 262 2BR BLK EPDM
14	2	342635	NYL HOSE SLEEVE, 2.64ID X 60.00
15	3	342638	NYL HOSE SLEEVE, 2.96ID X 65.00
16	2	601571	HOSE, 1/2 X 420 1BR BLK EPDM

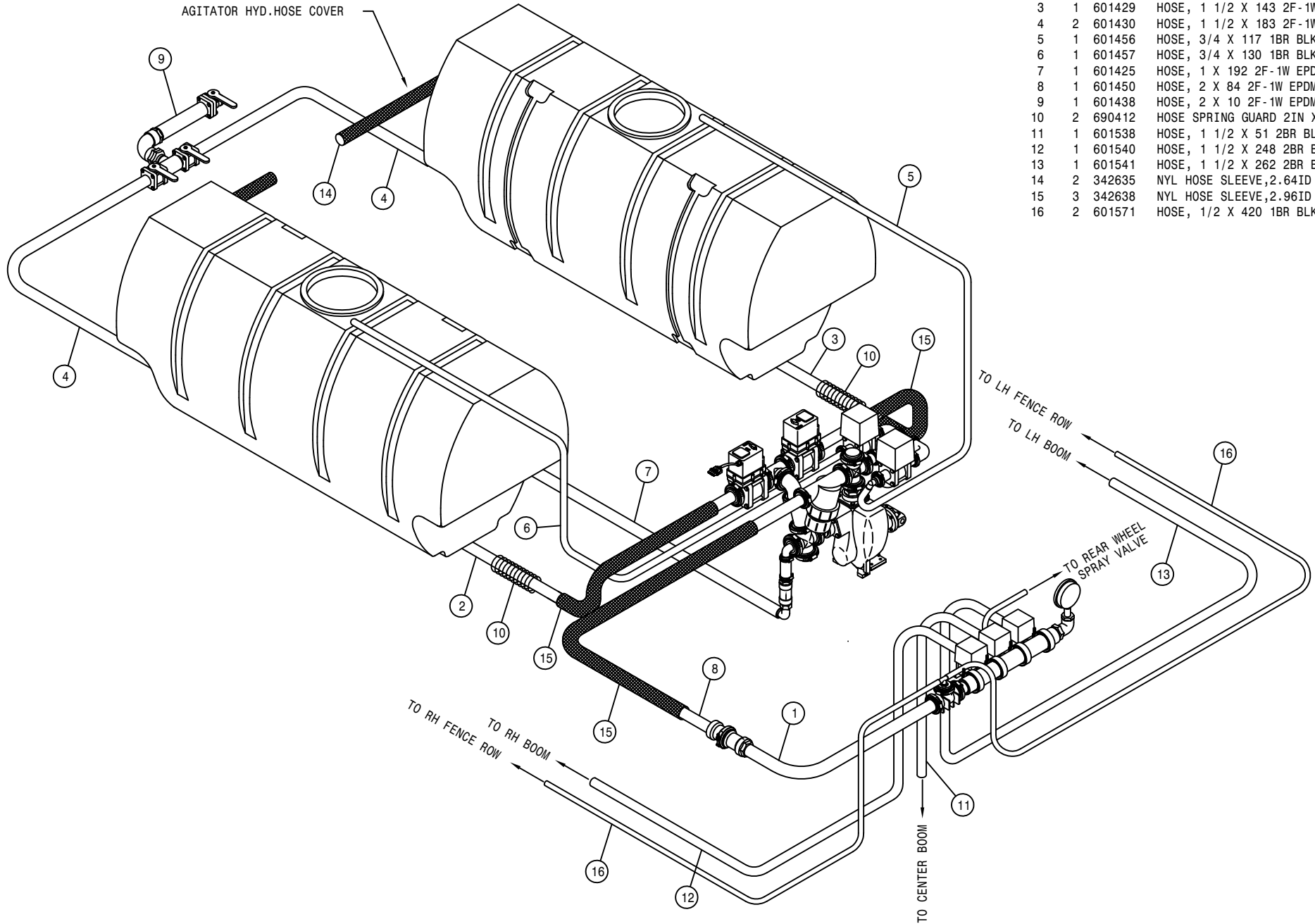

SOLUTION HOSE FOR 80' -90' BOOM (HI-VOLUME)

DET. QTY PART NO. DESCRIPTION

1	1	601451	HOSE, 2 X 69 2F-1W EPDM
2	1	601428	HOSE, 1 1/2 X 125 2F-1W EPDM
3	1	601429	HOSE, 1 1/2 X 143 2F-1W EPDM
4	2	601430	HOSE, 1 1/2 X 183 2F-1W EPDM
5	1	601456	HOSE, 3/4 X 117 1BR BLK EPDM
6	1	601457	HOSE, 3/4 X 130 1BR BLK EPDM
7	1	601425	HOSE, 1 X 192 2F-1W EPDM
8	1	601450	HOSE, 2 X 84 2F-1W EPDM
9	1	601438	HOSE, 2 X 10 2F-1W EPDM
10	2	690412	HOSE SPRING GUARD 2IN X 12 LG
11	1	601538	HOSE, 1 1/2 X 51 2BR BLK EPDM
12	1	601540	HOSE, 1 1/2 X 248 2BR BLK EPDM
13	1	601541	HOSE, 1 1/2 X 262 2BR BLK EPDM
14	2	342635	NYL HOSE SLEEVE, 2.64ID X 60.00
15	3	342638	NYL HOSE SLEEVE, 2.96ID X 65.00
16	2	601570	HOSE, 1/2 X 236 1BR BLK EPDM
17	2	601167	HOSE, 1/2 X 300 1BR BLK EPDM
18	2	601445	HOSE, 1 1/2 X 160 2F-1W EPDM
19	1	601539	HOSE, 1 1/2 X 245 2BR BLK EPDM
20	1	601542	HOSE, 1 1/2 X 294 2BR BLK EPDM
21	2	601444	HOSE, 1 1/2 X 51 2F-1W EPDM
22	2	601469	HOSE, 1 1/2 X 110 2F-1W EPDM

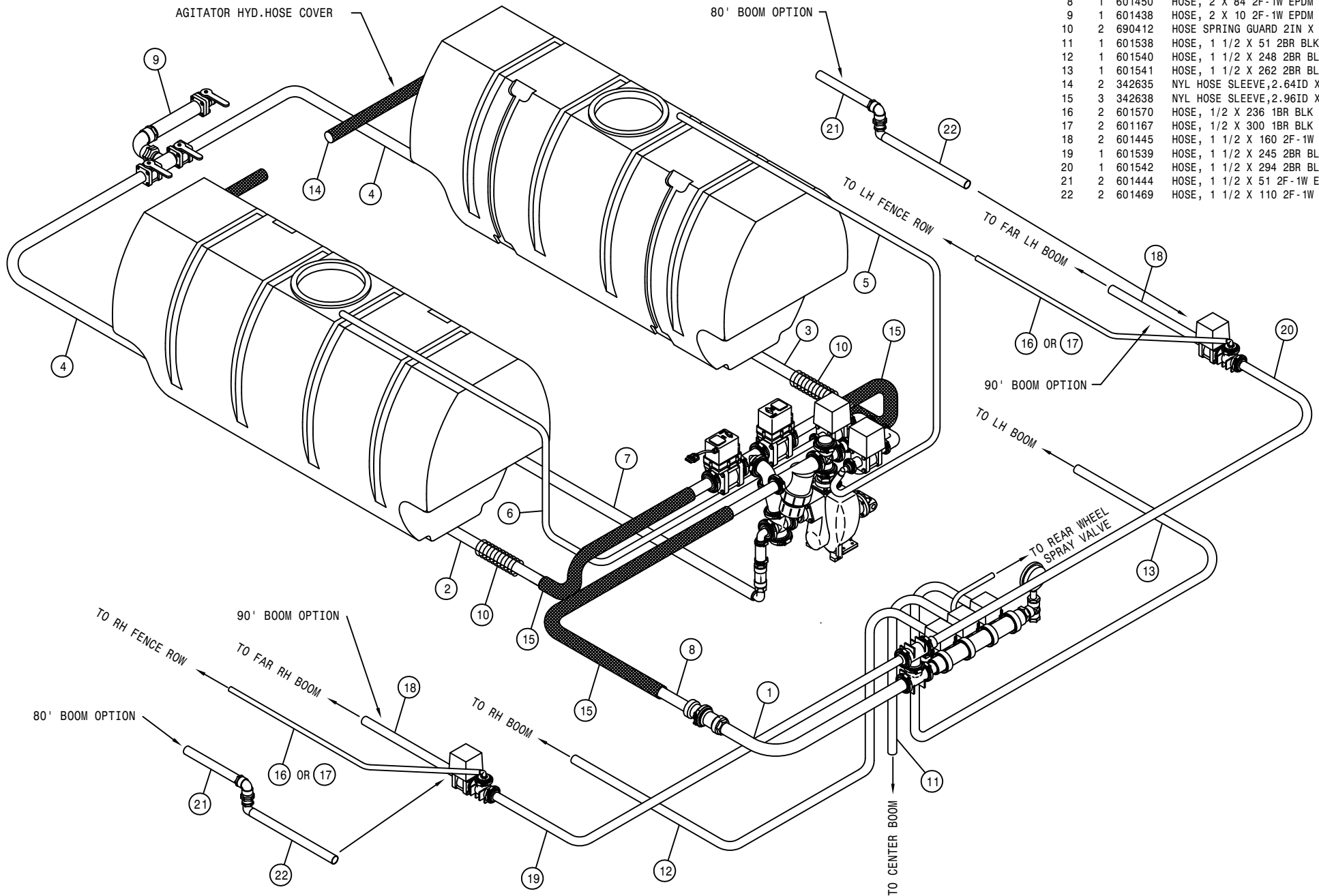

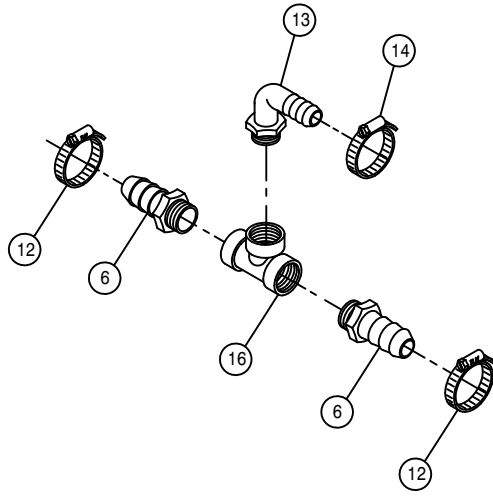

FEEDER TEE ASSEMBLY (STANDARD VOLUME)

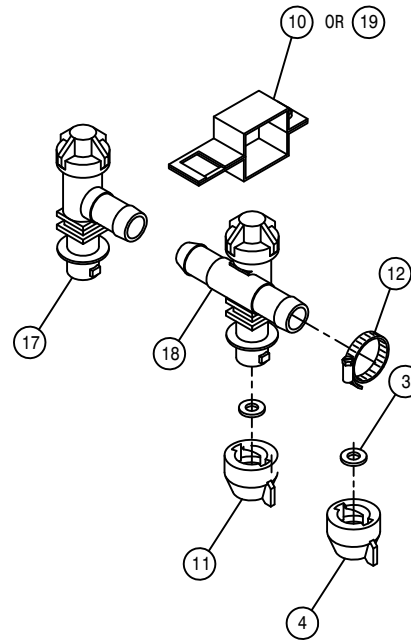

SINGLE TIP NOZZLE SPACING

BOOM FEEDER TEE ASSEMBLY

DET. QTY PART NO. DESCRIPTION

1	2	500108	1"NPT-3/4" HOSE BARB	POLY
2	1	500117	1"NPT-90-1 1/2"HOSE BARB, POLY	
3	4	737824	QUICK TEEJET SEAT GASKET	
4	2	737825	QUICK SHUT-OFF CAP	
5	1	520067	HOSE CLAMP NO 28 STAINLESS	
6	2	500022	3/4NPT-3/4HOSE BARB, POLY	
7	1	500075	1" NPT PIPE TEE, POLY	
8	1	737833	QUICK TJET LBO,3-TIP BODY .75	
9	1	737834	QUICK TJET TEE,3-TIP BODY .75	
10	2	737817	NOZL MT CLMP,1.00 SQ SS,Q-TJET	
11	2	737822	CAP SET, YELLOW QUICK TEEJET	
12	6	520055	HOSE CLAMP NO 12 STAINLESS	
13	1	500026	3/4NPT-90-1"HOSE BARB, POLY	
14	1	520090	HOSE CLAMP NO 16 STAINLESS	
15	1	520133	1.81/2.06 T-BOLT HOSE CLAMP SS	
16	1	505218	3/4 NPT PIPE TEE, POLY	
17	1	737829	QUICK TJET LBO,1-TIP BODY .75	
18	1	737830	QUICK TJET TEE,1-TIP BODY .75	
19	2	737832	NOZL MT CLMP,1.25 SQ,SS Q-TJET	

NOTE: DETAIL 15 IS USED WITH 1 1/2 I.D.
2F-1W EPDM HOSE.

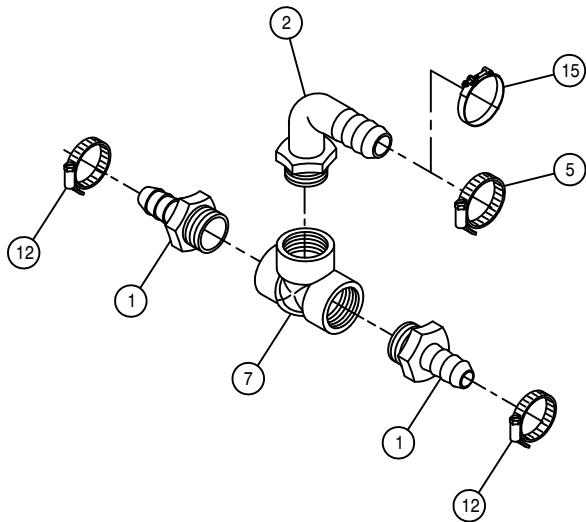

FEEDER TEE ASSEMBLY (HIGH VOLUME)

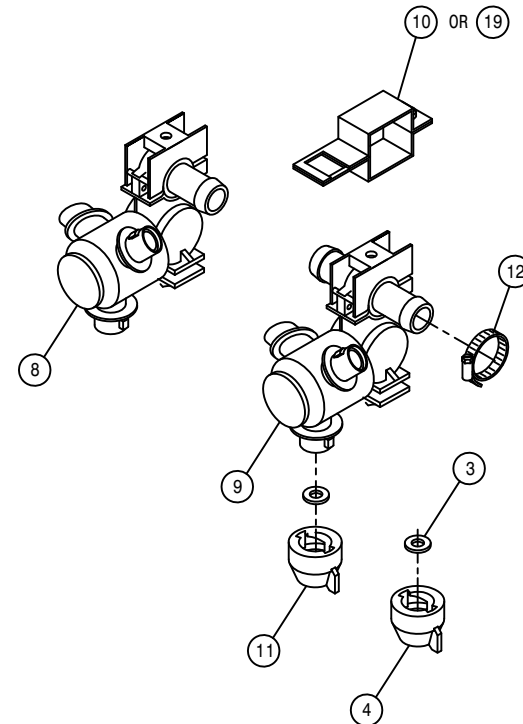

TRIPLE TIP NOZZLE SPACING

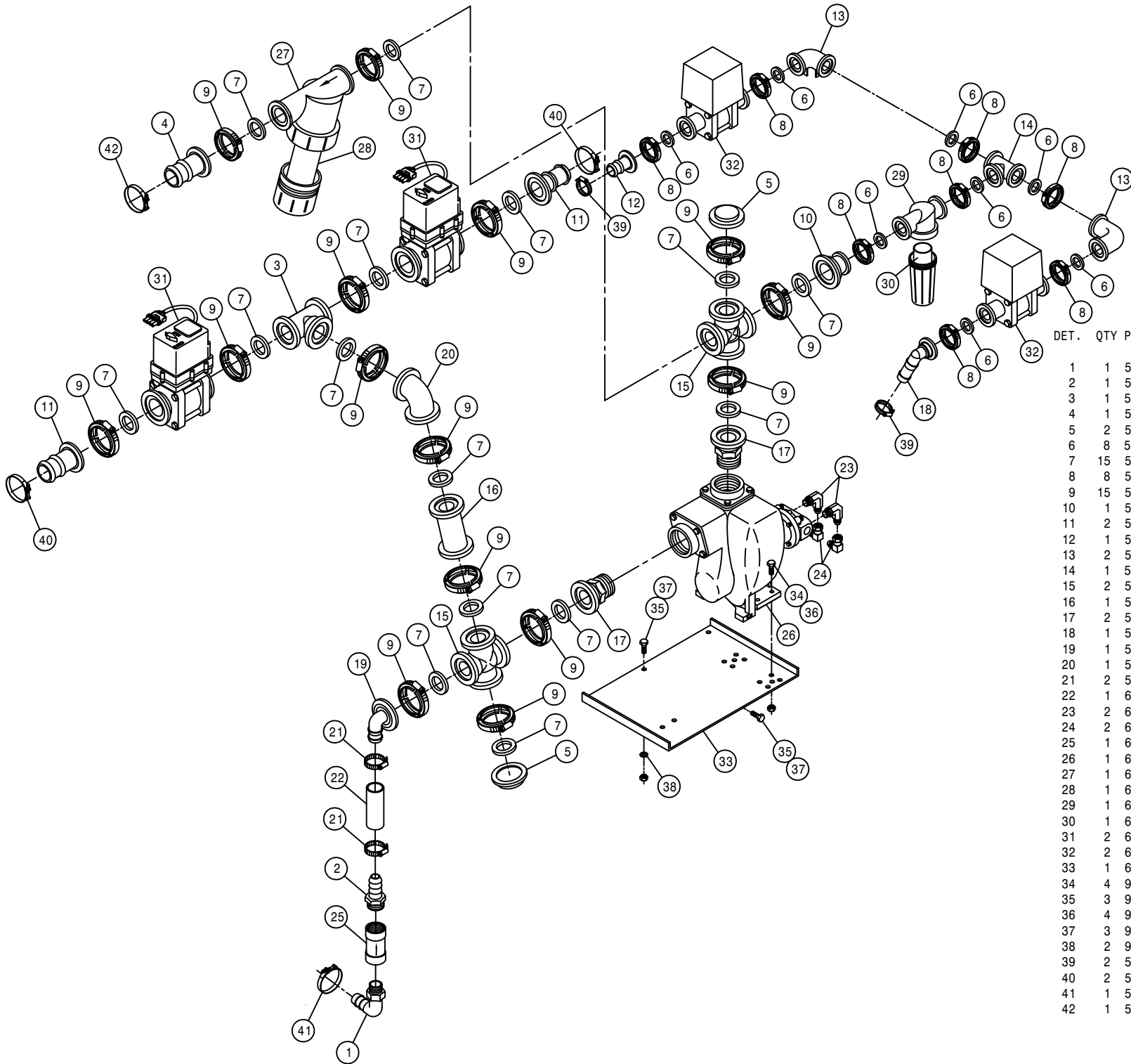

SOLUTION PUMP ASSEMBLY

DET.	QTY	PART NO.	DESCRIPTION
1	1	500024	1"NPT-90-1"HOSE BARB, POLY
2	1	500074	1"NPT-1" HOSE BARB, POLY
3	1	500151	2" FLANGE TEE POLY
4	1	500154	2" FLANGE-2" HOSE BARB POLY
5	2	500156	2" FLANGE CAP PLUG POLY
6	8	500157	1" FLANGE GASKET EPDM
7	15	500158	1 1/2" GASKET FOR 2" FLANGE
8	8	500159	1" FLANGE CLAMP, S.S.
9	15	500160	2" FLANGE CLAMP, S.S.
10	1	500161	2"FLANGE-1"FLANGE COUPLER,POLY
11	2	500162	2" FLANGE-1 1/2 HOSE BARB POLY
12	1	500170	1" FLANGE-3/4" HOSE BARB POLY
13	2	500174	1" FLANGE-90-1" FLANGE LBOPOLY
14	1	500175	1" FLANGE TEE POLY
15	2	500176	2" FLANGE CROSS POLY
16	1	500177	2" FLANGE-2" FLANGE CPLR POLY
17	2	500182	2" FLANGE-2"MNPT ADPTR S.S.
18	1	500185	1"FLANGE-90-3/4"HOSE BARB POLY
19	1	500189	2" FLANGE-90-1" HOSE BARB POLY
20	1	500225	2"FLANGE-45-2"FLANGE LBO POLY
21	2	520087	HOSE CLAMP NO 20 STAINLESS
22	1	601463	HOSE, 1 X 4 2BR BLK EPDM
23	2	618241	3/4MJIC-90-3/4MOR LBO
24	2	618609	3/4MJIC-90-3/4FJIC SWIV LBO
25	1	690488	1.00 CHECK VLV, SPRING LOADED
26	1	690552	FLOMAX 8, 2" PUMP
27	1	690628	LINE "Y" STRAINER, 2" FLANGE
28	1	690629	50 MESH SCREEN FOR 690628
29	1	690660	LINE "T" STRAINER, 1" FLANGE
30	1	690661	50 MESH SCREEN FOR 690660
31	2	696176	ELECT BALL VLV,2"FLANGE BANJO
32	2	696177	ELECT BALL VLV,1"FLANGE TJET
33	1	690530	2" SOLU PUMP MT WLD 95
34	4	900066	5/16UNC X 1 1/4 HEX BOLT
35	3	900129	3/8UNC X 1" HEX BOLT
36	4	914002	5/16UNC HEX STOVER NUT
37	3	914004	3/8UNC HEX STOVER NUT
38	2	920002	3/8 SAE FLAT WASHER
39	2	520055	HOSE CLAMP NO 12 STAINLESS
40	2	520133	1.81/2.06 T-BOLT HOSE CLAMP SS
41	1	520138	1.38/1.56 T-BOLT HOSE CLAMP
42	1	520141	2.31/2.62 T-BOLT HOSE CLAMP SS

LIFTARM ASSEMBLY

DET. QTY PART NO. DESCRIPTION

1	2	160471	LWR LIFT ARM WLD 8540-8250 87
2	1	164350	RH LIFT ARM EXT WLD, 2100 98
3	1	164351	LH LIFT ARM EXT WLD, 2100 98
4	12	160691	BUSH LIFT ARM LONG 470
5	12	470287	TUBE CLAMP, .375-.375 (PAIR)
6	1	164651	UPPER LIFT ARM WLD,284 2001
7	12	471005	1/4 28 X 1/2 GREASE ZERK
8	1	164364	RH LIFTARM V-PLT MT WLD2100 98
9	1	164365	LH LIFTARM V-PLT MT WLD2100 98
10	2	293404	FRT TURN/WARN LITE ASSY2100 98
11	1	615761	LIFT RAISE HYD TUBE ASSY
12	1	615762	LIFT LOWER HYD TUBE ASSY
13	1	615764	LEVEL LOWER HYD TUBE ASSY
14	1	615763	LEVEL RAISE HYD TUBE ASSY
15	1	615767	BOOM EXTN LOWER HYD TUBE ASSY
16	1	615766	BOOM EXTN RAISE HYD TUBE ASSY
17	1	615769	RH FOLD LOWER HYD TUBE ASSY
18	1	615768	RH FOLD RAISE HYD TUBE ASSY
19	3	914000	1/4UNC HEX STOVER NUT
20	2	621518	TRANSOM LIFT CYL ASSY
21	2	473779	10MM-1.50 HEX NUT
22	3	900013	1/4UNC X 3 3/4 HEX BOLT
23	6	619010	9/16MJIC UNION
24	4	900342	5/8UNC X 4" HEX BOLT
25	8	900343	5/8UNC X 4 1/2 HEX BOLT
26	8	900334	5/8UNC X 1 3/4 HEX BOLT
27	8	900338	5/8UNC X 3" HEX BOLT
28	28	914010	5/8UNC HEX STOVER NUT
29	2	293402	HEADLIGHT ASSY, 2100 98
30	2	470100	3/8 INT TOOTH LOCK WASHER
31	1	291669	YELLOW LENS FOR 291668
32	2	618019	9/16MJIC UNION TEE
33	2	618618	9/16MJIC-90-9/16FJIC SWIV LBO
34	2	470356	MTG CLIP, PACKARD CONNECTOR

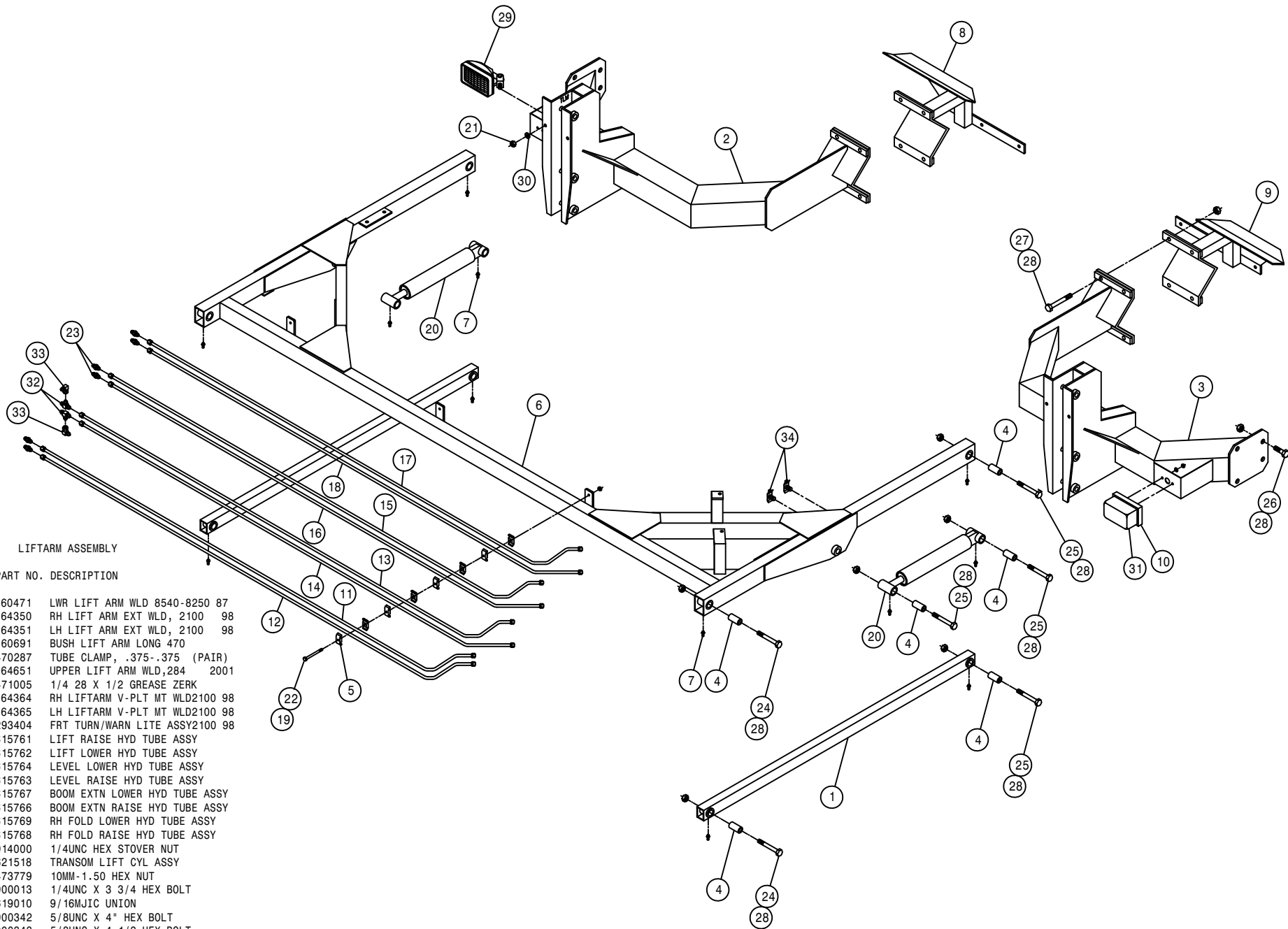

TRANSOM ASSEMBLY

DET. QTY PART NO. DESCRIPTION

1	2	160429	FEEDER HOSE SUPPORT SPRING MT
2	2	160691	BUSH LIFT ARM LONG 470
3	2	164123	NOZL MT TUBE, 254/284 96
4	2	164125	NOZL MT TUBE HANGER CHAN 96
5	2	164823	BRKAWAY PIVOT BUSH,DTS 8/10 05
6	2	164128	LEVEL CYL PIVOT BRKT WLD 96
7	2	164824	BOOM BREAKAWAY WLD,284/2101 05
8	2	900848	5/8UNC X 4 3/4 HEX BOLT GR8
9	2	470136	3/8UNC-3 1/16ID-3 SQ U-BOLT
10	4	164264	5/8UNC X 3" EYE BOLT
11	6	471005	1/4 28 X 1/2 GREASE ZERK
12	4	473973	.31UNC-1.31ID-2.0 SQ U-BOLT SS
13	2	900852	1" UNC-4 3/4 HHCS,1 1/4THD GR8
14	4	910010	5/8UNC HEX NUT
15	8	914002	5/16UNC HEX STOVER NUT
16	4	914004	3/8UNC HEX STOVER NUT
17	1	164820	TRANSOM WLD, DTS 8/DTS 10 05
18	12	914010	5/8UNC HEX STOVER NUT
19	4	920005	5/8 SAE FLAT WASHER
20	4	483032	1 1/2 X 1" X .134TH MACH WASH
21	2	164830	BOOM PIVOT PIN,1.00 X 13.31 05
22	4	470117	COTTER PIN 3/16 1 3/4 SQ CUT
23	2	482000	SPRING, .930D X 8.5LG, .072WIRE
24	2	520126	CUSH HOSE CLAMP 2IN X 5/8W
25	2	621522	BOOM LEVEL CYL ASSY
26	2	621520	BOOM HINGE FOLD CYL ASSY
27	4	900829	5/8UNC X 4" HEX BOLT GR8
28	2	900844	5/8UNC X 2 3/4 HEX BOLT GR8
29	2	471023	GREASE ZERK 1/4-28 X 45
30	4	520099	HOSE CLAMP NO 40 STAINLESS
31	2	621211	ACCUMULATOR CYL ASSY,60 BOOM
32	2	621212	ACCUMULATOR CYL ASSY,80/90BOOM
33	4	629735	CAPLUG, 1 1/4" SQ, BLACK POLY
34	2	470118	1/4UNC X 3/4 FLANGE HEX BOLT
35	2	470121	1/4UNC HEX FLANGE LOCK NUT
36	2	914016	1" UNC HEX STOVER NUT

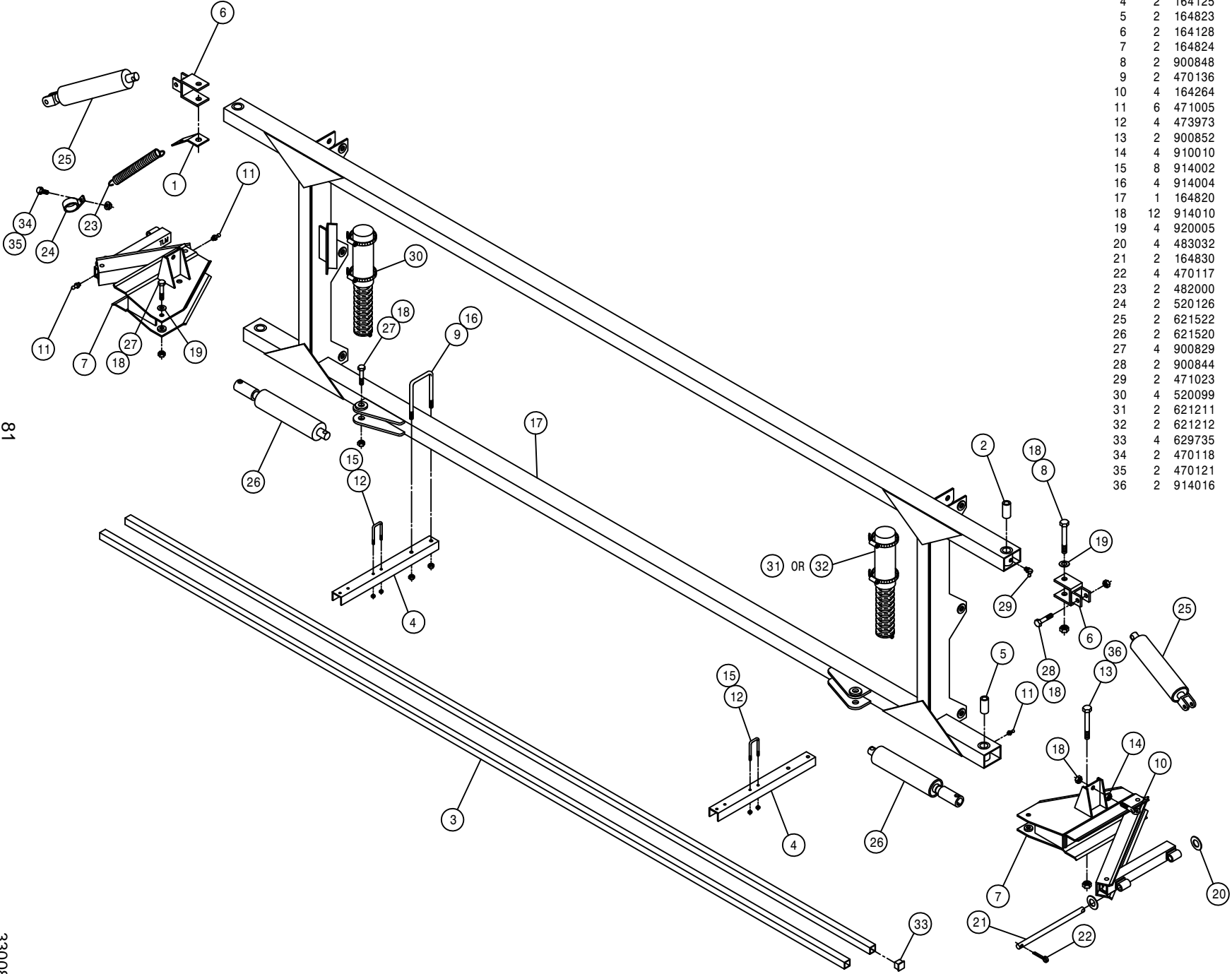

BOOM CONTROL VALVE ASSEMBLY

DET. QTY PART NO. DESCRIPTION

1	2	192514	1.00 ID CORRGTD LOOM, BLK POLY
2	16	291621	PACKARD CONNECT CAVITY PLUG
3	2	291746	PACKARD CONNECT, 22WIRE TOWER
4	4	291747	PACKARD CONNECTOR COMB, 22WIRE
5	2	342827	HARNESS CONNECTOR BRKT, 2101 03
6	8	470121	1/4UNC HEX FLANGE LOCK NUT
7	1	605615	HYD FILTER, INLINE 25M 9/16FOR
8	1	606104	BOOM CTRL VLV, STS PWRSYS 03
9	1	618115	9/16MJIC-90-3/4MOR LBO
10	5	618119	9/16MJIC-90-9/16MOR LBO
11	5	618126	9/16MJIC-9/16MOR ADPTR
12	1	618241	3/4MJIC-90-3/4MOR LBO
13	3	618444	9/16MOR RUN TEE-9/16MJIC
14	2	618618	9/16MJIC-90-9/16FJIC SWIV LBO
15	1	618692	3/4FJIC SWIV-9/16MOR ADPTR
16	1	605616	ELEMENT, 25M HYD FILTER 605615
17	1	605617	SPRING KIT, HYD FILTER 605615
18	2	900146	3/8UNC X 5 3/4 HEX BOLT
19	2	914004	3/8UNC HEX STOVER NUT
20	4	470118	1/4UNC X 3/4 FLANGE HEX BOLT
21	1	618486	9/16FJIC SW RUN TEE-9/16MJIC
22	2	614763	9/16MJIC-9/16MOR, .042 CHK ADPT

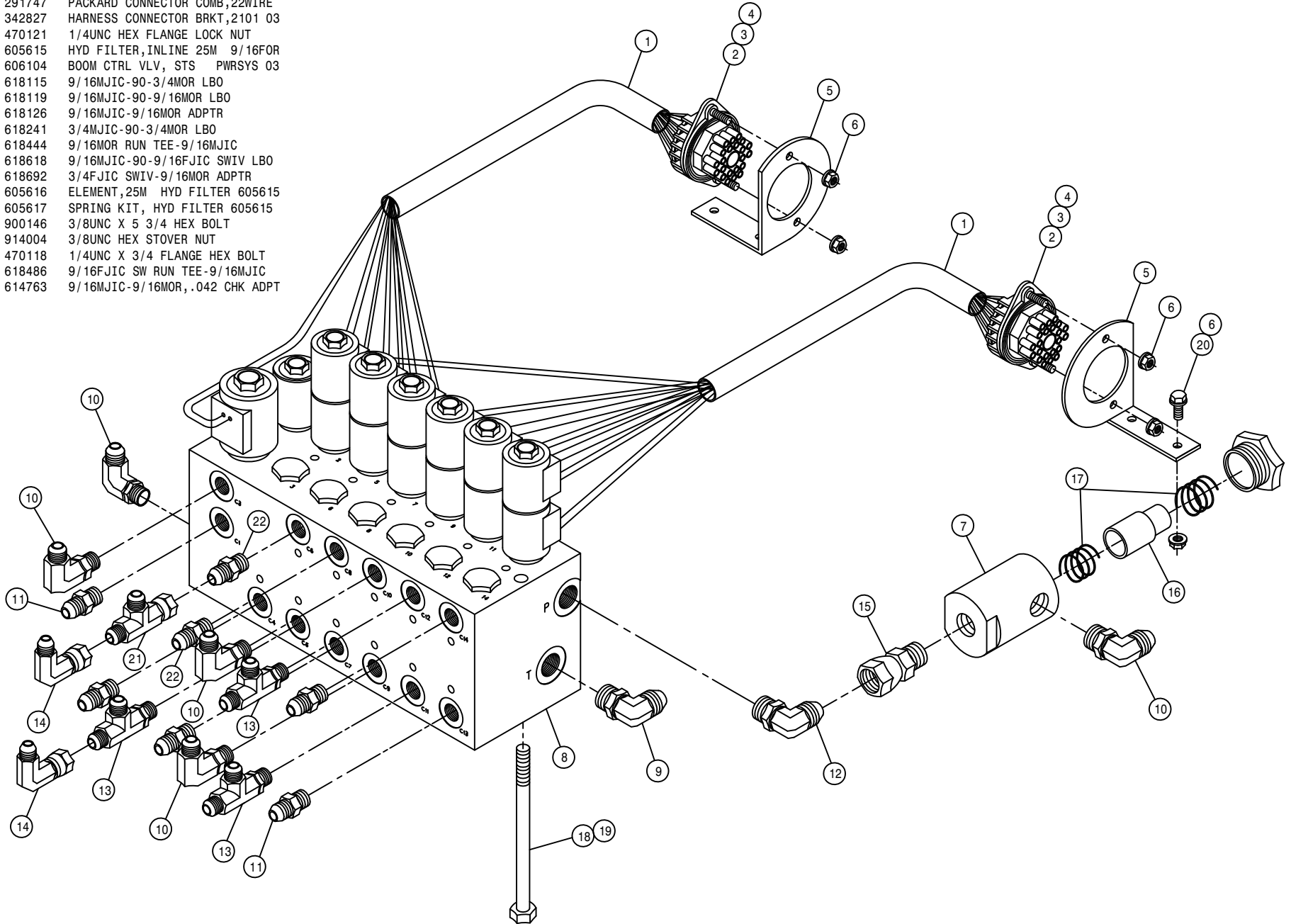

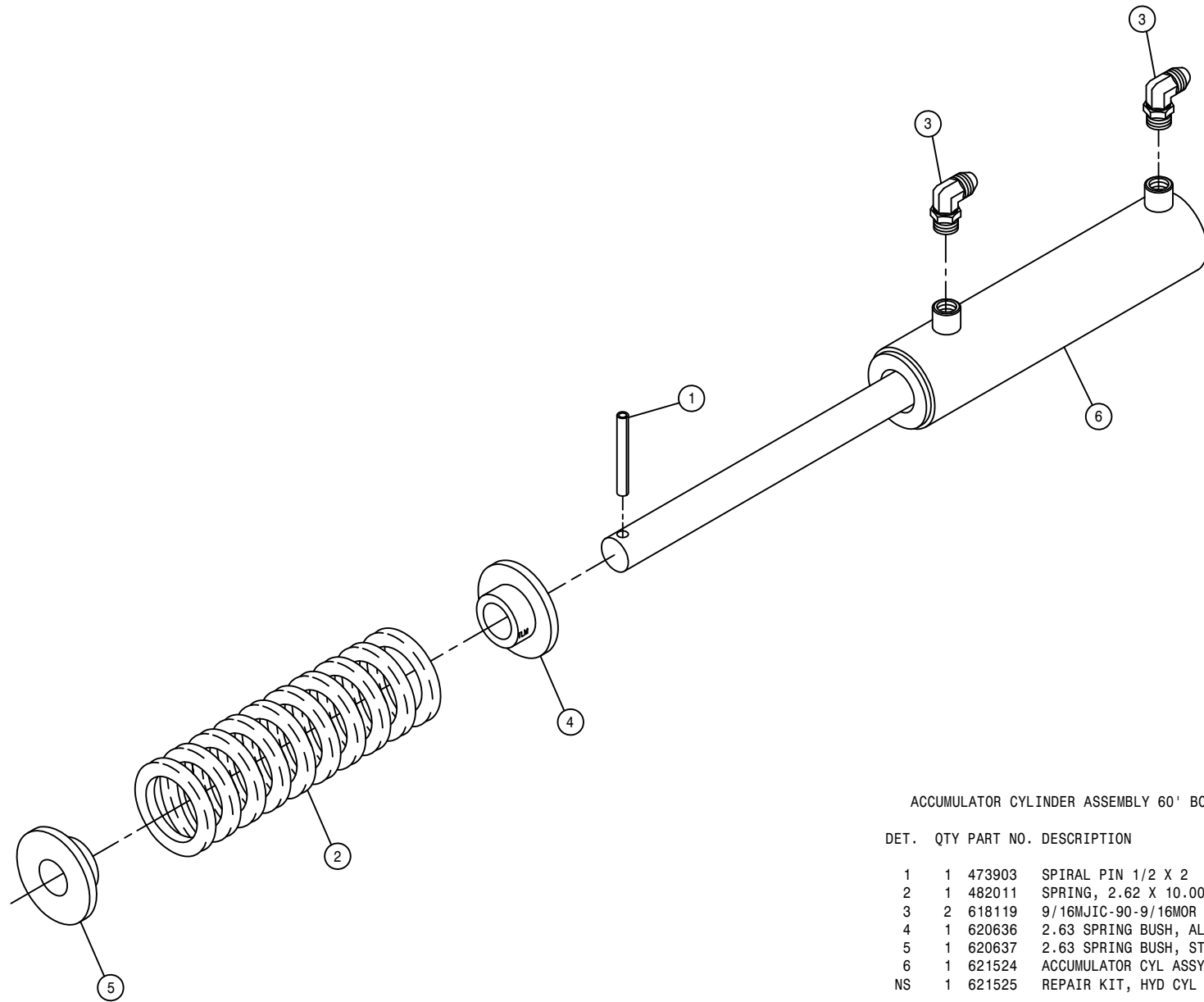

ACCUMULATOR CYLINDER ASSEMBLY 60' BOOM

DET.	QTY	PART NO.	DESCRIPTION	
	1	473903	SPIRAL PIN 1/2 X 2	640
	1	482011	SPRING, 2.62 X 10.00 COMPRSN	
	2	618119	9/16MJC-90-9/16MOR LBO	
	4	620636	2.63 SPRING BUSH, ALUM	96
	5	620637	2.63 SPRING BUSH, STEEL	96
	6	621524	ACCUMULATOR CYL ASSY	
NS	1	621525	REPAIR KIT, HYD CYL 621524	

NOTE: 621211 - ACCUMULATOR CYLINDER ASSEMBLY

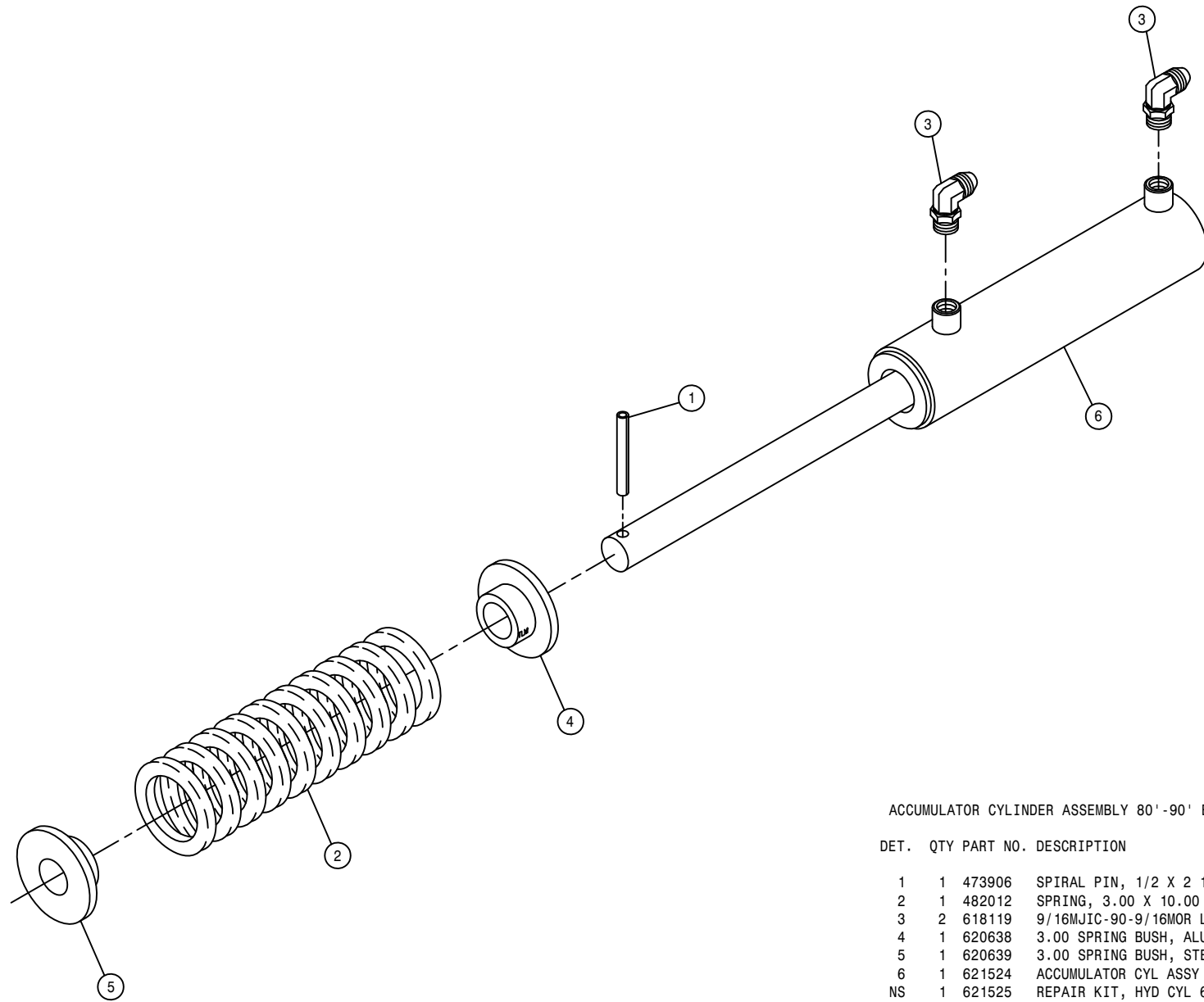

ACCUMULATOR CYLINDER ASSEMBLY 80' -90' BOOM

DET. QTY PART NO. DESCRIPTION

1	1	473906	SPIRAL PIN, 1/2 X 2 1/2 LG	
2	1	482012	SPRING, 3.00 X 10.00 COMPRSN	
3	2	618119	9/16MJIC-90-9/16MOR LBO	
4	1	620638	3.00 SPRING BUSH, ALUM	96
5	1	620639	3.00 SPRING BUSH, STEEL	96
6	1	621524	ACCUMULATOR CYL ASSY	
NS	1	621525	REPAIR KIT, HYD CYL 621524	

NOTE: 621212 - ACCUMULATOR CYLINDER ASSEMBLY

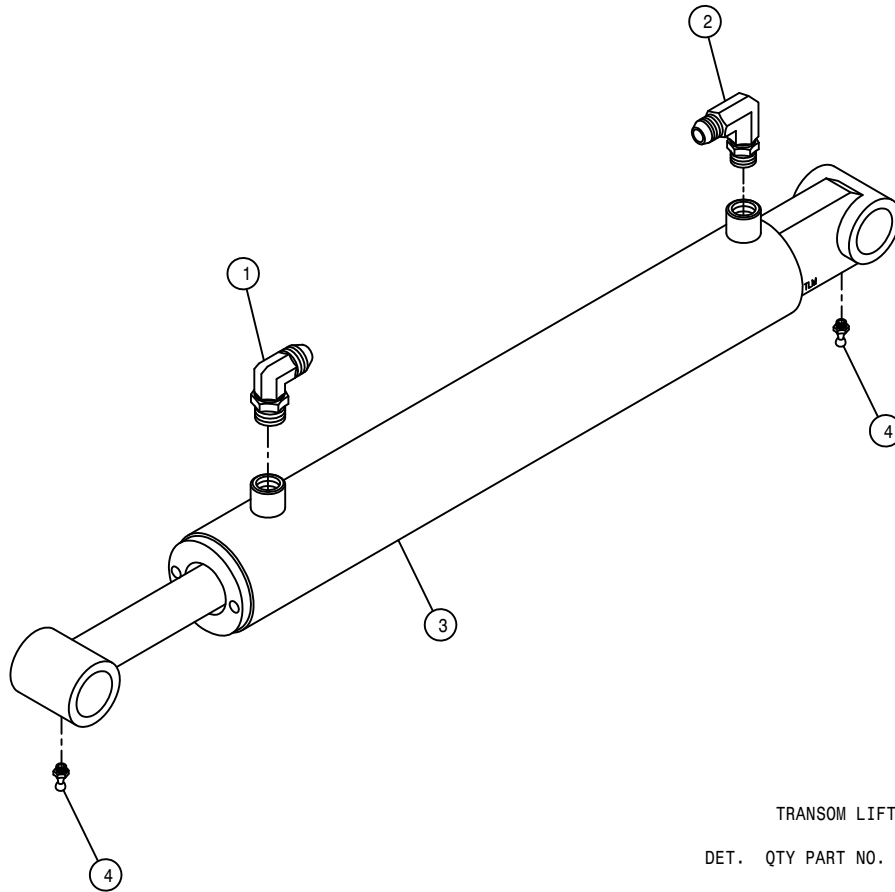

TRANSOM LIFT CYLINDER ASSEMBLY

DET.	QTY	PART NO.	DESCRIPTION
	1	618119	9/16MJIC-90-9/16MOR LBO
	1	618689	9/16MOR-90-9/16MJ .042 CHK VLV
	1	621518	TRANSOM LIFT CYL ASSY
	2	471005	1/4 28 X 1/2 GREASE ZERK
	1	621519	REPAIR KIT, HYD CYL 621518

NOTE: 621207 - TRANSOM LIFT CYLINDER ASSEMBLY WITH FITTINGS

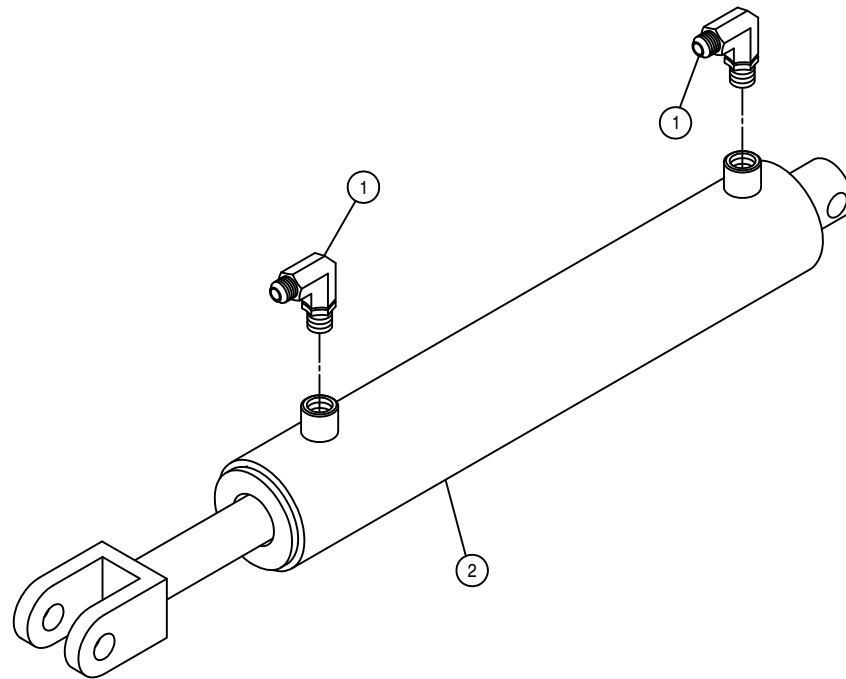

BOOM LEVEL CYLINDER ASSEMBLY

DET. QTY PART NO. DESCRIPTION

1	2	618119	9/16MJIC-90-9/16MOR LBO
2	1	621522	BOOM LEVEL CYL ASSY
NS	1	621523	REPAIR KIT, HYD CYL 621522

NOTE: 621210 - BOOM LEVEL CYLINDER ASSEMBLY WITH FITTINGS

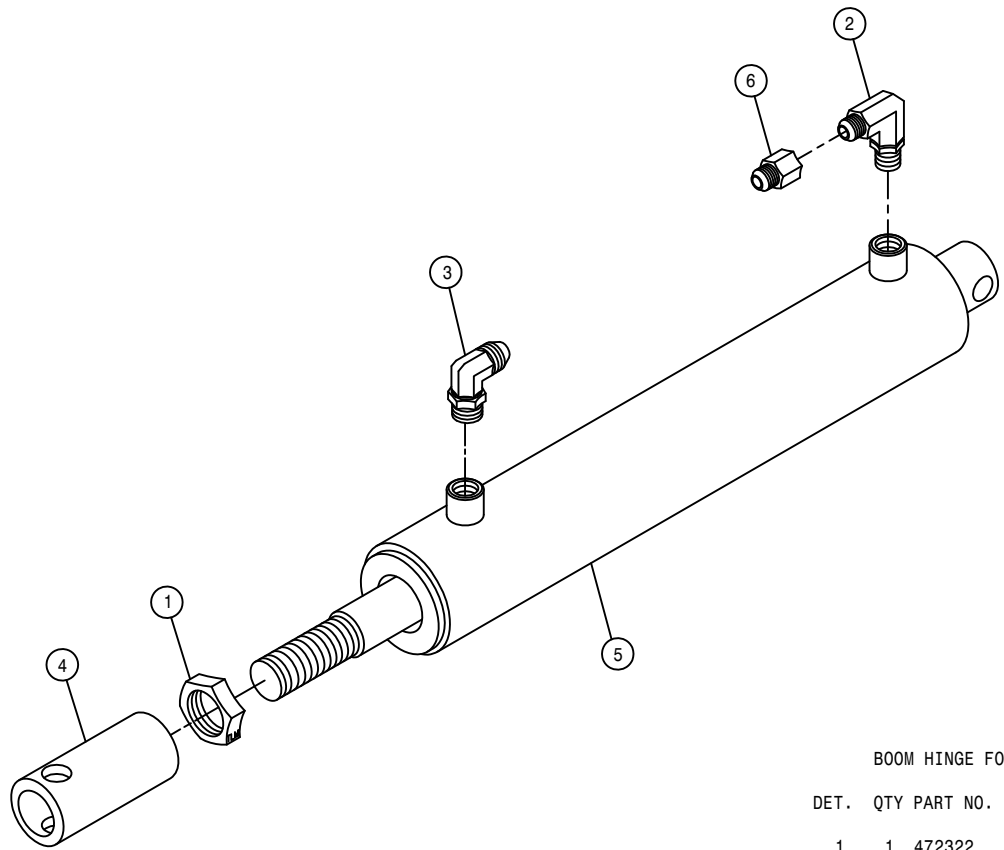

BOOM HINGE FOLD CYLINDER ASSEMBLY

DET.	QTY	PART NO.	DESCRIPTION
	1	472322	7/8-14 UNF HEX JAM NUT
	1	618119	9/16MJIC-90-9/16MOR LBO
	1	618688	9/16MOR-90-9/16MJ .025 CHK VLV
	1	620653	FOLD CYL ADJ SLEEVE 97
	1	621520	BOOM HINGE FOLD CYL ASSY
	1	618733	9/16JIC .042 ORIFICE ADPTR
NS	1	621521	REPAIR KIT, HYD CYL 621520

NOTE: 621208 - BOOM HINGE FOLD CYLINDER ASSEMBLY WITH FITTINGS

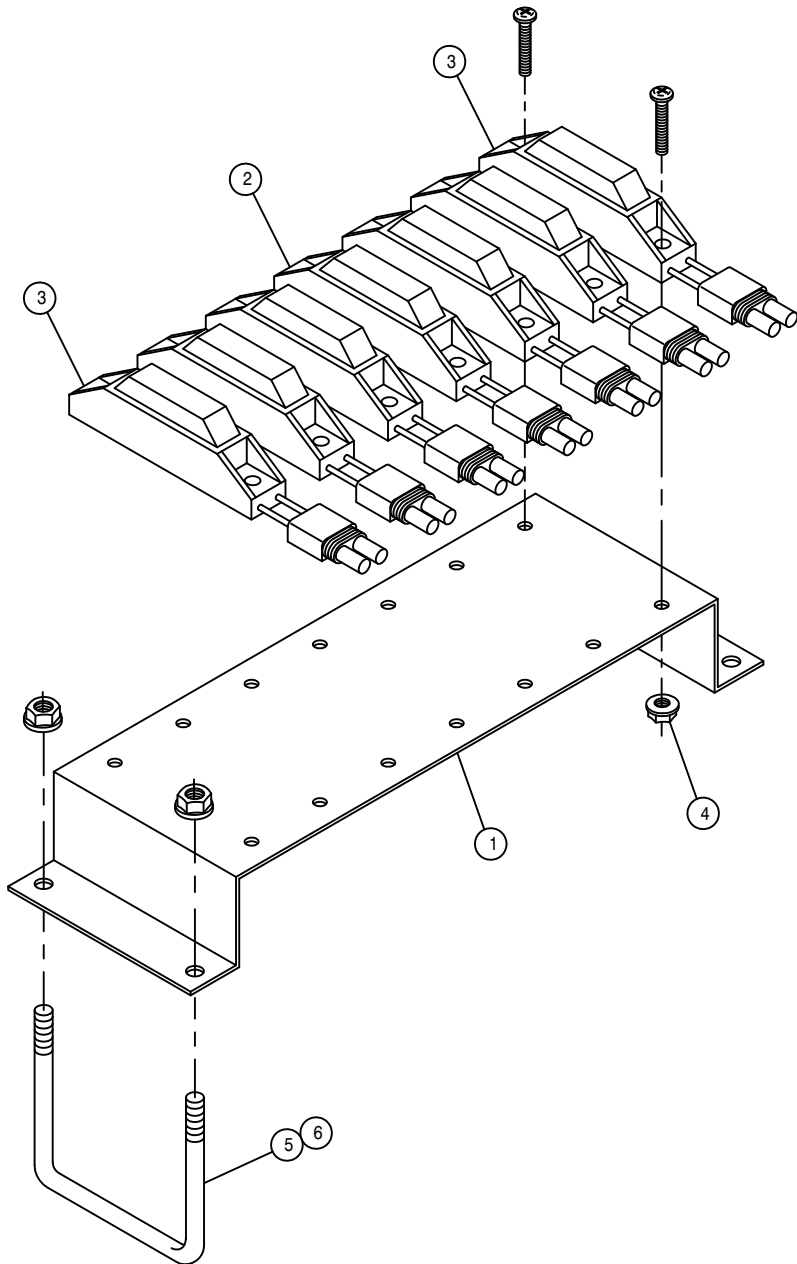

BOOM SECTION LIGHT ASSEMBLY

DET. QTY PART NO. DESCRIPTION

1	1	164386	BOOM SECT ID LIGHT BRKT2100 98
2	5	293396	RED BOOM SECT ID LIGHT ASSY
3	2	293397	YELLOW BOOM SECT ID LIGHT ASSY
4	14	470175	10-32 HEX FLANGE LOCK NUT
5	2	473970	1/4UNC-1 1/16ID-2 3/4 U-BOLTSQ
6	4	470121	1/4UNC HEX FLANGE LOCK NUT

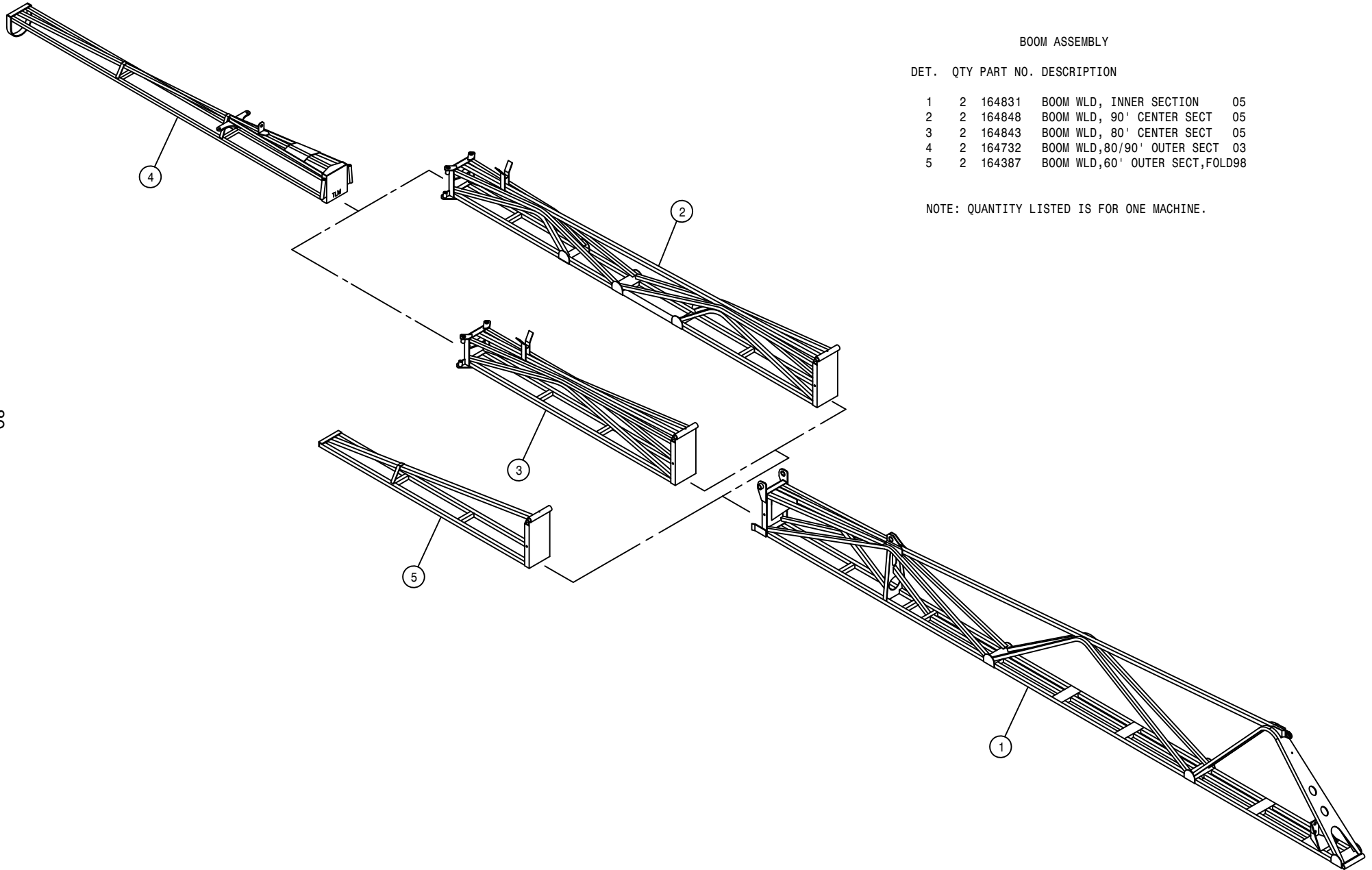

BOOM ASSEMBLY

DET.	QTY	PART NO.	DESCRIPTION	
1	2	164831	BOOM WLD, INNER SECTION	05
2	2	164848	BOOM WLD, 90' CENTER SECT	05
3	2	164843	BOOM WLD, 80' CENTER SECT	05
4	2	164732	BOOM WLD,80/90' OUTER SECT	03
5	2	164387	BOOM WLD,60' OUTER SECT,FOLD98	

NOTE: QUANTITY LISTED IS FOR ONE MACHINE.

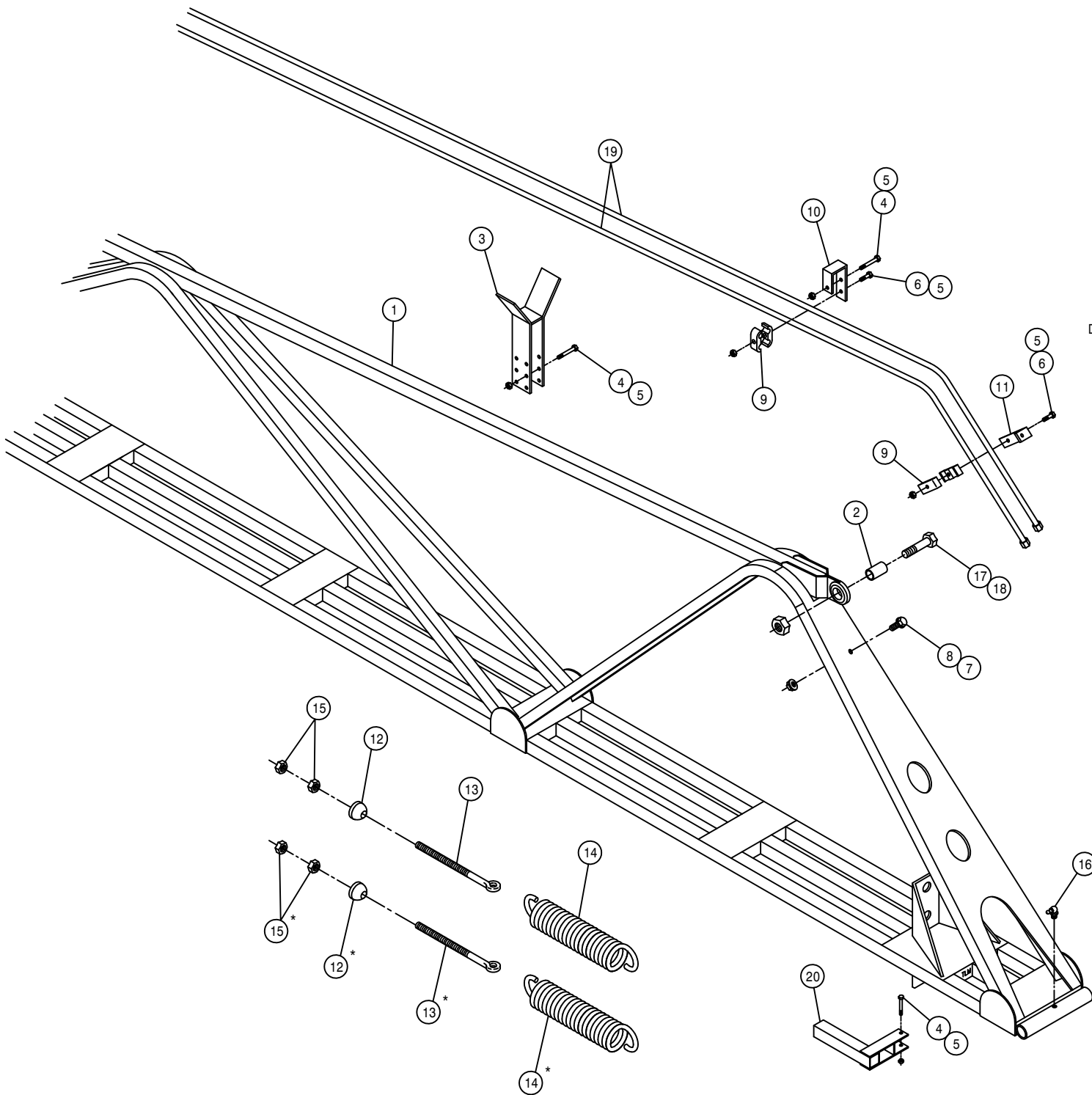

INNER BOOM ASSEMBLY

DET.	QTY	PART NO.	DESCRIPTION	
1	2	164831	BOOM WLD, INNER SECTION	05
2	2	164227	BOOM BALL JOINT BUSH	96
3	2	164266	OUTER BOOM SUPP WLD,80/90'	96
4	18	900007	1/4UNC X 2" HEX BOLT	
5	28	914000	1/4UNC HEX STOVER NUT	
6	10	900004	1/4UNC X 1 1/4 HEX BOLT	
7	2	470121	1/4UNC HEX FLANGE LOCK NUT	
8	2	470118	1/4UNC X 3/4 FLANGE HEX BOLT	
9	10	470287	TUBE CLAMP, .375-.375 (PAIR)	
10	8	164242	HYD TUBE HANGER CLEVIS,BOOM96	
11	2	164243	HYD TUBE HANGER ANGLE,BOOM 96	
12	4	164263	SWIVEL, 5/8 BOOM EYEBOLT	
13	4	164265	5/8UNC X 7 1/2 EYE BOLT	
14	4	482014	SPRING,3.25 X 11.50 EXTENSION	
15	8	910010	5/8UNC HEX NUT	
16	2	471028	GREASE ZERK, 1/4-28 90DEG	
17	2	900844	5/8UNC X 2 3/4 HEX BOLT GR8	
18	2	914010	5/8UNC HEX STOVER NUT	
19	4	615684	HYD TUBE ASSY,BOOM EXT FOLD96	
20	2	164275	NOZL MT WLD	96

NOTE: QUANTITY LISTED IS FOR ONE MACHINE.
 *60 FOOT BOOM USES ONE SPRING SETUP.

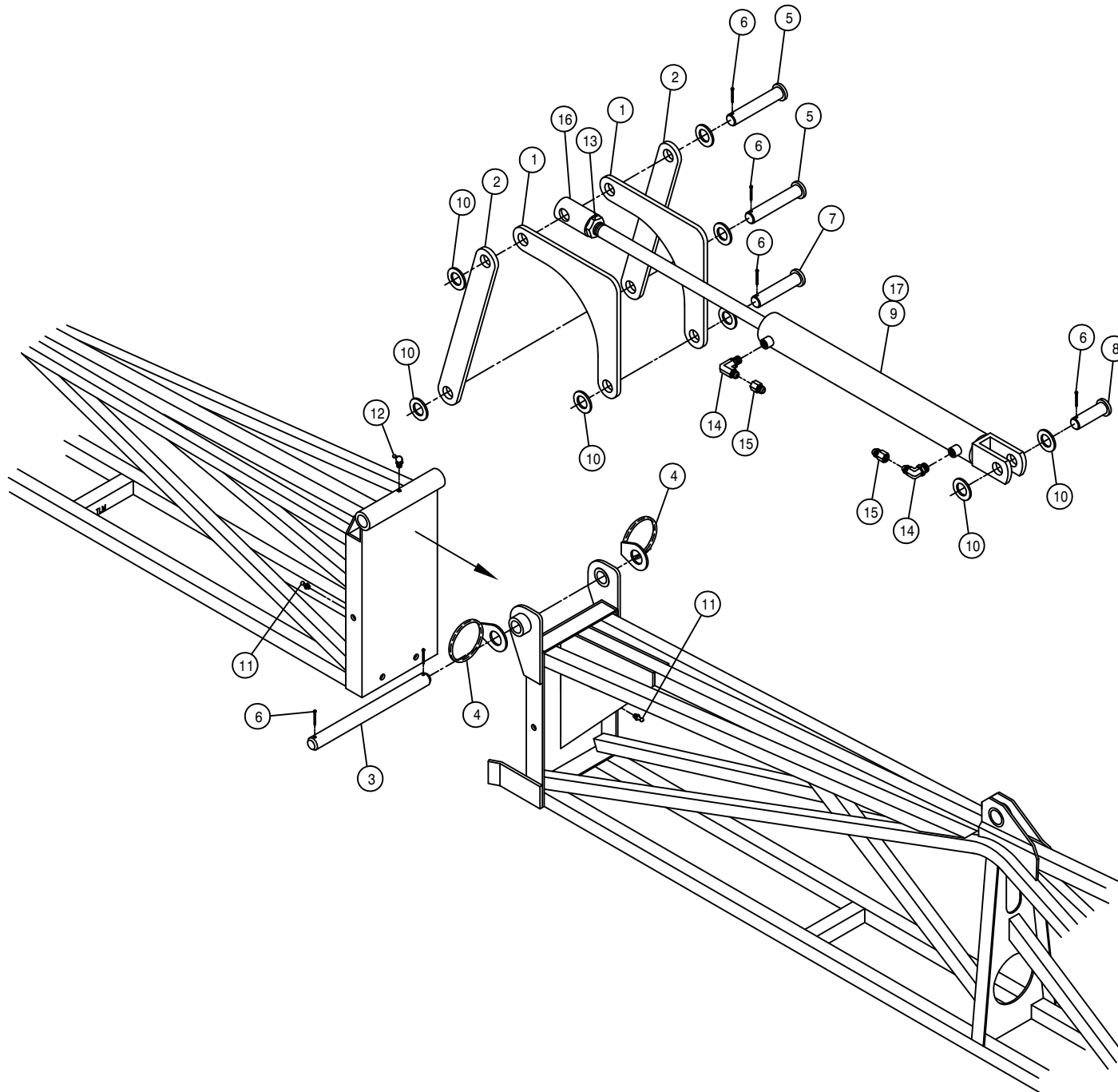

80' -90' BOOM HINGE PIVOT ASSEMBLY

DET.	QTY	PART NO.	DESCRIPTION
	1	4	164228 FOLDING LINK, INNER BOOM 96
	2	4	164229 FOLDING LINK, BOOM CNTR SECT96
	3	2	164231 BOOM PIN, 1.00 X 11.75 96
	4	4	438302 HOSE SUPPORT RING WLD
	5	4	470155 CLEVIS PIN, 1.00 X 4.00 PLT
	6	12	470162 COTTER PIN 3/16 X 1 1/2 SQ CUT
	7	2	472012 CLEVIS PIN, 1.00 X 3.25 PLT
	8	2	472270 CLEVIS PIN, 1.00 X 2.50 PLT
	9	2	621526 BOOM CNTR SECT CYL ASSY(12T)
	10	16	920008 1" SAE FLAT WASHER
	11	4	471005 1/4 28 X 1/2 GREASE ZERK
	12	2	471028 GREASE ZERK, 1/4-28 90DEG
	13	2	472328 1"-12 HEX JAM NUT
	14	4	618119 9/16MJIC-90-9/16MOR LBO
	15	4	618733 9/16JIC .042 ORIFICE ADPTR
	16	2	620681 CENTER FOLD CYL ADJ SLEEVE 12T
	17	2	621527 REPAIR KIT, HYD CYL 621526

NOTE: QUANTITY LISTED IS FOR ONE MACHINE.

80'-90' OUTER BOOM HINGE ASSEMBLY

DET. QTY PART NO. DESCRIPTION

1	2	160351	BOOM PIVOT PIN, .625 X 11.50
2	2	160979	1/2UNC X 9" EYE BOLT
3	2	160981	SWIVEL, 1/2" BOOM EYEBOLT
4	2	164732	BOOM WLD,80/90' OUTER SECT 03
5	2	164734	CYL MT ARM WLD,80/90 CNTR SECT
6	2	164737	BOOM SPRING PIN WLD 03
7	2	164666	OUTER BOOM SUPPORT WLD 00
8	6	470162	COTTER PIN 3/16 X 1 1/2 SQCUT
9	2	482013	SPRING,2.50 X 17.00 EXTENSION
10	8	900007	1/4UNC X 2" HEX BOLT
11	4	910008	1/2UNC HEX NUT
12	8	914000	1/4UNC HEX STOVER NUT
13	4	920005	5/8 SAE FLAT WASHER
14	2	471005	1/4 28 X 1/2 GREASE ZERK
15	2	473895	1/4 X 1 3/4 LINCHPIN
16	2	621554	LADR/SF/BRKWAY CYL,1.50 X12.25
17	2	616042	04C1T-06FJX-06FJX-13 H/A
18	2	618119	9/16MJIC-90-9/16MOR LBO
19	2	618689	9/16MOR-90-9/16MJ .042 CHK VLV
20	6	900266	1/2UNC X 1 3/4 HEX BOLT
21	8	914008	1/2UNC HEX STOVER NUT
22	2	900267	1/2UNC X 2" HEX BOLT
23	2	621555	REPAIR KIT,HYD CYL 621554
24	2	470098	RUBBER BUMPER 2.500D X .38ID
25	2	483043	3/8 REGULAR FLAT WASHER
26	1	900131	3/8UNC X 1 1/2 HEX BOLT
27	1	914004	3/8UNC HEX STOVER NUT

NOTE: 1. QUANTITY LISTED IS FOR ONE MACHINE.
 2. PARTS MARKED WITH (*) ARE USED ON THE LH SIDE OF THE 90' BOOM OPTION.

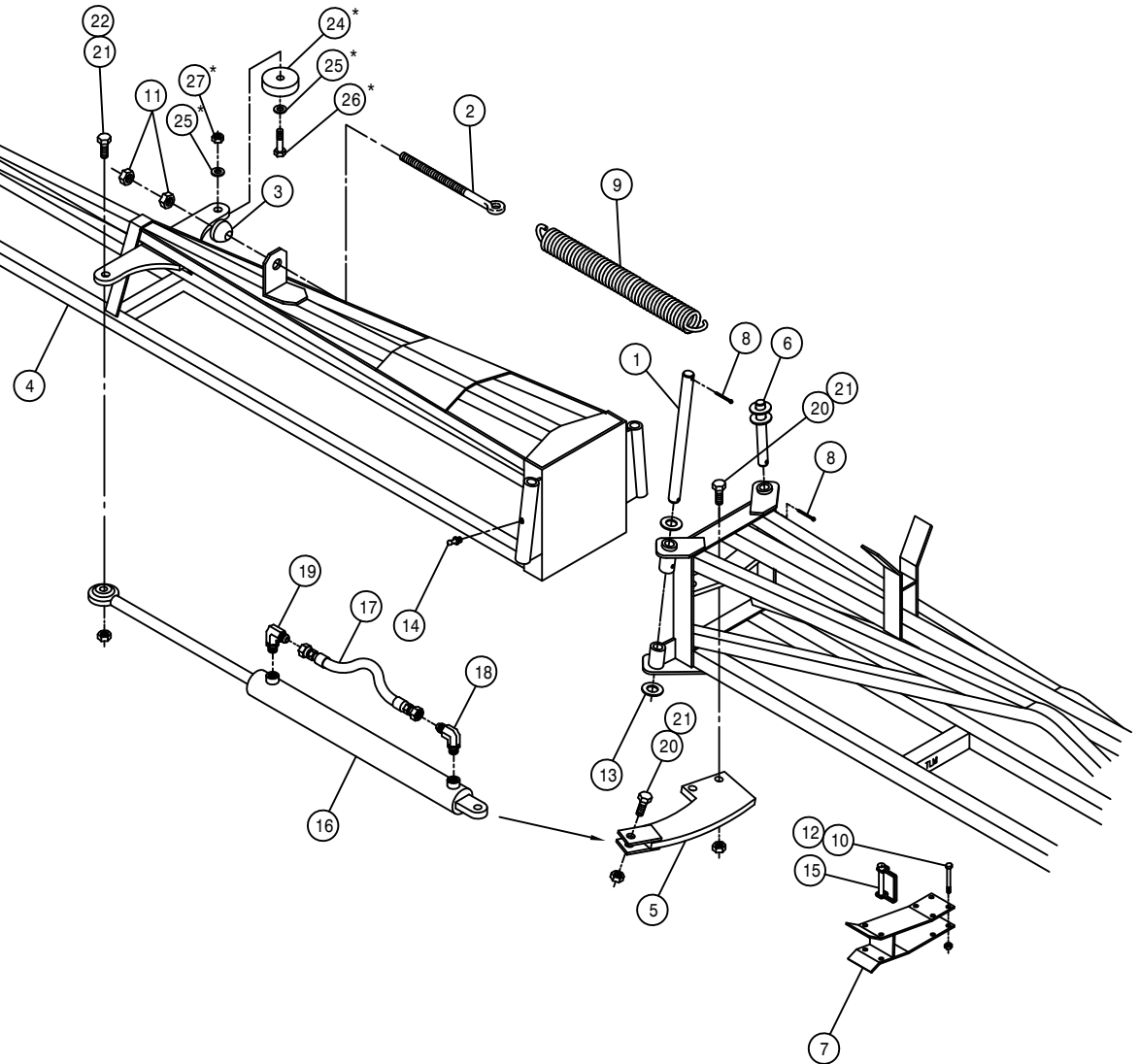

60' BOOM HINGE PIVOT ASSEMBLY

DET. QTY PART NO. DESCRIPTION

1	2	164387	BOOM WLD,60' OUTER SECT,FOLD98
2	2	164231	BOOM PIN, 1.00 X 11.75 96
3	12	470162	COTTER PIN 3/16 X 1 1/2 SQCUT
4	2	164388	OUTER BOOM SUPP WLD,60'FOLD 98
5	4	900007	1/4UNC X 2" HEX BOLT
6	4	914000	1/4UNC HEX STOVER NUT
7	4	438302	HOSE SUPPORT RING WLD
8	4	471005	1/4 28 X 1/2 GREASE ZERK
9	2	471028	GREASE ZERK, 1/4-28 90DEG
10	4	164228	FOLDING LINK, INNER BOOM 96
11	4	164229	FOLDING LINK,BOOM CNTR SECT96
12	4	470155	CLEVIS PIN, 1.00 X 4.00 PLT
13	2	472012	CLEVIS PIN, 1.00 X 3.25 PLT
14	2	472270	CLEVIS PIN, 1.00 X 2.50 PLT
15	2	621526	BOOM CNTR SECT CYL ASSY(12T)
16	16	920008	1" SAE FLAT WASHER
17	2	472328	1"-12 HEX JAM NUT
18	4	618119	9/16MJIC-90-9/16MOR LBO
19	4	618733	9/16JIC .042 ORIFICE ADPTR
20	2	620681	CENTER FOLD CYL ADJ SLEEVE 12T
21	2	621527	REPAIR KIT, HYD CYL 621526

NOTE: QUANTITY LISTED IS FOR ONE MACHINE.

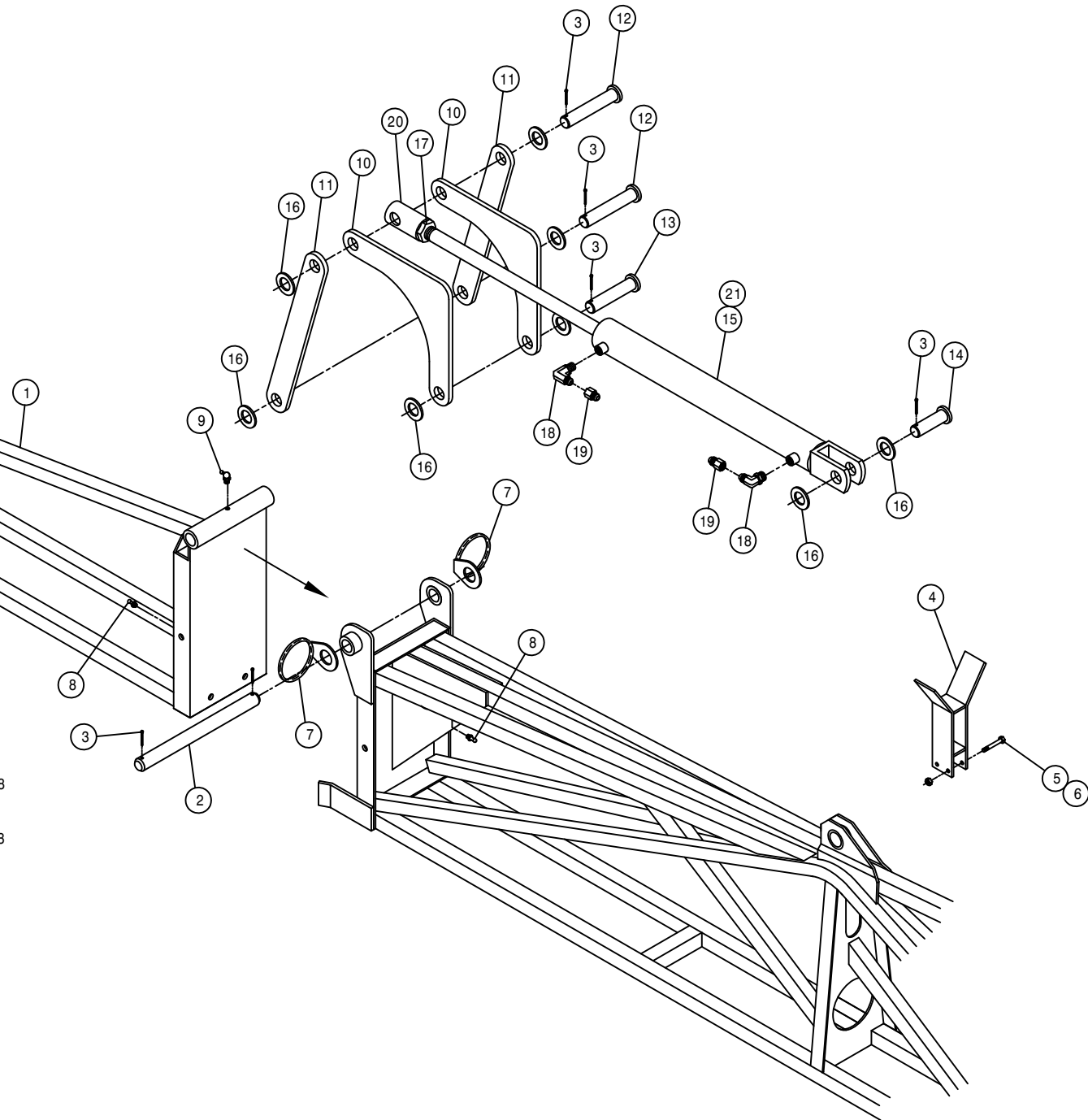

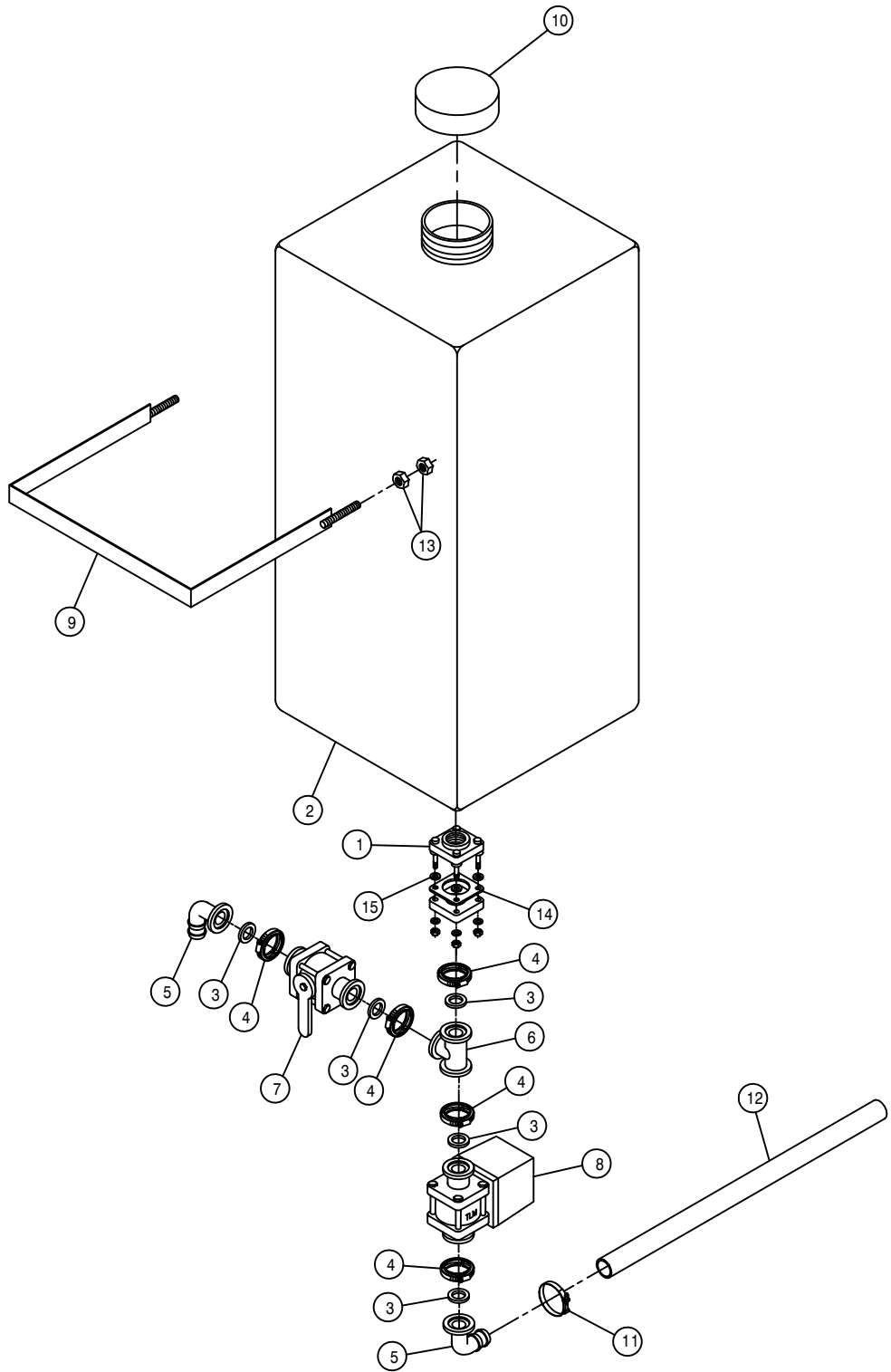

RINSE TANK ASSEMBLY

DET. QTY PART NO. DESCRIPTION

1	1	500178	1"FLG TANK FTG,BOTDRN BLT POLY
2	1	763475	55 GAL TANK, RECTANGLE VERTICL
3	5	500157	1" FLANGE GASKET EPDM
4	5	500159	1" FLANGE CLAMP, S.S.
5	2	500173	1" FLANGE-90-1" HOSE BARB POLY
6	1	500175	1" FLANGE TEE POLY
7	1	696147	BALL VLV, 1" FLANGE
8	1	696177	ELECT BALL VLV,1"FLANGE TJET
9	1	342621	RINSE TANK BAND WLD, 2100 98
10	1	763474	LID, 55 GAL RINSE TANK 763475
11	1	520138	1.38/1.56 T-BOLT HOSE CLAMP
12	1	601425	HOSE, 1 X 192 2F-1W EPDM
13	4	910008	1/2UNC HEX NUT
14	1	500221	FULL GASKET,1" TANK FTG 500178
15	4	500222	FOOT GASKET,1" TANK FTG 500178

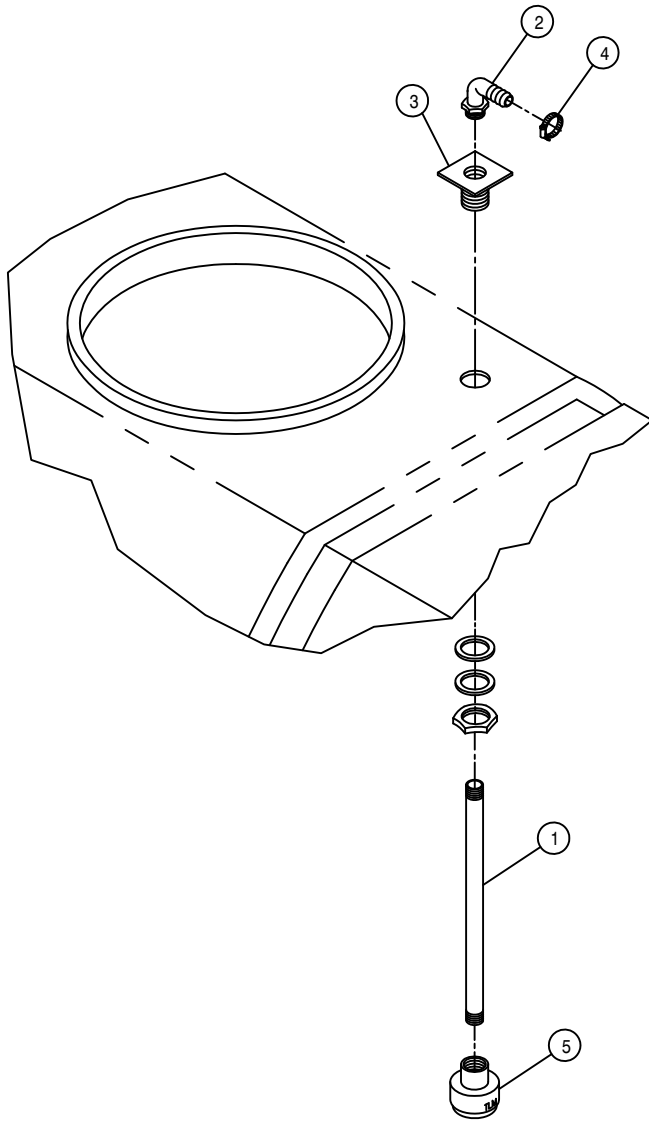

RINSE NOZZLE ASSEMBLY

DET. QTY PART NO. DESCRIPTION

1	1	504850	CPVC PIPE NIPPLE .75NPT-24.00
2	2	500054	3/4NPT-90-3/4 HOSE BARB, POLY
3	2	618549	.75 PLASTIC FTG ASSY POLY TNK
4	2	520055	HOSE CLAMP NO 12 STAINLESS
5	2	737873	ROTARY NOZZLE, TEFLON

NOTE: QUANTITY LISTED IS FOR ONE MACHINE.

FOAM MARKER TANK ASSEMBLY

NOTE: 1. DETAIL 28 AND 29 ARE USED WITH THE 60 FT BOOM.
 2. DETAIL 30 AND 31 ARE USED WITH THE 80 FT BOOM.
 3. DETAIL 32 AND 33 ARE USED WITH THE 90 FT BOOM.

DET. QTY PART NO. DESCRIPTION

1	2	500043	3/4NPT PIPE PLUG, POLY
2	2	701214	1/2NPT-90-3/4HBARB,1/4TAP,POLY
3	1	507728	REDU BUSH 1/2MNPT X 1/4FNPT,SS
4	1	505205	BLK PIPE NIPPLE 1.00NPT-5.00
5	1	505211	3/8-1/4NPT REDU BUSH, BRS
6	3	520120	HOSE CLAMP NO 4 STAINLESS
7	1	601419	HOSE, 3/8 X 30 CLEAR VINYL
8	1	601420	HOSE, 3/8 X 48 CLEAR VINYL
9	1	618571	1/4MNPT-90-1/4MNPT LBO
10	1	695900	BALL VALVE 1IN FNPT POLY
11	2	696120	BALL VALVE, 1/4NPT, STEEL
12	1	696134	BALL VALVE 2IN FNPT POLY
13	2	696181	3/4" ELECT SOLU SOLE VALVE 02
14	1	701143	FOAMER AIR TUBE FTG
15	1	701112	FOAM MARKER TANK, 36 GAL SS
16	1	711049	1/4 NYL TUBE-1/4MNPT FTG
17	1	711052	1/4"NPT CHECK VALVE,SWING,2600
18	1	783304	1/4 NPT X 3/8 HOSE BARB, BRS
19	4	193002	SPIRAL PROTECTIVE WRAP, BLACK
20	2	342333	NYL HOSE SLEEVE,2.64ID X 12.00
21	4	342623	FOAMER TANK BAND WLD, 2100 98
22	2	500069	3/4-90-3/4 HOSE BARB, POLY
23	6	520055	HOSE CLAMP NO 12 STAINLESS
24	2	900138	3/8UNC X 3 1/2 HEX BOLT
25	6	914004	3/8UNC HEX STOVER NUT
26	2	920002	3/8 SAE FLAT WASHER
27	2	195908	HOSE 3/4ID-1/8W CLEAR VINYL X 275.00
28	1	195908	HOSE 3/4ID-1/8W CLEAR VINYL X 580.00
29	1	195908	HOSE 3/4ID-1/8W CLEAR VINYL X 684.00
30	1	195908	HOSE 3/4ID-1/8W CLEAR VINYL X 780.00
31	1	195908	HOSE 3/4ID-1/8W CLEAR VINYL X 804.00
32	1	195908	HOSE 3/4ID-1/8W CLEAR VINYL X 840.00
33	1	195908	HOSE 3/4ID-1/8W CLEAR VINYL X 864.00
34	1	601592	HOSE, 1/4 X 72 AIR
35	1	507021	SS PIPE NIPPLE, 1/8NPT X 6"
36	1	500223	SS PIPE CPLG, 1/8NPT
37	1	701144	FOAMER AIR NOZZLE
38	1	342658	FOAMER TANK SUPP WLD, 2100 98
39	1	910008	1/2UNC HEX NUT
40	2	920504	1/2 LOCK WASHER
41	1	914008	1/2UNC HEX STOVER NUT
42	2	701215	1/4PIPE PLUG,.187 ORIFICE,POLY
43	1	501450	BLK PIPE ST EL 90DEG .25NPT
44	2	500079	3/4NPT-90 EL, POLY

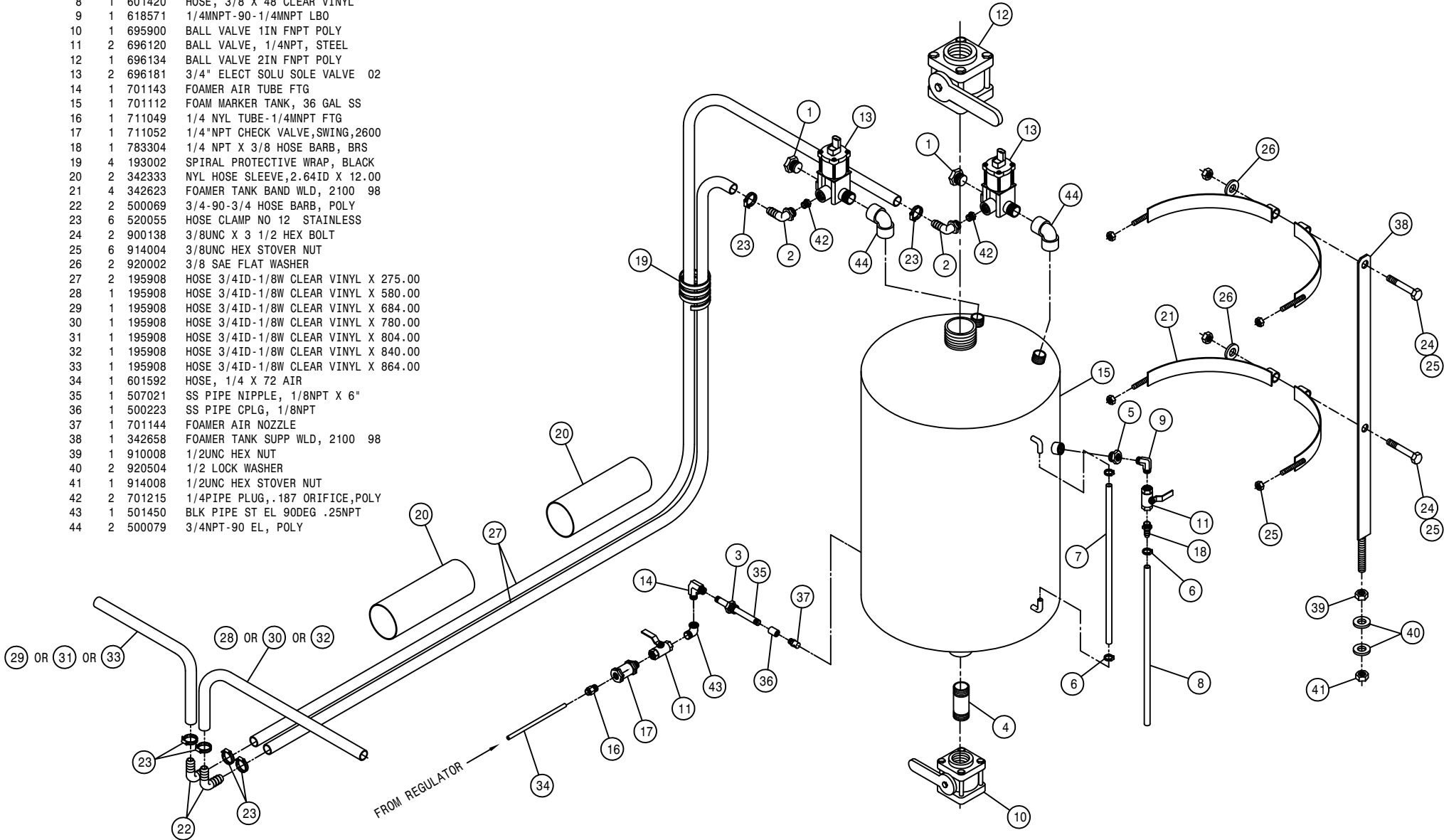

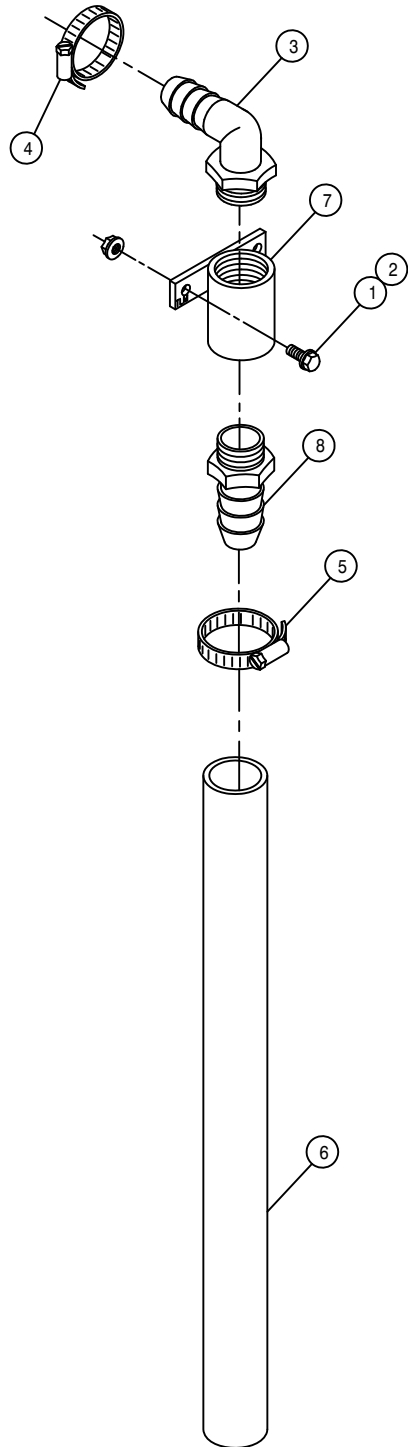

FOAMER DROP END ASSEMBLY

DET. QTY PART NO. DESCRIPTION

1	4	470118	1/4UNC X 3/4 FLANGE HEX BOLT
2	4	470121	1/4UNC HEX FLANGE LOCK NUT
3	2	500067	1 NPT-90-3/4 HOSE BARB, POLY
4	2	520055	HOSE CLAMP NO 12 STAINLESS
5	2	520085	HOSE CLAMP NO 24 STAINLESS
6	2	601367	HOSE, 1 1/4 X 24 2BR BLK EPDM
7	2	701102	FOAM MARKER DROP CPLR WELD
8	2	714561	1.00NPT-1.25 HOSE BARB

NOTE: QUANTITY LISTED IS FOR ONE MACHINE.

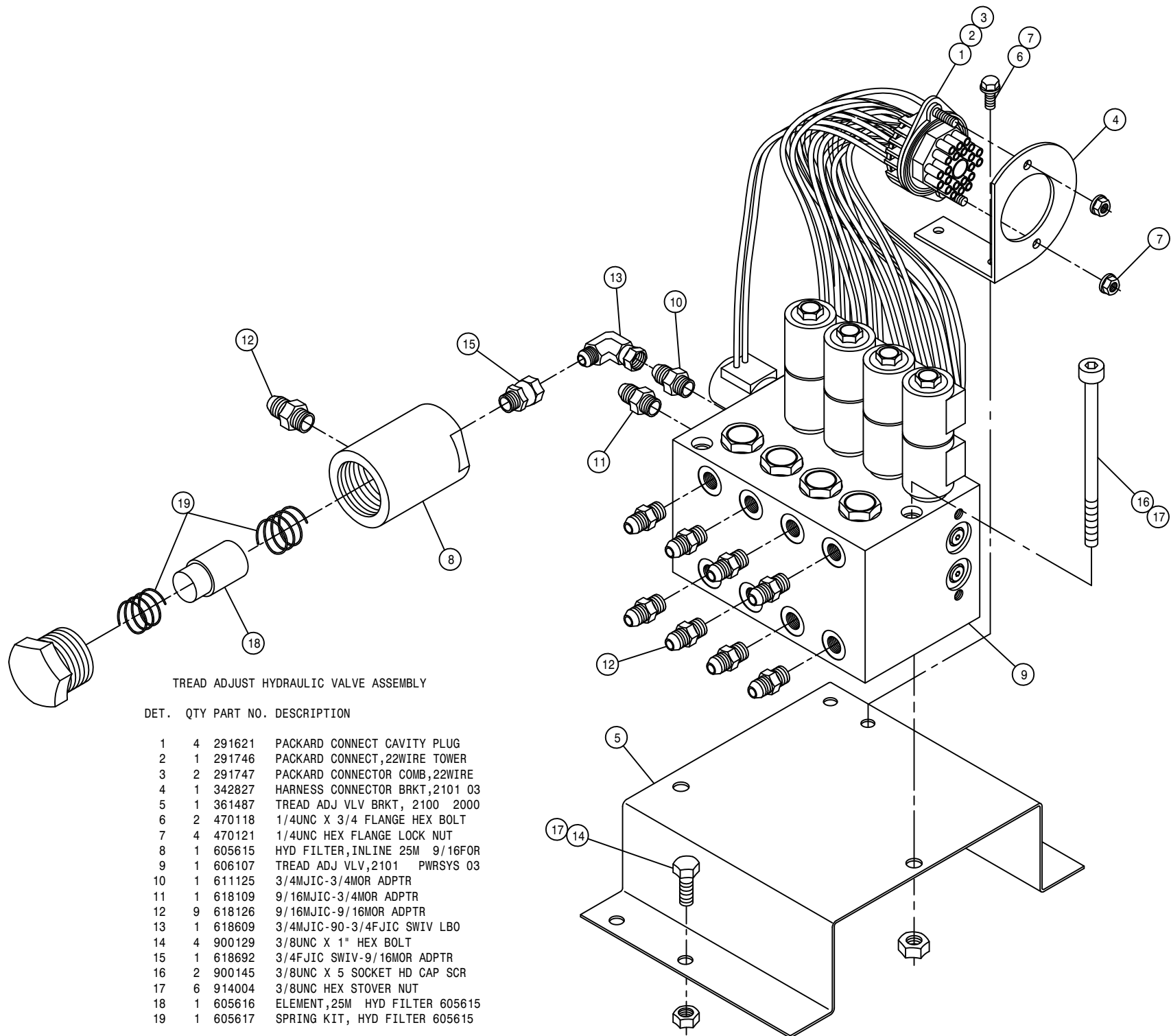

TREAD ADJUST HYDRAULIC VALVE ASSEMBLY

DET. QTY PART NO. DESCRIPTION

1	4	291621	PACKARD CONNECT CAVITY PLUG
2	1	291746	PACKARD CONNECT,22WIRE TOWER
3	2	291747	PACKARD CONNECTOR COMB,22WIRE
4	1	342827	HARNESS CONNECTOR BRKT,2101 03
5	1	361487	TREAD ADJ VLV BRKT, 2100 2000
6	2	470118	1/4UNC X 3/4 FLANGE HEX BOLT
7	4	470121	1/4UNC HEX FLANGE LOCK NUT
8	1	605615	HYD FILTER,INLINE 25M 9/16FOR
9	1	606107	TREAD ADJ VLV,2101 PWRSYS 03
10	1	611125	3/4MJIC-3/4MOR ADPTR
11	1	618109	9/16MJIC-3/4MOR ADPTR
12	9	618126	9/16MJIC-9/16MOR ADPTR
13	1	618609	3/4MJIC-90-3/4FJIC SWIV LBO
14	4	900129	3/8UNC X 1" HEX BOLT
15	1	618692	3/4FJIC SWIV-9/16MOR ADPTR
16	2	900145	3/8UNC X 5 SOCKET HD CAP SCR
17	6	914004	3/8UNC HEX STOVER NUT
18	1	605616	ELEMENT,25M HYD FILTER 605615
19	1	605617	SPRING KIT, HYD FILTER 605615

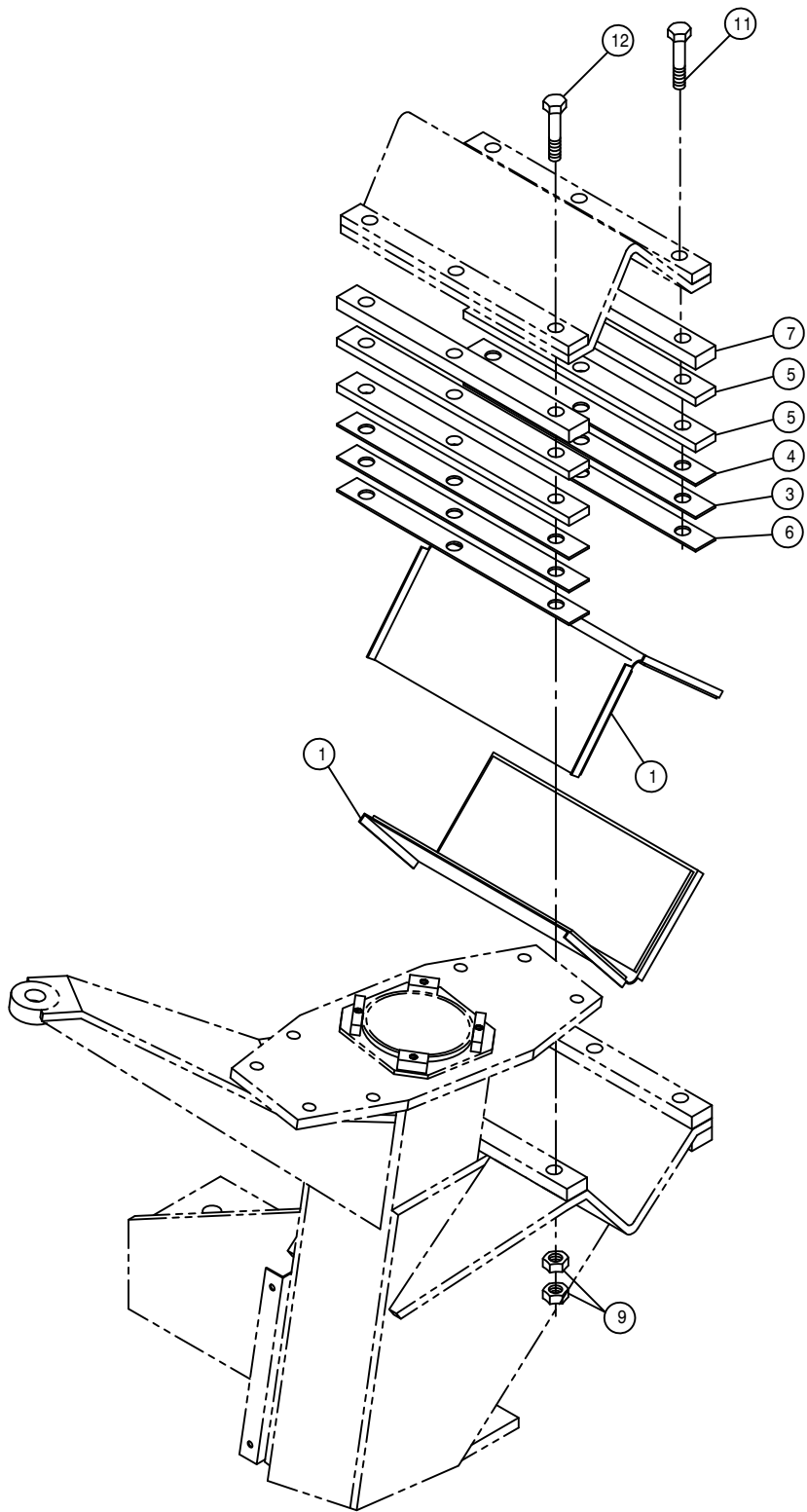

TREAD ADJUSTMENT ASSEMBLY

DET. QTY PART NO. DESCRIPTION

1	8	359294	TREAD ADJ XMBR BEARING ASSY 05	
2	4	358939	TREAD ADJ CYL EXT, 144" 2100 98	
3	16	358767	.025 LEG MT SHIM, 284T	94
4	4	358752	.074 LEG MT SHIM, 284T	94
5	16	358769	.250 LEG MT SHIM, 284T	94
6	8	358768	.037 LEG MT SHIM, 284T	94
7	8	358766	.375 LEG MT SPACER, 284T	94
8	4	900268	1/2UNC X 2 1/2 HEX BOLT	
9	48	914811	5/8UNF HEX NUT GR8	
10	4	900267	1/2UNC X 2" HEX BOLT	
11	12	900853	5/8UNF X 4 1/2 HEX BOLT GR8	
12	12	900838	5/8UNF X 4" HEX BOLT GR8	
13	8	914008	1/2UNC HEX STOVER NUT	

NOTE: QUANTITY LISTED IS FOR ONE MACHINE.

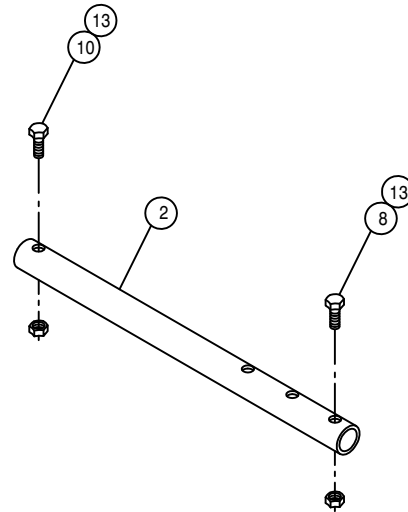

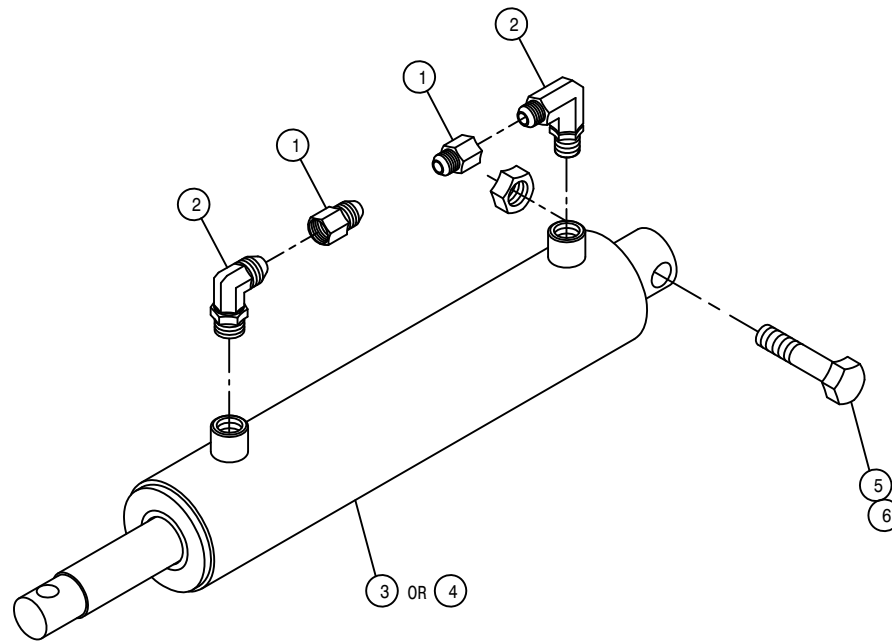

144" TREAD ADJUSTMENT LEG CYLINDER ASSEMBLY

DET. QTY PART NO. DESCRIPTION

1	1	618731	9/16JIC .025 ORIFICE ADPTR
2	2	618119	9/16MJC-90-9/16MOR LBO
3	1	621536	LEG CYL,TRD ADJ,LH 284-RH 2100
4	1	621534	LEG CYL,TRD ADJ,RH 284-LH 2100
5	1	900268	1/2UNC X 2 1/2 HEX BOLT
6	1	914008	1/2UNC HEX STOVER NUT
NS	1	621535	REPAIR KIT, HYD CYL 621534
NS	1	621537	REPAIR KIT, HYD CYL 621536

NOTE: 1. 621217 - RH LEG 144" TREAD ADJ CYLINDER ASSEMBLY WITH FITTINGS
 2. 621216 - LH LEG 144" TREAD ADJ CYLINDER ASSEMBLY WITH FITTINGS

PRESSURE WASHER OPTION

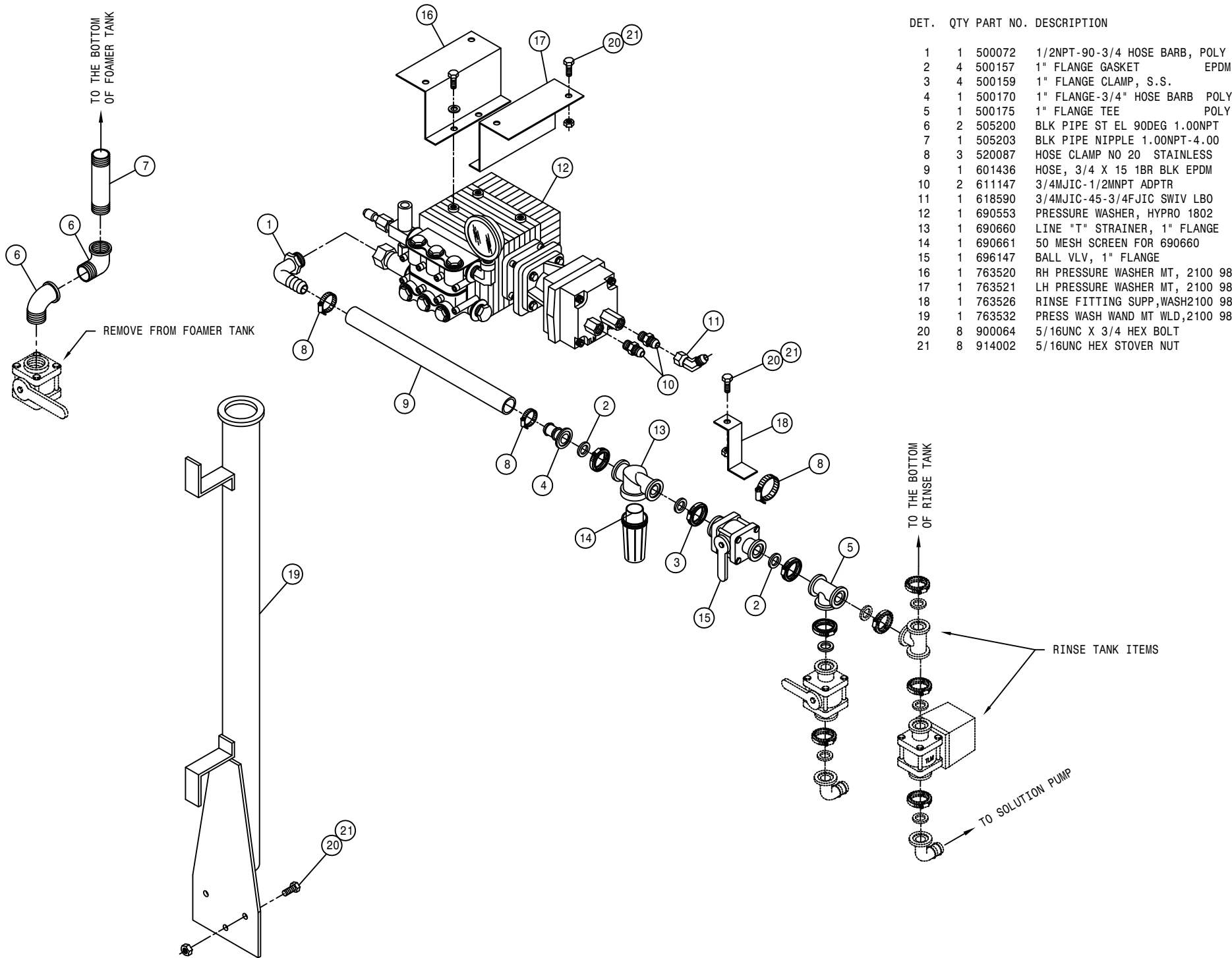

DET. QTY PART NO. DESCRIPTION

DET.	QTY	PART NO.	DESCRIPTION
1	1	500072	1/2NPT-90-3/4 HOSE BARB, POLY
2	4	500157	1" FLANGE GASKET EPDM
3	4	500159	1" FLANGE CLAMP, S.S.
4	1	500170	1" FLANGE-3/4" HOSE BARB, POLY
5	1	500175	1" FLANGE TEE, POLY
6	2	505200	BLK PIPE ST EL 90DEG 1.00NPT
7	1	505203	BLK PIPE NIPPLE 1.00NPT-4.00
8	3	520087	HOSE CLAMP NO 20 STAINLESS
9	1	601436	HOSE, 3/4 X 15 1BR BLK EPDM
10	2	611147	3/4MJIC-1/2MNPT ADPTR
11	1	618590	3/4MJIC-45-3/4FJIC SWIV LBO
12	1	690553	PRESSURE WASHER, HYPRO 1802
13	1	690660	LINE "T" STRAINER, 1" FLANGE
14	1	690661	50 MESH SCREEN FOR 690660
15	1	696147	BALL VLV, 1" FLANGE
16	1	763520	RH PRESSURE WASHER MT, 2100 98
17	1	763521	LH PRESSURE WASHER MT, 2100 98
18	1	763526	RINSE FITTING SUPP, WASH2100 98
19	1	763532	PRESS WASH WAND MT WLD, 2100 98
20	8	900064	5/16UNC X 3/4 HEX BOLT
21	8	914002	5/16UNC HEX STOVER NUT

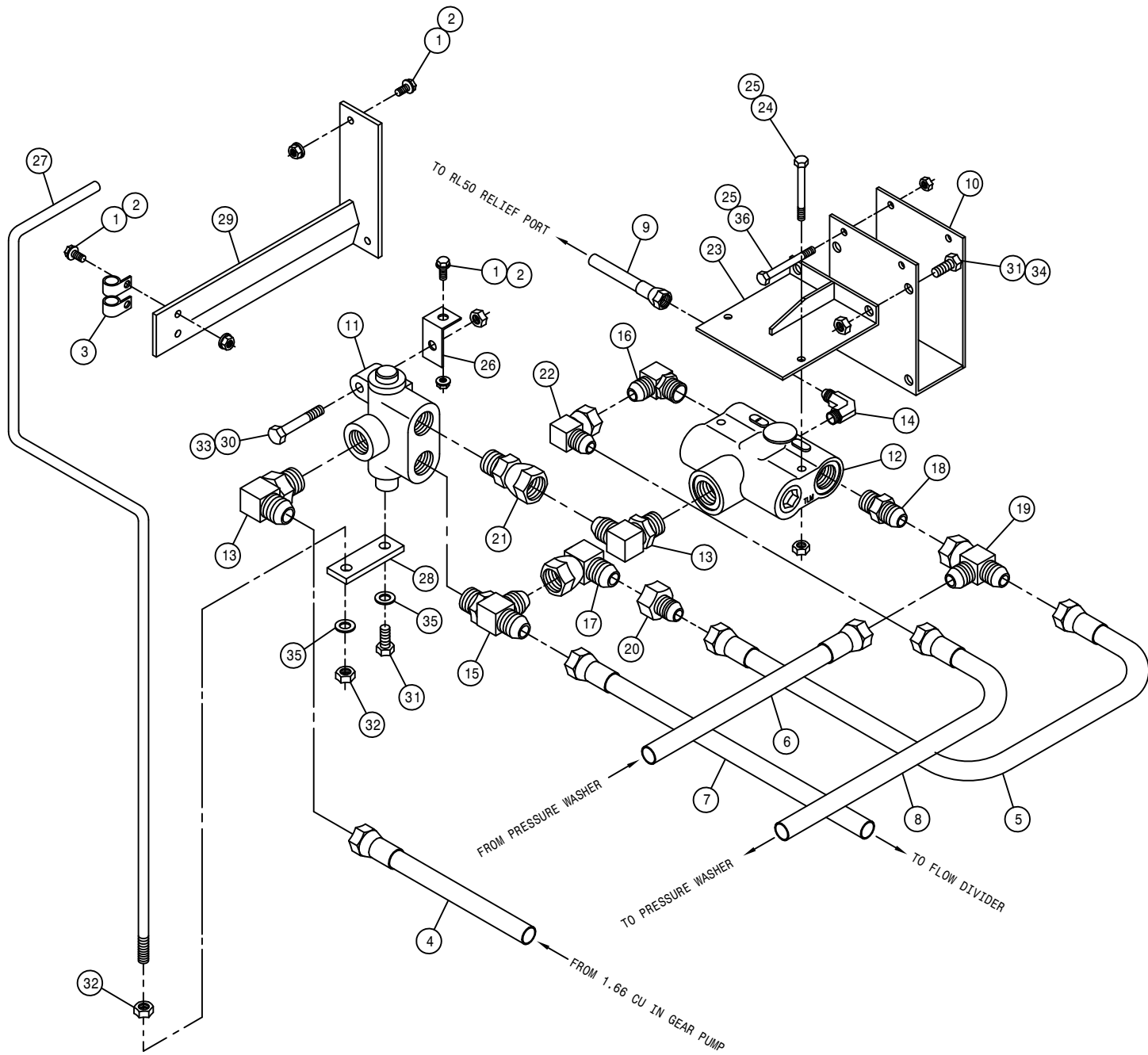

PRESSURE WASHER FLOW DIVIDER ASSEMBLY

DET.	QTY	PART NO.	DESCRIPTION
1	5	470118	1/4UNC X 3/4 FLANGE HEX BOLT
2	5	470121	1/4UNC HEX FLANGE LOCK NUT
3	2	520118	CUSH HOSE CLAMP 1/2D X 1/2W
4	1	614744	10C2AT-10FJX-10FJX-18 H/A
5	1	615385	08C1T-08FJX-08FJX-29 H/A
6	1	615465	08C1T-08FJX-08FJX-33 H/A
7	1	615741	10C1T-10FJX-10FJX-38 H/A
8	1	615742	08C1T-08FJX-08FJX-36 H/A
9	1	616043	04C1T-06FJX-06FJX-23 H/A
10	1	342311	TRACT VLV MT WLD,284 COMBO 96
11	1	690625	SELECT VLV,PRESS WASH 2100 98
12	1	607518	FLO DIV BGR56 6GPM PRI 7/8FOR
13	2	611128	7/8MJIC-90-7/8MOR LBO
14	1	618015	9/16MJIC-90-3/8MNPT LBO
15	1	618130	7/8MOR RUN TEE-7/8MJIC
16	1	618183	3/4MJIC-90-7/8MOR LBO
17	1	618301	7/8MJIC-90-7/8FJIC SWIV LBO
18	1	618327	3/4MJIC-7/8MOR ADPTR
19	1	618451	3/4FJIC SW RUN TEE-3/4MJIC
20	1	618523	7/8FJIC-3/4MJIC ADPTR
21	1	618594	7/8FJIC SWIV-7/8MOR ADPTR
22	1	618609	3/4MJIC-90-3/4FJIC SWIV LBO
23	1	763522	FLO DIV MT WLD, WASHER 2100 98
24	2	900007	1/4UNC X 2" HEX BOLT
25	4	914000	1/4UNC HEX STOVER NUT
26	1	763525	SEL VLV MT,PRESS WASH 2100 98
27	1	763527	SEL VLV HANDLE, WASHER 2100 98
28	1	763528	VLV HANDLE BRKT,WASHER 2100 98
29	1	763529	VLV HANDLE SUPP WLD,WASH210098
30	1	900067	5/16UNC X 1 1/2 HEX BOLT
31	3	900128	3/8UNC X 3/4 HEX BOLT
32	2	910004	3/8UNC HEX NUT
33	1	914002	5/16UNC HEX STOVER NUT
34	2	914004	3/8UNC HEX STOVER NUT
35	2	920502	3/8 LOCK WASHER
36	2	900010	1/4UNC X 3" HEX BOLT

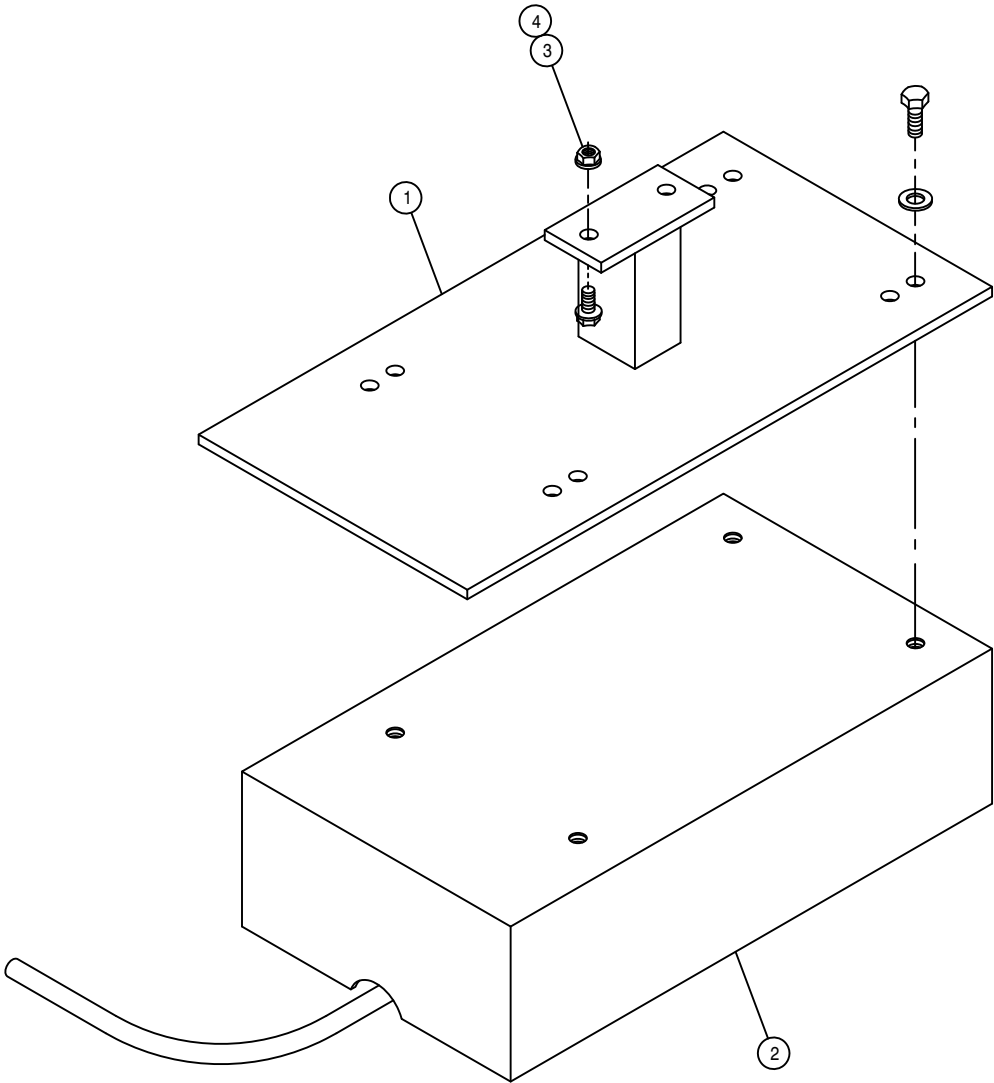

RADAR OPTION

DET.	QTY	PART NO.	DESCRIPTION
1	1	690462	RADAR MTG BRKT WLD, INJ SYS
2	1	690599	RAVEN RADAR UNIT W/CABLE
3	2	470118	1/4UNC X 3/4 FLANGE HEX BOLT
4	2	470121	1/4UNC HEX FLANGE LOCK NUT

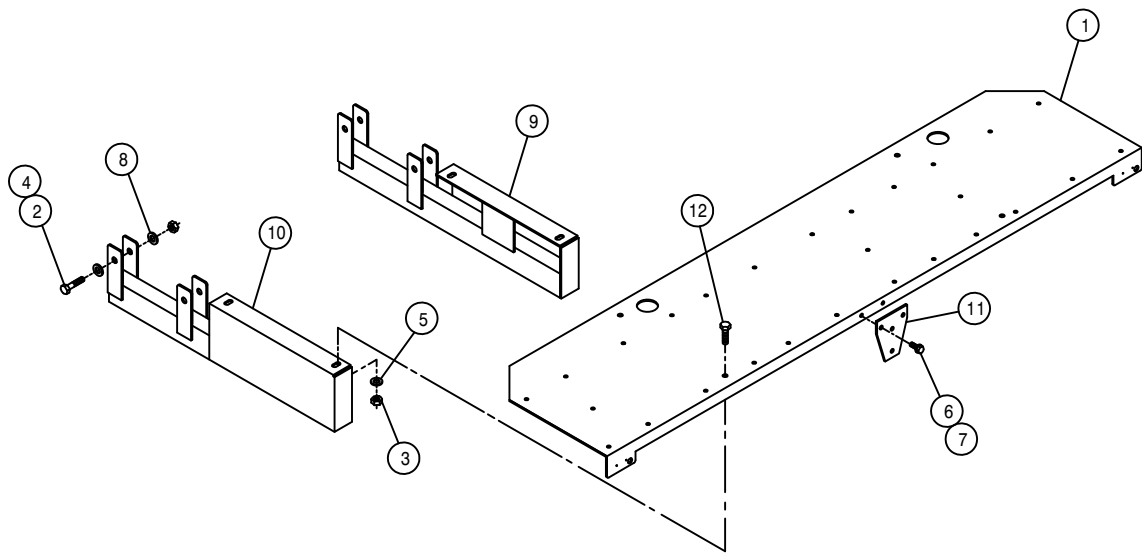

INJECTION SYSTEM PLATFORM OPTION

DET.	QTY	PART NO.	DESCRIPTION
	1	690637	INJ SYS PLATFORM WLD, 2100 99
	4	900340	5/8UNC X 3 1/2 HEX BOLT
	10	914008	1/2UNC HEX STOVER NUT
	4	914010	5/8UNC HEX STOVER NUT
	4	920004	1/2 SAE FLAT WASHER
	2	470118	1/4UNC X 3/4 FLANGE HEX BOLT
	2	470121	1/4UNC HEX FLANGE LOCK NUT
	8	483037	5/8 REGULAR FLAT WASHER
	1	690921	RH INJ PLATFORM MT WLD, 2101 04
	1	690922	LH INJ PLATFORM MT WLD, 2101 04
	1	690928	SMV BRKT, INJ PLATFORM, 2101 04
	4	900264	1/2UNC X 1 1/4 HEX BOLT

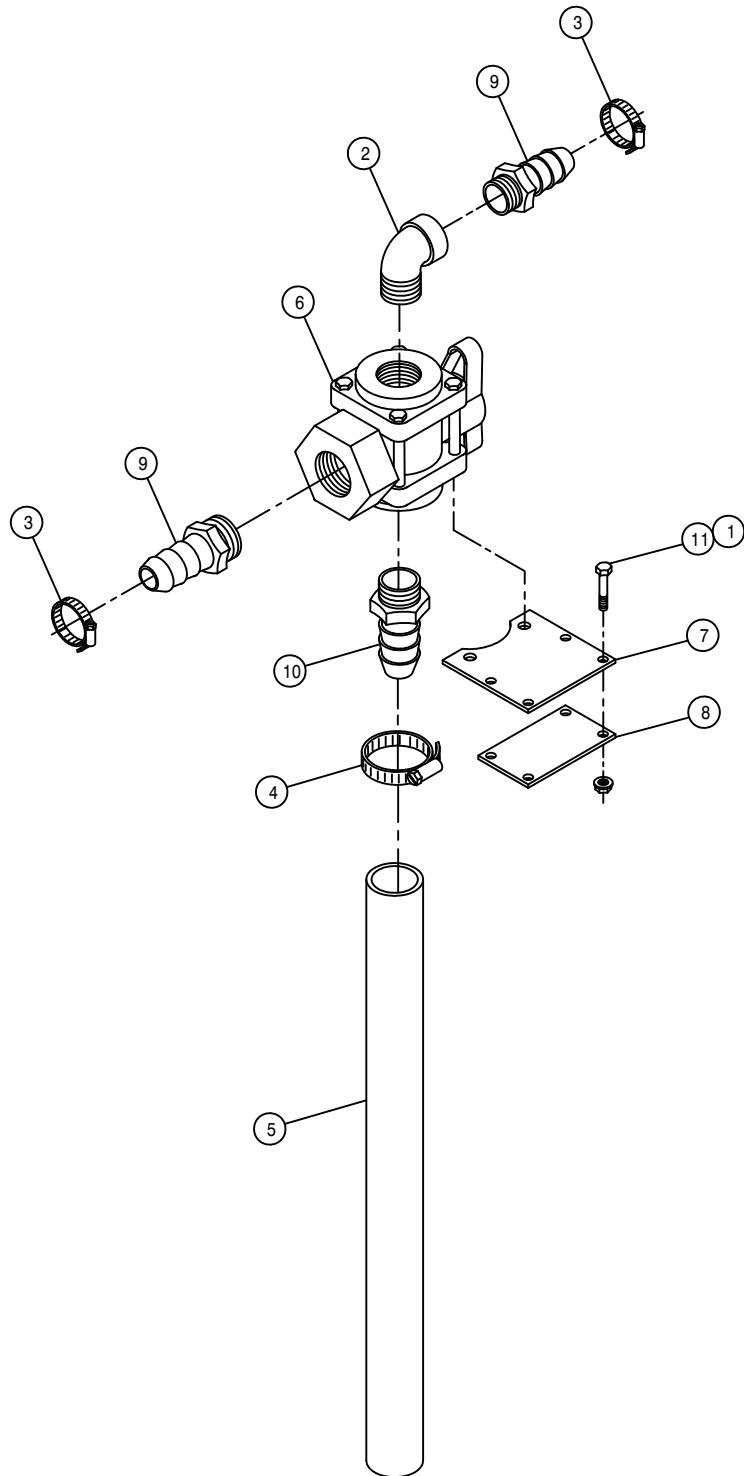

60''-80' FOAMER DIVERTER VALVE OPTION

DET. QTY PART NO. DESCRIPTION

1	8	470121	1/4UNC HEX FLANGE LOCK NUT
2	2	500014	1"NPT-90 ST EL, POLY
3	4	520055	HOSE CLAMP NO 12 STAINLESS
4	2	520085	HOSE CLAMP NO 24 STAINLESS
5	2	601367	HOSE, 1 1/4 X 24 2BR BLK EPDM
6	2	696133	BALL VLV,1.00NP 3WAY-BOTT POLY
7	2	701152	FOAMER DIVERTER VALVE MT BRKT
8	2	701153	FOAMER DIVERTER VLV BRKT KEEP
9	4	714331	1 NPT X 3/4 HOSE BARB
10	2	714561	1.00NPT-1.25 HOSE BARB
11	8	900007	1/4UNC X 2" HEX BOLT

NOTE: QUANTITY LISTED IS FOR ONE MACHINE.

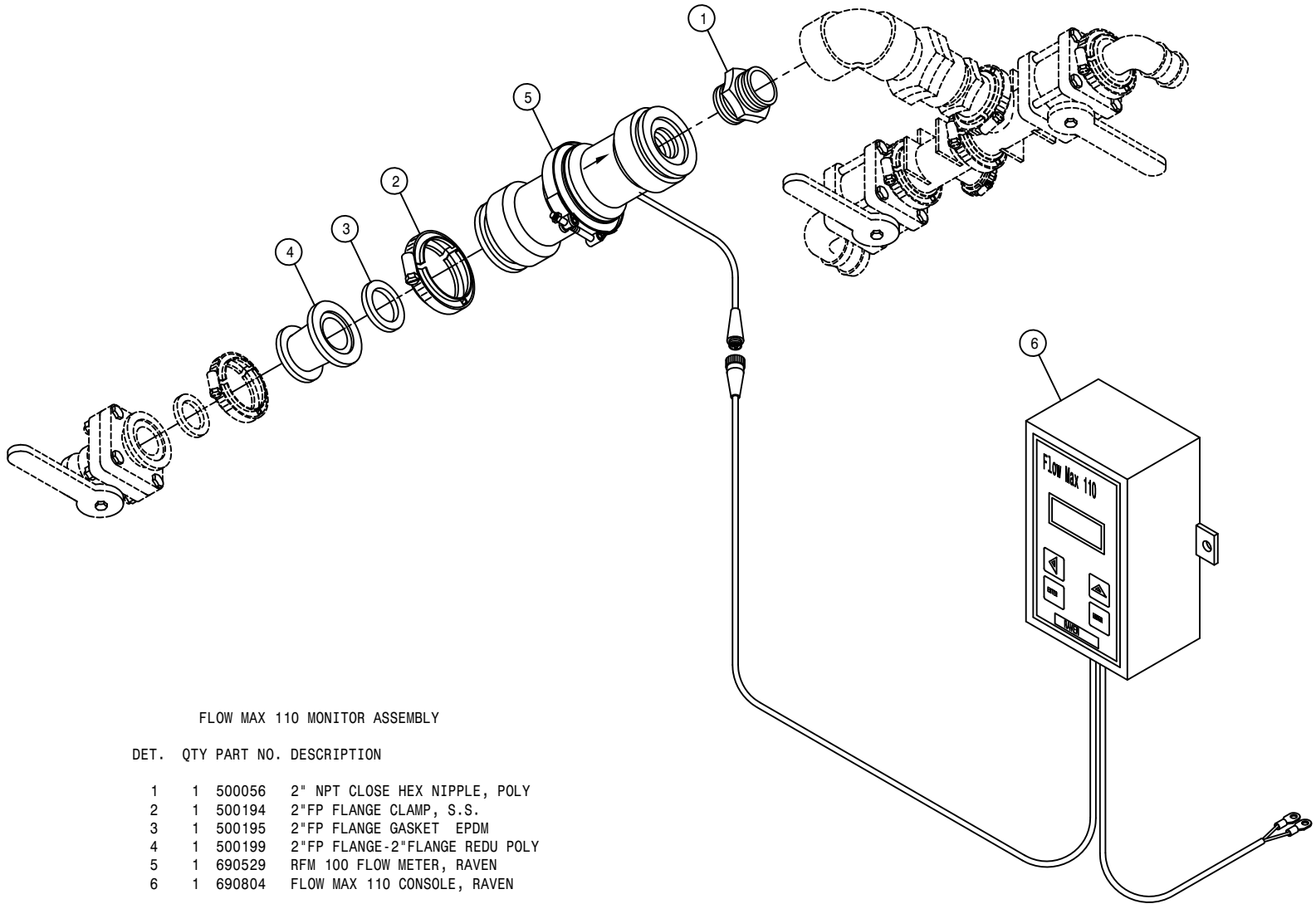

FLOW MAX 110 MONITOR ASSEMBLY

DET.	QTY	PART NO.	DESCRIPTION
	1	500056	2" NPT CLOSE HEX NIPPLE, POLY
	1	500194	2"FP FLANGE CLAMP, S.S.
	1	500195	2"FP FLANGE GASKET EPDM
	1	500199	2"FP FLANGE-2"FLANGE REDU POLY
	1	690529	RFM 100 FLOW METER, RAVEN
	1	690804	FLOW MAX 110 CONSOLE, RAVEN

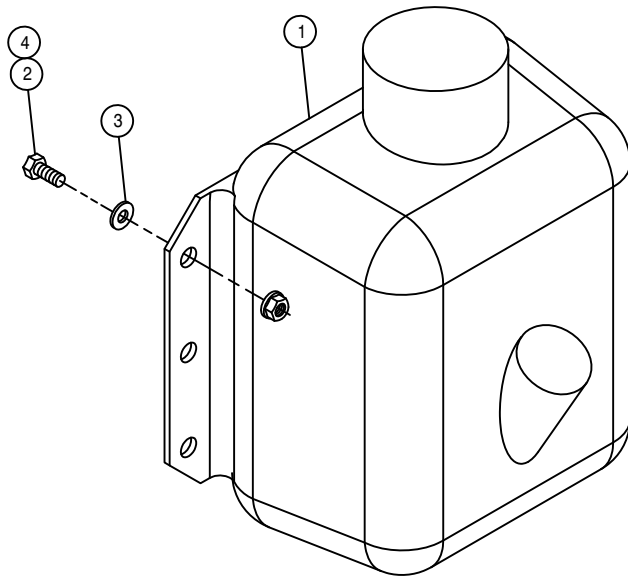

WINDSHIELD WASHER ASSEMBLY

DET. QTY PART NO. DESCRIPTION

1	1	470440	WINDSHIELD WASHER TANK ASSY 05
2	4	900002	1/4UNC X 3/4 HEX BOLT
3	4	470212	1/4 BONDED SEALING WASH, SS
4	4	470121	1/4UNC SER FLG LOCK NUT

NOTICE

The following page contains decals for the DTS 10.

These decals can be obtained from Hagie Mfg. Co. and should be used whenever your machine is repainted or when the decals become worn, weathered, or faded.

Special attention should be paid to decals involving personal safety. They have been attached for your protection.

KEEP THEM IN PLACE.

**Contact: Hagie Manufacturing Co.
Box 273
Clarion, Iowa 50525**

DTS 10 DECALS

QTY.	PART NO.	DESCRIPTION	LOCATION
1	650108	MAIN SPRAY POWER DECAL	ON SWITCH PANEL HOUSING
1	650109	LOW HYDRAULIC OIL DECAL	ON SWITCH PANEL HOUSING
1	650154	PATENTS,HAGIE UPFRONT DECAL	ON LOWER LEFT REAR OF MAINFRAME
1	650320	EMERGENCY EXIT DECAL	ON THE LOWER LEFT ON REAR WINDOW
1	650336	FOLD BOOM WARNING DECAL	ON RH SIDE WINDOW
1	650337	ELECTROCUTION HAZARD DECAL	ON RH SIDE WINDOW
1	650339	HYDRAULIC OIL INJ. DECAL	ON STEERING POST
1	650340	PARK BRAKE DECAL	NEAR PARK SWITCH
1	650343	HYDROSTATIC CONTROL DECAL	ON CONSOLE
1	650345	BOOM CONTROL PANEL DECAL	ON SWITCH PANEL COVER
1	650347	NOTICE-R134A CHARGE DECAL	ON ENGINE NEAR A/C COMPRESSOR
1	650348	NOTICE-DRAIN AIR TANK DECAL	ON AIR TANK
1	650349	LIGHT SWITCH PANEL DECAL	ON SWITCH PANEL IN HEADLINER
1	650350	CAUTION, BOOSTER TERMINAL DECAL	ON LOWER BACK SHEET METAL
1	650351	AGITATION VFC DECAL	ON LOWER BACK SHEET METAL
2	650352	RH TREAD ADJ INDICATOR DECAL	1-ON RH FRONT INDICATOR MOUNT 1-ON LH REAR INDICATOR MOUNT
2	650353	LH TREAD ADJ INDICATOR DECAL	1-ON LH FRONT INDICATOR MOUNT 1-ON RH REAR INDICATOR MOUNT
1	650367	AIR FILTER INSTRUCTION DECAL	ON ENGINE AIR FILTER END CAP
1	650369	FUSE BOX DECAL	ON FUSE BOX COVER
1	650370	SWITCH PANEL DECAL	ON SWITCH PANEL COVER
1	650371	TREAD ADJUST DECAL	ON CONSOLE
1	650372	MAIN ELECTRIC DISCONNECT DECAL	NEAR DISCONNECT SWITCH
1	650822	SOLUTION PUMP DECAL	ON FRONT MAINFRAME SHIELD
1	650831	EMERGENCY STOP DECAL	ON STEERING POST
1	650847	NO PASSENGER DECAL	ON LH REAR ON CAB
2	650848	SLIP OR FALL DECAL	ON BACK OF FUEL TANKS
2	650849	ENGINE FUEL DECAL	NEAR EACH FUEL TANK NECK
2	650850	CHEMICAL DECAL	ON TANK BAND TIE
2	650851	SHIELDS DECAL	ON LOWER REAR OF MAINFRAME
1	650852	READ MANUAL DECAL	ON LEFT CONSOLE TOP
1	650954	DIESEL DECAL	NEAR EACH FUEL NECK
1	650981	COOLING SYSTEM DECAL	NEAR RADIATOR CAP
1	650982	ELECTRICAL DECAL	ON ENGINE HOOD ABOVE BATTERY
4	650985	WHEEL BOLT TORQUE DECAL	ON EACH WHEEL RIM
1	KDC400	DTS 10 DECAL KIT	ON ENGINE HOOD, SOLUTION TANK

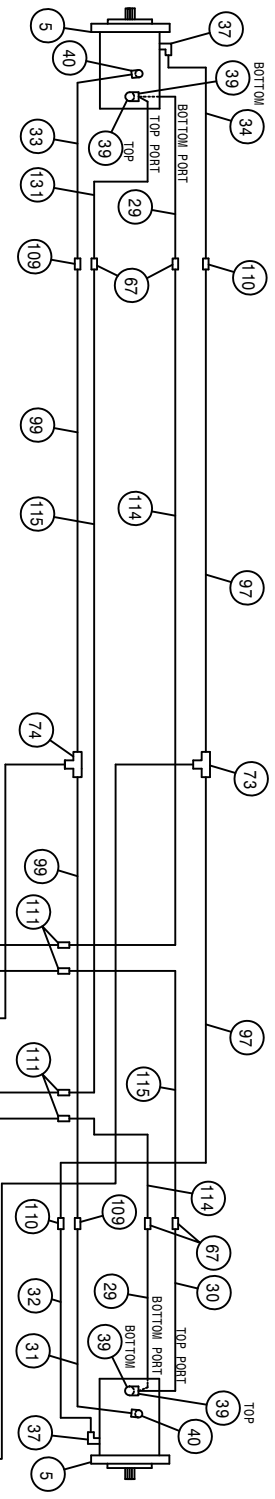

*NOTE:
 REFER TO DETAIL 57 TO CHECK AUX. SYSTEM - 1850 PSI
 REFER TO DETAIL 50 TO CHECK LIMIT SETTING - 4500 PSI
 REFER TO DETAIL 60 TO CHECK CHARGE PRESSURE - 380 PSI

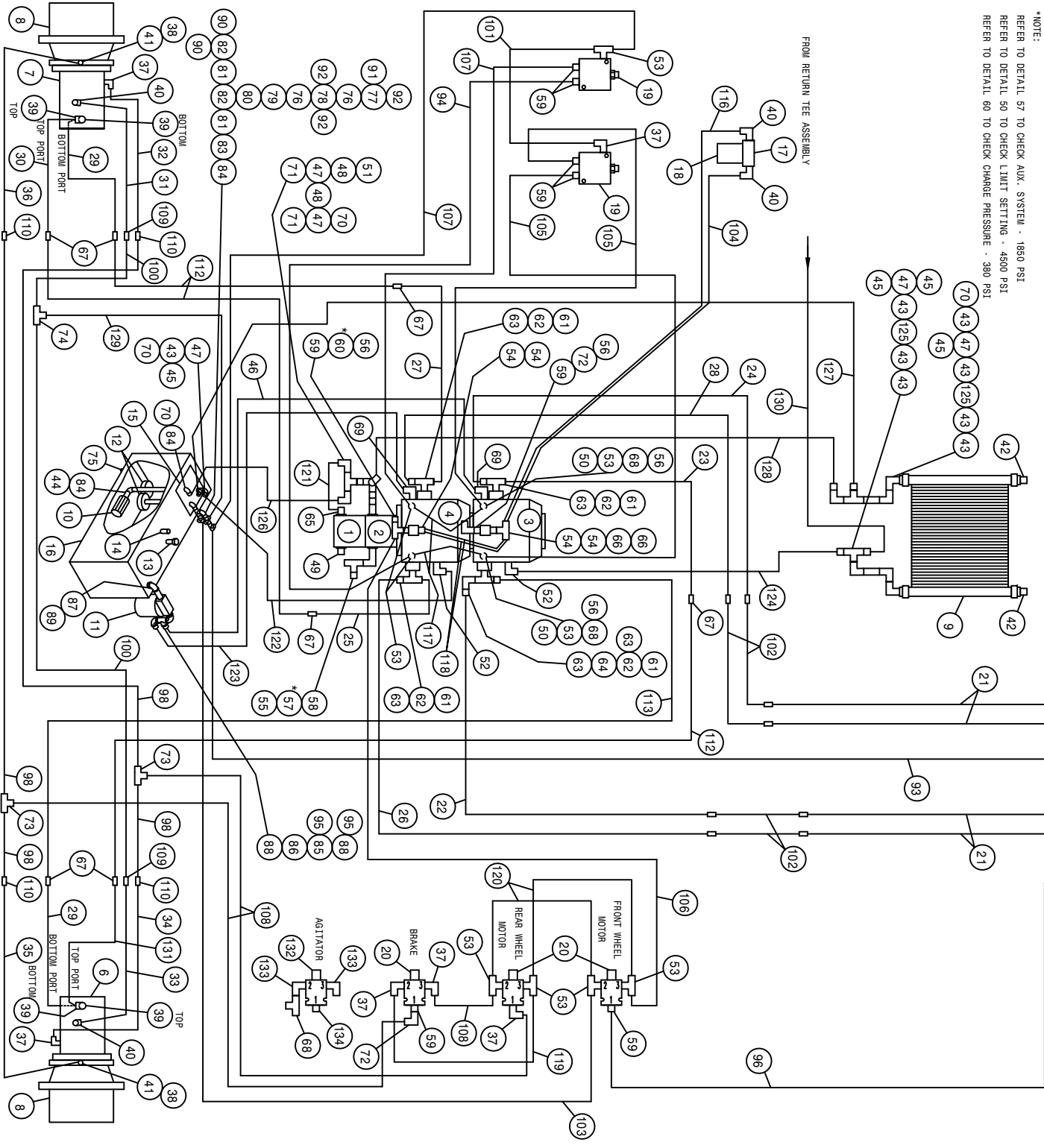

DTS 10 HYDRAULIC SCHEMATIC 2005
REFERENCE DRAWING NO. 498847S1

DET.	QTY	PART NO.	DESCRIPTION	DET.	QTY	PART NO.	DESCRIPTION
1	1	606929	SUND GEAR PUMP .66CT, SPLINED	68	3	618486	9/16FJIC SW RUN TEE-9/16MJIC
2	1	606932	SUND GEAR PUMP,1.60CI,SPLINED	69	2	618564	1IN HOSE BARB-90-1 5/16MOR
3	1	606231	SUND 75CC PUMP,C/C MT (.022)	70	4	714560	INPT X 1 HOSE BARB
4	2	606234	SUND 75CC PUMP, C/B MT (.022)	71	2	716000	3/4 HOSE BARB-90-1MNPT
5	2	610637	SUND HYD MOTOR, M46-4019	72	2	618618	9/16MJIC-90-9/16FJIC SWIV LBO
6	1	608000	SAUER HYD MOTOR, M46-4024	73	3	618019	9/16MJIC UNION TEE
7	1	608003	SAUER HYD MOTOR,M46-4194 W/SEN	74	2	618311	3/4MJIC UNION TEE
8	2	610803	TORQ HUB, 24.40:1 W/BRAKE	75	1	470308	1/2MNPT DRAIN PLUG,AL HD,MAG
9	1	618606	OIL COOLER, BLISSFIELD 65027	76	2	503600	CLOSE NIPPLE .50NPT
10	1	605600	TANK FILTER, 100 MESH,1"FNPT	77	1	503820	BLK PIPE TEE .50NPT
11	1	605601	PARKER FILTER ASSY,10M,1.25NPT	78	1	503824	BLK PIPE CROSS .50NPT
12	2	605603	LINE SUMP DIFUSER	79	1	504210	RED BUSH 3/4 NPT X 1/2 NPT
13	1	611052	FILLER BREATHER 3/4NPT	80	1	504610	BLK PIPE ST EL 90DEG .75NPT
14	1	614453	DIPSTICK, 8IN	81	2	504702	CLOSE NIPPLE .75NPT
15	1	760090	RECEIVER PLT WLD 8240	82	2	504955	BLK PIPE TEE .75NPT
16	1	760268	HYD TANK WLD, 2100	83	1	505213	RED BUSH 1 X 3/4 BLK MAL
17	1	605608	HYD FILTER HEAD, DONALDSON	84	3	505300	BLK PIPE EL 90DEG 1.00NPT
18	1	605609	HYD FILTER ELEMENT, DONALDSON	85	1	506105	BLK PIPE TEE 1.25NPT
19	2	610580	REMOTE FLUSHING VALVE, SUND	86	1	506200	CLOSE NIPPLE 1.25NPT
20	3	606138	HYD SOLE VLV,2P-3W,9/16FOR, WP	87	1	506303	BLK PIPE EL 90DEG 1.25NPT
21	4	615724	FRT MAIN HYD TUBE ASSY,2100 98	88	2	506410	BLK PIPE ST EL 90DEG 1.25NPT
22	1	615717	RH FRT PUMP LMR TUBEASSY210098	89	1	506604	BLK PIPE NIPPLE 1.25NPT-4.00
23	1	615718	LH FRT PUMP UPR TUBEASSY210098	90	2	610305	3/4MJIC-90-3/4MNPT LBO
24	1	615719	LH FRT PUMP LMR TUBEASSY210098	91	2	618018	9/16MJIC-1/2MNPT ADPTR
25	1	615720	RH REAR PUMP UPR TUBE ASSY	92	3	618107	9/16MJIC-90-1/2MNPT LBO
26	1	615721	RH REAR PUMP LMR TUBE ASSY	93	1	615737	08C2AT-08FJX-08FJX90-198
27	1	615722	LH REAR PUMP UPR TUBE ASSY	94	1	616254	04C2AT-06FJX-06FJX-26
28	1	615723	LH REAR PUMP LMR TUBE ASSY	95	2	715664	1 1/4 NPT X 1 HOSE BARB
29	4	615708	LMR HYD TUBE ASSY,LEG 2100 98	96	1	611246	04C1T-06FJX-06FJX-174
30	2	615709	UPR HYD TUBE ASSY,LEG 2100 98	97	2	614152	04C1T-06FJX-06FJX-114
31	2	615710	RF/LR HYD DRN TUBE ASSY2100 98	98	4	614157	04C1T-06FJX-06FJX-101
32	2	615712	RF/LR HYD CTRL TUBE ASSY210098	99	2	614546	08C1T-08FJX-08FJX-115
33	2	615809	LF/RR HYD DRN TUBE ASSY2100 03	100	2	614688	08C1T-08FJX-08FJX-108
34	2	615713	LF/RR HYD CTRL TUBE ASSY210098	101	4	614713	04C1T-06FJX-06FJX-24
35	1	615815	RH HYD BRAKE TUBE ASSY,2101 04	102	1	614734	12TWM-12MJ-12MJ-16
36	1	615814	LH HYD BRAKE TUBE ASSY,2101 04	103	1	616026	04C1T-06FJX-06FJX-57
37	8	618119	9/16MJIC-90-9/16MOR LBO	104	1	614383	08C1T-08FJX-08FJX-26
38	2	618634	9/16MJIC-45-9/16FJIC SWIV LBO	105	2	616255	04C2AT-06FJX-06FJX-29
39	8	618178	1 5/16MJIC-90-1 5/16MOR LBO	106	1	616039	04C1T-06FJX-06FJX-19
40	6	618474	3/4MJIC-90-1 1/16MOR LBO	107	3	616049	04C1T-06FJX-06FJX-23
41	2	618304	9/16MJIC-7/16MOR ADPTR	108	4	618314	04C1T-06FJX-06FJX-26
42	2	505102	PIPE PLUG 1.00NPT SQ HD	109	4	619010	3/4MJIC UNION
43	8	505200	BLK PIPE ST EL 90DEG 1.00NPT	110	6	619010	9/16MJIC UNION
44	1	505203	BLK PIPE NIPPLE 1.00NPT-4.00	111	4	618177	1 1/16MJIC UNION
45	4	714331	1 NPT X 3/4 HOSE BARB	112	3	614735	12TWM-16FJX-16FJX-75
46	1	601599	HOSE, 1 X 3/2 IFBR-1SPI	113	1	614735	12TWM-12FJX90-16FJX-75
47	5	505101	BLK PIPE TEE 1.00NPT	114	2	614737	12TWM-12FJX90-16FJX-99
48	2	505105	1MNPT HEX PIPE NIPPLE STL	115	2	614738	12TWM-12FJX90-16FJX-114
49	1	611126	7/8MJIC-7/8MOR ADPTR	116	1	615626	08C1T-08FJX-08FJX-15
50	2	618734	9/16JIC .047 ORIFICE ADPTR	117	2	616252	04C2AT-06FJX-06FJX-13
51	1	618090	1 5/16MOR-1FNPT ADPTR	118	2	614739	08C1T-08FJX-08FJX90-16
52	2	618118	3/4 HOSE BARB-90-1 1/16MOR	119	1	614712	04C1T-06FJX-06FJX-20
53	9	618629	9/16MOR BRANCH TEE-9/16MJIC	120	2	615725	04C1T-06FJX-06FJX-10
54	4	618327	3/4MJIC-7/8MOR ADPTR	121	1	601399	HOSE, 3/4 X 13 IFBR-1SPI
55	4	618328	7/8FJIC CAP NUT	122	1	601384	HOSE, 3/4 X 40 IFBR-1SPI
56	4	618531	9/16FJIC CAP NUT	123	1	601381	HOSE, 1 X 39 IFBR-1SPI
57	1	618333	7/8FJIC SW RUN TEE-7/8MJIC	124	1	601385	HOSE, 1 X 39 IFBR-1SPI
58	1	618335	7/8MJIC-90-1 1/16MOR LBO	125	2	505208	BLK PIPE NIPPLE 1.00NPT-2.50
59	8	618126	9/16MJIC-9/16MOR ADPTR	126	1	601594	HOSE, 1 X 56 IFBR-1SPI
60	1	618514	9/16FJ SW BRANCH TEE-9/16MJ	127	1	601387	HOSE, 1 X 104 IFBR-1SPI
61	4	618598	1" 4-BOLT FLG X 1 5/16 FOR	128	1	601401	HOSE, 3/4 X 88 IFBR-1SPI
62	4	618599	1 5/16MOR BRANCH TEE-1 5/16MJ	129	1	615465	08C1T-08FJX-08FJX-53
63	5	618541	1 5/16FJIC-1 1/16MJIC ADPTR	130	1	601598	HOSE, 3/4 X 33 IFBR-1SPI
64	1	618640	1 5/16MJ-90-1 5/16FJ SWIV LBO	131	2	615808	UPR HYD TUBE ASSY,LEG 2100 03
65	1	618075	3/4 HOSE BARB-1 1/16MOR	132	2	606139	HYD SOLE VLV,2P3W,3/4FOR, WP
66	2	618643	3/4FJ SW BRANCH TEE-3/4MJ	133	2	618115	9/16MJIC-90-3/4MOR LBO
67	11	618577	1 5/16MJIC UNION	134	1	618109	9/16MJIC-3/4MOR ADPTR

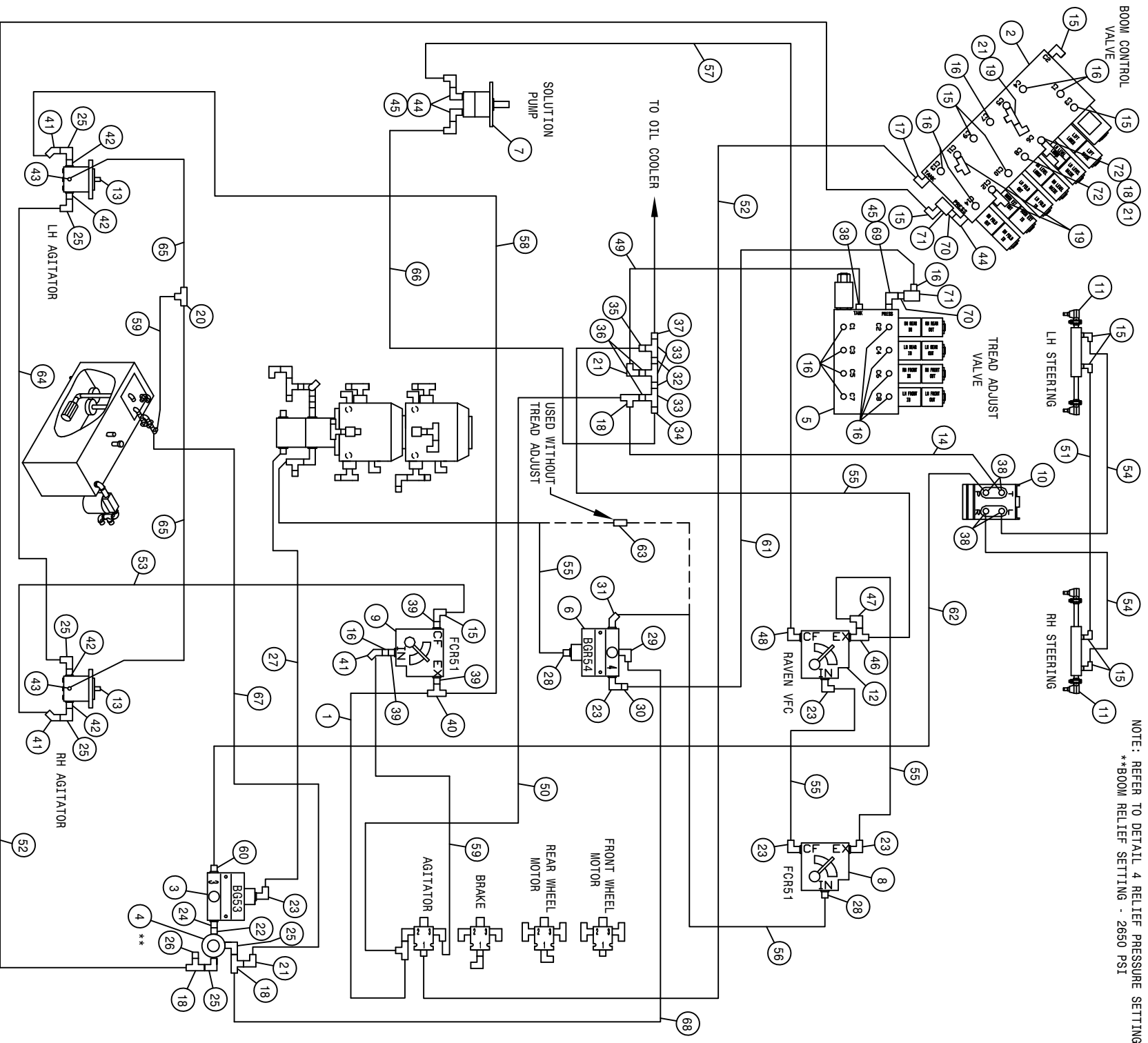

NOTE: REFER TO DETAIL 4 RELIEF PRESSURE SETTING.
 **BOOM RELIEF SETTING - 2650 PSI

DTS 10 HYDRAULIC SCHEMATIC 2005
REFERENCE DRAWING NO. 498847S2

DET.	QTY	PART NO.	DESCRIPTION	DET.	QTY	PART NO.	DESCRIPTION
1	1	615621	06C1T-06FJX-06FJX-24	H/A	37	713220	HOSE BARB 3/4 NPT X 3/4
2	1	606104	BOOM CTRL VLV, STS	PMSYS 03	38	618109	9/16MJIC-3/4MOR ADPTR
3	1	610307	FLO DIV BG53 3GPM PRI 7/8FOR		39	618172	7/8MOR-9/16FOR ADPTR
4	1	607512	RELIEF VALVE, RL50, 1850 PSI		40	618629	9/16MOR BRANCH TEE-9/16MJIC
5	1	606107	TREAD ADJ VLV, 2101	PMSYS 03	41	618634	9/16MJIC-45-9/16FJIC SWIV LBO
6	1	607528	FLO DIV BGR54, 4GPM PRI 7/8FOR		42	618092	1 1/16MOR-1/2FNPT ADPTR
7	1	690573	HYD MOTOR, FLOMAX HI-SPEED		43	618358	9/16MJIC-45-1/4MNPT LBO
8	1	606818	FLO CONT FCR51 0-16GPM 7/8FOR		44	618241	3/4MJIC-90-3/4MOR LBO
9	1	606827	FLO CONT FCS1 0-3 VARI 7/8FOR		45	618609	3/4MJIC-90-3/4FJIC SWIV LBO
10	1	749318	STRG MTR, 7.3CID, NON-LOAD 1031		46	618130	7/8MOR RUN TEE-7/8MJIC
11	2	621516	STRG CYL ASSY, 2100		47	618301	7/8MJIC-90-7/8FJIC SWIV LBO
12	1	690621	VALVE HYD CTRL, 16GPM RAVEN		48	618183	3/4MJIC-90-7/8MOR LBO
13	2	610510	CESSNA GEAR MOTOR 1.48CI		49	616037	04C1T-06FJX-06FJX-29
14	1	616049	04C1T-06FJX-06FJX-26	H/A	50	614693	06C1T-06FJX-06FJX-168
15	10	618119	9/16MJIC-90-9/16MOR LBO		51	611246	04C1T-06FJX-06FJX-174
16	15	618126	9/16MJIC-9/16MOR ADPTR		52	615735	06C1T-06FJX-06FJX-300
17	1	618115	9/16MJIC-90-3/4MOR LBO		53	614549	06C1T-06FJX-06FJX-140
18	4	618486	9/16FJIC SW RUN TEE-9/16MJIC		54	614639	04C1T-06FJX-06FJX-126
19	3	618444	9/16MOR RUN TEE-9/16MJIC		55	614732	10C2AT-10FJX-10FJX-29
20	1	618019	9/16MJIC UNION TEE		56	614555	10C2AT-10FJX-10FJX-42
21	4	618618	9/16MJIC-90-9/16FJIC SWIV LBO		57	616057	08C1T-08FJX-08FJX-88
22	1	500000	1/2MNPT HEX PIPE NIPPLE STL		58	615348	06C1T-06FJX-06FJX-127
23	5	611128	7/8MJIC-90-7/8MOR LBO		59	615401	06C1T-06FJX-06FJX-22
24	1	618072	7/8MOR-1/2FNPT ADPTR		60	618310	9/16MJIC-7/8MOR ADPTR
25	6	618107	9/16MJIC-90-1/2MNPT LBO		61	615728	04C1T-06FJX-06FJX-80
26	1	618531	9/16FJIC CAP NUT		62	615730	04C1T-06FJX-06FJX-150
27	1	614744	10C2AT-10FJX-10FJX-18	H/A	63	618456	7/8MJIC UNION
28	2	611126	7/8MJIC-7/8MOR ADPTR		64	615732	06C1T-06FJX-06FJX-194
29	1	618015	9/16MJIC-90-3/8MNPT LBO		65	615733	06C1T-06FJX-06FJX-101
30	1	618557	7/8FJIC-9/16MJIC ADPTR		66	615736	08C2AT-08FJX-08FJX-46
31	1	618644	7/8MJIC-45-7/8MOR LBO		67	615442	04C1T-06FJX-06FJX-55
32	2	504702	CLOSE NIPPLE .75NPT		68	616028	04C1T-06FJX-06FJX-47
33	3	504955	BLK PIPE TEE .75NPT		69	611125	3/4MJIC-3/4MOR ADPTR
34	1	610300	3/4MJIC-3/4MNPT ADPTR		70	618692	3/4FJIC SWIV-9/16MOR ADPTR
35	1	618059	7/8MJIC-3/4MNPT ADPTR		71	605615	HYD FILTER, INLINE 25M 9/16FOR
36	2	618642	9/16MJIC-3/4MNPT ADPTR		72	614763	9/16MJIC-9/16MOR, .042 CHK ADPT

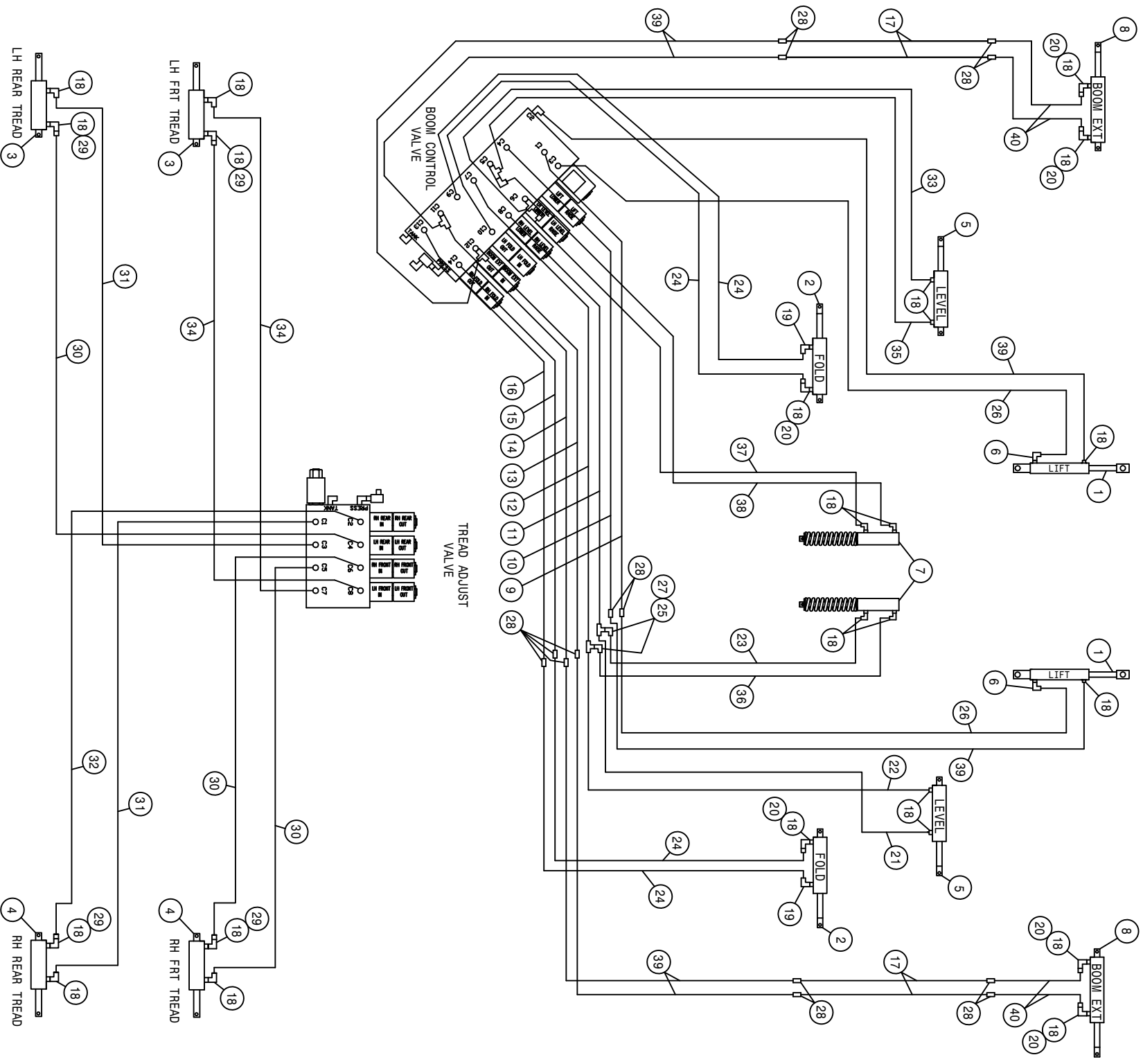

DTS 10 HYDRAULIC SCHEMATIC 2005
REFERENCE DRAWING NO. 498847S3

DET.	QTY	PART NO.	DESCRIPTION	DET.	QTY	PART NO.	DESCRIPTION
1	2	621518	TRANSOM LIFT CYL ASSY	21	1	616028	04C1T-06FJX-06FJX-47
2	2	621520	BOOM HINGE FOLD CYL ASSY	22	1	614714	04C1T-06FJX-06FJX-34
3	2	621534	LEG CYL, TRD ADJ, RH 284-LH 2100	23	1	616049	04C1T-06FJX-06FJX-26
4	2	621536	LEG CYL, TRD ADJ, LH 284-RH 2100	24	4	615442	04C1T-06FJX-06FJX-55
5	2	621522	BOOM LEVEL CYL ASSY	25	2	618618	9/16MJIC-90-9/16FJIC SWIV LBO
6	2	618689	9/16MOR-90-9/16MJ .042 CHK VLV	26	2	616174	04C1T-06FJX-06FJX-70
7	2	621524	ACCUMULATOR CYL ASSY	27	2	618019	9/16MJIC UNION TEE
8	2	621526	BOOM CNTR SECT CYL ASSY(12T)	28	14	619010	9/16MJIC UNION
9	1	615761	LIFT RAISE HYD TUBE ASSY	29	4	618731	9/16JIC .025 ORIFICE ADPTR
10	1	615762	LIFT LOWER HYD TUBE ASSY	30	3	611204	04C1T-06FJX-06FJX-78
11	1	615763	LEVEL RAISE HYD TUBE ASSY	31	2	614077	04C1T-06FJX-06FJX-88
12	1	615764	LEVEL LOWER HYD TUBE ASSY	32	1	615726	04C1T-06FJX-06FJX-73
13	1	615766	BOOM EXTN RAISE HYD TUBE ASSY	33	1	615314	04C1T-06FJX-06FJX-50
14	1	615767	BOOM EXTN LOWER HYD TUBE ASSY	34	2	615729	04C1T-06FJX-06FJX-84
15	1	615768	RH FOLD RAISE HYD TUBE ASSY	35	1	616026	04C1T-06FJX-06FJX-37
16	1	615769	RH FOLD LOWER HYD TUBE ASSY	36	1	614712	04C1T-06FJX-06FJX-20
17	4	615684	HYD TUBE ASSY, BOOM EXT FOLD96	37	1	614713	04C1T-06FJX-06FJX-24
18	24	618119	9/16MJIC-90-9/16MOR LBO	38	1	616037	04C1T-06FJX-06FJX-29
19	2	618688	9/16MOR-90-9/16MJ .025 CHK VLV	39	6	616040	04C1T-06FJX-06FJX-67
20	6	618733	9/16JIC .042 ORIFICE ADPTR	40	4	616043	04C1T-06FJX-06FJX-23

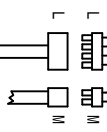
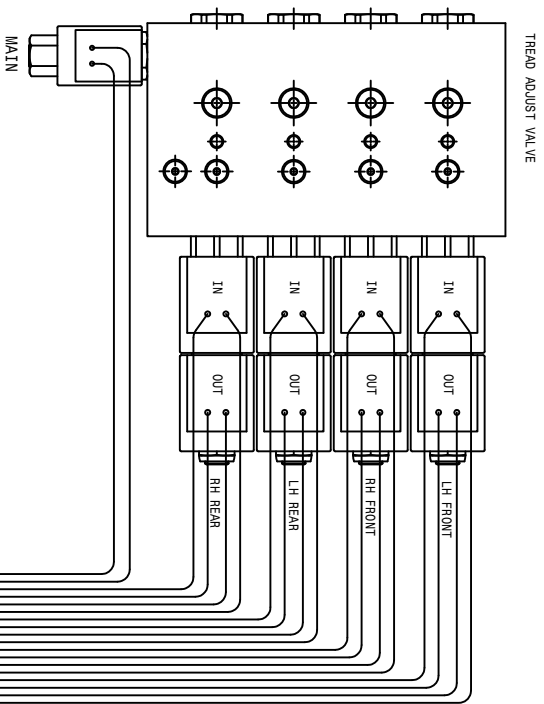
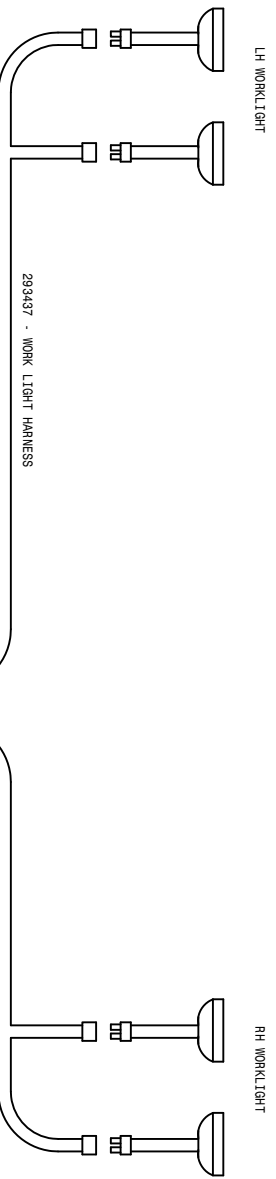

293748 - ENGINE WIRE
HARNESS 2101 03
SHEET 1 OF 5

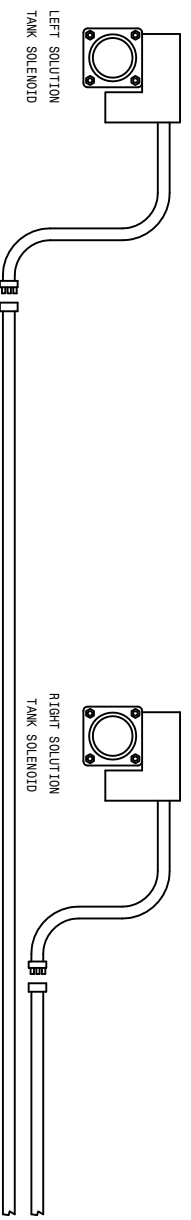
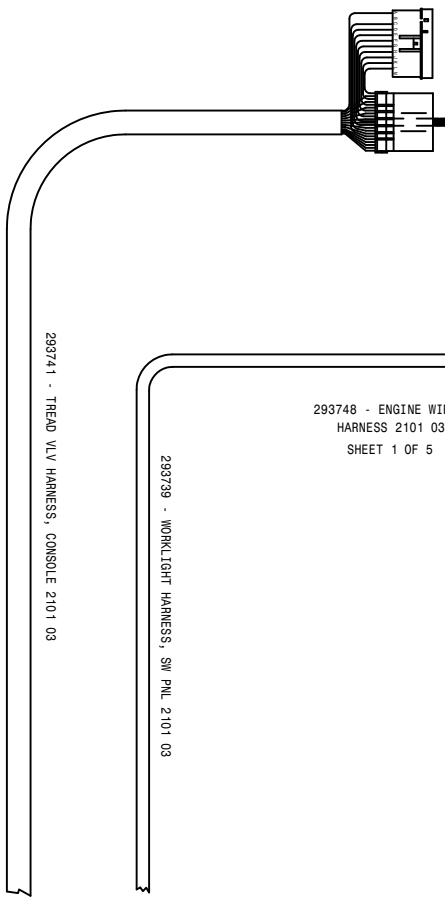

HYD TANK LIGHT

BROWN W/YELLOW

4

TO HARNESS 293829 SHEET 4 OF 5

GREEN

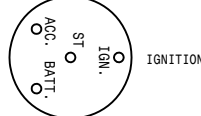
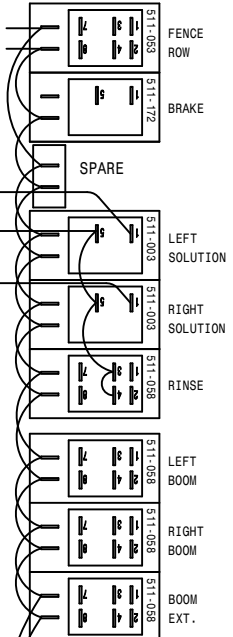

293742 - SWITCH LIGHT PWR WIRE ASSY

TO SOLUTION SWITCH SHEET 5 OF 5

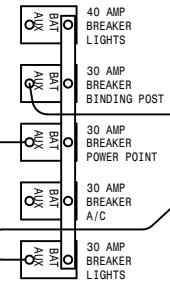

3

RED

BLACK

2

BLACK

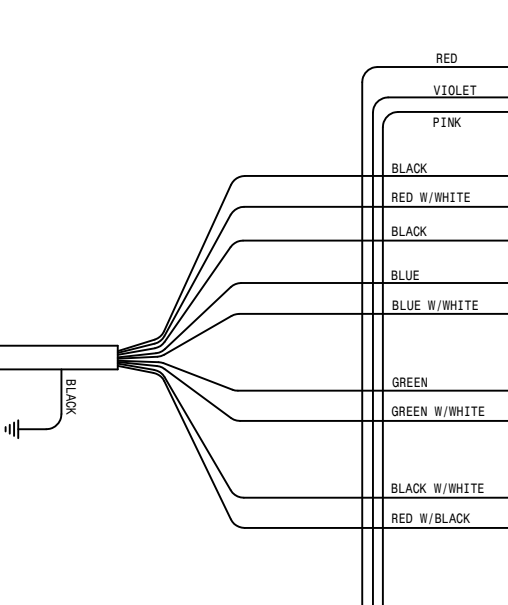
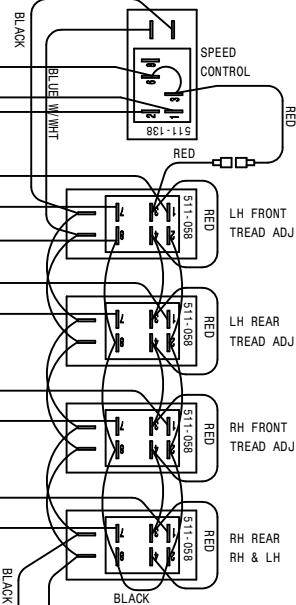

293740 - SOLU TANK VLV HARNESS 2101 03

293738 - CONSOLE, SEAT, TRD ADJ HARNESS 03

293748 - ENG WIRE HARNESS 2101 03 SHEET 1 OF 5

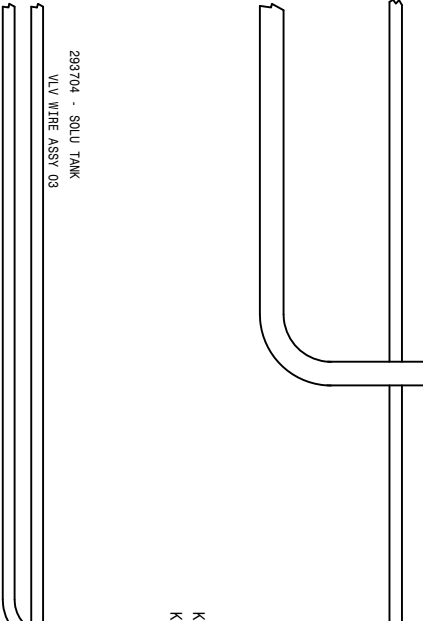
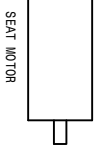
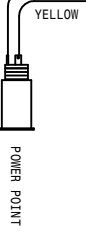

4	1	293499	16GA BRN/YEL-291583-293147-28
3	1	293413	16GA RED-291583-291583-15
2	1	293411	16GA BLK-291511-291583-18
1	1	293423	OND WIRE ASSY, FUSE BOX

DTS10 WIRING DIAGRAM 05
08-30-04 TLM
498871
SHEET 2 OF 5
REVISION DATE: 10-25-04

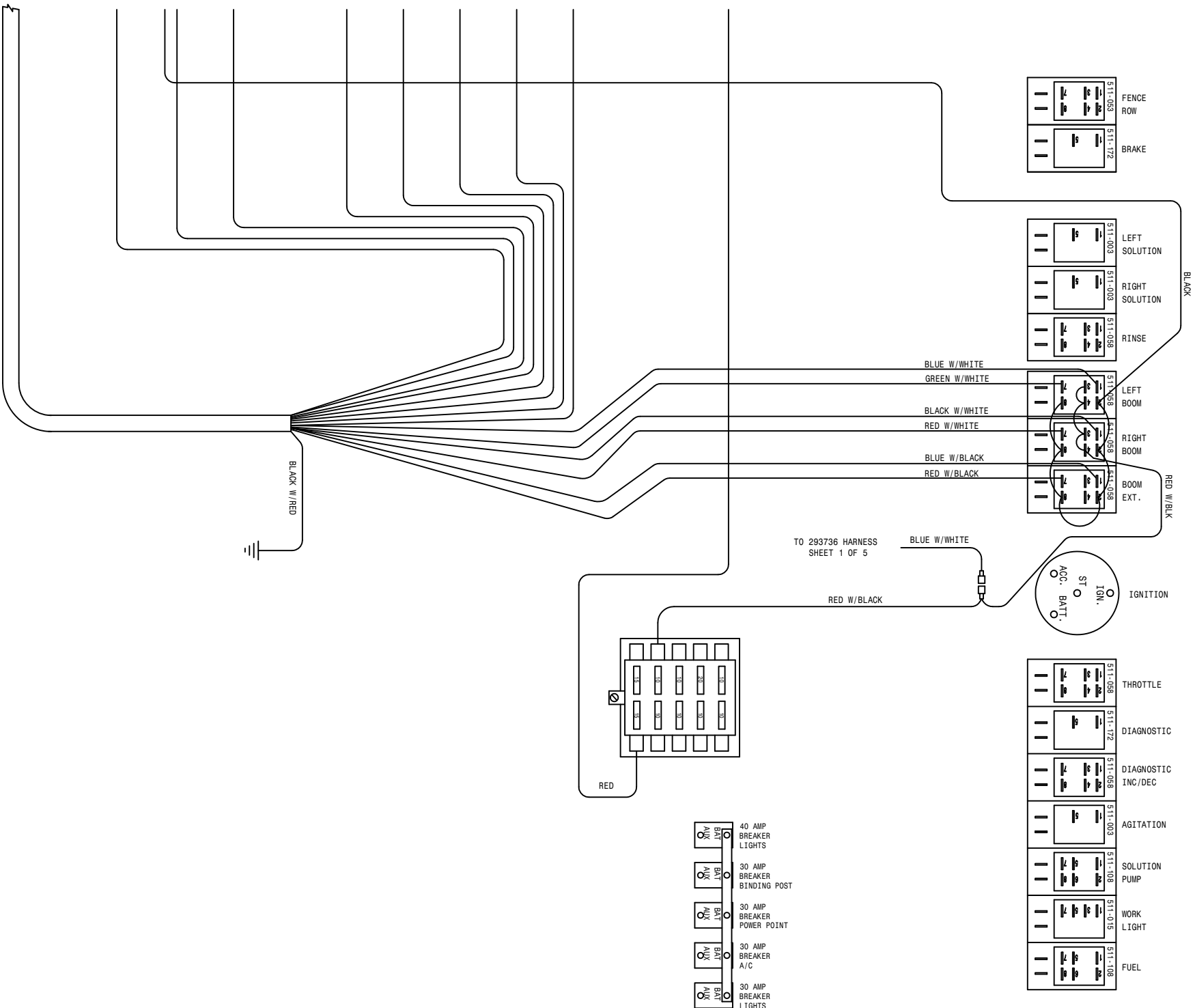

293734 - BOOM CRTL HARNESS, PNL, 2101

- 40 AMP BREAKER LIGHTS
- 30 AMP BREAKER BINDING POST
- 30 AMP BREAKER POWER POINT
- 30 AMP BREAKER A/C
- 30 AMP BREAKER LIGHTS

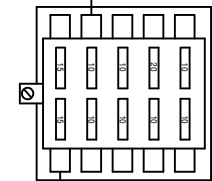

09-30-04 TLM
 DTS 10 WIRING DIAGRAM 05
 SHEET 3 OF 5
 REVISION DATE:
 498871

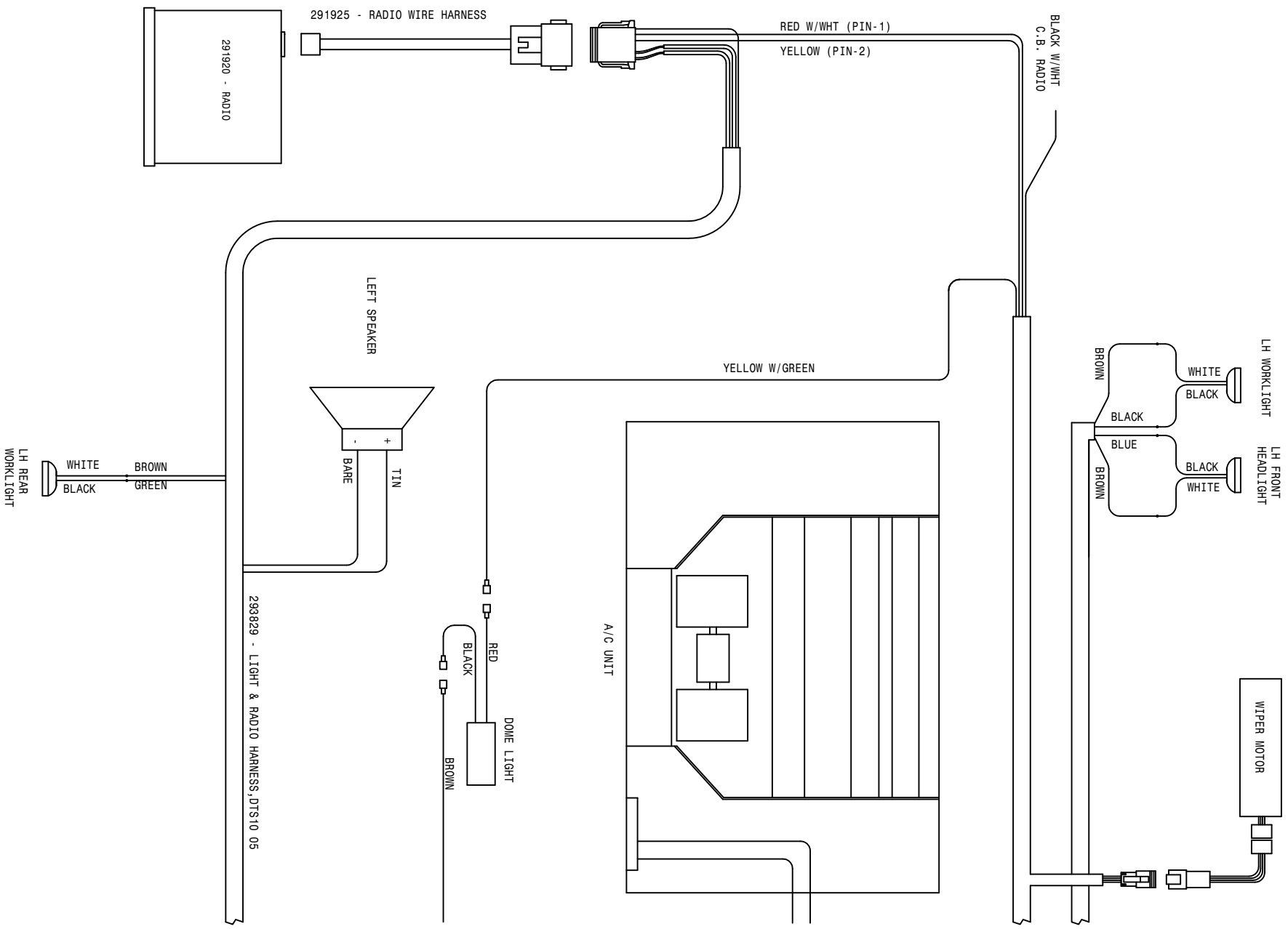

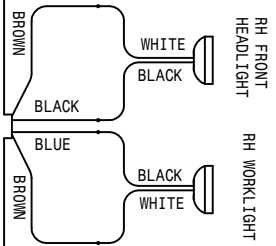

WINDSHIELD WASHER UNIT

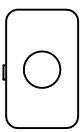

293828 - WINDSHLD WASH HARNESS, DTS10 05

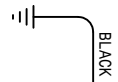

293830 - HEADLIGHT HARNESS, DTS10 05

293831 - CAB WIRE HARNESS, DTS10 05

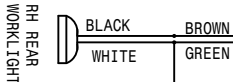
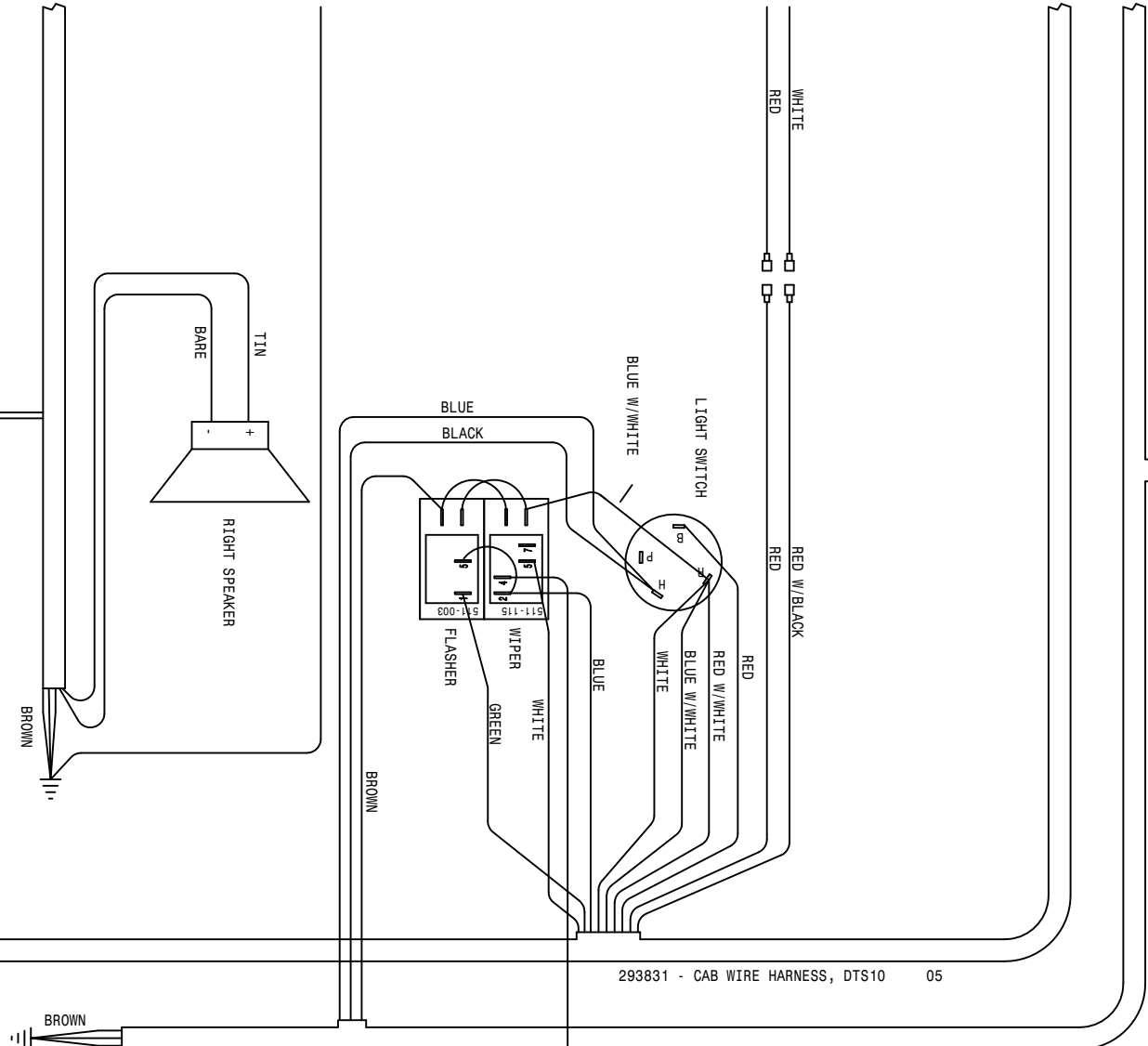

TO WORK LIGHT SWITCH, PORT-3

SHEET 2 OF 5

REFER TO SHEET 1 OF 5

DTS10 WIRING DIAGRAM 05	09-30-04	TUL
SHEET 4 OF 5		
REVISION DATE: 12-16-04		
498871		

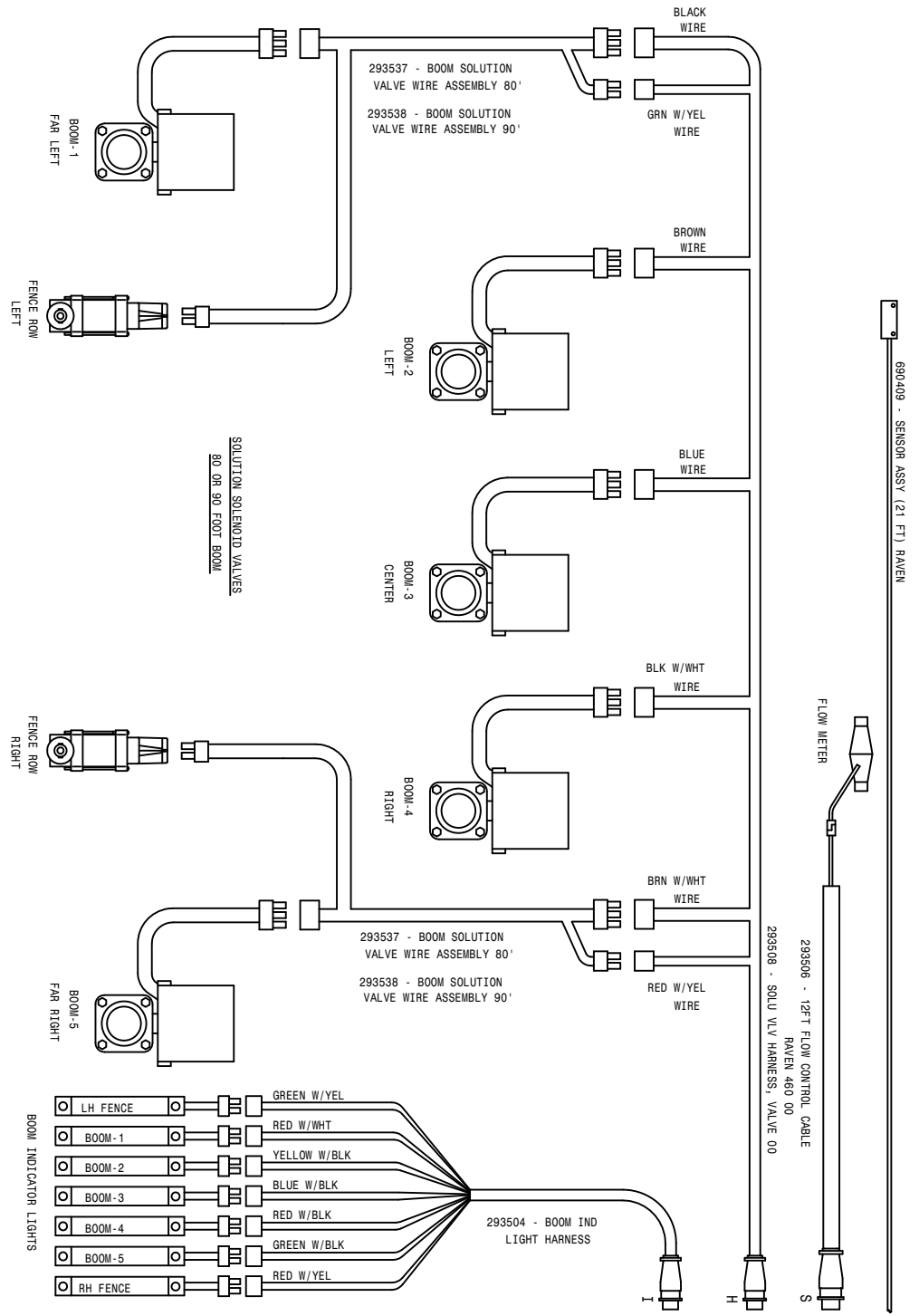
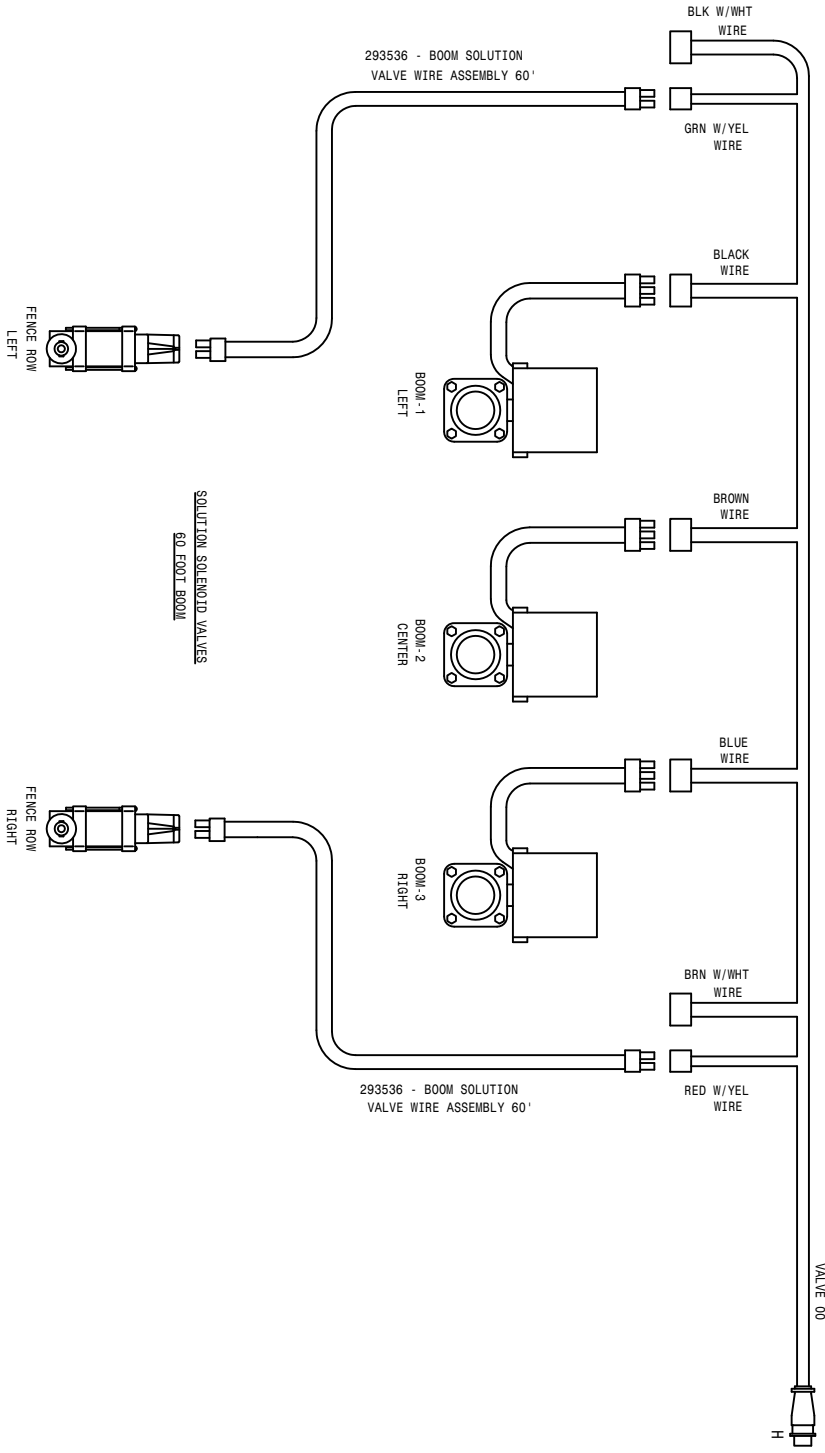

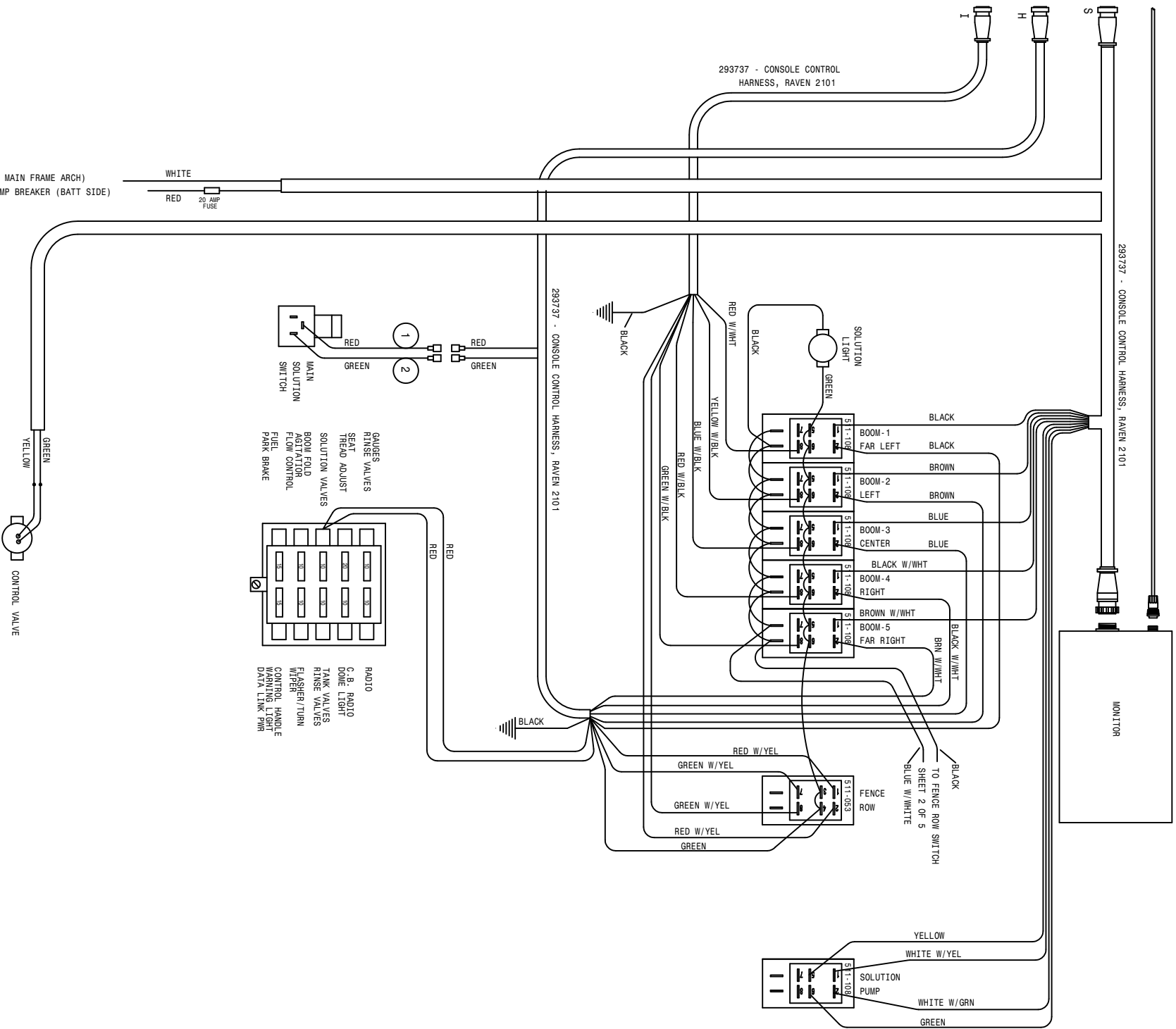

SHEET 1 OF 5

GROUND (MAIN FRAME ARCH)
TO 100 AMP BREAKER (BATT SIDE)

2	1	293283	16GA GRN-291571-291571-45
1	1	293562	16GA RED-291571-291571-45
DTS10 WIRING DIAGRAM 05			
08-30-04 TUL			
SHEET 5 OF 5			
REVISION DATE:			
498871			

ABBREVIATIONS

A/C - AIR CONDITIONER	MT - MOUNT
ADPTR - ADAPTER	MTR - MOTOR
AGI - AGITATOR	P/N - PART NUMBER
ALT - ALTERNATOR	PLT - PLATE
ASSY - ASSEMBLY	QTY - QUANTITY
BRKT - BRACKET	RED - REDUCER
DET - DETAIL	REF - REFERENCE
DISPL - DISPLACEMENT	REST - RESTRICTOR
EL - ELBOW	REQ - REQUIRED
EXT - EXTENSION	SHFT - SHAFT
FLO - FLOW	SOL - SOLUTION
FNPT - FEMALE NATIONAL PIPE THREAD	STRG - STEERING
FOR - FEMALE O-RING	ST - STREET
FRT - FRONT	SWIV - SWIVEL
HYD - HYDRAULIC	UNC - UNIFIED NATIONAL COURSE
HYDRO - HYDROSTATIC	UNF - UNIFIED NATIONAL FINE
LG - LONG	V - VOLT
LWR - LOWER	W/ - WITH
MJIC - MALE J.I.C.	WHL - WHEEL
MOR - MALE O-RING	WLD - WELDMENT

INDEX

-A-

ABBREVIATIONS.....128
ACCUMULATOR CYLINDER..... 81,83,84
AGITATOR
 IMPELLER..... 59,61
 SHAFT..... 59,61
 SHIELD..... 59,61
 SOLUTION..... 59,61
 VARIABLE FLOW CONTROL..... 15
AIR BAG..... 22,24,26,28
AIR CLEANER..... 33
 BAND..... 33
 FILTER..... 33
HOOD..... 33
HOSE..... 33
AIR CONDITIONER..... 36
 BLOWER..... 36
 COMPRESSOR..... 5
 CONDENSOR..... 19
 DRYER..... 19
 EVAPORATOR..... 36
 FILTER..... 36
AIR INTAKE..... 19
AIR LINE..... 9,48
AIR REGULATOR..... 48
AIR SEAT..... 45
AIR TANK..... 8,9
ANTENNA..... 36

-B-

BATTERY..... 56
 BOX..... 56
 CABLE..... 56
 HOLD DOWN..... 56
BEARING, LEG..... 22,24,26,28
BELT..... 4,6
BINDING POST..... 43
BLADE, WIPER..... 34
BLOWER MOTOR..... 36
BOOM..... 89,90,91,92,93
 CONTROL VALVE..... 82
 CRADLE..... 55
 HINGE..... 91,93
 LIGHTS..... 88
SOLENOID..... 62,63,64,65,66,67,68
 SPRING..... 85
BOX FUSE..... 44
BREAKAWAY..... 81
BREAKER CIRCUIT..... 4,44

BUMPER, LEG..... 22,24,26,28

-C-

CAB..... 34
 LIGHTS..... 34,36
CABLE,
 BATTERY..... 56
 GROUND..... 4
 HYDROSTATIC..... 42
CIRCUIT BREAKER..... 4,44
CLAMP,
 AIR CLEANER..... 33
 MUFFLER..... 32,33
CONDENSOR..... 19
CONSOLE..... 40,45
CRADLE
 BOOM..... 55
 SOLUTION TANK..... 58,60
CROP GUIDE..... 23,25,27,29
CYLINDER
 ACCUMULATOR..... 83,84
 FOLD..... 81,87
 LEVEL..... 86
 LIFT..... 85
 STEERING..... 30
 TREAD ADJUST..... 100

-D-

DECALS..... 108,109
DIAGRAMS, WIRING..... 116
DOOR..... 35
 LATCH..... 35
DRAIN VALVE..... 8,9
DRINK HOLDER..... 41
DRIVE DISK..... 5
DYER, A/C..... 19
BELT..... 4,6

-E-

ENGINE..... 4,5
 HOOD..... 46
EXHAUST STACK..... 32

-F-

FAN..... 4
 SPACER..... 4
FEEDER TEE..... 78

FENCE ROW.....71,72
 FILTER,
 AIR CLEANER.....33
 AIR CONDITIONER.....36
 ENGINE.....4
 FUEL.....5
 HYDRAULIC.....11
 MINDER.....46
 FLOW DIVIDER.....14,16
 FLOW METER.....62,63,66,67
 FLUSHING VALVE.....10
 FOAM.....34,37
 FOAMER TANK.....96
 FOAMER VALVE.....105
 FOLD CYLINDER.....87,81
 FRESH WATER TANK.....54
 FUEL,
 SELECTOR VALVE.....52
 STRAINER.....5
 TANK.....52
 TANK MOUNT.....50,51
 FUSE.....44
 BOX.....44

-G-

GAS SPRING.....38,41,46
 GAUGE
 AIR REGULATOR.....48
 OIL PRESSURE.....39
 PRESSURE.....48,62,63,66,67
 TEMPERATURE.....39
 TREAD ADJUST.....53
 GRAB HANDLE.....34
 GLASS.....34,35
 GROUND CABLE.....4
 GROUND STRAP.....34
 GUIDE, STALK.....23,25,27,29

-H-

HANDLE,
 DOOR.....35
 GRAB.....34
 HANDRAIL.....53
 HEADLIGHT.....34,57,80
 HEADLINER.....36
 HEATER COIL.....36
 HINGE, BOOM.....91,93
 HOOD,
 AIR CLEANER.....33
 ENGINE.....46
 HOOK, RUBBER.....39
 HOSE, RADIATOR.....4
 HOISING, SOLUTION.....74,75,76,77
 HOUR METER.....39
 HUB, TORQUE.....23

HYDRAULIC
 DAMPER.....35
 FILTER.....11
 SOLENOID VALVE.....12
 SCHEMATIC.....110
 TANK.....20
 HYDROSTATIC
 CABLE.....42
 LEVER.....42

-I-

IGNITION SWITCH.....43
 INJECTION PLATFORM.....104
 INSTRUMENT PANEL.....39

-L-

LADDER.....50,51
 LATCH, DOOR.....35
 LEG,
 BEARING.....22,24,26,28
 BRACE.....57
 BUMPER.....22,24,26,28
 FRONT.....22,24
 REAR.....26,28
 LEVEL CYLINDER.....81
 LEVER,
 HYDROSTATIC.....42
 LIFTARM.....80
 LIFT CYLINDER.....85
 LIGHT,
 BOOM.....88
 CAB.....34,36
 SWITCH.....36

-M-

MIRROR.....34
 MONITOR, FLOW MAX 110.....106
 MOTOR
 BLOWER.....36
 STEERING.....38
 WHEEL.....23,25,27,29
 WIPER.....34
 MOUNT,
 CAB.....34
 MOTOR.....4,5
 PUMP.....7
 MUFFLER.....32
 CLAMP.....32,33
 MULLION.....45

-N-

NOZZLE, REAR WHEEL.....73
 NOZZLE, RINSE.....95

-0-
OIL
COOLER.....19
PRESSUR.....39
SENDER.....5
TANK.....20

-P-
PAD, RADIATOR.....19
PANEL, SWITCH.....43
PLATFORM, INJECTION.....104
POWER POINT.....45
PRESSURE
GAUGE.....43,62,63,66,67
WASHER.....101
PUMP,
SOLUTION.....95
SUNDSTRAND.....7

-Q-
QUICK FILL.....70

-R-
RADAR.....103
RADIATOR.....19
HOSE.....4
PAD.....19
RECOVERY TANK.....49
SHROUD.....19
RADIO.....36
RAVEN, VFC.....17
REAR WHEEL NOZZLE.....73
RELAY.....44
RELIEF VALVE.....14
RETURN TEE ASSEMBLY.....18
RIM.....21
RINSE
NOZZLE.....95
TANK.....94
RUBBER,
HOOK.....46
MOUNT.....4,5,7,34

-S-
SCHEMATIC, HYDRAULIC.....110
SEAT.....45
SENDER,
OIL.....5
TEMPERATURE.....4
SERVICE PLATFORM.....53

SHEET METAL.....46,47
SHIELD, TANK.....57
SHROUD, RADIATOR.....19
SIDERAIL.....53
SNV SIGN.....53
SOLENOID, BOOM .62,63,64,65,66,67
SOLUTION
HOSING.....74,75,76,77
PUMP.....79
TANK CRADLE.....58,60
SPACER, FAN.....4
SPEAKER.....36
SPRING, GAS.....38,41,38
STALK GUIDE.....23,25,27,29
STEERING
COLUMN.....38
CYLINDER.....38
MOTOR.....38
WHEEL.....38
STRAINER,
FUEL.....5
SOLUTION.....58,60
STRAP, GROUND.....34
SUNDSTRAND PUMP.....7
SWITCH,
IGNITION.....43
LIGHT.....43
PANEL.....43
SOLUTION.....34

-T-
TAILLIGHT.....53
TANK,
AIR.....8,9
FOAMER.....96
FRESH WATER.....54
HYDRAULIC.....20
MOUNTS.....57
RADIATOR RECOVERY.....49
RINSE.....92
SHIELD.....57
SOLUTION.....58,60
TEE, FEEDER.....78
TEMPERATURE
GAUGE.....39
SENDER.....4
TIE PLATE.....13
TIE ROD.....31
TIRE.....21
TRANSOM.....75
TREAD ADJUST.....99
CYLINDER.....100
GAUGE.....53
VALVE.....98
TORQUE, HUB.....23,25,27,29

VALVE,
AIRBAG.....23,24,26,28
DIVERT, FOAMER.....105
DRAIN.....8
ELECTRIC BOOM.....82
FENCE ROW.....71,72
FLUSHING.....10
FUEL SELECTOR.....52
HYDRAULIC SOLENOID.....12
RELIEF.....14
TREAD ADJUST.....98
VARIABLE FLOW CONTROL.13,15,17
VOLT METER.....39

WASHER, PRESSURE.....101
WHEEL MOTOR.....23,25,27,29
WHEEL, STEERING.....38
WINDSHIELD WASHER.....107
WIPER,
BLADE.....34
MOTOR.....34
WINDSHIELD.....34