

**PARTS MANUAL**  
**FOR**  
**HAGIE MODEL 284 XP HI-TRACTOR**

**HAGIE MANUFACTURING COMPANY**

BOX 273 CLARION, IOWA 50525 (515) 532-2861

COVERS MACHINE SERIAL NUMBERS: U1210440001 thru U1210440100

12-03 493298  
02-08

SPRAYER IDENTIFICATION

Each Hagie sprayer is identified by means of a frame serial number. This serial number denotes the model, the year in which it was built, and the number of the sprayer. As for further identification, the engine has a serial number and the planetary hubs have identification plates that describe the type of mount and gear ratio. To insure prompt, efficient service when ordering parts or requesting service repairs from Hagie Manufacturing Company, record the serial and identification numbers in the space provided below.

NOTE: Reference to left hand and right hand used throughout this manual refers to the position when seated in the operator's seat facing forward.

SPRAYER SERIAL NUMBER

\_\_\_\_\_

ENGINE SERIAL NUMBER

\_\_\_\_\_

PLANETARY HUB IDENTIFICATION NUMBERS

\_\_\_\_\_

TABLE OF CONTENTS

ENGINE ASSEMBLIES . . . . .	.4-6
FLOW DIVIDER . . . . .	.7
AIR TANK ASSEMBLY . . . . .	8-9
FLUSHING VALVE . . . . .	10-11
A/C AND RADIATOR . . . . .	12-13
AIR CLEANER AND EXHAUST PIPE . . . . .	14
BATTERY . . . . .	15
HYDRAULIC TANK . . . . .	16
LEG ASSEMBLIES . . . . .	17-25
STEERING CYLINDER AND TIE ROD . . . . .	26-27
CAB ASSEMBLY . . . . .	28-32
INSTRUMENT PANEL ASSEMBLY . . . . .	33
SWITCH PANEL ASSEMBLY . . . . .	34
CONSOLE ASSEMBLY . . . . .	35-37
BRAKE SOLENOID AND SEAT . . . . .	38-40
SELECTOR VALVE AND VFC . . . . .	41-42
BOOM CRADLE . . . . .	43
SHEET METAL . . . . .	44-45
LADDER AND FUEL TANK . . . . .	46-48
SERVICE PLATFORM ASSEMBLY . . . . .	49
FOAMER TANK . . . . .	50-52
RINSE TANK . . . . .	53-54
SOLUTION TANK . . . . .	55-59
SOLUTION SYSTEM (STANDARD VOLUME) . . . . .	60-63
SOLUTION HOISING . . . . .	64-67
SOLUTION SYSTEM (HI-VOLUME) . . . . .	68-71
FENCE ROW . . . . .	72-73
WINDSHIELD WASHER . . . . .	74
BOOM VALVE . . . . .	75
TRANSOM, BOOM, AND LIFT COMPONENTS . . . . .	76-88
REAR WHEEL NOZZLE OPTION . . . . .	89
TREAD ADJUSTMENT OPTION . . . . .	90-92
PRESSURE WASHER OPTION . . . . .	93-94
RADAR OPTION . . . . .	95
DECALS . . . . .	96-97
HYDRAULIC SCHEMATIC . . . . .	98-103
ELECTRICAL SCHEMATIC . . . . .	104-113
ABBREVIATIONS . . . . .	114
INDEX . . . . .	115

ENGINE ASSEMBLY

DET.	QTY	PART NO.	DESCRIPTION
1	1	193012	QUICKEDGE TRIM .135 TO .250
2	1	290107	GROUND CABLE,8" X 4GA .406LUGS
3	1	291674	OIL PRESS SENDER,125PSI,1/8NPT
4	1	316252	RH REAR ENG MT WLD, CUMM 94
5	1	316253	LH REAR ENG MT WLD, CUMM 94
6	1	316517	THROTTLE CABLE MT WLD, CUMM 02
7	1	316516	THROTTLE CABLE LEVER, CUMM 02
8	1	316312	CUMM ENG,6B5.9A 152@2500 CMPSR
9	1	316320	HYDST CABLE MT WLD,284 CUMM 98
10	1	500900	BLK PIPE ST EL 90DEG .125NPT
11	8	473775	12MM-1.75 X 30MM HEX BOLT
12	12	473784	12MM LOCK WASHER
13	2	473826	6MM-1.00 X 16MM HEX BOLT
14	2	473828	12MM-1.50 X 20MM HEX BOLT
15	2	473783	12MM-1.75 X 25MM HEX BOLT
16	1	610300	3/4MJIC-3/4MNPT ADPTR
17	1	473804	8MM LOCK WASHER
18	1	473827	8MM-1.25 X 20MM HEX BOLT
19	1	711036	1/8MNPT-1/4 NYL TUBE FTG
20	1	800501	DRIVE DISK ASSY, 284
21	8	473793	10MM-1.50 X 20MM HEX BOLT
22	12	473792	10MM-1.50 X 30MM HEX BOLT
23	2	473768	6MM LOCK WASHER
24	2	311054	RUBBER MOUNT SET, CB-2202-4
25	2	311055	REBOUND WASHER FOR 311054
26	1	520055	HOSE CLAMP NO 12 STAINLESS
27	4	520120	HOSE CLAMP NO 4 STAINLESS
28	1	316281	FUEL STRAINER, IN-LINE, DIESEL
29	1	601347	HOSE, 3/8 X 10 FUEL LINE
30	1	473921	BALL JOINT NO 10-32 THD
31	20	473798	10MM LOCK WASHER
32	2	910027	10-32 HEX NUT
33	1	785066	CTRL CABLE 10-32 4IN X 129 IN
34	1	316208	FUEL FILTER, PRIMARY CUMM 92
35	1	316209	FUEL FILTER, SECONDARY CUMM92
36	2	900271	1/2UNC X 3 1/4 HEX BOLT
37	2	914008	1/2UNC HEX STOVER NUT
38	4	920004	1/2 SAE FLAT WASHER
39	1	914027	10-32 HEX STOVER NUT
40	2	920510	#10 LOCK WASHER
41	1	903893	10-32 X 1" SLT RD HD MACH SCR
42	1	601619	HOSE, 1/4 X 27 AIR

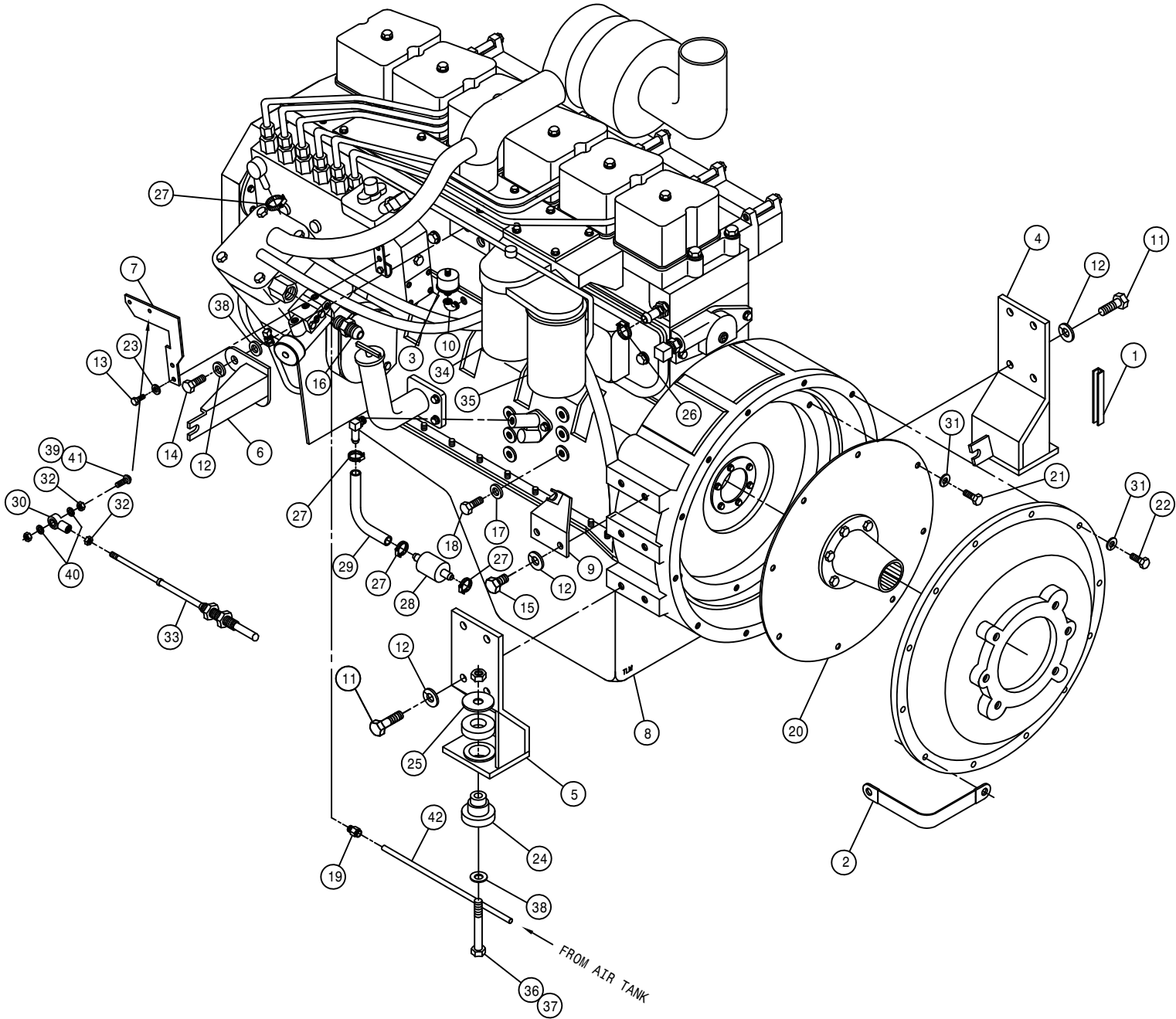

4

ENGINE ASSEMBLY

DET. QTY PART NO. DESCRIPTION

1	1	193012	QUICKEDGE TRIM .135 TO .250
2	1	291197	CIRCUIT BREAKER,30AMP,INLINEMT
3	1	291556	CIRCUIT BREAKER,50AMP,INLINEMT
4	1	314832	RADIATOR HOSE 1.75 X 19(52423)
5	1	314836	TEMP SENDR 280D 1/2NPT FOR GA
6	1	316180	FAN, 22" 6 BLADE 30DEG 2.25PIT
7	1	316199	22IN FAN SPACER CUMM 92
8	1	316250	RH FRT ENG MT WLD, CUMM 94
9	1	316312	CUMM ENG,6B5.9A 152@2500 CMPSR
10	1	316313	LH FRT ENG MT WLD, 284 CUMM 98
11	1	316339	BREAKER MTG PLT, 2100 98
12	1	316340	BREAKER COVER, 2100 98
13	4	470175	10-32 HEX FLANGE LOCK NUT
14	2	470216	10-32 X 3/4 FLANGE HEX BOLT
15	6	473775	12MM-1.75 X 30MM HEX BOLT
16	2	473782	12MM-1.75 X 18MM HEX BOLT
17	8	473784	12MM LOCK WASHER
18	4	473804	8MM LOCK WASHER
19	4	473822	8MM-1.25 X 70MM HEX BOLT
20	2	520067	HOSE CLAMP NO 28 STAINLESS
21	1	618573	5/8 HOSE BARB-90-1/2MNPT
22	4	903812	6-32 X 1/2 SLT RD HD MACH SCR
23	8	910022	6-32 HEX NUT
24	6	910027	10-32 HEX NUT
25	2	311053	RUBBER MOUNT SET,SSB26-1000-1
26	1	314886	RADIATOR HOSE 2 1/4 20717
27	1	470118	1/4UNC X 3/4 FLANGE HEX BOLT
28	1	470121	1/4UNC HEX FLANGE LOCK NUT
29	4	900265	1/2UNC X 1 1/2 HEX BOLT
30	1	520055	HOSE CLAMP NO 12 STAINLESS
31	2	900271	1/2UNC X 3 1/4 HEX BOLT
32	6	914008	1/2UNC HEX STOVER NUT
33	6	920004	1/2 SAE FLAT WASHER
34	1	520126	CUSH HOSE CLAMP 2IN X 5/8W
35	2	520099	HOSE CLAMP NO 40 STAINLESS
36	1	316206	POLY V BELT CUMMINS DIESEL 92
37	1	316207	LUBE FILTER CUMMINS DIESEL 92
38	1	341968	TIE PLT 250/280 CUMM 92
39	1	316367	DELCO ALTERNATOR,130 AMP 22SI
40	1	316216	STARTER FOR CUMM 6 CYL 316185
41	1	291852	RELAY, 40 AMP, VF4 SERIES
42	1	903883	10-32 X 1/2 SLT RDHD MACH SCR

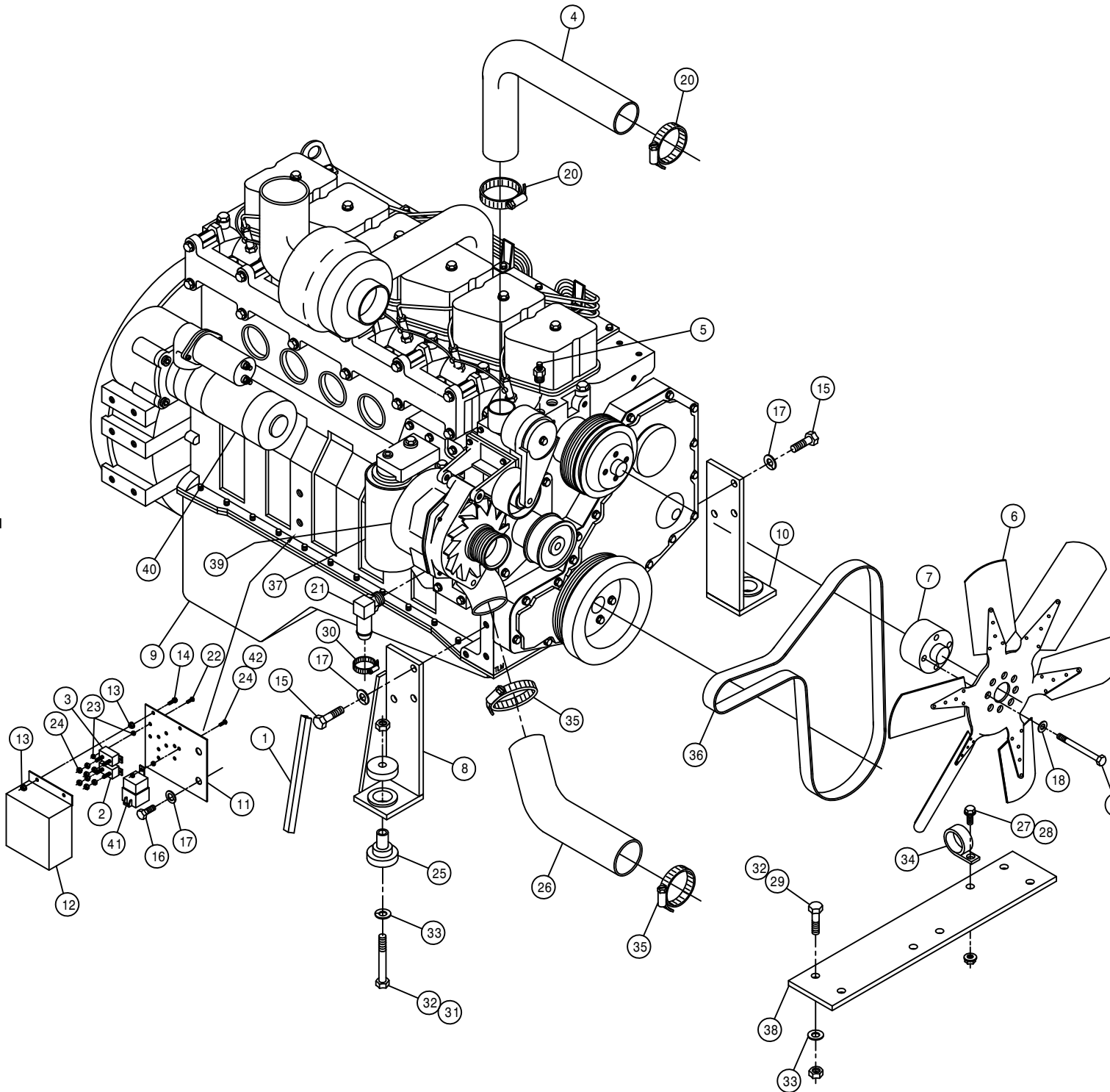

HYDROSTATIC PUMP ASSEMBLY

DET.	QTY	PART NO.	DESCRIPTION
1	1	316319	PUMP CTRL LEVER EXT,284 CUMM98
2	2	618541	1 5/16FJIC-1 1/16MJIC ADPTR
3	2	505101	BLK PIPE TEE 1.00NPT
4	2	505105	1MNPT HEX PIPE NIPPLE STL
5	1	505200	BLK PIPE ST EL 90DEG 1.00NPT
6	1	505213	RED BUSH 1 X 3/4 BLK MAL
7	2	520137	1.12/1.25 T-BOLT HOSE CLAMP
8	1	601399	HOSE, 3/4 X 13 1FBR-1SPI
9	1	606941	TANDEM PUMP, 606929 & 606932
10	1	606929	SUND GEAR PUMP .66CI, SPLINED
11	1	606932	SUND GEAR PUMP,1.60CI,SPLINED
12	1	606954	SUND 130CC PUMP,B-MT 98
13	1	610300	3/4MJIC-3/4MNPT ADPTR
14	1	611128	7/8MJIC-90-7/8MOR LBO
15	1	618075	3/4 HOSE BARB-1 1/16MOR
16	1	618090	1 5/16MOR-1FNPT ADPTR
17	3	618126	9/16MJIC-9/16MOR ADPTR
18	2	618327	3/4MJIC-7/8MOR ADPTR
19	1	618328	7/8FJIC CAP NUT
20	1	618333	7/8FJIC SW RUN TEE-7/8MJIC
21	2	618459	1 1/4FLANGE-90-1 5/8MJIC
22	2	618461	1 1/4 SPLIT FLANGE KIT
23	2	870222	NEO ORING 1 1/2 X 1 3/4
24	1	618486	9/16FJIC SW RUN TEE-9/16MJIC
25	3	618514	9/16FJ SW BRANCH TEE-9/16MJ
26	3	618531	9/16FJIC CAP NUT
27	1	618535	7/8MJIC-90-1 1/16MOR LBO
28	2	618547	1 5/8FJIC-1 5/16MJIC ADPTR
29	1	618564	1IN HOSE BARB-90-1 5/16MOR
30	2	618609	3/4MJIC-90-3/4FJIC SWIV LBO
31	1	618618	9/16MJIC-90-9/16FJIC SWIV LBO
32	4	618619	1 5/16FJ SW RUN TEE-1 5/16MJ
33	1	618626	1 1/4 HOSE BARB-45-1 5/8MOR
34	2	618630	1 5/16MJ-45-1 5/16FJ SWIV LBO
35	2	618640	1 5/16MJ-90-1 5/16FJ SWIV LBO
36	1	714560	1NPT X 1 HOSE BARB
37	1	716000	3/4 HOSE BARB-90-1MNPT
38	2	900003	1/4UNC X 1" HEX BOLT
39	4	900401	3/4UNC X 1 1/2 HEX BOLT
40	1	903893	10-32 X 1" SLT RD HD MACH SCR
41	2	914000	1/4UNC HEX STOVER NUT
42	2	910027	10-32 HEX NUT
43	3	920510	#10 LOCK WASHER
44	4	920006	3/4 SAE FLAT WASHER
45	1	785062	CTRL CABLE 10-32 4IN X 120 LG
46	1	473921	BALL JOINT NO 10-32 THD
47	1	914027	10-32 HEX STOVER NUT
48	1	520132	1.62/1.87 T-BOLT HOSE CLAMP
49	2	520138	1.38/1.56 T-BOLT HOSE CLAMP
50	1	606870	O-RING FOR 606865 SUND B-MT
51	1	606924	O-RING FOR SUND A-MT

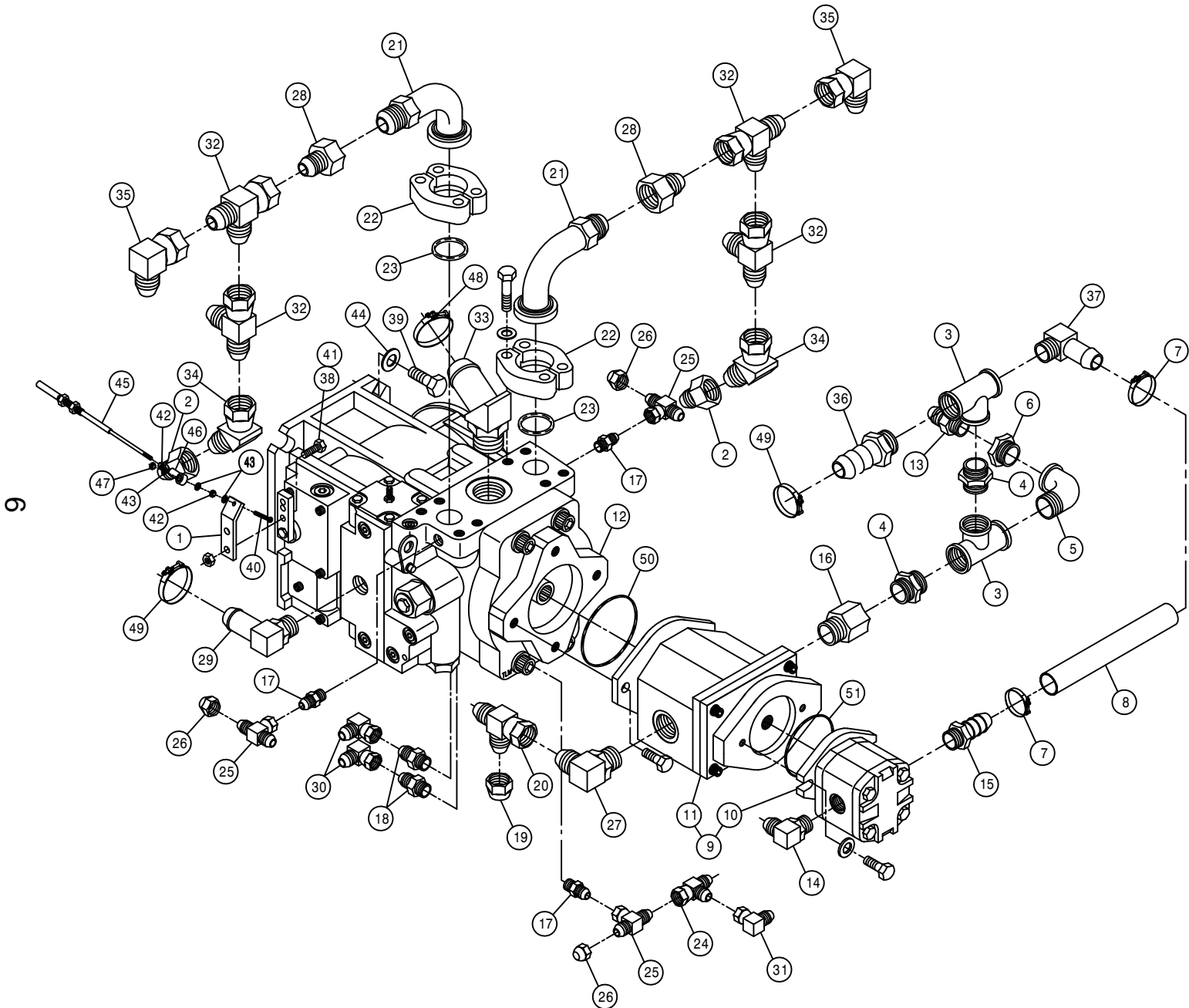

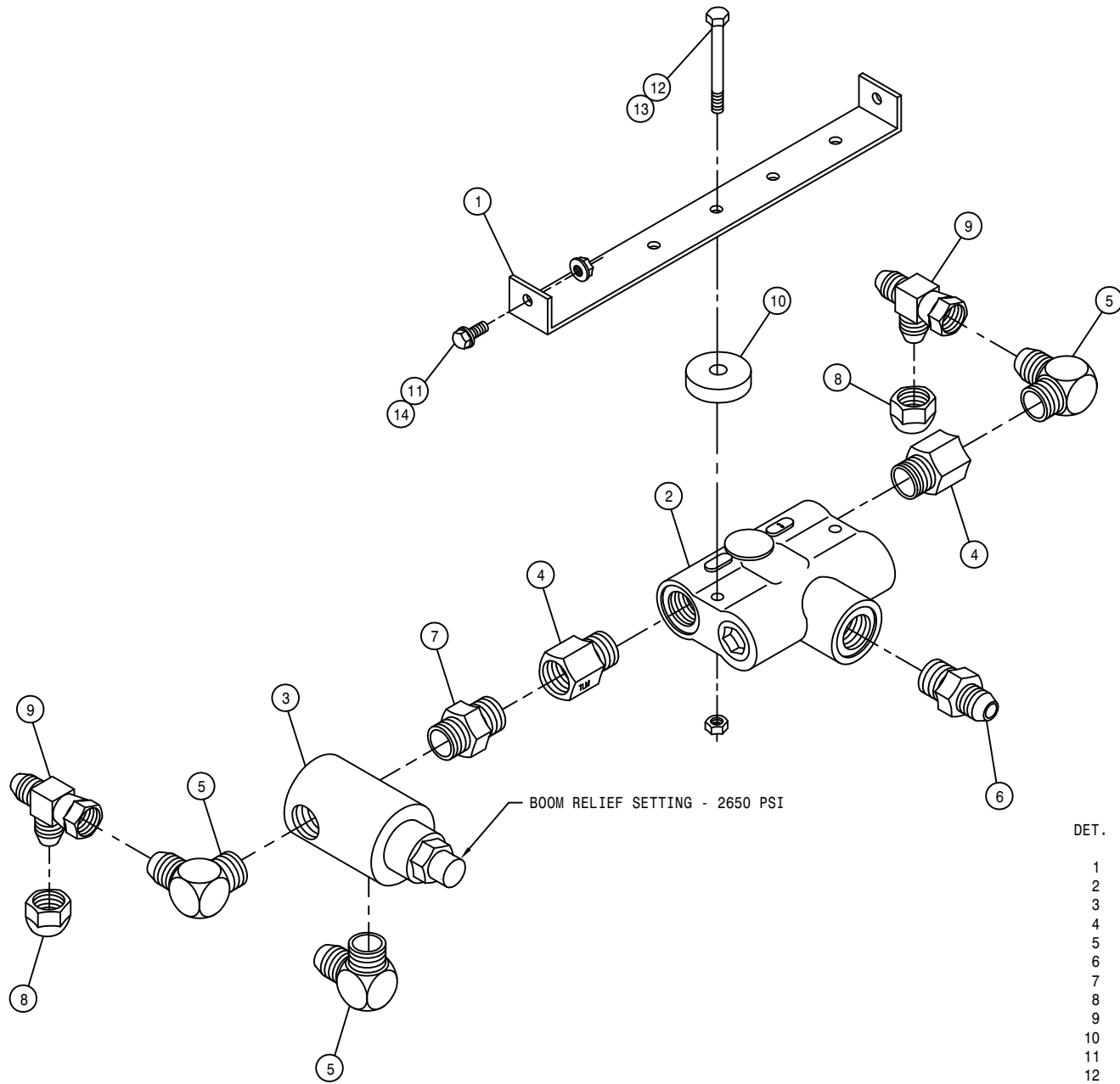

FLOW DIVIDER ASSEMBLY

DET.	QTY	PART NO.	DESCRIPTION	
1	1	341774	FLOW DIVIDER MT 280	89
2	1	610307	FLO DIV BG53 3GPM PRI 7/8FOR	
3	1	607512	RELIEF VALVE, RL50, 1850 PSI	
4	2	618072	7/8MOR-1/2FNPT ADPTR	
5	3	618107	9/16MJIC-90-1/2MNPT LBO	
6	1	611126	7/8MJIC-7/8MOR ADPTR	
7	1	500000	1/2MNPT HEX PIPE NIPPLE STL	
8	2	618531	9/16FJIC CAP NUT	
9	2	618486	9/16FJIC SW RUN TEE-9/16MJIC	
10	2	748500	RUBER WASH 3/8X1/4IDX1 1/2 OD	
11	2	470118	1/4UNC X 3/4 FLANGE HEX BOLT	
12	2	900008	1/4UNC X 2 1/2 HEX BOLT	
13	2	914000	1/4UNC HEX STOVER NUT	
14	2	470121	1/4UNC HEX FLANGE LOCK NUT	

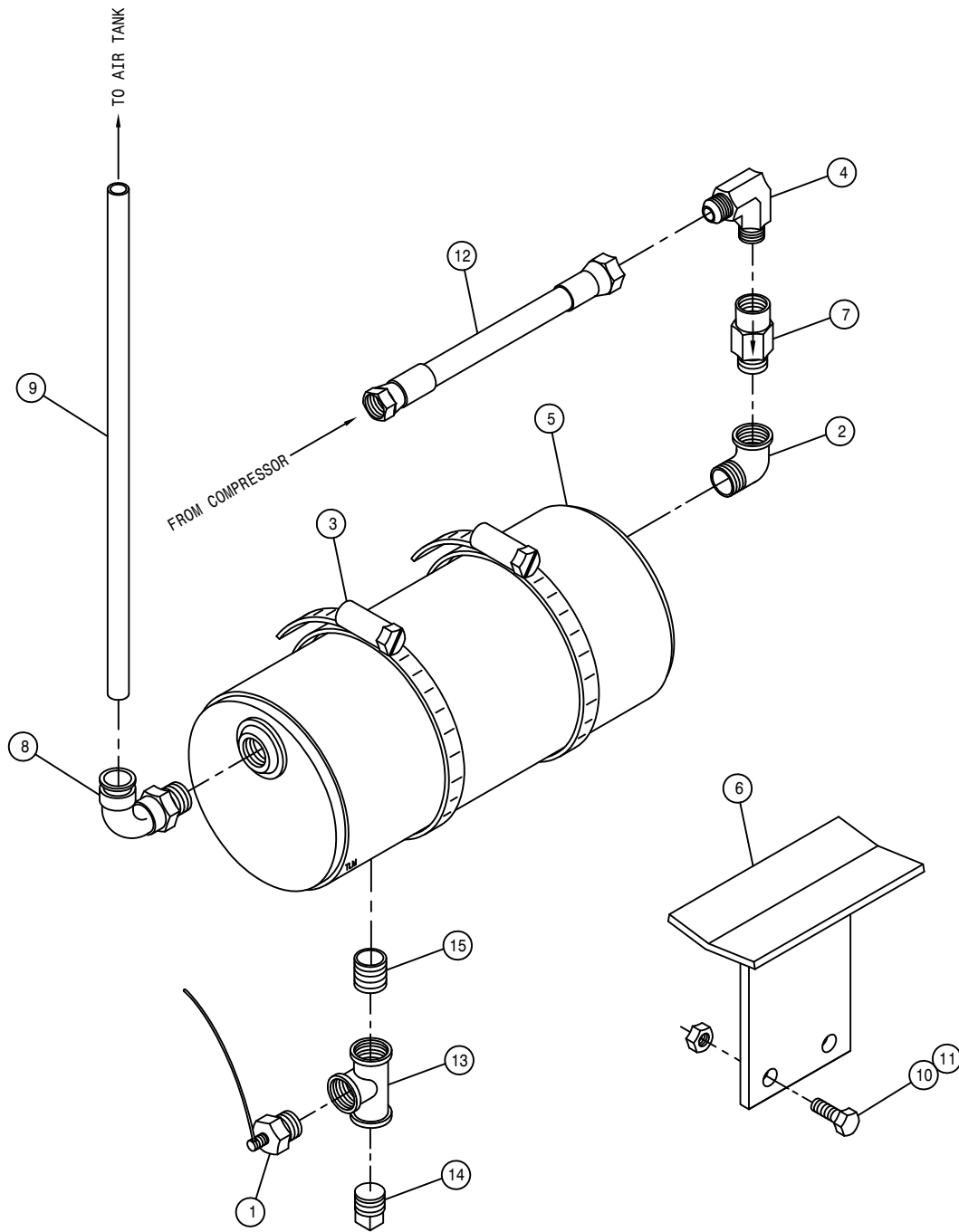

AIR WET TANK ASSEMBLY

DET.	QTY	PART NO.	DESCRIPTION	
1	1	470266	DRAIN VALVE KIT, 1/4NPT	
2	1	503400	BLK PIPE ST EL 90DEG .50NPT	
3	2	520086	HOSE CLAMP NO 88 STAINLESS	
4	1	611145	3/4MJIC-90-1/2MNPT LBO	
5	1	701115	WET TANK WLD	98
6	1	701146	WET TANK MTG BRKT WLD, 284	99
7	1	711032	CHECK VALVE, 1/2"FNPT-1/2"MNPT	
8	1	711042	1/2MNPT-1/2 NYL TUBE LBO	
9	1	601441	HOSE, 1/2 X 20 AIR	
10	2	900129	3/8UNC X 1" HEX BOLT	
11	2	914004	3/8UNC HEX STOVER NUT	
12	1	611301	08P919-08FJX-08FJX-18	H/A
13	1	501101	BLK PIPE TEE .25NPT	
14	1	501102	1/4 PIPE PLUG	
15	1	501601	CLOSE NIPPLE .25NPT	



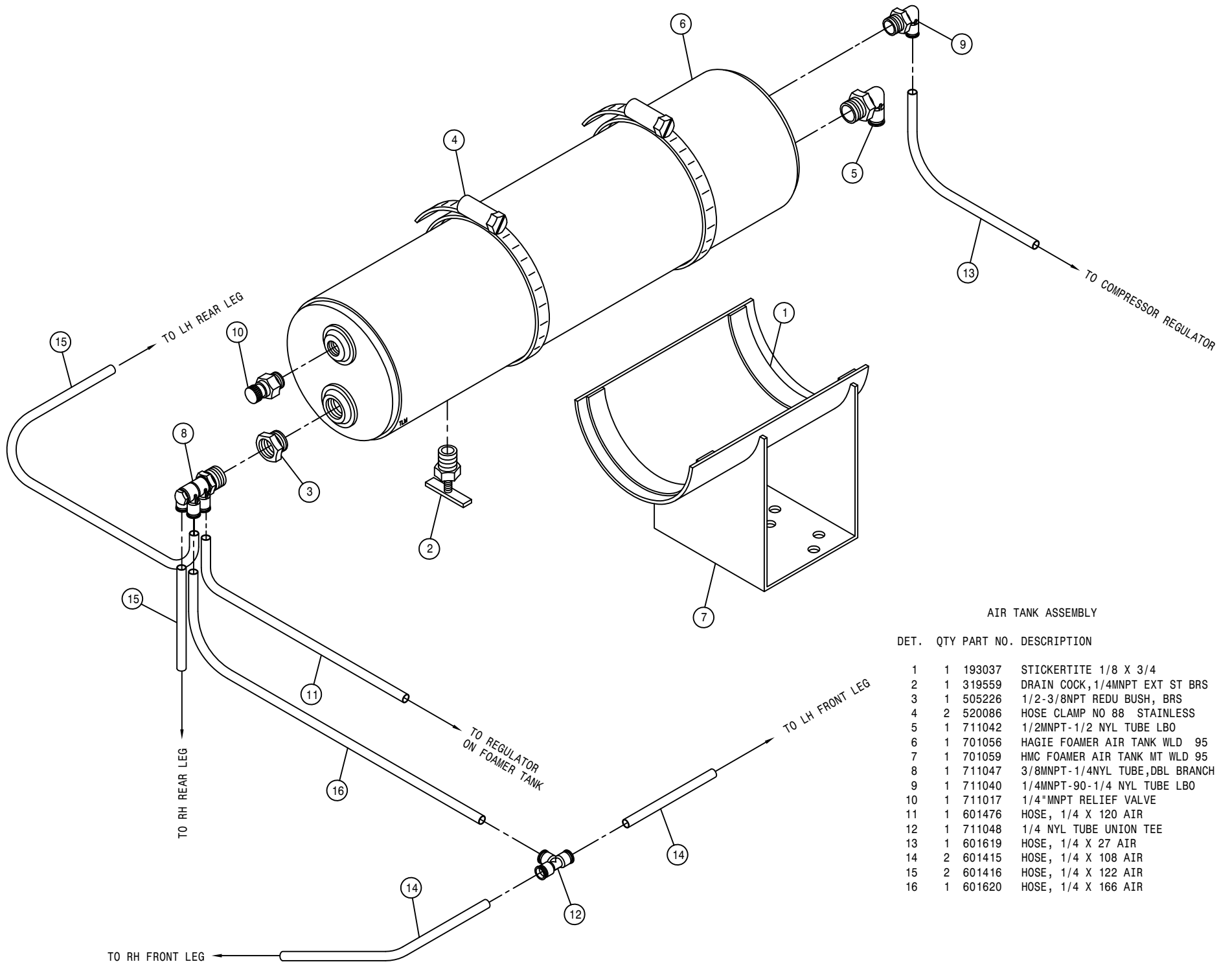

AIR TANK ASSEMBLY

DET.	QTY	PART NO.	DESCRIPTION
1	1	193037	STICKERTITE 1/8 X 3/4
2	1	319559	DRAIN COCK, 1/4MNPT EXT ST BRS
3	1	505226	1/2-3/8NPT REDU BUSH, BRS
4	2	520086	HOSE CLAMP NO 88 STAINLESS
5	1	711042	1/2MNPT-1/2 NYL TUBE LBO
6	1	701056	HAGIE FOAMER AIR TANK WLD 95
7	1	701059	HMC FOAMER AIR TANK MT WLD 95
8	1	711047	3/8MNPT-1/4NYL TUBE, DBL BRANCH
9	1	711040	1/4MNPT-90-1/4 NYL TUBE LBO
10	1	711017	1/4"MNPT RELIEF VALVE
11	1	601476	HOSE, 1/4 X 120 AIR
12	1	711048	1/4 NYL TUBE UNION TEE
13	1	601619	HOSE, 1/4 X 27 AIR
14	2	601415	HOSE, 1/4 X 108 AIR
15	2	601416	HOSE, 1/4 X 122 AIR
16	1	601620	HOSE, 1/4 X 166 AIR

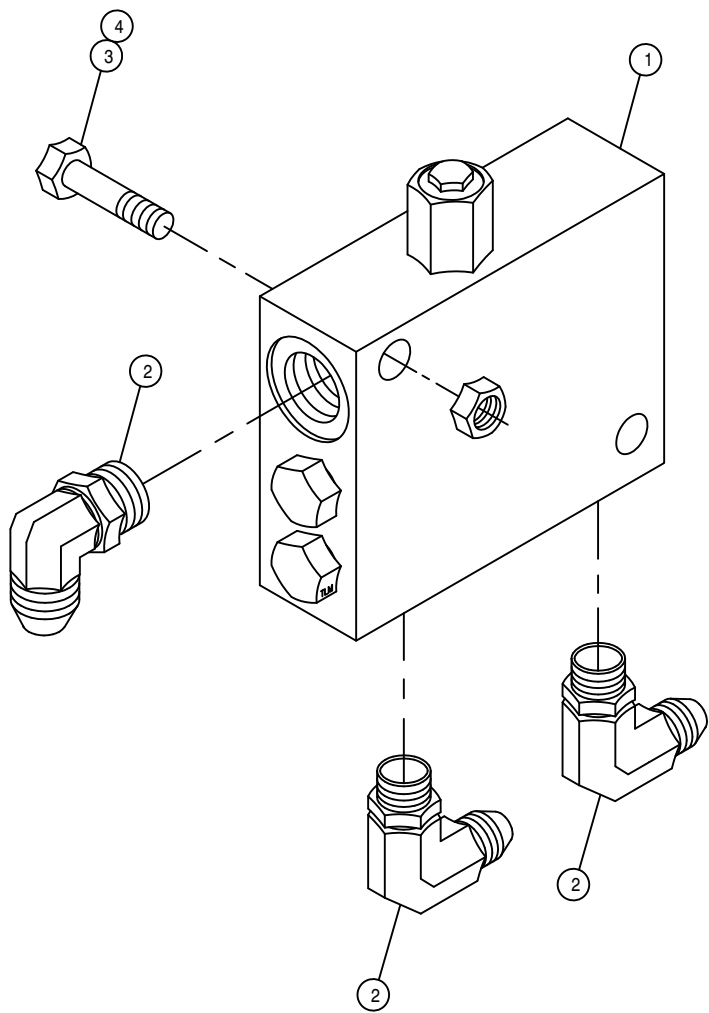

LOOP FLUSHING VALVE ASSEMBLY

DET.	QTY	PART NO.	DESCRIPTION
1	1	610580	REMOTE FLUSHING VALVE, SUND
2	3	618119	9/16MJIC-90-9/16MOR LBO
3	2	900133	3/8UNC X 2" HEX BOLT
4	2	914004	3/8UNC HEX STOVER NUT

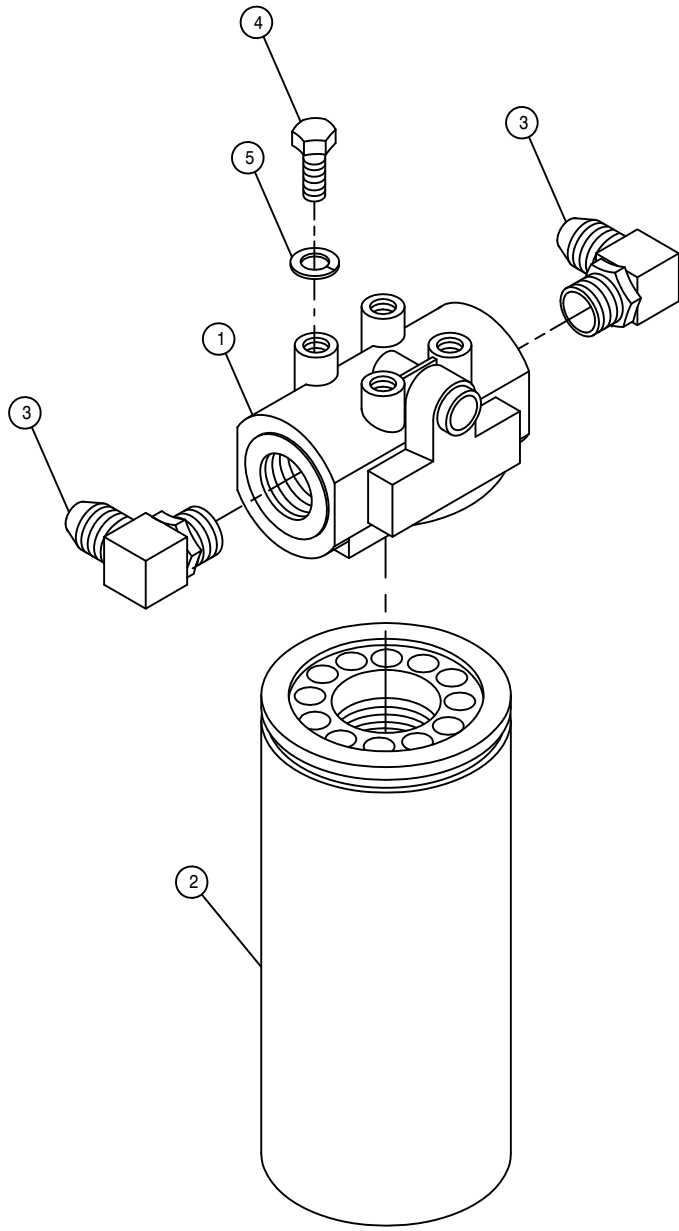

HI-PRESS FILTER ASSEMBLY

DET.	QTY	PART NO.	DESCRIPTION
1	1	605608	HYD FILTER HEAD, DONALDSON
2	1	605609	HYD FILTER ELEMENT, DONALDSON
3	2	618474	3/4MJCIC-90-1 1/16MOR LBO
4	4	900128	3/8UNC X 3/4 HEX BOLT
5	4	920502	3/8 LOCK WASHER

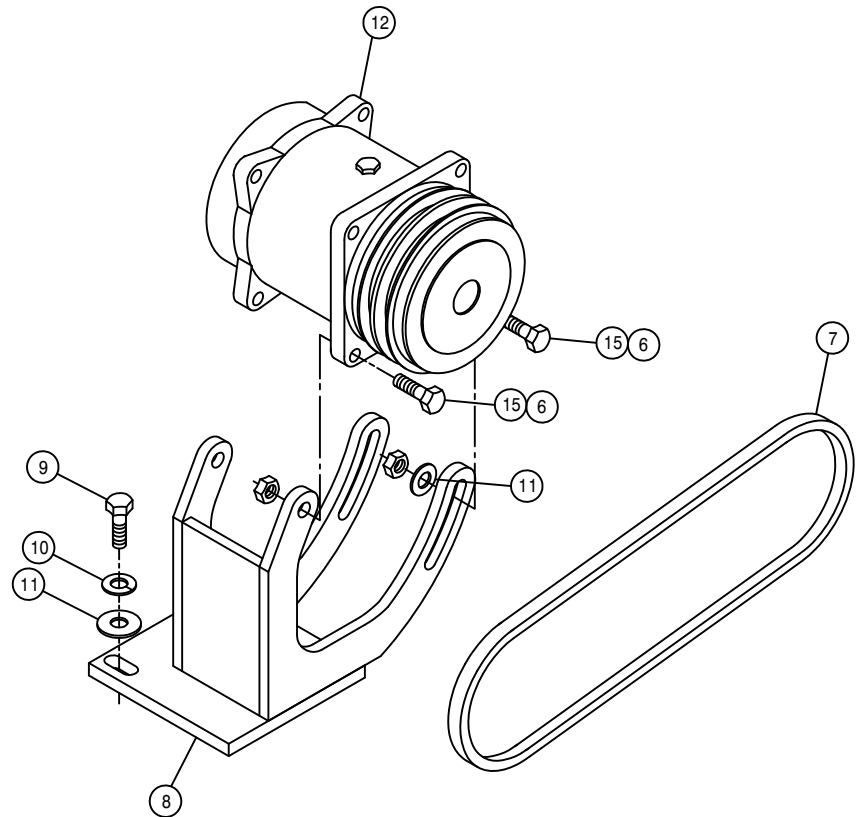
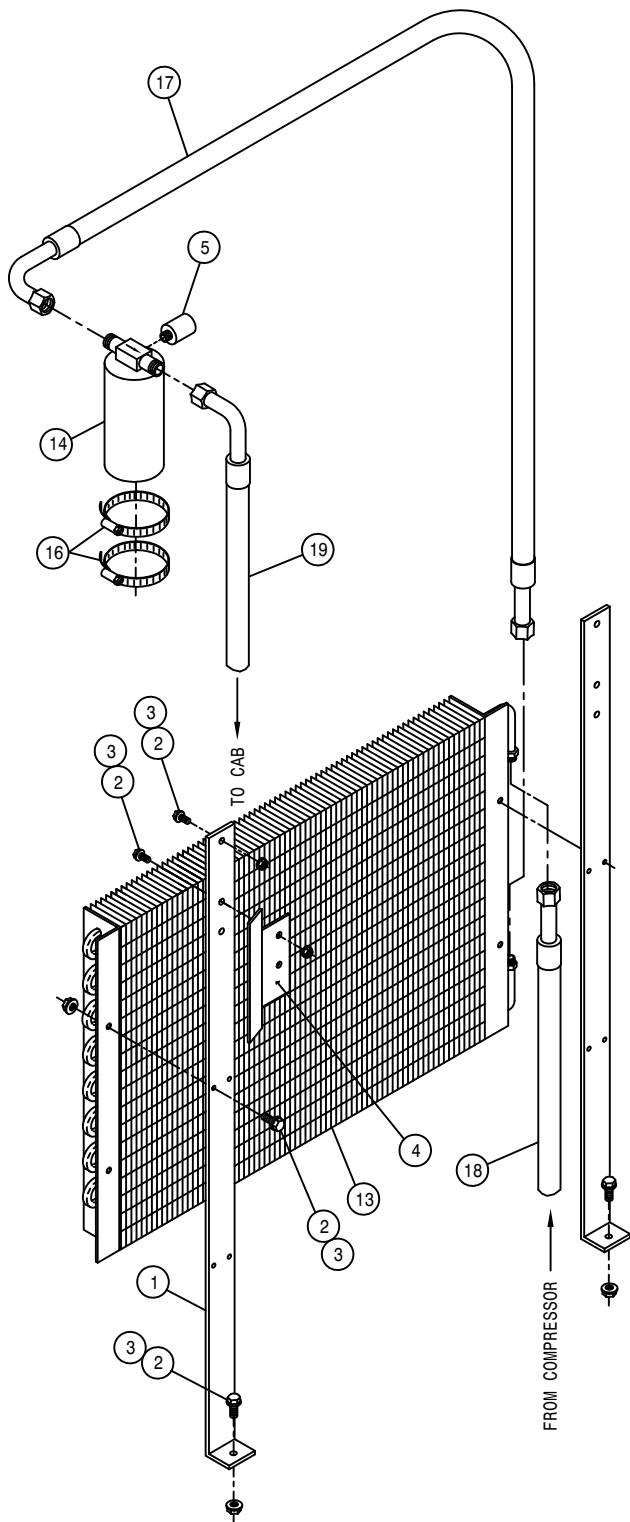

A/C COMPRESSOR PUMP ASSEMBLY

DET.	QTY	PART NO.	DESCRIPTION		
	1	2	315036	CONDENSER MTG BRKT	99
	2	10	470118	1/4UNC X 3/4 FLANGE HEX BOLT	
	3	10	470121	1/4UNC HEX FLANGE LOCK NUT	
	4	1	315038	A/C DRIER MT,204-254-284	99
	5	1	657422	A/C BINARY SWITCH	
	6	4	914004	3/8UNC HEX STOVER NUT	
	7	1	147050	9455XL BELT, GATES	
	8	1	316314	A/C COMPRESR MT WLD, 284	98
	9	3	473792	10MM-1.50 X 30MM HEX BOLT	
	10	3	473798	10MM LOCK WASHER	
	11	5	483043	3/8 REGULAR FLAT WASHER	
	12	1	657403	A/C COMPRESR,180D PORTS TM15/12	
	13	1	657423	A/C CONDENSER COIL 21-0324	
	14	1	657421	A/C RECEIVER/DRIER	
	15	4	900131	3/8UNC X 1 1/2 HEX BOLT	
	16	2	520052	HOSE CLAMP NO 52 STAINLESS	
	17	1	657429	A/C HOSE ASSY, 5/16 X 44	
	18	1	657430	A/C HOSE ASSY, 13/32 X 80	
	19	1	657431	A/C HOSE ASSY, 5/16 X 173	

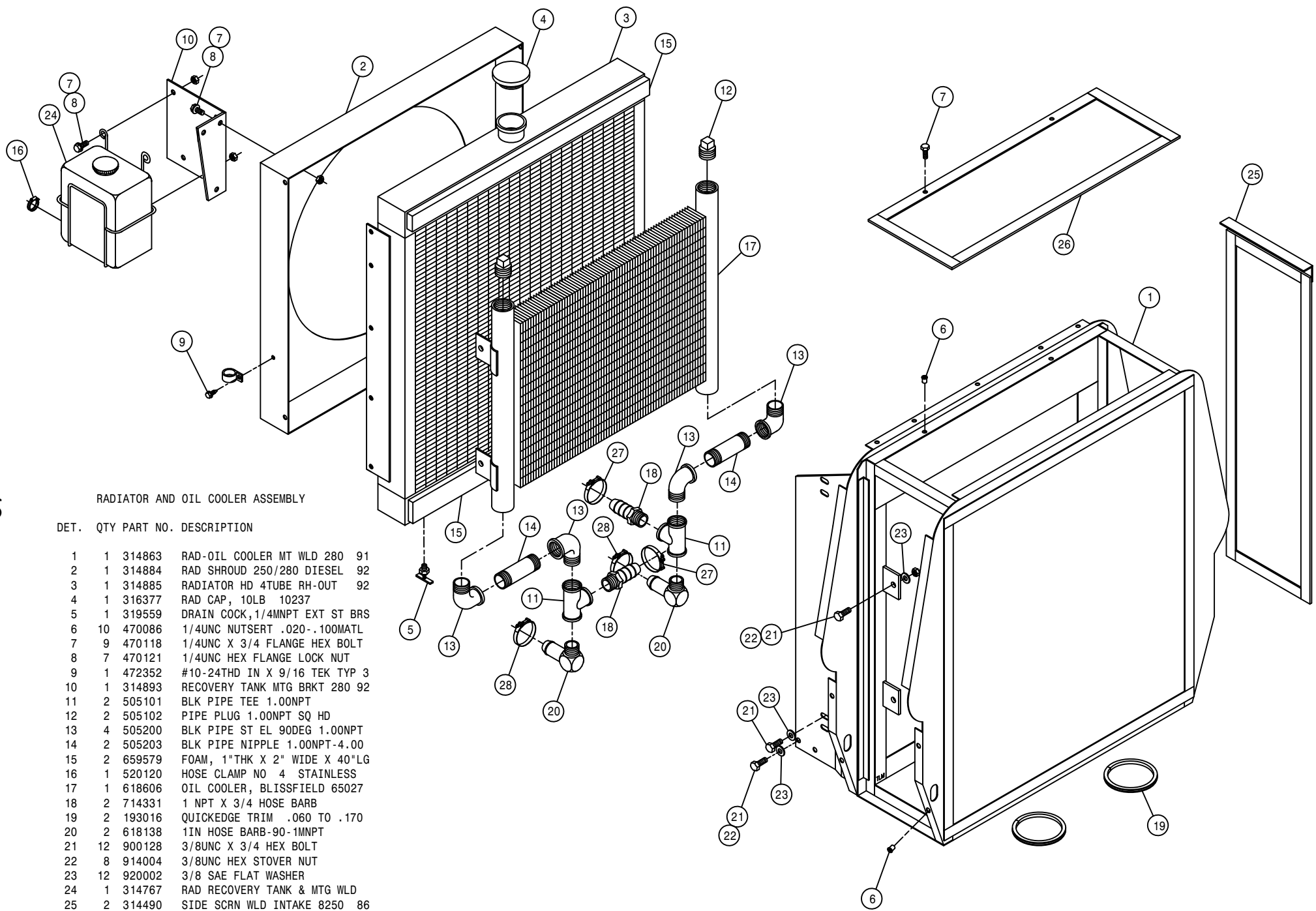

RADIATOR AND OIL COOLER ASSEMBLY

DET.	QTY	PART NO.	DESCRIPTION
1	1	314863	RAD-OIL COOLER MT WLD 280 91
2	1	314884	RAD SHROUD 250/280 DIESEL 92
3	1	314885	RADIATOR HD 4TUBE RH-OUT 92
4	1	316377	RAD CAP, 10LB 10237
5	1	319559	DRAIN COCK, 1/4MNPT EXT ST BRS
6	10	470086	1/4UNC NUTSERT .020-.100MATL
7	9	470118	1/4UNC X 3/4 FLANGE HEX BOLT
8	7	470121	1/4UNC HEX FLANGE LOCK NUT
9	1	472352	#10-24THD IN X 9/16 TEK TYP 3
10	1	314893	RECOVERY TANK MTG BRKT 280 92
11	2	505101	BLK PIPE TEE 1.00NPT
12	2	505102	PIPE PLUG 1.00NPT SQ HD
13	4	505200	BLK PIPE ST EL 90DEG 1.00NPT
14	2	505203	BLK PIPE NIPPLE 1.00NPT-4.00
15	2	659579	FOAM, 1"THK X 2" WIDE X 40"LG
16	1	520120	HOSE CLAMP NO 4 STAINLESS
17	1	618606	OIL COOLER, BLISSFIELD 65027
18	2	714331	1 NPT X 3/4 HOSE BARB
19	2	193016	QUICKEDGE TRIM .060 TO .170
20	2	618138	1IN HOSE BARB-90-1MNPT
21	12	900128	3/8UNC X 3/4 HEX BOLT
22	8	914004	3/8UNC HEX STOVER NUT
23	12	920002	3/8 SAE FLAT WASHER
24	1	314767	RAD RECOVERY TANK & MTG WLD
25	2	314490	SIDE SCR N WLD INTAKE 8250 86
26	1	314495	TOP SCR N WLD INTAKE 8250 86
27	2	520137	1.12/1.25 T-BOLT HOSE CLAMP
28	2	520138	1.38/1.56 T-BOLT HOSE CLAMP

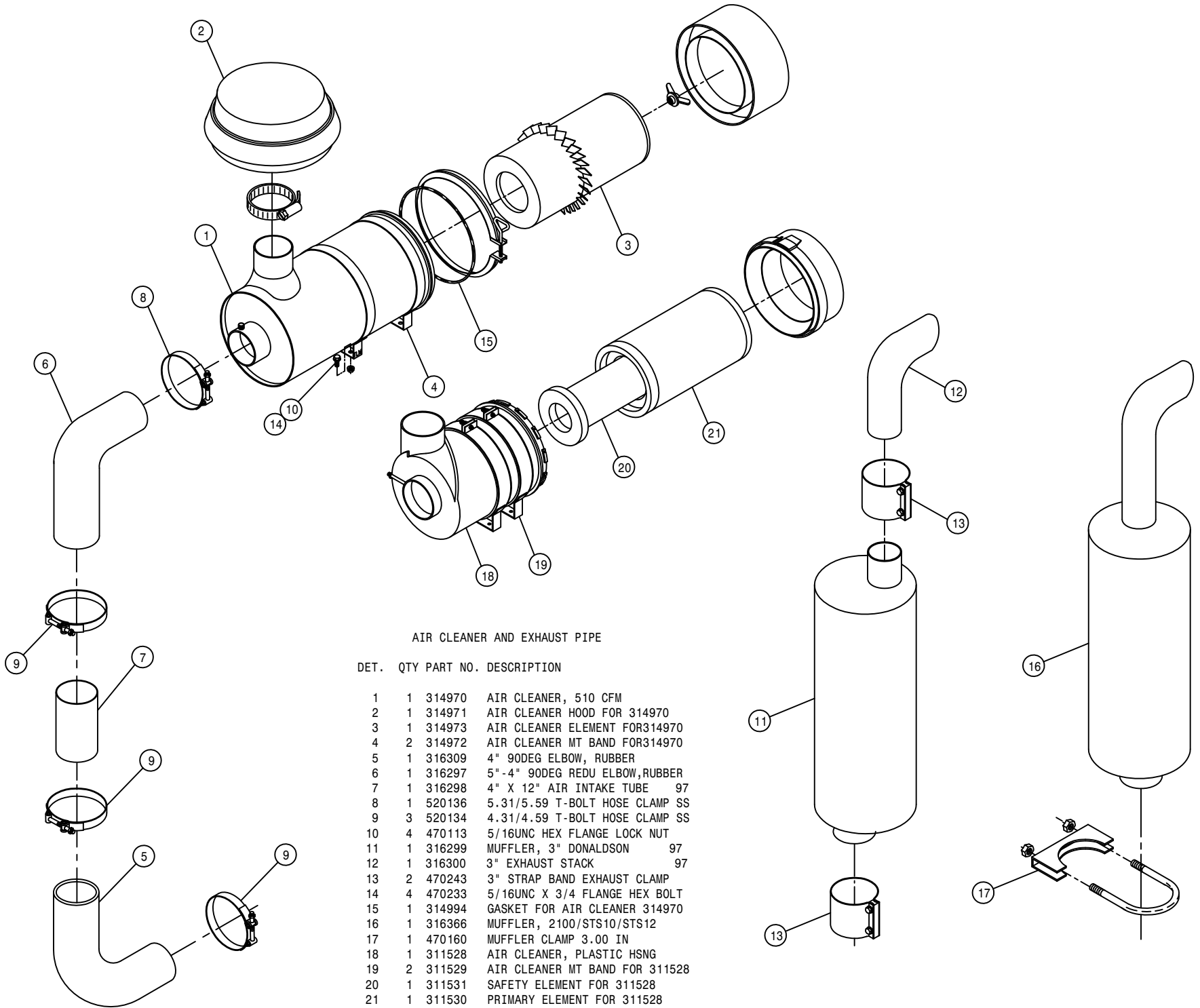

AIR CLEANER AND EXHAUST PIPE

DET.	QTY	PART NO.	DESCRIPTION
	1	314970	AIR CLEANER, 510 CFM
	1	314971	AIR CLEANER HOOD FOR 314970
	1	314973	AIR CLEANER ELEMENT FOR314970
	2	314972	AIR CLEANER MT BAND FOR314970
	1	316309	4" 90DEG ELBOW, RUBBER
	1	316297	5"-4" 90DEG REDU ELBOW,RUBBER
	1	316298	4" X 12" AIR INTAKE TUBE 97
	1	520136	5.31/5.59 T-BOLT HOSE CLAMP SS
	3	520134	4.31/4.59 T-BOLT HOSE CLAMP SS
	4	470113	5/16UNC HEX FLANGE LOCK NUT
	1	316299	MUFFLER, 3" DONALDSON 97
	1	316300	3" EXHAUST STACK 97
	2	470243	3" STRAP BAND EXHAUST CLAMP
	4	470233	5/16UNC X 3/4 FLANGE HEX BOLT
	1	314994	GASKET FOR AIR CLEANER 314970
	1	316366	MUFFLER, 2100/STS10/STS12
	1	470160	MUFFLER CLAMP 3.00 IN
	1	311528	AIR CLEANER, PLASTIC HSNG
	2	311529	AIR CLEANER MT BAND FOR 311528
	1	311531	SAFETY ELEMENT FOR 311528
	1	311530	PRIMARY ELEMENT FOR 311528

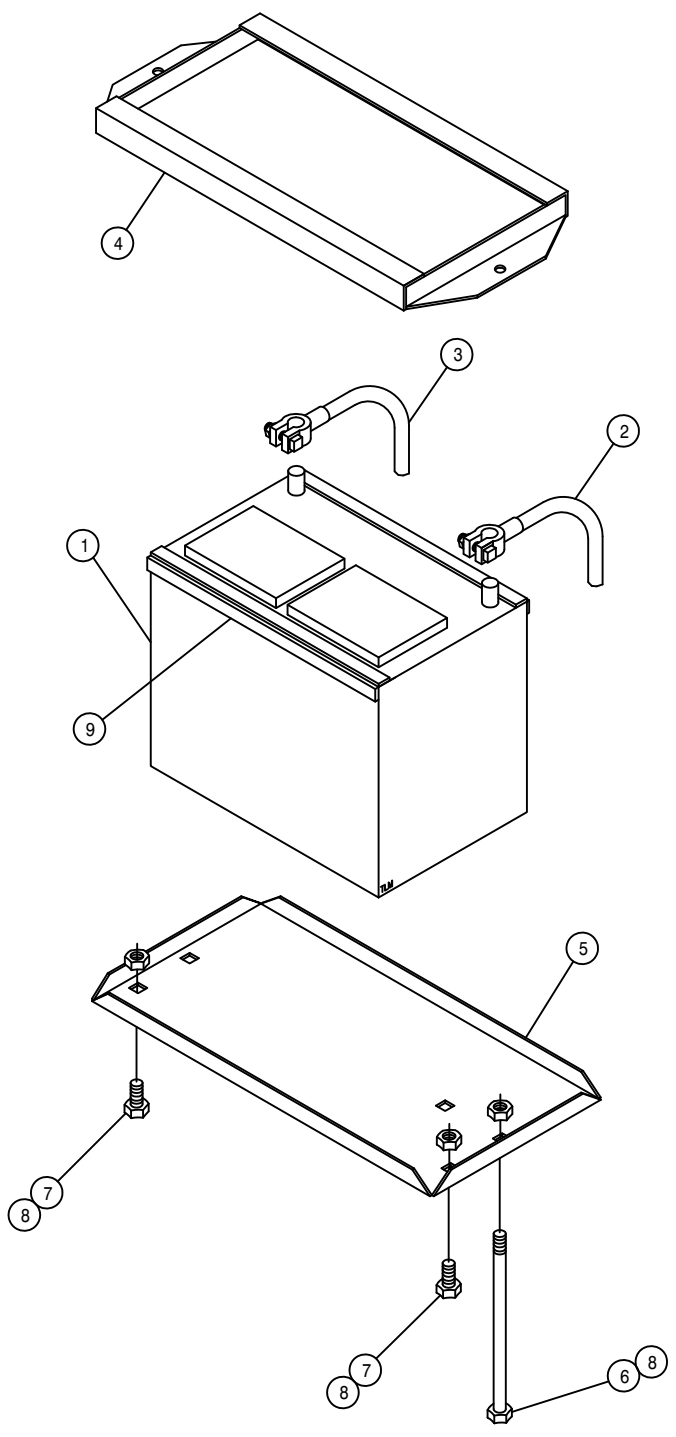

BATTERY BOX ASSEMBLY

DET.	QTY	PART NO.	DESCRIPTION
1	1	291122	BATTERY, 12V 950CCA, SAE POST
2	1	291128	BATTERY CABLE 48 IN
3	1	291530	BATTERY GROUND CABLE, 23"
4	1	341322	BATTERY HOLD DOWN WLD 1981
5	1	361149	BATTERY BOX 8300-8400 1981
6	2	901150	3/8UNC X 9" CARR BOLT
7	2	900129	3/8UNC X 1" HEX BOLT
8	4	914004	3/8UNC HEX STOVER NUT
9	4	193022	STICKERTITE 1/4 X 3/4

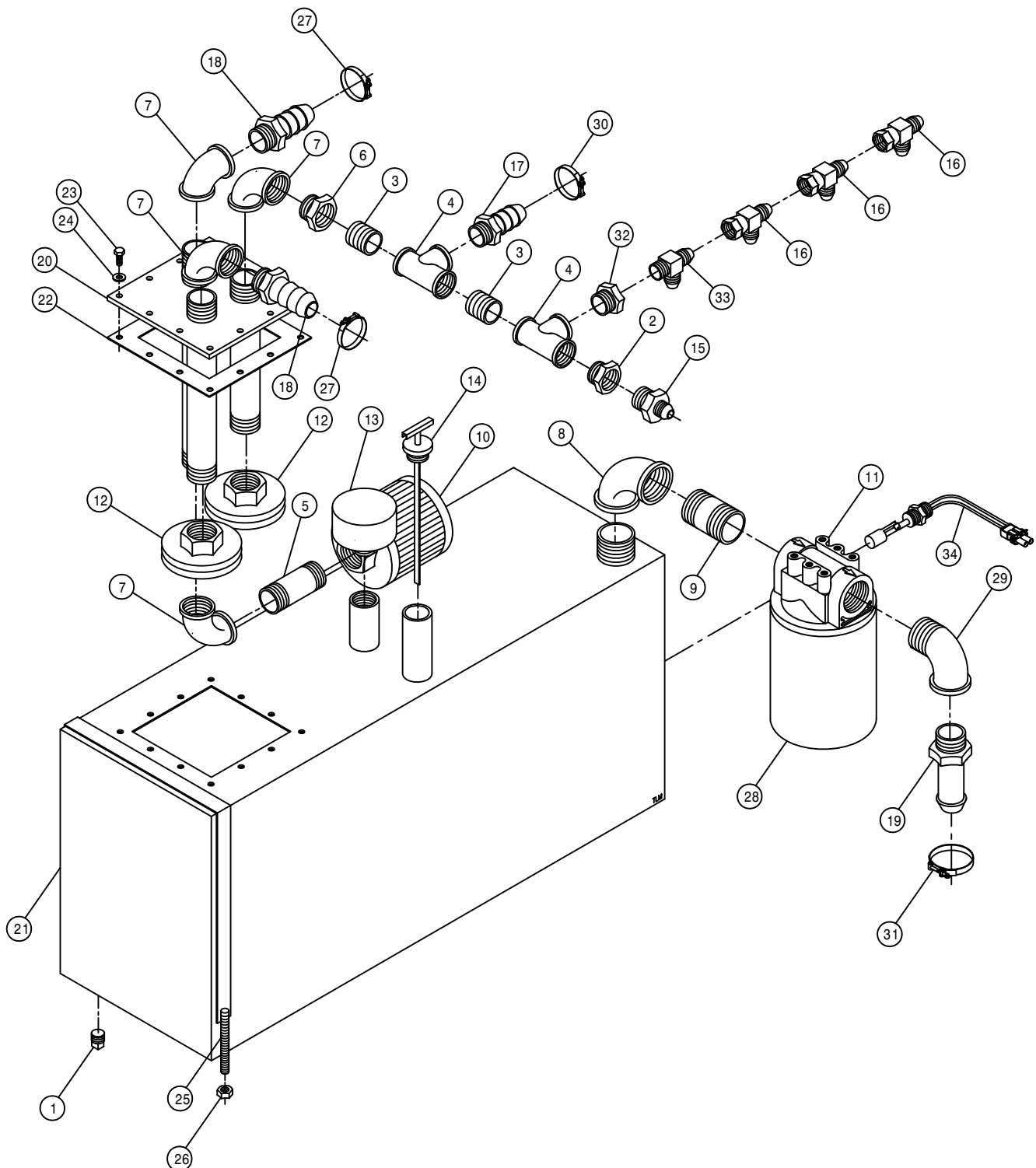

HYDRAULIC TANK ASSEMBLY

DET.	QTY	PART NO.	DESCRIPTION
1	1	470308	1/2MNPT DRAIN PLUG,AL HD,MAG
2	1	504210	RED BUSH 3/4 NPT X 1/2 NPT
3	2	504702	CLOSE NIPPLE .75NPT
4	2	504955	BLK PIPE TEE .75NPT
5	1	505203	BLK PIPE NIPPLE 1.00NPT-4.00
6	1	505213	RED BUSH 1 X 3/4 BLK MAL
7	4	505300	BLK PIPE EL 90DEG 1.00NPT
8	1	506303	BLK PIPE EL 90DEG 1.25NPT
9	1	506602	PIPE NIPPLE 1 1/4NPT-2 1/2
10	1	605600	TANK FILTER, 100 MESH,1"FNPT
11	1	605601	PARKER FILTER ASSY,10M,1.25NPT
12	2	605603	LINE SUMP DIFFUSER
13	1	611052	FILLER BREATHER 3/4NPT
14	1	614453	DIPSTICK, 8IN
15	1	618018	9/16MJIC-1/2MNPT ADPTR
16	3	618486	9/16FJIC SW RUN TEE-9/16MJIC
17	1	713220	HOSE BARB 3/4 NPT X 3/4
18	2	714560	1NPT X 1 HOSE BARB
19	1	715660	HOSE BARB 1 1/4NPT X 1 1/4
20	1	760090	RECEIVER PLT WLD 8240
21	1	760264	HYD TANK WLD,204/254/284 2002
22	1	763039	HYD MTR MTG PLT GSKT
23	12	900064	5/16UNC X 3/4 HEX BOLT
24	12	920001	5/16 SAE FLAT WASHER
25	2	341360	OIL TANK STRAP WLD 8240 1982
26	4	914004	3/8UNC HEX STOVER NUT
27	2	520138	1.38/1.56 T-BOLT HOSE CLAMP
28	1	605602	PARKER FILTER ELEMENT,10MICRON
29	1	506410	BLK PIPE ST EL 90DEG 1.25NPT
30	1	520137	1.12/1.25 T-BOLT HOSE CLAMP
31	1	520132	1.62/1.87 T-BOLT HOSE CLAMP SS
32	1	504001	RED BUSH 3/4 X 1/4 BLK MAL
33	1	618520	1/4MNPT RUN TEE-9/16MJIC
34	1	470350	LIQUID LEVEL SWITCH ASSY,1/2NP



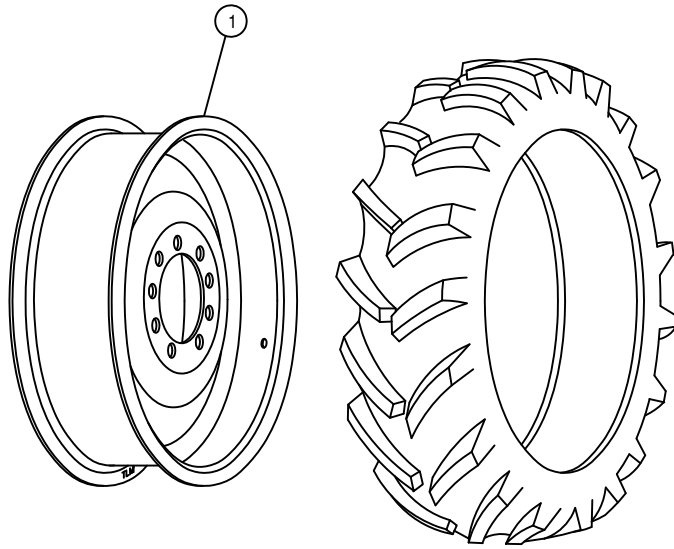

13.6-28 RADIAL TIRE

TIRE AND RIM ASSEMBLY

DET. QTY PART NO. DESCRIPTION

1	1	821045	RIM WLD, W12 X 28	284	98
---	---	--------	-------------------	-----	----

RIGHT FRONT LEG ASSEMBLY

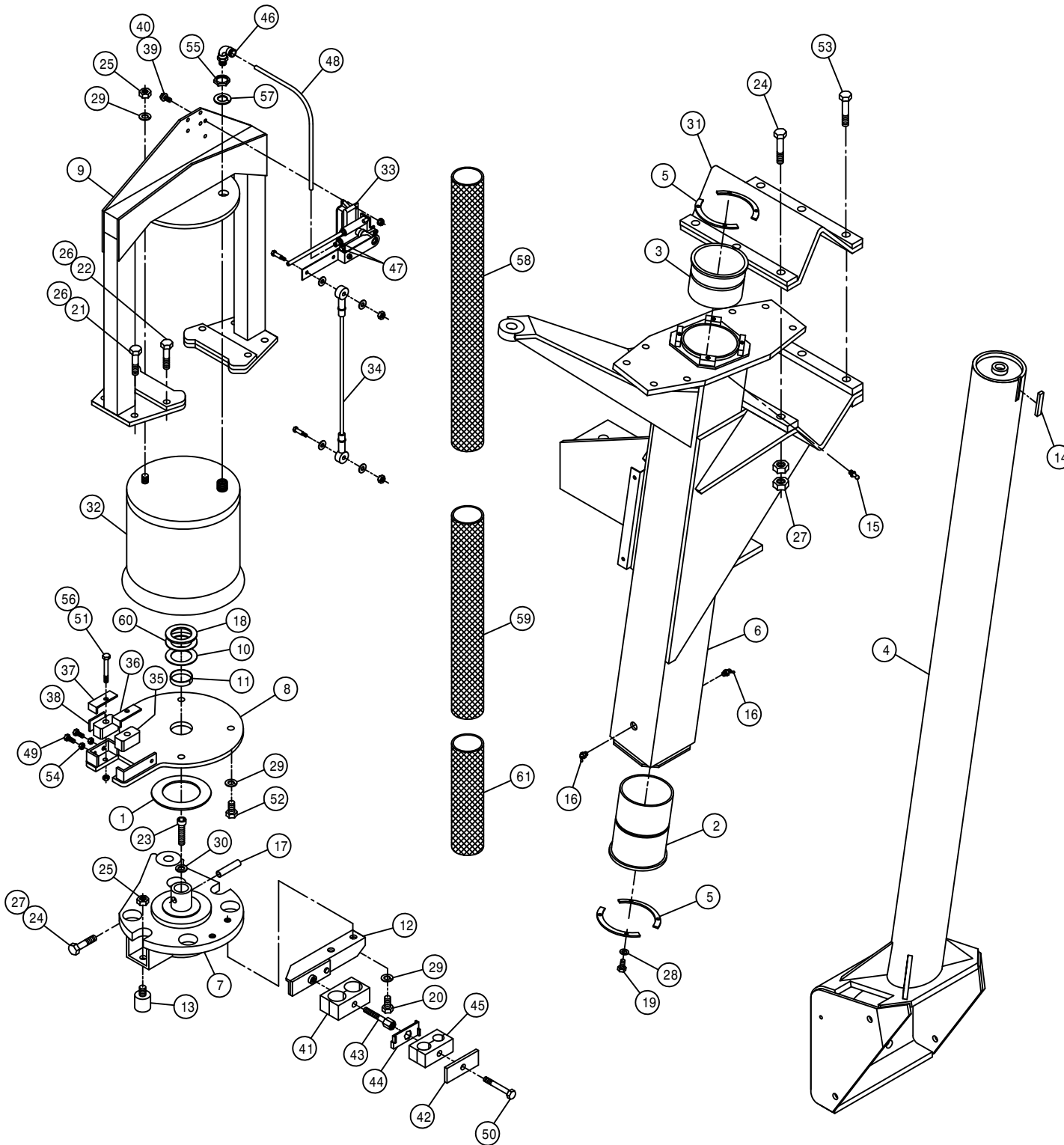

DET.	QTY	PART NO.	DESCRIPTION
1	1	127505	THRUST BEARING, FIBERGLIDE
2	1	358564	FRT LEG LWR NYL SLEEVE 280 89
3	1	358565	FRT LEG UPR NYL SLEEVE 280 89
4	1	359175	RF/LR INNER LEG WLD, 284XP 02
5	4	358927	LWR BRG KPR, LEG 98
6	1	358954	RH FRT OUTER LEG WLD, 2100 99
7	1	358971	STEERING ARM WLD,RF/LR 2100 99
8	1	358980	AIR BAG MT WLD, RF/LR 2100 99
9	1	358985	AIR BAG ARCH WLD,RF/LR 2100 99
10	1	358994	LEG WASHER, NYLON 2100 99
11	1	358995	NYLON BEARING,LWR AB MT2100 99
12	1	358996	RH UPPER HOSE MT WELD, 2100 99
13	2	470259	URETHANE BUMPER,1.25D X 1.25L
14	1	470265	KEY, .250 X .375 X 1.88 LG
15	1	471005	1/4 28 X 1/2 GREASE ZERK
16	2	471023	GREASE ZERK 1/4-28 X 45
17	1	473906	SPIRAL PIN, 1/2 X 2 1/2 LG
18	1	483061	1.65 ID X 2.50 OD X .188T WASH
19	8	900064	5/16UNC X 3/4 HEX BOLT
20	2	900263	1/2UNC X 1" HEX BOLT
21	4	900265	1/2UNC X 1 1/2 HEX BOLT
22	4	900267	1/2UNC X 2" HEX BOLT
23	1	900390	5/8UNC X 2 1/2 SOCKET CAP SCR
24	4	900836	5/8UNF X 3 1/4 HEX BOLT GR8
25	3	910008	1/2UNC HEX NUT
26	8	914008	1/2UNC HEX STOVER NUT
27	14	914811	5/8UNF HEX NUT GR8
28	8	920501	5/16 LOCK WASHER
29	7	920504	1/2 LOCK WASHER
30	1	920505	5/8 LOCK WASHER
31	1	358759	LEG MT V-PLT WLD, 284T 94
32	1	358831	AIRIDE SPRING 98
33	1	358832	AIRIDE SPRING CTRL VALVE 98
34	1	358839	AIRRIIDE CTRL LINK KIT, 2100 99
35	2	358990	NYLON GUIDE, 2100 LEG 99
36	1	358991	INNER KEEPER,NYL GUIDE,2100 99
37	1	358992	OUTER KEEPER,NYL GUIDE,2100 99
38	1	358993	NYLON GUIDE BACK PLATE,2100 99
39	2	470118	1/4UNC X 3/4 FLANGE HEX BOLT
40	2	470121	1/4UNC HEX FLANGE LOCK NUT
41	1	470347	HOSE CLAMP BODY,1.16-1.16
42	1	470276	CLAMP COVER PLATE,SNGL, 2.55LG
43	1	470280	STACK BOLT, 5/16UNC X 1 3/4
44	1	470281	STACK BOLT SAFETY LOCK PLATE
45	1	470270	HOSE CLAMP BODY,.530-.680
46	1	711040	1/4MNPT-90-1/4 NYL TUBE LBO
47	2	711036	1/8MNPT-1/4 NYL TUBE FTG
48	1	601413	HOSE, 1/4 X 8 AIR
49	2	900065	5/16UNC X 1" HEX BOLT
50	1	900068	5/16UNC X 1 3/4 HEX BOLT
51	2	900069	5/16UNC X 2" HEX BOLT
52	4	900264	1/2UNC X 1 1/4 HEX BOLT
53	3	900837	5/8UNF X 3 1/2 HEX BOLT GR8
54	2	910002	5/16UNC HEX NUT
55	1	910013	3/4UNF HEX NUT
56	2	914002	5/16UNC HEX STOVER NUT
57	1	920506	3/4 LOCK WASHER
58	1	342637	NYL HOSE SLEEVE,2.96ID X 54.00
59	1	342335	NYL HOSE SLEEVE,2.64ID X 36.00
60	1	483063	1.65 ID X 2.50 OD X .074T WASH
61	1	342654	NYL HOSE SLEEVE,3.66ID X 24.00

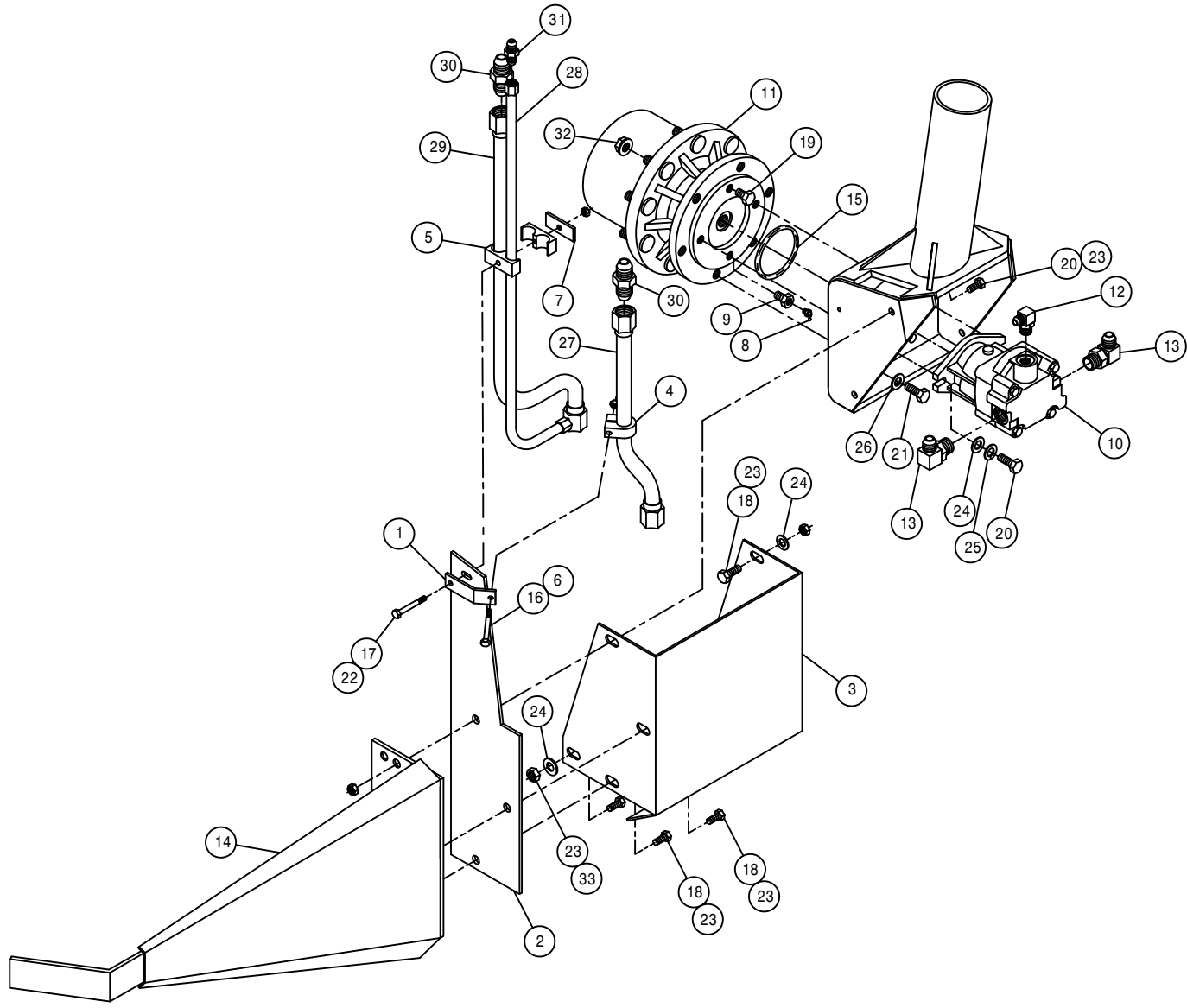

RIGHT FRONT LEG ASSEMBLY

DET.	QTY	PART NO.	DESCRIPTION
1	1	359124	FRT LEG HYD TUBE BRKT,284XP 01
2	1	359014	FRT HYD TUBE MTG PLT,2100 00
3	1	359185	WHL MTR SHLD, XP/2100 2002
4	1	470341	TUBE CLAMP BODY, .500
5	1	470340	TUBE CLAMP BODY, .500-.750
6	1	914000	1/4UNC HEX STOVER NUT
7	1	470278	CLAMP WELD PLATE, SNGL, 2.75LG
8	1	471023	GREASE ZERK 1/4-28 X 45
9	1	610556	1/2UNC X 1/2 ZERK BOLT T-HUB
10	1	610571	SUND M35-3002 WHL MTR
11	1	610683	TORQ HUB, 15:1 B-MT MW3BA
12	1	618183	3/4MJIC-90-7/8MOR LBO
13	2	618248	1 1/16MJIC-90-1 1/16MOR LBO
14	1	662256	STALK GUIDE WLD, 2100 2000
15	1	870045	O-RING 4 1/8 OD X 4 ID
16	1	900006	1/4UNC X 1 3/4 HEX BOLT
17	1	900070	5/16UNC X 2 1/2 BOLT
18	3	900264	1/2UNC X 1 1/4 HEX BOLT
19	1	900260	1/2UNC X 1/2 H BOLT GR2 UNPLT
20	3	900265	1/2UNC X 1 1/2 HEX BOLT
21	6	900333	5/8UNC X 1 1/2 HEX BOLT
22	1	914002	5/16UNC HEX STOVER NUT
23	6	914008	1/2UNC HEX STOVER NUT
24	5	920004	1/2 SAE FLAT WASHER
25	2	920504	1/2 LOCK WASHER
26	6	920505	5/8 LOCK WASHER
27	1	615792	FRT LEG INNER HYD TUBE ASSY XP
28	1	615793	FRT LEG CNTR HYD TUBE ASSY XP
29	1	615794	RH FRT LEG OTR HYD TUBE ASSY
30	2	618177	1 1/16MJIC UNION
31	1	618314	3/4MJIC UNION
32	9	470140	5/8UNF HEX SMTH FLANGE NUT PLT
33	2	900263	1/2UNC X 1" HEX BOLT

LEFT FRONT LEG ASSEMBLY

DET. QTY PART NO. DESCRIPTION

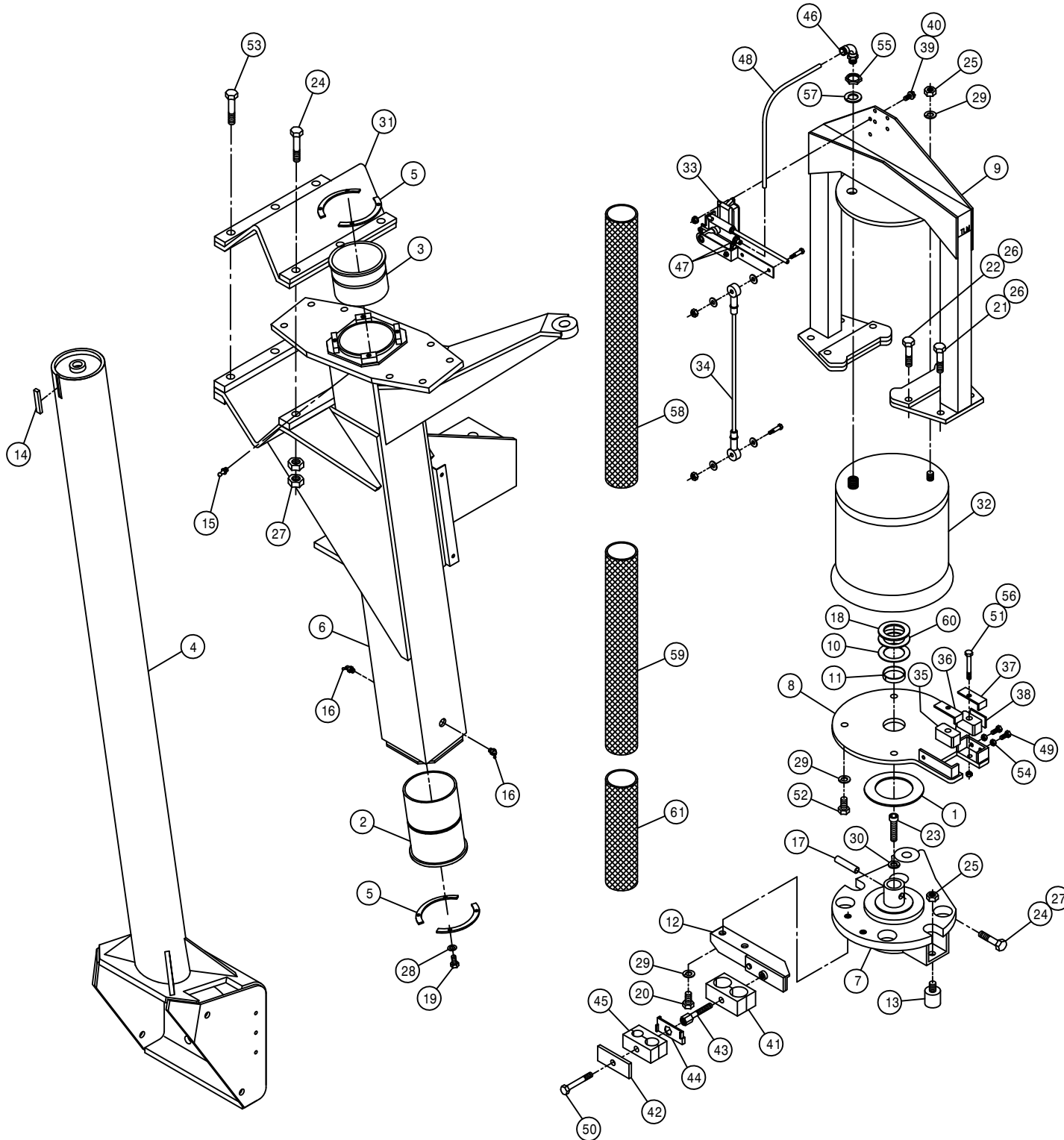

1	1	127505	THRUST BEARING, FIBERGLIDE
2	1	358564	FRT LEG LWR NYL SLEEVE 280 89
3	1	358565	FRT LEG UPR NYL SLEEVE 280 89
4	1	359176	LF/RR INNER LEG WLD, 284XP 02
5	4	358927	LWR BRG KPR, LEG 98
6	1	358955	LH FRT OUTER LEG WLD, 2100 99
7	1	358972	STEERING ARM WLD, LF/RR 2100 99
8	1	358981	AIR BAG MT WLD, LF/RR 2100 99
9	1	358986	AIR BAG ARCH WLD, LF/RR 2100 99
10	1	358994	LEG WASHER, NYLON 2100 99
11	1	358995	NYLON BEARING, LWR AB MT2100 99
12	1	358997	LH UPPER HOSE MT WELD, 2100 99
13	2	470259	URETHANE BUMPER, 1.25D X 1.25L
14	1	470265	KEY, .250 X .375 X 1.88 LG
15	1	471005	1/4 28 X 1/2 GREASE ZERK
16	2	471023	GREASE ZERK 1/4-28 X 45
17	1	473906	SPIRAL PIN, 1/2 X 2 1/2 LG
18	1	483061	1.65 ID X 2.50 OD X .188T WASH
19	8	900064	5/16UNC X 3/4 HEX BOLT
20	2	900263	1/2UNC X 1" HEX BOLT
21	4	900265	1/2UNC X 1 1/2 HEX BOLT
22	4	900267	1/2UNC X 2" HEX BOLT
23	1	900390	5/8UNC X 2 1/2 SOCKET CAP SCR
24	4	900836	5/8UNF X 3 1/4 HEX BOLT GR8
25	3	910008	1/2UNC HEX NUT
26	8	914008	1/2UNC HEX STOVER NUT
27	14	914811	5/8UNF HEX NUT GR8
28	8	920501	5/16 LOCK WASHER
29	7	920504	1/2 LOCK WASHER
30	1	920505	5/8 LOCK WASHER
31	1	358759	LEG MT V-PLT WLD, 284T 94
32	1	358831	AIRIDE SPRING 98
33	1	358832	AIRIDE SPRING CTRL VALVE 98
34	1	358839	AIRIDE CTRL LINK KIT, 2100 99
35	2	358990	NYLON GUIDE, 2100 LEG 99
36	1	358991	INNER KEEPER, NYL GUIDE, 2100 99
37	1	358992	OUTER KEEPER, NYL GUIDE, 2100 99
38	1	358993	NYLON GUIDE BACK PLATE, 2100 99
39	2	470118	1/4UNC X 3/4 FLANGE HEX BOLT
40	2	470121	1/4UNC HEX FLANGE LOCK NUT
41	1	470347	HOSE CLAMP BODY, 1.16-1.16
42	1	470276	CLAMP COVER PLATE, SNGL, 2.55LG
43	1	470280	STACK BOLT, 5/16UNC X 1 3/4
44	1	470281	STACK BOLT SAFETY LOCK PLATE
45	1	470270	HOSE CLAMP BODY, .530-.680
46	1	711040	1/4MNPT-90-1/4 NYL TUBE LBO
47	2	711036	1/8MNPT-1/4 NYL TUBE FTG
48	1	601413	HOSE, 1/4 X 8 AIR
49	2	900065	5/16UNC X 1" HEX BOLT
50	1	900068	5/16UNC X 1 3/4 HEX BOLT
51	2	900069	5/16UNC X 2" HEX BOLT
52	4	900264	1/2UNC X 1 1/4 HEX BOLT
53	3	900837	5/8UNF X 3 1/2 HEX BOLT GR8
54	2	910002	5/16UNC HEX NUT
55	1	910013	3/4UNF HEX NUT
56	2	914002	5/16UNC HEX STOVER NUT
57	1	920506	3/4 LOCK WASHER
58	1	342637	NYL HOSE SLEEVE, 2.96ID X 54.00
59	1	342335	NYL HOSE SLEEVE, 2.64ID X 36.00
60	1	483063	1.65 ID X 2.50 OD X .074T WASH
61	1	342654	NYL HOSE SLEEVE, 3.66ID X 24.00

LEFT FRONT LEG ASSEMBLY

DET.	QTY	PART NO.	DESCRIPTION
1	1	359124	FRT LEG HYD TUBE BRKT,284XP 01
2	1	359014	FRT HYD TUBE MTG PLT,2100 00
3	1	359185	WHL MTR SHLD, XP/2100 2002
4	1	470341	TUBE CLAMP BODY, .500
5	1	470340	TUBE CLAMP BODY, .500-.750
6	1	914000	1/4UNC HEX STOVER NUT
7	1	470278	CLAMP WELD PLATE, SNGL, 2.75LG
8	1	471023	GREASE ZERK 1/4-28 X 45
9	1	610556	1/2UNC X 1/2 ZERK BOLT T-HUB
10	1	610571	SUND M35-3002 WHL MTR
11	1	610683	TORQ HUB, 15:1 B-MT MW3BA
12	1	618183	3/4MJIC-90-7/8MOR LBO
13	2	618248	1 1/16MJIC-90-1 1/16MOR LBO
14	1	662256	STALK GUIDE WLD, 2100 2000
15	1	870045	O-RING 4 1/8 OD X 4 ID
16	1	900006	1/4UNC X 1 3/4 HEX BOLT
17	1	900070	5/16UNC X 2 1/2 BOLT
18	3	900264	1/2UNC X 1 1/4 HEX BOLT
19	1	900260	1/2UNC X 1/2 H BOLT GR2 UNPLT
20	3	900265	1/2UNC X 1 1/2 HEX BOLT
21	6	900333	5/8UNC X 1 1/2 HEX BOLT
22	1	914002	5/16UNC HEX STOVER NUT
23	6	914008	1/2UNC HEX STOVER NUT
24	5	920004	1/2 SAE FLAT WASHER
25	2	920504	1/2 LOCK WASHER
26	6	920505	5/8 LOCK WASHER
27	1	615792	FRT LEG INNER HYD TUBE ASSY XP
28	1	615793	FRT LEG CNTR HYD TUBE ASSY XP
29	1	615795	LH FRT LEG OTR HYD TUBE ASSY
30	2	618177	1 1/16MJIC UNION
31	1	618314	3/4MJIC UNION
32	9	470140	5/8UNF HEX SMTH FLANGE NUT PLT
33	2	900263	1/2UNC X 1" HEX BOLT

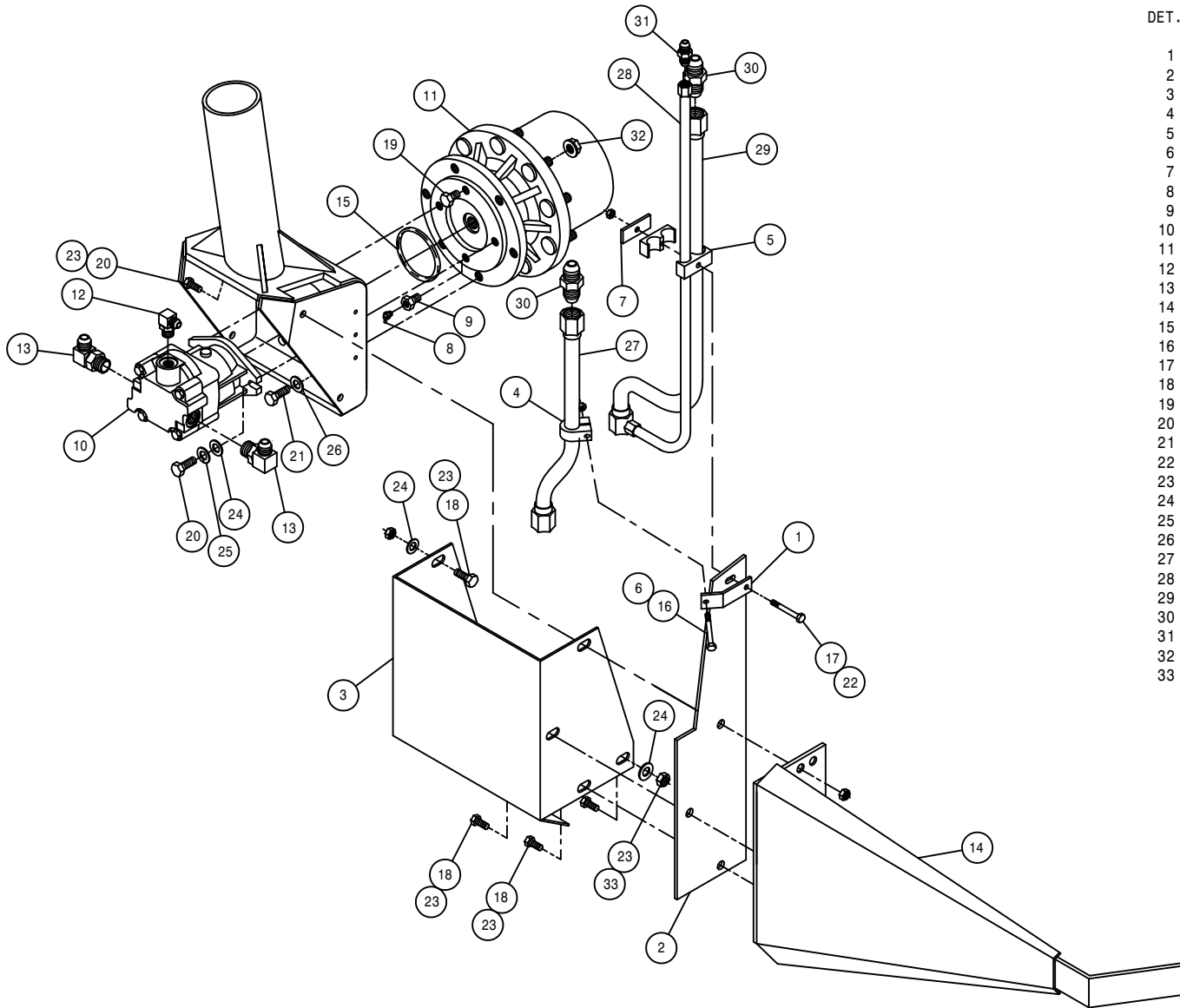

RIGHT REAR LEG ASSEMBLY

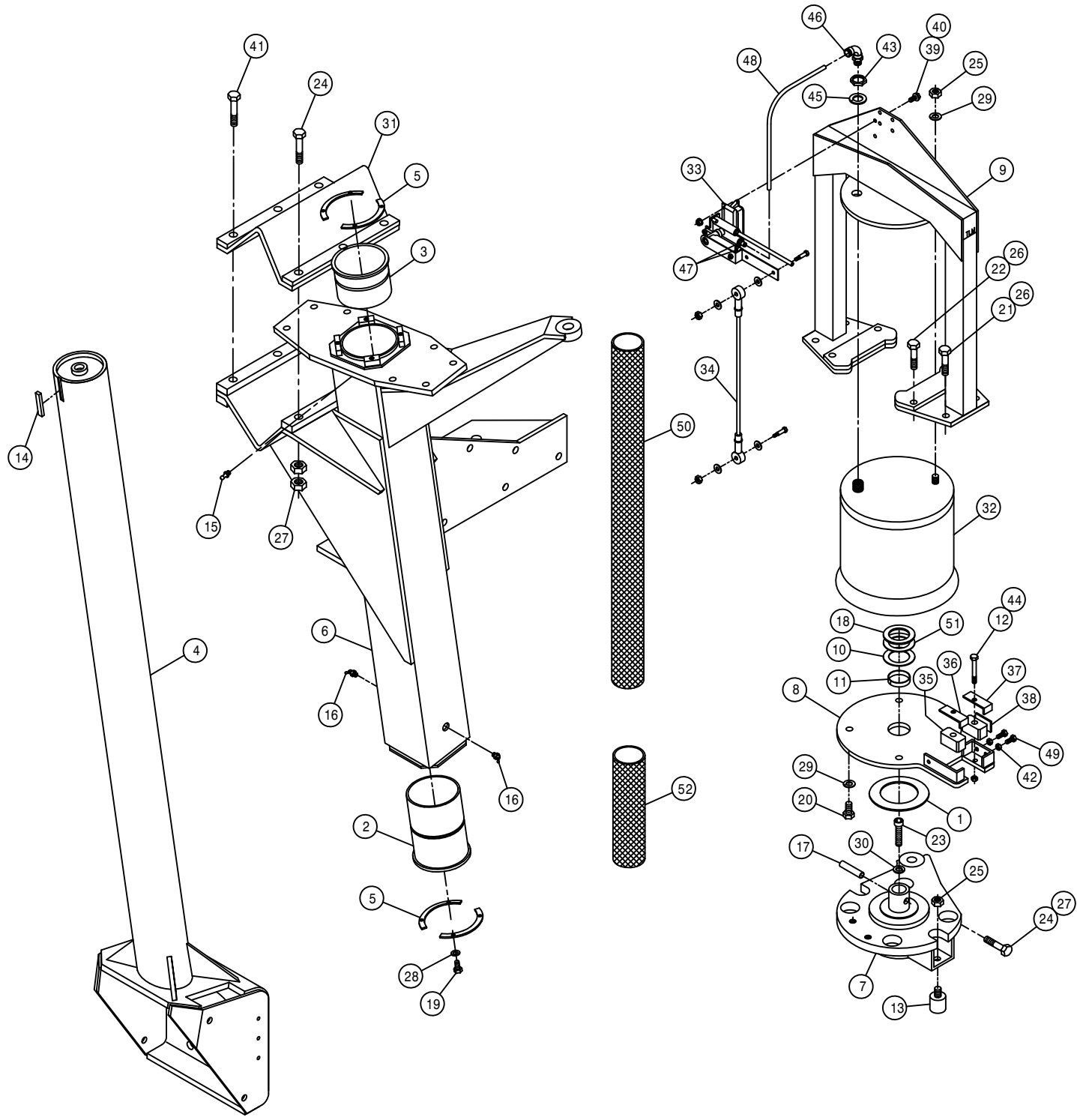

DET.	QTY	PART NO.	DESCRIPTION
1	1	483062	3.00 ID X 4.62 OD X .125T WASH
2	1	358564	FRT LEG LWR NYL SLEEVE 280 89
3	1	358565	FRT LEG UPR NYL SLEEVE 280 89
4	1	359176	LF/RR INNER LEG WLD, 284XP 02
5	4	358927	LWR BRG KPR, LEG 98
6	1	358956	RH REAR OUTER LEG WLD,2100 99
7	1	358972	STEERING ARM WLD,LF/RR 2100 99
8	1	358981	AIR BAG MT WLD, LF/RR 2100 99
9	1	358986	AIR BAG ARCH WLD,LF/RR 2100 99
10	1	358994	LEG WASHER, NYLON 2100 99
11	1	358995	NYLON BEARING,LWR AB MT2100 99
12	2	900069	5/16UNC X 2" HEX BOLT
13	2	470259	URETHANE BUMPER,1.25D X 1.25L
14	1	470265	KEY, .250 X .375 X 1.88 LG
15	1	471005	1/4 28 X 1/2 GREASE ZERK
16	2	471023	GREASE ZERK 1/4-28 X 45
17	1	473906	SPIRAL PIN, 1/2 X 2 1/2 LG
18	1	483061	1.65 ID X 2.50 OD X .188T WASH
19	8	900064	5/16UNC X 3/4 HEX BOLT
20	4	900264	1/2UNC X 1 1/4 HEX BOLT
21	4	900265	1/2UNC X 1 1/2 HEX BOLT
22	4	900267	1/2UNC X 2" HEX BOLT
23	1	900390	5/8UNC X 2 1/2 SOCKET CAP SCR
24	4	900836	5/8UNF X 3 1/4 HEX BOLT GR8
25	3	910008	1/2UNC HEX NUT
26	8	914008	1/2UNC HEX STOVER NUT
27	14	914811	5/8UNF HEX NUT GR8
28	8	920501	5/16 LOCK WASHER
29	5	920504	1/2 LOCK WASHER
30	1	920505	5/8 LOCK WASHER
31	1	358759	LEG MT V-PLT WLD, 284T 94
32	1	358831	AIRIDE SPRING 98
33	1	358832	AIRIDE SPRING CTRL VALVE 98
34	1	358839	AIRIDE CTRL LINK KIT, 2100 99
35	2	358990	NYLON GUIDE, 2100 LEG 99
36	1	358991	INNER KEEPER,NYL GUIDE,2100 99
37	1	358992	OUTER KEEPER,NYL GUIDE,2100 99
38	1	358993	NYLON GUIDE BACK PLATE,2100 99
39	2	470118	1/4UNC X 3/4 FLANGE HEX BOLT
40	2	470121	1/4UNC HEX FLANGE LOCK NUT
41	3	900837	5/8UNF X 3 1/2 HEX BOLT GR8
42	2	910002	5/16UNC HEX NUT
43	1	910013	3/4UNF HEX NUT
44	2	914002	5/16UNC HEX STOVER NUT
45	1	920506	3/4 LOCK WASHER
46	1	711040	1/4MNPT-90-1/4 NYL TUBE LBO
47	2	711036	1/8MNPT-1/4 NYL TUBE FTG
48	1	601413	HOSE, 1/4 X 8 AIR
49	2	900065	5/16UNC X 1" HEX BOLT
50	1	342828	NYL HOSE SLEEVE,3.34ID X 65.00
51	1	483063	1.65 ID X 2.50 OD X .074T WASH
52	1	342654	NYL HOSE SLEEVE,3.66ID X 24.00

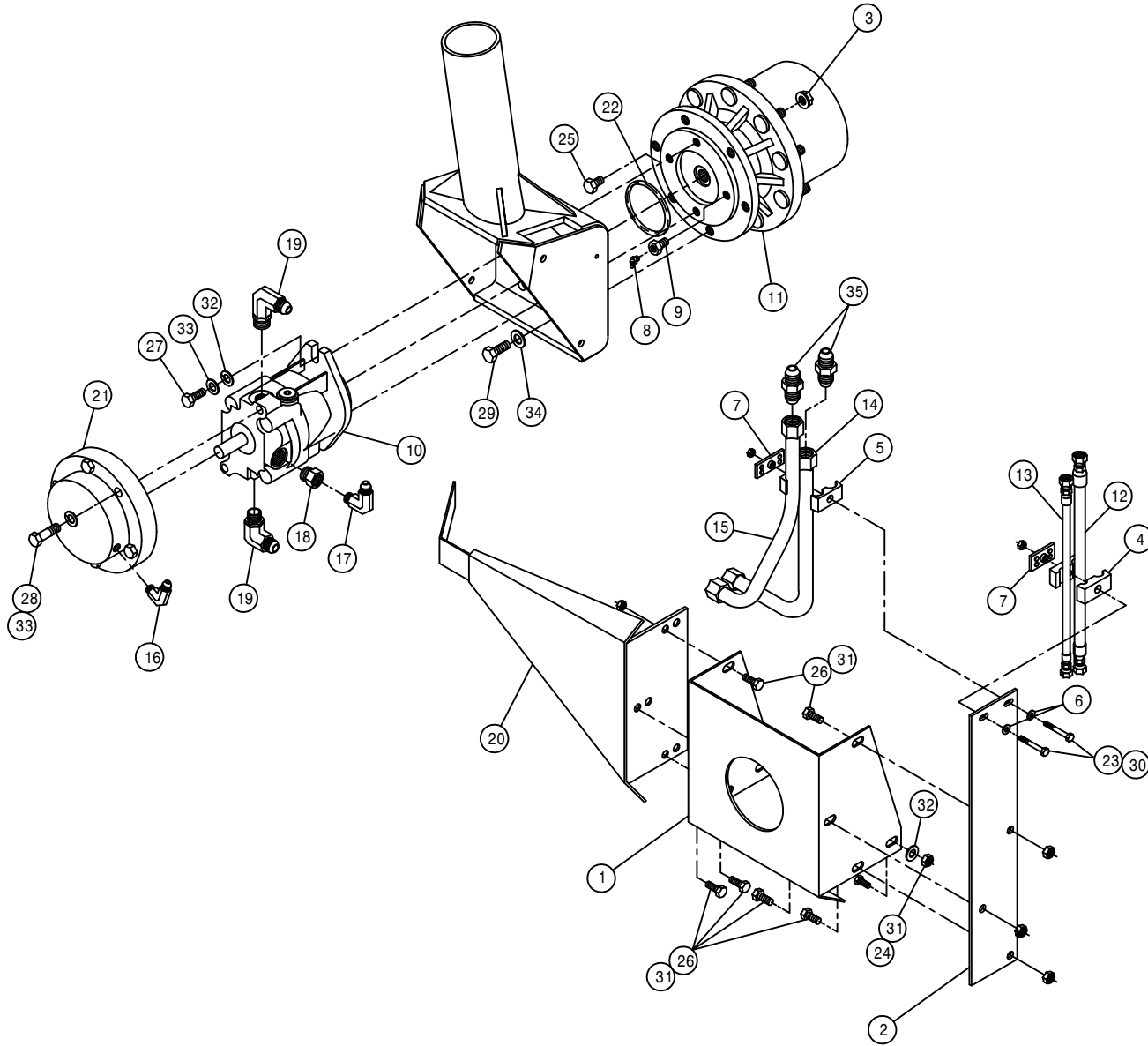

RIGHT REAR LEG ASSEMBLY

DET.	QTY	PART NO.	DESCRIPTION
1	1	359186	REAR WHL MTR SHLD, 284XP 2002
2	1	359137	REAR HYD TUBE MTG PLT 284XP
3	9	470140	5/8UNF HEX SMTH FLANGE NUT PLT
4	1	470270	HOSE CLAMP BODY, .530-.680
5	1	470275	TUBE CLAMP BODY, 1.000-1.000
6	2	920001	5/16 SAE FLAT WASHER
7	2	470278	CLAMP WELD PLATE, SNGL, 2.75LG
8	1	471023	GREASE ZERK 1/4-28 X 45
9	1	610556	1/2UNC X 1/2 ZERK BOLT T-HUB
10	1	610557	SUND M35-3102 WHL MTR W/SHFT
11	1	610692	TORQ HUB, 30:1 B-MT MW3BA
12	1	614639	04C1T-06FJX-06FJX-126 H/A
13	1	615449	06C1T-06FJX-06FJX-126 H/A
14	1	615796	REAR LEG HYD TUBE ASSY XP
15	1	615797	RH REAR LEG HYD TUBE ASSY XP
16	1	618114	9/16MJIC-90-7/16MOR LBO
17	1	618119	9/16MJIC-90-9/16MOR LBO
18	1	618172	7/8MOR-9/16FOR ADPTR
19	2	618576	1 5/16MJIC-90-1 1/16MOR LBO
20	1	662256	STALK GUIDE WLD, 2100 2000
21	1	828092	MICO HYD BRAKE
22	1	870045	O-RING 4 1/8 OD X 4 ID
23	2	900086	5/16UNC X 2 1/4 HEX BOLT
24	2	900263	1/2UNC X 1" HEX BOLT
25	1	900260	1/2UNC X 1/2 H BOLT GR2 UNPLT
26	6	900264	1/2UNC X 1 1/4 HEX BOLT
27	2	900265	1/2UNC X 1 1/2 HEX BOLT
28	2	900268	1/2UNC X 2 1/2 HEX BOLT
29	6	900333	5/8UNC X 1 1/2 HEX BOLT
30	2	914002	5/16UNC HEX STOVER NUT
31	8	914008	1/2UNC HEX STOVER NUT
32	4	920004	1/2 SAE FLAT WASHER
33	4	920504	1/2 LOCK WASHER
34	6	920505	5/8 LOCK WASHER
35	2	618577	1 5/16MJIC UNION

LEFT REAR LEG ASSEMBLY

DET. QTY PART NO. DESCRIPTION

DET.	QTY	PART NO.	DESCRIPTION
1	1	483062	3.00 ID X 4.62 OD X .125T WASH
2	1	358564	FRT LEG LWR NYL SLEEVE 280 89
3	1	358565	FRT LEG UPR NYL SLEEVE 280 89
4	1	359175	RF/LR INNER LEG WLD, 284XP 02
5	4	358927	LWR BRG KPR, LEG 98
6	1	358957	LH REAR OUTER LEG WLD,2100 99
7	1	358971	STEERING ARM WLD,RF/LR 2100 99
8	1	358980	AIR BAG MT WLD, RF/LR 2100 99
9	1	358985	AIR BAG ARCH WLD,RF/LR 2100 99
10	1	358994	LEG WASHER, NYLON 2100 99
11	1	358995	NYLON BEARING,LWR AB MT2100 99
12	2	900069	5/16UNC X 2" HEX BOLT
13	2	470259	URETHANE BUMPER,1.25D X 1.25L
14	1	470265	KEY, .250 X .375 X 1.88 LG
15	1	471005	1/4 28 X 1/2 GREASE ZERK
16	2	471023	GREASE ZERK 1/4-28 X 45
17	1	473906	SPIRAL PIN, 1/2 X 2 1/2 LG
18	1	483061	1.65 ID X 2.50 OD X .188T WASH
19	8	900064	5/16UNC X 3/4 HEX BOLT
20	4	900264	1/2UNC X 1 1/4 HEX BOLT
21	4	900265	1/2UNC X 1 1/2 HEX BOLT
22	4	900267	1/2UNC X 2" HEX BOLT
23	1	900390	5/8UNC X 2 1/2 SOCKET CAP SCR
24	4	900836	5/8UNF X 3 1/4 HEX BOLT GR8
25	3	910008	1/2UNC HEX NUT
26	8	914008	1/2UNC HEX STOVER NUT
27	14	914811	5/8UNF HEX NUT GR8
28	8	920501	5/16 LOCK WASHER
29	5	920504	1/2 LOCK WASHER
30	1	920505	5/8 LOCK WASHER
31	1	358759	LEG MT V-PLT WLD, 284T 94
32	1	358831	AIRIDE SPRING 98
33	1	358832	AIRIDE SPRING CTRL VALVE 98
34	1	358839	AIRIDE CTRL LINK KIT, 2100 99
35	2	358990	NYLON GUIDE, 2100 LEG 99
36	1	358991	INNER KEEPER,NYL GUIDE,2100 99
37	1	358992	OUTER KEEPER,NYL GUIDE,2100 99
38	1	358993	NYLON GUIDE BACK PLATE,2100 99
39	2	470118	1/4UNC X 3/4 FLANGE HEX BOLT
40	2	470121	1/4UNC HEX FLANGE LOCK NUT
41	3	900837	5/8UNF X 3 1/2 HEX BOLT GR8
42	2	910002	5/16UNC HEX NUT
43	1	910013	3/4UNF HEX NUT
44	2	914002	5/16UNC HEX STOVER NUT
45	1	920506	3/4 LOCK WASHER
46	1	711040	1/4MNPT-90-1/4 NYL TUBE LBO
47	2	711036	1/8MNPT-1/4 NYL TUBE FTG
48	1	601413	HOSE, 1/4 X 8 AIR
49	2	900065	5/16UNC X 1" HEX BOLT
50	1	342828	NYL HOSE SLEEVE,3.34ID X 65.00
51	1	483063	1.65 ID X 2.50 OD X .074T WASH
52	1	342654	NYL HOSE SLEEVE,3.66ID X 24.00

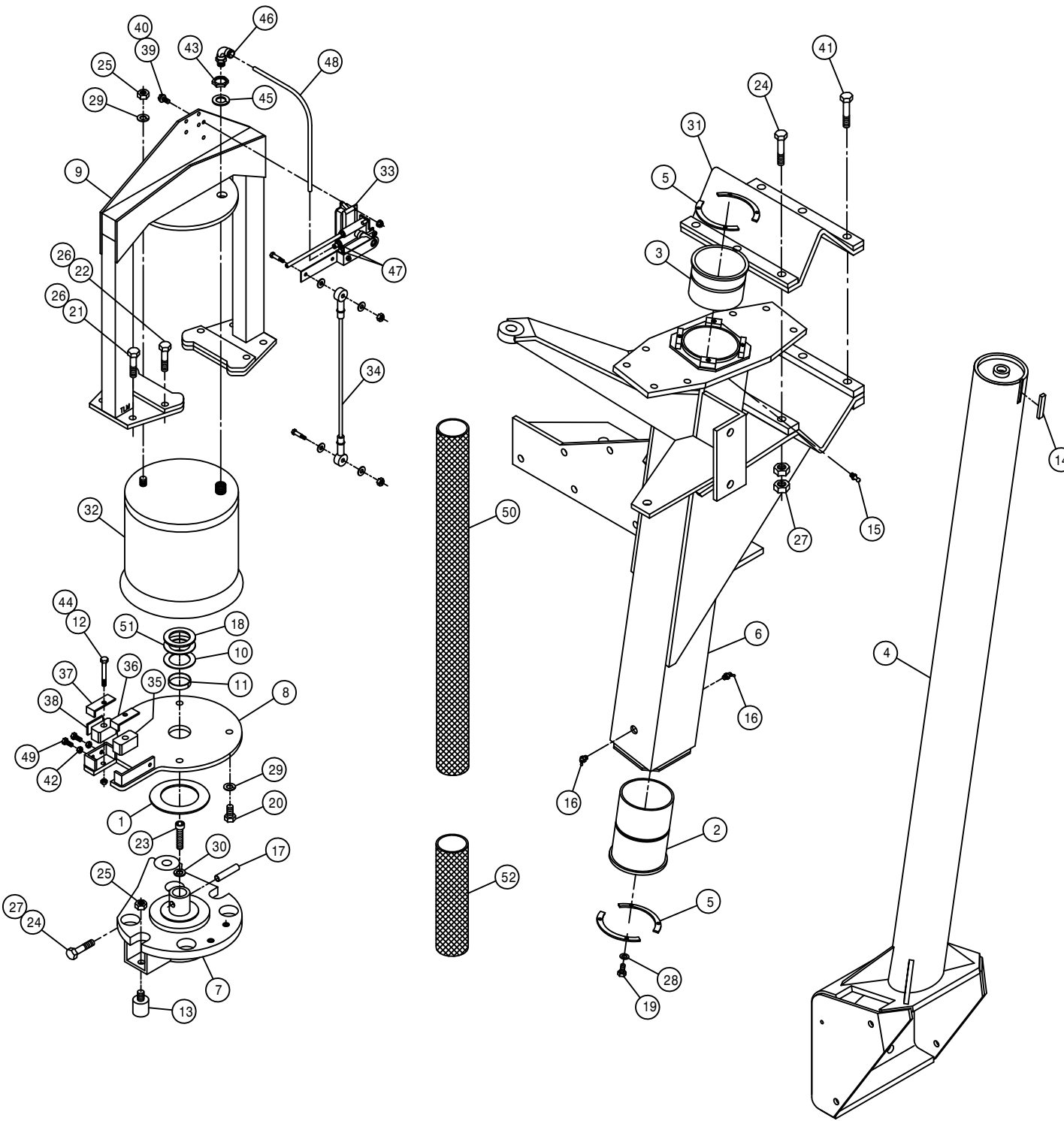



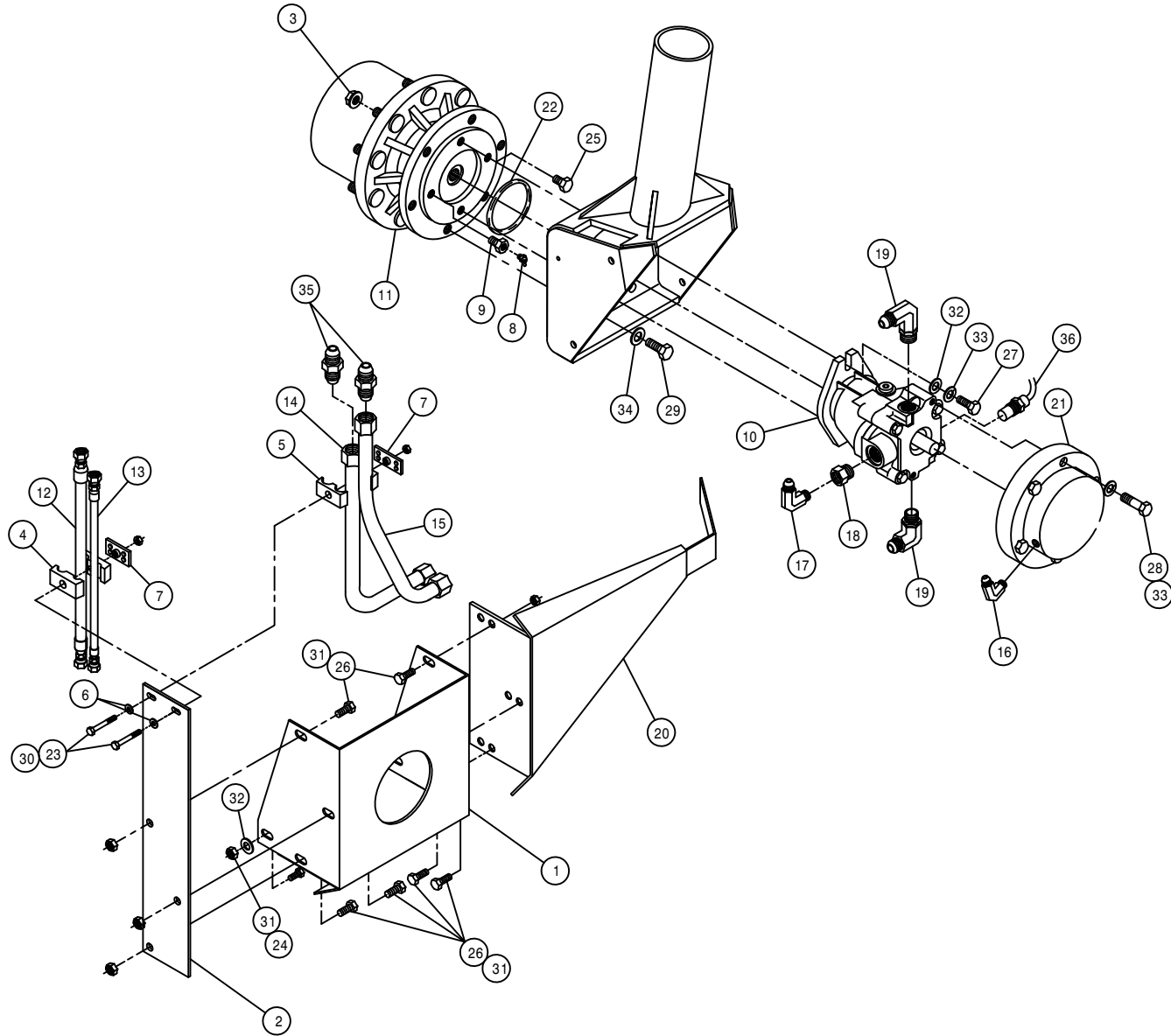

LEFT REAR LEG ASSEMBLY

DET.	QTY	PART NO.	DESCRIPTION
1	1	359186	REAR WHL MTR SHLD, 284XP 2002
2	1	359137	REAR HYD TUBE MTG PLT 284XP
3	9	470140	5/8UNF HEX SMTH FLANGE NUT PLT
4	1	470270	HOSE CLAMP BODY, .530-.680
5	1	470275	TUBE CLAMP BODY, 1.000-1.000
6	1	920001	5/16 SAE FLAT WASHER
7	2	470278	CLAMP WELD PLATE, SNGL, 2.75LG
8	1	471023	GREASE ZERK 1/4-28 X 45
9	1	610556	1/2UNC X 1/2 ZERK BOLT T-HUB
10	1	610621	SUND M35-3102 WHL MTR
11	1	610692	TORQ HUB, 30:1 B-MT MW3BA
12	1	614101	04C1T-06FJX-06FJX-133 H/A
13	1	614549	06C1T-06FJX-06FJX-140 H/A
14	1	615796	REAR LEG HYD TUBE ASSY XP
15	1	615798	LH REAR LEG HYD TUBE ASSY XP
16	1	618114	9/16MJIC-90-7/16MOR LBO
17	1	618119	9/16MJIC-90-9/16MOR LBO
18	1	618172	7/8MOR-9/16FOR ADPTR
19	2	618576	1 5/16MJIC-90-1 1/16MOR LBO
20	1	662256	STALK GUIDE WLD, 2100 2000
21	1	828092	MICO HYD BRAKE
22	1	870045	O-RING 4 1/8 OD X 4 ID
23	2	900086	5/16UNC X 2 1/4 HEX BOLT
24	2	900263	1/2UNC X 1" HEX BOLT
25	1	900260	1/2UNC X 1/2 H BOLT GR2 UNPLT
26	6	900264	1/2UNC X 1 1/4 HEX BOLT
27	2	900265	1/2UNC X 1 1/2 HEX BOLT
28	2	900268	1/2UNC X 2 1/2 HEX BOLT
29	6	900333	5/8UNC X 1 1/2 HEX BOLT
30	2	914002	5/16UNC HEX STOVER NUT
31	8	914008	1/2UNC HEX STOVER NUT
32	4	920004	1/2 SAE FLAT WASHER
33	4	920504	1/2 LOCK WASHER
34	6	920505	5/8 LOCK WASHER
35	2	618577	1 5/16MJIC UNION
36	1	610625	SENSOR, WHL MOTOR 610621/610671

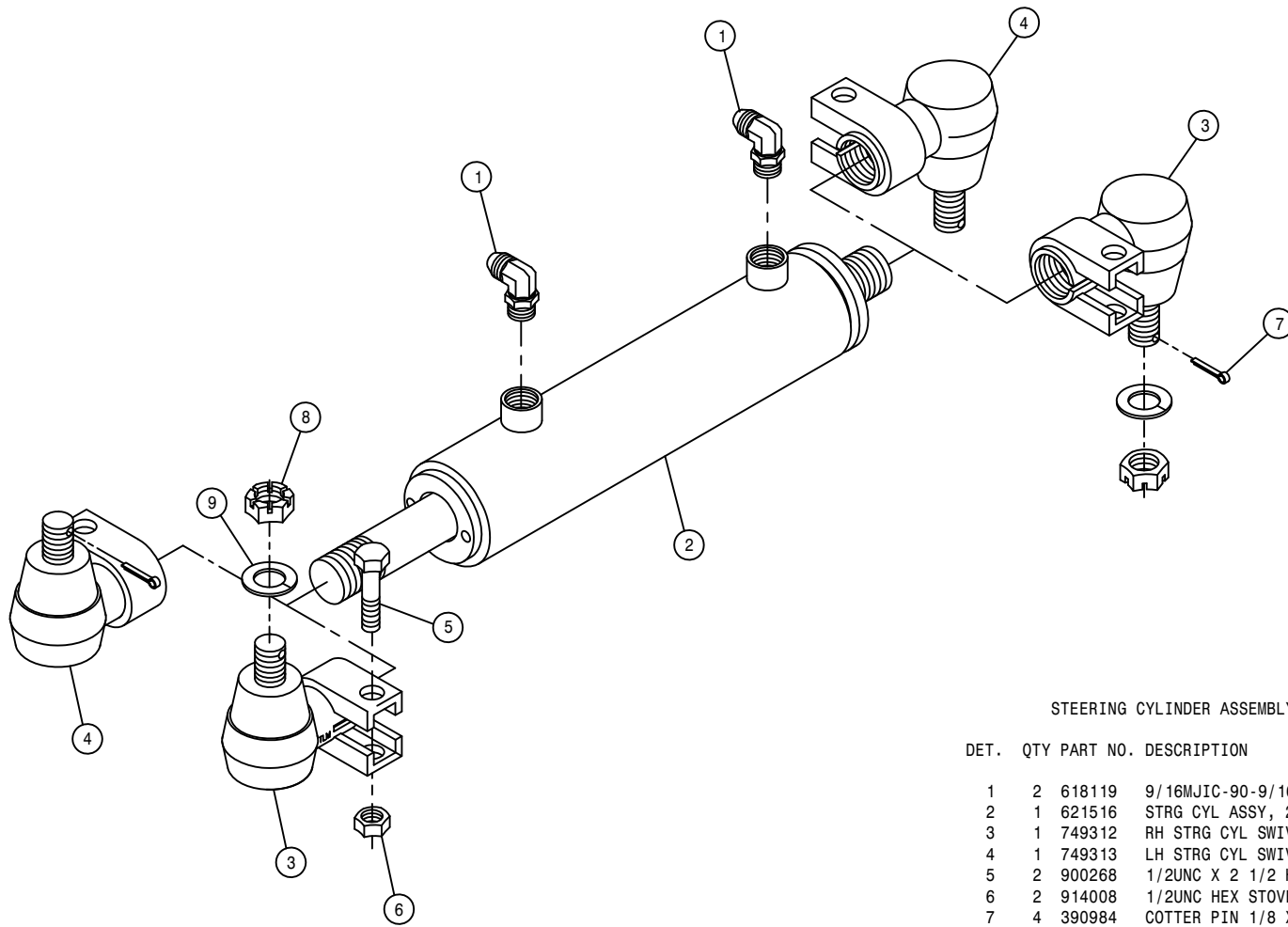

STEERING CYLINDER ASSEMBLY

DET.	QTY	PART NO.	DESCRIPTION	
	1	2	618119	9/16MJIC-90-9/16MOR LBO
	2	1	621516	STRG CYL ASSY, 2100
	3	1	749312	RH STRG CYL SWIV ASSY
	4	1	749313	LH STRG CYL SWIV ASSY
	5	2	900268	1/2UNC X 2 1/2 HEX BOLT
	6	2	914008	1/2UNC HEX STOVER NUT
	7	4	390984	COTTER PIN 1/8 X 1 1/4
	8	2	822040	5/8-18UNF SLOTTED HEX NUT
	9	2	920505	5/8 LOCK WASHER
	NS	1	621517	REPAIR KIT, HYD CYL 621516

NOTE: 1. 621205 - RH STEERING CYLINDER ASSEMBLY W/CYL SWIV DET.3  
 2. 621206 - LH STEERING CYLINDER ASSEMBLY W/CYL SWIV DET.4

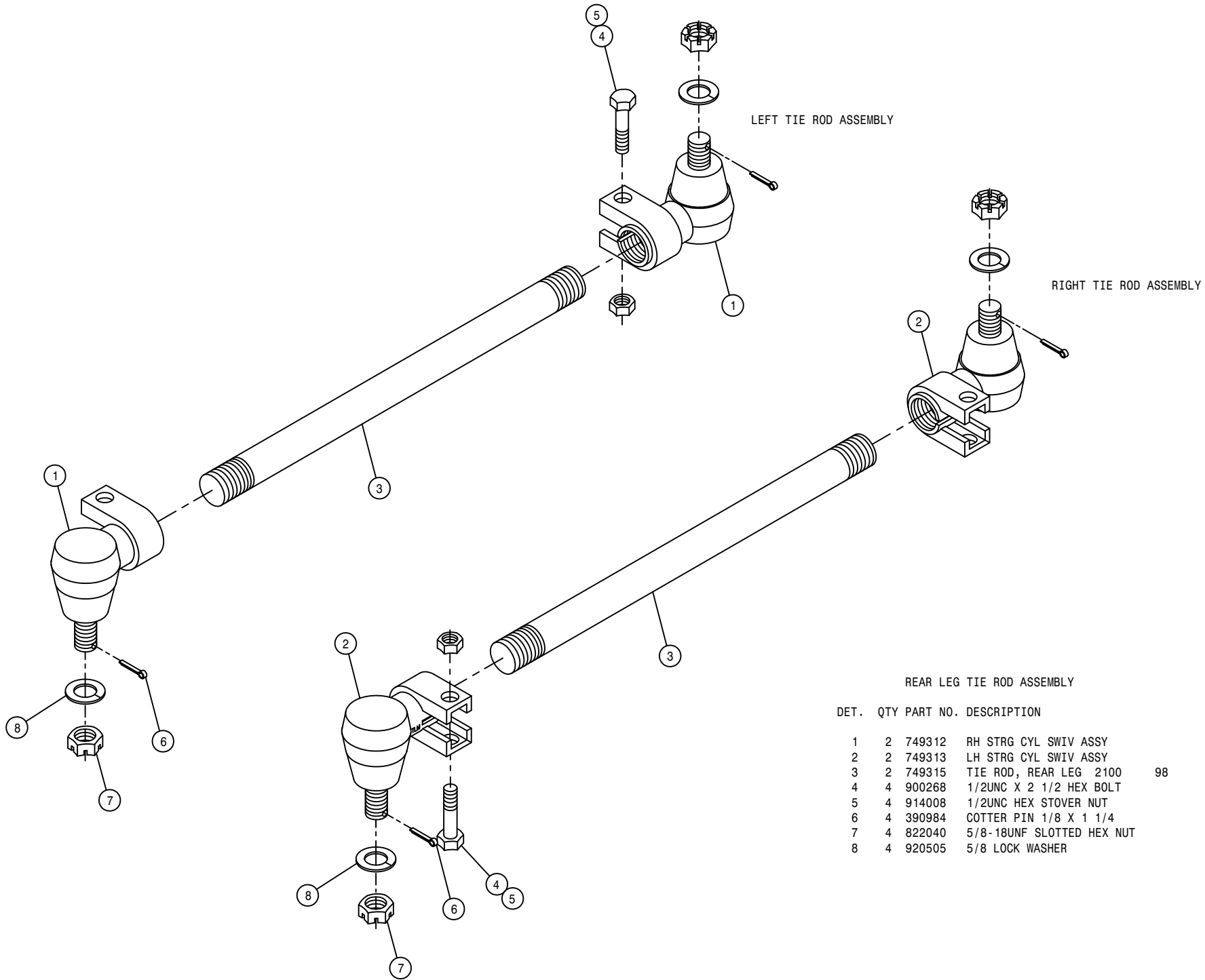

REAR LEG TIE ROD ASSEMBLY

DET.	QTY	PART NO.	DESCRIPTION	
	2	749312	RH STRG CYL SWIV ASSY	
	2	749313	LH STRG CYL SWIV ASSY	
	2	749315	TIE ROD, REAR LEG 2100	98
	4	900268	1/2UNC X 2 1/2 HEX BOLT	
	4	914008	1/2UNC HEX STOVER NUT	
	4	390984	COTTER PIN 1/8 X 1 1/4	
	4	822040	5/8-18UNF SLOTTED HEX NUT	
	4	920505	5/8 LOCK WASHER	

CAB ASSEMBLY

DET.	QTY	PART NO.	DESCRIPTION
1	1	290107	GROUND CABLE,8" X 4GA .406LUGS
2	4	311051	RUBBER MOUNT, RB3-350
3	4	311052	SNUBBING WASHER FOR 311051
4	24	193037	STICKERTITE 1/8 X 3/4
5	42	193044	WINDOW WEATHERSTRIP
6	42	193045	LOCK STRIP FOR 193044
7	1	290003	WINDSHIELD WASHER NOZZLE KIT
8	1	291569	3/8 X 6" HEAT SHRINK TUBE
9	1	200019	.25 SCH 40BP X 1.00 LG C/L
10	1	202037	WINDSHIELD WIPER SPACER
11	1	290412	DIMMER SWITCH
12	1	290417	18" WIPER BLADE
13	4	900343	5/8UNC X 4 1/2 HEX BOLT
14	1	343206	CAB WELDMT, 284XP 2002
15	1	342146	KICK PANEL WLD, 284 CAB 94
16	1	342150	CAB ROOF WLD, 284 94
17	1	342180	HEADLINER KPR ANGLE,284CAB 94
18	4	470067	GROMMET, .250ID .125GW .375GD
19	2	470070	GROMMET, .375ID .062GW .500GD
20	4	914010	5/8UNC HEX STOVER NUT
21	1	470229	IDENTIFICATION TIE, WHITE
22	6	470100	3/8 INT TOOTH LOCK WASHER
23	13	470121	1/4UNC HEX FLANGE LOCK NUT
24	10	470122	1/4UNC X 1/2 FLANGE HEX BOLT
25	28	470212	1/4 BONDED SEALING WASH, SS
26	16	470218	1/4UNC NUT J-TYPE CAGE CLIP
27	1	470222	GRAB HANDLE, BLACK MOULDED
28	12	472349	1/4 X 3/4 20THD-IN TEK TYPE
29	6	473779	10MM-1.50 HEX NUT
30	2	473910	1/4 X 1 1/2 PHIL HD SHT MTL S
31	2	650524	OUTSIDE MIRROR W/MTG BRKT
32	1	658008	WINDSHIELD WIPER MOTOR
33	1	658013	WIPER ARM
34	1	658014	FRONT CAB GLASS 94
35	1	658015	FRONT SIDE CAB/DOOR GLASS 94
36	2	658016	REAR SIDE CAB GLASS 94
37	1	658017	REAR CAB GLASS 94
38	8	900002	1/4UNC X 3/4 HEX BOLT
39	1	900005	1/4UNC X 1 1/2 HEX BOLT
40	6	291603	HALOGEN WORKLAMP,SIDE MT 12V
41	2	903883	10-32 X 1/2 SLT RDHD MACH SCR
42	2	903889	10-32 X 3/4 SLT RDHD MACH SCR
43	4	470175	10-32 HEX FLANGE LOCK NUT
44	14	195913	7/64" WINDSHIELD WASHER HOSE
45	1	914000	1/4UNC HEX STOVER NUT
46	1	914004	3/8UNC HEX STOVER NUT
47	2	342333	NYL HOSE SLEEVE,2.64ID X 12.00
48	1	629728	FINISH PLUG FOR 2.12 HOLE
49	11	470118	1/4UNC X 3/4 FLANGE HEX BOLT
50	2	659704	FOAM, 2"THK X 2" WIDE X 42"LG

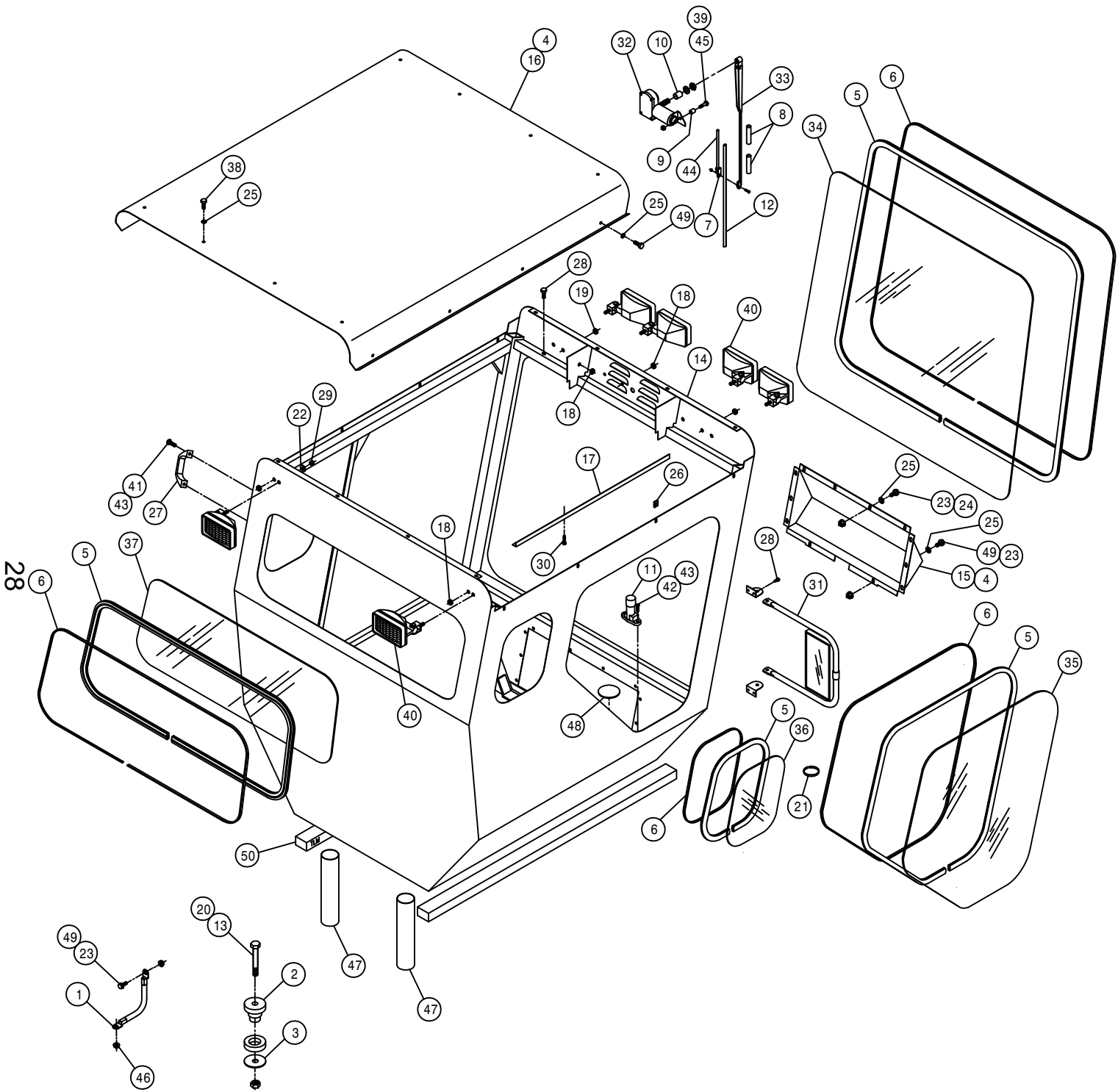

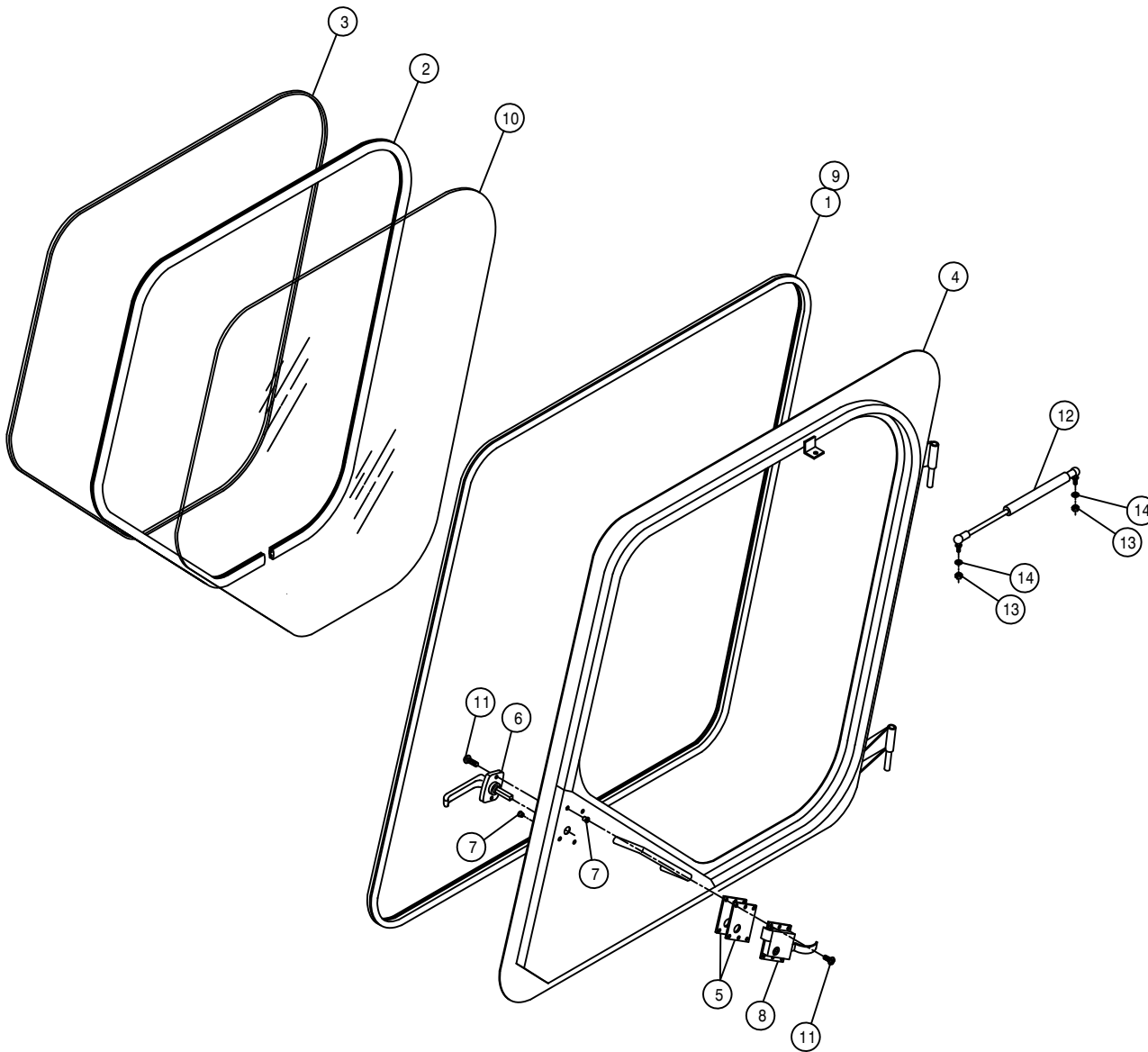

DOOR ASSEMBLY

DET. QTY PART NO. DESCRIPTION

1	12	193028	PUSH-ON TRIM SEAL RS-130-FX
2	9	193044	WINDOW WEATHERSTRIP
3	9	193045	LOCK STRIP FOR 193044
4	1	342153	LH DOOR WLD, 284 CAB 94
5	2	342163	CAB DOOR LATCH SHIM, .06 94
6	1	342217	DOOR HANDLE, 254/284 CAB 94
7	6	470165	10-32 NUTSERT .020-.100 MATL
8	1	470219	CAB LOCK, LH #55
9	2	485052	POP RIVET 1/8 X 3/8
10	1	658015	FRONT SIDE CAB/DOOR GLASS 94
11	6	903710	10-32X5/8 PHIL PANHD MACH SCR
12	1	470221	GAS SPRING, 60LB 3.5 STROKE
13	2	910002	5/16UNC HEX NUT
14	2	920501	5/16 LOCK WASHER

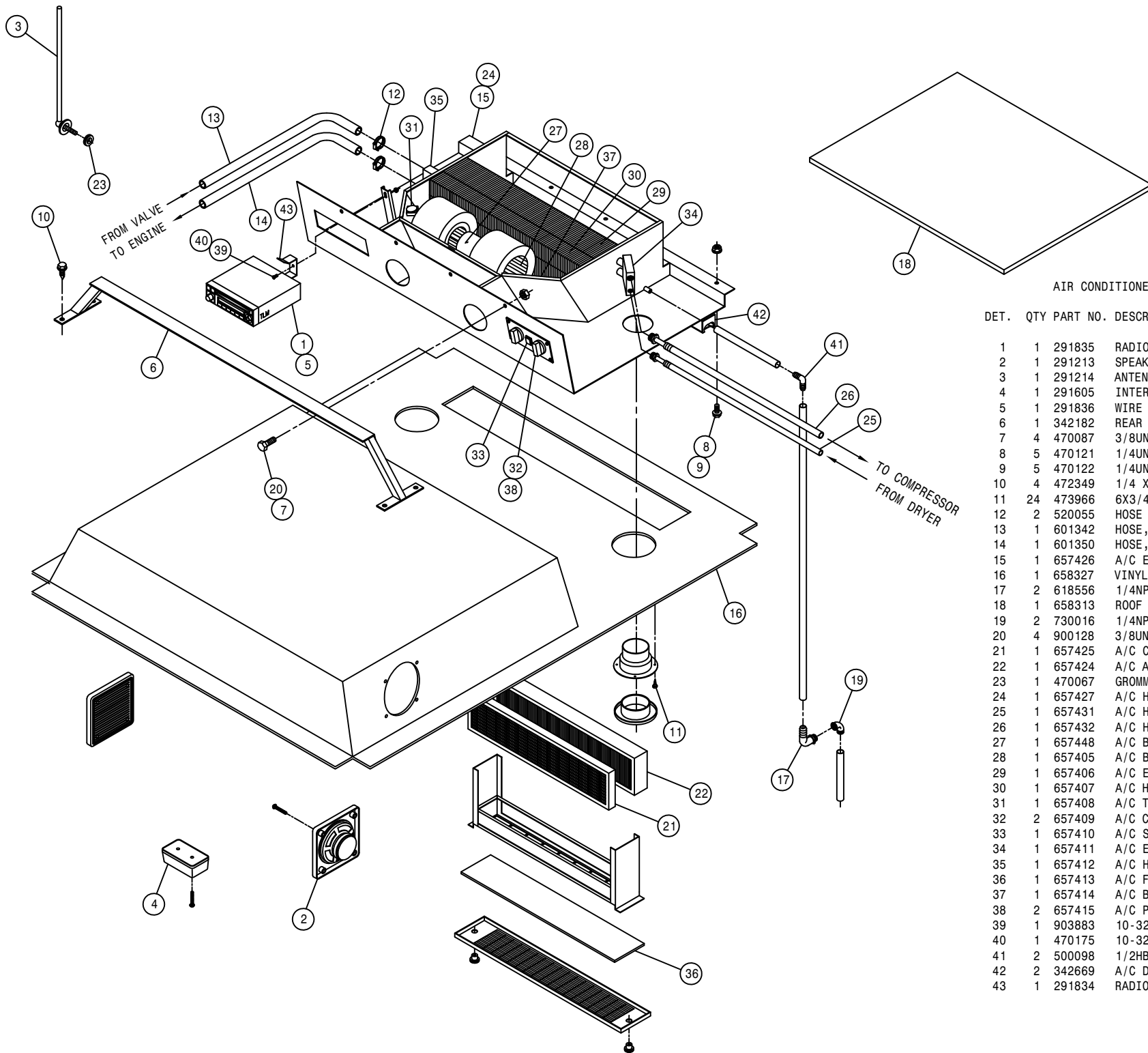

AIR CONDITIONER ASSEMBLY

DET.	QTY	PART NO.	DESCRIPTION
1	1	291835	RADIO, AM/FM/CD/WB CRC-5320
2	1	291213	SPEAKERS (PAIR)
3	1	291214	ANTENNA
4	1	291605	INTERIOR LIGHT W/SWITCH
5	1	291836	WIRE HARNESS FOR 291835 RADIO
6	1	342182	REAR A/C BLOWER MT WLD,CAB 94
7	4	470087	3/8UNC HEX FLANGE LOCK NUT
8	5	470121	1/4UNC HEX FLANGE LOCK NUT
9	5	470122	1/4UNC X 1/2 FLANGE HEX BOLT
10	4	472349	1/4 X 3/4 20THD-IN TEK TYPE
11	24	473966	6X3/4 PHIL FLT HD SHT MTL SCR
12	2	520055	HOSE CLAMP NO 12 STAINLESS
13	1	601342	HOSE, 5/8 X 192 HEATER
14	1	601350	HOSE, 5/8 X 160 HEATER
15	1	657426	A/C EVAPORATOR/HEATER, 284
16	1	658327	VINYL HEAD LINER
17	2	618556	1/4NPT-90-1/2 HOSE BARB,POLY
18	1	658313	ROOF SEAL,AIR COND 204,254,284
19	2	730016	1/4NPT ST EL, 90 DEG POLY
20	4	900128	3/8UNC X 3/4 HEX BOLT
21	1	657425	A/C CHARCOAL AIR FILTER
22	1	657424	A/C AIR FILTER
23	1	470067	GROMMET, .250ID .125GW .375GD
24	1	657427	A/C HOSE KIT, EVAP 284, 99
25	1	657431	A/C HOSE ASSY, 5/16 X 173
26	1	657432	A/C HOSE ASSY, 1/2 X 190.
27	1	657448	A/C BLOWER ASSY, 12V KENWAY
28	1	657405	A/C BLOWER WHEEL W/CLIP
29	1	657406	A/C EVAPORATOR COIL
30	1	657407	A/C HEATER COIL
31	1	657408	A/C THERMOSTAT
32	2	657409	A/C CONTROL KNOB
33	1	657410	A/C SWITCH, PUSH ON-OFF
34	1	657411	A/C EXPANSION VALVE
35	1	657412	A/C HEATER VALVE,4-WAY MTRIZED
36	1	657413	A/C FILTER, RECIRCULATION
37	1	657414	A/C BLOWER DRIVE ASSY
38	2	657415	A/C POTENTIOMETER ASSY
39	1	903883	10-32 X 1/2 SLT RDHD MACH SCR
40	1	470175	10-32 HEX FLANGE LOCK NUT
41	2	500098	1/2HB-90-1/2 HOSE BARB, POLY
42	2	342669	A/C DRAIN HOSE KEEPER
43	1	291834	RADIO SUPPORT BRKT

30

298030

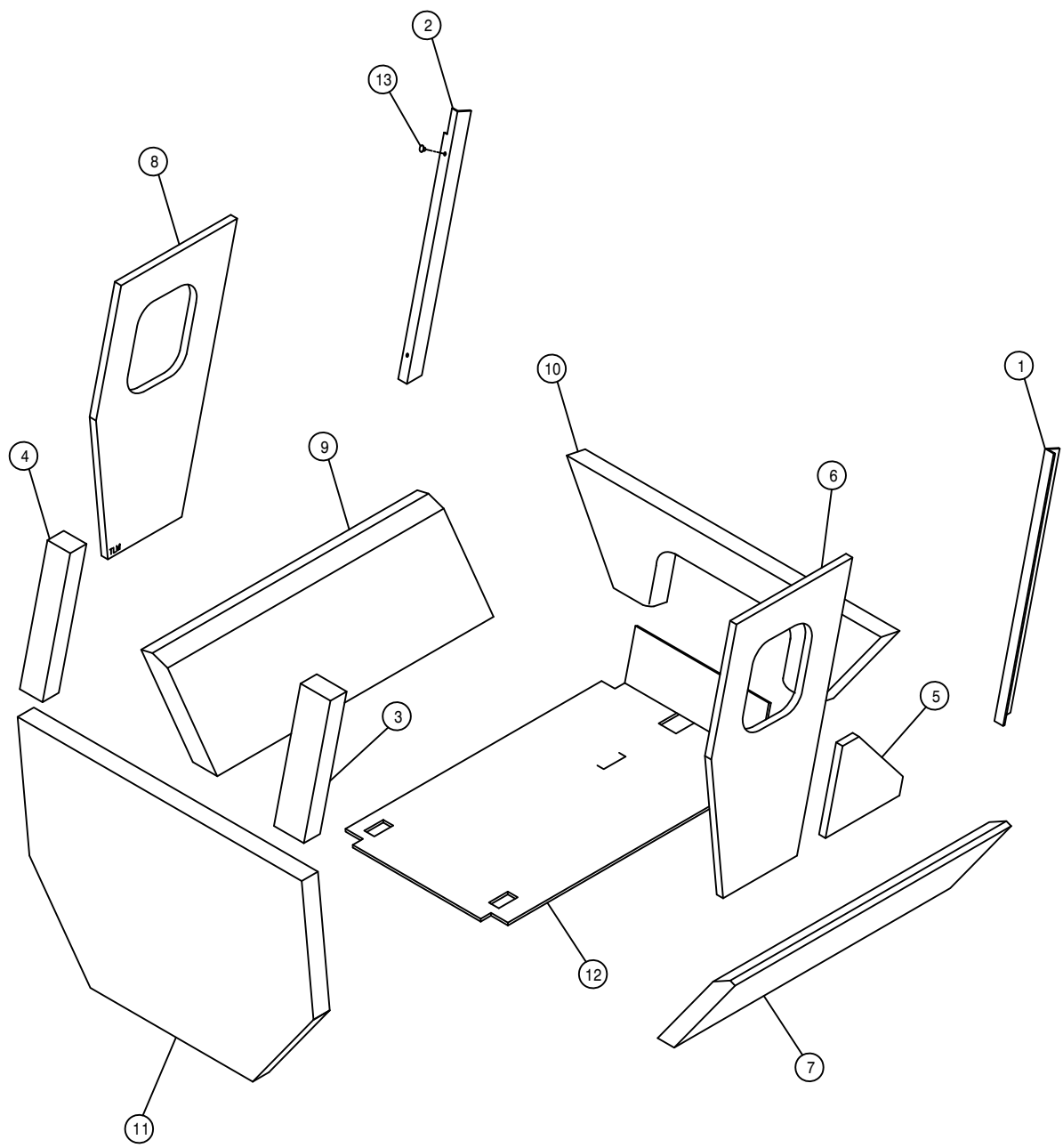

CAB FOAM

DET.	QTY	PART NO.	DESCRIPTION
1	1	658301	VINYL POST COVER, RH FRONT 94
2	1	658302	VINYL POST COVER, LH FRONT 94
3	1	658303	VINYL POST COVER, RH REAR 94
4	1	658304	VINYL POST COVER, LH REAR 94
5	1	658305	VINYL SIDE PANEL, RH 94
6	1	658306	VINYL SIDE PANEL, RH UPPER 94
7	1	658307	VINYL SIDE PANEL, RH LOWER 94
8	1	658308	VINYL SIDE PANEL, LH UPPER 94
9	1	658309	VINYL SIDE PANEL, LH LOWER 94
10	1	658310	VINYL FRONT COVER PANEL 94
11	1	658311	VINYL REAR COVER PANEL 94
12	1	658328	FLOORMAT, 284XP CAB 2002
13	2	470225	TRIM CLIP, 11/16 BLK NYL HEAD

STEERING POST ASSEMBLY

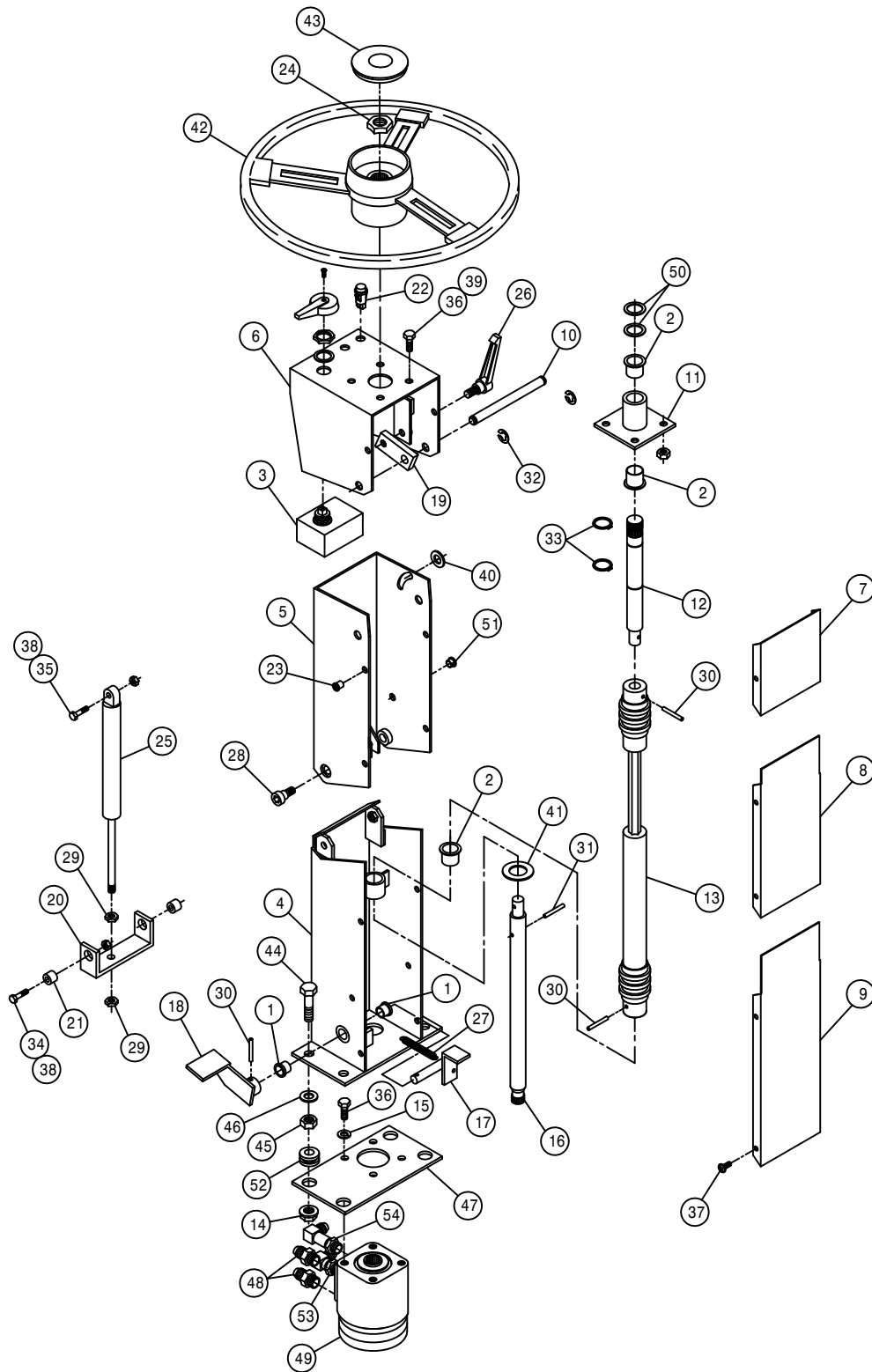

DET.	QTY	PART NO.	DESCRIPTION
	1	2	127502 NYLON FLANGE BRG
	2	3	127503 NYLINER FLG BRG, .875 ID
	3	1	291088 FLASHER / TURN SIGNAL SWITCH
	4	1	342450 LWR STRG COLUMN WLD, 2100 98
	5	1	342454 UPPER STRG COLUMN WLD, 2100 98
	6	1	342461 STRG WHL MT WLD, 2100 98
	7	1	342467 UPPER STRG COLUMN COVER, 2100 98
	8	1	342468 CNTR STRG COLUMN COVER, 2100 98
	9	1	342469 LWR STRG COLUMN SHLD
	10	1	342470 STRG COLUMN PIVOT PIN, 2100 98
	11	1	342471 STRG COL BRG HSG WLD, 2100 98
	12	1	342474 UPPER STEERING SHAFT, 2100 98
	13	1	470285 DOUBLE UNIVERSAL JOINT DRIVER
	14	4	470345P 1/2UNC HEX SMTH FLNG LOCK NUT
	15	4	920502 3/8 LOCK WASHER
	16	1	342483 LWR STEERING SHAFT, 2100 98
	17	1	342484 FOOT PEDAL PIV PIN WLD, 2100 98
	18	1	342487 FOOT PEDAL WLD, 2100 98
	19	1	342490 STRG PIVOT LOCK, 2100 98
	20	1	342491 LWR AIR SHOCK PIVOT, 2100 98
	21	2	342492 LWR AIR SHOCK PIV BUSH, 2100 98
	22	2	390318 INDICATOR LIGHT, RED
	23	10	470086 1/4UNC NUTSERT .020-.100MATL
	24	1	470157 13/16-20UNEF HEX NUT STRG WHL
	25	1	470252 GAS SPRING, LOCKING 0350N
	26	1	470257 ADJ HANDLE, 3/8-16 STUD, BLACK
	27	1	470268 SPRING, EXTENSION, .50 X 1.75
	28	2	470283 3/8UNC 1/2 SCKT SHLDR BOLT
	29	2	473830 10MM-1.00 HEX JAM NUT
	30	3	473928 ROLL PIN, 3/16 X 1
	31	1	473936 ROLL PIN, 3/16 X 1 1/4
	32	2	629525 RING, RETAINING, .50DIA SHAFT
	33	2	629533 SNAP RING, 7/8 EXTRN
	34	2	900065 5/16UNC X 1" HEX BOLT
	35	1	900067 5/16UNC X 1 1/2 HEX BOLT
	36	8	900128 3/8UNC X 3/4 HEX BOLT
	37	10	903708 1/4UNC X 1/2 PHIL PNHD MACHSCR
	38	3	914002 5/16UNC HEX STOVER NUT
	39	4	914004 3/8UNC HEX STOVER NUT
	40	1	920002 3/8 SAE FLAT WASHER
	41	1	920007 7/8 SAE FLAT WASHER
	42	1	749294 STEERING WHEEL, VIP 14"
	43	1	749295 STRG WHL CAP W/HAGIE EMBLEM
	44	4	900267P 1/2UNC X 2" HEX BOLT
	45	4	470124P 1/2UNC HEX JAM NUT
	46	4	920004 1/2 SAE FLAT WASHER
	47	1	343211 STEERING MTR PLT, 284XP/2100 02
	48	2	618109 9/16MJIC-3/4MOR ADPTR
	49	1	749318 STRG MTR, 7.3CID, NON-LOAD 1031
	50	2	483031 1 3/8 X 7/8 X 18GA MACH WASHER
	51	1	470342 SNAP PLUG, BLK NYL, .375 DIA
	52	4	470346 GROMMET, .500ID .250GW, .812GD
	53	1	618115 9/16MJIC-90-3/4MOR LBO
	54	1	618709 9/16MJIC-90-3/4MOR EX LG LBO



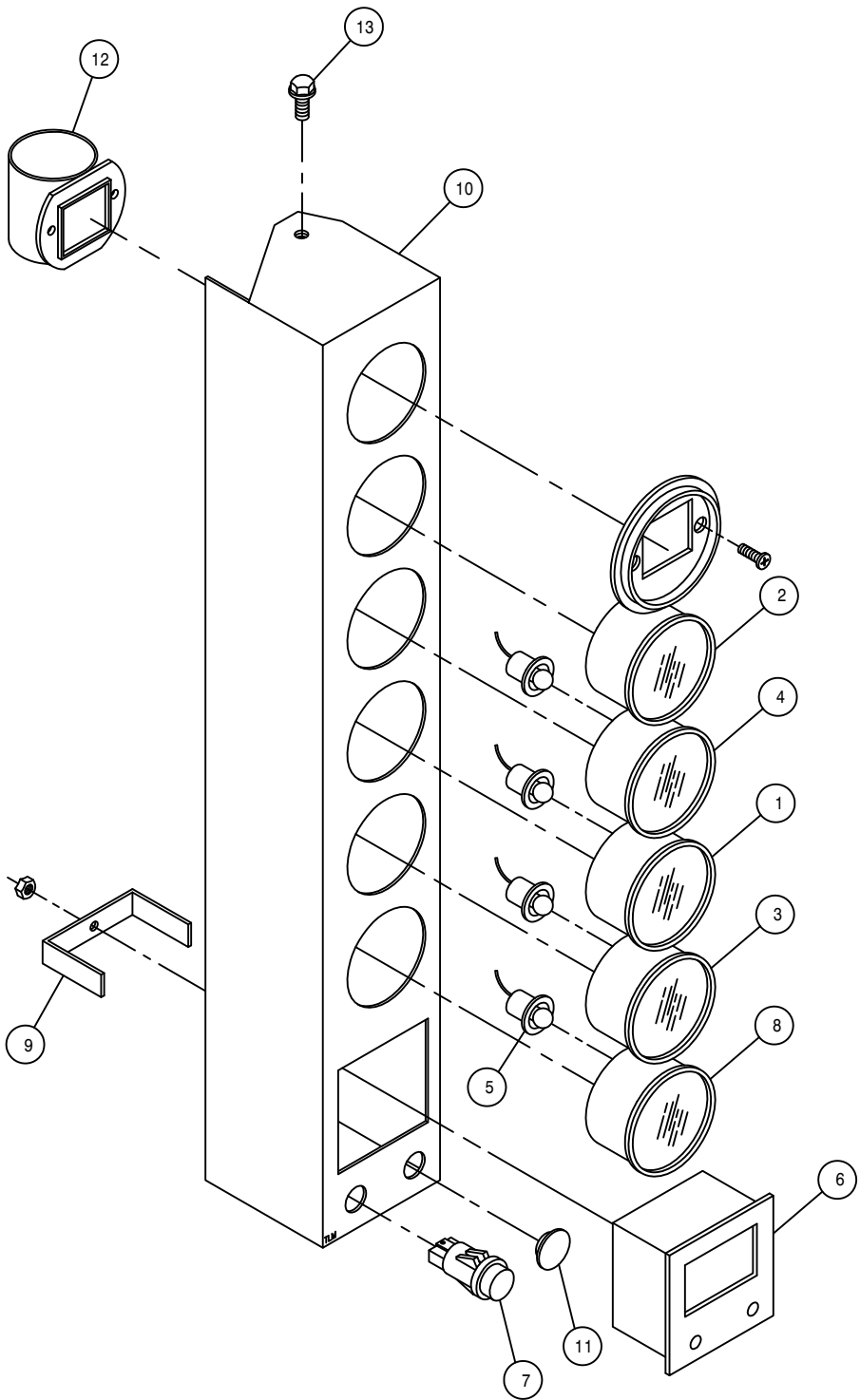

INSTRUMENT PANEL ASSEMBLY

DET.	QTY	PART NO.	DESCRIPTION
	1	290401	FUEL GAUGE FOR 2.125 DIA HOLE
	1	291203	HOUR METER, 12/24VDC BLACK BEZ
	1	291673	OIL PRESS GAUGE, 125PSI
	1	291611	VOLTMETER, 8V TO 18V DC
	4	291612	LIGHT KIT FOR 2" GAUGE
	1	291635	DIGITAL MPH/RPM INDICATOR
	1	291638	INDICATOR LIGHT, GREEN
	1	314436	TEMP GA 100-280 DEG LIGHTED
	1	342068	DIGITAL MPH/RPM IND KEEPER 94
	1	342186	INSTRU HSNGL WLD, 284 CAB 94
	1	658174	RUBBER BUMPER, 1.0000D .500GD
	1	314901	FILTER MINDER AIR RESTRICT GA
	2	470122	1/4UNC X 1/2 FLANGE HEX BOLT

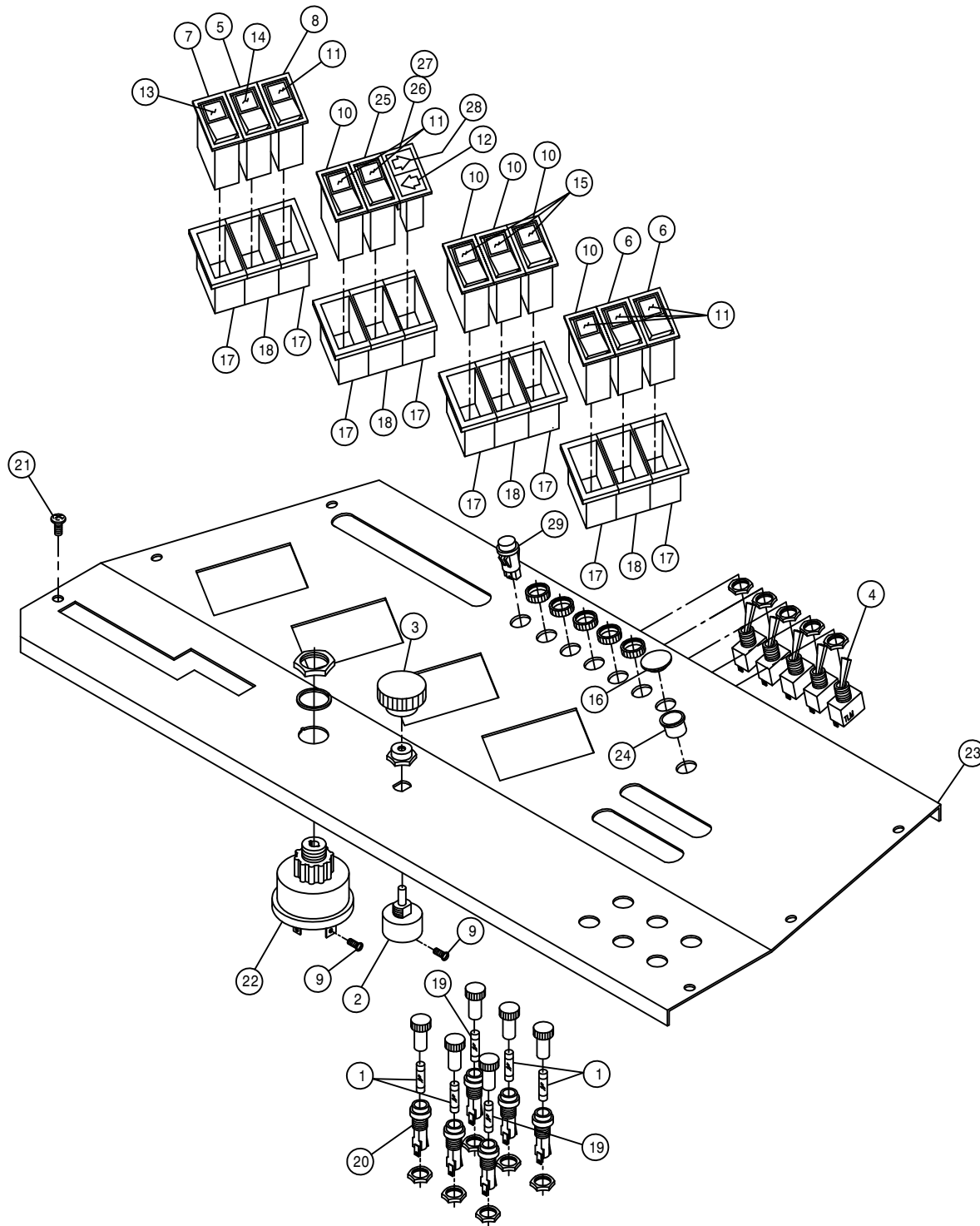

CONSOLE PANEL ASSEMBLY

DET.	QTY	PART NO.	DESCRIPTION
	4	291602	FUSE 10 AMP
	1	291606	ROTARY HEADLAMP SWITCH
	1	291607	SWITCH KNOB FOR 291606
	5	291608	TOGGLE SWITCH, ON-OFF, UNLIT
	1	291622	SWITCH, 1P ON/OFF 511-003
	2	291623	SWITCH, 2P ON/OFF 511-015
	1	291678	SWITCH, 511-115
	1	291625	SWITCH, 2P ON/ON 511-108
	2	903844	8-32 X 1/2 SLT RD HD MACH SCR
	5	291627	SWITCH, 2P(ON)OFF(ON) 511-058
	6	291628	LENS, GREEN 596-650
	1	291687	DIRECTION ARROW LENS, LH, YELLOW
	1	291630	LENS, WINDSHIELD WASHER, 594-701
	1	291631	LENS, HAZARD 595-417
	3	291632	LENS, DIRECTION INDICATOR
	1	658174	RUBBER BUMPER, 1.0000D .500GD
	8	293246	END BEZEL, 594-802
	4	293247	CENTER BEZEL, 594-801
	2	298004	20 AMP FUSE SFE 20
	6	298011	FUSE HOLDER
	6	903708	1/4UNC X1/2 PHIL PNHD MACHSCR
	1	321021	IGN SWITCH, NON-SEALED
	1	342657	CONSOLE COVER PNL, 284 CUMM 99
	1	470223	SNAP BUSHING, BLK NYL, .50DIA
	1	291672	SWITCH, 1P ON/OFF/ON 511-149
	1	291684	INDICATOR BASE W/LAMP 511-502
	2	291685	REFLECTOR INSERT, 592-544
	1	291686	DIRECTION ARROW LENS, RH, YELLOW
	1	390318	INDICATOR LIGHT, RED

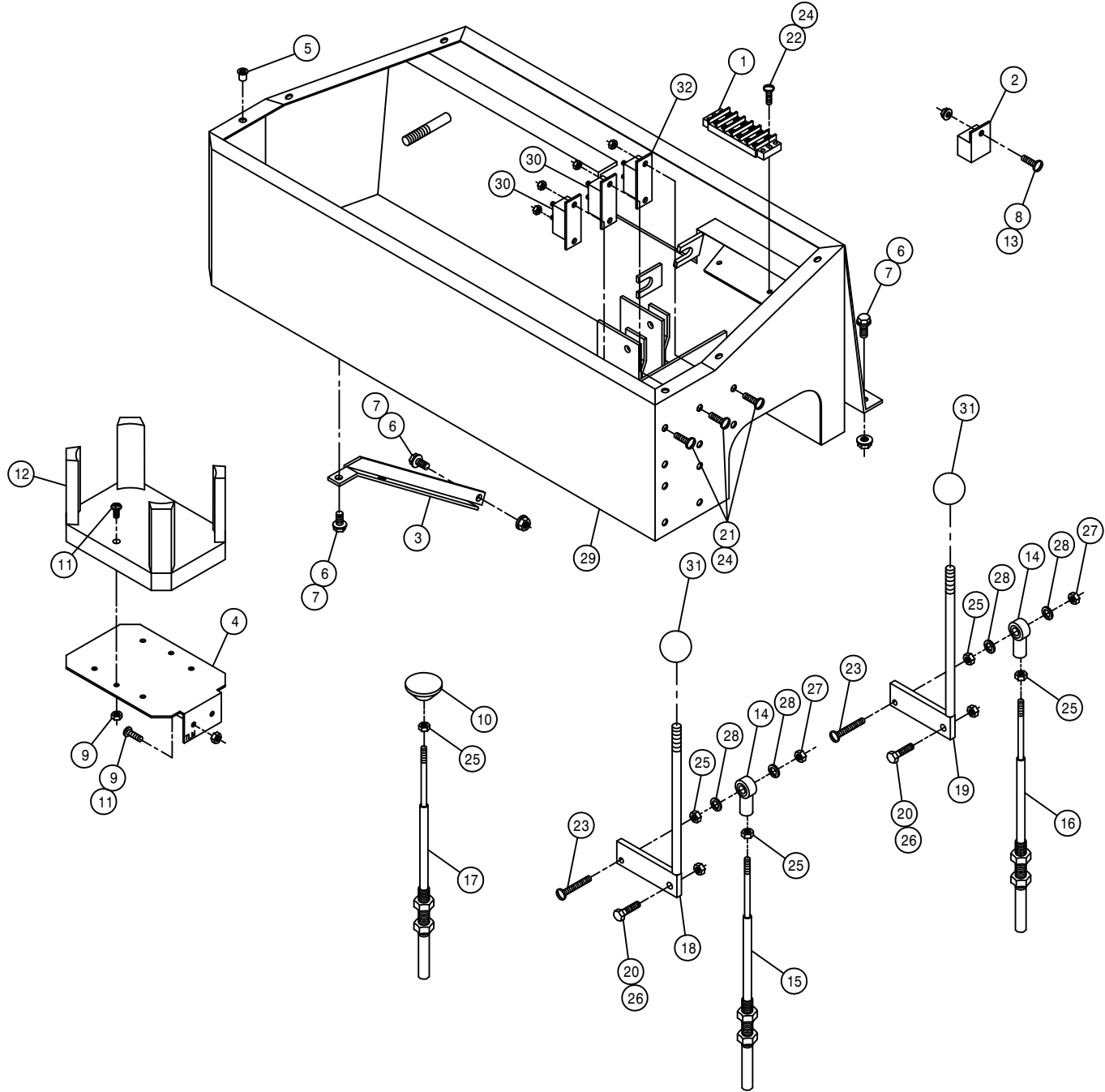

CONSOLE ASSEMBLY

DET.	QTY	PART NO.	DESCRIPTION
1	1	293093	TERMINAL BLOCK 6 POS - 2 ROW
2	1	291640	RELAY, 12V 20/30AMP BOSCH
3	1	342282	CONSOLE BRACE 254/284 95
4	1	342216	DRINK HOLDER MT BRKT 94
5	6	470086	1/4UNC NUTSERT .020-.100MATL
6	5	470118	1/4UNC X 3/4 FLANGE HEX BOLT
7	5	470121	1/4UNC HEX FLANGE LOCK NUT
8	1	903844	8-32 X 1/2 SLT RD HD MACH SCR
9	4	470175	10-32 HEX FLANGE LOCK NUT
10	1	470190	KNOB,1 3/8" LIFT, BLK 10-32
11	4	903710	10-32X5/8 PHIL PANHD MACH SCR
12	1	470214	SPILLMASTER DRINK HOLDER
13	1	910024	8-32 HEX NUT
14	2	473921	BALL JOINT NO 10-32 THD
15	1	785063	CTRL CABLE 10-32 2IN X 42 LG
16	1	785064	CTRL CABLE 10-32 2IN X 53 LG
17	1	785065	CTRL CABLE 10-32 4IN X 68 LG
18	1	785070	SOLU PRESS CTRL LEVER WLD 94
19	1	785073	AGIT CTRL LEVER WLD 94
20	2	900003	1/4UNC X 1" HEX BOLT
21	6	903812	6-32 X 1/2 SLT RD HD MACH SCR
22	2	903814	6-32 X 3/4 SLT RD HD MACH SCR
23	2	903893	10-32 X 1" SLT RD HD MACH SCR
24	8	910022	6-32 HEX NUT
25	5	910027	10-32 HEX NUT
26	2	914000	1/4UNC HEX STOVER NUT
27	2	914027	10-32 HEX STOVER NUT
28	4	920510	#10 LOCK WASHER
29	1	342191	CONSOLE WLD, 284 CAB 94
30	2	291197	CIRCUIT BREAKER,30AMP,INLINEMT
31	2	659291	KNOB,1" RND,BLK, 3/8-16
32	1	291024	CIRCUIT BREAKER,40AMP,INLINEMT

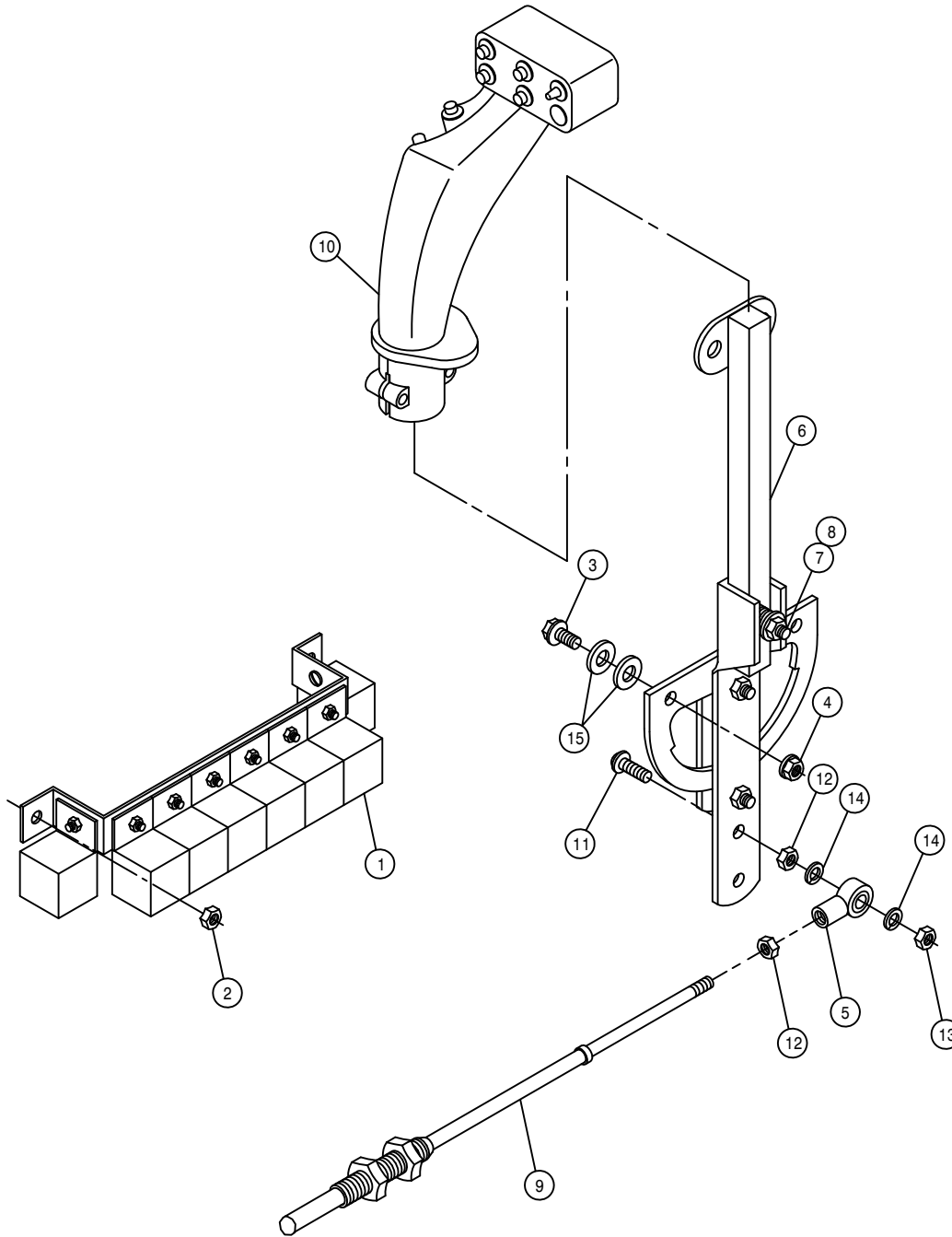

HYDROSTATIC LEVER ASSEMBLY

DET.	QTY	PART NO.	DESCRIPTION
	1	8	291640 RELAY, 12V 20/30AMP BOSCH
	2	2	470175 10-32 HEX FLANGE LOCK NUT
	3	2	470118 1/4UNC X 3/4 FLANGE HEX BOLT
	4	2	470121 1/4UNC HEX FLANGE LOCK NUT
	5	1	473921 BALL JOINT NO 10-32 THD
	6	1	606907 HYDST CTRL LEVER ASSY 204-284
	7	1	900005 1/4UNC X 1 1/2 HEX BOLT
	8	1	914000 1/4UNC HEX STOVER NUT
	9	1	785062 CTRL CABLE 10-32 4IN X 120 LG
	10	1	785083 FASSE EZ-3 CTRL HANDLE,284 04
	11	1	903893 10-32 X 1" SLT RD HD MACH SCR
	12	2	910027 10-32 HEX NUT
	13	1	914027 10-32 HEX STOVER NUT
	14	2	920510 #10 LOCK WASHER
	15	4	920000 1/4 SAE FLAT WASHER

THROTTLE LEVER ASSEMBLY

DET. QTY PART NO. DESCRIPTION

1	1	499001	SPRING HYDRO CONTROL
2	1	785007	KNOB, 1 3/16" BALL, RED, 3/8-16
3	1	785046	FRICTION DISC 3-333 X .38
4	1	785066	CTRL CABLE 10-32 4IN X 129 IN
5	1	785067	THROT LEVER WLD, GAS/DIESEL 94
6	1	903893	10-32 X 1" SLT RD HD MACH SCR
7	2	910027	10-32 HEX NUT
8	1	914004	3/8UNC HEX STOVER NUT
9	1	914027	10-32 HEX STOVER NUT
10	1	920002	3/8 SAE FLAT WASHER
11	2	920510	#10 LOCK WASHER
12	1	473921	BALL JOINT NO 10-32 THD

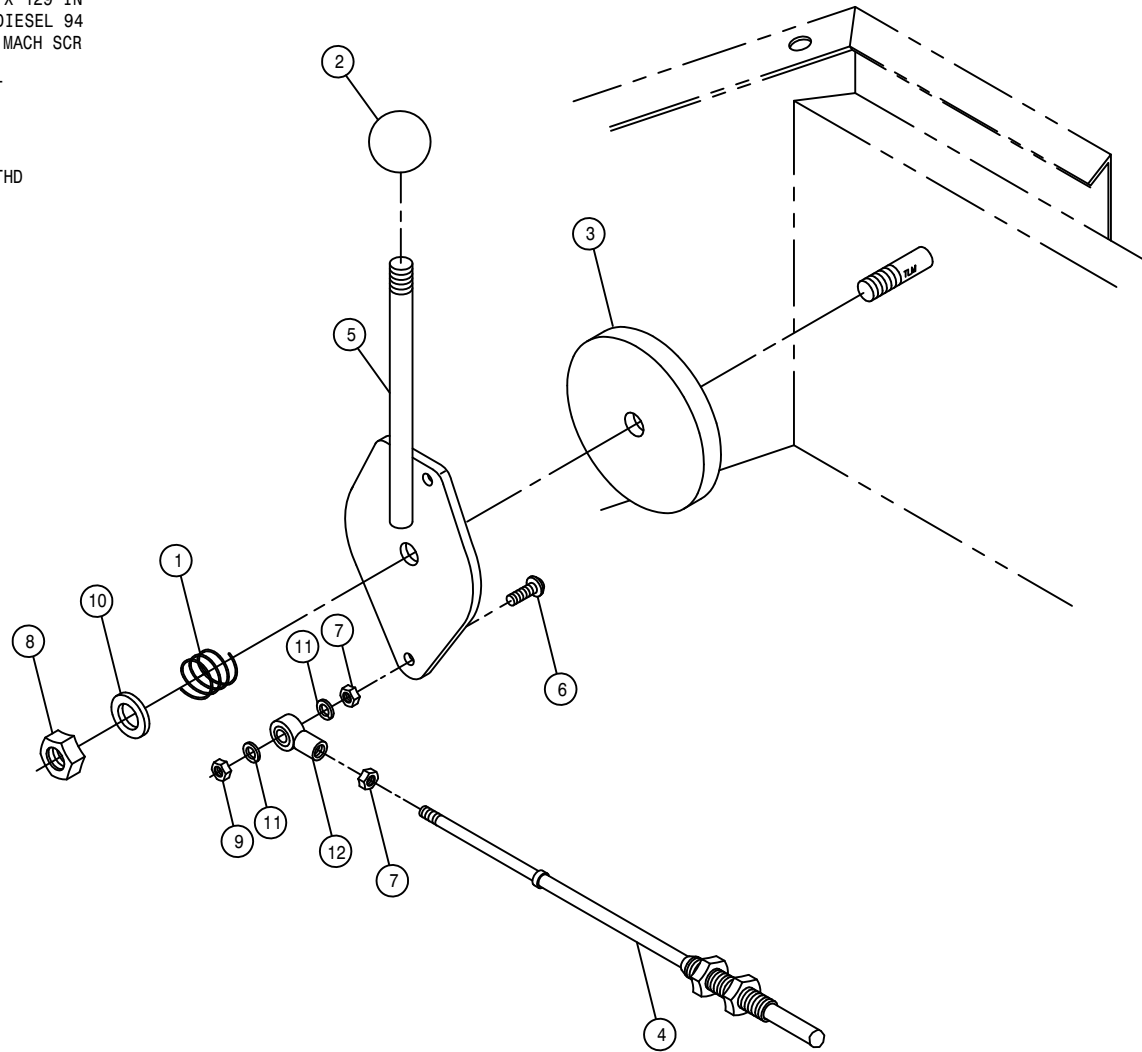

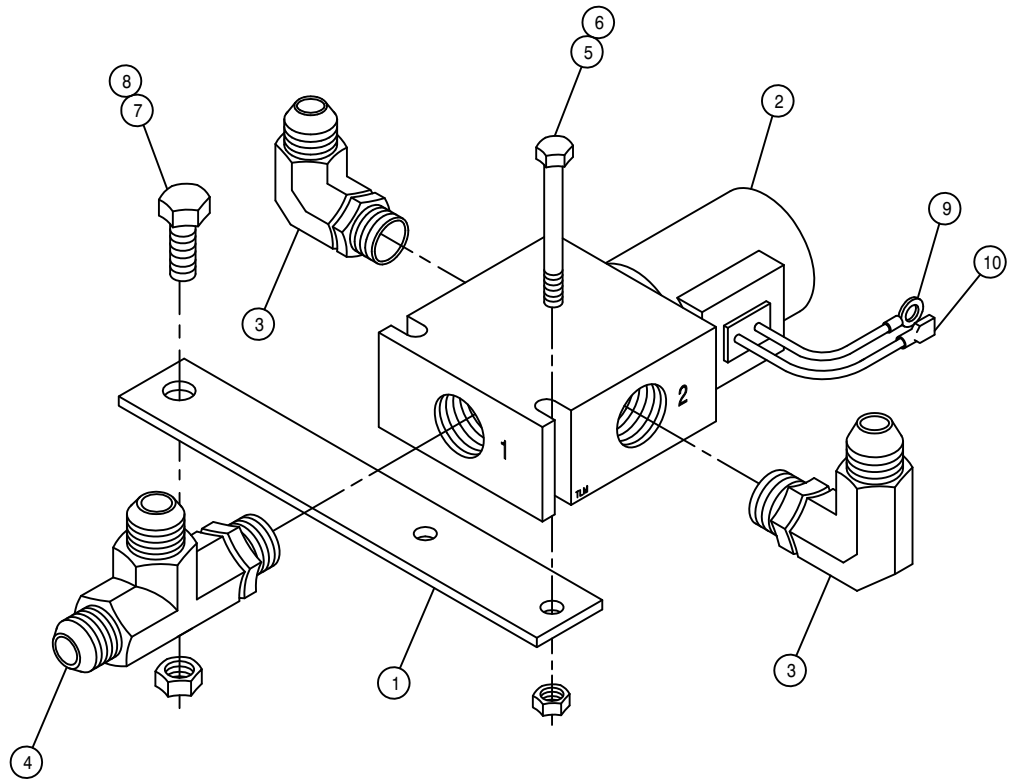

BRAKE SOLENOID ASSEMBLY

DET.	QTY	PART NO.	DESCRIPTION
1	1	342332	PARK BRAKE SOL VLV MT 97
2	1	610318	HYD SOLE VLV,2P-3W,9/16FOR,12V
3	2	618119	9/16MJIC-90-9/16MOR LBO
4	1	618444	9/16MOR RUN TEE-9/16MJIC
5	2	900006	1/4UNC X 1 3/4 HEX BOLT
6	2	914000	1/4UNC HEX STOVER NUT
7	1	900129	3/8UNC X 1" HEX BOLT
8	1	914004	3/8UNC HEX STOVER NUT
9	1	291590	.312RING TERM 14-16WIRE INS
10	1	293163	.250MALE FASTON14-16 FULL INS

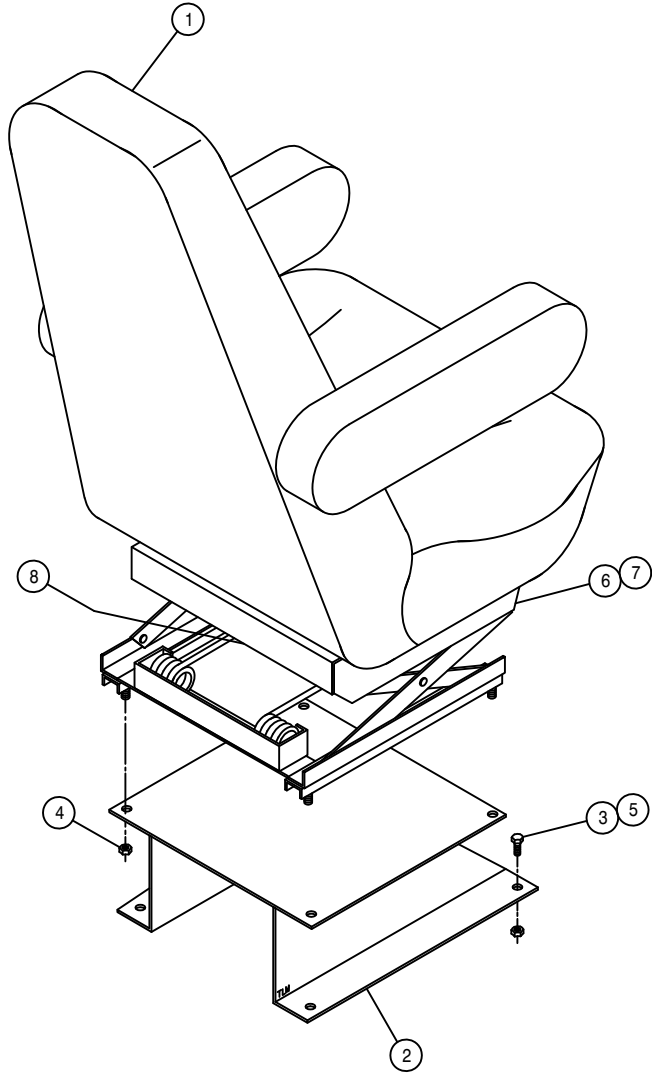

SEAT ASSEMBLY

DET. QTY PART NO. DESCRIPTION

1	1	330022	SEAT, MAGNUM-100 AIR SUSPEND95
2	1	342090	SEAT MT WELD, 254/284 95
3	4	900129	3/8UNC X 1" HEX BOLT
4	4	914002	5/16UNC HEX STOVER NUT
5	4	914004	3/8UNC HEX STOVER NUT
6	1	330024	HEIGHT ADJ LATCH, SEAT 330022
7	1	330025	ADJ LATCH SPRING, SEAT 330022
8	1	330023	AIR BAG PKG, SEAT 330022

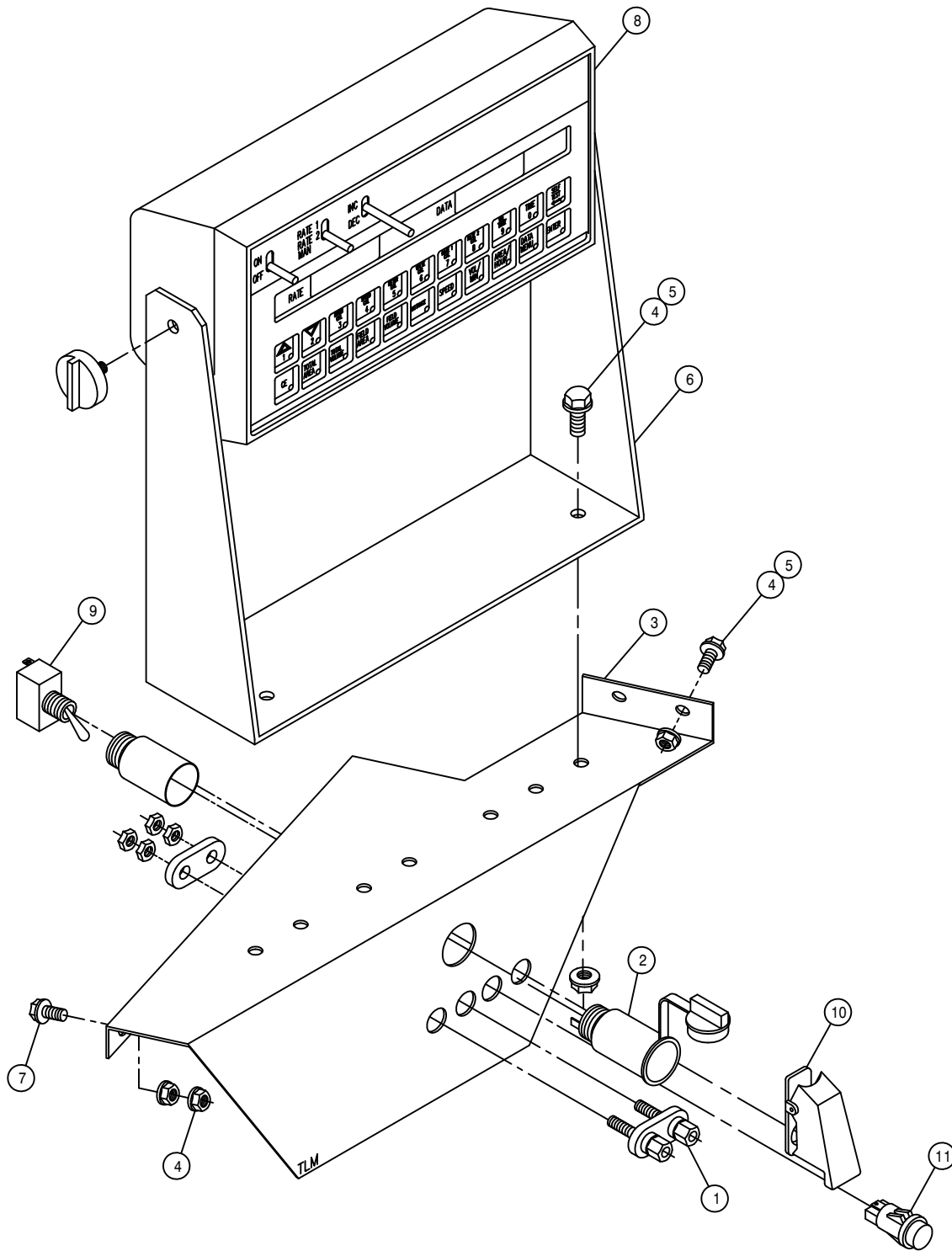

MONITOR MOUNTING BRACKET ASSEMBLY

DET. QTY PART NO. DESCRIPTION

1	1	291647	DUAL BINDING POSTS
2	1	291648	POWER POINT RECEPTACLE
3	1	343201	MONITOR MT, 284XP CAB 2001
4	7	470121	1/4UNC HEX FLANGE LOCK NUT
5	5	470122	1/4UNC X 1/2 FLANGE HEX BOLT
6	1	690498	CONSOLE MT, RAVEN 460 95
7	1	470118	1/4UNC X 3/4 FLANGE HEX BOLT
8	1	690618	CONSOLE, RAVEN 460 W/GPS PORT
9	1	298012	TOGGLE SWITCH, ON-OFF, SPST, 15A
10	1	291655	AIRCRAFT TOGGLE SWITCH GUARD
11	1	390318	INDICATOR LIGHT, RED



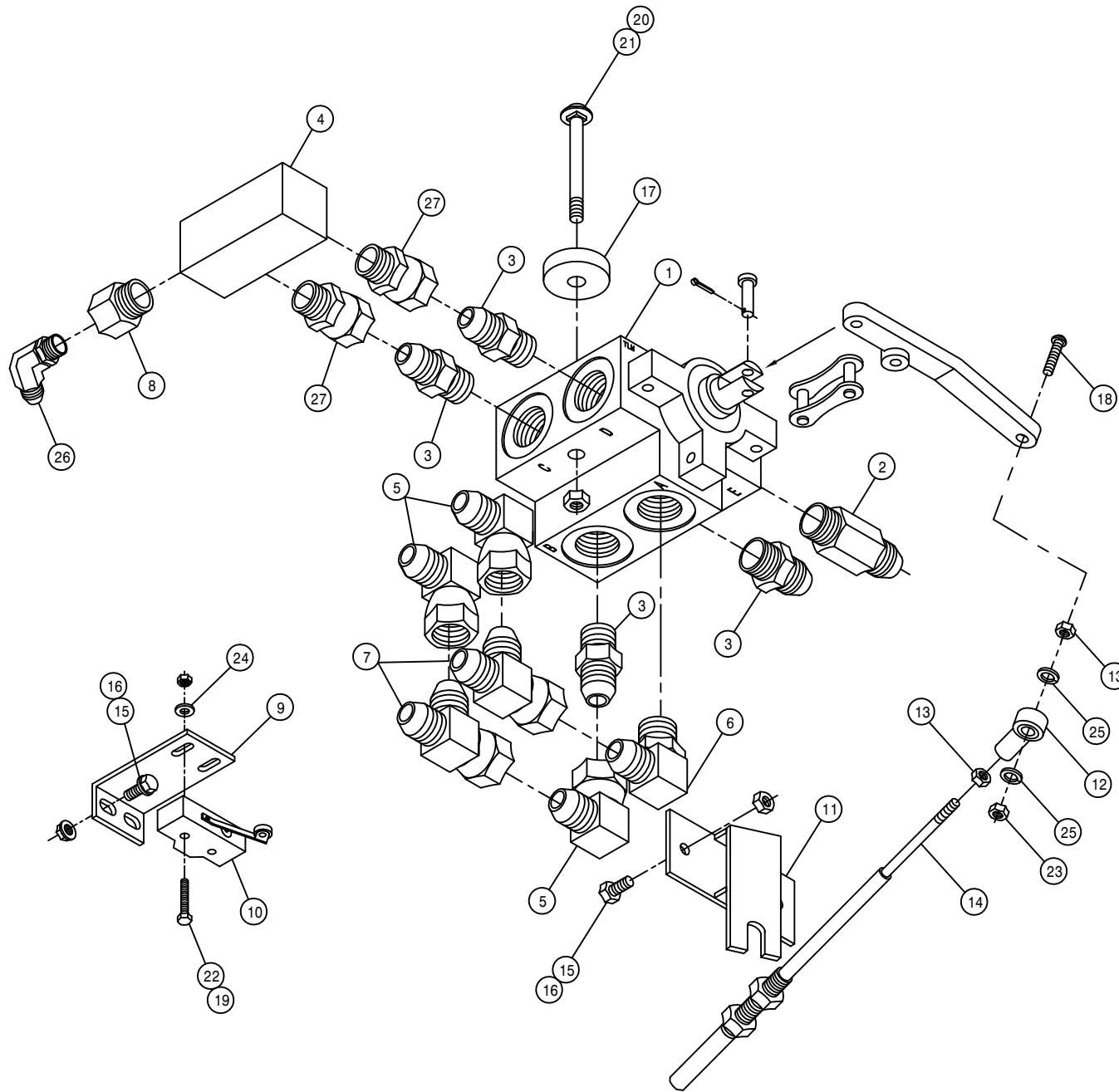

FOUR-WHEEL DRIVE SELECTOR VALVE ASSEMBLY

DET. QTY PART NO. DESCRIPTION

1	1	606003	GRESEN SELECTOR VALVE DS-12
2	1	607527	FLOW CTRL VALVE,32GPM IN-LINE
3	4	611127	1 1/16MJIC-1 1/16MOR ADPTR
4	1	606020	4WD SELECTOR VALVE MANIF 2002
5	3	618191	1 1/16MJ-90-1 1/16FJ SWIV LBO
6	1	618248	1 1/16MJIC-90-1 1/16MOR LBO
7	2	618487	1 1/16FJ SW RUN TEE-1 1/16MJ
8	1	618005	1 1/16MOR-9/16FOR ADPTR
9	1	291646	TRACT VLV MICRO SWITCH MT
10	1	293006	MICRO SWITCH, SPDT BZ-2RL-A2
11	1	341861	FWD CABLE MT WLD 280 89
12	1	473921	BALL JOINT NO 10-32 THD
13	2	910027	10-32 HEX NUT
14	1	785065	CTRL CABLE 10-32 4IN X 68 LG
15	4	470118	1/4UNC X 3/4 FLANGE HEX BOLT
16	4	470121	1/4UNC HEX FLANGE LOCK NUT
17	2	748501	RUBBER WASH .38 X .406 X 1.50
18	1	903893	10-32 X 1" SLT RD HD MACH SCR
19	2	910022	6-32 HEX NUT
20	2	914004	3/8UNC HEX STOVER NUT
21	2	901136	3/8UNC X 3" CARR BOLT
22	2	473993	6-32 X 1 1/4 HH MACH SCR
23	1	914027	10-32 HEX STOVER NUT
24	2	920011	# 6 SAE FLAT WASHER
25	2	920510	#10 LOCK WASHER
26	1	618425	9/16MJIC-45-9/16MOR LBO
27	2	618578	1 1/16FJIC SWIV-1 1/16MOR

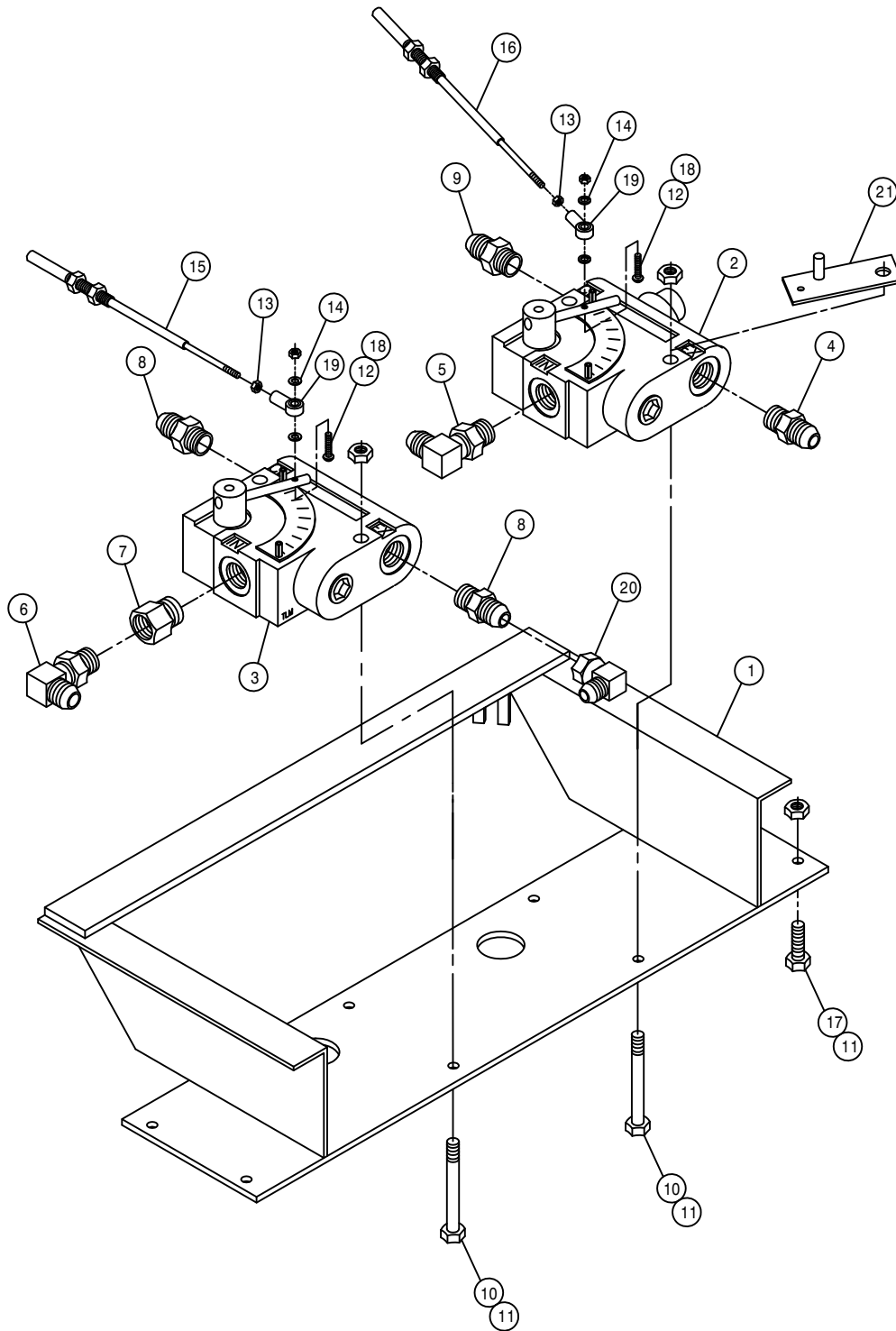

VARIABLE FLOW CONTROL ASSEMBLY

DET.	QTY	PART NO.	DESCRIPTION	
	1	342209	SOLU VFC MT WLD	94
	2	606818	FLO CONT FCR51 0-16GPM 7/8FOR	
	3	606827	FLO CONT FC51 0-3 VARI 7/8FOR	
	4	611126	7/8MJIC-7/8MOR ADPTR	
	5	611128	7/8MJIC-90-7/8MOR LBO	
	6	618119	9/16MJIC-90-9/16MOR LBO	
	7	618172	7/8MOR-9/16FOR ADPTR	
	8	618310	9/16MJIC-7/8MOR ADPTR	
	9	618327	3/4MJIC-7/8MOR ADPTR	
	10	900008	1/4UNC X 2 1/2 HEX BOLT	
	11	914000	1/4UNC HEX STOVER NUT	
	12	903893	10-32 X 1" SLT RD HD MACH SCR	
	13	910027	10-32 HEX NUT	
	14	920510	#10 LOCK WASHER	
	15	785064	CTRL CABLE 10-32 2IN X 53 LG	
	16	785063	CTRL CABLE 10-32 2IN X 42 LG	
	17	470118	1/4UNC X 3/4 FLANGE HEX BOLT	
	18	914027	10-32 HEX STOVER NUT	
	19	473921	BALL JOINT NO 10-32 THD	
	20	618618	9/16MJIC-90-9/16FJIC SWIV LBO	
	21	342306	SOLU PUMP VFC STOP WLD,9G	96

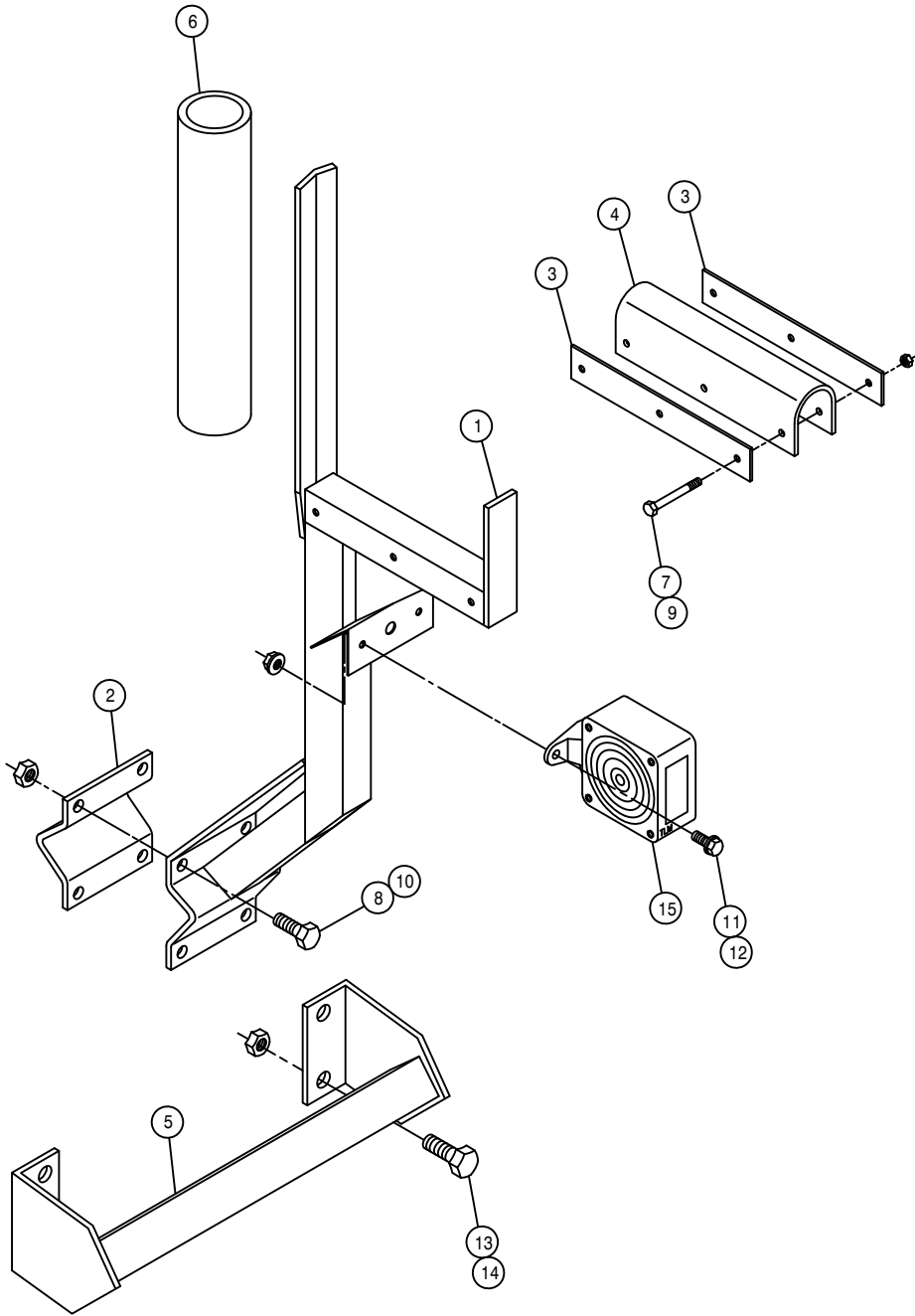

BOOM CRADLE ASSEMBLY

DET.	QTY	PART NO.	DESCRIPTION	
1	2	164245	BOOM CRADLE WLD	96
2	2	164253	BOOM CRADLE V-PLATE KEEPER	96
3	4	164254	CRADLE CUSHION KEEPER	96
4	2	164256	BOOM CRADLE CUSHION	96
5	2	164680	BOOM CRADLE MT WLD 284XP 2001	
6	2	601184	HOSE, 1 1/2 X 14 2BR BLK EPDM	
7	6	900008	1/4UNC X 2 1/2 HEX BOLT	
8	8	900265	1/2UNC X 1 1/2 HEX BOLT	
9	6	914000	1/4UNC HEX STOVER NUT	
10	8	914008	1/2UNC HEX STOVER NUT	
11	4	470121	1/4UNC HEX FLANGE LOCK NUT	
12	4	470118	1/4UNC X 3/4 FLANGE HEX BOLT	
13	8	900334	5/8UNC X 1 3/4 HEX BOLT	
14	8	914010	5/8UNC HEX STOVER NUT	
15	2	291604	TURN SIGNAL LIGHT,PED MT, YEL	

NOTE: QUANTITY LISTED IS FOR ONE MACHINE.

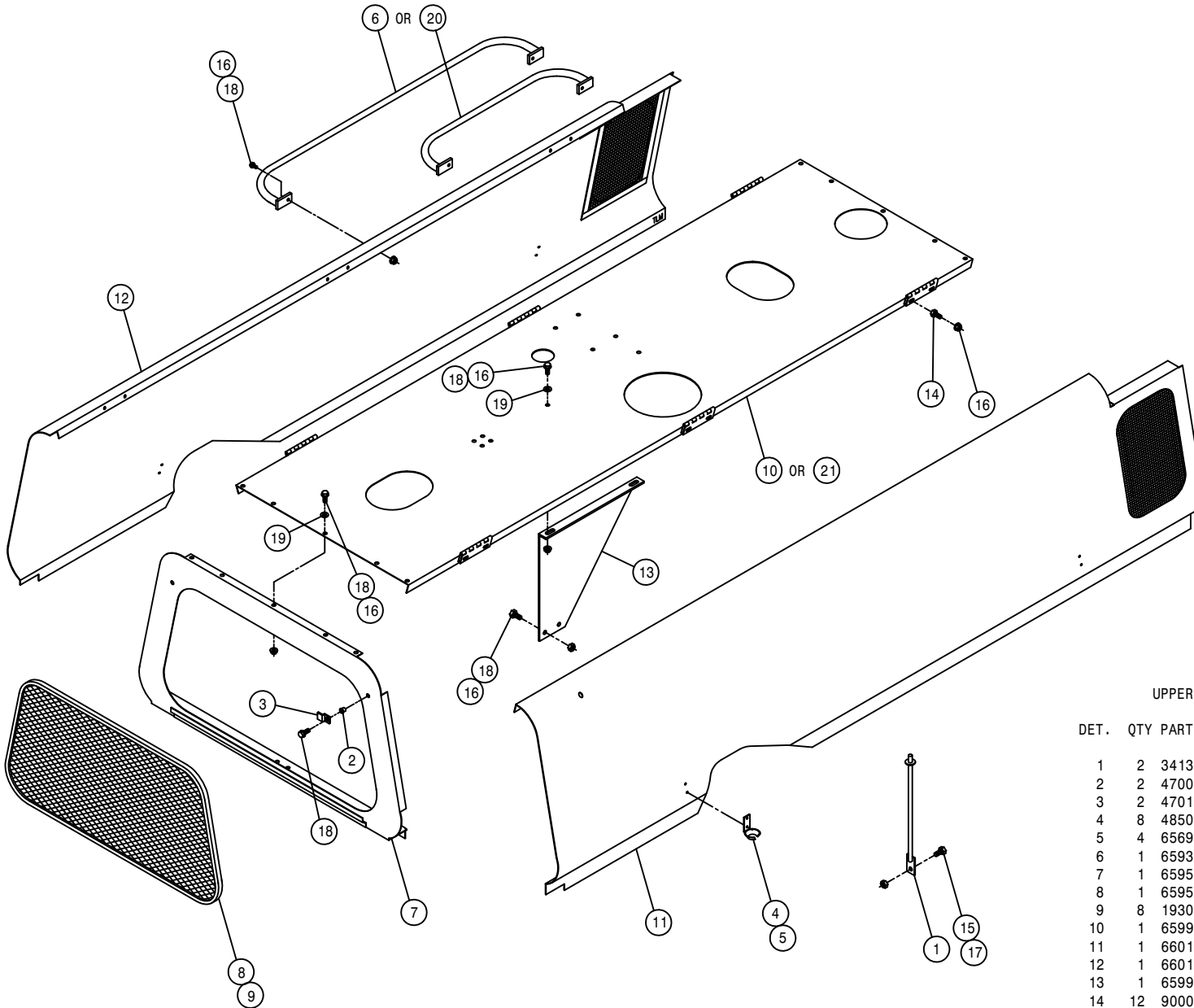

UPPER SHEET METAL ASSEMBLY

DET.	QTY	PART NO.	DESCRIPTION
	1	2	341356 ENGINE HOOD PROP WLD 8240 82
	2	2	470086 1/4UNC NUTSERT .020-.100MATL
	3	2	470151 UPPER REAR PANEL SCREEN CLIP
	4	8	485053 POP RIVET 3/16 X 3/8
	5	4	656997 RUBBER HOOK BRKT
	6	1	659378 RH ENG HOOD HANDRAIL WLD 647S
	7	1	659575 UPPER REAR PANEL WLD 8240 82
	8	1	659578 UPPER REAR PANEL SCREEN 8240
	9	8	193016 QUICKEDGE TRIM .060 TO .170
	10	1	659931 MULLION WLD, 204 CUMM 97
	11	1	660191 RH ENG HOOD WLD 284XP 2001
	12	1	660192 LH ENG HOOD WLD 284XP 2001
	13	1	659930 MULLION SUPPORT BRKT, 284 97
	14	12	900000 1/4UNC X 1/2 HEX BOLT
	15	2	900128 3/8UNC X 3/4 HEX BOLT
	16	28	470121 1/4UNC HEX FLANGE LOCK NUT
	17	2	914004 3/8UNC HEX STOVER NUT
	18	18	470118 1/4UNC X 3/4 FLANGE HEX BOLT
	19	12	470212 1/4 BONDED SEALING WASH, SS
	20	1	660236 ENG HOOD HANDRAIL WLD, 2XX 04
	21	1	660234 MULLION WLD, 204/284 CUMM 04

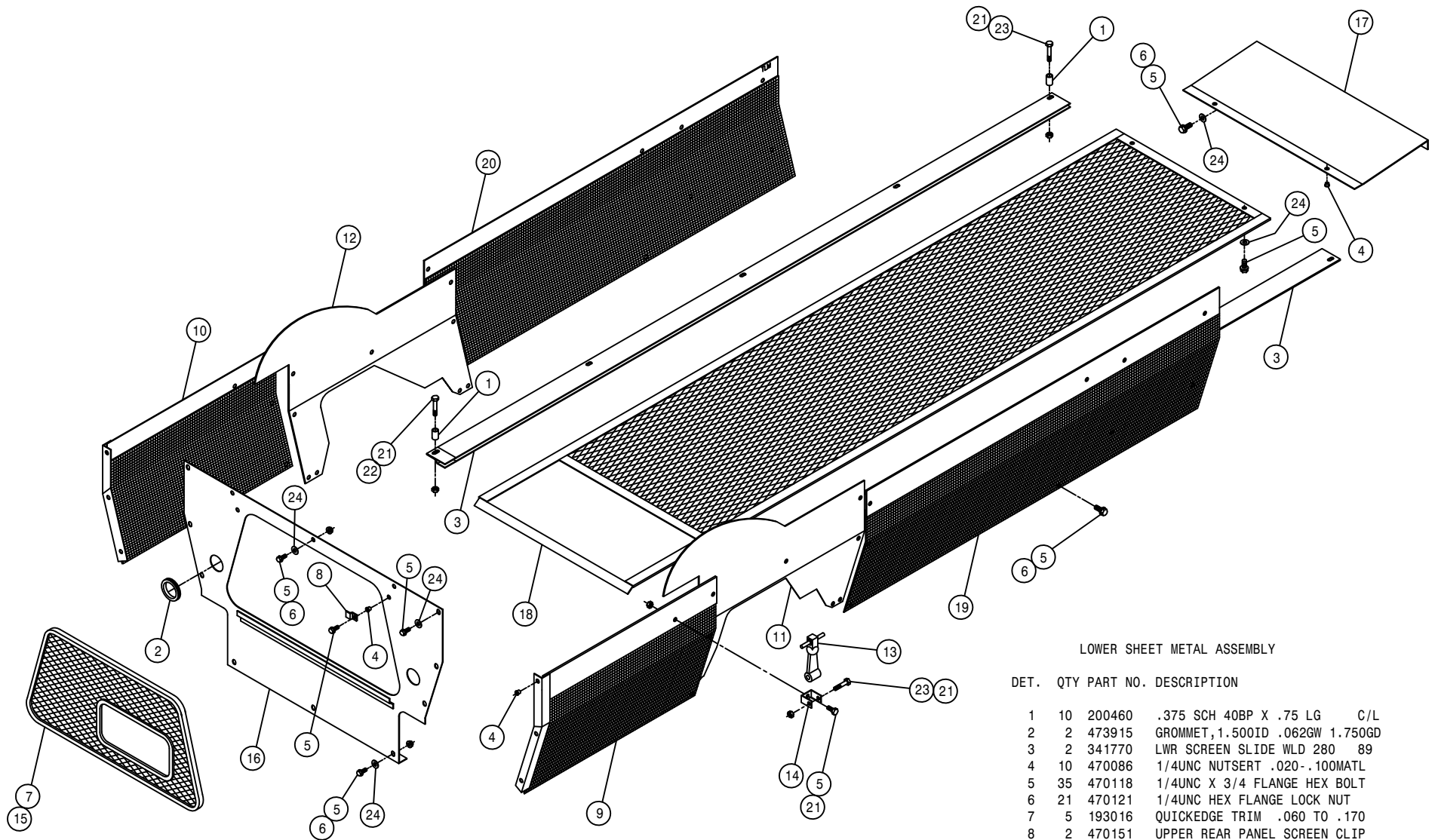

LOWER SHEET METAL ASSEMBLY

DET.	QTY	PART NO.	DESCRIPTION
1	10	200460	.375 SCH 40BP X .75 LG C/L
2	2	473915	GROMMET, 1.500ID .062GW 1.750GD
3	2	341770	LWR SCREEN SLIDE WLD 280 89
4	10	470086	1/4UNC NUTSERT .020-.100MATL
5	35	470118	1/4UNC X 3/4 FLANGE HEX BOLT
6	21	470121	1/4UNC HEX FLANGE LOCK NUT
7	5	193016	QUICKEDGE TRIM .060 TO .170
8	2	470151	UPPER REAR PANEL SCREEN CLIP
9	1	659889	RH REAR SIDE SCR N WLD 2XX 92
10	1	659890	LH REAR SIDE SCR N WLD 2XX 92
11	1	660195	RH LWR SIDE SHIELD, 284XP 2001
12	1	660196	LH LWR SIDE SHIELD, 284XP 2001
13	4	656998	RUBBER HOOK
14	4	656999	RUBBER HOOK ANCHOR BRKT
15	1	659929	LWR BACK PANEL SCR N, 284 98
16	1	660197	LWR REAR PANEL WLD 284XP 2001
17	1	659803	LWR FRT SHIELD 280 89
18	1	659804	LWR SCREEN WLD 280 89
19	1	659906	RH FRT SIDE SCR N WLD, 284 94
20	1	659907	LH FRT SIDE SCR N WLD, 284 94
21	18	914000	1/4UNC HEX STOVER NUT
22	4	900006	1/4UNC X 1 3/4 HEX BOLT
23	10	900005	1/4UNC X 1 1/2 HEX BOLT
24	29	470212	1/4 BONDED SEALING WASH, SS

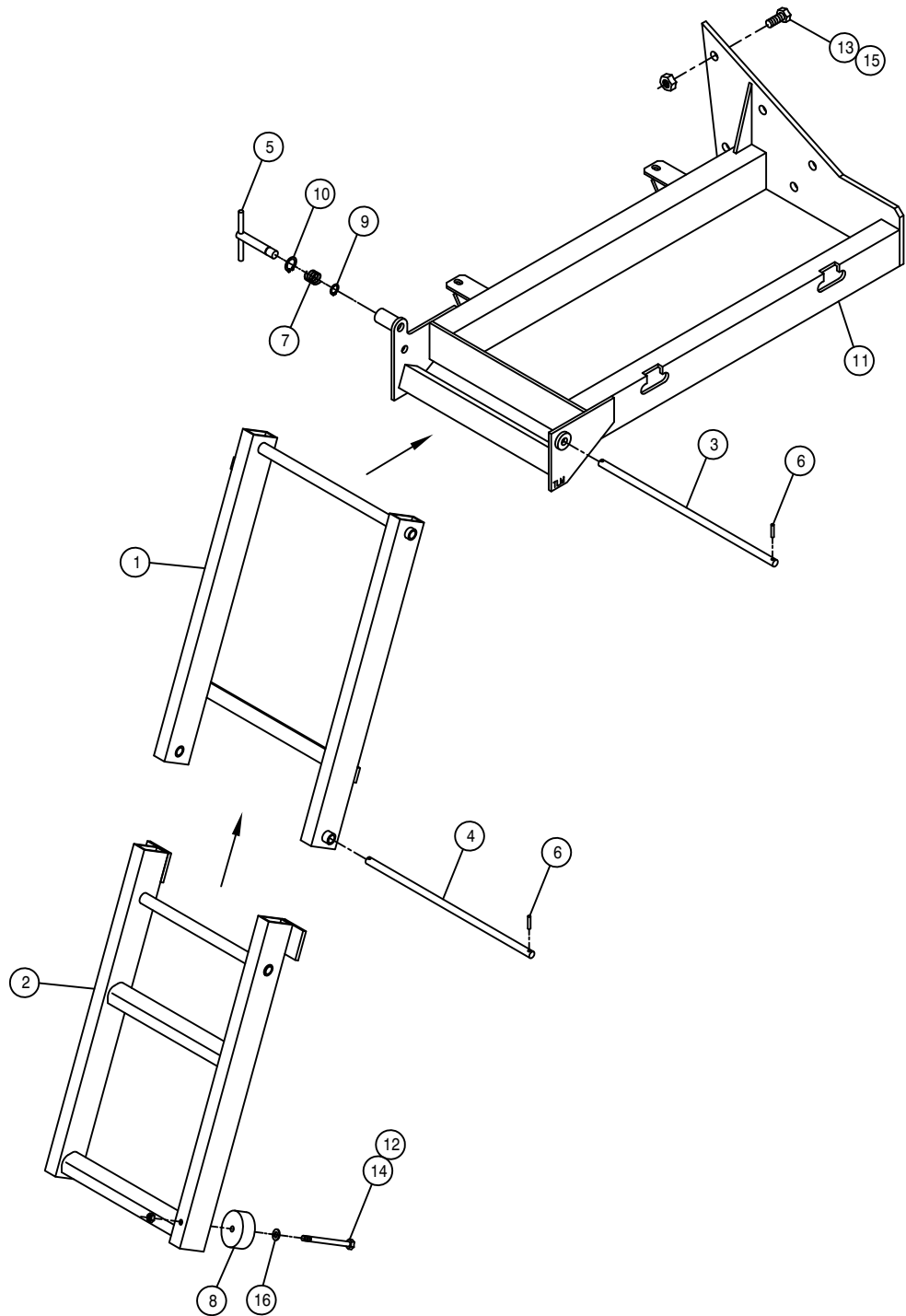

RIGHT FOLDING LADDER ASSEMBLY

DET. QTY PART NO. DESCRIPTION

1	1	342583	FOLD LDDR UPR SECT WLD,2100 98
2	1	342589	FOLD LDDR LWR SECT WLD,2100 98
3	1	342594	FOLD LADDER UPR PIVOT PIN 98
4	1	342595	FOLD LADDER LWR PIVOT PIN 98
5	1	342596	FOLD LDDR LOCK PIN WLD,2100 98
6	4	473928	ROLL PIN, 3/16 X 1
7	1	482131	3/4 X 1 3/4 COMPRSN SPRING
8	1	470098	RUBBER BUMPER 2.500D X .38ID
9	1	629534	SNAP RING, 9/16 EXTERNAL
10	1	629535	SNAP RING, 3/4 INTERNAL
11	1	760215	RH FUEL TANK MT WLD, 2100 98
12	1	900072	5/16UNC X 3" HEX BOLT
13	6	900334	5/8UNC X 1 3/4 HEX BOLT
14	1	910002	5/16UNC HEX NUT
15	6	914010	5/8UNC HEX STOVER NUT
16	1	920001	5/16 SAE FLAT WASHER

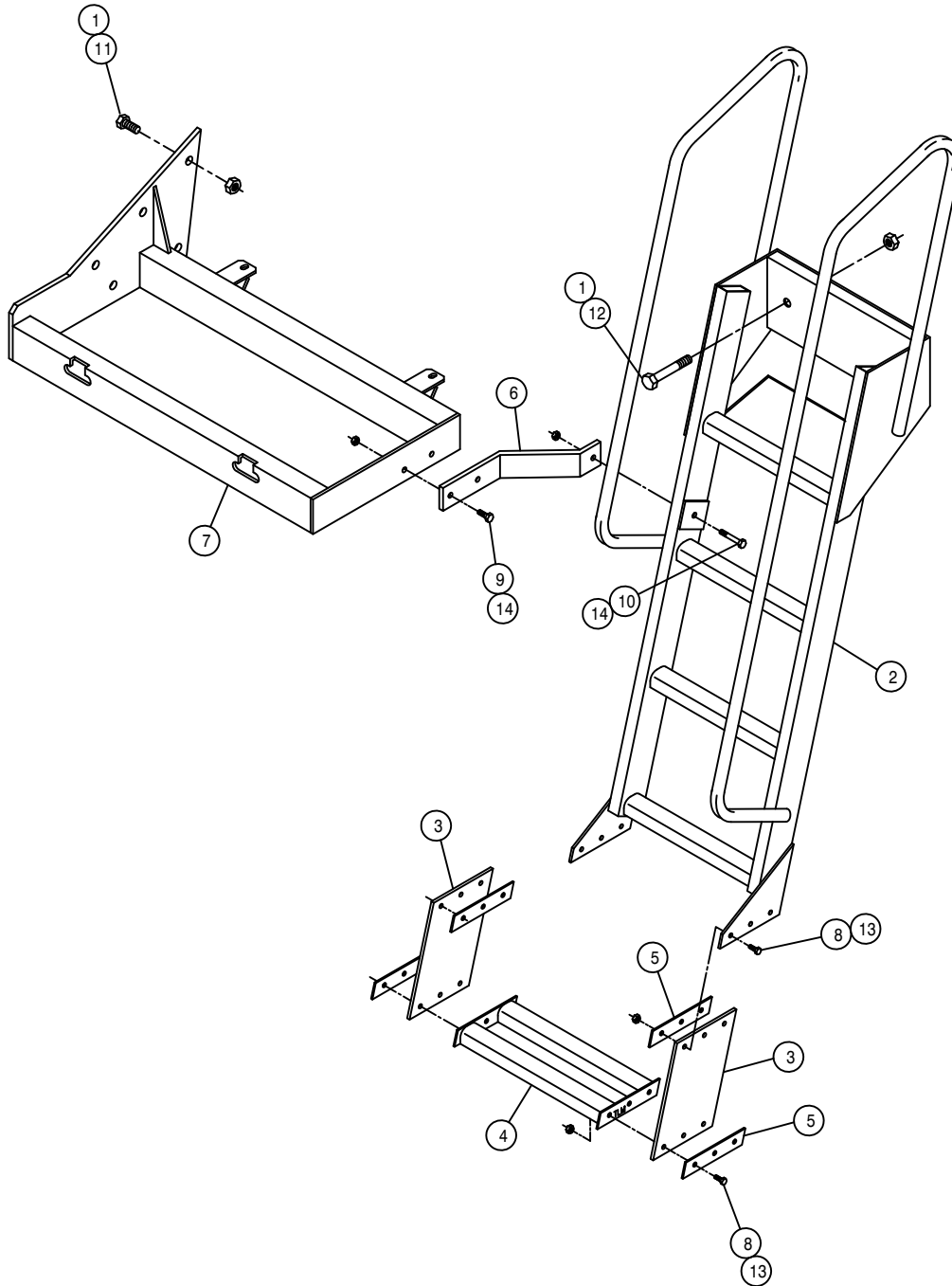

LEFT LADDER ASSEMBLY

DET. QTY PART NO. DESCRIPTION

1	8	914010	5/8UNC HEX STOVER NUT	
2	1	342605	LH LADDER WLD, 2100	98
3	2	342614	LADDER SIDE, LWR STEP, 2100	98
4	1	342615	LADDER STEP WLD, 2100	98
5	4	342616	LWR STEP SIDE KEEPER, 2100	98
6	1	342892	LH LADDER BRACE 284XP	2001
7	1	760216	LH FUEL TANK MT WLD, 2100	98
8	12	900065	5/16UNC X 1" HEX BOLT	
9	2	900130	3/8UNC X 1 1/4 HEX BOLT	
10	1	900133	3/8UNC X 2" HEX BOLT	
11	6	900334	5/8UNC X 1 3/4 HEX BOLT	
12	2	900829	5/8UNC X 4" HEX BOLT GR8	
13	12	914002	5/16UNC HEX STOVER NUT	
14	3	914004	3/8UNC HEX STOVER NUT	

FUEL TANK ASSEMBLY

DET. QTY PART NO. DESCRIPTION

1	2	291428	FUEL SENDER 19 IN.	
2	10	473902	NO 8 X 1/2 PAN HD MET SC	
3	2	501102	1/4 PIPE PLUG	
4	8	501451	BLK PIPE EL 90DEG .25NPT	
5	4	501602	BLK PIPE NIPPLE .25NPT-1.50	
6	2	760179	FUEL TANK WLD, 2100	98
7	2	761200	GAS CAP	
8	2	783303	1/4 NPT X 5/16 HOSE BARB, BRS	
9	2	783304	1/4 NPT X 3/8 HOSE BARB, BRS	
10	4	760184	FUEL TANK BAND WLD, 2100	98
11	4	914004	3/8UNC HEX STOVER NUT	
12	14	520120	HOSE CLAMP NO 4 STAINLESS	
13	1	601421	HOSE, 5/16 X 90 FUEL LINE	
14	2	601324	HOSE, 3/8 X 90 FUEL LINE	
15	2	601545	HOSE, 5/16 X 108 FUEL LINE	
16	2	316281	FUEL STRAINER, IN-LINE, DIESEL	
17	2	601528	HOSE, 3/8 X 9 FUEL LINE	
18	1	601322	HOSE, 3/8 X 26 FUEL LINE	
19	1	610529	FUEL SELECTOR VALVE W/RETURN	
20	1	610530	5 WIRE CONNECTOR FOR 610529	
21	2	900064	5/16UNC X 3/4 HEX BOLT	

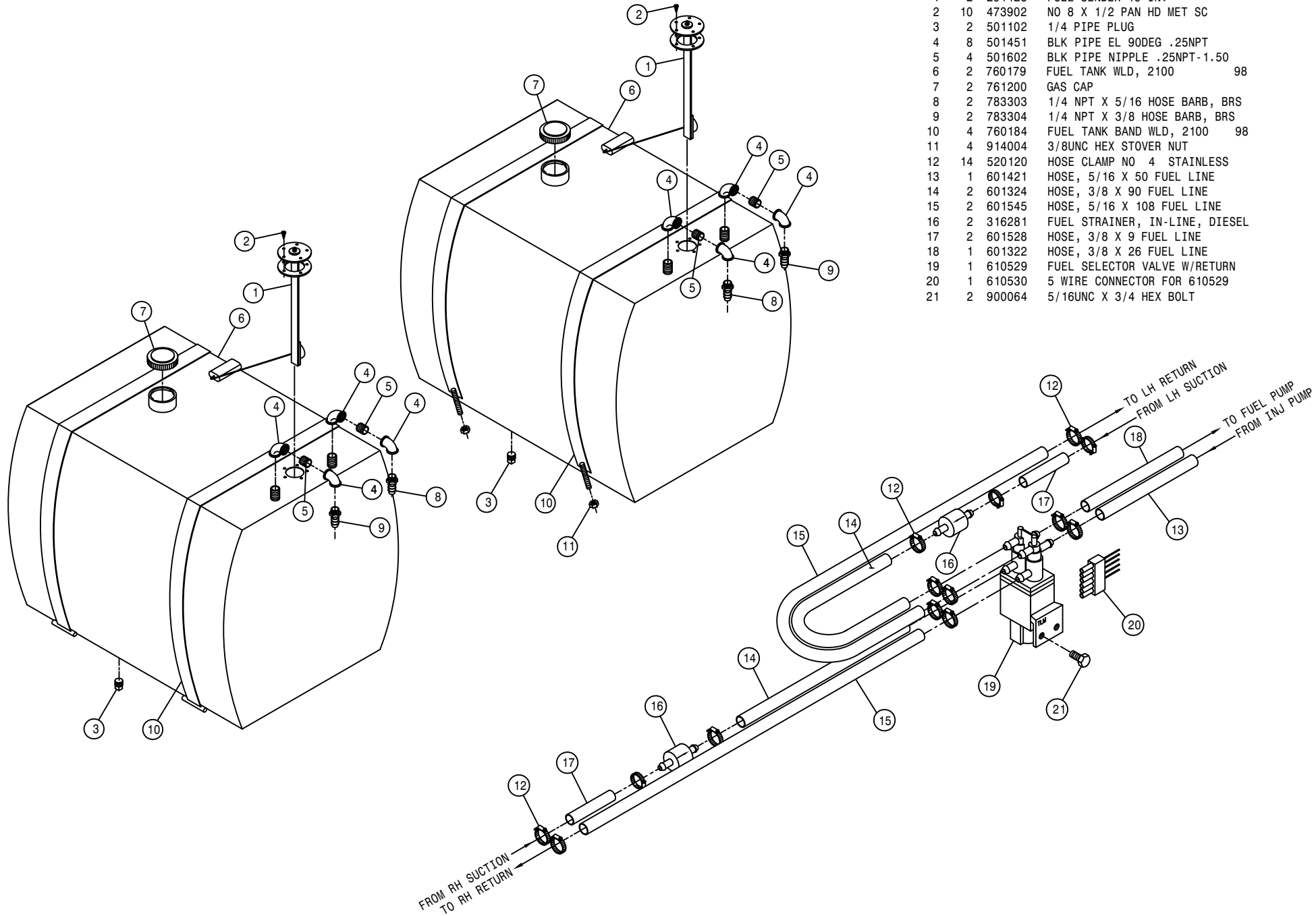



SERVICE PLATFORM ASSEMBLY

DET. QTY PART NO. DESCRIPTION

1	2	291694	RED LAMP, 6 1/2" OVAL 12.8V
2	2	291697	RUBBER MT FOR 6 1/2" OVAL LAMP
3	2	293515	3-WIRE PIGTAIL ASSY
4	1	342860	REAR PLATFORM WLD, 284XP 01
5	1	342872	RH SERV PLATFORM WLD,284XP 01
6	1	342873	LH SERV PLATFORM WLD,284XP 01
7	1	342875	RH FRT SERV PLTFRM MT WLD XP
8	1	342876	LH FRT SERV PLTFRM MT WLD XP
9	1	342879	RH REAR SERV PLTFRM WLD XP 01
10	1	342880	LH REAR SERV PLTFRM WLD XP 01
11	1	342893	RH PLTFRM HANDRAIL WLD 284XP
12	1	342896	LH FRT PLTFRM HANDRAIL WLD XP
13	1	342900	LH REAR PLTFRM HANDRAIL WLD XP
14	1	472251	MTG SOCKET
15	1	472249	SLOW MOVING VEHICLE SIGN
16	1	472250	SPADE MTG BRKT
17	2	470118	1/4UNC X 3/4 FLANGE HEX BOLT
18	2	470121	1/4UNC HEX FLANGE LOCK NUT
19	8	900065	5/16UNC X 1" HEX BOLT
20	4	900071	5/16UNC X 2 3/4 HEX BOLT
21	4	900129	3/8UNC X 1" HEX BOLT
22	6	900334	5/8UNC X 1 3/4 HEX BOLT
23	4	900340	5/8UNC X 3 1/2 HEX BOLT
24	12	914002	5/16UNC HEX STOVER NUT
25	4	914004	3/8UNC HEX STOVER NUT
26	10	914010	5/8UNC HEX STOVER NUT
27	2	920006	3/4 SAE FLAT WASHER
28	2	470162	COTTER PIN 3/16 X 1 1/2 SQCUT

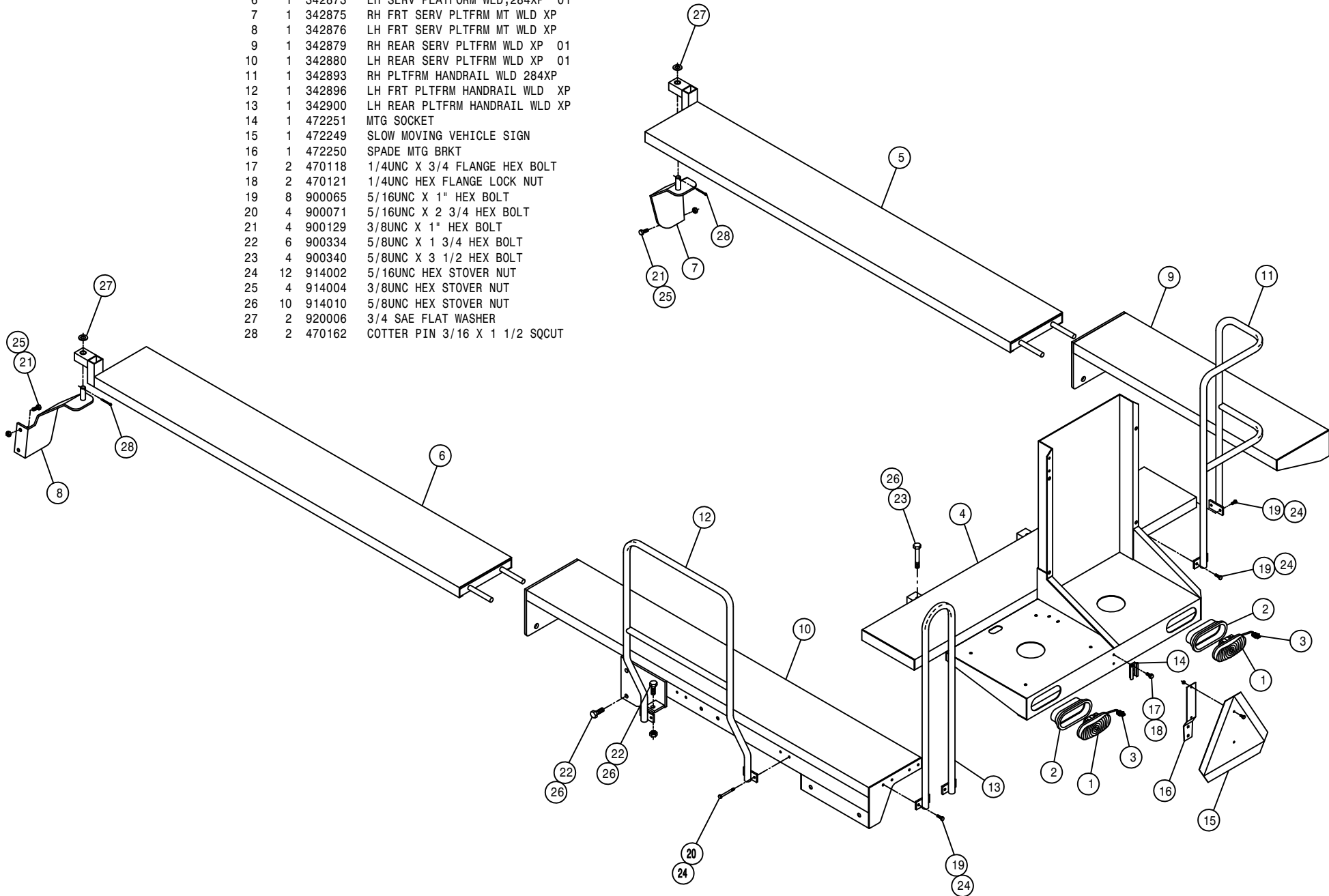

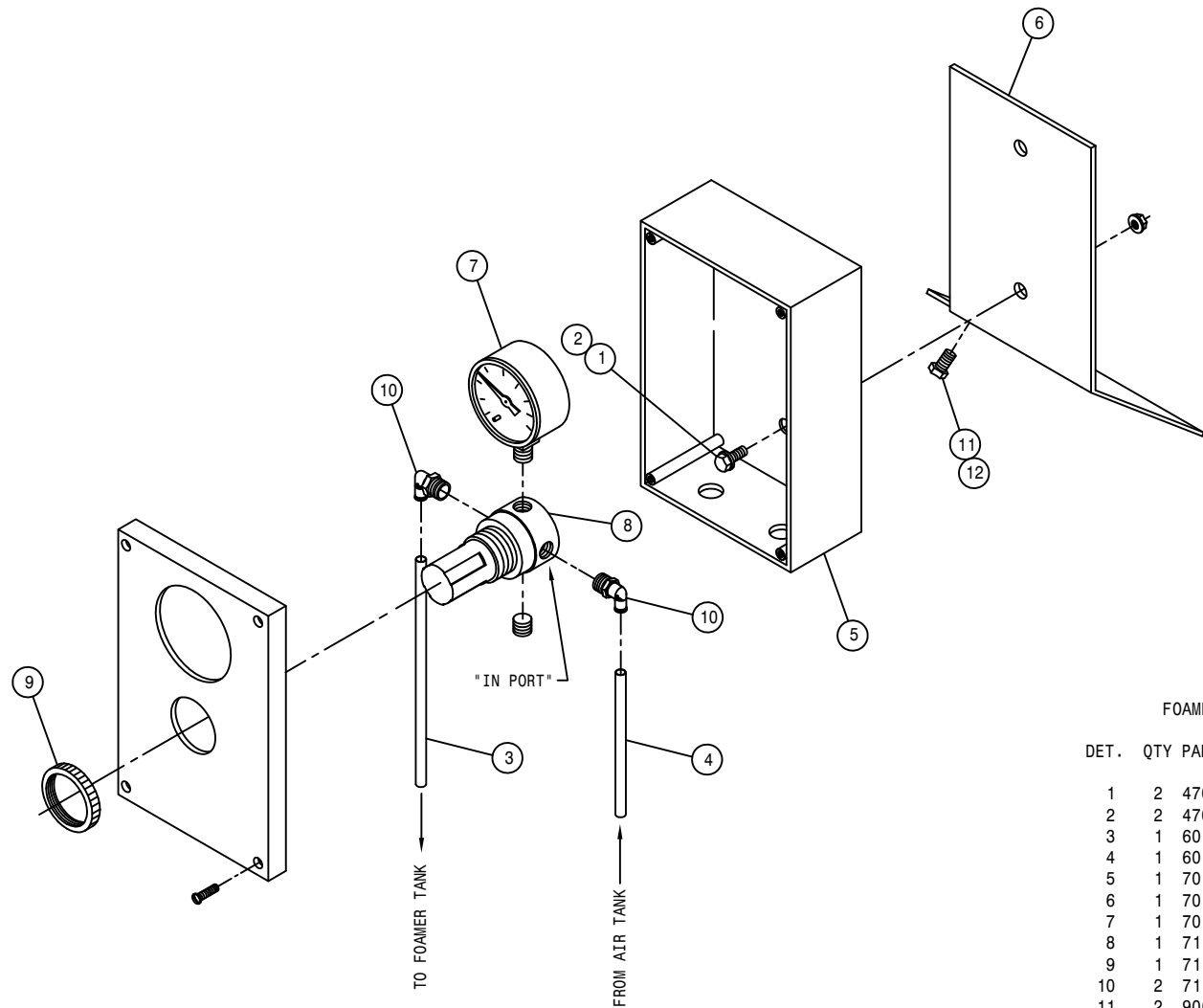

FOAMER AIR REGULATOR ASSEMBLY

DET.	QTY	PART NO.	DESCRIPTION
	1	2 470113	5/16UNC HEX FLANGE LOCK NUT
	2	2 470232	5/16UNC X 1/2 FLANGE HEX BOLT
	3	1 601394	HOSE, 1/4 X 34 AIR
	4	1 601476	HOSE, 1/4 X 120 AIR
	5	1 701184	FOAMER AIR REG MT BOX, STS12
	6	1 701205	FOAMER AIR REG MT BOX MT,284XP
	7	1 701310	AIR PRESS GAUGE, 1/8"BOT
	8	1 711019	1/4"MNPT AIR REGULATOR
	9	1 711021	1 1/4-18 NUT,AIR REGULATOR MT
	10	2 711040	1/4MNPT-90-1/4 NYL TUBE LBO
	11	2 900064	5/16UNC X 3/4 HEX BOLT
	12	2 914002	5/16UNC HEX STOVER NUT

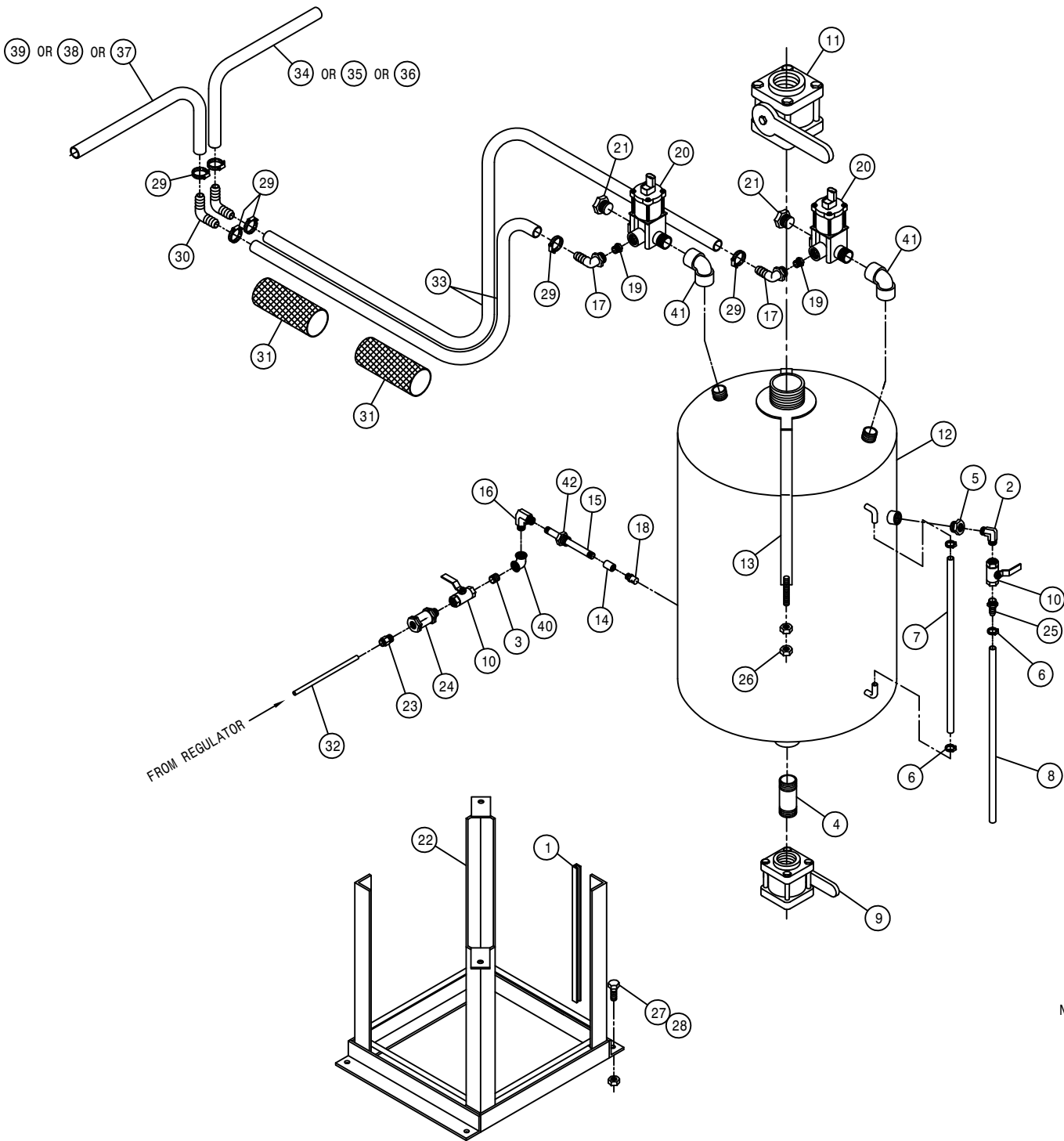

FOAM MARKER TANK ASSEMBLY

DET.	QTY	PART NO.	DESCRIPTION
1	8	193016	QUICKEDGE TRIM .060 TO .170
2	1	502705	1/4NPT-90-1/4NPT LBO, BRS
3	1	501601	CLOSE NIPPLE .25NPT
4	1	505203	BLK PIPE NIPPLE 1.00NPT-4.00
5	1	505211	3/8-1/4NPT REDU BUSH, BRS
6	3	520120	HOSE CLAMP NO 4 STAINLESS
7	1	601364	HOSE, 3/8 X 16 CLEAR VINYL
8	1	601370	HOSE, 3/8 X 30 CLEAR VINYL
9	1	695900	BALL VALVE 1IN FNPT POLY
10	2	696120	BALL VALVE, 1/4NPT, STEEL
11	1	696134	BALL VALVE 2IN FNPT POLY
12	1	701091	FOAM MARKER TANK, 20 GAL SS
13	1	701099	FOAM MARKER TANK STRAP WLD
14	1	500223	SS PIPE CPLG, 1/8NPT
15	1	507021	SS PIPE NIPPLE, 1/8NPT X 6"
16	1	701143	FOAMER AIR TUBE FTG
17	2	701214	1/2NPT-90-3/4HBARB, 1/4TAP, POLY
18	1	701144	FOAMER AIR NOZZLE
19	2	701215	1/4PIPE PLUG, .187 ORIFICE, POLY
20	2	696181	3/4" ELECT SOLU SOLE VALVE 02
21	2	500043	3/4NPT PIPE PLUG, POLY
22	1	701201	FOAM MARKER TANK MT WLD 284XP
23	1	711049	1/4 NYL TUBE-1/4MNPT FTG
24	1	711052	1/4"NPT CHECK VALVE, SWING, 2600
25	1	783304	1/4 NPT X 3/8 HOSE BARB, BRS
26	4	910004	3/8UNC HEX NUT
27	4	900129	3/8UNC X 1" HEX BOLT
28	4	914004	3/8UNC HEX STOVER NUT
29	6	520055	HOSE CLAMP NO 12 STAINLESS
30	2	500069	3/4-90-3/4 HOSE BARB, POLY
31	2	342333	NYL HOSE SLEEVE, 2.64ID X 12.00
32	1	601394	HOSE, 1/4 X 34 AIR
33	2	195908	HOSE, 3/4ID-1/8W CLEAR VINYL X 240.00
34	1	195908	HOSE, 3/4ID-1/8W CLEAR VINYL X 612.00
35	1	195908	HOSE, 3/4ID-1/8W CLEAR VINYL X 732.00
36	1	195908	HOSE, 3/4ID-1/8W CLEAR VINYL X 792.00
37	1	195908	HOSE, 3/4ID-1/8W CLEAR VINYL X 588.00
38	1	195908	HOSE, 3/4ID-1/8W CLEAR VINYL X 708.00
39	1	195908	HOSE, 3/4ID-1/8W CLEAR VINYL X 768.00
40	1	501451	BLK PIPE EL 90DEG .25NPT
41	2	500079	3/4NPT-90 EL, POLY
42	1	507728	REDU BUSH 1/2MNPT X 1/4FNPT, SS

NOTE: 1. DETAIL 34 AND 37 ARE USED WITH THE 60 FT BOOM.  
 2. DETAIL 35 AND 38 ARE USED WITH THE 80 FT BOOM.  
 3. DETAIL 36 AND 39 ARE USED WITH THE 90 FT BOOM.

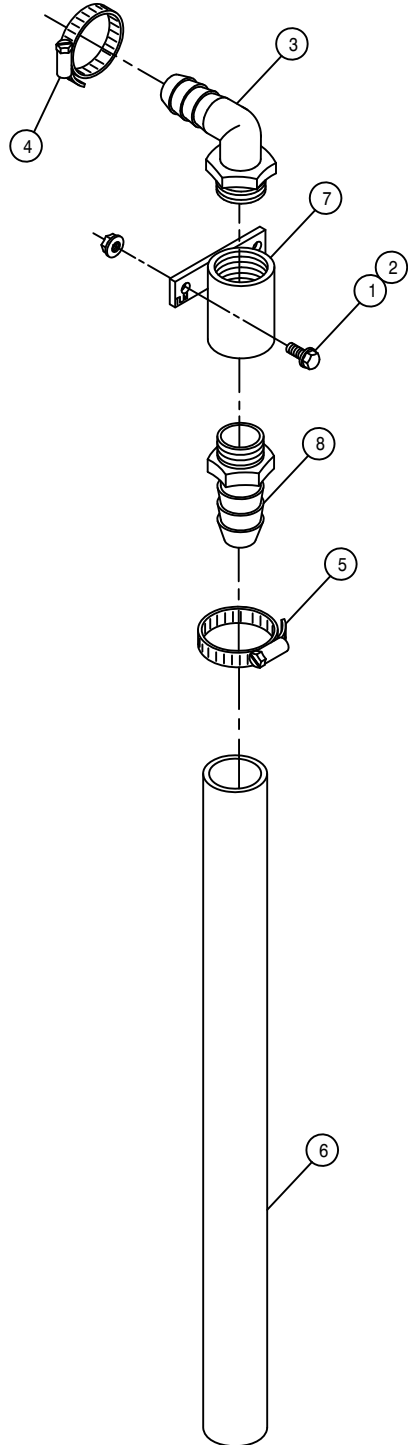

FOAMER DROP END ASSEMBLY

DET.	QTY	PART NO.	DESCRIPTION
1	4	470118	1/4UNC X 3/4 FLANGE HEX BOLT
2	4	470121	1/4UNC HEX FLANGE LOCK NUT
3	2	500067	1 NPT-90-3/4 HOSE BARB, POLY
4	2	520055	HOSE CLAMP NO 12 STAINLESS
5	2	520085	HOSE CLAMP NO 24 STAINLESS
6	2	601367	HOSE, 1 1/4 X 24 2BR BLK EPDM
7	2	701102	FOAM MARKER DROP CPLR WELD
8	2	714561	1.00NPT-1.25 HOSE BARB

NOTE: QUANTITY LISTED IS FOR ONE MACHINE.

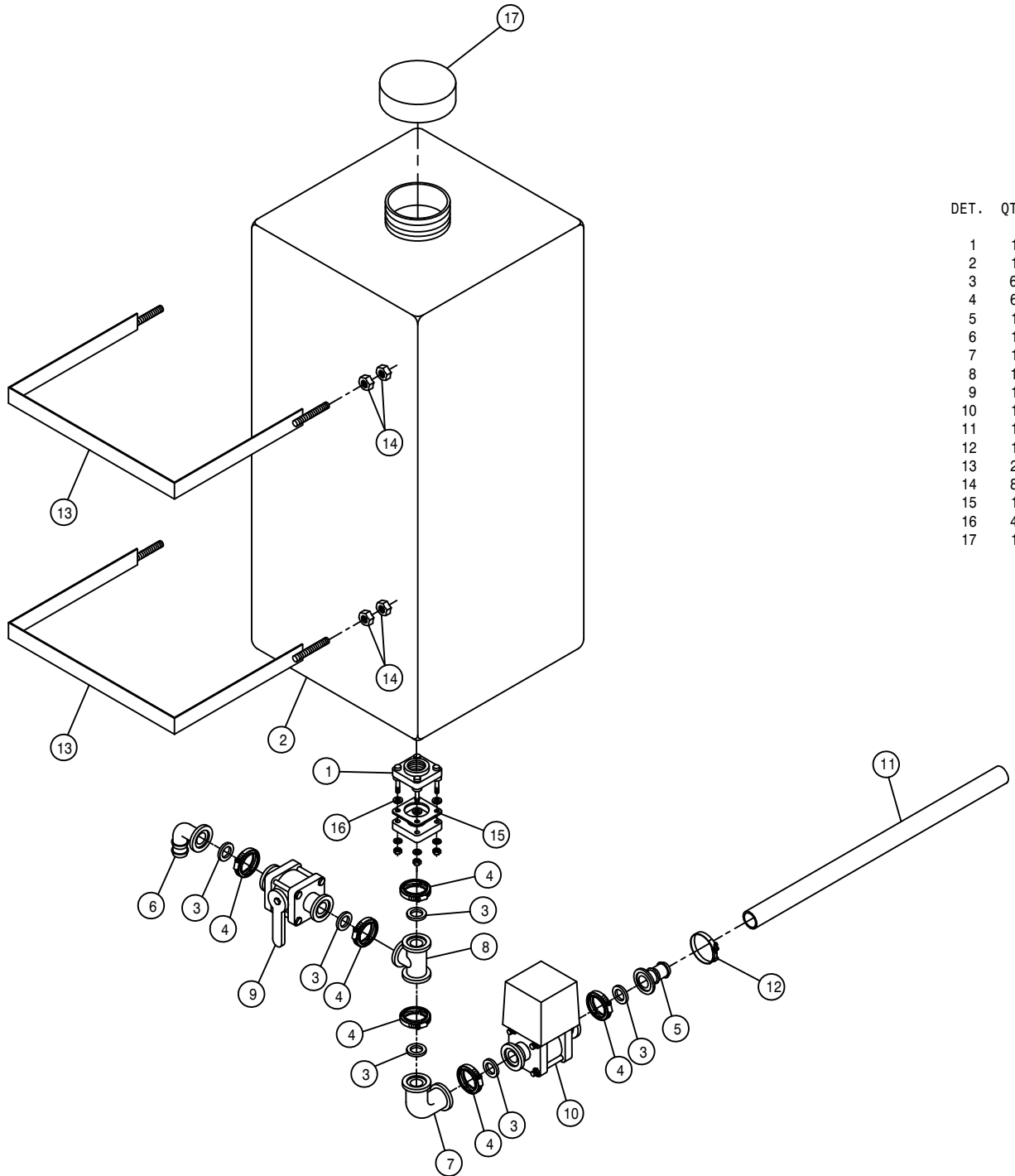

RINSE TANK ASSEMBLY

DET.	QTY	PART NO.	DESCRIPTION
1	1	500178	1"FLG TANK FTG,BOTDRN BLT POLY
2	1	763475	55 GAL TANK, RECTANGLE VERTICL
3	6	500157	1" FLANGE GASKET EPDM
4	6	500159	1" FLANGE CLAMP, S.S.
5	1	500171	1" FLANGE-1" HOSE BARB POLY
6	1	500173	1" FLANGE-90-1" HOSE BARB POLY
7	1	500174	1" FLANGE-90-1" FLANGE LBOPOLY
8	1	500175	1" FLANGE TEE POLY
9	1	696147	BALL VLV, 1" FLANGE
10	1	696177	ELECT BALL VLV,1"FLANGE TJET
11	1	601530	HOSE, 1 X 182 2F-1W EPDM
12	1	520138	1.38/1.56 T-BOLT HOSE CLAMP
13	2	342621	RINSE TANK BAND WLD, 2100 98
14	8	910008	1/2UNC HEX NUT
15	1	500221	FULL GASKET,1" TANK FTG 500178
16	4	500222	FOOT GASKET,1" TANK FTG 500178
17	1	763474	LID, 55 GAL RINSE TANK 763475

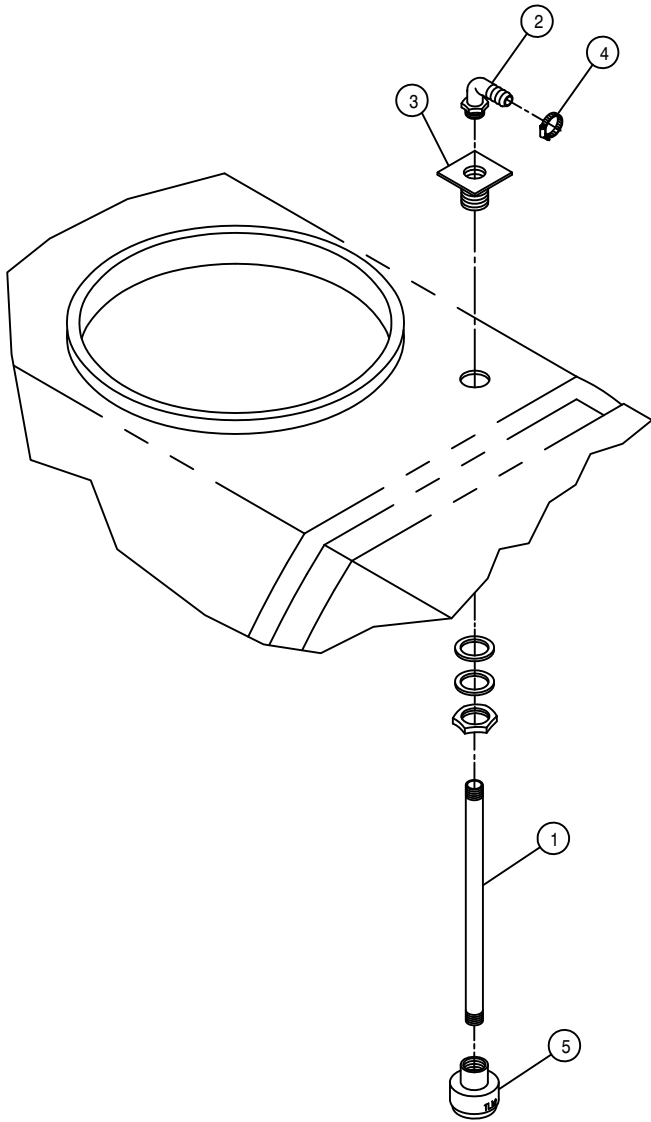

RINSE NOZZLE ASSEMBLY

DET. QTY PART NO. DESCRIPTION

1	1	504850	CPVC PIPE NIPPLE .75NPT-24.00
2	2	500041	3/4NPT-90-1/2"HOSE BARB, POLY
3	2	618549	.75 PLASTIC FTG ASSY POLY TNK
4	2	520070	HOSE CLAMP NO 8 STAINLESS
5	2	737873	ROTARY NOZZLE, TEFLON

NOTE: QUANTITY LISTED IS FOR ONE MACHINE.

SOLUTION TANK MOUNTS AND SHIELDS

DET. QTY PART NO. DESCRIPTION

1	4	160621	SPRING TIGHTENER HOOK BUSH
2	8	470118	1/4UNC X 3/4 FLANGE HEX BOLT
3	12	470121	1/4UNC HEX FLANGE LOCK NUT
4	2	358961	LEG BRACE CLEVIS WLD, 2100 99
5	2	359140	LEG BRACE WLD 284XP 2001
6	4	763490	SOLU TANK MT SUPP, 2100 98
7	1	659831	LWR FRONT SHIELD 280 89
8	1	660200	RH FRT POLY TANK SHLD WLD280XP
9	1	660201	LH FRT POLY TANK SHLD WLD280XP
10	1	763580	RH FRT SOLU TANK MT WLD 284XP
11	1	763581	LH FRT SOLU TANK MT WLD 284XP
12	1	763582	RH REAR SOLU TANK MT WLD 284XP
13	1	763583	LH REAR SOLU TANK MT WLD 284XP
14	4	900006	1/4UNC X 1 3/4 HEX BOLT
15	8	920000	1/4 SAE FLAT WASHER
16	2	900410	3/4UNC X 4" HEX BOLT
17	2	900814	1" UNC X 4" HEX BOLT GR8
18	12	900334	5/8UNC X 1 3/4 HEX BOLT
19	8	900412	3/4UNC X 5" HEX BOLT
20	2	910017	1" UNC HEX NUT
21	12	914010	5/8UNC HEX STOVER NUT
22	10	914012	3/4UNC HEX STOVER NUT
23	4	920008	1" SAE FLAT WASHER
24	2	920508	1" LOCK WASHER
25	12	470212	1/4 BONDED SEALING WASH, SS

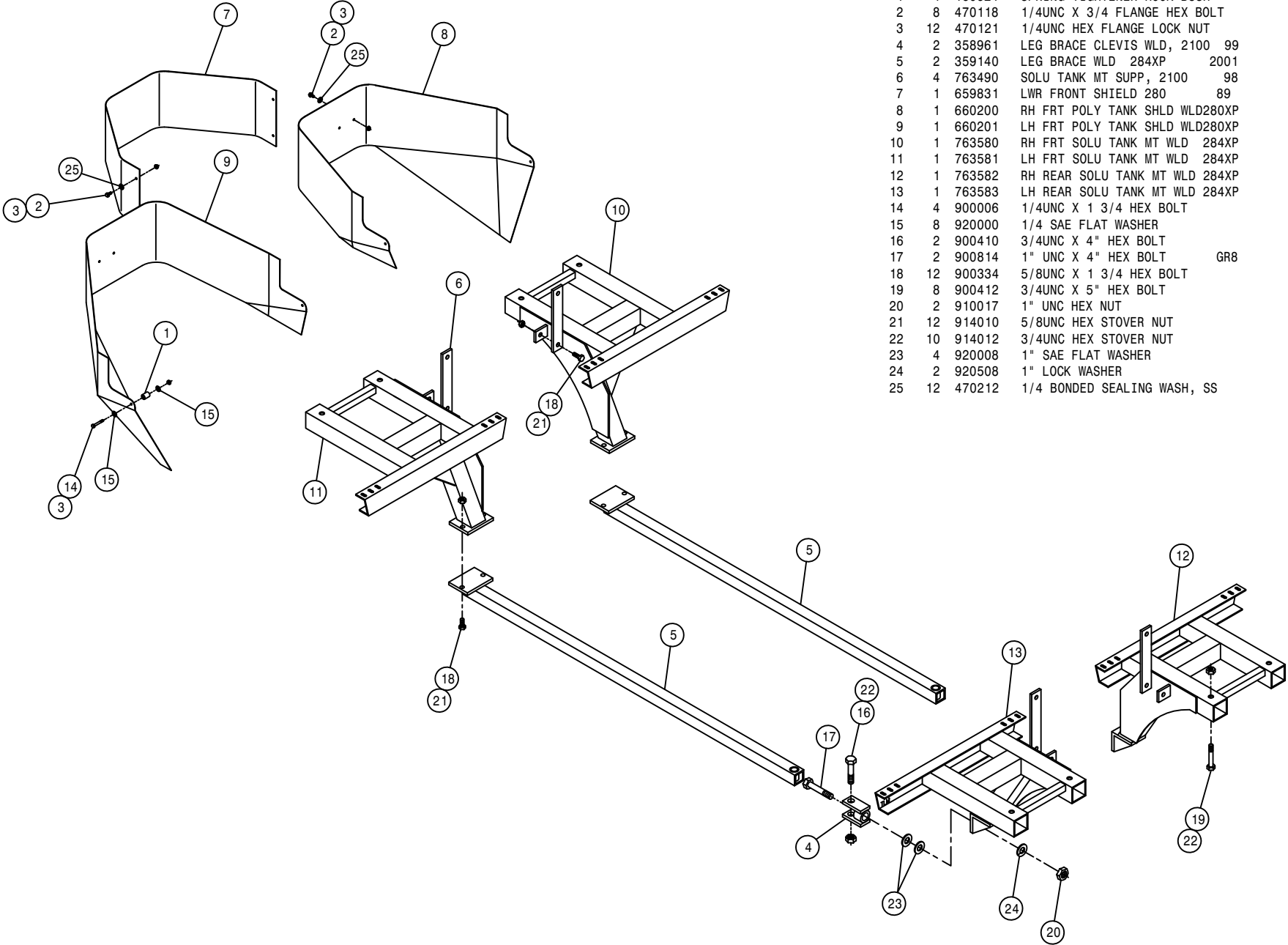

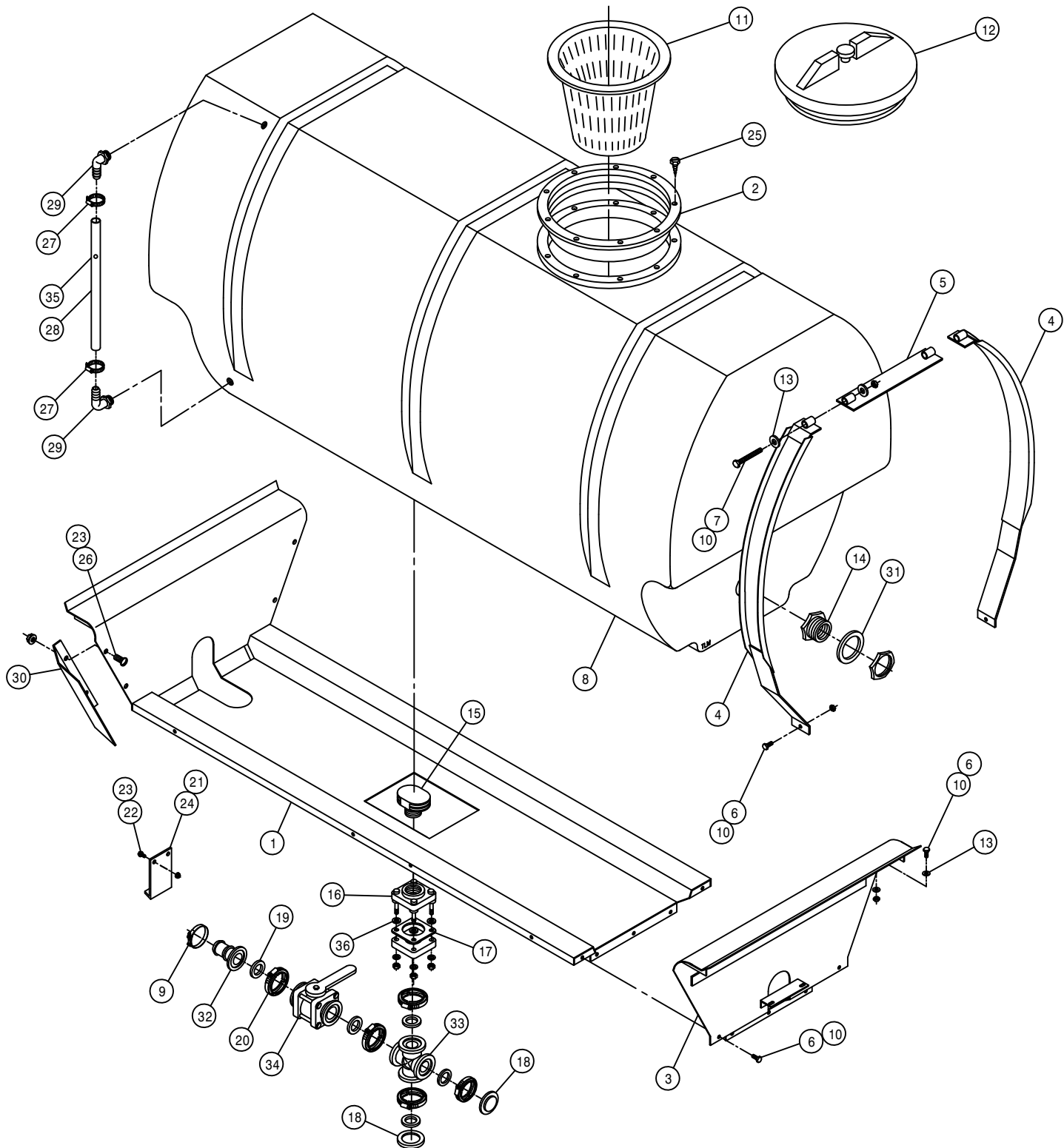

RH POLY 400 GALLON SOLUTION TANK ASSEMBLY

DET.	QTY	PART NO.	DESCRIPTION
	1	763434	POLY TANK CRADLE WELD, 284 94
	2	763409	10" THD'D RING FOR TANK LID
	3	763340	REAR POLY CRADLE MT WLD280 90
	4	763454	TANK BAND WLD, 284 POLY 95
	5	763456	TANK BAND TIE WLD,284 POLY 95
	6	900129	3/8UNC X 1" HEX BOLT
	7	906138	3/8UNC X 3 1/2 HEX BOLT FULL
	8	763440	400 GAL GRAY POLY SOLU TANK 94
	9	520133	1.81/2.06 T-BOLT HOSE CLAMP SS
	10	914004	3/8UNC HEX STOVER NUT
	11	763431	8" STRAINER BASKET, SOLU TANK
	12	763408	LID, THD'D W/VENT, POLY TANK
	13	920002	3/8 SAE FLAT WASHER
	14	618548	1.25 PLASTIC FTG ASSY POLYTNK
	15	500077	VENT CAP, 2" W/O SCREEN,POLY
	16	500179	2"FLG TANK FTG,BOTDRN BLT POLY
	17	500087	GASKET,2" TANK FLG 500076/179
	18	500156	2" FLANGE CAP PLUG POLY
	19	500158	1 1/2" GASKET FOR 2" FLANGE
	20	500160	2" FLANGE CLAMP, S.S.
	21	470000	CABLE TIE, 21" BLACK PLASTIC
	22	470118	1/4UNC X 3/4 FLANGE HEX BOLT
	23	470121	1/4UNC HEX FLANGE LOCK NUT
	24	763363	SOLU HOSE SUPPORT 280 POLY 91
	25	763410	S.S. SCREW FOR CAP RING
	26	472269	1/4UNC X 1/2 TRUSS HD BOLT
	27	520069	HOSE CLAMP NO 6 STAINLESS
	28	601245	HOSE, 1/2 X 42 CLEAR VINYL
	29	618556	1/4NPT-90-1/2 HOSE BARB,POLY
	30	763436	RH SIGHT GAGE SHLD,POLY284 94
	31	763430	1 1/4 TANK FLANGE RUBBER SEAL
	32	500162	2" FLANGE-1 1/2 HOSE BARB POLY
	33	500176	2" FLANGE CROSS POLY
	34	696142	BALL VLV, 2" FLANGE
	35	763446	RED POLYPROPYLENE BALL 25/64"
	36	500100	FOOT GASKET,2" FLG 500076/179



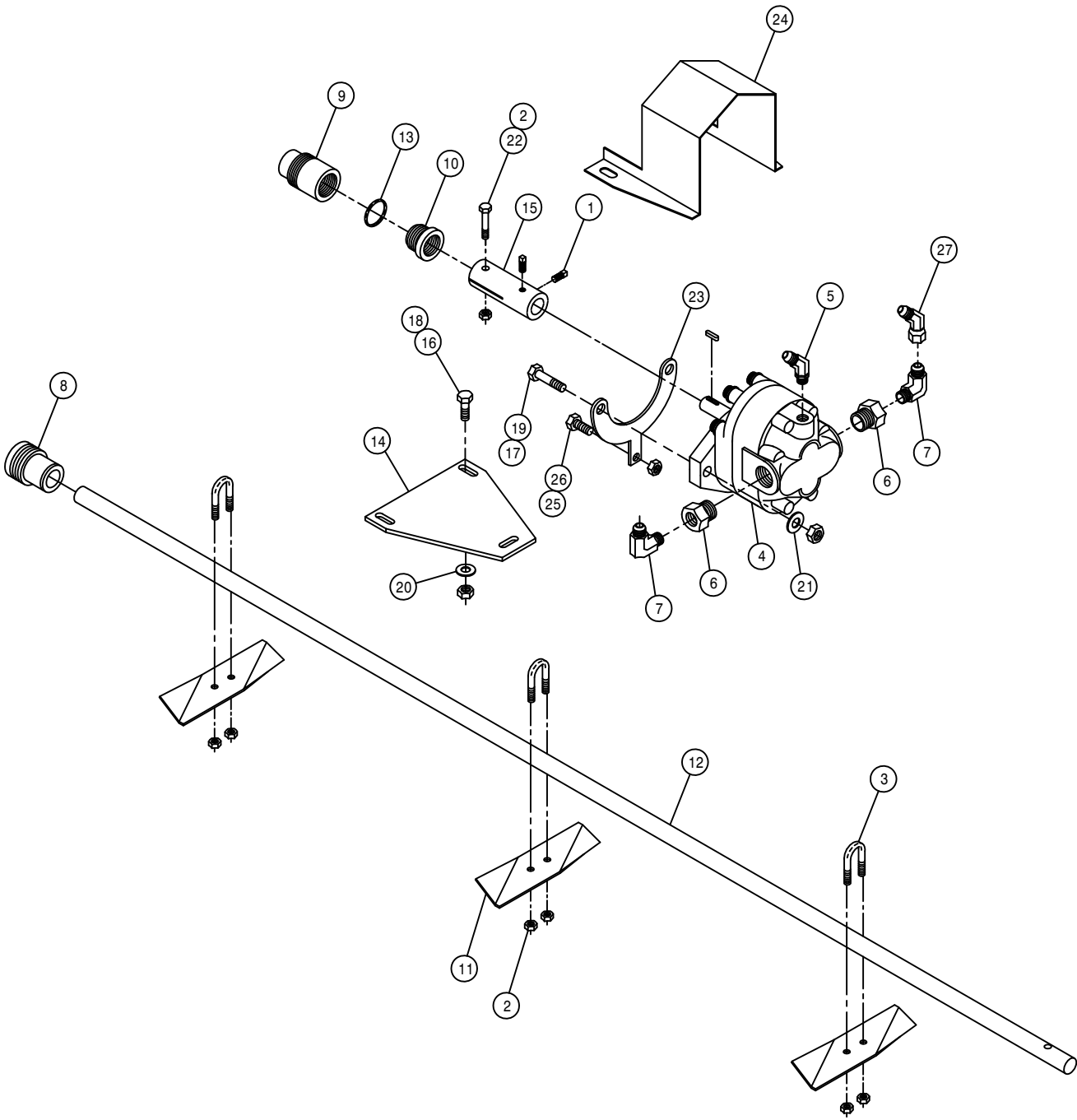

RH POLY TANK AGITATION ASSEMBLY

DET. QTY PART NO. DESCRIPTION

1	2	470199	1/4UNC X 3/8 SQHD CUP SET SCR	
2	7	470089	1/4UNC HEX LOC NUT NYL INS SS	
3	3	470092	1/4UNC-3/4ID-1 1/4 U-BOLT SS	
4	1	610510	CESSNA GEAR MOTOR 1.48CI	
5	1	618338	9/16MJIC-45-1/4MNPT LBO	
6	2	618092	1 1/16MOR-1/2FNPT ADPTR	
7	2	618107	9/16MJIC-90-1/2MNPT LBO	
8	1	706403	FRT AGIT SHFT BRG, NYLON	
9	1	706401	REAR AGIT SHFT BRG, NYLON	
10	1	706402	AGIT SHFT GLAND NUT, NYLON	
11	3	763027	AGIT IMPELLER	
12	1	763360	AGIT SHAFT 280	91
13	1	763217	GLAND PACKING, 13 IN. LONG	
14	1	763357	AGIT MTR MT PLT CES 280	91
15	1	763359	AGIT MTR CPLR 280	91
16	2	900064	5/16UNC X 3/4 HEX BOLT	
17	2	900130	3/8UNC X 1 1/4 HEX BOLT	
18	2	914002	5/16UNC HEX STOVER NUT	
19	2	914004	3/8UNC HEX STOVER NUT	
20	2	920001	5/16 SAE FLAT WASHER	
21	2	920002	3/8 SAE FLAT WASHER	
22	1	470200	1/4UNC X 1 3/4 HEX BOLT SS	
23	1	763358	AGIT MTR MT YOKE CES 280	91
24	1	763361	AGIT CPLR SHIELD 280	91
25	1	900000	1/4UNC X 1/2 HEX BOLT	
26	1	914000	1/4UNC HEX STOVER NUT	
27	1	618634	9/16MJIC-45-9/16FJIC SWIV LBO	

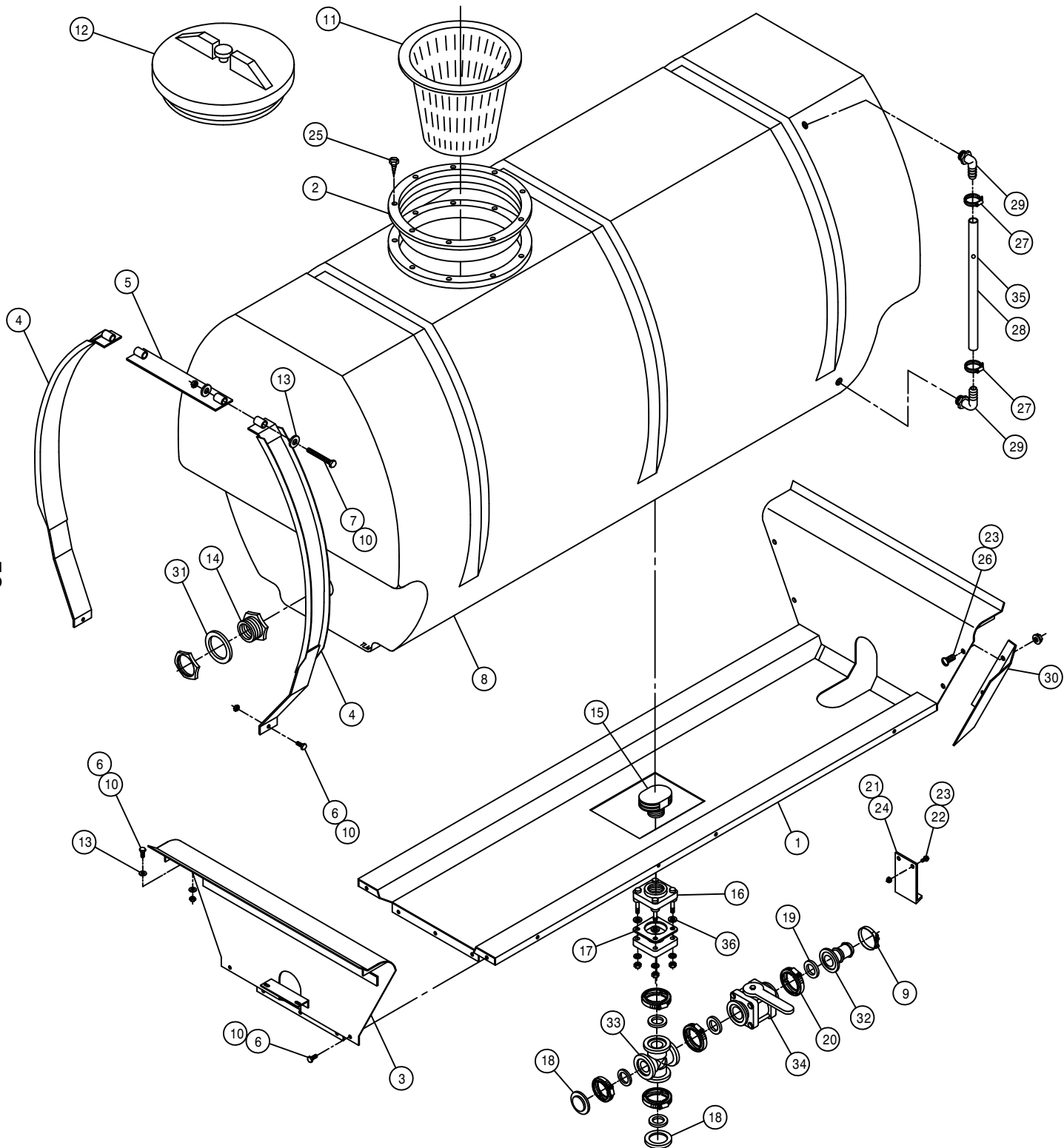

LH POLY 400 GALLON SOLUTION TANK ASSEMBLY

DET.	QTY	PART NO.	DESCRIPTION
1	1	763434	POLY TANK CRADLE WELD, 284 94
2	1	763409	10" THD'D RING FOR TANK LID
3	1	763340	REAR POLY CRADLE MT WLD280 90
4	6	763454	TANK BAND WLD, 284 POLY 95
5	3	763456	TANK BAND TIE WLD,284 POLY 95
6	15	900129	3/8UNC X 1" HEX BOLT
7	6	906138	3/8UNC X 3 1/2 HEX BOLT FULL
8	1	763440	400 GAL GRAY POLY SOLU TANK 94
9	1	520133	1.81/2.06 T-BOLT HOSE CLAMP SS
10	21	914004	3/8UNC HEX STOVER NUT
11	1	763431	8" STRAINER BASKET, SOLU TANK
12	1	763408	LID, THD'D W/VENT, POLY TANK
13	20	920002	3/8 SAE FLAT WASHER
14	2	618548	1.25 PLASTIC FTG ASSY POLYTNK
15	1	500077	VENT CAP, 2" W/O SCREEN,POLY
16	1	500179	2"FLG TANK FTG,BOTDRN BLT POLY
17	1	500087	GASKET,2" TANK FLG 500076/179
18	2	500156	2" FLANGE CAP PLUG POLY
19	5	500158	1 1/2" GASKET FOR 2" FLANGE
20	5	500160	2" FLANGE CLAMP, S.S.
21	1	470000	CABLE TIE, 21" BLACK PLASTIC
22	2	470118	1/4UNC X 3/4 FLANGE HEX BOLT
23	4	470121	1/4UNC HEX FLANGE LOCK NUT
24	1	763363	SOLU HOSE SUPPORT 280 POLY 91
25	8	763410	S.S. SCREW FOR CAP RING
26	2	472269	1/4UNC X 1/2 TRUSS HD BOLT
27	2	520069	HOSE CLAMP NO 6 STAINLESS
28	1	601245	HOSE, 1/2 X 42 CLEAR VINYL
29	2	618556	1/4NPT-90-1/2 HOSE BARB,POLY
30	1	763437	LH SIGHT GAGE SHLD,POLY284 94
31	2	763430	1 1/4 TANK FLANGE RUBBER SEAL
32	1	500162	2" FLANGE-1 1/2 HOSE BARB POLY
33	1	500176	2" FLANGE CROSS POLY
34	1	696142	BALL VLV, 2" FLANGE
35	1	763446	RED POLYPROPYLENE BALL 25/64"
36	4	500100	FOOT GASKET,2" FLG 500076/179

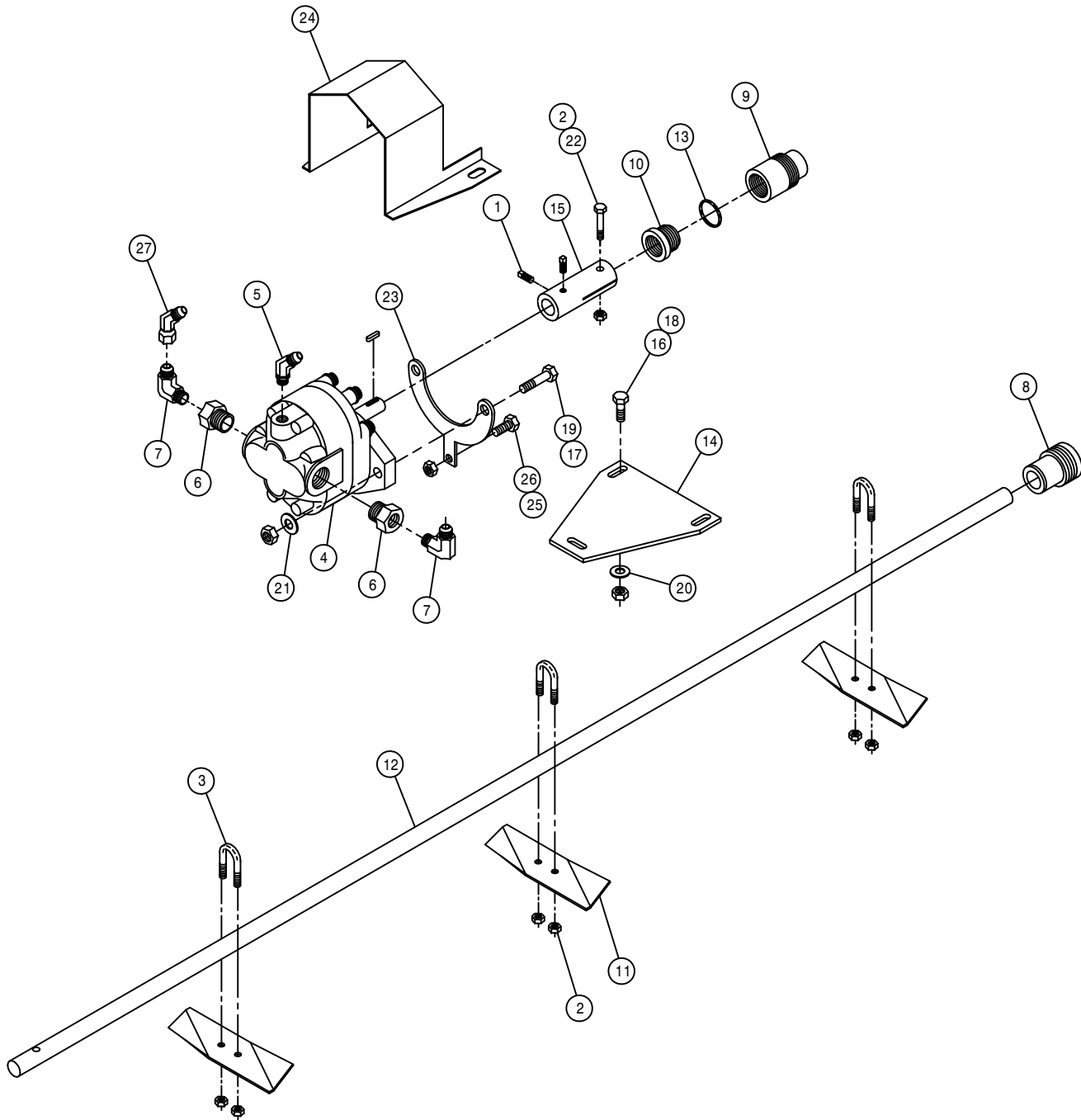

LH POLY TANK AGITATION ASSEMBLY

DET.	QTY	PART NO.	DESCRIPTION
1	2	470199	1/4UNC X 3/8 SQHD CUP SET SCR
2	7	470089	1/4UNC HEX LOC NUT NYL INS SS
3	3	470092	1/4UNC-3/4ID-1 1/4 U-BOLT SS
4	1	610510	CESSNA GEAR MOTOR 1.48CI
5	1	618338	9/16MJIC-45-1/4MNPT LBO
6	2	618092	1 1/16MOR-1/2FNPT ADPTR
7	2	618107	9/16MJIC-90-1/2MNPT LBO
8	1	706403	FRT AGIT SHFT BRG, NYLON
9	1	706401	REAR AGIT SHFT BRG, NYLON
10	1	706402	AGIT SHFT GLAND NUT, NYLON
11	3	763027	AGIT IMPELLER
12	1	763360	AGIT SHAFT 280 91
13	1	763217	GLAND PACKING, 13 IN. LONG
14	1	763357	AGIT MTR MT PLT CES 280 91
15	1	763359	AGIT MTR CPLR 280 91
16	2	900064	5/16UNC X 3/4 HEX BOLT
17	2	900130	3/8UNC X 1 1/4 HEX BOLT
18	2	914002	5/16UNC HEX STOVER NUT
19	2	914004	3/8UNC HEX STOVER NUT
20	2	920001	5/16 SAE FLAT WASHER
21	2	920002	3/8 SAE FLAT WASHER
22	1	470200	1/4UNC X 1 3/4 HEX BOLT SS
23	1	763358	AGIT MTR MT YOKE CES 280 91
24	1	763361	AGIT CPLR SHIELD 280 91
25	1	900000	1/4UNC X 1/2 HEX BOLT
26	1	914000	1/4UNC HEX STOVER NUT
27	1	618634	9/16MJIC-45-9/16FJIC SWIV LBO

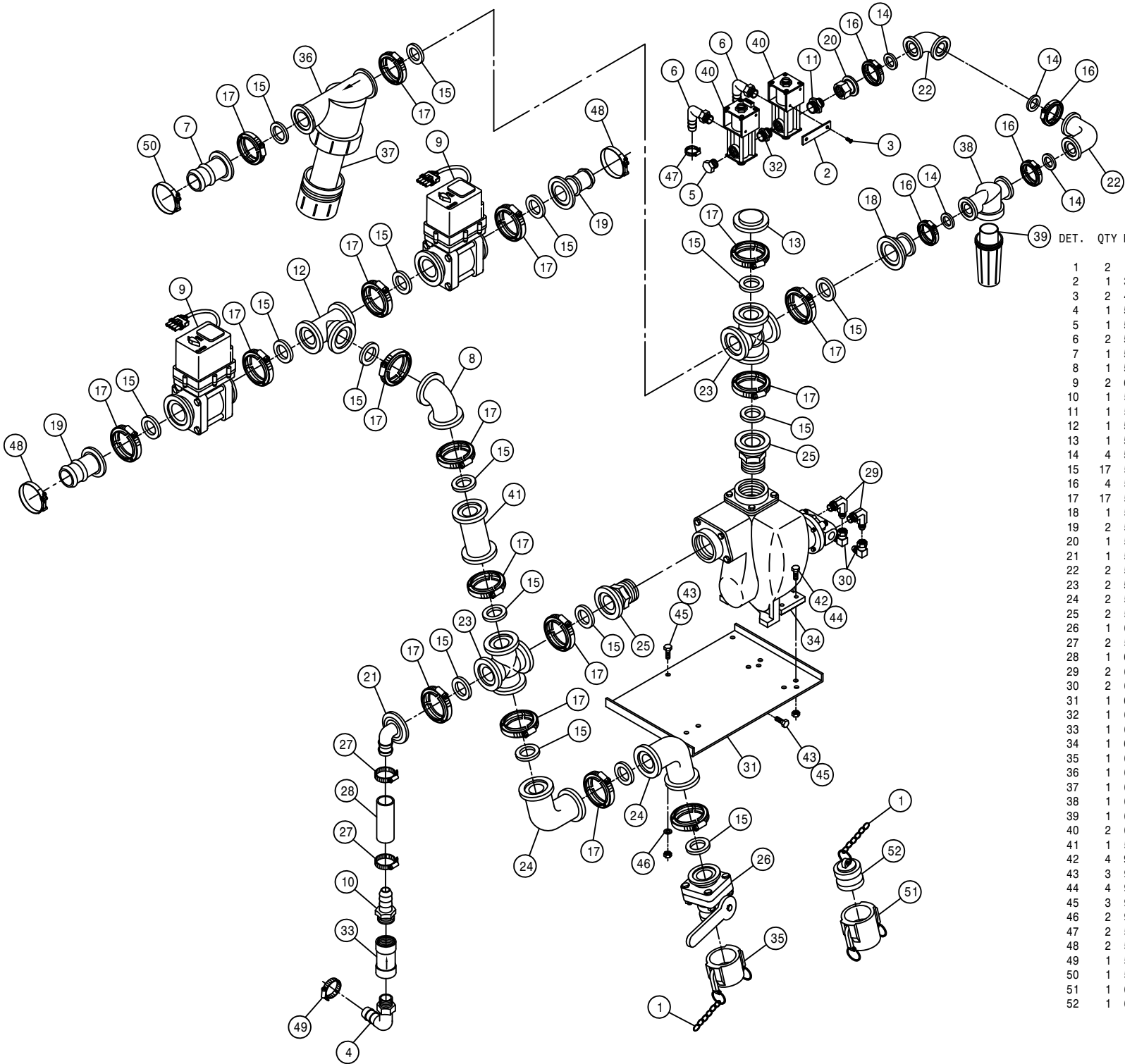

SOLUTION PUMP ASSEMBLY

DET.	QTY	PART NO.	DESCRIPTION
	1	2 160986	CHAIN, 12.00 LONG
	2	1 342014	SOLENOID KEEPER, RINSE SYS
	3	2 472199	10-24 X 1/2 RD HD MACH SCR
	4	1 500024	1"NPT-90-1"HOSE BARB, POLY
	5	1 500043	3/4NPT PIPE PLUG, POLY
	6	2 500047	1/2NPT-90-1/2 HOSE BARB, POLY
	7	1 500154	2" FLANGE-2" HOSE BARB POLY
	8	1 500225	2"FLANGE-45-2"FLANGE LBO POLY
	9	2 696176	ELECT BALL VLV,2"FLANGE BANJO
	10	1 500074	1"NPT-1" HOSE BARB, POLY
	11	1 500085	1" X 3/4NPT REDU NIPPLE, POLY
	12	1 500151	2" FLANGE TEE POLY
	13	1 500156	2" FLANGE CAP PLUG POLY
	14	4 500157	1" FLANGE GASKET EPDM
	15	17 500158	1 1/2" GASKET FOR 2" FLANGE
	16	4 500159	1" FLANGE CLAMP, S.S.
	17	17 500160	2" FLANGE CLAMP, S.S.
	18	1 500161	2"FLANGE-1"FLANGE COUPLER,POLY
	19	2 500162	2" FLANGE-1 1/2 HOSE BARB POLY
	20	1 500168	1" FLANGE-1" FNPT ADPTR POLY
	21	1 500189	2" FLANGE-90-1" HOSE BARB POLY
	22	2 500174	1" FLANGE-90-1" FLANGE LBOPOLY
	23	2 500176	2" FLANGE CROSS POLY
	24	2 500180	2"FLANGE-90-2"FLANGE LBO POLY
	25	2 500182	2" FLANGE-2"MNPT ADPTR S.S.
	26	1 696141	BALL VLV,2"FLANGE/2"MALE ADPTR
	27	2 520087	HOSE CLAMP NO 20 STAINLESS
	28	1 601463	HOSE, 1 X 4 2BR BLK EPDM
	29	2 618241	3/4MJIC-90-3/4MOR LBO
	30	2 618609	3/4MJIC-90-3/4FJIC SWIV LBO
	31	1 690530	2" SOLU PUMP MT WLD 95
	32	1 690098	3/4NPT CLOSE NIPPLE, POLY
	33	1 690488	1.00 CHECK VLV, SPRING LOADED
	34	1 690552	FLOMAX 8, 2" PUMP
	35	1 690623	CAP FOR 2.00 MALE COUPLER POLY
	36	1 690628	LINE "Y" STRAINER, 2" FLANGE
	37	1 690629	50 MESH SCREEN FOR 690628
	38	1 690660	LINE "T" STRAINER, 1" FLANGE
	39	1 690661	50 MESH SCREEN FOR 690660
	40	2 695952	SOLUTION VALVE, AA144-1 VITON
	41	1 500177	2" FLANGE-2" FLANGE CPLR POLY
	42	4 900066	5/16UNC X 1 1/4 HEX BOLT
	43	3 900129	3/8UNC X 1" HEX BOLT
	44	4 914002	5/16UNC HEX STOVER NUT
	45	3 914004	3/8UNC HEX STOVER NUT
	46	2 920002	3/8 SAE FLAT WASHER
	47	2 520070	HOSE CLAMP NO 8 STAINLESS
	48	2 520133	1.81/2.06 T-BOLT HOSE CLAMP SS
	49	1 520138	1.38/1.56 T-BOLT HOSE CLAMP
	50	1 520141	2.31/2.62 T-BOLT HOSE CLAMP SS
	51	1 690390	2.00FNPT-FEMALE COUPLER POLY
	52	1 690392	PLUG FOR 2.00 FEMALE COUPLER

60' SOLUTION SOLENOID ASSEMBLY (STANDARD)

DET. QTY PART NO. DESCRIPTION

DET.	QTY	PART NO.	DESCRIPTION
1	1	164422	SOLU MANIF VLV MT, HIVOL
2	3	520090	HOSE CLAMP NO 16 STAINLESS
3	1	601451	HOSE, 2 X 69 2F-1W EPDM
4	3	500173	1" FLANGE-90-1" HOSE BARB POLY
5	2	500154	2" FLANGE-2" HOSE BARB POLY
6	5	500157	1" FLANGE GASKET EPDM
7	7	500158	1 1/2" GASKET FOR 2" FLANGE
8	5	500159	1" FLANGE CLAMP, S.S.
9	7	500160	2" FLANGE CLAMP, S.S.
10	4	914004	3/8UNC HEX STOVER NUT
11	2	470136	3/8UNC-3 1/16ID-3 SQ U-BOLT
12	1	500180	2"FLANGE-90-2"FLANGE LBO POLY
13	1	500181	2" FLANGE PLUG W/1/4"FNPT POLY
14	1	690359	PRESSURE GA GLYCERI 100 PSI
15	1	696178	ELECT 3-BALL VLV,2"FLANGE TJET
16	3	696502	OUTLET FLG END-CAP FOR 696178
17	2	696503	O-RING,VLV FITTING FOR 696178
18	2	696504	CLAMP,VLV FITTING FOR 696178
19	3	520141	2.31/2.62 T-BOLT HOSE CLAMP SS
20	1	500058	2"NPT X 2" H BARB, POLY
21	1	601450	HOSE, 2 X 84 2F-1W EPDM
22	2	520056	HOSE CLAMP NO 56 STAINLESS
23	2	470118	1/4UNC X 3/4 FLANGE HEX BOLT
24	1	690529	RFM 100 FLOW METER, RAVEN
25	3	696501	FLANGE VLV TEE FOR 696178
26	3	900064	5/16UNC X 3/4 HEX BOLT
27	3	914002	5/16UNC HEX STOVER NUT
28	3	696500	450EC VLV W/FLG TEE FOR 696178
29	1	500119	1/2"NPT BR TEE-1/2"HBARB, POLY
30	1	500151	2" FLANGE TEE POLY
31	1	500175	1" FLANGE TEE POLY
32	1	500224	2" FLANGE PLUG W/1/2"FNPT POLY
33	1	500226	1" FLANGE PLUG W/1/4"FNPT POLY
34	1	618556	1/4NPT-90-1/2 HOSE BARB,POLY
35	3	520070	HOSE CLAMP NO 8 STAINLESS
36	1	500152	2" FLANGE-2" MNPT ADPTR POLY
37	1	690535	CONTROL VALVE,1 1/2"POLY,RAVN
38	2	470121	1/4UNC HEX FLANGE LOCK NUT

NOTE: ITEMS MARKED WITH A (\*) ARE SOLUTION VALVE REPAIR PARTS.

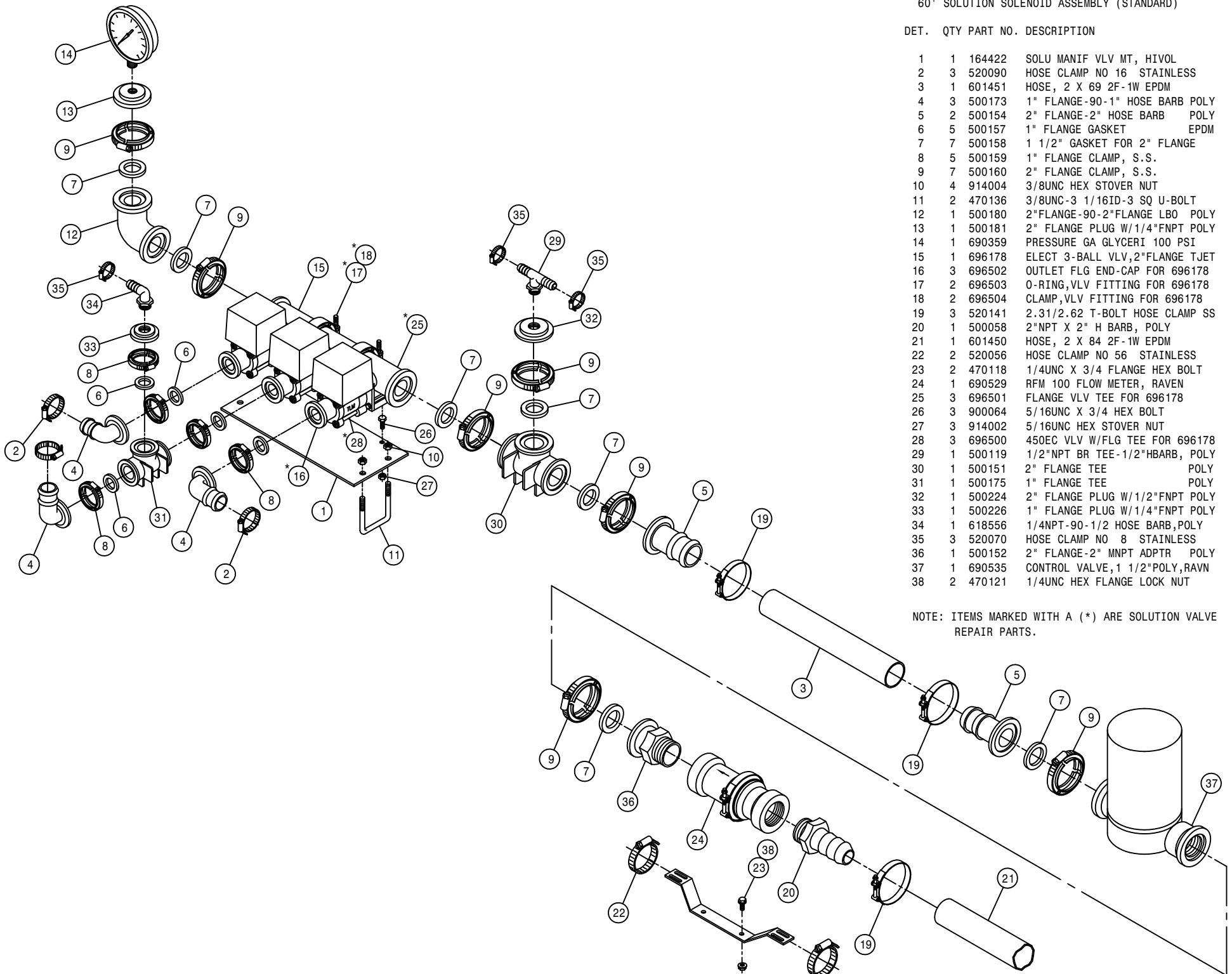

DET. QTY PART NO. DESCRIPTION

DET.	QTY	PART NO.	DESCRIPTION
1	1	164422	SOLU MANIF VLV MT, HIVAL
2	5	520090	HOSE CLAMP NO 16 STAINLESS
3	2	500151	2" FLANGE TEE POLY
4	3	500173	1" FLANGE-90-1" HOSE BARB POLY
5	2	500154	2" FLANGE-2" HOSE BARB POLY
6	5	500157	1" FLANGE GASKET EPDM
7	9	500158	1 1/2" GASKET FOR 2" FLANGE
8	5	500159	1" FLANGE CLAMP, S.S.
9	9	500160	2" FLANGE CLAMP, S.S.
10	4	914004	3/8UNC HEX STOVER NUT
11	2	500172	2" FLANGE-1" HOSE BARB POLY
12	1	500180	2" FLANGE-90-2" FLANGE LBO POLY
13	1	500181	2" FLANGE PLUG W/1/4" FNPT POLY
14	1	690359	PRESSURE GA GLYCERI 100 PSI
15	1	696178	ELECT 3-BALL VLV, 2" FLANGE TJET
16	3	696502	OUTLET FLG END-CAP FOR 696178
17	2	696503	O-RING, VLV FITTING FOR 696178
18	2	696504	CLAMP, VLV FITTING FOR 696178
19	3	520141	2.31/2.62 T-BOLT HOSE CLAMP SS
20	1	500058	2" NPT X 2" H BARB, POLY
21	1	601450	HOSE, 2 X 84 2F-1W EPDM
22	2	520056	HOSE CLAMP NO 56 STAINLESS
23	2	470118	1/4UNC X 3/4 FLANGE HEX BOLT
24	1	690529	RFM 100 FLOW METER, RAVEN
25	1	601451	HOSE, 2 X 69 2F-1W EPDM
26	2	470136	3/8UNC-3 1/16ID-3 SQ U-BOLT
27	3	696501	FLANGE VLV TEE FOR 696178
28	3	900064	5/16UNC X 3/4 HEX BOLT
29	3	914002	5/16UNC HEX STOVER NUT
30	1	696500	450EC VLV W/FLG TEE FOR 696178
31	1	500175	1" FLANGE TEE POLY
32	1	500226	1" FLANGE PLUG W/1/4" FNPT POLY
33	1	618556	1/4NPT-90-1/2 HOSE BARB, POLY
34	1	520070	HOSE CLAMP NO 8 STAINLESS
35	1	500152	2" FLANGE-2" MNPT ADPTR POLY
36	1	690535	CONTROL VALVE, 1 1/2" POLY, RAVN
37	2	470121	1/4UNC HEX FLANGE LOCK NUT

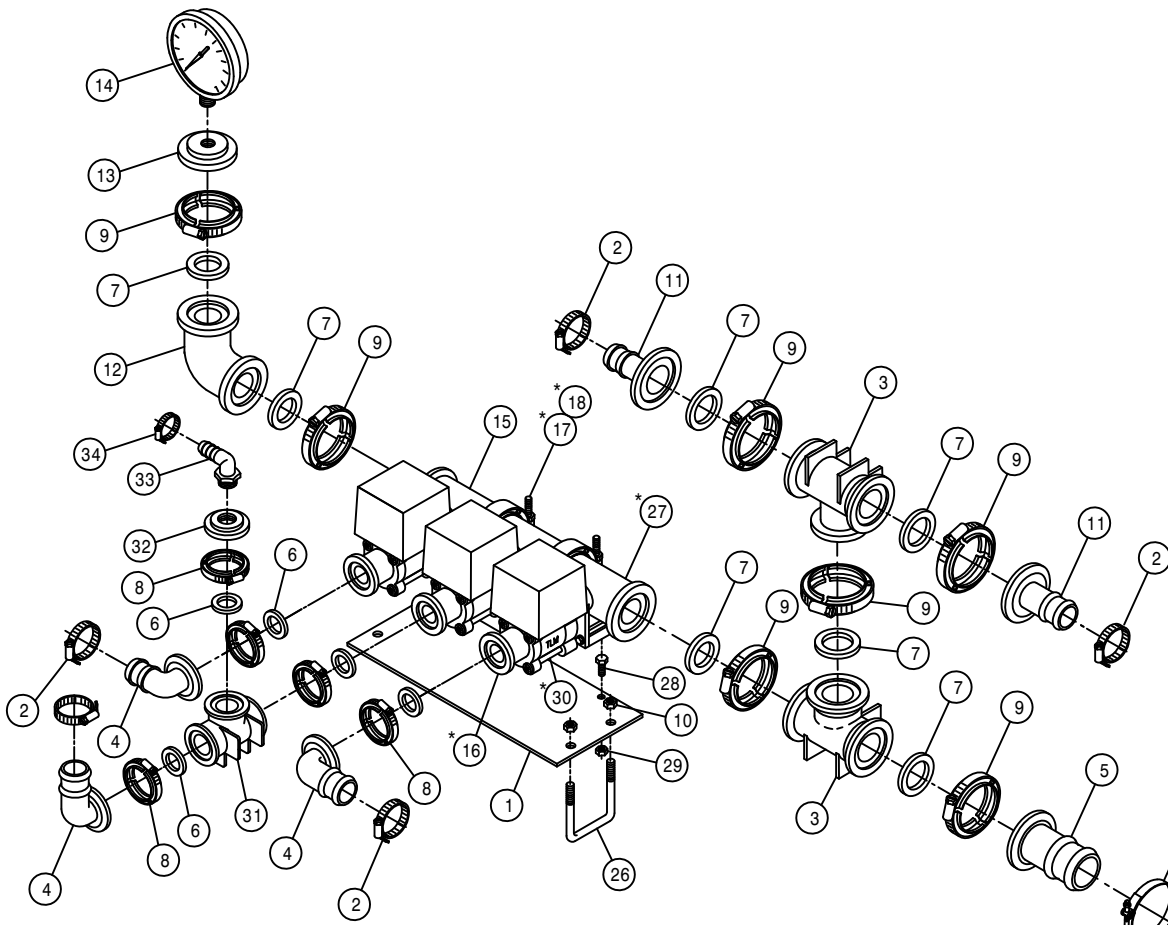

NOTE: ITEMS MARKED WITH A (\*) ARE SOLUTION VALVE REPAIR PARTS.

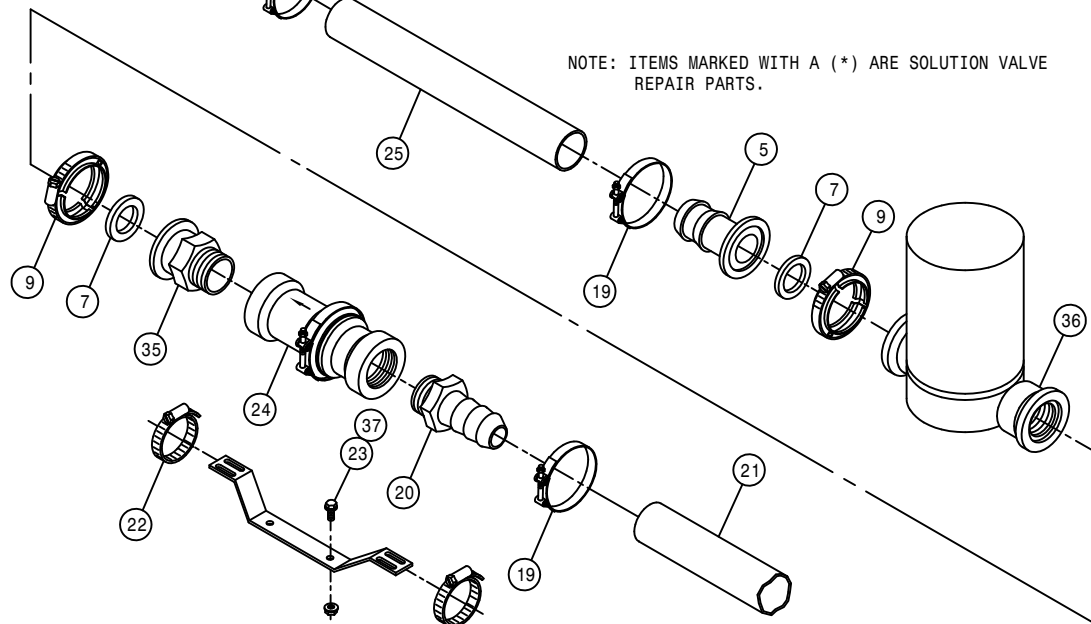

80' -90' OUTER BOOM SOLENOID (STANDARD)

DET. QTY PART NO. DESCRIPTION

DET.	QTY	PART NO.	DESCRIPTION	
1	1	164303	SOLU VLV MT	97
2	1	164304	SOLU VLV MT KEEPER	97
3	2	520090	HOSE CLAMP NO 16 STAINLESS	
4	4	500157	1" FLANGE GASKET	EPDM
5	4	500159	1" FLANGE CLAMP, S.S.	
6	1	500171	1" FLANGE-1" HOSE BARB	POLY
7	1	500173	1" FLANGE-90-1" HOSE BARB	POLY
8	1	696177	ELECT BALL VLV, 1" FLANGE	TJET
9	2	900007	1/4UNC X 2" HEX BOLT	
10	2	914000	1/4UNC HEX STOVER NUT	
11	1	500175	1" FLANGE TEE	POLY
12	1	500226	1" FLANGE PLUG W/1/4"FNPT	POLY
13	1	618556	1/4NPT-90-1/2 HOSE BARB, POLY	
14	1	520070	HOSE CLAMP NO 8 STAINLESS	

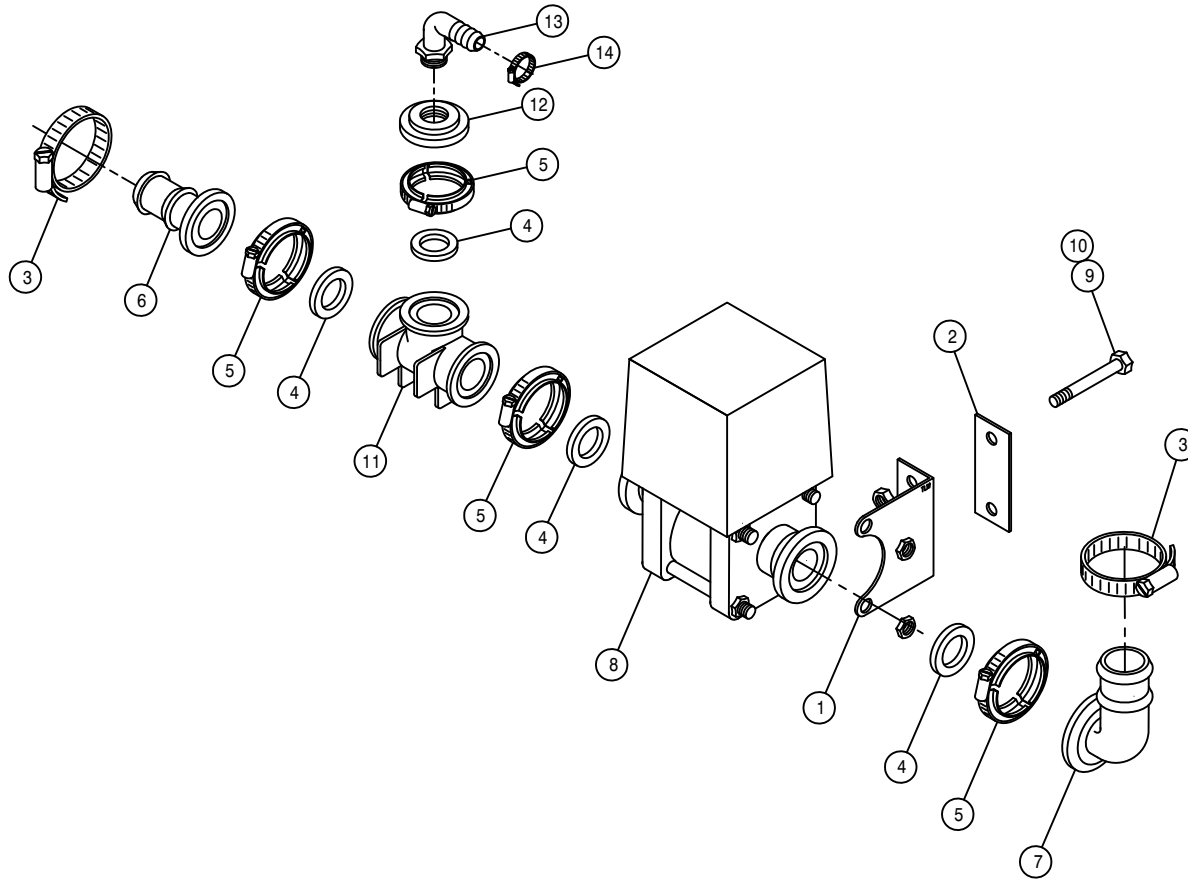

AGITATOR HYD. HOSE COVER

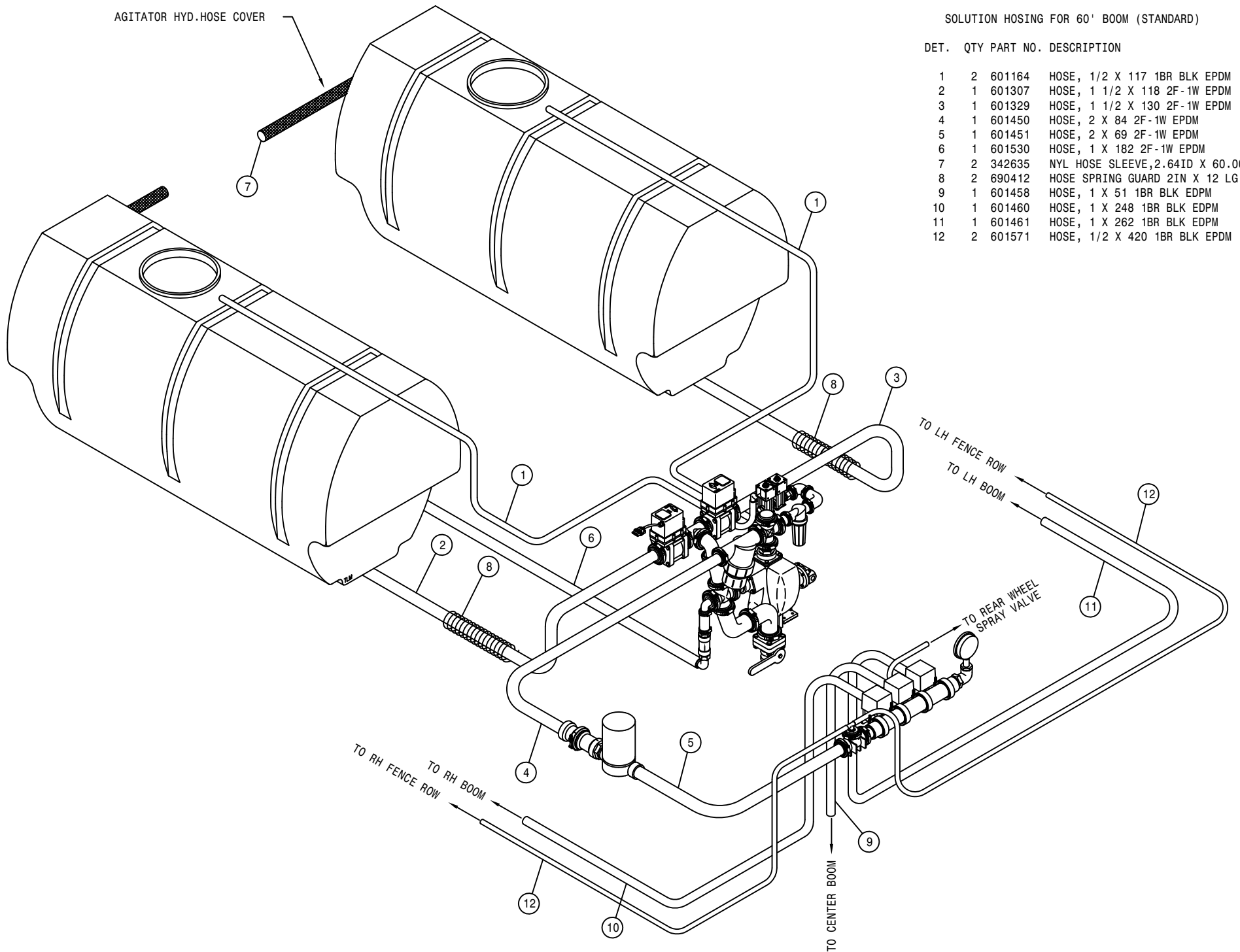

SOLUTION HOISING FOR 60' BOOM (STANDARD)

DET. QTY PART NO. DESCRIPTION

DET.	QTY	PART NO.	DESCRIPTION
1	2	601164	HOSE, 1/2 X 117 1BR BLK EPDM
2	1	601307	HOSE, 1 1/2 X 118 2F-1W EPDM
3	1	601329	HOSE, 1 1/2 X 130 2F-1W EPDM
4	1	601450	HOSE, 2 X 84 2F-1W EPDM
5	1	601451	HOSE, 2 X 69 2F-1W EPDM
6	1	601530	HOSE, 1 X 182 2F-1W EPDM
7	2	342635	NYL HOSE SLEEVE, 2.64ID X 60.00
8	2	690412	HOSE SPRING GUARD 2IN X 12 LG
9	1	601458	HOSE, 1 X 51 1BR BLK EDPM
10	1	601460	HOSE, 1 X 248 1BR BLK EDPM
11	1	601461	HOSE, 1 X 262 1BR BLK EDPM
12	2	601571	HOSE, 1/2 X 420 1BR BLK EPDM



SOLUTION HOISING FOR 80' -90' BOOM (STANDARD)

DET. QTY PART NO. DESCRIPTION

DET.	QTY	PART NO.	DESCRIPTION
1	2	601164	HOSE, 1/2 X 117 1BR BLK EPDM
2	1	601307	HOSE, 1 1/2 X 118 2F-1W EPDM
3	1	601329	HOSE, 1 1/2 X 130 2F-1W EPDM
4	1	601450	HOSE, 2 X 84 2F-1W EPDM
5	1	601451	HOSE, 2 X 69 2F-1W EPDM
6	1	601530	HOSE, 1 X 182 2F-1W EPDM
7	2	342635	NYL HOSE SLEEVE, 2.64ID X 60.00
8	2	690412	HOSE SPRING GUARD 2IN X 12 LG
9	1	601458	HOSE, 1 X 51 1BR BLK EDPM
10	1	601459	HOSE, 1 X 245 1BR BLK EDPM
11	1	601460	HOSE, 1 X 248 1BR BLK EDPM
12	1	601461	HOSE, 1 X 262 1BR BLK EDPM
13	1	601462	HOSE, 1 X 294 1BR BLK EDPM
14	2	601390	HOSE, 1 X 160 1BR BLK EPDM
15	2	601570	HOSE, 1/2 X 236 1BR BLK EPDM
16	2	601167	HOSE, 1/2 X 300 1BR BLK EPDM

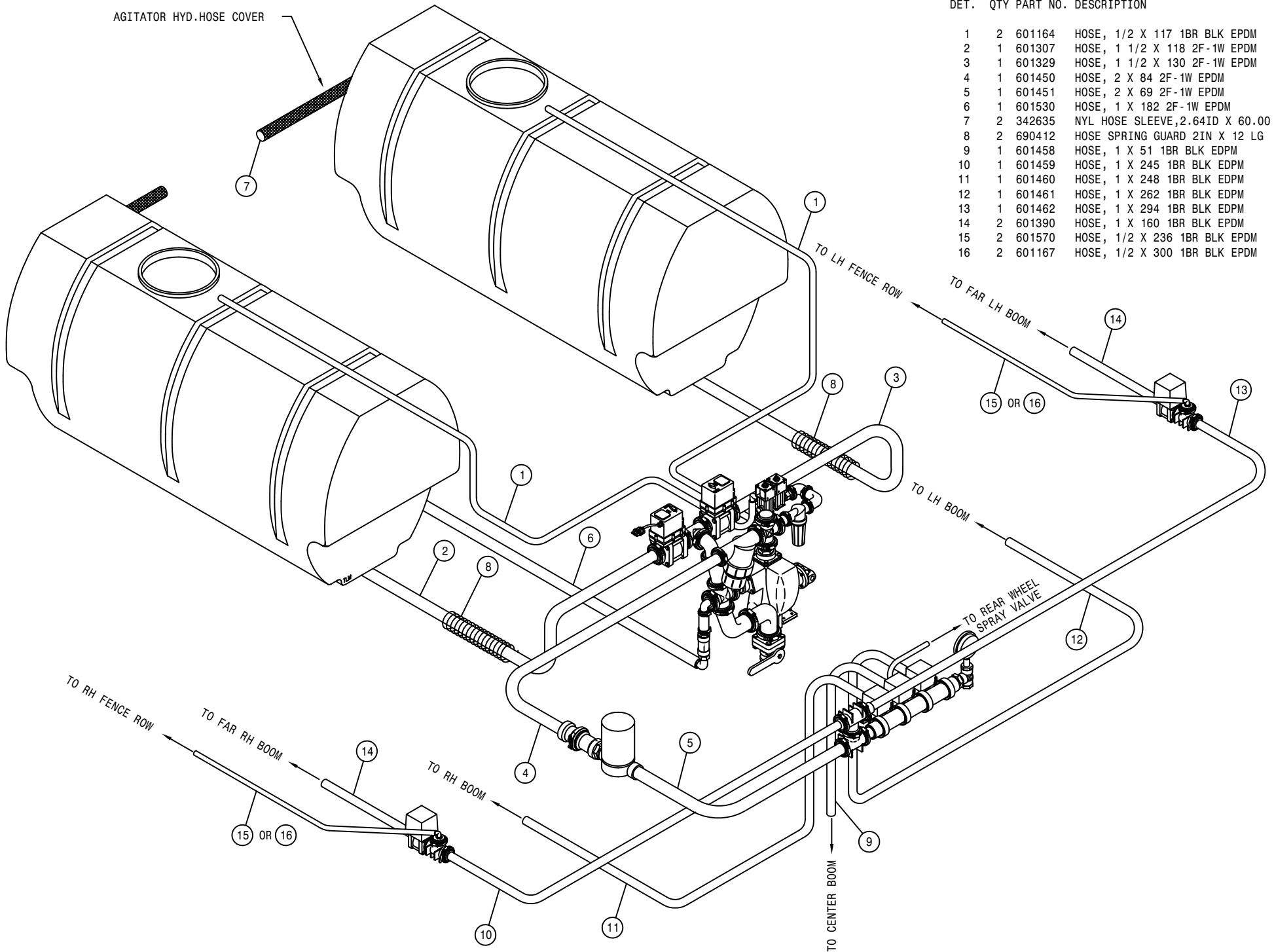

AGITATOR HYD. HOSE COVER

AGITATOR HYD. HOSE COVER

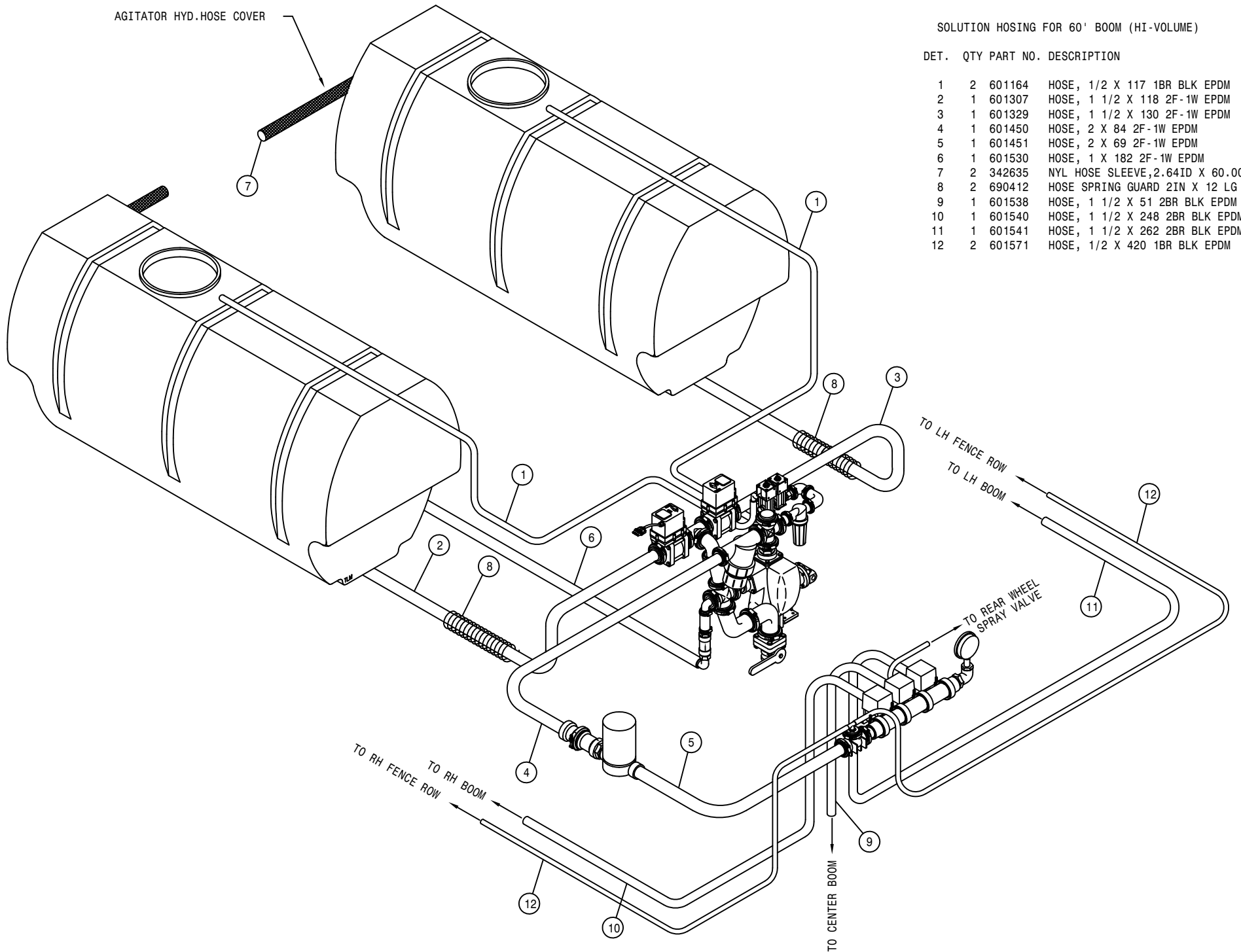

SOLUTION HOISING FOR 60' BOOM (HI-VOLUME)

DET. QTY PART NO. DESCRIPTION

1	2	601164	HOSE, 1/2 X 117 1BR BLK EPDM
2	1	601307	HOSE, 1 1/2 X 118 2F-1W EPDM
3	1	601329	HOSE, 1 1/2 X 130 2F-1W EPDM
4	1	601450	HOSE, 2 X 84 2F-1W EPDM
5	1	601451	HOSE, 2 X 69 2F-1W EPDM
6	1	601530	HOSE, 1 X 182 2F-1W EPDM
7	2	342635	NYL HOSE SLEEVE, 2.64ID X 60.00
8	2	690412	HOSE SPRING GUARD 2IN X 12 LG
9	1	601538	HOSE, 1 1/2 X 51 2BR BLK EPDM
10	1	601540	HOSE, 1 1/2 X 248 2BR BLK EPDM
11	1	601541	HOSE, 1 1/2 X 262 2BR BLK EPDM
12	2	601571	HOSE, 1/2 X 420 1BR BLK EPDM

SOLUTION HOISING FOR 80'-90' BOOM (HI-VOLUME)

DET. QTY PART NO. DESCRIPTION

1	2	601164	HOSE, 1/2 X 117 1BR BLK EPDM
2	1	601307	HOSE, 1 1/2 X 118 2F-1W EPDM
3	1	601329	HOSE, 1 1/2 X 130 2F-1W EPDM
4	1	601450	HOSE, 2 X 84 2F-1W EPDM
5	1	601451	HOSE, 2 X 69 2F-1W EPDM
6	1	601530	HOSE, 1 X 182 2F-1W EPDM
7	2	342635	NYL HOSE SLEEVE, 2.64ID X 60.00
8	2	690412	HOSE SPRING GUARD 2IN X 12 LG
9	1	601538	HOSE, 1 1/2 X 51 2BR BLK EPDM
10	1	601539	HOSE, 1 1/2 X 245 2BR BLK EPDM
11	1	601540	HOSE, 1 1/2 X 248 2BR BLK EPDM
12	1	601541	HOSE, 1 1/2 X 262 2BR BLK EPDM
13	1	601542	HOSE, 1 1/2 X 294 2BR BLK EPDM
14	2	601444	HOSE, 1 1/2 X 51 2F-1W EPDM
15	2	601469	HOSE, 1 1/2 X 110 2F-1W EPDM
16	2	601445	HOSE, 1 1/2 X 160 2F-1W EPDM
17	2	601570	HOSE, 1/2 X 236 1BR BLK EPDM
18	2	601167	HOSE, 1/2 X 300 1BR BLK EPDM

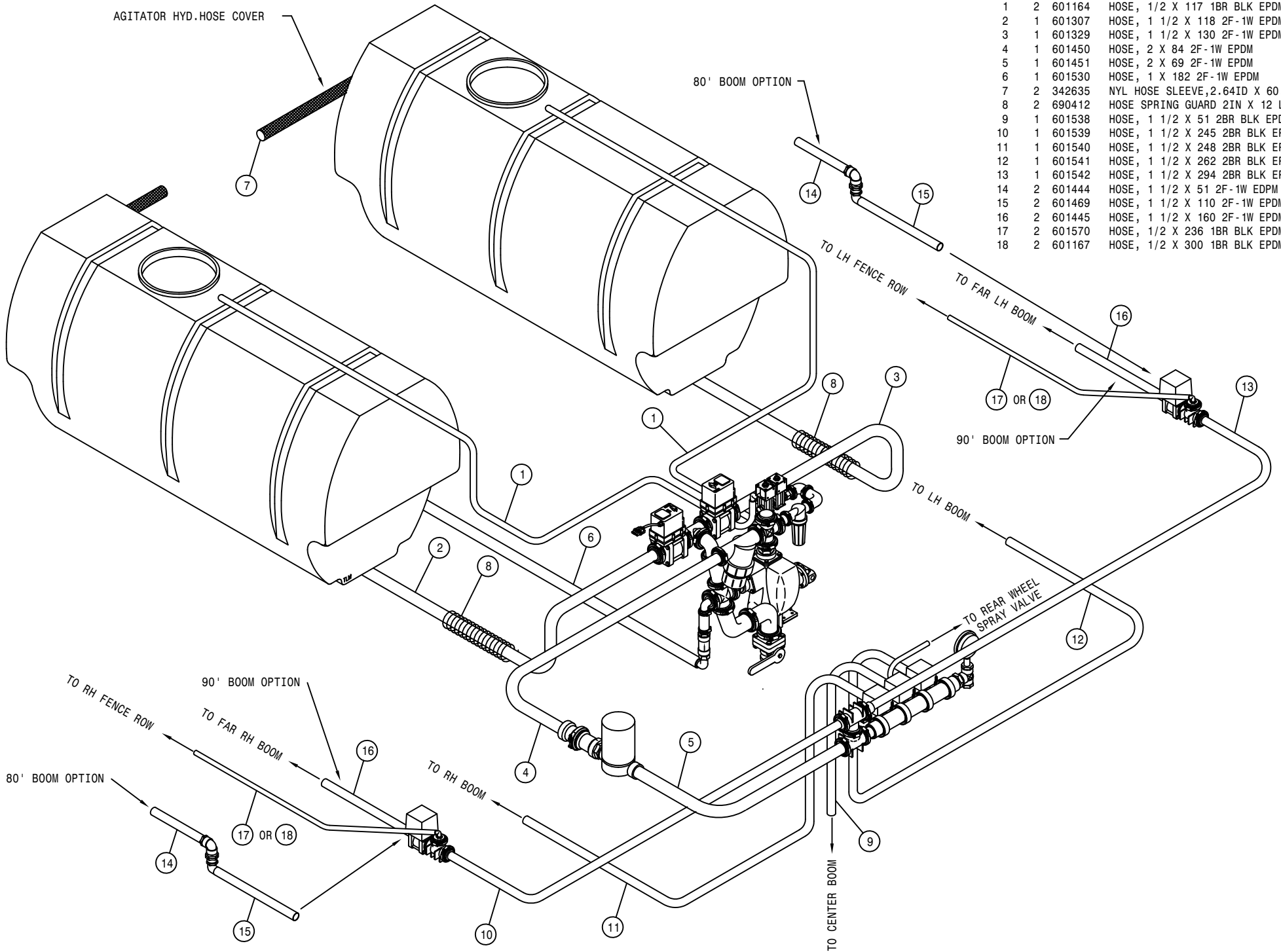

60' SOLUTION SOLENOID ASSEMBLY (HI-VOLUME)

DET. QTY PART NO. DESCRIPTION

1	1	164422	SOLU MANIF VLV MT, HIVOL
2	3	520067	HOSE CLAMP NO 28 STAINLESS
3	2	470136	3/8UNC-3 1/16ID-3 SQ U-BOLT
4	3	500153	2" FLANGE-90-1 1/2 HBARB POLY
5	2	500154	2" FLANGE-2" HOSE BARB POLY
6	5	500157	1" FLANGE GASKET EPDM
7	10	500158	1 1/2" GASKET FOR 2" FLANGE
8	5	500159	1" FLANGE CLAMP, S.S.
9	10	500160	2" FLANGE CLAMP, S.S.
10	3	500161	2"FLANGE-1"FLANGE COUPLER,POLY
11	4	914004	3/8UNC HEX STOVER NUT
12	1	500180	2"FLANGE-90-2"FLANGE LBO POLY
13	1	500181	2" FLANGE PLUG W/1/4"FNPT POLY
14	1	690359	PRESSURE GA GLYCERI 100 PSI
15	1	696178	ELECT 3-BALL VLV,2"FLANGE TJET
16	3	696502	OUTLET FLG END-CAP FOR 696178
17	2	696503	O-RING,VLV FITTING FOR 696178
18	2	696504	CLAMP,VLV FITTING FOR 696178
19	3	520141	2.31/2.62 T-BOLT HOSE CLAMP SS
20	1	500058	2"NPT X 2" H BARB, POLY
21	1	601450	HOSE, 2 X 84 2F-1W EPDM
22	2	520056	HOSE CLAMP NO 56 STAINLESS
23	2	470118	1/4UNC X 3/4 FLANGE HEX BOLT
24	1	690529	RFM 100 FLOW METER, RAVEN
25	1	601451	HOSE, 2 X 69 2F-1W EPDM
26	3	696501	FLANGE VLV TEE FOR 696178
27	3	900064	5/16UNC X 3/4 HEX BOLT
28	3	914002	5/16UNC HEX STOVER NUT
29	3	696500	450EC VLV W/FLG TEE FOR 696178
30	1	500119	1/2"NPT BR TEE-1/2"HBARB, POLY
31	1	500151	2" FLANGE TEE POLY
32	1	500175	1" FLANGE TEE POLY
33	1	500224	2" FLANGE PLUG W/1/4"FNPT POLY
34	1	500226	1" FLANGE PLUG W/1/4"FNPT POLY
35	1	618556	1/4NPT-90-1/2 HOSE BARB,POLY
36	3	520070	HOSE CLAMP NO 8 STAINLESS
37	1	500152	2" FLANGE-2" MNPT ADPTR POLY
38	1	690535	CONTROL VALVE,1 1/2"POLY,RAVN
39	2	470121	1/4UNC HEX FLANGE LOCK NUT

NOTE: ITEMS MARKED WITH A (\*) ARE SOLUTION VALVE REPAIR PARTS.

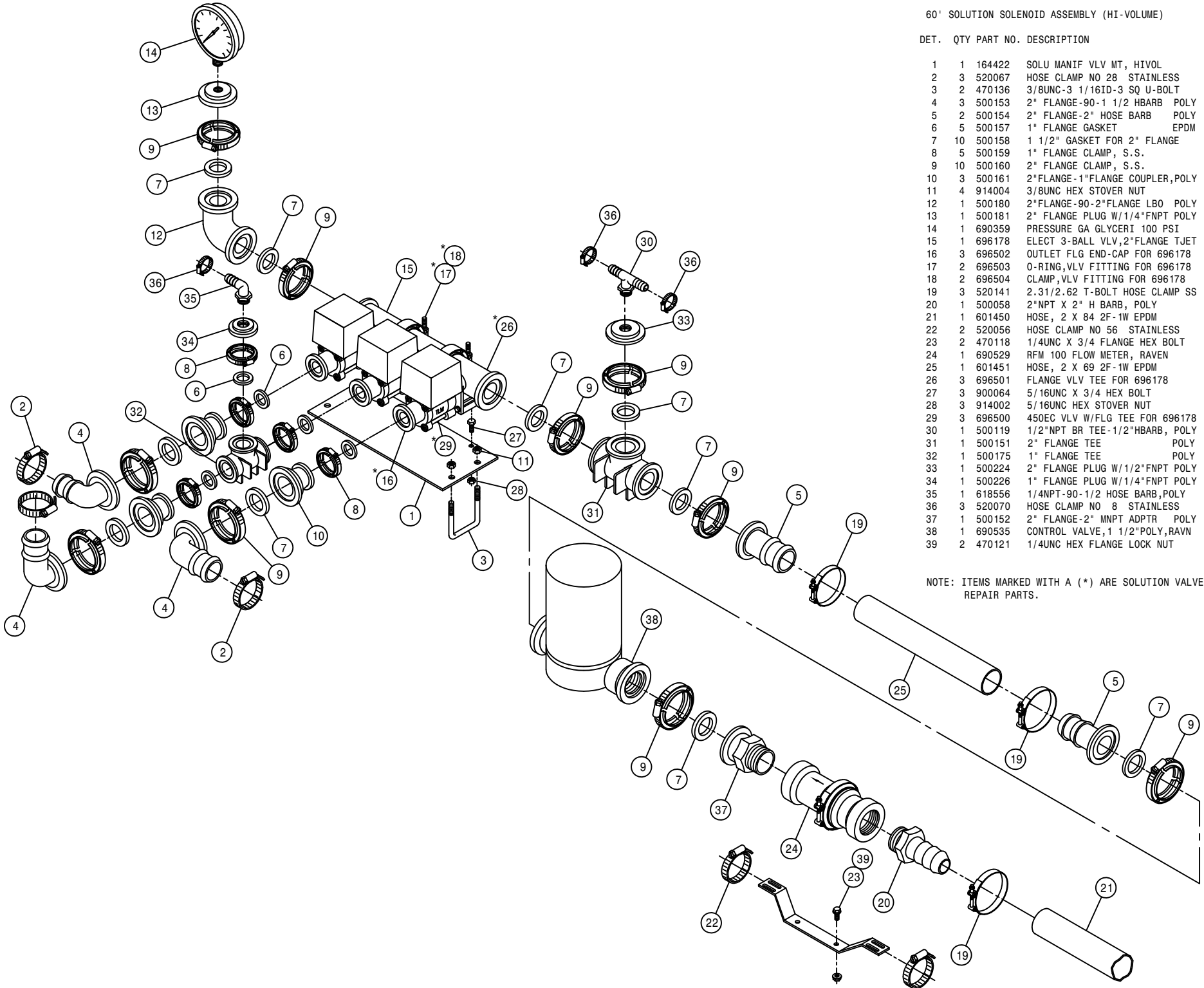

80'-90' SOLUTION SOLENOID ASSEMBLY (HI-VOLUME)

DET. QTY PART NO. DESCRIPTION

1	1	164422	SOLU MANIF VLV MT, HIVOL
2	5	520067	HOSE CLAMP NO 28 STAINLESS
3	2	500151	2" FLANGE TEE POLY
4	3	500153	2" FLANGE-90-1 1/2 HBARB POLY
5	2	500154	2" FLANGE-2" HOSE BARB POLY
6	5	500157	1" FLANGE GASKET EPDM
7	12	500158	1 1/2" GASKET FOR 2" FLANGE
8	5	500159	1" FLANGE CLAMP, S.S.
9	12	500160	2" FLANGE CLAMP, S.S.
10	3	500161	2"FLANGE-1"FLANGE COUPLER,POLY
11	2	500162	2" FLANGE-1 1/2 HOSE BARB POLY
12	1	500180	2"FLANGE-90-2"FLANGE LBO POLY
13	1	500181	2" FLANGE PLUG W/1/4"FNPT POLY
14	1	690359	PRESSURE GA GLYCERI 100 PSI
15	1	696178	ELECT 3-BALL VLV,2"FLANGE TJET
16	3	696502	OUTLET FLG END-CAP FOR 696178
17	2	696503	O-RING,VLV FITTING FOR 696178
18	2	696504	CLAMP,VLV FITTING FOR 696178
19	3	520141	2.31/2.62 T-BOLT HOSE CLAMP SS
20	1	500058	2"NPT X 2" H BARB, POLY
21	1	601450	HOSE, 2 X 84 2F-1W EPDM
22	2	520056	HOSE CLAMP NO 56 STAINLESS
23	2	470118	1/4UNC X 3/4 FLANGE HEX BOLT
24	1	690529	RFM 100 FLOW METER, RAVEN
25	1	601451	HOSE, 2 X 69 2F-1W EPDM
26	2	470136	3/8UNC-3 1/16ID-3 SQ U-BOLT
27	4	914004	3/8UNC HEX STOVER NUT
28	3	696501	FLANGE VLV TEE FOR 696178
29	3	900064	5/16UNC X 3/4 HEX BOLT
30	3	914002	5/16UNC HEX STOVER NUT
31	3	696500	450EC VLV W/FLG TEE FOR 696178
32	1	500175	1" FLANGE TEE POLY
33	1	500226	1" FLANGE PLUG W/1/4"FNPT POLY
34	1	618556	1/4NPT-90-1/2 HOSE BARB,POLY
35	1	520070	HOSE CLAMP NO 8 STAINLESS
36	1	500152	2" FLANGE-2" MNPT ADPTR POLY
37	1	690535	CONTROL VALVE,1 1/2"POLY,RAVN
38	2	470121	1/4UNC HEX FLANGE LOCK NUT

NOTE: ITEMS MARKED WITH A (\*) ARE SOLUTION VALVE REPAIR PARTS.

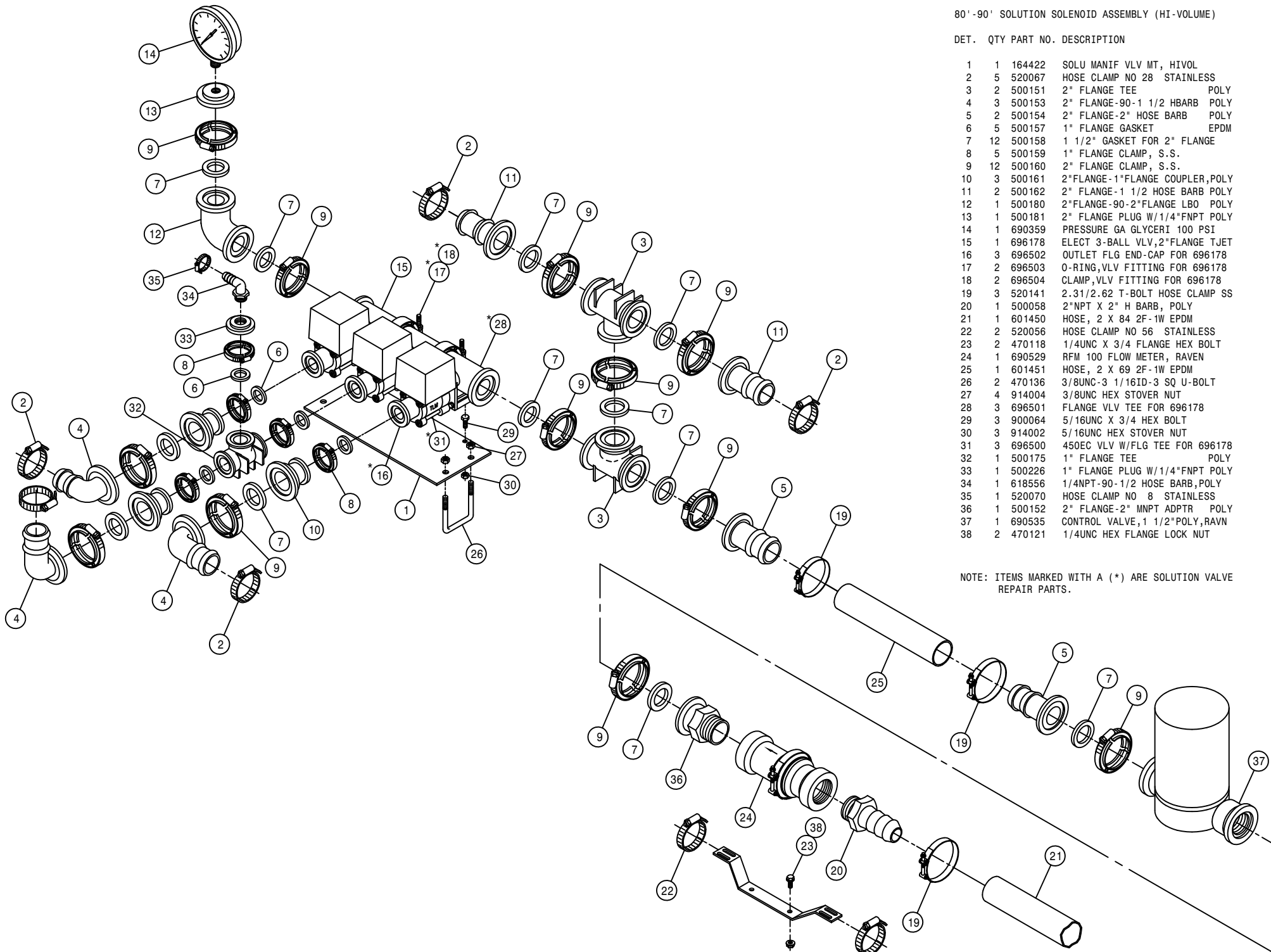

80' BOOM SWIVEL ASSEMBLY

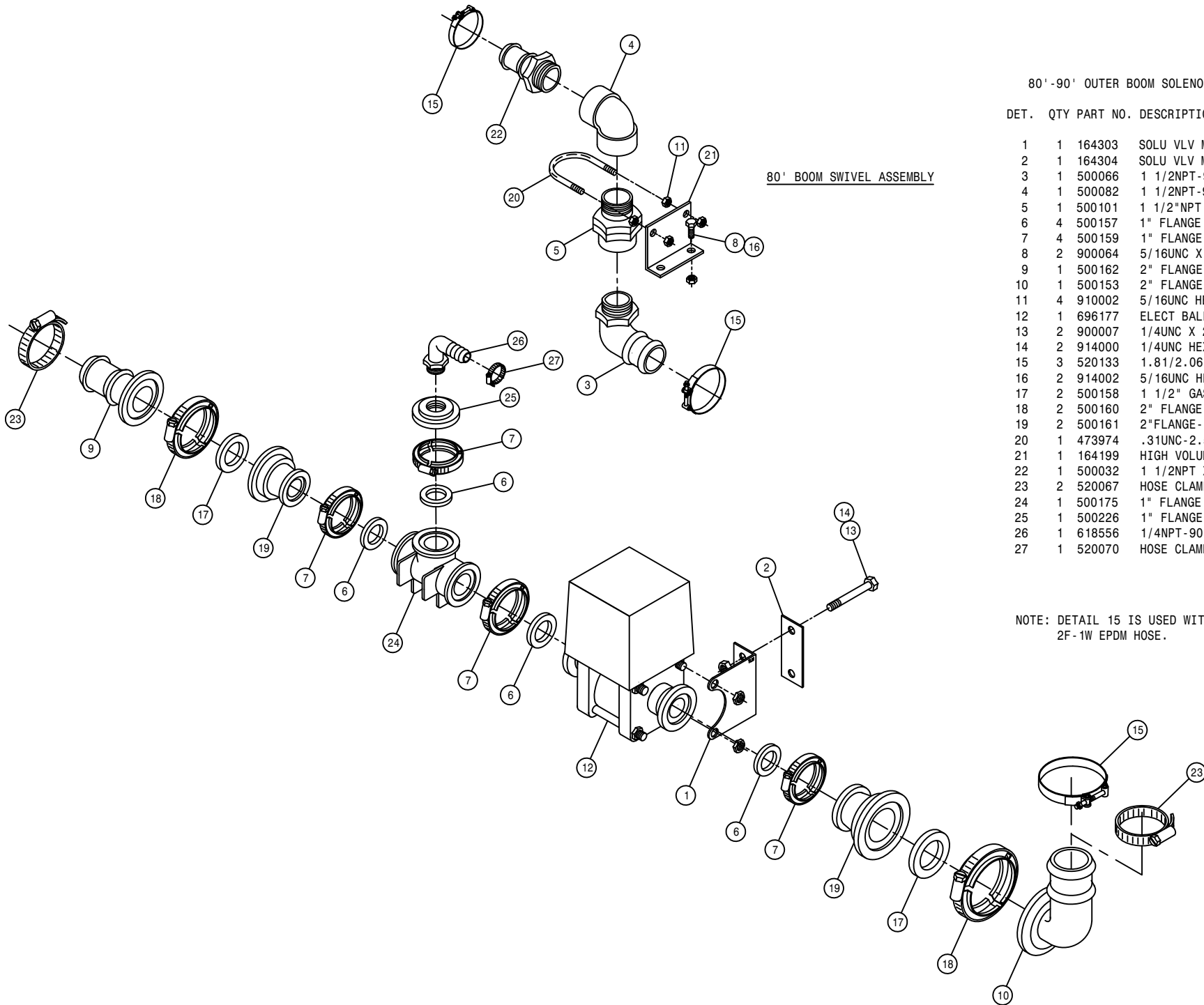

80'-90' OUTER BOOM SOLENOID (HI-VOLUME)

DET.	QTY	PART NO.	DESCRIPTION	
1	1	164303	SOLU VLV MT	97
2	1	164304	SOLU VLV MT KEEPER	97
3	1	500066	1 1/2NPT-90-1 1/2 H BARB POLY	
4	1	500082	1 1/2NPT-90 EL, POLY	
5	1	500101	1 1/2" NPT SWIVEL	POLY
6	4	500157	1" FLANGE GASKET	EPDM
7	4	500159	1" FLANGE CLAMP, S.S.	
8	2	900064	5/16UNC X 3/4 HEX BOLT	
9	1	500162	2" FLANGE-1 1/2 HOSE BARB POLY	
10	1	500153	2" FLANGE-90-1 1/2 HBARB POLY	
11	4	910002	5/16UNC HEX NUT	
12	1	696177	ELECT BALL VLV, 1" FLANGE	TJET
13	2	900007	1/4UNC X 2" HEX BOLT	
14	2	914000	1/4UNC HEX STOVER NUT	
15	3	520133	1.81/2.06 T-BOLT HOSE CLAMP SS	
16	2	914002	5/16UNC HEX STOVER NUT	
17	2	500158	1 1/2" GASKET FOR 2" FLANGE	
18	2	500160	2" FLANGE CLAMP, S.S.	
19	2	500161	2" FLANGE-1" FLANGE COUPLER, POLY	
20	1	473974	.31UNC-2.56ID-3.5 U-BOLT SS	
21	1	164199	HIGH VOLUME HOSE SWIVEL MT	
22	1	500032	1 1/2NPT X 1 1/2 H BARB, POLY	
23	2	520067	HOSE CLAMP NO 28 STAINLESS	
24	1	500175	1" FLANGE TEE	POLY
25	1	500226	1" FLANGE PLUG W/1/4" FNPT POLY	
26	1	618556	1/4NPT-90-1/2 HOSE BARB, POLY	
27	1	520070	HOSE CLAMP NO 8 STAINLESS	

NOTE: DETAIL 15 IS USED WITH 1 1/2 I.D. 2F-1W EPDM HOSE.

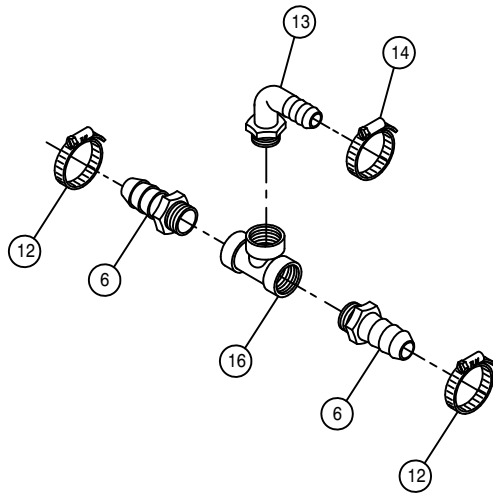

FEEDER TEE ASSEMBLY (STANDARD VOLUME)

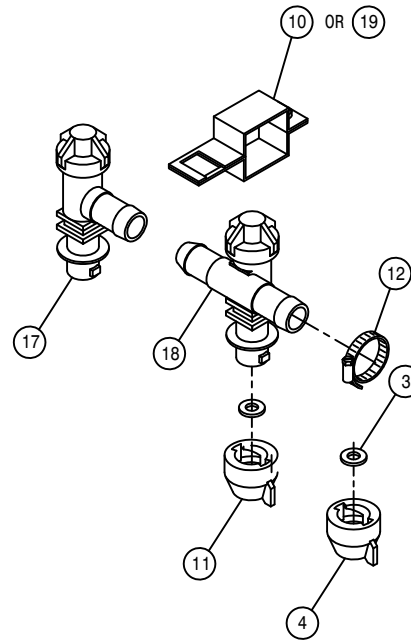

SINGLE TIP NOZZLE SPACING

**BOOM FEEDER TEE ASSEMBLY**

DET. QTY PART NO. DESCRIPTION

1	2	500108	1"NPT-3/4" HOSE BARB	POLY
2	1	500117	1"NPT-90-1 1/2"HOSE BARB, POLY	
3	4	737824	QUICK TEEJET SEAT GASKET	
4	2	737825	QUICK SHUT-OFF CAP	
5	1	520067	HOSE CLAMP NO 28	STAINLESS
6	2	500022	3/4NPT-3/4HOSE BARB, POLY	
7	1	500075	1" NPT PIPE TEE, POLY	
8	1	737833	QUICK TJET LBO,3-TIP BODY	.75
9	1	737834	QUICK TJET TEE,3-TIP BODY	.75
10	2	737817	NOZL MT CLMP,1.00 SQ SS,Q-TJET	
11	2	737822	CAP SET, YELLOW QUICK TEEJET	
12	6	520055	HOSE CLAMP NO 12	STAINLESS
13	1	500026	3/4NPT-90-1"HOSE BARB, POLY	
14	1	520090	HOSE CLAMP NO 16	STAINLESS
15	1	520133	1.81/2.06 T-BOLT HOSE CLAMP SS	
16	1	505218	3/4 NPT PIPE TEE, POLY	
17	1	737829	QUICK TJET LBO,1-TIP BODY	.75
18	1	737830	QUICK TJET TEE,1-TIP BODY	.75
19	2	737832	NOZL MT CLMP,1.25 SQ,SS Q-TJET	

NOTE: DETAIL 15 IS USED WITH 1 1/2 I.D.  
2F-1W EPDM HOSE.

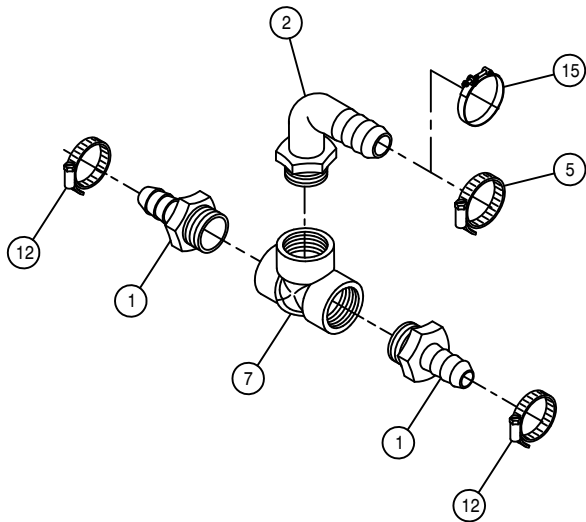

FEEDER TEE ASSEMBLY (HIGH VOLUME)

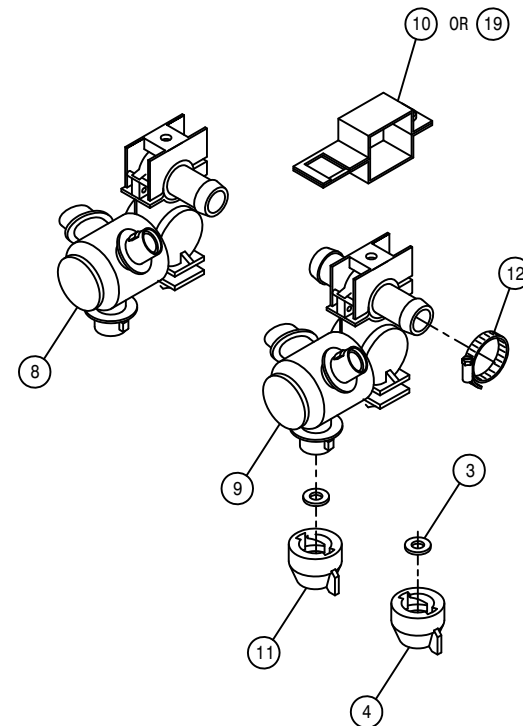

TRIPLE TIP NOZZLE SPACING

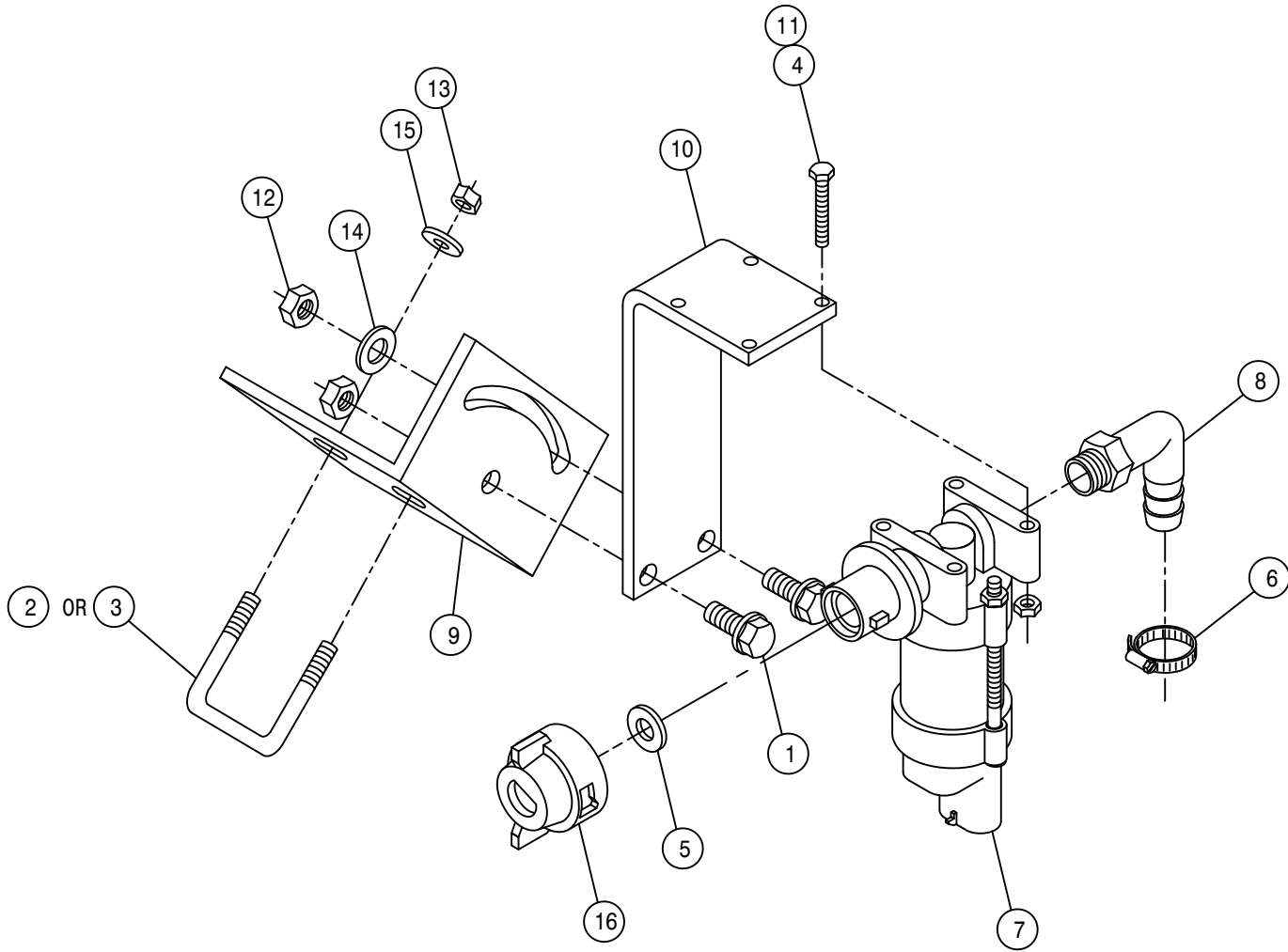

RIGHT FENCE ROW NOZZLE ASSEMBLY

DET.	QTY	PART NO.	DESCRIPTION
1	2	470118	1/4UNC X 3/4 FLANGE HEX BOLT
2	1	473973	.31UNC-1.31ID-2.0 SQ U-BOLT SS
3	1	473980	.31UNC-1.06ID-1.75SQ U-BOLT SS
4	4	473993	6-32 X 1 1/4 HH MACH SCR
5	1	737824	QUICK TEEJET SEAT GASKET
6	1	520070	HOSE CLAMP NO 8 STAINLESS
7	1	737875	NOZZLE BODY VALVE, 12VDC
8	1	618556	1/4NPT-90-1/2 HOSE BARB,POLY
9	1	737886	FENCE-ROW NOZZLE MT,284 01
10	1	737906	FENCE ROW NOZL BRKT
11	4	910022	6-32 HEX NUT
12	2	914000	1/4UNC HEX STOVER NUT
13	2	914002	5/16UNC HEX STOVER NUT
14	1	920000	1/4 SAE FLAT WASHER
15	2	920001	5/16 SAE FLAT WASHER
16	1	737822	CAP SET, YELLOW QUICK TEEJET



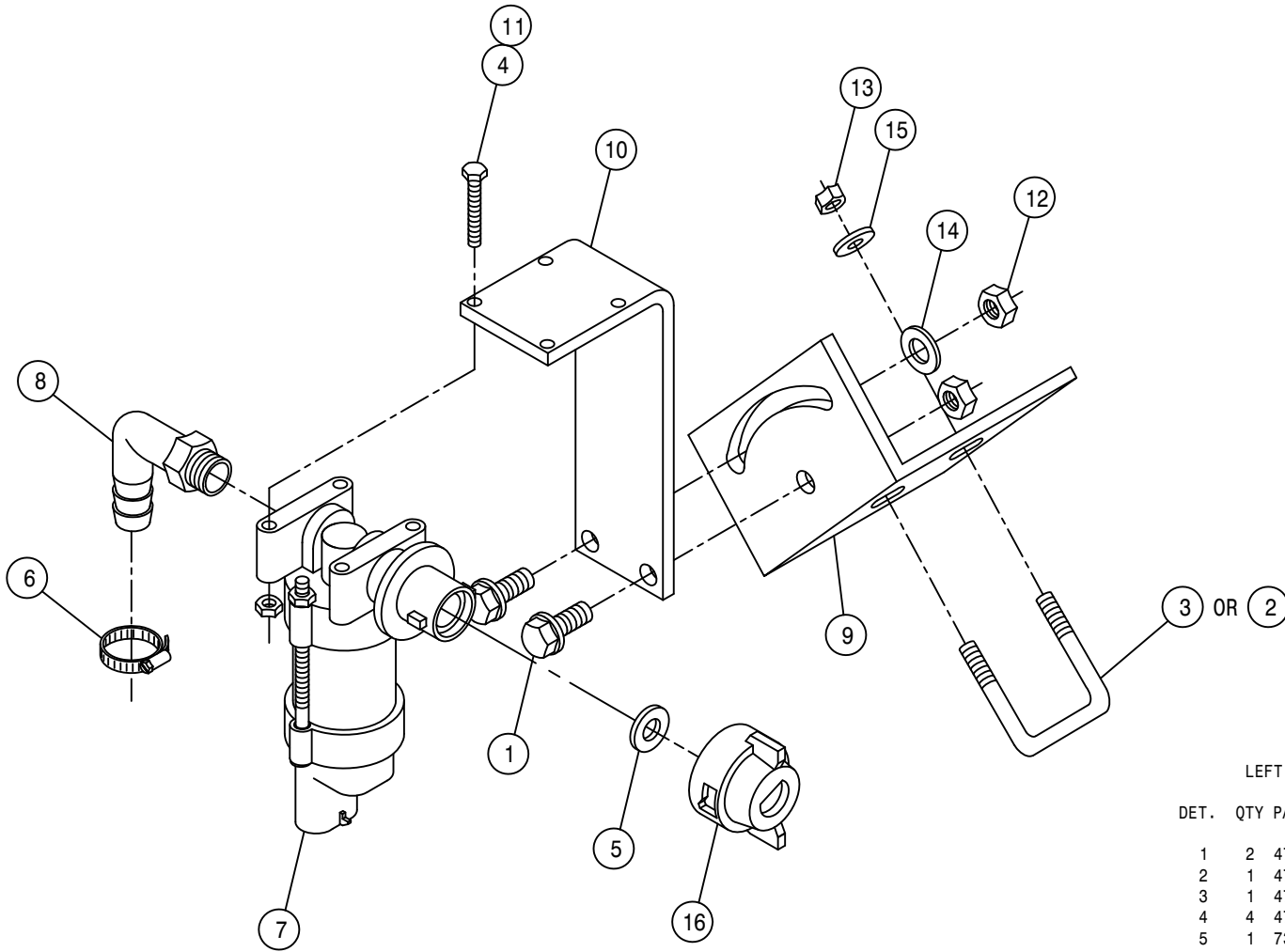

LEFT FENCE ROW NOZZLE ASSEMBLY

DET.	QTY	PART NO.	DESCRIPTION
1	2	470118	1/4UNC X 3/4 FLANGE HEX BOLT
2	1	473973	.31UNC-1.31ID-2.0 SQ U-BOLT SS
3	1	473980	.31UNC-1.06ID-1.75SQ U-BOLT SS
4	4	473993	6-32 X 1 1/4 HH MACH SCR
5	1	737824	QUICK TEEJET SEAT GASKET
6	1	520070	HOSE CLAMP NO 8 STAINLESS
7	1	737875	NOZZLE BODY VALVE, 12VDC
8	1	618556	1/4NPT-90-1/2 HOSE BARB,POLY
9	1	737886	FENCE-ROW NOZZLE MT,284 01
10	1	737906	FENCE ROW NOZL BRKT
11	4	910022	6-32 HEX NUT
12	2	914000	1/4UNC HEX STOVER NUT
13	2	914002	5/16UNC HEX STOVER NUT
14	1	920000	1/4 SAE FLAT WASHER
15	2	920001	5/16 SAE FLAT WASHER
16	1	737822	CAP SET, YELLOW QUICK TEEJET

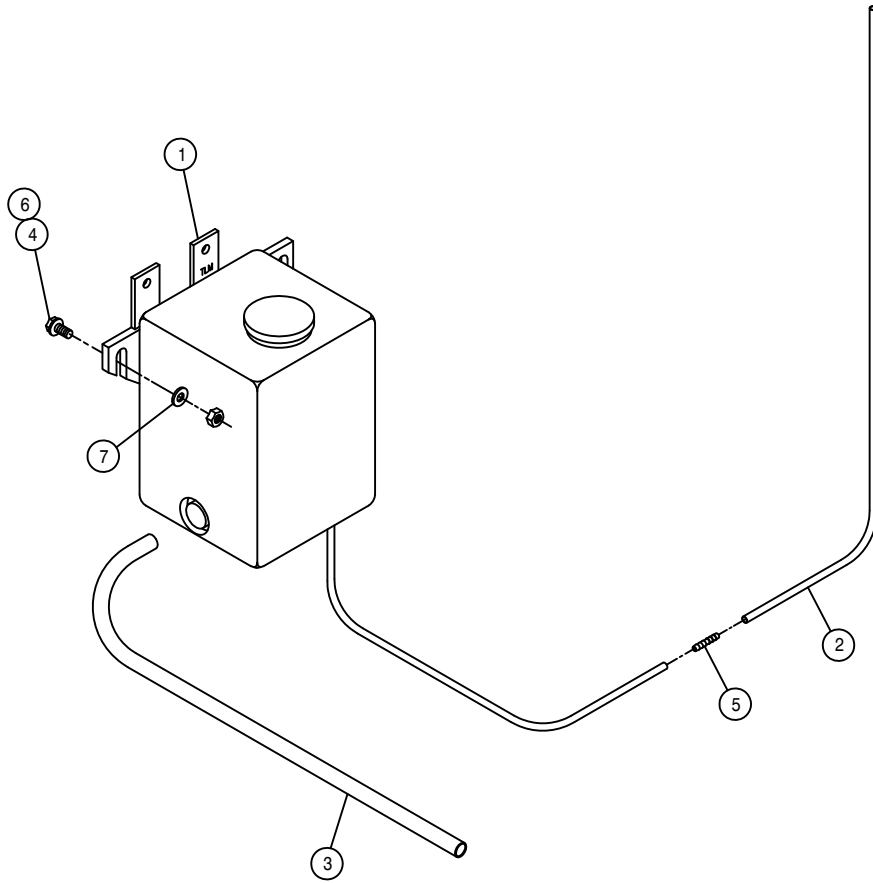

WINDSHIELD WASHER ASSEMBLY

DET. QTY PART NO. DESCRIPTION

1	1	290002	WINDSHIELD WASHER KIT
2	14	195913	7/64" WINDSHIELD WASHER HOSE
3	13	299110	.35 ID WIRE FLEX GUARD
4	3	470231	1/4UNC X 1" FLANGE HEX BOLT
5	1	711033	3/16-1/8 HOSE BARB REDU UNION
6	3	914000	1/4UNC HEX STOVER NUT
7	3	920000	1/4 SAE FLAT WASHER

BOOM CONTROL VALVE ASSEMBLY

DET. QTY PART NO. DESCRIPTION

1	28	473802	# 8 INT TOOTH STAR WASHER
2	1	605615	HYD FILTER, INLINE 25M 9/16FOR
3	1	606102	BOOM VLV, X11/284/2100 PWRSYS03
4	1	618115	9/16MJIC-90-3/4MOR LBO
5	5	618119	9/16MJIC-90-9/16MOR LBO
6	5	618126	9/16MJIC-9/16MOR ADPTR
7	1	618241	3/4MJIC-90-3/4MOR LBO
8	3	618444	9/16MOR RUN TEE-9/16MJIC
9	2	618618	9/16MJIC-90-9/16FJIC SWIV LBO
10	1	618692	3/4FJIC SWIV-9/16MOR ADPTR
11	1	605616	ELEMENT, 25M HYD FILTER 605615
12	1	605617	SPRING KIT, HYD FILTER 605615
13	2	900146	3/8UNC X 5 3/4 HEX BOLT
14	2	914004	3/8UNC HEX STOVER NUT
15	1	618486	9/16FJIC SW RUN TEE-9/16MJIC
16	2	614763	9/16MJIC-9/16MOR, .042 CHK ADPTR

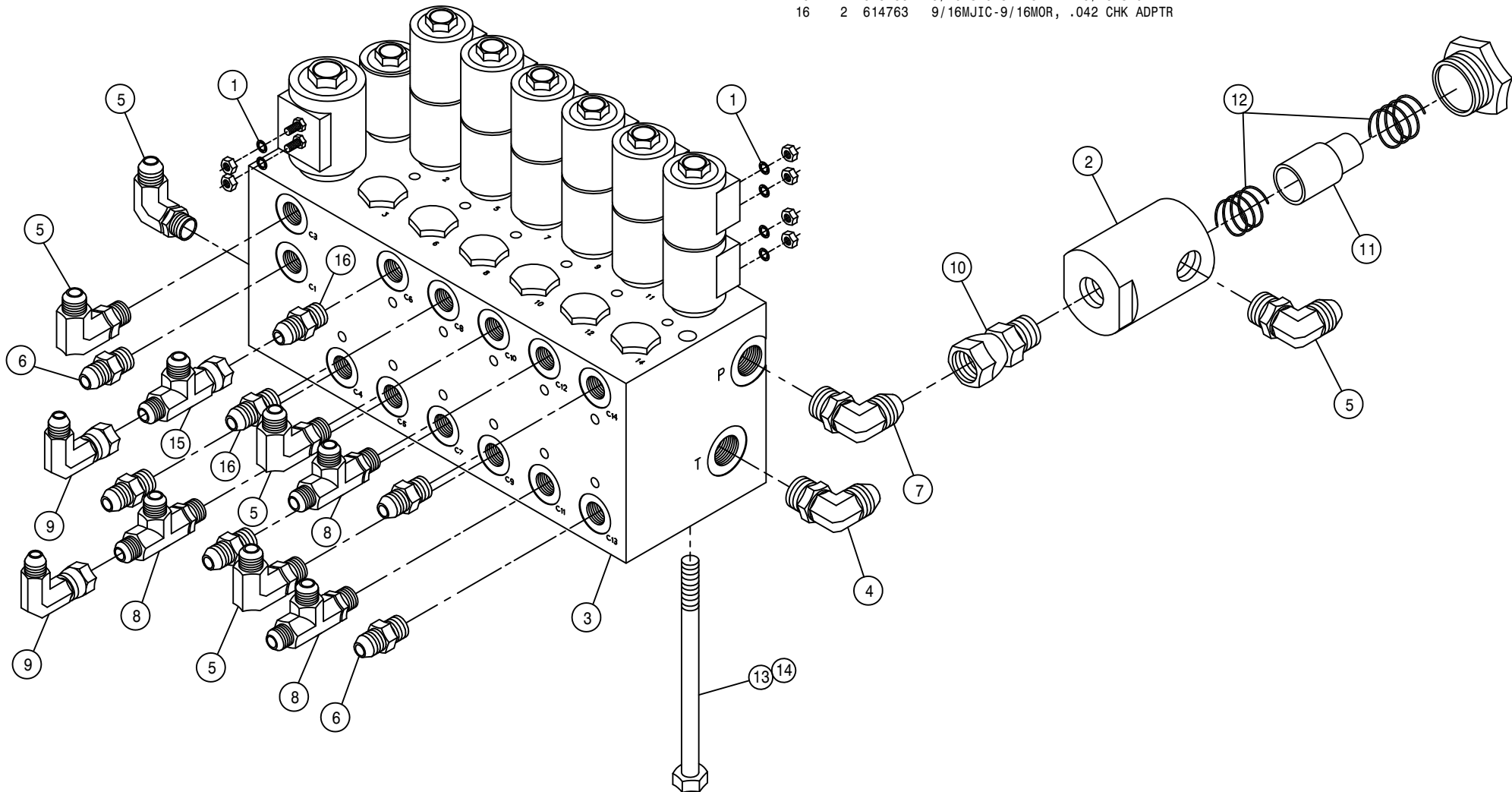

LIFTARM ASSEMBLY

DET. QTY PART NO. DESCRIPTION

DET.	QTY	PART NO.	DESCRIPTION
1	2	160471	LWR LIFT ARM WLD 8540-8250 87
2	1	164685	RH LIFT ARM MT WLD, 284XP 2001
3	1	164686	LH LIFT ARM MT WLD, 284XP 2001
4	12	160691	BUSH LIFT ARM LONG 470
5	12	470287	TUBE CLAMP, .375-.375 (PAIR)
6	1	164651	UPPER LIFT ARM WLD,284 2001
7	12	471005	1/4 28 X 1/2 GREASE ZERK
8	3	900013	1/4UNC X 3 3/4 HEX BOLT
9	2	621207	TRANSOM LIFT CYL ASSY 284-2101
10	3	914000	1/4UNC HEX STOVER NUT
11	10	900334	5/8UNC X 1 3/4 HEX BOLT
12	4	900342	5/8UNC X 4" HEX BOLT
13	8	900343	5/8UNC X 4 1/2 HEX BOLT
14	30	914010	5/8UNC HEX STOVER NUT
15	1	615761	LIFT RAISE HYD TUBE ASSY
16	1	615762	LIFT LOWER HYD TUBE ASSY
17	1	615764	LEVEL LOWER HYD TUBE ASSY
18	1	615763	LEVEL RAISE HYD TUBE ASSY
19	1	615767	BOOM EXTN LOWER HYD TUBE ASSY
20	1	615766	BOOM EXTN RAISE HYD TUBE ASSY
21	1	615769	RH FOLD LOWER HYD TUBE ASSY
22	1	615768	RH FOLD RAISE HYD TUBE ASSY
23	6	619010	9/16MJIC UNION
24	8	900338	5/8UNC X 3" HEX BOLT
25	2	164684	LIFT ARM MT KEEPER WLD 284XP
26	2	618019	9/16MJIC UNION TEE
27	2	618618	9/16MJIC-90-9/16FJIC SWIV LBO

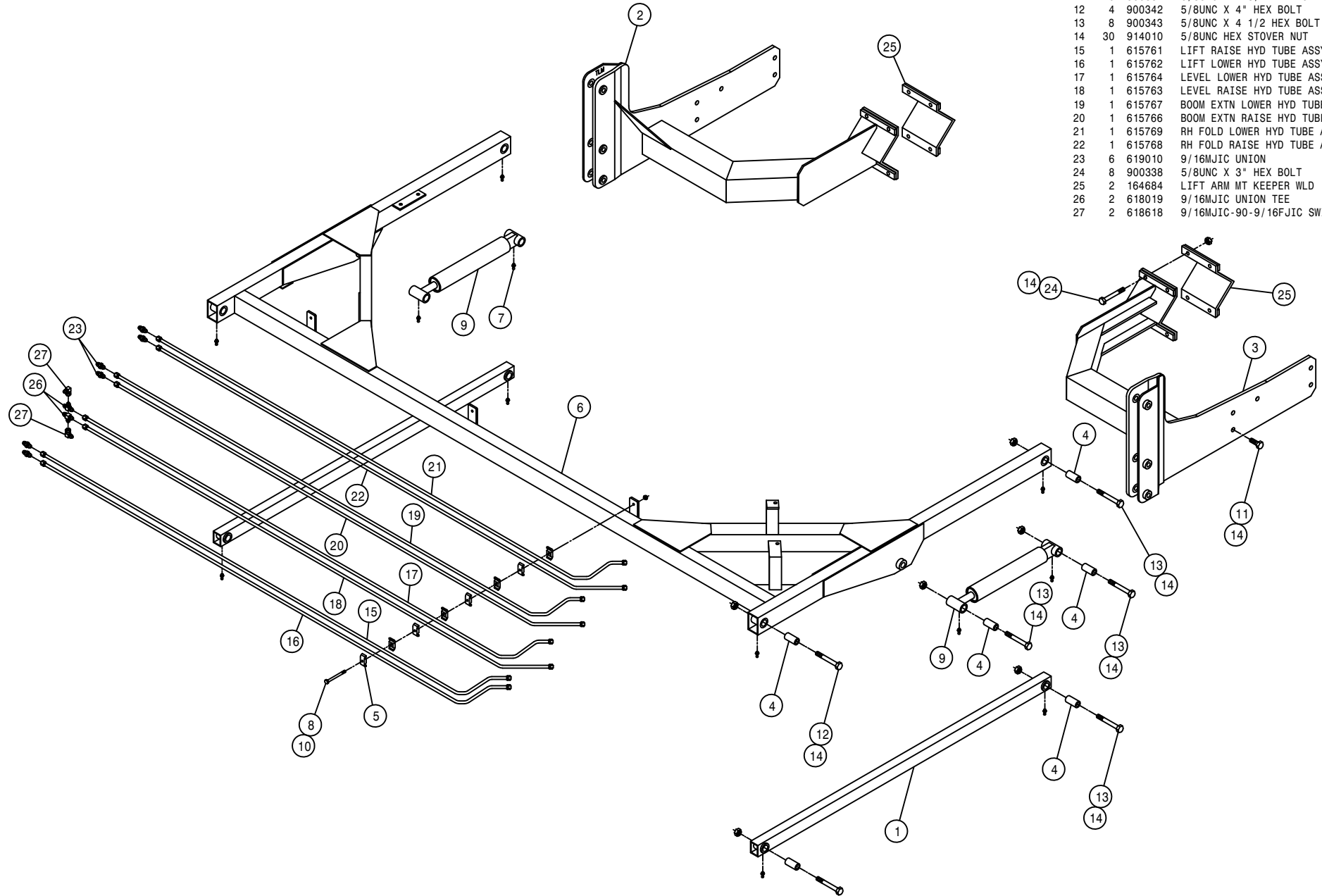

TRANSOM ASSEMBLY

DET. QTY PART NO. DESCRIPTION

DET.	QTY	PART NO.	DESCRIPTION	
1	2	160429	FEEDER HOSE SUPPORT SPRING MT	
2	4	160691	BUSH LIFT ARM LONG 470	
3	2	164123	NOZL MT TUBE, 254/284	96
4	2	164125	NOZL MT TUBE HANGER CHAN	96
5	2	164127	NOZL MT TUBE CLAMP	96
6	2	164128	LEVEL CYL PIVOT BRKT WLD	96
7	2	164315	BOOM BREAKAWAY WLD	97
8	2	900848	5/8UNC X 4 3/4 HEX BOLT GR8	
9	2	470136	3/8UNC-3 1/16ID-3 SQ U-BOLT	
10	4	164264	5/8UNC X 3" EYE BOLT	
11	6	471005	1/4 28 X 1/2 GREASE ZERK	
12	8	900007	1/4UNC X 2" HEX BOLT	
13	2	900849	5/8UNC X 4 1/2 HHCS,7/8THD GR8	
14	4	910010	5/8UNC HEX NUT	
15	8	914000	1/4UNC HEX STOVER NUT	
16	4	914004	3/8UNC HEX STOVER NUT	
17	1	164308	TRANSOM WLD, 284	97
18	12	914010	5/8UNC HEX STOVER NUT	
19	8	920005	5/8 SAE FLAT WASHER	
20	4	920006	3/4 SAE FLAT WASHER	
21	2	164230	BOOM PIVOT PIN, .75 X 13.31	96
22	4	470162	COTTER PIN 3/16 X 1 1/2 SQ CUT	
23	2	482000	SPRING, .930D X 8.5LG, .072WIRE	
24	2	520126	CUSH HOSE CLAMP 2IN X 5/8W	
25	2	621210	BOOM LEVEL CYL ASSY	04
26	2	621208	BOOM HINGE FOLD CYL ASSY	04
27	4	900829	5/8UNC X 4" HEX BOLT GR8	
28	2	900844	5/8UNC X 2 3/4 HEX BOLT GR8	
29	2	471023	GREASE ZERK 1/4-28 X 45	
30	4	520099	HOSE CLAMP NO 40 STAINLESS	
31	2	621211	ACCUMULATOR CYL ASSY,60 BOOM	
32	2	621212	ACCUMULATOR CYL ASSY,80/90BOOM	
33	4	629735	CAPLUG, 1 1/4" SQ, BLACK POLY	
34	2	470118	1/4UNC X 3/4 FLANGE HEX BOLT	
35	2	470121	1/4UNC HEX FLANGE LOCK NUT	

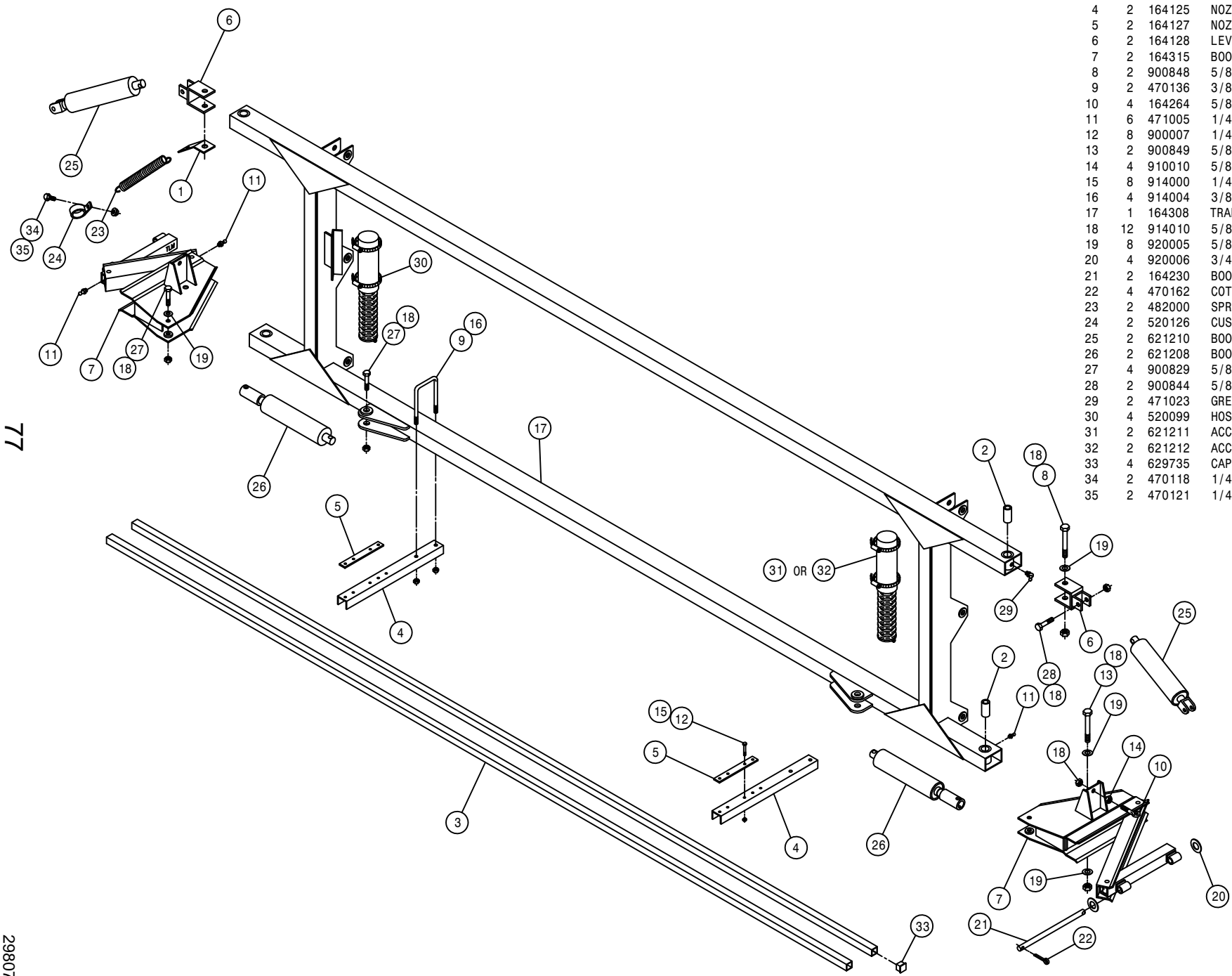

77

298077

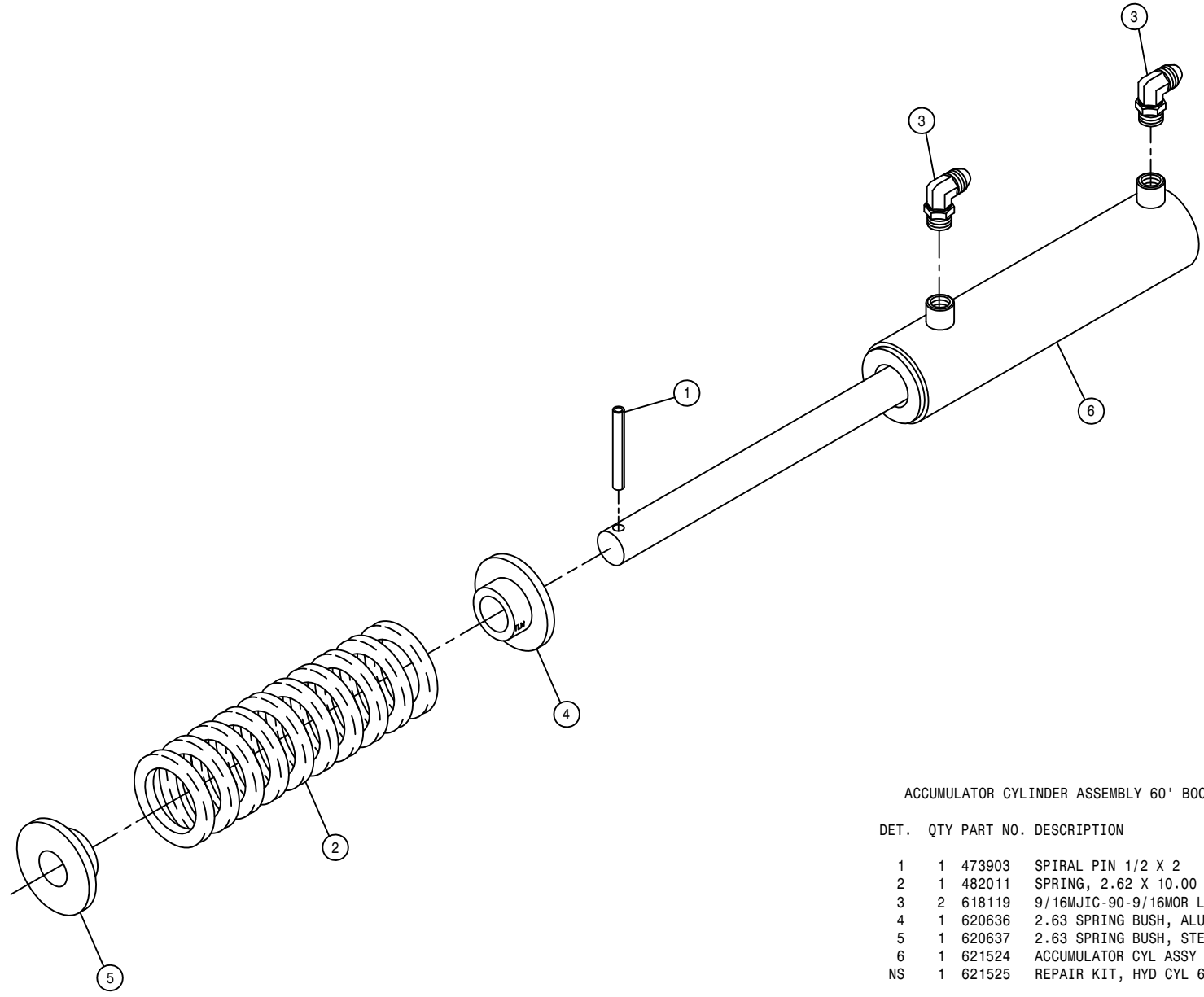

ACCUMULATOR CYLINDER ASSEMBLY 60' BOOM

DET.	QTY	PART NO.	DESCRIPTION	
	1	473903	SPIRAL PIN 1/2 X 2	640
	1	482011	SPRING, 2.62 X 10.00 COMPRSN	
	2	618119	9/16MJC-90-9/16MOR LBO	
	4	620636	2.63 SPRING BUSH, ALUM	96
	5	620637	2.63 SPRING BUSH, STEEL	96
	6	621524	ACCUMULATOR CYL ASSY	
NS	1	621525	REPAIR KIT, HYD CYL 621524	

NOTE: 621211 - ACCUMULATOR CYLINDER ASSEMBLY

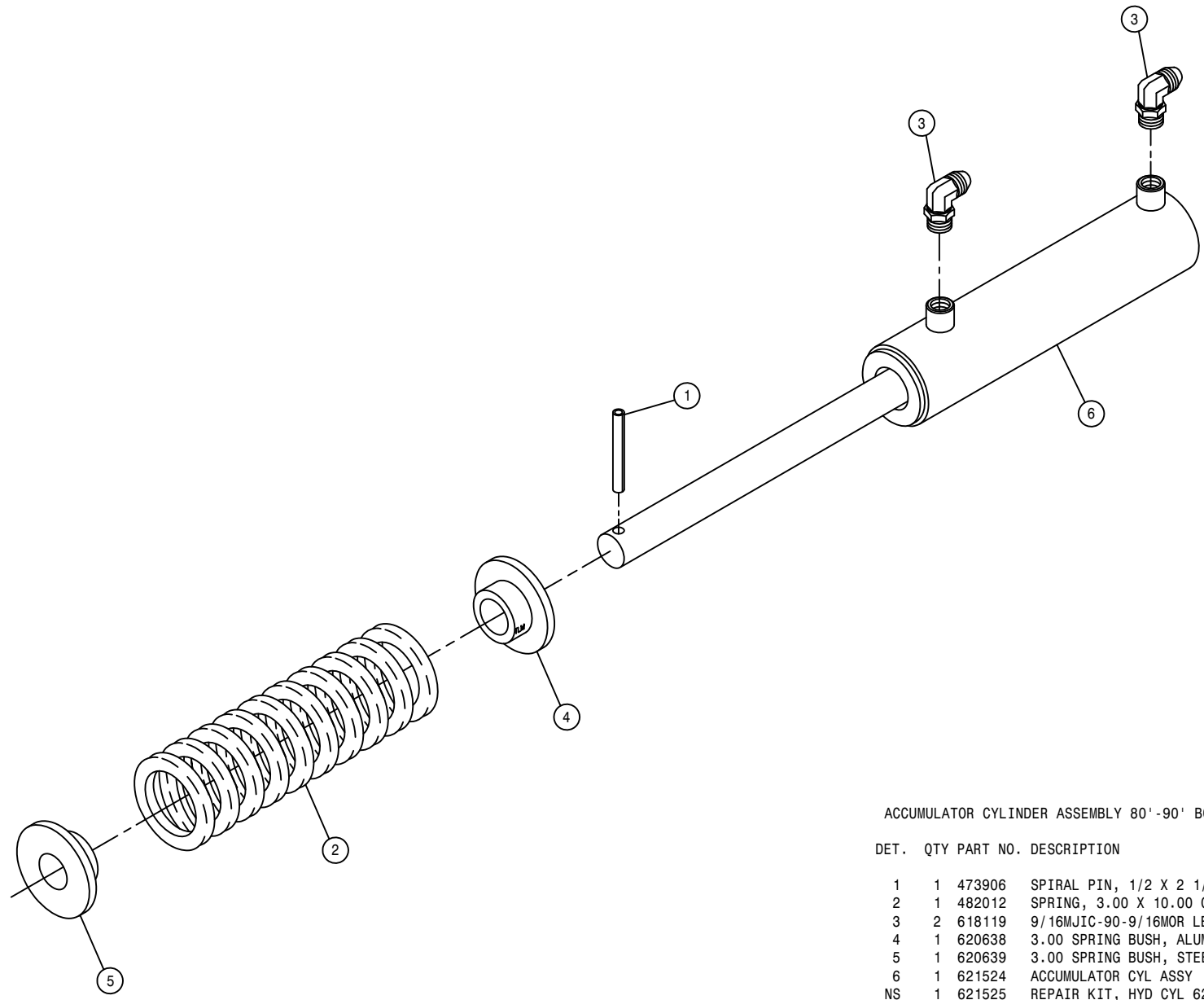

ACCUMULATOR CYLINDER ASSEMBLY 80'-90' BOOM

DET.	QTY	PART NO.	DESCRIPTION
	1	473906	SPIRAL PIN, 1/2 X 2 1/2 LG
	1	482012	SPRING, 3.00 X 10.00 COMPRSN
	2	618119	9/16MJIC-90-9/16MOR LBO
	1	620638	3.00 SPRING BUSH, ALUM 96
	1	620639	3.00 SPRING BUSH, STEEL 96
	1	621524	ACCUMULATOR CYL ASSY
NS	1	621525	REPAIR KIT, HYD CYL 621524

NOTE: 621212 - ACCUMULATOR CYLINDER ASSEMBLY

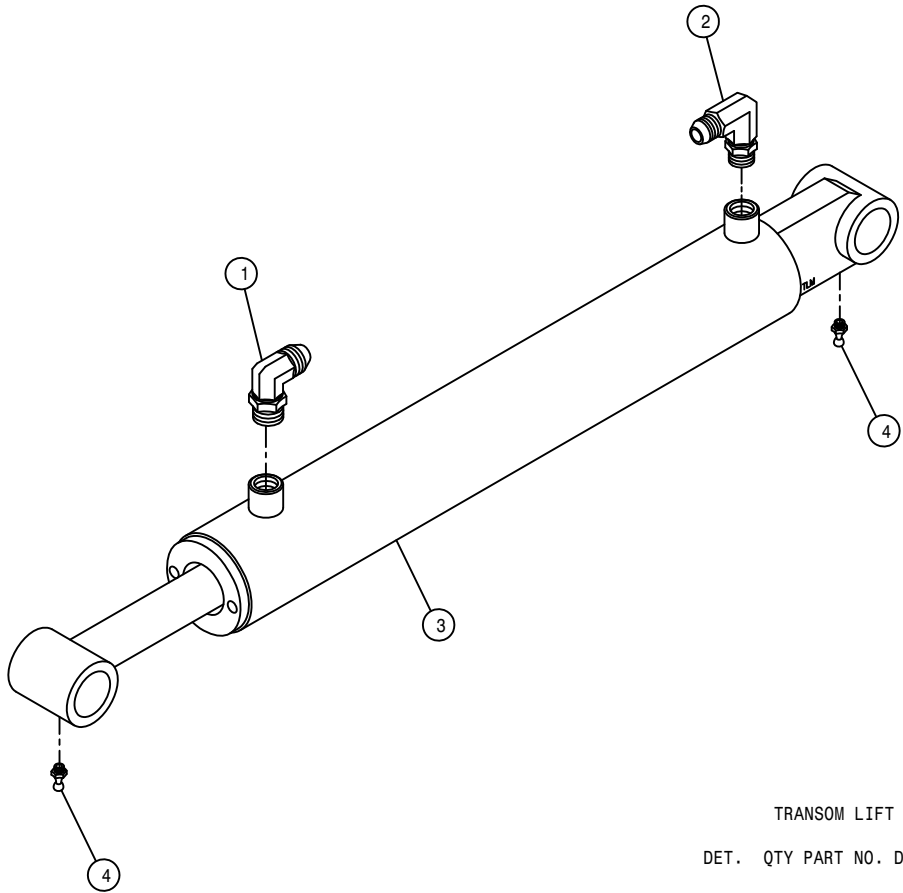

TRANSOM LIFT CYLINDER ASSEMBLY

DET.	QTY	PART NO.	DESCRIPTION
	1	618119	9/16MJIC-90-9/16MOR LBO
	1	618689	9/16MOR-90-9/16MJ .042 CHK VLV
	1	621518	TRANSOM LIFT CYL ASSY
	4	471005	1/4 28 X 1/2 GREASE ZERK
	NS	621519	REPAIR KIT, HYD CYL 621518

NOTE: 621207 - TRANSOM LIFT CYLINDER ASSEMBLY WITH FITTINGS



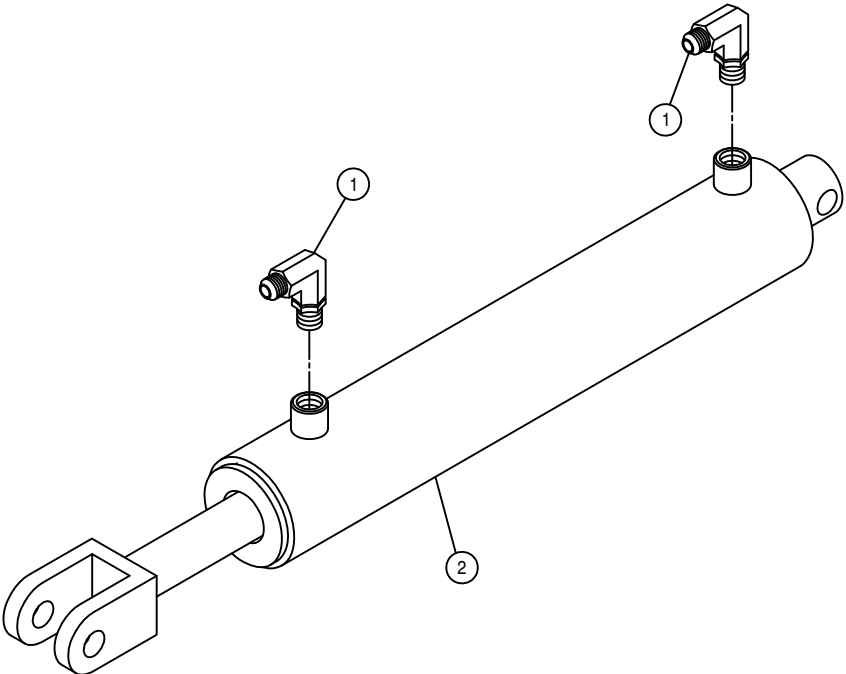

BOOM LEVEL CYLINDER ASSEMBLY

DET. QTY PART NO. DESCRIPTION

1	2	618119	9/16MJIC-90-9/16MOR LBO
2	1	621522	BOOM LEVEL CYL ASSY
NS	1	621523	REPAIR KIT, HYD CYL 621522

NOTE: 621210 - BOOM LEVEL CYLINDER ASSEMBLY WITH FITTINGS

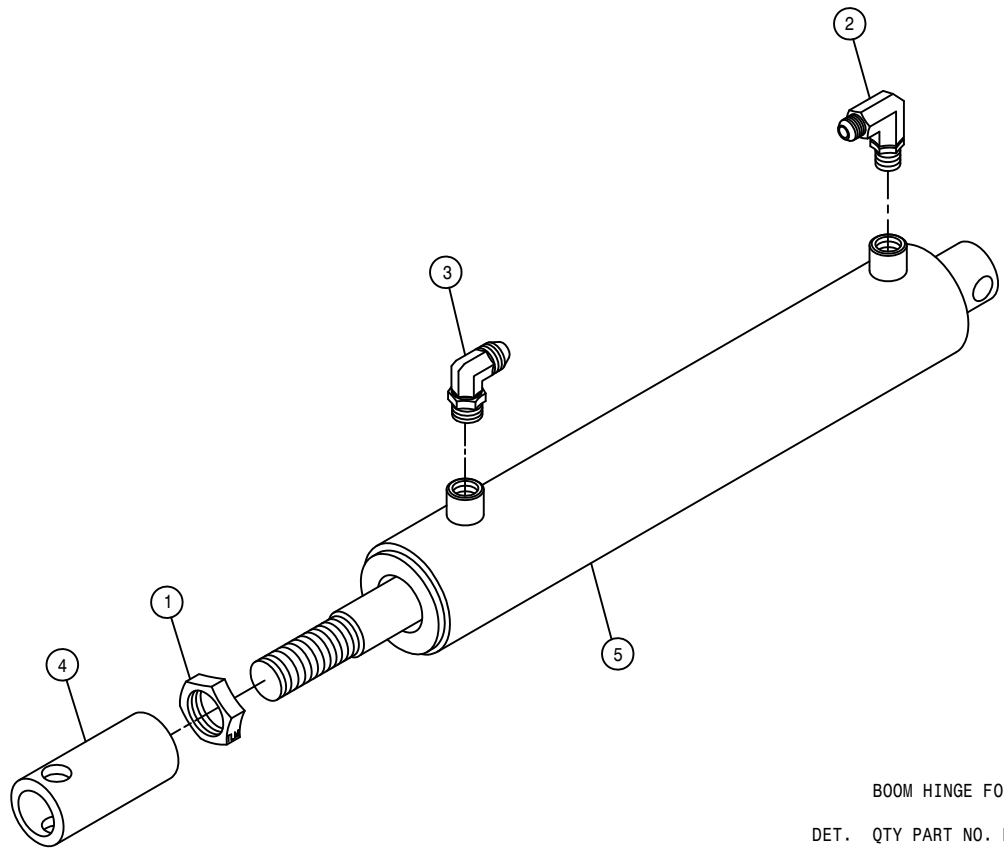

BOOM HINGE FOLD CYLINDER ASSEMBLY

DET.	QTY	PART NO.	DESCRIPTION
	1	472322	7/8-14 UNF HEX JAM NUT
	1	614750	.042 ELBOW ASSY,9/16MOR 90D
	1	618688	9/16MOR-90-9/16MJ .025 CHK VLV
	1	620653	FOLD CYL ADJ SLEEVE 97
	1	621520	BOOM HINGE FOLD CYL ASSY
NS	1	621521	REPAIR KIT, HYD CYL 621520

NOTE: 621208 - BOOM HINGE FOLD CYLINDER ASSEMBLY WITH FITTINGS

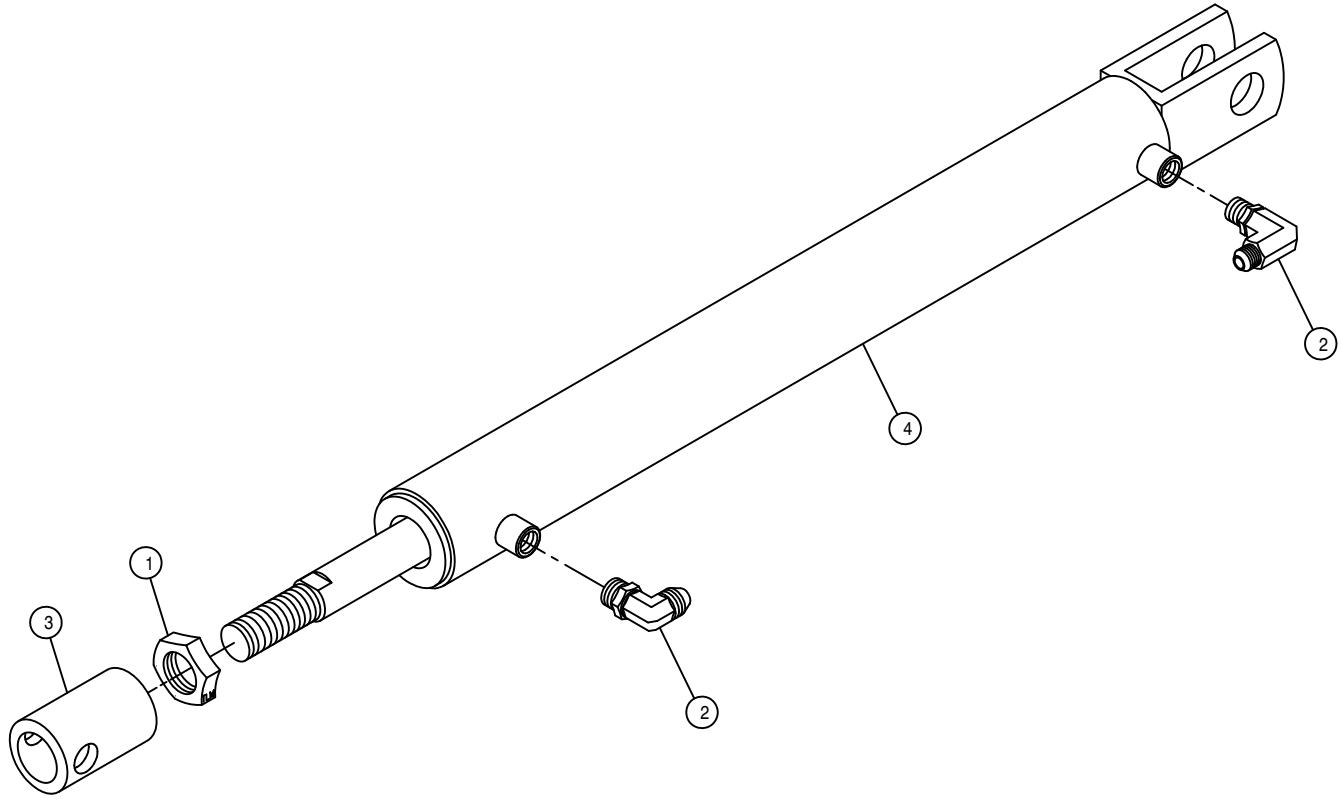

BOOM CENTER SECTION FOLD CYLINDER ASSEMBLY

DET.	QTY	PART NO.	DESCRIPTION
	1	472328	1" - 12 HEX JAM NUT
	2	614750	.042 ELBOW ASSY, 9/16MOR 90D
	3	620681	CENTER FOLD CYL ADJ SLEEVE 12T
	4	621526	BOOM CNTR SECT CYL ASSY (12T)
	NS	1 621527	REPAIR KIT, HYD CYL 621526

NOTE: 621213 - BOOM CNTR SECT FOLD CYLINDER ASSEMBLY WITH FITTINGS

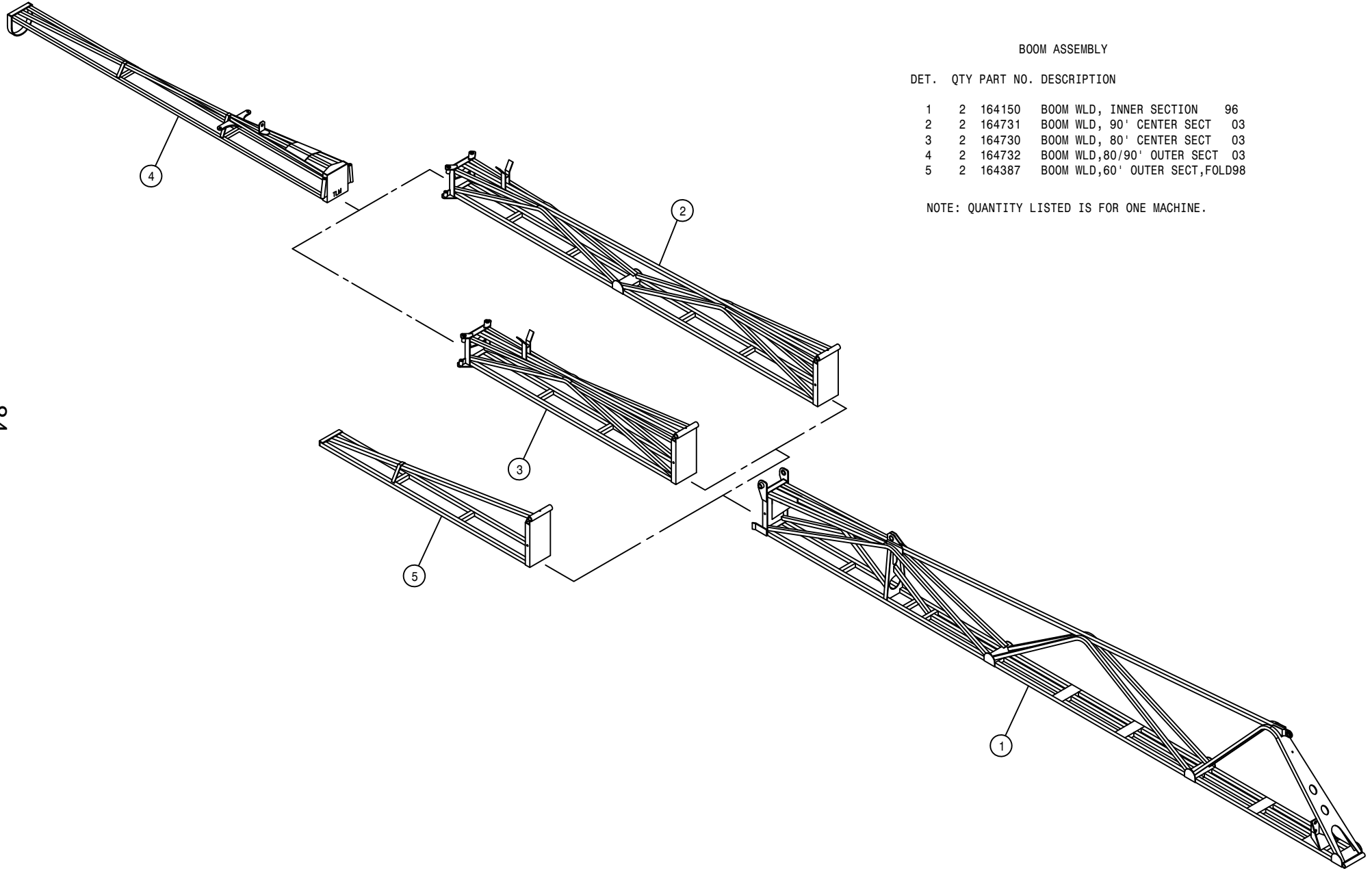

BOOM ASSEMBLY

DET. QTY PART NO. DESCRIPTION

1	2	164150	BOOM WLD, INNER SECTION	96
2	2	164731	BOOM WLD, 90' CENTER SECT	03
3	2	164730	BOOM WLD, 80' CENTER SECT	03
4	2	164732	BOOM WLD, 80/90' OUTER SECT	03
5	2	164387	BOOM WLD, 60' OUTER SECT, FOLD98	

NOTE: QUANTITY LISTED IS FOR ONE MACHINE.

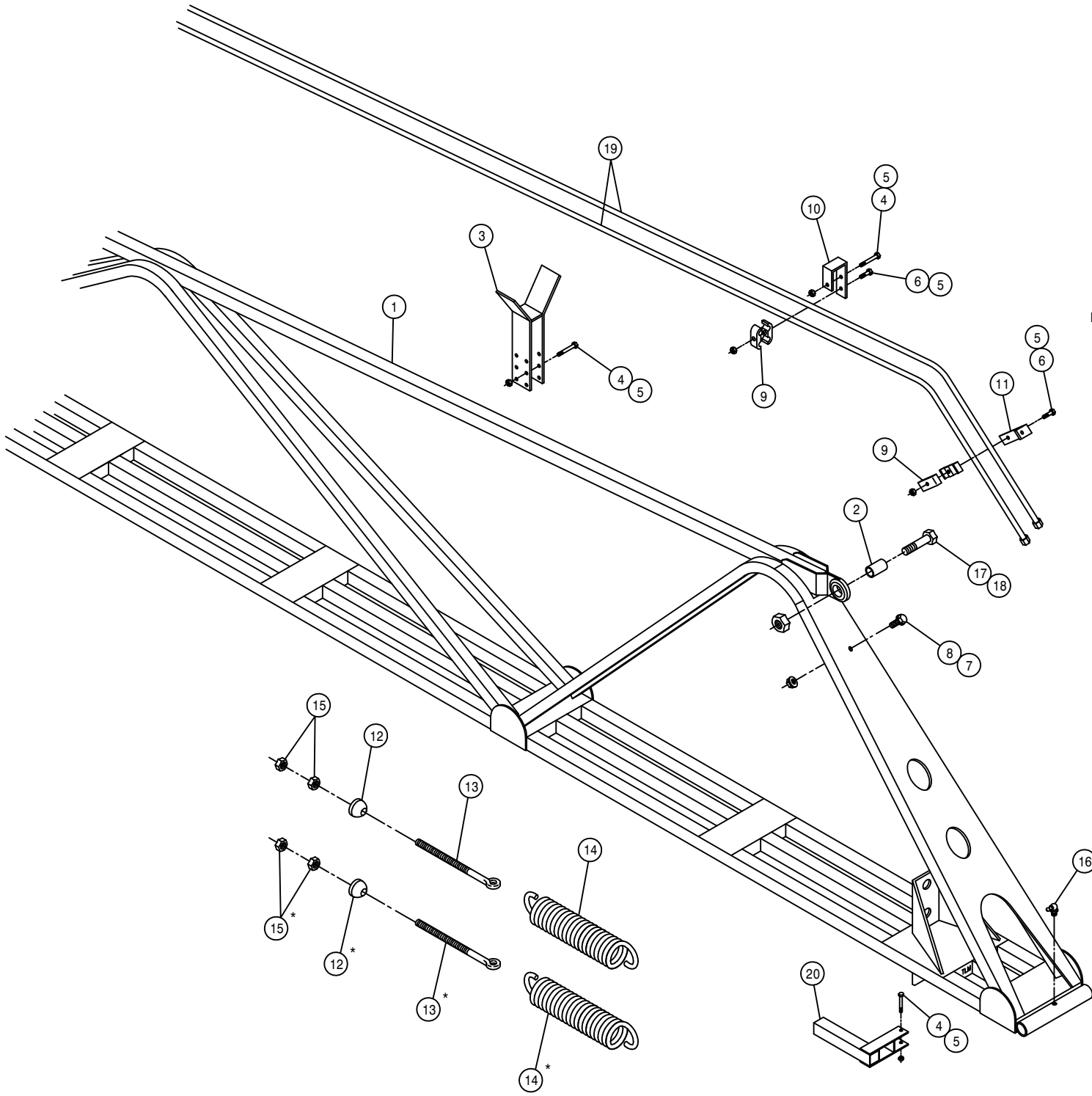

INNER BOOM ASSEMBLY

DET.	QTY	PART NO.	DESCRIPTION	
1	2	164150	BOOM WLD, INNER SECTION	96
2	2	164227	BOOM BALL JOINT BUSH	96
3	2	164266	OUTER BOOM SUPP WLD,80/90'	96
4	18	900007	1/4UNC X 2" HEX BOLT	
5	28	914000	1/4UNC HEX STOVER NUT	
6	10	900004	1/4UNC X 1 1/4 HEX BOLT	
7	2	470121	1/4UNC HEX FLANGE LOCK NUT	
8	2	470118	1/4UNC X 3/4 FLANGE HEX BOLT	
9	10	470287	TUBE CLAMP, .375-.375 (PAIR)	
10	8	164242	HYD TUBE HANGER CLEVIS,BOOM96	
11	2	164243	HYD TUBE HANGER ANGLE,BOOM 96	
12	4	164263	SWIVEL, 5/8 BOOM EYEBOLT	
13	4	164265	5/8UNC X 7 1/2 EYE BOLT	
14	4	482014	SPRING,3.25 X 11.50 EXTENSION	
15	8	910010	5/8UNC HEX NUT	
16	2	471028	GREASE ZERK, 1/4-28 90DEG	
17	2	900844	5/8UNC X 2 3/4 HEX BOLT GR8	
18	2	914010	5/8UNC HEX STOVER NUT	
19	4	615684	HYD TUBE ASSY,BOOM EXT FOLD96	
20	2	164275	NOZL MT WLD	96

NOTE: QUANTITY LISTED IS FOR ONE MACHINE.  
 \*60 FOOT BOOM USES ONE SPRING SETUP.

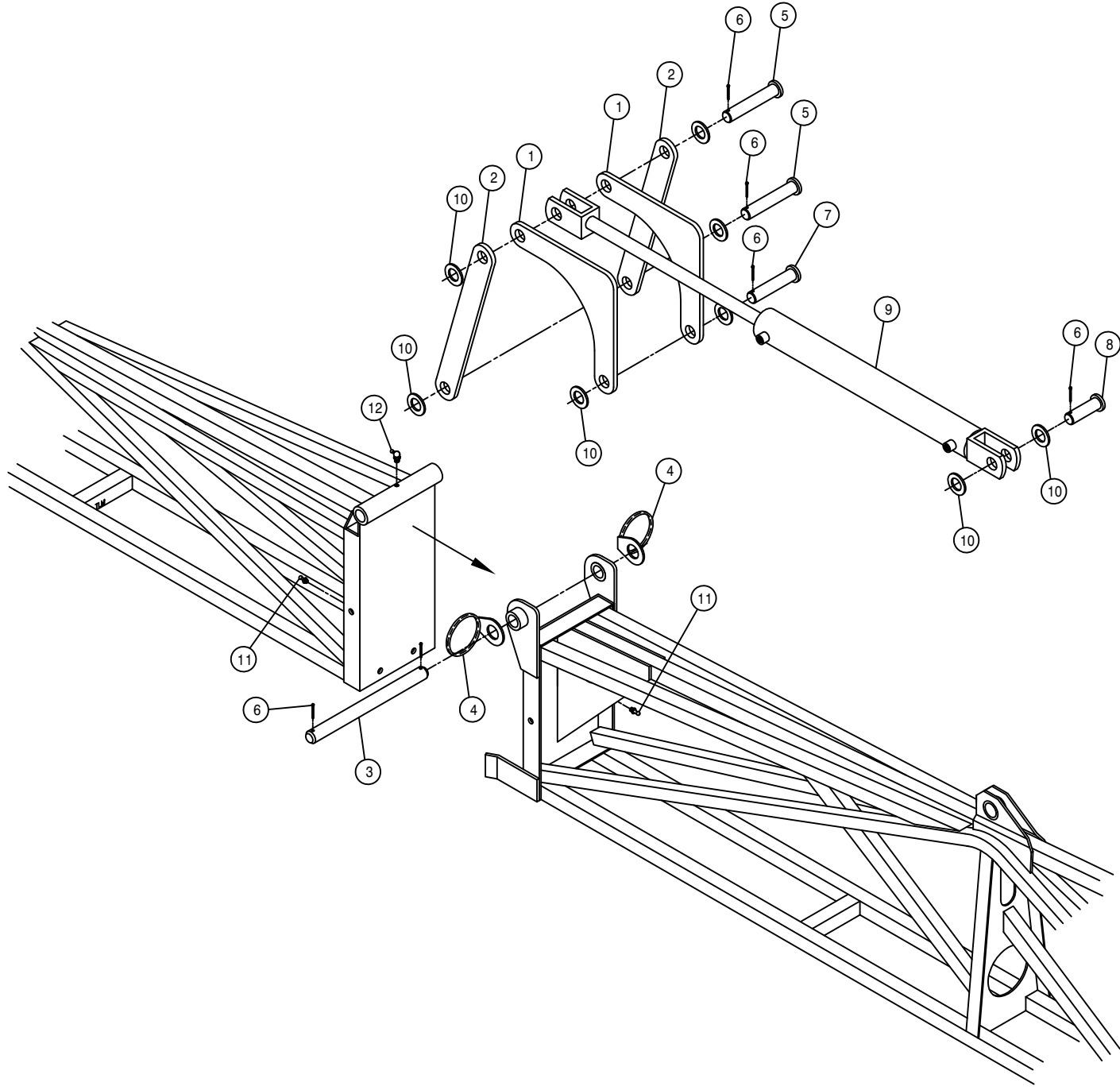

80'-90' BOOM HINGE PIVOT ASSEMBLY

DET.	QTY	PART NO.	DESCRIPTION
	4	164228	FOLDING LINK, INNER BOOM 96
	4	164229	FOLDING LINK, BOOM CNTR SECT96
	2	164231	BOOM PIN, 1.00 X 11.75 96
	4	438302	HOSE SUPPORT RING WLD
	4	470155	CLEVIS PIN, 1.00 X 4.00 PLT
	12	470162	COTTER PIN 3/16 X 1 1/2 SQCUT
	2	472012	CLEVIS PIN, 1.00 X 3.25 PLT
	2	472270	CLEVIS PIN, 1.00 X 2.50 PLT
	2	621213	BOOM CNTR SECT CYL ASSY(12T)04
	16	920008	1" SAE FLAT WASHER
	4	471005	1/4 28 X 1/2 GREASE ZERK
	2	471028	GREASE ZERK, 1/4-28 90DEG

NOTE: QUANTITY LISTED IS FOR ONE MACHINE.

80'-90' OUTER BOOM HINGE ASSEMBLY

DET. QTY PART NO. DESCRIPTION

1	2	160351	BOOM PIVOT PIN, .625 X 11.50
2	2	160979	1/2UNC X 9" EYE BOLT
3	2	160981	SWIVEL, 1/2" BOOM EYEBOLT
4	2	164732	BOOM WLD,80/90' OUTER SECT 03
5	2	164734	CYL MT ARM WLD,80/90 CNTR SECT
6	2	164737	BOOM SPRING PIN WLD 03
7	2	164666	OUTER BOOM SUPPORT WLD 00
8	6	470162	COTTER PIN 3/16 X 1 1/2 SQ CUT
9	2	482013	SPRING,2.50 X 17.00 EXTENSION
10	8	900007	1/4UNC X 2" HEX BOLT
11	4	910008	1/2UNC HEX NUT
12	8	914000	1/4UNC HEX STOVER NUT
13	4	920005	5/8 SAE FLAT WASHER
14	2	471005	1/4 28 X 1/2 GREASE ZERK
15	2	473895	1/4 X 1 3/4 LYNCH PIN
16	2	621554	LADR/SF/BRKWAY CYL,1.50 X12.25
17	2	616042	04C1T-06FJX-06FJX-13 H/A
18	2	618119	9/16MJIC-90-9/16MOR LBO
19	2	618689	9/16MOR-90-9/16MJ .042 CHK VLV
20	6	900266	1/2UNC X 1 3/4 HEX BOLT
21	8	914008	1/2UNC HEX STOVER NUT
22	2	900267	1/2UNC X 2" HEX BOLT
NS	1	621555	REPAIR KIT,HYD CYL 621554

NOTE: 1. QUANTITY LISTED IS FOR ONE MACHINE.  
 2. 621035 - BOOM BREAKAWAY CYLINDER ASSEMBLY.

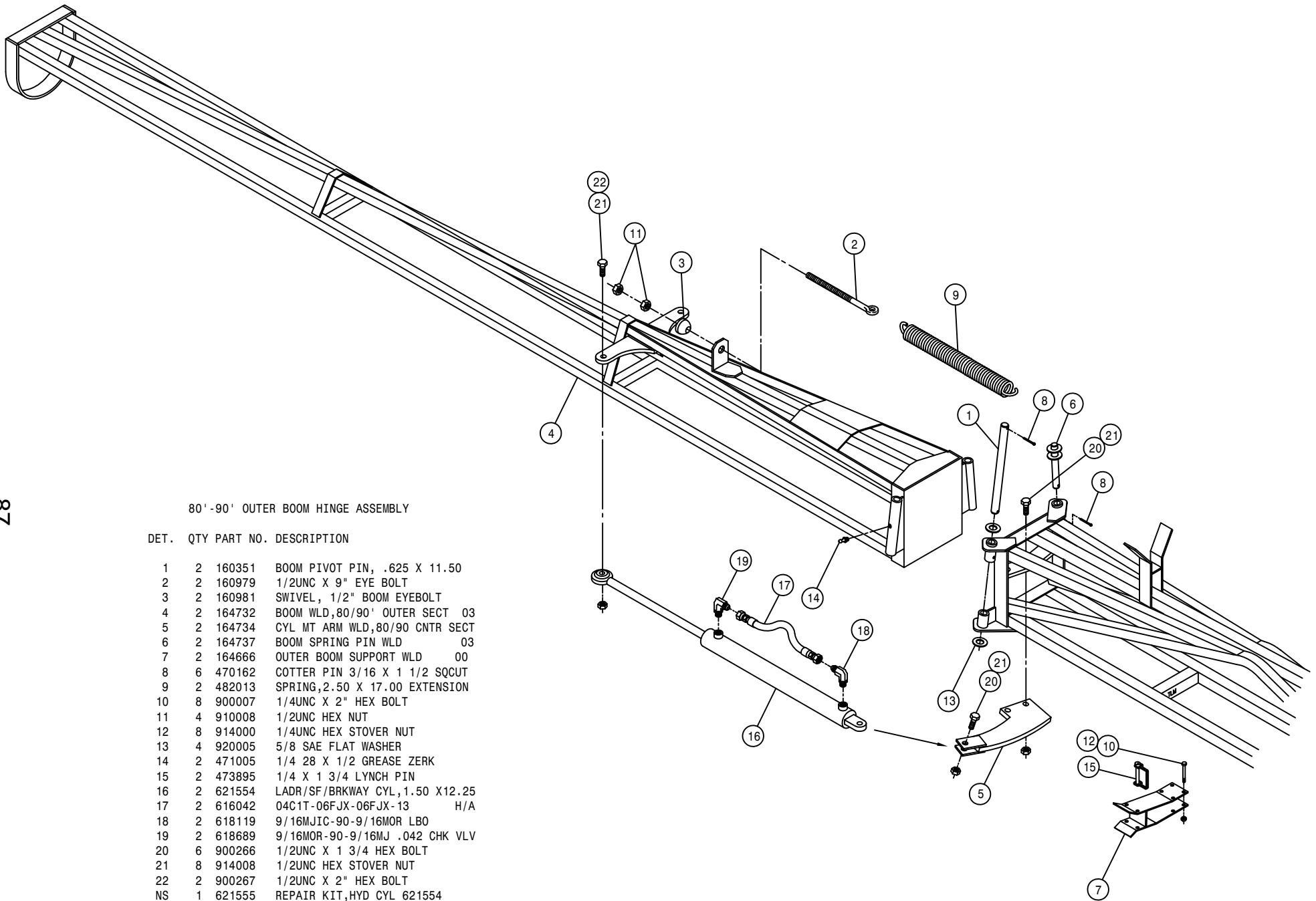

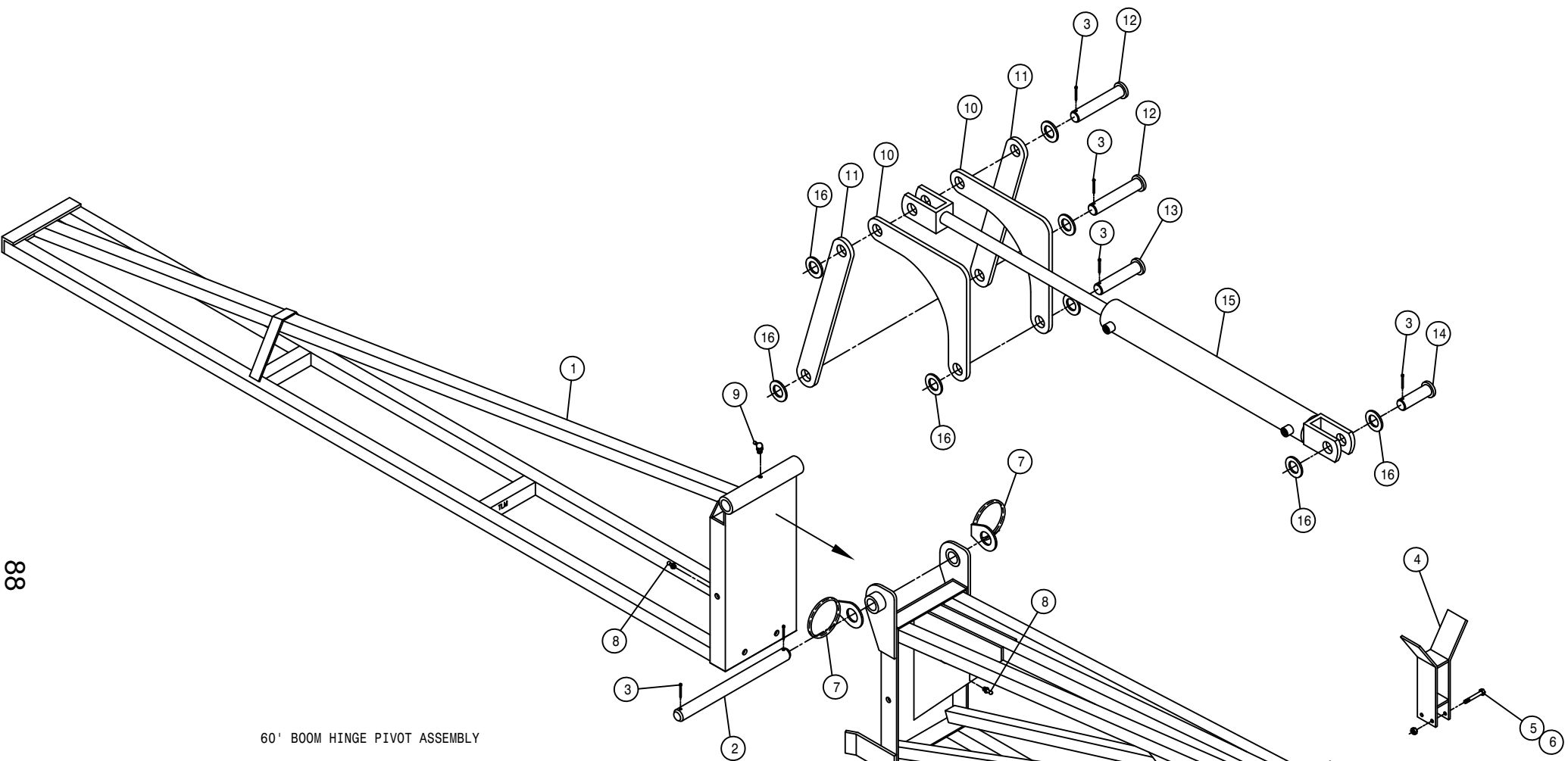

60' BOOM HINGE PIVOT ASSEMBLY

DET.	QTY	PART NO.	DESCRIPTION
1	2	164387	BOOM WLD,60' OUTER SECT,FOLD98
2	2	164231	BOOM PIN, 1.00 X 11.75 96
3	12	470162	COTTER PIN 3/16 X 1 1/2 SQCUT
4	2	164388	OUTER BOOM SUPP WLD,60'FOLD 98
5	4	900007	1/4UNC X 2" HEX BOLT
6	4	914000	1/4UNC HEX STOVER NUT
7	4	438302	HOSE SUPPORT RING WLD
8	4	471005	1/4 28 X 1/2 GREASE ZERK
9	2	471028	GREASE ZERK, 1/4-28 90DEG
10	4	164228	FOLDING LINK, INNER BOOM 96
11	4	164229	FOLDING LINK,BOOM CNTR SECT96
12	4	470155	CLEVIS PIN, 1.00 X 4.00 PLT
13	2	472012	CLEVIS PIN, 1.00 X 3.25 PLT
14	2	472270	CLEVIS PIN, 1.00 X 2.50 PLT
15	2	621213	BOOM CNTR SECT CYL ASSY(12T)04
16	16	920008	1" SAE FLAT WASHER

NOTE: QUANTITY LISTED IS FOR ONE MACHINE.



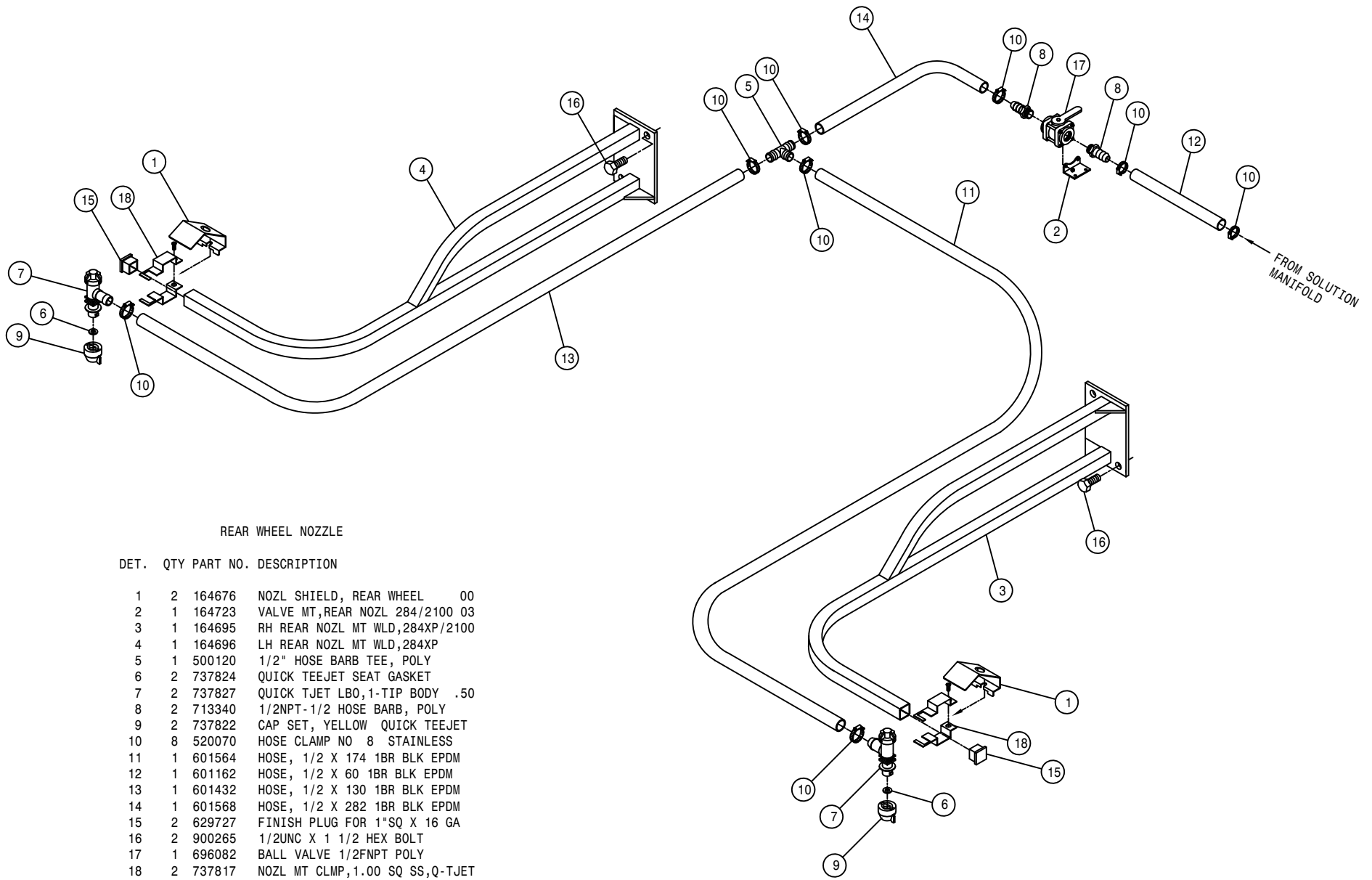

REAR WHEEL NOZZLE

DET. QTY PART NO. DESCRIPTION

1	2	164676	NOZL SHIELD, REAR WHEEL	00
2	1	164723	VALVE MT, REAR NOZL 284/2100	03
3	1	164695	RH REAR NOZL MT WLD, 284XP/2100	
4	1	164696	LH REAR NOZL MT WLD, 284XP	
5	1	500120	1/2" HOSE BARB TEE, POLY	
6	2	737824	QUICK TEEJET SEAT GASKET	
7	2	737827	QUICK TJET LBO, 1-TIP BODY	.50
8	2	713340	1/2NPT-1/2 HOSE BARB, POLY	
9	2	737822	CAP SET, YELLOW QUICK TEEJET	
10	8	520070	HOSE CLAMP NO 8 STAINLESS	
11	1	601564	HOSE, 1/2 X 174 1BR BLK EPDM	
12	1	601162	HOSE, 1/2 X 60 1BR BLK EPDM	
13	1	601432	HOSE, 1/2 X 130 1BR BLK EPDM	
14	1	601568	HOSE, 1/2 X 282 1BR BLK EPDM	
15	2	629727	FINISH PLUG FOR 1" SQ X 16 GA	
16	2	900265	1/2UNC X 1 1/2 HEX BOLT	
17	1	696082	BALL VALVE 1/2FNPT POLY	
18	2	737817	NOZL MT CLMP, 1.00 SQ SS, Q-TJET	

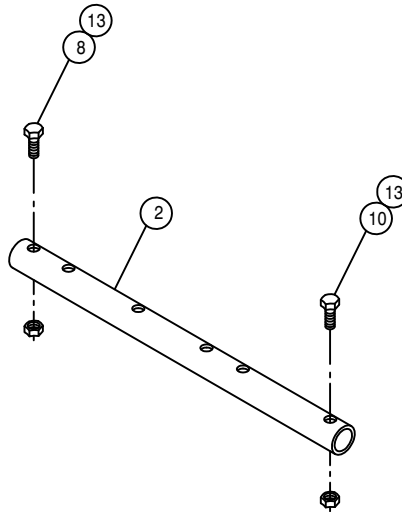
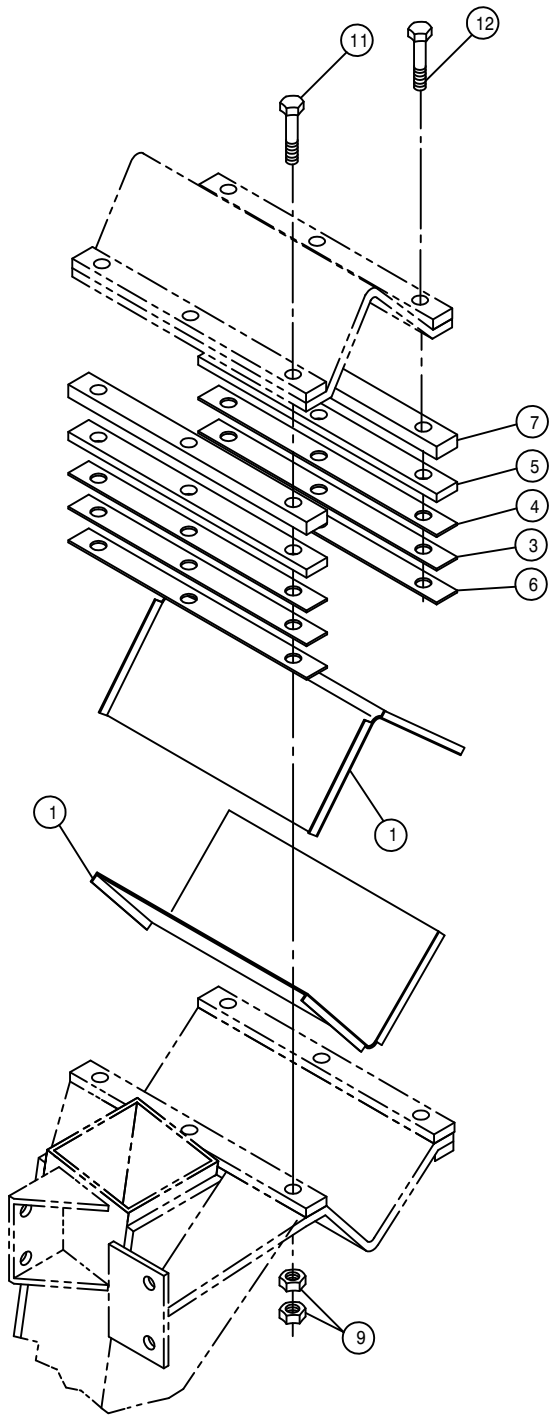

TREAD ADJUSTMENT ASSEMBLY

DET. QTY PART NO. DESCRIPTION

1	8	358703	TREAD ADJ XMBR BEARING ASSY	
2	4	358747	TREAD ADJ CYL EXT TUBE	94
3	8	358767	.025 LEG MT SHIM, 284T	94
4	8	358752	.074 LEG MT SHIM, 284T	94
5	8	358769	.250 LEG MT SHIM, 284T	94
6	8	358768	.037 LEG MT SHIM, 284T	94
7	8	358766	.375 LEG MT SPACER, 284T	94
8	4	900268	1/2UNC X 2 1/2 HEX BOLT	
9	48	914811	5/8UNF HEX NUT GR8	
10	4	900267	1/2UNC X 2" HEX BOLT	
11	12	900837	5/8UNF X 3 1/2 HEX BOLT GR8	
12	12	900838	5/8UNF X 4" HEX BOLT GR8	
13	8	914008	1/2UNC HEX STOVER NUT	

NOTE: QUANTITY LISTED IS FOR ONE MACHINE.

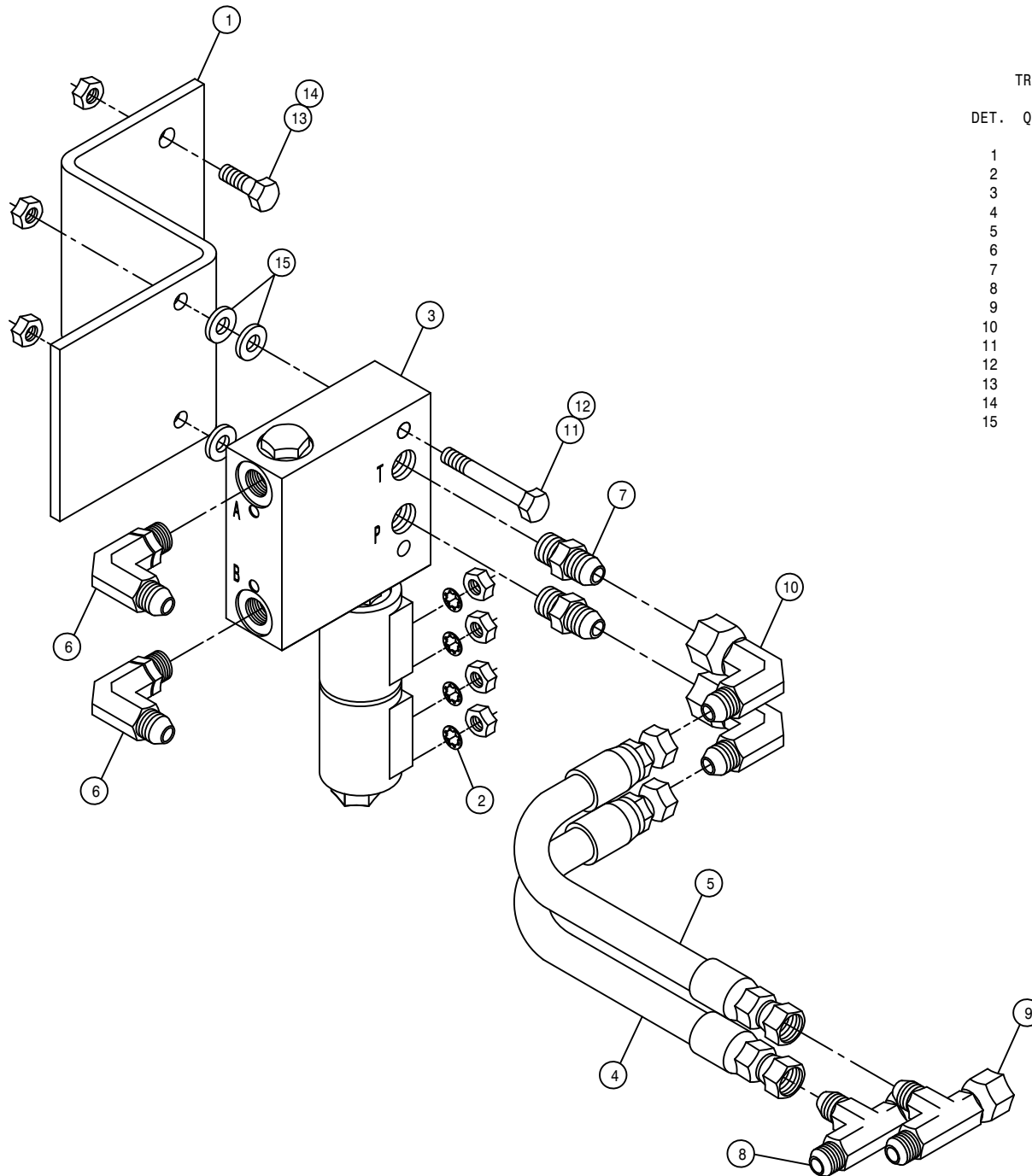

TREAD ADJUST CONTROL VALVE ASSEMBLY

DET. QTY PART NO. DESCRIPTION

1	1	164652	TREAD ADJ VLV MT, 284
2	4	473802	# 8 INT TOOTH STAR WASHER
3	1	606100	TREAD ADJ VLV,284/XP,PWRSYS 03
4	1	615473	06C1T-06FJX-08FJX-18 H/A
5	1	615620	06C1T-06FJX-06FJX-18 H/A
6	2	618119	9/16MJIC-90-9/16MOR LBO
7	2	618126	9/16MJIC-9/16MOR ADPTR
8	1	618451	3/4FJIC SW RUN TEE-3/4MJIC
9	1	618486	9/16FJIC SW RUN TEE-9/16MJIC
10	2	618618	9/16MJIC-90-9/16FJIC SWIV LBO
11	2	900086	5/16UNC X 2 1/4 HEX BOLT
12	2	914002	5/16UNC HEX STOVER NUT
13	2	900129	3/8UNC X 1" HEX BOLT
14	2	914004	3/8UNC HEX STOVER NUT
15	4	920001	5/16 SAE FLAT WASHER

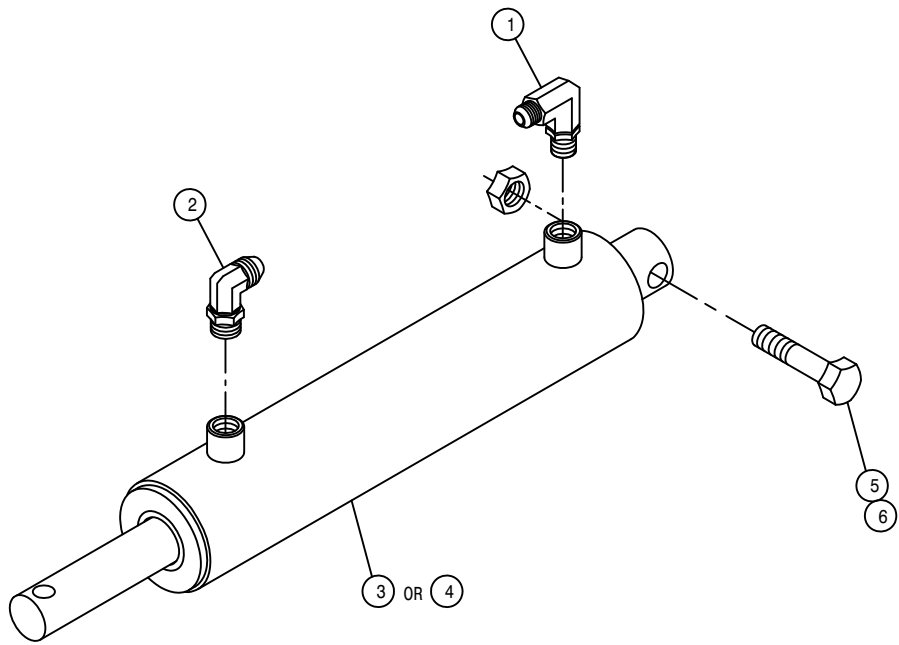

TREAD ADJUSTMENT LEG CYLINDER ASSEMBLY

DET.	QTY	PART NO.	DESCRIPTION	
1	1	614747	.025 ELBOW ASSY,9/16MOR 90D	
2	1	618119	9/16MJIC-90-9/16MOR LBO	
3	1	621530	LH TRD ADJ CYL, DTS8	04
4	1	621532	RH TRD ADJ CYL, DTS8	04
5	1	900268	1/2UNC X 2 1/2 HEX BOLT	
6	1	914008	1/2UNC HEX STOVER NUT	
NS	1	621531	REPAIR KIT, HYD CYL 621530	
NS	1	621533	REPAIR KIT, HYD CYL 621532	

NOTE: 1. 621214 - LH LEG TREAD ADJ CYLINDER ASSEMBLY WITH FITTINGS  
 2. 621215 - RH LEG TREAD ADJ CYLINDER ASSEMBLY WITH FITTINGS

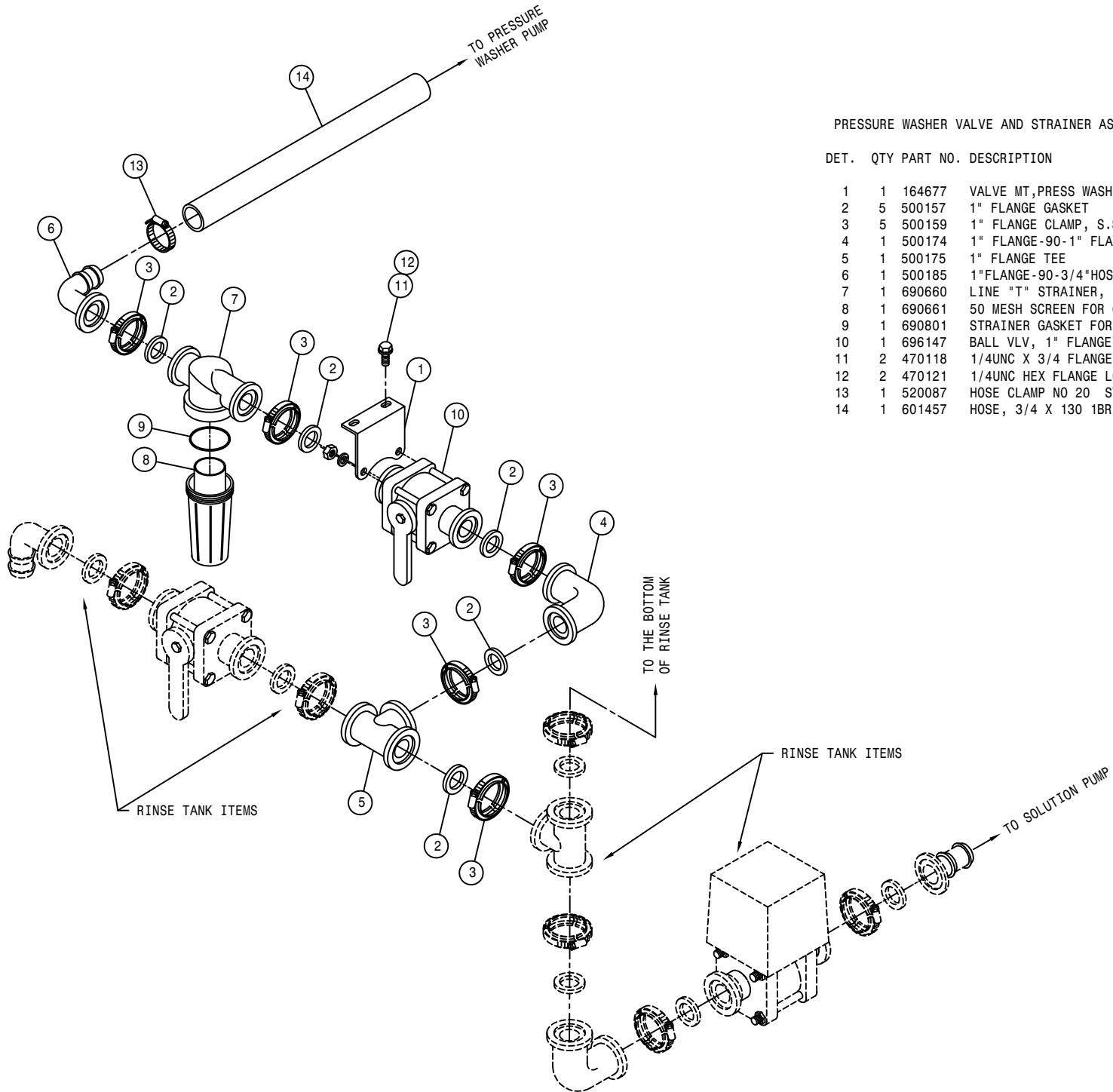

PRESSURE WASHER VALVE AND STRAINER ASSEMBLY

DET.	QTY	PART NO.	DESCRIPTION
1	1	164677	VALVE MT,PRESS WASH 284XP 2001
2	5	500157	1" FLANGE GASKET EPDM
3	5	500159	1" FLANGE CLAMP, S.S.
4	1	500174	1" FLANGE-90-1" FLANGE LBOPOLY
5	1	500175	1" FLANGE TEE POLY
6	1	500185	1"FLANGE-90-3/4"HOSE BARB POLY
7	1	690660	LINE "T" STRAINER, 1" FLANGE
8	1	690661	50 MESH SCREEN FOR 690660
9	1	690801	STRAINER GASKET FOR 690660
10	1	696147	BALL VLV, 1" FLANGE
11	2	470118	1/4UNC X 3/4 FLANGE HEX BOLT
12	2	470121	1/4UNC HEX FLANGE LOCK NUT
13	1	520087	HOSE CLAMP NO 20 STAINLESS
14	1	601457	HOSE, 3/4 X 130 1BR BLK EPDM

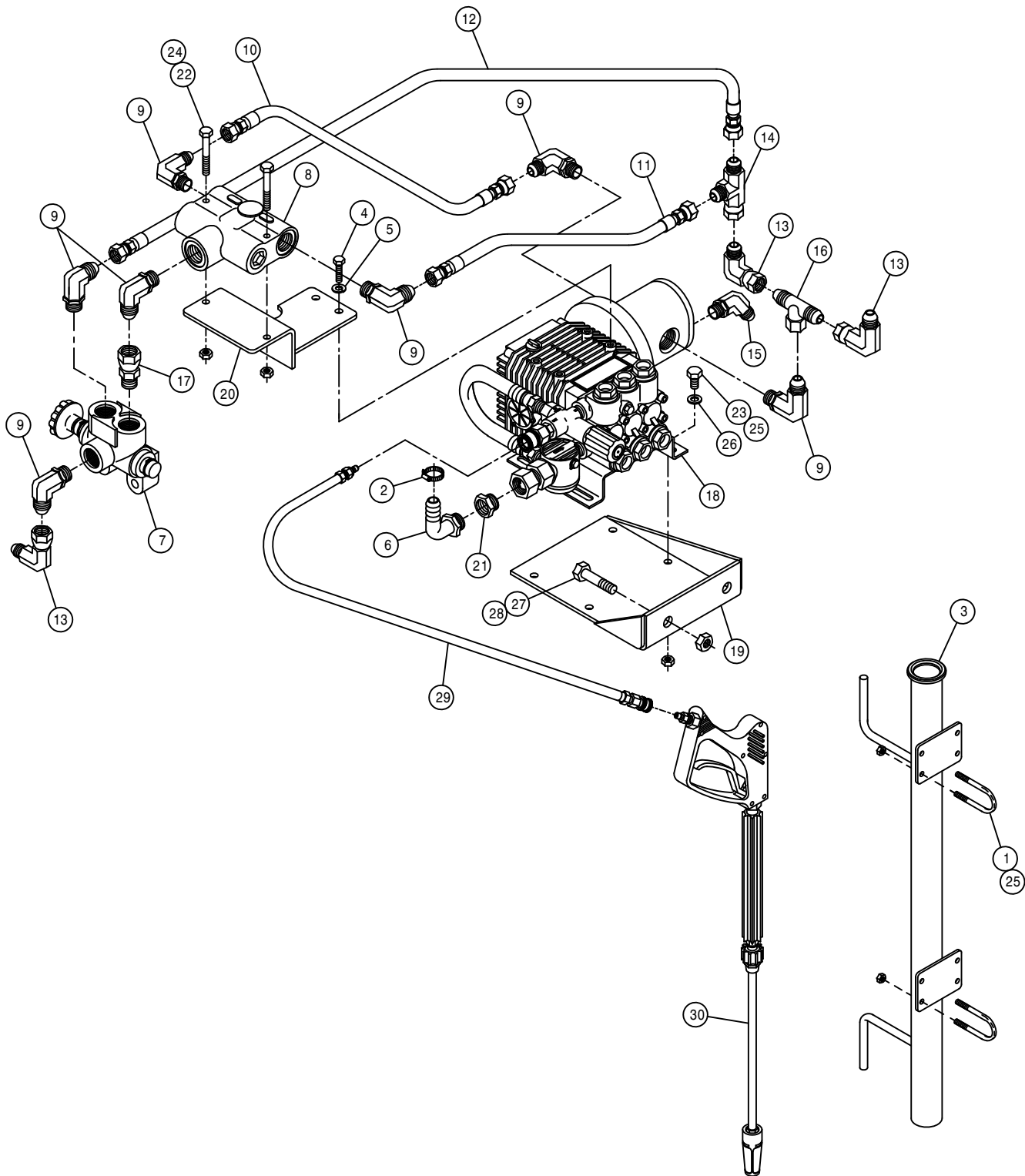

PRESSURE WASHER PUMP ASSEMBLY

DET.	QTY	PART NO.	DESCRIPTION
	1	4 473911	5/16UNC-1.31ID-2.00 U-BOLT
	2	1 520087	HOSE CLAMP NO 20 STAINLESS
	3	1 690732	PRESSURE WASHER WAND MT WLD
	4	4 473803	8MM-1.25 X 16MM HEX BOLT
	5	4 473804	8MM LOCK WASHER
	6	1 500054	3/4NPT-90-3/4 HOSE BARB, POLY
	7	1 606005	GRESEN SELECTOR VALVE S-10
	8	1 607518	FLO DIV BGR56 6GPM PRI 7/8FOR
	9	7 611128	7/8MJIC-90-7/8MOR LBO
	10	1 616143	10C1T-10FJX-10FJX-13 H/A
	11	1 616144	10C1T-10FJX-10FJX-14 H/A
	12	1 616145	10C1T-10FJX-10FJX-26 H/A
	13	3 618301	7/8MJIC-90-7/8FJIC SWIV LBO
	14	1 618333	7/8FJIC SW RUN TEE-7/8MJIC
	15	1 618425	9/16MJIC-45-9/16MOR LBO
	16	1 618593	7/8FJ SW BRANCH TEE-7/8MJ
	17	1 618594	7/8FJIC SWIV-7/8MOR ADPTR
	18	1 690672	PRESSURE WASHER,PAGE 320 HYD
	19	1 690784	PRESS WASH PUMP MT WLD 284XP
	20	1 690788	PRESS WASH FLOW DIV MT 284XP
	21	1 715449	3/4FNPT X 3/4MGT ADPTR BRS
	22	2 900023	1/4UNC X 2 1/4 HEX BOLT
	23	4 900064	5/16UNC X 3/4 HEX BOLT
	24	2 914000	1/4UNC HEX STOVER NUT
	25	12 914002	5/16UNC HEX STOVER NUT
	26	4 920001	5/16 SAE FLAT WASHER
	27	2 900269	1/2UNC X 2 3/4 HEX BOLT
	28	2 914008	1/2UNC HEX STOVER NUT
	29	1 690791	HOSE, PRESSURE WASHER 690672
	30	1 690673	TRIGGER GUN ASSY FOR 690672

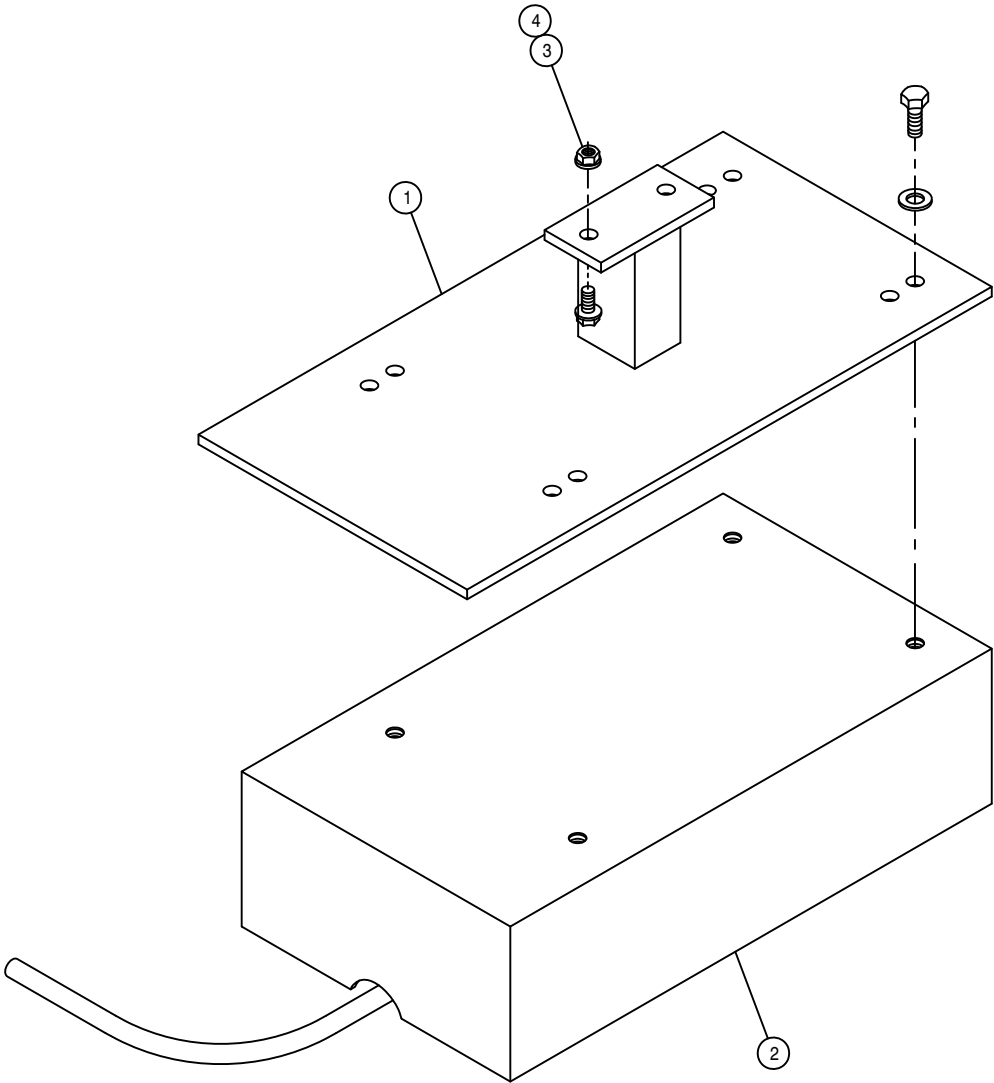

RADAR OPTION

DET.	QTY	PART NO.	DESCRIPTION
1	1	690462	RADAR MTG BRKT WLD, INJ SYS
2	1	690599	RAVEN RADAR UNIT W/CABLE
3	2	470118	1/4UNC X 3/4 FLANGE HEX BOLT
4	2	470121	1/4UNC HEX FLANGE LOCK NUT

# NOTICE

---

The following page contains decals for the model 284 XP.

These decals can be obtained from Hagie Mfg. Co. and should be used whenever your machine is repainted or when the decals become worn, weathered, or faded.

Special attention should be paid to decals involving personal safety. They have been attached for your protection.

**KEEP THEM IN PLACE.**

Contact: Hagie Manufacturing Co.  
Box 273  
Clarion, Iowa 50525



## 284XP DECALS

QTY.	PART NO.	DESCRIPTION	LOCATION
1	650831	EMERGENCY STOP DECAL	ON LOWER LH FRONT CAB FOAM
1	650320	EMERGENCY EXIT DECAL	ON LOWER REAR OF EXIT WINDOW
1	650355	CONSOLE COVER PANEL DECAL	ON CONSOLE SHEET METAL
1	650340	PARK BRAKE DECAL	NEAR PARK SWITCH
1	650822	SOLUTION PUMP DECAL	ON FRONT CROSSMEMBER
1	650847	NO PASSENGER DECAL	REAR CORNER OF CAB
2	650848	SLIP OR FALL DECAL	2-ON EACH FUEL TANK
2	650849	ENGINE FUEL DECAL	NEAR EACH FUEL TANK NECK
2	650850	CHEMICAL DECAL	ON SOLUTION TANK LIDS
2	650851	SHIELDS DECAL	ON SIDE OF TOP ENGINE COVER
1	650852	READ MANUAL DECAL	ON LOWER LH FRONT CAB FOAM
1	650326	HAGIE DECAL	ON FRONT MAINFRAME SHIELD
2	650954	DIESEL DECAL	NEAR EACH FUEL NECK
1	650981	COOLING SYSTEM DECAL	NEAR RADIATOR CAP
1	650982	ELECTRICAL DECAL	RIGHT HAND SIDE OF OIL TANK
4	650985	WHEEL BOLT TORQUE DECAL	ON EACH WHEEL RIM
1	650323	DECAL SET, HAGIE 284 STRIPE	ON EACH ENGINE HOOD
2	650324	DECAL STRIPE, 3 X 72	ON EACH TANK SHIELD
1	650329	SPRAY CONTROL/TRAC DECAL	ON INSTRUMENT PANEL
1	650336	FOLD BOOM WARNING DECAL	ON LOWER REAR OF EXIT WINDOW
1	650337	ELECTROCUTION HAZARD DECAL	ON LOWER REAR OF EXIT WINDOW
1	650339	HYDRAULIC OIL INJ. DECAL	ON LOWER REAR OF EXIT WINDOW
1	650347	NOTICE-R134A CHARGE DECAL	NEXT TO A/C COMPRESSOR
1	650348	NOTICE-DRAIN AIR TANK DECAL	ON AIR TANK
2	650358	XP DECAL	ON EACH ENGINE HOOD
1	650367	AIR FILTER INSTRUCTION DECAL	ON ENGINE AIR FILTER END CAP

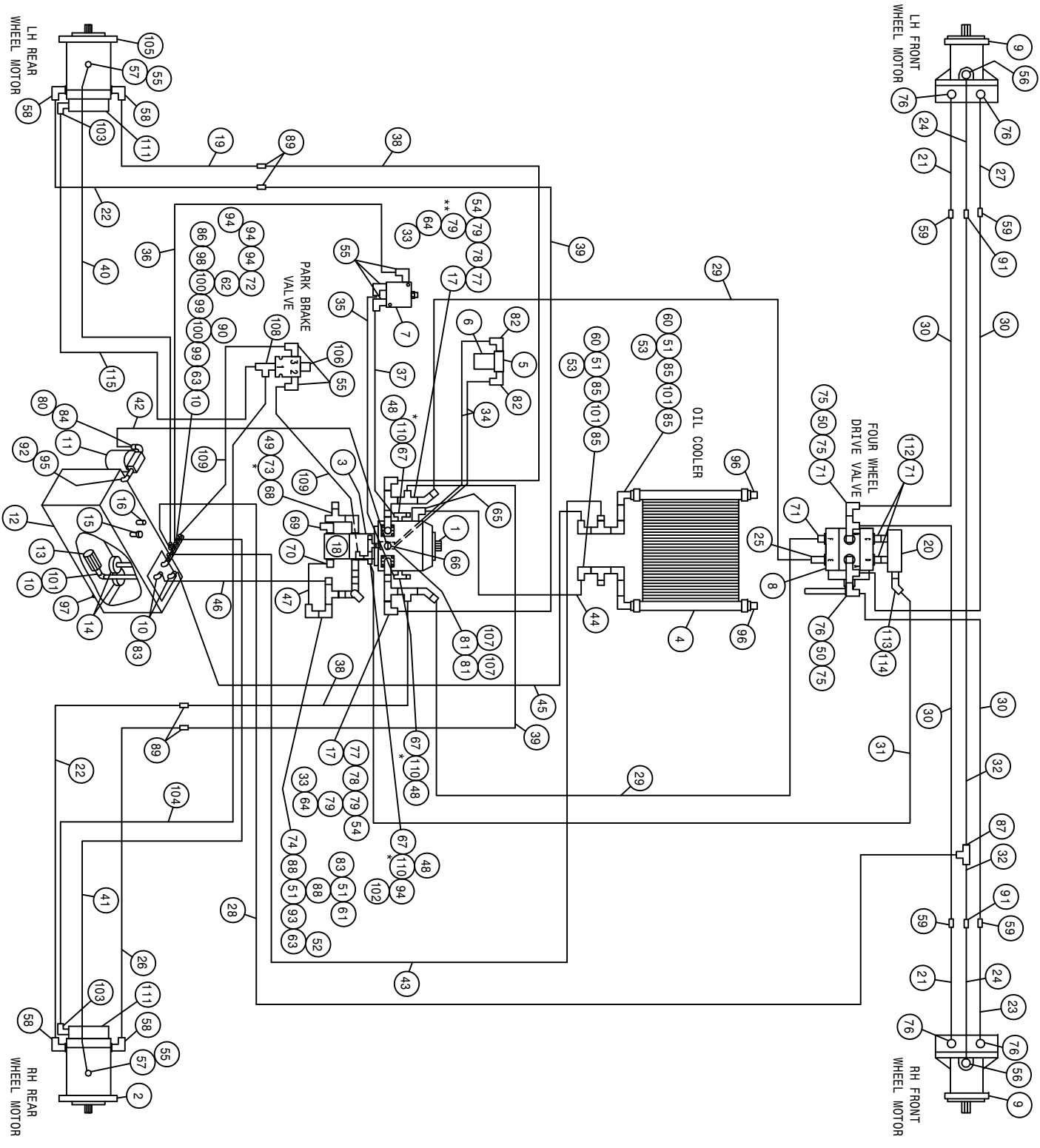

\*NOTE:  
 REFER TO DETAIL 73 TO CHECK AUX. SYSTEM - 1850 PSI  
 REFER TO DETAIL 110 TO CHECK LIMIT SETTING - 4500 PSI  
 REFER TO DETAIL 110 TO CHECK CHARGE PRESSURE - 380 PSI  
 \*\*DETAIL 79 IS USED WITHOUT TRACTION VALVE

284XP HYDRAULIC SCHEMATIC 2004  
REFERENCE DRAWING NO. 498808S1

DET.	QTY	PART NO.	DESCRIPTION	DET.	QTY	PART NO.	DESCRIPTION
1	1	606954	SUND 130CC PUMP,B-MT	98	59		
2	1	610557	SUND M35-3102 WHL MTR W/SHFT	60	2	618138	1 1/16MJIC UNION
3	1	606932	SUND GEAR PUMP,1.60CI,SPLINED	61	1	716000	1IN HOSE BARB-90-1MNPT
4	1	618606	OIL COOLER, BLISSFIELD 65027	62	1	504001	3/4 HOSE BARB-90-1MNPT
5	1	605608	HYD FILTER HEAD, DONALDSON	63	2	505213	RED BUSH 3/4 X 1/4 BLK MAL
6	1	605609	HYD FILTER ELEMENT, DONALDSON	64	2	618630	RED BUSH 1 X 3/4 BLK MAL
7	1	610580	REMOTE FLUSHING VALVE, SUND	65	1	618564	1 5/16MJ-45-1 5/16FJ SWIV LBO
8	1	606003	GRESEN SELECTOR VALVE DS-12	66	1	618626	1IN HOSE BARB-90-1 5/16MOR
9	2	610571	SUND M35-3002 WHL MTR	67	1	618126	1 1/4 HOSE BARB-45-1 5/8MOR
10	4	505300	BLK PIPE EL 90DEG 1.00NPT	68	3	618535	9/16MJIC-9/16MOR ADPTR
11	1	605601	PARKER FILTER ASSY,10M,1.25NPT	69	1	611128	7/8MJIC-90-1 1/16MOR LBO
12	1	760264	HYD TANK WLD,204/254/284 2002	70	1	618075	3/4 HOSE BARB-1 1/16MOR
13	1	605600	TANK FILTER, 100 MESH,1"FNPT	71	4	611127	1 1/16MJIC-1 1/16MOR ADPTR
14	2	605603	LINE SUMP DIFUSER	72	1	618520	1/4MNPT RUN TEE-9/16MJIC
15	1	611052	FILLER BREATHER 3/4NPT	73	1	618333	7/8FJIC SW RUN TEE-7/8MJIC
16	1	614453	DIPSTICK, 8IN	74	1	618090	1 5/16MOR-1FNPT ADPTR
17	2	618461	1 1/4 SPLIT FLANGE KIT	75	3	618191	1 1/16MJ-90-1 1/16FJ SWIV LBO
18	1	606929	SUND GEAR PUMP .66CI, SPLINED	76	5	618248	1 1/16MJIC-90-1 1/16MOR LBO
19	1	615798	LH REAR LEG HYD TUBE ASSY XP	77	2	618459	1 1/4FLANGE-90-1 5/8MJIC
20	1	606020	4WD SELECTOR VALVE MANIF 2002	78	2	618547	1 5/8FJIC-1 5/16MJIC ADPTR
21	2	615792	FRT LEG INNER HYD TUBE ASSY XP	79	4	618619	1 5/16FJ SW RUN TEE-1 5/16MJ
22	2	615796	REAR LEG HYD TUBE ASSY XP	80	1	506410	BLK PIPE ST EL 90DEG 1.25NPT
23	1	615794	RH FRT LEG OUTR HYD TUBE ASSY	81	2	618327	3/4MJIC-7/8MOR ADPTR
24	2	615793	FRT LEG CNTR HYD TUBE ASSY XP	82	2	618474	3/4MJIC-90-1 1/16MOR LBO
25	1	607527	FLOW CTRL VALVE,32GPM IN-LINE	83	3	714560	1NPT X 1 HOSE BARB
26	1	615797	RH REAR LEG HYD TUBE ASSY XP	84	1	715660	HOSE BARB 1 1/4NPT X 1 1/4
27	1	615795	LH FRT LEG OUTR HYD TUBE ASSY	85	4	505200	BLK PIPE ST EL 90DEG 1.00NPT
28	1	614704	06C1T-06FJX-06FJX-156	86	1	618018	9/16MJIC-1/2MNPT ADPTR
29	2	614724	12TNM-12FJX-12FJX-106	87	1	618019	9/16MJIC UNION TEE
30	4	616141	12C2AT-12FJX-12FJX-112	88	2	505105	1MNPT HEX PIPE NIPPLE STL
31	1	614101	04C1T-06FJX-06FJX-133	89	4	618577	1 5/16MJIC UNION
32	2	616140	06C1T-06FJX-08FJX-97	90	1	713220	HOSE BARB 3/4 NPT X 3/4
33	2	618541	1 5/16FJIC-1 1/16MJIC ADPTR	91	2	618314	3/4MJIC UNION
34	2	615465	08C1T-08FJX-08FJX-33	92	1	506602	PIPE NIPPLE 1 1/4NPT-2 1/2
35	1	616252	04C2AT-06FJX-06FJX-13	93	1	505200	BLK PIPE ST EL 90DEG 1.00NPT
36	1	616048	04C1T-06FJX-06FJX-35	94	4	618486	9/16FJIC SW RUN TEE-9/16MJIC
37	1	616253	04C2AT-06FJX-06FJX-23	95	1	506303	BLK PIPE EL 90DEG 1.25NPT
38	2	614735	12TNM-16FJX-16FJX-75	96	2	505102	PIPE PLUG 1.00NPT SQ HD
39	2	616142	12TNM-16FJX-16FJX-93	97	1	470308	1/2MNPT DRAIN PLUG,AL HD,MAG
40	1	614345	06C1T-06FJX-06FJX-120	98	1	504210	RED BUSH 3/4 NPT X 1/2 NPT
41	1	615449	06C1T-06FJX-06FJX-126	99	2	504702	CLOSE NIPPLE .75NPT
42	1	601549	HOSE, 1 1/4 X 23 1FBR-1SPI	100	2	504955	BLK PIPE TEE .75NPT
43	1	601401	HOSE, 3/4 X 88 1FBR-1SPI	101	3	505203	BLK PIPE NIPPLE 1.00NPT-4.00
44	1	601403	HOSE, 1 X 72 1FBR-1SPI	102	1	618618	9/16MJIC-90-9/16FJIC SWIV LBO
45	1	601404	HOSE, 1 X 87 1FBR-1SPI	103	2	618114	9/16MJIC-90-7/16MOR LBO
46	1	601382	HOSE, 1 X 50 1FBR-1SPI	104	1	614639	04C1T-06FJX-06FJX-126
47	1	601399	HOSE, 3/4 X 13 1FBR-1SPI	105	1	610621	SUND M35-3102 WHL MTR
48	3	618531	9/16FJIC CAP NUT	106	1	610318	HYD SOLE VLV,2P-3W,9/16FOR,12V
49	1	618328	7/8FJIC CAP NUT	107	2	618609	3/4MJIC-90-3/4FJIC SWIV LBO
50	2	618487	1 1/16FJ SW RUN TEE-1 1/16MJ	108	1	618444	9/16MOR RUN TEE-9/16MJIC
51	4	505101	BLK PIPE TEE 1.00NPT	109	2	616056	04C1T-06FJX-06FJX-32
52	1	610300	3/4MJIC-3/4MNPT ADPTR	110	3	618514	9/16FJ SW BRANCH TEE-9/16MJ
53	2	714331	1 NPT X 3/4 HOSE BARB	111	2	828092	MICO HYD BRAKE
54	2	618640	1 5/16MJ-90-1 5/16FJ SWIV LBO	112	2	618578	1 1/16FJIC SWIV-1 1/16MOR
55	7	618119	9/16MJIC-90-9/16MOR LBO	113	1	618005	1 1/16MOR-9/16FOR ADPTR
56	2	618183	3/4MJIC-90-7/8MOR LBO	114	1	618425	9/16MJIC-45-9/16MOR LBO
57	2	618172	7/8MOR-9/16FOR ADPTR	115	1	614152	04C1T-06FJX-06FJX-114
58	4	618576	1 5/16MJIC-90-1 1/16MOR LBO				H/A

BOOM CONTROL VALVE

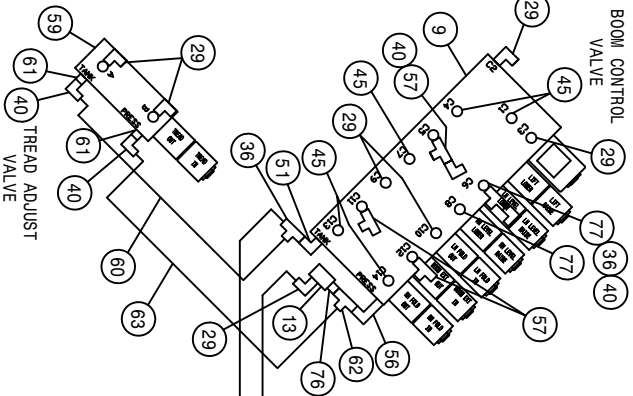

NOTE: REFER TO DETAIL 7 RELIEF PRESSURE SETTING.  
\*\*BOOM RELIEF SETTING - 2650 PSI

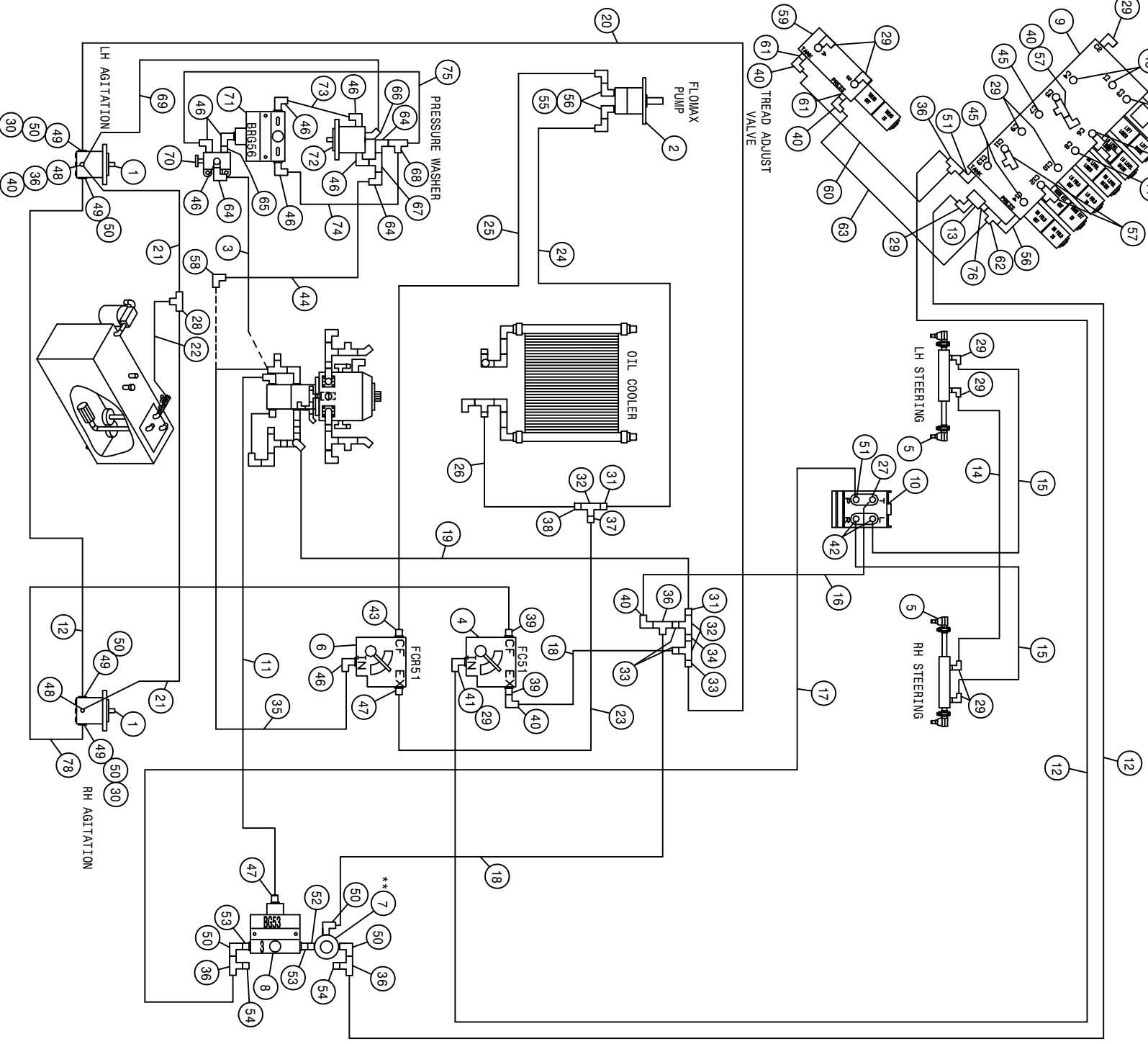

284XP HYDRAULIC SCHEMATIC 2004  
REFERENCE DRAWING NO. 498808S2

DET.	QTY	PART NO.	DESCRIPTION	DET.	QTY	PART NO.	DESCRIPTION
1	2	610510	CESSNA GEAR MOTOR 1.48CI	40	7	618618	9/16MJIC-90-9/16FJIC SWIV LBO
2	1	690573	HYD MOTOR, FLOMAX HI-SPEED	41	1	618172	7/8MOR-9/16FOR ADPTR
3	1	616147	10C1T-10FJX-10FJX-89	42	2	618109	9/16MJIC-3/4MOR ADPTR
4	1	606827	FLO CONT FC51 0-3 VARI 7/8FOR	43	1	618327	3/4MJIC-7/8MOR ADPTR
5	2	621516	STRG CYL ASSY, 2100	44	1	616146	10C1T-10FJX-10FJX-68
6	1	606818	FLO CONT FCR51 0-16GPM 7/8FOR	45	5	618126	9/16MJIC-9/16MOR ADPTR
7	1	607512	RELIEF VALVE, RL50, 1850 PSI	46	8	611128	7/8MJIC-90-7/8MOR LBO
8	1	610307	FLO DIV BGS53 3GPM PRI 7/8FOR	47	2	611126	7/8MJIC-7/8MOR ADPTR
9	1	606102	BOOM VLV, X11/284/2100 PWRSYS03	48	2	618338	9/16MJIC-45-1/4MNPT LBO
10	1	749318	STRG MTR, 7.3CID, NON-LOAD 1031	49	4	618092	1 1/16MOR-1/2FNPT ADPTR
11	1	614664	10C1T-10FJX-10FJX-98	50	7	618107	9/16MJIC-90-1/2MNPT LBO
12	3	614693	06C1T-06FJX-06FJX-168	51	2	618115	9/16MJIC-90-3/4MOR LBO
13	1	605615	HYD FILTER, INLINE 25M 9/16FOR	52	1	500000	1/2MNPT HEX PIPE NIPPLE STL
14	1	611246	04C1T-06FJX-06FJX-174	53	2	618072	7/8MOR-1/2FNPT ADPTR
15	2	614464	04C1T-06FJX-06FJX-96	54	2	618531	9/16FJIC CAP NUT
16	1	616172	04C1T-06FJX-06FJX-60	55	2	618609	3/4MJIC-90-3/4FJIC SWIV LBO
17	1	616026	04C1T-06FJX-06FJX-37	56	3	618241	3/4MJIC-90-3/4MOR LBO
18	2	616026	04C1T-06FJX-06FJX-37	57	3	618444	9/16MOR RUN TEE-9/16MJIC
19	1	616057	08C1T-08FJX-08FJX-88	58	1	618466	7/8MJIC-90-7/8MJIC LBO
20	1	614571	06C1T-06FJX-06FJX-126	59	1	606100	TREAD ADJ VLV, 284/XP, PWRSYS 03
21	2	611204	04C1T-06FJX-06FJX-78	60	1	615620	06C1T-06FJX-06FJX-18
22	1	615452	06C1T-06FJX-06FJX-16	61	2	618126	9/16MJIC-9/16MOR ADPTR
23	1	615521	10C1T-10FJX-10FJX-18	62	1	618451	3/4FJIC SW RUN TEE-3/4MJIC
24	1	615465	08C1T-08FJX-08FJX-33	63	3	615473	06C1T-06FJX-08FJX-18
25	1	614662	08C1T-08FJX-08FJX-72	64	3	618301	7/8MJIC-90-7/8FJIC SWIV LBO
26	1	601384	HOSE, 3/4 X 40 JFBR-1SP1	65	1	618594	7/8FJIC SWIV-7/8MOR ADPTR
27	1	618709	9/16MJIC-90-3/4MOR EX LG LBO	66	1	618425	9/16MJIC-45-9/16MOR LBO
28	1	618019	9/16MJIC UNION TEE	67	1	618593	7/8FJ SW BRANCH TEE-7/8MJ
29	12	618119	9/16MJIC-90-9/16MOR LBO	68	1	618333	7/8FJIC SW RUN TEE-7/8MJIC
30	2	618634	9/16MJIC-45-9/16FJIC SWIV LBO	69	1	614627	06C1T-06FJX-06FJX-45
31	2	611147	3/4MJIC-1/2MNPT ADPTR	70	1	606005	GRESN SELECTOR VALVE S-10
32	3	503820	BLK PIPE TEE .50NPT	71	1	607518	FLO DIV BGR56 6GPM PRI 7/8FOR
33	3	618018	9/16MJIC-1/2MNPT ADPTR	72	1	690672	PRESSURE WASHER, PACE 320 HYD
34	1	503600	CLOSE NIPPLE .50NPT	73	1	616143	10C1T-10FJX-10FJX-13
35	1	616161	10C1T-10FJX-10FJX-101	74	1	616144	10C1T-10FJX-10FJX-14
36	6	618486	9/16FJIC SW RUN TEE-9/16MJIC	75	1	616145	10C1T-10FJX-10FJX-26
37	1	618325	7/8MJIC-1/2MNPT ADPTR	76	1	618692	3/4FJIC SWIV-9/16MOR ADPTR
38	1	712440	1/2 NPT X 3/4 HOSE BARB	77	2	614763	9/16MJIC-9/16MOR, .042 CHK ADPT
39	2	618310	9/16MJIC-7/8MOR ADPTR	78	1	614704	06C1T-06FJX-06FJX-156

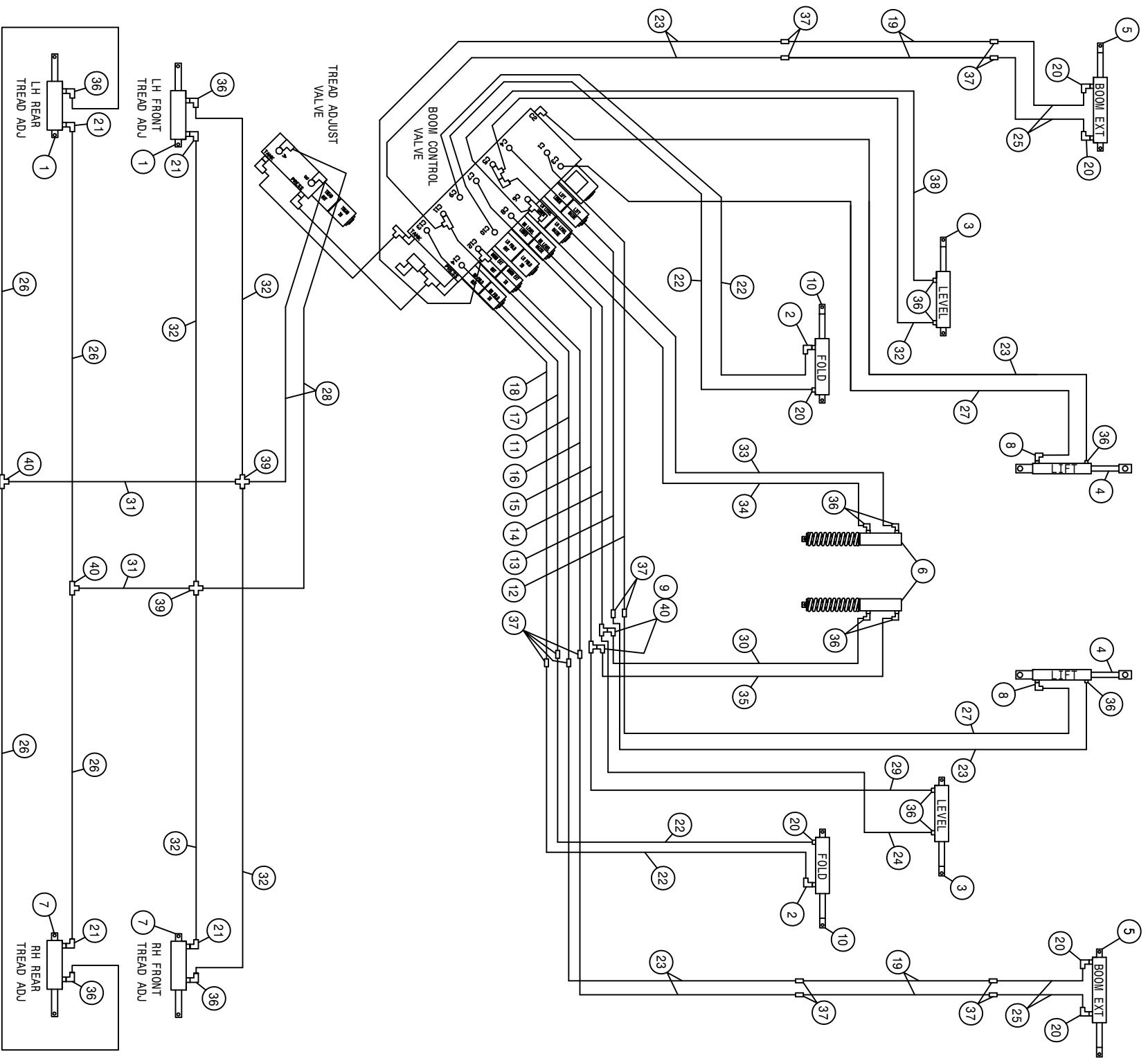

284XP HYDRAULIC SCHEMATIC 2004  
REFERENCE DRAWING NO. 498808S3

DET.	QTY	PART NO.	DESCRIPTION	DET.	QTY	PART NO.	DESCRIPTION
1	2	621530	LH TRD ADJ CYL, DTS8	21	4	614747	.025 ELBOW ASSY, 9/16MOR 90D
2	2	618688	9/16MOR-90-9/16MJ .025 CHK VLV	22	4	615442	04C1T-06FJX-06FJX-55
3	2	621522	BOOM LEVEL CYL ASSY	23	6	616040	04C1T-06FJX-06FJX-67
4	2	621518	TRANSOM LIFT CYL ASSY	24	1	616028	04C1T-06FJX-06FJX-47
5	2	621526	BOOM CNTR SECT CYL ASSY(12T)	25	4	616043	04C1T-06FJX-06FJX-23
6	2	621524	ACCUMULATOR CYL ASSY	26	4	614715	04C1T-06FJX-06FJX-43
7	2	621532	RH TRD ADJ CYL, DTS8	27	2	616174	04C1T-06FJX-06FJX-70
8	2	618689	9/16MOR-90-9/16MJ .042 CHK VLV	28	2	611210	04C1T-06FJX-06FJX-156
9	2	618618	9/16MJIC-90-9/16FJIC SWIV LBO	29	1	614714	04C1T-06FJX-06FJX-34
10	2	621520	BOOM HINGE FOLD CYL ASSY	30	1	616049	04C1T-06FJX-06FJX-26
11	1	615767	BOOM EXTN LOWER HYD TUBE ASSY	31	2	611206	04C1T-06FJX-06FJX-66
12	1	615761	LIFT RAISE HYD TUBE ASSY	32	5	616026	04C1T-06FJX-06FJX-37
13	1	615762	LIFT LOWER HYD TUBE ASSY	33	1	616037	04C1T-06FJX-06FJX-29
14	1	615763	LEVEL RAISE HYD TUBE ASSY	34	1	614713	04C1T-06FJX-06FJX-24
15	1	615764	LEVEL LOWER HYD TUBE ASSY	35	1	614712	04C1T-06FJX-06FJX-20
16	1	615766	BOOM EXTN RAISE HYD TUBE ASSY	36	14	618119	9/16MJIC-90-9/16MOR LBO
17	1	615768	RH FOLD RAISE HYD TUBE ASSY	37	14	619010	9/16MJIC UNION
18	1	615769	RH FOLD LOWER HYD TUBE ASSY	38	1	615314	04C1T-06FJX-06FJX-50
19	4	615684	HYD TUBE ASSY, BOOM EXT FOLD96	39	2	618320	9/16MJIC UNION CROSS
20	6	614750	.042 ELBOW ASSY, 9/16MOR 90D	40	4	618019	9/16MJIC UNION TEE

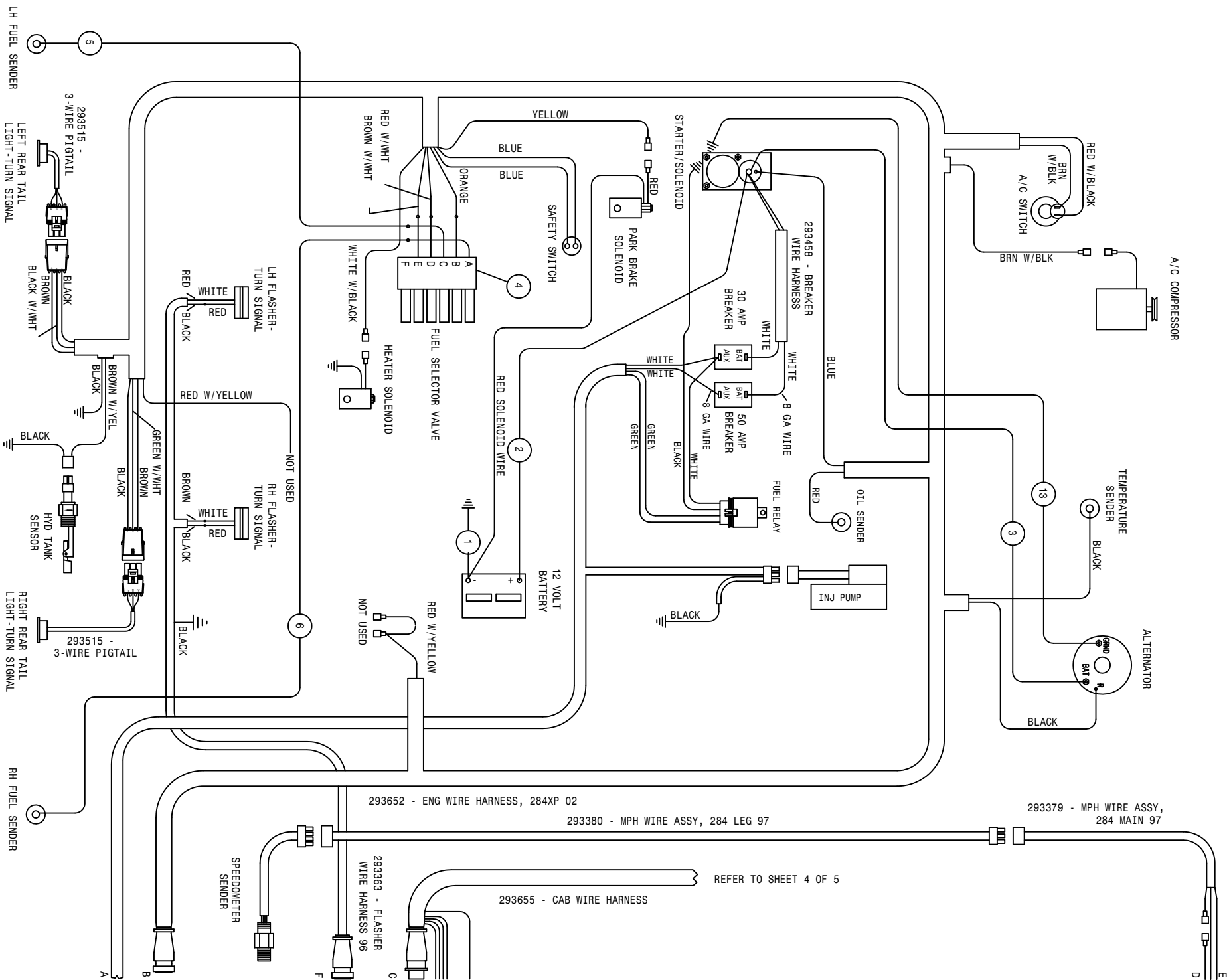



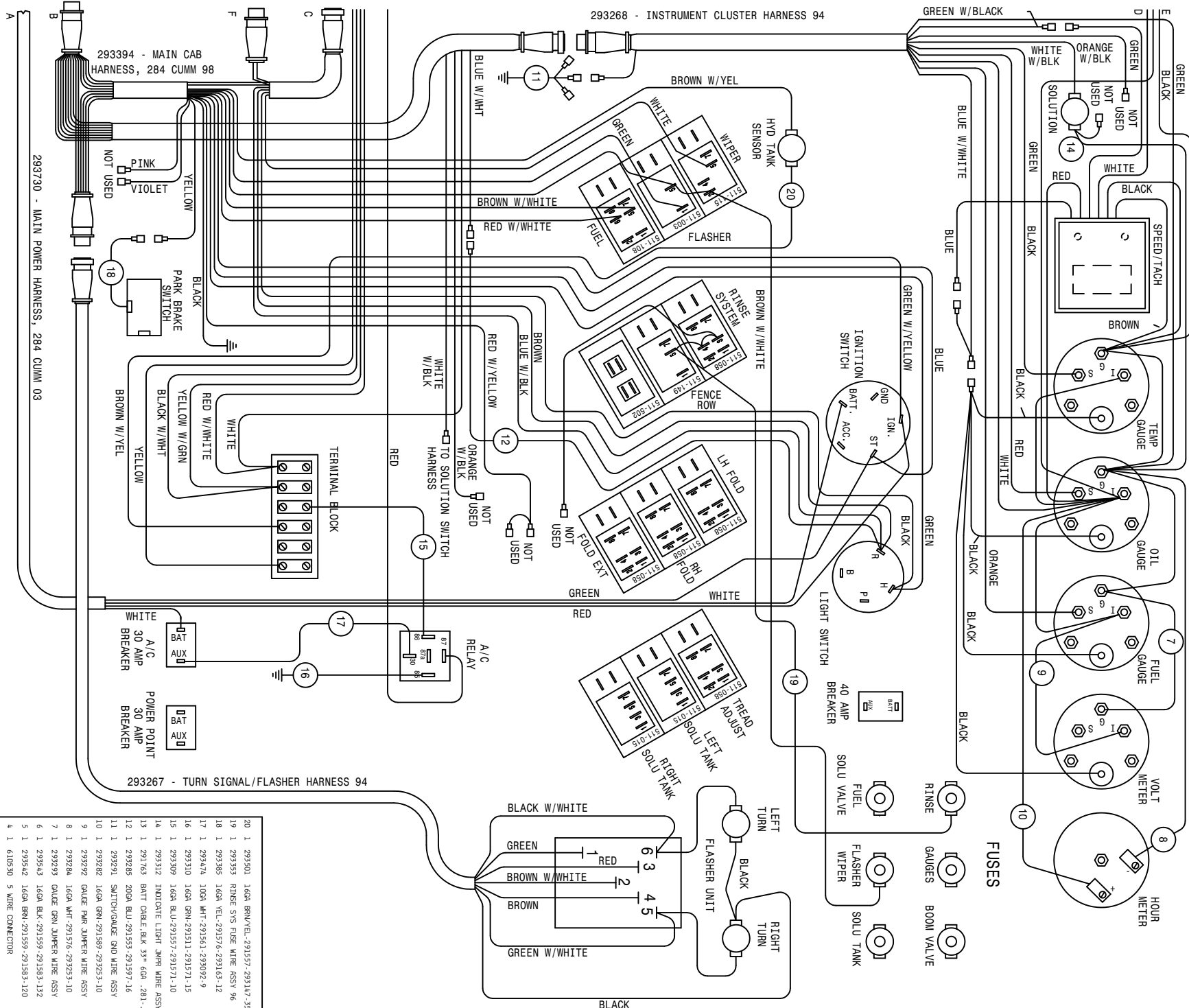

20	1	293501	1.6GA BRN/YEL-291557-293147-25
19	1	293533	RINSE SYS FUSE WIRE ASSY 96
18	1	293385	1.6GA YEL-291576-293163-12
17	1	293474	1.0GA WHT-291561-293092-9
16	1	293310	1.6GA GRN-291511-291571-15
15	1	293309	1.6GA BLU-291557-291571-10
14	1	293232	INDICATE LIGHT 3MR WIRE ASSY
13	1	291765	BATT CABLE, BLK 37" 6GA, 281-, 406
12	1	293285	20GA BLU-291553-291597-16
11	1	293291	SWTGH/GAUGE GND WIRE ASSY
10	1	293282	1.6GA GRN-291589-293253-10
9	1	293292	GAUGE PAR. JUMPER WIRE ASSY
8	1	293284	1.6GA WHT-291576-293253-10
7	1	293293	GAUGE GRN JUMPER WIRE ASSY
6	1	293543	1.6GA BLK-291559-291583-132
5	1	293542	1.6GA BRN-291559-291583-120
4	1	610530	5 WIRE CONNECTOR
3	1	291700	BATT CABLE, RED 31" 6GA 1/4-7/8
2	1	291128	BATTERY CABLE, 48IN
1	1	291530	BATTERY GROUND CABLE 23

284XP CUMM WIRING DIAGRAM 04  
 SHEET 1 OF 5  
 REVISION DATE:  
 498835

SOLUTION SOLENOID VALVES

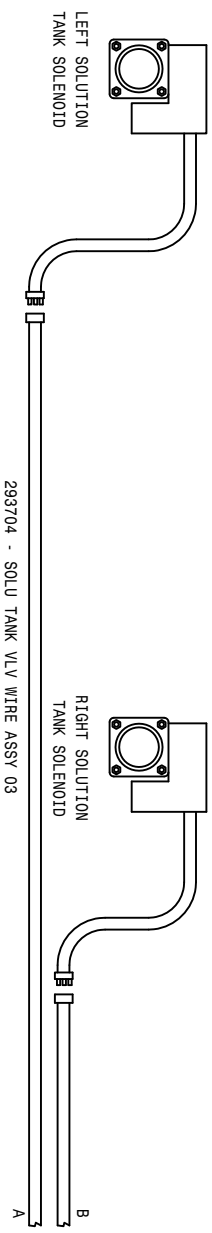
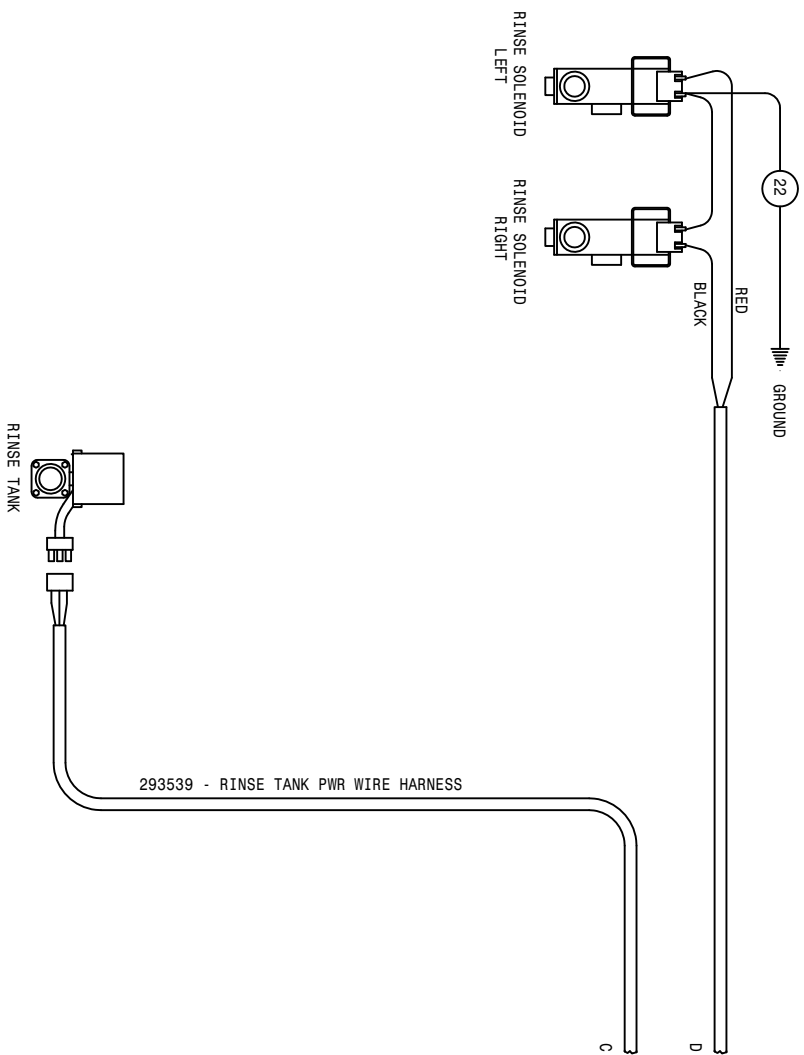

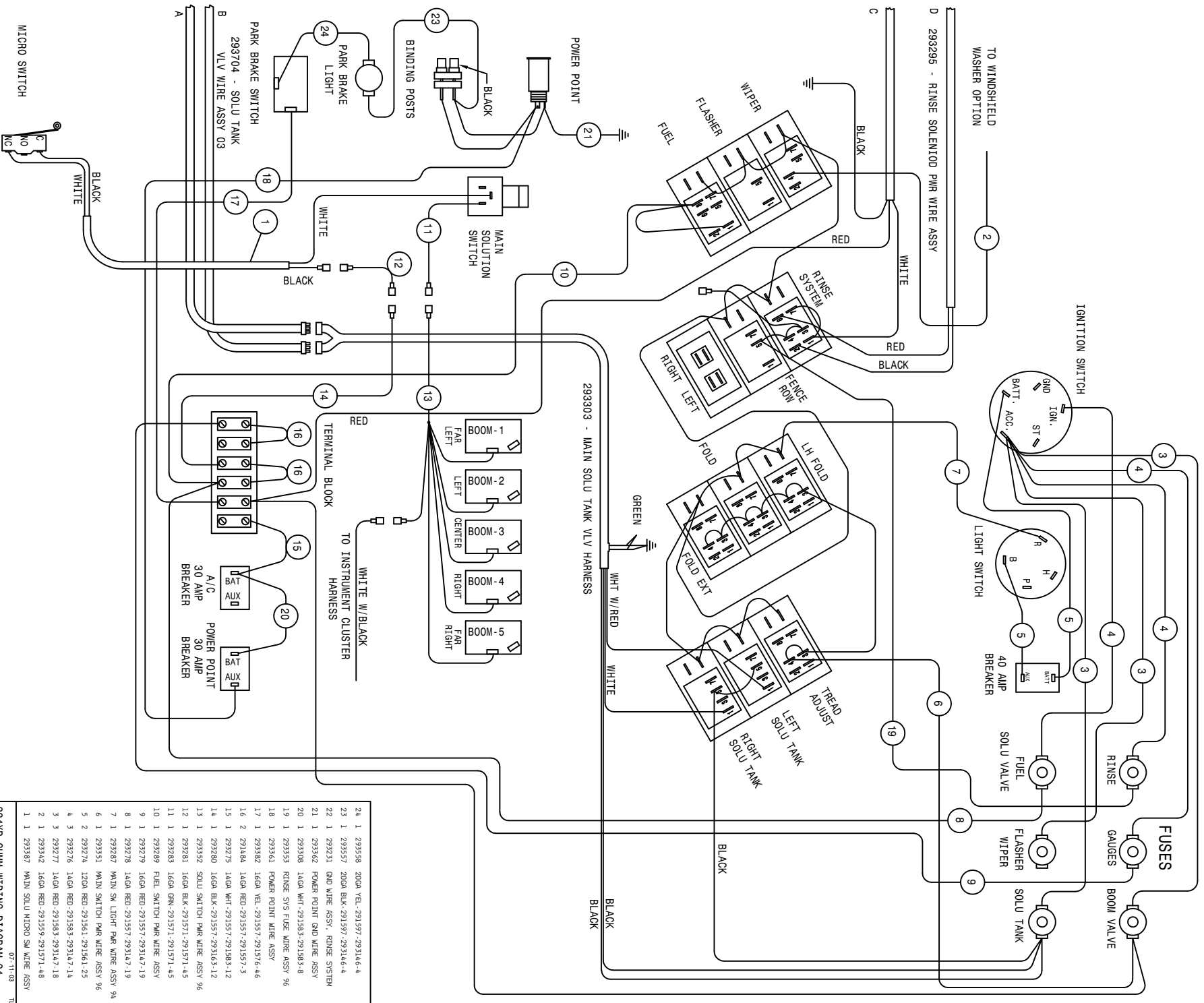

PARK BRAKE SWITCH  
293704 - SOLU TANK  
V.LV WIRE ASSY 03

MICRO SWITCH

24	1	293558	20GA YEL.-291597-293146-4
23	1	293557	20GA BLK.-291597-293146-4
22	1	293231	GND WIRE ASSY, RINSE SYSTEM
21	1	293562	POWER POINT GND WIRE ASSY
20	1	293308	14GA WHT.-291583-291583-8
19	1	293353	RINSE S/S FUSE WIRE ASSY 96
18	1	293361	POWER POINT WIRE ASSY
17	1	293382	16GA YEL.-291557-291576-4/6
16	2	291484	14GA RED.-291557-291571-3
15	1	293275	16GA WHT.-291557-291583-12
14	1	293280	16GA BLK.-291557-293145-12
13	1	293352	SOLU SWITCH PWR WIRE ASSY 96
12	1	293281	16GA BLK.-291571-291571-4/5
11	1	293283	16GA GRN.-291571-291571-4/5
10	1	293289	FUEL SWITCH PWR WIRE ASSY
9	1	293279	16GA RED.-291557-293147-1/9
8	1	293287	16GA RED.-291557-293147-1/9
7	1	293287	MAIN SM LIGHT PWR WIRE ASSY 94
6	1	293351	MAIN SWITCH PWR WIRE ASSY 96
5	2	293274	12GA RED.-291561-291561-2/5
4	3	293276	14GA RED.-291583-293147-1/4
3	3	293277	14GA RED.-291583-293147-1/8
2	1	293342	16GA RED.-291559-291571-4/8
1	1	293387	MAIN SOLU MICRO SM WIRE ASSY

284XP CUMM WIRING DIAGRAM 04  
07-11-03 TLU  
SHEET 2 OF 5  
REVISION DATE:  
498835

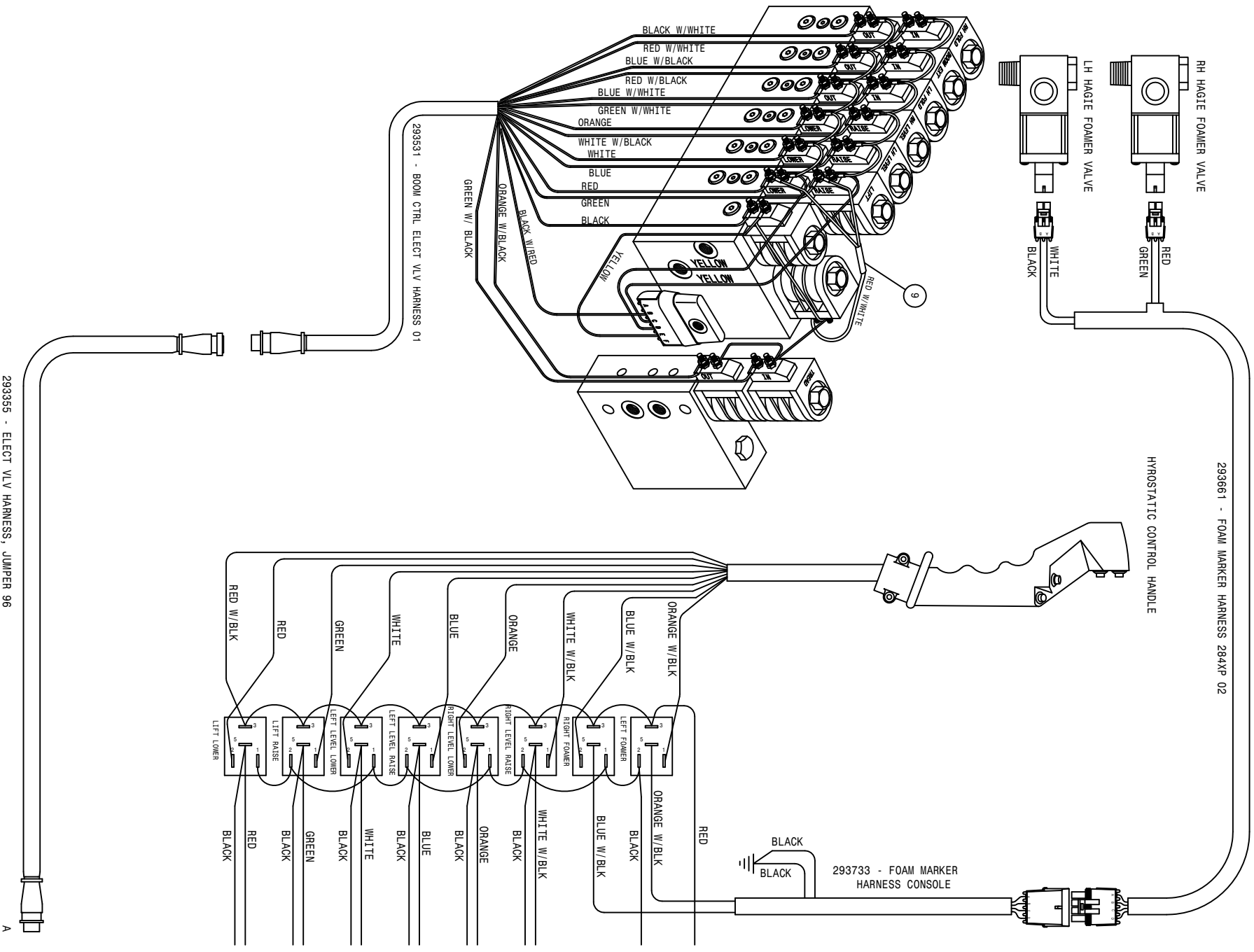

293385 - ELECT VLV HARNESS, JUMPER 96

A

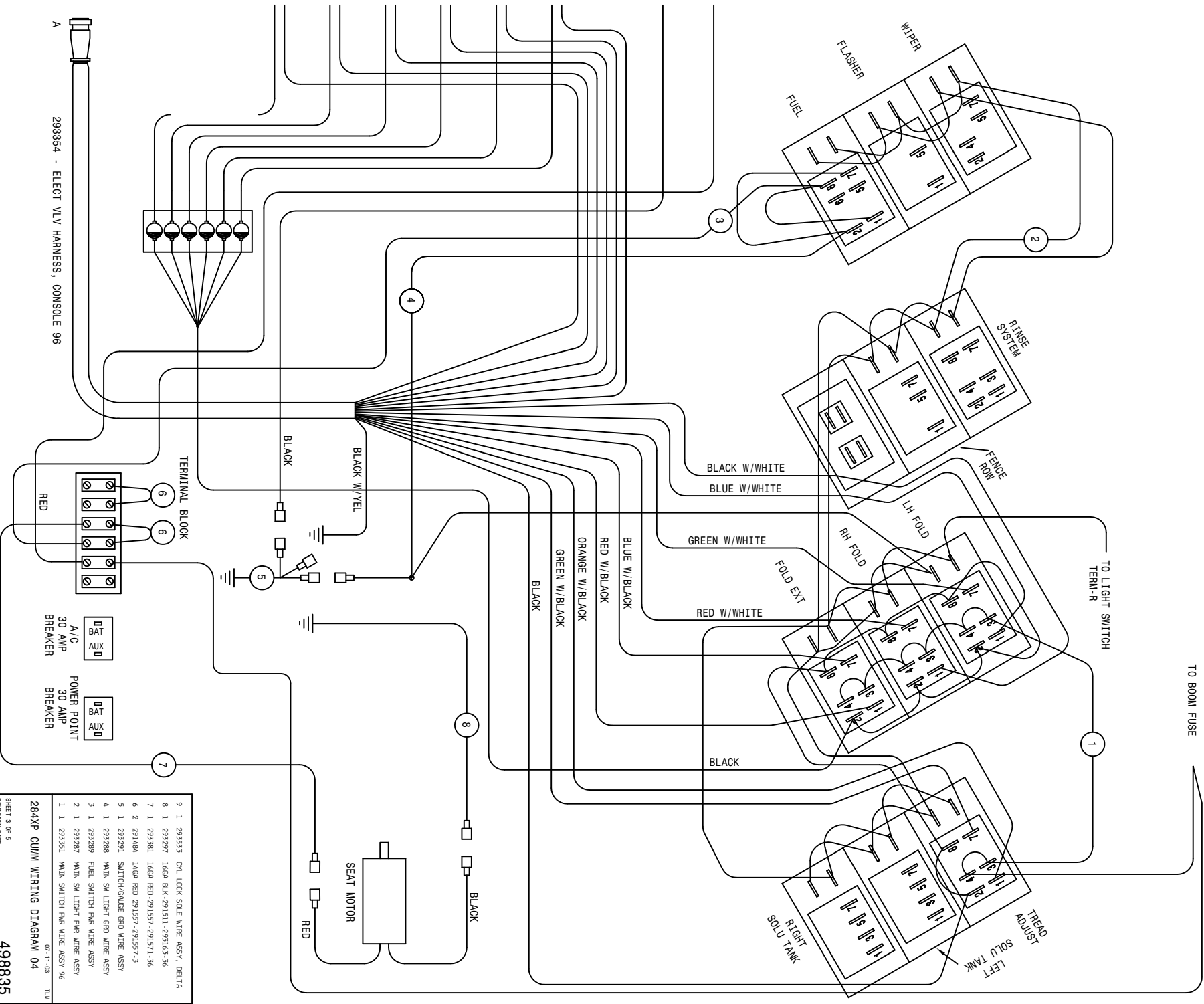

293354 - ELECT VLV HARNESS, CONSOLE 96

RED

A/C  
BAT  
AUX

30 AMP  
BREAKER

POWER POINT  
BAT  
AUX

30 AMP  
BREAKER

TERMINAL BLOCK

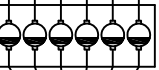

BLACK

BLACK W/YEL

4

8

BLACK

SEAT MOTOR

RED

TO BOOM FUSE

TO LIGHT SWITCH  
TERM-R

1

2

RINSE  
SYSTEM

FENCE  
ROW

WIPER

FLASHER

FUEL

3

BLACK W/WHITE  
BLUE W/WHITE

GREEN W/WHITE  
RED W/WHITE

BLUE W/BLACK  
RED W/BLACK  
ORANGE W/BLACK  
GREEN W/BLACK  
BLACK

BLACK

RIGHT TANK  
SOLV

LEFT TANK  
SOLV

TREAD  
ADJUST

9	1	293353	CYL LOCK SOLE WIRE ASSY, DELTA
8	1	293297	16GM BLK-2931511-293163-36
7	1	293361	16GM RED-291557-291571-36
6	2	291484	16GM RED 291557-291557-3
5	1	293291	SWITCH/GAUGE GRD WIRE ASSY
4	1	293288	MAIN SM LIGHT GRD WIRE ASSY
3	1	293289	FUEL SWITCH PWR WIRE ASSY
2	1	293287	MAIN SM LIGHT PWR WIRE ASSY
1	1	293351	MAIN SWITCH PWR WIRE ASSY 96

284XP CUMM WIRING DIAGRAM 04  
07-11-00  
TLH

498835

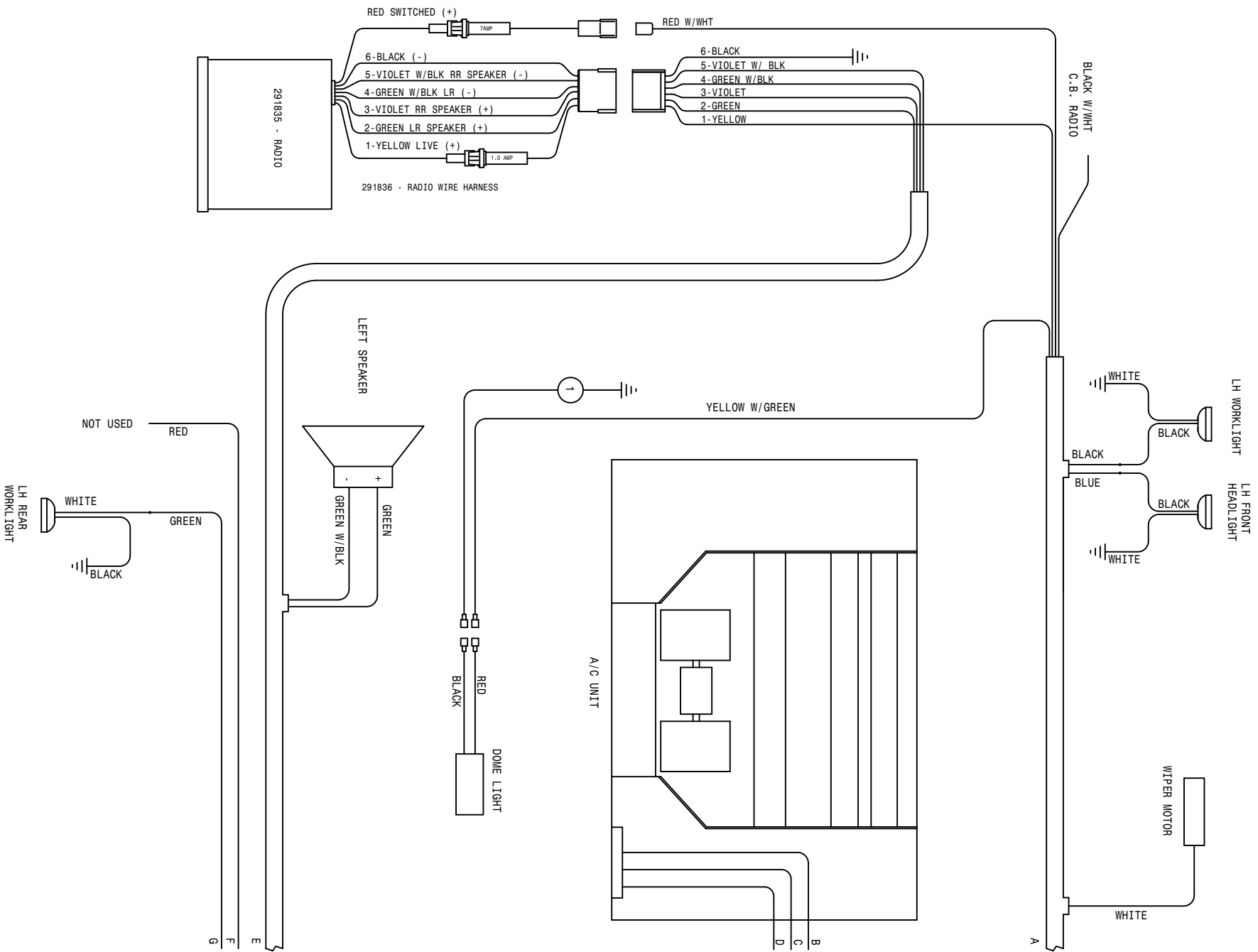

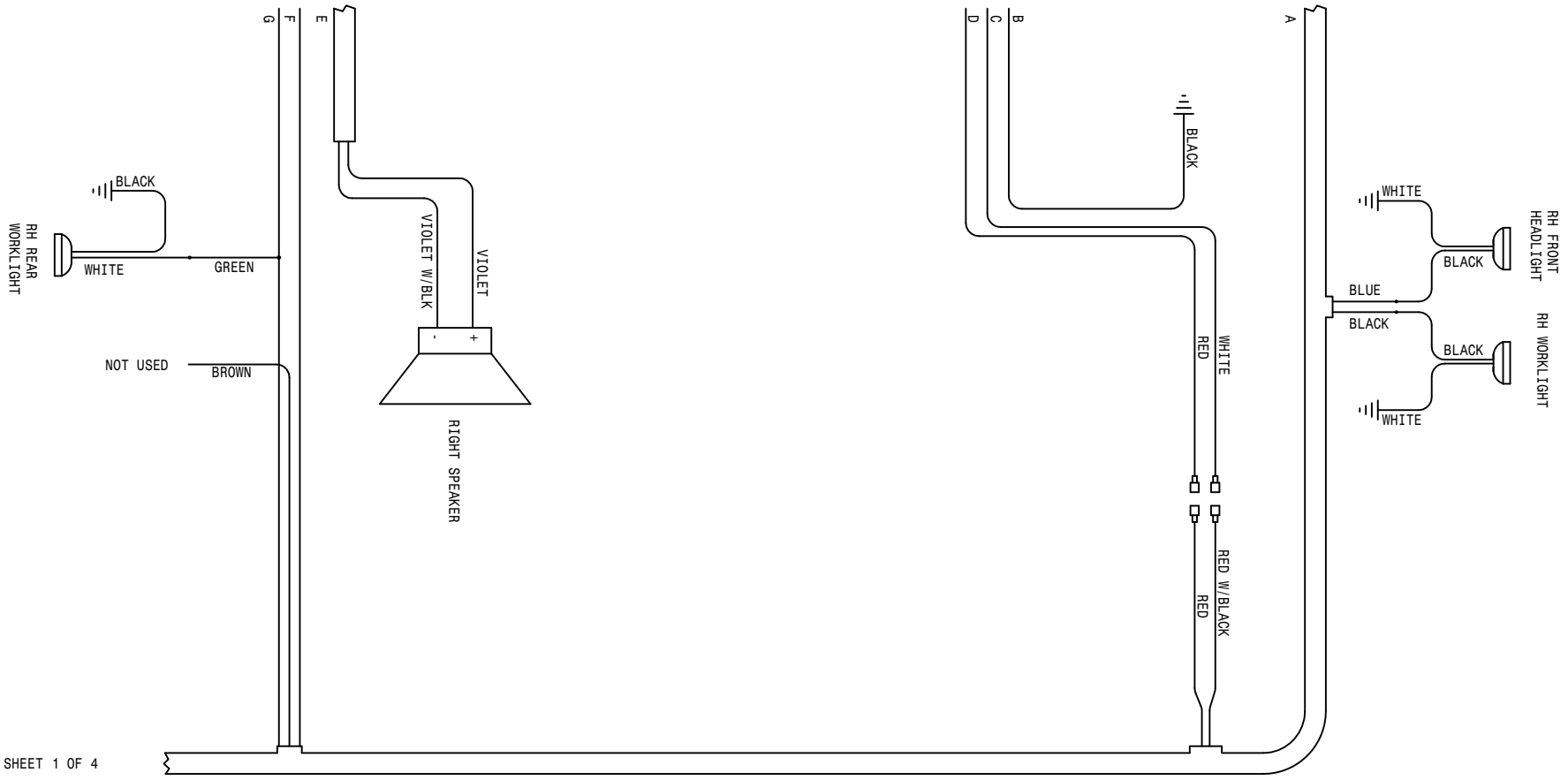

293655 - CAB WIRE HARNESS

REFER TO SHEET 1 OF 4

1	1	293299	16GA BLK-291511-291571-30	07-11-08	TLM
294XP CUMM WIRING DIAGRAM 04					
SHEET 4 OF 5					
REVISION DATE:					
<b>498835</b>					

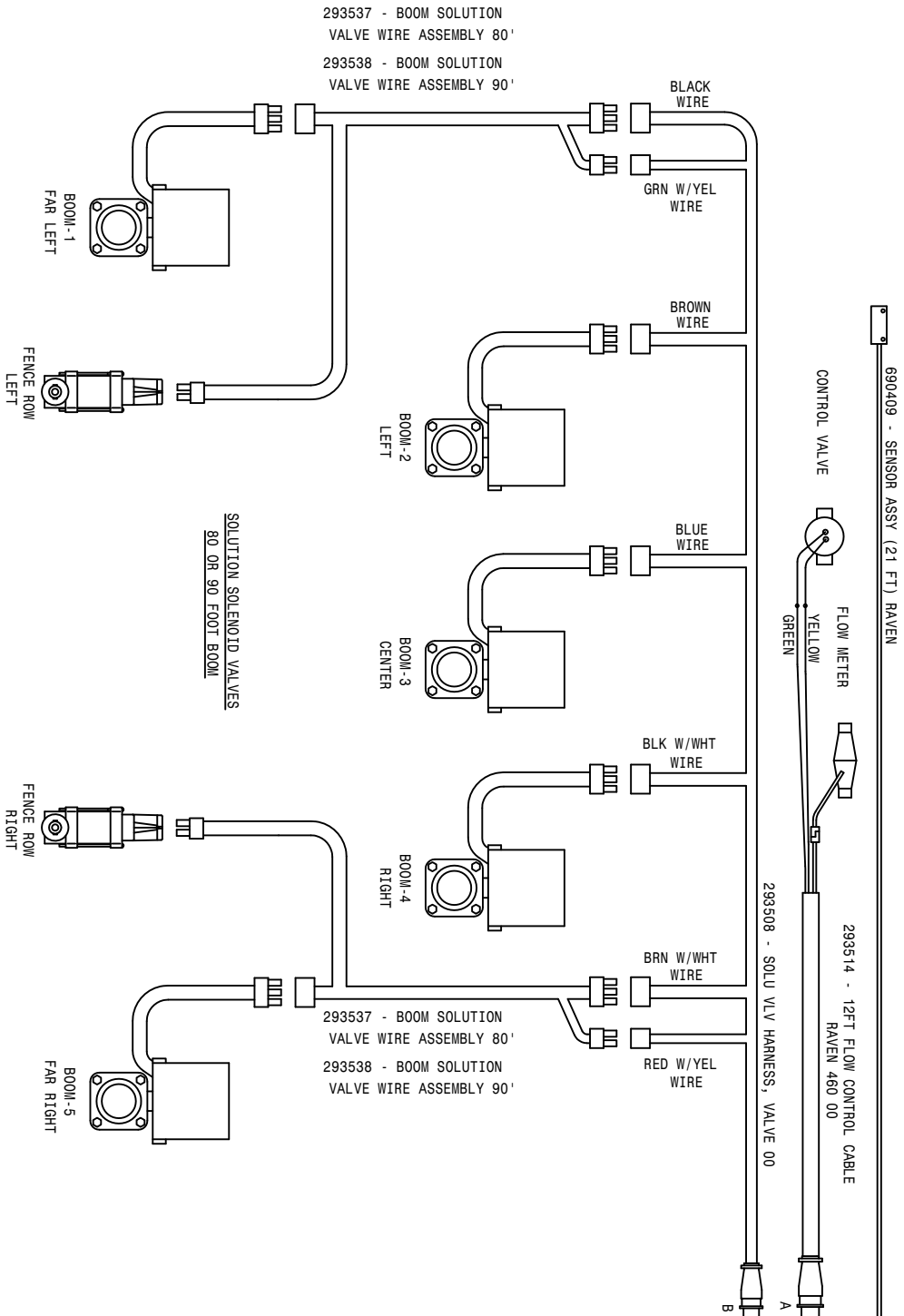
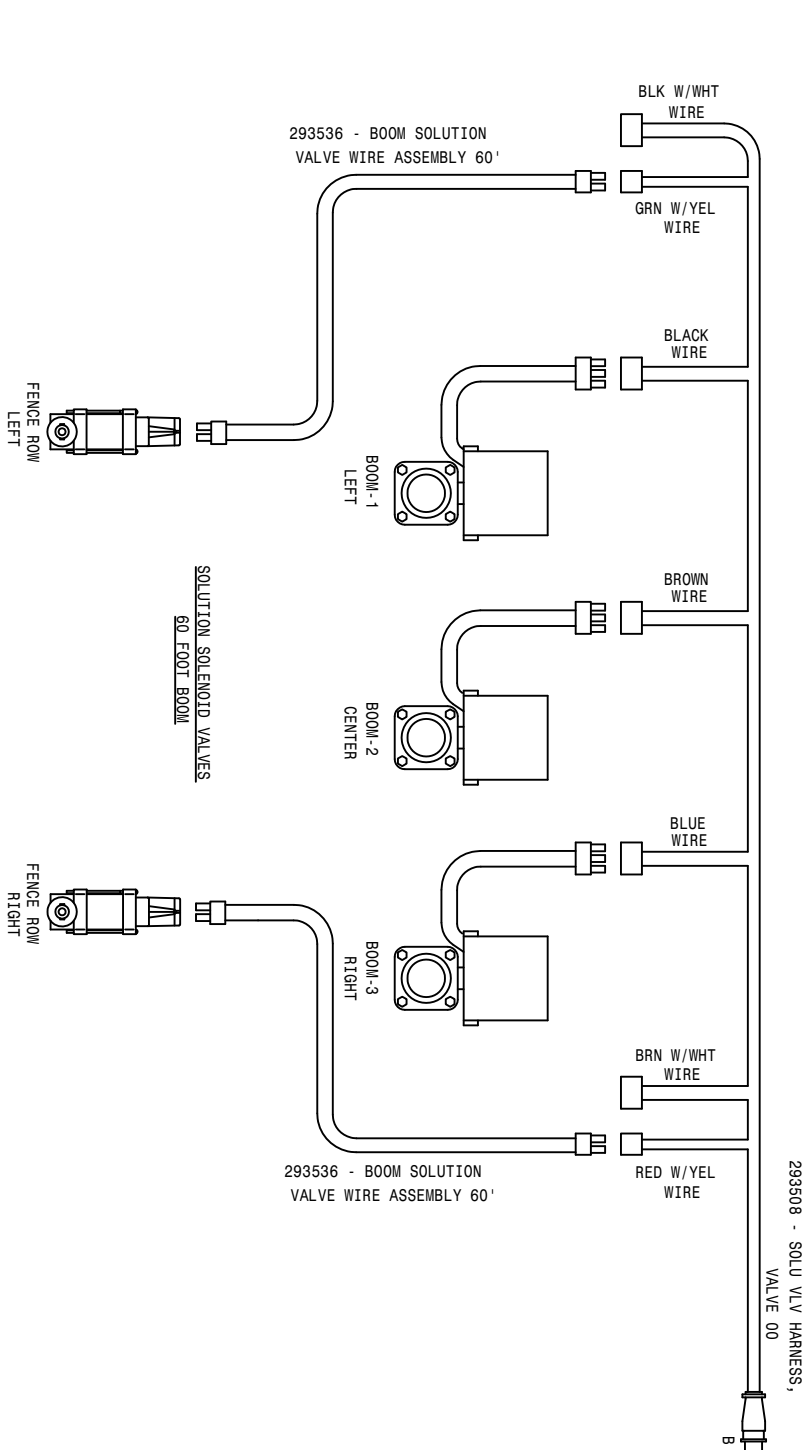



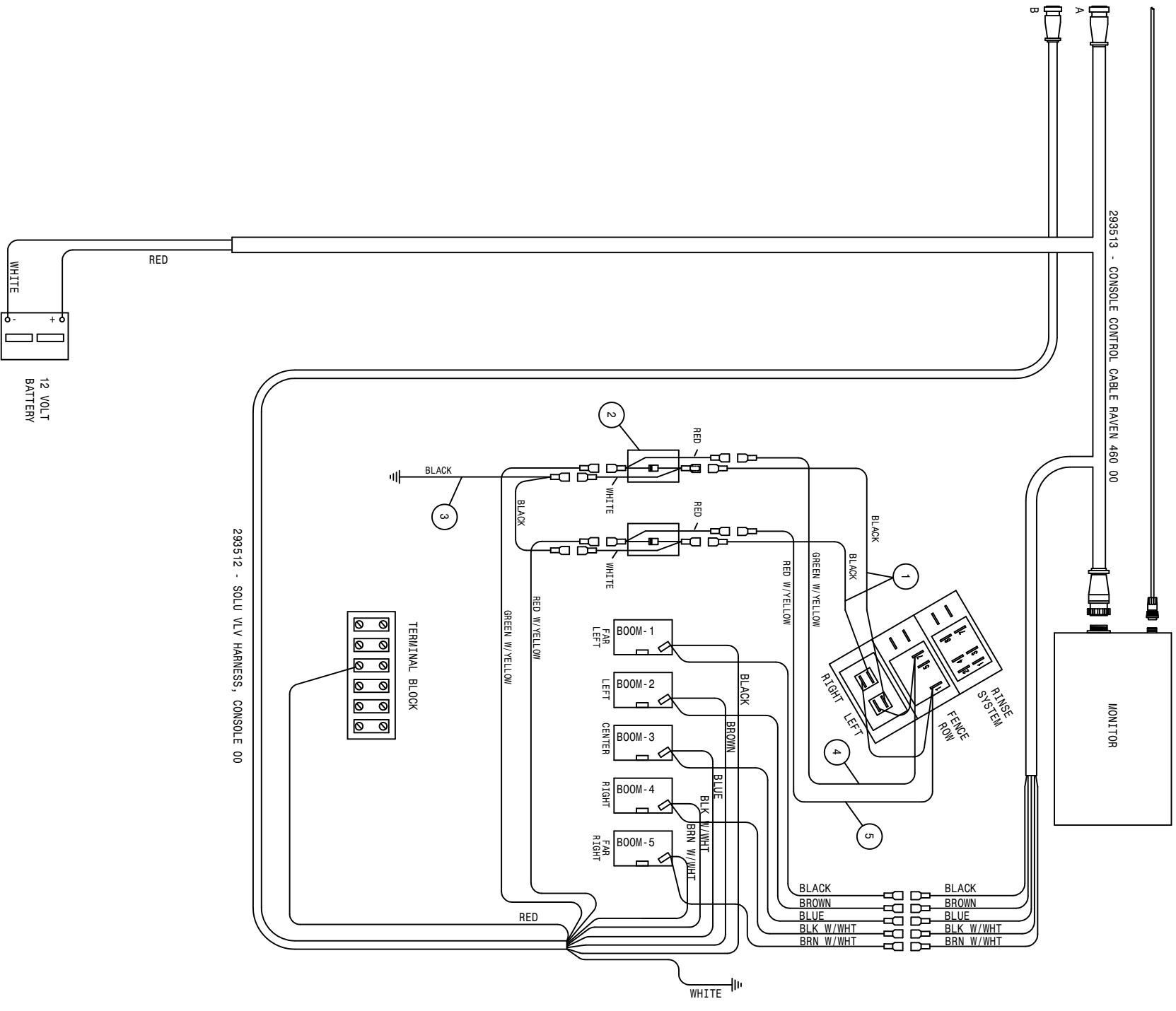

5	1	293470	RH FENCE ROW SWITCH WIRE
4	1	293471	LH FENCE ROW SWITCH WIRE
3	1	293472	FENCE ROW SWITCH GND WIRE
2	2	293317	DIODE SHUNT CABLE ASSY
1	2	293469	16GA BLK-291571-291571-11

284XP CUHM WIRING DIAGRAM 04

07-11-03 TLM

SHEET 5 OF 5  
 REVISION DATE: 07-29-03  
 498835

ABBREVIATIONS

A/C - AIR CONDITIONER	MT - MOUNT
ADPTR - ADAPTER	MTR - MOTOR
AGI - AGITATOR	P/N - PART NUMBER
ALT - ALTERNATOR	PLT - PLATE
ASSY - ASSEMBLY	QTY - QUANTITY
BRKT - BRACKET	RED - REDUCER
DET - DETAIL	REF - REFERENCE
DISPL - DISPLACEMENT	REST - RESTRICTOR
EL - ELBOW	REQ - REQUIRED
EXT - EXTENSION	SHFT - SHAFT
FLO - FLOW	SOL - SOLUTION
FNPT - FEMALE NATIONAL PIPE THREAD	STRG - STEERING
FOR - FEMALE O-RING	ST - STREET
FRT - FRONT	SWIV - SWIVEL
HYD - HYDRAULIC	UNC - UNIFIED NATIONAL COURSE
HYDRO - HYDROSTATIC	UNF - UNIFIED NATIONAL FINE
LG - LONG	V - VOLT
LWR - LOWER	W/ - WITH
MJIC - MALE J.I.C.	WHL - WHEEL
MOR - MALE O-RING	WLD - WELDMENT

INDEX

-A-

ABBREVIATIONS.....114  
 ACCUMULATOR CYLINDER.....78,79  
 ADJUSTMENT, TREAD.....90  
 AGITATOR  
     IMPELLER.....57,59  
     SHAFT.....57,59  
     SHIELD.....57,59  
     SOLUTION.....57,59  
 AIR CLEANER.....14  
     BAND.....14  
     FILTER.....14  
     HOOD.....14  
     HOSE.....14  
 AIR CONDITIONER  
     BLOWER MOUNT.....30  
     COMPRESSOR.....12  
     COMPRESSOR MOUNT.....12  
     CONDENSOR.....12  
     CONTROL.....30  
     DRYER.....12  
     FILTER.....30  
     AIR SEAT.....39  
     AIR TANK.....8,9  
     ANTENNA, RADIO.....30  
     ARM,  
         TANK SUPPORT.....55  
     WIPER.....28

-B-

BALL VALVE.....56,58  
 BAND,  
     AIR CLEANER.....14  
     FUEL TANK.....48  
     TANK.....56,58  
 BATTERY.....15  
     BOX.....15  
     CABLE.....15  
     BELT.....5,12  
     BINDING POST.....40  
     BLADE,  
         FAN.....5  
         WIPER.....28  
     BLOCK, TERMINAL.....35  
     BOOM.....84,85,86,87,88  
         CONTROL VALVE.....75  
         GRADLE.....43  
         PIVOT PIN.....77  
         SPRING.....85,87  
     BRACE,  
         LADDER.....46,47

LEG.....55  
 BRAKE SOLENOID.....38  
 BREAKAWAY.....77  
 BREAKER, CIRCUIT.....35  
 BREATHER.....16

-C-

CAB.....28  
     ROOF.....28  
 CABLE,  
     BATTERY.....15  
     CONTROL.....35,36,37,42  
     THROTTLE.....4  
     4WD.....41  
 CAP,  
     FUEL.....48  
     RADIATOR.....13  
     STEERING.....32  
     CATWALK.....49  
     CHECK VALVE.....61  
     CIRCUIT BREAKER.....35  
     COMPRESSOR, A/C.....12  
     CONDENSOR.....12  
     MOUNT.....12  
     CONSOLE.....35  
     COVER.....34  
     CONTROL HANDLE.....36  
     COOLER, OIL.....13  
     GRADLE.....56,58  
     BOOM.....43  
     CROP GUIDE.....19,21,23,25  
     CYLINDER,  
         ACCUMULATOR.....78,79  
         FOLD.....82  
         LEVEL.....81  
         LIFT.....80  
         STEERING.....26  
         TREAD ADJUSTMENT.....92

-D-

DECALS.....96,97  
 DIAGRAM, WIRING.....104  
 DIFFUSER, LINE SUMP.....16  
 DIMMER SWITCH.....28  
 DIPSTICK.....16

DOOR.....29  
HANDLE.....29  
DRINK HOLDER.....35  
DRIVE ASSEMBLY.....4  
DRYER, A/C.....12

-E-

ELECT SOLENOID VLV 61,62,63,68,69  
ENGINE.....4,5  
HOOD.....44  
MOUNTS.....4,5  
EXHAUST PIPE.....14

-F-

FAN  
BLADE.....5  
SPACER.....5  
FILTER,  
AIR CLEANER.....14  
AIR CONDITIONER.....30  
FUEL.....4  
HI-PRESS.....11  
INLINE HYDRAULIC.....75  
MICHIGAN.....16  
MINDER.....33  
OIL.....5,16  
FLASHER LIGHT.....43  
FLASHER SWITCH.....32  
FLOORMAT.....31  
FLOW CONTROL  
VALVE.....61,62,68,69  
VARIABLE.....42  
FLOW DIVIDER.....7  
FLOW METER.....61,62,68,69  
FLUSHING VALVE.....10  
FOAM.....13,31  
FOAMER TANK.....51  
FOLD CYLINDER.....77,82,83  
FUEL  
CAP.....48  
GAUGE.....33  
SELECTOR VALVE.....48  
SENDER.....48  
TANK.....48  
FUSE.....34  
HOLDER.....34

-G-

GAUGE,  
FUEL.....33  
OIL PRESSURE.....33  
PRESSURE.....61,62,68,69  
SIGHT.....46,58

TEMPERATURE.....33  
GAS SPRING.....29  
GLASS.....28,29  
GLAND PACKING.....57,59  
GRAB HANDLE.....28  
GROUND STRAP.....4,15,28  
GUARD, SPRING.....64,65,66,67  
GUIDE, CROP.....19,21,23,25

-H-

HANDLE,  
CONTROL.....36  
DOOR.....29  
GRAB.....28  
HANDRAIL.....44,49  
HEADLIGHT.....28  
HEADLINER.....30  
HEAT SHIELD.....13  
HI-PRESS  
FILTER.....11  
HOLDER, DRINK.....35  
HOOD,  
AIR CLEANER.....14  
ENGINE.....44  
HOOK, RUBBER.....44  
HOSE, AIR CLEANER.....14  
HOSING, SOLUTION.....64,65,66,67  
HOUR METER.....33  
HUB, TORQUE.....19,21,23,25  
HYDRAULIC  
SCHEMATIC.....98  
TANK.....16  
TUBE.....19,21,23,25,76,85

-I-

IMPELLER.....57,59  
INDICATOR, MPH-RPM.....33  
INLINE HYDRAULIC FILTER.....75  
INTERIOR LIGHT.....30

-K-

KICK PANEL.....28  
KNOB.....34,35

-L-

LADDER.....46,47  
BRACE.....47  
LEG,  
BRACE.....55  
FRONT.....18,19,20,21  
REAR.....22,23,24,25  
LEVEL CYLINDER.....77,81

LEVER,  
 HYDROSTATIC.....36  
 THROTTLE.....37  
 LID.....56, 58, 53  
 LIFTARM.....76  
 MOUNT.....76  
 LIFT CYLINDER.....76, 79  
 LIGHT,  
 HEAD.....28  
 INTERIOR.....30  
 SWITCH.....34  
 TURN SIGNAL.....43  
 LINE SUMP DIFFUSER.....16

-M-

METER, HOUR.....33  
 MIRROR.....28  
 MOTOR  
 STEERING.....32  
 WHEEL.....19, 21, 23, 25  
 WIPER.....28  
 MOUNT,  
 A/C BLOWER.....30  
 CONDENSOR.....12  
 ENGINE.....4, 5  
 FLOW DIVIDER.....7  
 LIFTARM.....76  
 MONITOR.....40  
 RADIATOR.....13  
 RUBBER.....4, 5, 28  
 SOLUTION VFC.....42  
 TANK.....55  
 MUFFLER.....14  
 MULLION.....44

-N-

NOZZLE,  
 FENCE ROW.....72, 73  
 REAR WHEEL.....89  
 RINSE.....54  
 NYLON SLEEVE.....18, 20, 22, 24

-O-

OIL  
 COOLER.....13  
 FILTER.....5  
 PRESSURE GAUGE.....33  
 SENDER.....4  
 TANK.....16

-P-

PANEL, KICK.....28  
 PARK BRAKE SWITCH.....40  
 PIVOT PIN, BOOM.....77  
 PLATFORM, SERVICE.....49  
 POWER POINT.....40  
 PRESSURE GAUGE.....61, 62, 68, 69  
 PRESSURE WASHER.....93, 94  
 PUMP,  
 SOLUTION.....61  
 SUNDSTRAND.....6

-R-

RADIATOR.....13  
 CAP.....13  
 HOSE.....5  
 MOUNT.....13  
 SCREEN.....13  
 SHROUD.....13  
 RADIO.....30  
 RECOVERY.....13  
 RELAY.....36  
 RELIEF VALVE.....7  
 RIM.....17  
 RINSE,  
 NOZZLE.....54  
 TANK.....53  
 ROOF, CAB.....28  
 RUBBER,  
 HOOK.....45  
 MOUNT.....4, 5, 28  
 WASHER.....7, 41

-S-

SCHEMATIC, HYDRAULIC.....98  
 SCREEN.....45  
 RADIATOR.....13  
 SEAT.....39  
 SELECTOR VALVE, FUEL.....48  
 SENDER,  
 FUEL.....48  
 OIL.....4  
 TEMPERTURE.....5  
 SERVICE PLATFORM.....49  
 SHAFT, AGITATOR.....57, 59  
 SHEETMETAL.....44, 45  
 SHIELD,  
 AGITATOR.....57, 59  
 HEAT.....13  
 SIDE.....45  
 TANK.....55  
 WHEEL MOTOR.....19, 21, 23, 25  
 SHROUD, RADIATOR.....13

SIGHT GAUGE.....56,58  
 SMV SIGN.....49  
 SOLUTION  
 AGITATOR.....57,59  
 HOISING.....64,65,66,67  
 PUMP.....61  
 TANK.....56,58  
 SPACER, FAN.....5  
 SPEAKER.....30  
 SPRING.....37  
 BOOM.....85,87  
 GUARD.....64,65,66,67  
 STALK GUIDE.....19,21,23,25  
 STEERING  
 ARM.....18,20,22,24  
 CAB.....32  
 CYLINDER.....26  
 MOTOR.....32  
 POST.....32  
 WHEEL.....32  
 STRAINER.....56,58  
 STRAP, GROUND.....4,15,28  
 SUNDSTRAND PUMP.....6  
 SUPPORT ARM.....55  
 SWITCH  
 DIMMER.....28  
 FLASHER.....32  
 LIGHT.....34  
 PARK BRAKE.....40  
 TOGGLE.....34

-T-

TAILLIGHT.....49  
 TANK,  
 AIR.....8,9  
 BAND.....56,58  
 FOAMER.....51  
 FUEL.....48  
 HYDRAULIC OIL.....16  
 LID.....53,56,58  
 MOUNTS.....55  
 RECOVERY.....13  
 RINSE.....53  
 SHIELD.....55  
 SOLUTION.....56,58  
 TEMPERATURE  
 GAUGE.....33  
 SENDER.....5  
 TERMINAL BLOCK.....35  
 THROTTLE  
 CABLE.....4  
 LEVER.....37  
 TIE ROD.....27  
 TIRE.....17

TOGGLE SWITCH.....34  
 TORQUE HUB.....19,21,23,25  
 TRANSOM.....77  
 TREAD ADJUSTMENT.....90  
 CYLINDER.....92  
 TUBE,  
 HYDRAULIC.....76,85  
 4WD.....41  
 TURN SIGNAL LIGHT.....43

-V-

VALVE,  
 BALL.....56,58  
 BOOM CONTROL.....61,62,68,69  
 CHECK.....61  
 ELECTRIC SOLUTION.....56,58  
 FLOW CONTROL.....61,62,68,69  
 FLUSHING.....10  
 RELIEF.....7  
 SOLUTION SOLENOID.....61,62,68,69  
 4WD.....41  
 VARIABLE FLOW CONTROL.....42  
 VOLTMETER.....33

-W-

WASHER, PRESSURE.....93,94  
 WEATHER STRIP, WINDOW.....28,29  
 WHEEL MOTOR.....19,21,23,25  
 SHIELD.....19,21,23,25  
 WHEEL, STEERING.....32  
 WINDSHIELD WASHER.....74  
 WIPER  
 ARM.....28  
 BLADE.....28  
 MOTOR.....28  
 WIRING DIAGRAM.....104



# PARTS ORDER FAX



Ph. 1 (800) 247-4885    Fx. 1 (515) 532-3553

Photocopy and fax to Hagie Customer Support Department

**ORDERED BY/BILL TO:**

Name \_\_\_\_\_  
 Co. Name \_\_\_\_\_  
 Street \_\_\_\_\_  
 City, St, Zip \_\_\_\_\_  
 Ph. \_\_\_\_\_ Fx. \_\_\_\_\_

**SHIP TO:**

Name \_\_\_\_\_  
 Co. Name \_\_\_\_\_  
 Street \_\_\_\_\_  
 City, St, Zip \_\_\_\_\_  
 Ph. \_\_\_\_\_ Fx. \_\_\_\_\_

HOW SHIP:    UPS Ground    Next Day    2 Day    3 Day    Other \_\_\_\_\_

If "HOW SHIP" is left blank, parts will be sent UPS ground service. If part is over 150 pounds, an independent motor freight company will be used.

**PAYMENT:**    Hagie Account #\*\*\* \_\_\_\_\_

C.O.D

American Express    Discover    Visa    Master Card  
 Signature: \_\_\_\_\_  
 name as appears on card: \_\_\_\_\_  
 card no. \_\_\_\_\_ exp. date \_\_\_\_\_

Year and Model No. \_\_\_\_\_

Serial No. \_\_\_\_\_

Item Serial No. (if necessary): \_\_\_\_\_

Engine (include type) \_\_\_\_\_  
 Hydrostatic Pump (s) \_\_\_\_\_  
 Torque Hub \_\_\_\_\_       LF    RF    LR    RR  
 Wheel Motor \_\_\_\_\_       LF    RF    LR    RR

HAGIE Part No.	Qty.	Description

Check here if you want phone confirmation of parts order.

\* Orders received before 3:00 p.m., CST will be processed the same business day.  
 Regular business hours are Monday through Friday, 7:00 a.m. through 5:00 p.m..  
 \*\* If you do not have a Hagie account number, contact the Hagie Customer Support Department and you will be issued one.

