

PARTS MANUAL
FOR
HAGIE MODEL 284 HI-TRACTOR

HAGIE MANUFACTURING COMPANY

BOX 273 CLARION, IOWA 50525 (515) 532-2861

COVERS MACHINE SERIAL NUMBERS: 038099001 thru 038099100
038299001 thru 038299100

09-98 493191
02-08

SPRAYER IDENTIFICATION

Each Hagie sprayer is identified by means of a frame serial number. This serial number denotes the model, the year in which it was built, and the number of the sprayer. As for further identification, the engine has a serial number and the planetary hubs have identification plates that describe the type of mount and gear ratio. To insure prompt, efficient service when ordering parts or requesting service repairs from Hagie Manufacturing Company, record the serial and identification numbers in the space provided below.

NOTE: Reference to left hand and right hand used throughout this manual refers to the position when seated in the operator's seat facing forward.

SPRAYER SERIAL NUMBER

ENGINE SERIAL NUMBER

PLANETARY HUB IDENTIFICATION NUMBERS

TABLE OF CONTENTS

ENGINE ASSEMBLIES 4-6
FLOW DIVIDER AND FLUSHING VALVE 7-9
A/C AND RADIATOR 10-11
AIR CLEANER AND EXHAUST PIPE 12
BATTERY 13
LEG ASSEMBLIES 14-17
TIRE AND CROP GUIDES 18-19
LEG AND STEERING CYLINDER 20-21
TIE ROD ASSEMBLY 22-25
FUEL AND OIL TANKS 26-27
CAB ASSEMBLY 28-32
INSTRUMENT PANEL ASSEMBLY 33
SWITCH PANEL ASSEMBLY 34
CONSOLE ASSEMBLY 35-37
BRAKE SOLENOID AND SEAT 38-40
SELECTOR VALVE AND VFC 41-42
BOOM CRADLE 43
SHEET METAL 44-45
TANK SHIELDS 46-47
LADDER AND SERVICE PLATFORM ASSEMBLY 48
BOOM VALVE 49
TRANSOM, BOOM AND LIFT COMPONENTS 50-63
SOLUTION SYSTEM 64-75
RINSE OPTION 76-79
TREAD ADJUSTMENT OPTION 80-83
FOAMER OPTION 84-88
INJECTION PLATFORM 89
HYPRO D-230 OPTION 90-93
WINDSHIELD WASHER OPTION 94
CROPSHIELD 95
PRESSURE WASHER OPTION 96-97
INDUCTOR TANK AND 98-99
SOLUTION HOISING 100-101
HYDRAULIC SCHEMATIC 102-107
ELECTRICAL SCHEMATIC 108-117
DECALS 118-119
ABBREVIATIONS 120
INDEX 121

ENGINE ASSEMBLY

DET. QTY PART NO. DESCRIPTION

1	1	193012	QUICKEDGE TRIM .135 TO .250
2	1	290107	GROUND STRAP 8 IN
3	1	291674	OIL PRESS SENDER,125PSI,1/8NPT
4	1	316252	RH REAR ENG MT WLD, CUMM 94
5	1	316253	LH REAR ENG MT WLD, CUMM 94
6	1	316303	THROTTLE CABLE MT,6CYL CUMM 97
7	1	316304	THROTTLE LEVER EXT,6CYL CUMM97
8	1	316312	CUMM ENG,6B5.9A 152@2500 CMPSR
9	1	316320	HYDST CABLE MT WLD,284 CUMM 98
10	1	316322	AIR REGULATOR BRKT 98
11	8	473775	12MM-1.75 X 30MM HEX BOLT
12	12	473784	12MM LOCK WASHER
13	2	473826	6MM-1.00 X 16MM HEX BOLT
14	2	473828	12MM-1.50 X 20MM HEX BOLT
15	2	473783	12MM-1.75 X 25MM HEX BOLT
16	1	611147	3/4MJIC-1/2MNPT ADPTR
17	2	618447	7/16MJIC-90-1/8MNPT LBO
18	1	611293	04P919-04FJX-04FJX-20 H/A
19	1	711026	1/8MNPT-90-1/4OD NYL TUBE FTG
20	2	900072	5/16UNC X 3" HEX BOLT
21	2	914002	5/16UNC HEX STOVER NUT
22	2	920001	5/16 SAE FLAT WASHER
23	2	920500	1/4 LOCK WASHER
24	2	311054	RUBBER MOUNT SET, CB-2202-4
25	2	311055	REBOUND WASHER FOR 311054
26	1	520055	HOSE CLAMP NO 12 STAINLESS
27	4	520120	HOSE CLAMP NO 4 STAINLESS
28	1	316281	FUEL STRAINER, IN-LINE, DIESEL
29	1	601347	HOSE, 3/8 X 10" FUEL LINE
30	1	473921	BALL JOINT NO 10-32 THD
31	20	473798	10MM LOCK WASHER
32	2	910027	10-32 HEX NUT
33	1	785066	CTRL CABLE 10-32 4IN X 129 IN
34	1	316208	FUEL FILTER, PRIMARY CUMM 92
35	1	316209	FUEL FILTER, SECONDARY CUMM92
36	2	900271	1/2UNC X 3 1/4 HEX BOLT
37	2	914008	1/2UNC HEX STOVER NUT
38	2	920004	1/2 SAE FLAT WASHER
39	1	914027	10-32 HEX STOVER NUT
40	3	920510	#10 LOCK WASHER
41	1	903893	10-32 X 1" SLT RD HD MACH SCR
42	1	601394	HOSE, 1/4"OD X 34" AIR
43	1	800501	DRIVE DISK ASSY, 284 97
44	8	473793	10MM-1.50 X 20MM HEX BOLT
45	12	473792	10MM-1.50 X 30MM HEX BOLT

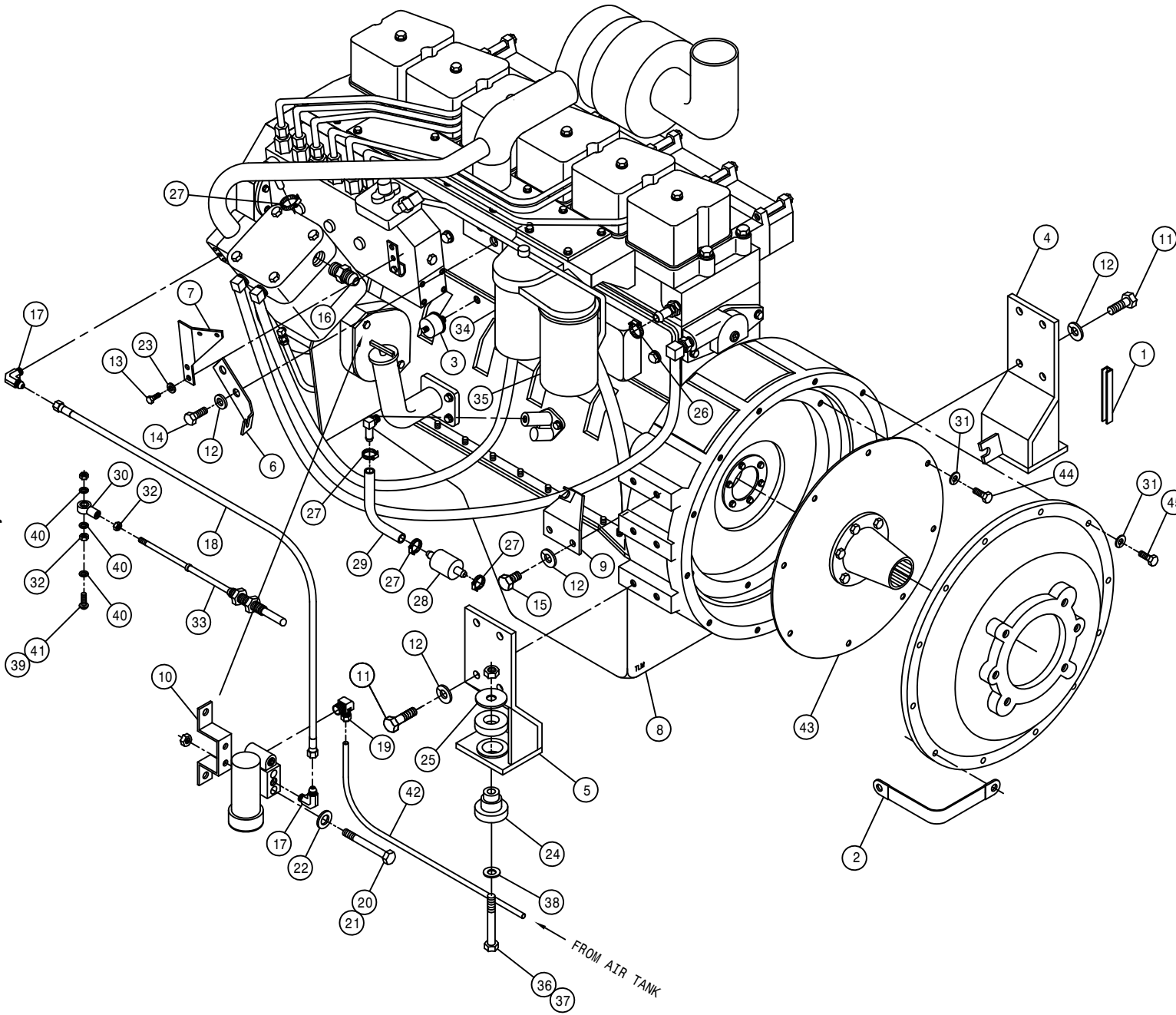

ENGINE ASSEMBLY

DET. QTY PART NO. DESCRIPTION

1	1	193012	QUICKEDGE TRIM .135 TO .250
2	1	291197	CIRCUIT BREAKER,30AMP,INLINEM
3	1	291556	CIRCUIT BREAKER,50AMP,INLINEM
4	1	314832	RADIATOR HOSE 1.75 X 19
5	1	314836	TEMP SENDR 280D 1/2NPT FOR GA
6	1	316180	FAN, 22" 6 BLADE 30DEG 2.25PIT
7	1	316199	22IN FAN SPACER CUMM 92
8	1	316250	RH FRT ENG MT WLD, CUMM 94
9	1	316312	CUMM ENG,6B5.9A 152@2500 CMPSR
10	1	316313	LH FRT ENG MT WLD, 284 CUMM 98
11	1	316339	BREAKER MTG PLT, 2100 98
12	1	316340	BREAKER COVER, 2100 98
13	4	470175	10-32 HEX FLANGE LOCK NUT
14	2	470216	10-32 X 3/4 FLANGE HEX BOLT
15	6	473775	12MM-1.75 X 30MM HEX BOLT
16	2	473782	12MM-1.75 X 18MM HEX BOLT
17	8	473784	12MM LOCK WASHER
18	4	473804	8MM LOCK WASHER
19	4	473822	8MM-1.25 X 70MM HEX BOLT
20	2	520067	HOSE CLAMP NO 28 STAINLESS
21	1	618573	5/8 HOSE BARB-90-1/2MNPT
22	4	903812	6-32 X 1/2 SLT RD HD MACH SCR
23	8	910022	6-32 HEX NUT
24	4	910027	10-32 HEX NUT
25	2	311053	RUBBER MOUNT SET,SSB26-1000-1
26	1	314886	RADIATOR HOSE 2 1/4 20717
27	1	470118	1/4UNC X 3/4 FLANGE HEX BOLT
28	1	470121	1/4UNC HEX FLANGE LOCK NUT
29	4	900265	1/2UNC X 1 1/2 HEX BOLT
30	1	520055	HOSE CLAMP NO 12 STAINLESS
31	2	900271	1/2UNC X 3 1/4 HEX BOLT
32	6	914008	1/2UNC HEX STOVER NUT
33	6	920004	1/2 SAE FLAT WASHER
34	1	520126	CUSH HOSE CLAMP 2IN X 5/8W
35	2	520099	HOSE CLAMP NO 40 STAINLESS
36	1	316206	POLY V BELT CUMMINS DIESEL 92
37	1	316207	LUBE FILTER CUMMINS DIESEL 92
38	1	341968	TIE PLT 250/280 CUMM 92

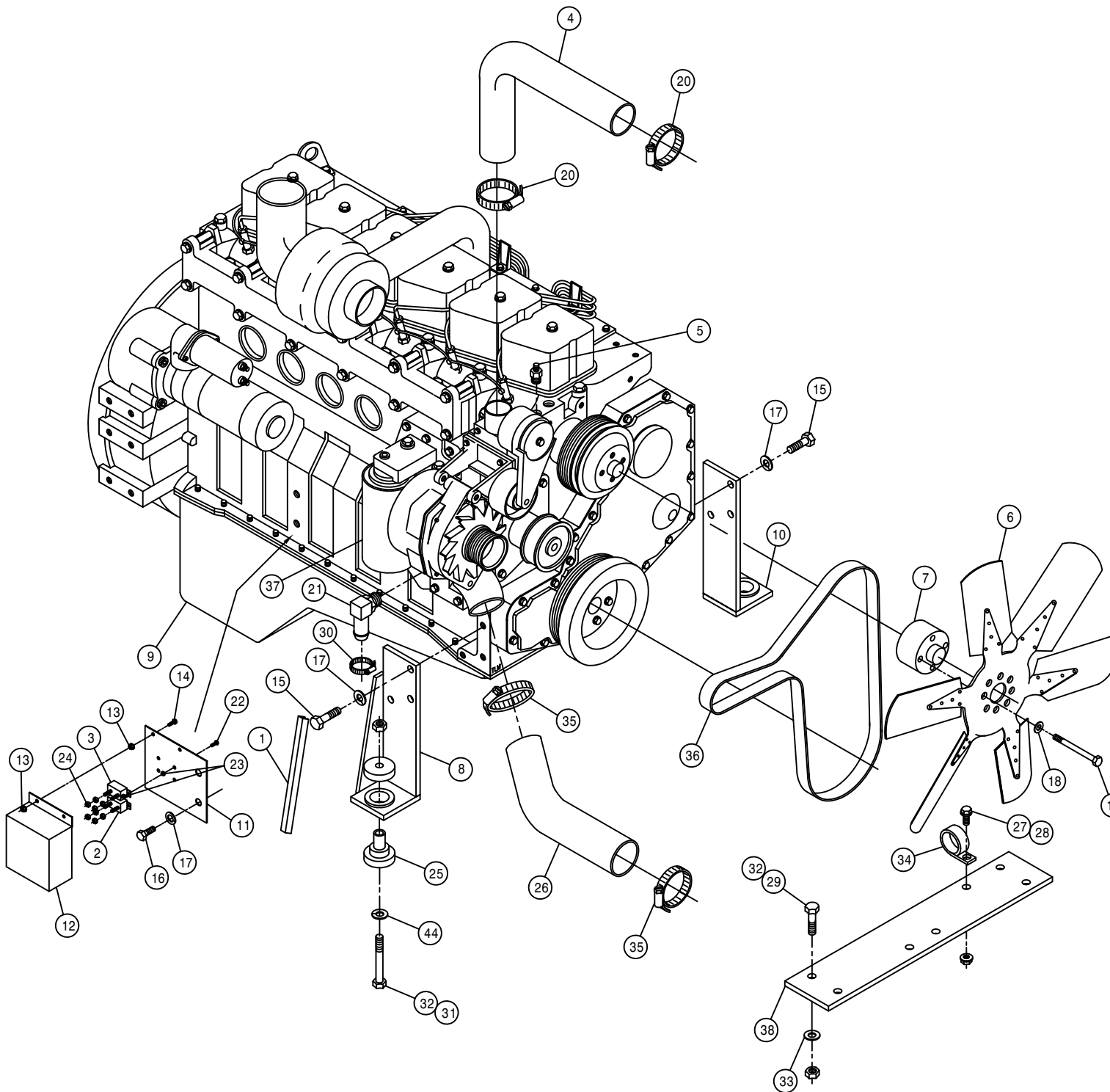

5

SUNDSTRAND PUMP ASSEMBLY

DET.	QTY	PART NO.	DESCRIPTION
1	1	316319	PUMP CTRL LEVER EXT,284 CUMM98
2	1	505098	SIDE OUTLET EL 90DEG 1.00NPT
3	1	505101	BLK PIPE TEE 1.00NPT
4	2	505105	1MNPT HEX PIPE NIPPLE STL
5	1	505200	BLK PIPE ST EL 90DEG 1.00NPT
6	1	505213	RED BUSH 1 X 3/4 BLK MAL
7	2	520137	.75 T-BOLT HOSE CLAMP
8	1	601383	HOSE, 3/4 X 8 1FBR-1SPI
9	1	606941	TANDEM PUMP, 606929 & 606932
10	1	606929	SUND GEAR PUMP .66CI, SPLINED
11	1	606932	SUND GEAR PUMP,1.60CI,SPLINED
12	1	606954	SUND 130CC PUMP,B-MT 98
13	1	610300	3/4MJIC-3/4MNPT ADPTR
14	1	611128	7/8MJIC-90-7/8MOR LBO
15	1	618075	3/4 HOSE BARB-1 1/16MOR
16	1	618090	1 5/16MOR-1FNPT ADPTR
17	3	618126	9/16MJIC-9/16MOR ADPTR
18	2	618327	3/4MJIC-7/8MOR ADPTR
19	1	618328	7/8FJIC CAP NUT
20	1	618333	7/8FJIC SW RUN TEE-7/8MJIC
21	2	618459	1 1/4FLANGE-90-1 5/8MJIC
22	2	618461	1 1/4 SPLIT FLANGE KIT
23	2	870222	NEO ORING 1 1/2 X 1 3/4
24	1	618486	9/16FJIC SW RUN TEE-9/16MJIC
25	3	618514	9/16FJ SW BRANCH TEE-9/16MJ
26	3	618531	9/16FJIC CAP NUT
27	1	618535	7/8MJIC-90-1 1/16MOR LBO
28	2	618547	1 5/8FJIC-1 5/16MJIC ADPTR
29	1	618564	1IN HOSE BARB-90-1 5/16MOR
30	2	618609	3/4MJIC-90-3/4FJIC SWIV LBO
31	1	618618	9/16MJIC-90-9/16FJIC SWIV LBO
32	4	618619	1 5/16FJ SW RUN TEE-15/16MJ
33	1	618626	1 1/4 HOSE BARB-45-1 5/8MOR
34	2	618630	1 5/16MJ-45-1 5/16FJ SWIV LBO
35	2	618640	1 5/16MJ-90-1 5/16FJ SWIV LBO
36	1	714560	1NPT X 1 HOSE BARB
37	1	716000	3/4 HOSE BARB-90-1MNPT
38	2	900003	1/4UNC X 1" HEX BOLT
39	4	900401	3/4UNC X 1 1/2 HEX BOLT
40	1	903893	10-32 X 1" SLT RD HD MACH SCR
41	2	914000	1/4UNC HEX STOVER NUT
42	2	910027	10-32 HEX NUT
43	3	920510	#10 LOCK WASHER
44	4	920006	3/4 SAE FLAT WASHER
45	1	785062	CTRL CABLE 10-32 4IN X 120 LG
46	1	473921	BALL JOINT NO 10-32 THD
47	1	914027	10-32 HEX STOVER NUT
48	1	520132	1.62/1.87 T-BOLT HOSE CLAMP
49	2	520138	1.00 T-BOLT HOSE CLAMP
50	1	606870	O-RING FOR 606865 SUND B-MT
51	1	606924	O-RING FOR SUND A-MT
52	2	618541	1 5/16FJIC-1 1/16MJIC ADPTR

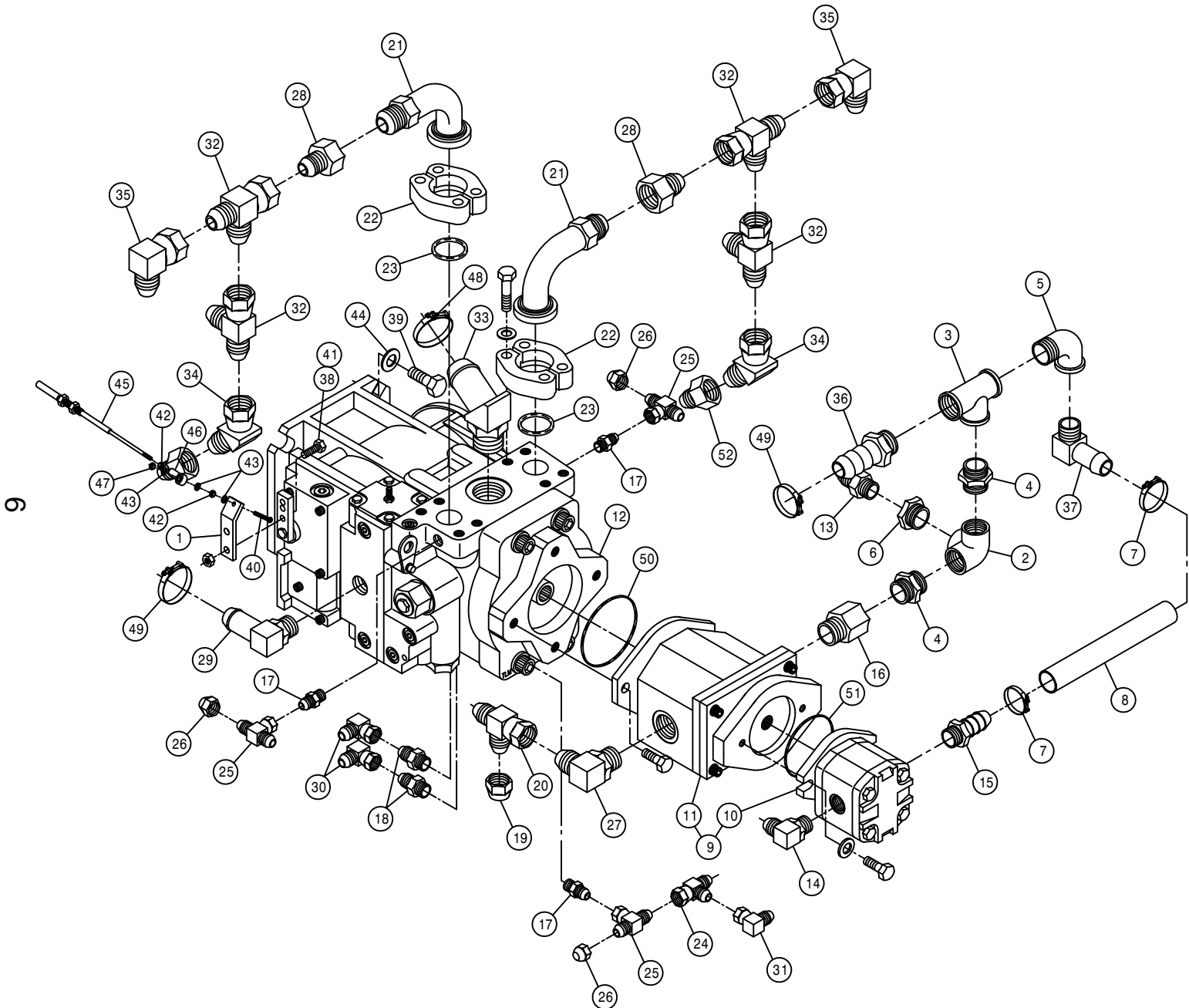

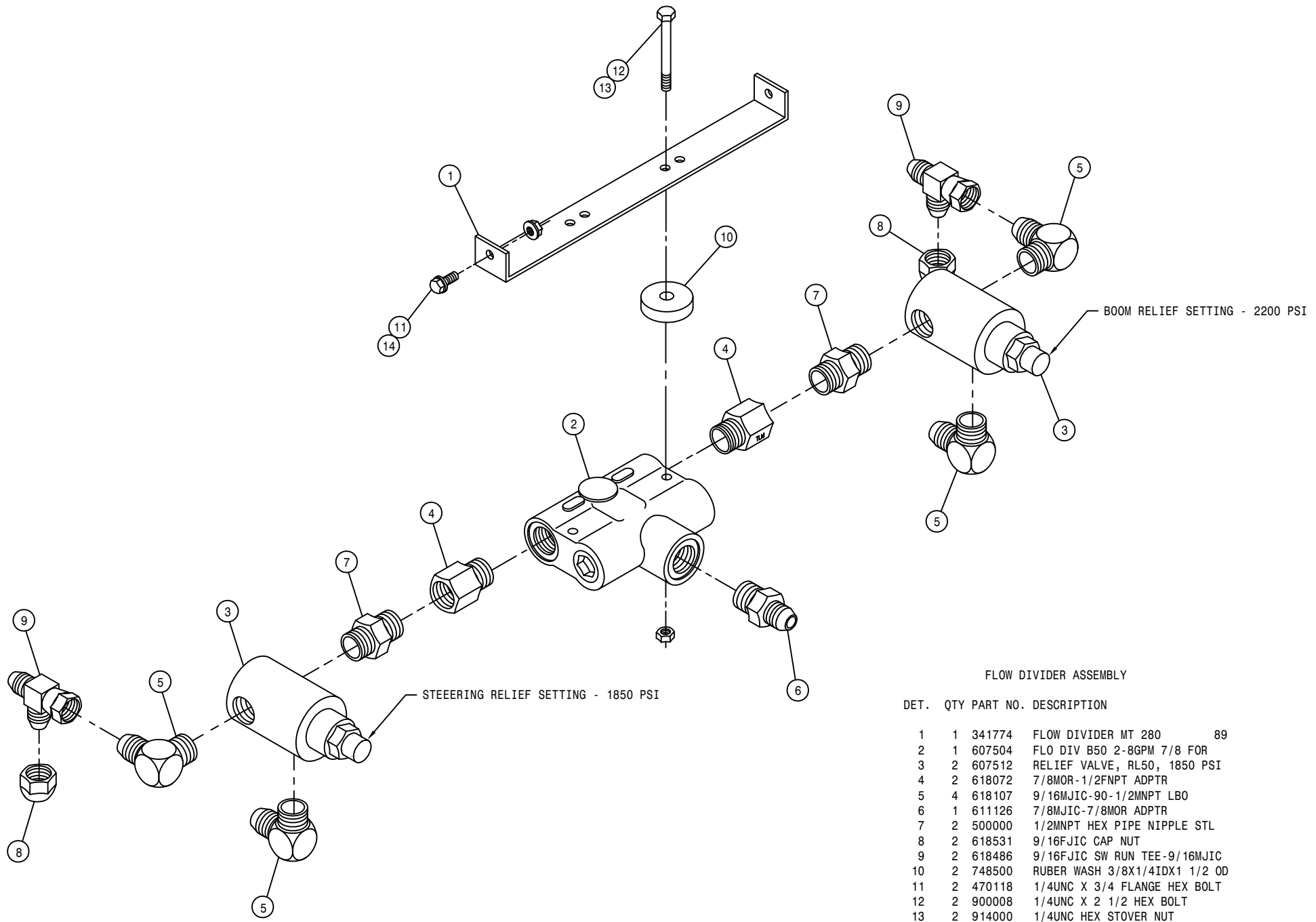

FLOW DIVIDER ASSEMBLY

DET.	QTY	PART NO.	DESCRIPTION	
	1	341774	FLOW DIVIDER MT 280	89
	1	607504	FLO DIV B50 2-8GPM 7/8 FOR	
	2	607512	RELIEF VALVE, RL50, 1850 PSI	
	4	618072	7/8MOR-1/2FNPT ADPTR	
	5	618107	9/16MJIC-90-1/2MNPT LBO	
	6	611126	7/8MJIC-7/8MOR ADPTR	
	7	500000	1/2MNPT HEX PIPE NIPPLE STL	
	8	618531	9/16FJIC CAP NUT	
	9	618486	9/16FJIC SW RUN TEE-9/16MJIC	
	10	748500	RUBER WASH 3/8X1/4IDX1 1/2 OD	
	11	470118	1/4UNC X 3/4 FLANGE HEX BOLT	
	12	900008	1/4UNC X 2 1/2 HEX BOLT	
	13	914000	1/4UNC HEX STOVER NUT	
	14	470121	1/4UNC HEX FLANGE LOCK NUT	

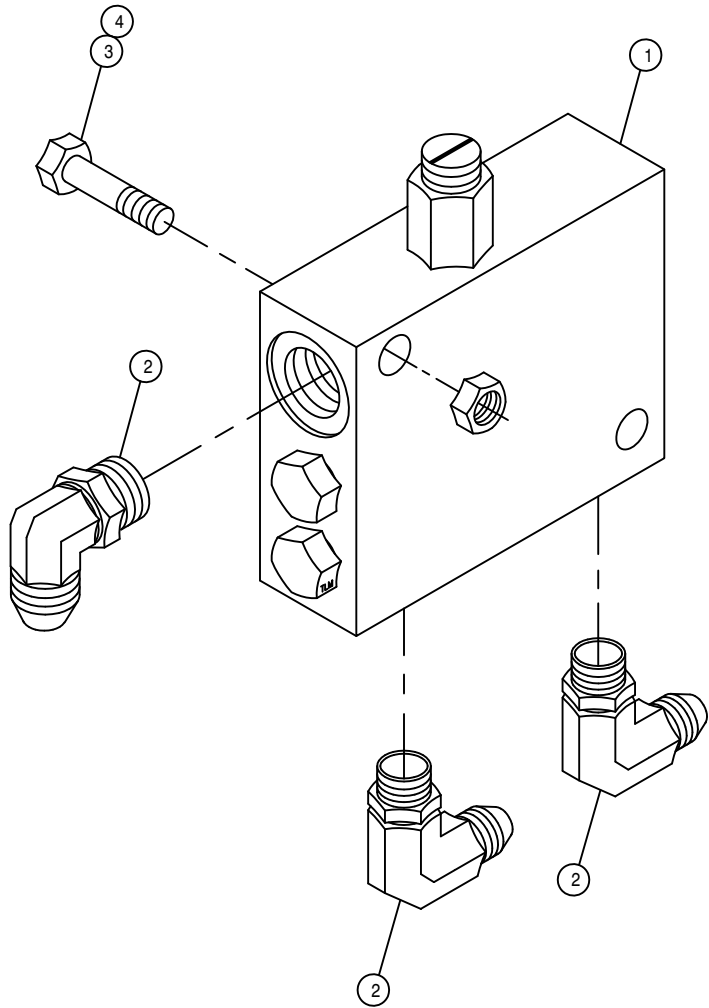

LOOP FLUSHING VALVE ASSEMBLY

DET. QTY PART NO. DESCRIPTION

1	1	610580	REMOTE FLUSHING VALVE, SUND
2	3	618119	9/16MJCIC-90-9/16MOR LBO
3	2	900133	3/8UNC X 2" HEX BOLT
4	2	914004	3/8UNC HEX STOVER NUT

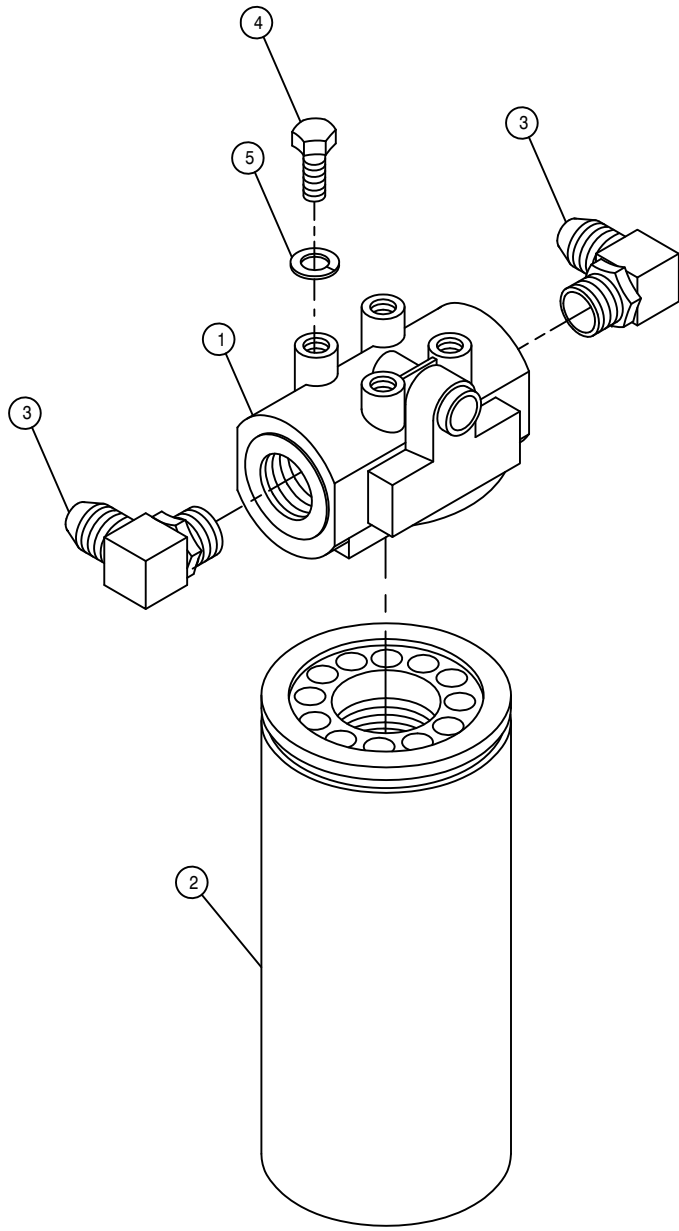

HI-PRESS FILTER ASSEMBLY

DET. QTY PART NO. DESCRIPTION

1	1	605608	HYD FILTER HEAD, DONALDSON
2	1	605609	HYD FILTER ELEMENT, DONALDSON
3	2	618474	3/4MJIC-90-1 1/16MOR LBO
4	4	900128	3/8UNC X 3/4 HEX BOLT
5	4	920502	3/8 LOCK WASHER

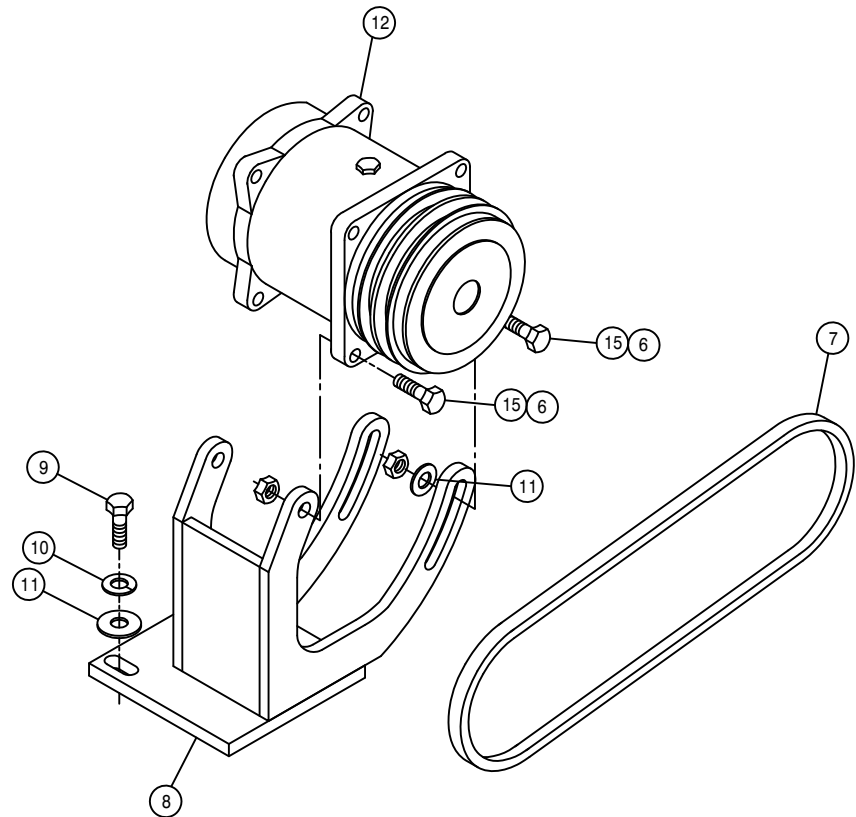
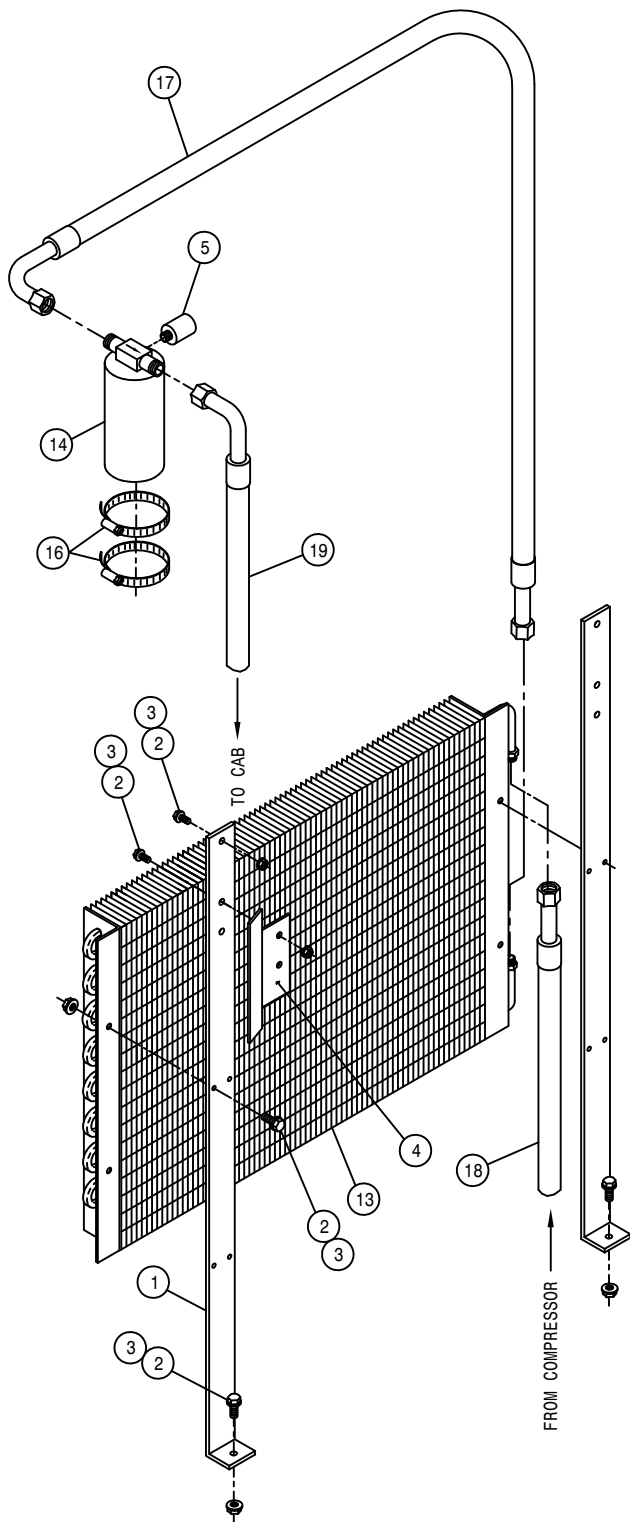

A/C COMPRESSOR PUMP ASSEMBLY

DET. QTY PART NO. DESCRIPTION

1	2	315036	CONDENSER MTG BRKT	99
2	10	470118	1/4UNC X 3/4 FLANGE HEX BOLT	
3	10	470121	1/4UNC HEX FLANGE LOCK NUT	
4	1	315038	A/C DRIER MT,204-254-284	99
5	1	657422	A/C BINARY SWITCH	MCC
6	4	914004	3/8UNC HEX STOVER NUT	
7	1	147050	9455XL BELT, GATES	
8	1	316314	A/C COMPRSR MT WLD, 284	98
9	3	473792	10MM-1.50 X 30MM HEX BOLT	
10	3	473798	10MM LOCK WASHER	
11	5	483043	3/8 REGULAR FLAT WASHER	
12	1	657403	A/C COMPRESSOR, SELTEC TM15/12	
13	1	657423	A/C CONDENSER COIL	MCC
14	1	657421	A/C RECEIVER/DRIER	MCC
15	4	900131	3/8UNC X 1 1/2 HEX BOLT	
16	2	520052	HOSE CLAMP NO 52 STAINLESS	
17	1	657429	A/C HOSE ASSY, 5/16 X 44	MCC
18	1	657430	A/C HOSE ASSY, 13/32 X 80	MCC
19	1	657431	A/C HOSE ASSY, 5/16 X 173	MCC

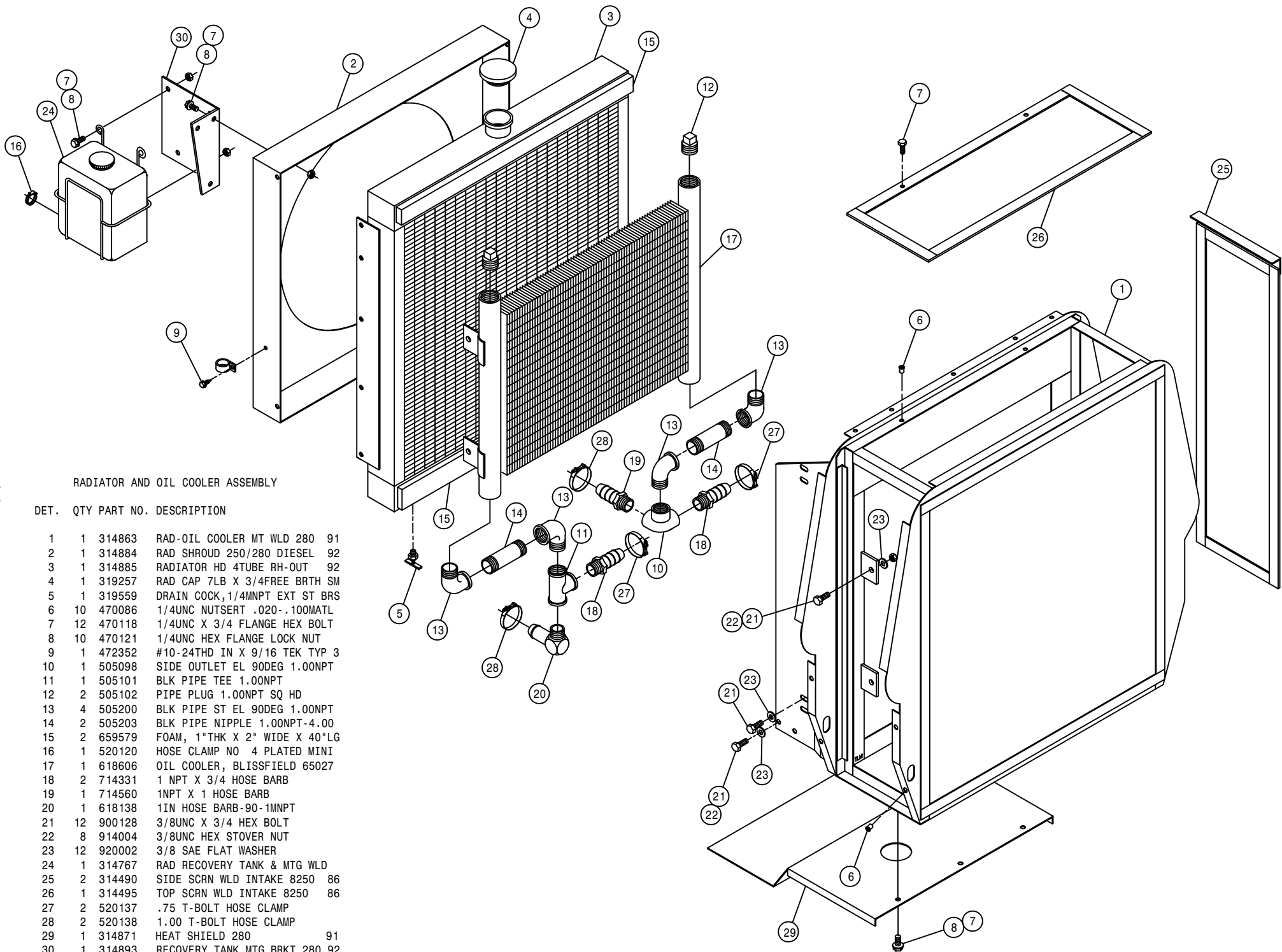

RADIATOR AND OIL COOLER ASSEMBLY

DET. QTY PART NO. DESCRIPTION

1	1	314863	RAD-OIL COOLER MT WLD 280	91
2	1	314884	RAD SHROUD 250/280 DIESEL	92
3	1	314885	RADIATOR HD 4TUBE RH-OUT	92
4	1	319257	RAD CAP 7LB X 3/4FREE BRTH SM	
5	1	319559	DRAIN COCK, 1/4MNPT EXT ST BRS	
6	10	470086	1/4UNC NUTSERT .020-.100MATL	
7	12	470118	1/4UNC X 3/4 FLANGE HEX BOLT	
8	10	470121	1/4UNC HEX FLANGE LOCK NUT	
9	1	472352	#10-24THD IN X 9/16 TEK TYP 3	
10	1	505098	SIDE OUTLET EL 90DEG 1.00NPT	
11	1	505101	BLK PIPE TEE 1.00NPT	
12	2	505102	PIPE PLUG 1.00NPT SQ HD	
13	4	505200	BLK PIPE ST EL 90DEG 1.00NPT	
14	2	505203	BLK PIPE NIPPLE 1.00NPT-4.00	
15	2	659579	FOAM, 1"THK X 2" WIDE X 40"LG	
16	1	520120	HOSE CLAMP NO 4 PLATED MINI	
17	1	618606	OIL COOLER, BLISSFIELD 65027	
18	2	714331	1 NPT X 3/4 HOSE BARB	
19	1	714560	1NPT X 1 HOSE BARB	
20	1	618138	1IN HOSE BARB-90-1MNPT	
21	12	900128	3/8UNC X 3/4 HEX BOLT	
22	8	914004	3/8UNC HEX STOVER NUT	
23	12	920002	3/8 SAE FLAT WASHER	
24	1	314767	RAD RECOVERY TANK & MTG WLD	
25	2	314490	SIDE SCR N WLD INTAKE 8250	86
26	1	314495	TOP SCR N WLD INTAKE 8250	86
27	2	520137	.75 T-BOLT HOSE CLAMP	
28	2	520138	1.00 T-BOLT HOSE CLAMP	
29	1	314871	HEAT SHIELD 280	91
30	1	314893	RECOVERY TANK MTG BRKT 280	92

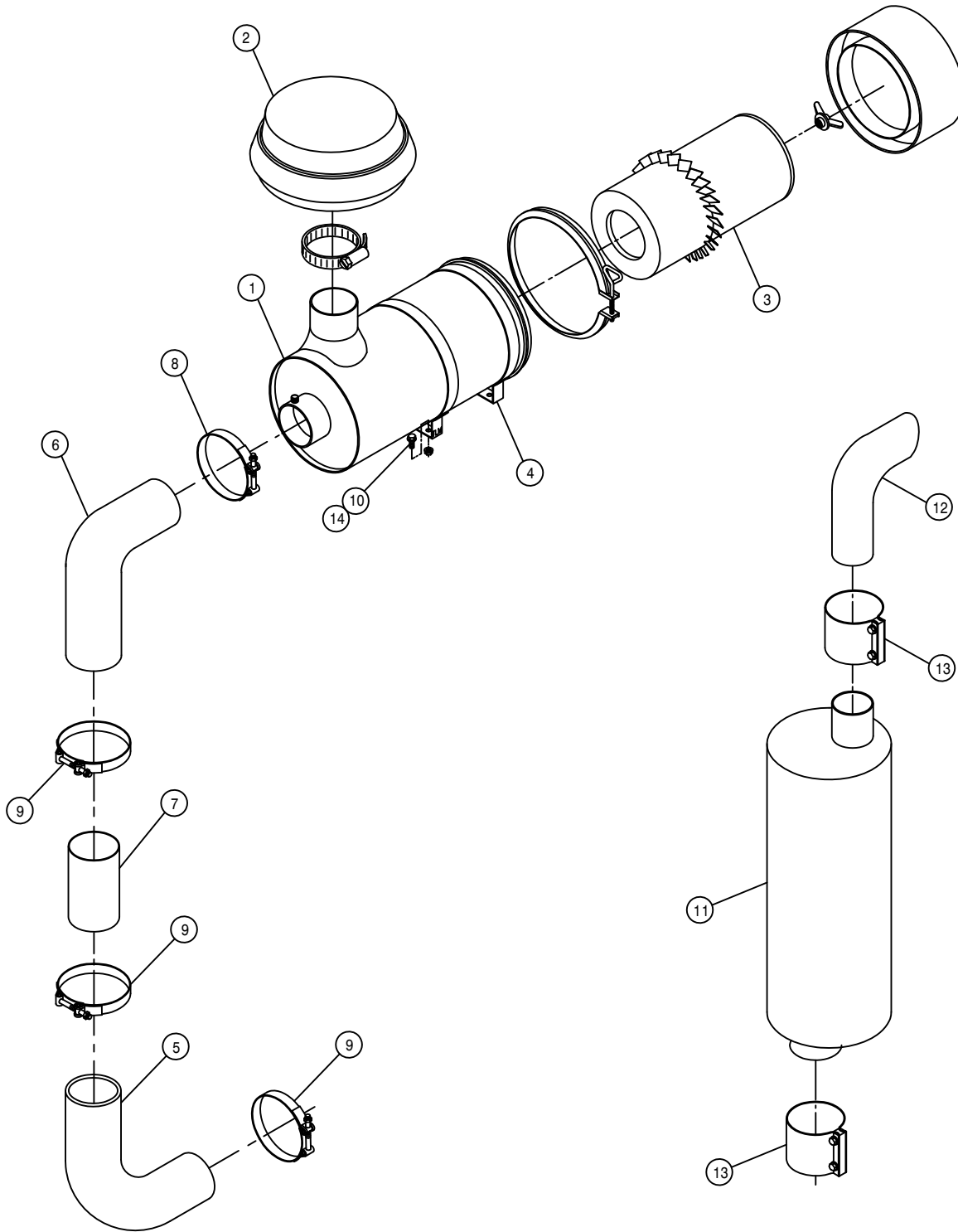

AIR CLEANER AND EXHAUST PIPE

DET. QTY PART NO. DESCRIPTION

1	1	314970	AIR CLEANER, 510 CFM
2	1	314971	AIR CLEANER HOOD FOR 314970
3	1	314973	AIR CLEANER ELEMENT FOR314970
4	2	314972	AIR CLEANER MT BAND FOR314970
5	1	316309	4" 90DEG ELBOW, RUBBER
6	1	316297	5" -4" 90DEG REDU ELBOW,RUBBER
7	1	316298	4" X 11.50" AIR INTAKE TUBE,97
8	1	520136	5.00 T-BOLT HOSE CLAMP
9	3	520134	4.00 T-BOLT HOSE CLAMP
10	4	470113	5/16UNC HEX FLANGE LOCK NUT
11	1	316299	MUFFLER, 3" DONALDSON 97
12	1	316300	3" EXHAUST STACK 97
13	2	470243	3" STRAP BAND EXHAUST CLAMP
14	4	470233	5/16UNC X 3/4 FLANGE HEX BOLT

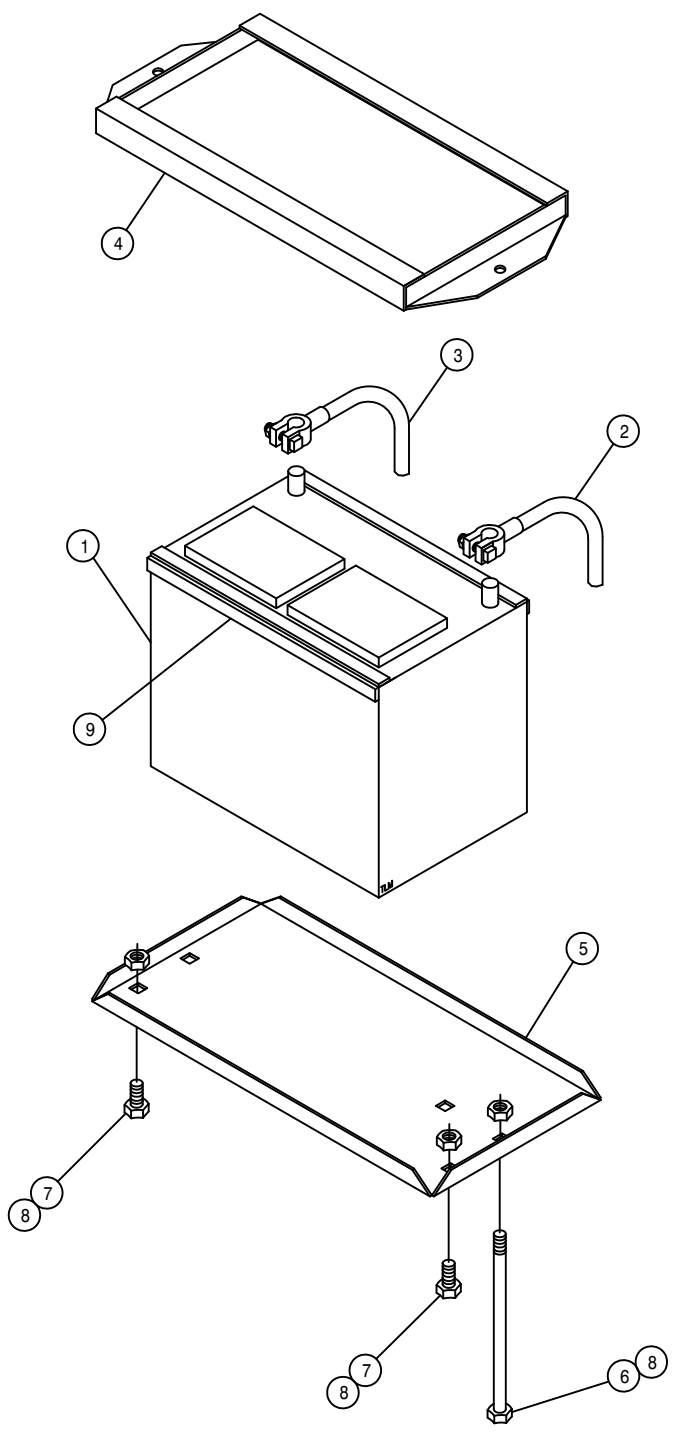

BATTERY BOX ASSEMBLY

DET.	QTY	PART NO.	DESCRIPTION
1	1	291122	BATTERY, 950 C.C.A. 185 RES
2	1	291128	BATTERY CABLE 48 IN
3	1	291530	BATTERY GROUND CABLE, 23"
4	1	341322	BATTERY HOLD DOWN WLD 1981
5	1	361149	BATTERY BOX 8300-8400 1981
6	2	901150	3/8UNC X 9" CARR BOLT
7	2	900129	3/8UNC X 1" HEX BOLT
8	4	914004	3/8UNC HEX STOVER NUT
9	4	193022	STICKERTITE 1/4 X 3/4

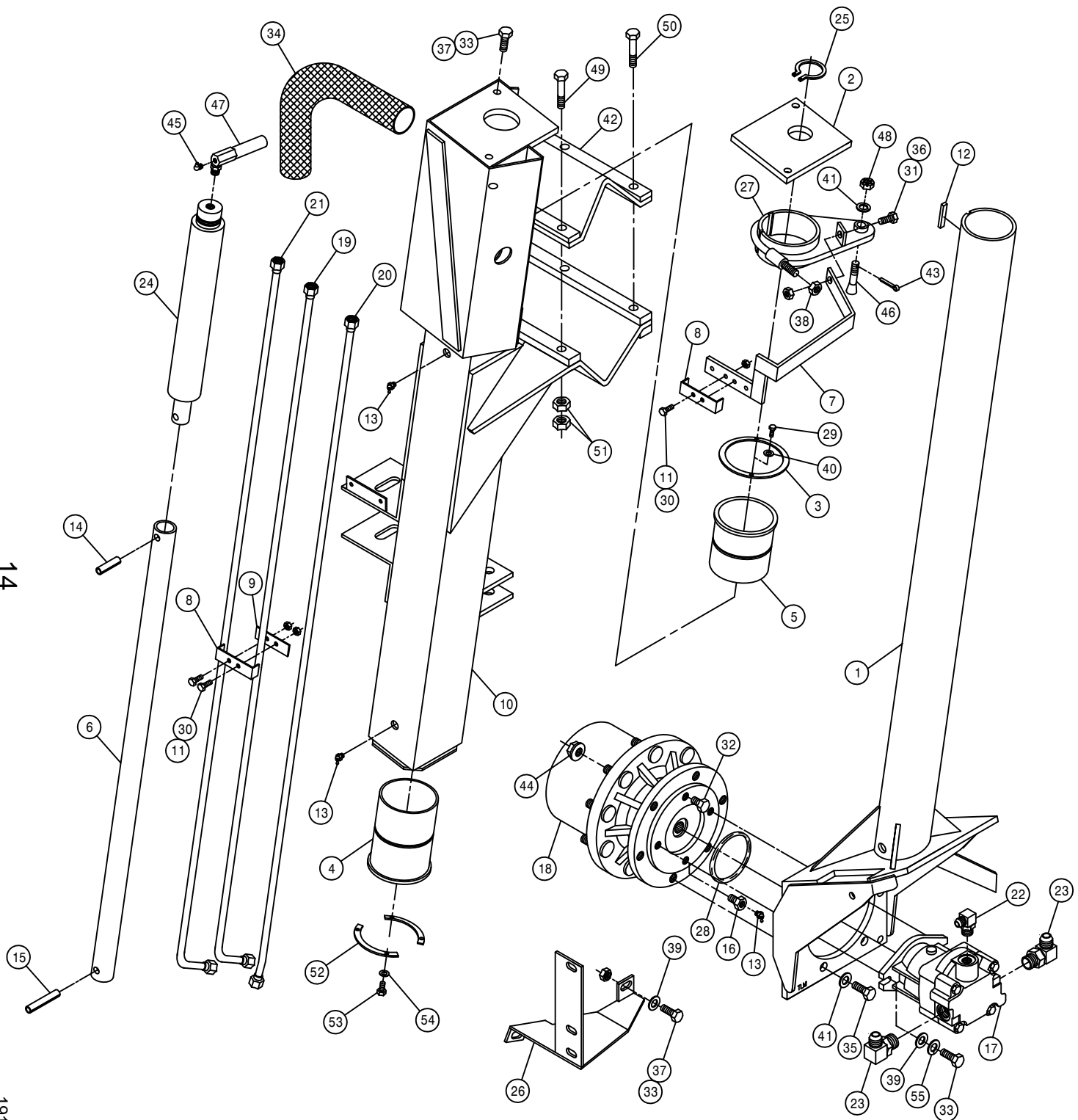

RIGHT FRONT LEG ASSEMBLY

DET.	QTY	PART NO.	DESCRIPTION	
1	1	358535	RH FRT INNER LEG WLD 280	89
2	1	358562	LEG CYL MTG PLATE 280	89
3	1	358563	FRT LEG BRG KPR 280	89
4	1	358564	FRT LEG LWR NYL SLEEVE 280	89
5	1	358565	FRT LEG UPR NYL SLEEVE 280	89
6	1	358566	LEG CYL SHAFT EXTENSION280	89
7	1	358707	RH FRT LEG TUBE BRKT WLD280TA	
8	2	358739	FRT LEG HYD TUBE CLMP, 284	94
9	1	358740	FRT LEG HYD TUBE KPR, 284	94
10	1	358947	RH FRT OUTER LEG WLD, 284	99
11	4	470121	1/4UNC HEX FLANGE LOCK NUT	
12	1	470185	KEY .25 X .375 X 2.00 LG	
13	3	471023	GREASE ZERK 1/4-28 X 45	
14	1	473903	SPIRAL PIN 1/2 X 2	640
15	1	473904	SPIRAL PIN 1/2 X 3	640
16	1	610556	1/2UNC X 1/2 ZERK BOLT T-HUB	
17	1	610571	SUND M35-3002 WHL MTR	
18	1	610683	TORQ HUB, 15:1 B-MT MW3BA	
19	1	615656	FRT LEG CNTR HYD TUBE ASSY284	
20	1	615702	FRT LEG INR HYD TUBE ASSY28496	
21	1	615703	RH FRTLEG OUTHYDTUBE ASY28496	
22	1	618183	3/4MJIC-90-7/8MOR LBO	
23	2	618248	1 1/16MJIC-90-1 1/16MOR LBO	
24	1	620570	HYD CYL LEG LEVEL 2.00 X 12	
25	1	629515	SNAP RING 1 3/4 EXTRN HDUTY	
26	1	662157	RH FRT MTG WLD FOR CROP GUIDE	
27	1	749290	RH STRG ARM WLD,280 TREAD ADJ	
28	1	870045	O-RING 4 1/8 OD X 4 ID	
29	2	900000	1/4UNC X 1/2 HEX BOLT	
30	4	900005	1/4UNC X 1 1/2 HEX BOLT	
31	1	900129	3/8UNC X 1" HEX BOLT	
32	1	900260	1/2UNC X 1/2 H BOLT GR2 UNPLT	
33	7	900265	1/2UNC X 1 1/2 HEX BOLT	
34	1	342335	NYL HOSE SLEEVE,2.64ID X 36.00	
35	6	900333	5/8UNC X 1 1/2 HEX BOLT	
36	1	914004	3/8UNC HEX STOVER NUT	
37	5	914008	1/2UNC HEX STOVER NUT	
38	1	914010	5/8UNC HEX STOVER NUT	
39	5	920004	1/2 SAE FLAT WASHER	
40	2	920500	1/4 LOCK WASHER	
41	7	920505	5/8 LOCK WASHER	
42	1	358759	LEG MT V-PLT WLD, 284T	94
43	1	470035	COTTER PIN 5/32 X 1 1/2	
44	9	470140	5/8UNF HEX SMTH FLANGE NUT PLT	
45	1	471027	GREASE ZERK 1/8NPT 90DEG LP	
46	1	749293	STRG ARM BOLT, TAPERED	
47	1	615614	FRT LEG CYL JUMPER HOSE280	89
48	1	822040	5/8-18UNF SLOTTED HEX NUT	
49	3	900836	5/8UNF X 3 1/4 HEX BOLT GR8	
50	3	900837	5/8UNF X 3 1/2 HEX BOLT GR8	
51	12	914811	5/8UNF HEX NUT GR8	
52	2	358927	LWR BRG KPR, LEG	98
53	4	900064	5/16UNC X 3/4 HEX BOLT	
54	4	920501	5/16 LOCK WASHER	
55	2	920504	1/2 LOCK WASHER	

LEFT FRONT LEG ASSEMBLY

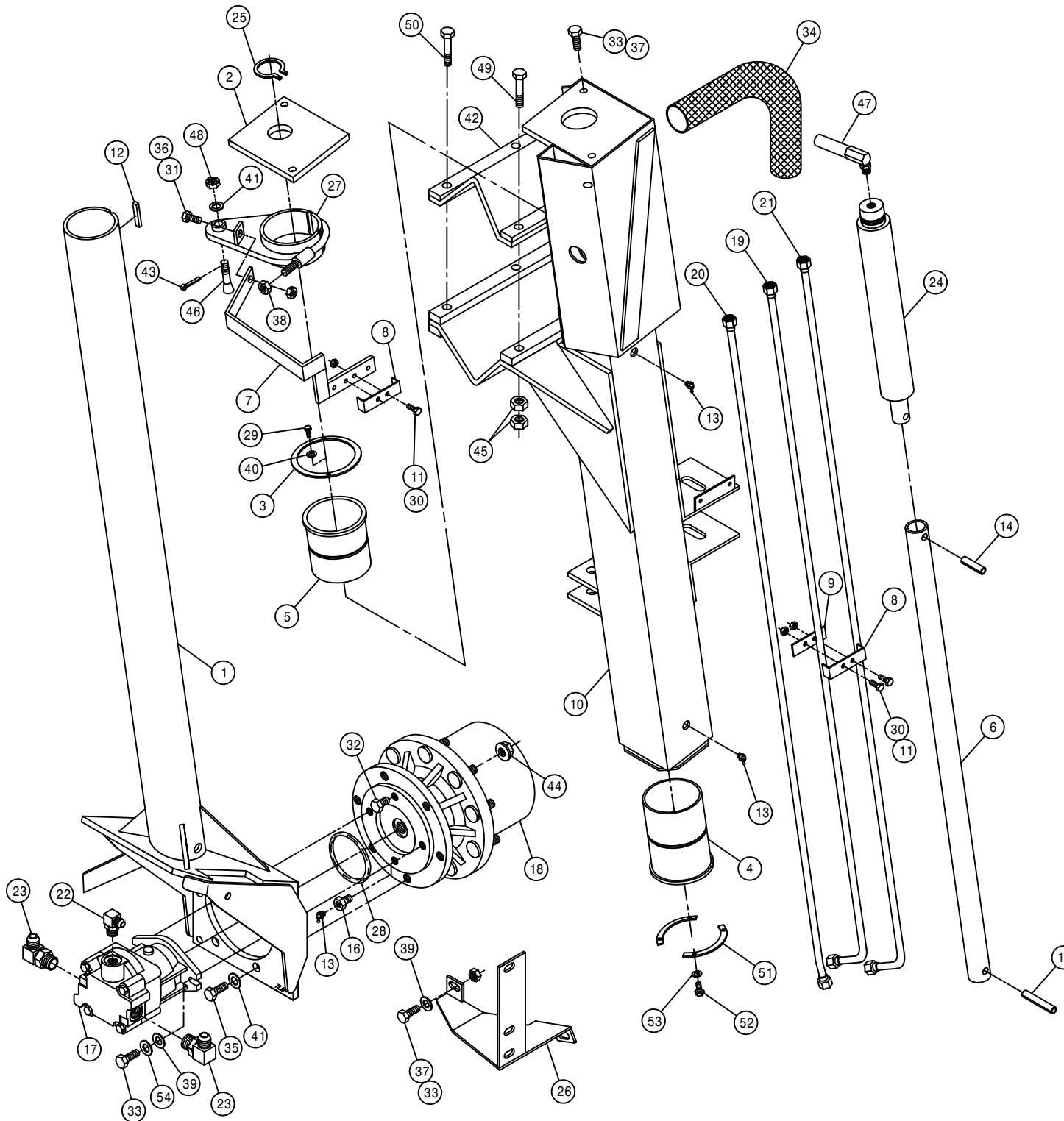

DET.	QTY	PART NO.	DESCRIPTION	
1	1	358536	LH FRT INNER LEG WLD 280	89
2	1	358562	LEG CYL MTG PLATE 280	89
3	1	358563	FRT LEG BRG KPR 280	89
4	1	358564	FRT LEG LWR NYL SLEEVE 280	89
5	1	358565	FRT LEG UPR NYL SLEEVE 280	89
6	1	358566	LEG CYL SHAFT EXTENSION280	89
7	1	358708	LH FRT LEG TUBE BRKT WLD280TA	
8	2	358739	FRT LEG HYD TUBE CLMP, 284	94
9	1	358740	FRT LEG HYD TUBE KPR, 284	94
10	1	358948	LH FRT OUTER LEG WLD, 284	99
11	4	470121	1/4UNC HEX FLANGE LOCK NUT	
12	1	470185	KEY .25 X .375 X 2.00 LG	
13	3	471023	GREASE ZERK 1/4-28 X 45	
14	1	473903	SPIRAL PIN 1/2 X 2	640
15	1	473904	SPIRAL PIN 1/2 X 3	640
16	1	610556	1/2UNC X 1/2 ZERK BOLT T-HUB	
17	1	610571	SUND M35-3002 WHL MTR	
18	1	610683	TORQ HUB, 15:1 B-MT MW3BA	
19	1	615656	FRT LEG CNTR HYD TUBE ASSY284	
20	1	615702	FRT LEG INR HYD TUBE ASSY28496	
21	1	615704	LH FRTLEG OUTHYDTUBE ASY28496	
22	1	618183	3/4MJIC-90-7/8MOR LBO	
23	2	618248	1 1/16MJIC-90-1 1/16MOR LBO	
24	1	620570	HYD CYL LEG LEVEL 2.00 X 12	
25	1	629515	SNAP RING 1 3/4 EXTRN HDUTY	
26	1	662156	LH FRT MTG WLD FOR CROP GUIDE	
27	1	749291	LH STRG ARM WLD,280 TREAD ADJ	
28	1	870045	O-RING 4 1/8 OD X 4 ID	
29	2	900000	1/4UNC X 1/2 HEX BOLT	
30	4	900005	1/4UNC X 1 1/2 HEX BOLT	
31	1	900129	3/8UNC X 1" HEX BOLT	
32	1	900260	1/2UNC X 1/2 H BOLT GR2 UNPLT	
33	7	900265	1/2UNC X 1 1/2 HEX BOLT	
34	1	342335	NYL HOSE SLEEVE,2.64ID X 36.00	
35	6	900333	5/8UNC X 1 1/2 HEX BOLT	
36	1	914004	3/8UNC HEX STOVER NUT	
37	5	914008	1/2UNC HEX STOVER NUT	
38	1	914010	5/8UNC HEX STOVER NUT	
39	5	920004	1/2 SAE FLAT WASHER	
40	2	920500	1/4 LOCK WASHER	
41	7	920505	5/8 LOCK WASHER	
42	1	358759	LEG MT V-PLT WLD, 284T	94
43	1	470035	COTTER PIN 5/32 X 1 1/2	
44	9	470140	5/8UNF HEX SMTH FLANGE NUT PLT	
45	12	914811	5/8UNF HEX NUT GR8	
46	1	749293	STRG ARM BOLT, TAPERED	
47	1	615614	FRT LEG CYL JUMPER HOSE280	89
48	1	822040	5/8-18UNF SLOTTED HEX NUT	
49	3	900836	5/8UNF X 3 1/4 HEX BOLT GR8	
50	3	900837	5/8UNF X 3 1/2 HEX BOLT GR8	
51	2	358927	LWR BRG KPR, LEG	98
52	4	900064	5/16UNC X 3/4 HEX BOLT	
53	4	920501	5/16 LOCK WASHER	
54	2	920504	1/2 LOCK WASHER	

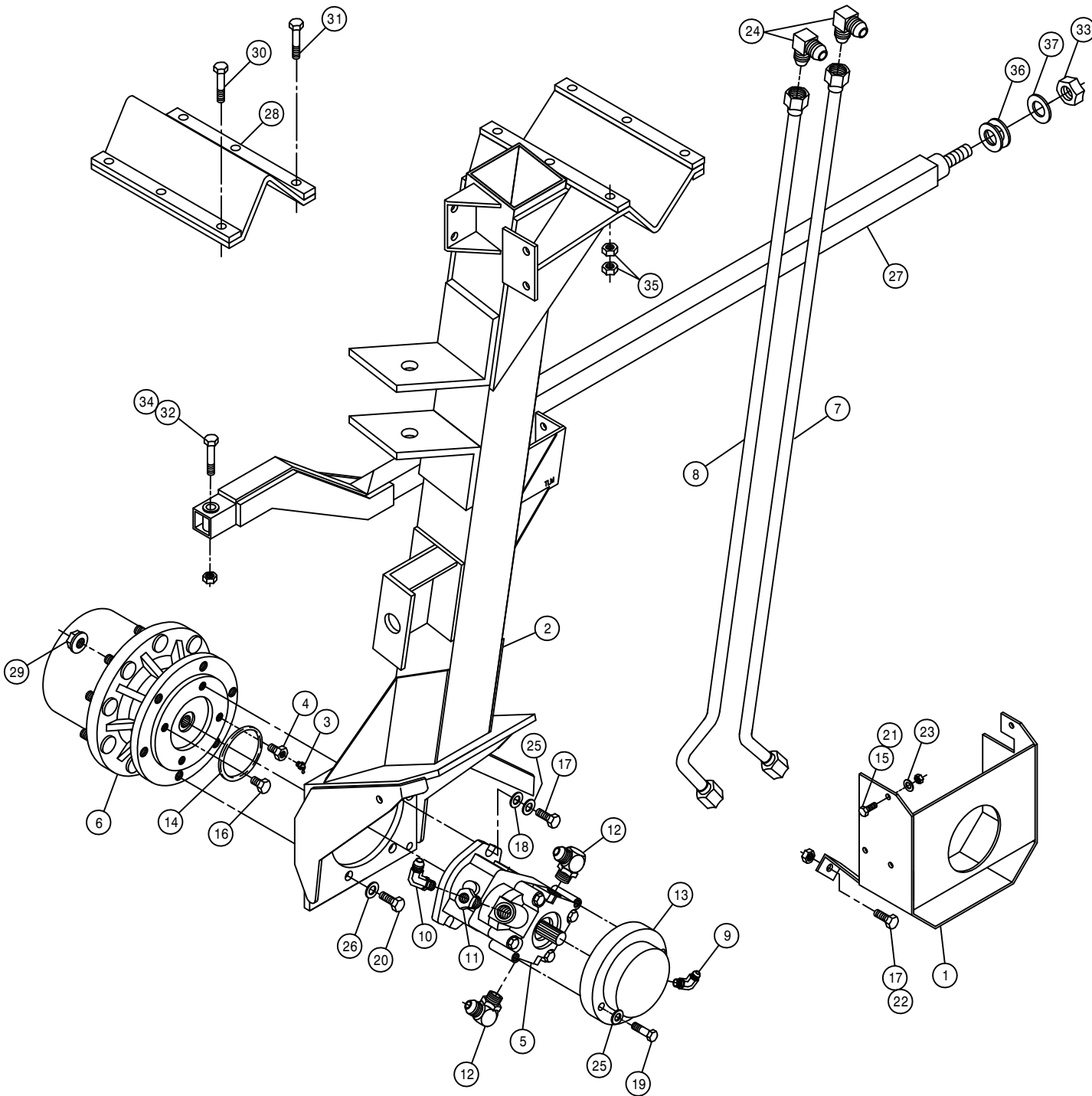

RIGHT REAR LEG ASSEMBLY

DET.	QTY	PART NO.	DESCRIPTION	
1	1	358823	RH REAR WHL MTR SHLD WLD	97
2	1	358827	RH REAR LEG WLD, 284	97
3	1	471023	GREASE ZERK 1/4-28 X 45	
4	1	610556	1/2UNC X 1/2 ZERK BOLT T-HUB	
5	1	610557	SUND M35-3102 WHL MTR W/SHFT	
6	1	610692	TORQ HUB, 30:1 B-MT MW3BA	
7	1	615705	REAR LEG HYD TUBE ASSY 284	97
8	1	615706	RH REAR LEG HYDTUBE ASSY284	97
9	1	618114	9/16MJIC-90-7/16MOR LBO	
10	1	618119	9/16MJIC-90-9/16MOR LBO	
11	1	618172	7/8MOR-9/16FOR ADPTR	
12	2	618576	1 5/16MJIC-90-1 1/16MOR LBO	
13	1	828092	MICO HYD BRAKE	
14	1	870045	O-RING 4 1/8 OD X 4 ID	
15	2	900130	3/8UNC X 1 1/4 HEX BOLT	
16	1	900260	1/2UNC X 1/2 H BOLT GR2 UNPLT	
17	4	900265	1/2UNC X 1 1/2 HEX BOLT	
18	2	920004	1/2 SAE FLAT WASHER	
19	2	900268	1/2UNC X 2 1/2 HEX BOLT	
20	6	900333	5/8UNC X 1 1/2 HEX BOLT	
21	2	914004	3/8UNC HEX STOVER NUT	
22	2	914008	1/2UNC HEX STOVER NUT	
23	2	920002	3/8 SAE FLAT WASHER	
24	2	618441	1 5/16MJIC-90-1 5/16MJIC LBO	
25	4	920504	1/2 LOCK WASHER	
26	6	920505	5/8 LOCK WASHER	
27	1	358670	RH LEG BRACE WLD 280	92
28	1	358759	LEG MT V-PLT WLD, 284T	94
29	9	470140	5/8UNF HEX SMTH FLANGE NUT PLT	
30	3	900836	5/8UNF X 3 1/4 HEX BOLT GR8	
31	3	900837	5/8UNF X 3 1/2 HEX BOLT GR8	
32	1	900410	3/4UNC X 4" HEX BOLT	
33	1	910017	1" UNC HEX NUT	
34	1	914012	3/4UNC HEX STOVER NUT	
35	12	914811	5/8UNF HEX NUT GR8	
36	2	920008	1" SAE FLAT WASHER	
37	1	920508	1" LOCK WASHER	

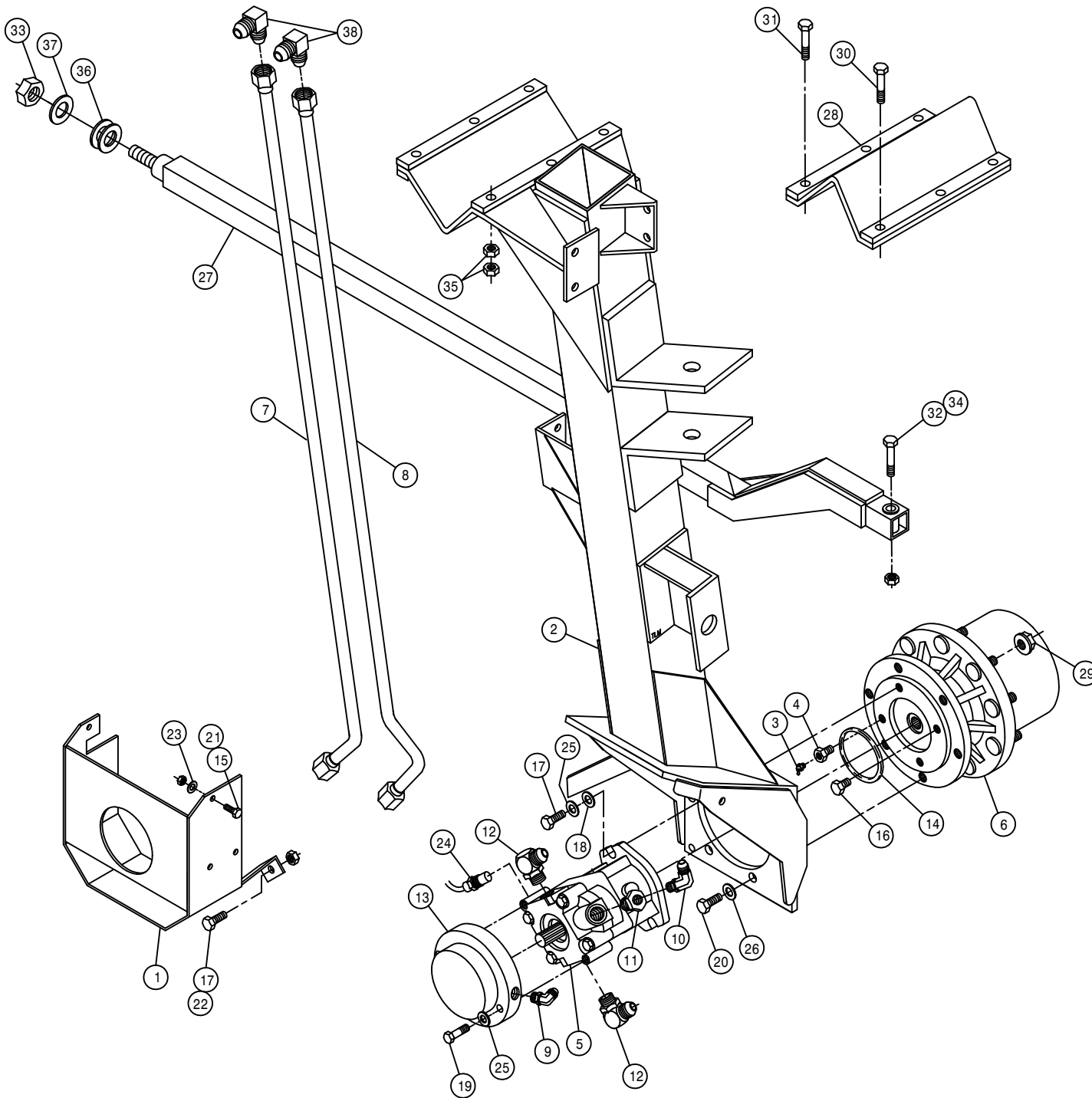

LEFT REAR LEG ASSEMBLY

DET.	QTY	PART NO.	DESCRIPTION
1	1	358824	LH REAR WHL MTR SHLD WLD 97
2	1	358828	LH REAR LEG WLD, 284 97
3	1	471023	GREASE ZERK 1/4-28 X 45
4	1	610556	1/2UNC X 1/2 ZERK BOLT T-HUB
5	1	610621	SUND HYD MOTOR
6	1	610692	TORQ HUB, 30:1 B-MT MW3BA
7	1	615705	REAR LEG HYD TUBE ASSY 284 97
8	1	615707	LH REAR LEG HYDTUBE ASSY284 97
9	1	618114	9/16MJIC-90-7/16MOR LBO
10	1	618119	9/16MJIC-90-9/16MOR LBO
11	1	618172	7/8MOR-9/16FOR ADPTR
12	2	618576	1 5/16MJIC-90-1 1/16MOR LBO
13	1	828092	MICO HYD BRAKE
14	1	870045	O-RING 4 1/8 OD X 4 ID
15	2	900130	3/8UNC X 1 1/4 HEX BOLT
16	1	900260	1/2UNC X 1/2 H BOLT GR2 UNPLT
17	4	900265	1/2UNC X 1 1/2 HEX BOLT
18	2	920004	1/2 SAE FLAT WASHER
19	2	900268	1/2UNC X 2 1/2 HEX BOLT
20	6	900333	5/8UNC X 1 1/2 HEX BOLT
21	2	914004	3/8UNC HEX STOVER NUT
22	2	914008	1/2UNC HEX STOVER NUT
23	2	920002	3/8 SAE FLAT WASHER
24	1	610625	SENSOR FOR SUND WHL MOTOR
25	4	920504	1/2 LOCK WASHER
26	6	920505	5/8 LOCK WASHER
27	1	358671	LH LEG BRACE WLD 280 92
28	1	358759	LEG MT V-PLT WLD, 284T 94
29	9	470140	5/8UNF HEX SMTH FLANGE NUT PLT
30	3	900836	5/8UNF X 3 1/4 HEX BOLT GR8
31	3	900837	5/8UNF X 3 1/2 HEX BOLT GR8
32	1	900410	3/4UNC X 4" HEX BOLT
33	1	910017	1" UNC HEX NUT
34	1	914012	3/4UNC HEX STOVER NUT
35	12	914811	5/8UNF HEX NUT GR8
36	2	920008	1" SAE FLAT WASHER
37	1	920508	1" LOCK WASHER
38	2	618441	1 5/16MJIC-90-1 5/16MJIC LBO

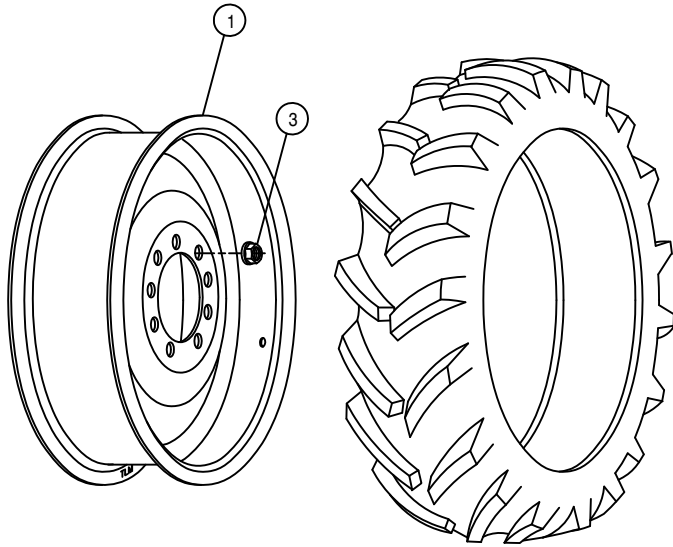

13.6-28 RADIAL TIRE

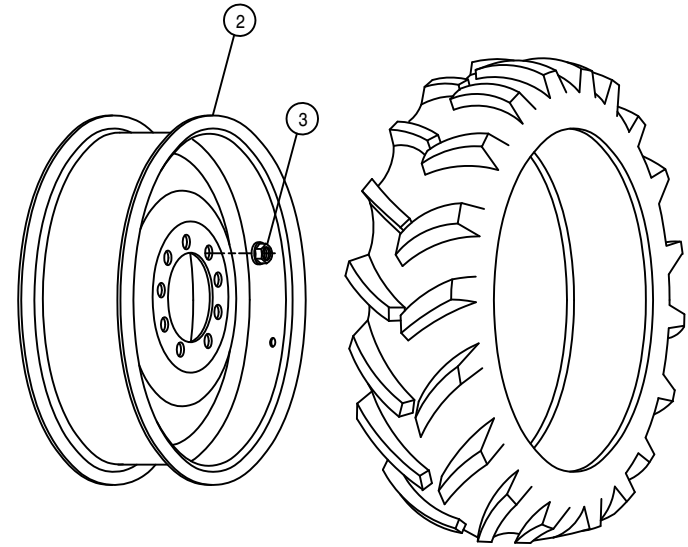

12.4-28 BIAS TIRE

TIRE AND RIM ASSEMBLIES

DET. QTY PART NO. DESCRIPTION

1	1	821045	RIM WLD, W12-28, 284	98
2	1	821047	RIM WLD, W10-28, 284	98
3	18	470140	5/8UNF HEX SMTH FLANGE NUT PLT	

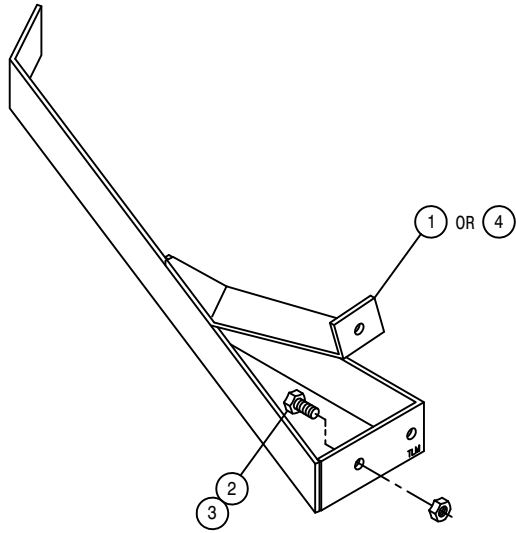

CROP GUIDES

DET. QTY PART NO. DESCRIPTION

1	1	662217	RH REAR STALK GUIDE WLD280	89
2	2	900129	3/8UNC X 1 HEX BOLT	
3	2	914004	3/8UNC HEX STOVER NUT	
4	1	662218	LH REAR STALK GUIDE WLD280	89
5	1	662221	RH STALK GUIDE WLD	284 94
6	1	662222	LH STALK GUIDE WLD	284 94
7	2	900264	1/2UNC X 1 1/4 HEX BOLT	
8	2	914008	1/2UNC HEX STOVER NUT	
9	2	920004	1/2 FLAT WASHER SAE	

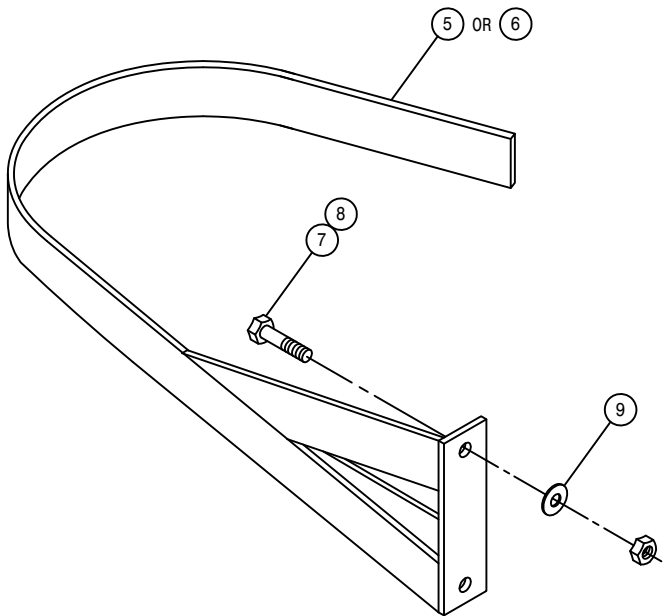

FRONT LEG CYLINDER ASSEMBLY

DET. QTY PART NO. DESCRIPTION

1	1	472297	3/4UNF HEX STOVER NUT THIN
2	1	620321	VEE PACK 1 1/2 X 2
3	1	620571	TUBE WLD
4	1	620573	SHAFT 1 1/4 X 17 3/8
5	1	620574	BRG HEAD 2 X 1 1/4
6	1	629002	WIPER 1 1/4 X 1 1/2 X 1/8
7	1	620578	PISTON 2 X 3/4 VPX
8	1	620579	RETAINER 2 X 3/4 X 1/4
9	1	870018	NEO ORING 3/4 X 7/8

NOTE: 620570 - CYLINDER ASSEMBLY
620575 - SEAL KIT

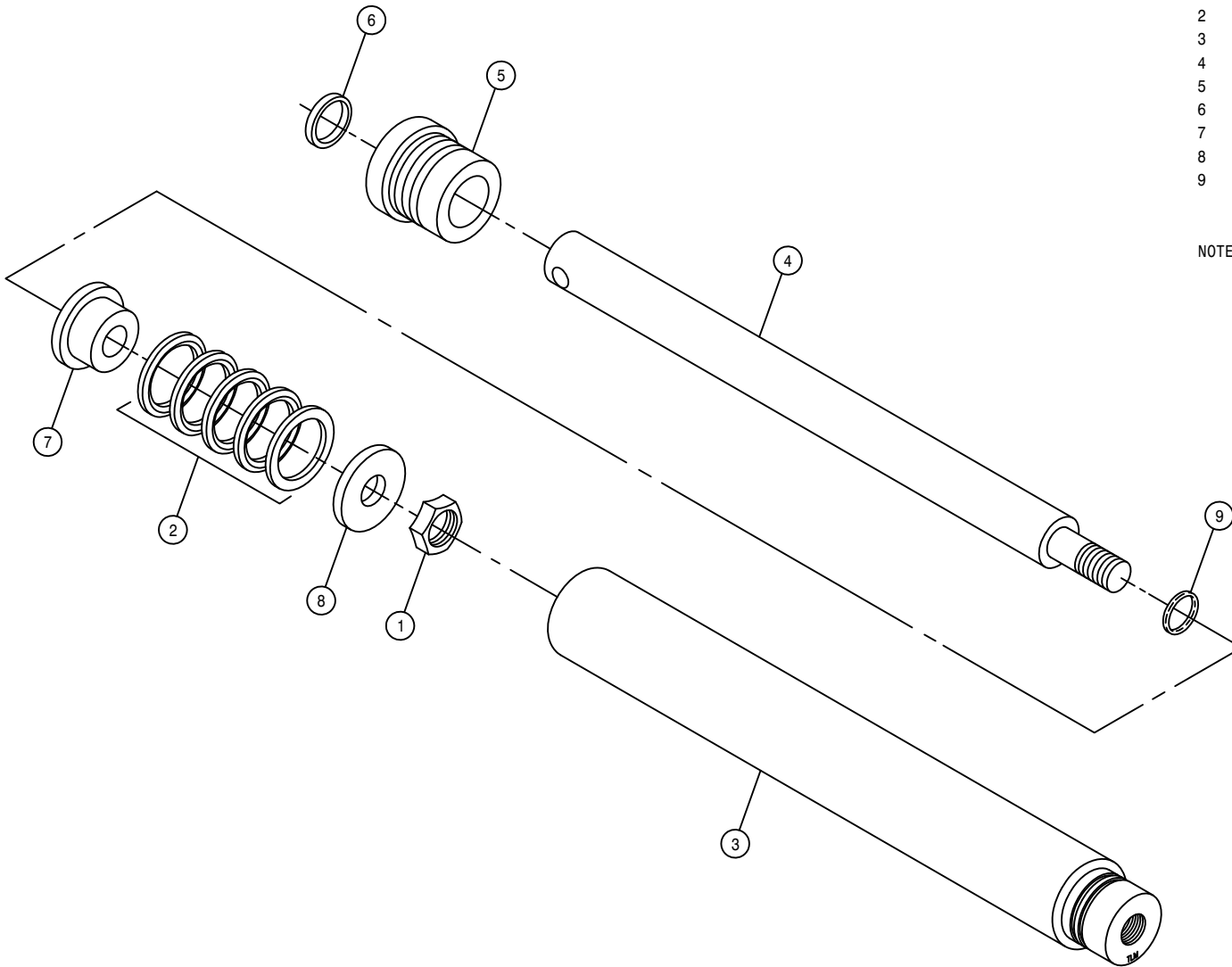

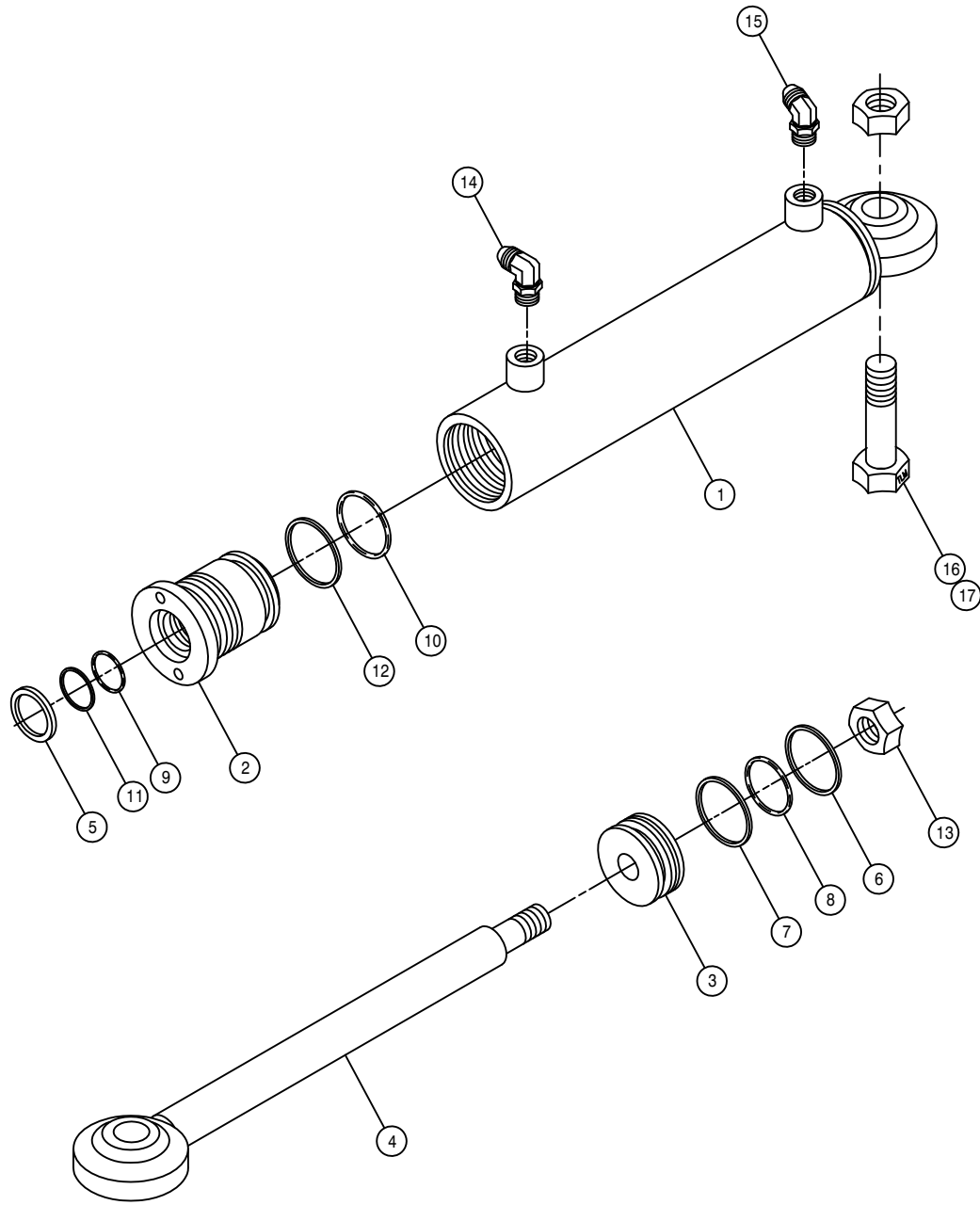

STEERING CYLINDER ASSEMBLY

DET. QTY PART NO. DESCRIPTION

1	1	620089	STRG CYL TUBE WLD 1.5 X 6. 85
2	1	620109	GLAND HYD CYL 1.5 X .75 1985
3	1	620129	PISTON HYD CYL 1.5 X .5 1985
4	1	620148	STRG CYL SHAFT WLD
5	1	629028	WIPER, 10D X 3/4ID X 1/8
6	1	629616	SEAL, 1704-24 HT20550R POLYHON
7	1	629618	WEAR RING, 1.5" HYD CYL
8	1	870025	BUNA ORING 1 3/16 X 1 5/16
9	1	870210	BUNA ORING 3/4 X 1
10	1	870218	BUNA ORING 1 1/4 X 1 1/2
11	1	890210	BACKUP WASH 3/4 X1 HT2022
12	1	890218	BACKUP WASH1 1/4X1 1/2 HT2022
13	1	914009	1/2UNF HEX STOVER NUT
14	1	611122	9/16MJIC-90-1/4MNPT LBO
15	1	618338	9/16MJIC-45-1/4MNPT LBO
16	1	900336	5/8UNC X 2 1/2 HEX BOLT
17	1	914010	5/8UNC HEX STOVER NUT

NOTE: 1. 620080 - CYLINDER ASSEMBLY

2. 620998 - SEAL KIT

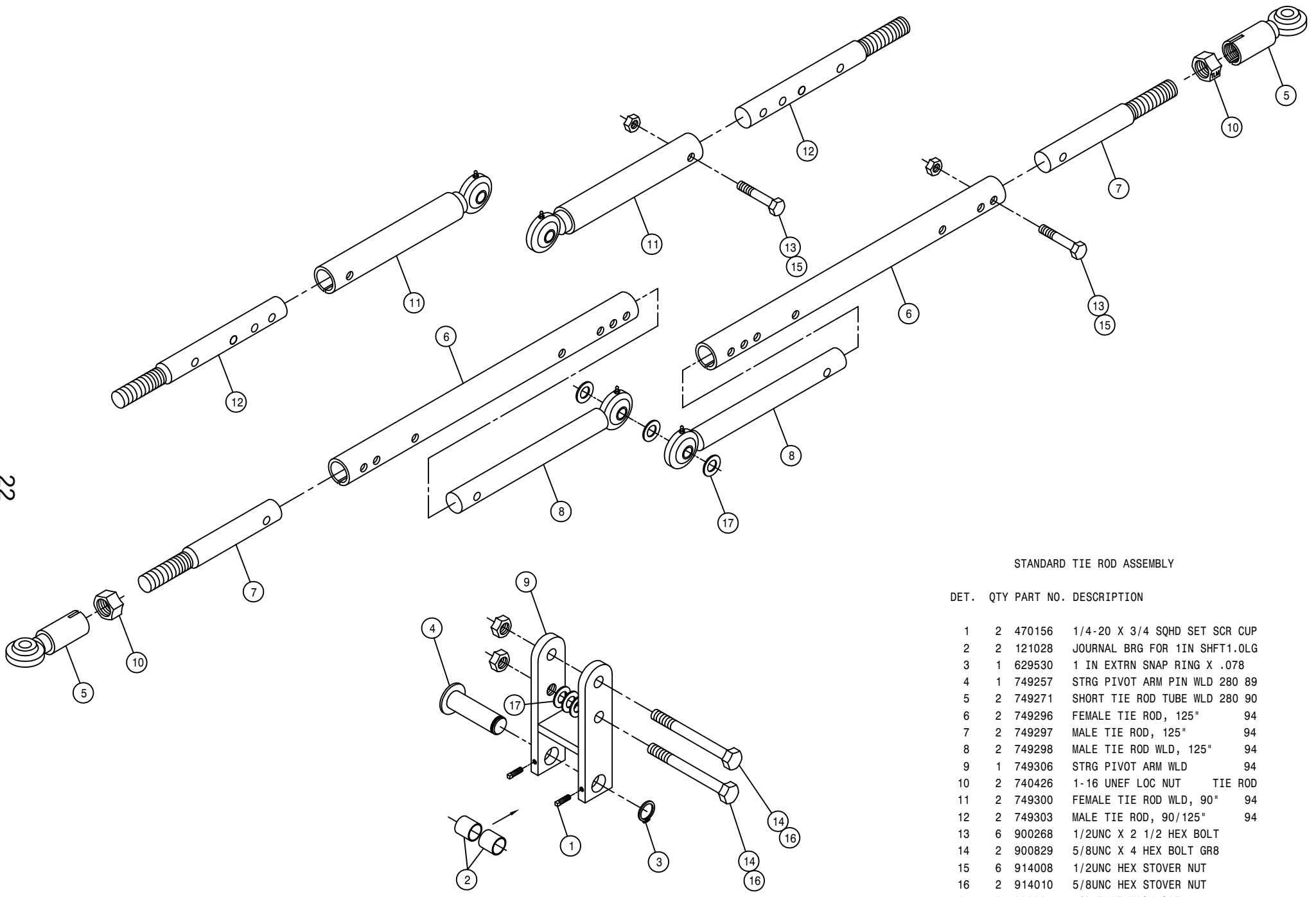

STANDARD TIE ROD ASSEMBLY

DET.	QTY	PART NO.	DESCRIPTION
1	2	470156	1/4-20 X 3/4 SQHD SET SCR CUP
2	2	121028	JOURNAL BRG FOR 1IN SHFT1.0LG
3	1	629530	1 IN EXTRN SNAP RING X .078
4	1	749257	STRG PIVOT ARM PIN WLD 280 89
5	2	749271	SHORT TIE ROD TUBE WLD 280 90
6	2	749296	FEMALE TIE ROD, 125" 94
7	2	749297	MALE TIE ROD, 125" 94
8	2	749298	MALE TIE ROD WLD, 125" 94
9	1	749306	STRG PIVOT ARM WLD 94
10	2	740426	1-16 UNEF LOC NUT TIE ROD
11	2	749300	FEMALE TIE ROD WLD, 90" 94
12	2	749303	MALE TIE ROD, 90/125" 94
13	6	900268	1/2UNC X 2 1/2 HEX BOLT
14	2	900829	5/8UNC X 4 HEX BOLT GR8
15	6	914008	1/2UNC HEX STOVER NUT
16	2	914010	5/8UNC HEX STOVER NUT
17	6	920005	5/8 FLAT WASH SAE

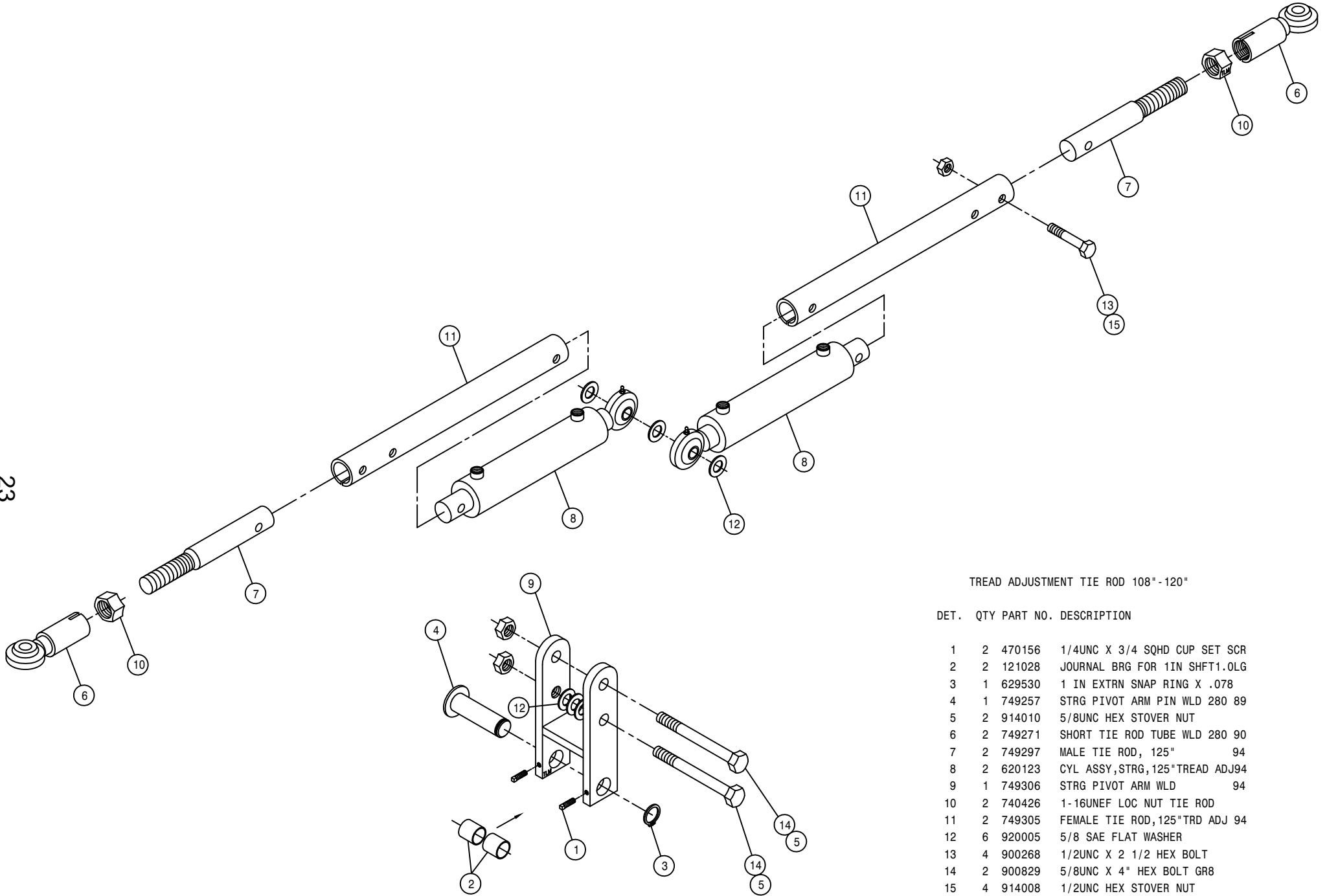

TREAD ADJUSTMENT TIE ROD 108" - 120"

DET.	QTY	PART NO.	DESCRIPTION
	2	470156	1/4UNC X 3/4 SQHD CUP SET SCR
	2	121028	JOURNAL BRG FOR 1IN SHFT1.0LG
	1	629530	1 IN EXTRN SNAP RING X .078
	1	749257	STRG PIVOT ARM PIN WLD 280 89
	2	914010	5/8UNC HEX STOVER NUT
	2	749271	SHORT TIE ROD TUBE WLD 280 90
	2	749297	MALE TIE ROD, 125" 94
	2	620123	CYL ASSY,STRG,125"TRD ADJ94
	1	749306	STRG PIVOT ARM WLD 94
	2	740426	1-16UNEF LOC NUT TIE ROD
	2	749305	FEMALE TIE ROD,125"TRD ADJ 94
	6	920005	5/8 SAE FLAT WASHER
	4	900268	1/2UNC X 2 1/2 HEX BOLT
	2	900829	5/8UNC X 4" HEX BOLT GR8
	4	914008	1/2UNC HEX STOVER NUT

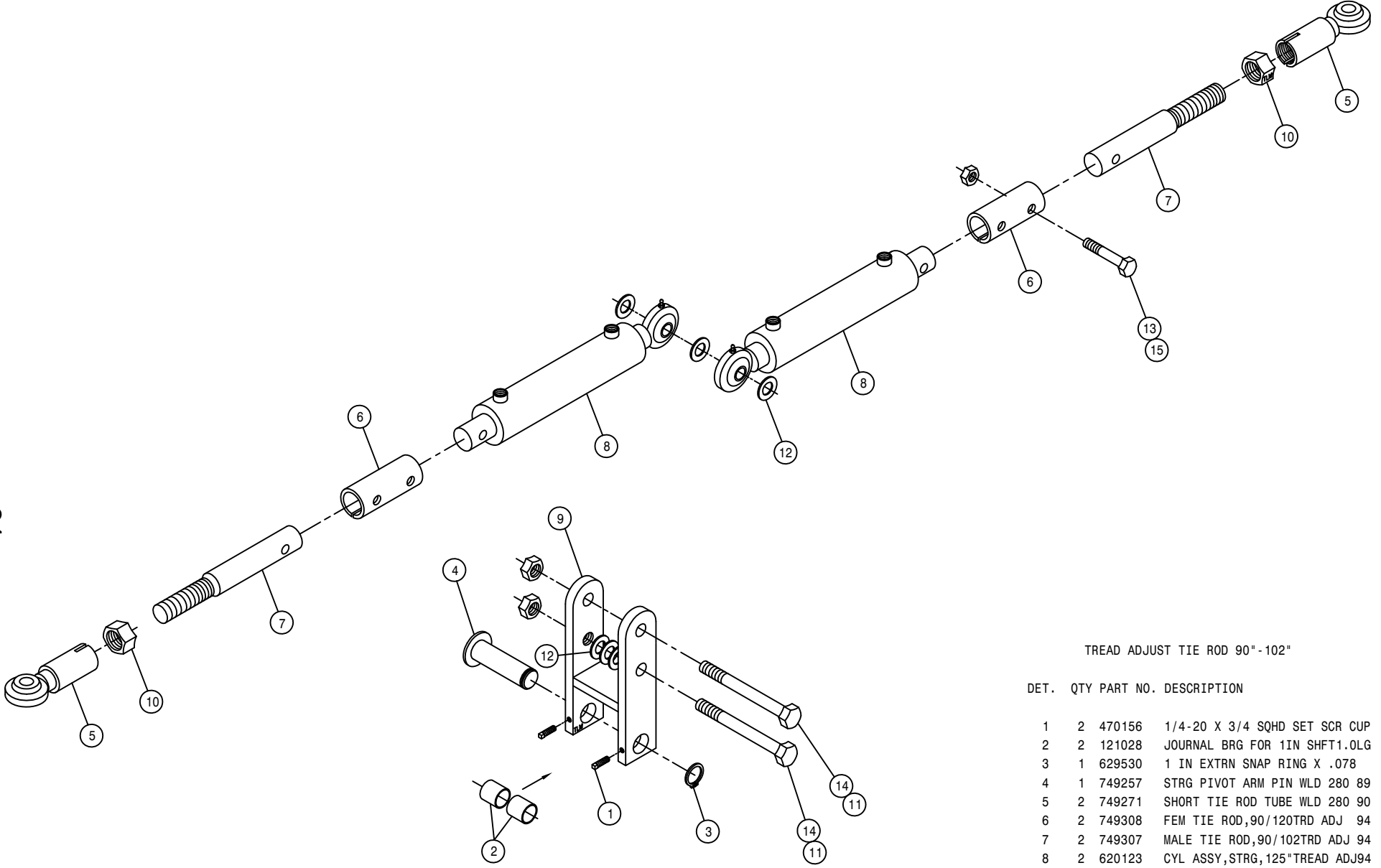

TREAD ADJUST TIE ROD 90" - 102"

DET.	QTY	PART NO.	DESCRIPTION
	1	2	470156 1/4-20 X 3/4 SQHD SET SCR CUP
	2	121028	JOURNAL BRG FOR 1IN SHFT1.0LG
	3	629530	1 IN EXTRN SNAP RING X .078
	4	749257	STRG PIVOT ARM PIN WLD 280 89
	5	749271	SHORT TIE ROD TUBE WLD 280 90
	6	749308	FEM TIE ROD,90/120TRD ADJ 94
	7	749307	MALE TIE ROD,90/102TRD ADJ 94
	8	620123	CYL ASSY,STRG,125" TREAD ADJ94
	9	749306	STRG PIVOT ARM WLD
	10	2	740426 1-16 UNEF LOC NUT TIE ROD
	11	2	914010 5/8UNC HEX STOVER NUT
	12	6	920005 5/8 FLAT WASH SAE
	13	4	900268 1/2UNC X 2 1/2 HEX BOLT
	14	2	900829 5/8UNC X 4 HEX BOLT GR8
	15	4	914008 1/2UNC HEX STOVER NUT

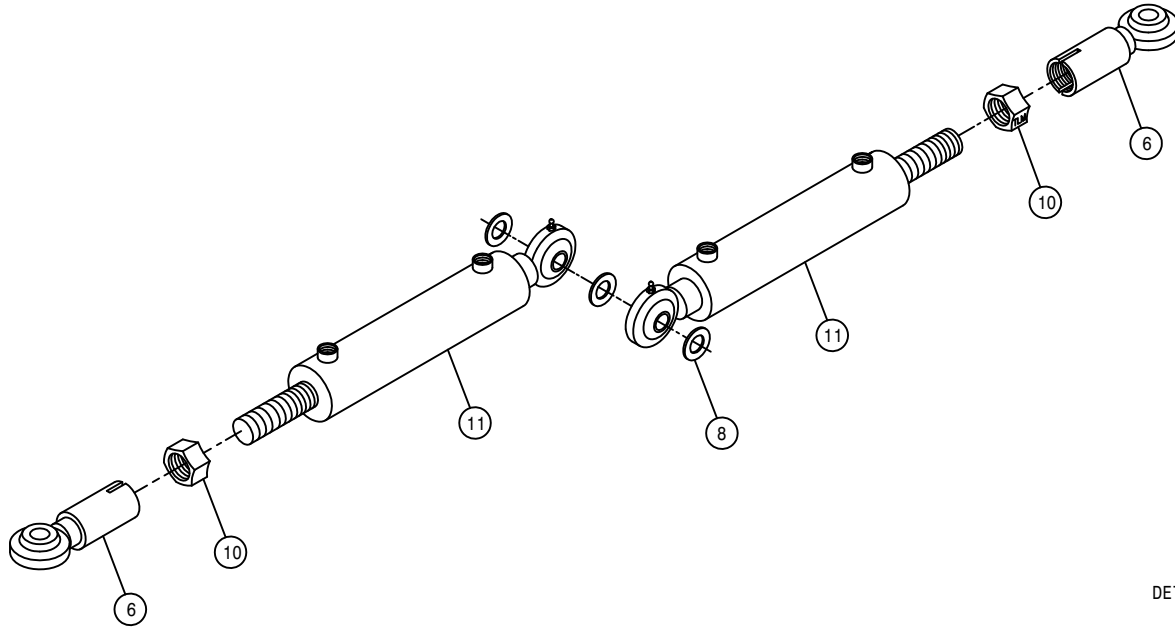

TREAD ADJUST TIE ROD 78" -90"

DET. QTY PART NO. DESCRIPTION

DET.	QTY	PART NO.	DESCRIPTION
1	2	470156	1/4-20 X 3/4 SQHD SET SCR CUP
2	2	121028	JOURNAL BRG FOR 1IN SHFT1.0LG
3	1	629530	1 IN EXTRN SNAP RING X .078
4	1	749257	STRG PIVOT ARM PIN WLD 280 89
5	2	900829	5/8UNC X 4 HEX BOLT GR8
6	2	749271	SHORT TIE ROD TUBE WLD 280 90
7	2	914010	5/8UNC HEX STOVER NUT
8	6	920005	5/8 FLAT WASH SAE
9	1	749306	STRG PIVOT ARM WLD 94
10	2	740426	1-16 UNEF LOC NUT TIE ROD
11	2	620122	CYL ASSY,STRG,90"TREAD ADJ 94

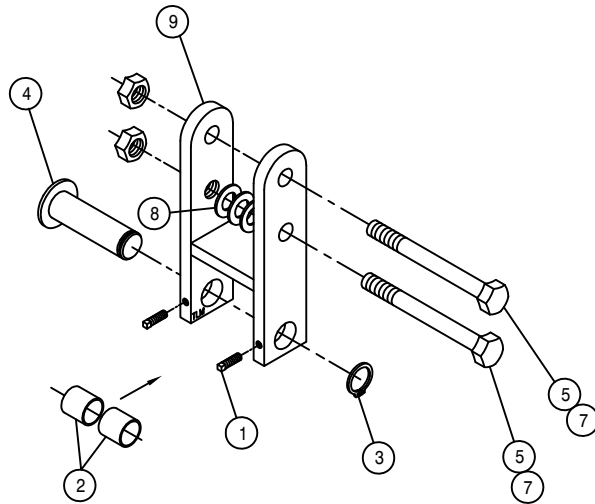

FUEL TANK ASSEMBLY

DET. QTY PART NO. DESCRIPTION

1	2	291428	FUEL SENDER 19 IN.	
2	10	473902	NO 8 X 1/2 PAN HD MET SC	
3	2	501102	1/4 PIPE PLUG	
4	4	501451	BLK PIPE EL 90DEG .25NPT	
5	2	760149	FUEL TANK WLD 200-280	90
6	2	761200	GAS CAP	
7	2	783303	1/4 NPT X 5/16 HOSE BARB, BRS	
8	2	601324	HOSE, 3/8 X 90" FUEL LINE	
9	1	760153	RH FUEL TNK MT WLD 200-280 90	
10	1	760154	LH FUEL TNK MT WLD 200-280 90	
11	4	760162	FUEL TANK BAND WLD 200-280 90	
12	1	610529	FUEL SELECTOR VALVE W/RETURN	
13	1	610530	5 WIRE CONNECTOR FOR 610529	
14	1	601421	HOSE, 5/16 X 50" FUEL LINE	
15	8	914008	1/2UNC HEX STOVER NUT	
16	2	601301	HOSE, 5/16 X 90" FUEL LINE	
17	10	520120	HOSE CLAMP NO 4 STAINLESS	
18	2	900064	5/16UNC X 3/4 HEX BOLT	
19	4	914004	3/8UNC HEX STOVER NUT	
20	8	900264	1/2UNC X 1 1/4 HEX BOLT	
21	2	783304	1/4 NPT X 3/8 HOSE BARB, BRS	
22	1	601322	HOSE, 3/8 X 26" FUEL LINE	

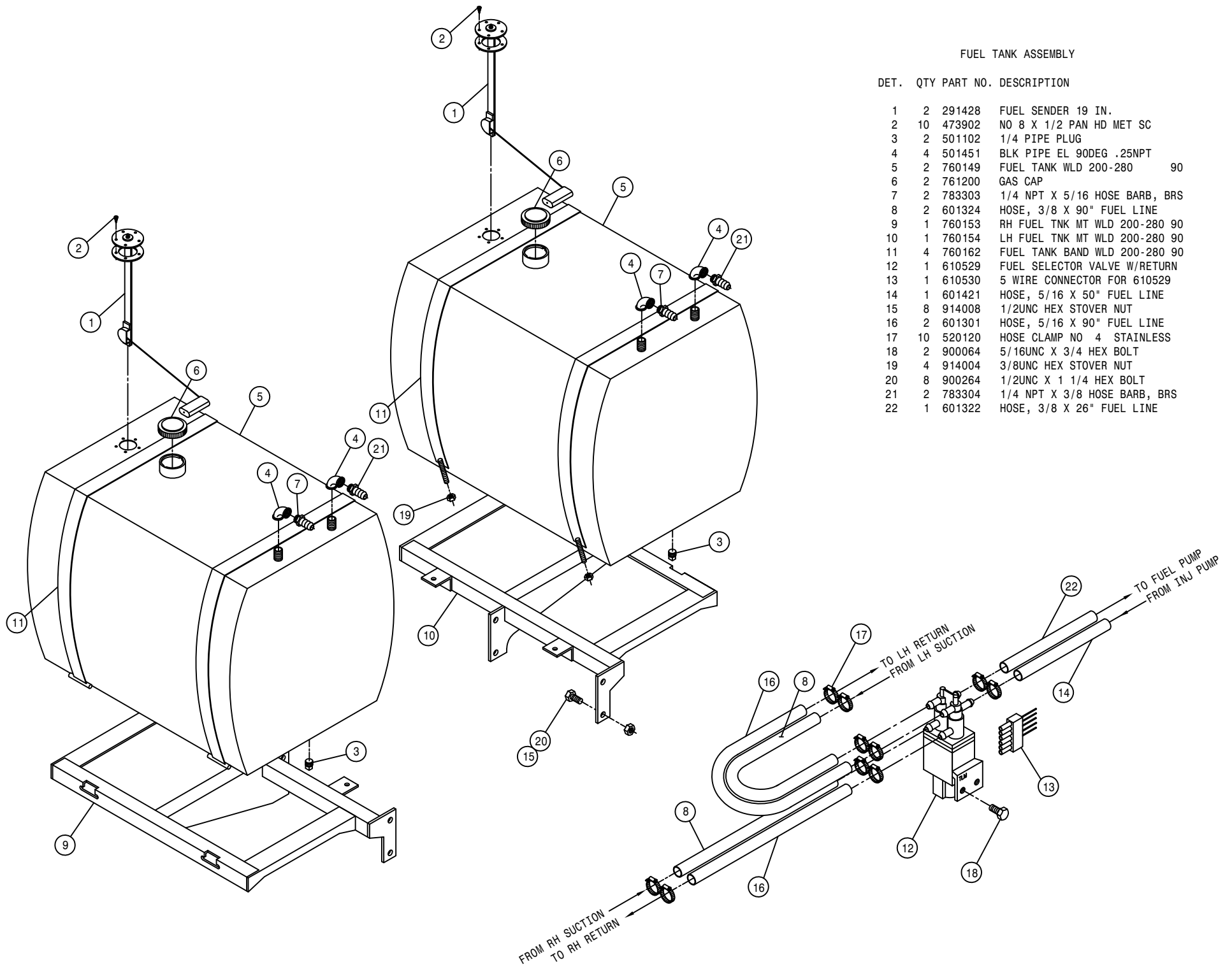

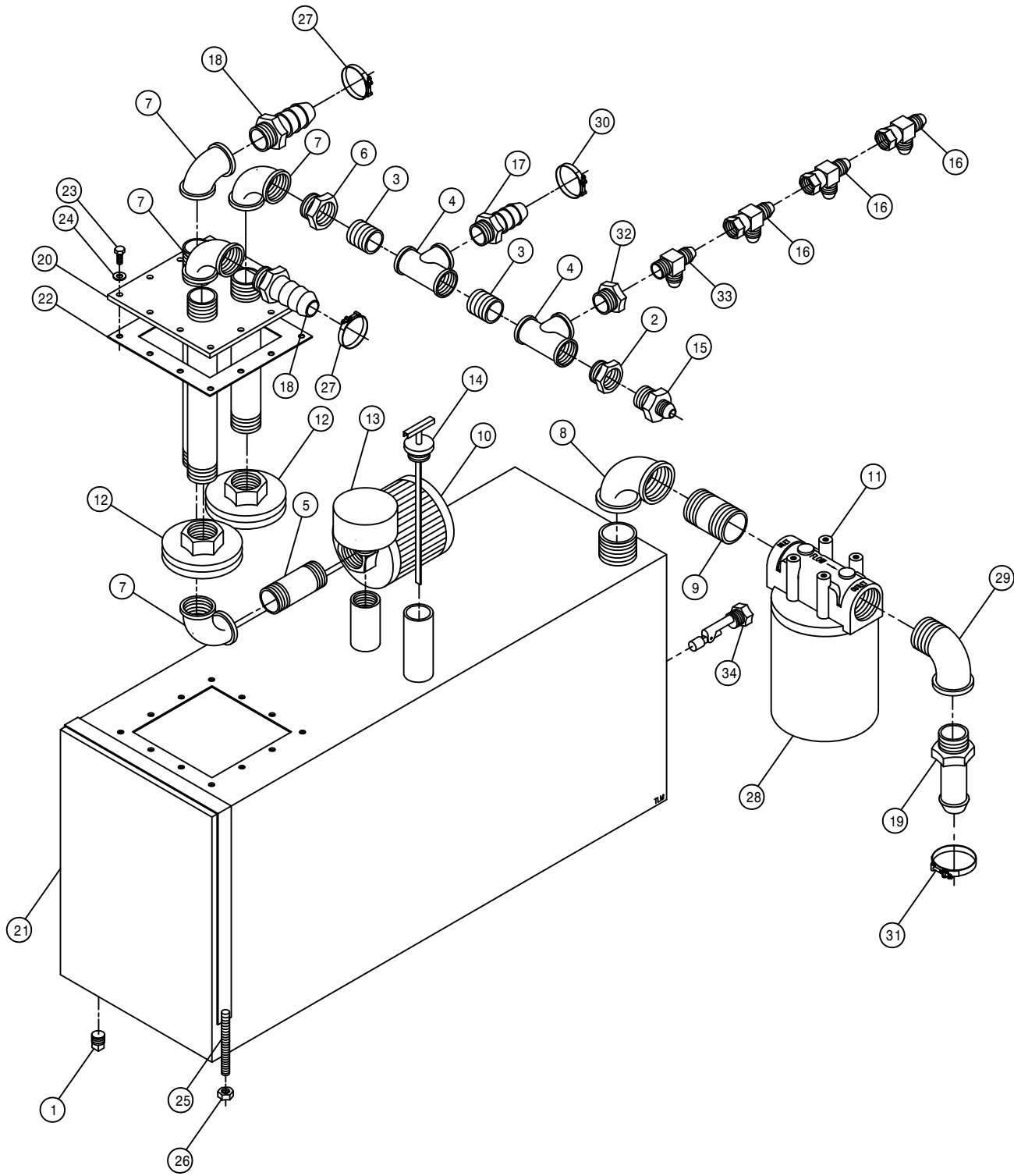

HYDRAULIC TANK ASSEMBLY

DET.	QTY	PART NO.	DESCRIPTION
	1	501102	1/4 PIPE PLUG
	2	504210	RED BUSH 3/4 NPT X 1/2 NPT
	3	504702	CLOSE NIPPLE .75NPT
	4	504955	BLK PIPE TEE .75NPT
	5	505203	BLK PIPE NIPPLE 1.00NPT-4.00
	6	505213	RED BUSH 1 X 3/4 BLK MAL
	7	505300	BLK PIPE EL 90DEG 1.00NPT
	8	506303	BLK PIPE EL 90DEG 1.25NPT
	9	506602	PIPE NIPPLE 1 1/4NPT-2 1/2
	10	605600	MICHIGAN RESERVOIR FILTER
	11	605601	GRESEN FILTER 10 MICRON 40GPM
	12	605603	LINE SUMP DIFFUSER
	13	611052	FILLER BREATHER 3/4NPT
	14	614453	DIPSTICK, 8IN
	15	618018	9/16MJIC-1/2MNPT ADPTR
	16	618486	9/16FJIC SW RUN TEE-9/16MJIC
	17	713220	HOSE BARB 3/4 NPT X 3/4
	18	714560	1NPT X 1 HOSE BARB
	19	715660	HOSE BARB 1 1/4NPT X 1 1/4
	20	760090	RECEIVER PLT WLD 8240
	21	760097	OIL TANK WLD 8240 1982
	22	763039	HYD MTR MTG PLT GSKT
	23	900064	5/16UNC X 3/4 HEX BOLT
	24	920001	5/16 SAE FLAT WASHER
	25	341360	OIL TANK STRAP WLD 8240 1982
	26	914004	3/8UNC HEX STOVER NUT
	27	520138	1.00 T-BOLT HOSE CLAMP
	28	605602	FILT ELEMENT 10MICRON 40GPM
	29	506410	BLK PIPE ST EL 90DEG 1.25NPT
	30	520137	.75 T-BOLT HOSE CLAMP
	31	520132	1.62/1.87 T-BOLT HOSE CLAMP
	32	504001	RED BUSH 3/4 X 1/4 BLK MAL
	33	618520	1/4MNPT RUN TEE-9/16MJIC
	34	470290	LIQUID LEVEL SWITCH, 1/2MNPT

CAB ASSEMBLY

DET.	QTY	PART NO.	DESCRIPTION
1	1	290107	GROUND CABLE,8" X 4GA .406LUGS
2	4	311051	RUBBER MOUNT, RB3-350
3	4	311052	SNUBBING WASHER FOR 311051
4	24	193037	STICKERTITE 1/8 X 3/4
5	25	193044	WINDOW WEATHERSTRIP 94
6	25	193045	LOCK STRIP FOR 193044 94
7	13	192001	FILLR STRIP FOR WEATHERSTRIP
8	13	193018	2 P/C SELF SEAL WEATHERSTRIP
9	1	200019	.25 SCH 40BP X 1.00 LG C/L
10	1	202037	WINDSHIELD WIPER SPACER
11	1	290412	DIMMER SWITCH
12	1	290417	18" WIPER BLADE
13	4	900343	5/8UNC X 4 1/2 HEX BOLT
14	1	342330	CAB WELDMT, 284 97
15	1	342146	KICK PANEL WLD, 284 CAB 94
16	1	342150	CAB ROOF WLD, 284 94
17	1	342180	HEADLINER KPR ANGLE,284CAB 94
18	4	470067	RUBBER GROMMET 1/4 ID
19	2	470070	RUBBER GROMMET 3/8 ID
20	4	914010	5/8UNC HEX STOVER NUT
21	1	470229	IDENTIFICATION TIE, 3/4"
22	6	470100	3/8 INT TOOTH LOCK WASHER
23	13	470121	1/4UNC HEX FLANGE LOCK NUT
24	10	470122	1/4UNC X 1/2 FLANGE HEX BOLT
25	16	470212	1/4 X 5/8 BONDED SEALING WASH
26	16	470218	1/4UNC NUT J-TYPE CAGE CLIP
27	1	470222	GRAB HANDLE, BLACK MOULDED
28	12	472349	1/4 X 3/4 20THD-IN TEK TYPE
29	6	473779	10MM-1.50 HEX NUT
30	2	473910	1/4 X 1 1/2 PHIL HD SHT MTL S
31	2	650524	OUTSIDE REAR VIEW MIRROR
32	1	658008	WINDSHIELD WIPER MOTOR
33	1	658013	WIPER ARM
34	1	658014	FRONT CAB GLASS 94
35	1	658015	FRONT SIDE CAB/DOOR GLASS 94
36	2	658016	REAR SIDE CAB GLASS 94
37	1	658017	REAR CAB GLASS 94
38	8	900002	1/4UNC X 3/4 HEX BOLT
39	1	900005	1/4UNC X 1 1/2 HEX BOLT
40	6	291603	WORKLAMP, SIDE MT 12V HALOGEN
41	2	903883	10-32 X 1/2 SLT RDHD MACH SCR
42	2	903889	10-32 X 3/4 SLT RDHD MACH SCR
43	4	470175	10-32 HEX FLANGE LOCK NUT
44	14	195913	1/8 WINDSHIELD WASHER HOSE
45	1	914000	1/4UNC HEX STOVER NUT
46	1	914004	3/8UNC HEX STOVER NUT
47	2	342333	NYL HOSE SLEEVE,2.64ID X 12.00
48	1	629728	FINISH PLUG FOR 2.12 HOLE
49	11	470118	1/4UNC X 3/4 FLANGE HEX BOLT
50	2	659704	FOAM, 2"THK X 2" WIDE X 42"LG
51	1	290003	WINDSHIELD WASHER NOZZLE KIT
52	1	291569	3/8 X 6" HEAT SHRINK TUBE

*NOTE: DETAILS 18,51,52 AND 44 ARE USED WITH THE WINDSHIELD WASHER OPTION.

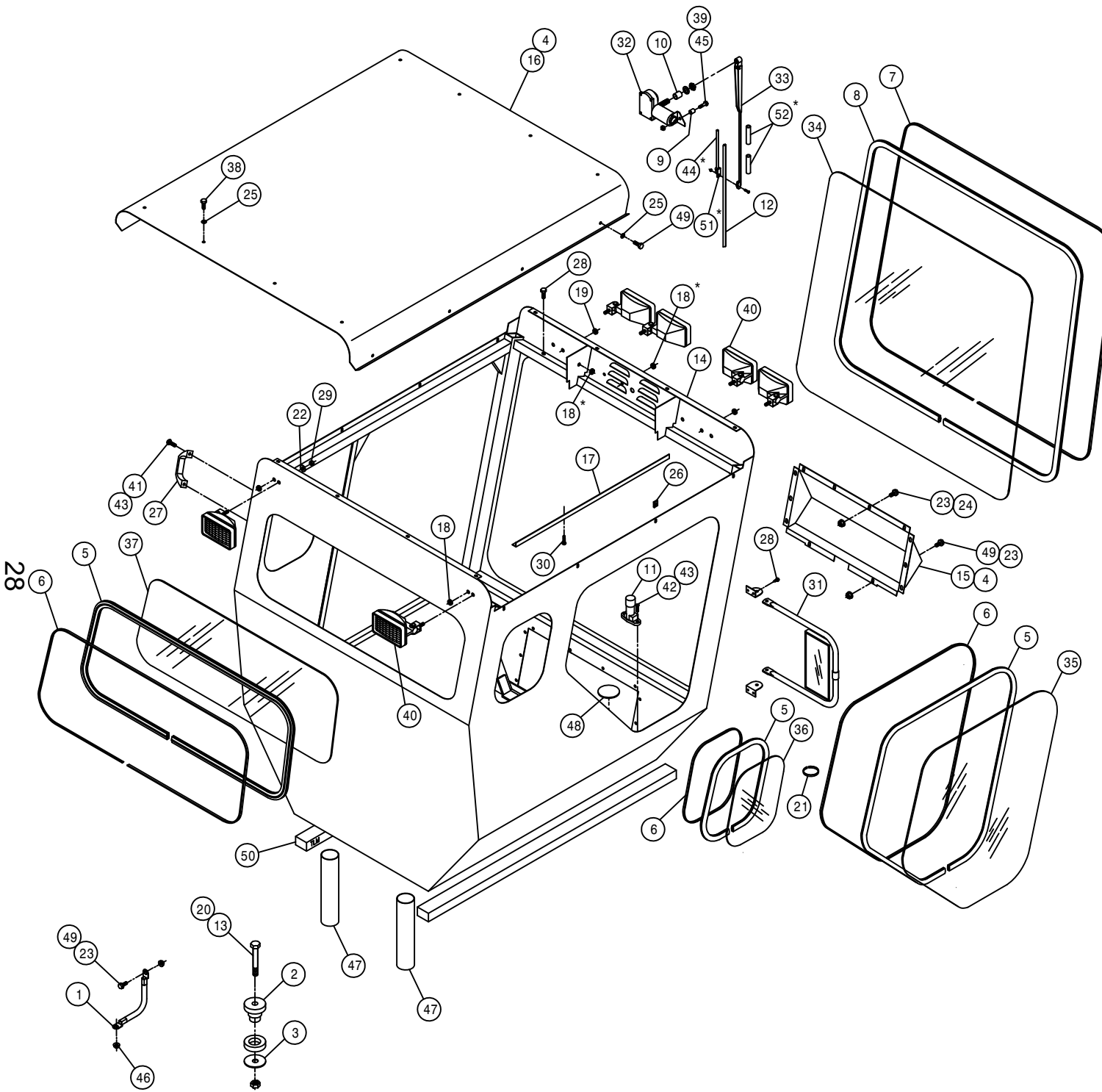

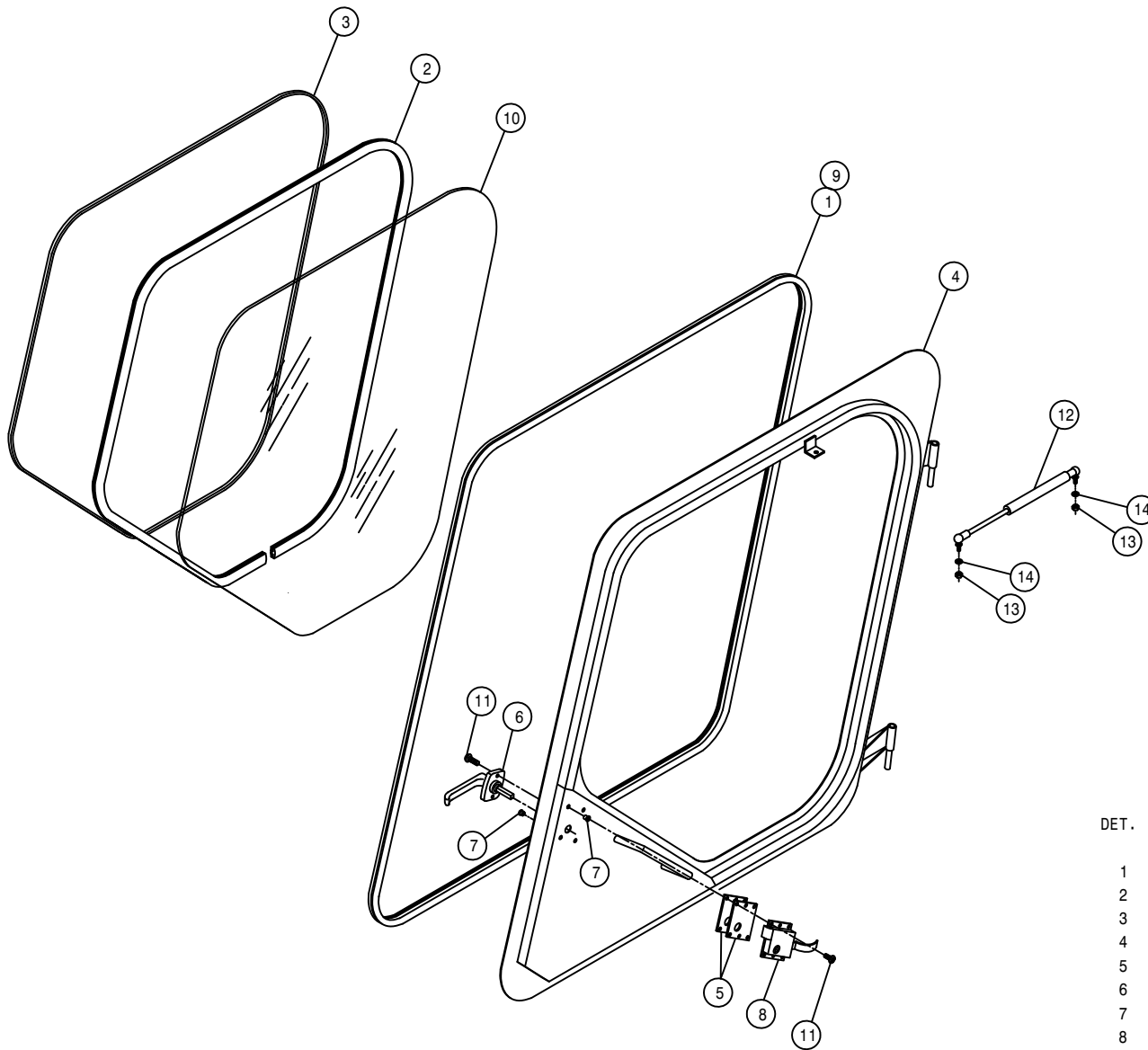

DOOR ASSEMBLY

DET. QTY PART NO. DESCRIPTION

1	12	193028	PUSH-ON TRIM SEAL RS-130-FX
2	9	193044	WINDOW WEATHERSTRIP 94
3	9	193045	LOCK STRIP FOR 193044 94
4	1	342153	LH DOOR WLD, 284 CAB 94
5	2	342163	CAB DOOR LATCH SHIM, .06 94
6	1	342217	DOOR HANDLE, 254/284 CAB 94
7	6	470165	10-32 NUTSERT .020-.100 MATL
8	1	470219	CAB LOCK, LH #55
9	2	485052	POP RIVET 1/8 X 3/8
10	1	658015	FRONT SIDE CAB/DOOR GLASS 94
11	6	903710	10-32X1/2 PHIL PANHD MACH SCR
12	1	470221	GAS SPRING, 60LB 3.5 STROKE
13	2	910002	5/16UNC HEX NUT
14	2	920501	5/16 LOCK WASHER

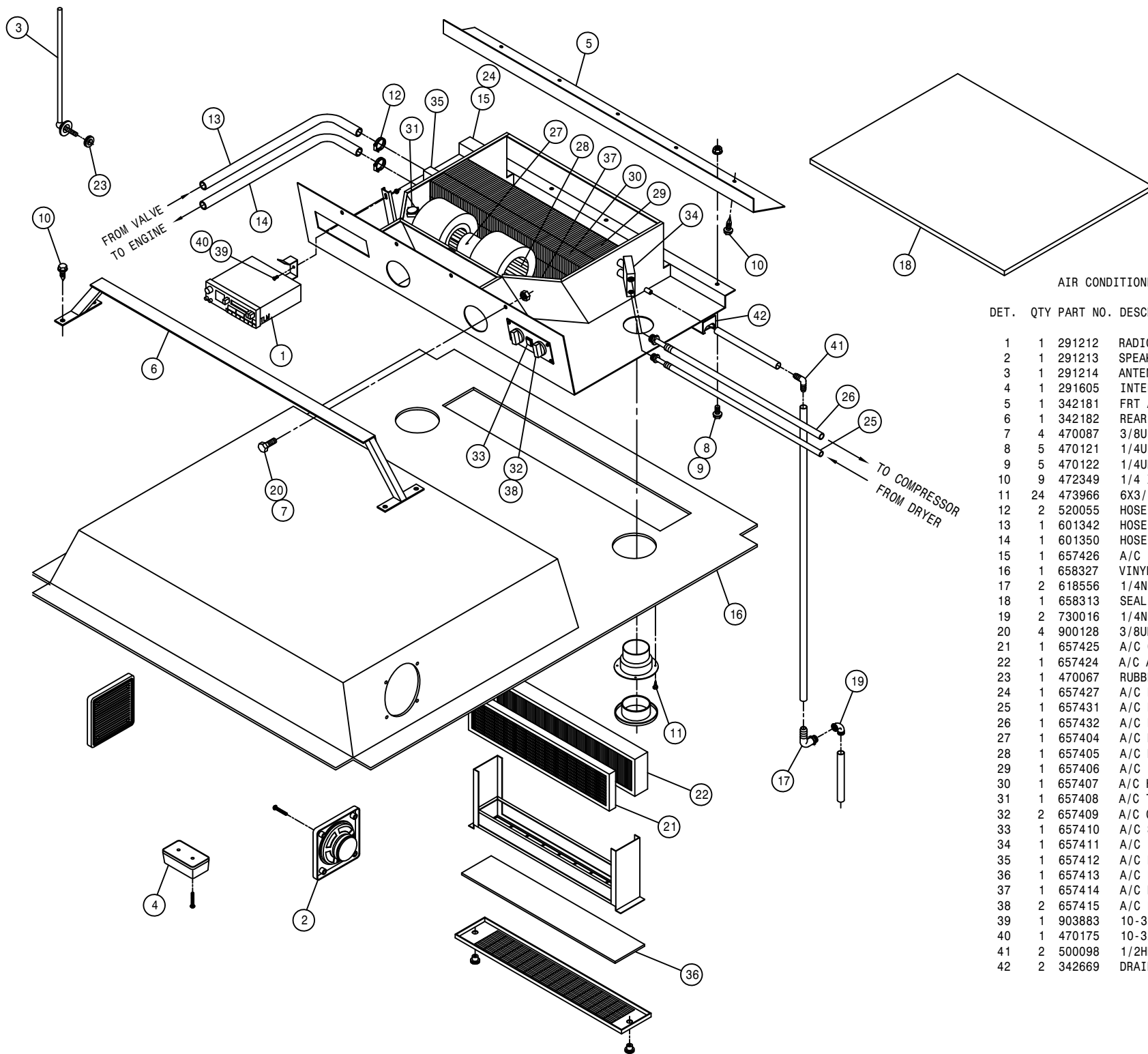

AIR CONDITIONER ASSEMBLY

DET. QTY PART NO. DESCRIPTION

1	1	291212	RADIO	94
2	1	291213	SPEAKERS (PAIR)	94
3	1	291214	ANTENNA	94
4	1	291605	INTERIOR LIGHT W/SWITCH	
5	1	342181	FRT A/C BLOWER MT ANG, CAB 94	
6	1	342182	REAR A/C BLOWER MT WLD,CAB 94	
7	4	470087	3/8UNC HEX FLANGE LOCK NUT	
8	5	470121	1/4UNC HEX FLANGE LOCK NUT	
9	5	470122	1/4UNC X 1/2 FLANGE HEX BOLT	
10	9	472349	1/4 X 3/4 20THD-IN TEK TYPE	
11	24	473966	6X3/4 PHIL FLT HD SHT MTL SCR	
12	2	520055	HOSE CLAMP NO 12 STAINLESS	
13	1	601342	HOSE, 5/8 X 192 HEATER	
14	1	601350	HOSE, 5/8 X 160 HEATER	
15	1	657426	A/C EVAPORATOR/HEATER, 284 MCC	
16	1	658327	VINYL HEAD LINER	99
17	2	618556	1/4NPT-90-1/2 HOSE BARB,POLY	
18	1	658313	SEAL, AIR CONDITIONER	94
19	2	730016	1/4NPT ST EL, 90 DEG POLY	
20	4	900128	3/8UNC X 3/4 HEX BOLT	
21	1	657425	A/C CHARCOAL AIR FILTER	MCC
22	1	657424	A/C AIR FILTER	MCC
23	1	470067	RUBBER GROMMET 1/4 ID	
24	1	657427	A/C HOSE KIT, EVAP 284, 99 MCC	
25	1	657431	A/C HOSE ASSY, 5/16 X 173 MCC	
26	1	657432	A/C HOSE ASSY, 1/2 X 190. MCC	
27	1	657404	A/C BLOWER MOTOR, 12V MCC	
28	1	657405	A/C BLOWER WHEEL W/CLIP MCC	
29	1	657406	A/C EVAPORATOR COIL	MCC
30	1	657407	A/C HEATER COIL	MCC
31	1	657408	A/C THERMOSTAT	MCC
32	2	657409	A/C CONTROL KNOB	MCC
33	1	657410	A/C SWITCH, PUSH ON-OFF MCC	
34	1	657411	A/C EXPANSION VALVE	MCC
35	1	657412	A/C HEATER VALVE,MOTORIZED MCC	
36	1	657413	A/C FILTER, RECIRCULATION MCC	
37	1	657414	A/C BLOWER DRIVE ASSY	MCC
38	2	657415	A/C POTENTIOMETER ASSY	MCC
39	1	903883	10-32 X 1/2 SLT RDHD MACH SCR	
40	1	470175	10-32 HEX FLANGE LOCK NUT	
41	2	500098	1/2HB-90-1/2 HOSE BARB, POLY	
42	2	342669	DRAIN HOSE KEEPER	

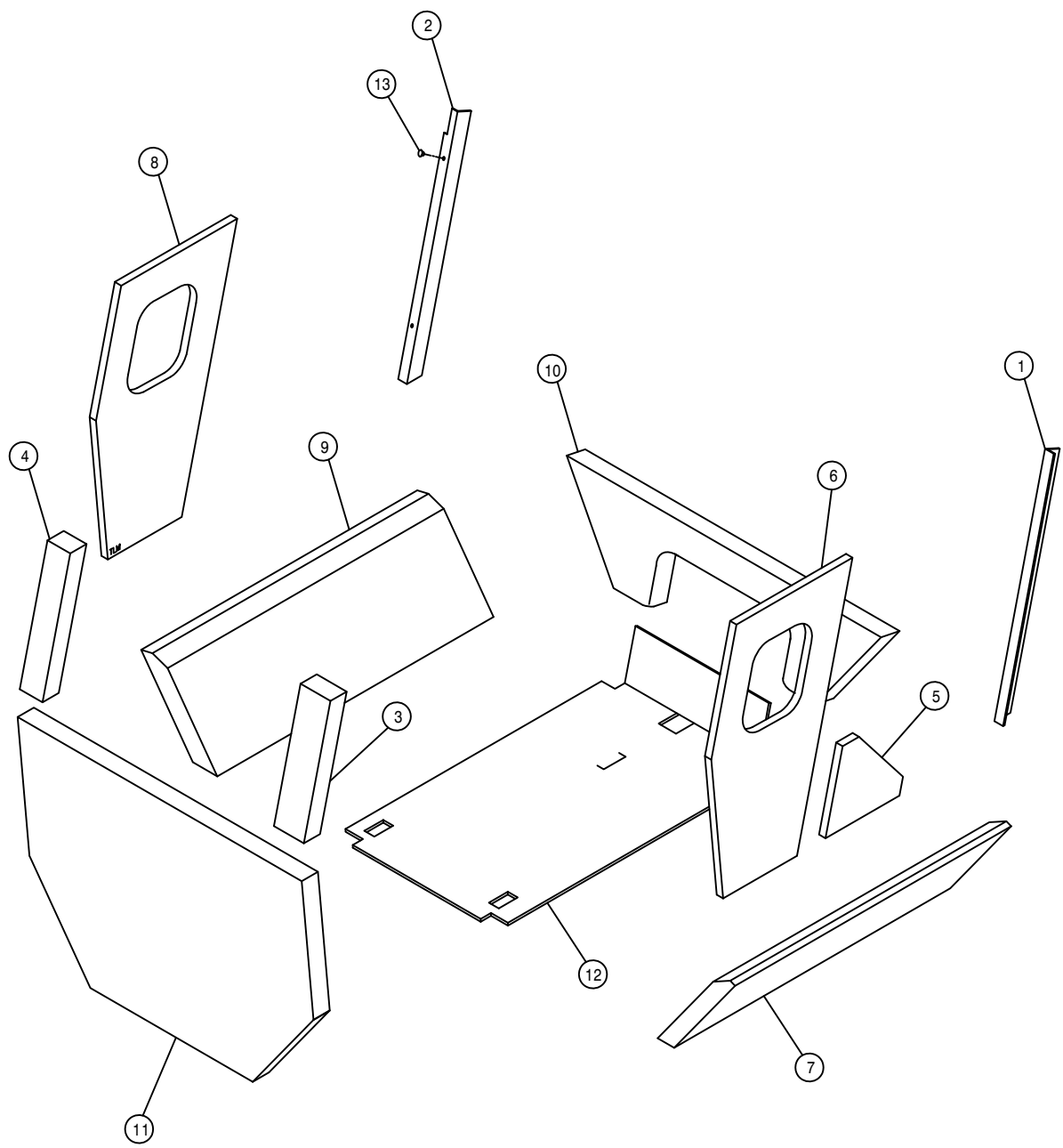

CAB FOAM

DET. QTY PART NO. DESCRIPTION

1	1	658301	VINYL POST COVER, RH FRONT	94
2	1	658302	VINYL POST COVER, LH FRONT	94
3	1	658303	VINYL POST COVER, RH REAR	94
4	1	658304	VINYL POST COVER, LH REAR	94
5	1	658305	VINYL SIDE PANEL, RH	94
6	1	658306	VINYL SIDE PANEL, RH UPPER	94
7	1	658307	VINYL SIDE PANEL, RH LOWER	94
8	1	658308	VINYL SIDE PANEL, LH UPPER	94
9	1	658309	VINYL SIDE PANEL, LH LOWER	94
10	1	658310	VINYL FRONT COVER PANEL	94
11	1	658311	VINYL REAR COVER PANEL	94
12	1	658316	CAB FLOORMAT, 284	97
13	2	470225	TRIM CLIP, 11/16 BLK NYL HEAD	

STEERING POST ASSEMBLY

DET. QTY PART NO. DESCRIPTION

1	1	221001	CONN LINK CLIP TYPE RC50
2	1	291088	FLASHER / TURN SIGNAL SWITCH
3	1	342165	STRG POST WLD, 284 CAB 94
4	1	342173	STRG POST ADJ PIN, 284 CAB 94
5	1	342174	STRG POST ADJ PIN LEVER WLD94
6	1	342177	STRG POST COVER, 284 CAB 94
7	1	342178	UPR STRG MTR HSNG COVER 94
8	1	342179	LWR STRG MTR HSNG COVER 94
9	2	390318	INDICATOR LIGHT, RED
10	4	470086	1/4UNC NUTSERT .020-.100MATL
11	1	470157	13/16-20UNEF HEX NUT STRG WHL
12	1	473939	ROLL PIN, 3/16DIA X 7/8
13	1	659291	KNOB, 1" RND, BLK, 3/8-16
14	1	749150	STRG MTR NON-LOAD REACT 1008
15	1	749178	STRG COLUMN 2.5IN LONG
16	1	749294	STEERING WHEEL, VIP 14"
17	1	749295	STRG WHL CAP W/HAGIE EMBLEM
18	13	903708	1/4UNC X 1/2 PHIL PNHD MACHSCR
19	1	914002	5/16UNC HEX STOVER NUT
20	1	914008	1/2UNC HEX STOVER NUT
21	1	900271	1/2UNC X 3 1/4 HEX BOLT
22	4	920001	5/16 SAE FLAT WASHER
23	4	920002	3/8 SAE FLAT WASHER
24	4	900130	3/8UNC X 1 1/4 HEX BOLT
25	4	618496	9/16MJIC-45-3/4MOR LBO
26	1	482131	3/4 X 1 3/4 COMPRN SPRING
27	1	470121	1/4UNC HEX FLANGE LOCK NUT

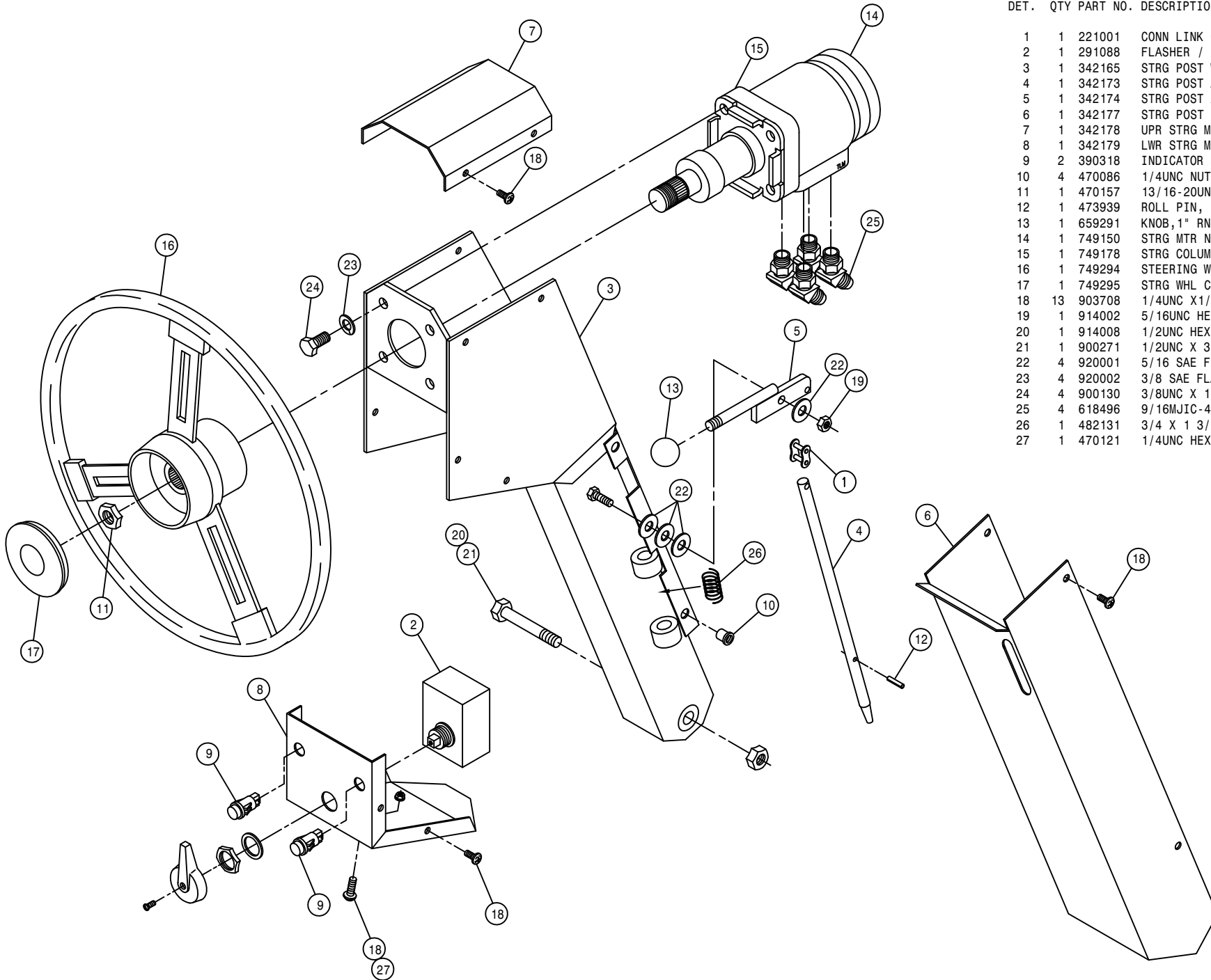

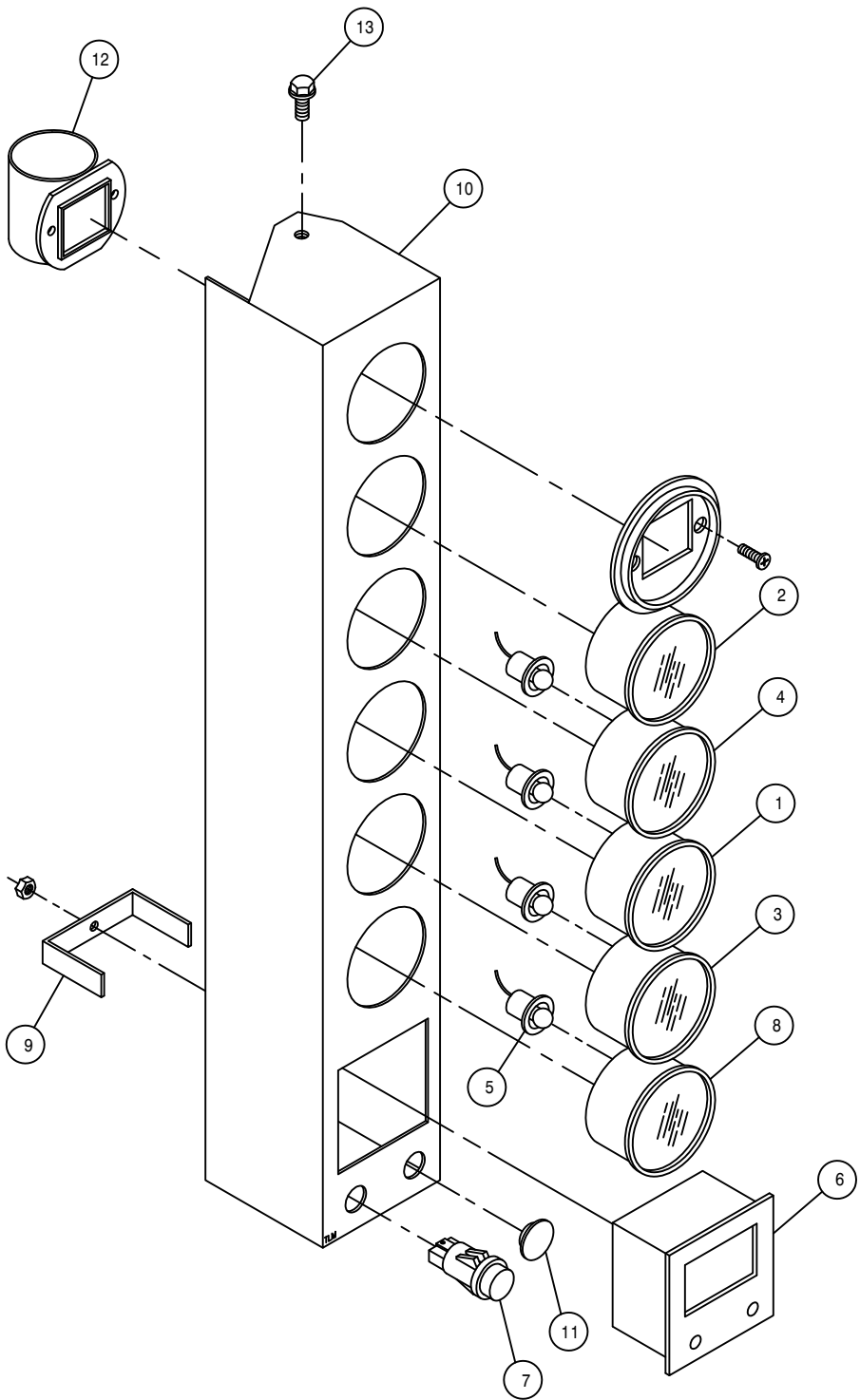

INSTRUMENT PANEL ASSEMBLY

DET. QTY PART NO. DESCRIPTION

1	1	290401	FUEL GAUGE FOR 2.125 DIA HOLE
2	1	291203	HOUR METER, 12/24VDC BLACK BEZ
3	1	291673	OIL PRESS GAUGE, 125PSI
4	1	291611	VOLTMETER, 8V TO 18V DC
5	4	291612	LIGHT KIT FOR 2" GAUGE
6	1	291635	DIGITAL MPH/RPM INDICATOR
7	1	291638	INDICATOR LIGHT, GREEN
8	1	314436	TEMP GA 100-280 DEG LIGHTED
9	1	342068	DIGITAL MPH/RPM IND KEEPER 94
10	1	342186	INSTRU HSG WLD, 284 CAB 94
11	1	658174	RUBBER BUMPER, 1.0000D .500GD
12	1	314901	FILTER MINDER AIR RESTRICT GA
13	2	470122	1/4UNC X 1/2 FLANGE HEX BOLT

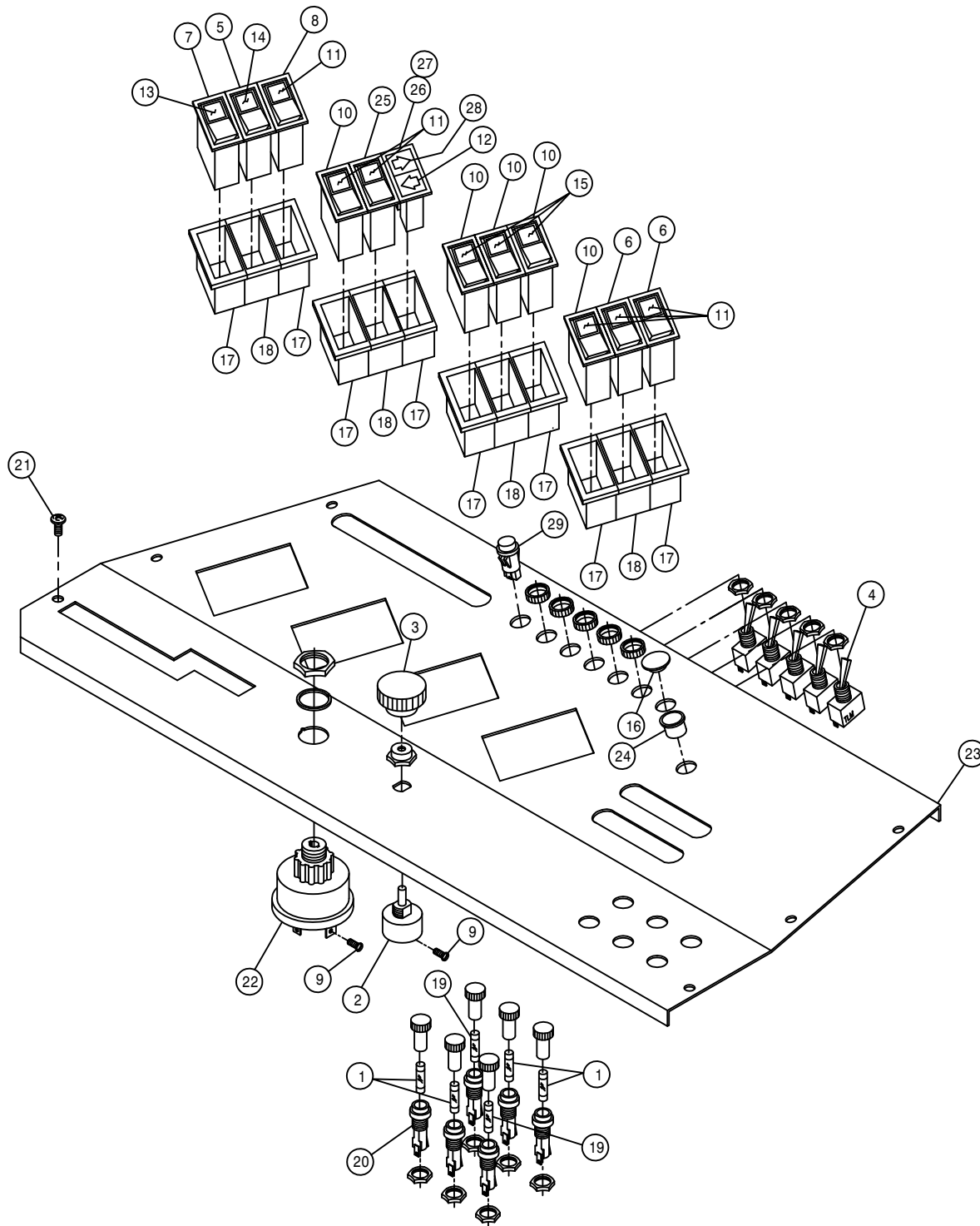

CONSOLE PANEL ASSEMBLY

DET.	QTY	PART NO.	DESCRIPTION
1	4	291602	FUSE 10 AMP
2	1	291606	ROTARY HEADLAMP SWITCH
3	1	291607	SWITCH KNOB FOR 291606
4	5	291608	TOGGLE SWITCH, ON-OFF, UNLIT
5	1	291622	SWITCH, 1P ON/OFF 511-003
6	2	291623	SWITCH, 2P ON/OFF 511-015
7	1	291678	SWITCH, 511-115
8	1	291625	SWITCH, 2P ON/ON 511-108
9	2	903844	8-32 X 1/2 SLT RD HD MACH SCR
10	5	291627	SWITCH, 2P(ON)OFF(ON) 511-058
11	6	291628	LENS, GREEN
12	1	291687	DIRECTION ARROW LENS, LH, YELLOW
13	1	291630	LENS, WINDSHIELD WASHER
14	1	291631	LENS, HAZARD
15	3	291632	LENS, DIRECTION INDICATOR
16	1	658174	RUBBER BUMPER, 1.0000D .500GD
17	8	293246	END BEZEL
18	4	293247	CENTER BEZEL
19	2	298004	20 AMP FUSE SFE 20
20	6	298011	FUSE HOLDER
21	6	903708	1/4UNC X1/2 PHIL PNHD MACHSCR
22	1	321020	IGN SWITCH, SEALED 5 POLE
23	1	342657	CONSOLE COVER PNL, 284 CUMM 99
24	1	470223	SNAP BUSHING, BLK NYL, .50DIA
25	1	291672	SWITCH, 1P ON/OFF/ON 511-149
26	1	291684	INDICATOR BASE W/LAMP 511-502
27	2	291685	REFLECTOR INSERT, 592-544
28	1	291686	DIRECTION ARROW LENS, RH, YELLOW
29	1	390318	INDICATOR LIGHT, RED

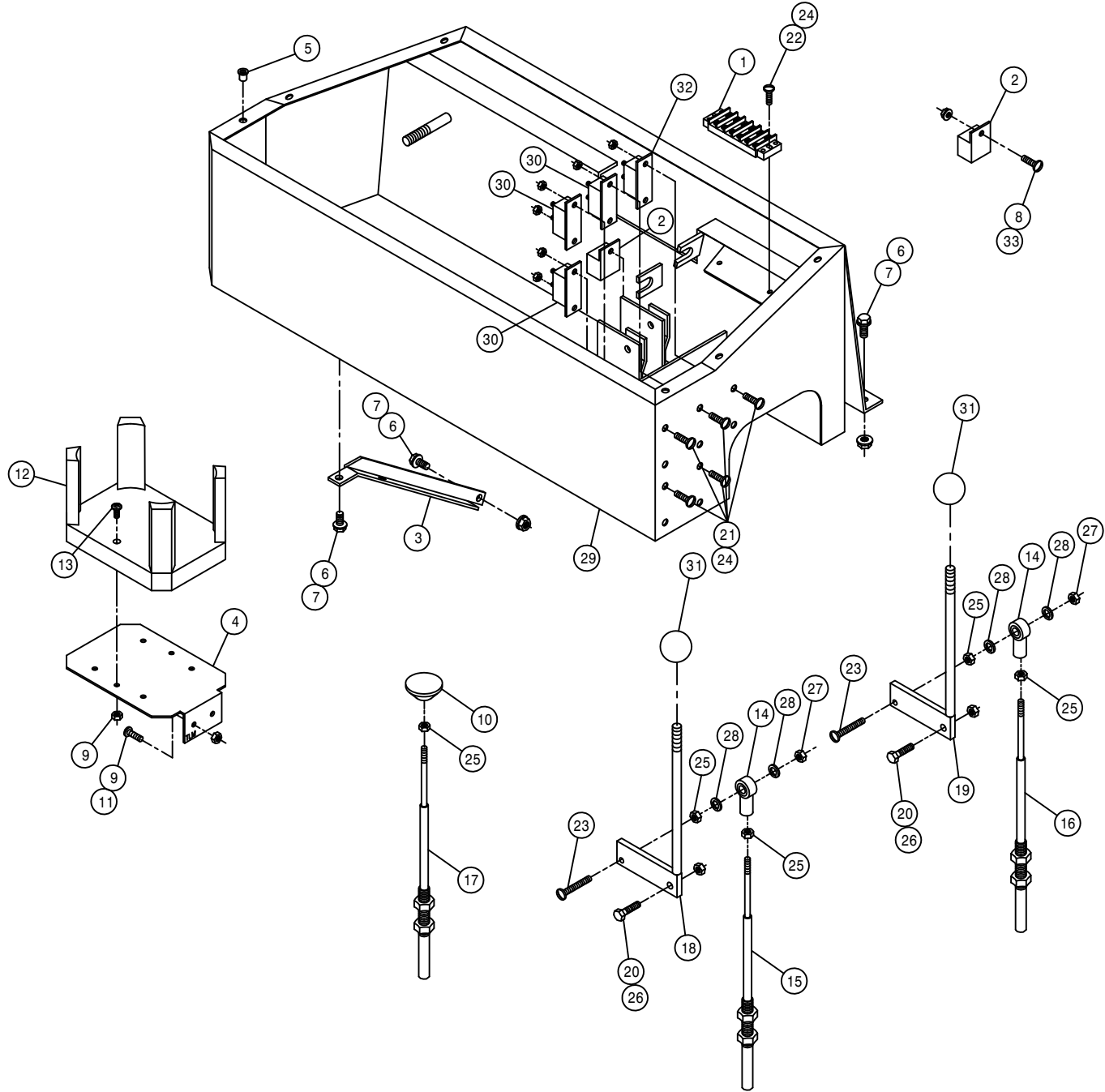

CONSOLE ASSEMBLY

DET.	QTY	PART NO.	DESCRIPTION
1	1	293093	TERMINAL BLOCK 6 POS - 2 ROW
2	2	291640	RELAY, 12V 20/30AMP BOSCH
3	1	342282	CONSOLE BRACE 254/284 95
4	1	342216	DRINK HOLDER MT BRKT 94
5	6	470086	1/4UNC NUTSERT .020-.100MATL
6	5	470118	1/4UNC X 3/4 FLANGE HEX BOLT
7	5	470121	1/4UNC HEX FLANGE LOCK NUT
8	1	903844	8-32 X 1/2 SLT RD HD MACH SCR
9	4	470175	10-32 HEX FLANGE LOCK NUT
10	1	470190	KNOB, 1 3/8" LIFT, BLK 10-32
11	2	903710	10-32X5/8 PHIL PANHD MACH SCR
12	1	470214	SPILLMASTER DRINK HOLDER
13	2	903710	10-32X5/8 PHIL PANHD MACH SCR
14	2	473921	BALL JOINT NO 10-32 THD
15	1	785063	CTRL CABLE 10-32 2IN X 42 LG
16	1	785064	CTRL CABLE 10-32 2IN X 53 LG
17	1	785065	CTRL CABLE 10-32 4IN X 68 LG
18	1	785070	SOLU PRESS CTRL LEVER WLD 94
19	1	785073	AGIT CTRL LEVER WLD 94
20	2	900003	1/4UNC X 1" HEX BOLT
21	9	903812	6-32 X 1/2 SLT RD HD MACH SCR
22	2	903814	6-32 X 3/4 SLT RD HD MACH SCR
23	2	903893	10-32 X 1" SLT RD HD MACH SCR
24	11	910022	6-32 HEX NUT
25	5	910027	10-32 HEX NUT
26	2	914000	1/4UNC HEX STOVER NUT
27	2	914027	10-32 HEX STOVER NUT
28	4	920510	#10 LOCK WASHER
29	1	342191	CONSOLE WLD, 284 CAB 94
30	3	291197	CIRCUIT BREAKER, 30AMP, INLINEMT
31	2	659291	KNOB, 1" RND, BLK, 3/8-16
32	1	291024	CIRCUIT BREAKER, 40AMP, INLINEMT
33	1	910024	8-32 HEX NUT

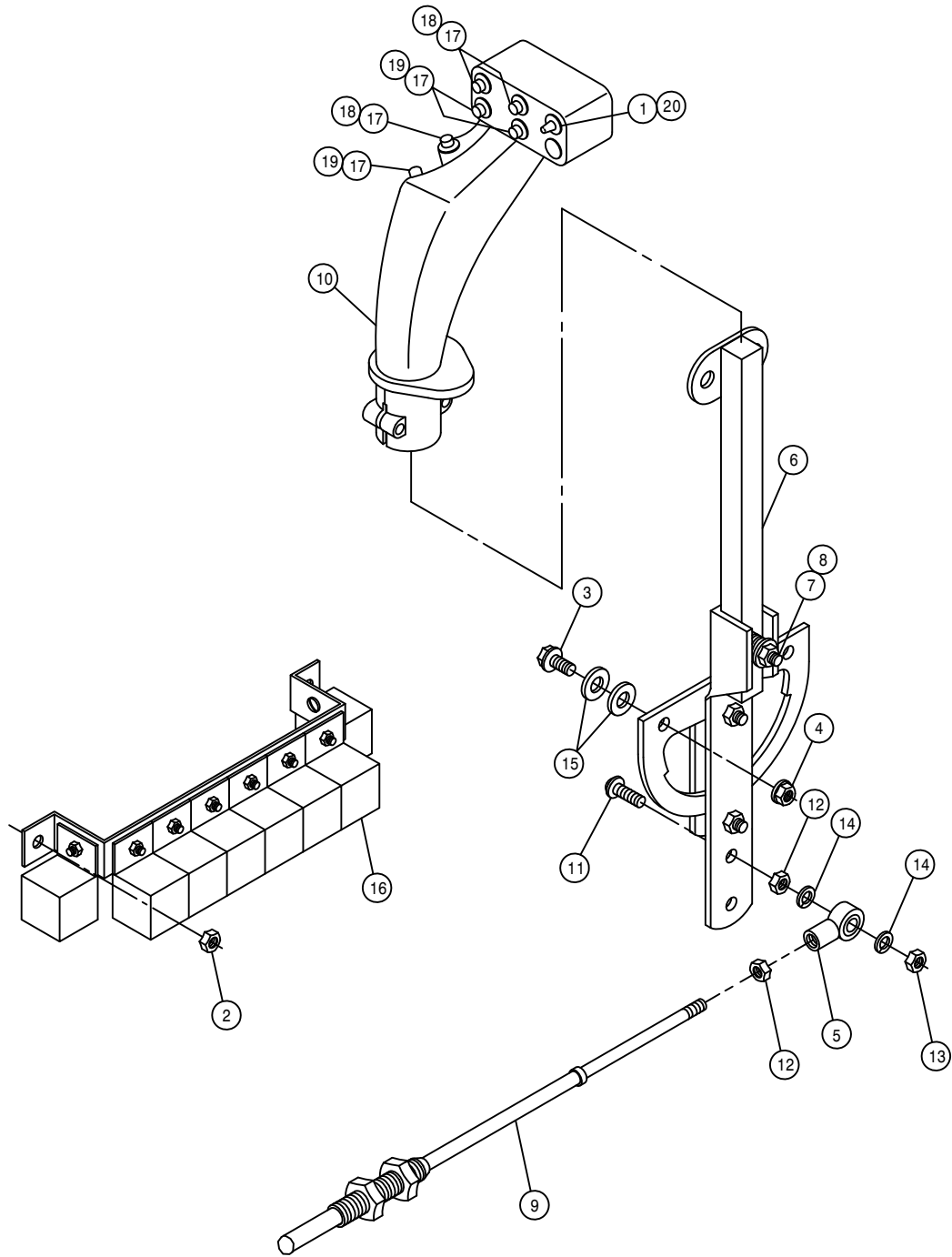

HYDROSTATIC LEVER ASSEMBLY

DET.	QTY	PART NO.	DESCRIPTION
1	1	291653	SWITCH, TOG SPDT 3POS STAT
2	2	470175	10-32 HEX FLANGE LOCK NUT
3	2	470118	1/4UNC X 3/4 FLANGE HEX BOLT
4	2	470121	1/4UNC HEX FLANGE LOCK NUT
5	1	473921	BALL JOINT NO 10-32 THD
6	1	606907	HYDST CTRL LEVER ASSY 204-284
7	1	900005	1/4UNC X 1 1/2 HEX BOLT
8	1	914000	1/4UNC HEX STOVER NUT
9	1	785062	CTRL CABLE 10-32 4IN X 120 LG
10	1	785078	FASSE EZ-3 CTRL HANDLE,284 96
11	1	903893	10-32 X 1" SLT RD HD MACH SCR
12	2	910027	10-32 HEX NUT
13	1	914027	10-32 HEX STOVER NUT
14	2	920510	#10 LOCK WASHER
15	4	920000	1/4 SAE FLAT WASHER
16	6	291640	RELAY, 12V 20/30AMP BOSCH
17	6	291650	SWITCH,SPDT MOM MICRO
18	3	291651	SWITCH BOOT, GRAY -FOR 291650
19	3	291652	SWITCH BOOT, RED -FOR 291650
20	1	291654	SWITCH BOOT, BLACK-FOR 291653

THROTTLE LEVER ASSEMBLY

DET. QTY PART NO. DESCRIPTION

1	1	499001	SPRING HYDRO CONTROL
2	1	785007	KNOB, 1 3/16" BALL, RED, 3/8-16
3	1	785046	FRICTION DISC 3-333 X .38
4	1	785066	CTRL CABLE 10-32 4IN X 129 IN
5	1	785067	THROT LEVER WLD,GAS/DIESEL 94
6	1	903893	10-32 X 1" SLT RD HD MACH SCR
7	2	910027	10-32 HEX NUT
8	1	914004	3/8UNC HEX STOVER NUT
9	1	914027	10-32 HEX STOVER NUT
10	1	920002	3/8 SAE FLAT WASHER
11	2	920510	#10 LOCK WASHER
12	1	473921	BALL JOINT NO 10-32 THD

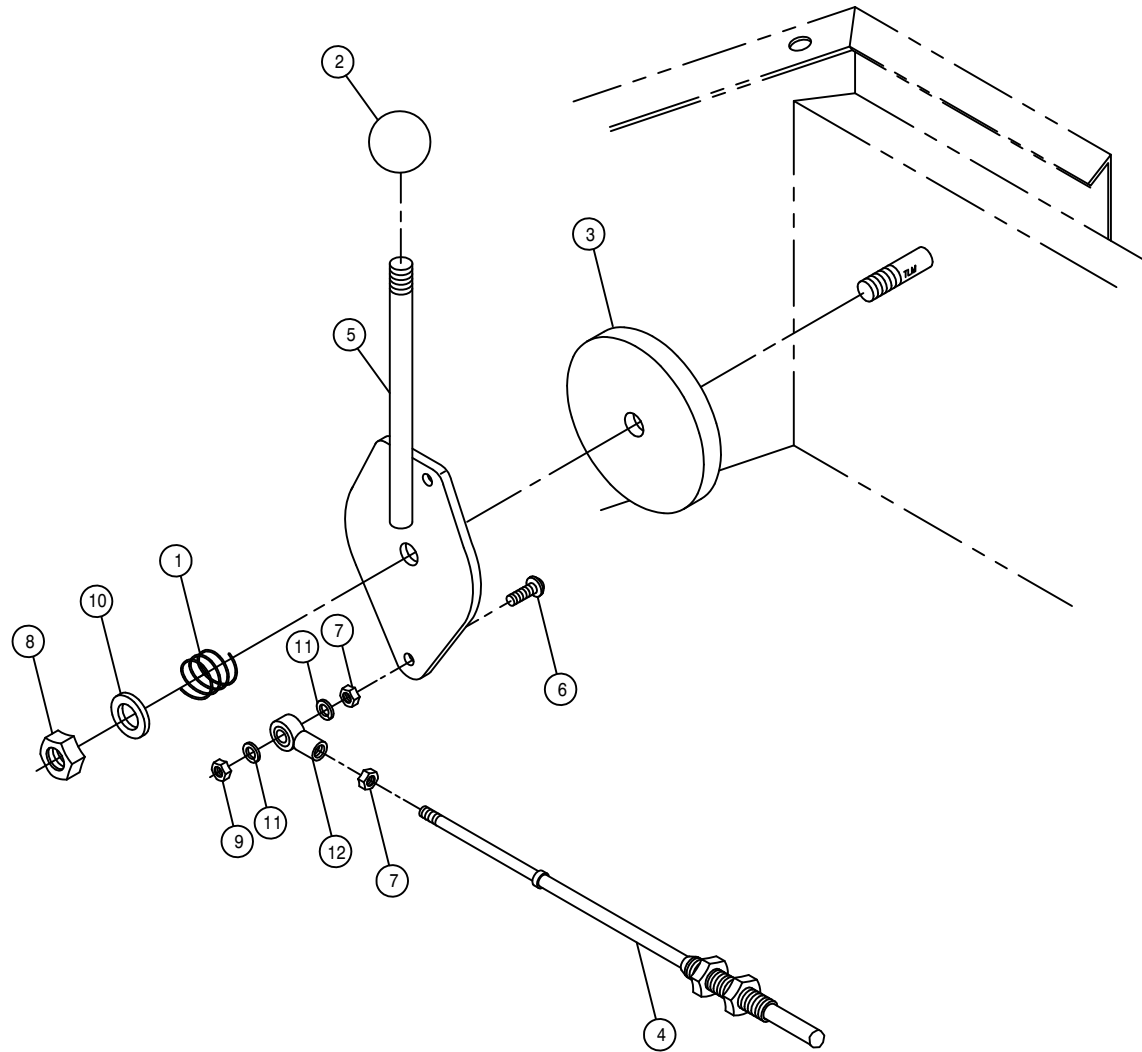

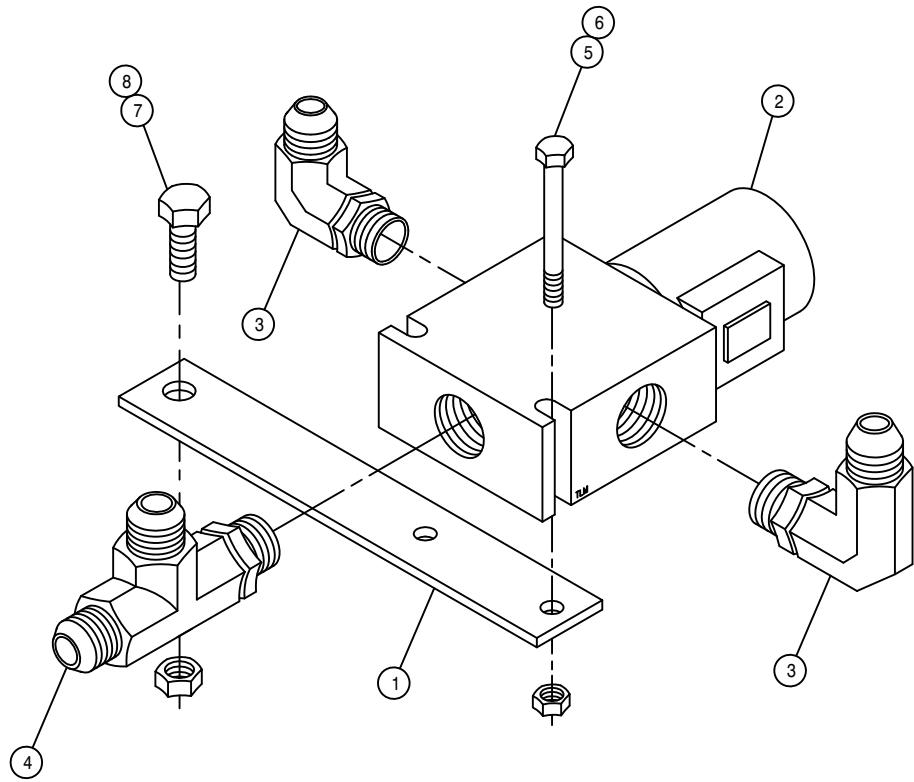

BRAKE SOLENOID ASSEMBLY

DET. QTY PART NO. DESCRIPTION

1	1	342332	PARK BRAKE SOL VLV MT	97
2	1	610318	HYD SOLE VLV, 2P-3W, 9/16FOR, 12V	
3	2	618119	9/16MJIC-90-9/16MOR LBO	
4	1	618444	9/16MOR RUN TEE-9/16MJIC	
5	2	900006	1/4UNC X 1 3/4 HEX BOLT	
6	2	914000	1/4UNC HEX STOVER NUT	
7	1	900129	3/8UNC X 1" HEX BOLT	
8	1	914004	3/8UNC HEX STOVER NUT	

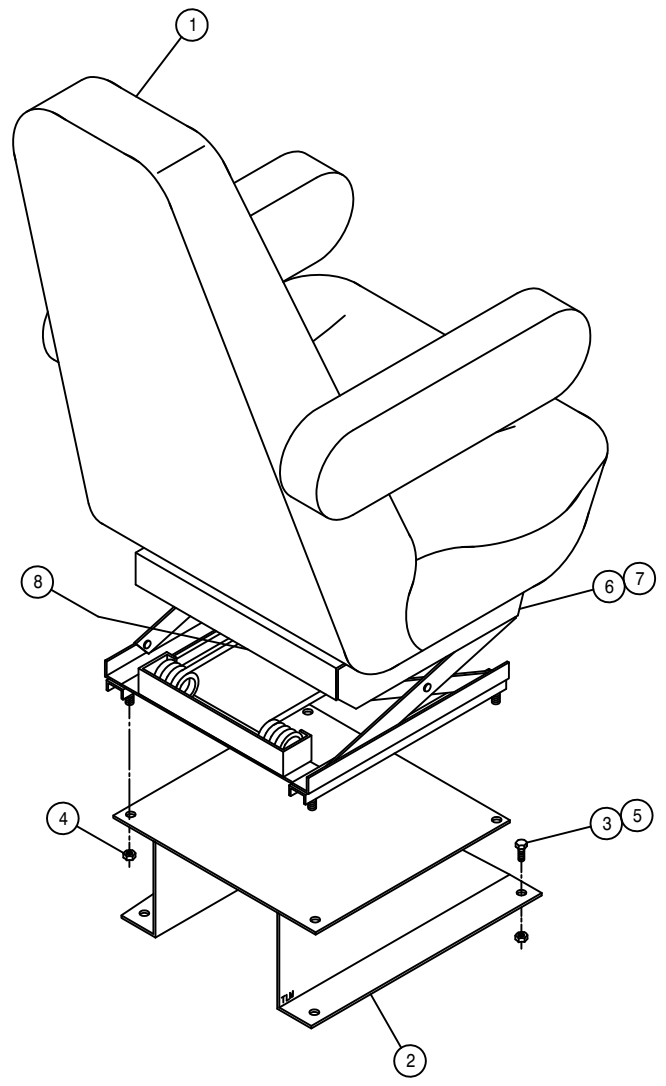

SEAT ASSEMBLY

DET.	QTY	PART NO.	DESCRIPTION
1	1	330022	SEAT, MAGNUM-100 AIR SUSPEND95
2	1	342090	SEAT MT WELD, 254/284 95
3	4	900129	3/8UNC X 1" HEX BOLT
4	4	914002	5/16UNC HEX STOVER NUT
5	4	914004	3/8UNC HEX STOVER NUT
6	1	330024	HEIGHT ADJ LATCH, SEAT 330022
7	1	330025	ADJ LATCH SPRING, SEAT 330022
8	1	330023	AIR BAG PKG, SEAT 330022

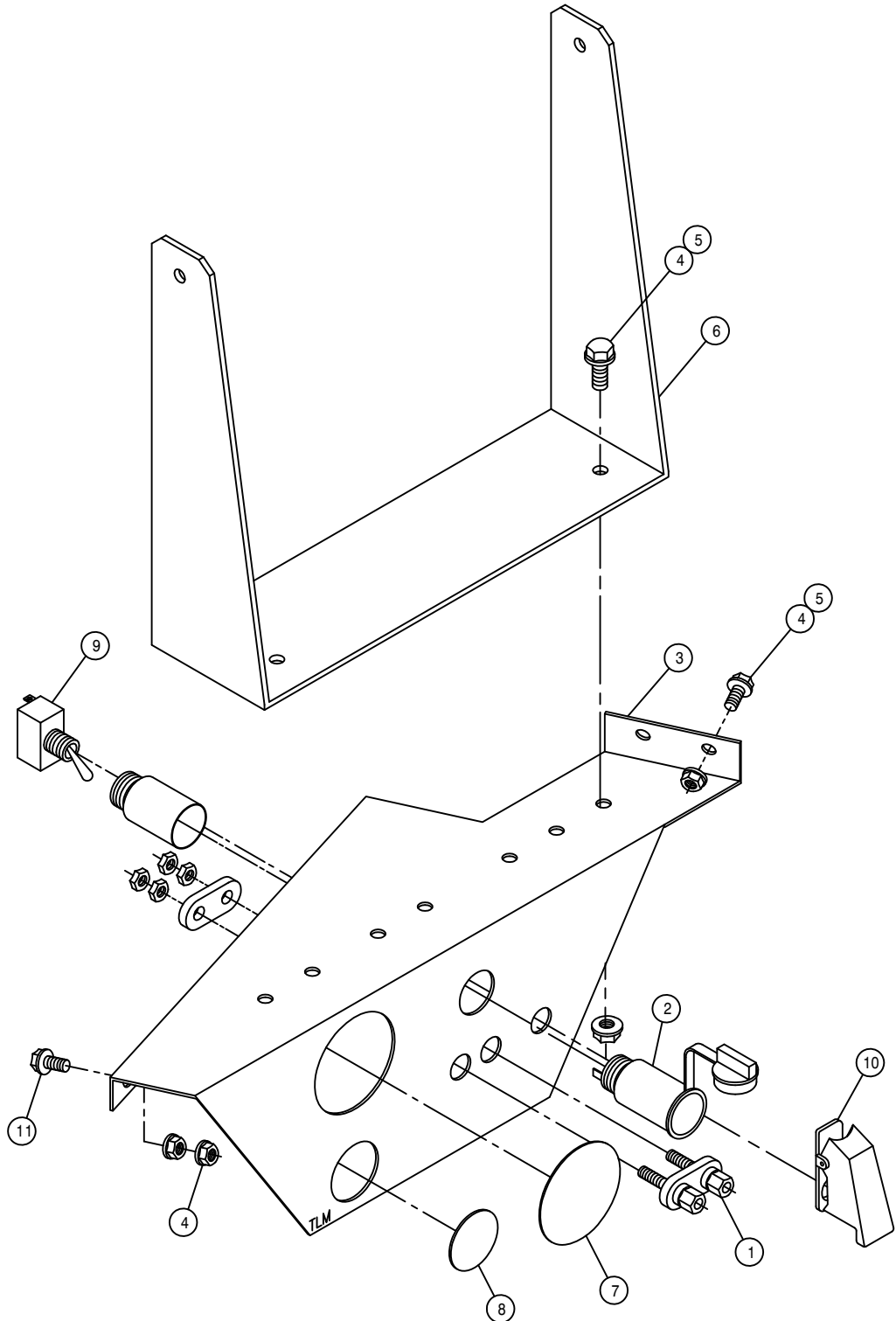

MONITOR MOUNTING BRACKET ASSEMBLY

DET.	QTY	PART NO.	DESCRIPTION	
1	1	291647	DUAL BINDING POSTS	
2	1	291648	POWER POINT RECEPTACLE	
3	1	342215	MONITOR MT, 284 CAB	94
4	7	470121	1/4UNC HEX FLANGE LOCK NUT	
5	5	470122	1/4UNC X 1/2 FLANGE HEX BOLT	
6	1	690498	CONSOLE MT, RAVEN 460	95
7	1	629728	FINISH PLUG FOR 2.12 HOLE	
8	1	629730	FINISH PLUG FOR 1.25 HOLE	
9	1	298012	TOGGLE SWITCH	
10	1	291655	AIRCRAFT TOGGLE SWITCH GUARD	
11	1	470118	1/4UNC X 3/4 FLANGE HEX BOLT	

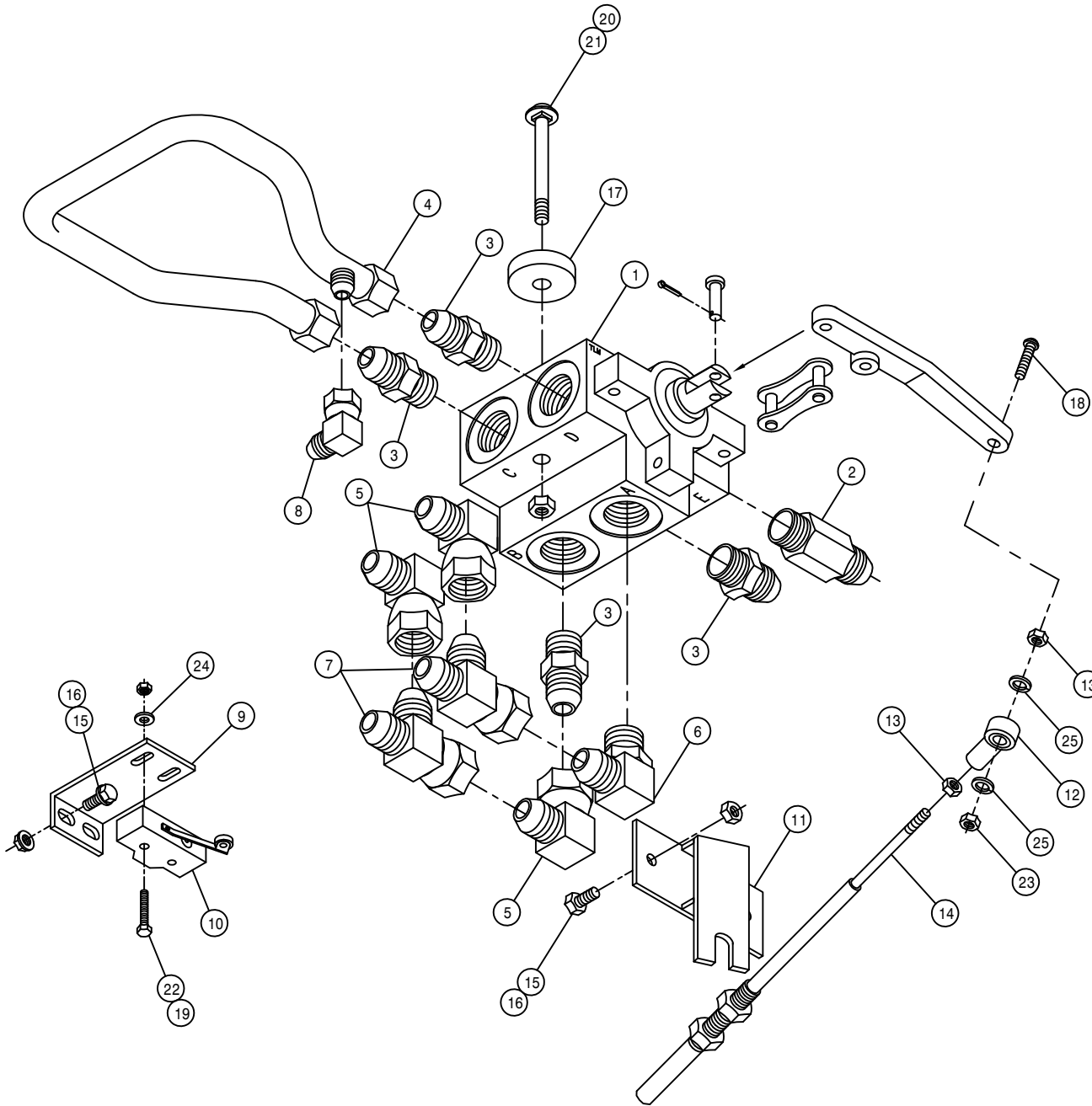

FOUR-WHEEL DRIVE SELECTOR VALVE ASSEMBLY

DET. QTY PART NO. DESCRIPTION

1	1	606003	GRESEN SELECTOR VALVE DS-12
2	1	607527	FLOW CTRL VALVE,32GPM IN-LINE
3	4	611127	1 1/16MJIC-1 1/16MOR ADPTR
4	1	614290	FWD UTUBE 472 P/C 1977 18WHMT
5	3	618191	1 1/16MJ-90-1 1/16FJ SWIV LBO
6	1	618248	1 1/16MJIC-90-1 1/16MOR LBO
7	2	618487	1 1/16FJ SW RUN TEE-1 1/16MJ
8	1	618618	9/16MJIC-90-9/16FJIC SWIV LBO
9	1	291646	TRACT VLV MICRO SWITCH MT
10	1	293006	MICRO SWITCH #BZ-2RL25551-A2
11	1	341861	FWD CABLE MT WLD 280 89
12	1	473921	BALL JOINT NO 10-32 THD
13	2	910027	10-32 HEX NUT
14	1	785065	CTRL CABLE 10-32 4IN X 68 LG
15	4	470118	1/4UNC X 3/4 FLANGE HEX BOLT
16	4	470121	1/4UNC HEX FLANGE LOCK NUT
17	2	748501	RUBBER WASH .38 X .406 X 1.50
18	1	903893	10-32 X 1" SLT RD HD MACH SCR
19	2	910022	6-32 HEX NUT
20	2	914004	3/8UNC HEX STOVER NUT
21	2	901136	3/8UNC X 3" CARR BOLT
22	2	473993	6-32 X 1 1/8 HH MACH SCR
23	1	914027	10-32 HEX STOVER NUT
24	2	920011	# 6 SAE FLAT WASHER
25	2	920510	#10 LOCK WASHER

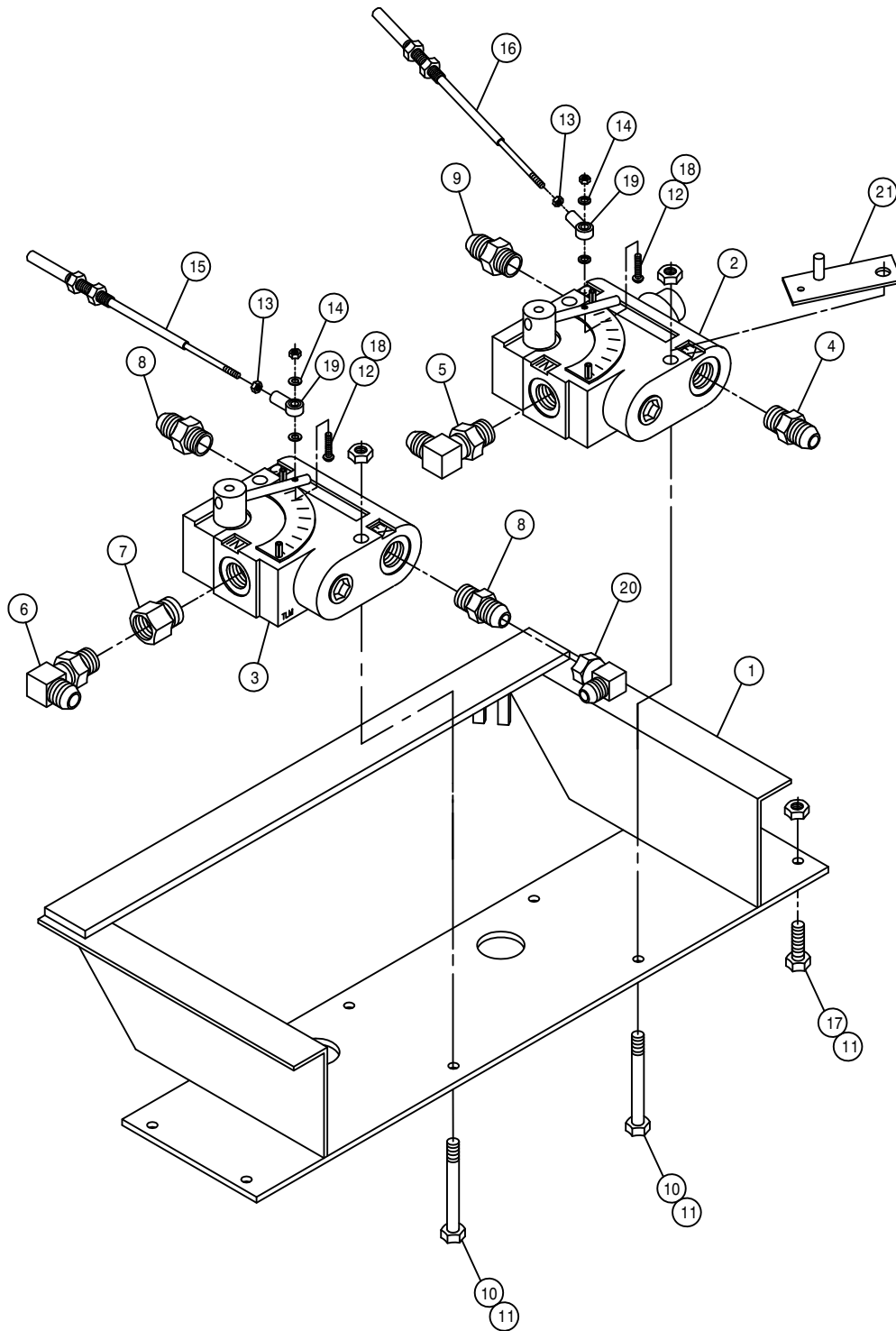

VARIABLE FLOW CONTROL ASSEMBLY

DET.	QTY	PART NO.	DESCRIPTION	
	1	342209	SOLU VFC MT WLD	94
	2	606818	FLO CONT FCR51 0-16GPM 7/8FOR	
	3	606827	FLO CONT FC51 0-3 VARI 7/8FOR	
	4	611126	7/8MJIC-7/8MOR ADPTR	
	5	611128	7/8MJIC-90-7/8MOR LBO	
	6	618119	9/16MJIC-90-9/16MOR LBO	
	7	618172	7/8MOR-9/16FOR ADPTR	
	8	618310	9/16MJIC-7/8MOR ADPTR	
	9	618327	3/4MJIC-7/8MOR ADPTR	
	10	900008	1/4UNC X 2 1/2 HEX BOLT	
	11	914000	1/4UNC HEX STOVER NUT	
	12	903893	10-32 X 1" SLT RD HD MACH SCR	
	13	910027	10-32 HEX NUT	
	14	920510	#10 LOCK WASHER	
	15	785064	CTRL CABLE 10-32 2IN X 53 LG	
	16	785063	CTRL CABLE 10-32 2IN X 42 LG	
	17	470118	1/4UNC X 3/4 FLANGE HEX BOLT	
	18	914027	10-32 HEX STOVER NUT	
	19	473921	BALL JOINT NO 10-32 THD	
	20	618618	9/16MJIC-90-9/16FJIC SWIV LBO	
	21	342306	SOLU PUMP VFC STOP WLD,9G	96

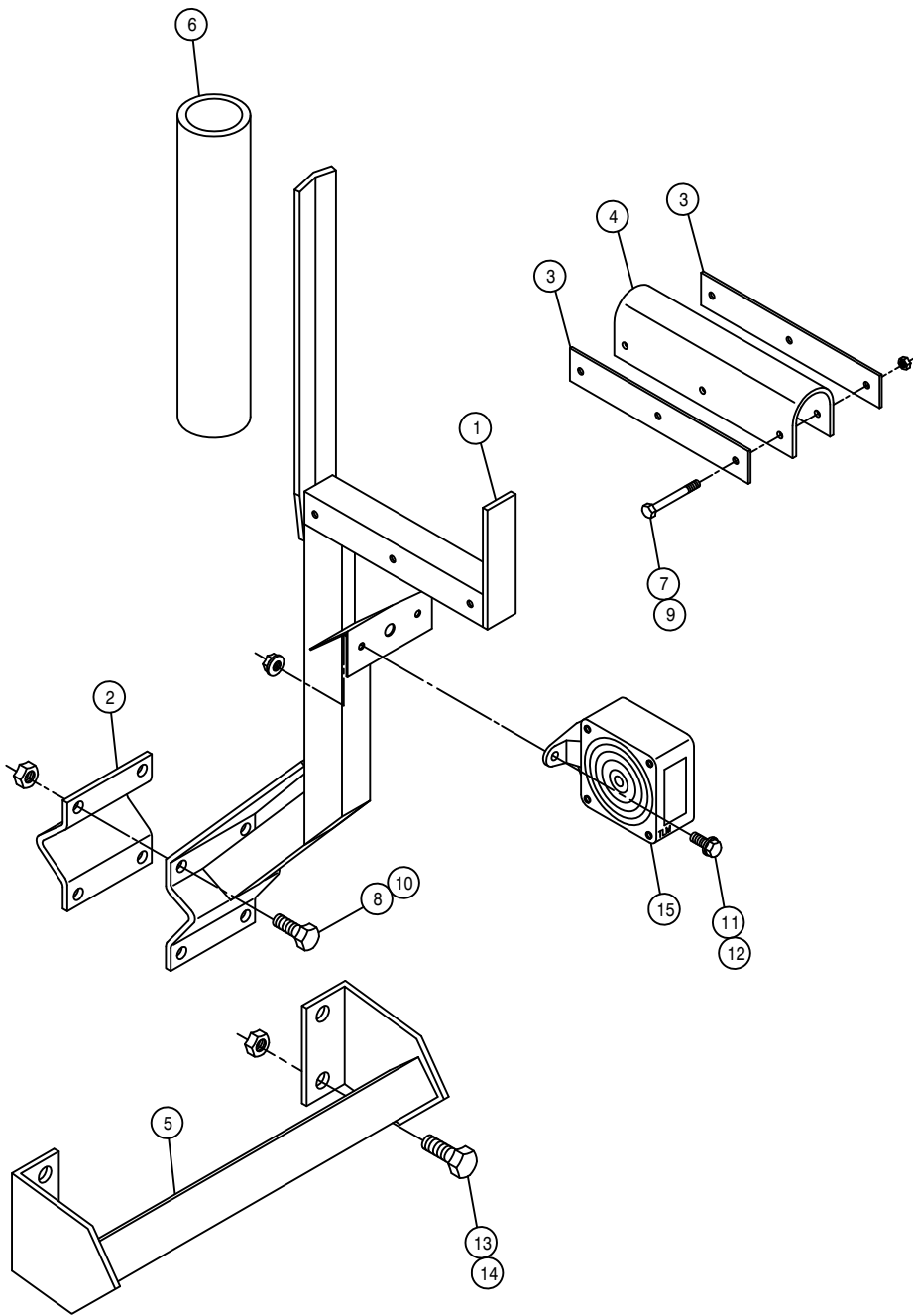

BOOM CRADLE ASSEMBLY

DET. QTY PART NO. DESCRIPTION

1	2	164245	BOOM CRADLE WLD	96
2	2	164253	BOOM CRADLE V-PLATE KEEPER	96
3	4	164254	CRADLE CUSHION KEEPER	96
4	2	164256	BOOM CRADLE CUSHION	96
5	2	164258	BOOM CRADLE MT WLD	96
6	2	601184	HOSE, 1 1/2 X 14 2BR BLK EPDM	
7	6	900008	1/4UNC X 2 1/2 HEX BOLT	
8	8	900265	1/2UNC X 1 1/2 HEX BOLT	
9	6	914000	1/4UNC HEX STOVER NUT	
10	8	914008	1/2UNC HEX STOVER NUT	
11	4	470121	1/4UNC HEX FLANGE LOCK NUT	
12	4	470118	1/4UNC X 3/4 FLANGE HEX BOLT	
13	8	900334	5/8UNC X 1 3/4 HEX BOLT	
14	8	914010	5/8UNC HEX STOVER NUT	
15	2	291604	TURN SIGNAL LIGHT,PED MT, YEL	

NOTE: QUANTITY LISTED IS FOR ONE MACHINE.

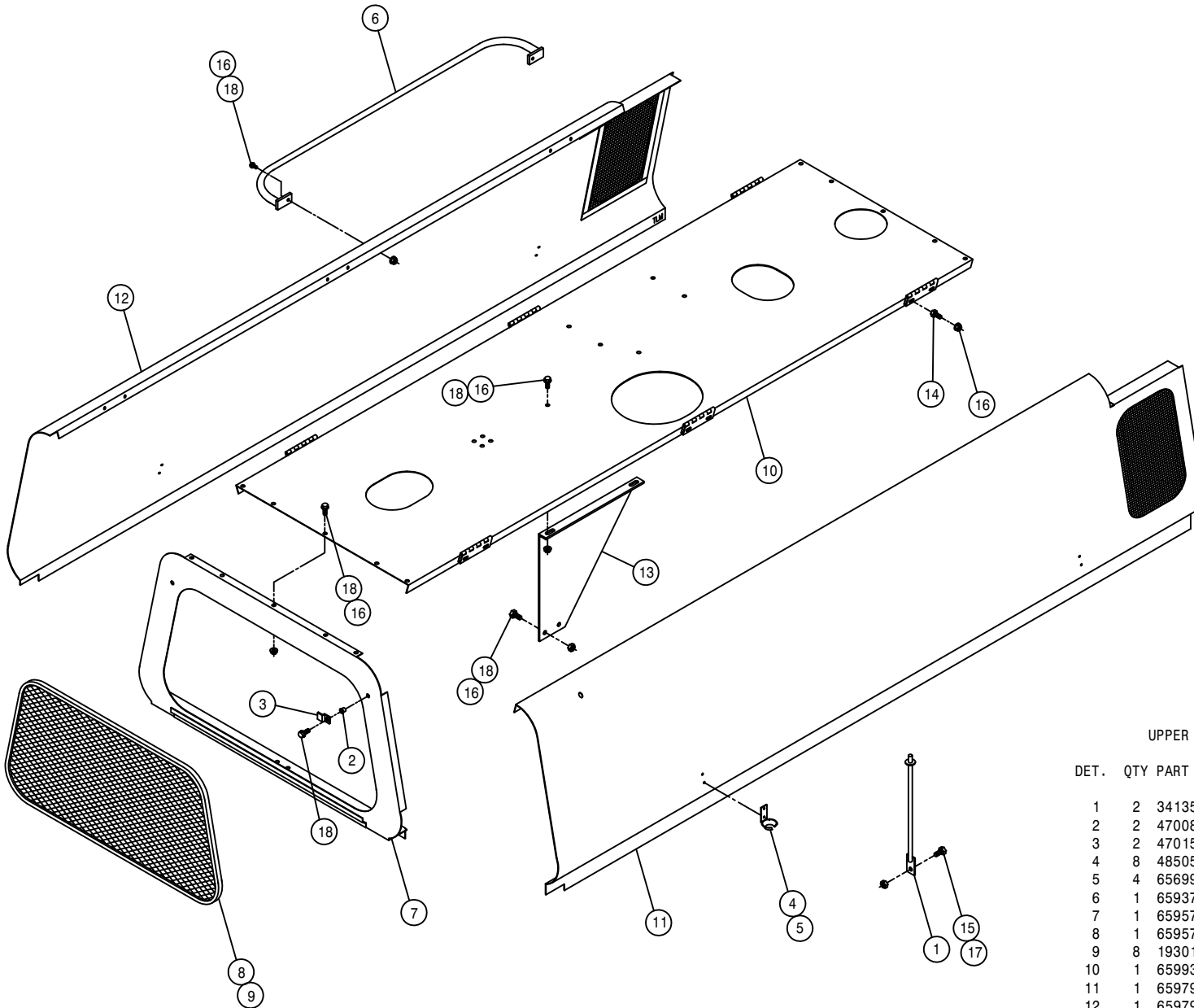

UPPER SHEET METAL ASSEMBLY

DET. QTY PART NO. DESCRIPTION

1	2	341356	ENGINE HOOD PROP WLD 8240	82
2	2	470086	1/4UNC NUTSERT .020-.100MATL	
3	2	470151	UPPER REAR PANEL SCREEN CLIP	
4	8	485053	POP RIVET 3/16 X 3/8	
5	4	656997	RUBBER HOOK BRKT 473	
6	1	659378	RH ENG HOOD HANDRAIL WLD 647S	
7	1	659575	UPPER REAR PANEL WLD 8240	82
8	1	659578	UPPER REAR PANEL SCREEN 8240	
9	8	193016	QUICKEDGE TRIM .060 TO .170	
10	1	659931	MULLION WLD, 204 CUMM	97
11	1	659796	RH ENGINE HOOD WLD 280	89
12	1	659797	LH ENGINE HOOD WLD 280	89
13	1	659930	MULLION SUPPORT BRKT, 284	97
14	12	900000	1/4UNC X 1/2 HEX BOLT	
15	2	900128	3/8UNC X 3/4 HEX BOLT	
16	28	470121	1/4UNC HEX FLANGE LOCK NUT	
17	2	914004	3/8UNC HEX STOVER NUT	
18	18	470118	1/4UNC X 3/4 FLANGE HEX BOLT	

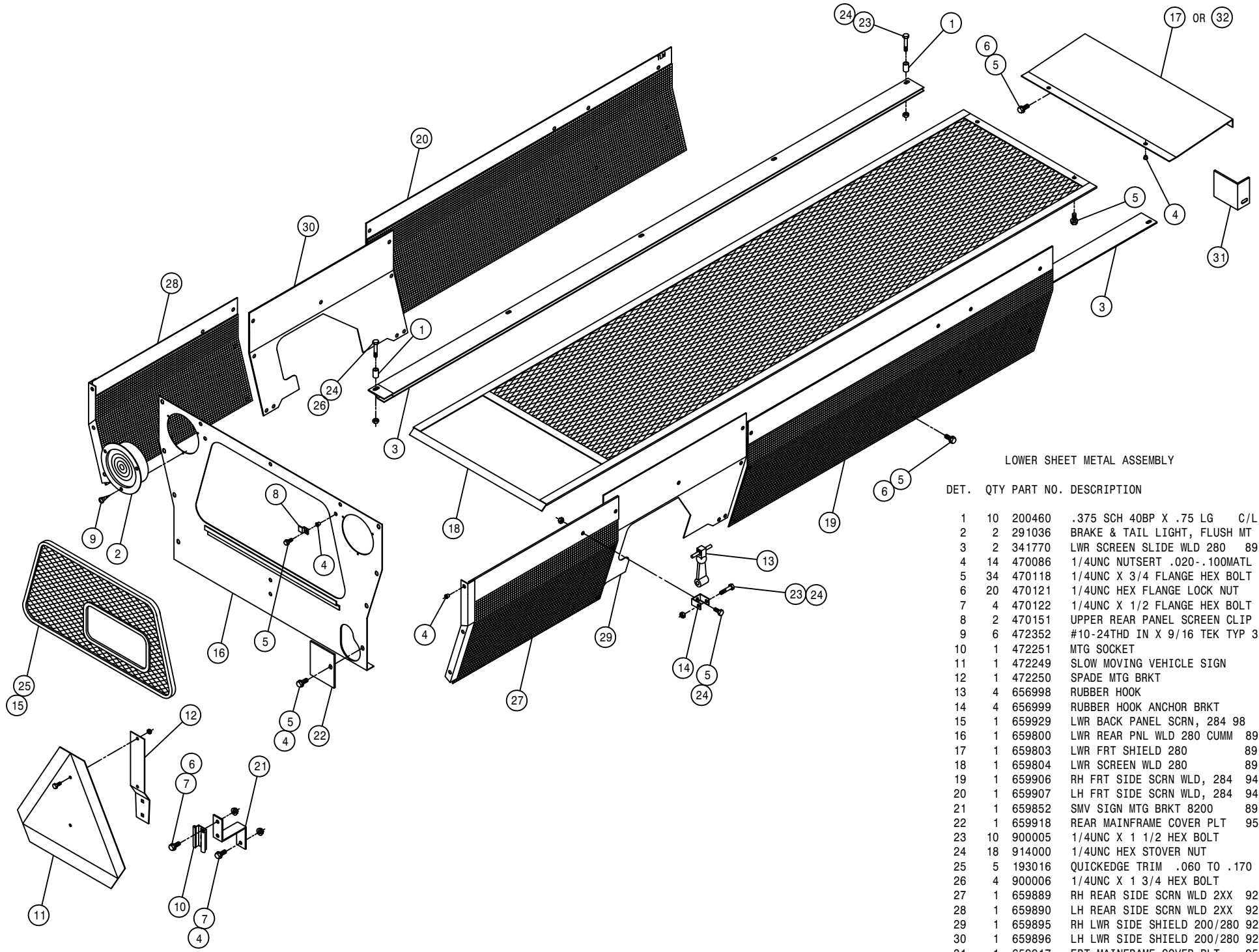

LOWER SHEET METAL ASSEMBLY

DET.	QTY	PART NO.	DESCRIPTION
1	10	200460	.375 SCH 40BP X .75 LG C/L
2	2	291036	BRAKE & TAIL LIGHT, FLUSH MT
3	2	341770	LWR SCREEN SLIDE WLD 280 89
4	14	470086	1/4UNC NUTSERT .020-.100MATL
5	34	470118	1/4UNC X 3/4 FLANGE HEX BOLT
6	20	470121	1/4UNC HEX FLANGE LOCK NUT
7	4	470122	1/4UNC X 1/2 FLANGE HEX BOLT
8	2	470151	UPPER REAR PANEL SCREEN CLIP
9	6	472352	#10-24THD IN X 9/16 TEK TYP 3
10	1	472251	MTG SOCKET
11	1	472249	SLOW MOVING VEHICLE SIGN
12	1	472250	SPADE MTG BRKT
13	4	656998	RUBBER HOOK
14	4	656999	RUBBER HOOK ANCHOR BRKT
15	1	659929	LWR BACK PANEL SCRNL, 284 98
16	1	659800	LWR REAR PNL WLD 280 CUMM 89
17	1	659803	LWR FRT SHIELD 280 89
18	1	659804	LWR SCREEN WLD 280 89
19	1	659906	RH FRT SIDE SCRNL WLD, 284 94
20	1	659907	LH FRT SIDE SCRNL WLD, 284 94
21	1	659852	SMV SIGN MTG BRKT 8200 89
22	1	659918	REAR MAINFRAME COVER PLT 95
23	10	900005	1/4UNC X 1 1/2 HEX BOLT
24	18	914000	1/4UNC HEX STOVER NUT
25	5	193016	QUICKEDGE TRIM .060 TO .170
26	4	900006	1/4UNC X 1 3/4 HEX BOLT
27	1	659889	RH REAR SIDE SCRNL WLD 2XX 92
28	1	659890	LH REAR SIDE SCRNL WLD 2XX 92
29	1	659895	RH LWR SIDE SHIELD 200/280 92
30	1	659896	LH LWR SIDE SHIELD 200/280 92
31	1	659917	FRT MAINFRAME COVER PLT 95
32	1	659908	LWR FRT SHIELD, 284 COMBO 94

FRONT TANK MOUNTS AND SHIELDS

DET. QTY PART NO. DESCRIPTION

1	1	659831	LWR FRONT SHIELD 280	89
2	2	763453	TANK SUPPORT ARM, 284T	94
3	1	763447	RH FRT SOLU TANK MT WLD284	94
4	1	763448	LH FRT SOLU TANK MT WLD284	94
5	4	900006	1/4UNC X 1 3/4 HEX BOLT	
6	4	900333	5/8UNC X 1 1/2 HEX BOLT	
7	2	900416	3/4UNC X 6 1/2 HEX BOLT	
8	8	920002	3/8 SAE FLAT WASHER	
9	4	914010	5/8UNC HEX STOVER NUT	
10	2	914012	3/4UNC HEX STOVER NUT	
11	4	920006	3/4 SAE FLAT WASHER	
12	4	914004	3/8UNC HEX STOVER NUT	
13	4	160621	SPRING TIGHTENER HOOK BUSH	
14	20	470118	1/4UNC X 3/4 FLANGE HEX BOLT	
15	24	470121	1/4UNC HEX FLANGE LOCK NUT	
16	1	659856	RH FRT POLY TANK SHLD WLD 280	
17	1	659857	LH FRT POLY TANK SHLD WLD 280	
18	4	659834	FRT LEG SHIELD MTG BRKT280	89
19	1	659854	RH FRT SS TANK SHIELD 280	90
20	1	659855	LH FRT SS TANK SHIELD 280	90
21	4	900130	3/8UNC X 1 1/4 HEX BOLT	
22	8	920000	1/4 SAE FLAT WASHER	

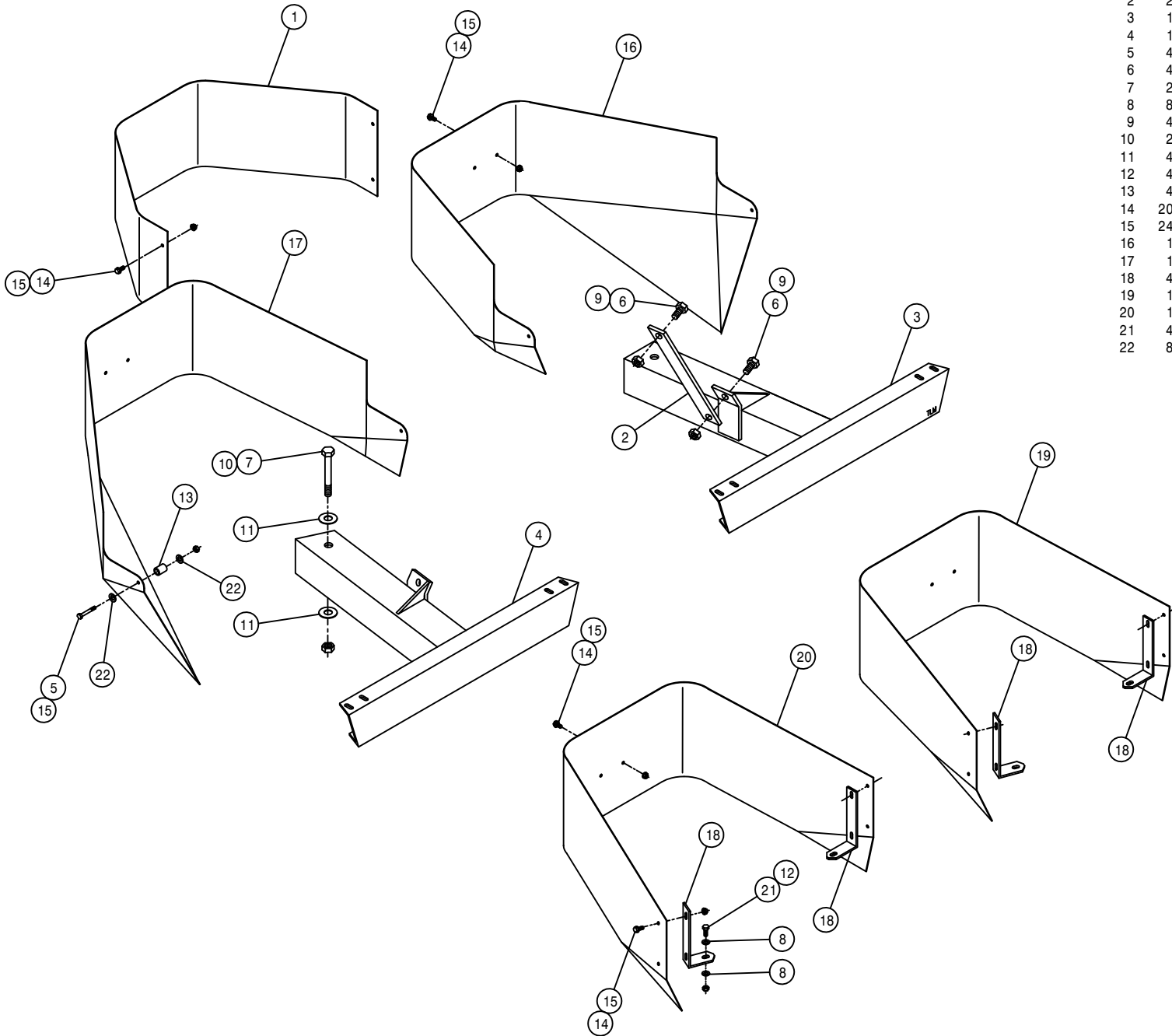

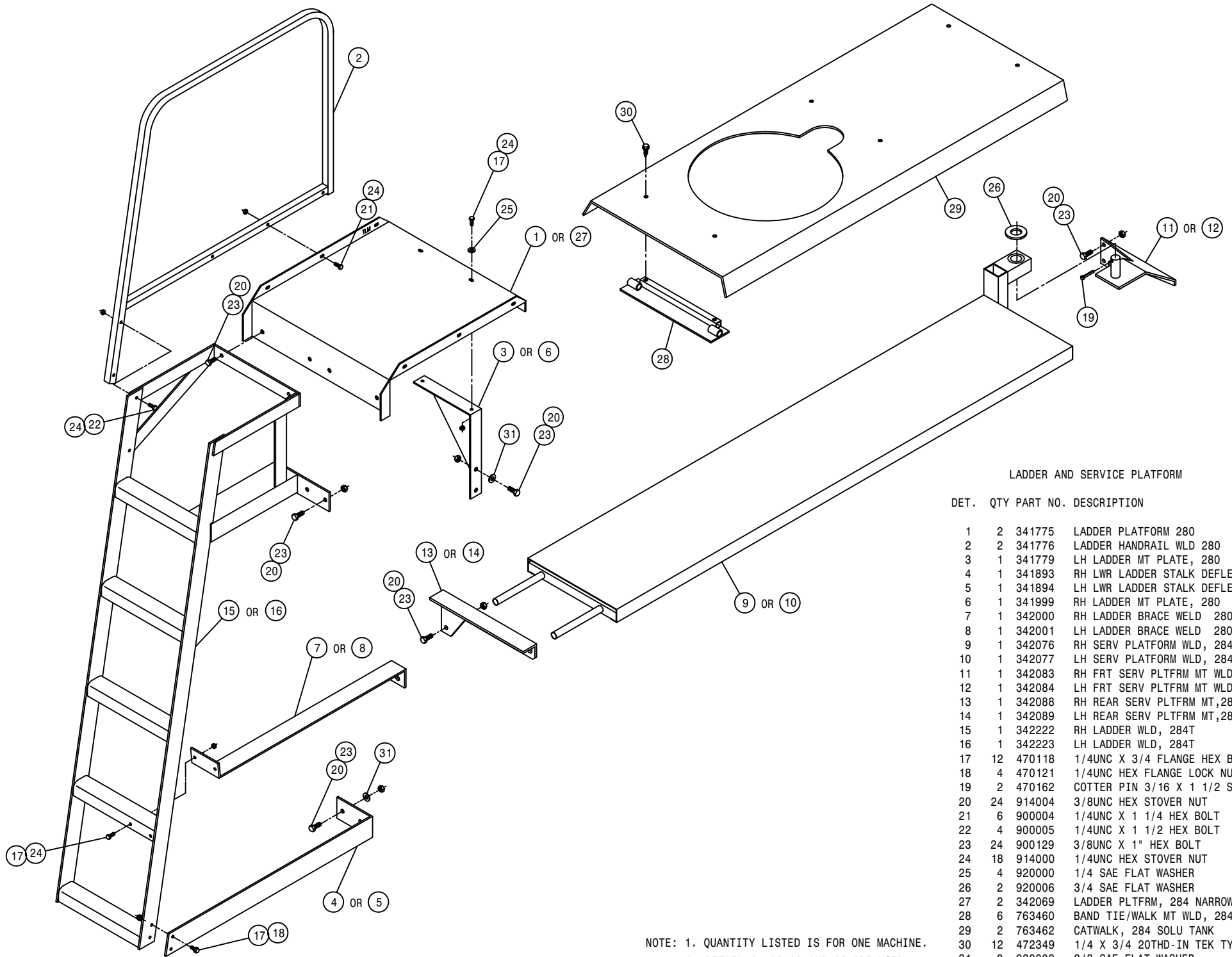

LADDER AND SERVICE PLATFORM

DET.	QTY	PART NO.	DESCRIPTION		
	1	2	341775	LADDER PLATFORM 280	89
	2	2	341776	LADDER HANDRAIL WLD 280	89
	3	1	341779	LH LADDER MT PLATE, 280	89
	4	1	341893	RH LWR LADDER STALK DEFLEC280	
	5	1	341894	LH LWR LADDER STALK DEFLEC280	
	6	1	341999	RH LADDER MT PLATE, 280	89
	7	1	342000	RH LADDER BRACE WELD 280	92
	8	1	342001	LH LADDER BRACE WELD 280	92
	9	1	342076	RH SERV PLATFORM WLD, 284	95
	10	1	342077	LH SERV PLATFORM WLD, 284	95
	11	1	342083	RH FRT SERV PLTFRM MT WLD 95	
	12	1	342084	LH FRT SERV PLTFRM MT WLD 95	
	13	1	342088	RH REAR SERV PLTFRM MT,284	95
	14	1	342089	LH REAR SERV PLTFRM MT,284	95
	15	1	342222	RH LADDER WLD, 284T	94
	16	1	342223	LH LADDER WLD, 284T	94
	17	12	470118	1/4UNC X 3/4 FLANGE HEX BOLT	
	18	4	470121	1/4UNC HEX FLANGE LOCK NUT	
	19	2	470162	COTTER PIN 3/16 X 1 1/2 SQCUT	
	20	24	914004	3/8UNC HEX STOVER NUT	
	21	6	900004	1/4UNC X 1 1/4 HEX BOLT	
	22	4	900005	1/4UNC X 1 1/2 HEX BOLT	
	23	24	900129	3/8UNC X 1" HEX BOLT	
	24	18	914000	1/4UNC HEX STOVER NUT	
	25	4	920000	1/4 SAE FLAT WASHER	
	26	2	920006	3/4 SAE FLAT WASHER	
	27	2	342069	LADDER PLTFRM, 284 NARROW	94
	28	6	763460	BAND TIE/WALK MT WLD, 284	95
	29	2	763462	CATWALK, 284 SOLU TANK	95
	30	12	472349	1/4 X 3/4 20THD-IN TEK TYPE	
	31	8	920002	3/8 SAE FLAT WASHER	

NOTE: 1. QUANTITY LISTED IS FOR ONE MACHINE.
 2. DETAIL 27,28,29 AND 30 ARE USED WITH THE NARROW TREAD OPTION.

ELECTRIC BOOM VALVE ASSEMBLY

DET. QTY PART NO. DESCRIPTION

1	15	473821	#10 INT TOOTH WASHER
2	15	910027	10-32 HEX NUT
3	1	610447	HYD FILTER, INLINE 1/4FNPT 90M
4	1	610569	6 SECT, 5 FUNCTN HYD VLV, EATON
5	1	611121	9/16MJIC-1/4MNPT ADPTR
6	11	618119	9/16MJIC-90-9/16MOR LBO
7	4	618126	9/16MJIC-9/16MOR ADPTR
8	1	618440	9/16MJIC-90-9/16MOR EX LG LBO
9	4	618514	9/16FJ SW BRANCH TEE-9/16MJ
10	1	618562	9/16MOR-90-1/4MNPT LBO
11	2	610574	VALVE SECTION ASSY FOR 610569
12	2	610575	SOLENOID COIL ASSY FOR 610569
13	2	610576	SOLENOID CASE FOR 610569
14	2	610577	SOLENOID CASE NUT FOR 610569
15	8	610578	SECTION O-RING FOR 610569
16	4	610579	7-SECTION TIE STUD FOR 610569
17	4	470118	1/4UNC X 3/4 FLANGE HEX BOLT
18	4	470121	1/4UNC HEX FLANGE LOCK NUT
19	1	610459	90M FILTER & GASKET FOR 610447
20	1	610462	GASKET FOR 610447 ARROW FILT
21	2	618486	9/16FJIC SW RUN TEE-9/16MJIC
22	2	618618	9/16MJIC-90-9/16FJIC SWIV LBO
23	4	610598	8-SECTION TIE STUD FOR 610569

NOTE: 610584 - VALVE SECTION KIT INCLUDES ONE OF
DETAIL 11, 12, 13, 14, AND FOUR OF DETAIL 15.

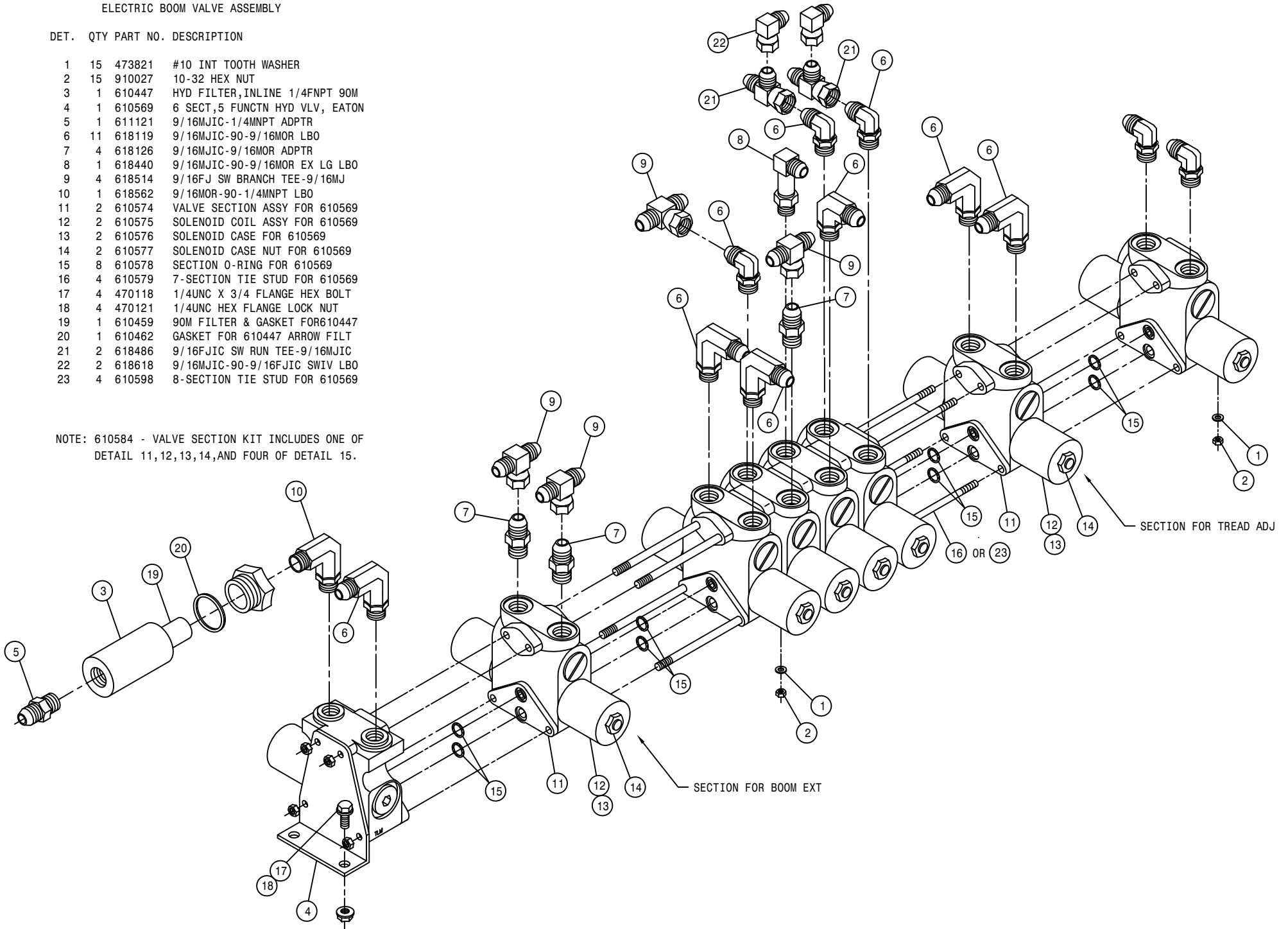

LIFTARM ASSEMBLY

DET. QTY PART NO. DESCRIPTION

DET.	QTY	PART NO.	DESCRIPTION
1	2	160471	LWR LIFT ARM WLD 8540-8250 87
2	1	160495	RH LIFT ARM MT WLD 280 89
3	1	160496	LH LIFT ARM MT WLD 280 89
4	12	160691	BUSH LIFT ARM LONG 470
5	12	470287	TUBE CLAMP, .375-.375 (PAIR)
6	1	164297	UPPER LIFT ARM WLD, 284 97
7	12	471005	1/4 28 X 1/2 GREASE ZERK
8	3	900023	1/4UNC X 2 1/4 HEX BOLT
9	2	620700	LIFT CYL ASSY,2.50 W/FTGS 99
10	6	900004	1/4UNC X 1 1/4 HEX BOLT
11	6	900333	5/8UNC X 1 1/2 HEX BOLT
12	4	900342	5/8UNC X 4" HEX BOLT
13	8	900343	5/8UNC X 4 1/2 HEX BOLT
14	18	914010	5/8UNC HEX STOVER NUT
15	1	615637	LIFT HYD TUBE ASSY,UP 254/284
16	1	615638	LIFT HYD TUBE ASSY,DN 254/284
17	1	615639	LEVEL HYD TUBE ASSY,UP254/284
18	1	615640	LEVEL HYD TUBE ASSY,DN254/284
19	1	615641	FOLD HYD TUBE ASSY,IN 254/284
20	1	615642	FOLD HYD TUBE ASSY,OUT254/284
21	9	914000	1/4UNC HEX STOVER NUT
22	1	615683	FOLD BOOM HYD TUBE ASSY, OUT
23	1	615682	FOLD BOOM HYD TUBE ASSY, IN

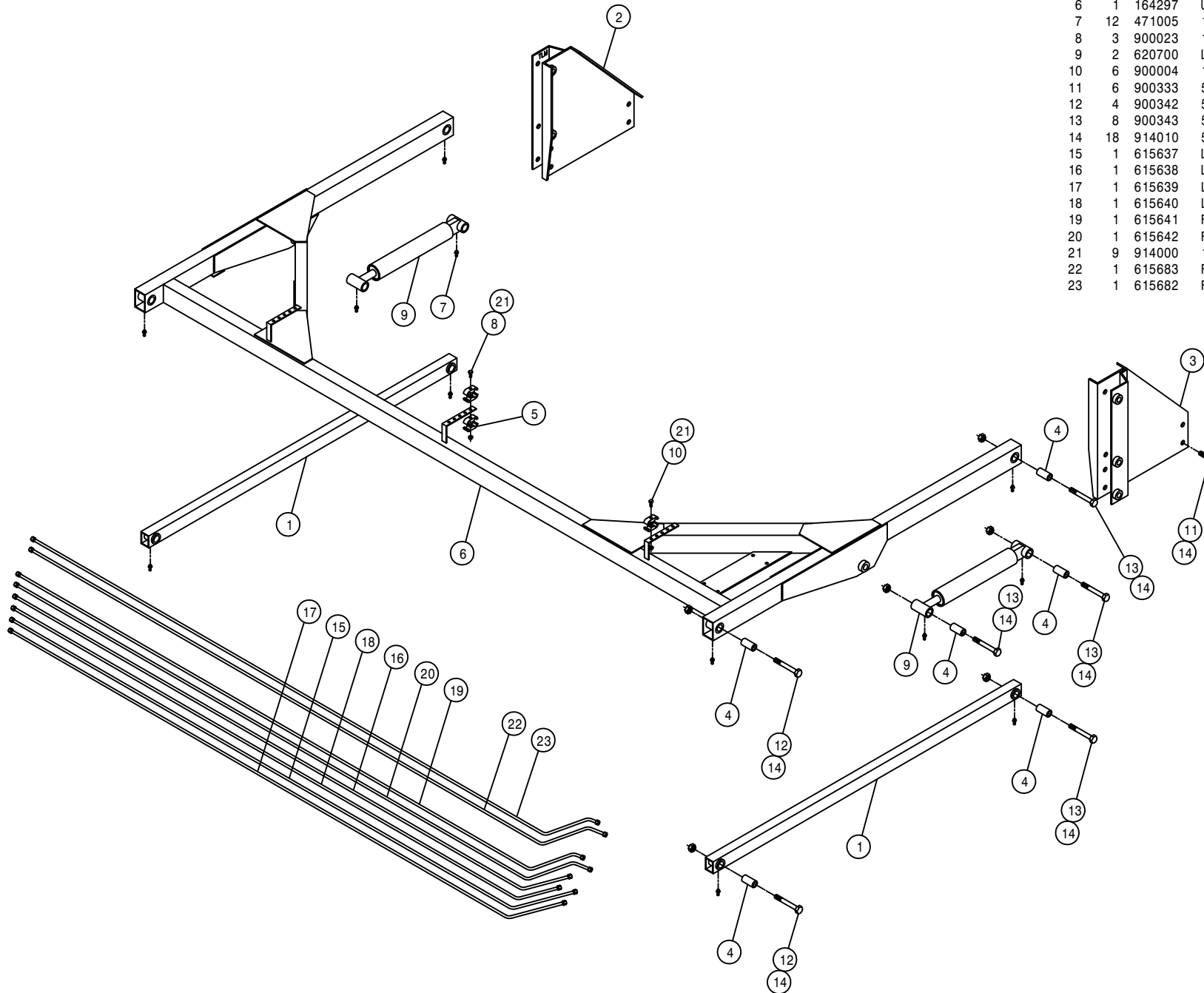

TRANSOM ASSEMBLY

DET. QTY PART NO. DESCRIPTION

DET.	QTY	PART NO.	DESCRIPTION	
1	2	160429	FEEDER HOSE SUPPORT SPRING MT	
2	4	160691	BUSH LIFT ARM LONG 470	
3	2	164123	NOZL MT TUBE, 254/284	96
4	2	164125	NOZL MT TUBE HANGER CHAN	96
5	2	164127	NOZL MT TUBE CLAMP	96
6	2	164128	LEVEL CYL PIVOT BRKT WLD	96
7	2	164315	BOOM BREAKAWAY WLD	97
8	2	900848	5/8UNC X 4 3/4 HEX BOLT GR8	
9	2	470136	3/8UNC-3 1/16ID-3 SQ U-BOLT	
10	4	164264	5/8UNC X 3" EYE BOLT	
11	6	471005	1/4 28 X 1/2 GREASE ZERK	
12	8	900007	1/4UNC X 2" HEX BOLT	
13	2	900847	5/8UNC X 4 1/2 HEX BOLT GR8	
14	4	910010	5/8UNC HEX NUT	
15	8	914000	1/4UNC HEX STOVER NUT	
16	4	914004	3/8UNC HEX STOVER NUT	
17	1	164308	TRANSOM WLD, 284	97
18	12	914010	5/8UNC HEX STOVER NUT	
19	8	920005	5/8 SAE FLAT WASHER	
20	4	920006	3/4 SAE FLAT WASHER	
21	2	164230	BOOM PIVOT PIN, .75 X 13.31 96	
22	4	470162	COTTER PIN 3/16 X 1 1/2 SQ CUT	
23	2	482000	SPRING, .930D X 8.5LG, .072WIRE	
24	2	520126	CUSH HOSE CLAMP 2IN X 5/8W	
25	2	620584	LEVEL CYL ASSY W/FTGS	96
26	2	620651	FOLD CYL ASSY W/FTGS	97
27	4	900829	5/8UNC X 4" HEX BOLT GR8	
28	2	900844	5/8UNC X 2 3/4 HEX BOLT GR8	
29	2	471023	GREASE ZERK 1/4-28 X 45	
30	4	520099	HOSE CLAMP NO 40 STAINLESS	
31	2	620630	ACCUMULATOR ASSY, 60' BOOM 96	
32	2	620631	ACCUMULATOR ASSY, 80/90' BOOM 96	
33	4	629735	CAPLUG, 1 1/4" SQ, BLACK POLY	

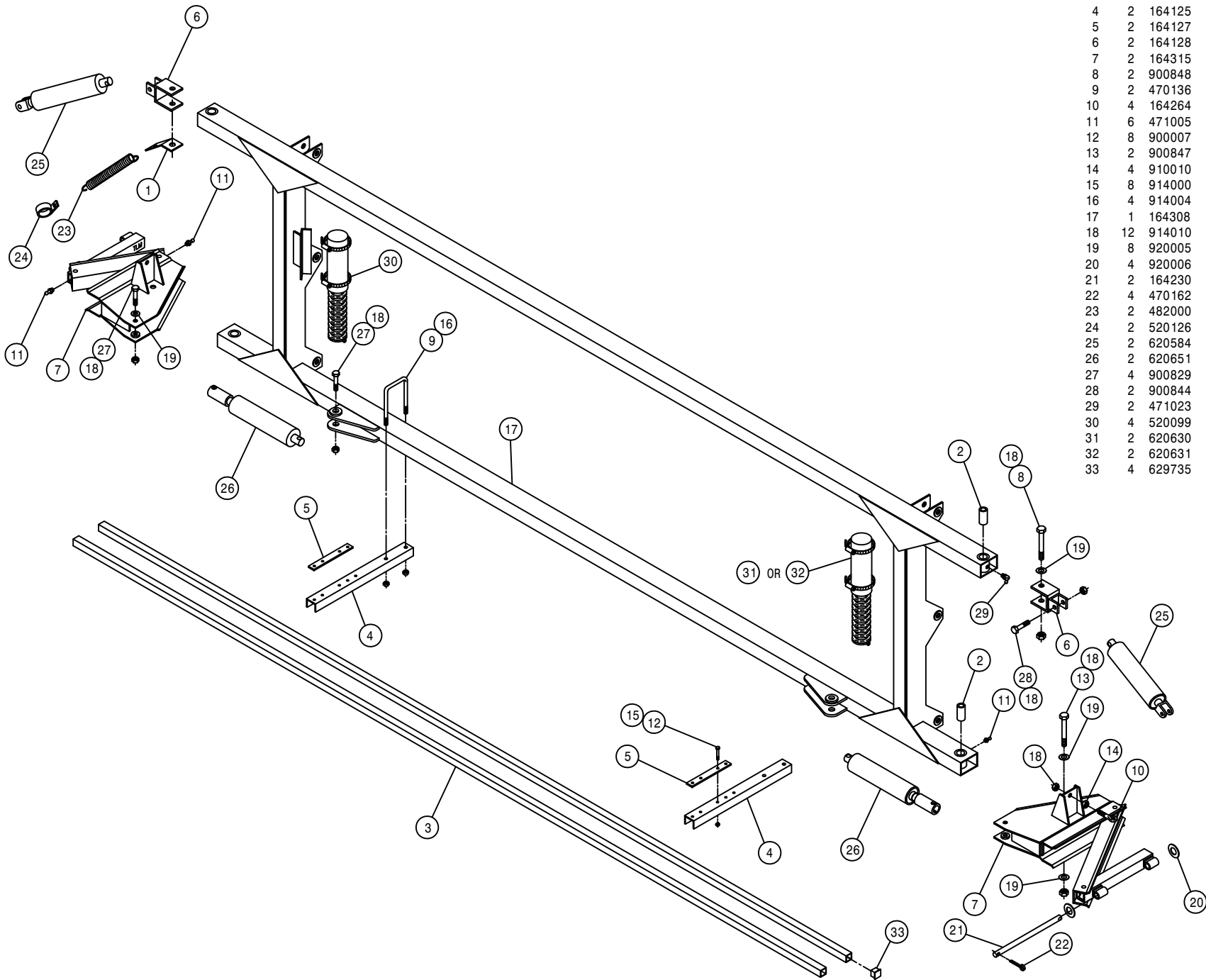

51

191051

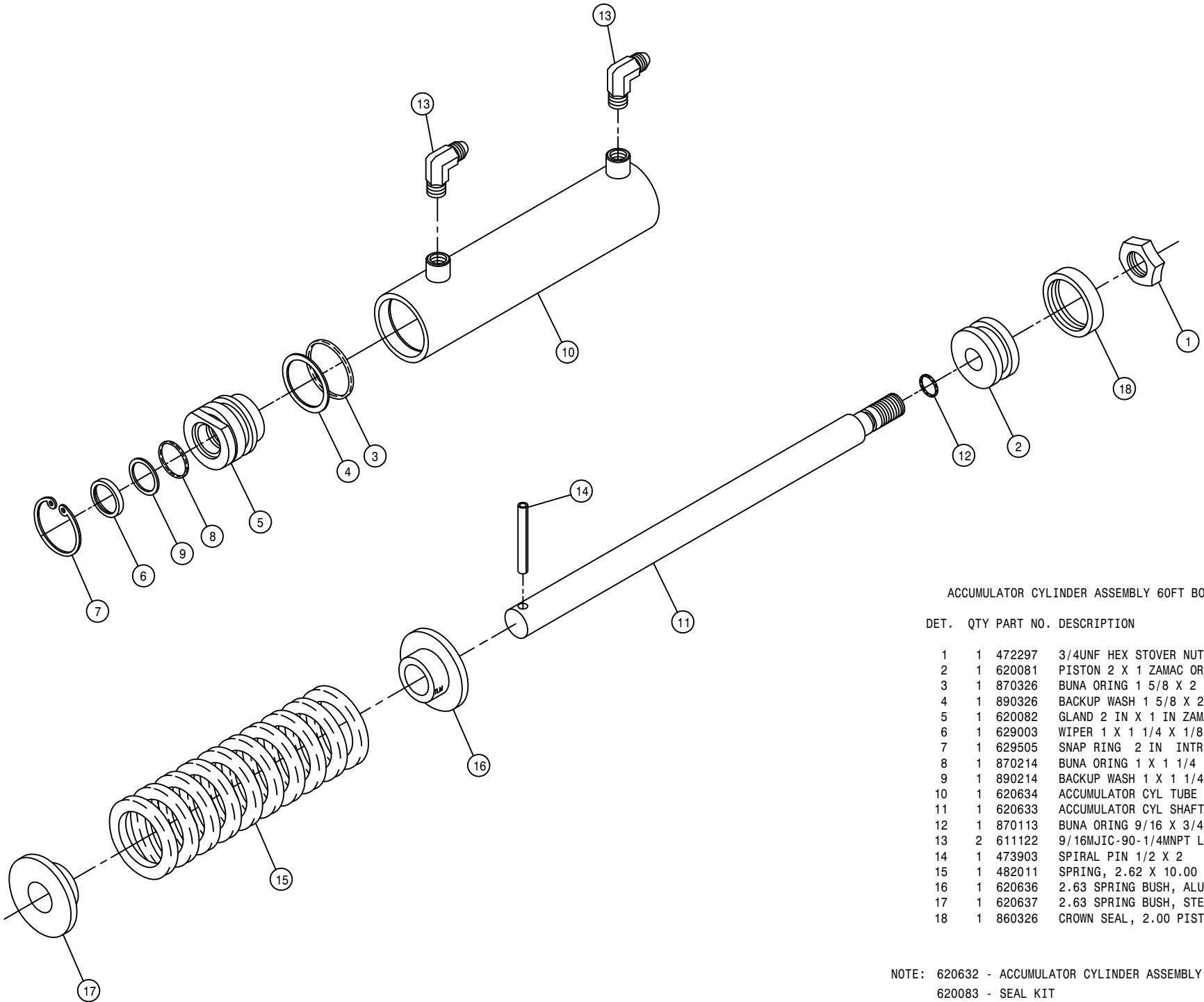

ACCUMULATOR CYLINDER ASSEMBLY 60FT BOOM

DET.	QTY	PART NO.	DESCRIPTION
	1	472297	3/4UNF HEX STOVER NUT THIN
	1	620081	PISTON 2 X 1 ZAMAC ORING TYPE
	1	870326	BUNA ORING 1 5/8 X 2
	1	890326	BACKUP WASH 1 5/8 X 2 LEATH
	1	620082	GLAND 2 IN X 1 IN ZAMAC
	1	629003	WIPER 1 X 1 1/4 X 1/8
	1	629505	SNAP RING 2 IN INTRN
	1	870214	BUNA ORING 1 X 1 1/4
	1	890214	BACKUP WASH 1 X 1 1/4 HT2022
	1	620634	ACCUMULATOR CYL TUBE WLD 96
	1	620633	ACCUMULATOR CYL SHAFT 96
	1	870113	BUNA ORING 9/16 X 3/4
	2	611122	9/16MJIC-90-1/4MNPT LBO
	1	473903	SPIRAL PIN 1/2 X 2 640
	1	482011	SPRING, 2.62 X 10.00 COMPRSN
	1	620636	2.63 SPRING BUSH, ALUM 96
	1	620637	2.63 SPRING BUSH, STEEL 96
	1	860326	CROWN SEAL, 2.00 PISTON (326

NOTE: 620632 - ACCUMULATOR CYLINDER ASSEMBLY 1-12
 620083 - SEAL KIT

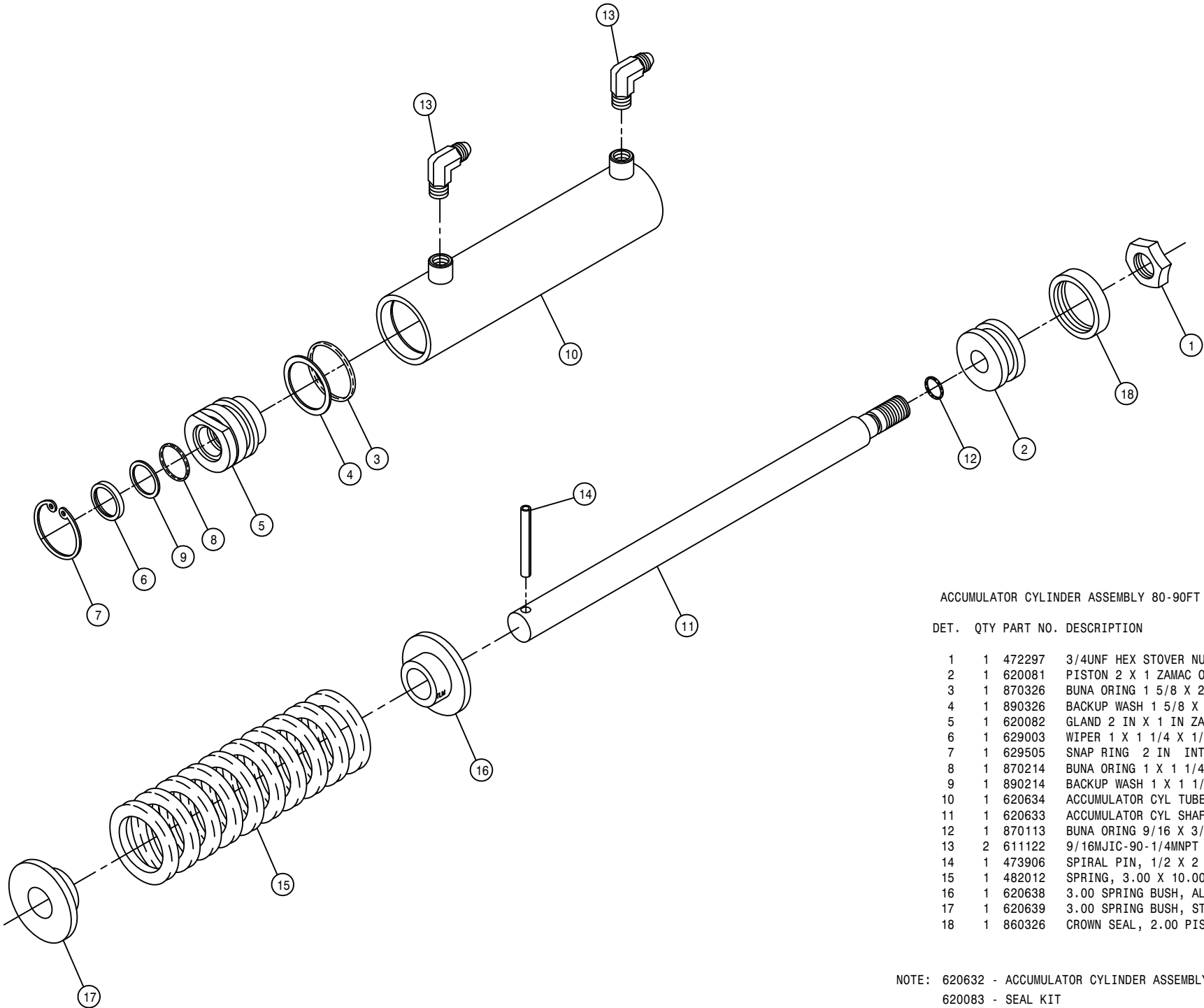

ACCUMULATOR CYLINDER ASSEMBLY 80-90FT BOOM

DET.	QTY	PART NO.	DESCRIPTION
	1	472297	3/4UNF HEX STOVER NUT THIN
	2	620081	PISTON 2 X 1 ZAMAC ORING TYPE
	3	870326	BUNA ORING 1 5/8 X 2
	4	890326	BACKUP WASH 1 5/8 X 2 LEATH
	5	620082	GLAND 2 IN X 1 IN ZAMAC
	6	629003	WIPER 1 X 1 1/4 X 1/8
	7	629505	SNAP RING 2 IN INTRN
	8	870214	BUNA ORING 1 X 1 1/4
	9	890214	BACKUP WASH 1 X 1 1/4 HT2022
	10	620634	ACCUMULATOR CYL TUBE WLD 96
	11	620633	ACCUMULATOR CYL SHAFT 96
	12	870113	BUNA ORING 9/16 X 3/4
	13	611122	9/16MJIC-90-1/4MNPT LBO
	14	473906	SPIRAL PIN, 1/2 X 2 1/2 LG
	15	482012	SPRING, 3.00 X 10.00 COMPRSN
	16	620638	3.00 SPRING BUSH, ALUM 96
	17	620639	3.00 SPRING BUSH, STEEL 96
	18	860326	CROWN SEAL, 2.00 PISTON (326)

NOTE: 620632 - ACCUMULATOR CYLINDER ASSEMBLY 1-12
 620083 - SEAL KIT

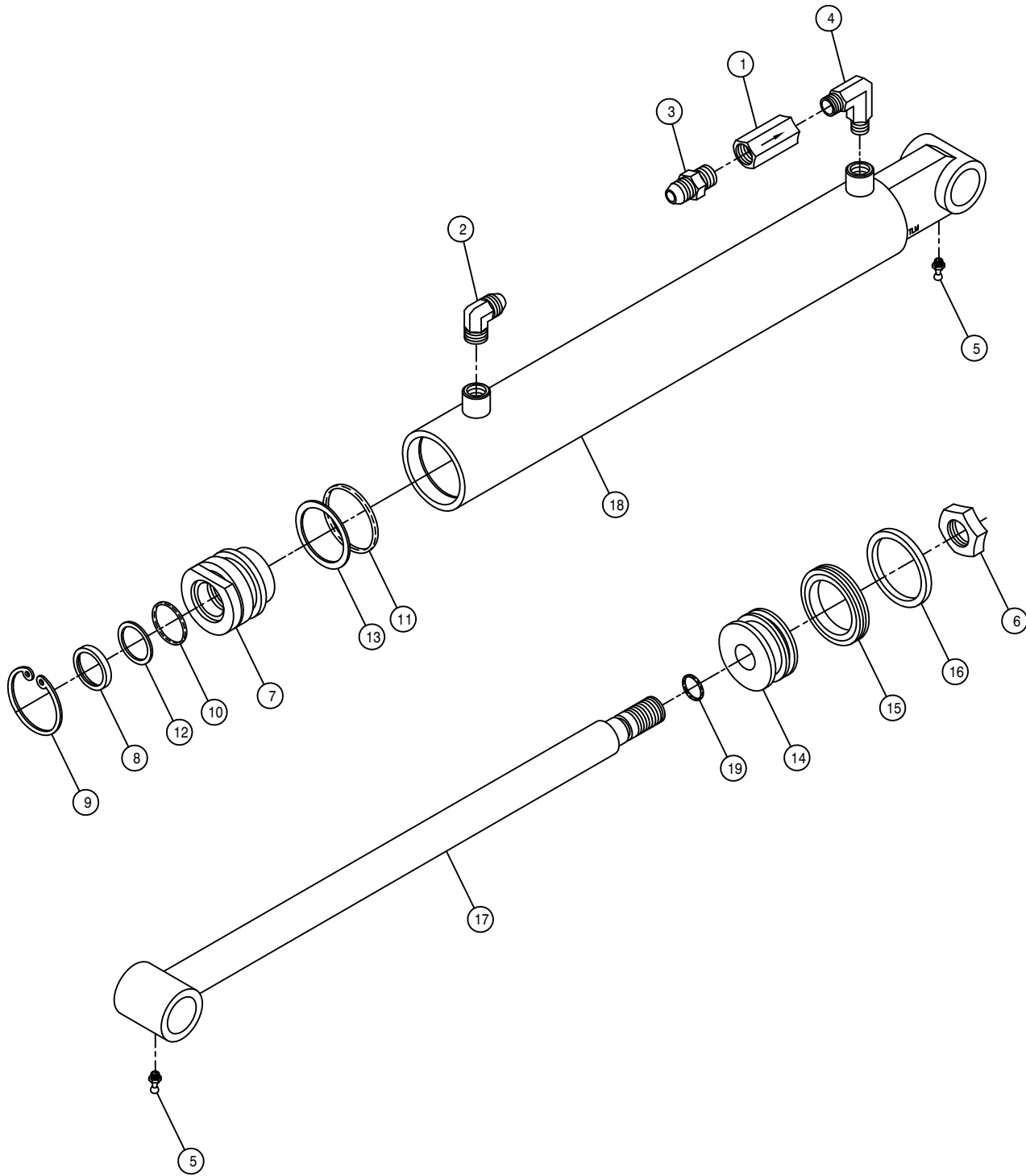

LIFT CYLINDER ASSEMBLY

DET.	QTY	PART NO.	DESCRIPTION
	1	610675	RESTRICTOR, .042 1-WAY, 1/2FNPT
	1	611122	9/16MJIC-90-1/4MNPT LBO
	1	618018	9/16MJIC-1/2MNPT ADPTR
	1	618633	1/2MNPT-90-1/4MNPT REDU LBO
	2	471005	1/4 28 X 1/2 GREASE ZERK
	1	472297	3/4UNF HEX STOVER NUT THIN
	1	620675	GLAND, 2.50OD X 1.25ID, ALUM
	1	629002	WIPER 1 1/4 X 1 1/2 X 1/8
	1	629504	SNAP RING 2 1/2 IN INTRN
	1	870218	BUNA ORING 1 1/4 X 1 1/2
	1	870330	NEO ORING 2 1/8 X 2 1/2
	1	890218	BACKUP WASH1 1/4X1 1/2 HT2022
	1	890330	BACKUP WASH 2 1/8 X 2 1/2
	1	620703	PISTON, 2.50" T-SEAL/WEAR RING
	1	860330	T-SEAL, 2.50 OD W/BACKUPS(330)
	1	860331	WEAR RING, .25 X 2.50
	1	620704	LIFT CYL SHAFT WLD 99
	1	620706	LIFT CYL TUBE WLD, 2.50" 99
	1	870113	BUNA ORING 9/16 X 3/4

NOTE: 1. 620701 - LIFT CYLINDER ASSEMBLY
 2. 620700 - LIFT CYLINDER ASSEMBLY WITH FITTINGS
 3. 620708 - SEAL KIT

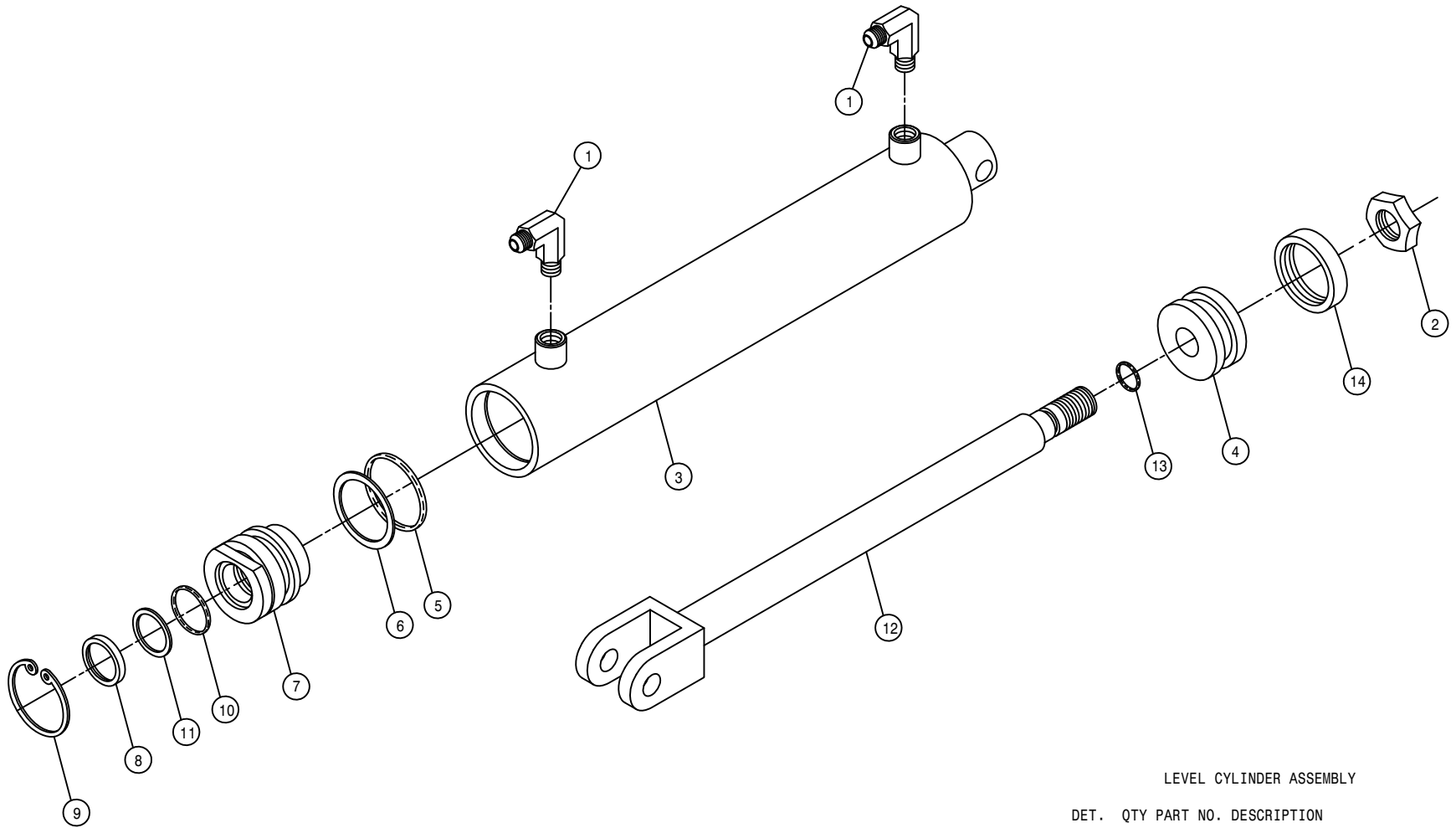

LEVEL CYLINDER ASSEMBLY

DET.	QTY	PART NO.	DESCRIPTION
1	2	611122	9/16MJIC-90-1/4MNPT LBO
2	1	472297	3/4UNF HEX STOVER NUT THIN
3	1	620586	LEVEL CYL TUBE WLD 96
4	1	620081	PISTON 2 X 1 ZAMAC ORING TYPE
5	1	870326	BUNA ORING 1 5/8 X 2
6	1	890326	BACKUP WASH 1 5/8 X 2 LEATH
7	1	620082	GLAND 2 IN X 1 IN ZAMAC
8	1	629003	WIPER 1 X 1 1/4 X 1/8
9	1	629505	SNAP RING 2 IN INTRN
10	1	870214	BUNA ORING 1 X 1 1/4
11	1	890214	BACKUP WASH 1 X 1 1/4 HT2022
12	1	620591	LEVEL CYL SHAFT WLD 96
13	1	870113	BUNA ORING 9/16 X 3/4
14	1	860326	CROWN SEAL, 2" PISTON, HYD

NOTE: 1. 620585 - LEVEL CLINDER ASSEMBLY
 2. 620584 - LEVEL CYLINDER ASSEMBLY W/FTGS
 3. 620083 - SEAL KIT

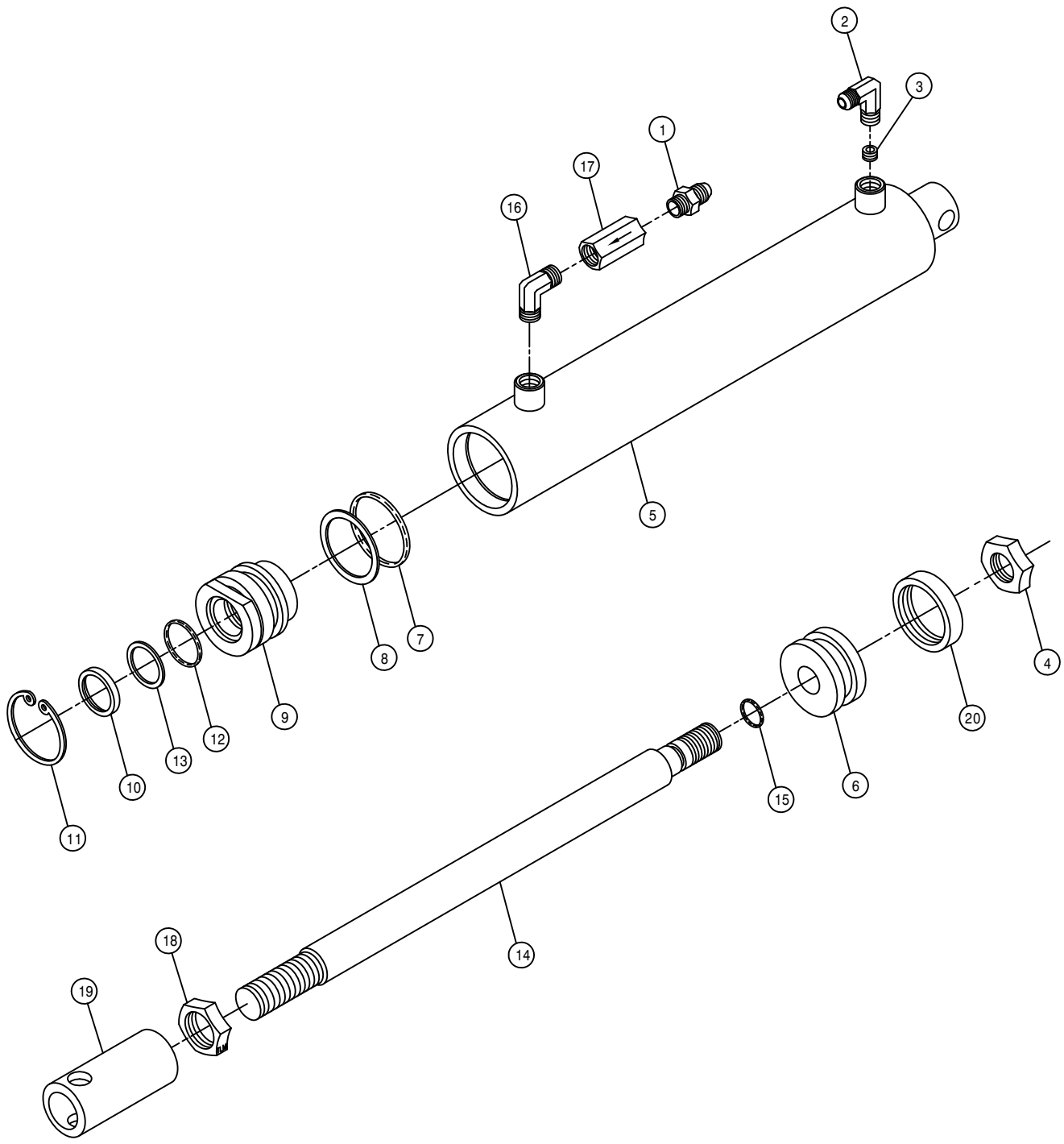

FOLD CYLINDER ASSEMBLY

DET.	QTY	PART NO.	DESCRIPTION
1	1	618018	9/16MJIC-1/2MNPT ADPTR
2	1	440338	9/16 JIC W/90X1/4 NPT TAPPED
3	1	614366	RESTRICTOR SCREW, .042 DIA
4	1	472297	3/4UNF HEX STOVER NUT THIN
5	1	620586	LEVEL CYL TUBE WLD 96
6	1	620081	PISTON 2 X 1 ZAMAC ORING TYPE
7	1	870326	BUNA ORING 1 5/8 X 2
8	1	890326	BACKUP WASH 1 5/8 X 2 LEATH
9	1	620082	GLAND 2 IN X 1 IN ZAMAC
10	1	629003	WIPER 1 X 1 1/4 X 1/8
11	1	629505	SNAP RING 2 IN INTRN
12	1	870214	BUNA ORING 1 X 1 1/4
13	1	890214	BACKUP WASH 1 X 1 1/4 HT2022
14	1	620596	FOLD CYL SHAFT 96
15	1	870113	BUNA ORING 9/16 X 3/4
16	1	618633	1/2MNPT-90-1/4MNPT REDU LBO
17	1	610450	RESTRICTOR .025 1-WAY, 1/2FNPT
18	1	472322	7/8UNF HEX JAM NUT
19	1	620653	FOLD CYL ADJ SLEEVE 97
20	1	860326	CROWN SEAL, 2" PISTON, HYD

NOTE: 1. 620652 - FOLD CLINDER ASSEMBLY
 2. 620651 - FOLD CYLINDER ASSEMBLY WITH FITTINGS
 3. 614365 - RESTRICTOR ELBOW ASSEMBLY
 4. 620083 - SEAL KIT

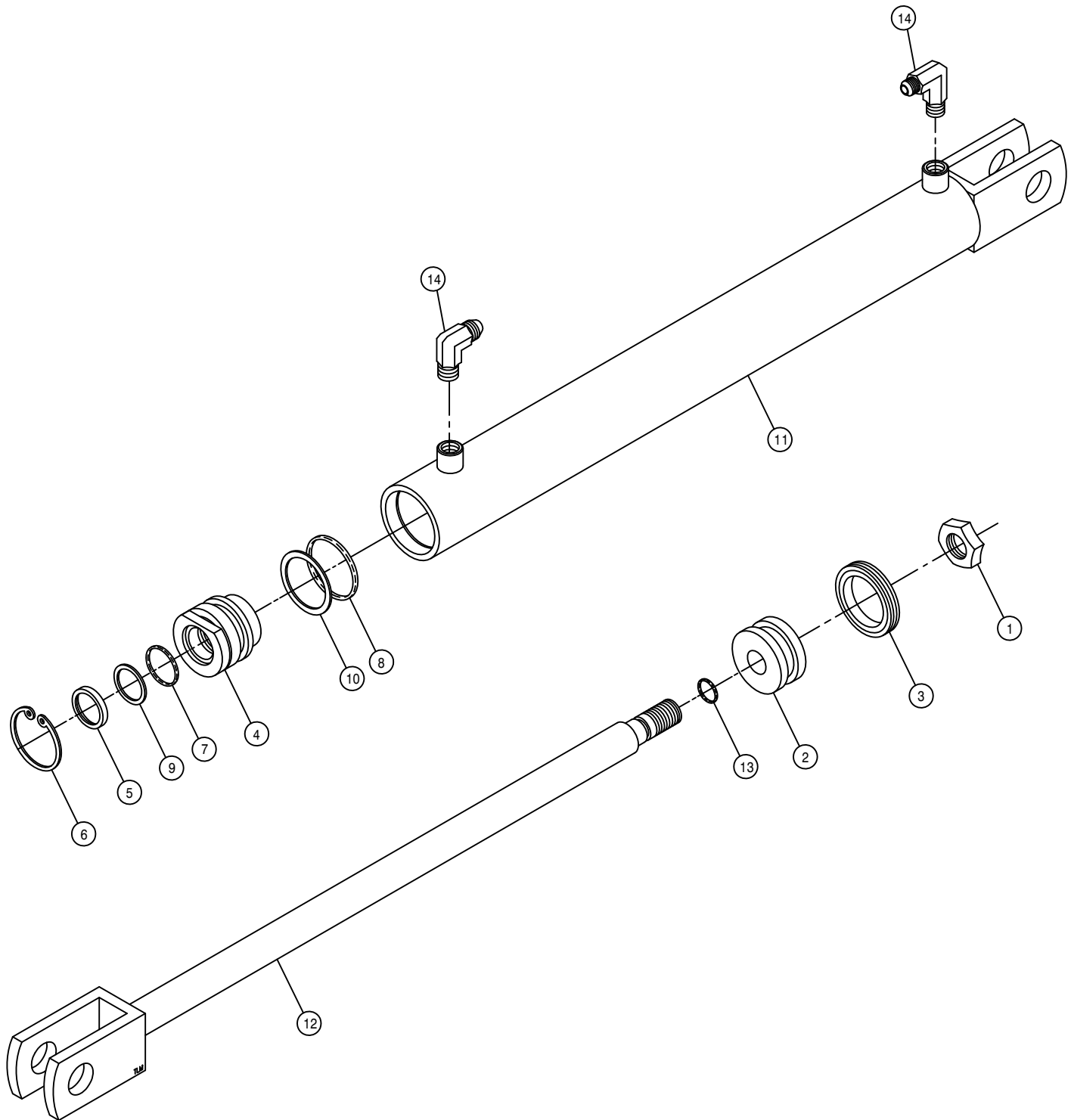

BOOM EXTENSION FOLD CYLINDER ASSEMBLY

DET.	QTY	PART NO.	DESCRIPTION	
	1	472297	3/4UNF HEX STOVER NUT THIN	
	2	620666	PISTON, 2.50" T-SEAL TYPE	
	3	860330	T-SEAL, 2.50 OD W/BACKUPS	
	4	620668	GLAND, 2.500D X 1.00ID O-RING	
	5	629003	WIPER 1 X 1 1/4 X 1/8	
	6	629504	SNAP RING 2 1/2 IN INTRN	
	7	870214	BUNA ORING 1 X 1 1/4	
	8	870330	NEO ORING 2 1/8 X 2 1/2	
	9	890214	BACKUP WASH 1 X 1 1/4 HT2022	
	10	890330	BACKUP WASH 2 1/8 X 2 1/2	
	11	620669	CYL TUBE WLD, BOOM FOLD	98
	12	620688	CYL SHAFT WLD, BOOM FOLD	98
	13	870113	BUNA ORING 9/16 X 3/4	
	14	2 614365	RESTRICTOR ELBOW ASSY .042DIA	

NOTE: 620664 - LIFT CYLINDER INCLUDES ITEMS 1-13.
 620671 - SEAL KIT

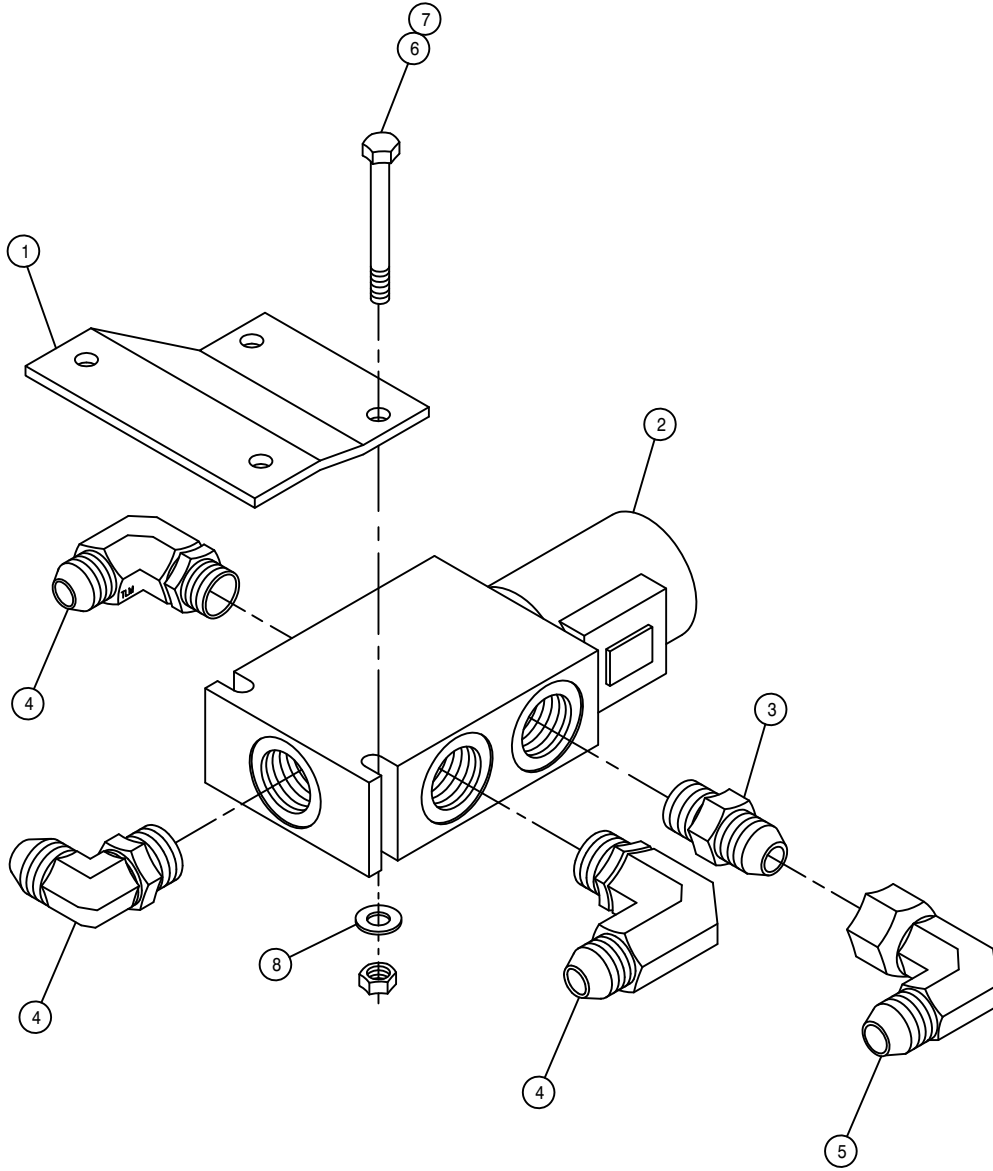

LIFT CYLINDER LOCK SOLENOID VALVE ASSEMBLY

DET. QTY PART NO. DESCRIPTION

1	1	164305	LIFT CYL LOCK SOL VLV MT	97
2	1	610628	4-WAY, 2-POSITION SOL VLV	
3	1	618109	9/16MJIC-3/4MOR ADPTR	
4	3	618115	9/16MJIC-90-3/4MOR LBO	
5	1	618618	9/16MJIC-90-9/16FJIC SWIV LBO	
6	2	900006	1/4UNC X 1 3/4 HEX BOLT	
7	2	914000	1/4UNC HEX STOVER NUT	
8	2	920000	1/4 SAE FLAT WASHER	

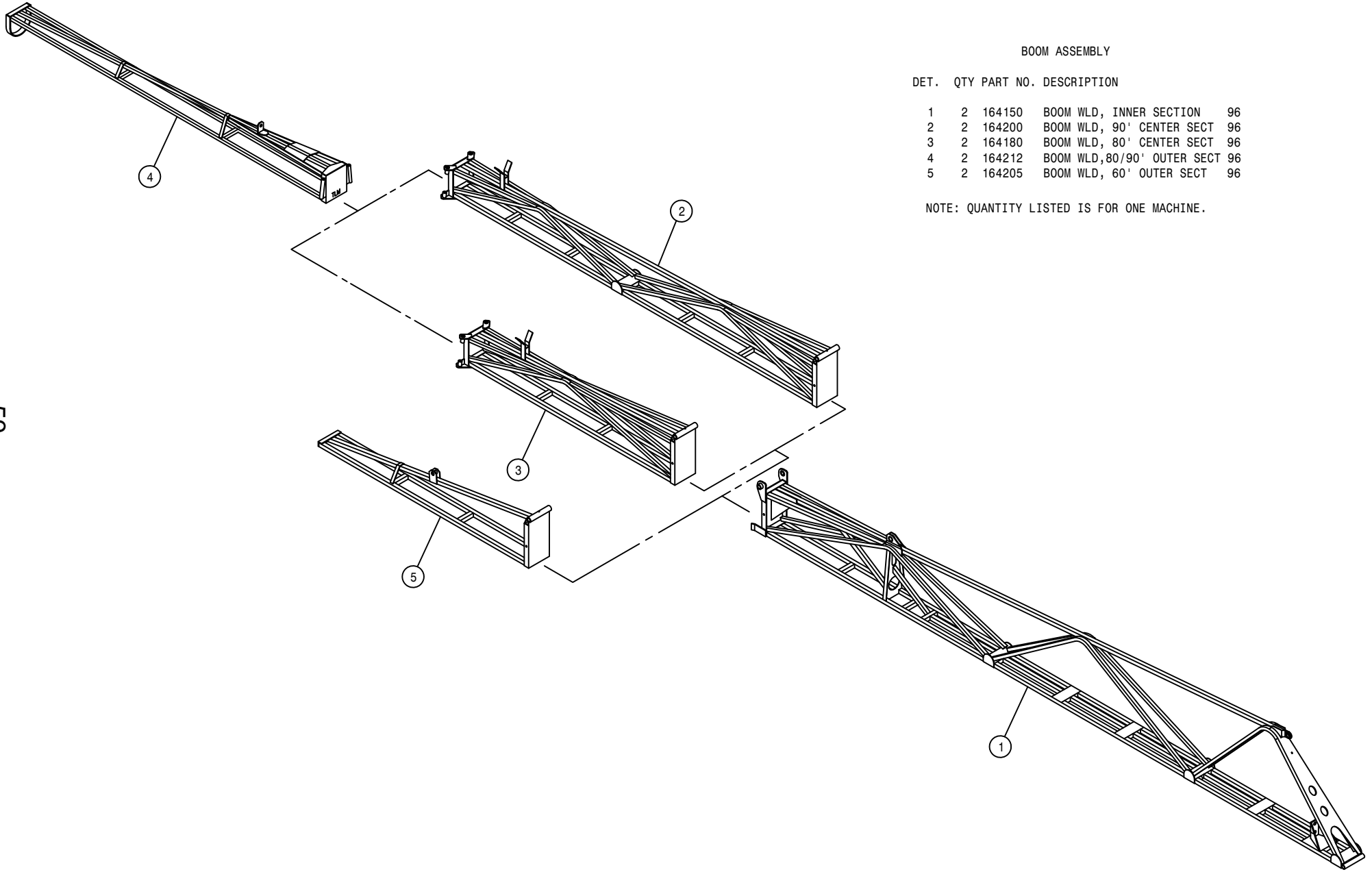

BOOM ASSEMBLY

DET.	QTY	PART NO.	DESCRIPTION	
1	2	164150	BOOM WLD, INNER SECTION	96
2	2	164200	BOOM WLD, 90' CENTER SECT	96
3	2	164180	BOOM WLD, 80' CENTER SECT	96
4	2	164212	BOOM WLD,80/90' OUTER SECT	96
5	2	164205	BOOM WLD, 60' OUTER SECT	96

NOTE: QUANTITY LISTED IS FOR ONE MACHINE.

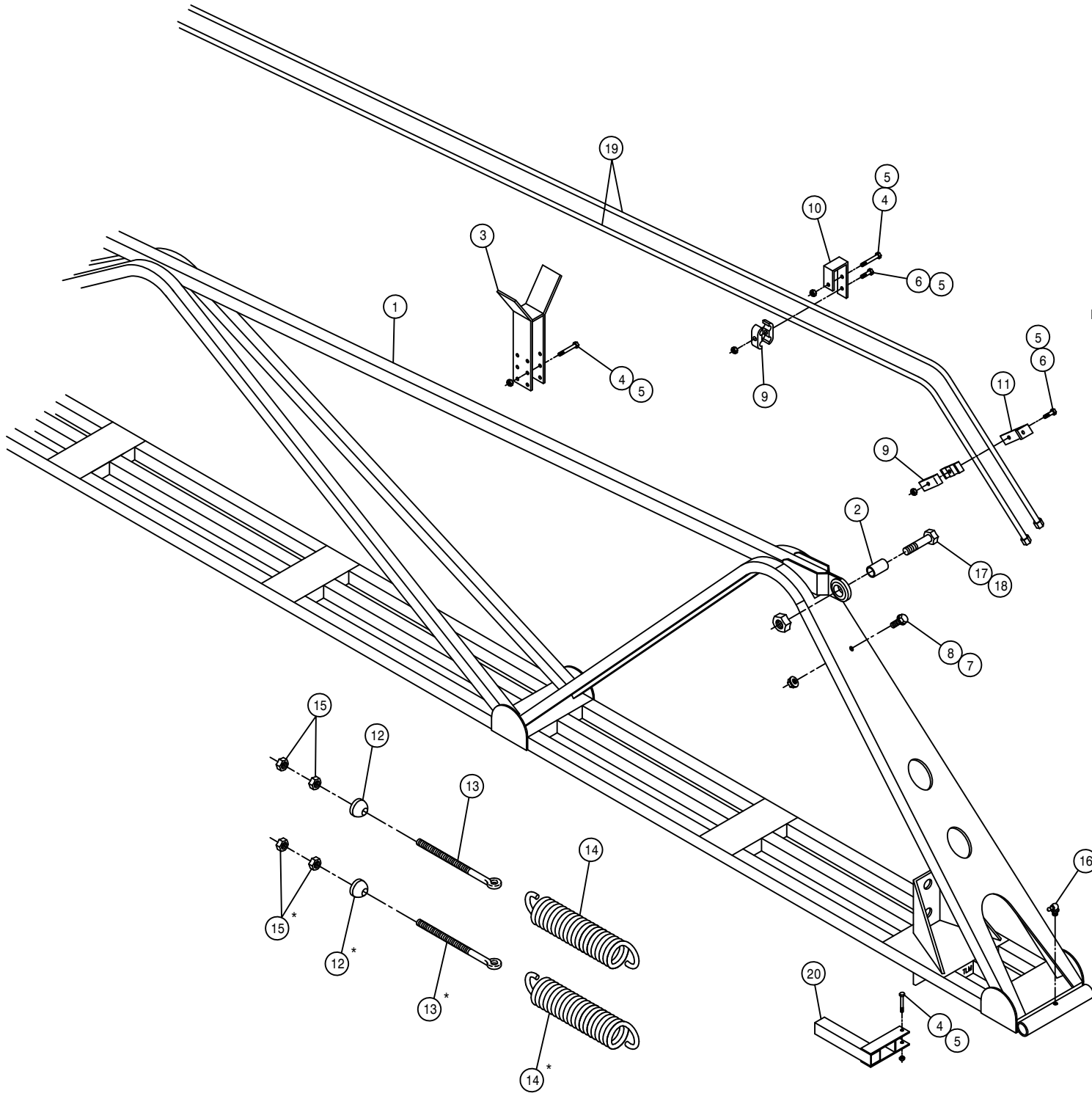

INNER BOOM ASSEMBLY

DET.	QTY	PART NO.	DESCRIPTION	
1	2	164150	BOOM WLD, INNER SECTION	96
2	2	164227	BOOM BALL JOINT BUSH	96
3	2	164266	OUTER BOOM SUPP WLD,80/90'	96
4	18	900007	1/4UNC X 2" HEX BOLT	
5	20	914000	1/4UNC HEX STOVER NUT	
6	10	900004	1/4UNC X 1 1/4 HEX BOLT	
7	2	470121	1/4UNC HEX FLANGE LOCK NUT	
8	2	470118	1/4UNC X 3/4 FLANGE HEX BOLT	
9	10	470287	TUBE CLAMP, .375-.375 (PAIR)	
10	8	164242	HYD TUBE HANGER CLEVIS,BOOM96	
11	2	164243	HYD TUBE HANGER ANGLE,BOOM 96	
12	4	164263	SWIVEL, 5/8 BOOM EYEBOLT	
13	4	164265	5/8UNC X 7 1/2 EYE BOLT	
14	4	482014	SPRING,3.25 X 11.50 EXTENSION	
15	8	910010	5/8UNC HEX NUT	
16	2	471028	GREASE ZERK, 1/4-28 90DEG	
17	2	900844	5/8UNC X 2 3/4 HEX BOLT GR8	
18	2	914010	5/8UNC HEX STOVER NUT	
19	4	615684	HYD TUBE ASSY,BOOM EXT FOLD96	
20	2	164275	NOZL MT WLD	96

NOTE: QUANTITY LISTED IS FOR ONE MACHINE.
 *60 FOOT BOOM USES ONE SPRING SETUP.

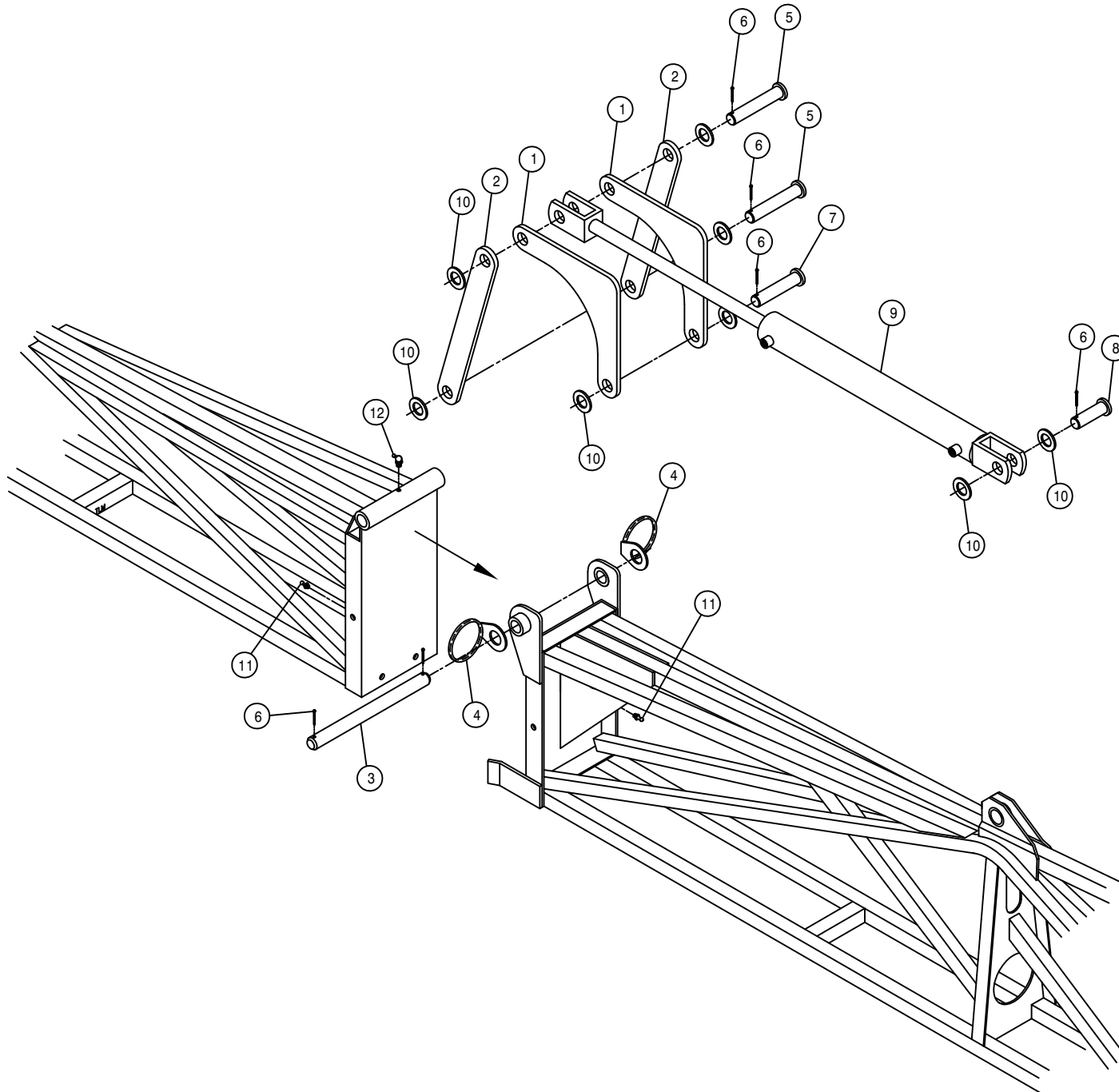

80-90 FOOT BOOM HINGE PIVOT ASSEMBLY

DET.	QTY	PART NO.	DESCRIPTION	
1	4	164228	FOLDING LINK, INNER BOOM	96
2	4	164229	FOLDING LINK, BOOM CNTR SECT	96
3	2	164231	BOOM PIN, 1.00 X 11.75	96
4	4	438302	HOSE SUPPORT RING WLD W/WASHER	
5	4	470155	CLEVIS PIN, 1.00 X 4.00	PLT
6	12	470162	COTTER PIN 3/16 X 1 1/2	SQCUT
7	2	472012	CLEVIS PIN, 1.00 X 3.25	PLT
8	2	472270	CLEVIS PIN, 1.00 X 2.50	PLT
9	2	620664	CYL ASSY, BOOM FOLD 2.50X18"	98
10	16	920008	1" SAE FLAT WASHER	
11	4	471005	1/4 28 X 1/2 GREASE ZERK	
12	2	471028	GREASE ZERK, 1/4-28 90DEG	

NOTE: QUANTITY LISTED IS FOR ONE MACHINE.

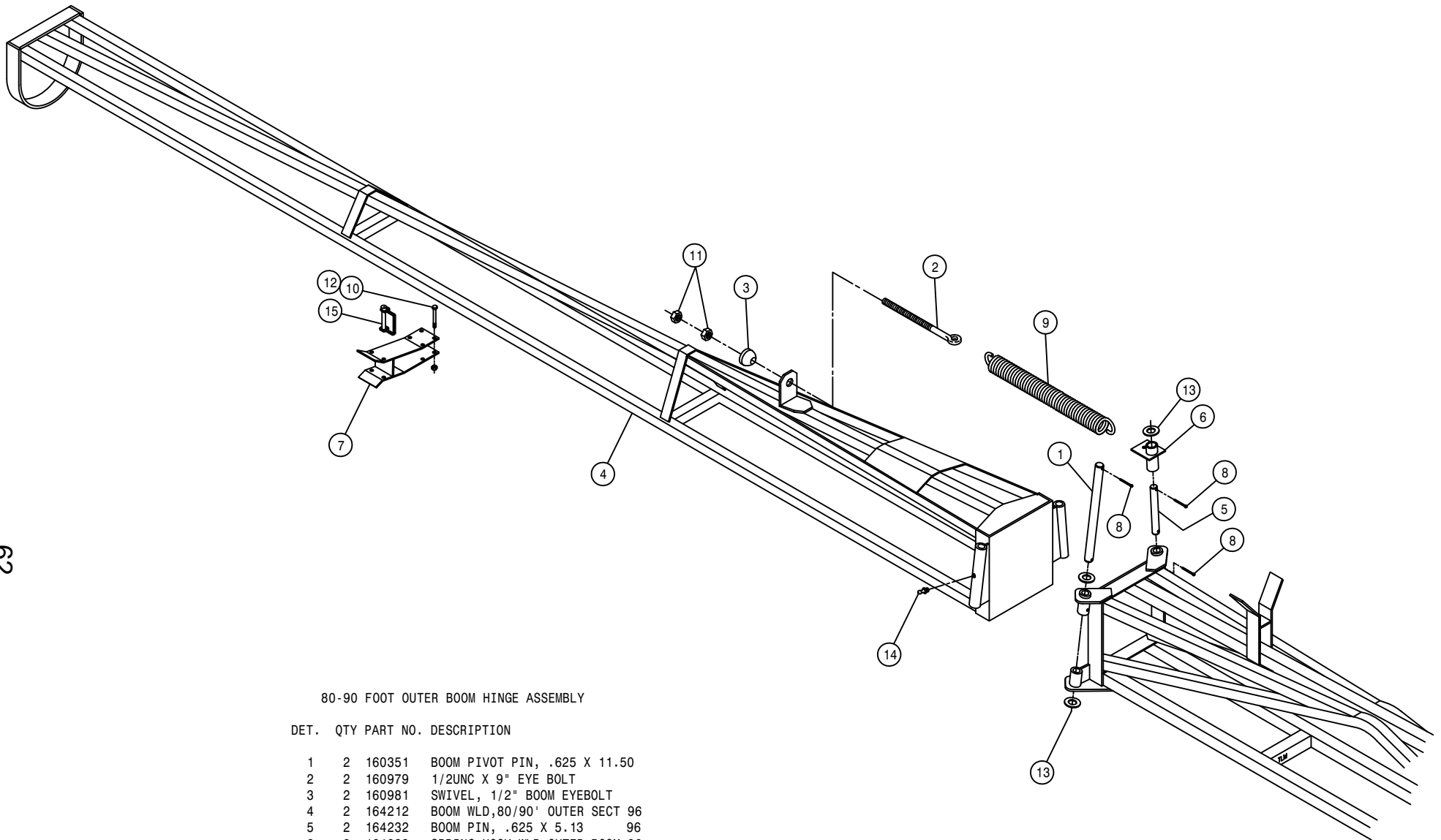

80-90 FOOT OUTER BOOM HINGE ASSEMBLY

DET.	QTY	PART NO.	DESCRIPTION
1	2	160351	BOOM PIVOT PIN, .625 X 11.50
2	2	160979	1/2UNC X 9" EYE BOLT
3	2	160981	SWIVEL, 1/2" BOOM EYEBOLT
4	2	164212	BOOM WLD,80/90' OUTER SECT 96
5	2	164232	BOOM PIN, .625 X 5.13 96
6	2	164233	SPRING HOOK WLD, OUTER BOOM 96
7	2	164236	OUTER BOOM SUPPORT WLD 96
8	8	470162	COTTER PIN 3/16 X 1 1/2 SQCUT
9	2	482013	SPRING, 2.50 X 17.00 EXTENSION
10	8	900006	1/4UNC X 1 3/4 HEX BOLT
11	4	910008	1/2UNC HEX NUT
12	8	914000	1/4UNC HEX STOVER NUT
13	6	920005	5/8 SAE FLAT WASHER
14	2	471005	1/4 28 X 1/2 GREASE ZERK
15	2	473895	1/4 X 1 3/4 LYNCH PIN

NOTE: QUANTITY LISTED IS FOR ONE MACHINE.

60 FOOT BOOM HINGE PIVOT ASSEMBLY

DET. QTY PART NO. DESCRIPTION

1	2	164205	BOOM WLD, 60' OUTER SECT	96
2	2	164231	BOOM PIN, 1.00 X 11.75	96
3	4	470162	COTTER PIN 3/16 X 1 1/2 SQ CUT	
4	2	472276	CLEVIS PIN, 1.00 X 2.00	PLT
5	2	611016	HAIR PIN #6	
6	4	900128	3/8UNC X 3/4 HEX BOLT	
7	4	914004	3/8UNC HEX STOVER NUT	
8	4	438302	HOSE SUPPORT RING WLD W/WASHER	
9	2	471005	1/4 28 X 1/2 GREASE ZERK	
10	2	471028	GREASE ZERK, 1/4-28 90DEG	

NOTE: QUANTITY LISTED IS FOR ONE MACHINE.

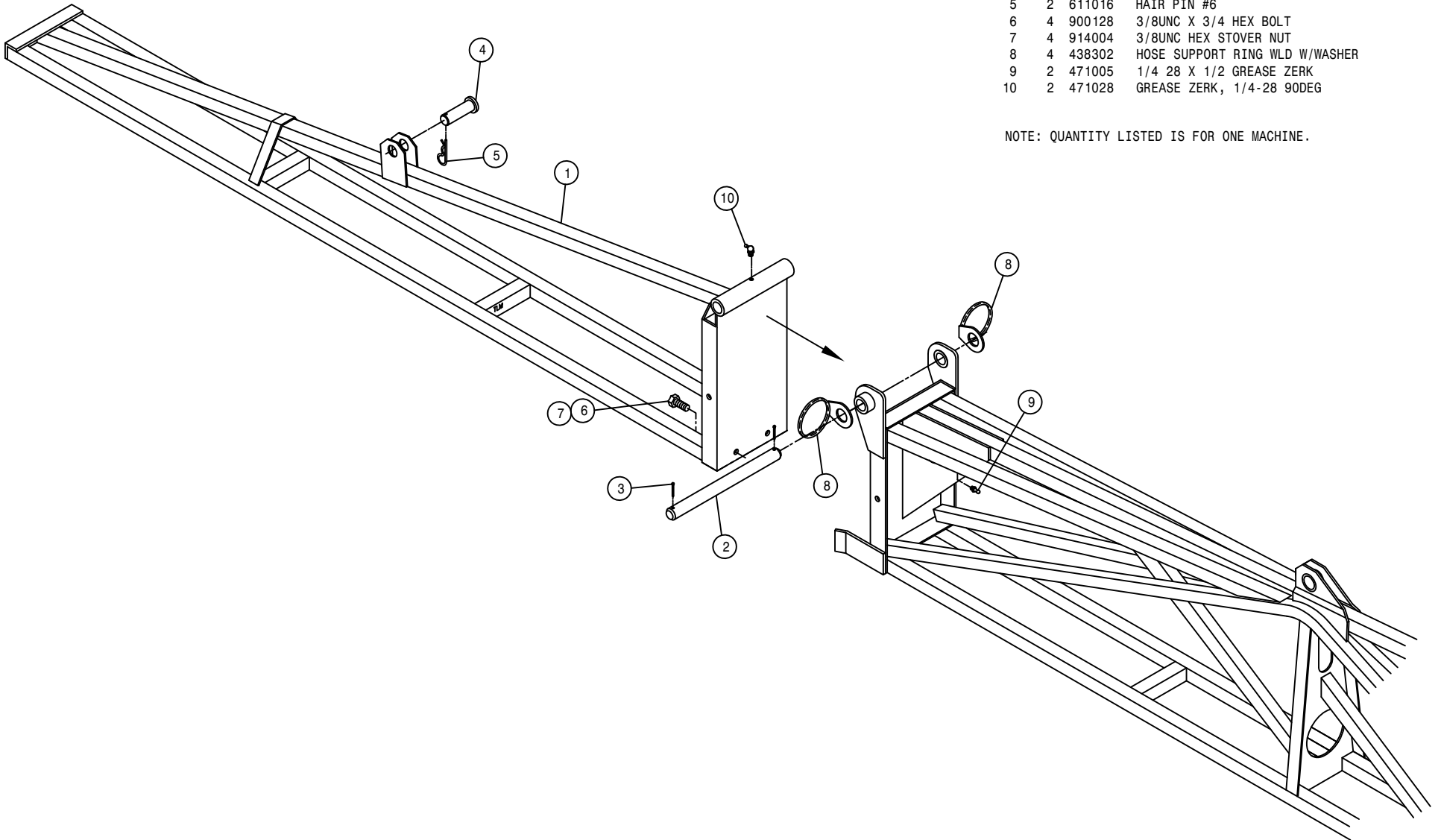

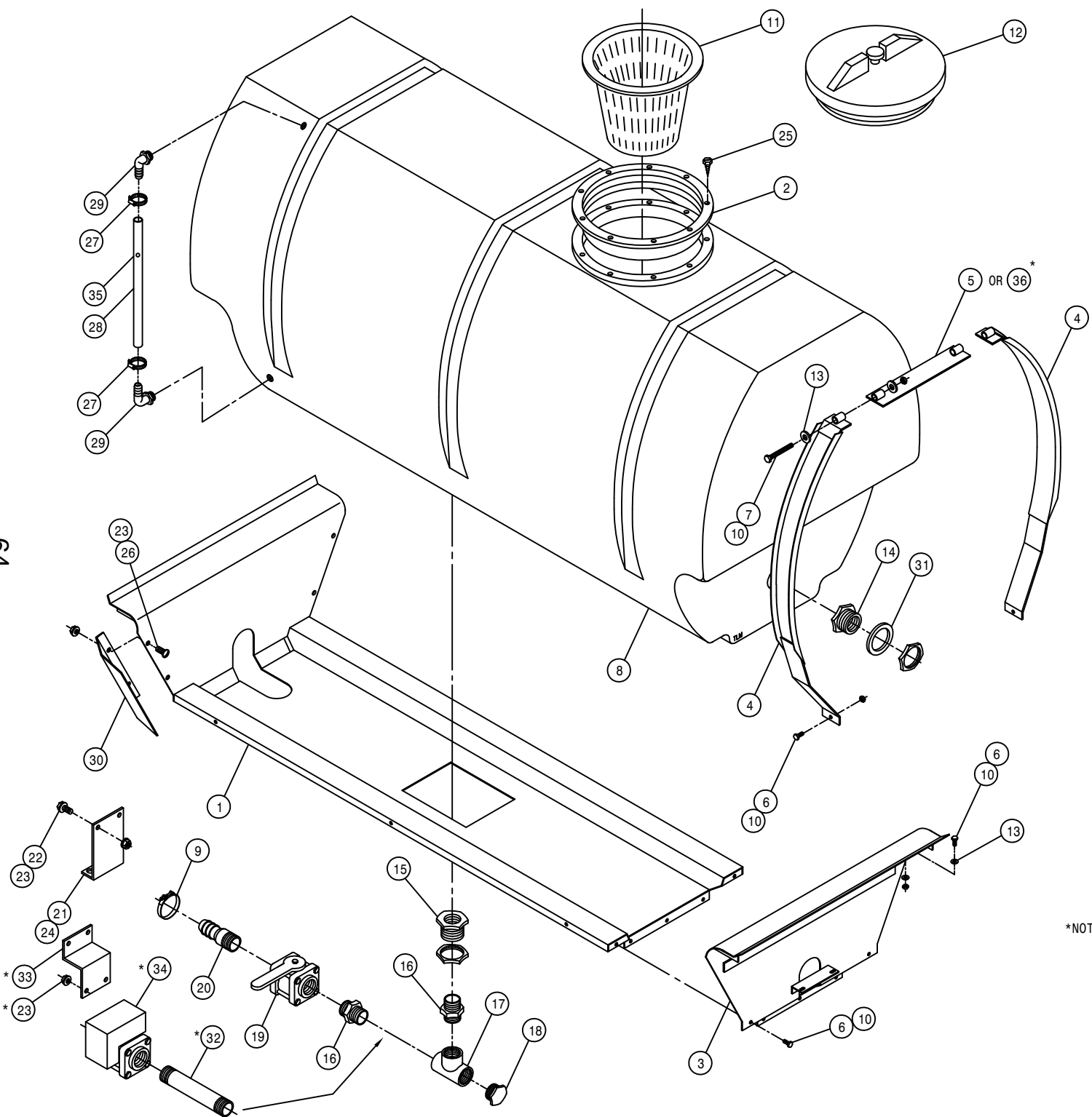

RH POLY 400 GALLON SOLUTION TANK ASSEMBLY

DET.	QTY	PART NO.	DESCRIPTION
		5 OR 36*	
1	1	763434	POLY TANK CRADLE WELD, 284 94
2	1	763409	10" THD'D RING FOR TANK LID
3	1	763340	REAR POLY CRADLE MT WLD280 90
4	6	763454	TANK BAND WLD, 284 POLY 95
5	3	763456	TANK BAND TIE WLD,284 POLY 95
6	15	900129	3/8UNC X 1" HEX BOLT
7	6	906138	3/8UNC X 3 1/2 HEX BOLT FULL
8	1	763440	400 GAL GRAY POLY SOLU TANK
9	1	520133	1.81/2.06 T-BOLT HOSE CLAMP
10	21	914004	3/8UNC HEX STOVER NUT
11	1	763431	8" STRAINER BASKET, SOLU TANK
12	1	763408	LID, THD'D W/VENT, POLY TANK
13	20	920002	3/8 SAE FLAT WASHER
14	2	618548	1.25 PLASTIC FTG ASSY POLYTNK
15	1	618604	1.50 PLASTIC FTG ASSY-POLYTNK
16	2	500028	1 1/2NPT PIPE NIPPLE, POLY
17	1	500030	1 1/2"NPT PIPE TEE, POLY
18	1	500031	1 1/2NPT PIPE PLUG, POLY
19	1	696110	BALL VALVE 1 1/2FNPT POLY
20	1	500032	1 1/2NPT X 1 1/2 H BARB, POLY
21	1	763363	SOLU HOSE SUPPORT 280 POLY 91
22	2	470118	1/4UNC X 3/4 FLANGE HEX BOLT
23	6	470121	1/4UNC HEX FLANGE LOCK NUT
24	1	470000	CABLE TIE, 21" BLACK PLASTIC
25	8	763410	S.S. SCREW FOR CAP RING
26	2	472269	1/4UNC X 1/2 TRUSS HD BOLT
27	2	520069	HOSE CLAMP NO 6 STAINLESS
28	1	601245	HOSE, .50 X 42.00 SIGHT GAUGE
29	2	618556	1/4NPT-90-1/2 HOSE BARB,POLY
30	1	763436	RH SIGHT GAGE SHLD,POLY284 94
31	2	763430	1 1/4 TANK FLANGE RUBBER SEAL
32	1	500029	1 1/2NPT X 6 PIPE NIPPLE,POLY
33	1	763445	ELECT SOLU VLV SUPPORT 94
34	1	696161	1 1/2NPT ELECT SOLU VALVE
35	1	763446	RED POLYPROPYLENE BALL 25/64"
36	3	763460	BAND TIE/WALK MT WLD, 284 95

*NOTE: ITEMS 23,32,33, AND 34 ARE USED WITH THE ELECTRIC SOLUTION VALVE OPTION.

ITEM 36 IS USED WITH THE NARROW TREAD OPTION.

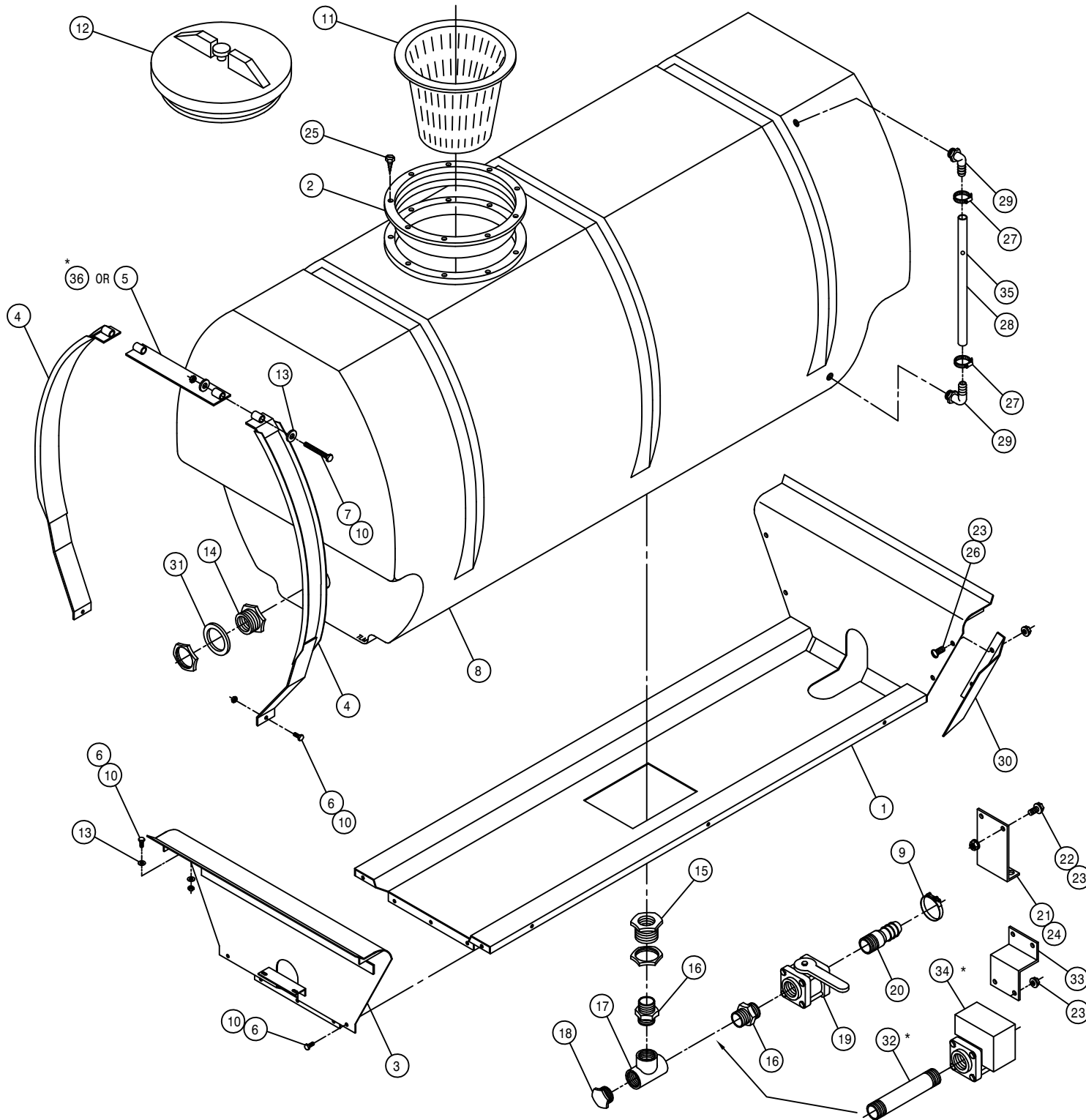

LH POLY 400 GALLON SOLUTION TANK ASSEMBLY

DET.	QTY	PART NO.	DESCRIPTION
	1	763434	POLY TANK CRADLE WELD, 284 94
	2	763409	10" THD'D RING FOR TANK LID
	3	763340	REAR POLY CRADLE MT WLD280 90
	4	763454	TANK BAND WLD, 284 POLY 95
	5	763456	TANK BAND TIE WLD,284 POLY 95
	6	900129	3/8UNC X 1" HEX BOLT
	7	906138	3/8UNC X 3 1/2 HEX BOLT FULL
	8	763440	400 GAL GRAY POLY SOLU TANK
	9	520133	1.81/2.06 T-BOLT HOSE CLAMP
	10	914004	3/8UNC HEX STOVER NUT
	11	763431	8" STRAINER BASKET, SOLU TANK
	12	763408	LID, THD'D W/VENT, POLY TANK
	13	920002	3/8 SAE FLAT WASHER
	14	618548	1.25 PLASTIC FTG ASSY POLYTNK
	15	618604	1.50 PLASTIC FTG ASSY-POLYTNK
	16	500028	1 1/2NPT PIPE NIPPLE, POLY
	17	500030	1 1/2"NPT PIPE TEE, POLY
	18	500031	1 1/2NPT PIPE PLUG, POLY
	19	696110	BALL VALVE 1 1/2FNPT POLY
	20	500032	1 1/2NPT X 1 1/2 H BARB, POLY
	21	763363	SOLU HOSE SUPPORT 280 POLY 91
	22	470118	1/4UNC X 3/4 FLANGE HEX BOLT
	23	470121	1/4UNC HEX FLANGE LOCK NUT
	24	470000	CABLE TIE, 21" BLACK PLASTIC
	25	763410	S.S. SCREW FOR CAP RING
	26	472269	1/4UNC X 1/2 TRUSS HD BOLT
	27	520069	HOSE CLAMP NO 6 STAINLESS
	28	601245	HOSE, .50 X 42.00 SIGHT GAUGE
	29	618556	1/4NPT-90-1/2 HOSE BARB,POLY
	30	763437	LH SIGHT GAGE SHLD,POLY284 94
	31	763430	1 1/4 TANK FLANGE RUBBER SEAL
	32	500029	1 1/2NPT X 6 PIPE NIPPLE,POLY
	33	763445	ELECT SOLU VLV SUPPORT 94
	34	696161	1 1/2NPT ELECT SOLU VALVE
	35	763446	RED POLYPROPYLENE BALL 25/64"
	36	763460	BAND TIE/WALK MT WLD, 284 95

*NOTE: ITEMS 23,32,33, AND 34 ARE USED WITH THE ELECTRIC SOLUTION VALVE OPTION.

ITEM 36 IS USED WITH THE NARROW TREAD OPTION.

65

191065

POLY TANK AGITATOR ASSEMBLY

DET. QTY PART NO. DESCRIPTION

1	4	470199	1/4UNC X 3/8 SQHD CUP SET SCR	
2	14	470089	1/4UNC HEX LOC NUT NYL INS SS	
3	6	470092	1/4UNC-3/4ID-1 1/4 U-BOLT SS	
4	2	610510	CESSNA GEAR MOTOR 1.48CI	
5	2	611121	9/16MJIC-1/4MNPT ADPTR	
6	4	618092	1 1/16MOR-1/2FNPT ADPTR	
7	4	618107	9/16MJIC-90-1/2MNPT LBO	
8	2	706403	FRT AGIT SHFT BRG, NYLON	
9	2	706401	REAR AGIT SHFT BRG, NYLON	
10	2	706402	AGIT SHFT GLAND NUT, NYLON	
11	6	763027	AGIT IMPELLER	
12	2	763360	AGIT SHAFT 280	91
13	2	763217	GLAND PACKING, 13 IN. LONG	
14	2	763357	AGIT MTR MT PLT CES 280	91
15	2	763359	AGIT MTR CPLR 280	91
16	4	900064	5/16UNC X 3/4 HEX BOLT	
17	4	900130	3/8UNC X 1 1/4 HEX BOLT	
18	4	914002	5/16UNC HEX STOVER NUT	
19	4	914004	3/8UNC HEX STOVER NUT	
20	4	920001	5/16 SAE FLAT WASHER	
21	4	920002	3/8 SAE FLAT WASHER	
22	2	470200	1/4UNC X 1 3/4 HEX BOLT SS	
23	2	763358	AGIT MTR MT YOKE CES 280	91
24	2	763361	AGIT CPLR SHIELD 280	91
25	2	900000	1/4UNC X 1/2 HEX BOLT	
26	2	914000	1/4UNC HEX STOVER NUT	

NOTE: QUANTITY LISTED IS FOR ONE MACHINE.

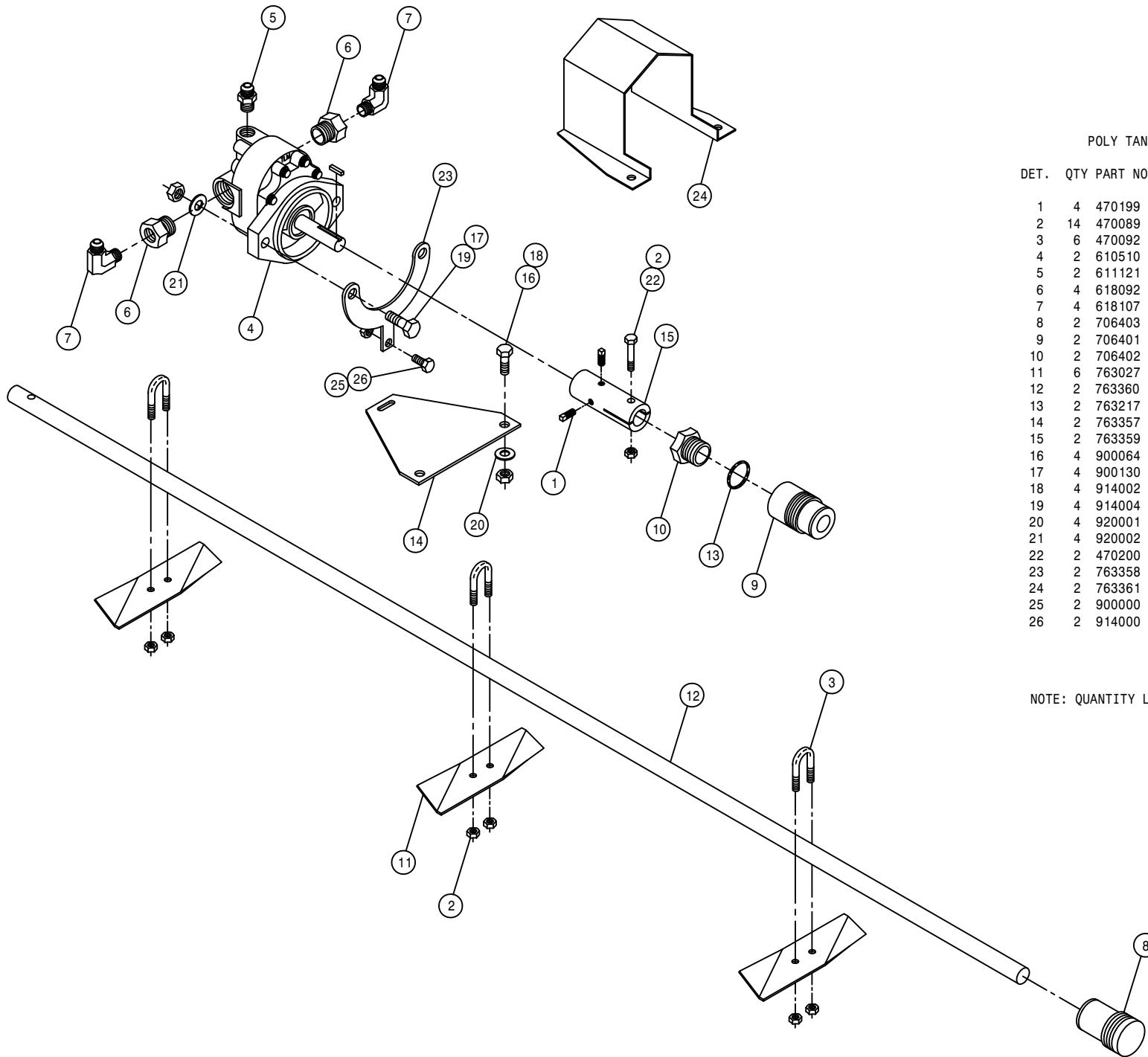

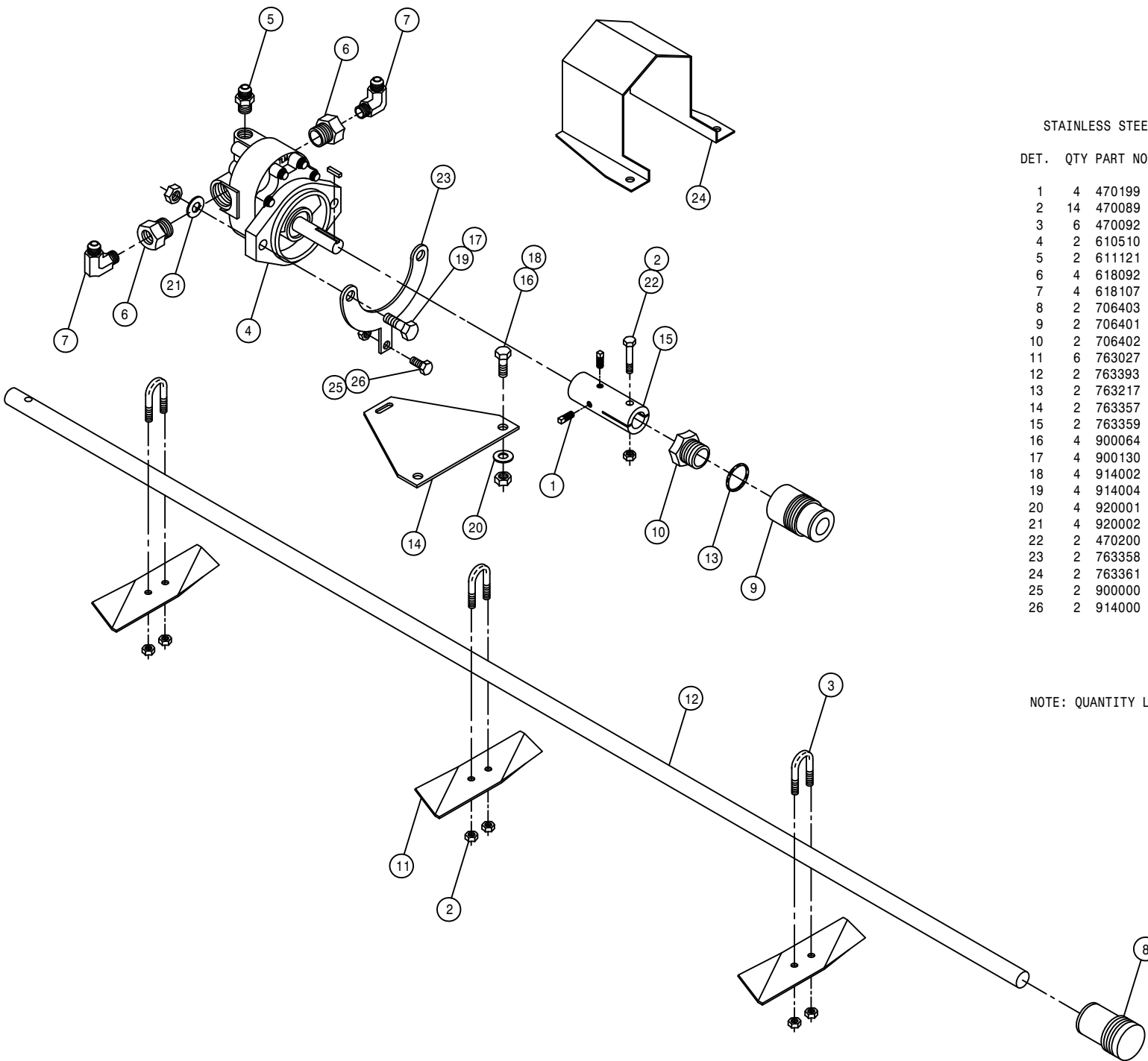

STAINLESS STEEL TANK AGITATOR ASSEMBLY

DET. QTY PART NO. DESCRIPTION

1	4	470199	1/4UNC X 3/8 SQHD CUP SET SCR	
2	14	470089	1/4UNC HEX LOC NUT NYL INS SS	
3	6	470092	1/4UNC-3/4ID-1 1/4 U-BOLT SS	
4	2	610510	CESSNA GEAR MOTOR 1.48CI	
5	2	611121	9/16MJIC-1/4MNPT ADPTR	
6	4	618092	1 1/16MOR-1/2FNPT ADPTR	
7	4	618107	9/16MJIC-90-1/2MNPT LBO	
8	2	706403	FRT AGIT SHFT BRG, NYLON	
9	2	706401	REAR AGIT SHFT BRG, NYLON	
10	2	706402	AGIT SHFT GLAND NUT, NYLON	
11	6	763027	AGIT IMPELLER	
12	2	763393	AGIT SHAFT 250	91
13	2	763217	GLAND PACKING, 13 IN. LONG	
14	2	763357	AGIT MTR MT PLT CES 280	91
15	2	763359	AGIT MTR CPLR 280	91
16	4	900064	5/16UNC X 3/4 HEX BOLT	
17	4	900130	3/8UNC X 1 1/4 HEX BOLT	
18	4	914002	5/16UNC HEX STOVER NUT	
19	4	914004	3/8UNC HEX STOVER NUT	
20	4	920001	5/16 SAE FLAT WASHER	
21	4	920002	3/8 SAE FLAT WASHER	
22	2	470200	1/4UNC X 1 3/4 HEX BOLT SS	
23	2	763358	AGIT MTR MT YOKE CES 280	91
24	2	763361	AGIT CPLR SHIELD 280	91
25	2	900000	1/4UNC X 1/2 HEX BOLT	
26	2	914000	1/4UNC HEX STOVER NUT	

NOTE: QUANTITY LISTED IS FOR ONE MACHINE.

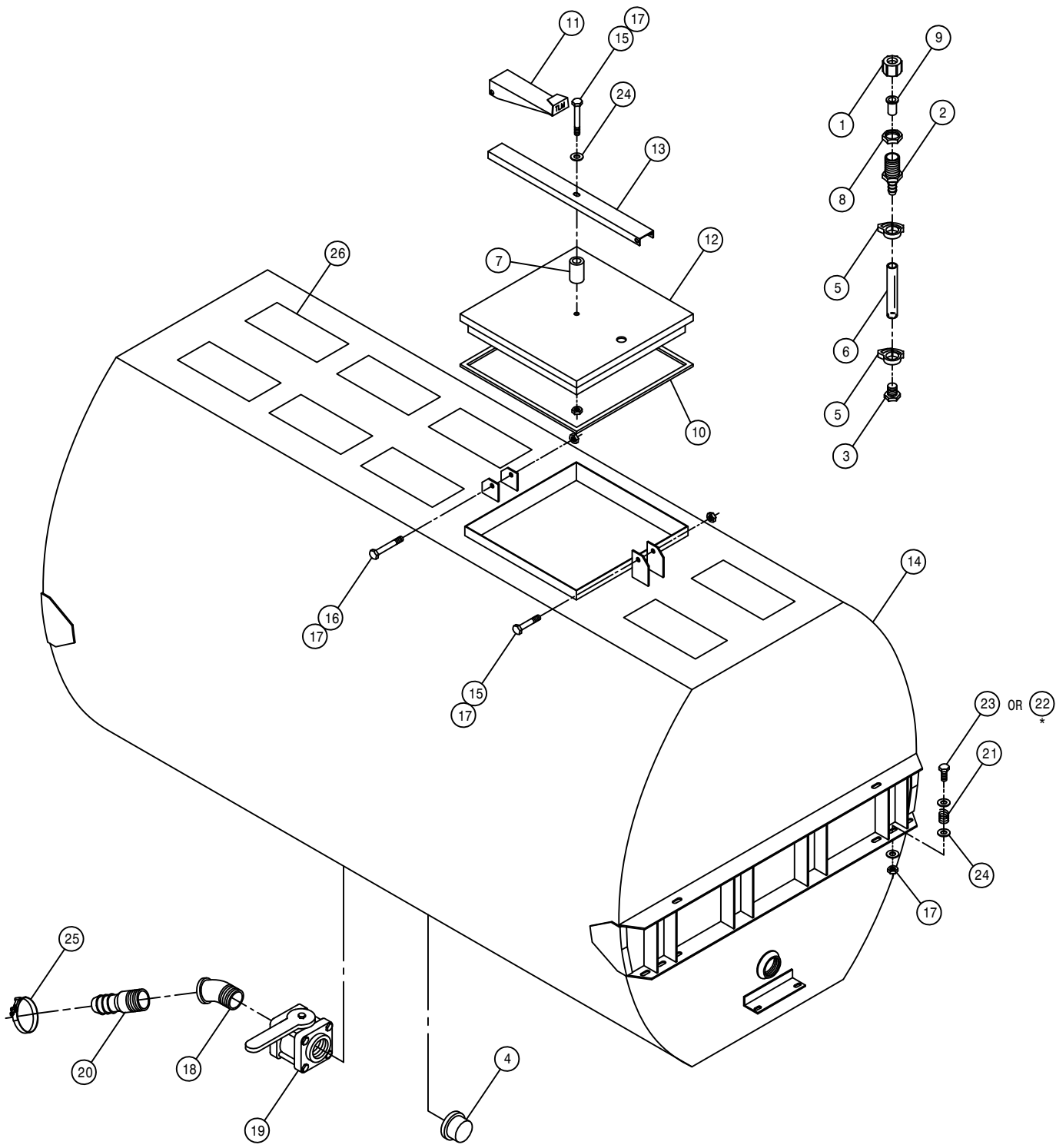

STAINLESS STEEL SOLUTION TANK ASSEMBLY

DET.	QTY	PART NO.	DESCRIPTION
1	2	500005	CAP NUT .688FPS NYLON
2	2	500006	.38 H BARB X .69 MPS NYLON
3	2	500007	FTG .12 MNPT HEX PLUG NYLON
4	2	507100	PIPE CAP 1.50NPT
5	4	520003	HOSE CLAMP NO 6 PLASTIC SNAP
6	2	601216	SPRAY TNK VENT HOSE .38X3.50
7	2	601231	HOSE, 3/4 X 2 HI PRESS EPDM
8	2	737858	TEE AND EL NUT .688 FPS
9	2	738859	STRAINER 50 MESH NYLON
10	2	760651	TANK LID GSKT 647
11	2	763163	SPRAY TANK LATCH HANDLE 647S
12	2	763164	SPRAY TANK LID WLD 647S
13	2	763166	TANK LID CHAN 647-S SIDE
14	2	763294	SS SPRAY TANK WLD 400 GAL 280
15	4	900134	3/8UNC X 2 1/2 HEX BOLT
16	2	900138	3/8UNC X 3 1/2 HEX BOLT
17	14	914004	3/8UNC HEX STOVER NUT
18	2	507024	BLK PIPE ST EL 45DEG 1.50NPT
19	2	696110	BALL VALVE 1 1/2FNPT POLY
20	2	716003	1 1/2 X 1 1/2 HOSE BARB
21	4	499001	SPRING HYDRO CONTROL
22	4	900129	3/8UNC X 1" HEX BOLT
23	4	900170	3/8UNC X 2 1/4 HEX BOLT
24	22	920002	3/8 SAE FLAT WASHER
25	2	520133	1.81/2.06 T-BOLT HOSE CLAMP
26	16	659677	4X9 SAFETY WALK

*NOTE: 1. QUANTITY LISTED IS FOR ONE MACHINE.
 2. HARDWARE SHOWN IS FOR REAR OF SOLUTION TANK.
 FRONT SIDE USES DETAIL 22 AND NO SPRINGS.

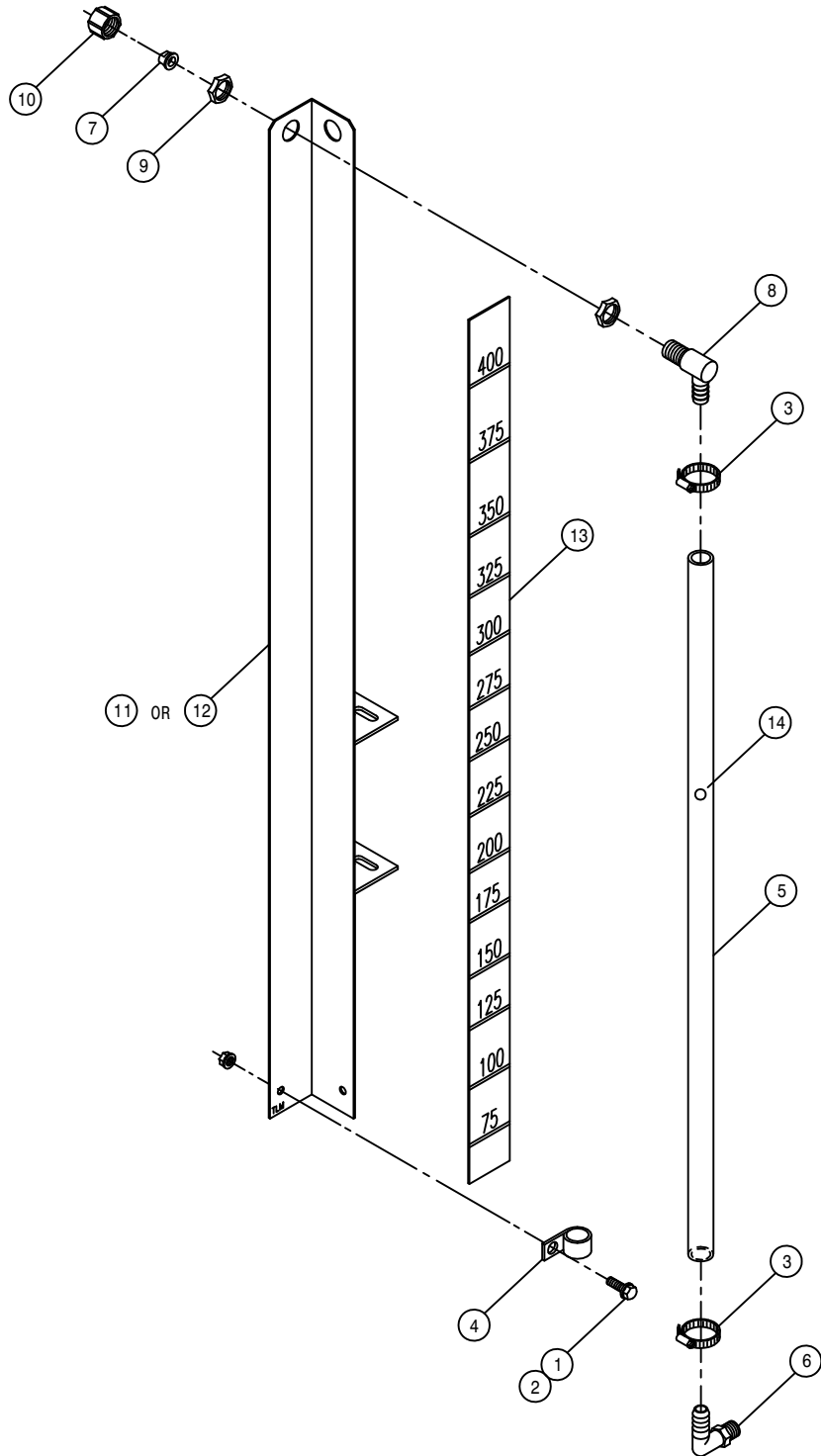

SIGHT GAUGE HOSE ASSEMBLY

DET. QTY PART NO. DESCRIPTION

1	2	470122	1/4UNC X 1/2 FLANGE HEX BOLT
2	2	470121	1/4UNC HEX FLANGE LOCK NUT
3	4	520069	HOSE CLAMP NO 6 STAINLESS
4	2	520117	CUSH HOSE CLAMP 5/8D X 1/2W
5	2	601302	HOSE, 1/2 X 52 SIGHT GAUGE
6	2	618556	1/4NPT-90-1/2 HOSE BARB,POLY
7	2	731109	TIP,FS-9 80DEG NYL SNGL ORF
8	2	737856	EL NOZL BODY .50 STEEL
9	2	737858	TEE AND EL NUT .688 FPS
10	2	738866	CAP NUT .688 FPS STEEL
11	1	763316	RH SIGHT GAUGE MT WLD 280 89
12	1	763317	LH SIGHT GAUGE MT WLD 280 89
13	2	650334	DECAL,SS TANK SIGHT GAUGE 280
14	2	763446	RED POLYPROPYLENE BALL 25/64"

NOTE: QUANTITY LISTED IS FOR ONE MACHINE.

60' BOOM SOLUTION SOLENOID ASSEMBLY

DET. QTY PART NO. DESCRIPTION

DET.	QTY	PART NO.	DESCRIPTION	
1	2	164301	SOLU VLV MANIFOLD MT	97
2	1	500014	1"NPT-90 ST EL, POLY	
3	3	500024	1"NPT-90-1"HOSE BARB, POLY	
4	1	500032	1 1/2NPT X 1 1/2 H BARB, POLY	
5	1	500048	1 1/2X1"NPT REDU NIPPLE, POLY	
6	1	690535	CONTROL VALVE, 1 1/2"POLY,RAVN	
7	1	501210	BLK PIPE CPLG .25NPT	
8	1	501605	BLK PIPE NIPPLE .25NPT-3.00	
9	1	505225	1"-1/4"NPT REDU BUSH, POLY	
10	1	690359	PRESSURE GA GLYCERI 100 PSI	
11	1	696164	SOLU VLV ASSY,3-SECT 1"NPT	
12	2	164302	SOLU VLV MANIFOLD MT KEEPER97	
13	3	520087	HOSE CLAMP NO 20 STAINLESS	
14	2	472349	1/4 X 3/4 20THD-IN TEK TYPE	
15	2	500057	2"NPT X 1 1/2 H BARB, POLY	
16	2	520056	HOSE CLAMP NO 56 STAINLESS	
17	3	520133	1.81/2.06 T-BOLT HOSE CLAMP	
18	1	601217	HOSE, 1 1/2 X 24 2F-1W EPDM	
19	1	690529	RFM 100 FLOW METER, RAVEN	
20	4	900009	1/4UNC X 2 3/4 HEX BOLT	
21	4	914000	1/4UNC HEX STOVER NUT	

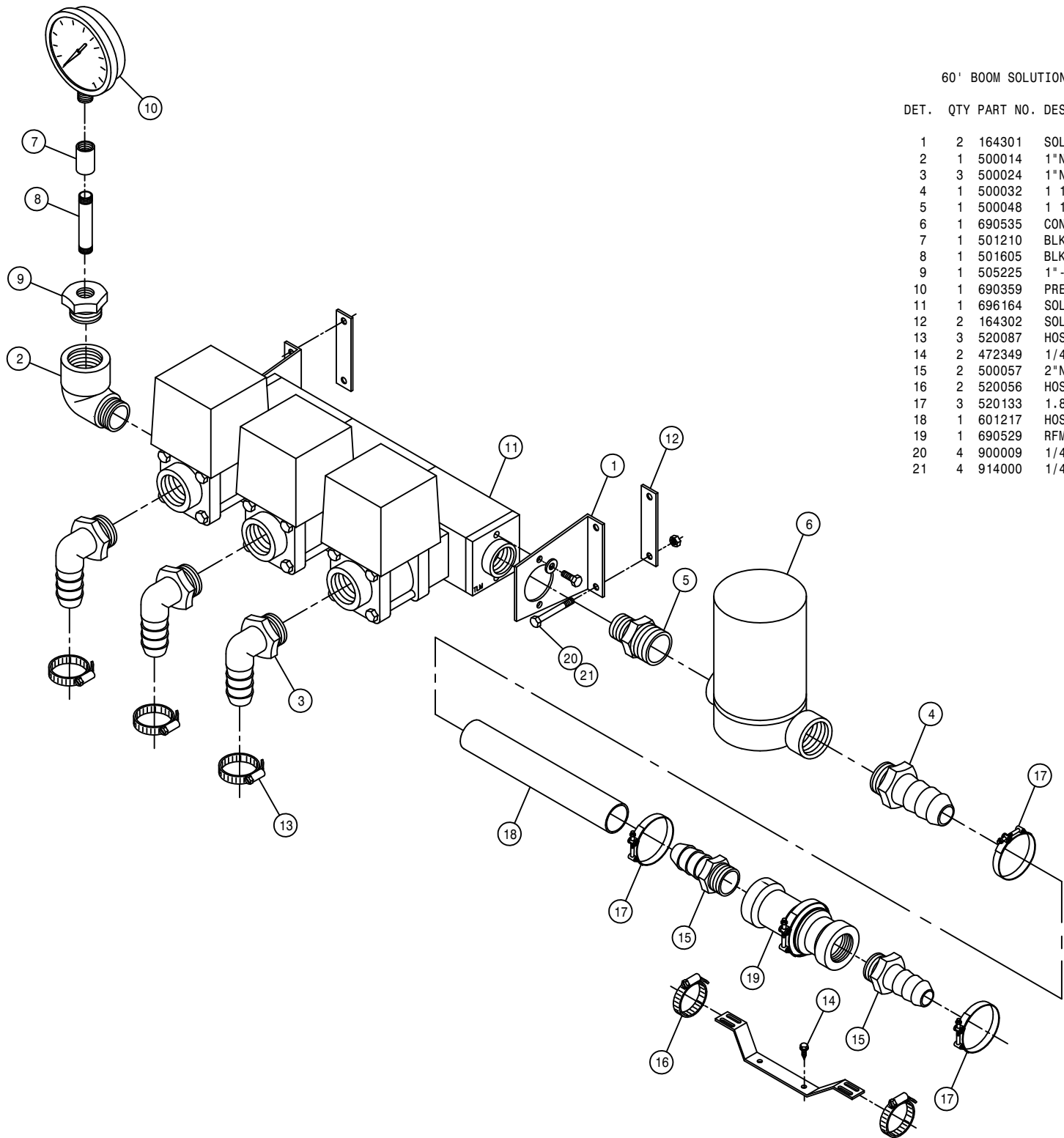

80'-90' BOOM SOLUTION SOLENOID ASSEMBLY

DET. QTY PART NO. DESCRIPTION

DET.	QTY	PART NO.	DESCRIPTION	
1	2	164301	SOLU VLV MANIFOLD MT	97
2	2	500013	1"NPT HEX PIPE NIPPLE, POLY	
3	5	500024	1"NPT-90-1"HOSE BARB, POLY	
4	1	500032	1 1/2"NPT X 1 1/2 H BARB, POLY	
5	1	500048	1 1/2X1"NPT REDU NIPPLE, POLY	
6	1	690535	CONTROL VALVE,1 1/2"POLY,RAVN	
7	1	501210	BLK PIPE CPLG .25NPT	
8	1	501605	BLK PIPE NIPPLE .25NPT-3.00	
9	1	505225	1"-1/4"NPT REDU BUSH, POLY	
10	1	690359	PRESSURE GA GLYCERI 100 PSI	
11	1	696164	SOLU VLV ASSY,3-SECT 1"NPT	
12	2	164302	SOLU VLV MANIFOLD MT KEEPER97	
13	5	520087	HOSE CLAMP NO 20 STAINLESS	
14	2	472349	1/4 X 3/4 20THD-IN TEK TYPE	
15	2	500057	2"NPT X 1 1/2 H BARB, POLY	
16	2	520056	HOSE CLAMP NO 56 STAINLESS	
17	3	520133	1.81/2.06 T-BOLT HOSE CLAMP	
18	1	601217	HOSE, 1 1/2 X 24 2F-1W EPDM	
19	1	690529	RFM 100 FLOW METER, RAVEN	
20	4	900009	1/4UNC X 2 3/4 HEX BOLT	
21	4	914000	1/4UNC HEX STOVER NUT	
22	2	500075	1" NPT PIPE TEE, POLY	

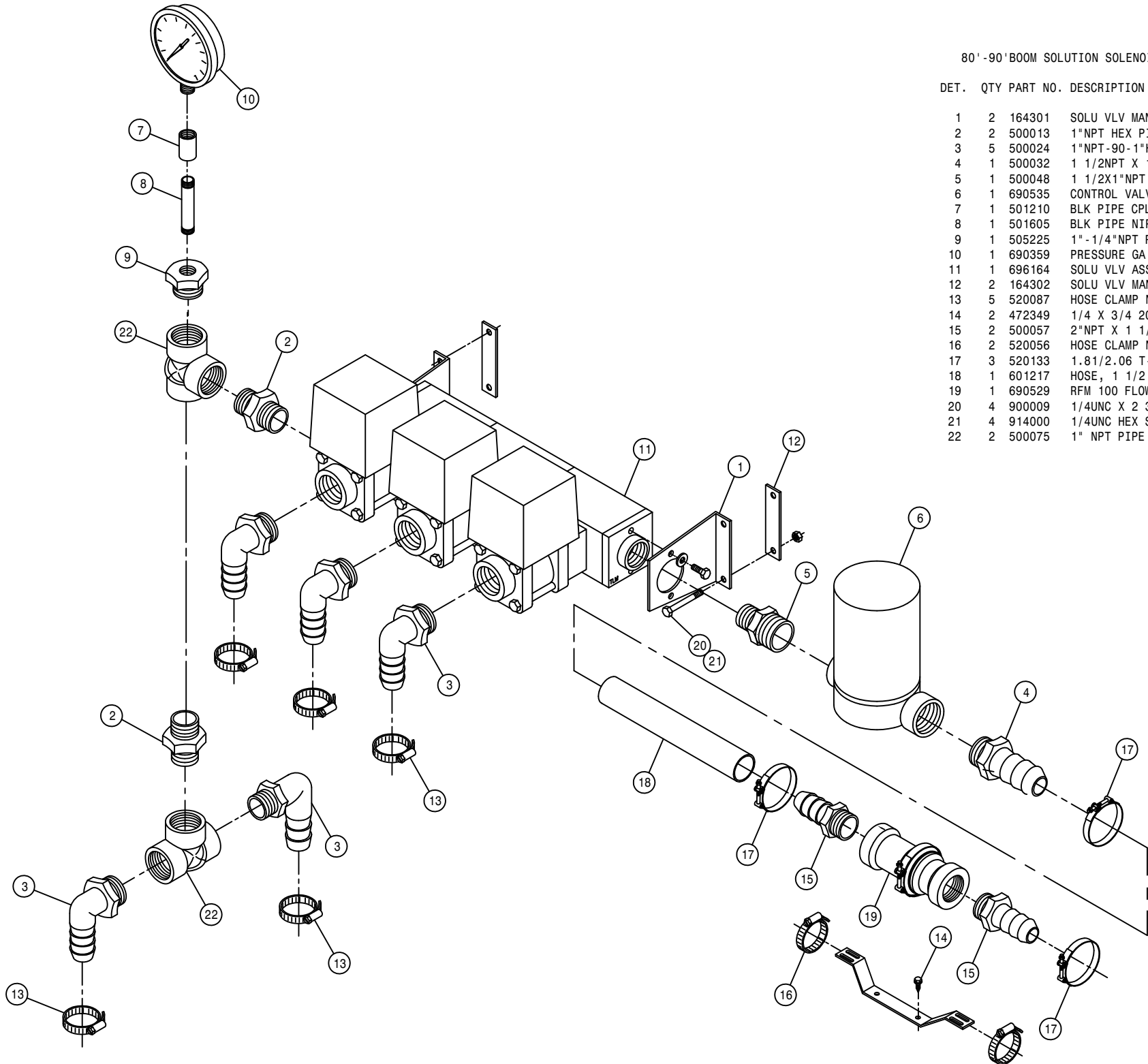

80' -90' OUTER BOOM SOLUTION SOLENOID

DET. QTY PART NO. DESCRIPTION

1	2	164303	SOLU VLV MT	97
2	2	164304	SOLU VLV MT KEEPER	97
3	2	500024	1"NPT-90-1"HOSE BARB, POLY	
4	2	500074	1"NPT-1" HOSE BARB, POLY	
5	2	696162	1" ELECT BALL VLV, 344AEC-2-1	
6	4	900007	1/4UNC X 2" HEX BOLT	
7	4	914000	1/4UNC HEX STOVER NUT	
8	4	520087	HOSE CLAMP NO 20 STAINLESS	

NOTE: QUANTITY LISTED IS FOR ONE MACHINE.

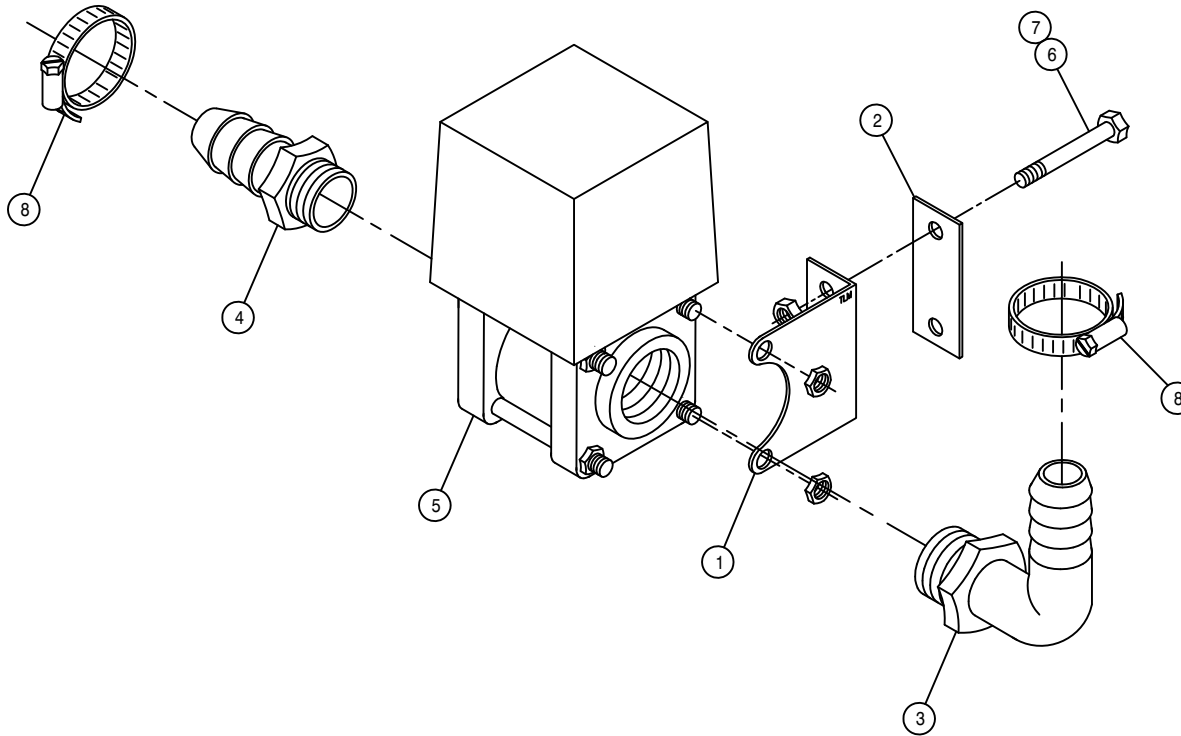

BOOM FEEDER TEE ASSEMBLY

DET. QTY PART NO. DESCRIPTION

1	1	160015	2.06ID GROMMET SLIT
2	1	160986	CHAIN, 12.00 LONG
3	1	164262	FEEDER T MTG BRKT 96
4	1	696204	QUICK CONNECT PLUG, 3/4
5	1	900002	1/4UNC X 3/4 HEX BOLT
6	5	914000	1/4UNC HEX STOVER NUT
7	2	470237	1/4UNC-1 1/2ID-3 1/4 U-BOLT
8	2	500022	3/4NPT-3/4HOSE BARB, POLY
9	1	505218	3/4 NPT PIPE TEE, POLY
10	1	737817	NOZL MT CLMP,1.00 SQ SS,Q-TJET
11	2	520055	HOSE CLAMP NO 12 STAINLESS
12	1	696203	QUICK CONNECT CPLR MALE 3/4
13	1	520087	HOSE CLAMP NO 20 STAINLESS
14	1	500026	3/4NPT-90-1"HOSE BARB, POLY
15	1	696202	QUICK CONNECT FEM ADPTR 3/4NP
16	1	737822	QUICK TEEJET CAP YELLOW 19115
17	1	737829	QUICK TJET EL BODY DIAPH .75
18	1	737830	QUICK TJET TEE BODY DIAPH .75
19	1	737832	NOZL MT CLMP,1.25 SQ,SS Q-TJET

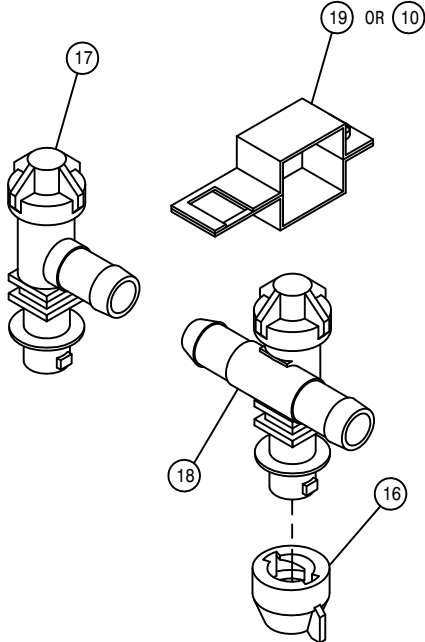
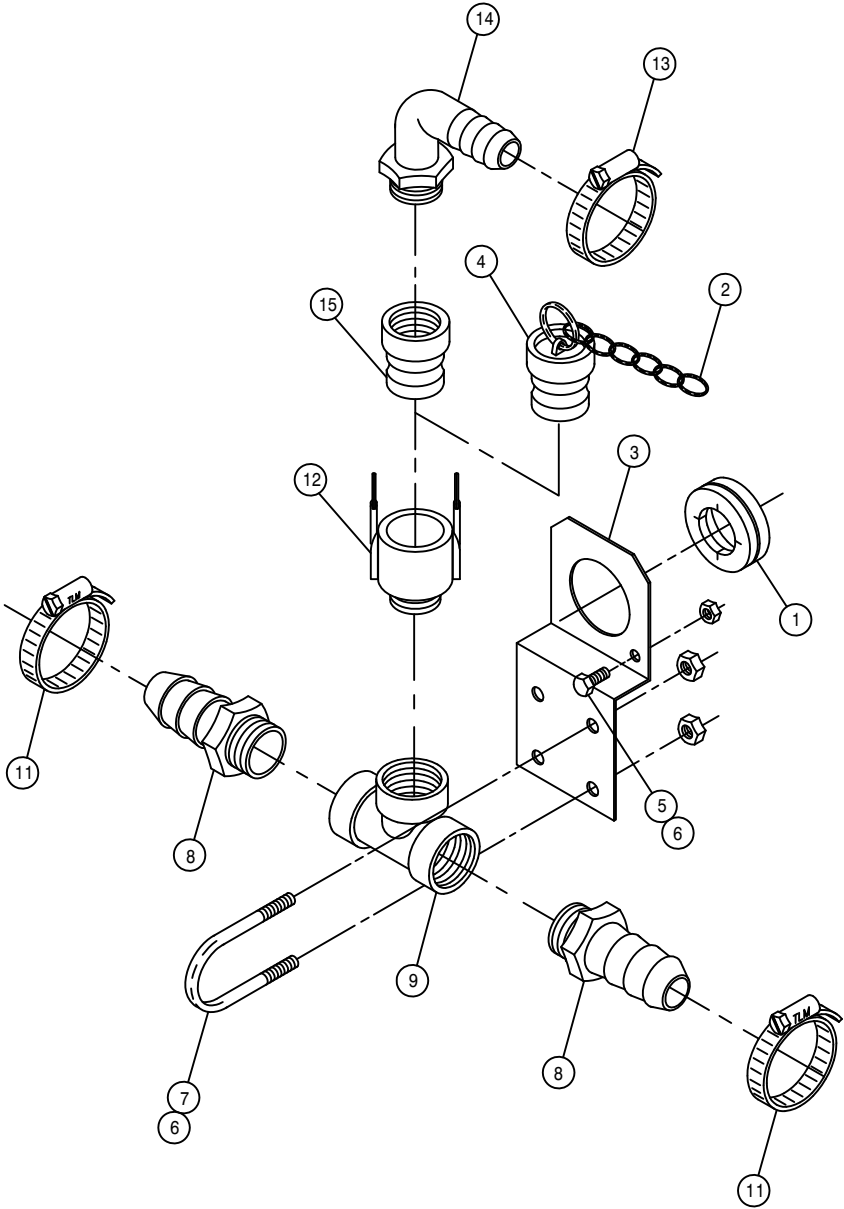

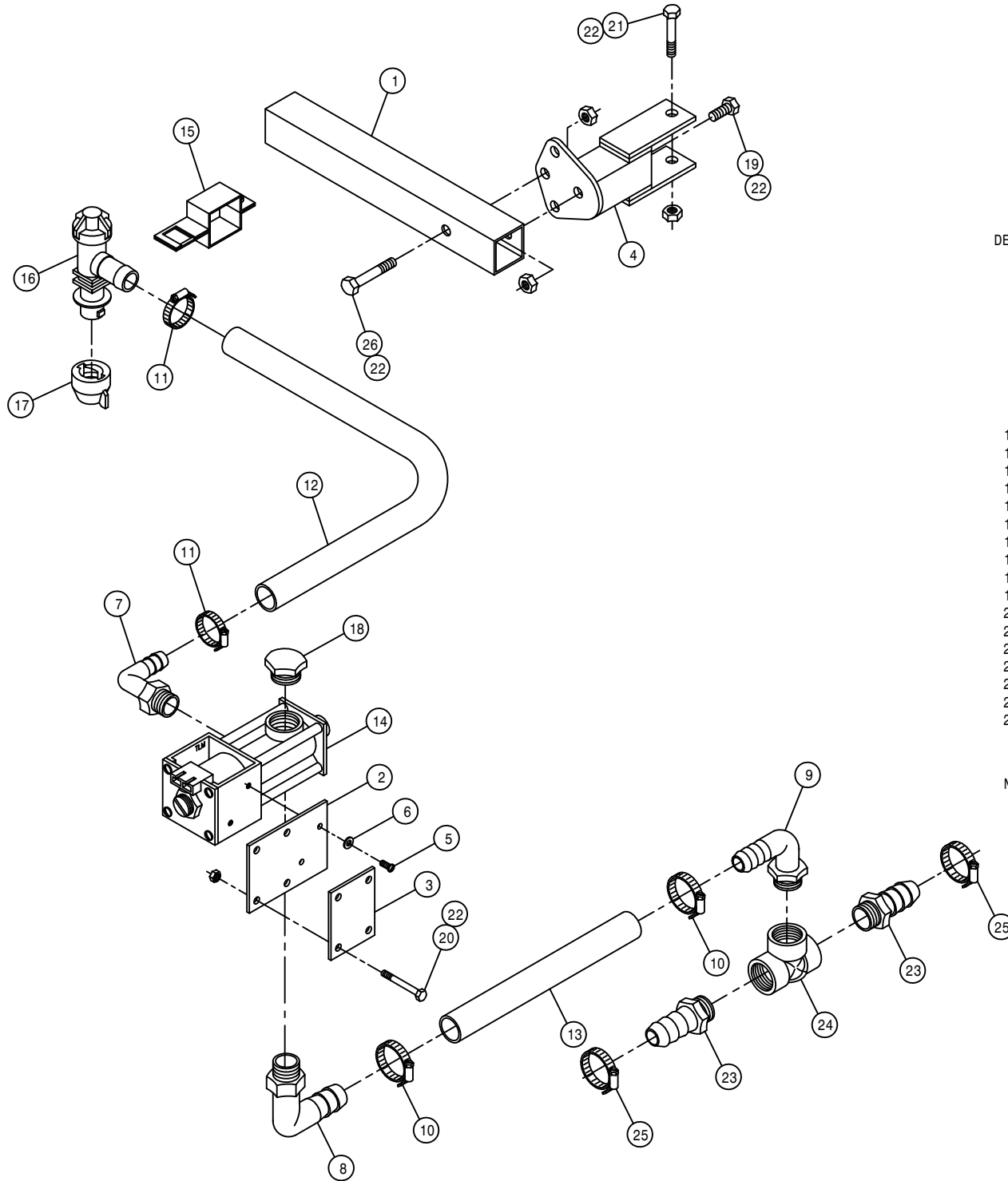

60' BOOM FENCE ROW OPTION

DET. QTY PART NO. DESCRIPTION

DET.	QTY	PART NO.	DESCRIPTION
1	2	164384	FENCE ROW NOZL MTG TUBE 98
2	2	164397	VLV MT, 60' FENCE ROW NOZL 98
3	2	164398	VLV MT KPR,60' FENCE ROW NOZL98
4	2	164399	NOZL MT WLD,60' FENCE ROW210098
5	4	472199	10-24 X 1/2 RD HD MACH SCR
6	4	473821	#10 INT TOOTH WASHER
7	2	500047	1/2NPT-90-1/2 HOSE BARB, POLY
8	2	500054	3/4NPT-90-3/4 HOSE BARB, POLY
9	2	500067	1 NPT-90-3/4 HOSE BARB, POLY
10	4	520055	HOSE CLAMP NO 12 STAINLESS
11	4	520070	HOSE CLAMP NO 8 STAINLESS
12	2	601164	HOSE, 1/2 X 117 1BR BLK EPDM
13	2	601173	HOSE, 3/4 X 50 1BR BLK EPDM
14	2	695952	SOLUTION VALVE, AA144-1 VITON
15	2	737817	NOZL MT CLMP,1.00 SQ SS,Q-TJET
16	2	737827	QUICK TEEJET CHK VLV 1/2 SNGL
17	2	737822	QUICK TEEJET CAP YELLOW 19115
18	2	500043	3/4NPT PIPE PLUG, POLY
19	2	900002	1/4UNC X 3/4 HEX BOLT
20	8	900006	1/4UNC X 1 3/4 HEX BOLT
21	2	900007	1/4UNC X 2" HEX BOLT
22	14	914000	1/4UNC HEX STOVER NUT
23	4	500074	1"NPT-1" HOSE BARB, POLY
24	2	500075	1" NPT PIPE TEE, POLY
25	4	520087	HOSE CLAMP NO 20 STAINLESS
26	2	900005	1/4UNC X 1 1/2 HEX BOLT

NOTE: QUANTITY LISTED IS FOR ONE MACHINE.

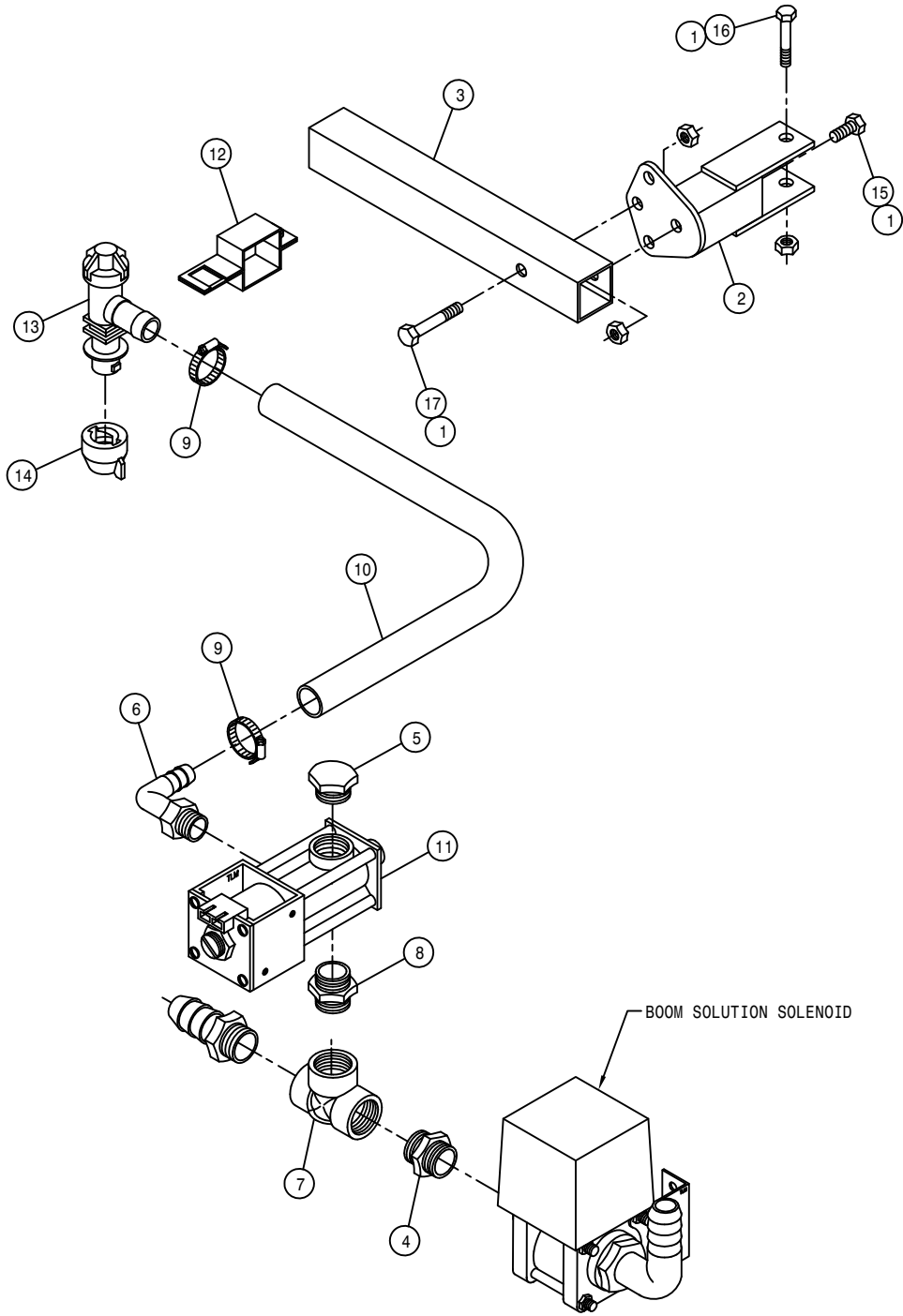

80'-90' BOOM FENCE ROW OPTION

DET. QTY PART NO. DESCRIPTION

1	6	914000	1/4UNC HEX STOVER NUT
2	2	164380	NOZL MT WLD,80/90 FENCE ROW 98
3	2	164384	FENCE ROW NOZL MTG TUBE 98
4	2	500013	1"NPT HEX PIPE NIPPLE, POLY
5	5	500043	3/4NPT PIPE PLUG, POLY
6	2	500047	1/2NPT-90-1/2 HOSE BARB, POLY
7	2	500075	1" NPT PIPE TEE, POLY
8	2	500085	1" X 3/4NPT REDU NIPPLE, POLY
9	4	520070	HOSE CLAMP NO 8 STAINLESS
10	2	601167	HOSE, 1/2 X 300 1BR BLK EPD
11	2	695952	SOLUTION VALVE, AA144-1 VITON
12	2	737817	NOZL MT CLMP,1.00 SQ SS,Q-TJET
13	2	737827	QUICK TEEJET CHK VLV 1/2 SNGL
14	2	737822	QUICK TEEJET CAP YELLOW 19115
15	2	900002	1/4UNC X 3/4 HEX BOLT
16	2	900006	1/4UNC X 1 3/4 HEX BOLT
17	2	900005	1/4UNC X 1 1/2 HEX BOLT

NOTE: QUANTITY LISTED IS FOR ONE MACHINE.

BOOM SOLUTION SOLENOID

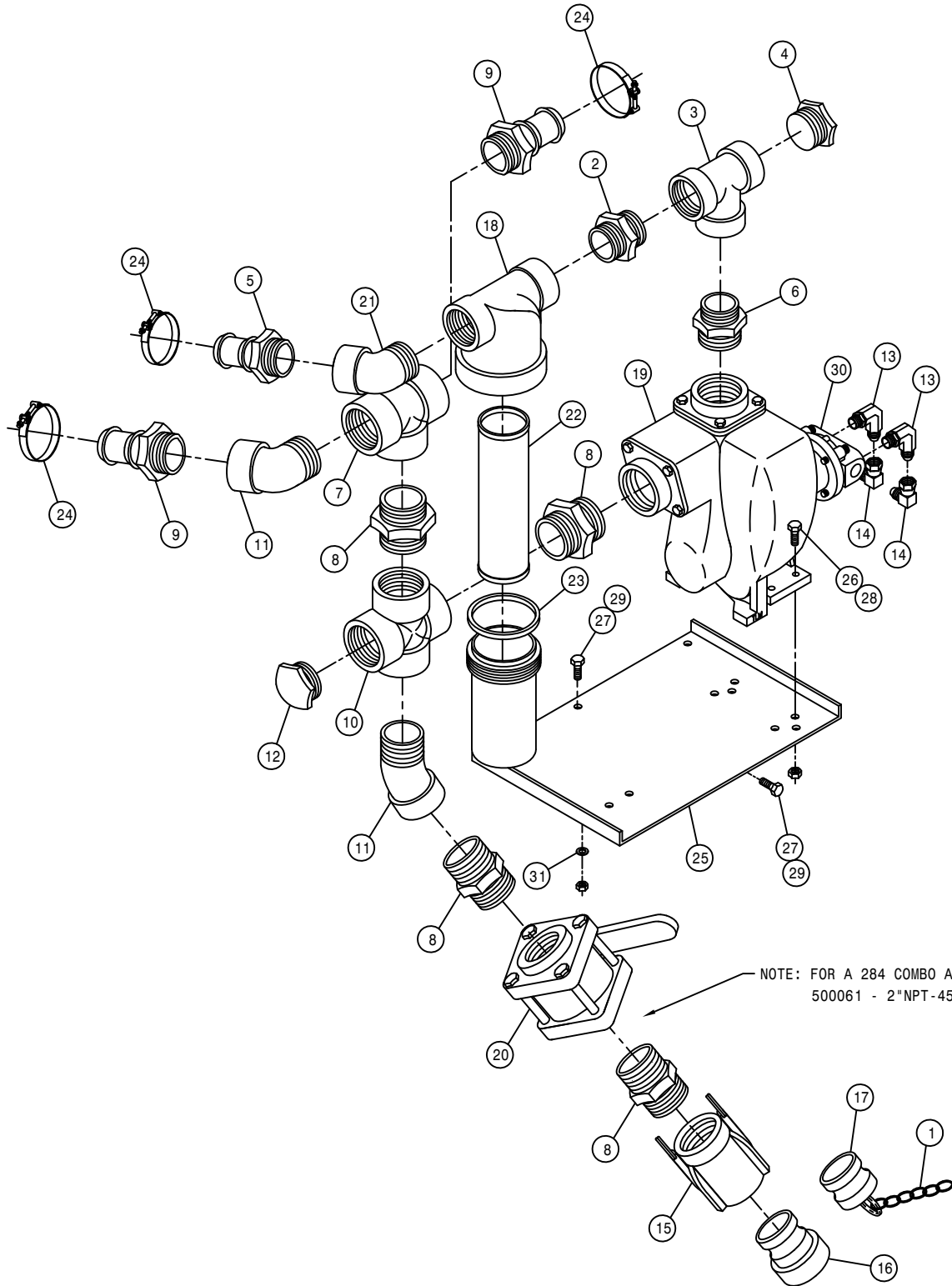

FLOMAX SOLUTION PUMP ASSEMBLY

DET.	QTY	PART NO.	DESCRIPTION
	1	160986	CHAIN, 12.00 LONG
	2	500028	1 1/2NPT PIPE NIPPLE, POLY
	3	500030	1 1/2"NPT PIPE TEE, POLY
	4	500031	1 1/2NPT PIPE PLUG, POLY
	5	500032	1 1/2NPT X 1 1/2 H BARB, POLY
	6	500038	2" X 1 1/2NPT REDU NIPPLE, POLY
	7	500055	2" NPT PIPE TEE, POLY
	8	500056	2" NPT CLOSE HEX NIPPLE, POLY
	9	500057	2"NPT X 1 1/2 H BARB, POLY
	10	500060	2"FNPT CROSS, POLY
	11	500061	2"NPT-45 ST EL, POLY
	12	500065	2"NPT PIPE PLUG, POLY
	13	618241	3/4MJIC-90-3/4MOR LBO
	14	618609	3/4MJIC-90-3/4FJIC SWIV LBO
	15	690390	2.00 FEMALE NPT COUPLER
	16	690391	2.00 FEMALE NPT ADPTR
	17	690392	ADPTR PLG FOR 2.00 NPT COUPLR
	18	690474	1 1/2 LINE STRAINER50M 150PSI
	19	690552	FLOMAX 8, 2" PUMP
	20	696134	BALL VALVE 2IN FNPT POLY
	21	500035	1 1/2NPT-45 ST EL, POLY
	22	690475	50 MESH SCREEN FOR 690474
	23	690476	STRAINER GASKET FOR 690474
	24	520133	1.81/2.06 T-BOLT HOSE CLAMP
	25	690530	2" SOLU PUMP MT WLD 95
	26	900066	5/16UNC X 1 1/4 HEX BOLT
	27	900129	3/8UNC X 1" HEX BOLT
	28	914002	5/16UNC HEX STOVER NUT
	29	914004	3/8UNC HEX STOVER NUT
	30	690573	HYD MOTOR, FLOMAX HI-SPEED
	31	920002	3/8 SAE FLAT WASHER

NOTE: FOR A 284 COMBO ADD FITTING
500061 - 2"NPT-45 ST EL POLY

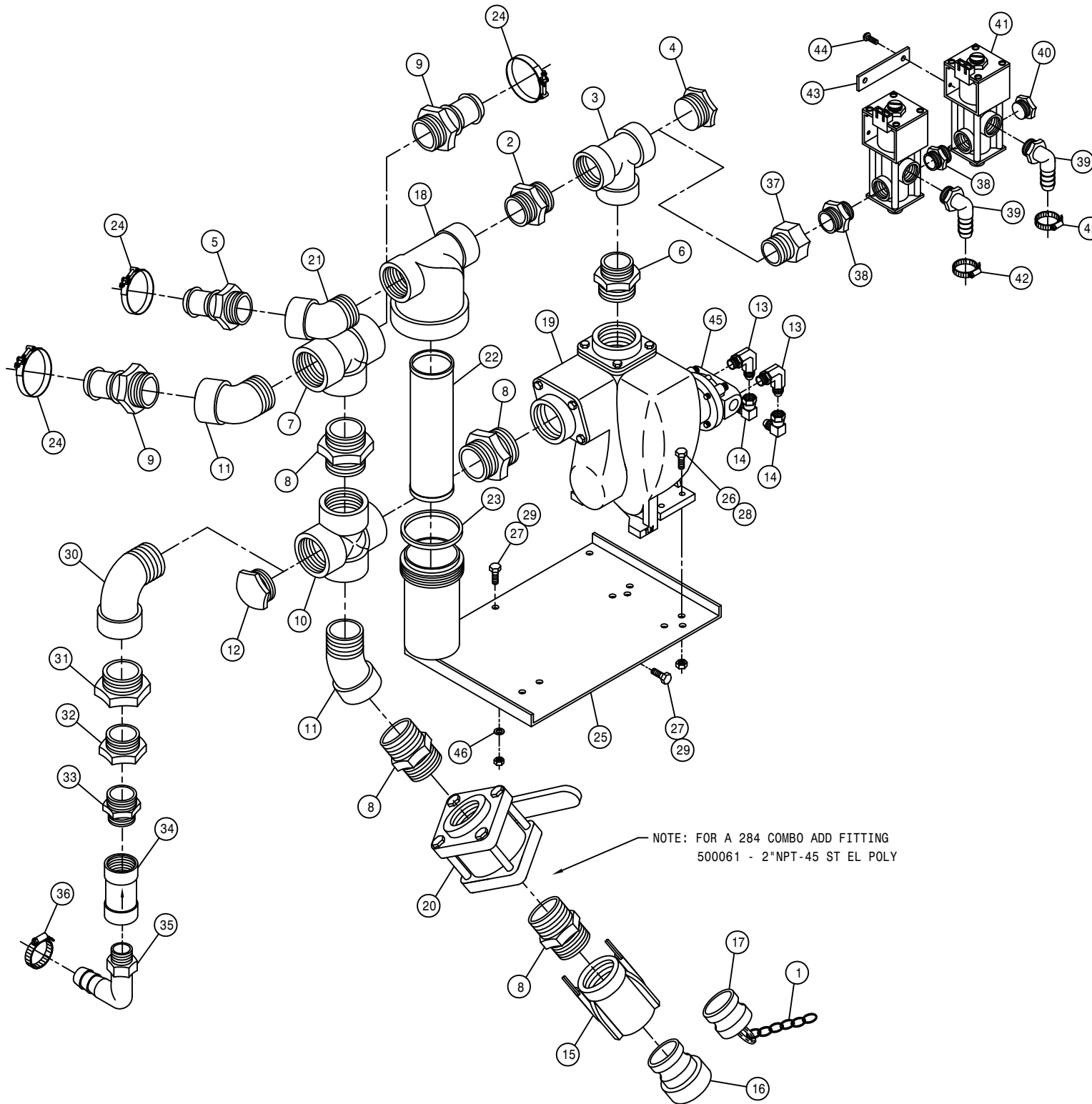

FLOMAX SOLUTION PUMP ASSEMBLY WITH RINSE

DET. QTY PART NO. DESCRIPTION

1	1	160986	CHAIN, 12.00 LONG
2	1	500028	1 1/2NPT PIPE NIPPLE, POLY
3	1	500030	1 1/2" NPT PIPE TEE, POLY
4	1	500031	1 1/2NPT PIPE PLUG, POLY
5	1	500032	1 1/2NPT X 1 1/2 H BARB, POLY
6	1	500038	2" X 1 1/2NPT REDU NIPPLE, POLY
7	1	500055	2" NPT PIPE TEE, POLY
8	4	500056	2" NPT CLOSE HEX NIPPLE, POLY
9	2	500057	2" NPT X 1 1/2 H BARB, POLY
10	1	500060	2" FNPT CROSS, POLY
11	2	500061	2" NPT-45 ST EL, POLY
12	1	500065	2" NPT PIPE PLUG, POLY
13	2	618241	3/4MJIC-90-3/4MOR LBO
14	2	618609	3/4MJIC-90-3/4FJIC SWIV LBO
15	1	690390	2.00 FEMALE NPT COUPLER
16	1	690391	2.00 FEMALE NPT ADPTR
17	1	690392	ADPTR PLG FOR 2.00 NPT COUPLR
18	1	690474	1 1/2 LINE STRAINER 50M 150PSI
19	1	690552	FLOMAX 8, 2" PUMP
20	1	696134	BALL VALVE 2IN FNPT POLY
21	1	500035	1 1/2NPT-45 ST EL, POLY
22	1	690475	50 MESH SCREEN FOR 690474
23	1	690476	STRAINER GASKET FOR 690474
24	3	520133	1.81/2.06 T-BOLT HOSE CLAMP
25	1	690530	2" SOLU PUMP MT WLD 95
26	4	900066	5/16UNC X 1 1/4 HEX BOLT
27	3	900129	3/8UNC X 1" HEX BOLT
28	4	914002	5/16UNC HEX STOVER NUT
29	3	914004	3/8UNC HEX STOVER NUT
30	1	500053	2" NPT-90 ST EL, POLY
31	1	500071	2" X 1 1/2NPT REDU BUSH, POLY
32	1	500037	1 1/2" X 1 1/4NPT BUSH, POLY
33	1	500052	1 1/4 X 1NPT REDU NIPPLE, POLY
34	1	690488	1.00 CHECK VLV, SPRING LOADED
35	1	500024	1" NPT-90-1" HOSE BARB, POLY
36	1	520087	HOSE CLAMP NO 20 STAINLESS
37	1	500040	1 1/2 X 3/4 NPT BUSH, POLY
38	2	690098	3/4NPT CLOSE NIPPLE, POLY
39	2	500047	1/2NPT-90-1/2 HOSE BARB, POLY
40	1	500043	3/4NPT PIPE PLUG, POLY
41	2	695952	SOLUTION VALVE, AA144-1 VITON
42	2	520070	HOSE CLAMP NO 8 STAINLESS
43	1	342014	SOLENOID KEEPER, RINSE SYS
44	2	472199	10-24 X 1/2 RD HD MACH SCR
45	1	690573	HYD MOTOR, FLOMAX HI-SPEED
46	2	920002	3/8 SAE FLAT WASHER

NOTE: FOR A 284 COMBO ADD FITTING
500061 - 2" NPT-45 ST EL POLY

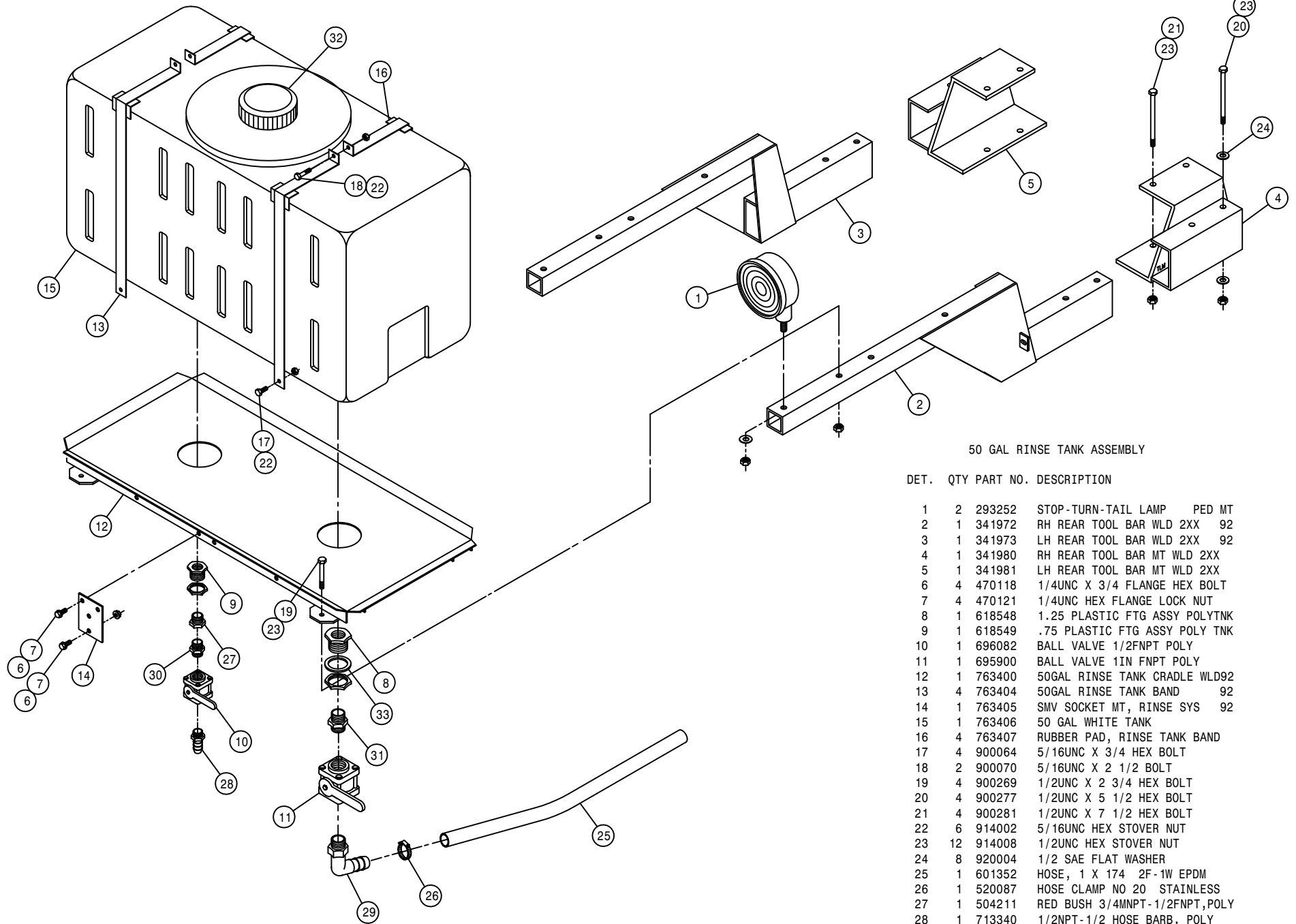

50 GAL RINSE TANK ASSEMBLY

DET.	QTY	PART NO.	DESCRIPTION
	1	2	293252 STOP-TURN-TAIL LAMP PED MT
	2	1	341972 RH REAR TOOL BAR WLD 2XX 92
	3	1	341973 LH REAR TOOL BAR WLD 2XX 92
	4	1	341980 RH REAR TOOL BAR MT WLD 2XX
	5	1	341981 LH REAR TOOL BAR MT WLD 2XX
	6	4	470118 1/4UNC X 3/4 FLANGE HEX BOLT
	7	4	470121 1/4UNC HEX FLANGE LOCK NUT
	8	1	618548 1.25 PLASTIC FTG ASSY POLYTNK
	9	1	618549 .75 PLASTIC FTG ASSY POLY TNK
	10	1	696082 BALL VALVE 1/2FNPT POLY
	11	1	695900 BALL VALVE 1IN FNPT POLY
	12	1	763400 50GAL RINSE TANK CRADLE WLD92
	13	4	763404 50GAL RINSE TANK BAND 92
	14	1	763405 SMV SOCKET MT, RINSE SYS 92
	15	1	763406 50 GAL WHITE TANK
	16	4	763407 RUBBER PAD, RINSE TANK BAND
	17	4	900064 5/16UNC X 3/4 HEX BOLT
	18	2	900070 5/16UNC X 2 1/2 BOLT
	19	4	900269 1/2UNC X 2 3/4 HEX BOLT
	20	4	900277 1/2UNC X 5 1/2 HEX BOLT
	21	4	900281 1/2UNC X 7 1/2 HEX BOLT
	22	6	914002 5/16UNC HEX STOVER NUT
	23	12	914008 1/2UNC HEX STOVER NUT
	24	8	920004 1/2 SAE FLAT WASHER
	25	1	601352 HOSE, 1 X 174 2F-1W EPDM
	26	1	520087 HOSE CLAMP NO 20 STAINLESS
	27	1	504211 RED BUSH 3/4MNPT-1/2FNPT,POLY
	28	1	713340 1/2NPT-1/2 HOSE BARB, POLY
	29	1	500024 1"NPT-90-1"HOSE BARB, POLY
	30	1	503101 1/2NPT CLOSE NIPPLE, POLY
	31	1	500052 1 1/4 X 1NPT REDU NIPPLE,POLY
	32	1	690511 LID, RAVEN RINSE TANK 763406
	33	1	763430 1 1/4 TANK FLANGE RUBBER SEAL

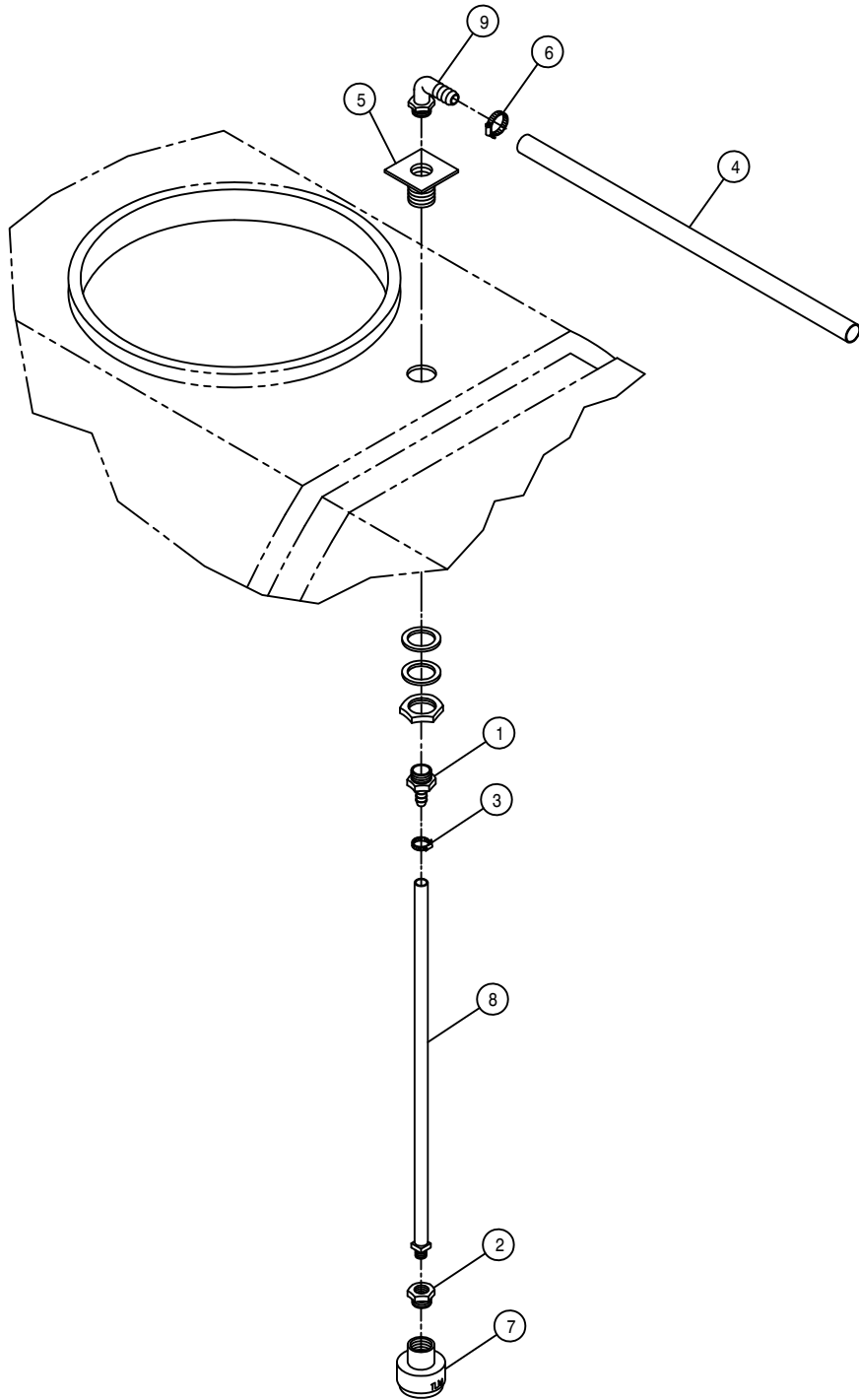

RINSE NOZZLE ASSEMBLY

DET. QTY PART NO. DESCRIPTION

1	2	500027	3/4NPT-3/8 HOSE BARB, POLY
2	2	504002	RED BUSH 3/4 TO 1/4, POLY
3	2	520120	HOSE CLAMP NO 4 STAINLESS
4	2	601164	HOSE, 1/2 X 117 1BR BLK EPDM
5	2	618549	.75 PLASTIC FTG ASSY POLY TNK
6	2	520070	HOSE CLAMP NO 8 STAINLESS
7	2	737873	ROTARY NOZZLE, TEFLON
8	2	737821	QUICK TEEJET HOSE DROP 24IN
9	2	500041	3/4NPT-90-1/2"HOSE BARB, POLY

NOTE: QUANTITY LISTED IS FOR ONE MACHINE.

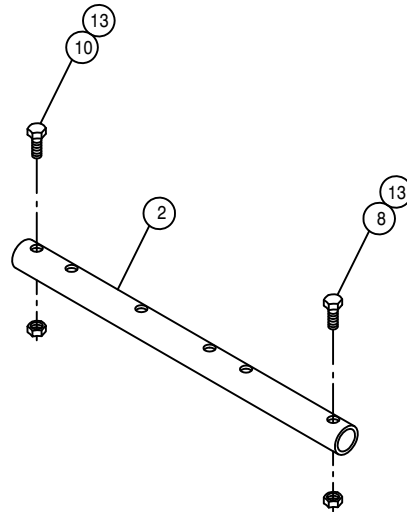
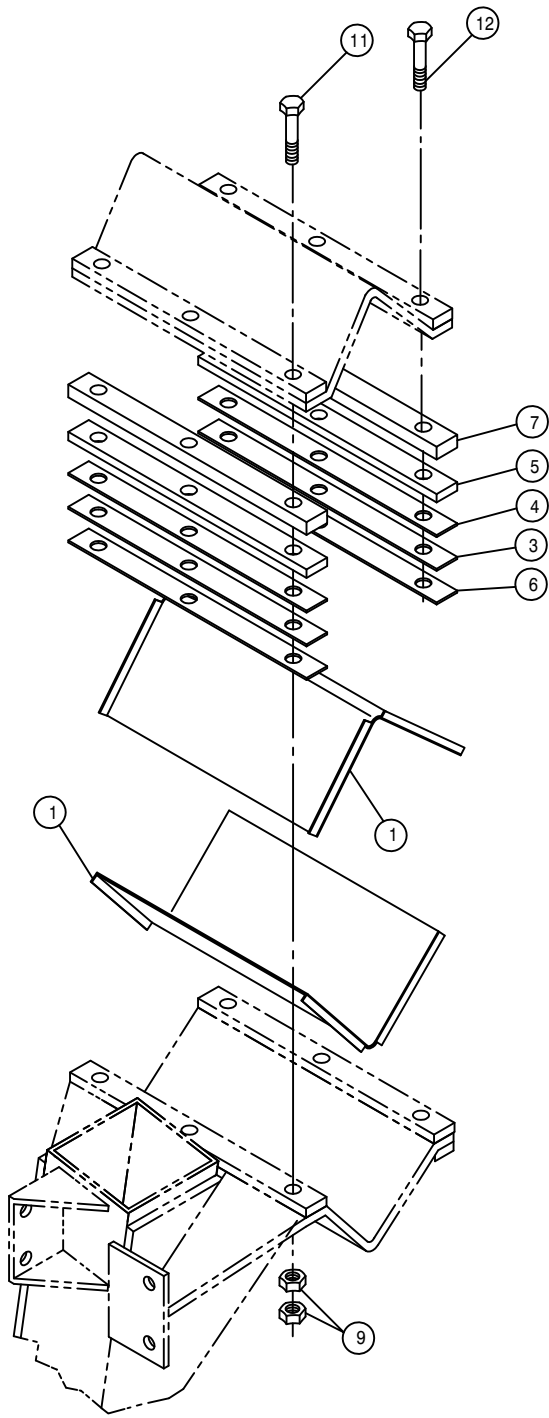

TREAD ADJUSTMENT ASSEMBLY

DET. QTY PART NO. DESCRIPTION

1	8	358703	TREAD ADJ XMBR BEARING ASSY	
2	4	358747	TREAD ADJ CYL EXT TUBE	94
3	8	358767	.025 LEG MT SHIM, 284T	94
4	8	358752	.074 LEG MT SHIM, 284T	94
5	8	358769	.250 LEG MT SHIM, 284T	94
6	8	358768	.037 LEG MT SHIM, 284T	94
7	8	358766	.375 LEG MT SPACER, 284T	94
8	4	900268	1/2UNC X 2 1/2 HEX BOLT	
9	48	914811	5/8UNF HEX NUT GR8	
10	4	900267	1/2UNC X 2" HEX BOLT	
11	12	900837	5/8UNF X 3 1/2 HEX BOLT GR8	
12	12	900838	5/8UNF X 4" HEX BOLT GR8	
13	8	914008	1/2UNC HEX STOVER NUT	

NOTE: QUANTITY LISTED IS FOR ONE MACHINE.

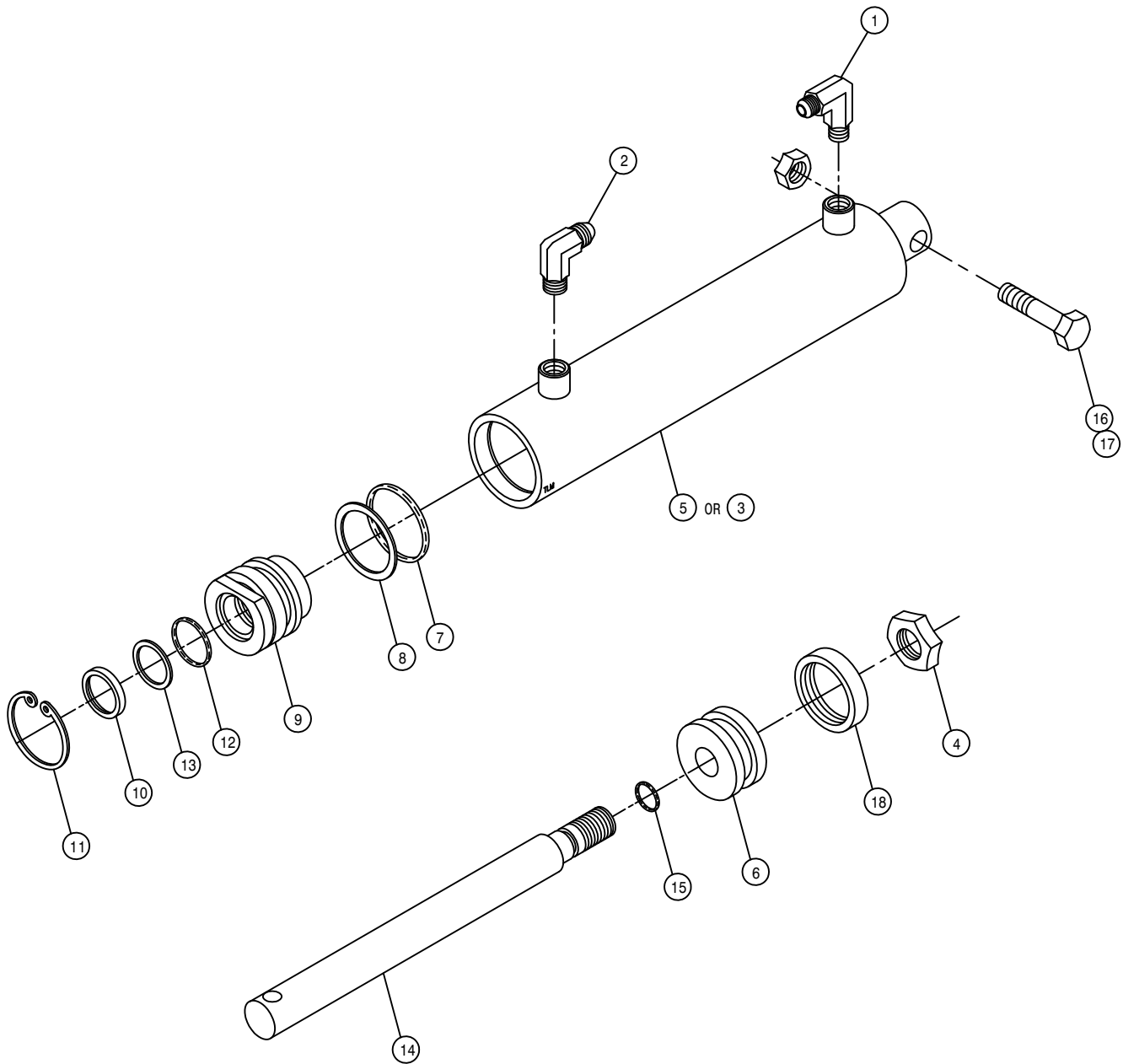

TREAD ADJUSTMENT LEG CYLINDER ASSEMBLY

DET.	QTY	PART NO.	DESCRIPTION
1	1	614710	RESTRICTOR ELBOW ASSY .025DIA
2	1	611122	9/16MJIC-90-1/4MNPT LBO
3	1	620119	LH CYL TUBE WLD,LEG,TREAD ADJ
4	1	472297	3/4UNF HEX STOVER NUT THIN
5	1	620118	RH CYL TUBE WLD,LEG,TREAD ADJ
6	1	620081	PISTON 2 X 1 ZAMAC ORING TYPE
7	1	870326	BUNA ORING 1 5/8 X 2
8	1	890326	BACKUP WASH 1 5/8 X 2 LEATH
9	1	620082	GLAND 2 IN X 1 IN ZAMAC
10	1	629003	WIPER 1 X 1 1/4 X 1/8
11	1	629505	SNAP RING 2 IN INTRN
12	1	870214	BUNA ORING 1 X 1 1/4
13	1	890214	BACKUP WASH 1 X 1 1/4 HT2022
14	1	620111	TREAD ADJ HYD LEG CYL SHAFT
15	1	870113	BUNA ORING 9/16 X 3/4
16	1	900268	1/2UNC X 2 1/2 HEX BOLT
17	1	914008	1/2UNC HEX STOVER NUT
18	1	860326	CROWN SEAL, 2" PISTON, HYD

NOTE: 1. 620120 - RH LEG TREAD ADJ CYLINDER ASSEMBLY
 2. 620121 - LH LEG TREAD ADJ CYLINDER ASSEMBLY
 3. 620083 - SEAL KIT

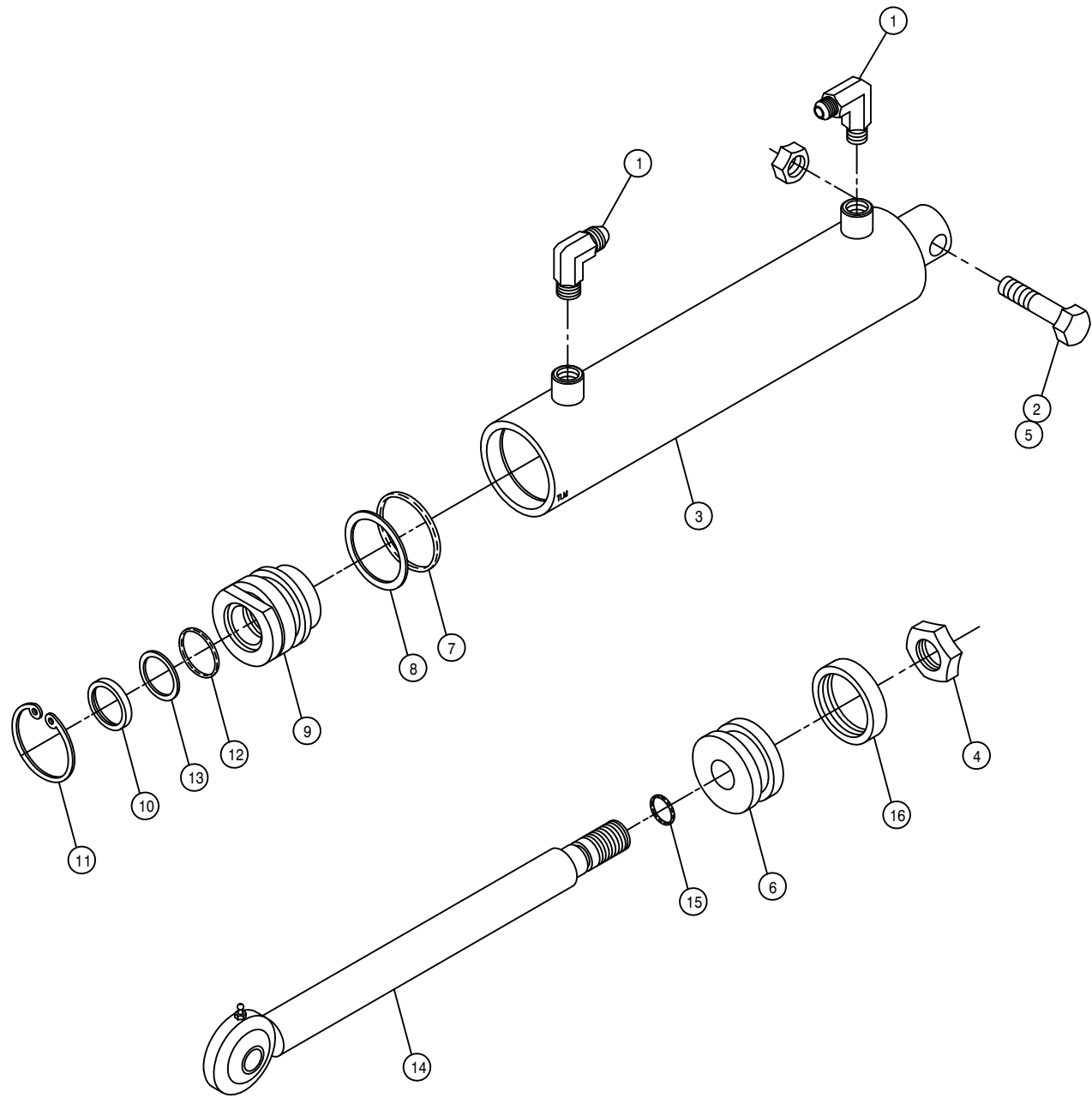

125" TIE ROD TREAD ADJ CYLINDER ASSEMBLY

DET. QTY PART NO. DESCRIPTION

1	2	614710	RESTRICTOR ELBOW ASSY .025DIA
2	1	900268	1/2UNC X 2 1/2 HEX BOLT
3	1	620124	CYL TUBE WLD,STRG, 125" TA 94
4	1	472297	3/4UNF HEX STOVER NUT THIN
5	1	914008	1/2UNC HEX STOVER NUT
6	1	620081	PISTON 2 X 1 ZAMAC ORING TYPE
7	1	870326	BUNA ORING 1 5/8 X 2
8	1	890326	BACKUP WASH 1 5/8 X 2 LEATH
9	1	620126	GLAND 2.00 OD X 1.25 ID, ALUM
10	1	629002	WIPER 1 1/4 X 1 1/2 X 1/8
11	1	629505	SNAP RING 2 IN INTRN
12	1	870218	BUNA ORING 1 1/4 X 1 1/2
13	1	890218	BACKUP WASH1 1/4X1 1/2 HT2022
14	1	620130	CYL SHAFT WLD,STRG,TREADADJ94
15	1	870113	BUNA ORING 9/16 X 3/4
16	1	860326	CROWN SEAL, 2" PISTON, HYD

NOTE: 1. 620123 - 125" TREAD ADJ STEERING CYLINDER ASSEMBLY
 2. 620132 - SEAL KIT

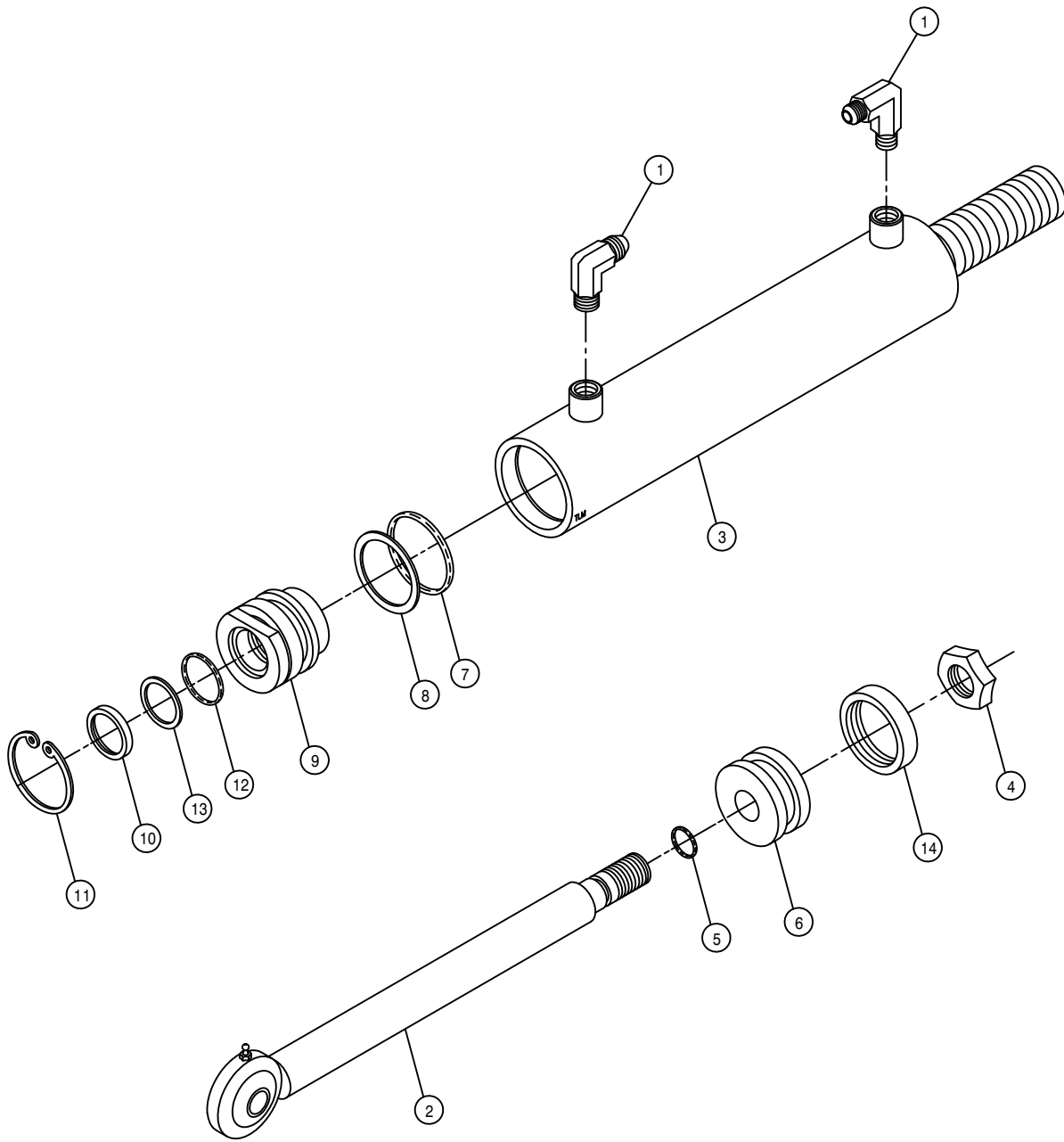

90" TIE ROD TREAD ADJ CYLINDER ASSEMBLY

DET.	QTY	PART NO.	DESCRIPTION
1	2	614710	RESTRICTOR ELBOW ASSY .025DIA
2	1	620130	CYL SHAFT WLD, STRG, TREADADJ94
3	1	620116	TREAD ADJ STRG CYL TUBE WLD
4	1	472297	3/4UNF HEX STOVER NUT THIN
5	1	870113	BUNA ORING 9/16 X 3/4
6	1	620081	PISTON 2 X 1 ZAMAC ORING TYPE
7	1	870326	BUNA ORING 1 5/8 X 2
8	1	890326	BACKUP WASH 1 5/8 X 2 LEATH
9	1	620126	GLAND 2.00 OD X 1.25 ID, ALUM
10	1	629002	WIPER 1 1/4 X 1 1/2 X 1/8
11	1	629505	SNAP RING 2 IN INTRN
12	1	870218	BUNA ORING 1 1/4 X 1 1/2
13	1	890218	BACKUP WASH 1 1/4 X 1 1/2 HT2022
14	1	860326	CROWN SEAL, 2" PISTON, HYD

NOTE: 1. 620122 - 90" TREAD ADJ STEERING CYLINDER ASSEMBLY
 2. 620132 - SEAL KIT

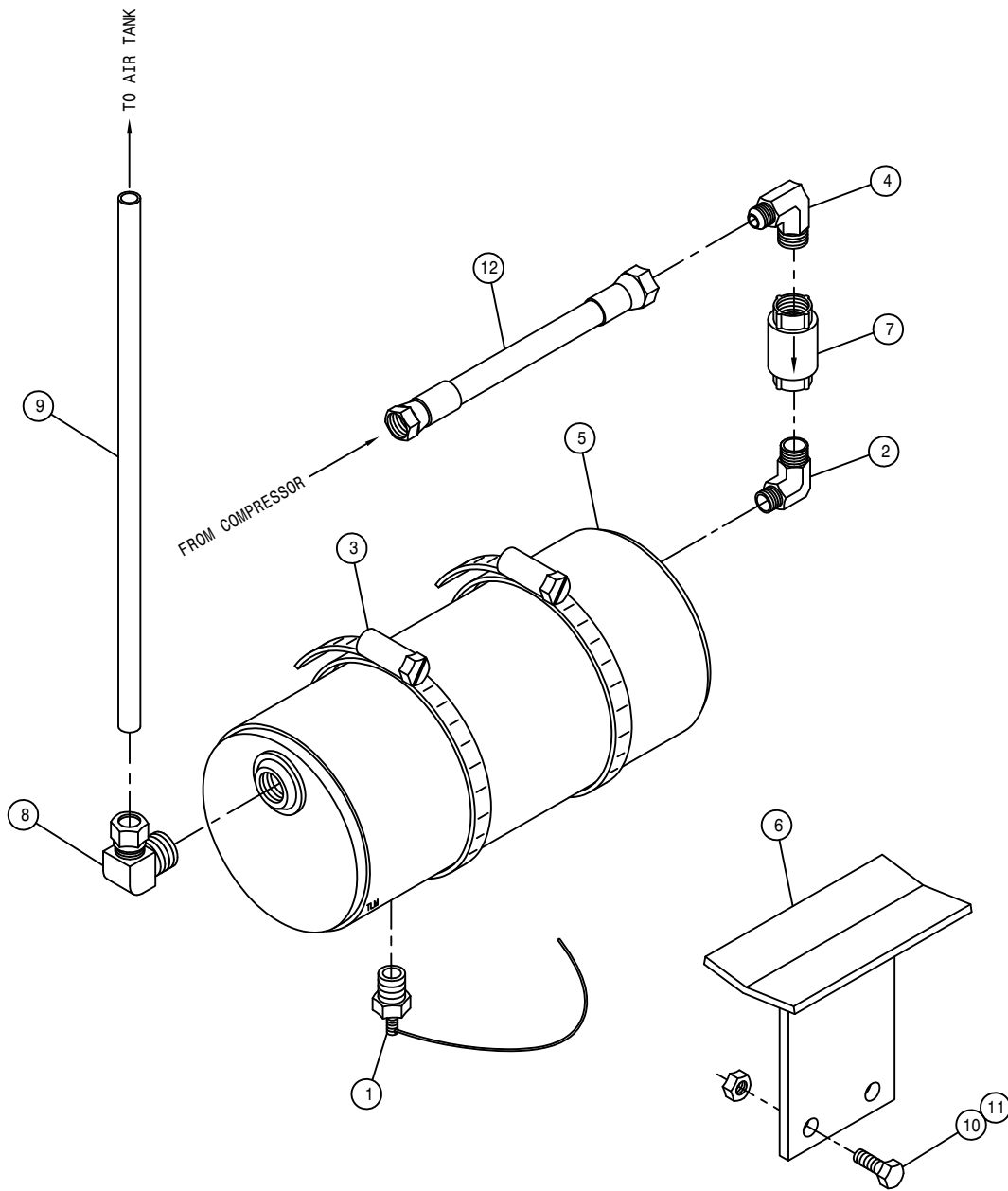

AIR WET TANK ASSEMBLY

DET.	QTY	PART NO.	DESCRIPTION	
1	1	470266	DRAIN VALVE KIT, 1/4NPT	
2	1	618711	3/4MNPT-90-1/2MNPT REDU LBO	
3	2	520086	HOSE CLAMP NO 88 STAINLESS	
4	1	610305	3/4MJIC-90-3/4MNPT LBO	
5	1	701115	WET TANK WLD	98
6	1	701146	WET TANK MTG BRKT WLD, 284	99
7	1	711050	3/4"FNPT CHECK VALVE S.S.	
8	1	711035	1/2MNPT-90-1/2NYL TUBE FTG BRS	
9	1	601441	HOSE, 1/2 X 20 AIR	
10	2	900129	3/8UNC X 1" HEX BOLT	
11	2	914004	3/8UNC HEX STOVER NUT	
12	1	611301	08P919-08FJX-08FJX-18	H/A

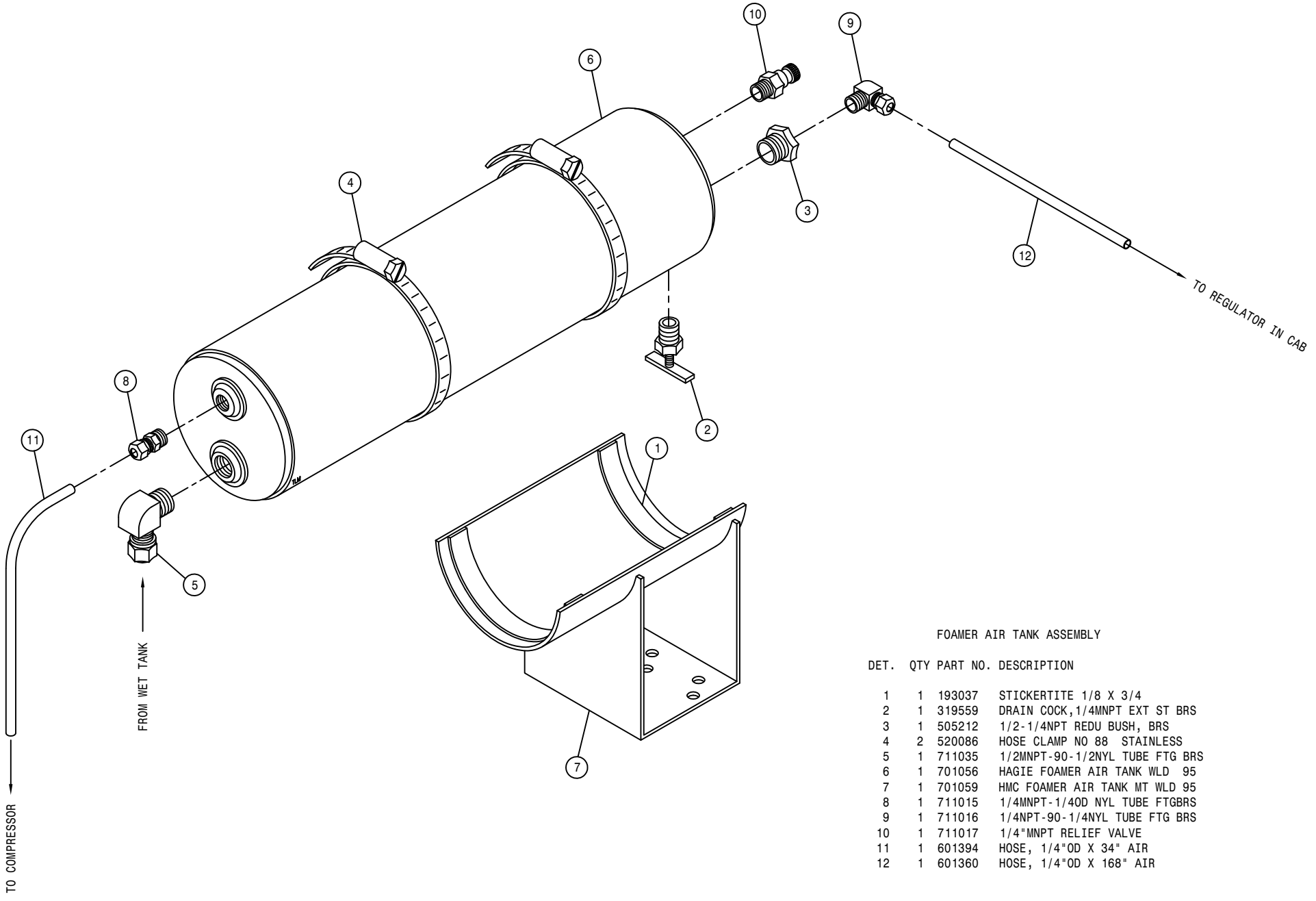

FOAMER AIR TANK ASSEMBLY

DET.	QTY	PART NO.	DESCRIPTION
	1	193037	STICKERTITE 1/8 X 3/4
	1	319559	DRAIN COCK, 1/4MNPT EXT ST BRS
	1	505212	1/2-1/4NPT REDU BUSH, BRS
	2	520086	HOSE CLAMP NO 88 STAINLESS
	1	711035	1/2MNPT-90-1/2NYL TUBE FTG BRS
	1	701056	HAGIE FOAMER AIR TANK WLD 95
	1	701059	HMC FOAMER AIR TANK MT WLD 95
	1	711015	1/4MNPT-1/4OD NYL TUBE FTGBRS
	1	711016	1/4NPT-90-1/4NYL TUBE FTG BRS
	1	711017	1/4"MNPT RELIEF VALVE
	1	601394	HOSE, 1/4"OD X 34" AIR
	1	601360	HOSE, 1/4"OD X 168" AIR

FOAM MARKER TANK ASSEMBLY

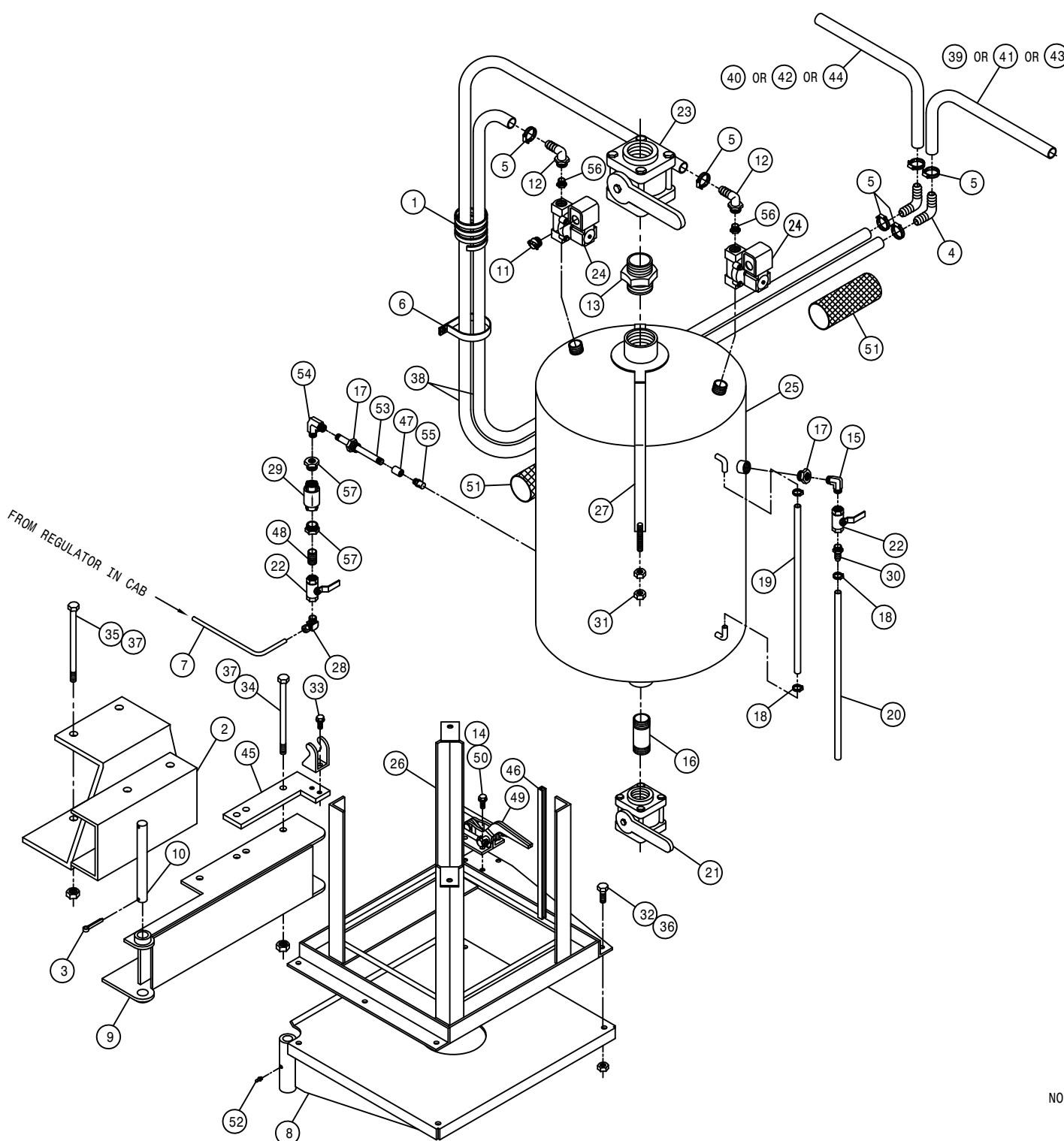

DET.	QTY	PART NO.	DESCRIPTION
1	2	193002	SPIRAL PROTECTIVE WRAP, BLACK
2	1	341980	RH REAR TOOL BAR MT WLD 2XX
3	2	470039	COTTER PIN 3/16 X 1 1/4 SQCUT
4	2	500069	3/4-90-3/4 HOSE BARB, POLY
5	6	520055	HOSE CLAMP NO 12 STAINLESS
6	1	520126	CUSH HOSE CLAMP 2IN X 5/8W
7	1	601366	HOSE, 1/4 X 192 AIR
8	1	701043	HAGIE FOAMER BASE WLD 95
9	1	701048	HAGIE FOAMER BASE MT WLD 95
10	1	701055	HMC FOAMER BASE PIVOT PIN 95
11	3	293056	ROMEX CONNECTOR .50IN 2-SCR
12	2	701150	3/4NPT-90-3/4HBARB, TAPPED, POLY
13	1	500056	2" NPT CLOSE HEX NIPPLE, POLY
14	4	470233	5/16UNC X 3/4 FLANGE HEX BOLT
15	1	502705	1/4NPT-90-1/4NPT LBO, BRS
16	1	505202	BLK PIPE NIPPLE 1.00NPT-2.00
17	2	505211	3/8-1/4NPT REDU BUSH, BRS
18	3	520120	HOSE CLAMP NO 4 STAINLESS
19	1	601364	HOSE, 3/8 X 16 CLEAR VINYL
20	1	601370	HOSE, 3/8 X 30 CLEAR VINYL
21	1	695900	BALL VALVE 1IN FNPT POLY
22	2	696120	BALL VALVE, 1/4NPT, STEEL
23	1	696134	BALL VALVE 2IN FNPT POLY
24	2	696163	3/4" ELECT SOLENOID VALVE
25	1	701091	FOAM MARKER TANK, 20 GAL SS
26	1	701093	FOAM MARKER TANK MT WLD
27	1	701099	FOAM MARKER TANK STRAP WLD
28	1	711016	1/4NPT-90-1/4NYL TUBE FTG BRS
29	1	711050	3/4"FNPT CHECK VALVE S.S.
30	1	783304	1/4 NPT X 3/8 HOSE BARB, BRS
31	4	910004	3/8UNC HEX NUT
32	4	900129	3/8UNC X 1" HEX BOLT
33	2	470232	5/16UNC X 1/2 FLANGE HEX BOLT
34	2	900278	1/2UNC X 6" HEX BOLT
35	2	900281	1/2UNC X 7 1/2 HEX BOLT
36	4	914004	3/8UNC HEX STOVER NUT
37	4	914008	1/2UNC HEX STOVER NUT
38	2	195908	HOSE, 3/4ID-1/8W CLEAR VINYL X 168.00
39	1	195908	HOSE, 3/4ID-1/8W CLEAR VINYL X 588.00
40	1	195908	HOSE, 3/4ID-1/8W CLEAR VINYL X 612.00
41	1	195908	HOSE, 3/4ID-1/8W CLEAR VINYL X 708.00
42	1	195908	HOSE, 3/4ID-1/8W CLEAR VINYL X 732.00
43	1	195908	HOSE, 3/4ID-1/8W CLEAR VINYL X 768.00
44	1	195908	HOSE, 3/4ID-1/8W CLEAR VINYL X 792.00
45	1	701105	FOAM MARKER TANK LATCH MT
46	8	193016	QUICKEDGE TRIM .060 TO .170
47	1	500202	SS PIPE CPLG, 1/8NPT .563 OD
48	1	502707	PIPE NIP, 1/4NPT HEX CLOSE, BRS
49	1	470238	DE-STA-CO CLAMP, TC-341 LATCH
50	4	470113	5/16UNC HEX FLANGE LOCK NUT
51	2	342333	NYL HOSE SLEEVE, 2.64ID X 12.00
52	1	471005	1/4 28 X 1/2 GREASE ZERK
53	1	507021	SS PIPE NIPPLE, 1/8NPT X 6"
54	1	701143	FOAMER AIR TUBE FTG
55	1	701144	FOAMER AIR NOZZLE
56	2	701151	3/8PIPE PLUG, .187 ORIFICE, POLY
57	2	507724	REDU BUSH 3/4MNPT X 1/4FNPT, SS

NOTE: 1. DETAIL 39 AND 40 ARE USED WITH THE 60 FT BOOM.
 2. DETAIL 41 AND 42 ARE USED WITH THE 80 FT BOOM.
 3. DETAIL 43 AND 44 ARE USED WITH THE 90 FT BOOM.

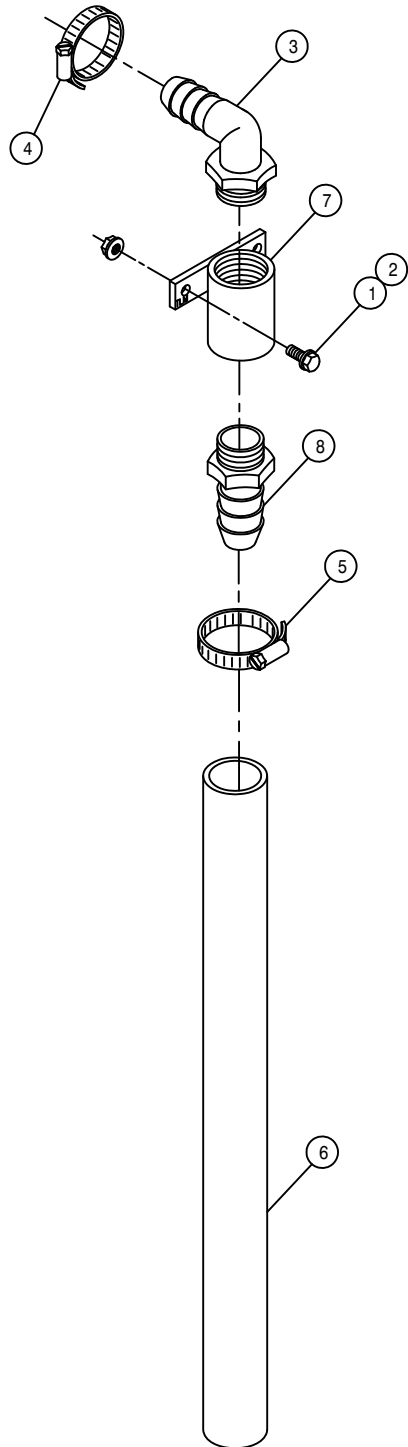

FOAMER DROP END ASSEMBLY

DET. QTY PART NO. DESCRIPTION

1	4	470118	1/4UNC X 3/4 FLANGE HEX BOLT
2	4	470121	1/4UNC HEX FLANGE LOCK NUT
3	2	500067	1 NPT-90-3/4 HOSE BARB, POLY
4	2	520055	HOSE CLAMP NO 12 STAINLESS
5	2	520085	HOSE CLAMP NO 24 STAINLESS
6	2	601367	HOSE, 1.25 2BR EPDM X 24.00
7	2	701102	FOAM MARKER DROP CPLR WELD
8	2	714561	1.00NPT-1.25 HOSE BARB

NOTE: QUANTITY LISTED IS FOR ONE MACHINE.

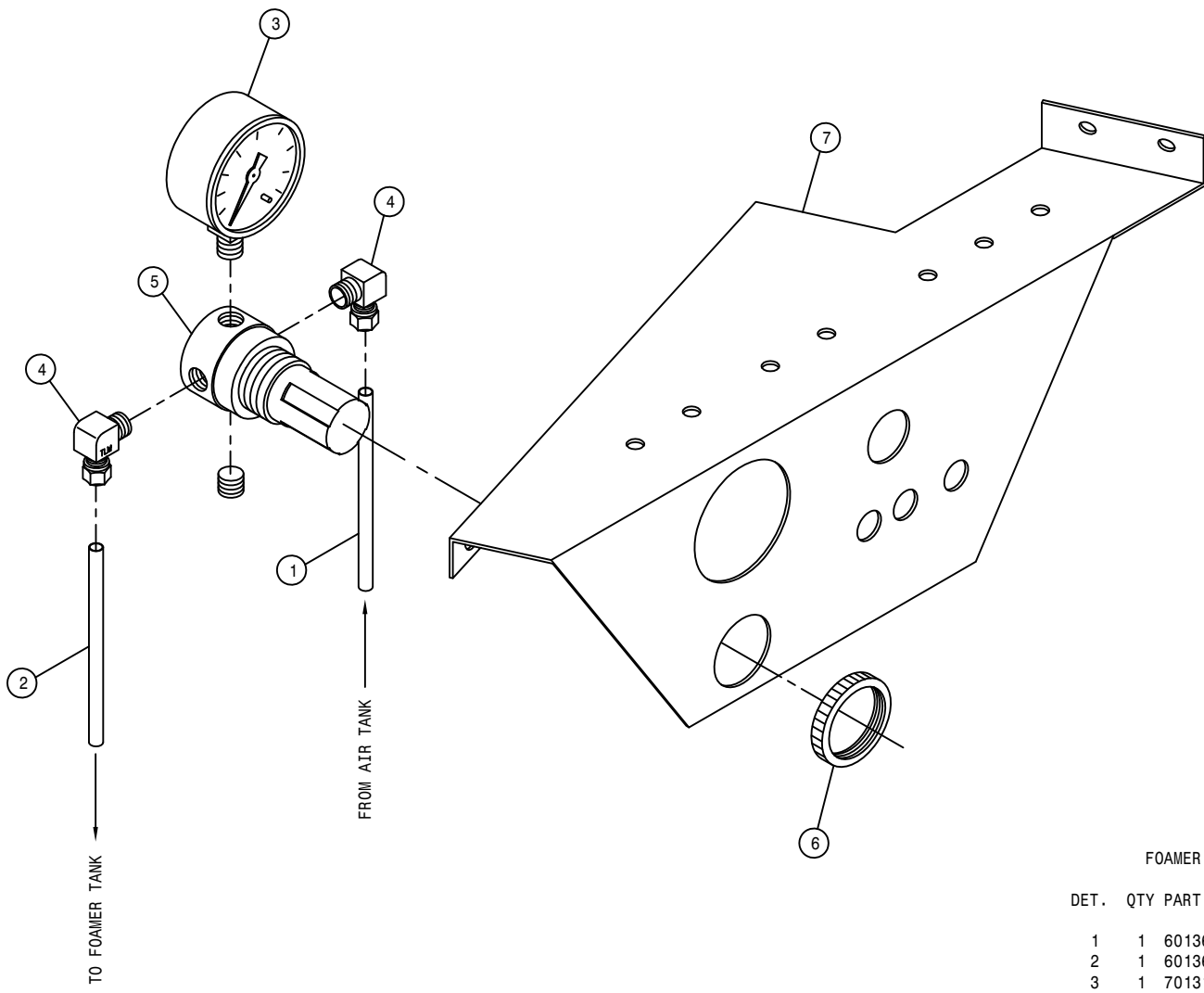

FOAMER AIR REGULATOR ASSEMBLY

DET. QTY PART NO. DESCRIPTION

1	1	601360	HOSE, 1/4"OD X 168" AIR	
2	1	601366	HOSE, 1/4"OD X 192" AIR	
3	1	701310	AIR PRESS GAUGE, 1/8"BOT	
4	2	711016	1/4NPT-90-1/4NYL TUBE FTG BRS	
5	1	711019	1/4"MNPT AIR REGULATOR	
6	1	711021	1 1/4-18 NUT,AIR REGULATOR MT	
7	1	342215	MONITOR MT, 284 CAB	94

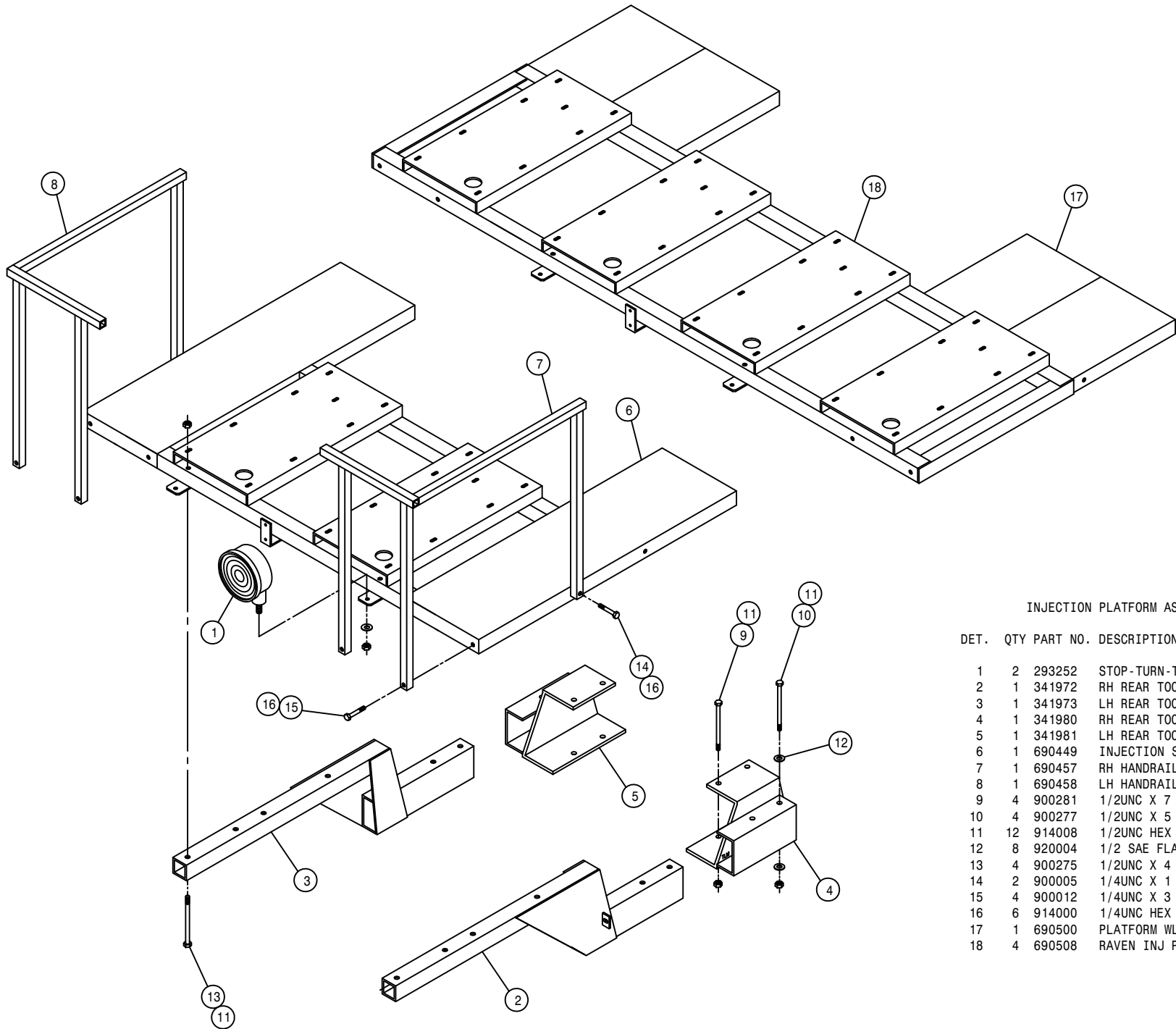

INJECTION PLATFORM ASSEMBLY

DET. QTY PART NO. DESCRIPTION

1	2	293252	STOP-TURN-TAIL LAMP PED MT
2	1	341972	RH REAR TOOL BAR WLD 2XX 92
3	1	341973	LH REAR TOOL BAR WLD 2XX 92
4	1	341980	RH REAR TOOL BAR MT WLD 2XX
5	1	341981	LH REAR TOOL BAR MT WLD 2XX
6	1	690449	INJECTION SYS MT/PLATFORM WLD
7	1	690457	RH HANDRAIL WLD, INJ PLATFORM
8	1	690458	LH HANDRAIL WLD, INJ PLATFORM
9	4	900281	1/2UNC X 7 1/2 HEX BOLT
10	4	900277	1/2UNC X 5 1/2 HEX BOLT
11	12	914008	1/2UNC HEX STOVER NUT
12	8	920004	1/2 SAE FLAT WASHER
13	4	900275	1/2UNC X 4 1/2 HEX BOLT
14	2	900005	1/4UNC X 1 1/2 HEX BOLT
15	4	900012	1/4UNC X 3 1/2 HEX BOLT
16	6	914000	1/4UNC HEX STOVER NUT
17	1	690500	PLATFORM WLD, 3 & 4 UNIT SYS
18	4	690508	RAVEN INJ PUMP/TANK MT CHAN

HYPRO D230 PUMP ASSEMBLY

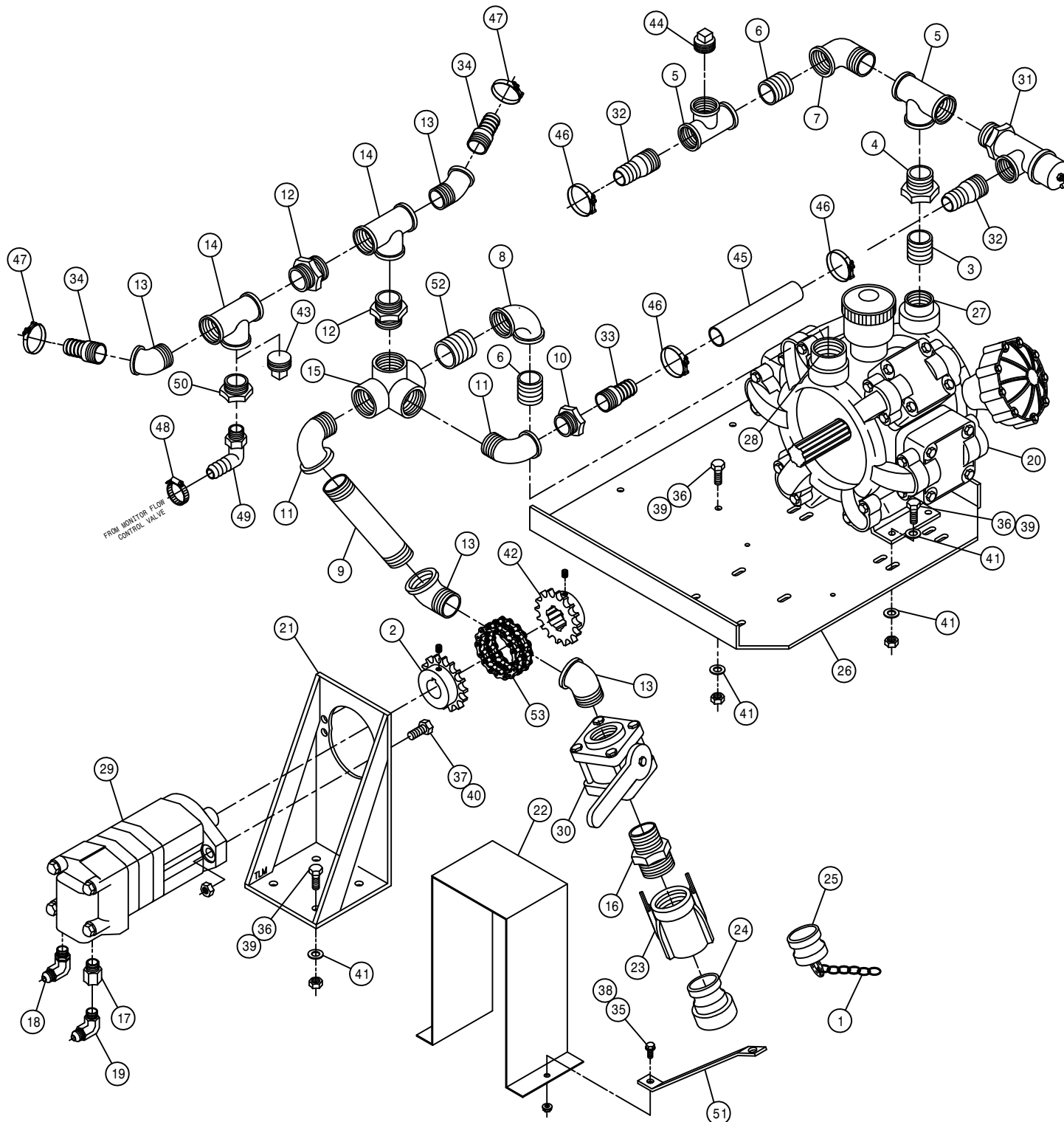

DET.	QTY	PART NO.	DESCRIPTION
1	1	160986	CHAIN, 12.00 LONG
2	1	220026	SPROCKET,40BS16,1.25ID,.312KE
3	1	505201	CLOSE NIPPLE 1.00NPT
4	1	506005	1 1/4 TO 1 RED BUSH BLK MAL
5	2	506105	BLK PIPE TEE 1.25NPT
6	2	506200	CLOSE NIPPLE 1.25NPT
7	1	506410	BLK PIPE ST EL 90DEG 1.25NPT
8	1	506415	RED EL 90 1 1/2 TO 1 1/4 MAL
9	1	500029	1 1/2NPT X 6 PIPE NIPPLE,POLY
10	1	500037	1 1/2"X 1 1/4NPT BUSH, POLY
11	2	500034	1 1/2NPT-90 ST EL, POLY
12	2	500028	1 1/2NPT PIPE NIPPLE, POLY
13	4	500035	1 1/2"X 1 1/4NPT BUSH, POLY
14	2	500030	1 1/2"NPT PIPE TEE, POLY
15	1	507253	BLK PIPE SIDE OUTLET TEE 1.50
16	1	500038	2"X 1 1/2NPT REDU NIPPLE,POLY
17	1	618171	7/8MOR-3/4FOR ADPTR
18	1	618183	3/4MJIC-90-7/8MOR LBO
19	1	618241	3/4MJIC-90-3/4MOR LBO
20	1	690339	HYPRO D230 DIAPHRAM PUMP
21	1	690353	D150-D230 PUMP MTR MT WLD
22	1	690364	D150-D230 PUMP CPLR SHLD
23	1	690390	2.00 FEMALE NPT COUPLER
24	1	690391	2.00 FEMALE NPT ADPTR
25	1	690392	ADPTR PLG FOR 2.00 NPT COUPLR
26	1	690414	230 HYPRO PUMP MT PLT 280 90
27	1	690417	1FNPT ADAPTER, HYPRO D230
28	1	690418	1 1/4FNPT ADAPTER, HYPRO D230
29	1	695985	CHAR LYNN 2000 SER HYD MTR 79
30	1	696110	BALL VALVE 1 1/2FNPT POLY
31	1	699702	HAMILTON RELIEF VLV 200PSI
32	2	715660	HOSE BARB 1 1/4NPT X 1 1/4
33	1	500033	1 1/4NPT X 1 1/4 H BARB, POLY
34	2	500032	1 1/2NPT X 1 1/2 H BARB, POLY
35	2	900003	1/4UNC X 1" HEX BOLT
36	12	900129	3/8UNC X 1" HEX BOLT
37	2	900265	1/2UNC X 1 1/2 HEX BOLT
38	2	914000	1/4UNC HEX STOVER NUT
39	12	914004	3/8UNC HEX STOVER NUT
40	2	914008	1/2UNC HEX STOVER NUT
41	16	920002	3/8 SAE FLAT WASHER
42	1	220027	SPROCKET WLD,4016-1.375-6SPL
43	1	500031	1 1/2NPT PIPE PLUG, POLY
44	1	506101	PIPE PLUG 1.25NPT SQ HD
45	1	197120	HOSE 1 1/4 2-FBR BR BLK EPDM
46	3	520132	1.62/1.87 T-BOLT HOSE CLAMP
47	2	520133	1.81/2.06 T-BOLT HOSE CLAMP
48	1	520087	HOSE CLAMP NO 20 PLATED
49	1	500024	1"NPT-90-1"HOSE BARB, POLY
50	1	500036	1 1/2"X 1"NPT REDU BUSH, POLY
51	1	690480	VLV/CPLR SUPPORT,D230 PUMP 94
52	1	507019	CLOSE NIPPLE 1.50NPT
53	1	492084	CHAIN FOR 492083 4016

*NOTE: ITEMS 48,49, AND 50 ARE USED WITH THE MONITOR OPTION.

HYPRO D230 HP MANIFOLD ASSEMBLY

DET. QTY PART NO. DESCRIPTION

DET.	QTY	PART NO.	DESCRIPTION
1	1	503400	BLK PIPE ST EL 90DEG .50NPT
2	1	504210	RED BUSH 3/4 NPT X 1/2 NPT
3	3	505200	BLK PIPE ST EL 90DEG 1.00NPT
4	2	618281	1/2MNPT X 1/2 HOSE INSERT
5	3	696162	1" ELECT BALL VLV, 344AEC-2-1
6	1	695984	SOLU MANIF WLD D150-D230
7	2	695994	SOLU MANIF KEEPER OPTION
8	3	714560	1NPT X 1 HOSE BARB
9	1	715660	HOSE BARB 1 1/4NPT X 1 1/4
10	1	507015	RED BUSH 1.50NPT - 1.25FNPT
11	1	504900	PIPE PLUG .75NPT SQ HD
12	4	900072	5/16UNC X 3" HEX BOLT
13	4	914002	5/16UNC HEX STOVER NUT
14	1	341520	PRESSURE GAUGE MT WLD 8240X11
15	1	501450	BLK PIPE ST EL 90DEG .25NPT
16	1	503000	RED BUSH 1/2 TO 1/4 BLK MAL
17	1	701350	PRESS GAUGE 300LB BOT FILL
18	4	520080	HOSE CLAMP NO 10 STAINLESS
19	6	520087	HOSE CLAMP NO 20 STAINLESS
20	1	520132	1.62/1.87 T-BOLT HOSE CLAMP
21	1	197119	HOSE 1/2 2-FBR BR BLK EPDM X 206"
22	2	472349	1/4 X 3/4 20THD-IN TEK TYPE
23	2	197117	HOSE 1IN 2-FBR BR BLK EPDM X 288"
24	1	197117	HOSE 1IN 2-FBR BR BLK EPDM X 36"
25	1	506409	BLK PIPE ST EL 45DEG 1.25NPT

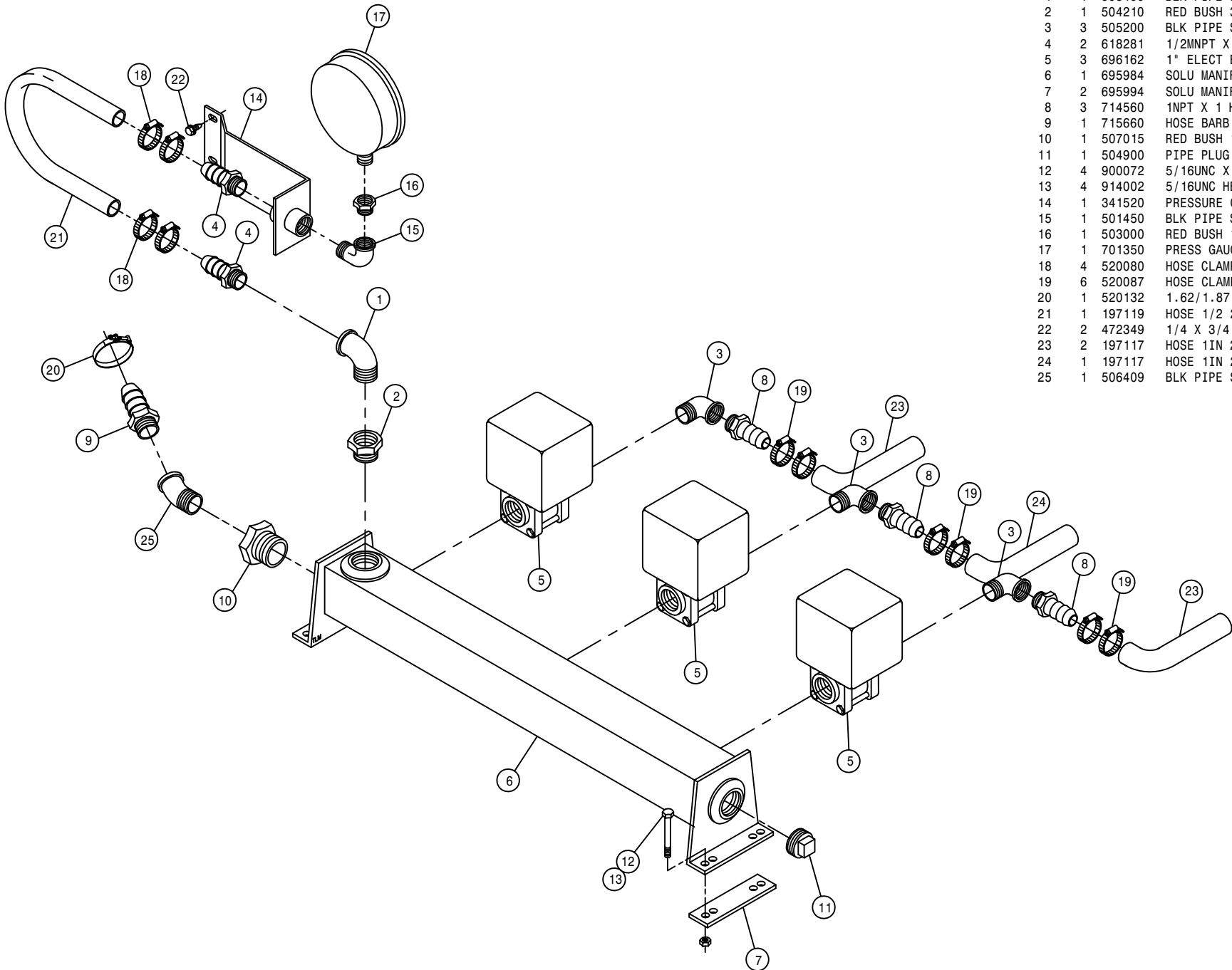

MONITOR FITTING ASSEMBLY FOR D230 PUMP

DET. QTY PART NO. DESCRIPTION

1	1	197117	HOSE 1IN 2-FBR BR BLK EPDM X 68.00
2	4	472349	1/4 X 3/4 20THD-IN TEK TYPE
3	1	505200	BLK PIPE ST EL 90DEG 1.00NPT
4	2	505201	CLOSE NIPPLE 1.00NPT
5	1	506005	1 1/4 TO 1 RED BUSH BLK MAL
6	1	506105	BLK PIPE TEE 1.25NPT
7	4	520132	1.62/1.87 T-BOLT HOSE CLAMP
8	2	520068	HOSE CLAMP NO 32 STAINLESS
9	1	690406	CONTROL VALVE, 1" POLY, RAVEN
10	1	696109	1 CONTROMATIC VALVE
11	1	714560	1NPT X 1 HOSE BARB
12	2	715660	HOSE BARB 1 1/4NPT X 1 1/4
13	1	520087	HOSE CLAMP NO 20 STAINLESS
14	1	690405	RFM 55 FLOW METER RAVEN
15	1	690481	CTRL VLV FTG SUPPORT WLD 94
16	1	197120	HOSE 1 1/4 2-FBR BR BLK EPDM X 96.00
17	1	197120	HOSE 1 1/4 2-FBR BR BLK EPDM X 4.00
18	1	197120	HOSE 1 1/4 2-FBR BR BLK EPDM X 115.00

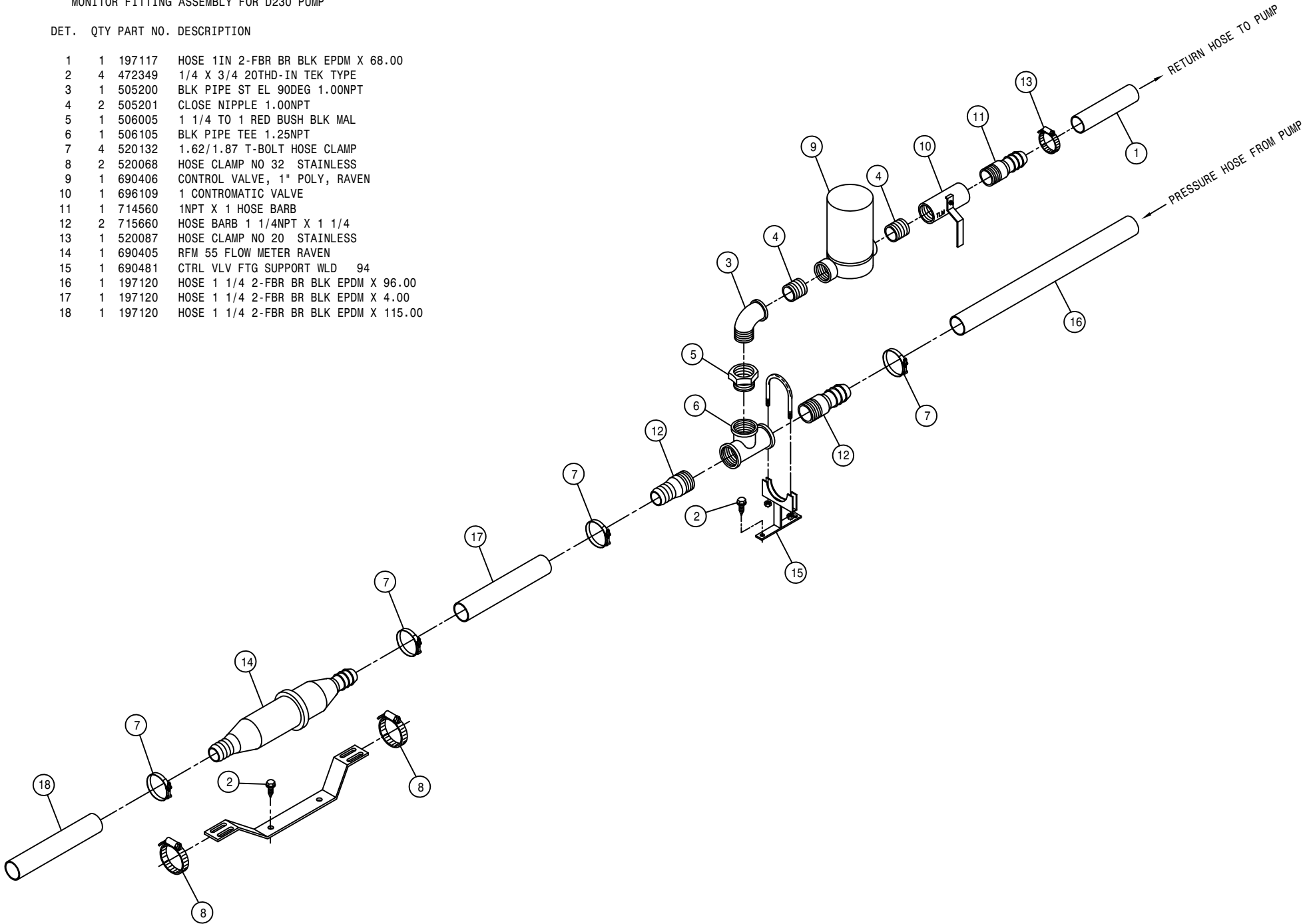

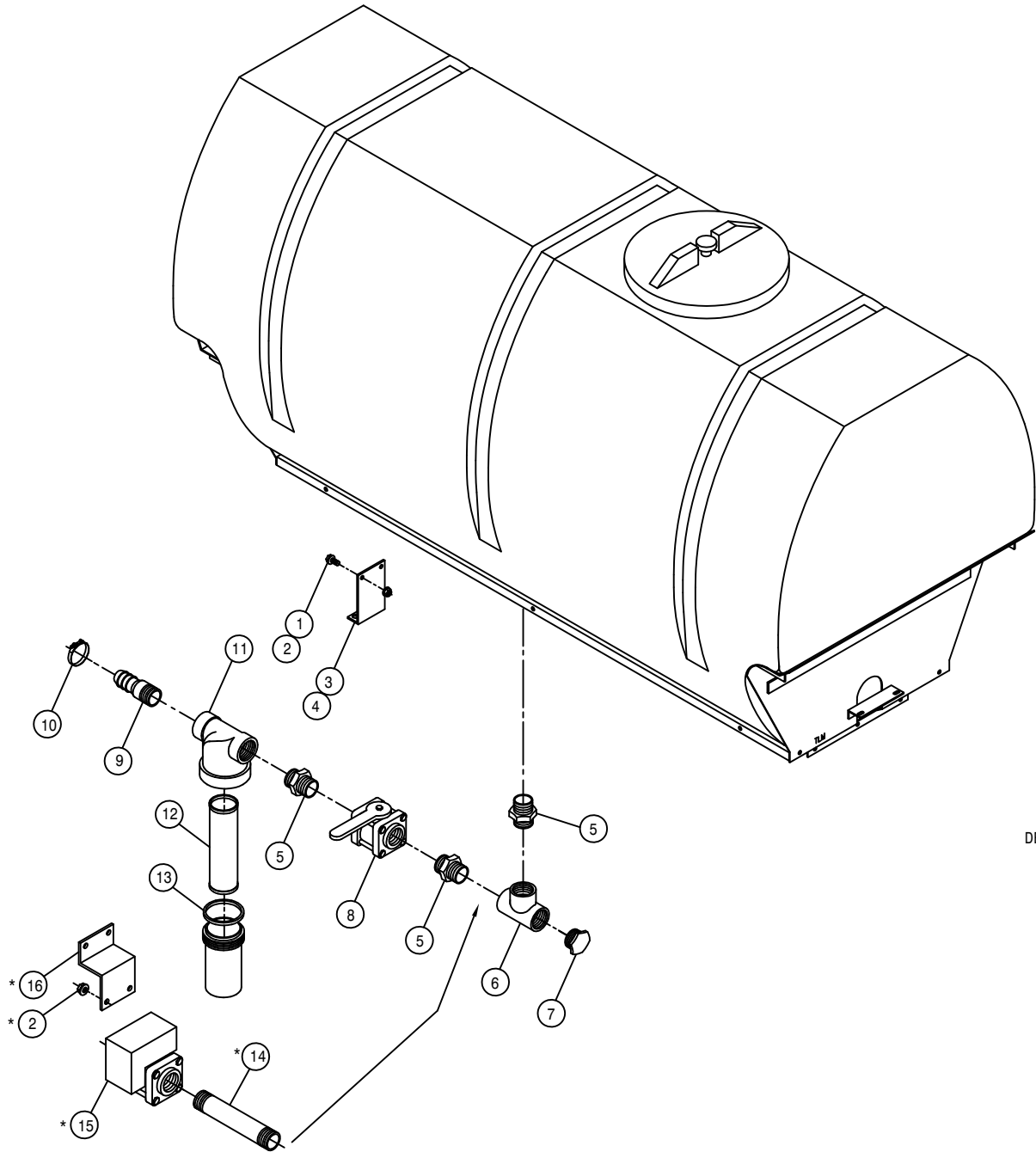

SOLUTION FILTER ASSEMBLY FOR D230 HP PUMP

DET.	QTY	PART NO.	DESCRIPTION
	1	2	470118 1/4UNC X 3/4 FLANGE HEX BOLT
	2	4	470121 1/4UNC HEX FLANGE LOCK NUT
	3	1	763363 SOLU HOSE SUPPORT 280 POLY 91
	4	1	470000 CABLE TIE, 21" BLACK PLASTIC
	5	3	500028 1 1/2NPT PIPE NIPPLE, POLY
	6	1	500030 1 1/2"NPT PIPE TEE, POLY
	7	1	500031 1 1/2NPT PIPE PLUG, POLY
	8	1	696110 BALL VALVE 1 1/2FNPT POLY
	9	1	500032 1 1/2NPT X 1 1/2 H BARB, POLY
	10	1	520133 1.81/2.06 T-BOLT HOSE CLAMP
	11	1	690474 1 1/2 LINE STRAINERSOM 150PSI
	12	1	690475 50 MESH SCREEN FOR 690474
	13	1	690476 STRAINER GASKEN FOR 690474
	14	1	500029 1 1/2NPT X 6 PIPE NIPPLE,POLY
	15	1	696161 1 1/2NPT ELECT SOLU VALVE
	16	1	763445 ELECT SOLU VLV SUPPORT 94

*NOTE: ITEMS 2, 14, 15, AND 16 ARE USED WITH ELECTRIC VALVE OPTION.

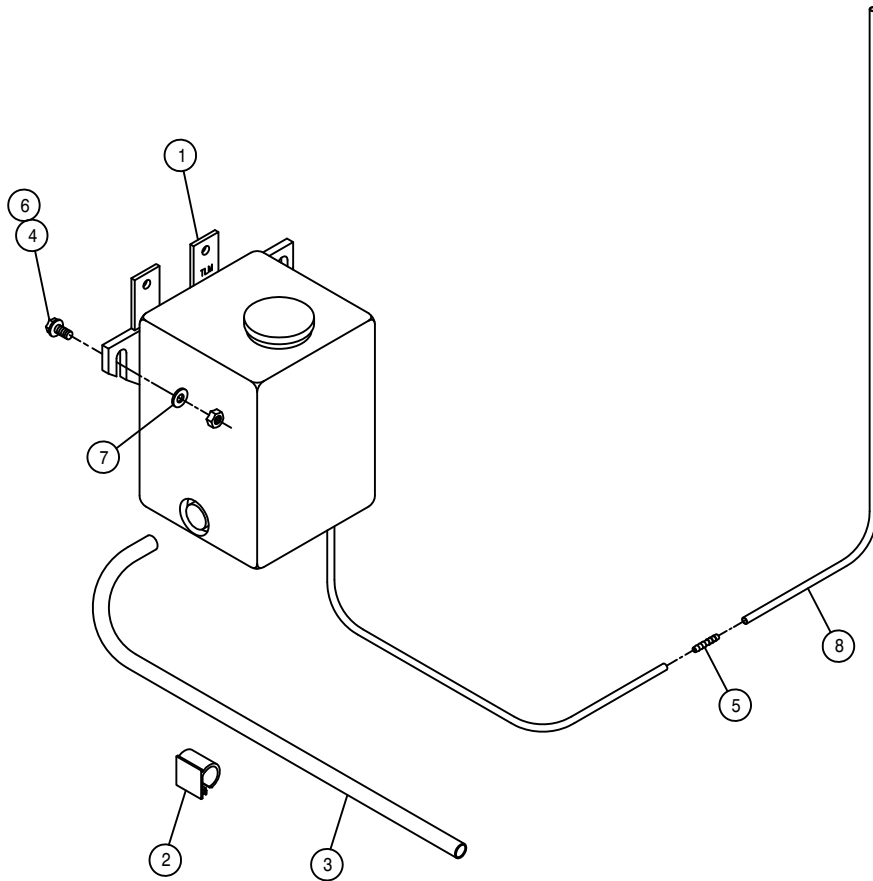

WINDSHIELD WASHER ASSEMBLY

DET. QTY PART NO. DESCRIPTION

1	1	290002	WINDSHIELD WASHER KIT
2	3	291645	3/8 WIRE CLAMP, ADHESIVE BACK
3	5	299110	WIRE FLEX GUARD .35 ID
4	3	470231	1/4UNC X 1" FLANGE HEX BOLT
5	1	711033	3/16-1/8 HOSE BARB REDU UNION
6	3	914000	1/4UNC HEX STOVER NUT
7	3	920000	1/4 SAE FLAT WASHER
8	14	195913	1/8 WINDSHIELD WASHER HOSE

CROP SHIELD ASSEMBLY

DET.	QTY	PART NO.	DESCRIPTION
1	2	662232	RH POLY CROP SHIELD, 284
2	2	662233	LH POLY CROP SHIELD, 284
3	2	662234	RH POLY CROP SHIELD MT WLD284
4	2	662235	LH POLY CROP SHIELD MT WLD284
5	4	662248	POLY SHIELD MT BRACE, 284
6	32	472261	1/4UNC X 3/4 TRUSS HD BOLT
7	32	483013	1 1/2 X 1/4 X 16 GA WASHER
8	32	470121	1/4UNC HEX FLANGE LOCK NUT
9	4	900128	3/8UNC X 3/4 HEX BOLT
10	8	470087	3/8UNC HEX FLANGE LOCK NUT
11	8	900264	1/2UNC X 1 1/4 HEX BOLT
12	8	914008	1/2UNC HEX STOVER NUT
13	4	900130	3/8UNC X 1 1/4 HEX BOLT

NOTE: QUANTITY LISTED IS FOR ONE MACHINE.

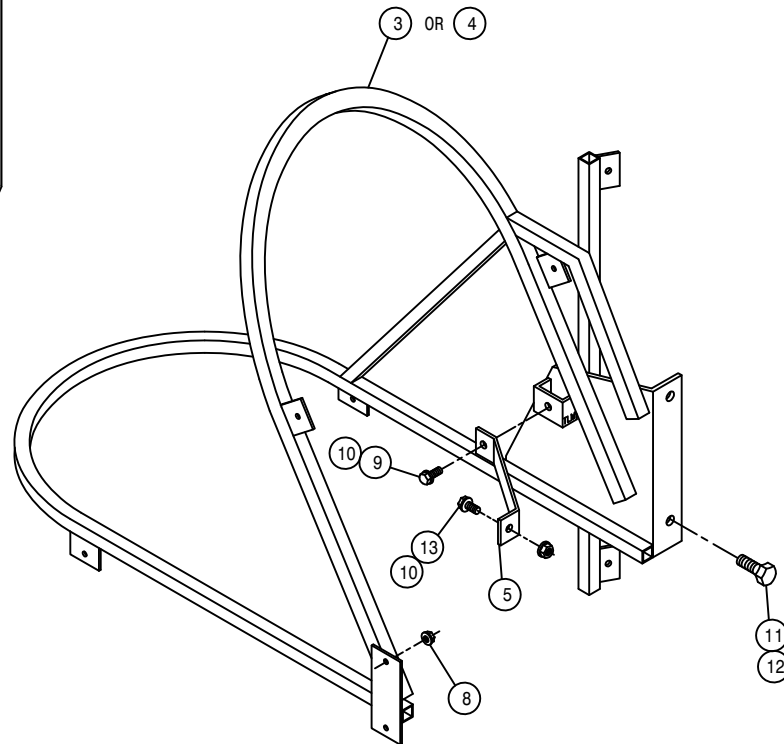
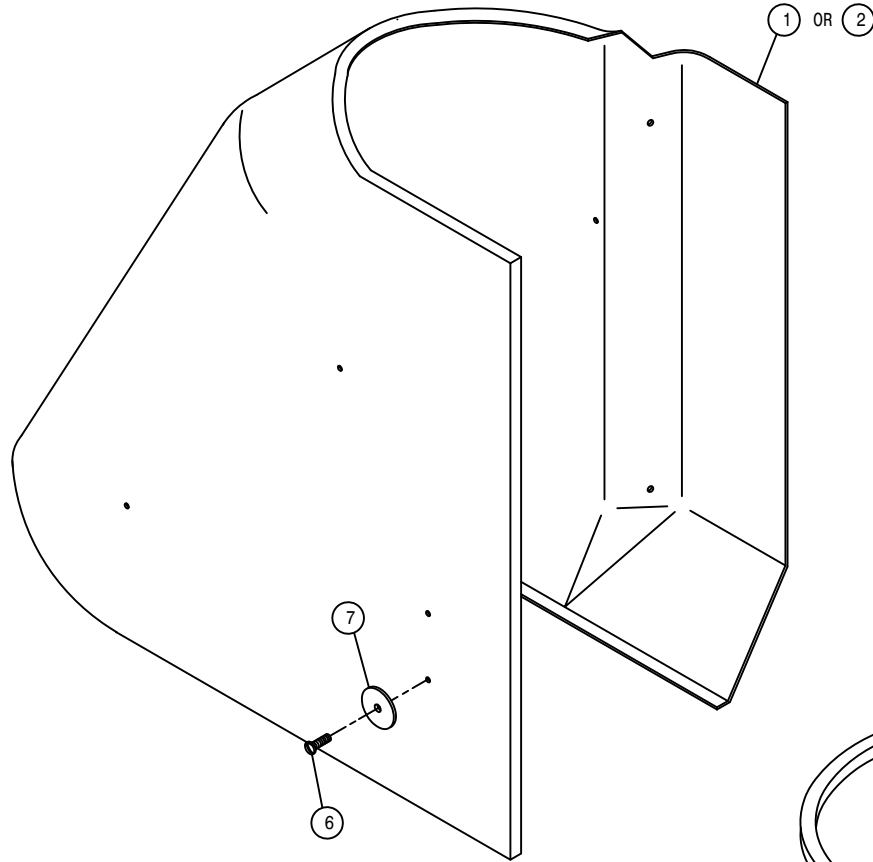

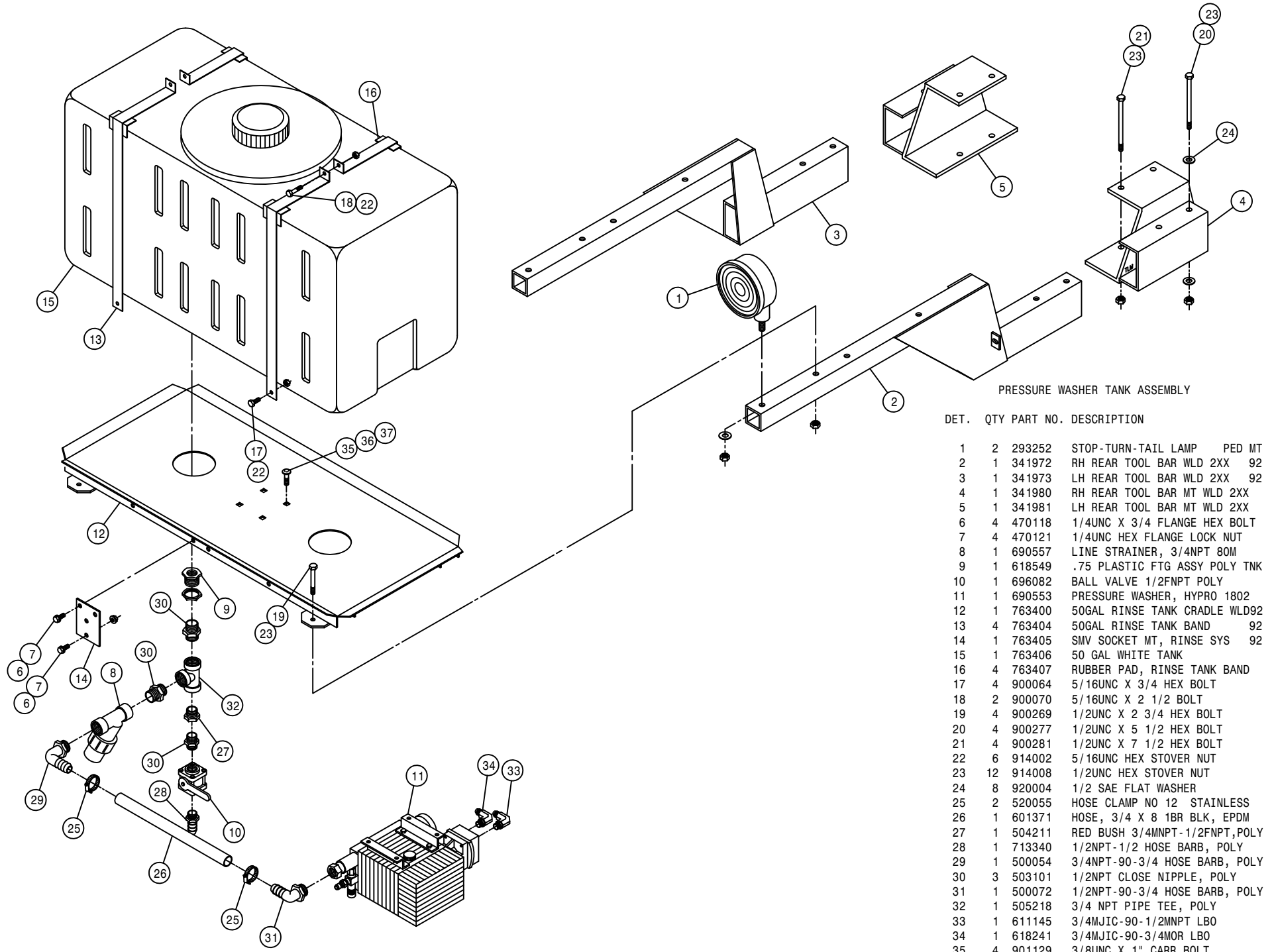

PRESSURE WASHER TANK ASSEMBLY

DET.	QTY	PART NO.	DESCRIPTION
1	2	293252	STOP-TURN-TAIL LAMP PED MT
2	1	341972	RH REAR TOOL BAR WLD 2XX 92
3	1	341973	LH REAR TOOL BAR WLD 2XX 92
4	1	341980	RH REAR TOOL BAR MT WLD 2XX
5	1	341981	LH REAR TOOL BAR MT WLD 2XX
6	4	470118	1/4UNC X 3/4 FLANGE HEX BOLT
7	4	470121	1/4UNC HEX FLANGE LOCK NUT
8	1	690557	LINE STRAINER, 3/4NPT 80M
9	1	618549	.75 PLASTIC FTG ASSY POLY TNK
10	1	696082	BALL VALVE 1/2FNPT POLY
11	1	690553	PRESSURE WASHER, HYPRO 1802
12	1	763400	50GAL RINSE TANK CRADLE WLD92
13	4	763404	50GAL RINSE TANK BAND 92
14	1	763405	SMV SOCKET MT, RINSE SYS 92
15	1	763406	50 GAL WHITE TANK
16	4	763407	RUBBER PAD, RINSE TANK BAND
17	4	900064	5/16UNC X 3/4 HEX BOLT
18	2	900070	5/16UNC X 2 1/2 BOLT
19	4	900269	1/2UNC X 2 3/4 HEX BOLT
20	4	900277	1/2UNC X 5 1/2 HEX BOLT
21	4	900281	1/2UNC X 7 1/2 HEX BOLT
22	6	914002	5/16UNC HEX STOVER NUT
23	12	914008	1/2UNC HEX STOVER NUT
24	8	920004	1/2 SAE FLAT WASHER
25	2	520055	HOSE CLAMP NO 12 STAINLESS
26	1	601371	HOSE, 3/4 X 8 1BR BLK, EPDM
27	1	504211	RED BUSH 3/4MNPT-1/2FNPT,POLY
28	1	713340	1/2NPT-1/2 HOSE BARB, POLY
29	1	500054	3/4NPT-90-3/4 HOSE BARB, POLY
30	3	503101	1/2NPT CLOSE NIPPLE, POLY
31	1	500072	1/2NPT-90-3/4 HOSE BARB, POLY
32	1	505218	3/4 NPT PIPE TEE, POLY
33	1	611145	3/4MJIC-90-1/2MNPT LBO
34	1	618241	3/4MJIC-90-3/4MOR LBO
35	4	901129	3/8UNC X 1" CARR BOLT
36	4	910004	3/8UNC HEX NUT
37	4	920502	3/8 LOCK WASHER

PRESSURE WASHER FLOW DIVIDER ASSEMBLY

DET. QTY PART NO. DESCRIPTION

DET.	QTY	PART NO.	DESCRIPTION	
1	1	606005	GRESEN SELECTOR VALVE S-10	
2	1	607518	FLO DIV BGR56 6GPM PRI 7/8FOR	
3	1	611126	7/8MJIC-7/8MOR ADPTR	
4	2	611128	7/8MJIC-90-7/8MOR LBO	
5	1	618183	3/4MJIC-90-7/8MOR LBO	
6	1	618333	7/8FJIC SW RUN TEE-7/8MJIC	
7	1	618451	3/4FJIC SW RUN TEE-3/4MJIC	
8	1	618523	7/8FJIC-3/4MJIC ADPTR	
9	1	618327	3/4MJIC-7/8MOR ADPTR	
10	1	618594	7/8FJIC SWIV-7/8MOR ADPTR	
11	1	618609	3/4MJIC-90-3/4FJIC SWIV LBO	
12	1	618628	7/8MJIC-45-7/8FJIC SWIV LBO	
13	1	502800	PIPE PLUG .375NPT SQ HD	
14	2	900007	1/4UNC X 2" HEX BOLT	
15	2	914000	1/4UNC HEX STOVER NUT	
16	1	763469	FLO DIV BRKT, PRESS WASHER	
17	2	615385	08C1T-08FJX-08FJX-29	H/A
18	1	615521	10C1T-10FJX-10FJX-18	H/A
19	1	615626	08C1T-08FJX-08FJX-15	H/A

97

TO PRESSURE WASHER

FROM PRESSURE WASHER

TO SOLUTION VFC

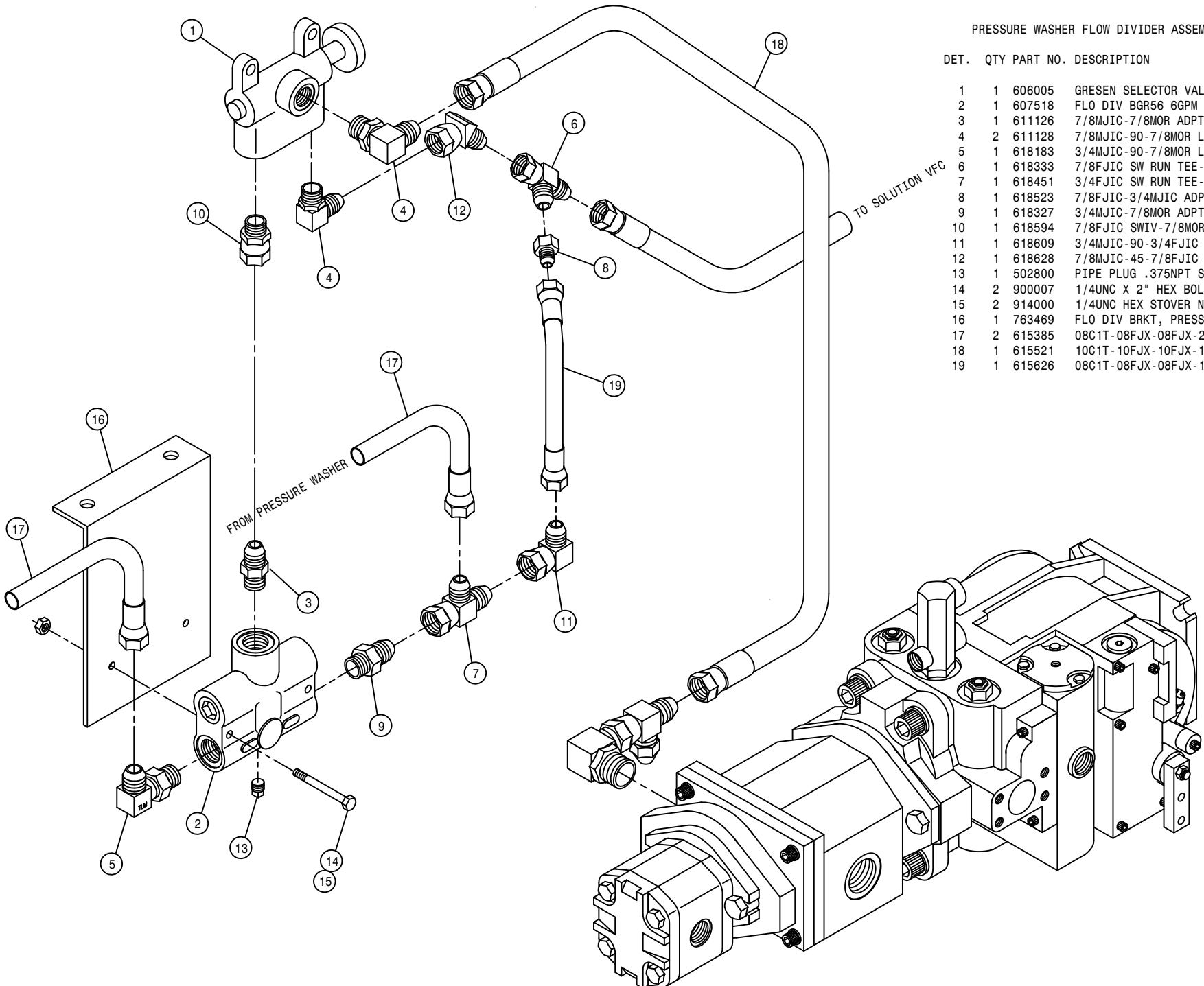

191097

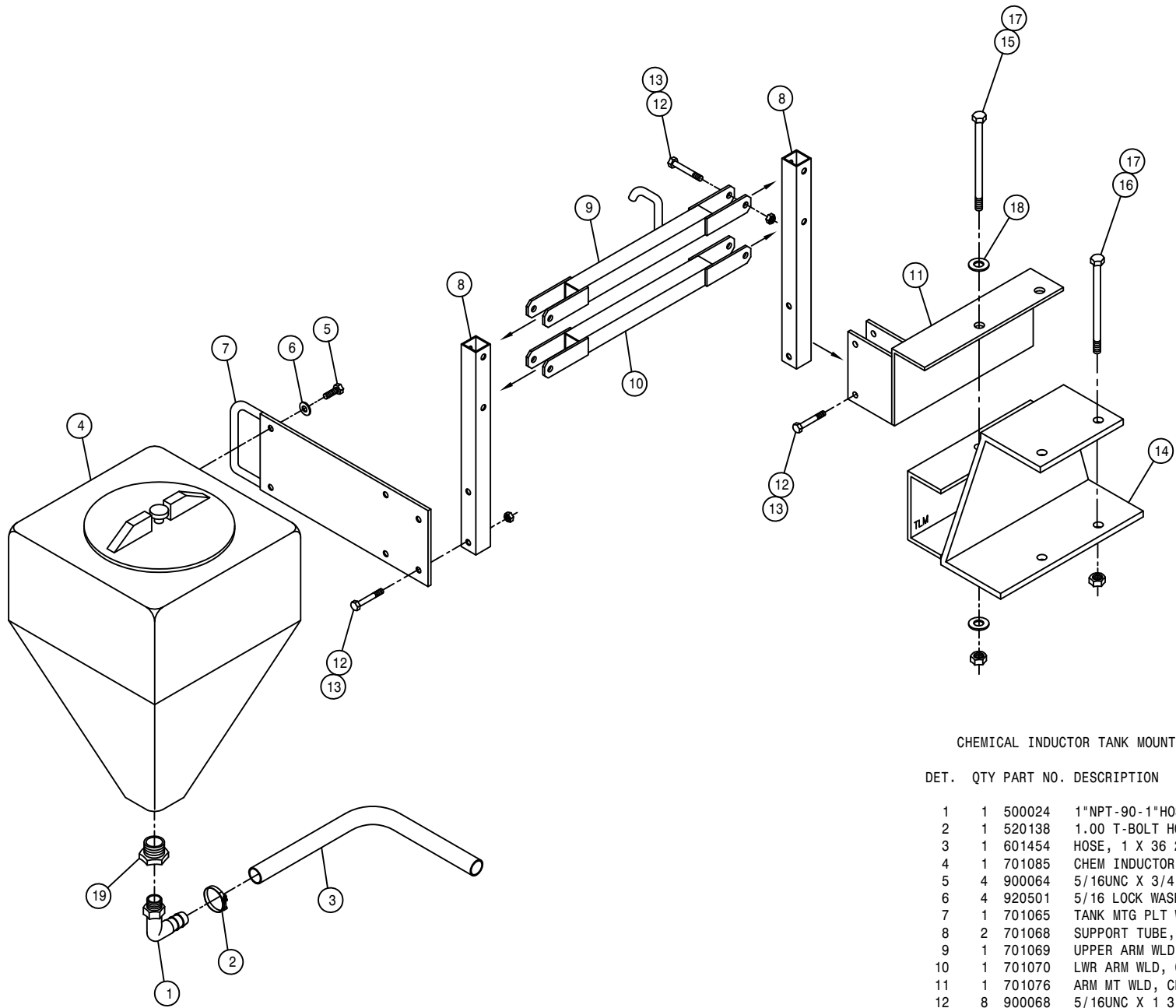

CHEMICAL INDUCTOR TANK MOUNT ASSEMBLY

DET. QTY PART NO. DESCRIPTION

DET.	QTY	PART NO.	DESCRIPTION
1	1	500024	1"NPT-90-1"HOSE BARB, POLY
2	1	520138	1.00 T-BOLT HOSE CLAMP
3	1	601454	HOSE, 1 X 36 2F-1W EPDM
4	1	701085	CHEM INDUCTOR TANK, 5 GAL, SQ
5	4	900064	5/16UNC X 3/4 HEX BOLT
6	4	920501	5/16 LOCK WASHER
7	1	701065	TANK MTG PLT WLD, CHEM INDUCTR
8	2	701068	SUPPORT TUBE, CHEM INDUCTOR
9	1	701069	UPPER ARM WLD, CHEM INDUCTOR
10	1	701070	LWR ARM WLD, CHEM INDUCTOR
11	1	701076	ARM MT WLD, CHEM INDUCTOR
12	8	900068	5/16UNC X 1 3/4 HEX BOLT
13	8	914002	5/16UNC HEX STOVER NUT
14	1	341981	LH REAR TOOL BAR MT WLD 2XX
15	2	900277	1/2UNC X 5 1/2 HEX BOLT
16	2	900281	1/2UNC X 7 1/2 HEX BOLT
17	4	914008	1/2UNC HEX STOVER NUT
18	4	920004	1/2 SAE FLAT WASHER
19	1	500099	1 1/4"X 1" NPT REDU BUSH, POL

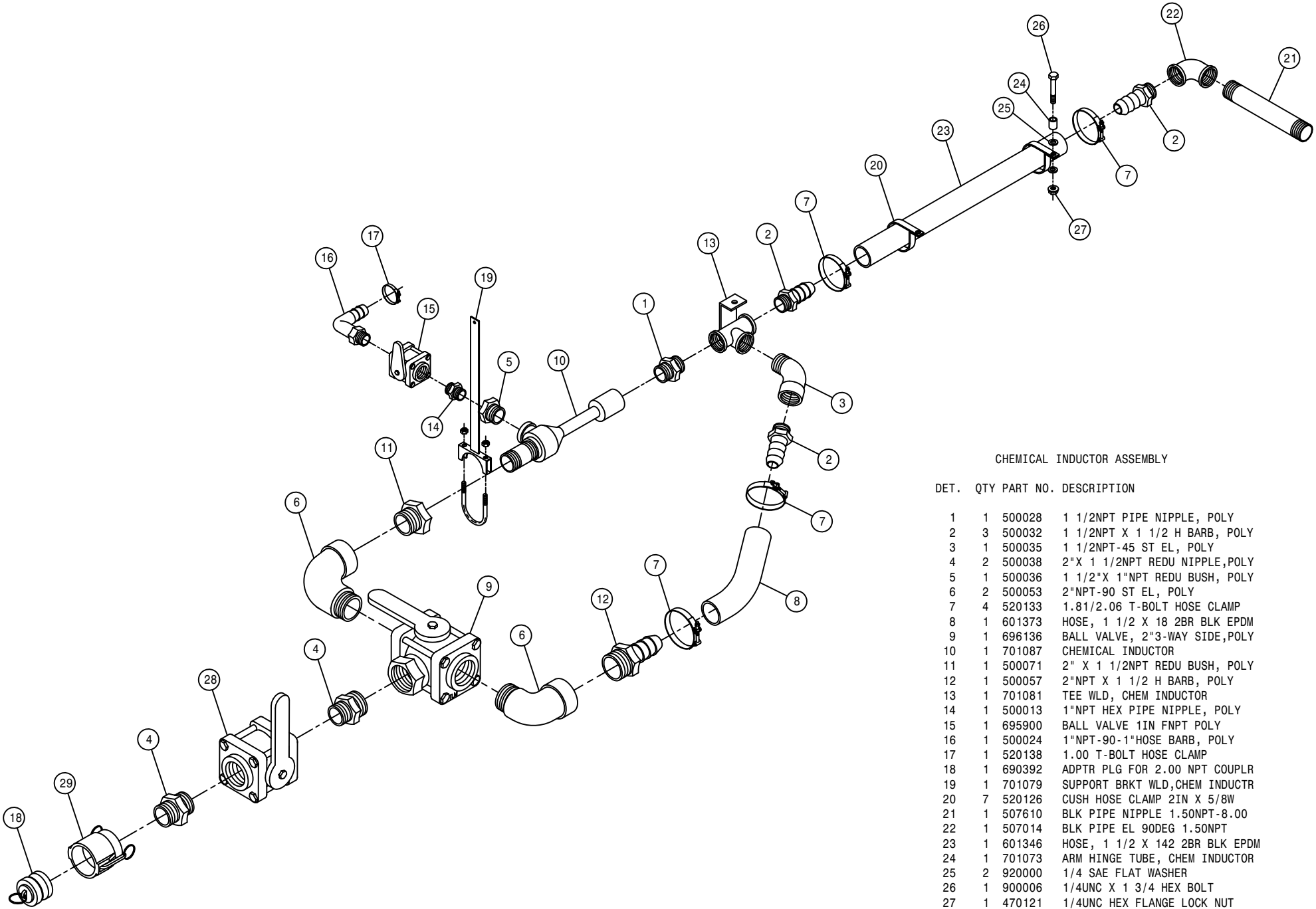

CHEMICAL INDUCTOR ASSEMBLY

DET.	QTY	PART NO.	DESCRIPTION
1	1	500028	1 1/2NPT PIPE NIPPLE, POLY
2	3	500032	1 1/2NPT X 1 1/2 H BARB, POLY
3	1	500035	1 1/2NPT-45 ST EL, POLY
4	2	500038	2" X 1 1/2NPT REDU NIPPLE, POLY
5	1	500036	1 1/2" X 1" NPT REDU BUSH, POLY
6	2	500053	2" NPT-90 ST EL, POLY
7	4	520133	1.81/2.06 T-BOLT HOSE CLAMP
8	1	601373	HOSE, 1 1/2 X 18 2BR BLK EPDM
9	1	696136	BALL VALVE, 2" 3-WAY SIDE, POLY
10	1	701087	CHEMICAL INDUCTOR
11	1	500071	2" X 1 1/2NPT REDU BUSH, POLY
12	1	500057	2" NPT X 1 1/2 H BARB, POLY
13	1	701081	TEE WLD, CHEM INDUCTOR
14	1	500013	1" NPT HEX PIPE NIPPLE, POLY
15	1	695900	BALL VALVE 1IN FNPT POLY
16	1	500024	1" NPT-90-1" HOSE BARB, POLY
17	1	520138	1.00 T-BOLT HOSE CLAMP
18	1	690392	ADPTR PLG FOR 2.00 NPT COUPLR
19	1	701079	SUPPORT BRKT WLD, CHEM INDUCTR
20	7	520126	CUSH HOSE CLAMP 2IN X 5/8W
21	1	507610	BLK PIPE NIPPLE 1.50NPT-8.00
22	1	507014	BLK PIPE EL 90DEG 1.50NPT
23	1	601346	HOSE, 1 1/2 X 142 2BR BLK EPDM
24	1	701073	ARM HINGE TUBE, CHEM INDUCTOR
25	2	920000	1/4 SAE FLAT WASHER
26	1	900006	1/4UNC X 1 3/4 HEX BOLT
27	1	470121	1/4UNC HEX FLANGE LOCK NUT
28	1	696110	BALL VALVE 1 1/2FNPT POLY
29	1	690390	2.00 FEMALE NPT COUPLER

SOLUTION HOISING FOR 60' BOOM

DET. QTY PART NO. DESCRIPTION

DET.	QTY	PART NO.	DESCRIPTION
1	1	601317	HOSE, 1 IN 1BR BLK EPDM X 93
2	1	601318	HOSE, 1 IN 1BR BLK EPDM X 254
3	1	601319	HOSE, 1 IN 1BR BLK EPDM X 336
4	1	601240	HOSE, 1.50 X 84 2F1W EPDM
5	1	601307	HOSE, 1.50 X 118 2F1W EPDM
6	1	601329	HOSE, 1.50 X 130 2F1W EPDM
7	2	690412	HOSE SPRING GUARD 2IN X 12 LG
8	2	690396	HOSE SPRING GUARD 2IN X 48 LG
9	1	601217	HOSE, 1.50 X 24 2F1W EPDM

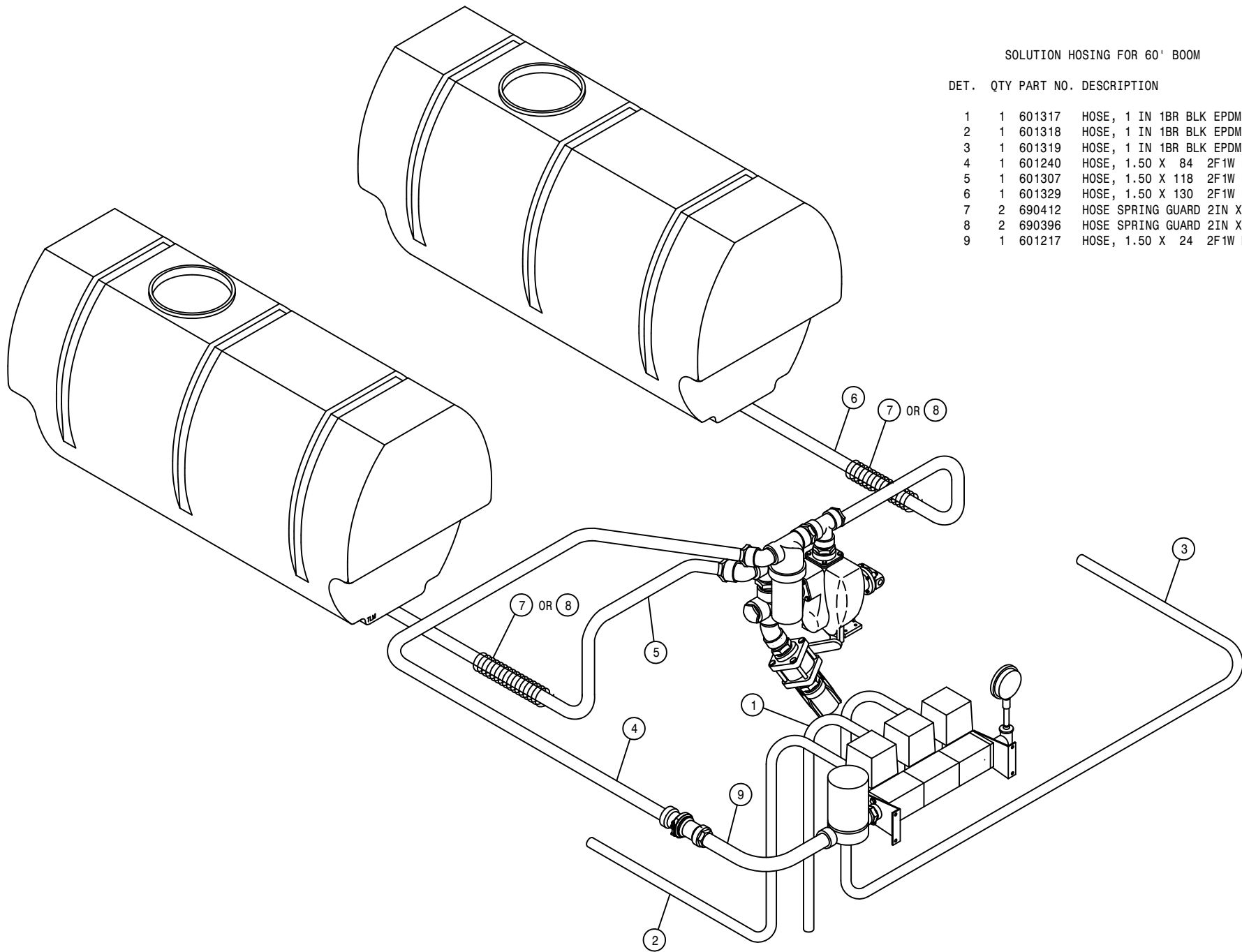

100

191100

SOLUTION HOISING FOR 80' -90' BOOM

DET. QTY PART NO. DESCRIPTION

DET.	QTY	PART NO.	DESCRIPTION
1	1	601317	HOSE, 1 IN 1BR BLK EPDM X 93
2	1	601318	HOSE, 1 IN 1BR BLK EPDM X 254
3	1	601319	HOSE, 1 IN 1BR BLK EPDM X 336
4	1	601391	HOSE, 1 IN 1BR BLK EPDM X 274
5	1	601307	HOSE, 1.50 X 118 2F1W EPDM
6	1	601329	HOSE, 1.50 X 130 2F1W EPDM
7	2	690412	HOSE SPRING GUARD 2IN X 12 LG
8	2	690396	HOSE SPRING GUARD 2IN X 48 LG
9	2	601390	HOSE, 1 IN 1BR BLK EPDM X 160
10	1	601392	HOSE, 1 IN 1BR BLK EPDM X 356
11	1	601240	HOSE, 1.50 X 84 2F1W EPDM
12	1	601217	HOSE, 1.50 X 24 2F1W EPDM

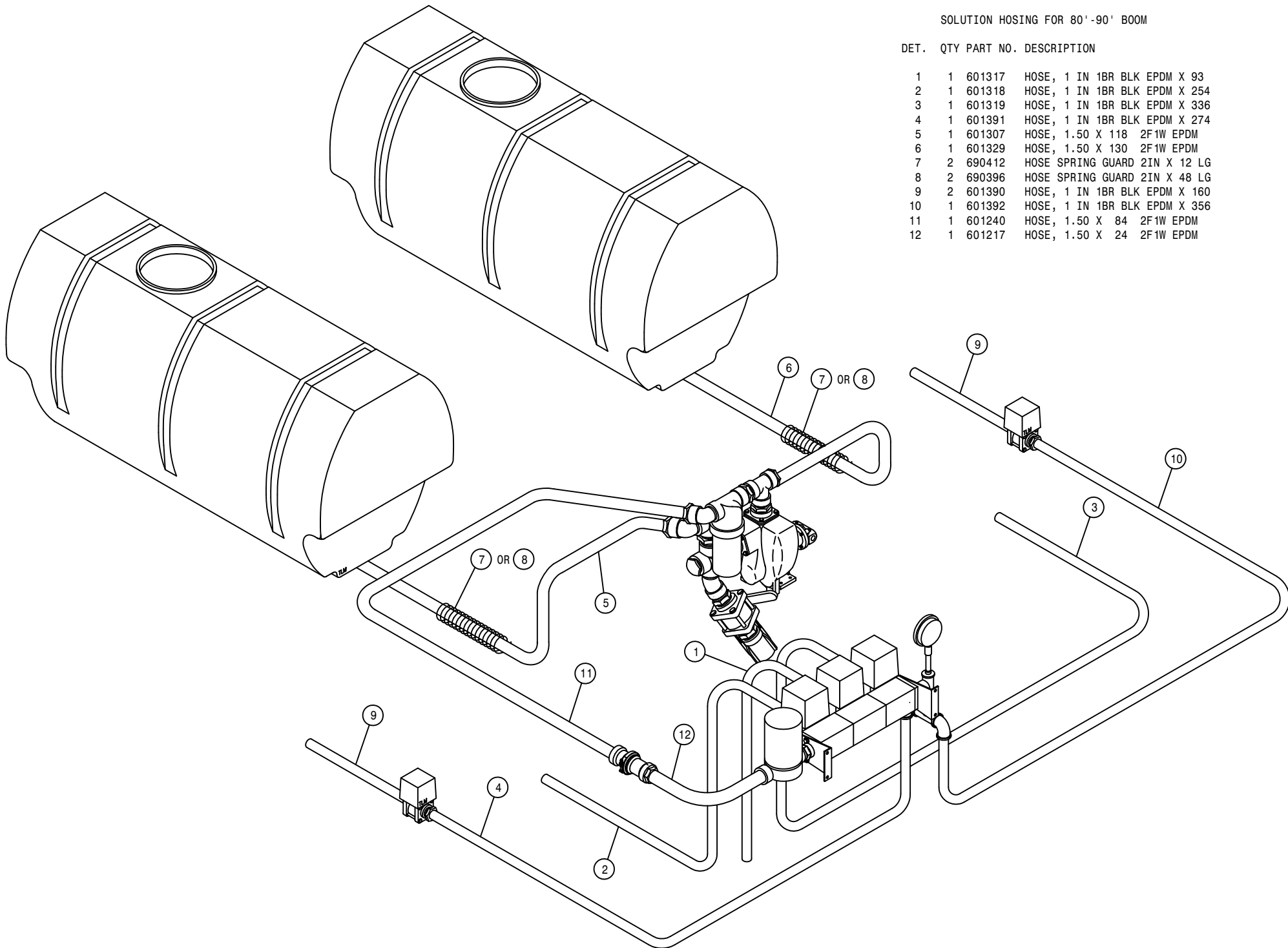

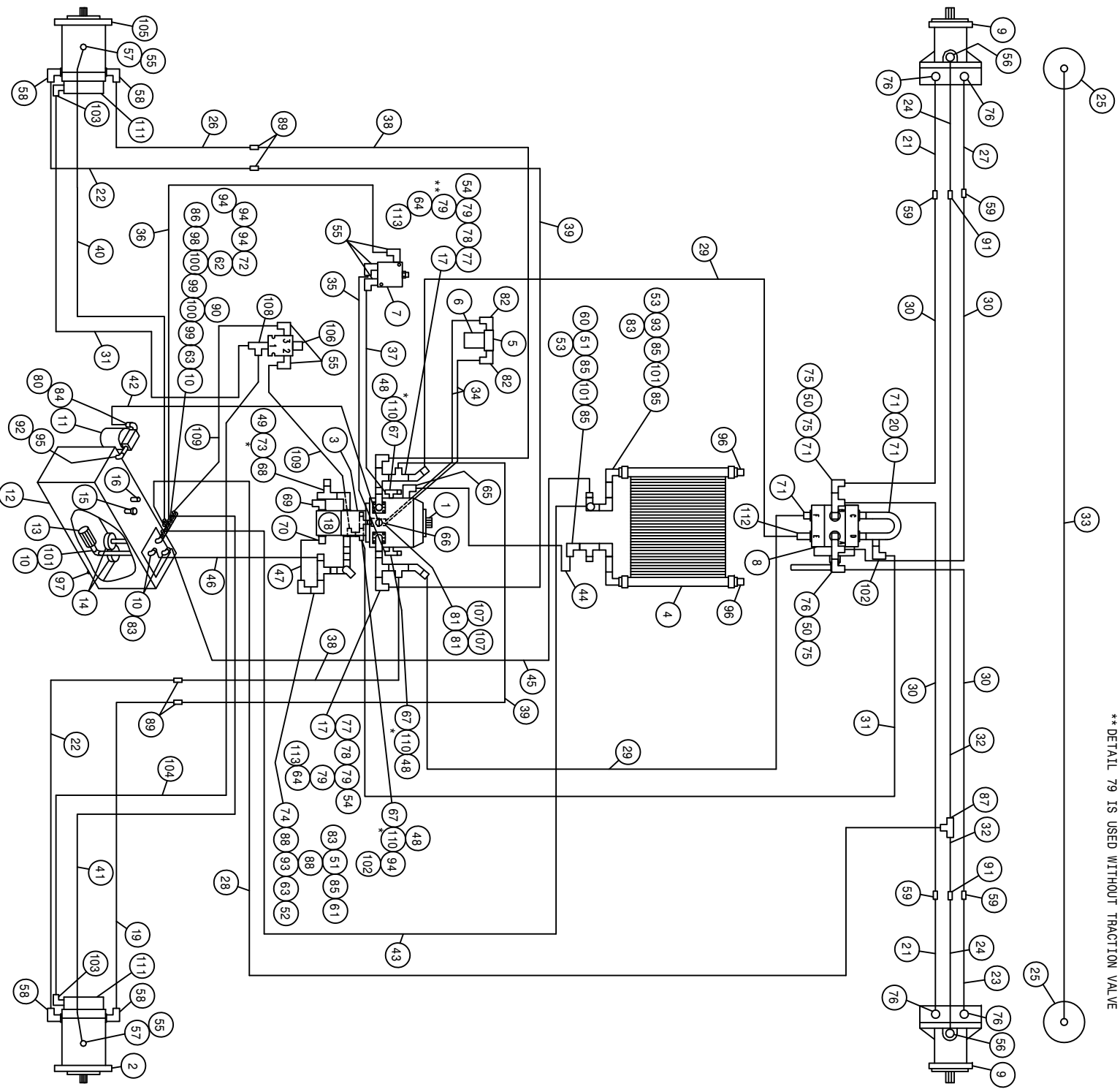

*NOTE:
 REFER TO DETAIL 73 TO CHECK AUX. SYSTEM - 1880 PSI
 REFER TO DETAIL 110 TO CHECK LIMIT SETTING - 4500 PSI
 REFER TO DETAIL 110 TO CHECK CHARGE PRESSURE - 380 PSI
 **DETAIL 79 IS USED WITHOUT TRACTION VALVE

284 HYDRAULIC SCHEMATIC 99
REFERENCE DRAWING NO. 498553S1

DET.	QTY	PART NO.	DESCRIPTION	DET.	QTY	PART NO.	DESCRIPTION
1	1	606954	SUND 130CC PUMP,B-MT	98	58		
2	1	610557	SUND M35-.3102 WHL MTR W/SHFT	59	4	618576	1 5/16MJIC-90-1 1/16MOR LBO
3	1	606932	SUND GEAR PUMP,1.60CI,SPLINED	60	1	618138	1IN HOSE BARB-90-1MNP
4	1	618606	OTL COOLER, BLISSFIELD 65027	61	1	716000	3/4 HOSE BARB-90-1MNP
5	1	605608	HYD FILTER HEAD, DONALDSON	62	1	504001	RED BUSH 3/4 X 1/4 BLK MAL
6	1	605609	HYD FILTER ELEMENT, DONALDSON	63	2	505213	RED BUSH 1 X 3/4 BLK MAL
7	1	610580	REMOTE FLUSHING VALVE, SUND	64	1	618630	1 5/16MJ-45-1 5/16FJ SWIV LBO
8	1	606003	GRESSEN SELECTOR VALVE DS-12	65	1	618564	1IN HOSE BARB-90-1 5/16MOR
9	2	610571	SUND M35-3002 WHL MTR	66	1	618626	1 1/4 HOSE BARB-45-1 5/8MOR
10	4	505300	BLK PIPE EL 90DEG 1.00NPT	67	3	618126	9/16MJIC-9/16MOR ADPTR
11	1	605601	GRESSEN FILTER 10 MICRON 40GPM	68	1	618535	7/8MJIC-90-1 1/16MOR LBO
12	1	760097	OTL TANK WLD 8240 1982	69	1	611128	7/8MJIC-90-7/8MOR LBO
13	1	605600	MICHIGAN RESERVOIR FILTER	70	1	618075	3/4 HOSE BARB-1 1/16MOR
14	2	605603	LINE SUMP DIFFUSER	71	4	611127	1 1/16MJIC-1 1/16MOR ADPTR
15	1	611052	FILLER BREATHER 3/4NPT	72	1	618520	1/4MNP RUN TEE-9/16MJIC
16	1	614453	DIPSTICK, 8IN	73	1	618333	7/8FJIC SW RUN TEE-7/8MJIC
17	2	618461	1 1/4 SPLIT FLANGE KIT	74	1	618090	1 5/16MOR-1FNPT ADPTR
18	1	606929	SUND GEAR PUMP .66CI, SPLINED	75	3	618191	1 1/16MJ-90-1 1/16FJ SWIV LBO
19	1	615706	RH REAR LEG HYDTUBE ASSY284 97	76	5	618248	1 1/16MJIC-90-1 1/16MOR LBO
20	1	614290	FWD UTUBE 472 P/C 1977 18WHMT	77	2	618459	1 1/4FLANGE-90-1 5/8MJIC
21	2	615702	FRT LEG INR HYD TUBE ASSY28496	78	2	618547	1 5/8FJIC-1 5/16MJIC ADPTR
22	2	615705	REAR LEG HYD TUBE ASSY 284 97	79	4	618619	1 5/16FJ SW RUN TEE-15/16MJ
23	1	615703	RH FRTLEG OUTRHDTUBE ASY28496	80	1	506410	BLK PIPE ST EL 90DEG 1.25NPT
24	2	615656	FRT LEG CNTR HYD TUBE ASSY284	81	2	618327	3/4MJIC-7/8MOR ADPTR
25	2	620570	HYD CYL LEG LEVEL 2.00 X 12	82	2	618474	3/4MJIC-90-1 1/16MOR LBO
26	1	615707	LH REAR LEG HYDTUBE ASSY284 97	83	4	714560	INPT X 1 HOSE BARB
27	1	615704	LH FRTLEG OUTRHDTUBE ASY28496	84	1	715660	HOSE BARB 1 1/4NPT X 1 1/4
28	1	614704	06C1T-06FJX-06FJX-156	85	5	505200	BLK PIPE ST EL 90DEG 1.00NPT
29	2	614724	12TWM-12FJX-12FJX-106	86	1	618018	9/16MJIC-1/2MNP ADPTR
30	4	614725	12C2AT-12FJX-12FJX-70	87	1	618019	9/16MJIC UNION TEE
31	2	614101	04C1T-06FJX-06FJX-133	88	2	505105	1MNP HEX PIPE NIPPLE STL
32	2	615444	06C1T-06FJX-08FJX90-60	89	4	618441	1 5/16MJIC-90-1 5/16MJIC LBO
33	1	615614	FRT LEG CYL JUMPER HOSE280 89	90	1	713220	HOSE BARB 3/4 NPT X 3/4
34	2	615465	08C1T-08FJX-08FJX-33	91	2	618314	3/4MJIC UNION
35	1	616042	04C1T-06FJX-06FJX-13	92	1	506602	PIPE NIPPLE 1 1/4NPT-2 1/2
36	1	616048	04C1T-06FJX-06FJX-35	93	2	505098	SIDE OUTLET EL 90DEG 1.00NPT
37	1	616043	04C1T-06FJX-06FJX-23	94	4	618486	9/16FJIC SW RUN TEE-9/16MJIC
38	2	614727	12TWM-16FJX-16FJX-50	95	1	506303	BLK PIPE EL 90DEG 1.25NPT
39	2	614729	12TWM-16FJX-16FJX-65	96	2	505102	PIPE PLUG 1.00NPT SQ HD
40	1	614549	06C1T-06FJX-06FJX-140	97	1	501102	1/4 PIPE PLUG
41	1	615449	06C1T-06FJX-06FJX-126	98	1	504210	RED BUSH 3/4 NPT X 1/2 NPT
42	1	601380	HOSE, 1 1/4 X 35 1FBR-1SPI	99	2	504702	CLOSE NIPPLE .75NPT
43	1	601401	HOSE, 3/4 X 88 1FBR-1SPI	100	2	504955	BLK PIPE TEE .75NPT
44	1	601403	HOSE, 1 X 72 1FBR-1SPI	101	3	505203	BLK PIPE NIPPLE 1.00NPT-4.00
45	1	601404	HOSE, 1 X 87 1FBR-1SPI	102	2	618618	9/16MJIC-90-9/16FJIC SWIV LBO
46	1	601402	HOSE, 1 X 53 1FBR-1SPI	103	2	618114	9/16MJIC-90-7/16MOR LBO
47	1	601383	HOSE, 3/4 X 8 1FBR-1SPI	104	1	614639	04C1T-06FJX-06FJX-126
48	3	618531	9/16FJIC CAP NUT	105	1	610621	SUND HYD MOTOR
49	1	618328	7/8FJIC CAP NUT	106	1	610318	HYD SOLE VLV,2P-3W,9/16FOR,12V
50	2	618487	1 1/16FJ SW RUN TEE-1 1/16MJ	107	2	618609	3/4MJIC-90-3/4FJIC SWIV LBO
51	2	505101	BLK PIPE TEE 1.00NPT	108	1	618444	9/16MOR RUN TEE-9/16MJIC
52	1	610300	3/4MJIC-3/4MNP ADPTR	109	2	616056	04C1T-06FJX-06FJX-32
53	2	714331	1 NPT X 3/4 HOSE BARB	110	3	618514	9/16FJ SW BRANCH TEE-9/16MJ
54	2	618640	1 5/16MJ-90-1 5/16FJ SWIV LBO	111	2	828092	MICO HYD BRAKE
55	7	618119	9/16MJIC-90-9/16MOR LBO	112	1	607527	FLOW CTRL VALVE,32GPM IN-LINE
56	2	618183	3/4MJIC-90-7/8MOR LBO	113	2	618541	1 5/16FJIC-1 1/16MJIC ADPTR
57	2	618172	7/8MOR-9/16FOR ADPTR				

284 HYDRAULIC SCHEMATIC 99
REFERENCE DRAWING NO. 498553S2

DET.	QTY	PART NO.	DESCRIPTION	DET.	QTY	PART NO.	DESCRIPTION
1	2	610510	CESSNA GEAR MOTOR 1.48CI	29	2	611122	9/16MJIC-90-1/4MNPT LBO
2	1	690573	HYD MOTOR, FLOMAX HI-SPEED	30	2	618338	9/16MJIC-45-1/4MNPT LBO
3	1	610447	HYD FILTER, INLINE 1/4FNPT 90M	31	2	611147	3/4MJIC-1/2MNPT ADPTR
4	1	606827	FLO CONT FCS1 0-3 VARI 7/8FOR	32	3	503820	BLK PIPE TEE .50NPT
5	2	620080	STRG CYL ASSY 1.50 X 6.0 1985	33	3	618018	9/16MJIC-1/2MNPT ADPTR
6	1	606818	FLO CONT FCR51 0-16GPM 7/8FOR	34	1	503600	CLOSE NIPPLE .50NPT
7	2	607512	RELIEF VALVE, RL50, 1850 PSI	35	5	618514	9/16FJ SW BRANCH TEE-9/16MJ
8	1	607504	FLO DIV B50 2-8GPM 7/8 FOR	36	5	618486	9/16FJIC SW RUN TEE-9/16MJIC
9	1	610569	6 SECT, 5 FUNCTN HYD VLV, EATON	37	1	618325	7/8MJIC-1/2MNPT ADPTR
10	1	749150	STRG MTR NON-LOAD REACT 1008	38	1	712440	1/2 NPT X 3/4 HOSE BARB
11	2	614664	10C1T-10FJX-10FJX-98	39	2	618310	9/16MJIC-7/8MOR ADPTR
12	3	614693	06C1T-06FJX-06FJX-168	40	3	618618	9/16MJIC-90-9/16FJIC SWIV LBO
13	1	614159	04C1T-06FJX-06FJX-169	41	1	618172	7/8MOR-9/16FOR ADPTR
14	4	614663	04C1T-06FJX-06FJX-16	42	12	618119	9/16MJIC-90-9/16MOR LBO
15	2	616028	04C1T-06FJX-06FJX-47	43	1	618327	3/4MJIC-7/8MOR ADPTR
16	1	611204	04C1T-06FJX-06FJX-78	44	1	618440	9/16MJIC-90-9/16MOR EX LG LBO
17	1	616040	04C1T-06FJX-06FJX-67	45	3	618126	9/16MJIC-9/16MOR ADPTR
18	3	616026	08C1T-06FJX-08FJX-37	46	1	611128	7/8MJIC-90-7/8MOR LBO
19	1	616057	08C1T-08FJX-08FJX-88	47	2	611126	7/8MJIC-7/8MOR ADPTR
20	1	614571	06C1T-06FJX-06FJX-126	48	3	611121	9/16MJIC-1/4MNPT ADPTR
21	2	611208	04C1T-06FJX-06FJX-98	49	4	618092	1 1/16MOR-1/2FNPT ADPTR
22	1	615452	06C1T-06FJX-06FJX-16	50	8	618107	9/16MJIC-90-1/2MNPT LBO
23	1	615521	10C1T-10FJX-10FJX-18	51	1	618562	9/16MOR-90-1/4MNPT LBO
24	1	615465	08C1T-08FJX-08FJX-33	52	2	500000	1/2MNPT HEX PIPE NIPPLE STL
25	1	614662	08C1T-08FJX-08FJX-72	53	2	618072	7/8MOR-1/2FNPT ADPTR
26	1	601384	HOSE, 3/4 X 40 1FBR-1SPI	54	2	618531	9/16FJIC CAP NUT
27	4	618496	9/16MJIC-45-3/4MOR LBO	55	2	618609	3/4MJIC-90-3/4FJIC SWIV LBO
28	3	618019	9/16MJIC UNION TEE	56	2	618241	3/4MJIC-90-3/4MOR LBO

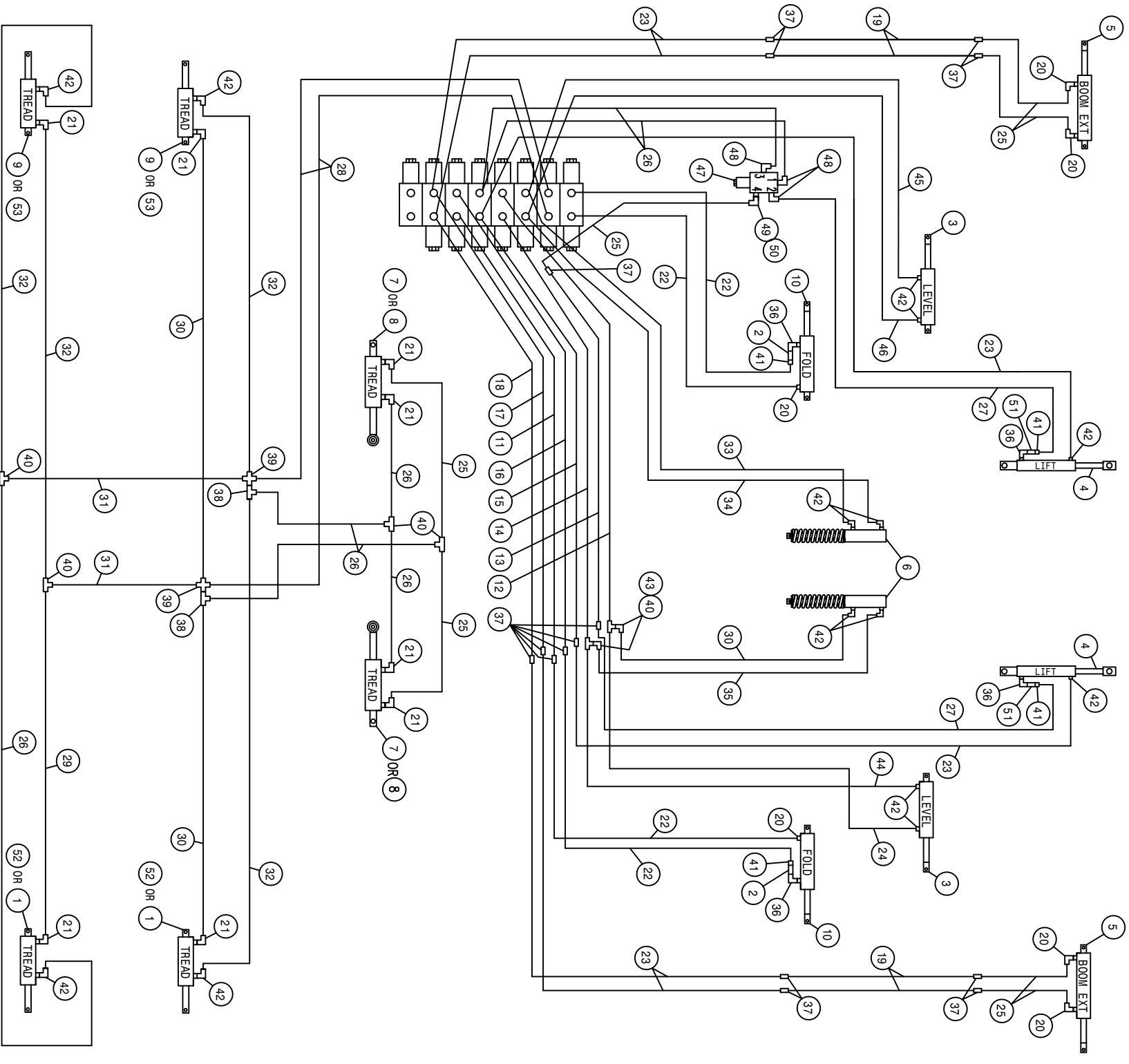

284 HYDRAULIC SCHEMATIC 99
REFERENCE DRAWING NO. 49855353

DET.	QTY	PART NO.	DESCRIPTION	DET.	QTY	PART NO.	DESCRIPTION	
1	2	620120	CYL ASSY, RH LEG, TREAD ADJ 94	28	2	611210	04C1T-06FJX-06FJX-156	H/A
2	2	610450	RESTRICTOR .025 1-WAY, 1/2FNP	29	1	616042	04C1T-06FJX-06FJX-13	H/A
3	2	620585	LEVEL CYL ASSY, 2 X 10	30	3	616049	04C1T-06FJX-06FJX-26	H/A
4	2	620701	LIFT CYL ASSY, 2.50 X 14.00" 99	31	2	614308	04C1T-06FJX-06FJX-109	H/A
5	2	620664	CYL ASSY, BOOM FOLD 2.50X18" 98	32	4	616026	04C1T-06FJX-06FJX-37	H/A
6	2	620632	ACCUMULATOR CYL ASSY	33	1	616037	04C1T-06FJX-06FJX-29	H/A
7	2	620123	CYL ASSY, STRG, 125" TREAD ADJ 94	34	1	614713	04C1T-06FJX-06FJX-24	H/A
8	2	620122	CYL ASSY, STRG, 90" TREAD ADJ 94	35	1	614712	04C1T-06FJX-06FJX-20	H/A
9	2	620121	CYL ASSY, LH LEG, TREAD ADJ 94	36	4	618633	1/2MNP-90-1/4MNP REDU LBO	H/A
10	2	620652	FOLD CYL ASSY, 2 X 10 IN	37	15	619010	9/16MJIC UNION	
11	1	615641	FOLD HYD TUBE ASSY, IN 254/284	38	2	618486	9/16FJIC SW RUN TEE-9/16MJIC	
12	1	615639	LEVEL HYD TUBE ASSY, UP254/284	39	2	618320	9/16MJIC UNION CROSS	
13	1	615637	LIFT HYD TUBE ASSY, UP 254/284	40	6	618019	9/16MJIC UNION TEE	
14	1	615640	LEVEL HYD TUBE ASSY, DN254/284	41	4	618018	9/16MJIC-1/2MNP ADPTR	
15	1	615638	LIFT HYD TUBE ASSY, DN 254/284	42	14	611122	9/16MJIC-90-1/4MNP LBO	
16	1	615642	FOLD HYD TUBE ASSY, OUT254/284	43	2	618618	9/16MJIC-90-9/16FJIC SWIV LBO	
17	1	615683	FOLD BOOM HYD TUBE ASSY, OUT	44	1	614714	04C1T-06FJX-06FJX-34	H/A
18	1	615682	FOLD BOOM HYD TUBE ASSY, IN	45	1	614715	04C1T-06FJX-06FJX-43	H/A
19	4	615684	HYD TUBE ASSY, BOOM EXT FOLD96	46	1	616059	04C1T-06FJX-06FJX-33	H/A
20	6	614365	RESTRICTOR ELBOW ASSY .042DIA	47	1	610628	4-WAY, 2-POSITION SOL VLV	
21	8	614710	RESTRICTOR ELBOW ASSY .025DIA	48	3	618115	9/16MJIC-90-3/4MOR LBO	
22	4	615442	04C1T-06FJX-06FJX-55	49	1	618109	9/16MJIC-3/4MOR ADPTR	
23	6	616040	04C1T-06FJX-06FJX-67	50	1	618618	9/16MJIC-90-9/16FJIC SWIV LBO	
24	1	616028	04C1T-06FJX-06FJX-47	51	2	610675	RESTRICTOR, .042 1-WAY, 1/2FNP	
25	7	616043	04C1T-06FJX-06FJX-23	52	2	620659	CYL ASSY, TRD ADJ, RH284, LH2100	
26	7	614663	04C1T-06FJX-06FJX-16	53	2	620662	CYL ASSY, TRD ADJ, LH284, RH2100	
27	2	615616	04C1T-06FJX-06FJX-65					H/A

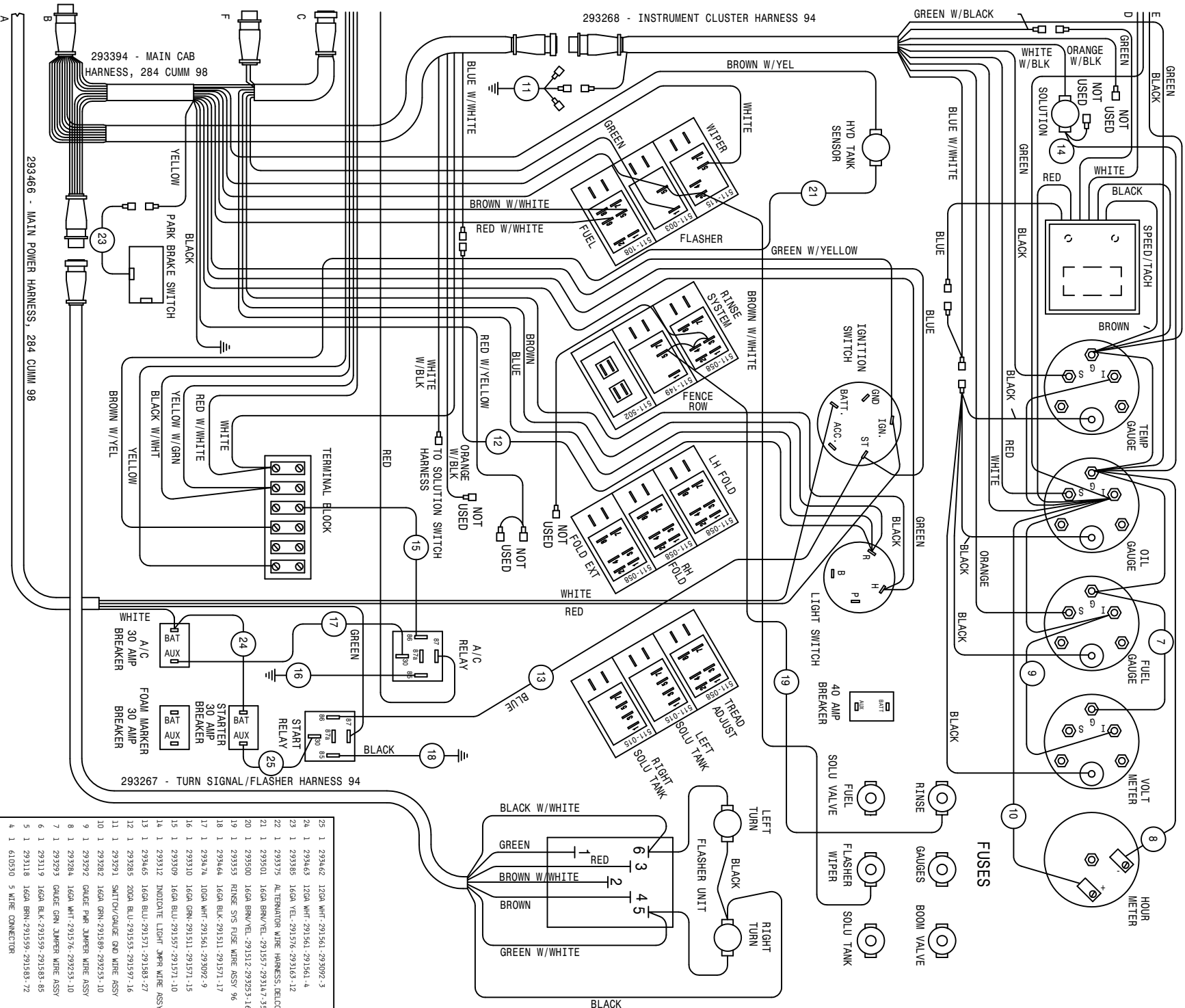

25	1	293462	12GA WHT-291561-293092-3
24	1	293463	12GA WHT-291561-291564-4
23	1	293385	16GA YEL-291576-293163-12
22	1	293375	ALTERNATOR WIRE HARNESS, DELCO
21	1	293501	16GA BRN/YEL-291571-293147-35
20	1	293500	16GA BRN/YEL-291512-292953-16
19	1	293353	RINSE SYS FUSE WIRE ASSY 96
18	1	293464	16GA BLK-291511-291571-17
17	1	293474	10GA WHT-291561-293092-9
16	1	293310	16GA GRN-291511-291571-15
15	1	293309	16GA BLU-291597-291571-10
14	1	293312	INDICATE LEDHT 3MR WIRE ASSY
13	1	293465	16GA BLU-291571-291583-27
12	1	293285	20GA BLU-291533-291597-16
11	1	293291	SWITCH/GAUGE GND WIRE ASSY
10	1	293282	16GA GRN-291569-292953-10
9	1	293292	GAUGE PWR JAMPER WIRE ASSY
8	1	293284	16GA WHT-291576-292953-10
7	1	293293	GAUGE GRN JAMPER WIRE ASSY
6	1	293119	16GA BLK-291599-291583-85
5	1	293118	16GA BRN-291599-291583-72
4	1	610530	5 WIRE CONNECTOR
3	1	291029	10GA BLU-291513-291587-30
2	1	291128	BATTERY CABLE 48IN
1	1	291530	BATTERY GROUND CABLE 23

SHEET 1 OF 5
REVISION DATE: 07-20-01
498544

SOLUTION SOLENOID VALVES

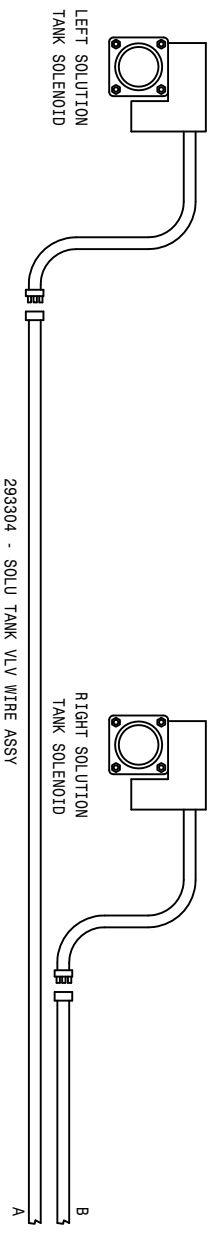
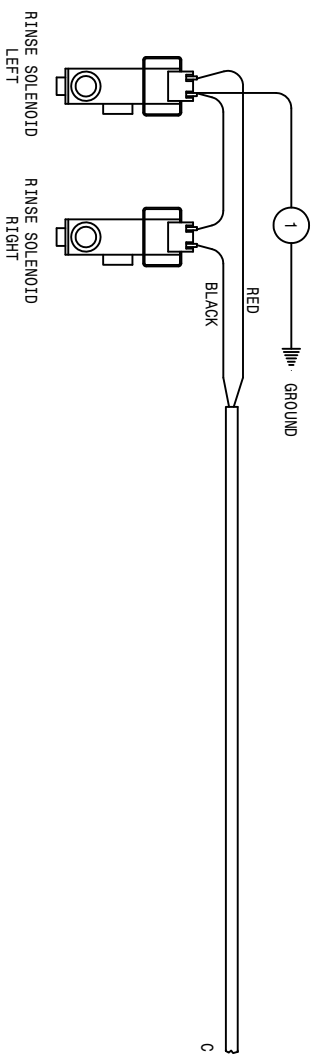

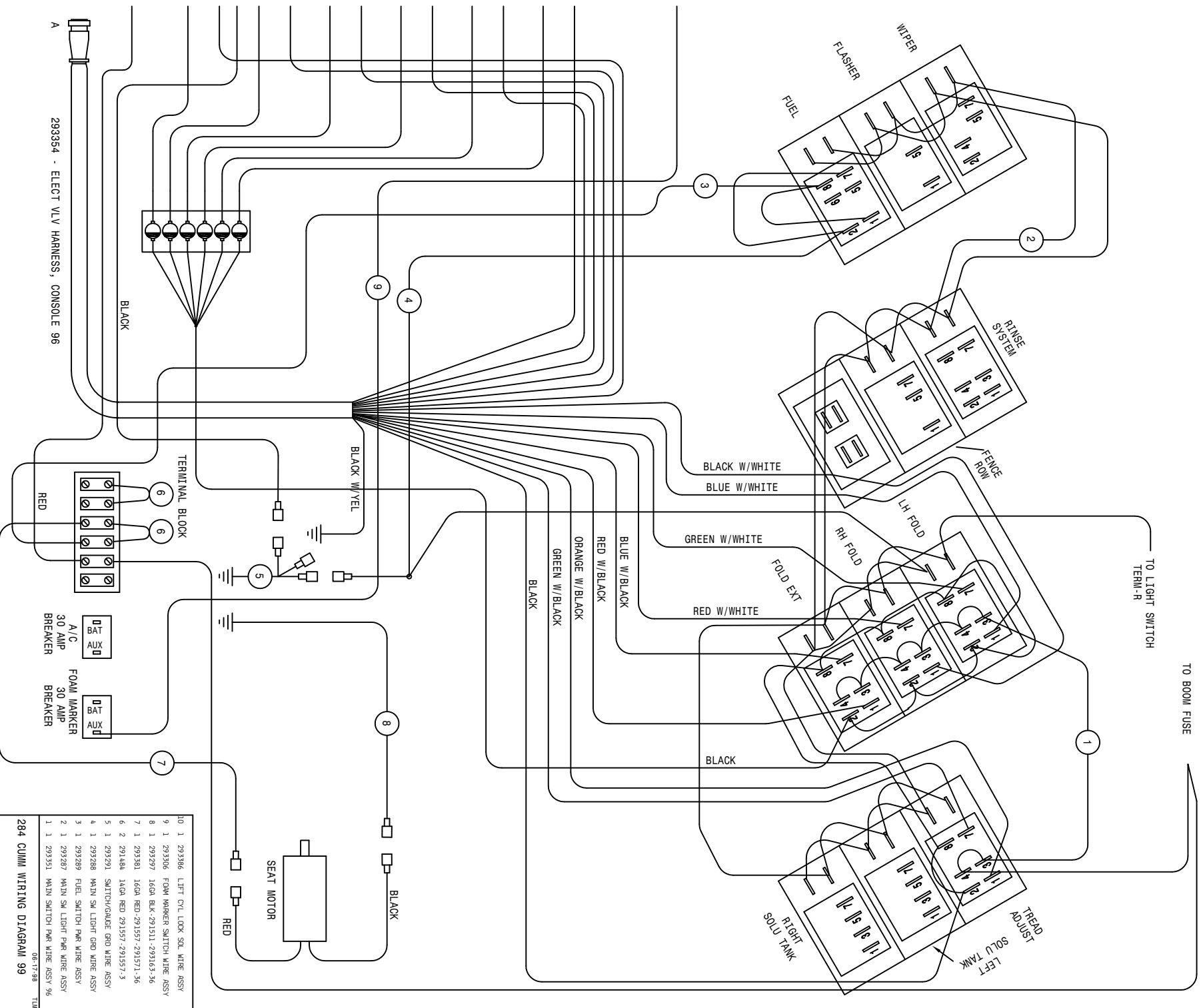

293354 - ELECT VLV HARNESS, CONSOLE 96

BLACK

TERMINAL BLOCK

BLACK W/VEL

RED

A/C
30 AMP
BREAKER

FOAM MARKER
30 AMP
BREAKER

7

SEAT MOTOR

8

BLACK

9

BLACK

4

9

BLACK W/WHITE
BLUE W/WHITE

GREEN W/WHITE

RED W/WHITE

BLACK

BLUE W/BLACK
RED W/BLACK
ORANGE W/BLACK
GREEN W/BLACK
BLACK

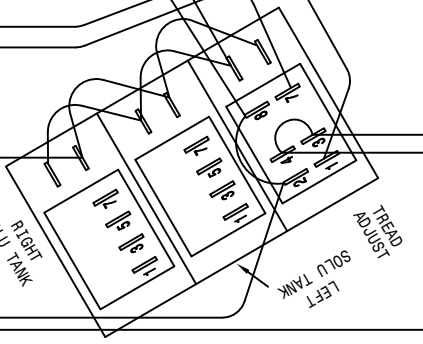
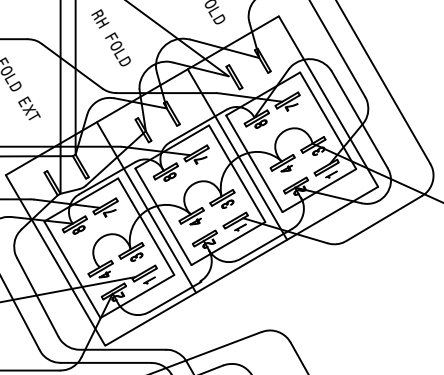
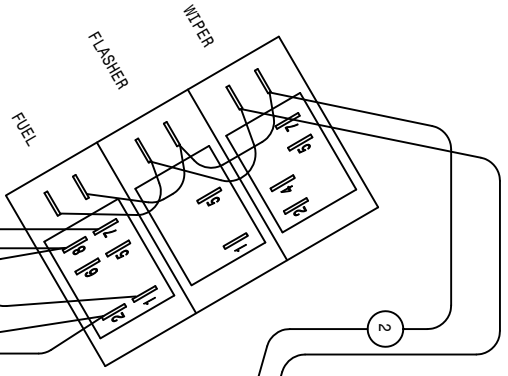

TO LIGHT SWITCH
TERM-R

TO BOOM FUSE

TREAD
ADJUST

100	1	293386	LIFT CYL LOCK SOL. WIRE ASSY
99	1	293306	FOAM MARKER SWITCH WIRE ASSY
8	1	293297	16GA BLK -293163-36
7	1	293381	16GA RED-293157-36
6	2	291484	14GA RED-29157-3
5	1	293291	SWITCH/GALDE GRD WIRE ASSY
4	1	293288	MAIN SW LIGHT GRD WIRE ASSY
3	1	293289	FUEL SWITCH PWR WIRE ASSY
2	1	293287	MAIN SW LIGHT PWR WIRE ASSY
1	1	293351	MAIN SWITCH PWR WIRE ASSY 96

284 CUMM WIRING DIAGRAM 99
06-17-88 TLM
498544
SHEET 3 OF 5
REVISION DATE: 06-07-88

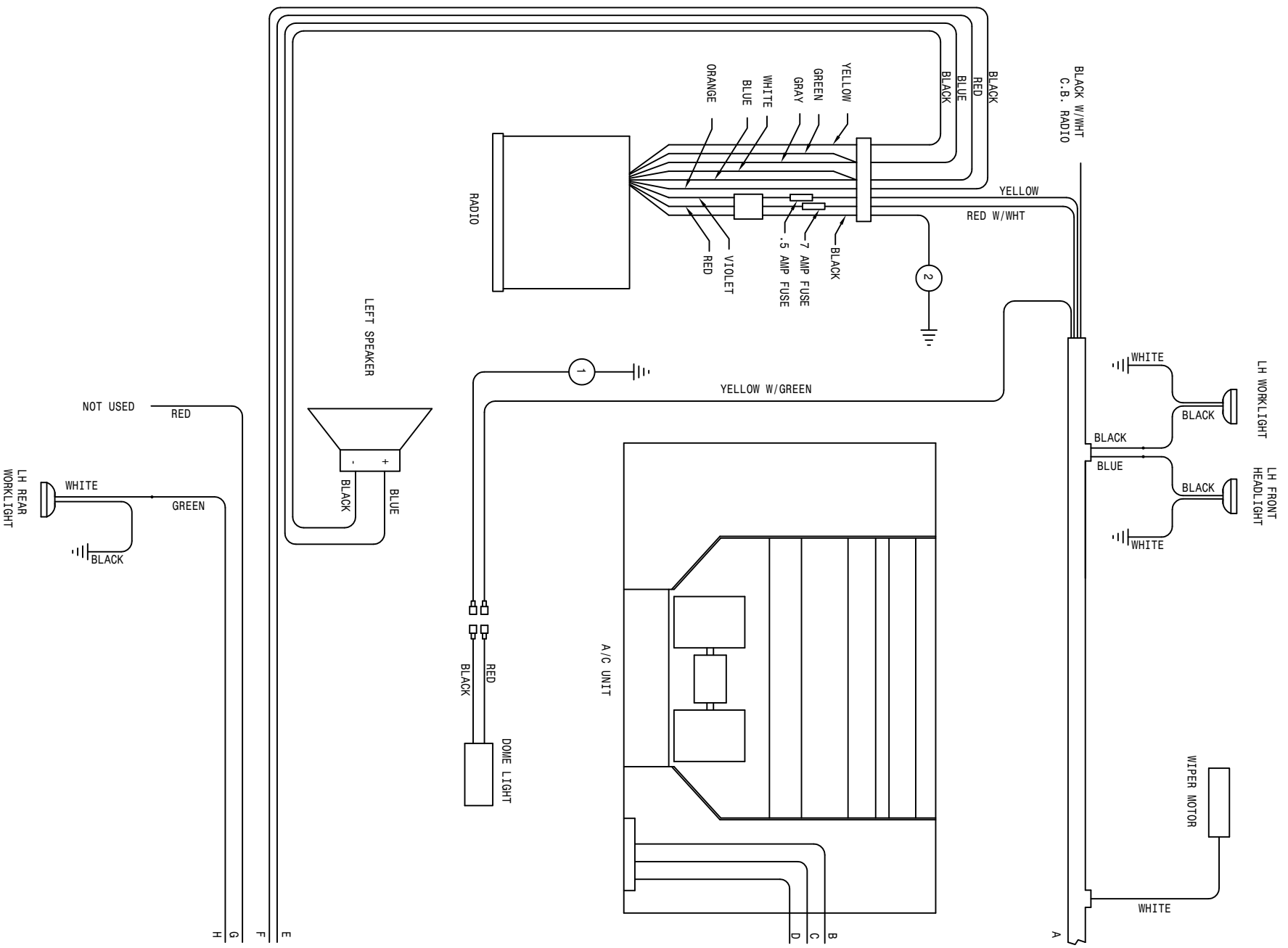

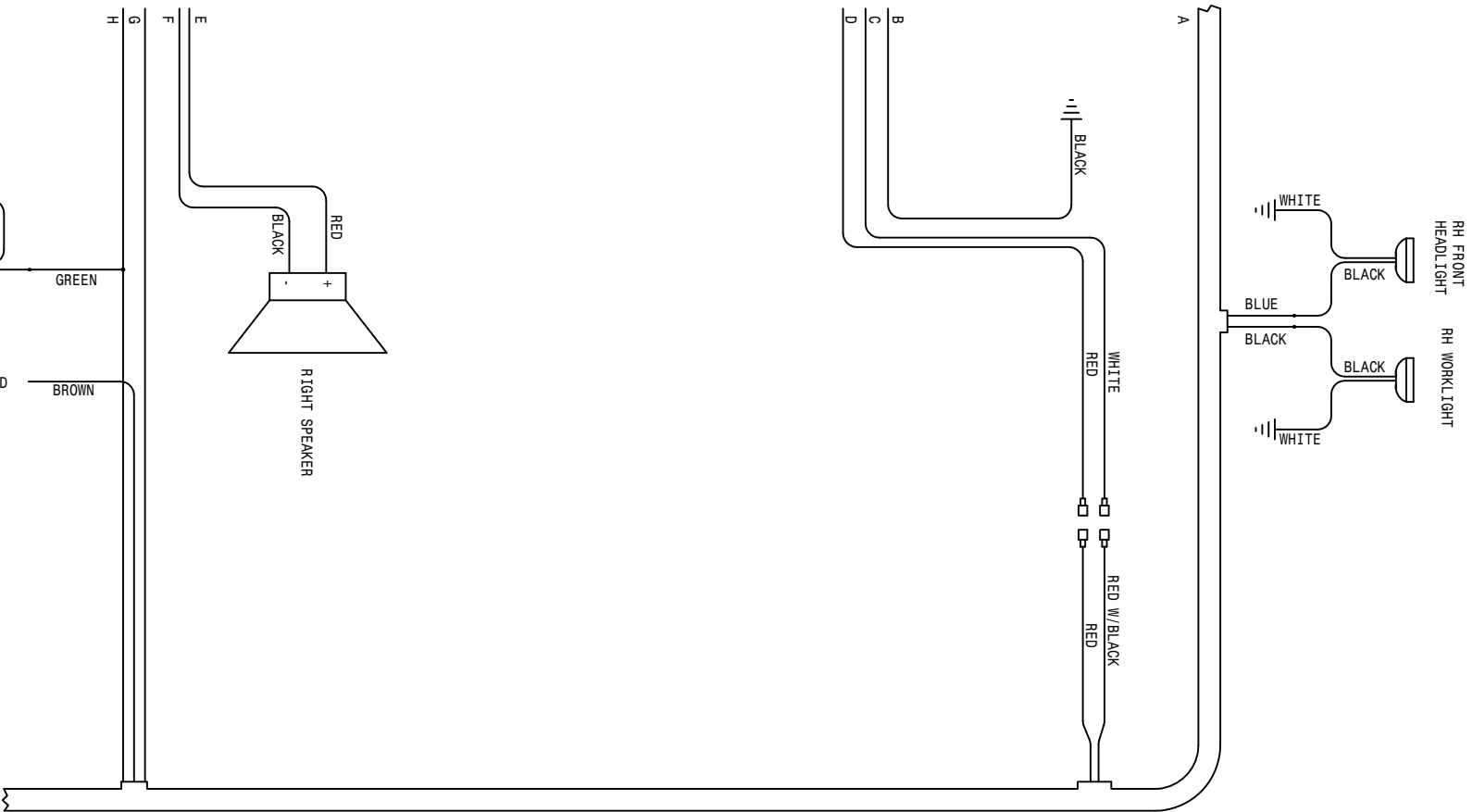

293473 - CAB WIRE HARNESS

REFER TO SHEET 1 OF 4

2	1	293300	16GA BLK-291511-291571-18
1	1	293299	16GA BLK-291511-291571-30
284 CUMM WIRING DIAGRAM 99			
SHEET 4 OF 5			
REVISION DATE:			
06-17-88 TLU			
498544			

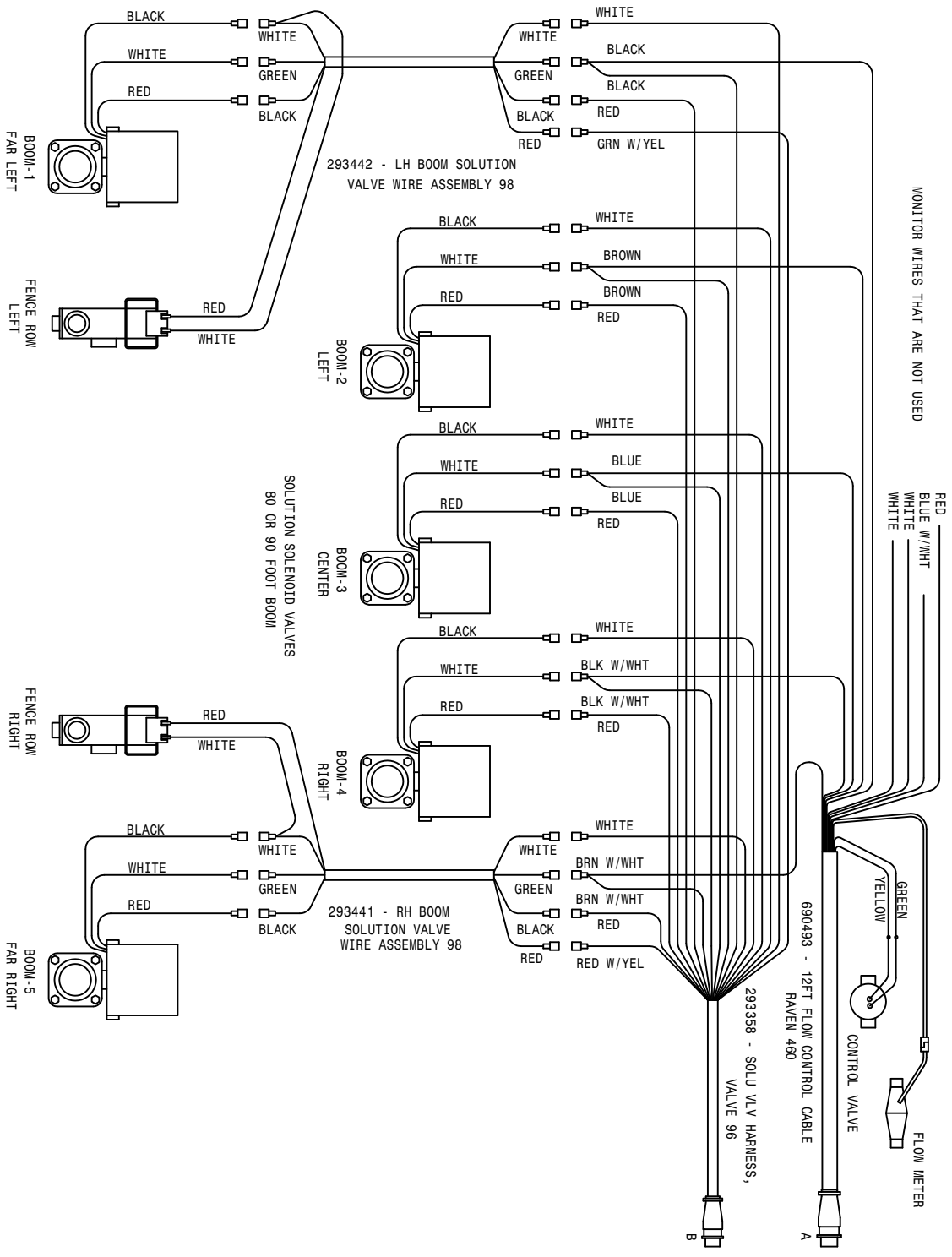
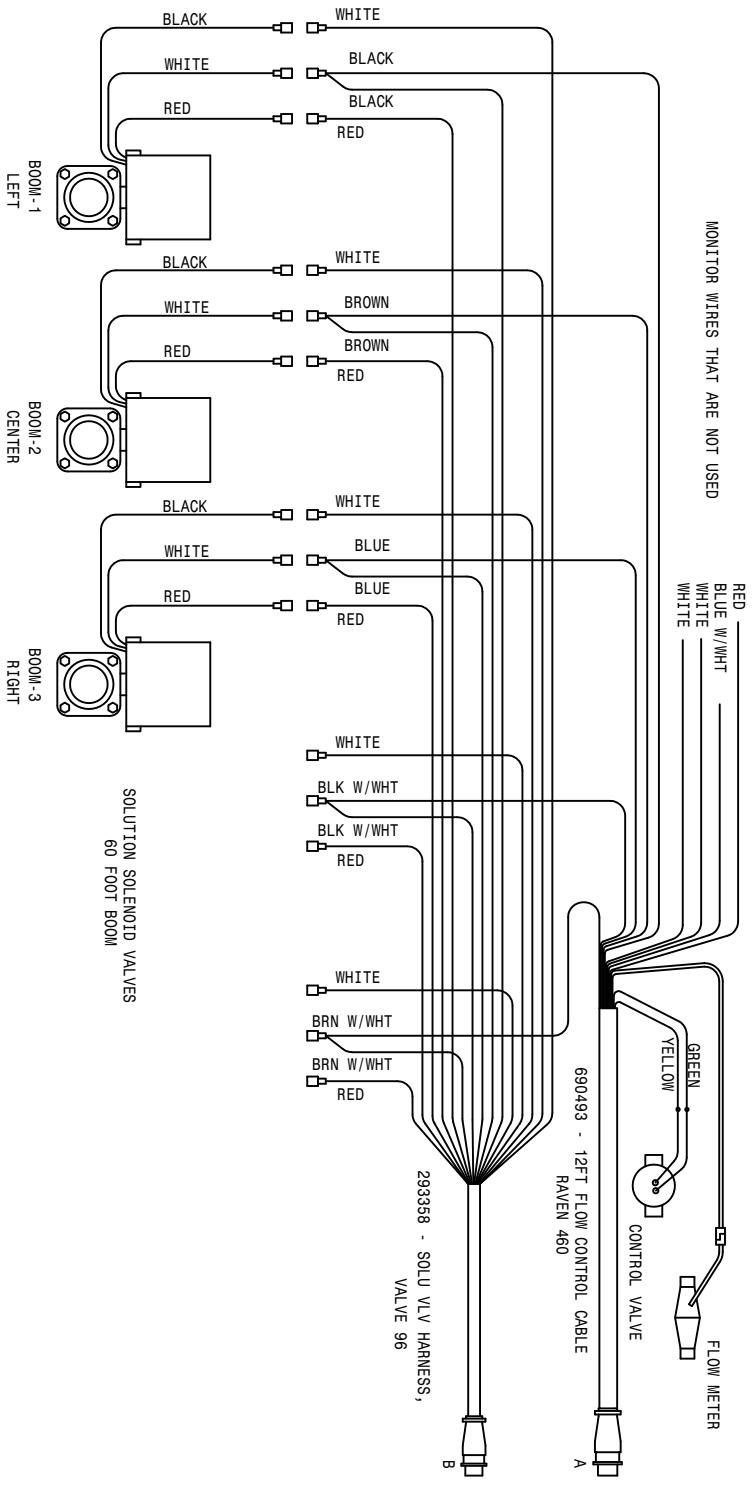

690492 - CONSOLE CONTROL CABLE RAVEN 460

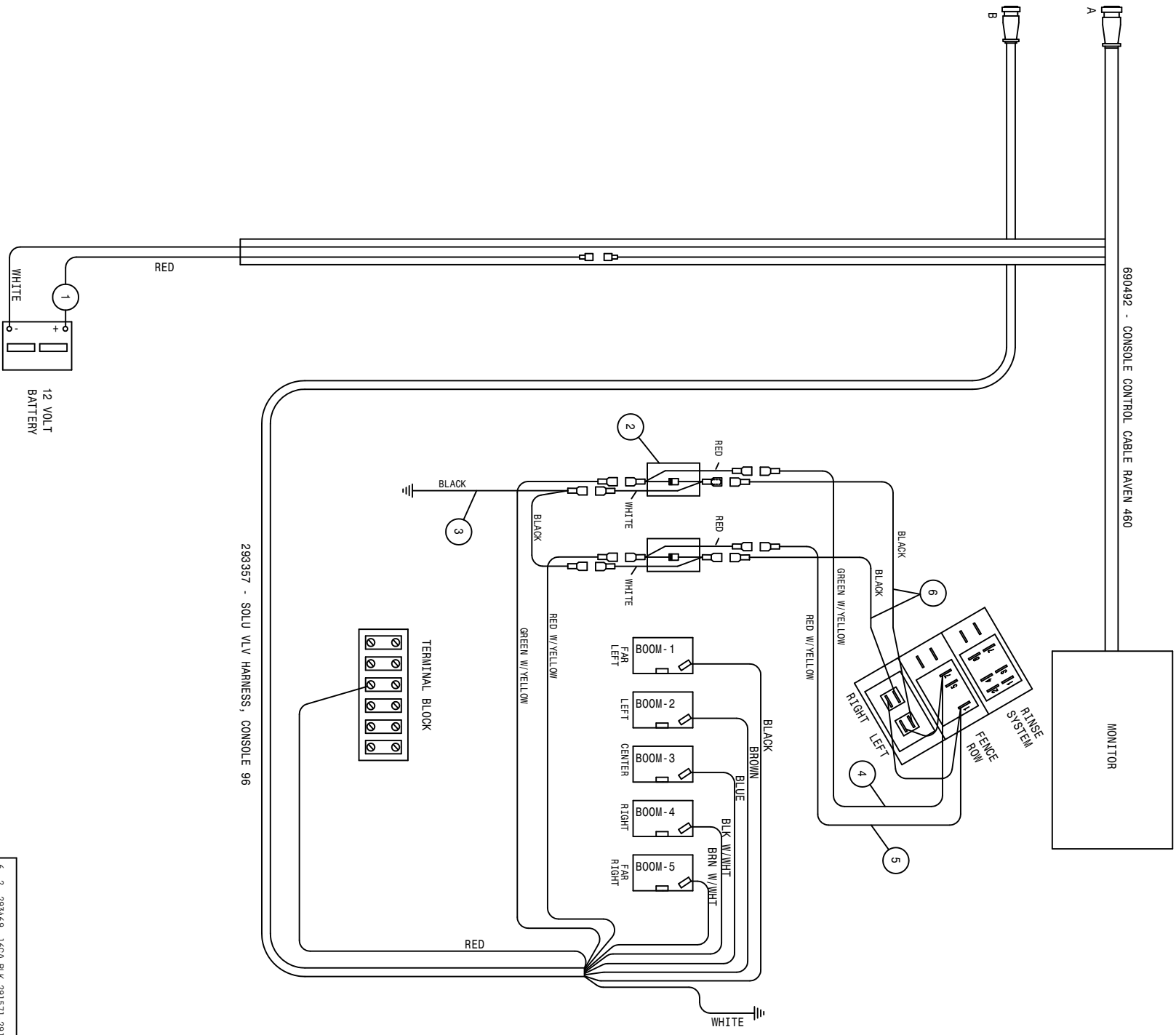

6	2	293469	16GA BLK-291571-291571-11
5	1	293470	RH FENCE ROW SWITCH WIRE
4	1	293471	LH FENCE ROW SWITCH WIRE
3	1	293472	FENCE ROW SWITCH GND WIRE
2	2	293317	DIODE SHUNT CABLE ASSY
1	1	293149	16GA RED-291559-291590-26

284 CUMM WIRING DIAGRAM 99

06-17-98 TUM

SHEET 5 OF 5
 ENGLISH DATE: 03-24-99
 498544

NOTICE

The following page contains decals for the model 2100.

These decals can be obtained from Hagie Mfg. Co. and should be used whenever your machine is repainted or when the decals become worn, weathered, or faded.

Special attention should be paid to decals involving personal safety. They have been attached for your protection.

KEEP THEM IN PLACE.

Contact: Hagie Manufacturing Co.
Box 273
Clarion, Iowa 50525

284 DECALS

QTY.	PART NO.	DESCRIPTION	LOCATION
1	650831	EMERGENCY STOP DECAL	ON LOWER LH FRONT CAB FOAM
1	650320	EMERGENCY EXIT DECAL	ON LOWER REAR OF EXIT WINDOW
1	650355	CONSOLE COVER PANEL DECAL	ON CONSOLE SHEET METAL
1	650340	PARK BRAKE DECAL	NEAR PARK SWITCH
1	650822	SOLUTION PUMP DECAL	ON FRONT CROSSMEMBER
1	650847	NO PASSENGER DECAL	REAR CORNER OF CAB
2	650848	SLIP OR FALL DECAL	2-ON EACH FUEL TANK
2	650849	ENGINE FUEL DECAL	NEAR EACH FUEL TANK NECK
2	650850	CHEMICAL DECAL	ON SOLUTION TANK LIDS
2	650851	SHIELDS DECAL	ON SIDE OF TOP ENGINE COVER
1	650852	READ MANUAL DECAL	ON LOWER LH FRONT CAB FOAM
1	650319	NOTICE-FRT LEG CYL OIL	ON TOP LH FRONT LEG
1	650326	HAGIE DECAL	ON FRONT MAINFRAME SHIELD
2	650954	DIESEL DECAL	NEAR EACH FUEL NECK
1	650981	COOLING SYSTEM DECAL	NEAR RADIATOR CAP
1	650982	ELECTRICAL DECAL	RIGHT HAND SIDE OF OIL TANK
4	650985	WHEEL BOLT TORQUE DECAL	ON EACH WHEEL RIM
1	650323	DECAL SET, HAGIE 284 STRIPE	ON EACH ENGINE HOOD
2	650324	DECAL STRIPE, 3 X 72	ON EACH TANK SHIELD
1	650329	SPRAY CONTROL/TRAC DECAL	ON INSTRUMENT PANEL
1	650334	SS SIGHT GAUGE DECAL	ON SIGHT GAUGE MOUNT
1	650336	FOLD BOOM WARNING DECAL	ON LOWER REAR OF EXIT WINDOW
1	650337	ELECTROCUTION HAZARD DECAL	ON LOWER REAR OF EXIT WINDOW
1	650339	HYDRAULIC OIL INJ. DECAL	ON LOWER REAR OF EXIT WINDOW
1	650347	NOTICE-R134A CHARGE DECAL	NEXT TO A/C COMPRESSOR
1	650348	NOTICE-DRAIN AIR TANK DECAL	ON AIR TANK

ABBREVIATIONS

A/C - AIR CONDITIONER	MT - MOUNT
ADPTR - ADAPTER	MTR - MOTOR
AGI - AGITATOR	P/N - PART NUMBER
ALT - ALTERNATOR	PLT - PLATE
ASSY - ASSEMBLY	QTY - QUANTITY
BRKT - BRACKET	RED - REDUCER
DET - DETAIL	REF - REFERENCE
DISPL - DISPLACEMENT	REST - RESTRICTOR
EL - ELBOW	REQ - REQUIRED
EXT - EXTENSION	SHFT - SHAFT
FLO - FLOW	SOL - SOLUTION
FNPT - FEMALE NATIONAL PIPE THREAD	STRG - STEERING
FOR - FEMALE O-RING	ST - STREET
FRT - FRONT	SWIV - SWIVEL
HYD - HYDRAULIC	UNC - UNIFIED NATIONAL COURSE
HYDRO - HYDROSTATIC	UNF - UNIFIED NATIONAL FINE
LG - LONG	V - VOLT
LWR - LOWER	W/ - WITH
MJIC - MALE J.I.C.	WHL - WHEEL
MOR - MALE O-RING	WLD - WELDMENT

INDEX

-A-

ABBREVIATIONS.....120
 ACCUMULATOR CYLINDER.....52,53
 ADJUSTMENT, TREAD.....80
 AGITATOR
 IMPELLER.....66,67
 SHAFT.....66,67
 SHIELD.....66,67
 SOLUTION.....66,67
 AIR CLEANER.....12
 BAND.....12
 FILTER.....12
 HOOD.....12
 HOSE.....12
 AIR CONDITIONER
 BLOWER MOUNT.....30
 COMPRESSOR.....10
 COMPRESSOR MOUNT.....10
 CONDENSOR.....10
 CONTROL.....30
 DRYER.....10
 FILTER.....30
 AIR SEAT.....28
 ANTENNA, RADIO.....30
 ARM,
 TANK SUPPORT.....47
 WIPER.....28

-B-

BALL VALVE.....64,65,68
 BAND,
 AIR CLEANER.....12
 FUEL TANK.....26
 TANK.....64,65
 BATTERY.....13
 BOX.....13
 CABLE.....13,38
 BELT.....5,10
 BINDING POST.....40
 BLADE,
 FAN.....5
 WIPER.....28
 BLOCK, TERMINAL.....35
 BOOM.....58,59,60,61,62,63
 CONTROL VALVE.....49
 GRADLE.....43
 PIVOT PIN.....51
 SPRING.....59,61
 BRACE,
 LADDER.....48
 LEG.....16,17

BRAKE SOLENOID.....38
 BREAKAWAY.....51
 BREAKER, CIRCUIT.....35
 BREATHER.....27

-C-

CAB.....28
 ROOF.....28
 CABLE,
 BATTERY.....13
 CONTROL.....35,36,37,38,42
 THROTTLE.....4
 4WD.....41
 CAP,
 FUEL.....26
 RADIATOR.....11
 STEERING.....32
 CATWALK.....48
 CHECK VALVE.....77
 CIRCUIT BREAKER.....35
 COMPRESSOR, A/C.....10
 CONDENSOR.....10
 MOUNT.....10
 CONSOLE.....35
 COVER.....34
 CONTROL HANDLE.....36
 COOLER, OIL.....11
 GRADLE.....64,65
 BOOM.....43
 CROP GUIDE.....14,15,18
 CROPSHIELD.....95
 CYLINDER,
 ACCUMULATOR.....52,53
 FOLD.....56
 FRONT LEG.....26
 LEVEL.....55
 LIFT.....54
 STEERING.....21
 TREAD ADJUSTMENT.....81,82,83

-D-

DECALS.....118,119
 DIAGRAM, WIRING.....108
 DIFFUSER, LINE SUMP.....27
 DIMMER SWITCH.....28
 DIPSTICK.....27

DOOR.....29
HANDLE.....29
DRINK HOLDER.....35
DRIVE ASSEMBLY.....4
DRYER, A/C.....10

-E-

ELECTRIC SOLENOID VALVE..70,71,72
ENGINE.....4,5
HOOD.....44
MOUNTS.....4,5
EXHAUST PIPE.....12

-F-

FAN
BLADE.....5
SPACER.....5
FILTER,
AIR CLEANER.....12
AIR CONDITIONER.....30
FUEL.....4
HI-PRESS.....9
INLINE HYDRAULIC.....49
MICHIGAN.....27
MINDER.....33
OIL.....5,27
FLASHER LIGHT.....43
FLASHER SWITCH.....32
FLOORMAT.....31
FLOW CONTROL
VALVE.....70,71
VARIABLE.....42
FLOW DIVIDER.....7
FLOW METER.....70,71
FLUSHING VALVE.....8
FOAM.....11,31
FOAMER TANK.....86
FOLD CYLINDER.....51,56,57
FUEL
CAP.....26
GAUGE.....33
SELECTOR VALVE.....26
SENDER.....26
TANK.....26
FUSE.....34
HOLDER.....34

-G-

GAUGE,
FUEL.....33
OIL PRESSURE.....33
PRESSURE.....70,71
SIGHT.....65,71
TEMPERATURE.....33
GAS SPRING.....29

GLASS.....28,29
GLAND PACKING.....66,67
GRAB HANDLE.....28
GROUND STRAP.....4,13,28
GUARD, SPRING.....100,101
GUIDE, CROP.....18

-H-

HANDLE,
CONTROL.....36
DOOR.....29
GRAB.....28
HANDRAIL.....44
HEADLIGHT.....28
HEADLINER.....30
HEATER SOLENOID.....5
HEAT SHIELD.....11
HI-PRESS
FILTER.....9
MANIFOLD.....91
HOLDER, DRINK.....35
HOOD,
AIR CLEANER.....12
ENGINE.....44
HOOK, RUBBER.....44
HOSE, AIR CLEANER.....12
HOSING, SOLUTION.....100,101
HOUR METER.....33
HUB, TORQUE.....14,15,16,17
HYDRAULIC
SCHEMATIC.....98
TANK.....27
TUBE.....14,15,16,17,51,59
HYPRO D-230 PUMP.....90

-I-

IMPELLER.....66,67
INDICATOR, MPH-RPM.....33
INLINE HYDRAULIC FILTER.....49
INTERIOR LIGHT.....30

-K-

KICK PANEL.....28
KNOB.....34,35

-L-

LADDER.....48
BRACE.....48
LEG,
BRACE.....16,17
CYLINDER.....22
FRONT.....14,15
REAR.....16,17
LEVEL CYLINDER.....51,55

LEVER, HYDROSTATIC.....36
 THROTTLE.....37
 LID.....64, 65, 68
 LIFTARM.....50
 MOUNT.....50
 SOLENOID, LOCK.....58
 LIFT CYLINDER.....50, 54
 LIGHT,
 HEAD.....28
 INTERIOR.....30
 SWITCH.....34
 TURN SIGNAL.....43
 LINE SUMP DIFFUSER.....27

-M-

MANIFOLD, HI-PRESS.....91
 METER, HOUR.....33
 MIRROR.....28
 MOTOR
 STEERING.....32
 WHEEL.....14, 15, 16, 17
 WIPER.....28
 MOUNT,
 A/C BLOWER.....30
 CONDENSOR.....10
 ENGINE.....4, 5
 FLOW DIVIDER.....7
 LIFTARM.....50
 MONITOR.....35
 RADIATOR.....11
 RUBBER.....4, 5, 28
 SOLUTION VFC.....42
 TANK.....46
 MUFFLER.....12
 MULLION.....44

-N-

NOZZLE, RINSE.....79
 NYLON SLEEVE.....14, 15

-O-

OIL
 COOLER.....11
 FILTER.....5
 PRESSURE GAUGE.....33
 SENDER.....4
 TANK.....27

-P-

PANEL, KICK.....28
 PARK BRAKE SWITCH.....40

PIVOT PIN, BOOM.....51
 PLATFORM, SERVICE.....48
 POSITRACTION VALVE.....6
 POWER POINT.....40
 PRESSURE GAUGE.....70, 71
 PRESSURE WASHER.....96
 PUMP,
 HYPRO D-230.....90
 SOLUTION.....76, 77
 SUNDSTRAND.....6

-R-

RADIATOR.....11
 CAP.....11
 HOSE.....5
 MOUNT.....11
 SCREEN.....11
 SHROUD.....11
 RADIO.....30
 RECOVERY.....11
 RELAY.....36
 RELIEF VALVE.....7
 RIM.....18
 RINSE,
 NOZZLE.....79
 TANK.....78
 ROOF, CAB.....28
 RUBBER,
 HOOK.....45
 MOUNT.....4, 5, 28
 WASHER.....7, 41

-S-

SCHEMATIC, HYDRAULIC.....102
 SCREEN.....45
 RADIATOR.....11
 SEAL BOOT.....14, 15, 16, 17
 SEAT.....39
 SELECTOR VALVE, FUEL.....26
 SENDER,
 FUEL.....26
 OIL.....4
 TEMPERATURE.....5
 SERVICE PLATFORM.....48
 SHAFT, AGITATOR.....66, 67
 SHEETMETAL.....44, 45
 SHIELD,
 AGITATOR.....66, 67
 HEAT.....11
 SIDE.....45
 TANK.....46, 47
 WHEEL MOTOR.....14, 15, 16, 17
 SHROUD, RADIATOR.....11

SIGHT GAUGE.....	64, 65, 69
SMV SIGN.....	45
SOLENOID, HEATER.....	5
SOLUTION	
AGITATOR.....	66, 67
HOSING.....	100, 101
PUMP.....	76, 77
TANK.....	65, 68
SPACER, FAN.....	5
SPEAKER.....	30
SPRING.....	37
BOOM.....	59, 61
GUARD.....	100, 101
STALK GUIDE.....	18
STEERING	
ARM.....	14, 15
CAB.....	32
CYLINDER.....	21
MOTOR.....	32
PIVOT.....	24, 25
POST.....	32
WHEEL.....	32
STRAINER.....	65
STRAP, GROUND.....	4, 13, 28
SUNDSTRAND PUMP.....	6
SUPPORT ARM.....	47
SWITCH	
DIMMER.....	28
FLASHER.....	32
LIGHT.....	34
PARK BRAKE.....	40
TOGGLE.....	34

-T-

TAILLIGHT.....	45
TANK,	
BAND.....	64, 65
FUEL.....	26
HYDRAULIC OIL.....	27
LID.....	64, 65, 68
MOUNTS.....	46, 47
RECOVERY.....	11
RINSE.....	74
SHIELD.....	46, 47
SOLUTION.....	64, 65, 68
TEMPERATURE	
GAUGE.....	33
SENDER.....	5
TERMINAL BLOCK.....	35
THROTTLE	
CABLE.....	4
LEVER.....	37
TIE ANGLE.....	47
TIE ROD.....	24, 25
TIRE.....	18

TOGGLE SWITCH.....	34
TORQUE HUB.....	14, 15, 16, 17
TRANSOM.....	51
TREAD ADJUSTMENT.....	80
CYLINDER.....	81, 82, 83
TUBE,	
HYDRAULIC.....	50, 59
4WD.....	41
TURN SIGNAL LIGHT.....	28

-V-

VALVE,	
BALL.....	64, 65, 68
BOOM CONTROL.....	70, 71
CHECK.....	77
ELECTRIC SOLUTION.....	64, 65, 68
FLOW CONTROL.....	70, 71, 92
FLUSHING.....	8
POSITRACTION.....	6
RELIEF.....	7
SOLUTION SOLENOID.....	70, 71, 72
4WD.....	41
VARIABLE FLOW CONTROL.....	42
VOLTMEETER.....	33

-W-

WASHER, PRESSURE.....	96
WEATHER STRIP, WINDOW.....	28, 29
WHEEL MOTOR.....	14, 15, 16, 17
SHIELD.....	16, 17
WHEEL, STEERING.....	32
WINDSHIELD WASHER.....	94
WIPER	
ARM.....	28
BLADE.....	28
MOTOR.....	28
WIRING DIAGRAM.....	108

