

**PARTS MANUAL**  
**FOR**  
**HAGIE MODEL 2100 HI-TRACTOR**

**HAGIE MANUFACTURING COMPANY**

BOX 273 CLARION, IOWA 50525 (515) 532-2861

COVERS MACHINE SERIAL NUMBERS: U1400110001 thru U1400110100

01-01 493225  
02-08

## SPRAYER IDENTIFICATION

Each Hagie sprayer is identified by means of a frame serial number. This serial number denotes the model, the year in which it was built, and the number of the sprayer. As for further identification, the engine has a serial number and the planetary hubs have identification plates that describe the type of mount and gear ratio. To insure prompt, efficient service when ordering parts or requesting service repairs from Hagie Manufacturing Company, record the serial and identification numbers in the space provided below.

NOTE: Reference to left hand and right hand used throughout this manual refers to the position when seated in the operator's seat facing forward.

SPRAYER SERIAL NUMBER

---

ENGINE SERIAL NUMBER

---

PLANETARY HUB IDENTIFICATION NUMBERS

---

TABLE OF CONTENTS

ENGINE ASSEMBLY . . . . . 4-7

AIR TANK ASSEMBLY . . . . . 8-9

LOOP FLUSHING . . . . . 10-11

WHEEL MOTOR VALVES. . . . . 12

VFC AND FLOW DIVIDER. . . . . 13-18

RADIATOR AND OIL COOLER ASSEMBLY. . . . . 19

OIL TANK ASSEMBLY . . . . . 20

TIRE ASSEMBLY . . . . . 21

LEG ASSEMBLY. . . . . 22-29

STEERING CYLINDER . . . . . 30-31

MUFFLER AND AIR CLEANER . . . . . 32-33

CAB ASSEMBLY. . . . . 34-38

INSTRUMENT PANEL ASSEMBLY . . . . . 39

CONSOLE ASSEMBLY. . . . . 40-43

SWITCH PANEL ASSEMBLY . . . . . 44

FOAM AIR REGULATOR. . . . . 45

FUSE BOX AND SEAT . . . . . 46-47

SHEET METAL . . . . . 48-49

RECOVERY TANK AND WINDSHIELD WASHER . . . . . 50-51

LADDER. . . . . 52-53

FUEL TANK . . . . . 54

SERVICE PLATFORM. . . . . 55

BOOM GRADLE . . . . . 56-57

BATTERY . . . . . 58

SOLUTION TANK . . . . . 59-63

SOLUTION PUMP AND SOLENOIDS . . . . . 64-69

QUICK FILL AND FENCE ROW. . . . . 70-73

SOLUTION HOISING . . . . . 74-78

SOLUTION PUMP . . . . . 79

TRANSOM, BOOM, AND LIFT COMPONENTS. . . . . 80-94

BOOM SECTION LIGHTS . . . . . 95

RINSE . . . . . 96-97

FOAMER. . . . . 98-99

TREAD ADJUSTMENT OPTION. . . . . 100-103

PRESSURE WASHER AND CHEMICAL INDUCTOR OPTION . . . . . 104-106

REAR WHEEL NOZZLE AND RADAR OPTION. . . . . 107-108

INJECTION PLATFORM AND FOAMER DIVERT VALVE OPTION . . . . . 109-110

DECALS. . . . . 112-113

HYDRAULIC SCHEMATIC . . . . . 114-119

ELECTRICAL SCHEMATIC. . . . . 120-129

ABBREVIATIONS . . . . . 130

INDEX . . . . . 131

PARTS ORDER FORM. . . . . 135

ENGINE ASSEMBLY

DET.	QTY	PART NO.	DESCRIPTION
1	2	311053	RUBBER MOUNT SET,SSB26-1000-1
2	1	314307	RADIATOR HOSE 21194
3	2	193012	QUICKEDGE TRIM .135 TO .250
4	3	291197	CIRCUIT BREAKER,30AMP,INLINEMT
5	1	291531	GROUND CABLE, 15"
6	2	291683	BUSS BAR,2 GANG CIRCUIT BREAKR
7	1	314308	RADIATOR HOSE, GOODYEAR 60880
8	1	314836	TEMP SENDR 280D 1/2NPT FOR GA
9	1	316199	22IN FAN SPACER CUMM 92
10	1	316250	RH FRT ENG MT WLD, CUMM 94
11	1	316313	LH FRT ENG MT WLD, 284 CUMM 98
12	1	316327	FAN, 24" 6 BLADE 28.5DEG CCW
13	1	316336	RH HYD TUBE MT, 2100 98
14	1	316339	BREAKER MTG PLT, 2100 98
15	1	316340	BREAKER COVER, 2100 98
16	4	470175	10-32 HEX FLANGE LOCK NUT
17	2	470216	10-32 X 3/4 FLANGE HEX BOLT
18	1	470274	TUBE CLAMP BODY, .750-.750
19	1	470276	CLAMP COVER PLATE,SNGL, 2.55LG
20	1	470278	CLAMP WELD PLATE, SNGL, 2.75LG
21	1	473770	5MM-.80 HEX NUT
22	6	473775	12MM-1.75 X 30MM HEX BOLT
23	1	473779	10MM-1.50 HEX NUT
24	2	473783	12MM-1.75 X 25MM HEX BOLT
25	8	473784	12MM LOCK WASHER
26	4	473804	8MM LOCK WASHER
27	4	473822	8MM-1.25 X 70MM HEX BOLT
28	1	618573	5/8 HOSE BARB-90-1/2MNPT
29	1	900086	5/16UNC X 2 1/4 HEX BOLT
30	6	903812	6-32 X 1/2 SLT RD HD MACH SCR
31	12	910022	6-32 HEX NUT
32	12	910027	10-32 HEX NUT
33	1	316310	CUMM ENG,6B5.9A 174@2500 CMPSR
34	2	520067	HOSE CLAMP NO 28 STAINLESS
35	1	316207	LUBE FILTER CUMMINS DIESEL 92
36	1	316206	POLY V BELT CUMMINS DIESEL 92
37	1	520055	HOSE CLAMP NO 12 STAINLESS
38	2	520099	HOSE CLAMP NO 40 STAINLESS
39	2	900271	1/2UNC X 3 1/4 HEX BOLT
40	2	914008	1/2UNC HEX STOVER NUT
41	2	920004	1/2 SAE FLAT WASHER
42	1	520126	CUSH HOSE CLAMP 2IN X 5/8W
43	1	920501	5/16 LOCK WASHER
44	1	316346	105 AMP ALT,DELCO W/PULLEY
45	1	316216	STARTER FOR CUMM 6 CYL 316185

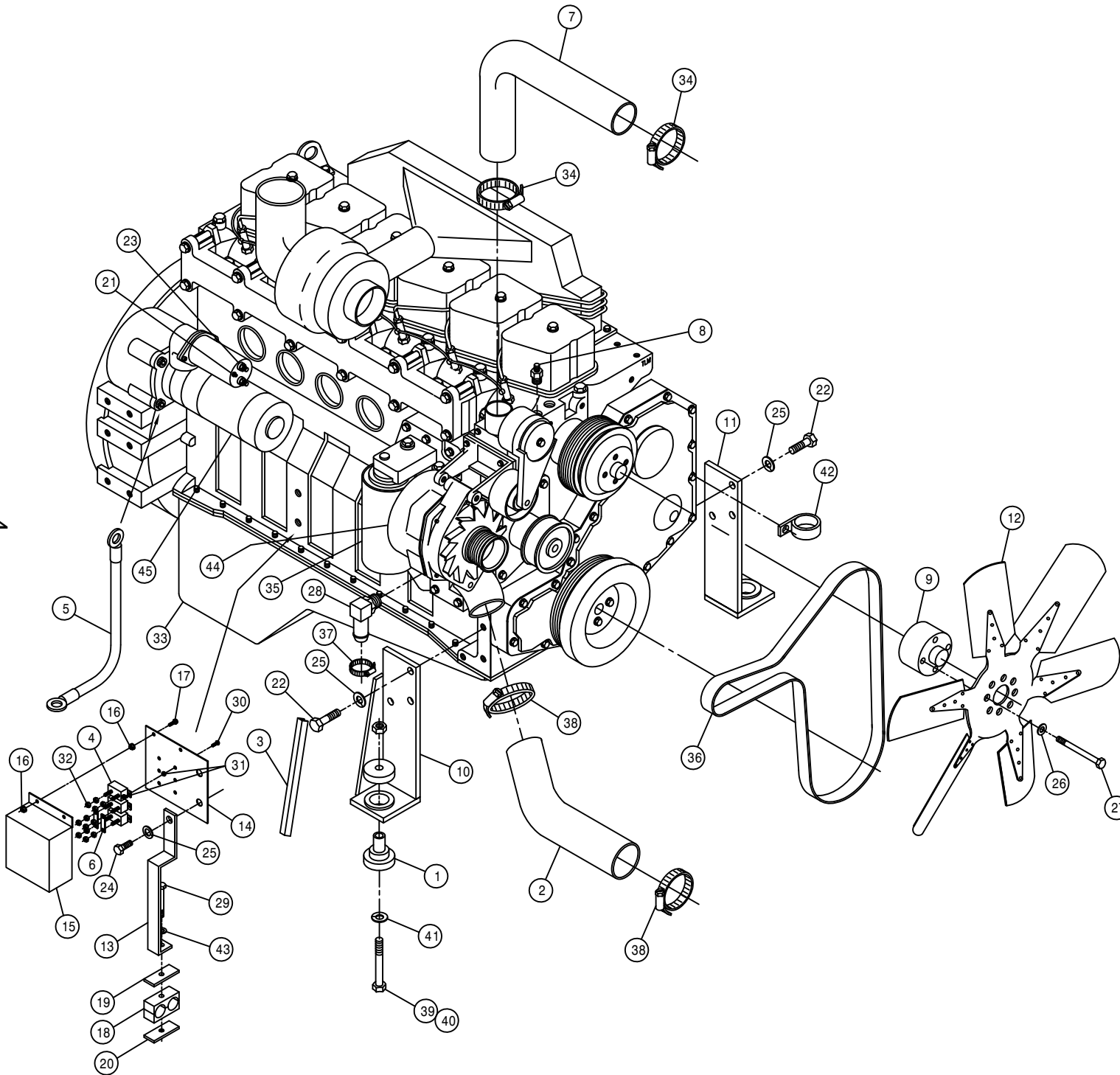

4

ENGINE ASSEMBLY

DET. QTY PART NO. DESCRIPTION

1	1	291674	OIL PRESS SENDER,125PSI,1/8NPT
2	1	316252	RH REAR ENG MT WLD, CUMM 94
3	1	316253	LH REAR ENG MT WLD, CUMM 94
4	1	316303	THROTTLE CABLE MT,6CYL CUMM 97
5	1	316304	THROTTLE LEVER EXT,6CYL CUMM97
6	1	316310	CUMM ENG,6B5.9A 174@2500 CMPSR
7	1	316322	AIR REGULATOR BRKT 98
8	1	316337	LH HYD TUBE MT, 2100 98
9	1	316338	REAR HYD TUBE MT, 2100 98
10	1	470274	TUBE CLAMP BODY, .750-.750
11	1	470275	TUBE CLAMP BODY,1.000-1.000
12	2	470278	CLAMP WELD PLATE, SNGL, 2.75LG
13	8	473775	12MM-1.75 X 30MM HEX BOLT
14	10	473784	12MM LOCK WASHER
15	11	473792	10MM-1.50 X 30MM HEX BOLT
16	12	473798	10MM LOCK WASHER
17	1	473818	10MM-1.50 X 40MM HEX BOLT
18	2	473826	6MM-1.00 X 16MM HEX BOLT
19	2	473828	12MM-1.50 X 20MM HEX BOLT
20	1	800502	PUMP DRIVE,DIRECT SAE#3/C 23T
21	1	800503	DRIVE DISK ASSY,11.5" 23T SPL
22	2	900072	5/16UNC X 3" HEX BOLT
23	1	900086	5/16UNC X 2 1/4 HEX BOLT
24	8	900128	3/8UNC X 3/4 HEX BOLT
25	2	914002	5/16UNC HEX STOVER NUT
26	2	920500	1/4 LOCK WASHER
27	8	920502	3/8 LOCK WASHER
28	2	920004	1/2 SAE FLAT WASHER
29	1	785079	CTRL CABLE 10-32 4IN X 140 IN
30	1	473921	BALL JOINT NO 10-32 THD
31	2	910027	10-32 HEX NUT
32	1	903893	10-32 X 1" SLT RD HD MACH SCR
33	1	914027	10-32 HEX STOVER NUT
34	2	920510	#10 LOCK WASHER
35	2	900271	1/2UNC X 3 1/4 HEX BOLT
36	2	311054	RUBBER MOUNT SET, CB-2202-4
37	2	311055	REBOUND WASHER FOR 311054
38	4	520120	HOSE CLAMP NO 4 STAINLESS
39	1	316281	FUEL STRAINER, IN-LINE, DIESEL
40	1	601347	HOSE, 3/8 X 10 FUEL LINE
41	1	520055	HOSE CLAMP NO 12 STAINLESS
42	1	316208	FUEL FILTER, PRIMARY CUMM 92
43	1	316209	FUEL FILTER, SECONDARY CUMM92
44	1	601414	HOSE, 1/4 X 31 AIR
45	2	193012	QUICKEDGE TRIM .135 TO .250
46	1	711026	1/8MNPT-90-1/4OD NYL TUBE FTG
47	1	611147	3/4MJIC-1/2MNPT ADPTR
48	1	611293	04P919-04FJX-04FJX-20 H/A
49	2	618447	7/16MJIC-90-1/8MNPT LBO
50	2	914008	1/2UNC HEX STOVER NUT
51	1	900069	5/16UNC X 2" HEX BOLT
52	2	920501	5/16 LOCK WASHER
53	1	500900	BLK PIPE ST EL 90DEG .125NPT
54	1	473804	8MM LOCK WASHER
55	1	473827	8MM-1.25 X 20MM HEX BOLT
56	1	601537	HOSE, 3/4 X 24 CLEAR VINYL

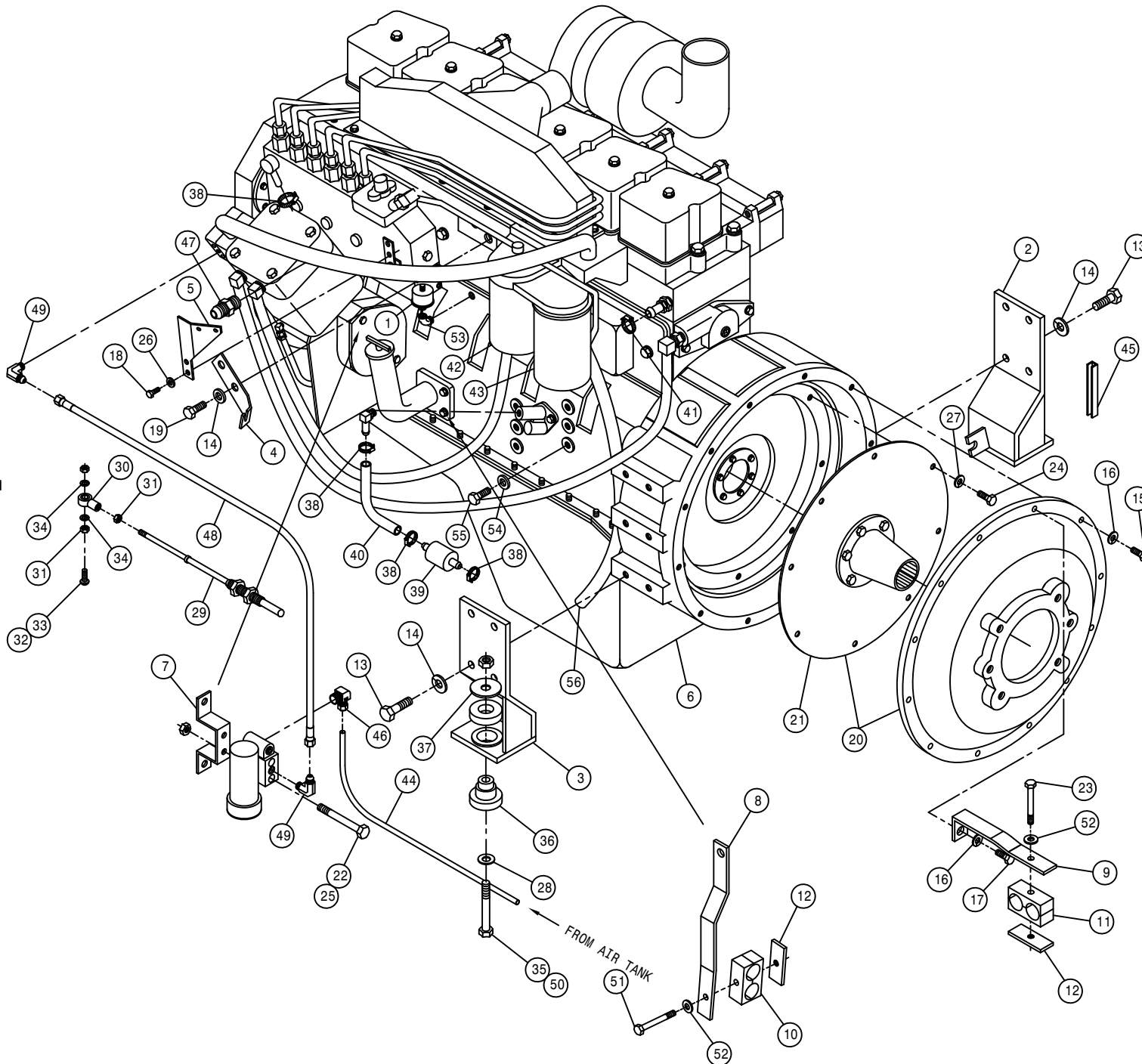

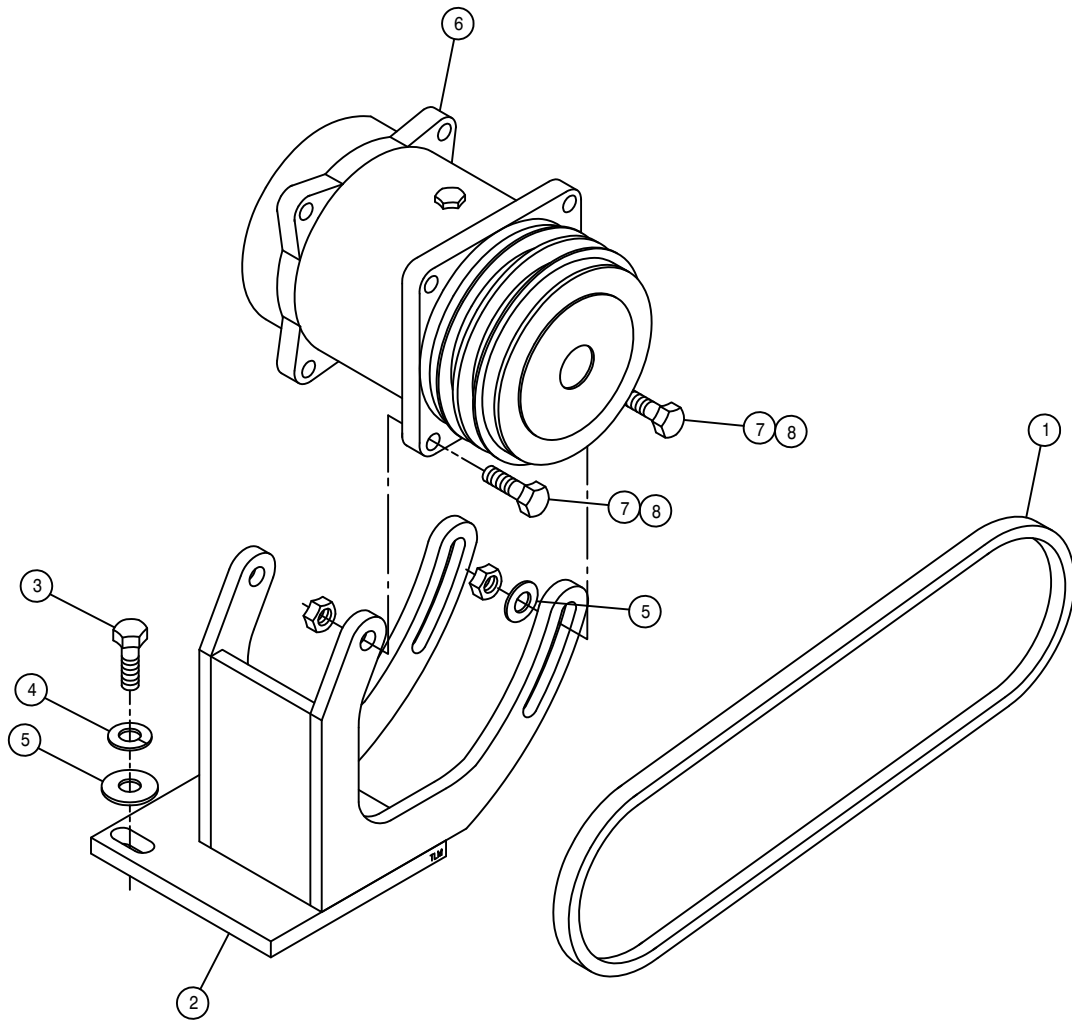

A/C COMPRESSOR PUMP ASSEMBLY

DET. QTY PART NO. DESCRIPTION

1	1	147050	9455XL BELT, GATES	
2	1	316314	A/C COMPRESR MT WLD, 284	98
3	3	473792	10MM-1.50 X 30MM HEX BOLT	
4	3	473798	10MM LOCK WASHER	
5	5	483043	3/8 REGULAR FLAT WASHER	
6	1	657403	A/C COMPRESR, 180D PORTS TM15/12	
7	4	900131	3/8UNC X 1 1/2 HEX BOLT	
8	4	914004	3/8UNC HEX STOVER NUT	

SUNDSTRAND PUMP ASSEMBLY

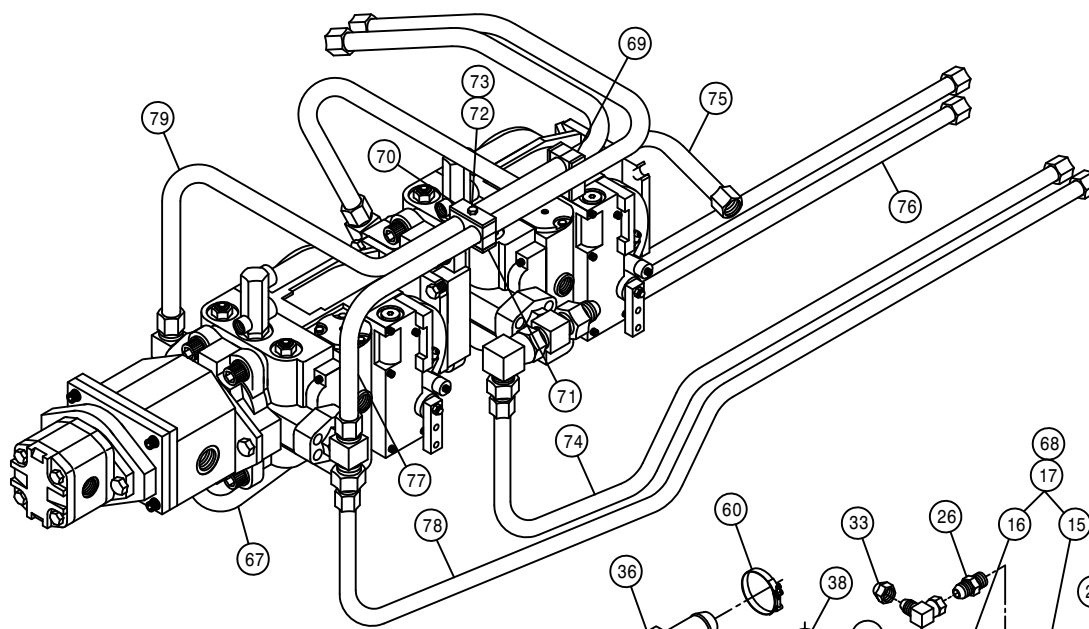

DET.	QTY	PART NO.	DESCRIPTION
68	1	606950	O-RING, SUND 9004100-0480
69	2	470275	TUBE CLAMP BODY, 1.000-1.000
70	2	470276	CLAMP COVER PLATE, SNGL, 2.55LG
71	2	470278	CLAMP WELD PLATE, SNGL, 2.75LG
72	2	900086	5/16UNC X 2 1/4 HEX BOLT
73	2	920501	5/16 LOCK WASHER
74	1	615717	RH FRT PUMP LWR TUBEASSY210098
75	1	615718	LH FRT PUMP UPR TUBEASSY210098
76	1	615719	LH FRT PUMP LWR TUBEASSY210098
77	1	615720	RH REAR PUMP UPR TUBE ASSY 98
78	1	615721	RH REAR PUMP LWR TUBE ASSY 98
79	1	615722	LH REAR PUMP UPR TUBE ASSY 98

DET.	QTY	PART NO.	DESCRIPTION
1	1	311054	RUBBER MOUNT SET, CB-2202-4
2	1	311055	REBOUND WASHER FOR 311054
3	1	316160	PUMP CONT LEVER EXT 280 CUMM
4	1	316335	HYDST PUMP CTRL ROD, 2100 98
5	1	316341	AUX PUMP SUPP MT WLD, 2100 98
6	16	470188	7/16-14 X 1 1/2 SKTHD CAP SCR
7	16	470189	7/16 HC LOCK WASH FOR 618598
8	2	473998	BALL JOINT, 1/4-28 1/4BORE
9	1	505098	SIDE OUTLET EL 90DEG 1.00NPT
10	1	505101	BLK PIPE TEE 1.00NPT
11	2	505105	1MMPT HEX PIPE NIPPLE STL
12	3	505200	BLK PIPE ST EL 90DEG 1.00NPT
13	5	520137	1.19/1.37 T-BOLT HOSE CLAMP
14	1	601383	HOSE, 3/4 X 8 1FBR-1SPI
15	1	606944	SUND 75CC PUMP, C/C-MT
16	1	606947	SUND 75CC PUMP, C/B-MT
17	1	606943	TANDEM PUMP, 606944 & 606947
18	1	606929	SUND GEAR PUMP .60CI, SPLINED
19	1	606932	SUND GEAR PUMP, 1.60CI, SPLINED
20	1	606941	TANDEM PUMP, 606929 & 606932
21	1	611126	7/8MJIC-7/8MOR ADPTR
22	2	614740	RESTRICTOR FTG ASSY, .050
23	1	618075	3/4 HOSE BARB-1 1/16MOR
24	1	618090	1 5/16MOR-1FNPT ADPTR
25	2	618118	3/4 HOSE BARB-90-1 1/16MOR
26	2	618126	9/16MJIC-9/16MOR ADPTR
27	2	618291	9/16FJX-1/4FNPT ADPTR
28	4	618327	3/4MJIC-7/8MOR ADPTR
29	1	618328	7/8FJIC CAP NUT
30	1	618333	7/8FJIC SW RUN TEE-7/8MJIC
31	2	618486	9/16FJIC SW RUN TEE-9/16MJIC
32	1	618514	9/16FJ SW BRANCH TEE-9/16MJ
33	4	618531	9/16FJIC CAP NUT
34	1	618535	7/8MJIC-90-1 1/16MOR LBO
35	5	618541	1 5/16FJIC-1 1/16MJIC ADPTR
36	2	618564	1IN HOSE BARB-90-1 5/16MOR
37	4	618598	1" 4-BOLT FLG X 1 5/16 FOR
38	4	618599	1 5/16MOR BRANCH TEE-1 5/16MJ
39	4	618629	9/16MOR BRANCH TEE-9/16MJIC
40	1	618640	1 5/16MJ-90-1 5/16FJ SWIV LBO
41	2	618643	3/4FJ SW BRANCH TEE-3/4MJ
42	1	714331	1 NPT X 3/4 HOSE BARB
43	1	714560	1NPT X 1 HOSE BARB
44	1	716000	3/4 HOSE BARB-90-1MMPT
45	4	870219	BUNA ORING 1 5/16 X 1 9/16
46	1	900003	1/4UNC X 1" HEX BOLT
47	1	900004	1/4UNC X 1 1/4 HEX BOLT
48	1	900005	1/4UNC X 1 1/2 HEX BOLT
49	1	900263	1/2UNC X 1" HEX BOLT
50	4	900265	1/2UNC X 1 1/2 HEX BOLT
51	1	903893	10-32 X 1" SLT RD HD MACH SCR
52	2	910001	1/4UNF HEX NUT
53	2	910027	10-32 HEX NUT
54	1	473921	BALL JOINT NO 10-32 THD
55	1	618618	9/16MJIC-90-9/16FJIC SWIV LBO
56	3	914000	1/4UNC HEX STOVER NUT
57	5	920004	1/2 SAE FLAT WASHER
58	1	920504	1/2 LOCK WASHER
59	4	920500	1/4 LOCK WASHER
60	3	520138	1.38/1.56 T-BOLT HOSE CLAMP
61	3	920510	#10 LOCK WASHER
62	1	914027	10-32 HEX STOVER NUT
63	1	606870	O-RING FOR 606865 SUND B-MT
64	1	606924	O-RING FOR SUND A-MT
65	1	900271	1/2UNC X 3 1/4 HEX BOLT
66	1	914008	1/2UNC HEX STOVER NUT
67	1	615723	LH REAR PUMP LWR TUBE ASSY 98

7

225007

AIR WET TANK ASSEMBLY

DET. QTY PART NO. DESCRIPTION

1	1	470266	DRAIN VALVE KIT, 1/4NPT	
2	2	520086	HOSE CLAMP NO 88 STAINLESS	
3	1	611145	3/4MJIC-90-1/2MNPT LBO	
4	1	610305	3/4MJIC-90-3/4MNPT LBO	
5	1	701115	WET TANK WLD	98
6	1	701118	WET TANK MT BRKT WLD	
7	1	614743	06C1T-08FJX-08FJX-14	H/A
8	1	611294	08P919-08FJX-08FJX-12.5	H/A
9	2	900129	3/8UNC X 1" HEX BOLT	
10	2	914004	3/8UNC HEX STOVER NUT	
11	1	711050	3/4"FNPT CHECK VALVE S.S.	
12	1	618711	3/4MNPT-90-1/2MNPT REDU LBO	

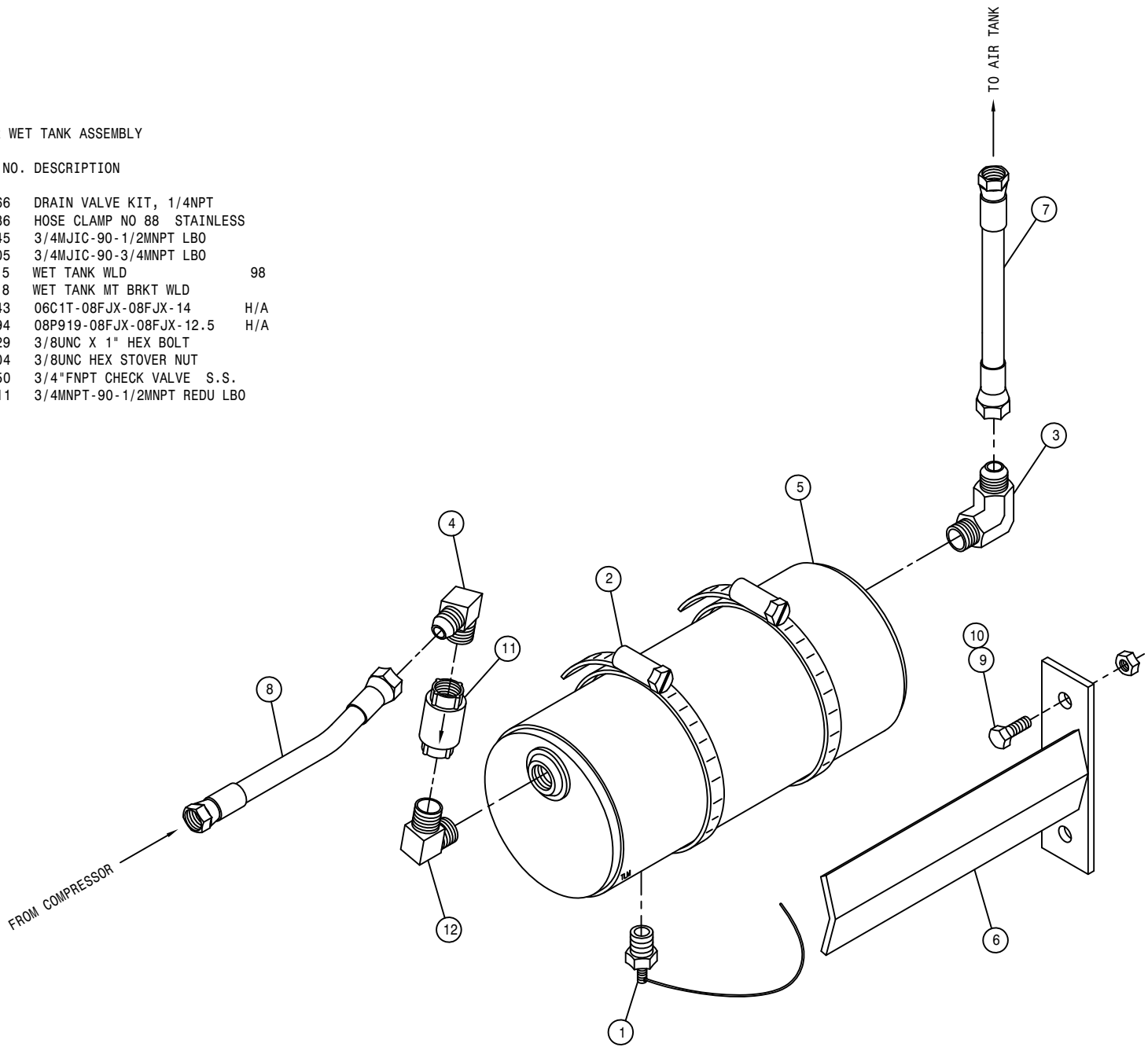



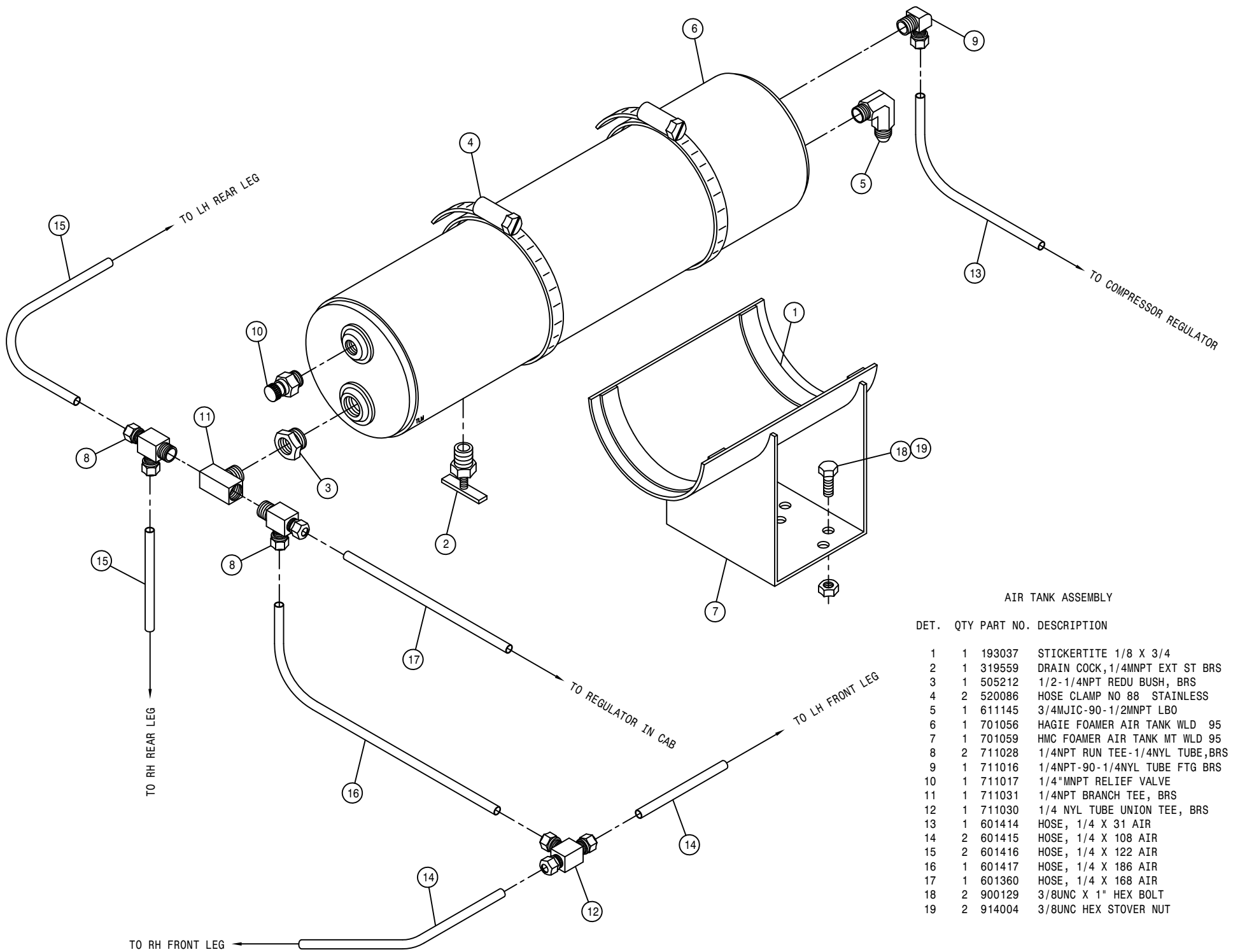

AIR TANK ASSEMBLY

DET.	QTY	PART NO.	DESCRIPTION
1	1	193037	STICKERTITE 1/8 X 3/4
2	1	319559	DRAIN COCK, 1/4MNPT EXT ST BRS
3	1	505212	1/2-1/4NPT REDU BUSH, BRS
4	2	520086	HOSE CLAMP NO 88 STAINLESS
5	1	611145	3/4MJIC-90-1/2MNPT LBO
6	1	701056	HAGIE FOAMER AIR TANK WLD 95
7	1	701059	HMC FOAMER AIR TANK MT WLD 95
8	2	711028	1/4NPT RUN TEE-1/4NYL TUBE, BRS
9	1	711016	1/4NPT-90-1/4NYL TUBE FTG BRS
10	1	711017	1/4" MNPT RELIEF VALVE
11	1	711031	1/4NPT BRANCH TEE, BRS
12	1	711030	1/4 NYL TUBE UNION TEE, BRS
13	1	601414	HOSE, 1/4 X 31 AIR
14	2	601415	HOSE, 1/4 X 108 AIR
15	2	601416	HOSE, 1/4 X 122 AIR
16	1	601417	HOSE, 1/4 X 186 AIR
17	1	601360	HOSE, 1/4 X 168 AIR
18	2	900129	3/8UNC X 1" HEX BOLT
19	2	914004	3/8UNC HEX STOVER NUT

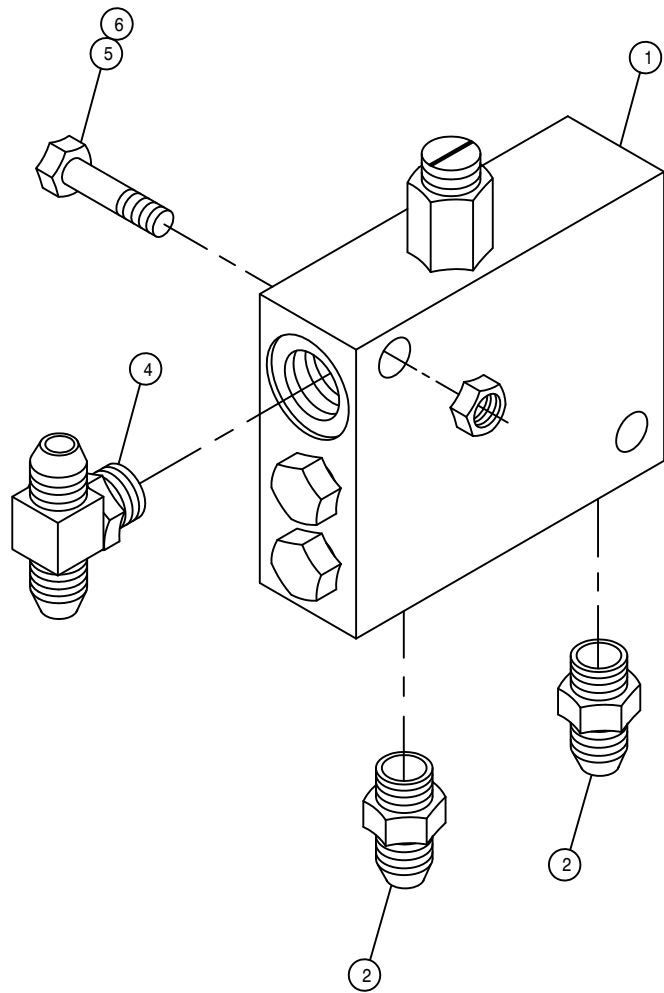
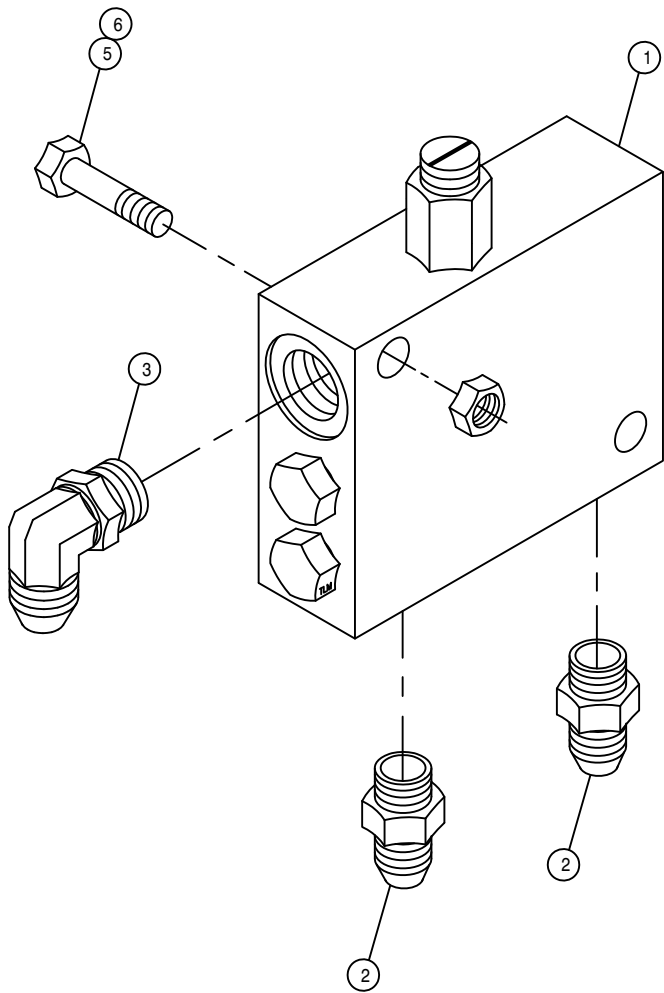

LOOP FLUSHING VALVE ASSEMBLY

DET. QTY PART NO. DESCRIPTION

1	2	610580	REMOTE FLUSHING VALVE, SUND
2	4	618126	9/16MJC-9/16MOR ADPTR
3	1	618119	9/16MJC-90-9/16MOR LBO
4	1	618629	9/16MOR BRANCH TEE-9/16MJC
5	4	900133	3/8UNC X 2" HEX BOLT
6	4	914004	3/8UNC HEX STOVER NUT

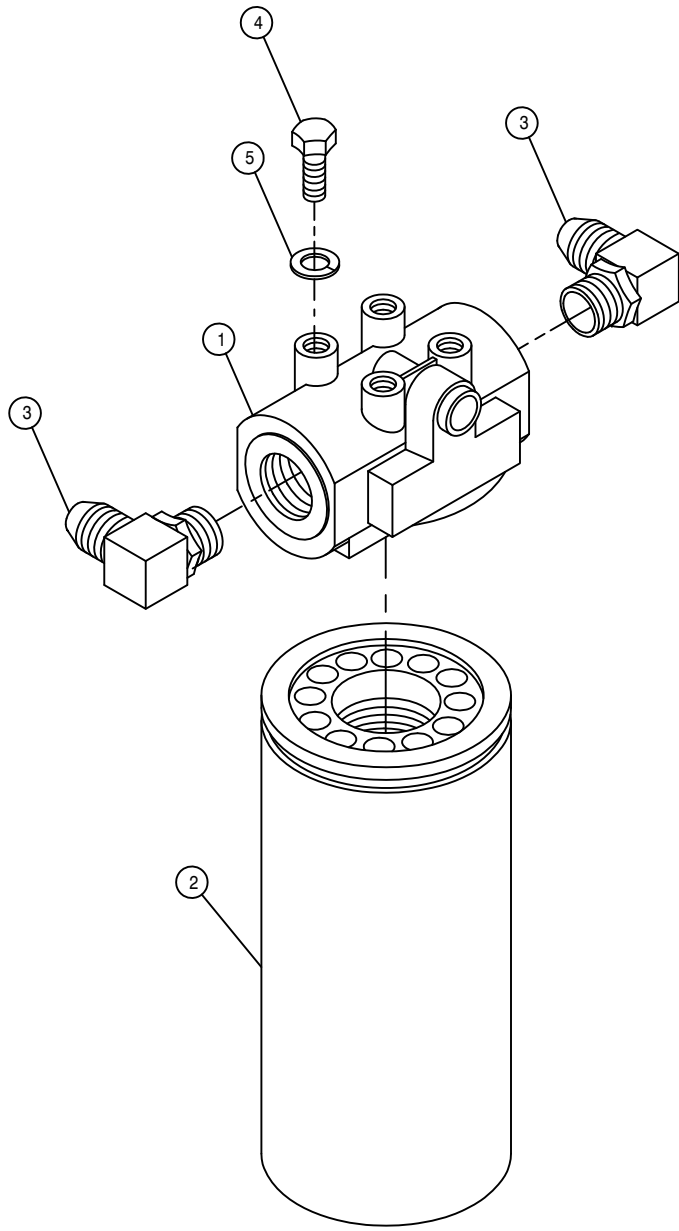

HI -PRESS FILTER ASSEMBLY

DET. QTY PART NO. DESCRIPTION

1	1	605608	HYD FILTER HEAD, DONALDSON
2	1	605609	HYD FILTER ELEMENT, DONALDSON
3	2	618474	3/4MJIC-90-1 1/16MOR LBO
4	4	900128	3/8UNC X 3/4 HEX BOLT
5	4	920502	3/8 LOCK WASHER

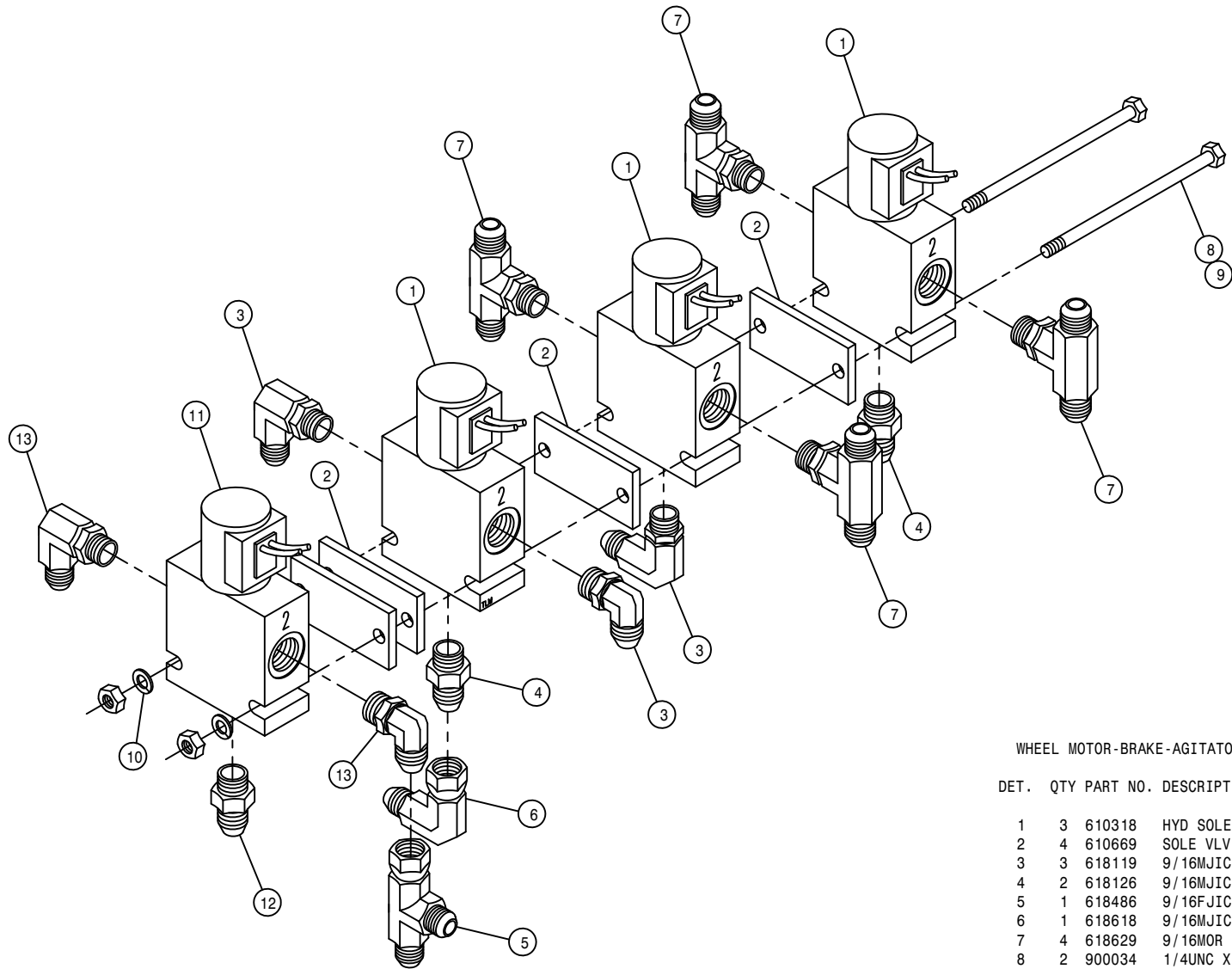

WHEEL MOTOR-BRAKE-AGITATOR VALVE ASSEMBLY

DET. QTY PART NO. DESCRIPTION

1	3	610318	HYD SOLE VLV,2P-3W,9/16FOR,12V
2	4	610669	SOLE VLV SPACER
3	3	618119	9/16MJIC-90-9/16MOR LBO
4	2	618126	9/16MJIC-9/16MOR ADPTR
5	1	618486	9/16FJIC SW RUN TEE-9/16MJIC
6	1	618618	9/16MJIC-90-9/16FJIC SWIV LBO
7	4	618629	9/16MOR BRANCH TEE-9/16MJIC
8	2	900034	1/4UNC X 7" HEX BOLT
9	2	910000	1/4UNC HEX NUT
10	2	920500	1/4 LOCK WASHER
11	1	610674	HYD SOLE VLV,2P3W,3/4FOR,12V
12	1	618109	9/16MJIC-3/4MOR ADPTR
13	2	618115	9/16MJIC-90-3/4MOR LBO

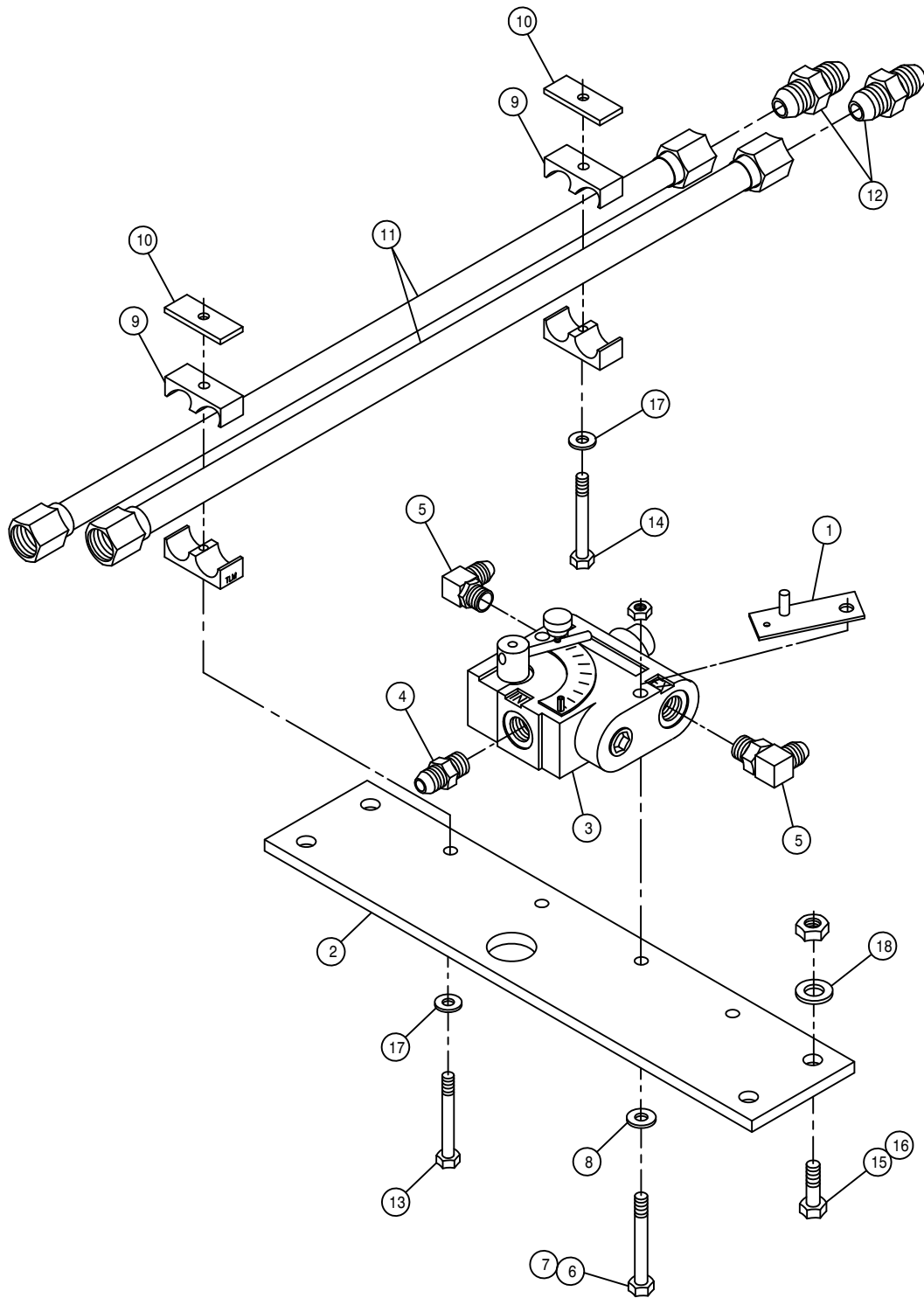

SOLUTION PUMP VARIABLE FLOW CONTROL ASSEMBLY

DET.	QTY	PART NO.	DESCRIPTION
1	1	342306	SOLU PUMP VFC STOP WLD,96 96
2	1	361477	TIE PLT, 2100 98
3	1	606818	FLO CONT FCR51 0-16GPM 7/8FOR
4	1	611126	7/8MJIC-7/8MOR ADPTR
5	2	611128	7/8MJIC-90-7/8MOR LBO
6	2	900009	1/4UNC X 2 3/4 HEX BOLT
7	2	914000	1/4UNC HEX STOVER NUT
8	2	920000	1/4 SAE FLAT WASHER
9	4	470274	TUBE CLAMP BODY, .750-.750
10	4	470278	CLAMP WELD PLATE, SNGL, 2.75LG
11	4	615724	FRT MAIN HYD TUBE ASSY,2100 98
12	4	618177	1 1/16MJIC UNION
13	2	900069	5/16UNC X 2" HEX BOLT
14	2	900086	5/16UNC X 2 1/4 HEX BOLT
15	4	900265	1/2UNC X 1 1/2 HEX BOLT
16	4	914008	1/2UNC HEX STOVER NUT
17	4	920001	5/16 SAE FLAT WASHER
18	4	920004	1/2 SAE FLAT WASHER

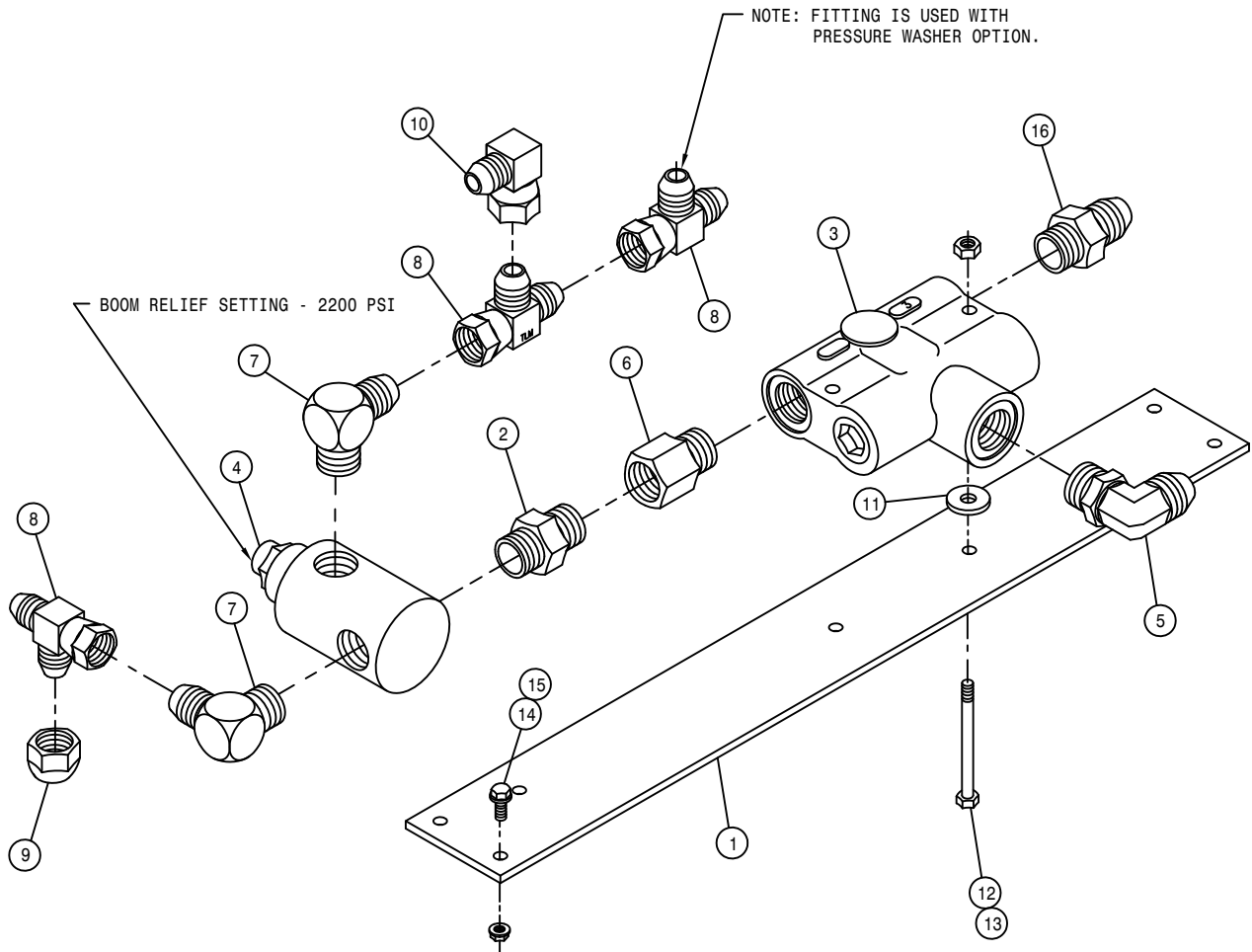

FLOW DIVIDER VALVE ASSEMBLY

DET.	QTY	PART NO.	DESCRIPTION	
	1	361478	REAR FLOW DIV PLT, 2100	98
	1	500000	1/2MNPT HEX PIPE NIPPLE STL	
	1	610307	FLO DIV BG53 3GPM PRI 7/8FOR	
	1	607512	RELIEF VALVE, RL50, 1850 PSI	
	1	611128	7/8MJIC-90-7/8MOR LBO	
	1	618072	7/8MOR-1/2FNPT ADPTR	
	2	618107	9/16MJIC-90-1/2MNPT LBO	
	3	618486	9/16FJIC SW RUN TEE-9/16MJIC	
	1	618531	9/16FJIC CAP NUT	
	1	618618	9/16MJIC-90-9/16FJIC SWIV LBO	
	2	748500	RUBER WASH 3/8X1/4IDX1 1/2 OD	
	2	900008	1/4UNC X 2 1/2 HEX BOLT	
	2	914000	1/4UNC HEX STOVER NUT	
	4	470118	1/4UNC X 3/4 FLANGE HEX BOLT	
	4	470121	1/4UNC HEX FLANGE LOCK NUT	
	1	618310	9/16MJIC-7/8MOR ADPTR	

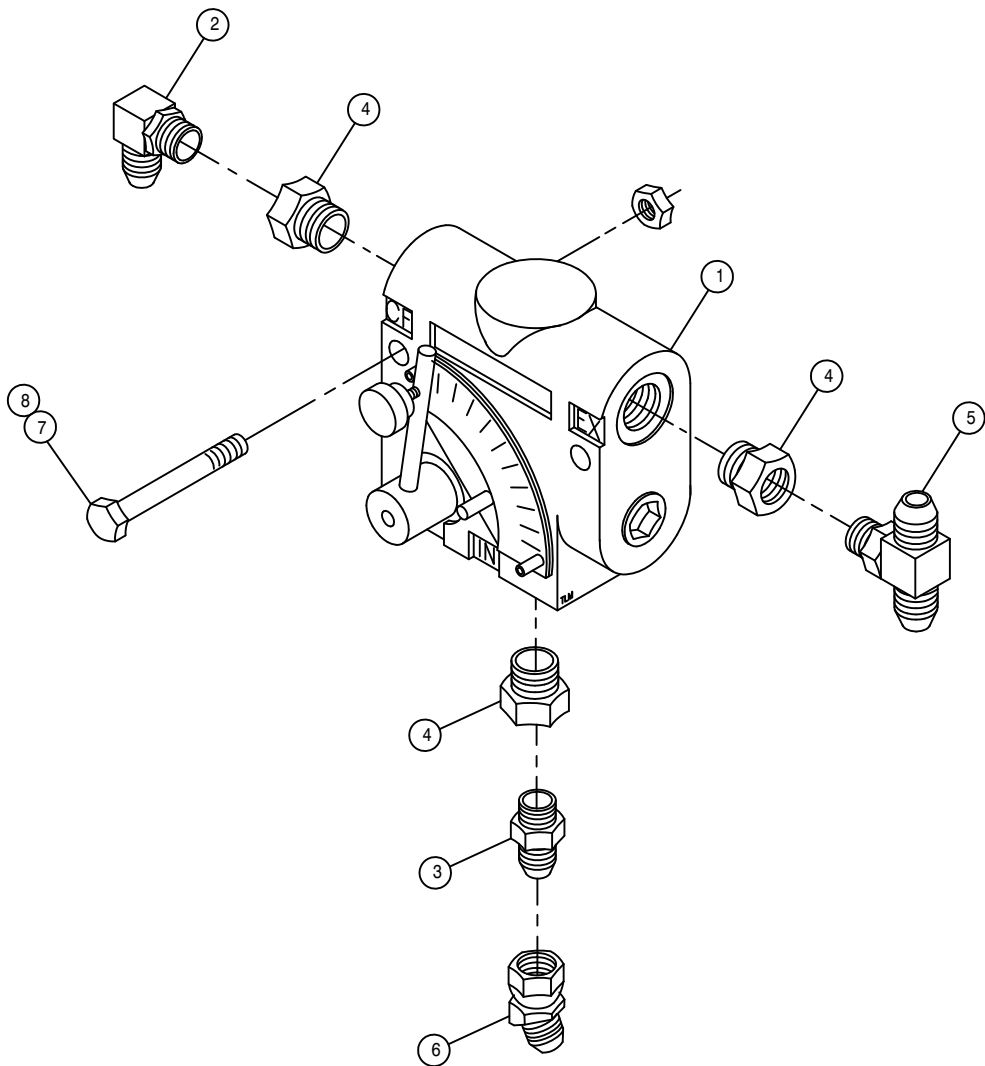

AGITATOR VARIABLE FLOW CONTROL ASSEMBLY

DET. QTY PART NO. DESCRIPTION

1	1	606827	FLO CONT FC51 0-3 VARI 7/8FOR
2	1	618119	9/16MJIC-90-9/16MOR LBO
3	1	618126	9/16MJIC-9/16MOR ADPTR
4	3	618172	7/8MOR-9/16FOR ADPTR
5	1	618629	9/16MOR BRANCH TEE-9/16MJIC
6	1	618634	9/16MJIC-45-9/16FJIC SWIV LBO
7	2	900008	1/4UNC X 2 1/2 HEX BOLT
8	2	914000	1/4UNC HEX STOVER NUT

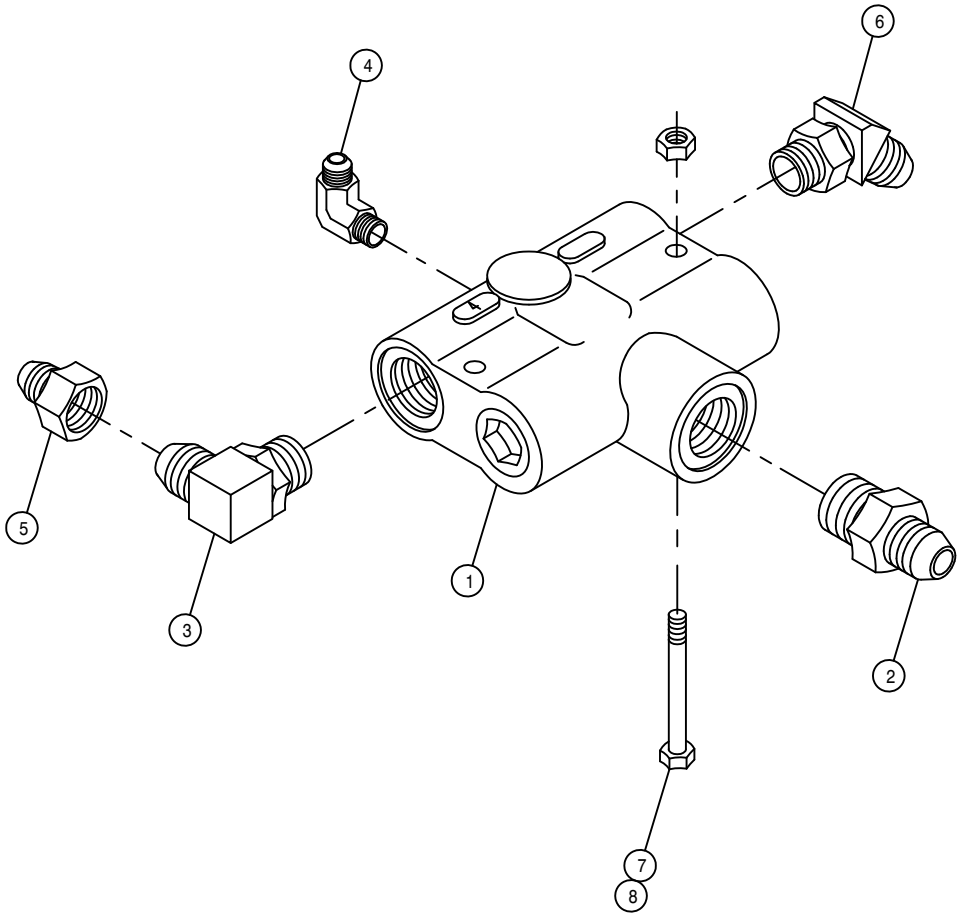

BGR56 FLOW DIVIDER ASSEMBLY

DET.	QTY	PART NO.	DESCRIPTION
1	1	607528	FLO DIV BGR54 4GPM PRI 7/8FOR
2	1	611126	7/8MJIC-7/8MOR ADPTR
3	1	611128	7/8MJIC-90-7/8MOR LBO
4	1	618015	9/16MJIC-90-3/8MNPT LBO
5	1	618557	7/8FJIC-9/16MJIC ADPTR
6	1	618644	7/8MJIC-45-7/8MOR LBO
7	2	900008	1/4UNC X 2 1/2 HEX BOLT
8	2	914000	1/4UNC HEX STOVER NUT



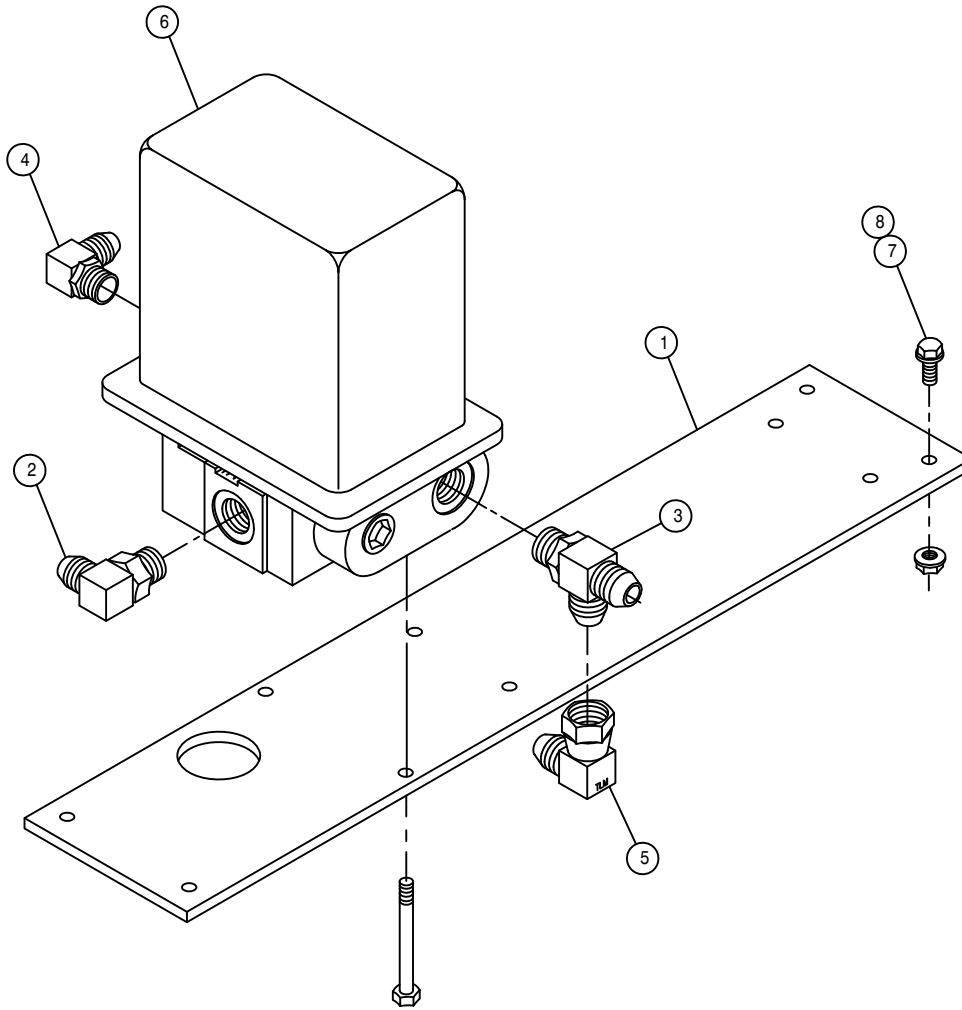

RAVEN HYDRAULIC CONTROL VALVE ASSEMBLY

DET. QTY PART NO. DESCRIPTION

1	1	361476	ELECT VLV MTG PLT, 2100	98
2	1	611128	7/8MJIC-90-7/8MOR LBO	
3	1	618130	7/8MOR RUN TEE-7/8MJIC	
4	1	618183	3/4MJIC-90-7/8MOR LBO	
5	1	618301	7/8MJIC-90-7/8FJIC SWIV LBO	
6	1	690621	VALVE HYD CTRL, 16GPM RAVEN	
7	4	470118	1/4UNC X 3/4 FLANGE HEX BOLT	
8	4	470121	1/4UNC HEX FLANGE LOCK NUT	

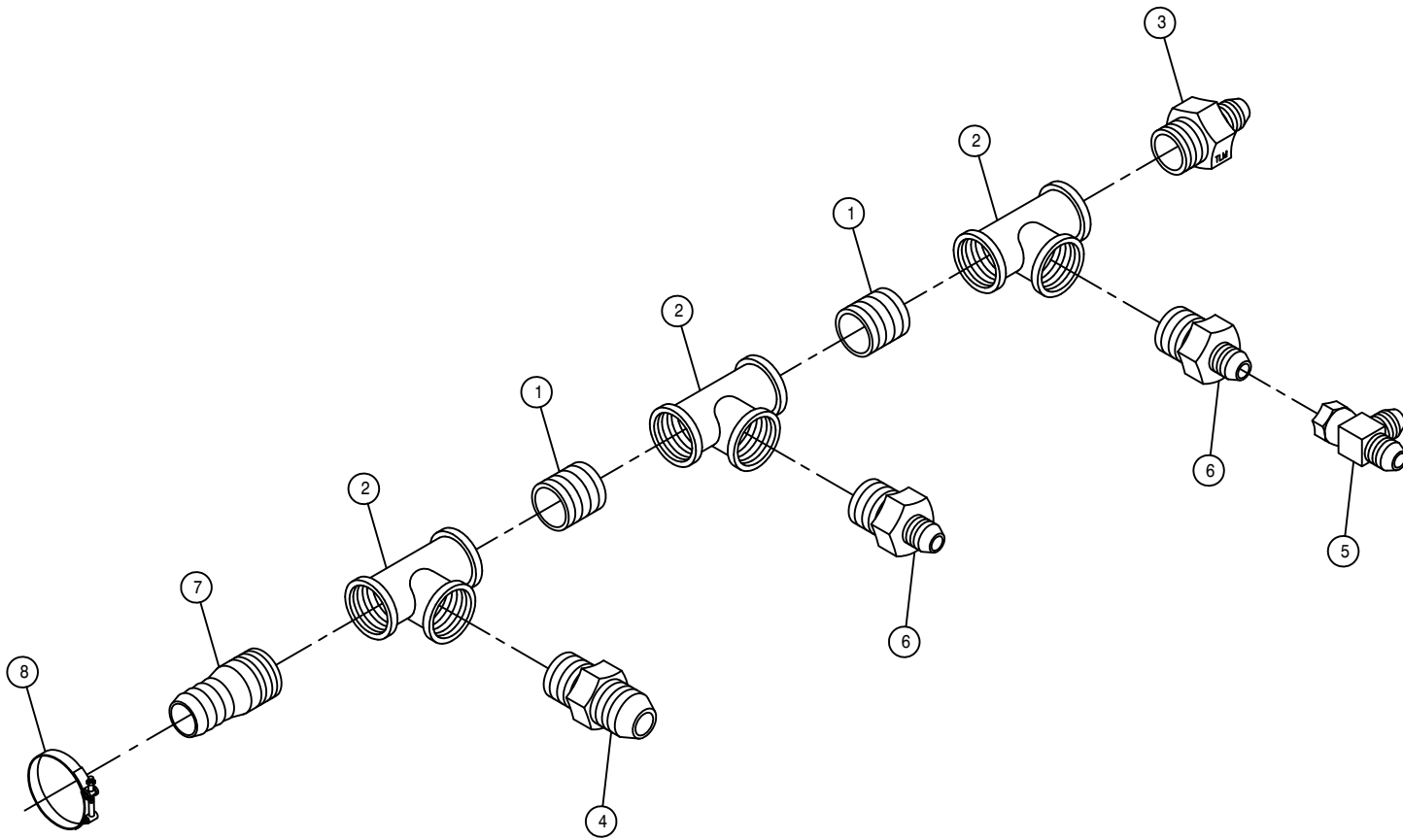

## RETURN TEE ASSEMBLY

DET.	QTY	PART NO.	DESCRIPTION
1	2	504702	CLOSE NIPPLE .75NPT
2	3	504955	BLK PIPE TEE .75NPT
3	1	610300	3/4MJIC-3/4MNPT ADPTR
4	1	618059	7/8MJIC-3/4MNPT ADPTR
5	1	618486	9/16MJIC SW RUN TEE-9/16MJIC
6	2	618642	9/16MJIC-3/4MNPT ADPTR
7	1	713220	HOSE BARB 3/4 NPT X 3/4
8	1	520137	1.19/1.37 T-BOLT HOSE CLAMP

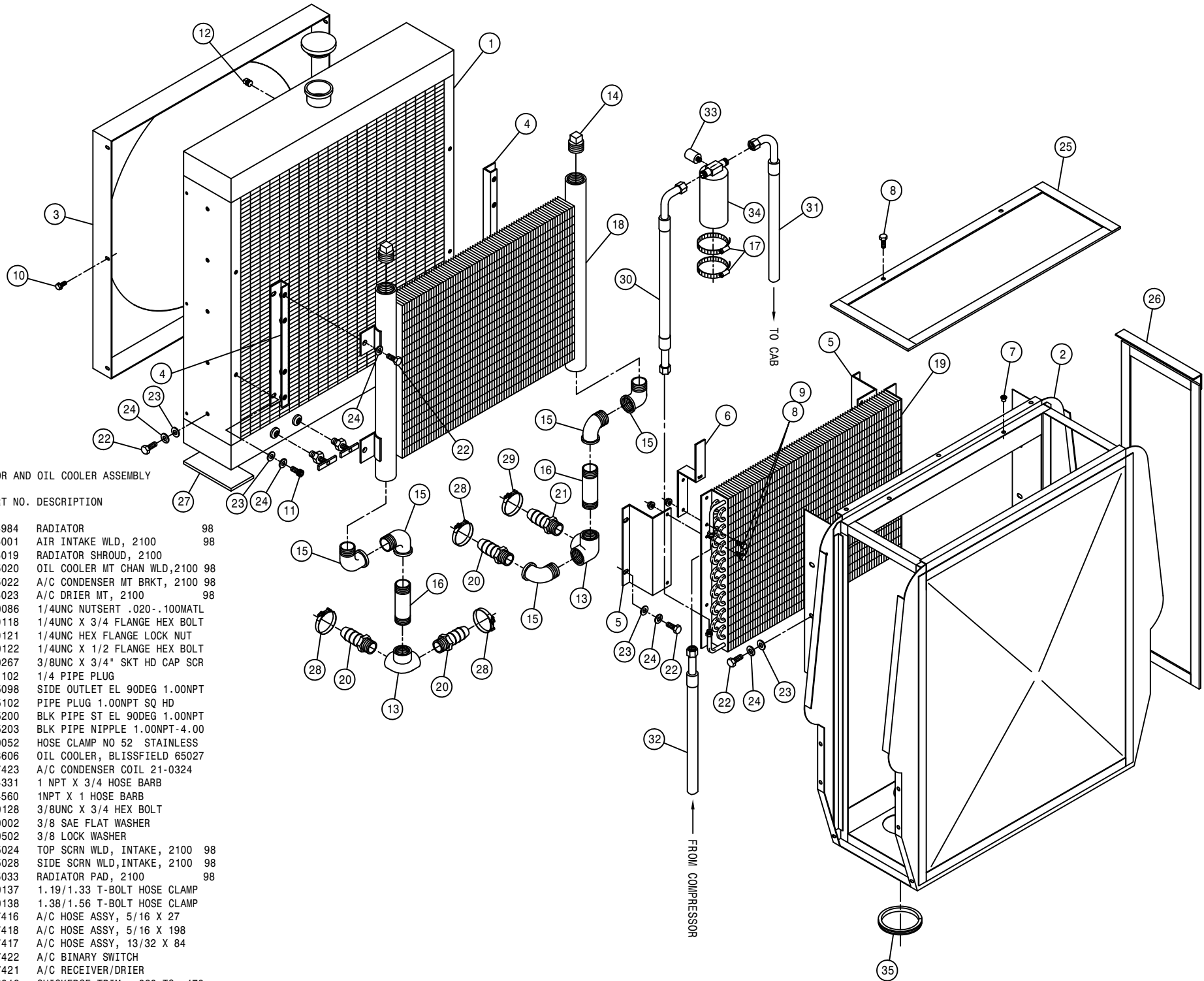

RADIATOR AND OIL COOLER ASSEMBLY

DET. QTY PART NO. DESCRIPTION

1	1	314984	RADIATOR	98
2	1	315001	AIR INTAKE WLD, 2100	98
3	1	315019	RADIATOR SHROUD, 2100	98
4	2	315020	OIL COOLER MT CHAN WLD, 2100	98
5	2	315022	A/C CONDENSER MT BRKT, 2100	98
6	1	315023	A/C DRIER MT, 2100	98
7	14	470086	1/4UNC NUTSERT .020-.100MATL	
8	8	470118	1/4UNC X 3/4 FLANGE HEX BOLT	
9	6	470121	1/4UNC HEX FLANGE LOCK NUT	
10	6	470122	1/4UNC X 1/2 FLANGE HEX BOLT	
11	4	470267	3/8UNC X 3/4" SKT HD CAP SCR	
12	1	501102	1/4 PIPE PLUG	
13	2	505098	SIDE OUTLET EL 90DEG 1.00NPT	
14	2	505102	PIPE PLUG 1.00NPT SQ HD	
15	5	505200	BLK PIPE ST EL 90DEG 1.00NPT	
16	2	505203	BLK PIPE NIPPLE 1.00NPT-4.00	
17	2	520052	HOSE CLAMP NO 52 STAINLESS	
18	1	618606	OIL COOLER, BLISSFIELD 65027	
19	1	657423	A/C CONDENSER COIL 21-0324	
20	3	714331	1 NPT X 3/4 HOSE BARB	
21	1	714560	1NPT X 1 HOSE BARB	
22	18	900128	3/8UNC X 3/4 HEX BOLT	
23	18	920002	3/8 SAE FLAT WASHER	
24	22	920502	3/8 LOCK WASHER	
25	1	315024	TOP SCR N WLD, INTAKE, 2100	98
26	2	315028	SIDE SCR N WLD, INTAKE, 2100	98
27	2	315033	RADIATOR PAD, 2100	98
28	3	520137	1.19/1.33 T-BOLT HOSE CLAMP	
29	1	520138	1.38/1.56 T-BOLT HOSE CLAMP	
30	1	657416	A/C HOSE ASSY, 5/16 X 27	
31	1	657418	A/C HOSE ASSY, 5/16 X 198	
32	1	657417	A/C HOSE ASSY, 13/32 X 84	
33	1	657422	A/C BINARY SWITCH	
34	1	657421	A/C RECEIVER/DRIER	
35	2	193016	QUICKEDGE TRIM .060 TO .170	

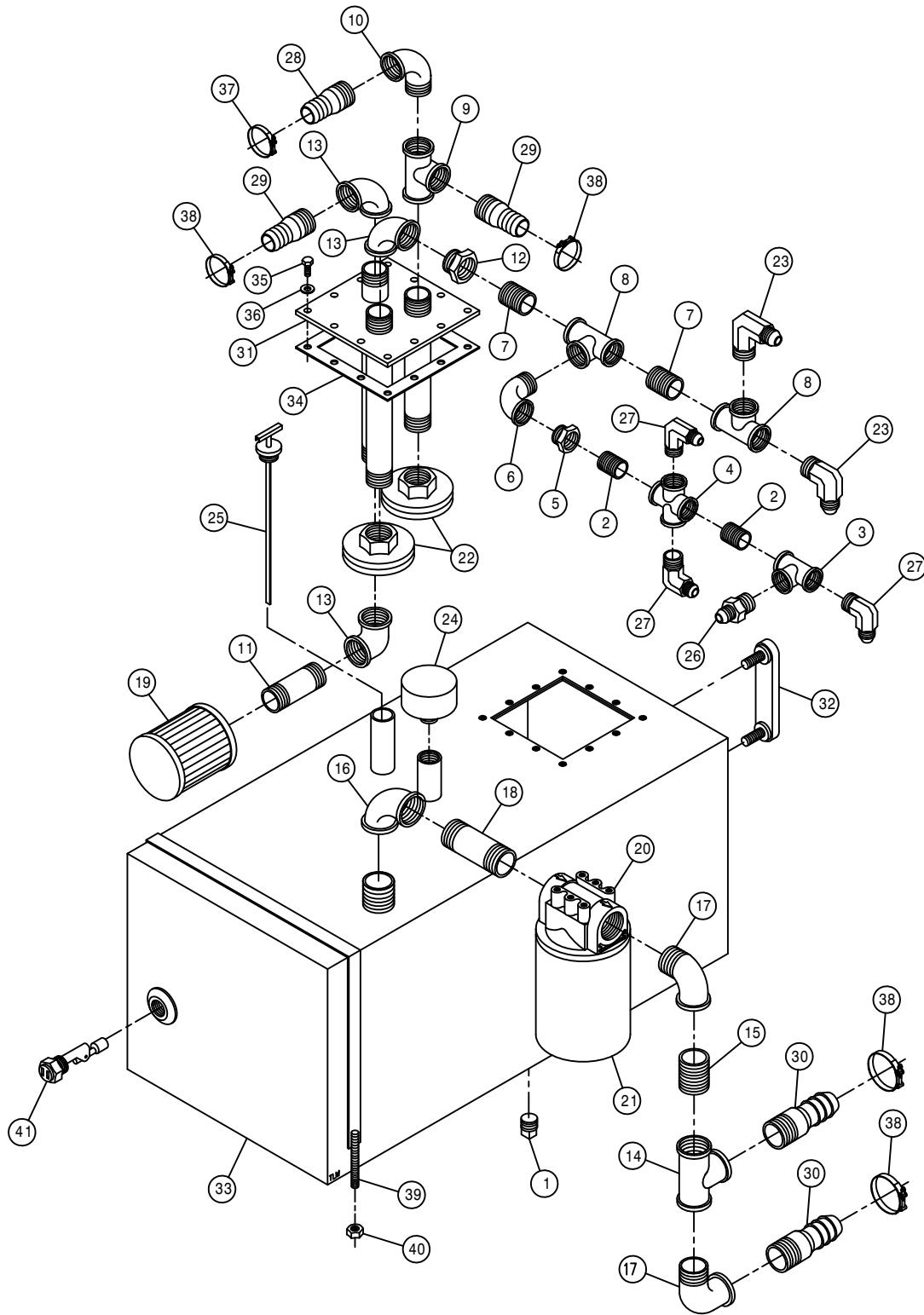

HYDRAULIC TANK ASSEMBLY

DET.	QTY	PART NO.	DESCRIPTION
1	1	501102	1/4 PIPE PLUG
2	2	503600	CLOSE NIPPLE .50NPT
3	1	503820	BLK PIPE TEE .50NPT
4	1	503824	BLK PIPE CROSS .50NPT
5	1	504210	RED BUSH 3/4 NPT X 1/2 NPT
6	1	504610	BLK PIPE ST EL 90DEG .75NPT
7	2	504702	CLOSE NIPPLE .75NPT
8	2	504955	BLK PIPE TEE .75NPT
9	1	505101	BLK PIPE TEE 1.00NPT
10	1	505200	BLK PIPE ST EL 90DEG 1.00NPT
11	1	505203	BLK PIPE NIPPLE 1.00NPT-4.00
12	1	505213	RED BUSH 1 X 3/4 BLK MAL
13	3	505300	BLK PIPE EL 90DEG 1.00NPT
14	1	506105	BLK PIPE TEE 1.25NPT
15	1	506200	CLOSE NIPPLE 1.25NPT
16	1	506303	BLK PIPE EL 90DEG 1.25NPT
17	2	506410	BLK PIPE ST EL 90DEG 1.25NPT
18	1	506604	BLK PIPE NIPPLE 1.25NPT-4.00
19	1	605600	MICHIGAN RESERVOIR FILTER
20	1	605601	PARKER FILTER ASSY, 10M, 1.25NPT
21	1	605602	PARKER FILTER ELEMENT, 10MICRON
22	2	605603	LINE SUMP DIFFUSER
23	2	610305	3/4MJIC-90-3/4MNPT LBO
24	1	611052	FILLER BREATHER 3/4NPT
25	1	614453	DIPSTICK, 8IN
26	1	618018	9/16MJIC-1/2MNPT ADPTR
27	3	618107	9/16MJIC-90-1/2MNPT LBO
28	1	714331	1 NPT X 3/4 HOSE BARB
29	2	714560	1NPT X 1 HOSE BARB
30	2	715664	1 1/4 NPT X 1 HOSE BARB
31	1	760090	RECEIVER PLT WLD 8240
32	1	760177	SIGHT GAUGE W/TEMP, HYD TANK
33	1	760205	HYD TANK WELD, 2100 98
34	1	763039	HYD MTR MTG PLT GSKT
35	12	900064	5/16UNC X 3/4 HEX BOLT
36	12	920001	5/16 SAE FLAT WASHER
37	1	520137	1.19/1.33 T-BOLT HOSE CLAMP
38	4	520138	1.38/1.56 T-BOLT HOSE CLAMP
39	2	760212	HYD TANK STRAP WLD, 2100 98
40	4	914004	3/8UNC HEX STOVER NUT
41	1	470290	LIQUID LEVEL SWITCH, 1/2MNPT

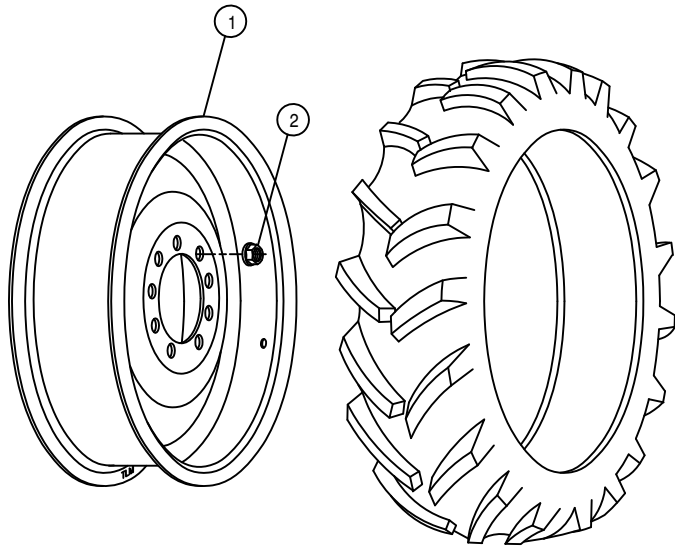

290/95R 34 \*\*\* RADIAL TIRE

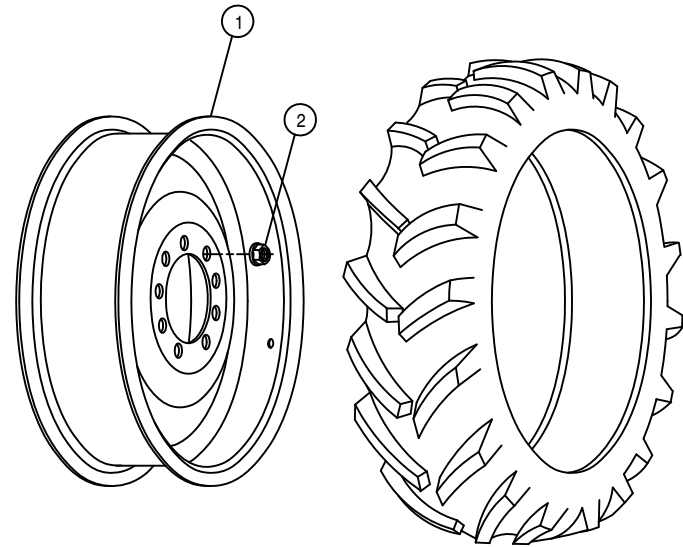

320/85R 34 \*\*\* RADIAL TIRE

TIRE AND RIM ASSEMBLIES

DET.	QTY	PART NO.	DESCRIPTION	
1	2	821042	RIM WLD, W10-34	98
2	18	470140	5/8UNF HEX SMTH FLANGE NUT PLT	

RIGHT FRONT LEG ASSEMBLY

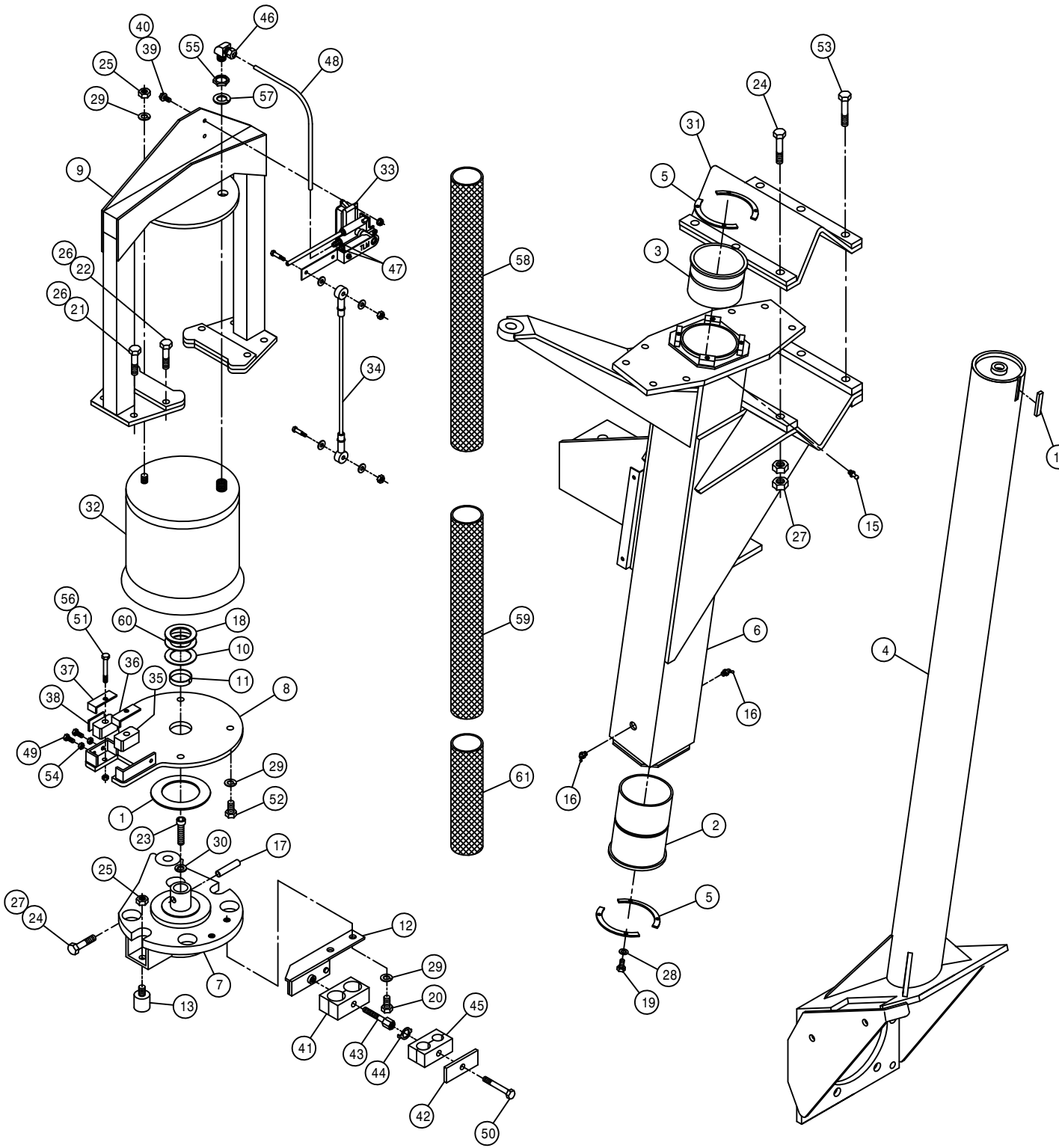

DET.	QTY	PART NO.	DESCRIPTION
1	1	127505	THRUST BEARING, FIBERGLIDE
2	1	358564	FRT LEG LWR NYL SLEEVE 280 89
3	1	358565	FRT LEG UPR NYL SLEEVE 280 89
4	1	358868	RH FRT INNER LEG WLD, 2100 98
5	4	358927	LWR BRG KPR, LEG 98
6	1	358954	RH FRT OUTER LEG WLD, 2100 99
7	1	358971	STEERING ARM WLD,RF/LR 2100 99
8	1	358980	AIR BAG MT WLD, RF/LR 2100 99
9	1	358985	AIR BAG ARCH WLD,RF/LR 2100 99
10	1	358994	LEG WASHER, NYLON 2100 99
11	1	358995	NYLON BEARING,LWR AB MT2100 99
12	1	358996	RH UPPER HOSE MT WELD, 2100 99
13	2	470259	URETHANE BUMPER,1.25D X 1.25L
14	1	470265	KEY, .250 X .375 X 1.88 LG
15	1	471005	1/4 28 X 1/2 GREASE ZERK
16	2	471023	GREASE ZERK 1/4-28 X 45
17	1	473906	SPIRAL PIN, 1/2 X 2 1/2 LG
18	1	483061	1.65 ID X 2.50 OD X .188T WASH
19	8	900064	5/16UNC X 3/4 HEX BOLT
20	2	900263	1/2UNC X 1" HEX BOLT
21	4	900265	1/2UNC X 1 1/2 HEX BOLT
22	4	900266	1/2UNC X 1 3/4 HEX BOLT
23	1	900390	5/8UNC X 2 1/2 SOCKET CAP SCR
24	4	900836	5/8UNF X 3 1/4 HEX BOLT GR8
25	3	910008	1/2UNC HEX NUT
26	8	914008	1/2UNC HEX STOVER NUT
27	14	914811	5/8UNF HEX NUT GR8
28	8	920501	5/16 LOCK WASHER
29	7	920504	1/2 LOCK WASHER
30	1	920505	5/8 LOCK WASHER
31	1	358759	LEG MT V-PLT WLD, 284T 94
32	1	358831	AIRIDE SPRING 98
33	1	358832	AIRIDE SPRING CTRL VALVE 98
34	1	358839	AIRRIIDE CTRL LINK KIT, 2100 99
35	2	358990	NYLON GUIDE, 2100 LEG 99
36	1	358991	INNER KEEPER,NYL GUIDE,2100 99
37	1	358992	OUTER KEEPER,NYL GUIDE,2100 99
38	1	358993	NYLON GUIDE BACK PLATE,2100 99
39	2	470118	1/4UNC X 3/4 FLANGE HEX BOLT
40	2	470121	1/4UNC HEX FLANGE LOCK NUT
41	1	470271	HOSE CLAMP BODY,1.200-1.200
42	1	470276	CLAMP COVER PLATE,SNGL, 2.55LG
43	1	470280	STACK BOLT, 5/16UNC X 1 3/4
44	1	470281	STACK BOLT SAFETY LOCK PLATE
45	1	470282	HOSE CLAMP BODY, .53-.78
46	1	711016	1/4NPT-90-1/4NYL TUBE FTG BR8
47	2	711023	1/8MNPT-1/4OD NYL TUBE FTG BR8
48	1	601413	HOSE, 1/4 X 8 AIR
49	2	900065	5/16UNC X 1" HEX BOLT
50	1	900068	5/16UNC X 1 3/4 HEX BOLT
51	2	900069	5/16UNC X 2" HEX BOLT
52	4	900264	1/2UNC X 1 1/4 HEX BOLT
53	3	900837	5/8UNF X 3 1/2 HEX BOLT GR8
54	2	910002	5/16UNC HEX NUT
55	1	910013	3/4UNF HEX NUT
56	2	914002	5/16UNC HEX STOVER NUT
57	1	920506	3/4 LOCK WASHER
58	1	342637	NYL HOSE SLEEVE,2.96ID X 54.00
59	1	342335	NYL HOSE SLEEVE,2.64ID X 36.00
60	1	483063	1.65 ID X 2.50 OD X .074T WASH
61	1	342654	NYL HOSE SLEEVE,3.66ID X 24.00

RIGHT FRONT LEG ASSEMBLY

DET.	QTY	PART NO.	DESCRIPTION
1	1	359015	FRT WHL MTR SHLD WLD,2100 00
2	1	358926	FRT LEG HYD TUBE BRKT, 2100 98
3	1	470066	1/2UNC X 1/2 AL HD CUP SET SCR
4	1	470272	TUBE CLAMP BODY, .375-.500
5	1	470275	TUBE CLAMP BODY,1.000-1.000
6	1	470277	CLAMP WELD PLATE, SNGL, 2.15LG
7	1	470278	CLAMP WELD PLATE, SNGL, 2.75LG
8	1	471023	GREASE ZERK 1/4-28 X 45
9	1	610634	ZERK BOLT, 1 1/2, TORQ HUB
10	1	610686	TORQ HUB, 18:1 B-MT MW3BA
11	1	610637	SUND HYD MOTOR, M46-4019
12	1	615708	LWR HYD TUBE ASSY,LEG 2100 98
13	1	615709	UPR HYD TUBE ASSY,LEG 2100 98
14	1	615710	RF/LR HYD DRN TUBE ASSY2100 98
15	1	615712	RF/LR HYD CTRL TUBE ASSY210098
16	1	618119	9/16MJIC-90-9/16MOR LBO
17	2	618178	1 5/16MJIC-90-1 5/16MOR LBO
18	1	618474	3/4MJIC-90-1 1/16MOR LBO
19	1	662256	STALK GUIDE WLD, 2100 2000
20	1	870045	O-RING 4 1/8 OD X 4 ID
21	1	900068	5/16UNC X 1 3/4 HEX BOLT
22	1	900070	5/16UNC X 2 1/2 BOLT
23	1	920004	1/2 SAE FLAT WASHER
24	3	900264	1/2UNC X 1 1/4 HEX BOLT
25	3	900265	1/2UNC X 1 1/2 HEX BOLT
26	1	900266	1/2UNC X 1 3/4 HEX BOLT
27	6	900333	5/8UNC X 1 1/2 HEX BOLT
28	2	914002	5/16UNC HEX STOVER NUT
29	6	914008	1/2UNC HEX STOVER NUT
30	2	920504	1/2 LOCK WASHER
31	6	920505	5/8 LOCK WASHER
32	2	618577	1 5/16MJIC UNION
33	1	618314	3/4MJIC UNION
34	1	619010	9/16MJIC UNION
35	9	470140	5/8UNF HEX SMTH FLANGE NUT PLT
36	1	359014	FRT HYD TUBE MTG PLT,2100 00

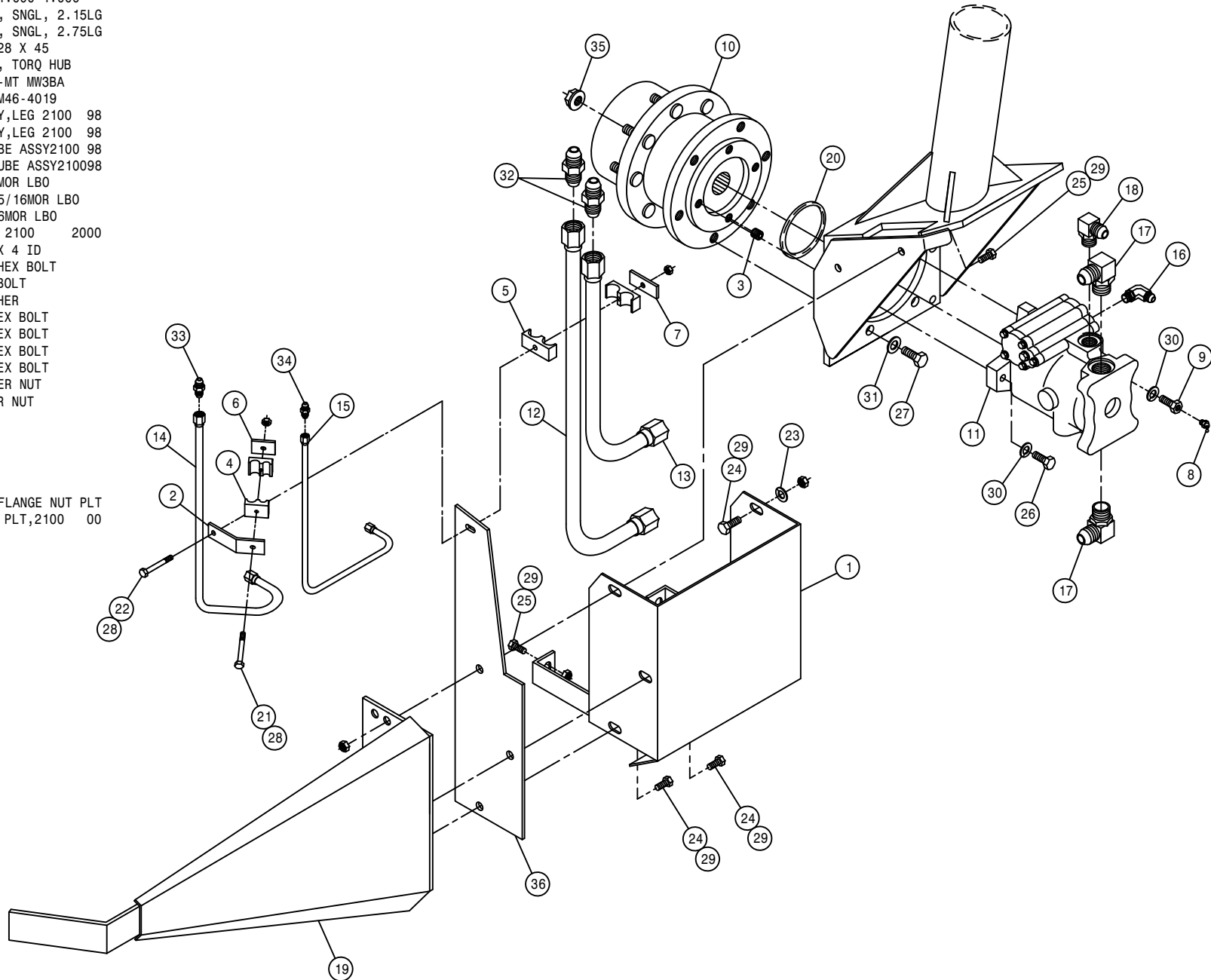

LEFT FRONT LEG ASSEMBLY

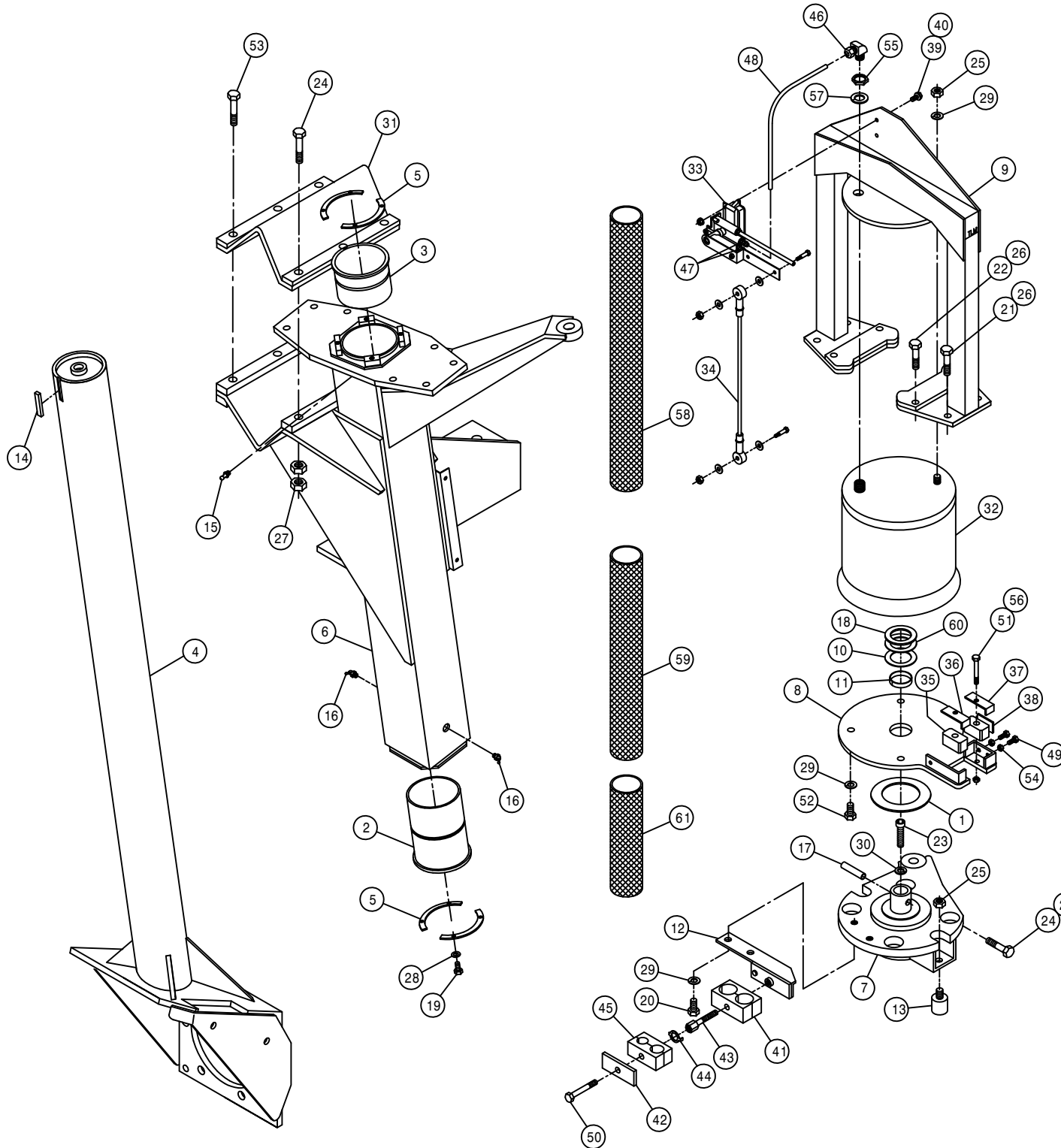

DET.	QTY	PART NO.	DESCRIPTION
	1	127505	THRUST BEARING, FIBERGLIDE
	1	358564	FRT LEG LWR NYL SLEEVE 280 89
	1	358565	FRT LEG UPR NYL SLEEVE 280 89
	1	358869	LH FRT INNER LEG WLD, 2100 98
	4	358927	LWR BRG KPR, LEG 98
	1	358955	LH FRT OUTER LEG WLD, 2100 99
	1	358972	STEERING ARM WLD, LF/RR 2100 99
	1	358981	AIR BAG MT WLD, LF/RR 2100 99
	1	358986	AIR BAG ARCH WLD, LF/RR 2100 99
	1	358994	LEG WASHER, NYLON 2100 99
	1	358995	NYLON BEARING, LWR AB MT2100 99
	1	358997	LH UPPER HOSE MT WELD, 2100 99
	2	470259	URETHANE BUMPER, 1.25D X 1.25L
	1	470265	KEY, .250 X .375 X 1.88 LG
	1	471005	1/4 28 X 1/2 GREASE ZERK
	2	471023	GREASE ZERK 1/4-28 X 45
	1	473906	SPIRAL PIN, 1/2 X 2 1/2 LG
	1	483061	1.65 ID X 2.50 OD X .188T WASH
	8	900064	5/16UNC X 3/4 HEX BOLT
	2	900263	1/2UNC X 1" HEX BOLT
	4	900265	1/2UNC X 1 1/2 HEX BOLT
	4	900266	1/2UNC X 1 3/4 HEX BOLT
	1	900390	5/8UNC X 2 1/2 SOCKET CAP SCR
	4	900836	5/8UNF X 3 1/4 HEX BOLT GR8
	3	910008	1/2UNC HEX NUT
	8	914008	1/2UNC HEX STOVER NUT
	14	914811	5/8UNF HEX NUT GR8
	8	920501	5/16 LOCK WASHER
	7	920504	1/2 LOCK WASHER
	1	920505	5/8 LOCK WASHER
	1	358759	LEG MT V-PLT WLD, 284T 94
	1	358831	AIRIDE SPRING 98
	1	358832	AIRIDE SPRING CTRL VALVE 98
	1	358839	AIRIDE CTRL LINK KIT, 2100 99
	2	358990	NYLON GUIDE, 2100 LEG 99
	1	358991	INNER KEEPER, NYL GUIDE, 2100 99
	1	358992	OUTER KEEPER, NYL GUIDE, 2100 99
	1	358993	NYLON GUIDE BACK PLATE, 2100 99
	2	470118	1/4UNC X 3/4 FLANGE HEX BOLT
	2	470121	1/4UNC HEX FLANGE HEX NUT
	1	470271	HOSE CLAMP BODY, 1.200-1.200
	1	470276	CLAMP COVER PLATE, SNGL, 2.55LG
	1	470280	STACK BOLT, 5/16UNC X 1 3/4
	1	470281	STACK BOLT SAFETY LOCK PLATE
	1	470282	HOSE CLAMP BODY, .53-.78
	1	711016	1/4NPT-90-1/4NYL TUBE FTG BR8
	2	711023	1/8MNPT-1/4OD NYL TUBE FTGBRS
	1	601413	HOSE, 1/4 X 8 AIR
	2	900065	5/16UNC X 1" HEX BOLT
	1	900068	5/16UNC X 1 3/4 HEX BOLT
	2	900069	5/16UNC X 2" HEX BOLT
	4	900264	1/2UNC X 1 1/4 HEX BOLT
	3	900837	5/8UNF X 3 1/2 HEX BOLT GR8
	2	910002	5/16UNC HEX NUT
	1	910013	3/4UNF HEX NUT
	2	914002	5/16UNC HEX STOVER NUT
	1	920506	3/4 LOCK WASHER
	1	342637	NYL HOSE SLEEVE, 2.96ID X 54.00
	1	342335	NYL HOSE SLEEVE, 2.64ID X 36.00
	1	483063	1.65 ID X 2.50 OD X .074T WASH
	1	342654	NYL HOSE SLEEVE, 3.66ID X 24.00



LEFT FRONT LEG ASSEMBLY

DET. QTY PART NO. DESCRIPTION

DET.	QTY	PART NO.	DESCRIPTION
1	1	359015	FRT WHL MTR SHLD WLD,2100 00
2	1	358926	FRT LEG HYD TUBE BRKT, 2100 98
3	1	470066	1/2UNC X 1/2 AL HD CUP SET SCR
4	1	470272	TUBE CLAMP BODY,.375-.500
5	1	470275	TUBE CLAMP BODY,1.000-1.000
6	1	470277	CLAMP WELD PLATE, SNGL, 2.15LG
7	1	470278	CLAMP WELD PLATE, SNGL, 2.75LG
8	1	471023	GREASE ZERK 1/4-28 X 45
9	1	610634	ZERK BOLT, 1 1/2, TORQ HUB
10	1	610686	TORQ HUB, 18:1 B-MT MW3BA
11	1	610637	SUND HYD MOTOR, M46-4019
12	1	615708	LWR HYD TUBE ASSY,LEG 2100 98
13	1	615709	UPR HYD TUBE ASSY,LEG 2100 98
14	1	615711	LF/RR HYD DRN TUBE ASSY2100 98
15	1	615713	LF/RR HYD CTRL TUBE ASSY210098
16	1	618119	9/16MJIC-90-9/16MOR LBO
17	2	618178	1 5/16MJIC-90-1 5/16MOR LBO
18	1	618474	3/4MJIC-90-1 1/16MOR LBO
19	1	662256	STALK GUIDE WLD, 2100 2000
20	1	870045	O-RING 4 1/8 OD X 4 ID
21	1	900068	5/16UNC X 1 3/4 HEX BOLT
22	1	900070	5/16UNC X 2 1/2 BOLT
23	1	920004	1/2 SAE FLAT WASHER
24	3	900264	1/2UNC X 1 1/4 HEX BOLT
25	3	900265	1/2UNC X 1 1/2 HEX BOLT
26	1	900266	1/2UNC X 1 3/4 HEX BOLT
27	6	900333	5/8UNC X 1 1/2 HEX BOLT
28	2	914002	5/16UNC HEX STOVER NUT
29	6	914008	1/2UNC HEX STOVER NUT
30	2	920504	1/2 LOCK WASHER
31	6	920505	5/8 LOCK WASHER
32	2	618577	1 5/16MJIC UNION
33	1	618314	3/4MJIC UNION
34	1	619010	9/16MJIC UNION
35	9	470140	5/8UNF HEX SMTH FLANGE NUT PLT
36	1	359014	FRT HYD TUBE MTG PLT,2100 00

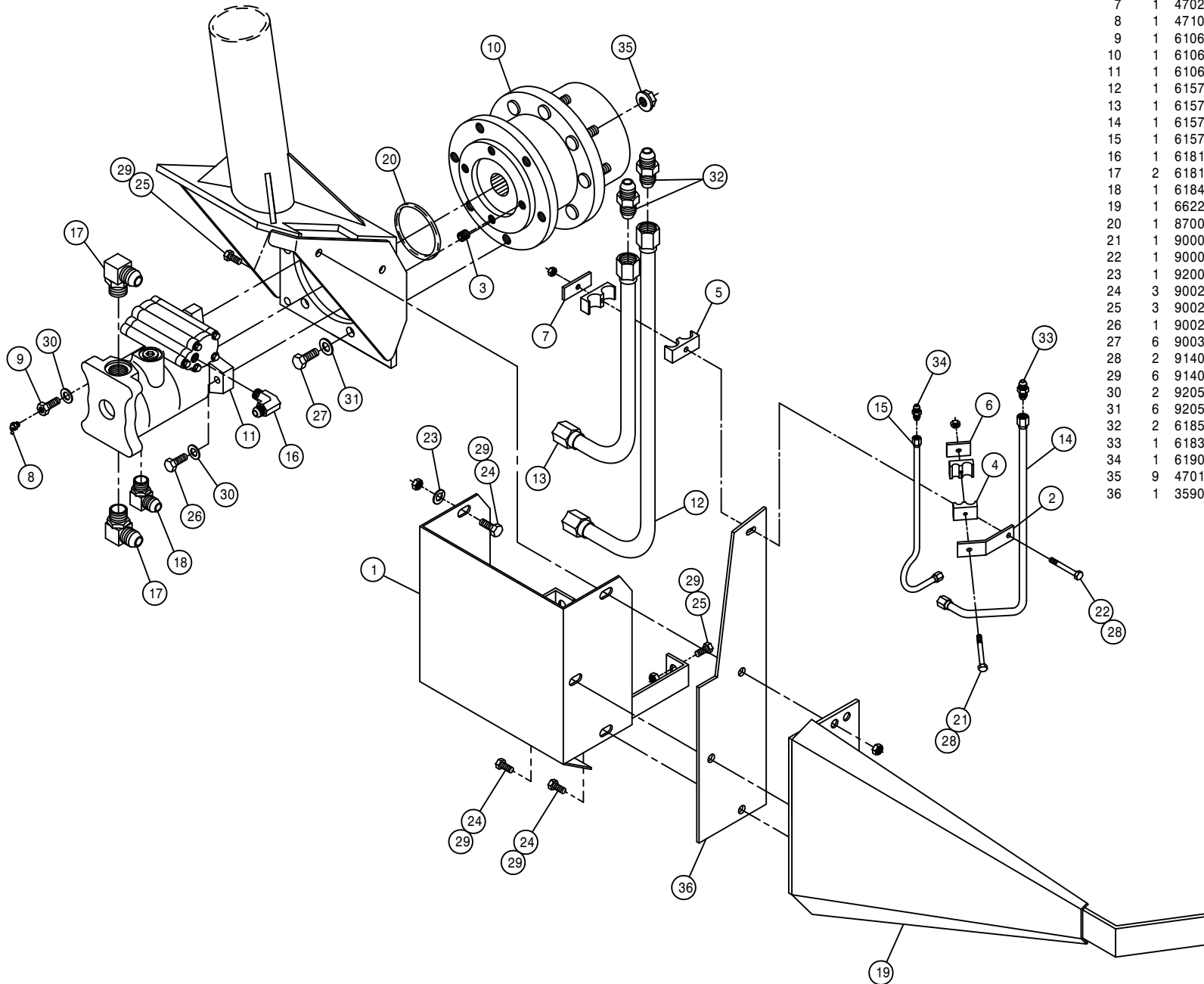

25

225025

RIGHT REAR LEG ASSEMBLY

DET. QTY PART NO. DESCRIPTION

DET.	QTY	PART NO.	DESCRIPTION
1	1	483062	3.00 ID X 4.62 OD X .125T WASH
2	1	358564	FRT LEG LWR NYL SLEEVE 280 89
3	1	358565	FRT LEG UPR NYL SLEEVE 280 89
4	1	358870	RH REAR INNER LEG WLD, 2100 98
5	4	358927	LWR BRG KPR, LEG 98
6	1	358956	RH REAR OUTER LEG WLD,2100 99
7	1	358972	STEERING ARM WLD,LF/RR 2100 99
8	1	358981	AIR BAG MT WLD, LF/RR 2100 99
9	1	358986	AIR BAG ARCH WLD,LF/RR 2100 99
10	1	358994	LEG WASHER, NYLON 2100 99
11	1	358995	NYLON BEARING,LWR AB MT2100 99
12	2	900069	5/16UNC X 2" HEX BOLT
13	2	470259	URETHANE BUMPER,1.25D X 1.25L
14	1	470265	KEY, .250 X .375 X 1.88 LG
15	1	471005	1/4 28 X 1/2 GREASE ZERK
16	2	471023	GREASE ZERK 1/4-28 X 45
17	1	473906	SPIRAL PIN, 1/2 X 2 1/2 LG
18	1	483061	1.65 ID X 2.50 OD X .188T WASH
19	8	900064	5/16UNC X 3/4 HEX BOLT
20	4	900264	1/2UNC X 1 1/4 HEX BOLT
21	4	900265	1/2UNC X 1 1/2 HEX BOLT
22	4	900266	1/2UNC X 1 3/4 HEX BOLT
23	1	900390	5/8UNC X 2 1/2 SOCKET CAP SCR
24	4	900836	5/8UNF X 3 1/4 HEX BOLT GR8
25	3	910008	1/2UNC HEX NUT
26	8	914008	1/2UNC HEX STOVER NUT
27	14	914811	5/8UNF HEX NUT GR8
28	8	920501	5/16 LOCK WASHER
29	5	920504	1/2 LOCK WASHER
30	1	920505	5/8 LOCK WASHER
31	1	358759	LEG MT V-PLT WLD, 284T 94
32	1	358831	AIRIDE SPRING 98
33	1	358832	AIRIDE SPRING CTRL VALVE 98
34	1	358839	AIRIDE CTRL LINK KIT, 2100 99
35	2	358990	NYLON GUIDE, 2100 LEG 99
36	1	358991	INNER KEEPER,NYL GUIDE,2100 99
37	1	358992	OUTER KEEPER,NYL GUIDE,2100 99
38	1	358993	NYLON GUIDE BACK PLATE,2100 99
39	2	470118	1/4UNC X 3/4 FLANGE HEX BOLT
40	2	470121	1/4UNC HEX FLANGE LOCK NUT
41	3	900837	5/8UNF X 3 1/2 HEX BOLT GR8
42	2	910002	5/16UNC HEX NUT
43	1	910013	3/4UNF HEX NUT
44	2	914002	5/16UNC HEX STOVER NUT
45	1	920506	3/4 LOCK WASHER
46	1	711016	1/4NPT-90-1/4NYL TUBE FTG BR8
47	2	711023	1/8MNPT-1/4OD NYL TUBE FTGBRS
48	1	601413	HOSE, 1/4 X 8 AIR
49	2	900065	5/16UNC X 1" HEX BOLT
50	1	342638	NYL HOSE SLEEVE,2.96ID X 65.00
51	1	483063	1.65 ID X 2.50 OD X .074T WASH
52	1	342654	NYL HOSE SLEEVE,3.66ID X 24.00

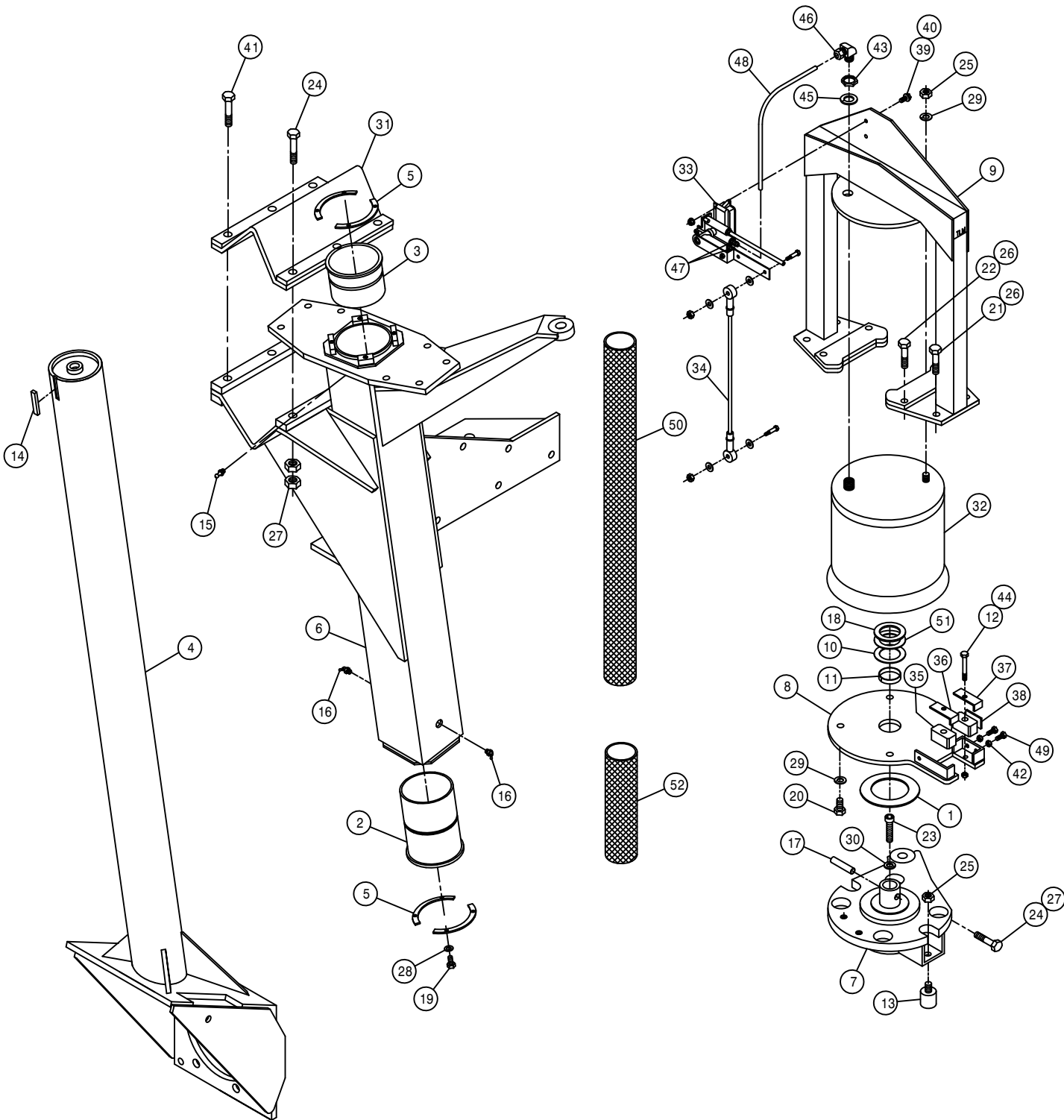

26

225026

RIGHT REAR LEG ASSEMBLY

DET. QTY PART NO. DESCRIPTION

1	1	359017	REAR WHL MTR SHLD WLD,2100 00
2	1	358934	REAR LEG HYD TUBE BRKT,2100 98
3	1	470066	1/2UNC X 1/2 AL HD CUP SET SCR
4	1	470273	TUBE CLAMP BODY, .375- .375- .500
5	1	470275	TUBE CLAMP BODY,1.000-1.000
6	1	470277	CLAMP WELD PLATE, SNGL, 2.15LG
7	1	470278	CLAMP WELD PLATE, SNGL, 2.75LG
8	1	471023	GREASE ZERK 1/4-28 X 45
9	1	610634	ZERK BOLT, 1 1/2, TORQ HUB
10	1	610689	TORQ HUB, 26:1 B-MT MW3BA
11	1	610640	SUND HYD MOTOR, M46-4144
12	1	615708	LWR HYD TUBE ASSY,LEG 2100 98
13	1	615709	UPR HYD TUBE ASSY,LEG 2100 98
14	1	615711	LF/RR HYD DRN TUBE ASSY2100 98
15	1	615713	LF/RR HYD CTRL TUBE ASSY210098
16	1	618119	9/16MJIC-90-9/16MOR LBO
17	2	618178	1 5/16MJIC-90-1 5/16MOR LBO
18	1	618474	3/4MJIC-90-1 1/16MOR LBO
19	1	662256	STALK GUIDE WLD, 2100 2000
20	1	870045	O-RING 4 1/8 OD X 4 ID
21	1	900068	5/16UNC X 1 3/4 HEX BOLT
22	1	900070	5/16UNC X 2 1/2 BOLT
23	2	920004	1/2 SAE FLAT WASHER
24	6	900264	1/2UNC X 1 1/4 HEX BOLT
25	2	900265	1/2UNC X 1 1/2 HEX BOLT
26	1	900266	1/2UNC X 1 3/4 HEX BOLT
27	6	900333	5/8UNC X 1 1/2 HEX BOLT
28	2	914002	5/16UNC HEX STOVER NUT
29	10	914008	1/2UNC HEX STOVER NUT
30	2	920504	1/2 LOCK WASHER
31	6	920505	5/8 LOCK WASHER
32	2	618577	1 5/16MJIC UNION
33	1	618314	3/4MJIC UNION
34	2	619010	9/16MJIC UNION
35	9	470140	5/8UNF HEX SMTH FLANGE NUT PLT
36	1	359022	REAR HYD TUBE MTG PLT,2100 00
37	1	615714	RH HYD BRAKE TUBE ASSY,2100 98
38	1	618114	9/16MJIC-90-7/16MOR LBO
39	1	828093	MICO HYD BRAKE 98
40	2	900271	1/2UNC X 3 1/4 HEX BOLT

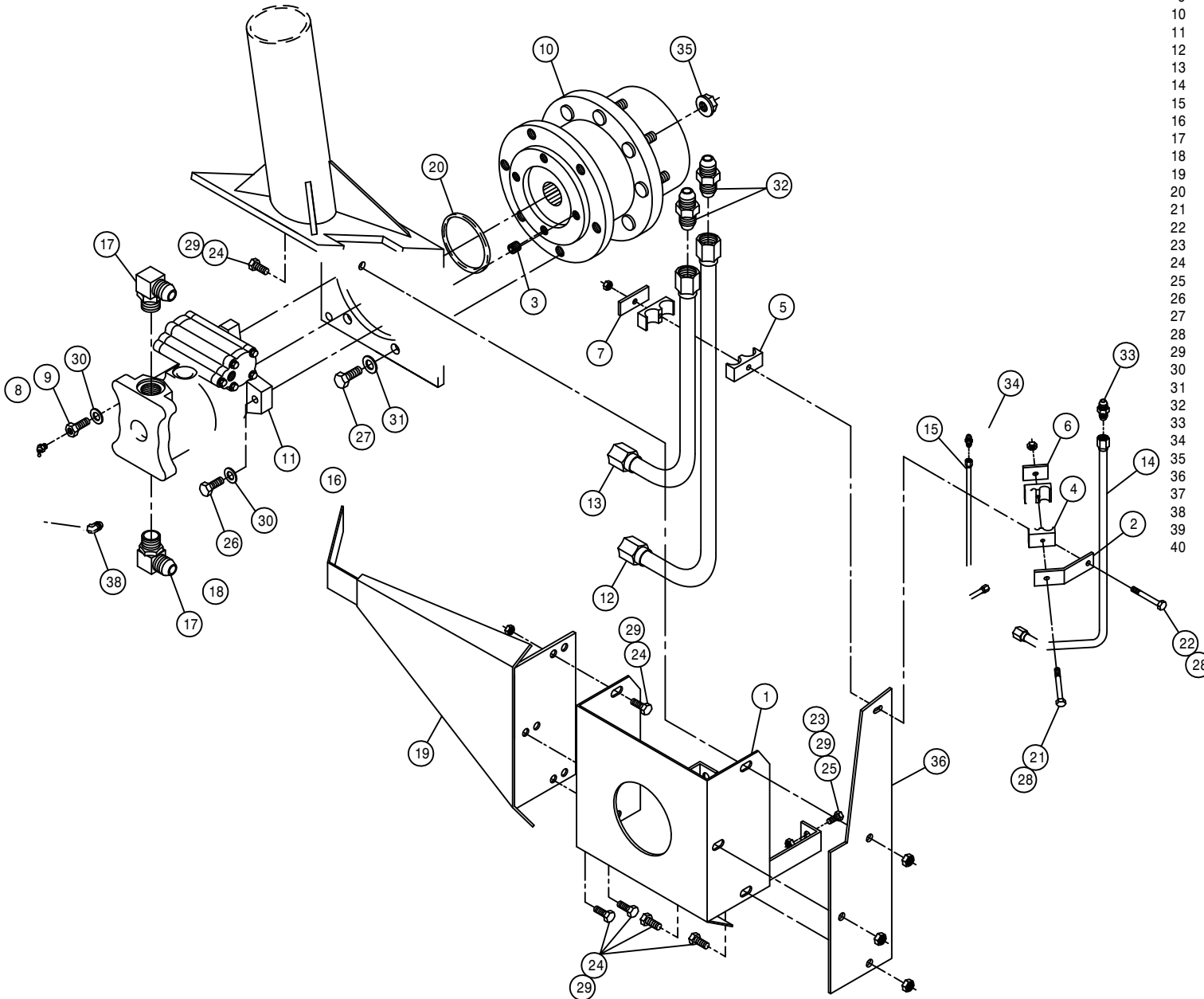

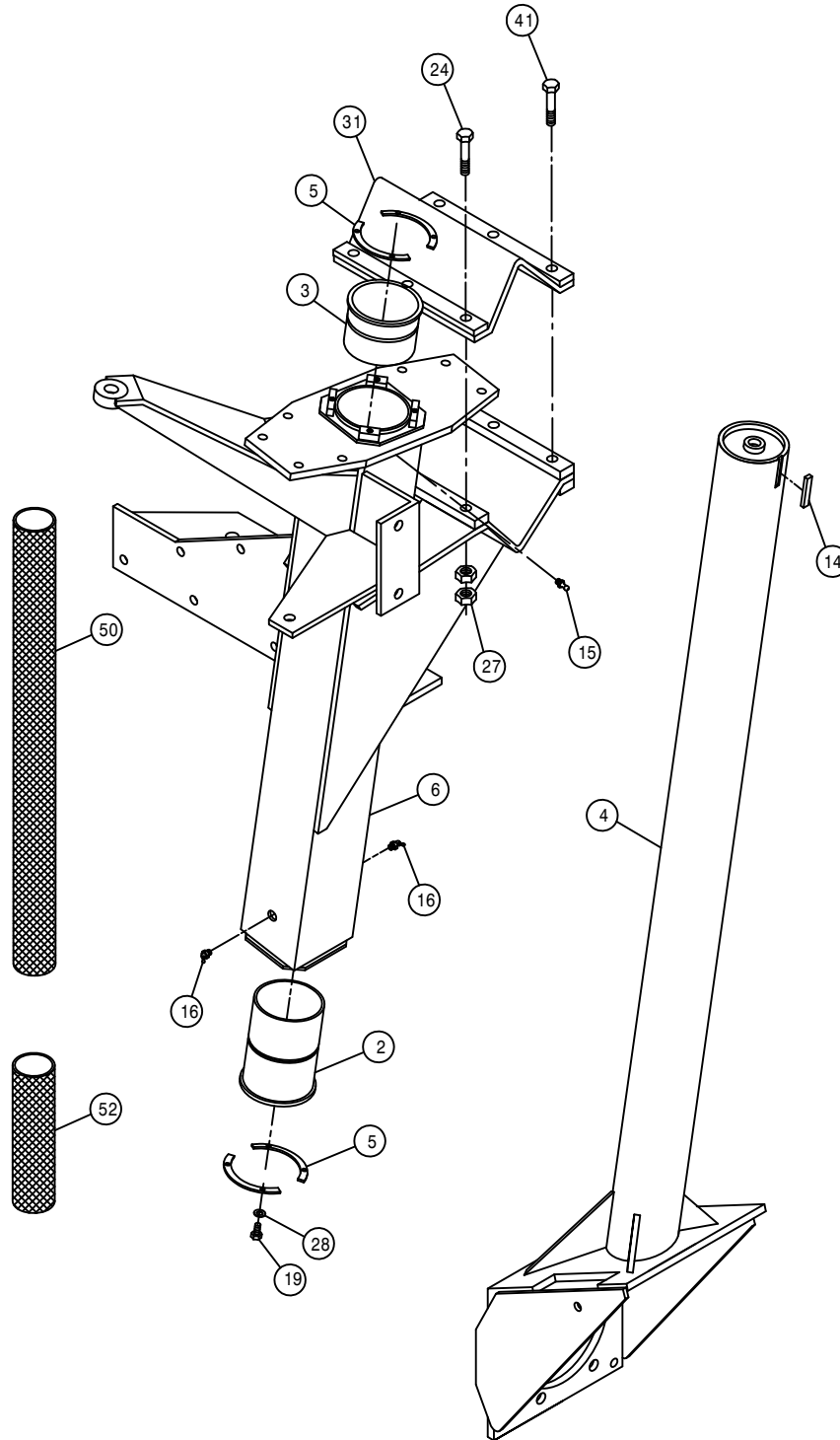
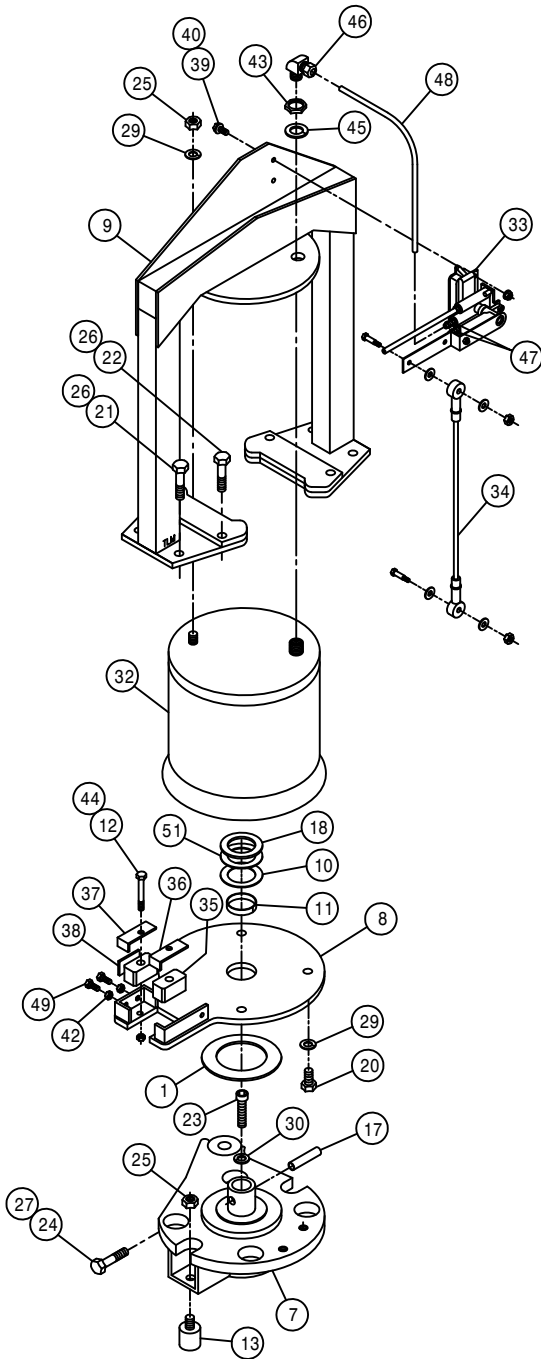

LEFT REAR LEG ASSEMBLY

DET.	QTY	PART NO.	DESCRIPTION
1	1	483062	3.00 ID X 4.62 OD X .125T WASH
2	1	358564	FRT LEG LWR NYL SLEEVE 280 89
3	1	358565	FRT LEG UPR NYL SLEEVE 280 89
4	1	358871	LH REAR INNER LEG WLD, 2100 98
5	4	358927	LWR BRG KPR, LEG 98
6	1	358957	LH REAR OUTER LEG WLD, 2100 99
7	1	358971	STEERING ARM WLD, RF/LR 2100 99
8	1	358980	AIR BAG MT WLD, RF/LR 2100 99
9	1	358985	AIR BAG ARCH WLD, RF/LR 2100 99
10	1	358994	LEG WASHER, NYLON 2100 99
11	1	358995	NYLON BEARING, LWR AB MT 2100 99
12	2	900069	5/16UNC X 2" HEX BOLT
13	2	470259	URETHANE BUMPER, 1.25D X 1.25L
14	1	470265	KEY, .250 X .375 X 1.88 LG
15	1	471005	1/4 28 X 1/2 GREASE ZERK
16	2	471023	GREASE ZERK 1/4-28 X 45
17	1	473906	SPIRAL PIN, 1/2 X 2 1/2 LG
18	1	483061	1.65 ID X 2.50 OD X .188T WASH
19	8	900064	5/16UNC X 3/4 HEX BOLT
20	4	900264	1/2UNC X 1 1/4 HEX BOLT
21	4	900265	1/2UNC X 1 1/2 HEX BOLT
22	4	900266	1/2UNC X 1 3/4 HEX BOLT
23	1	900390	5/8UNC X 2 1/2 SOCKET CAP SCR
24	4	900836	5/8UNF X 3 1/4 HEX BOLT GR8
25	3	910008	1/2UNC HEX NUT
26	8	914008	1/2UNC HEX STOVER NUT
27	14	914811	5/8UNF HEX NUT GR8
28	8	920501	5/16 LOCK WASHER
29	5	920504	1/2 LOCK WASHER
30	1	920505	5/8 LOCK WASHER
31	1	358759	LEG MT V-PLT WLD, 284T 94
32	1	358831	AIRIDE SPRING 98
33	1	358832	AIRIDE SPRING CTRL VALVE 98
34	1	358839	AIRIDE CTRL LINK KIT, 2100 99
35	2	358990	NYLON GUIDE, 2100 LEG 99
36	1	358991	INNER KEEPER, NYL GUIDE, 2100 99
37	1	358992	OUTER KEEPER, NYL GUIDE, 2100 99
38	1	358993	NYLON GUIDE BACK PLATE, 2100 99
39	2	470118	1/4UNC X 3/4 FLANGE HEX BOLT
40	2	470121	1/4UNC HEX FLANGE LOCK NUT
41	3	900837	5/8UNF X 3 1/2 HEX BOLT GR8
42	2	910002	5/16UNC HEX NUT
43	1	910013	3/4UNF HEX NUT
44	2	914002	5/16UNC HEX STOVER NUT
45	1	920506	3/4 LOCK WASHER
46	1	711016	1/4NPT-90-1/4NYL TUBE FTG BR8
47	2	711023	1/8MNPT-1/4OD NYL TUBE FTG BR8
48	1	601413	HOSE, 1/4 X 8 AIR
49	2	900065	5/16UNC X 1" HEX BOLT
50	1	342638	NYL HOSE SLEEVE, 2.96ID X 65.00
51	1	483063	1.65 ID X 2.50 OD X .074T WASH
52	1	342654	NYL HOSE SLEEVE, 3.66ID X 24.00

LEFT REAR LEG ASSEMBLY

DET.	QTY	PART NO.	DESCRIPTION
1	1	359017	REAR WHL MTR SHLD WLD,2100 00
2	1	358934	REAR LEG HYD TUBE BRKT,2100 98
3	1	470066	1/2UNC X 1/2 AL HD CUP SET SCR
4	1	470273	TUBE CLAMP BODY, .375-.375-.500
5	1	470275	TUBE CLAMP BODY,1.000-1.000
6	1	470277	CLAMP WELD PLATE, SNGL, 2.15LG
7	1	470278	CLAMP WELD PLATE, SNGL, 2.75LG
8	1	471023	GREASE ZERK 1/4-28 X 45
9	1	610634	ZERK BOLT, 1 1/2, TORQ HUB
10	1	610689	TORQ HUB, 26:1 B-MT MW3BA
11	1	610643	SUND HYD MOTOR, M46-4199 W/SEN
12	1	615708	LWR HYD TUBE ASSY,LEG 2100 98
13	1	615709	UPR HYD TUBE ASSY,LEG 2100 98
14	1	615710	RF/LR HYD DRN TUBE ASSY2100 98
15	1	615712	RF/LR HYD CTRL TUBE ASSY210098
16	1	618119	9/16MJIC-90-9/16MOR LBO
17	2	618178	1 5/16MJIC-90-1 5/16MOR LBO
18	1	618474	3/4MJIC-90-1 1/16MOR LBO
19	1	662256	STALK GUIDE WLD, 2100 2000
20	1	870045	O-RING 4 1/8 OD X 4 ID
21	1	900068	5/16UNC X 1 3/4 HEX BOLT
22	1	900070	5/16UNC X 2 1/2 BOLT
23	2	920004	1/2 SAE FLAT WASHER
24	6	900264	1/2UNC X 1 1/4 HEX BOLT
25	2	900265	1/2UNC X 1 1/2 HEX BOLT
26	1	900266	1/2UNC X 1 3/4 HEX BOLT
27	6	900333	5/8UNC X 1 1/2 HEX BOLT
28	2	914002	5/16UNC HEX STOVER NUT
29	10	914008	1/2UNC HEX STOVER NUT
30	2	920504	1/2 LOCK WASHER
31	6	920505	5/8 LOCK WASHER
32	2	618577	1 5/16MJIC UNION
33	1	618314	3/4MJIC UNION
34	2	619010	9/16MJIC UNION
35	9	470140	5/8UNF HEX SMTH FLANGE NUT PLT
36	1	359022	REAR HYD TUBE MTG PLT,2100 00
37	1	615715	LH HYD BRAKE TUBE ASSY,2100 98
38	1	618114	9/16MJIC-90-7/16MOR LBO
39	1	828093	MICO HYD BRAKE 98
40	2	900271	1/2UNC X 3 1/4 HEX BOLT
41	1	610625	SENSOR,WHL MOTOR 610621/610671

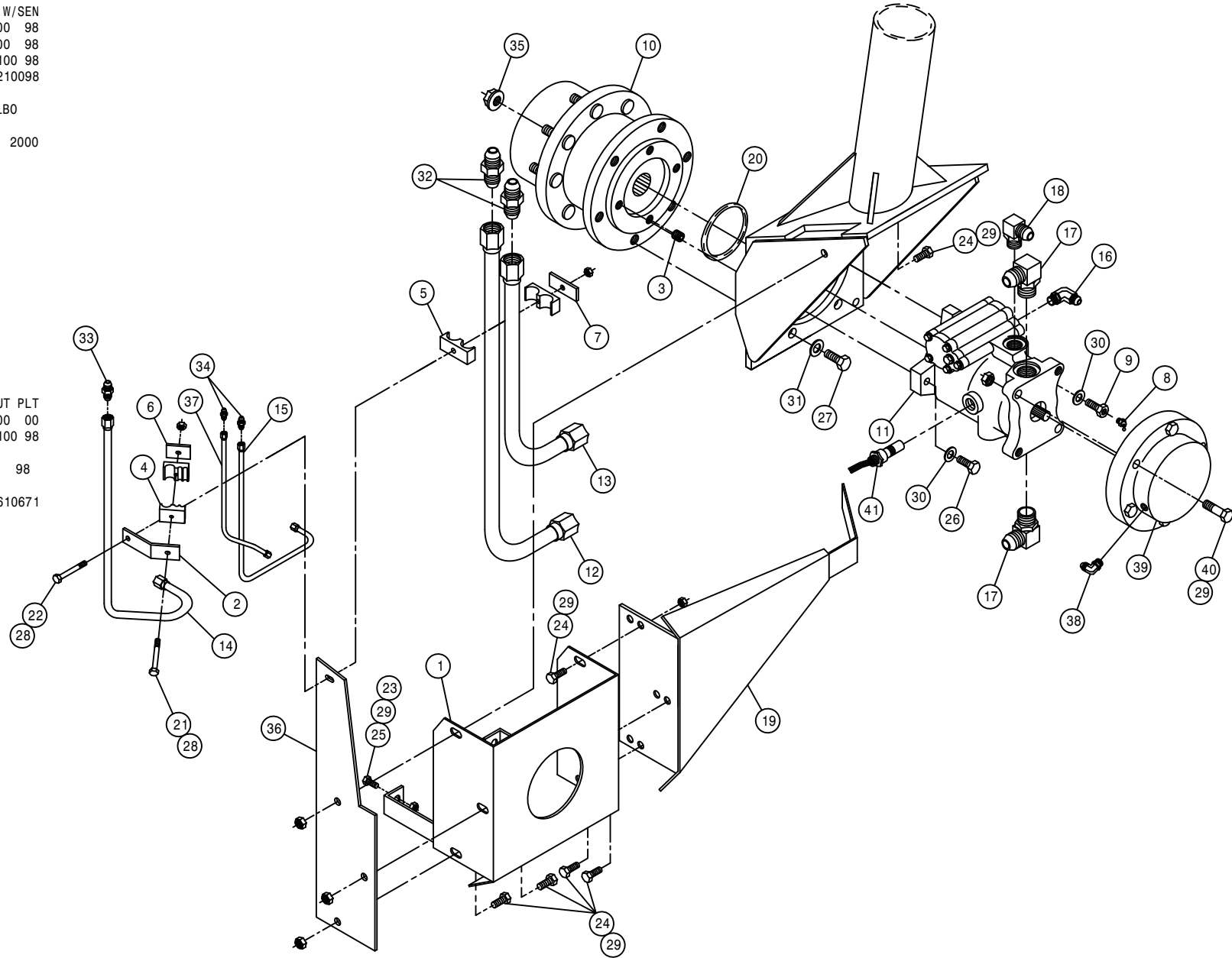

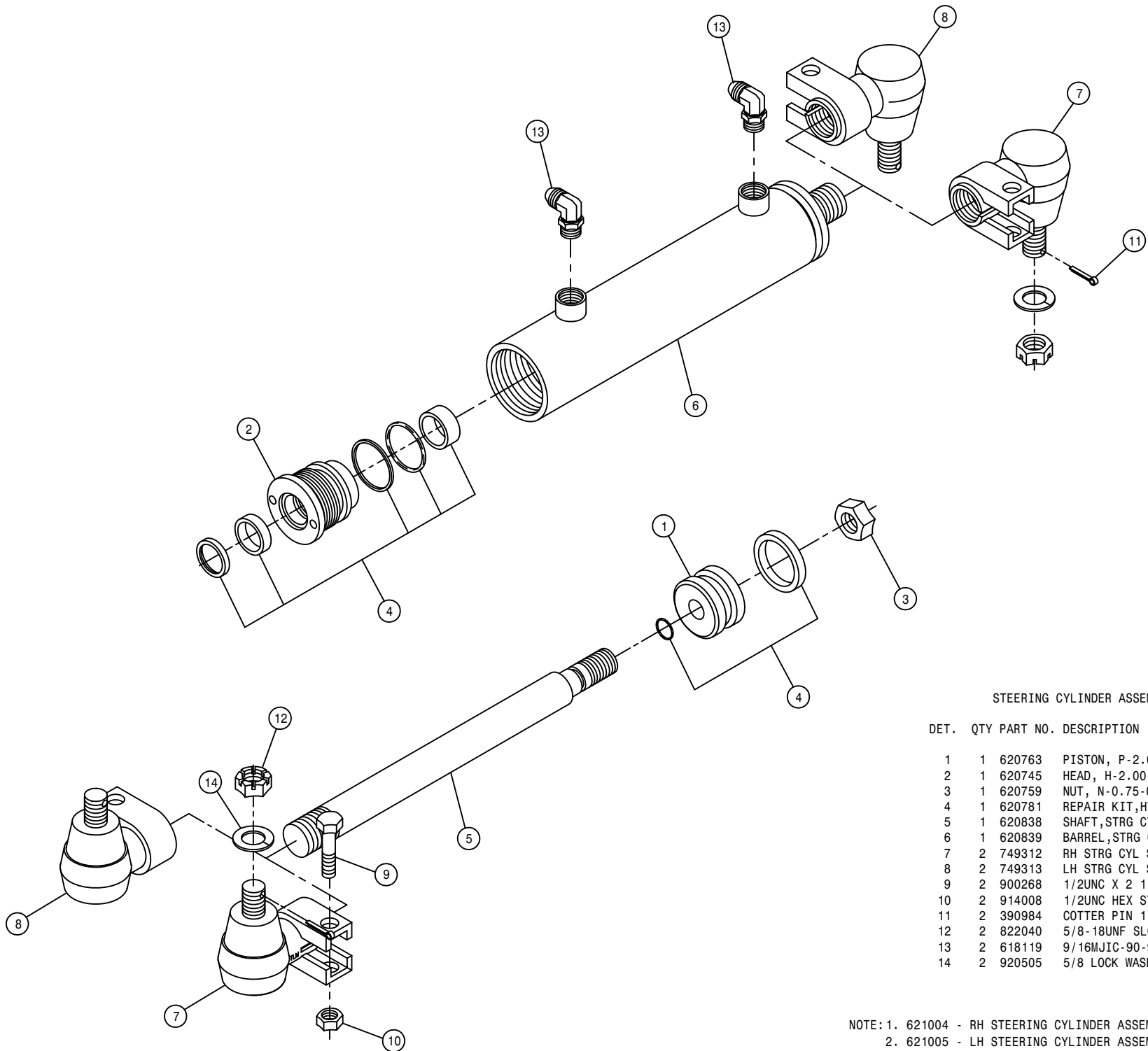

STEERING CYLINDER ASSEMBLY

DET. QTY PART NO. DESCRIPTION

DET.	QTY	PART NO.	DESCRIPTION
1	1	620763	PISTON, P-2.00-107
2	1	620745	HEAD, H-2.00-335
3	1	620759	NUT, N-0.75-01
4	1	620781	REPAIR KIT, HYD CYL, RK-2.00-803
5	1	620838	SHAFT, STRG CYL, 2100 620835
6	1	620839	BARREL, STRG CYL, 2100 620835
7	2	749312	RH STRG CYL SWIV ASSY
8	2	749313	LH STRG CYL SWIV ASSY
9	2	900268	1/2UNC X 2 1/2 HEX BOLT
10	2	914008	1/2UNC HEX STOVER NUT
11	2	390984	COTTER PIN 1/8 X 1 1/4
12	2	822040	5/8-18UNF SLOTTED HEX NUT
13	2	618119	9/16MJIC-90-9/16MOR LBO
14	2	920505	5/8 LOCK WASHER

NOTE: 1. 621004 - RH STEERING CYLINDER ASSEMBLY W/CYL SWIV DET.7  
 2. 621005 - LH STEERING CYLINDER ASSEMBLY W/CYL SWIV DET.8  
 3. 620835 - STEERING CYLINDER ASSEMBLY W/O CYL SWIV INCLUDES ITEMS 1-6

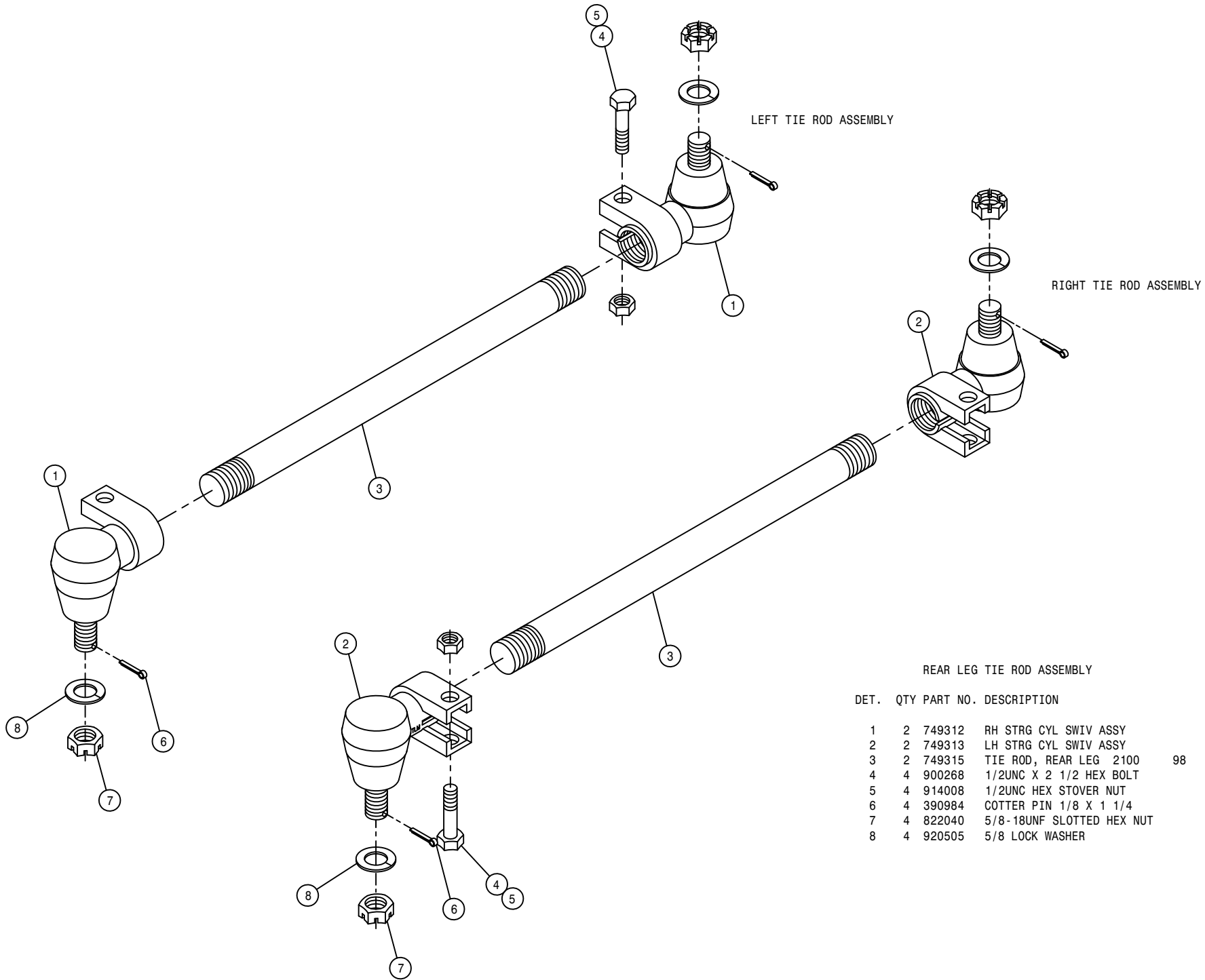

DET.	QTY	PART NO.	DESCRIPTION	
1	2	749312	RH STRG CYL SWIV ASSY	
2	2	749313	LH STRG CYL SWIV ASSY	
3	2	749315	TIE ROD, REAR LEG 2100	98
4	4	900268	1/2UNC X 2 1/2 HEX BOLT	
5	4	914008	1/2UNC HEX STOVER NUT	
6	4	390984	COTTER PIN 1/8 X 1 1/4	
7	4	822040	5/8-18UNF SLOTTED HEX NUT	
8	4	920505	5/8 LOCK WASHER	

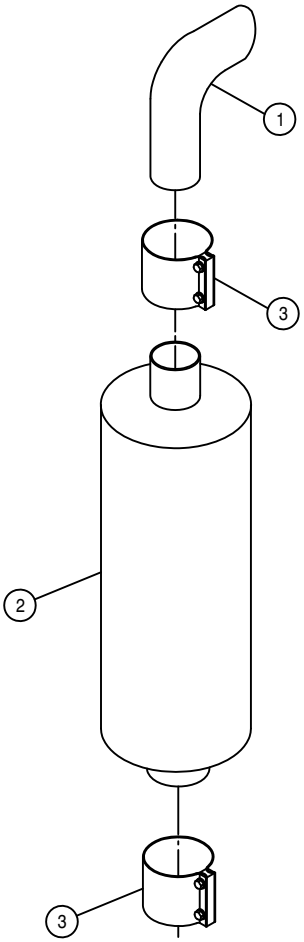

MUFFLER ASSEMBLY

DET.	QTY	PART NO.	DESCRIPTION	
1	1	316300	3" EXHAUST STACK	97
2	1	316326	MUFFLER, 2100	98
3	2	470243	3" STRAP BAND EXHAUST CLAMP	



AIR CLEANER ASSEMBLY

DET. QTY PART NO. DESCRIPTION

DET.	QTY	PART NO.	DESCRIPTION
1	1	314970	AIR CLEANER, 510 CFM
2	1	314971	AIR CLEANER HOOD FOR 314970
3	2	314972	AIR CLEANER MT BAND FOR314970
4	1	314986	AIR CLEANER HOOD EXTEN,5"X8"LG
5	1	314973	AIR CLEANER ELEMENT FOR314970
6	1	316297	5"-4" 90DEG REDU ELBOW,RUBBER
7	1	316344	4" X 4.00" AIR INTAKE TUBE 98
8	1	316324	4" X 29" AIR INTAKE TUBE, 98
9	2	316325	4.00 90DEG ELBOW, 2100 98
10	4	470113	5/16UNC HEX FLANGE LOCK NUT
11	4	470233	5/16UNC X 3/4 FLANGE HEX BOLT
12	1	470260	MUFFLER CLAMP, 5.00
13	5	520134	4.31/4.59 T-BOLT HOSE CLAMP SS
14	1	520136	5.31/5.59 T-BOLT HOSE CLAMP SS

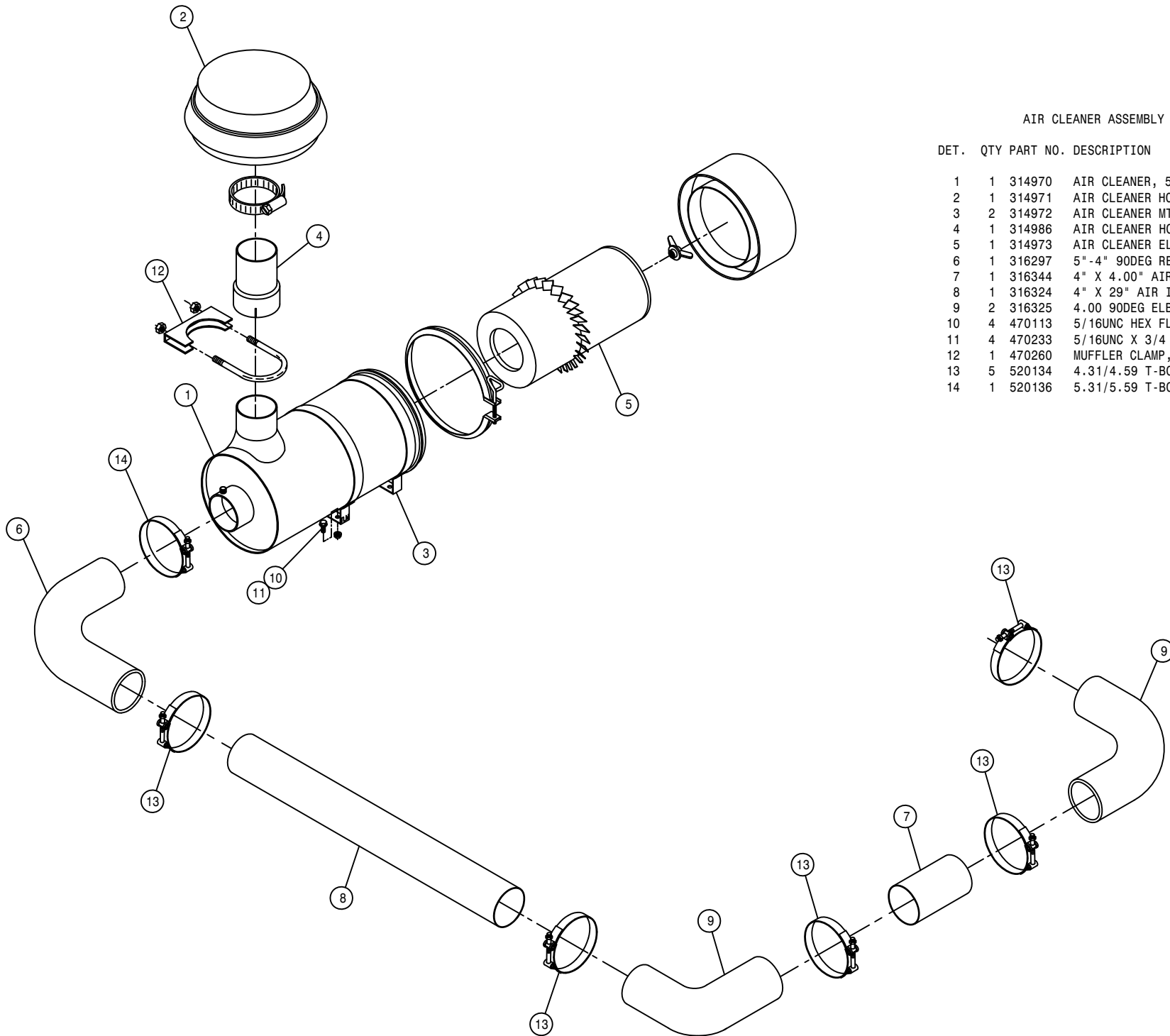

CAB ASSEMBLY

DET.	QTY	PART NO.	DESCRIPTION	
1	38	193044	WINDOW WEATHERSTRIP	94
2	38	193045	LOCK STRIP FOR 193044	94
3	18	193050	TRIM-LOCK SEAL, 250'	
4	1	200019	.25 SCH 40BP X 1.00 LG	C/L
5	1	202037	WINDSHIELD WIPER SPACER	
6	1	290412	DIMMER SWITCH	
7	1	290417	18" WIPER BLADE	
8	6	291603	HALOGEN WORKLAMP, SIDE MT 12V	
9	1	342357	CAB WELD, 2100	98
10	1	342403	CAB ROOF WLD, 2100	98
11	1	342414	REAR CAB ROOF MT WLD, 2100	98
12	2	342416	CAB ROOF 4" LINKAGE, 2100	98
13	2	342417	CAB ROOF 8" LINKAGE, 2100	98
14	1	342418	CAB ROOF PROP, 2100	98
15	1	342419	CAB ROOF PROP MT, 2100	
16	1	342420	HEAD LINER ANGLE, RH, 2100	98
17	1	342642	SOLU SWITCH ADPTR BRKT, 2100	98
18	3	470067	RUBBER GROMMET 1/4 ID	
19	2	470070	RUBBER GROMMET 3/8 ID	
20	6	470100	3/8 INT TOOTH LOCK WASHER	
21	2	470175	10-32 HEX FLANGE LOCK NUT	
22	1	470222	GRAB HANDLE, BLACK MOULDED	
23	1	470229	IDENTIFICATION TIE, WHITE	
24	4	470261	3/8UNC NUT, U-TAPPED SPRING	
25	4	470262	3/8 X 1" BONDED SEALING WASH	
26	16	472349	1/4 X 3/4 20THD-IN TEK TYPE	
27	6	473779	10MM-1.50 HEX NUT	
28	2	650524	OUTSIDE REAR VIEW MIRROR	
29	1	658008	WINDSHIELD WIPER MOTOR	
30	1	658013	WIPER ARM	
31	1	658022	FRONT CAB GLASS, 2100	98
32	1	658023	SIDE CAB GLASS, 2100	98
33	1	658024	REAR CAB GLASS, 2100	98
34	2	903708	1/4UNC X1/2 PHIL PNHD MACHSCR	
35	2	900003	1/4UNC X 1" HEX BOLT	
36	1	900005	1/4UNC X 1 1/2 HEX BOLT	
37	4	900129	3/8UNC X 1" HEX BOLT	
38	4	900263	1/2UNC X 1" HEX BOLT	
39	3	914000	1/4UNC HEX STOVER NUT	
40	8	914008	1/2UNC HEX STOVER NUT	
41	1	290107	GROUND CABLE, 8" X 4GA .406LUGS	
42	2	470087	3/8UNC HEX FLANGE LOCK NUT	
43	1	900128	3/8UNC X 3/4 HEX BOLT	
44	4	311051	RUBBER MOUNT, RB3-350	
45	4	311052	SNUBBING WASHER FOR 311051	
46	4	900829	5/8UNC X 4" HEX BOLT GR8	
47	4	914010	5/8UNC HEX STOVER NUT	
48	1	290003	WINDSHIELD WASHER NOZZLE KIT	
49	1	291569	3/8 X 6" HEAT SHRINK TUBE	
50	2	903883	10-32 X 1/2 SLT RDHD MACH SCR	
51	2	659704	FOAM, 2" THK X 2" WIDE X 42" LG	
52	2	470086	1/4UNC NUTSERT .020-.100MATL	

34

225034

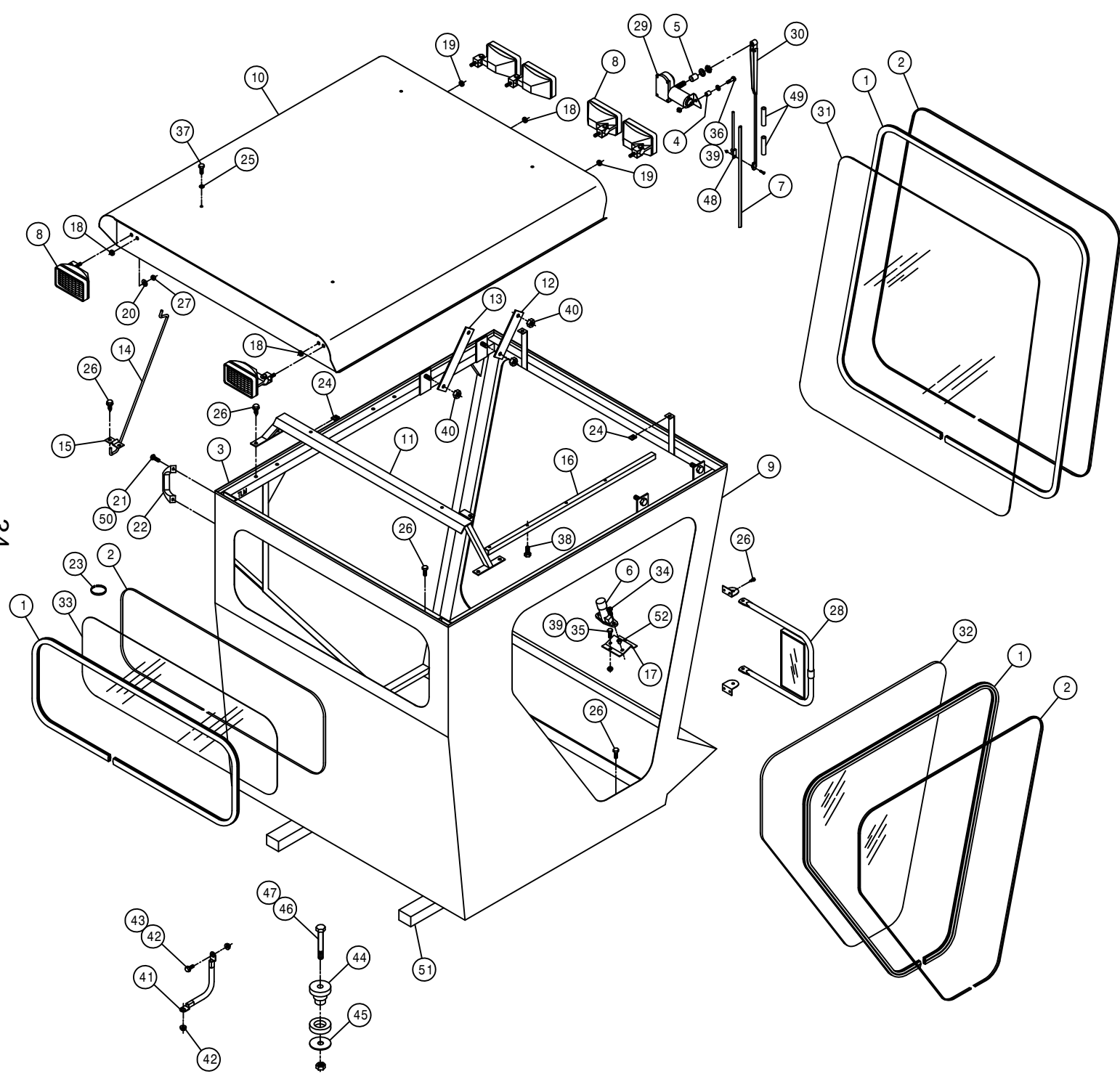

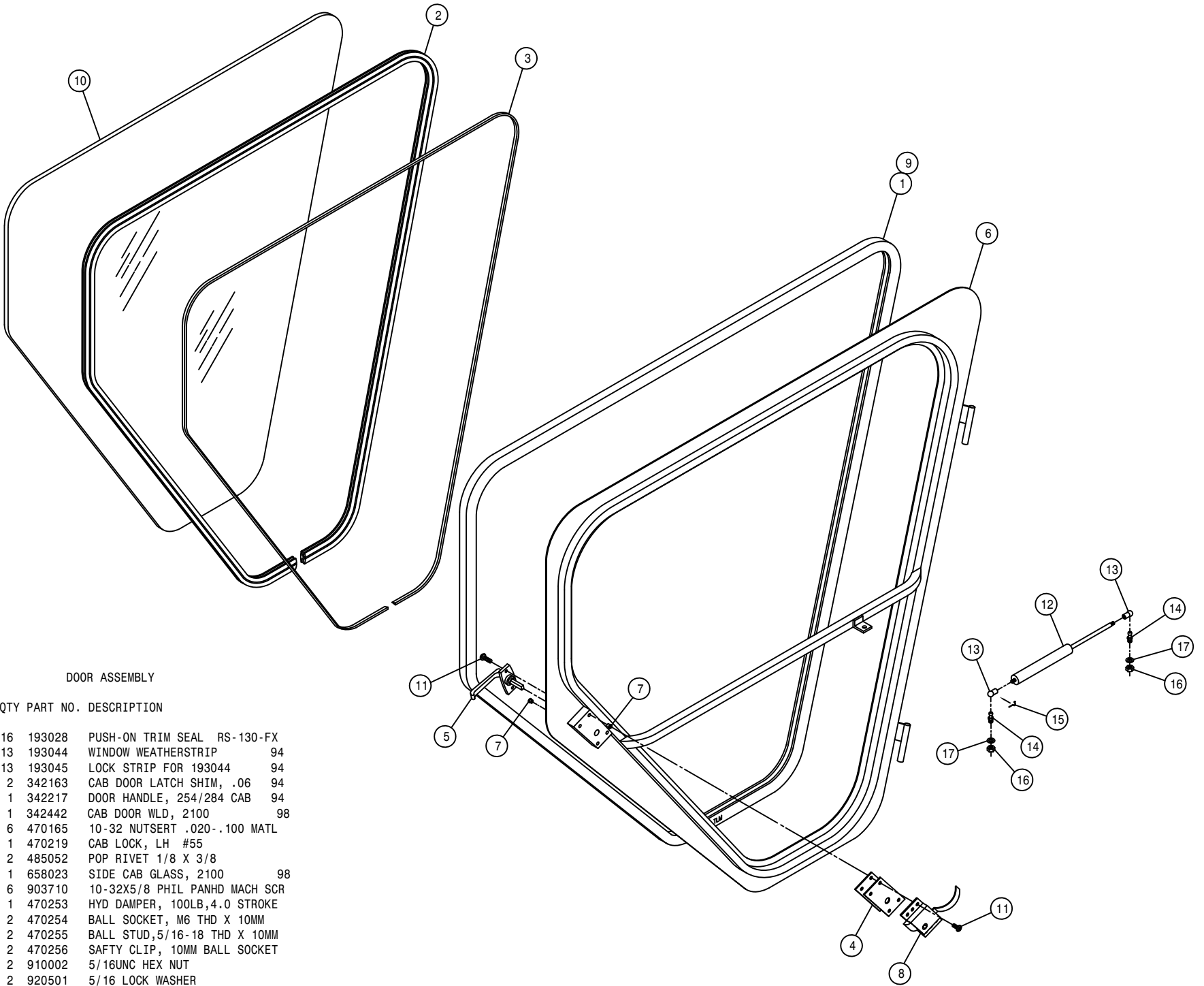

DOOR ASSEMBLY

DET. QTY PART NO. DESCRIPTION

1	16	193028	PUSH-ON TRIM SEAL RS-130-FX
2	13	193044	WINDOW WEATHERSTRIP 94
3	13	193045	LOCK STRIP FOR 193044 94
4	2	342163	CAB DOOR LATCH SHIM, .06 94
5	1	342217	DOOR HANDLE, 254/284 CAB 94
6	1	342442	CAB DOOR WLD, 2100 98
7	6	470165	10-32 NUTSERT .020-.100 MATL
8	1	470219	CAB LOCK, LH #55
9	2	485052	POP RIVET 1/8 X 3/8
10	1	658023	SIDE CAB GLASS, 2100 98
11	6	903710	10-32X5/8 PHIL PANHD MACH SCR
12	1	470253	HYD DAMPER, 100LB, 4.0 STROKE
13	2	470254	BALL SOCKET, M6 THD X 10MM
14	2	470255	BALL STUD, 5/16-18 THD X 10MM
15	2	470256	SAFTY CLIP, 10MM BALL SOCKET
16	2	910002	5/16UNC HEX NUT
17	2	920501	5/16 LOCK WASHER

AIR CONDITIONER ASSEMBLY

DET.	QTY	PART NO.	DESCRIPTION	
1	1	291212	RADIO	94
2	1	291214	ANTENNA	94
3	2	291219	SPEAKER, 5 1/4"RD	
4	2	291224	SPEAKER GRILLE, 6" BLACK MESH	
5	1	291605	INTERIOR LIGHT W/SWITCH	
6	1	291606	ROTARY HEADLAMP SWITCH	
7	1	291607	SWITCH KNOB FOR 291606	
8	1	291622	SWITCH, 1P ON/OFF	511-003
9	1	291630	LENS, WINDSHIELD WASHER	
10	1	291631	LENS, HAZARD	
11	1	291678	SWITCH, 511-115	
12	2	293246	END BEZEL	
13	10	903710	10-32X5/8 PHIL PANHD MACH SCR	
14	1	903883	10-32 X 1/2 SLT RDHD MACH SCR	
15	1	342411	REAR A/C BLWR MT WLD, 2100	98
16	1	342421	LIGHT SWITCH PANEL, 2100	98
17	1	342633	LIGHT SWITCH PANEL KPR,2100	98
18	1	470067	GROMMET, .250ID .125GW .375GD	
19	4	470087	3/8UNC HEX FLANGE LOCK NUT	
20	1	470175	10-32 HEX FLANGE LOCK NUT	
21	8	472349	1/4 X 3/4 20THD-IN TEK TYPE	
22	24	473966	6X3/4 PHIL FLT HD SHT MTL SCR	
23	2	520055	HOSE CLAMP NO 12 STAINLESS	
24	1	601342	HOSE, 5/8 X 192 HEATER	
25	1	601431	HOSE, 5/8 X 250 HEATER	
26	1	657400	A/C & HTR ASSY, CAB	R134A
27	1	657401	A/C HOSE KIT, EVAP	R134A
28	1	658317	HEADLINER, 2100	98
29	1	658318	ROOF SEAL, AIR COND	2100
30	4	900128	3/8UNC X 3/4 HEX BOLT	
31	10	914027	10-32 HEX STOVER NUT	
32	1	657418	A/C HOSE ASSY, 5/16 X 198	
33	1	657419	A/C HOSE ASSY, 1/2 X 198	
34	1	657404	A/C BLOWER MOTOR, 12V	MCC
35	2	657405	A/C BLOWER WHEEL W/CLIP	
36	1	657406	A/C EVAPORATOR COIL	
37	1	657407	A/C HEATER COIL	
38	1	657408	A/C THERMOSTAT	
39	2	657409	A/C CONTROL KNOB	
40	1	657410	A/C SWITCH, PUSH ON-OFF	
41	1	657411	A/C EXPANSION VALVE	
42	1	657412	A/C HEATER VALVE, MOTORIZED	
43	1	657413	A/C FILTER, RECIRCULATION	
44	1	657414	A/C BLOWER DRIVE ASSY	
45	2	657415	A/C POTENTIOMETER ASSY	
46	1	657420	A/C VALVE MODULE ASSY	
47	1	657424	A/C AIR FILTER	
48	1	657425	A/C CHARCOAL AIR FILTER	
49	1	903844	8-32 X 1/2 SLT RD HD MACH SCR	
50	2	500098	1/2HB-90-1/2 HOSE BARB, POLY	
51	2	342669	A/C DRAIN HOSE KEEPER	

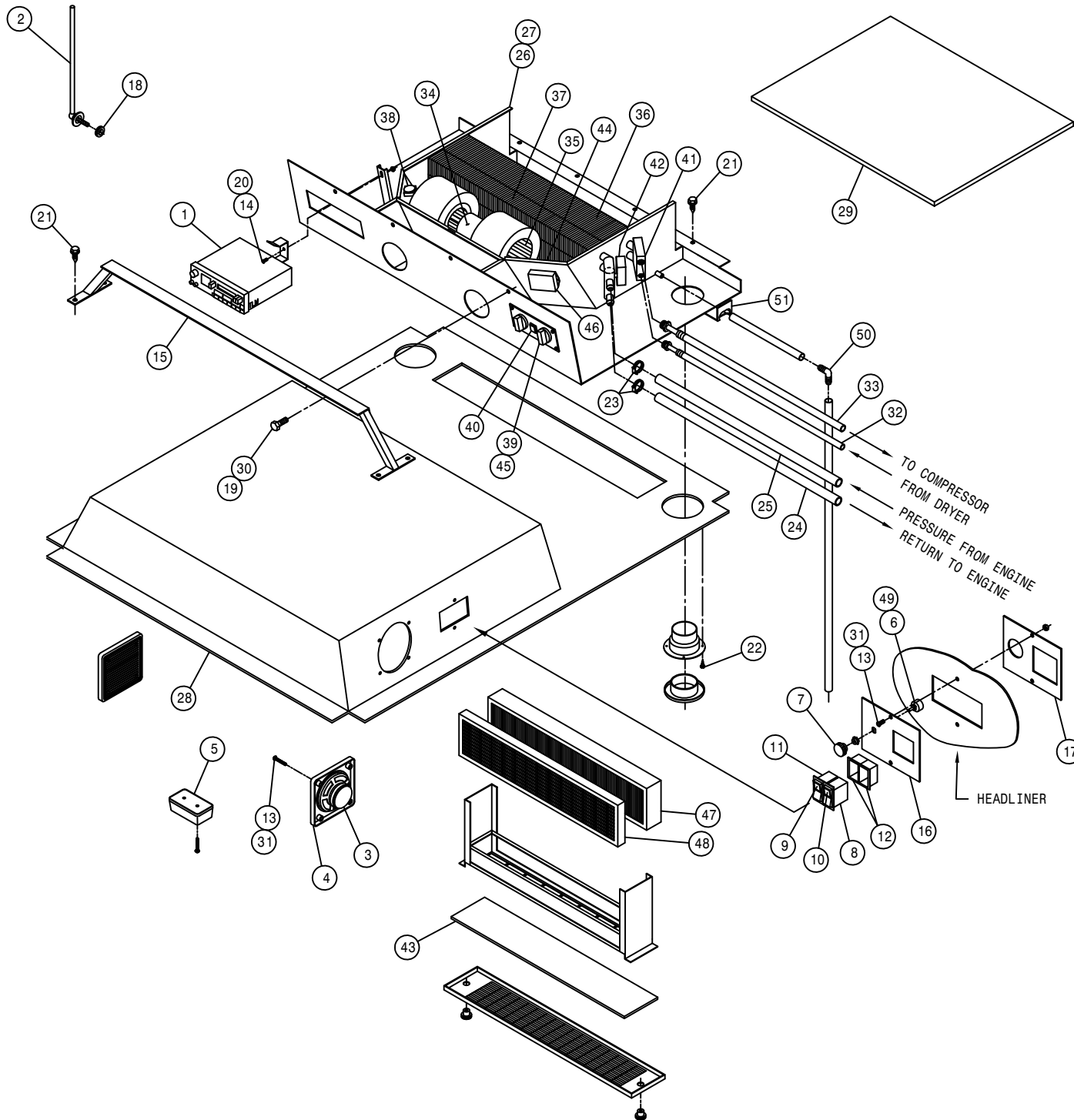

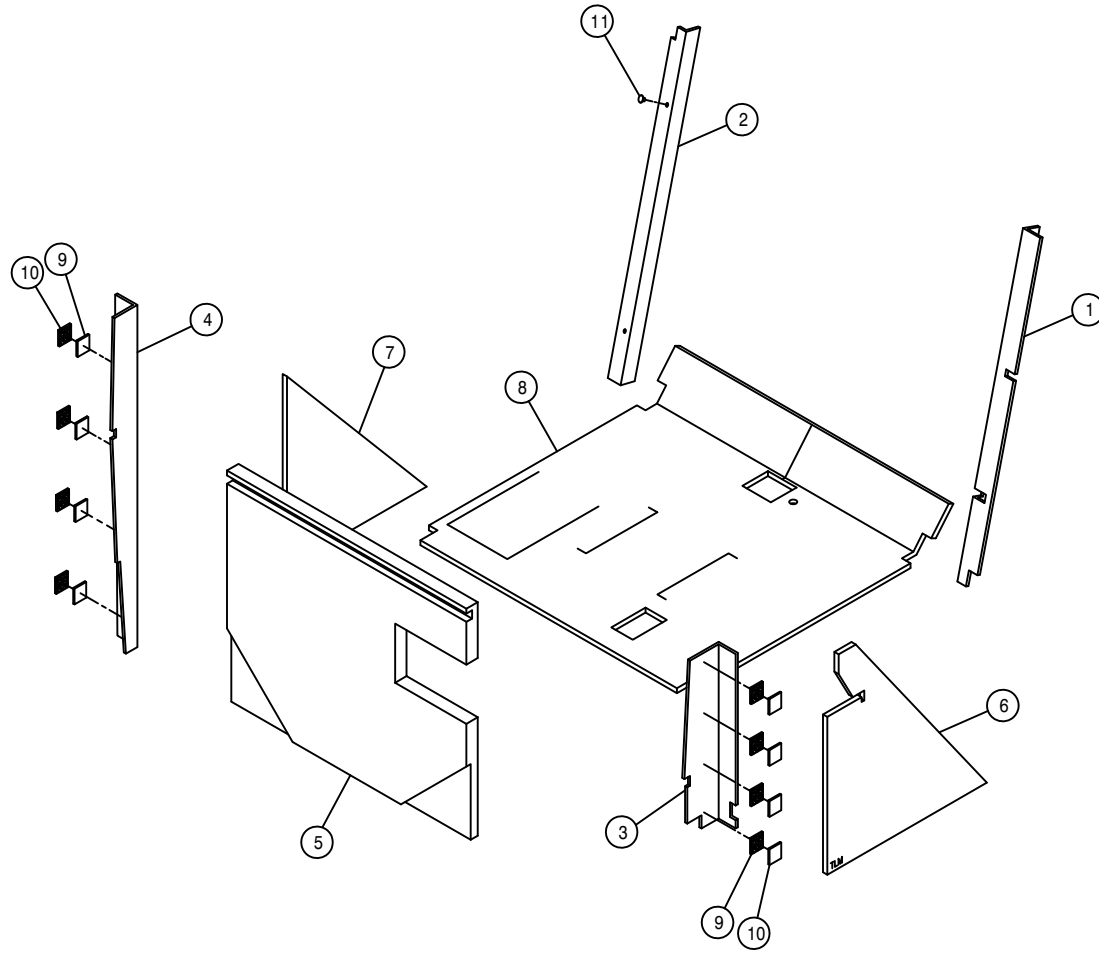

FOAM

DET.	QTY	PART NO.	DESCRIPTION
1	1	658319	POST COVER, RH FRONT
2	1	658320	POST COVER, LH FRONT 2100 98
3	1	658321	POST COVER, RH REAR 2100 98
4	1	658322	POST COVER, LH REAR 2100 98
5	1	658323	BACKPANEL, 2100 98
6	1	658324	SIDE PANEL, RH 2100 98
7	1	658325	SIDE PANEL, LH 2100 98
8	1	658326	FLOORMAT, 2100 98
9	8	471101	DUAL LOCK, 1.00 X 1.00 SJ3542
10	8	471100	DUAL LOCK, 1.00 X 1.00 SJ3541
11	2	470225	TRIM CLIP, 11/16 BLK NYL HEAD

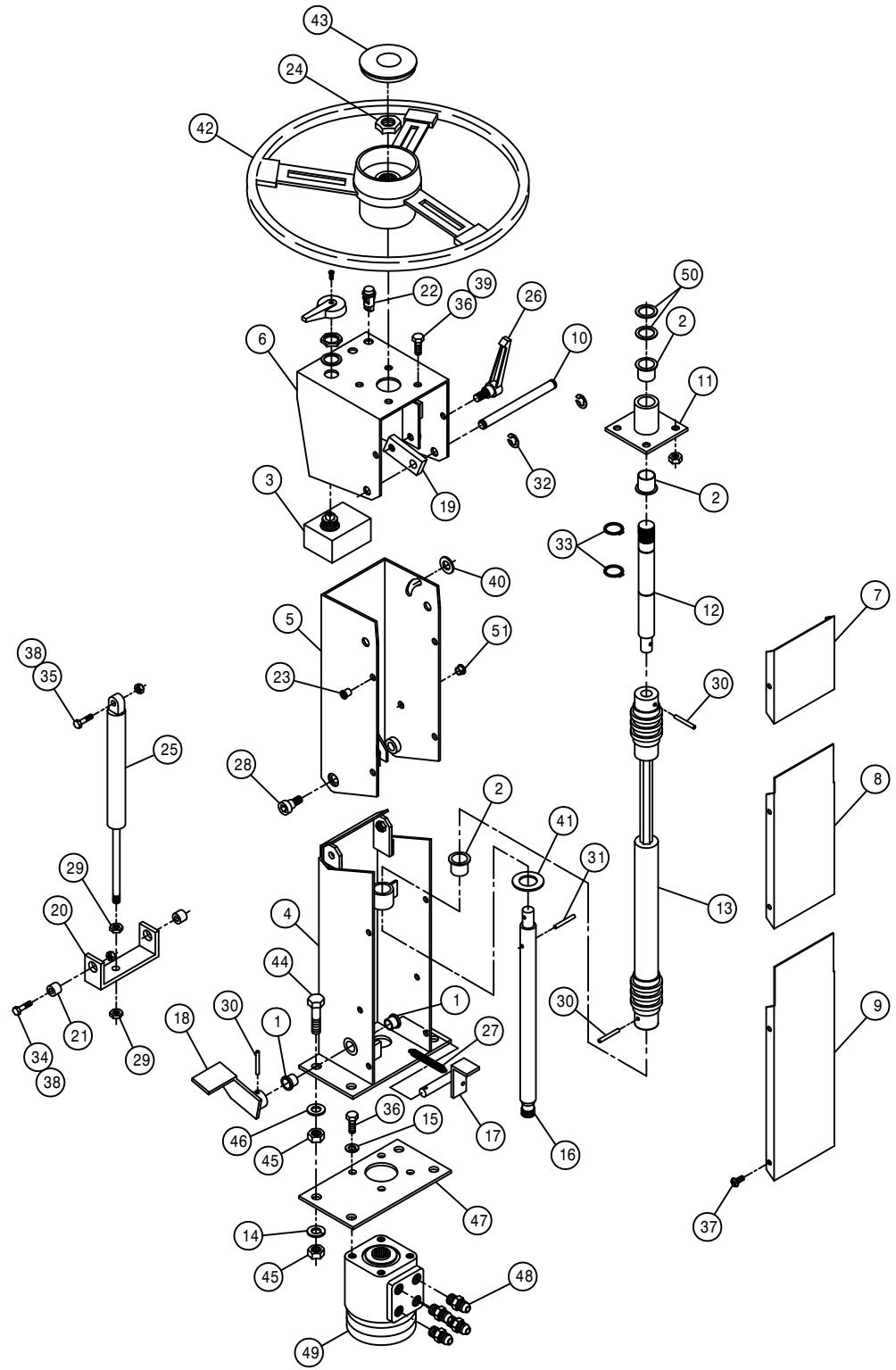

STEERING POST ASSEMBLY

DET.	QTY	PART NO.	DESCRIPTION
	1	2	127502 NYLON FLANGE BRG
	2	3	127503 NYLINER FLG BRG, .875 ID
	3	1	291088 FLASHER / TURN SIGNAL SWITCH
	4	1	342450 LWR STRG COLUMN WLD, 2100 98
	5	1	342454 UPPER STRG COLUMN WLD, 2100 98
	6	1	342461 STRG WHL MT WLD, 2100 98
	7	1	342467 UPPER STRG COLUMN COVER, 2100 98
	8	1	342468 CNTR STRG COLUMN COVER, 2100 98
	9	1	342469 LWR STRG COLUMN SHLD
	10	1	342470 STRG COLUMN PIVOT PIN, 2100 98
	11	1	342471 STRG COL BRG HSG WLD, 2100 98
	12	1	342474 UPPER STEERING SHAFT, 2100 98
	13	1	470285 DOUBLE UNIVERSAL JOINT DRIVER
	14	4	920504 1/2 LOCK WASHER
	15	4	920502 3/8 LOCK WASHER
	16	1	342483 LWR STEERING SHAFT, 2100 98
	17	1	342484 FOOT PEDAL PIV PIN WLD, 2100 98
	18	1	342487 FOOT PEDAL WLD, 2100 98
	19	1	342490 STRG PIVOT LOCK, 2100 98
	20	1	342491 LWR AIR SHOCK PIVOT, 2100 98
	21	2	342492 LWR AIR SHOCK PIV BUSH, 2100 98
	22	2	390318 INDICATOR LIGHT, RED
	23	10	470086 1/4UNC NUTSERT .020-.100MATL
	24	1	470157 13/16-20UNEF HEX NUT STRG WHL
	25	1	470252 GAS SPRING, LOCKING 0350N
	26	1	470257 ADJ HANDLE, 3/8-16 STUD, BLACK
	27	1	470268 SPRING, EXTENSION, .50 X 1.75
	28	2	470283 3/8UNC 1/2 SCKT SHLDR BOLT
	29	2	473830 10MM-1.00 HEX JAM NUT
	30	3	473928 ROLL PIN, 3/16 X 1
	31	1	473936 ROLL PIN, 3/16 X 1 1/4
	32	2	629525 RING, RETAINING, .50DIA SHAFT
	33	2	629533 SNAP RING, 7/8 EXTRN
	34	2	900065 5/16UNC X 1" HEX BOLT
	35	1	900067 5/16UNC X 1 1/2 HEX BOLT
	36	8	900128 3/8UNC X 3/4 HEX BOLT
	37	10	903708 1/4UNC X 1/2 PHIL PNHD MACHSCRL
	38	3	914002 5/16UNC HEX STOVER NUT
	39	4	914004 3/8UNC HEX STOVER NUT
	40	1	920002 3/8 SAE FLAT WASHER
	41	1	920007 7/8 SAE FLAT WASHER
	42	1	749294 STEERING WHEEL, VIP 14"
	43	1	749295 STRG WHL CAP W/HAGIE EMBLEM
	44	4	900267 1/2UNC X 2" HEX BOLT
	45	8	910008 1/2UNC HEX NUT
	46	4	920004 1/2 SAE FLAT WASHER
	47	1	342625 STEERING MTR PLT, 2100 98
	48	4	618109 9/16MJIC-3/4MOR ADPTR
	49	1	749318 STRG MTR, 7.3CID, NON-LOAD 1031
	50	2	483031 1 3/8 X 7/8 X 18GA MACH WASHER
	51	1	470342 SNAP PLUG, .375 DIA.

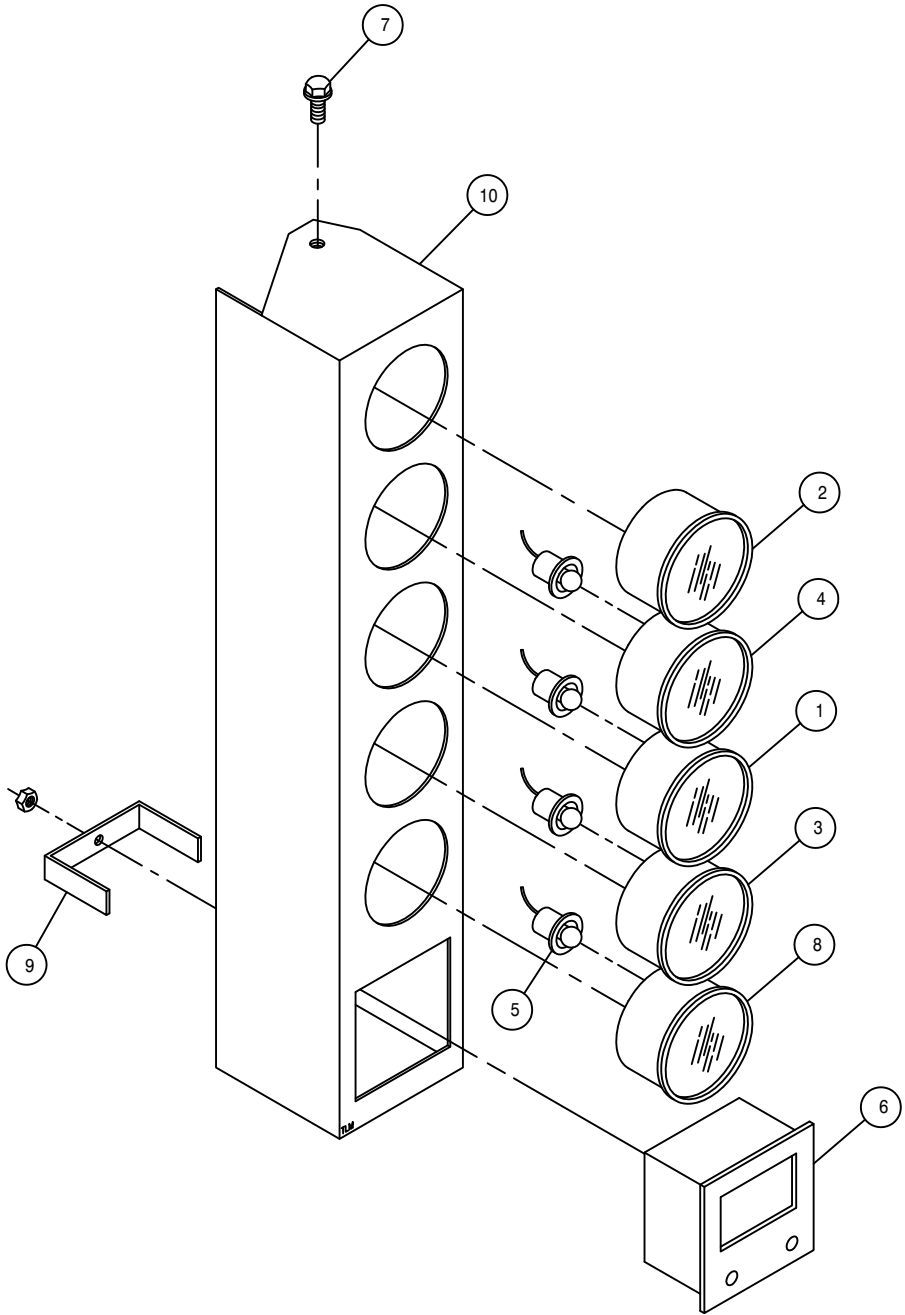

INSTRUMENT PANEL ASSEMBLY

DET.	QTY	PART NO.	DESCRIPTION
1	1	290401	FUEL GAUGE FOR 2.125 DIA HOLE
2	1	291203	HOUR METER, 12/24VDC BLACK BEZ
3	1	291673	OIL PRESS GAUGE, 125PSI
4	1	291611	VOLTMETER, 8V TO 18V DC
5	4	291612	LIGHT KIT FOR 2" GAUGE
6	1	291635	DIGITAL MPH/RPM INDICATOR
7	2	470122	1/4UNC X 1/2 FLANGE HEX BOLT
8	1	314436	TEMP GA 100-280 DEG LIGHTED
9	1	342068	DIGITAL MPH/RPM IND KEEPER 94
10	1	342533	INSTRU HSG WLD, 2100 98

CONSOLE COVER ASSEMBLY

DET. QTY PART NO. DESCRIPTION

1	2	291627	SWITCH,2P(ON)OFF(ON)	511-058
2	4	291628	LENS, GREEN	
3	1	291671	SWITCH,2P OFF/ONA/ONAB	511-138
4	1	291672	SWITCH,1P ON/OFF/ON	511-149
5	1	342504	CONSOLE TOP WLD, 2100	98
6	1	342509	CONSOLE LID ASSY, 2100	98
7	4	473966	6X3/4 PHIL FLT HD SHT MTL SCR	
8	6	903710	10-32X5/8 PHIL PANHD MACH SCR	

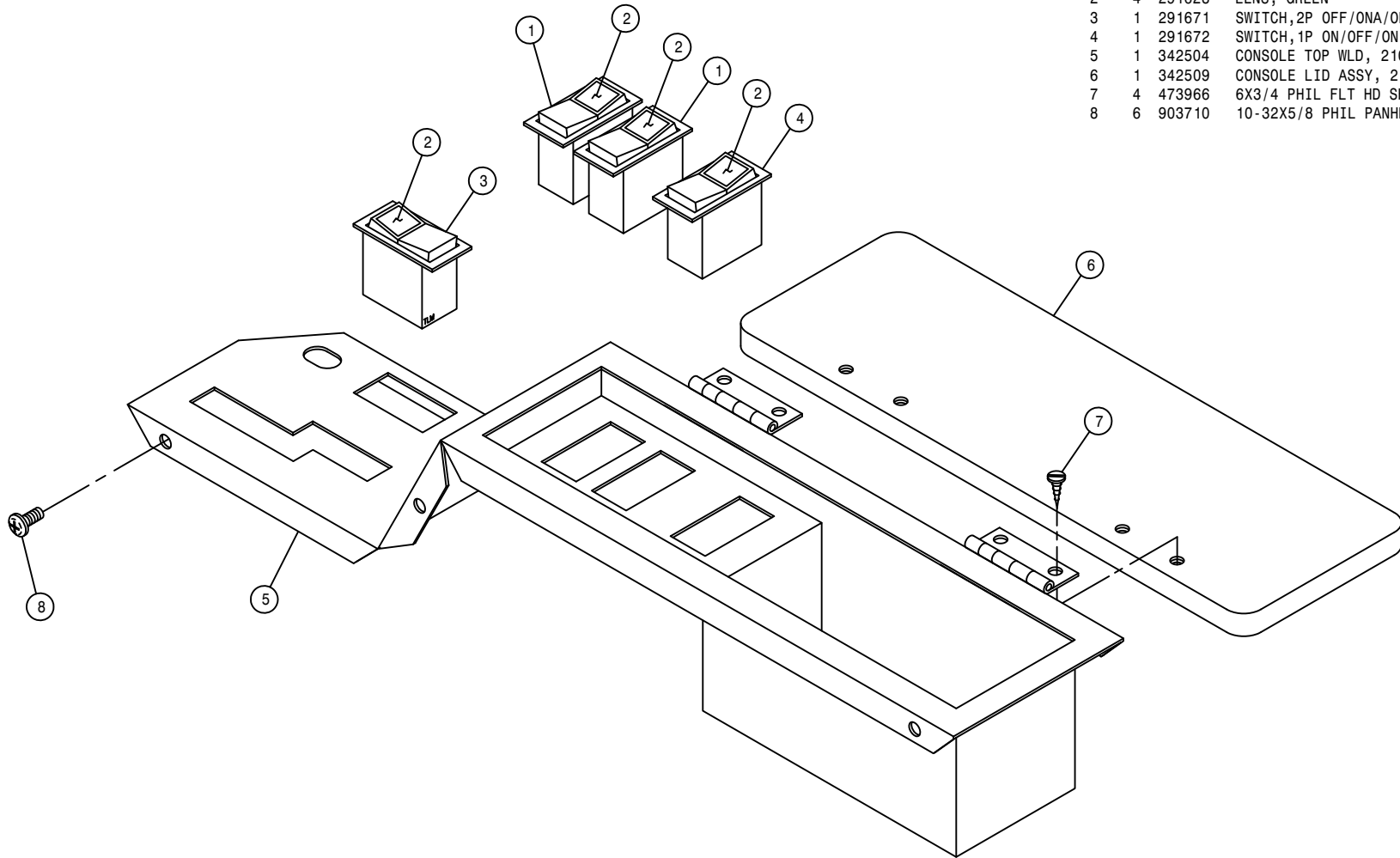



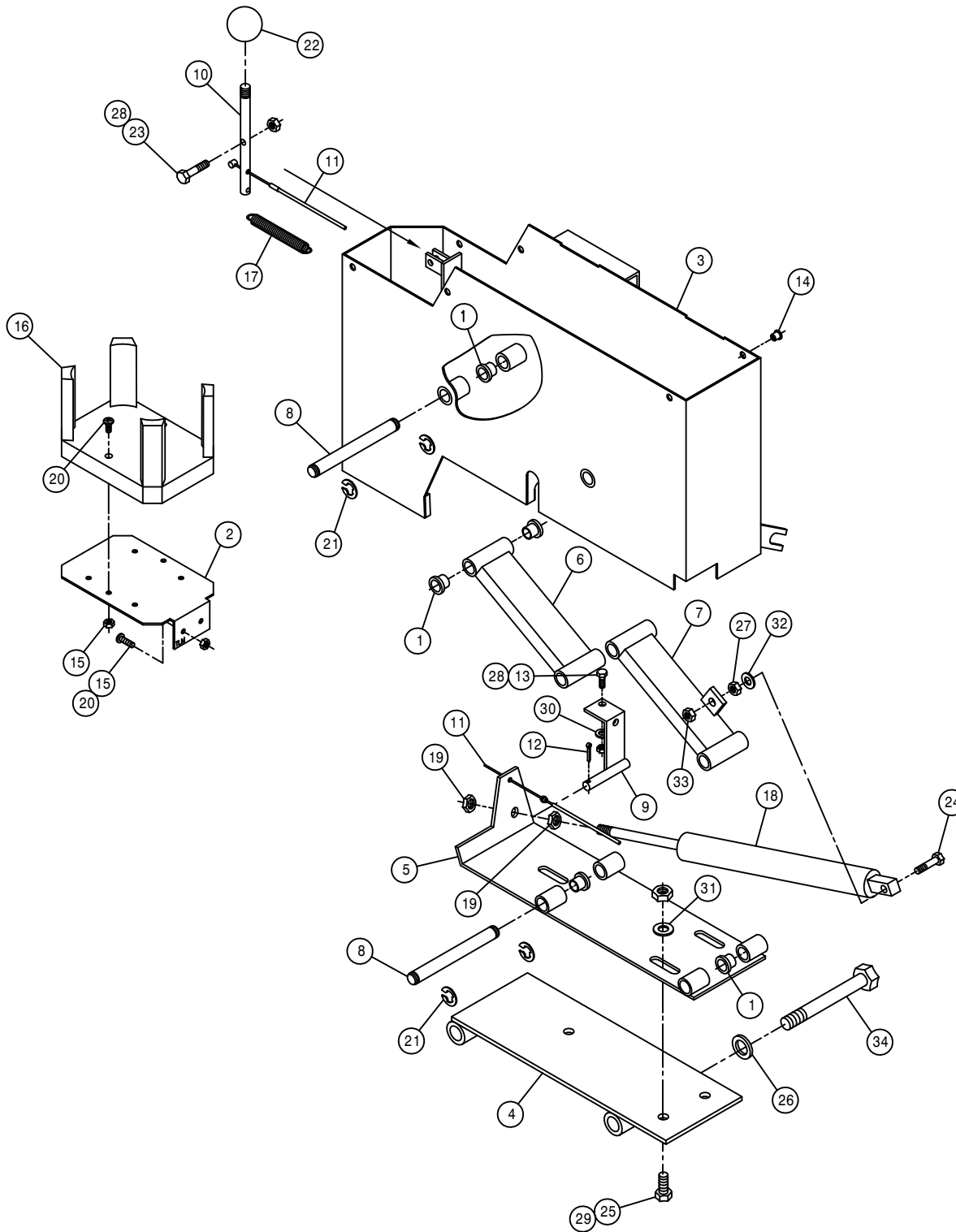

CONSOLE ASSEMBLY

DET. QTY PART NO. DESCRIPTION

1	16	127504	NYLINER FLG BRG, .500 ID
2	1	342216	DRINK HOLDER MT BRKT 94
3	1	342493	CONSOLE WLD, 2100 98
4	1	342510	CONSOLE SEAT MT WLD, 2100 98
5	1	342513	LWR CONSOLE MTG PLT WLD2100 98
6	1	342516	FRT CONSOLE PIVOT BRKT WLD 98
7	1	342519	REAR CONSOLE PIVOT BRKT WLD 98
8	4	342522	CONSOLE PIN, 2100 98
9	1	342523	AIR SHOCK RELEASE WLD, 2100 98
10	1	342526	ADJ HANDLE, 2100 98
11	1	342527	CONSOLE ADJ CABLE ASSY,2100 98
12	1	470006	COTTER PIN 1/8 X 1
13	1	470118	1/4UNC X 3/4 FLANGE HEX BOLT
14	6	470165	10-32 NUTSERT .020-.100 MATL
15	4	470175	10-32 HEX FLANGE LOCK NUT
16	1	470214	SPILLMASTER DRINK HOLDER
17	1	470248	SPRING,EXPANSION .438 X 3.00
18	1	470251	GAS SPRING, LOCKING 0250N
19	2	473830	10MM-1.00 HEX JAM NUT
20	4	903710	10-32X5/8 PHIL PANHD MACH SCR
21	8	629525	RING, RETAINING, .50DIA SHAFT
22	1	659291	KNOB,1" RND,BLK, 3/8-16
23	1	900003	1/4UNC X 1" HEX BOLT
24	1	900067	5/16UNC X 1 1/2 HEX BOLT
25	3	900129	3/8UNC X 1" HEX BOLT
26	2	920505	5/8 LOCK WASHER
27	1	910002	5/16UNC HEX NUT
28	2	914000	1/4UNC HEX STOVER NUT
29	3	914004	3/8UNC HEX STOVER NUT
30	1	920000	1/4 SAE FLAT WASHER
31	3	920002	3/8 SAE FLAT WASHER
32	1	920001	5/16 SAE FLAT WASHER
33	1	914002	5/16UNC HEX STOVER NUT
34	2	900346	5/8UNC X 6" HEX BOLT

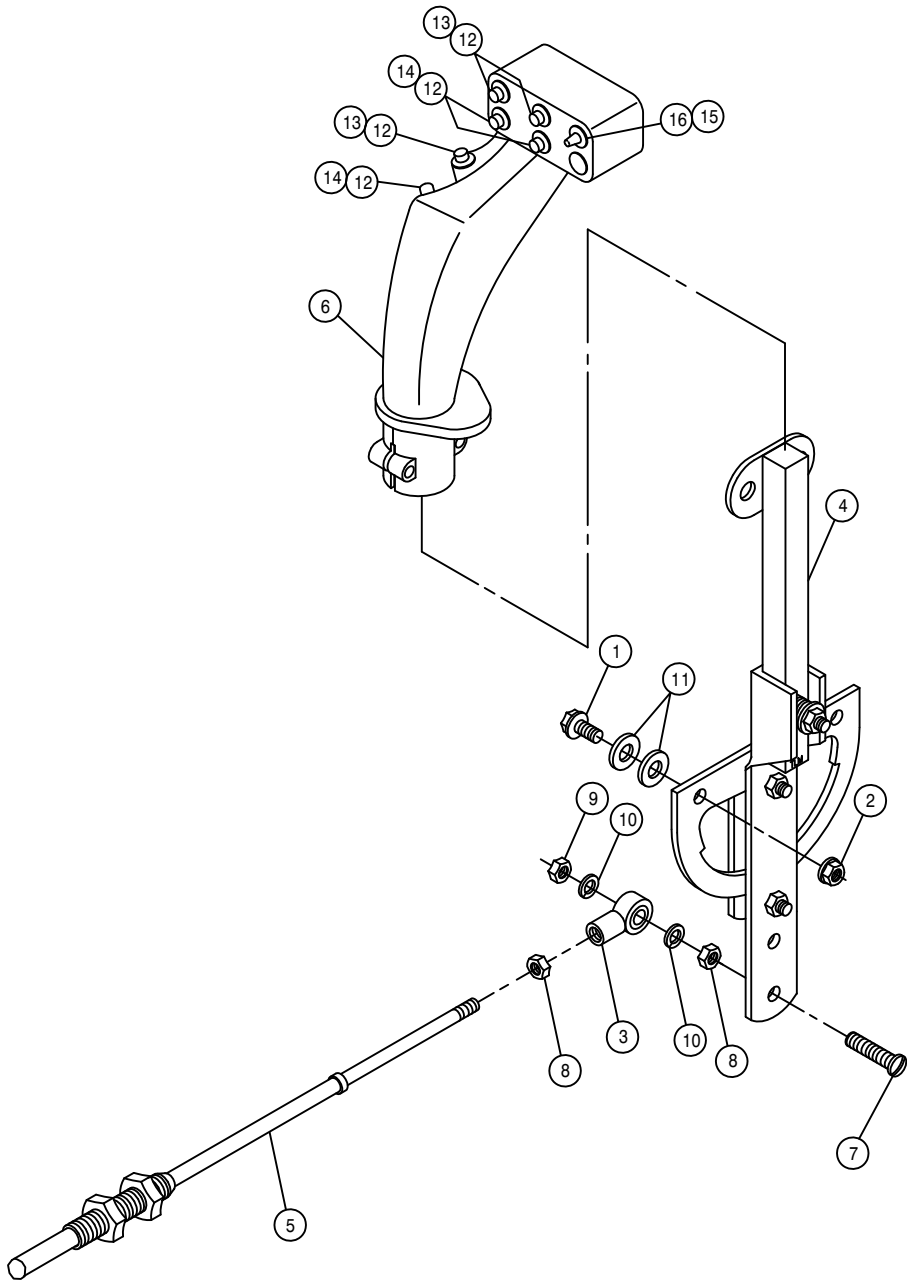

HYDROSTATIC LEVER ASSEMBLY

DET.	QTY	PART NO.	DESCRIPTION
	1	2 470118	1/4UNC X 3/4 FLANGE HEX BOLT
	2	2 470121	1/4UNC HEX FLANGE LOCK NUT
	3	1 473921	BALL JOINT NO 10-32 THD
	4	1 342528	HYDST CTRL LEVER ASSY, 2100 98
	5	1 785066	CTRL CABLE 10-32 4IN X 129 IN
	6	1 785078	FASSE EZ-3 CTRL HANDLE,284 96
	7	1 903893	10-32 X 1" SLT RD HD MACH SCR
	8	2 910027	10-32 HEX NUT
	9	1 914027	10-32 HEX STOVER NUT
	10	2 920510	#10 LOCK WASHER
	11	4 920000	1/4 SAE FLAT WASHER
	12	6 291650	SWITCH,SPDT MOM MICRO
	13	3 291651	SWITCH BOOT, GRAY -FOR 291650
	14	3 291652	SWITCH BOOT, RED -FOR 291650
	15	1 291654	SWITCH BOOT, BLACK-FOR 291653
	16	1 291653	SWITCH, TOG SPDT 3POS STAT

THROTTLE LEVER ASSEMBLY

DET.	QTY	PART NO.	DESCRIPTION
1	1	342529	THROT LEVER WLD, 2100 98
2	1	473921	BALL JOINT NO 10-32 THD
3	1	499001	SPRING HYDRO CONTROL
4	1	785007	KNOB,1 3/16" BALL,RED,3/8-16
5	1	785046	FRICTION DISC 3-333 X .38
6	1	785079	CTRL CABLE 10-32 4IN X 140 IN
7	1	900170	3/8UNC X 2 1/4 HEX BOLT
8	1	903893	10-32 X 1" SLT RD HD MACH SCR
9	2	910027	10-32 HEX NUT
10	1	914004	3/8UNC HEX STOVER NUT
11	1	914027	10-32 HEX STOVER NUT
12	1	920002	3/8 SAE FLAT WASHER
13	2	920510	#10 LOCK WASHER

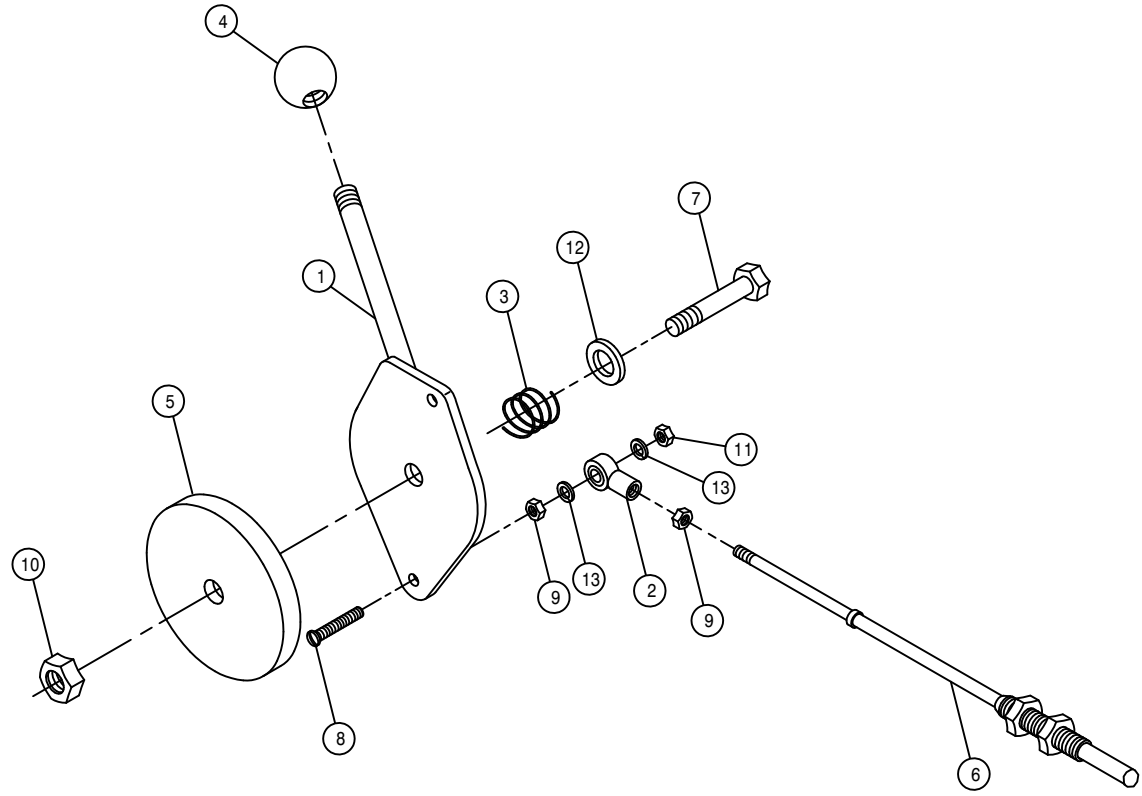

SWITCH PANEL ASSEMBLY

DET.	QTY	PART NO.	DESCRIPTION	
1	4	291623	SWITCH,2P ON/OFF	511-015
2	7	291625	SWITCH,2P ON/ON	511-108
3	4	291627	SWITCH,2P(ON)OFF(ON)	511-058
4	16	291628	LENS, GREEN	
5	1	291638	INDICATOR LIGHT, GREEN	
6	1	291647	DUAL BINDING POSTS	
7	1	291655	AIRCRAFT TOGGLE SWITCH GUARD	
8	1	291672	SWITCH,1P ON/OFF/ON	511-149
9	10	293246	END BEZEL	
10	5	293247	CENTER BEZEL	
11	1	298012	TOGGLE SWITCH	
12	1	321021	IGN SWITCH, NON-SEALED	
13	1	342531	SWITCH PANEL, 2100	98
14	1	342532	BOOM SWITCH PANEL, 2100	98
15	1	342422	SWITCH HOUSING WLD, 2100	98
16	1	342425	SWITCH HSG SUPP WLD, 2100	98
17	1	342428	MONITOR BRKT, 2100	98
18	16	470086	1/4UNC NUTSERT .020-.100MATL	
19	2	470118	1/4UNC X 3/4 FLANGE HEX BOLT	
20	2	470121	1/4UNC HEX FLANGE LOCK NUT	
21	4	900002	1/4UNC X 3/4 HEX BOLT	
22	1	900005	1/4UNC X 1 1/2 HEX BOLT	
23	10	903708	1/4UNC X1/2 PHIL PNHD MACHSCR	
24	3	914000	1/4UNC HEX STOVER NUT	
25	4	920000	1/4 SAE FLAT WASHER	
26	4	920500	1/4 LOCK WASHER	
27	1	690618	CONSOLE, RAVEN 460 W/GPS PORT	
28	2	900000	1/4UNC X 1/2 HEX BOLT	
29	2	291498	WIRE NUT, 22-16GA GRAY	
30	1	470070	GROMMET, .375ID .062GW .500GD	
31	1	390318	INDICATOR LIGHT, RED	
32	4	470339	SNAP PLUG, BLK NYL .250 DIA	

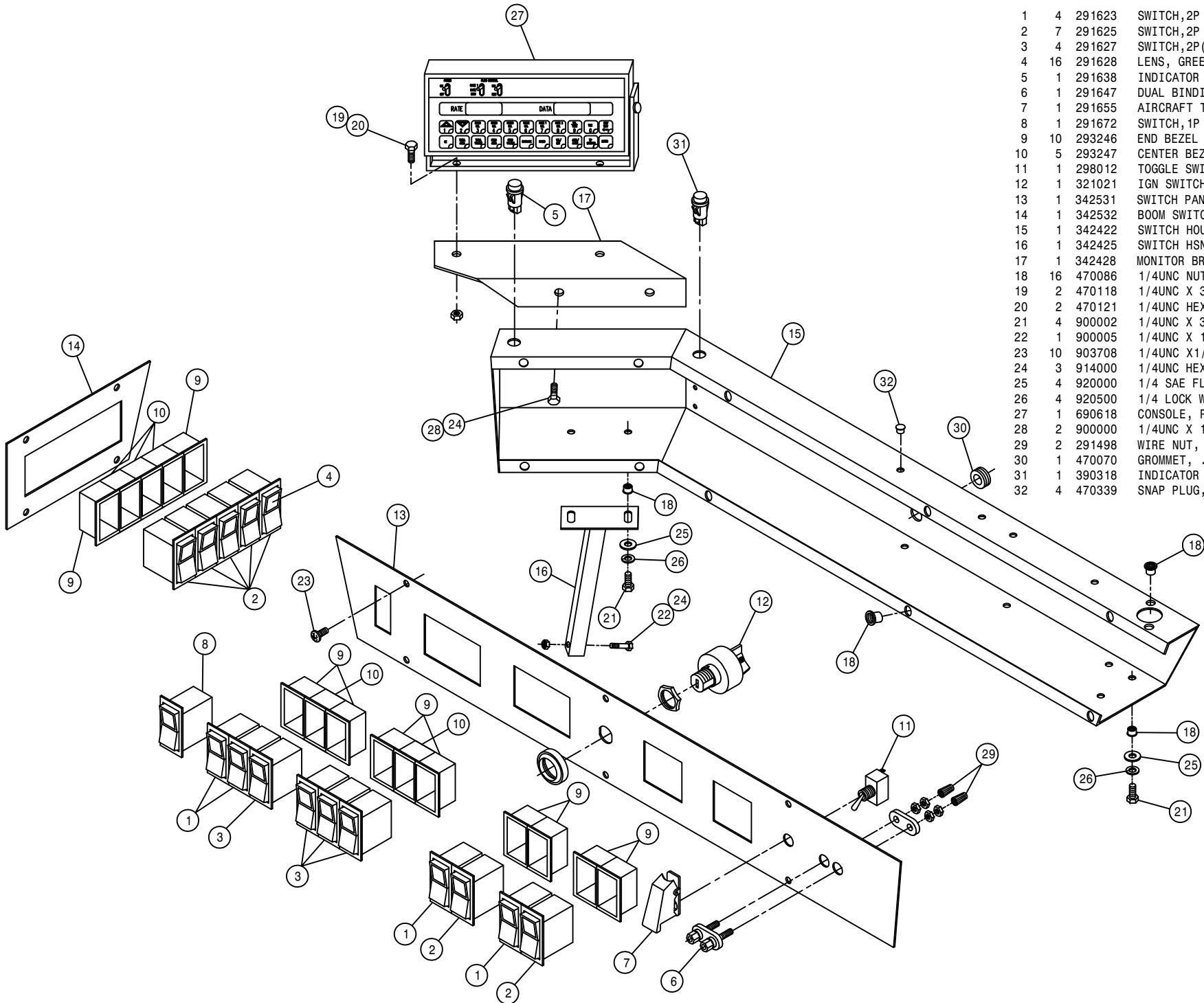

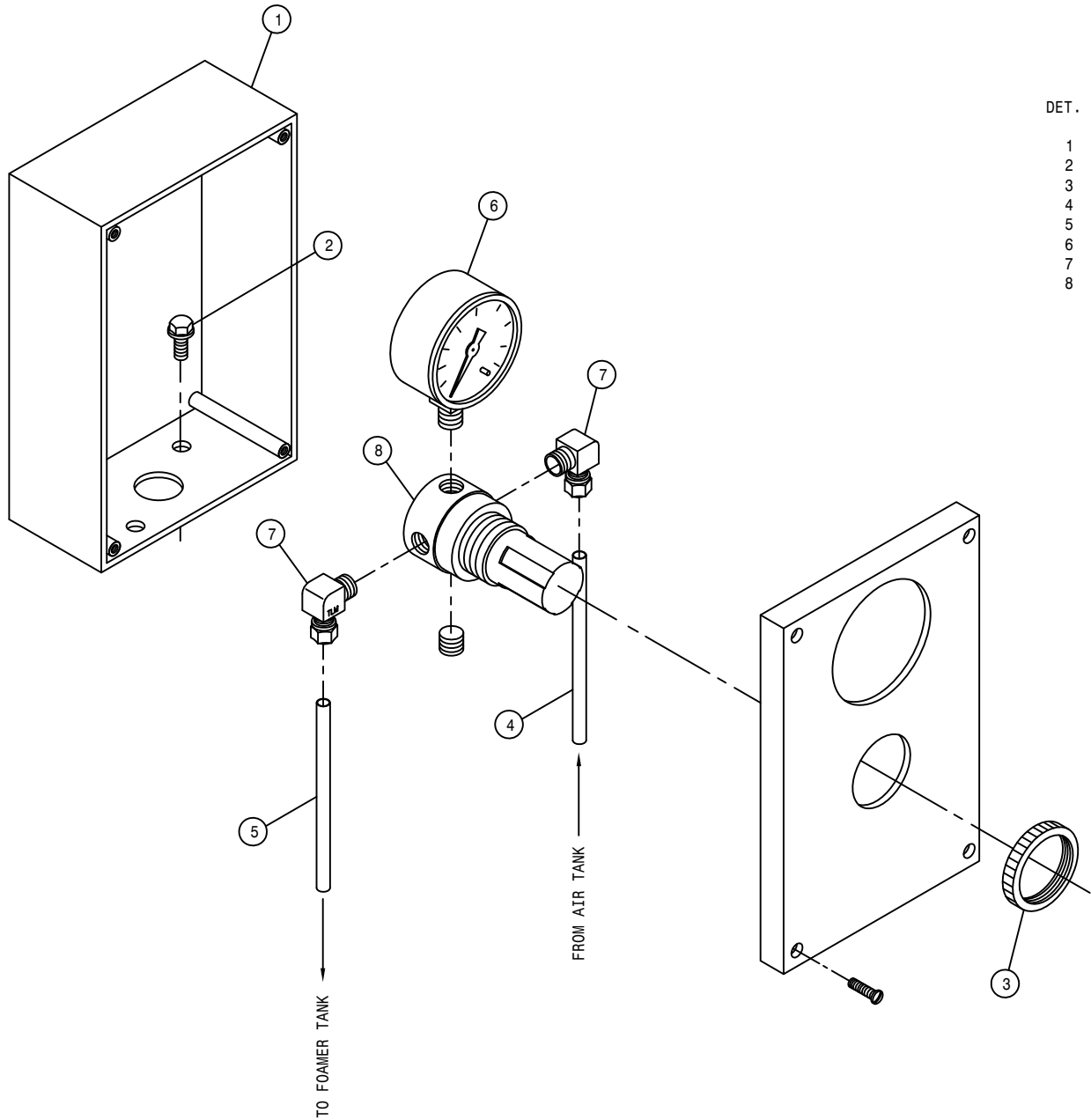

FOAMER AIR REGULATOR ASSEMBLY

DET. QTY PART NO. DESCRIPTION

1	1	342429	FOAMER AIR REG MT BOX, 2100 98
2	2	470122	1/4UNC X 1/2 FLANGE HEX BOLT
3	1	711021	1 1/4-18 NUT,AIR REGULATOR MT
4	1	601360	HOSE, 1/4 X 168 AIR
5	1	601418	HOSE, 1/4 X 228 AIR
6	1	701310	AIR PRESS GAUGE, 1/8"BOT
7	2	711016	1/4NPT-90-1/4NYL TUBE FTG BRS
8	1	711019	1/4"MNPT AIR REGULATOR

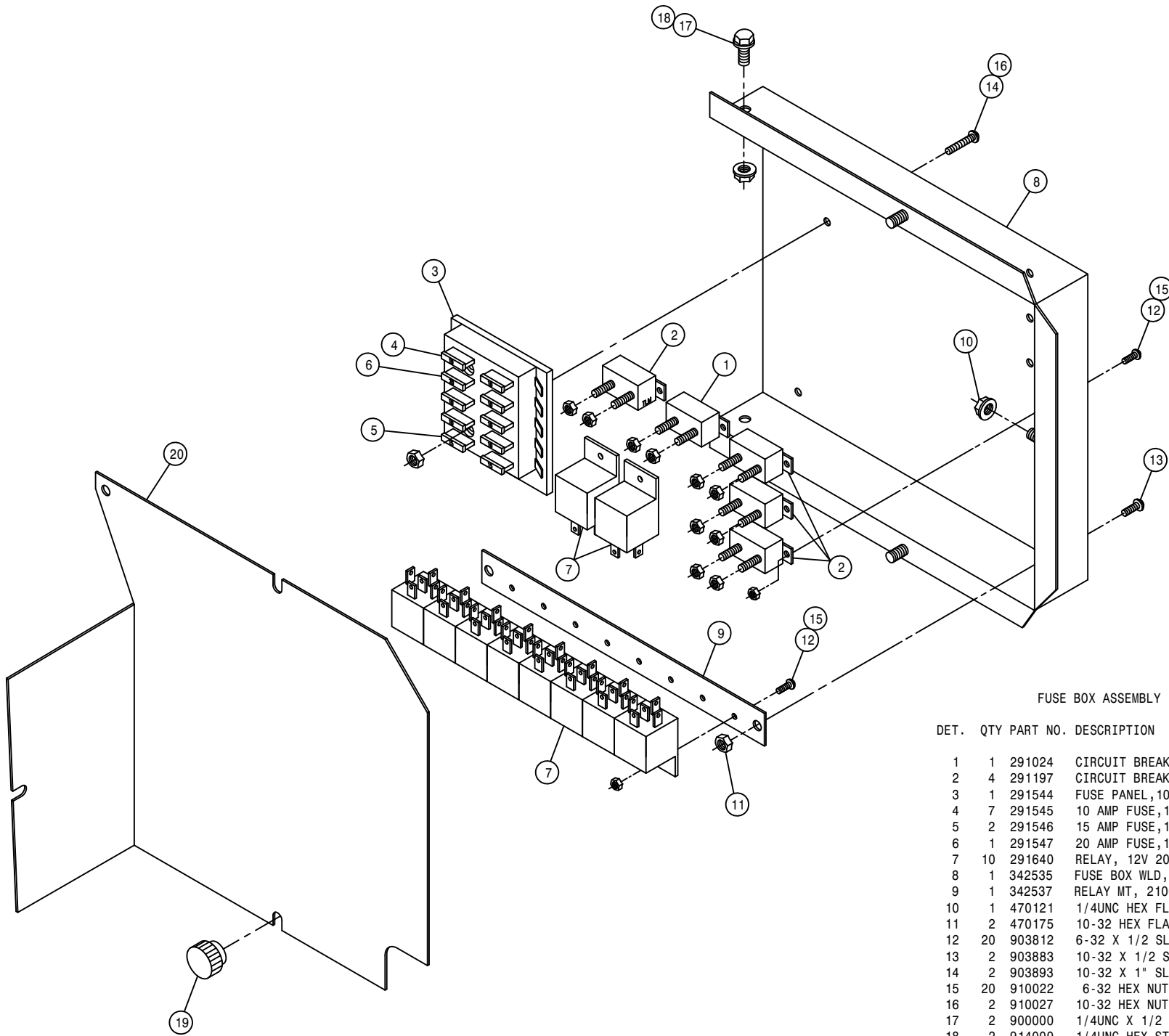

FUSE BOX ASSEMBLY

DET.	QTY	PART NO.	DESCRIPTION
	1	291024	CIRCUIT BREAKER,40AMP,INLINEMT
	4	291197	CIRCUIT BREAKER,30AMP,INLINEMT
	1	291544	FUSE PANEL,10 CIRCUIT,BLADE TP
	7	291545	10 AMP FUSE,1/4"BLADE ATO/ATC
	2	291546	15 AMP FUSE,1/4"BLADE ATO/ATC
	1	291547	20 AMP FUSE,1/4"BLADE ATO/ATC
	7	10	RELAY, 12V 20/30AMP BOSCH
	1	342535	FUSE BOX WLD, 2100 98
	1	342537	RELAY MT, 2100 98
	1	470121	1/4UNC HEX FLANGE LOCK NUT
	2	470175	10-32 HEX FLANGE LOCK NUT
	20	903812	6-32 X 1/2 SLT RD HD MACH SCR
	2	903883	10-32 X 1/2 SLT RDHD MACH SCR
	2	903893	10-32 X 1" SLT RD HD MACH SCR
	20	910022	6-32 HEX NUT
	2	910027	10-32 HEX NUT
	2	900000	1/4UNC X 1/2 HEX BOLT
	2	914000	1/4UNC HEX STOVER NUT
	3	470284	KNOB, .88 KNRLD, BLK, 1/4-20
	1	342431	FUSE BOX COVER, 2100

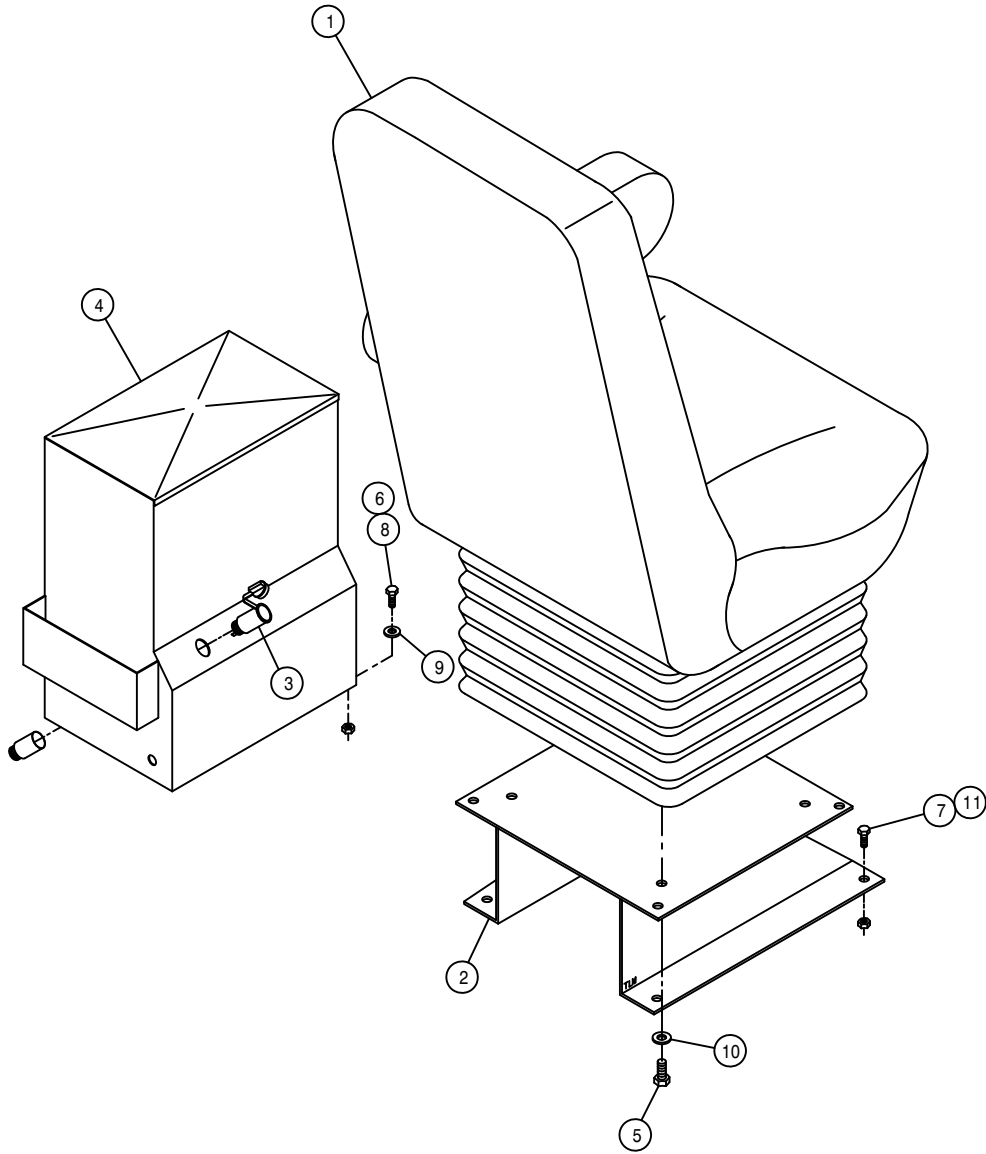

SEAT AND CONSOLE ASSEMBLY

DET. QTY PART NO. DESCRIPTION

DET.	QTY	PART NO.	DESCRIPTION	
1	1	330026	SEAT & AIR SUSP ASSY, 2100	98
2	1	342090	SEAT MT WELD, 254/284	95
3	1	291648	POWER POINT RECEPTACLE	
4	1	342432	LH CONSOLE WLD, 2100	98
5	4	473803	8MM-1.25 X 16MM HEX BOLT	
6	4	900002	1/4UNC X 3/4 HEX BOLT	
7	4	900129	3/8UNC X 1" HEX BOLT	
8	4	914000	1/4UNC HEX STOVER NUT	
9	4	920000	1/4 SAE FLAT WASHER	
10	4	920501	5/16 LOCK WASHER	
11	4	914004	3/8UNC HEX STOVER NUT	

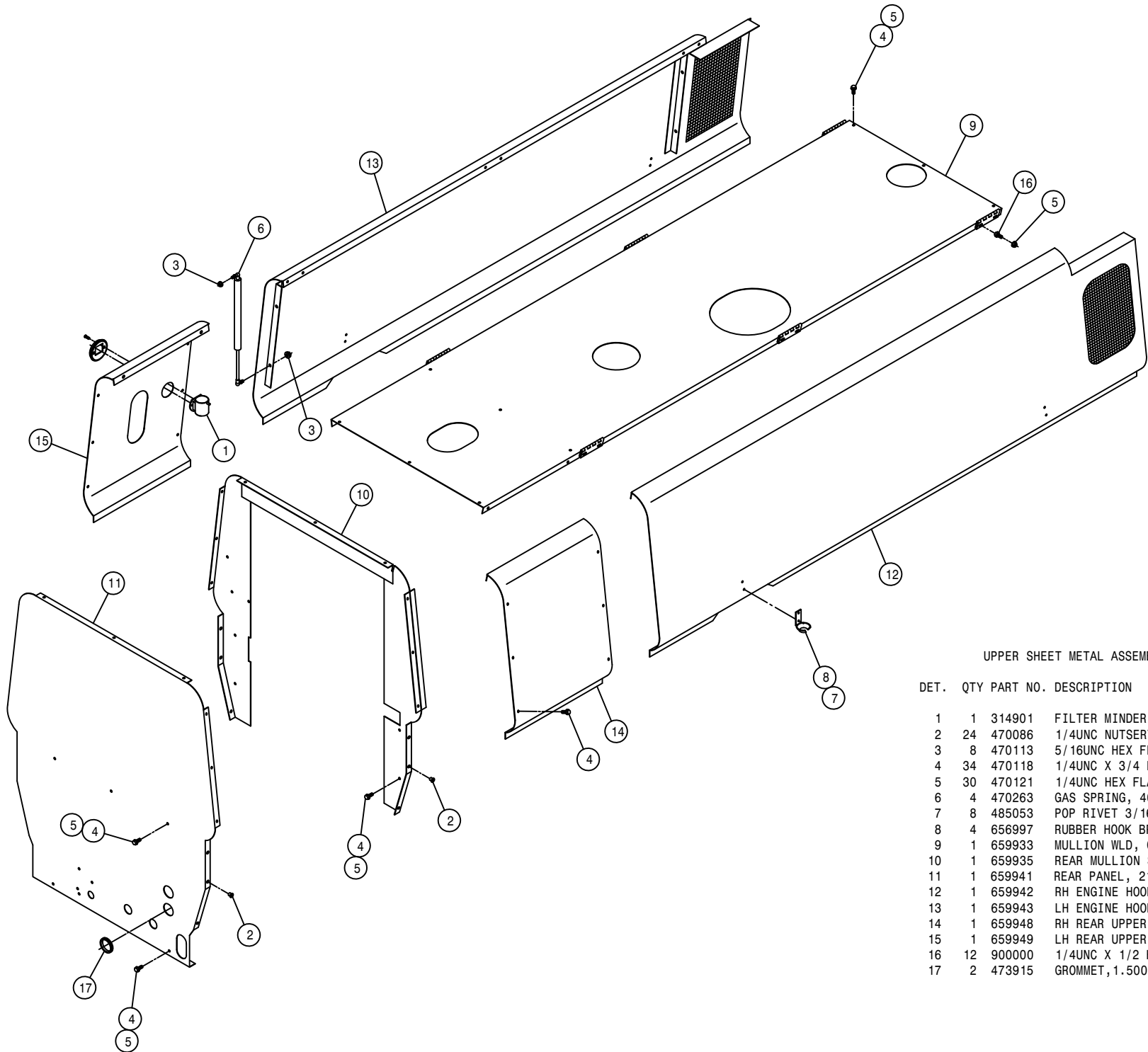

UPPER SHEET METAL ASSEMBLY

DET.	QTY	PART NO.	DESCRIPTION
	1	314901	FILTER MINDER AIR RESTRICT GA
	24	470086	1/4UNC NUTSERT .020-.100MATL
	8	470113	5/16UNC HEX FLANGE LOCK NUT
	34	470118	1/4UNC X 3/4 FLANGE HEX BOLT
	30	470121	1/4UNC HEX FLANGE LOCK NUT
	4	470263	GAS SPRING, 4016 8.00 STROKE
	8	485053	POP RIVET 3/16 X 3/8
	4	656997	RUBBER HOOK BRKT
	1	659933	MULLION WLD, CUMM, 2100 98
	1	659935	REAR MULLION SUPP WLD, 2100 98
	1	659941	REAR PANEL, 2100 98
	1	659942	RH ENGINE HOOD WLD, 2100 98
	1	659943	LH ENGINE HOOD WLD, 2100 98
	1	659948	RH REAR UPPER PANEL, 2100 98
	1	659949	LH REAR UPPER PANEL, 2100 98
	12	900000	1/4UNC X 1/2 HEX BOLT
	2	473915	GROMMET, 1.500ID .062GW 1.750GD



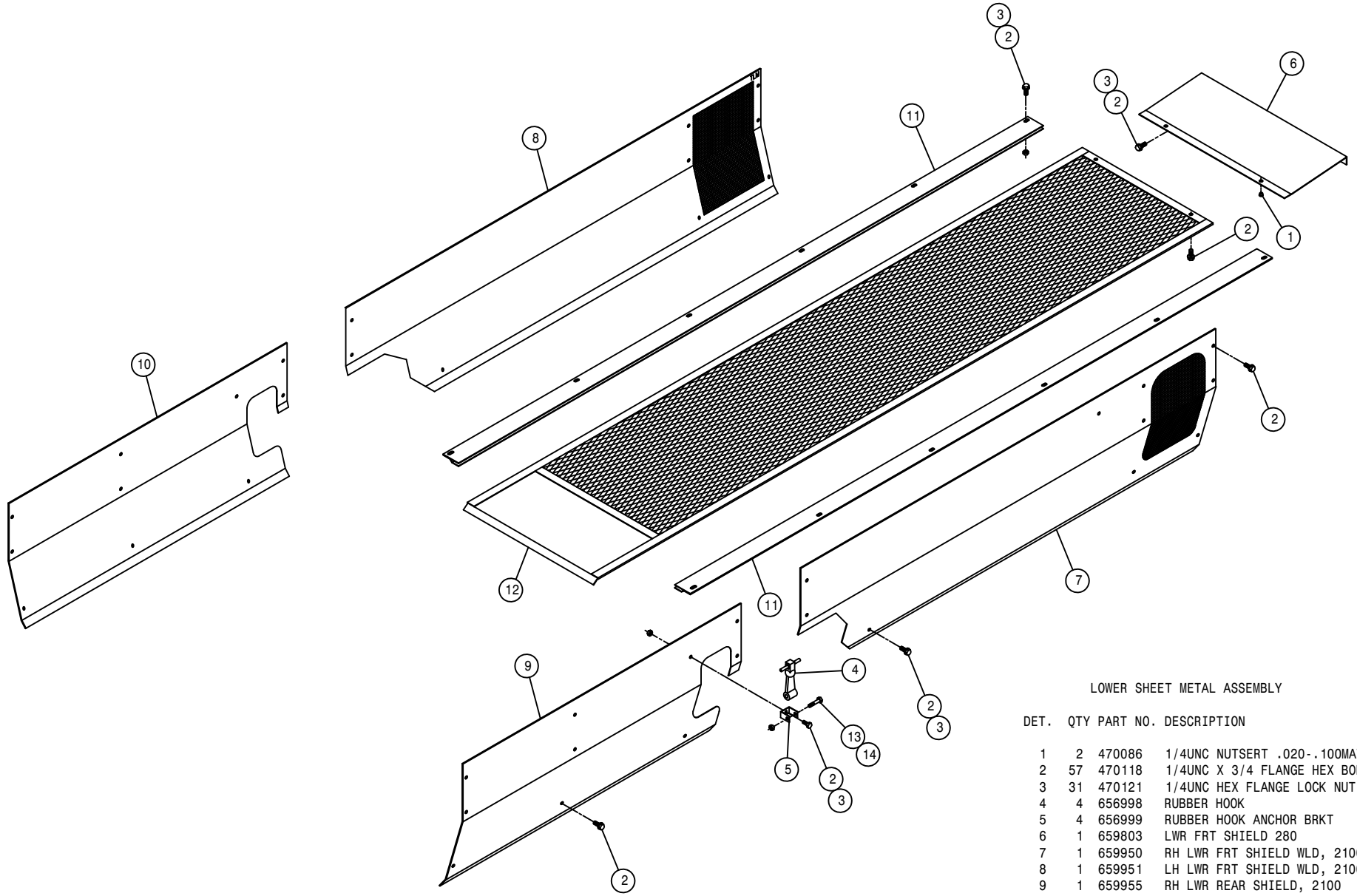

LOWER SHEET METAL ASSEMBLY

DET.	QTY	PART NO.	DESCRIPTION
1	2	470086	1/4UNC NUTSERT .020-.100MATL
2	57	470118	1/4UNC X 3/4 FLANGE HEX BOLT
3	31	470121	1/4UNC HEX FLANGE LOCK NUT
4	4	656998	RUBBER HOOK
5	4	656999	RUBBER HOOK ANCHOR BRKT
6	1	659803	LWR FRT SHIELD 280 89
7	1	659950	RH LWR FRT SHIELD WLD, 2100 98
8	1	659951	LH LWR FRT SHIELD WLD, 2100 98
9	1	659955	RH LWR REAR SHIELD, 2100 98
10	1	659956	LH LWR REAR SHIELD, 2100 98
11	2	659957	LWR SCR N SLIDE WLD, 2100 98
12	1	659960	LWR SCR N WLD, 2100 98
13	4	900005	1/4UNC X 1 1/2 HEX BOLT
14	4	914000	1/4UNC HEX STOVER NUT

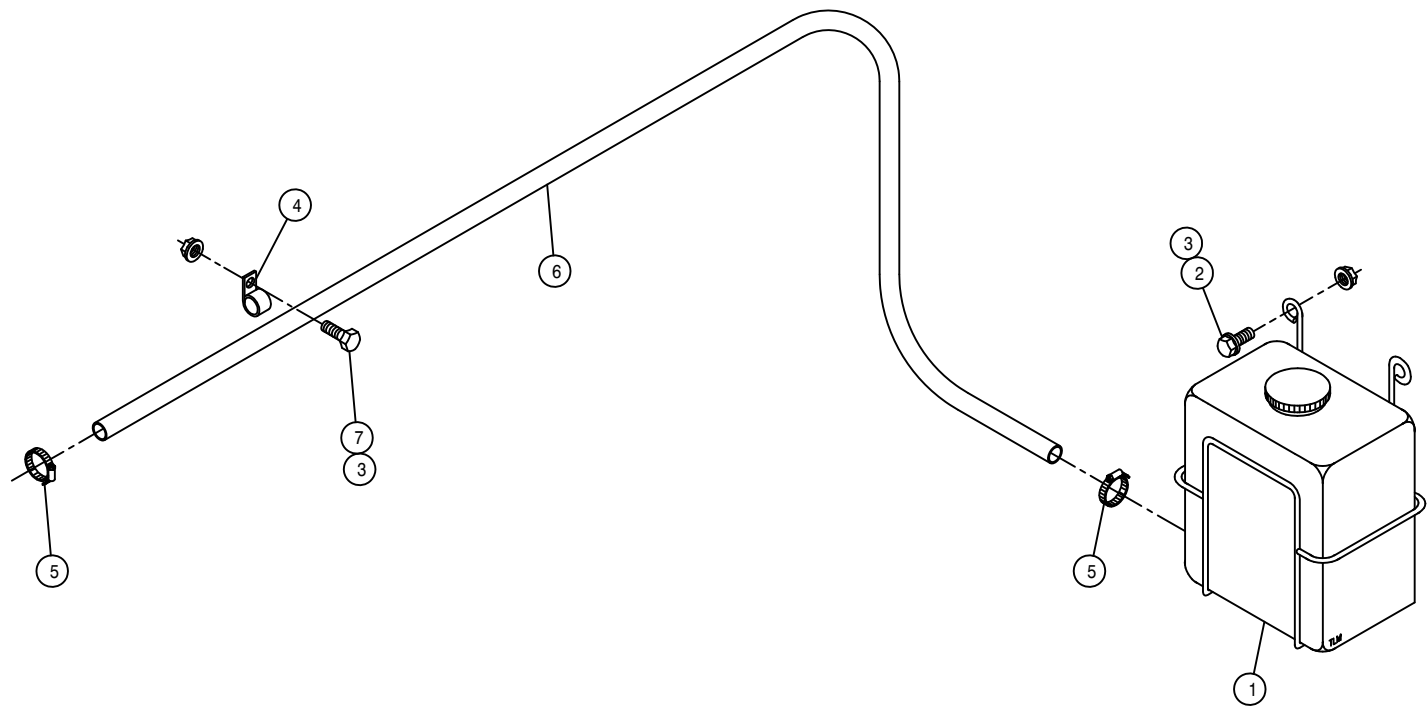

RADIATOR RECOVERY TANK ASSEMBLY

DET.	QTY	PART NO.	DESCRIPTION
	1	314767	RAD RECOVERY TANK & MTG WLD
	3	470118	1/4UNC X 3/4 FLANGE HEX BOLT
	7	470121	1/4UNC HEX FLANGE LOCK NUT
	4	520118	CUSH HOSE CLAMP 1/2D X 1/2W
	5	520120	HOSE CLAMP NO 4 STAINLESS
	6	601424	HOSE, 5/16 X 114 EPDM
	4	900002	1/4UNC X 3/4 HEX BOLT

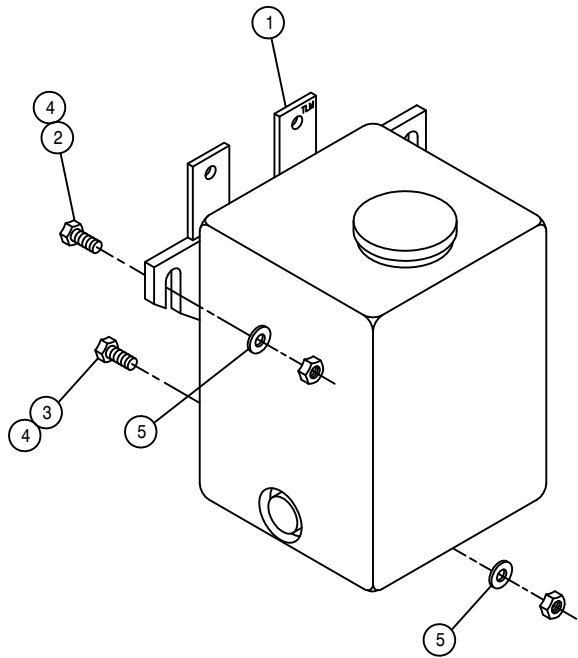

WINDSHIELD WASHER ASSEMBLY

DET.	QTY	PART NO.	DESCRIPTION
	1	290004	WINDSHIELD WASHER TANK ASSY 98
	2	900002	1/4UNC X 3/4 HEX BOLT
	3	900004	1/4UNC X 1 1/4 HEX BOLT
	4	914000	1/4UNC HEX STOVER NUT
	5	920000	1/4 SAE FLAT WASHER

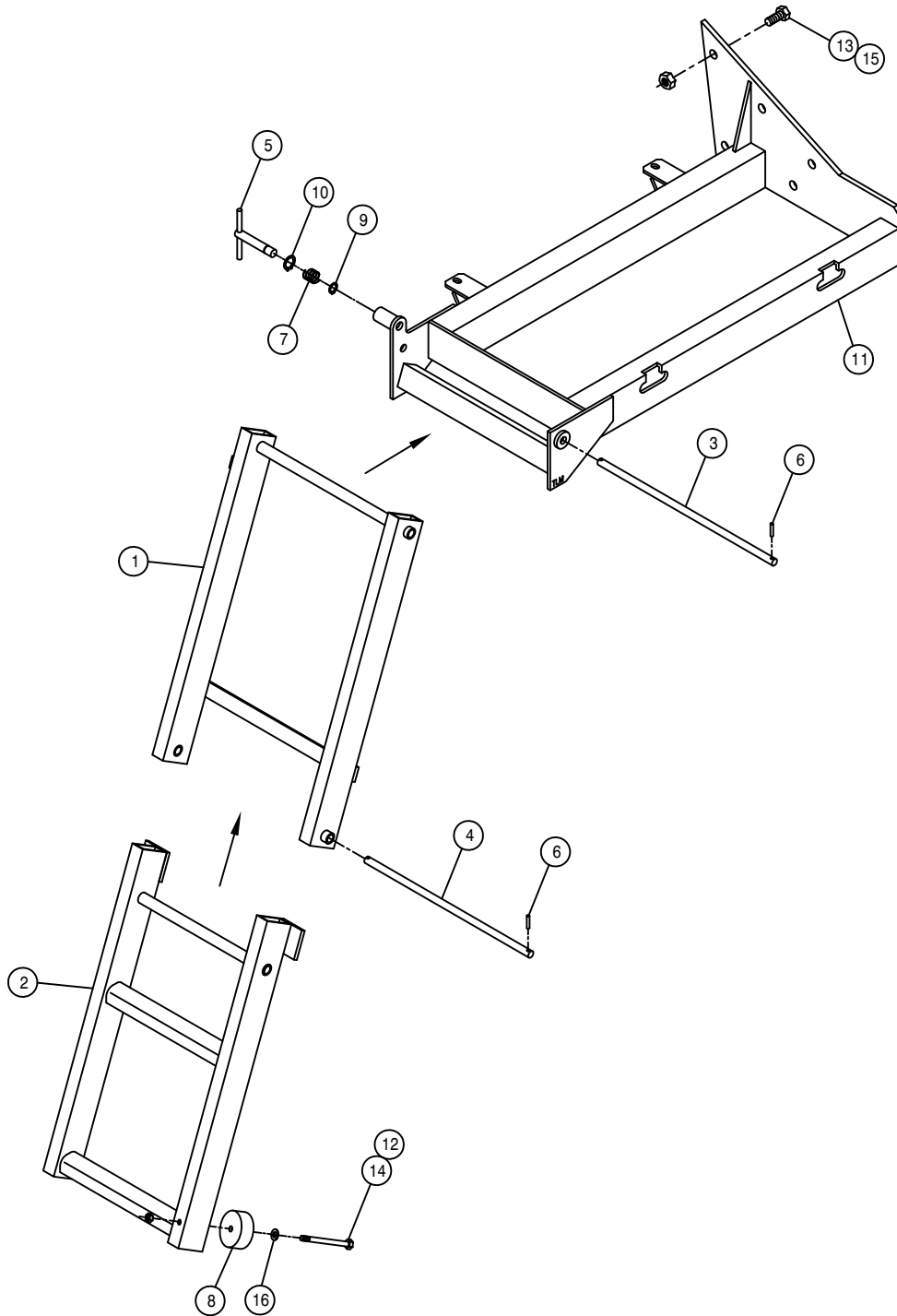

RIGHT FOLDING LADDER ASSEMBLY

DET. QTY PART NO. DESCRIPTION

1	1	342583	FOLD LDDR UPR SECT WLD,2100 98
2	1	342589	FOLD LDDR LWR SECT WLD,2100 98
3	1	342594	FOLD LADDER UPR PIVOT PIN 98
4	1	342595	FOLD LADDER LWR PIVOT PIN 98
5	1	342596	FOLD LDDR LOCK PIN WLD,2100 98
6	4	473928	ROLL PIN, 3/16 X 1
7	1	482131	3/4 X 1 3/4 COMPRSN SPRING
8	1	470098	RUBBER BUMPER 2.500D X .38ID
9	1	629534	SNAP RING, 9/16 EXTERNAL
10	1	629535	SNAP RING, 3/4 INTERNAL
11	1	760215	RH FUEL TANK MT WLD, 2100 98
12	1	900072	5/16UNC X 3" HEX BOLT
13	6	900334	5/8UNC X 1 3/4 HEX BOLT
14	1	910002	5/16UNC HEX NUT
15	6	914010	5/8UNC HEX STOVER NUT
16	1	920001	5/16 SAE FLAT WASHER

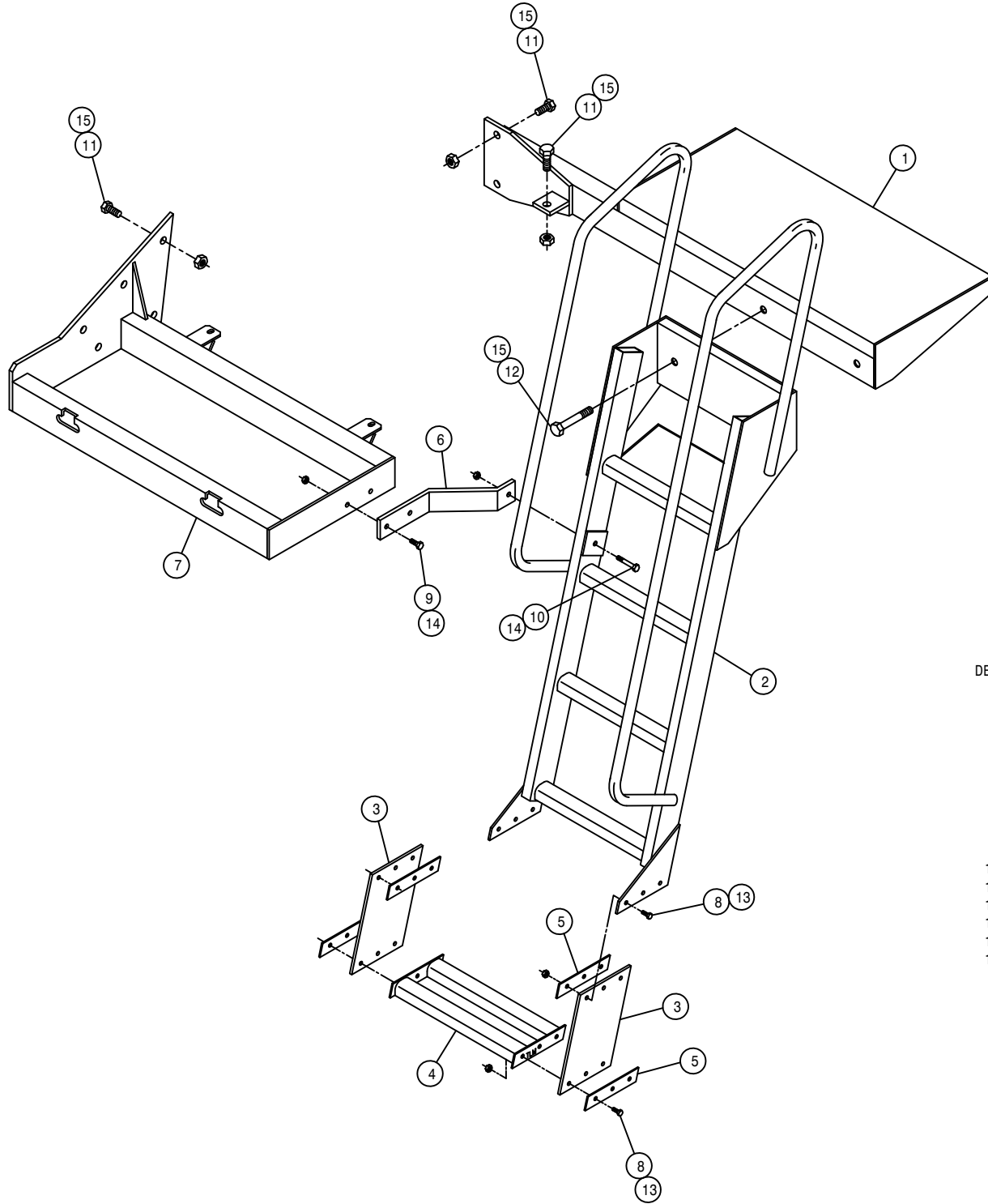

LEFT LADDER ASSEMBLY

DET. QTY PART NO. DESCRIPTION

1	1	342599	LH LADDER MT WLD, 2100	98
2	1	342605	LH LADDER WLD, 2100	98
3	2	342614	LADDER SIDE, LWR STEP, 2100	98
4	1	342615	LADDER STEP WLD, 2100	98
5	4	342616	LWR STEP SIDE KEEPER, 2100	98
6	1	342618	LH LADDER SUPP BRKT, 2100	98
7	1	760216	LH FUEL TANK MT WLD, 2100	98
8	12	900065	5/16UNC X 1" HEX BOLT	
9	2	900130	3/8UNC X 1 1/4 HEX BOLT	
10	1	900133	3/8UNC X 2" HEX BOLT	
11	9	900334	5/8UNC X 1 3/4 HEX BOLT	
12	2	900829	5/8UNC X 4" HEX BOLT GR8	
13	12	914002	5/16UNC HEX STOVER NUT	
14	3	914004	3/8UNC HEX STOVER NUT	
15	11	914010	5/8UNC HEX STOVER NUT	

FUEL TANK ASSEMBLY

DET. QTY PART NO. DESCRIPTION

1	2	291428	FUEL SENDER 19 IN.	
2	10	473902	NO 8 X 1/2 PAN HD MET SC	
3	2	501102	1/4 PIPE PLUG	
4	8	501451	BLK PIPE EL 90DEG .25NPT	
5	4	501602	BLK PIPE NIPPLE .25NPT-1.50	
6	2	760179	FUEL TANK WLD, 2100	98
7	2	761200	GAS CAP	
8	2	783303	1/4 NPT X 5/16 HOSE BARB, BRS	
9	2	783304	1/4 NPT X 3/8 HOSE BARB, BRS	
10	4	760184	FUEL TANK BAND WLD, 2100	98
11	4	914004	3/8UNC HEX STOVER NUT	
12	14	520120	HOSE CLAMP NO 4 STAINLESS	
13	1	601421	HOSE, 5/16 X 50 FUEL LINE	
14	1	601546	HOSE, 3/8 X 108 FUEL LINE	
15	1	601354	HOSE, 5/16 X 100 FUEL LINE	
16	1	601545	HOSE, 5/16 X 108 FUEL LINE	
17	1	601355	HOSE, 3/8 X 100 FUEL LINE	
18	1	601322	HOSE, 3/8 X 26 FUEL LINE	
19	1	610529	FUEL SELECTOR VALVE W/RETURN	
20	1	610530	5 WIRE CONNECTOR FOR 610529	
21	2	900064	5/16UNC X 3/4 HEX BOLT	
22	2	316281	FUEL STRAINER, IN-LINE, DIESEL	
23	2	601528	HOSE, 3/8 X 9 FUEL LINE	

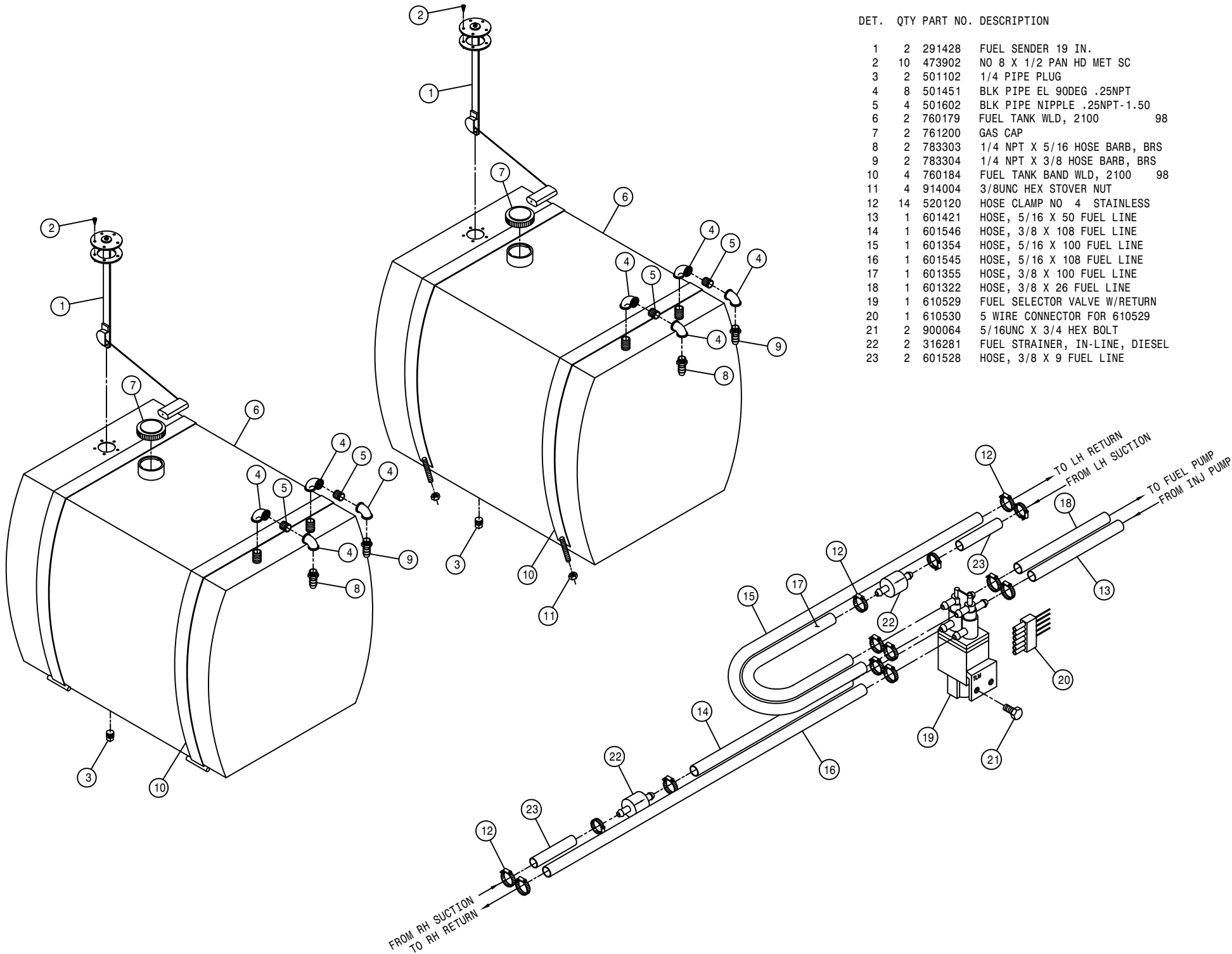

SERVICE PLATFORM ASSEMBLY

DET.	QTY	PART NO.	DESCRIPTION
1	2	293403	TAIL/TURN LIGHT ASSY, 2100 98
2	2	341900	SERVICE PLATFORM MT KPR 90
3	1	342538	RH SERVICE PLATFORM WLD2100 98
4	1	342539	LH SERVICE PLATFORM WLD2100 98
5	1	342548	REAR SERV PLATFORM WLD,2100 98
6	2	342565	CNTR SERV PLTRFM MT PLT2100 98
7	1	342566	RH UPPER SIDE RAIL TUBE WLD 98
8	1	342567	LH UPPER SIDE RAIL TUBE WLD 98
9	1	342576	REAR HANDRAIL WLD, 2100 98
10	1	342626	RH FRT TREAD ADJ GAUGE WLD 98
11	1	342627	LH FRT TREAD ADJ GAUGE WLD 98
12	1	342641	REAR HANDRAIL EXT WLD, 2100 98
13	1	342645	STEP EXT WLD, 2100 98
14	1	342650	RH REAR TRD IND WLD, 2100 98
15	1	342651	LH REAR TRD IND WLD, 2100 98
16	4	470118	1/4UNC X 3/4 FLANGE HEX BOLT
17	4	470121	1/4UNC HEX FLANGE LOCK NUT
18	1	472251	MTG SOCKET
19	1	656886	SLO MOVING VEHICLE SIGN ASSY
20	1	659852	SMV SIGN MTG BRKT 8200 89
21	1	900005	1/4UNC X 1 1/2 HEX BOLT
22	4	900068	5/16UNC X 1 3/4 HEX BOLT
23	10	900065	5/16UNC X 1" HEX BOLT
24	24	900129	3/8UNC X 1" HEX BOLT
25	4	900271	1/2UNC X 3 1/4 HEX BOLT
26	1	914000	1/4UNC HEX STOVER NUT
27	14	914002	5/16UNC HEX STOVER NUT
28	8	914008	1/2UNC HEX STOVER NUT
29	24	914004	3/8UNC HEX STOVER NUT
30	1	164364	RH LIFTARM V-PLT MT WLD2100 98
31	1	164365	LH LIFTARM V-PLT MT WLD2100 98
32	4	900265	1/2UNC X 1 1/2 HEX BOLT

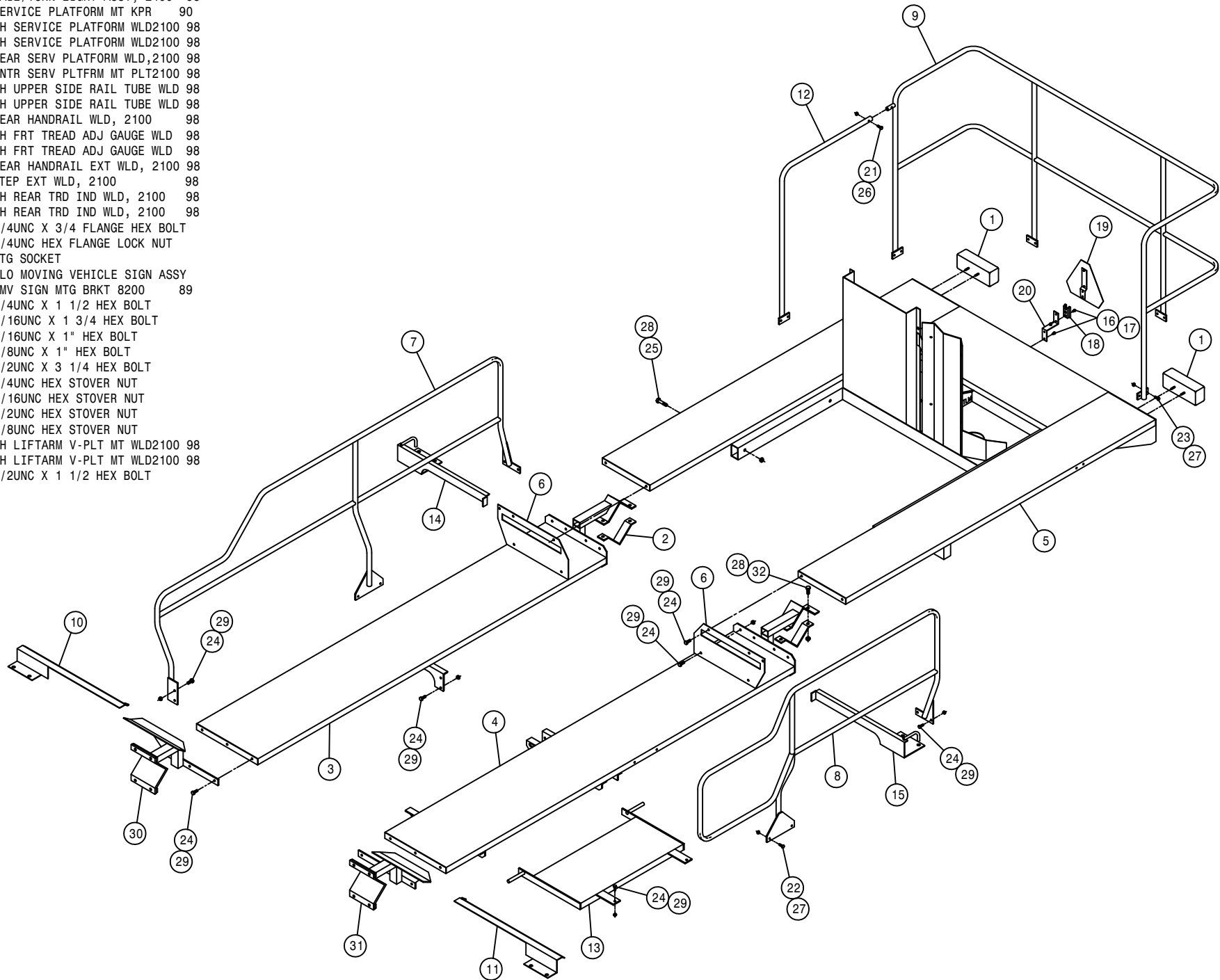

55

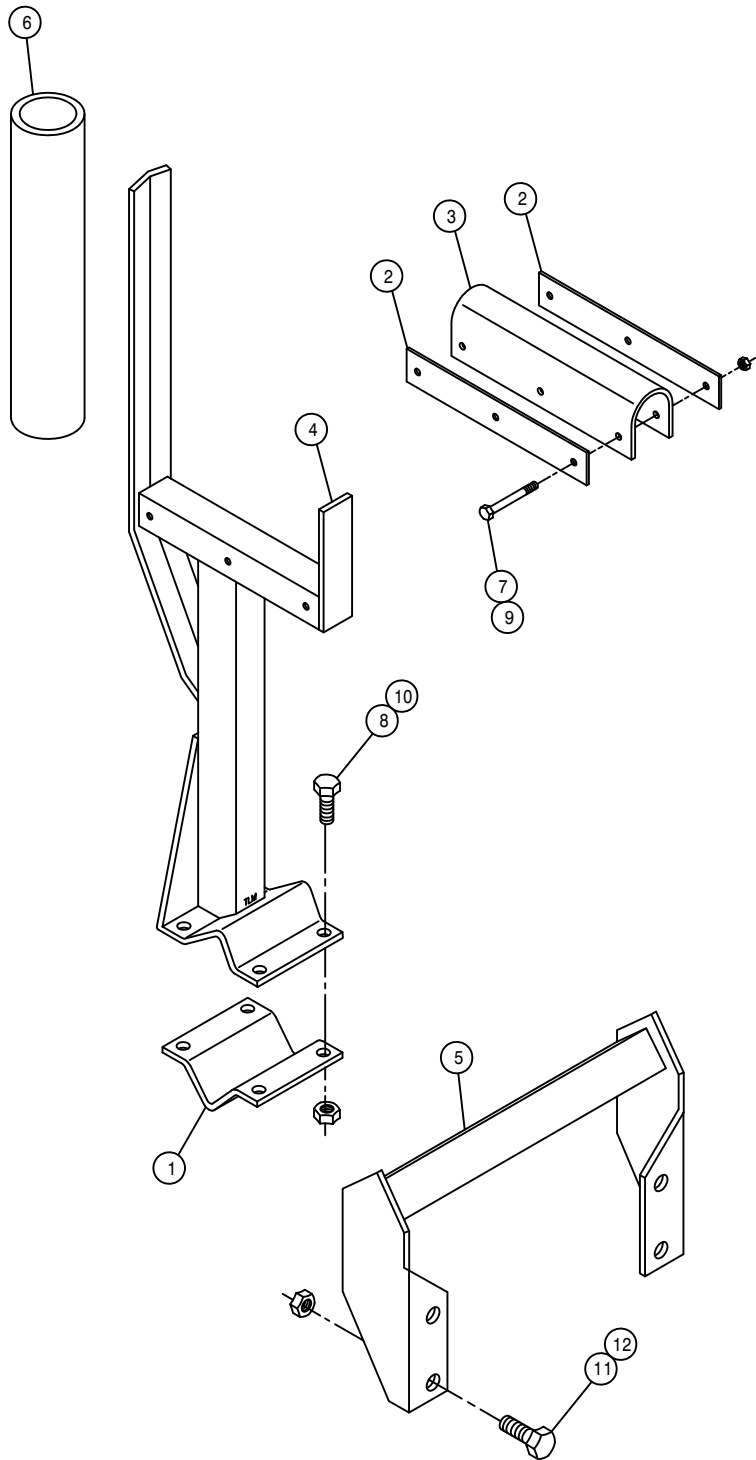

BOOM CRADLE ASSEMBLY

DET. QTY PART NO. DESCRIPTION

1	2	164253	BOOM CRADLE V-PLATE KEEPER	96
2	4	164254	CRADLE CUSHION KEEPER	96
3	2	164256	BOOM CRADLE CUSHION	96
4	2	164372	BOOM CRADLE WLD, 2100	98
5	2	164376	BOOM CRADLE MT WLD, 2100	98
6	2	601184	HOSE, 1 1/2 X 14 2BR BLK EPDM	
7	6	900008	1/4UNC X 2 1/2 HEX BOLT	
8	8	900265	1/2UNC X 1 1/2 HEX BOLT	
9	6	914000	1/4UNC HEX STOVER NUT	
10	8	914008	1/2UNC HEX STOVER NUT	
11	8	900334	5/8UNC X 1 3/4 HEX BOLT	
12	8	914010	5/8UNC HEX STOVER NUT	

NOTE: QUANTITY LISTED IS FOR ONE MACHINE.



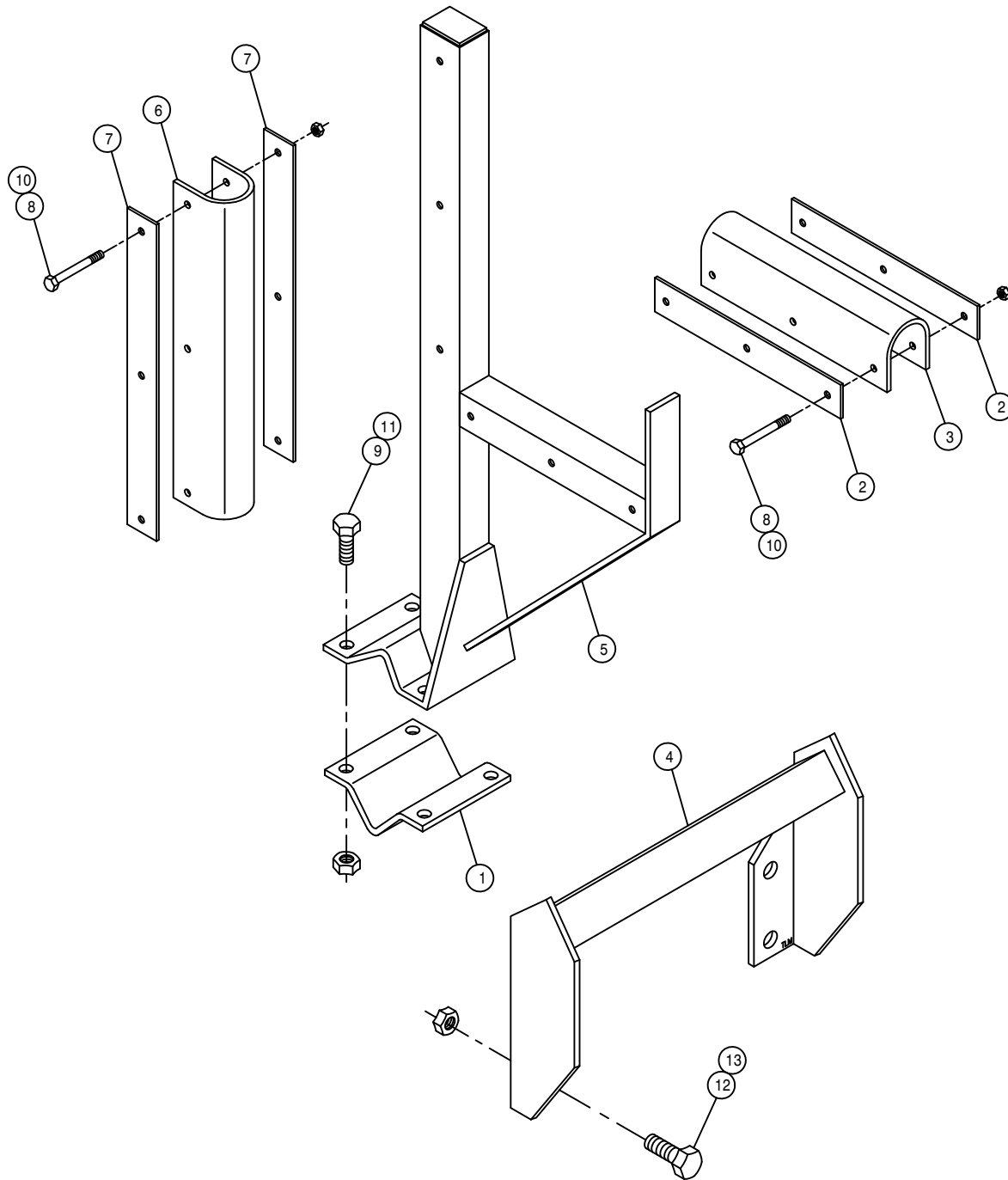

154" TREAD ADJUST CRADLE ASSEMBLY

DET.	QTY	PART NO.	DESCRIPTION
1	2	164253	BOOM CRADLE V-PLATE KEEPER 96
2	4	164254	CRADLE CUSHION KEEPER 96
3	2	164256	BOOM CRADLE CUSHION 96
4	2	164376	BOOM CRADLE MT WLD, 2100 98
5	2	164391	BOOM CRADLE WLD, 2100 154" TRD98
6	2	164395	BOOM CRADLE CUSHION, LONG 98
7	4	164396	CUSHION CRADLE KEEPER, LONG 98
8	12	900008	1/4UNC X 2 1/2 HEX BOLT
9	8	900265	1/2UNC X 1 1/2 HEX BOLT
10	12	914000	1/4UNC HEX STOVER NUT
11	8	914008	1/2UNC HEX STOVER NUT
12	8	900334	5/8UNC X 1 3/4 HEX BOLT
13	8	914010	5/8UNC HEX STOVER NUT

NOTE: QUANTITY LISTED IS FOR ONE MACHINE.

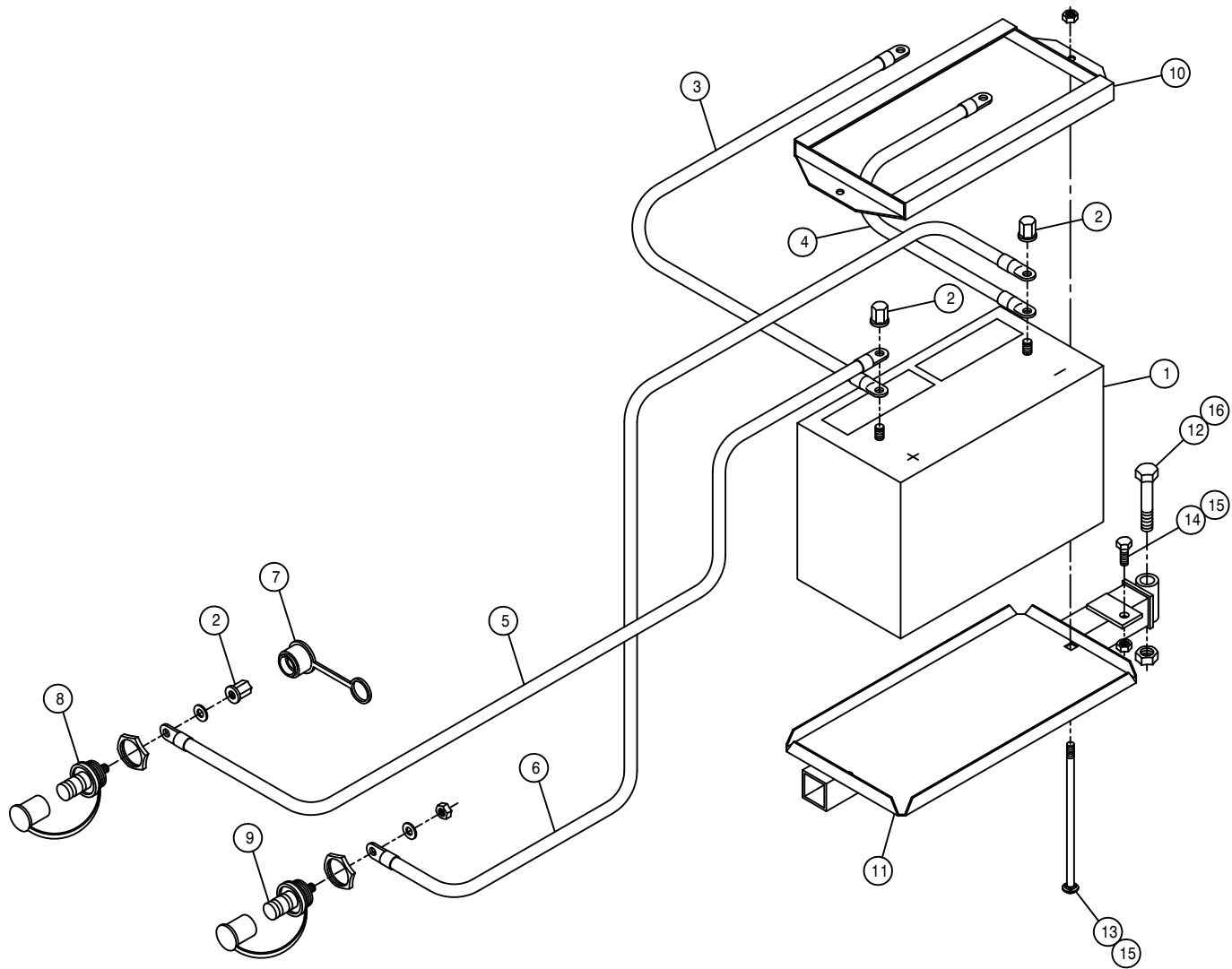

BATTERY BOX ASSEMBLY

DET.	QTY	PART NO.	DESCRIPTION
1	1	291196	BATTERY, 12V 950CCA, SS STUD
2	3	291205	BATTERY NUT, 3/8-16 SS CLSD CAP
3	1	291532	BATT CABLE, RED 50" 1/0 3/8-3/8
4	1	291534	BATT CABLE, BLK 50" 1/0 3/8-3/8
5	1	291533	BATT CABLE, RED 74" 1/0 3/8-3/8
6	1	291535	BATT CABLE, BLK 84" 1/0 3/8-3/8
7	1	291679	BATTERY NUT COVER, POSITIVE-RED
8	1	291680	POSITIVE JUMPER STUD, RED
9	1	291681	NEGATIVE JUMPER STUD, BLACK
10	1	341322	BATTERY HOLD DOWN WLD 1981
11	1	361470	BATTERY BOX WLD, 2100 98
12	1	900339	5/8UNC X 3 1/4 HEX BOLT
13	2	901150	3/8UNC X 9" CARR BOLT
14	1	900129	3/8UNC X 1" HEX BOLT
15	3	914004	3/8UNC HEX STOVER NUT
16	1	914010	5/8UNC HEX STOVER NUT

SOLUTION TANK MOUNTS AND SHIELDS

DET. QTY PART NO. DESCRIPTION

DET.	QTY	PART NO.	DESCRIPTION	
1	2	193016	QUICKEDGE TRIM .060 TO .170	
2	2	293402	HEADLIGHT ASSY, 2100	98
3	2	358958	LEG BRACE WLD, 2100	99
4	2	470100	3/8 INT TOOTH LOCK WASHER	
5	26	470118	1/4UNC X 3/4 FLANGE HEX BOLT	
6	30	470121	1/4UNC HEX FLANGE LOCK NUT	
7	2	473779	10MM-1.50 HEX NUT	
8	2	473971	1/4UNC-2"ID-3"RD U-BOLT	
9	1	659831	LWR FRONT SHIELD 280	89
10	1	659963	RH FRT TANK SHLD WLD 2100	98
11	1	659964	LH FRT TANK SHLD WLD 2100	98
12	2	659968	HEADLIGHT MT WLD, 2100	98
13	1	763476	RH FRT SOLU TNK MT WLD,2100	98
14	1	763477	LH FRT SOLU TNK MT WLD,2100	98
15	1	763478	RH REAR SOLU TNK MT WLD2100	98
16	1	763479	LH REAR SOLU TNK MT WLD2100	98
17	4	763490	SOLU TANK MT SUPP, 2100	98
18	12	900334	5/8UNC X 1 3/4 HEX BOLT	
19	8	900412	3/4UNC X 5" HEX BOLT	
20	2	910017	1" UNC HEX NUT	
21	12	914010	5/8UNC HEX STOVER NUT	
22	10	914012	3/4UNC HEX STOVER NUT	
23	4	920008	1" SAE FLAT WASHER	
24	2	920508	1" LOCK WASHER	
25	2	358961	LEG BRACE CLEVIS WLD, 2100	99
26	2	900410	3/4UNC X 4" HEX BOLT	
27	2	900814	1" UNC X 4" HEX BOLT	GR8

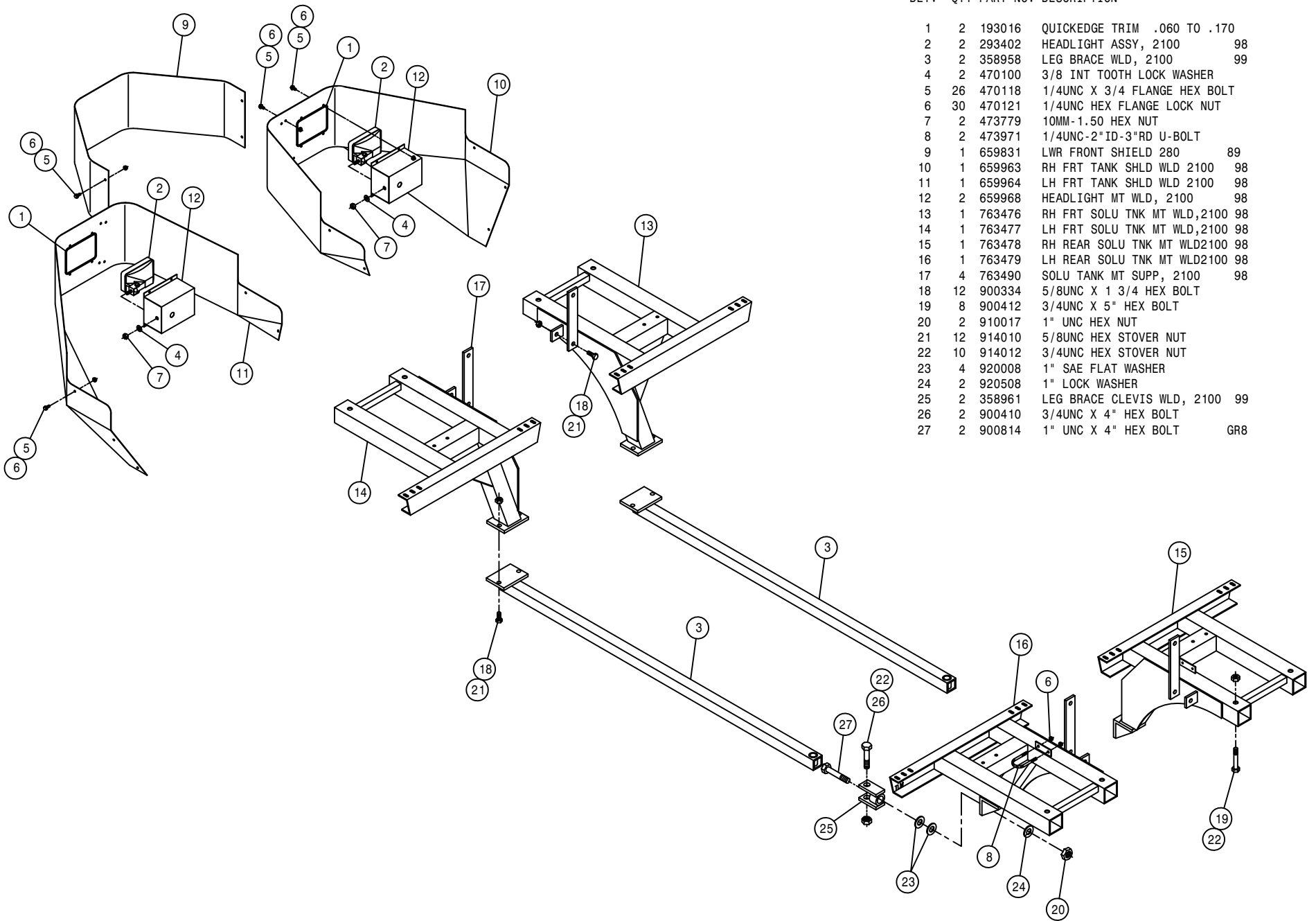

60

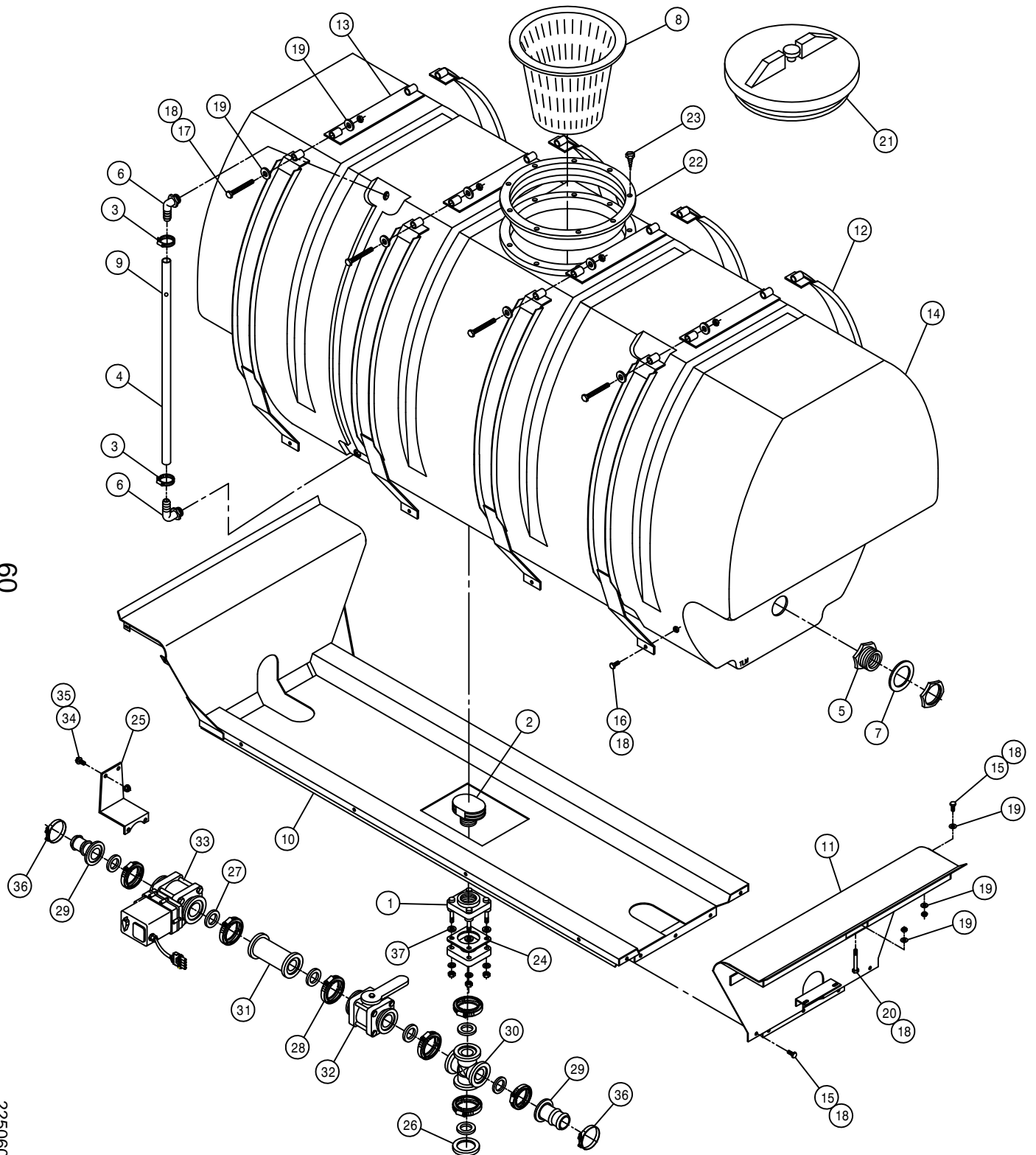

RIGHT POLY SOLUTION TANK ASSEMBLY

DET.	QTY	PART NO.	DESCRIPTION
1	1	500179	2" FLG TANK FTG, BOTDRN BLT POLY
2	1	500077	VENT CAP, 2" W/O SCREEN, POLY
3	2	520069	HOSE CLAMP NO 6 STAINLESS
4	1	601245	HOSE, 1/2 X 42 CLEAR VINYL
5	2	618548	1.25 PLASTIC FTG ASSY POLYTNK
6	2	618556	1/4NPT-90-1/2 HOSE BARB, POLY
7	2	763430	1 1/4 TANK FLANGE RUBBER SEAL
8	1	763431	8" STRAINER BASKET, SOLU TANK
9	1	763446	RED POLYPROPYLENE BALL 25/64"
10	1	763493	RH POLY TANK CRADLE WLD2100 98
11	1	763502	REAR CRADLE MT WLD, 2100 98
12	8	763507	TANK BAND WLD, 2100 POLY 98
13	4	763511	TANK BAND TIE WLD, 2100 98
14	1	763513	500 GAL POLY SOLU TANK 98
15	13	900129	3/8UNC X 1" HEX BOLT
16	8	900130	3/8UNC X 1 1/4 HEX BOLT
17	8	906138	3/8UNC X 3 1/2 HEX BOLT FULL
18	33	914004	3/8UNC HEX STOVER NUT
19	36	920002	3/8 SAE FLAT WASHER
20	4	900140	3/8UNC X 4" HEX BOLT
21	1	763408	LID, THD'D W/VENT, POLY TANK
22	1	763409	10" THD'D RING FOR TANK LID
23	8	763410	S.S. SCREW FOR CAP RING
24	1	500087	GASKET, 2" TANK FLG 500076/179
25	1	763537	ELECT SOLU VLV SUPPORT, 2100 00
26	1	500156	2" FLANGE CAP PLUG POLY
27	7	500158	1 1/2" GASKET FOR 2" FLANGE
28	7	500160	2" FLANGE CLAMP, S.S.
29	2	500162	2" FLANGE-1 1/2 HOSE BARB POLY
30	1	500176	2" FLANGE CROSS POLY
31	1	500177	2" FLANGE-2" FLANGE CPLR POLY
32	1	696142	BALL VLV, 2" FLANGE
33	1	696176	ELECT BALL VLV, 2" FLANGE BANJO
34	2	470118	1/4UNC X 3/4 FLANGE HEX BOLT
35	2	470121	1/4UNC HEX FLANGE LOCK NUT
36	2	520133	1.81/2.06 T-BOLT HOSE CLAMP SS
37	4	500100	FOOT GASKET, 2" FLG 500076/179

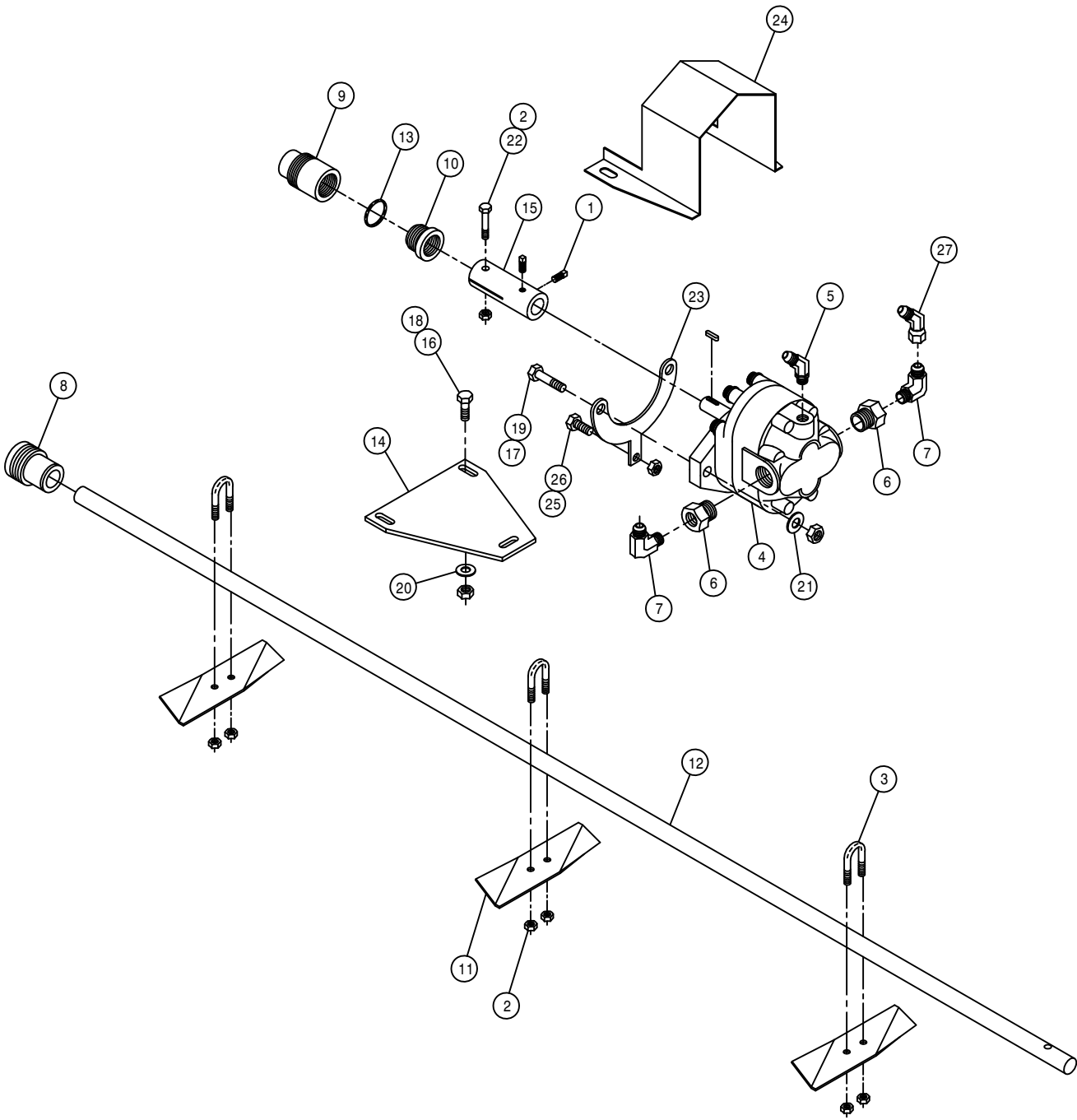

RH POLY TANK AGITATOR ASSEMBLY

DET. QTY PART NO. DESCRIPTION

1	2	470199	1/4UNC X 3/8 SQHD CUP SET SCR	
2	7	470089	1/4UNC HEX LOC NUT NYL INS SS	
3	3	470092	1/4UNC-3/4ID-1 1/4 U-BOLT SS	
4	1	610510	CESSNA GEAR MOTOR 1.48CI	
5	1	618338	9/16MJIC-45-1/4MNPT LBO	
6	2	618092	1 1/16MOR-1/2FNPT ADPTR	
7	2	618107	9/16MJIC-90-1/2MNPT LBO	
8	1	706403	FRT AGIT SHFT BRG, NYLON	
9	1	706401	REAR AGIT SHFT BRG, NYLON	
10	1	706402	AGIT SHFT GLAND NUT, NYLON	
11	3	763027	AGIT IMPELLER	
12	1	763514	AGIT SHAFT, 2100	98
13	1	763217	GLAND PACKING, 13 IN. LONG	
14	1	763357	AGIT MTR MT PLT CES 280	91
15	1	763359	AGIT MTR CPLR 280	91
16	2	900064	5/16UNC X 3/4 HEX BOLT	
17	2	900130	3/8UNC X 1 1/4 HEX BOLT	
18	2	914002	5/16UNC HEX STOVER NUT	
19	2	914004	3/8UNC HEX STOVER NUT	
20	2	920001	5/16 SAE FLAT WASHER	
21	2	920002	3/8 SAE FLAT WASHER	
22	1	470200	1/4UNC X 1 3/4 HEX BOLT SS	
23	1	763358	AGIT MTR MT YOKE CES 280	91
24	1	763361	AGIT CPLR SHIELD 280	91
25	1	900000	1/4UNC X 1/2 HEX BOLT	
26	1	914000	1/4UNC HEX STOVER NUT	
27	1	618634	9/16MJIC-45-9/16FJIC SWIV LBO	

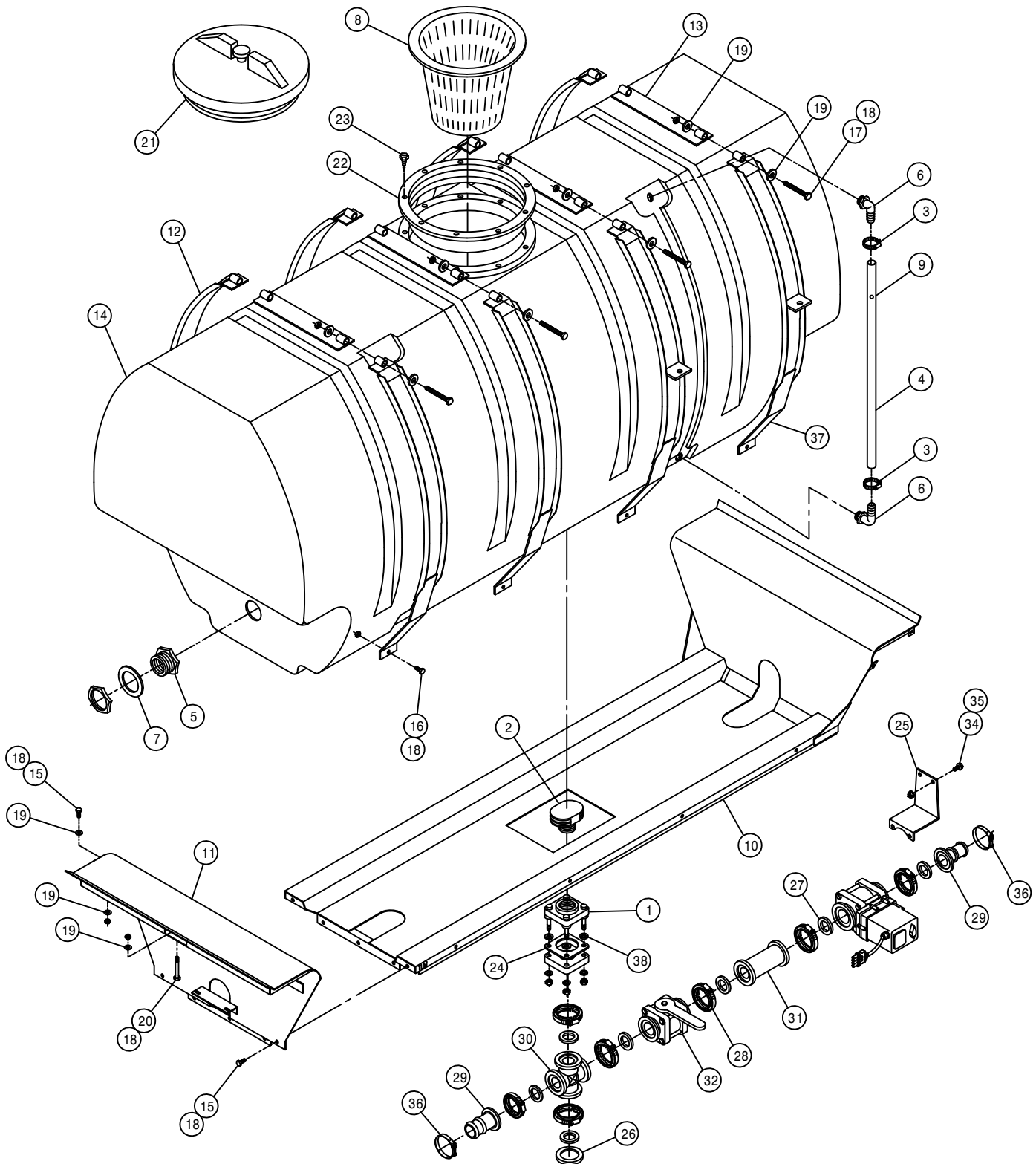

LEFT POLY SOLUTION TANK ASSEMBLY

DET.	QTY	PART NO.	DESCRIPTION
	1	500179	2" FLG TANK FTG, BOTDRN BLT POLY
	1	500077	VENT CAP, 2" W/O SCREEN, POLY
	2	520069	HOSE CLAMP NO 6 STAINLESS
	4	601245	HOSE, 1/2 X 42 CLEAR VINYL
	5	618548	1.25 PLASTIC FTG ASSY POLYTNK
	6	618556	1/4NPT-90-1/2 HOSE BARB, POLY
	7	763430	1 1/4 TANK FLANGE RUBBER SEAL
	8	763431	8" STRAINER BASKET, SOLU TANK
	9	763446	RED POLYPROPYLENE BALL 25/64"
	10	763494	LH POLY TANK CRADLE WLD2100 98
	11	763502	REAR CRADLE MT WLD, 2100 98
	12	763507	TANK BAND WLD, 2100 POLY 98
	13	763511	TANK BAND TIE WLD, 2100 98
	14	763513	500 GAL POLY SOLU TANK 98
	15	900129	3/8UNC X 1" HEX BOLT
	16	900130	3/8UNC X 1 1/4 HEX BOLT
	17	906138	3/8UNC X 3 1/2 HEX BOLT FULL
	18	914004	3/8UNC HEX STOVER NUT
	36	920002	3/8 SAE FLAT WASHER
	20	900140	3/8UNC X 4" HEX BOLT
	21	763408	LID, THD'D W/VENT, POLY TANK
	22	763409	10" THD'D RING FOR TANK LID
	23	763410	S.S. SCREW FOR CAP RING
	24	500087	GASKET, 2" TANK FLG 500076/179
	25	763537	ELECT SOLU VLV SUPPORT, 2100 00
	26	500156	2" FLANGE CAP PLUG POLY
	27	500158	1 1/2" GASKET FOR 2" FLANGE
	28	500160	2" FLANGE CLAMP, S.S.
	29	500162	2" FLANGE-1 1/2 HOSE BARB POLY
	30	500176	2" FLANGE CROSS POLY
	31	500177	2" FLANGE-2" FLANGE CPLR POLY
	32	696142	BALL VLV, 2" FLANGE
	33	696176	ELECT BALL VLV, 2" FLANGE BANJO
	34	470118	1/4UNC X 3/4 FLANGE HEX BOLT
	35	470121	1/4UNC HEX FLANGE LOCK NUT
	36	520133	1.81/2.06 T-BOLT HOSE CLAMP SS
	37	763515	TANK BAND W/TAB WLD, 2100 98
	38	500100	FOOT GASKET, 2" FLG 500076/179

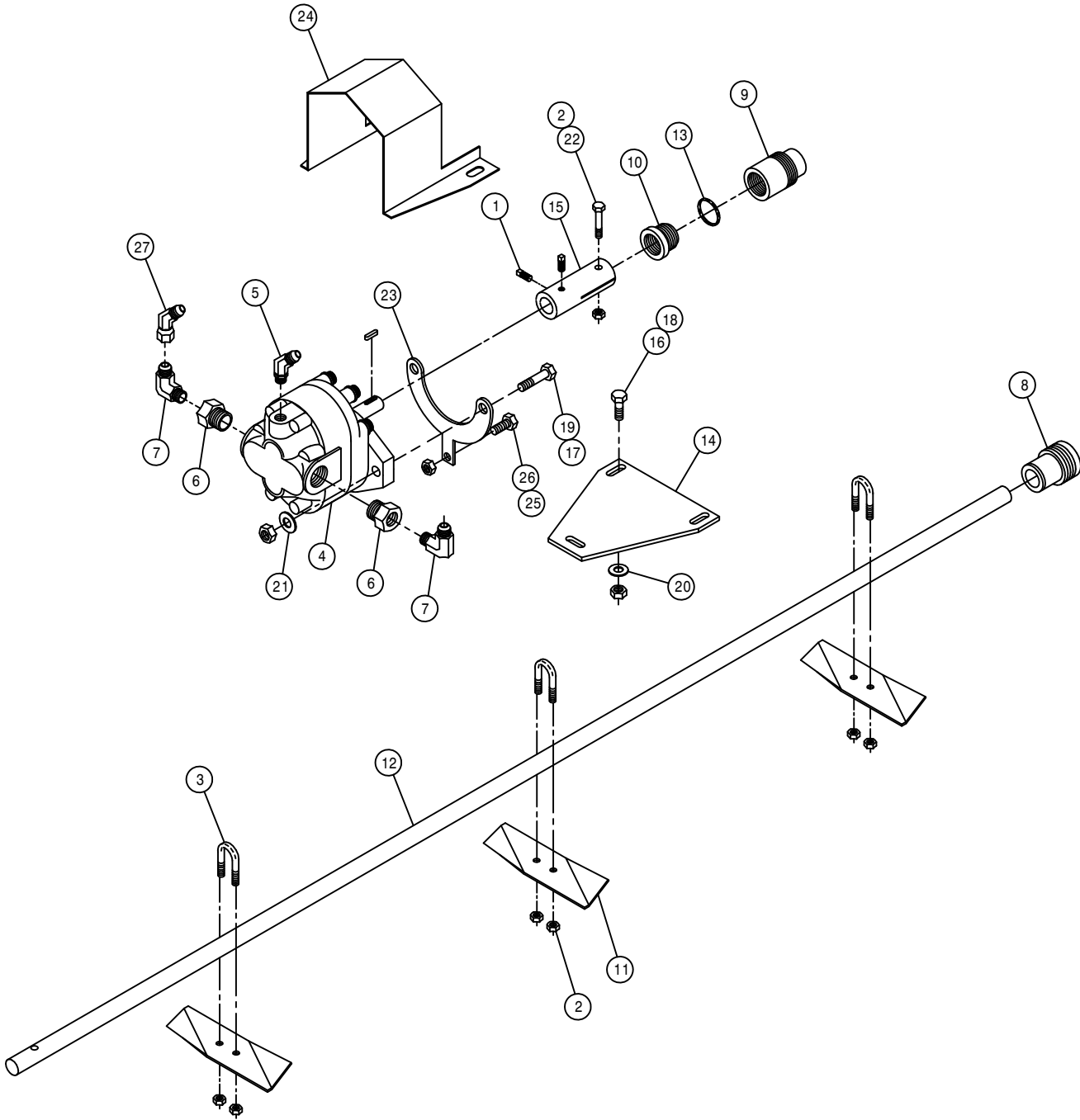

LH POLY TANK AGITATOR ASSEMBLY

DET.	QTY	PART NO.	DESCRIPTION	
1	2	470199	1/4UNC X 3/8 SQHD CUP SET SCR	
2	7	470089	1/4UNC HEX LOC NUT NYL INS SS	
3	3	470092	1/4UNC-3/4ID-1 1/4 U-BOLT SS	
4	1	610510	CESSNA GEAR MOTOR 1.48CI	
5	1	618338	9/16MJIC-45-1/4MNPT LBO	
6	2	618092	1 1/16MOR-1/2FNPT ADPTR	
7	2	618107	9/16MJIC-90-1/2MNPT LBO	
8	1	706403	FRT AGIT SHFT BRG, NYLON	
9	1	706401	REAR AGIT SHFT BRG, NYLON	
10	1	706402	AGIT SHFT GLAND NUT, NYLON	
11	3	763027	AGIT IMPELLER	
12	1	763514	AGIT SHAFT, 2100	98
13	1	763217	GLAND PACKING, 13 IN. LONG	
14	1	763357	AGIT MTR MT PLT CES 280	91
15	1	763359	AGIT MTR CPLR 280	91
16	2	900064	5/16UNC X 3/4 HEX BOLT	
17	2	900130	3/8UNC X 1 1/4 HEX BOLT	
18	2	914002	5/16UNC HEX STOVER NUT	
19	2	914004	3/8UNC HEX STOVER NUT	
20	2	920001	5/16 SAE FLAT WASHER	
21	2	920002	3/8 SAE FLAT WASHER	
22	1	470200	1/4UNC X 1 3/4 HEX BOLT SS	
23	1	763358	AGIT MTR MT YOKE CES 280	91
24	1	763361	AGIT CPLR SHIELD 280	91
25	1	900000	1/4UNC X 1/2 HEX BOLT	
26	1	914000	1/4UNC HEX STOVER NUT	
27	1	618634	9/16MJIC-45-9/16FJIC SWIV LBO	

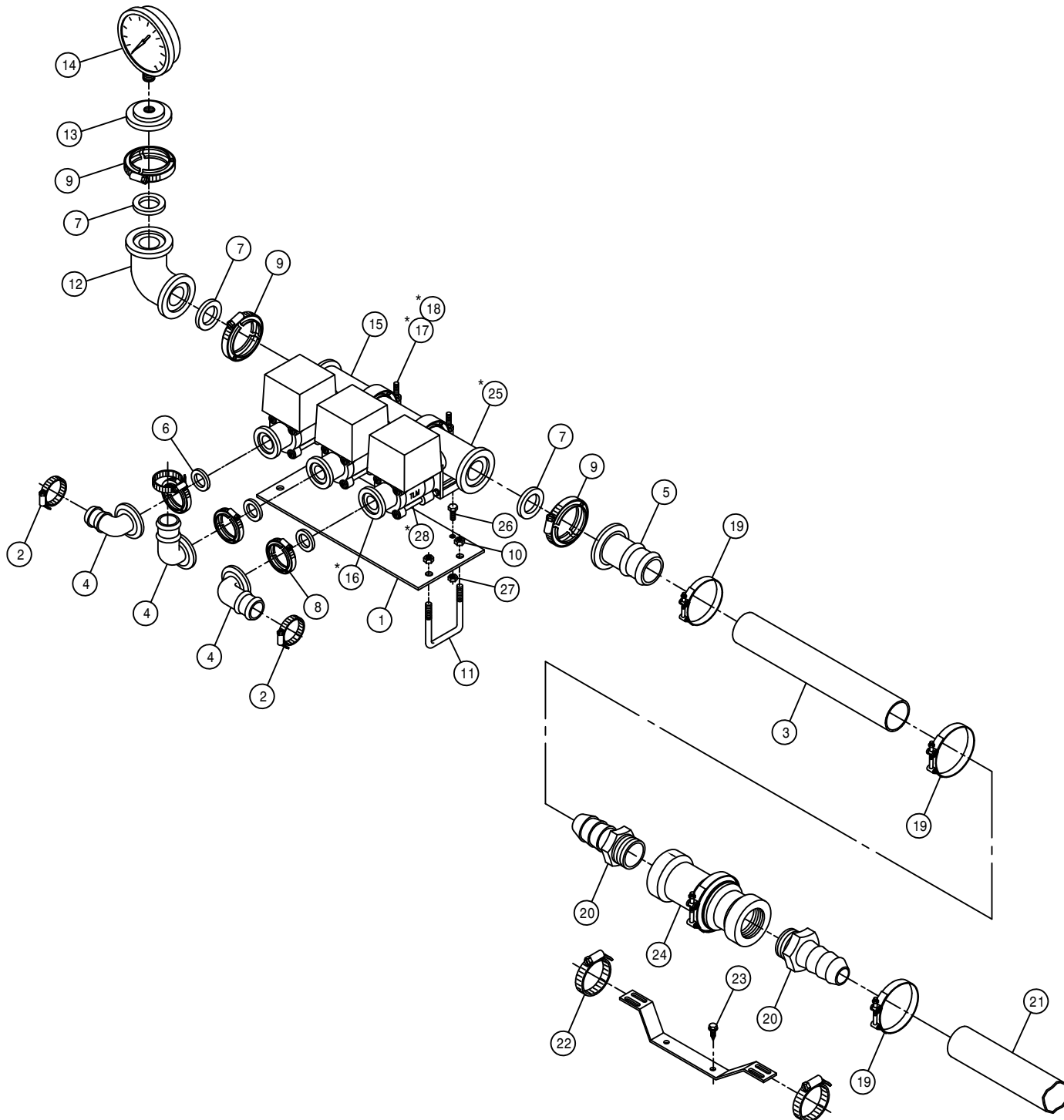

60' SOLUTION SOLENOID ASSEMBLY (STANDARD)

DET.	QTY	PART NO.	DESCRIPTION
1	1	164422	SOLU MANIF VLV MT, HIVOL
2	3	520090	HOSE CLAMP NO 16 STAINLESS
3	1	601451	HOSE, 2 X 69 2F-1W EPDM
4	3	500173	1" FLANGE-90-1" HOSE BARB POLY
5	1	500154	2" FLANGE-2" HOSE BARB POLY
6	3	500157	1" FLANGE GASKET EPDM
7	3	500158	1 1/2" GASKET FOR 2" FLANGE
8	3	500159	1" FLANGE CLAMP, S.S.
9	3	500160	2" FLANGE CLAMP, S.S.
10	4	914004	3/8UNC HEX STOVER NUT
11	2	470136	3/8UNC-3 1/16ID-3 SQ U-BOLT
12	1	500180	2"FLANGE-90-2"FLANGE LBO POLY
13	1	500181	2" FLANGE PLUG W/1/4"FNPT POLY
14	1	690359	PRESSURE GA GLYCERI 100 PSI
15	1	696178	ELECT 3-BALL VLV,2"FLANGE TJET
16	3	696502	OUTLET FLG END-CAP FOR 696178
17	2	696503	O-RING,VLV FITTING FOR 696178
18	2	696504	CLAMP,VLV FITTING FOR 696178
19	3	520141	2.31/2.62 T-BOLT HOSE CLAMP SS
20	2	500058	2"NPT X 2" H BARB, POLY
21	1	601450	HOSE, 2 X 84 2F-1W EPDM
22	2	520056	HOSE CLAMP NO 56 STAINLESS
23	2	472349	1/4 X 3/4 20THD-IN TEK TYPE
24	1	690529	RFW 100 FLOW METER, RAVEN
25	3	696501	FLANGE VLV TEE FOR 696178
26	3	900064	5/16UNC X 3/4 HEX BOLT
27	3	914002	5/16UNC HEX STOVER NUT
28	3	696500	450EC VLV W/FLG TEE FOR 696178

NOTE: ITEMS MARKED WITH A (\*) ARE SOLUTION VALVE REPAIR PARTS.



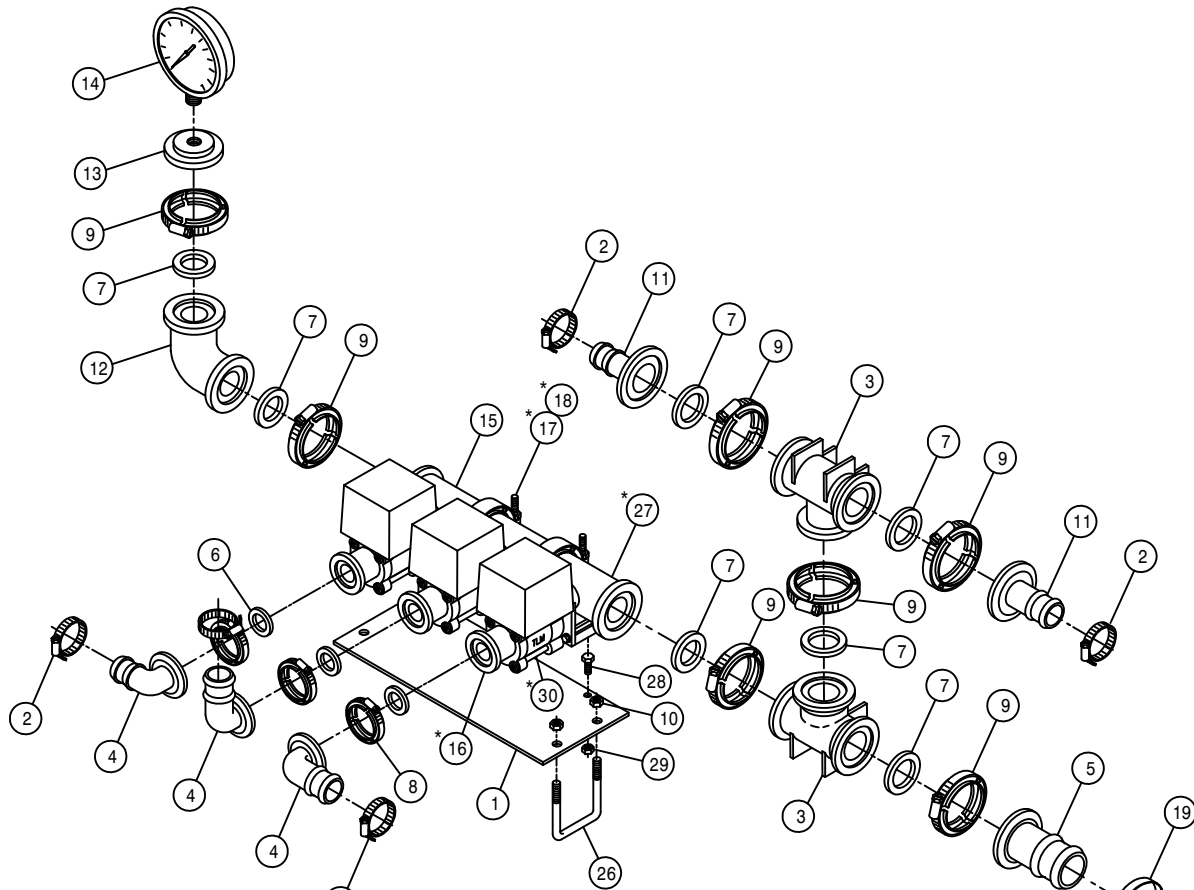

80'-90' SOLUTION SOLENOID ASSEMBLY (STANDARD)

DET. QTY PART NO. DESCRIPTION

DET.	QTY	PART NO.	DESCRIPTION
1	1	164422	SOLU MANIF VLV MT, HIVOL
2	5	520090	HOSE CLAMP NO 16 STAINLESS
3	2	500151	2" FLANGE TEE POLY
4	3	500173	1" FLANGE-90-1" HOSE BARB POLY
5	1	500154	2" FLANGE-2" HOSE BARB POLY
6	3	500157	1" FLANGE GASKET EPDM
7	7	500158	1 1/2" GASKET FOR 2" FLANGE
8	3	500159	1" FLANGE CLAMP, S.S.
9	7	500160	2" FLANGE CLAMP, S.S.
10	4	914004	3/8UNC HEX STOVER NUT
11	2	500172	2" FLANGE-1" HOSE BARB POLY
12	1	500180	2" FLANGE-90-2" FLANGE LBO POLY
13	1	500181	2" FLANGE PLUG W/1/4" FNPT POLY
14	1	690359	PRESSURE GA GLYCERI 100 PSI
15	1	696178	ELECT 3-BALL VLV, 2" FLANGE TJET
16	3	696502	OUTLET FLG END-CAP FOR 696178
17	2	696503	O-RING, VLV FITTING FOR 696178
18	2	696504	CLAMP, VLV FITTING FOR 696178
19	3	520141	2.31/2.62 T-BOLT HOSE CLAMP SS
20	2	500058	2" NPT X 2" H BARB, POLY
21	1	601450	HOSE, 2 X 84 2F-1W EPDM
22	2	520056	HOSE CLAMP NO 56 STAINLESS
23	2	472349	1/4 X 3/4 20THD-IN TEK TYPE
24	1	690529	RFM 100 FLOW METER, RAVEN
25	1	601451	HOSE, 2 X 69 2F-1W EPDM
26	2	470136	3/8UNC-3 1/16ID-3 SQ U-BOLT
27	3	696501	FLANGE VLV TEE FOR 696178
28	3	900064	5/16UNC X 3/4 HEX BOLT
29	3	914002	5/16UNC HEX STOVER NUT
30	1	696500	450EC VLV W/FLG TEE FOR 696178

NOTE: ITEMS MARKED WITH A (\*) ARE SOLUTION VALVE REPAIR PARTS.

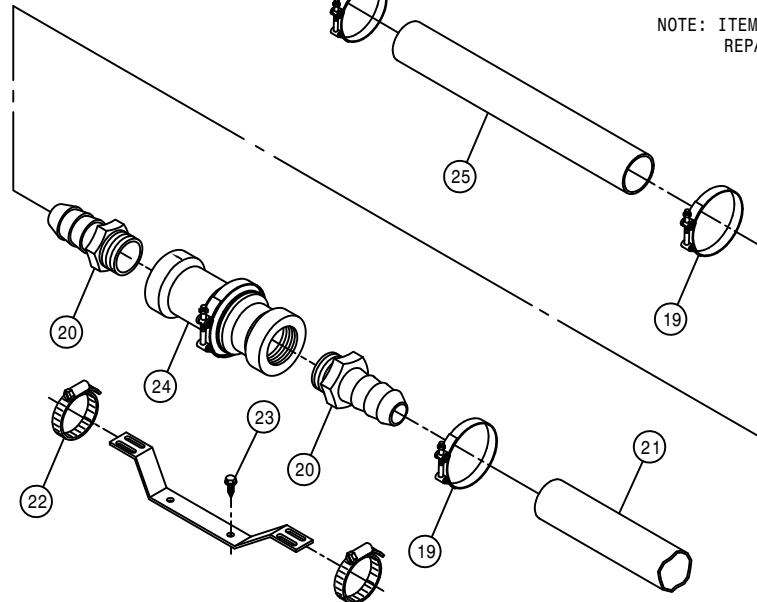

80'-90' OUTER BOOM SOLENOID (STANDARD)

DET. QTY PART NO. DESCRIPTION

1	1	164303	SOLU VLV MT	97
2	1	164304	SOLU VLV MT KEEPER	97
3	1	500043	3/4NPT PIPE PLUG, POLY	
4	1	500047	1/2NPT-90-1/2 HOSE BARB, POLY	
5	1	500085	1" X 3/4NPT REDU NIPPLE, POLY	
6	4	500157	1" FLANGE GASKET	EPDM
7	4	500159	1" FLANGE CLAMP, S.S.	
8	1	500168	1" FLANGE-1" FNPT ADPTR	POLY
9	1	500171	1" FLANGE-1" HOSE BARB	POLY
10	1	500173	1" FLANGE-90-1" HOSE BARB POLY	
11	1	695952	SOLUTION VALVE, AA144-1 VITON	
12	1	696177	ELECT BALL VLV, 1" FLANGE	TJET
13	2	900007	1/4UNC X 2" HEX BOLT	
14	2	914000	1/4UNC HEX STOVER NUT	
15	2	520090	HOSE CLAMP NO 16 STAINLESS	
16	1	500175	1" FLANGE TEE	POLY

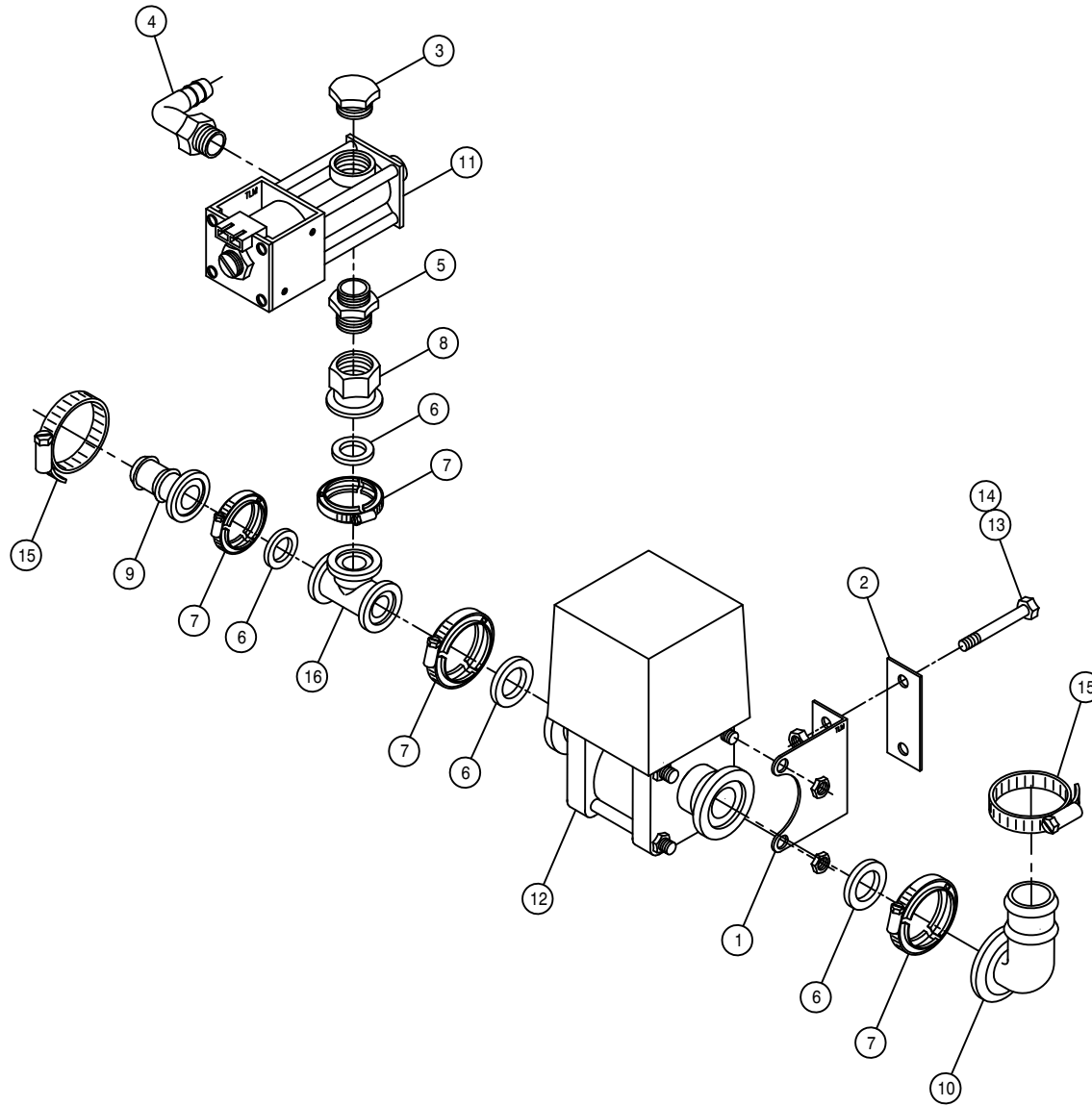

60' SOLUTION ASSEMBLY (HI-VOLUME)

DET. QTY PART NO. DESCRIPTION

DET.	QTY	PART NO.	DESCRIPTION
1	1	164422	SOLU MANIF VLV MT, HIVOL
2	3	520067	HOSE CLAMP NO 28 STAINLESS
3	2	470136	3/8UNC-3 1/16ID-3 SQ U-BOLT
4	3	500153	2" FLANGE-90-1 1/2 HBARB POLY
5	1	500154	2" FLANGE-2" HOSE BARB POLY
6	3	500157	1" FLANGE GASKET EPDM
7	6	500158	1 1/2" GASKET FOR 2" FLANGE
8	3	500159	1" FLANGE CLAMP, S.S.
9	6	500160	2" FLANGE CLAMP, S.S.
10	3	500161	2"FLANGE-1"FLANGE COUPLER,POLY
11	4	914004	3/8UNC HEX STOVER NUT
12	1	500180	2"FLANGE-90-2"FLANGE LBO POLY
13	1	500181	2" FLANGE PLUG W/1/4"FNPT POLY
14	1	690359	PRESSURE GA GLYCERI 100 PSI
15	1	696178	ELECT 3-BALL VLV,2"FLANGE TJET
16	3	696502	OUTLET FLG END-CAP FOR 696178
17	2	696503	O-RING,VLV FITTING FOR 696178
18	2	696504	CLAMP,VLV FITTING FOR 696178
19	3	520141	2.31/2.62 T-BOLT HOSE CLAMP SS
20	2	500058	2"NPT X 2" H BARB, POLY
21	1	601450	HOSE, 2 X 84 2F-1W EPDM
22	2	520056	HOSE CLAMP NO 56 STAINLESS
23	2	472349	1/4 X 3/4 20THD-IN TEK TYPE
24	1	690529	RFM 100 FLOW METER, RAVEN
25	1	601451	HOSE, 2 X 69 2F-1W EPDM
26	3	696501	FLANGE VLV TEE FOR 696178
27	3	900064	5/16UNC X 3/4 HEX BOLT
28	3	914002	5/16UNC HEX STOVER NUT
29	3	696500	450EC VLV W/FLG TEE FOR 696178

NOTE: ITEMS MARKED WITH A (\*) ARE SOLUTION VALVE REPAIR PARTS.

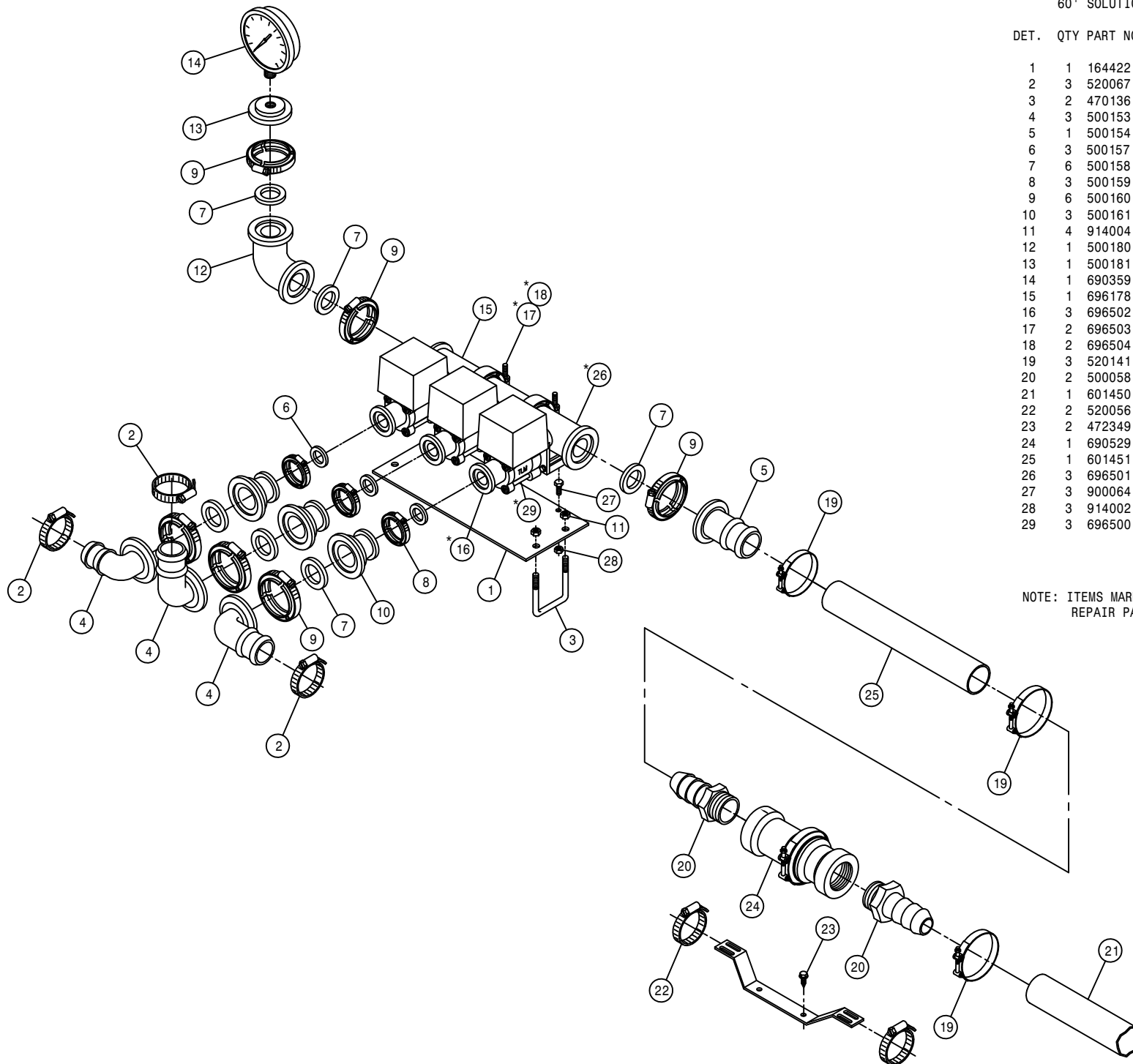

80' -90' SOLUTION SOLENOID ASSEMBLY (HI-VOLUME)

DET. QTY PART NO. DESCRIPTION

DET.	QTY	PART NO.	DESCRIPTION
1	1	164422	SOLU MANIF VLV MT, HIVOL
2	5	520067	HOSE CLAMP NO 28 STAINLESS
3	2	500151	2" FLANGE TEE POLY
4	3	500153	2" FLANGE-90-1 1/2 HBARB POLY
5	1	500154	2" FLANGE-2" HOSE BARB POLY
6	3	500157	1" FLANGE GASKET EPDM
7	10	500158	1 1/2" GASKET FOR 2" FLANGE
8	3	500159	1" FLANGE CLAMP, S.S.
9	10	500160	2" FLANGE CLAMP, S.S.
10	3	500161	2" FLANGE-1" FLANGE COUPLER, POLY
11	2	500162	2" FLANGE-1 1/2 HOSE BARB POLY
12	1	500180	2" FLANGE-90-2" FLANGE LBO POLY
13	1	500181	2" FLANGE PLUG W/1/4" FNPT POLY
14	1	690359	PRESSURE GA GLYCERI 100 PSI
15	1	696178	ELECT 3-BALL VLV, 2" FLANGE TJET
16	3	696502	OUTLET FLG END-CAP FOR 696178
17	2	696503	O-RING, VLV FITTING FOR 696178
18	2	696504	CLAMP, VLV FITTING FOR 696178
19	3	520141	2.31/2.62 T-BOLT HOSE CLAMP SS
20	2	500058	2"NPT X 2" H BARB, POLY
21	1	601450	HOSE, 2 X 84 2F-1W EPDM
22	2	520056	HOSE CLAMP NO 56 STAINLESS
23	2	472349	1/4 X 3/4 20THD-IN TEK TYPE
24	1	690529	RFM 100 FLOW METER, RAVEN
25	1	601451	HOSE, 2 X 69 2F-1W EPDM
26	2	470136	3/8UNC-3 1/16ID-3 SQ U-BOLT
27	4	914004	3/8UNC HEX STOVER NUT
28	3	696501	FLANGE VLV TEE FOR 696178
29	3	900064	5/16UNC X 3/4 HEX BOLT
30	3	914002	5/16UNC HEX STOVER NUT
31	3	696500	450EC VLV W/FLG TEE FOR 696178

NOTE: ITEMS MARKED WITH A (\*) ARE SOLUTION VALVE REPAIR PARTS.

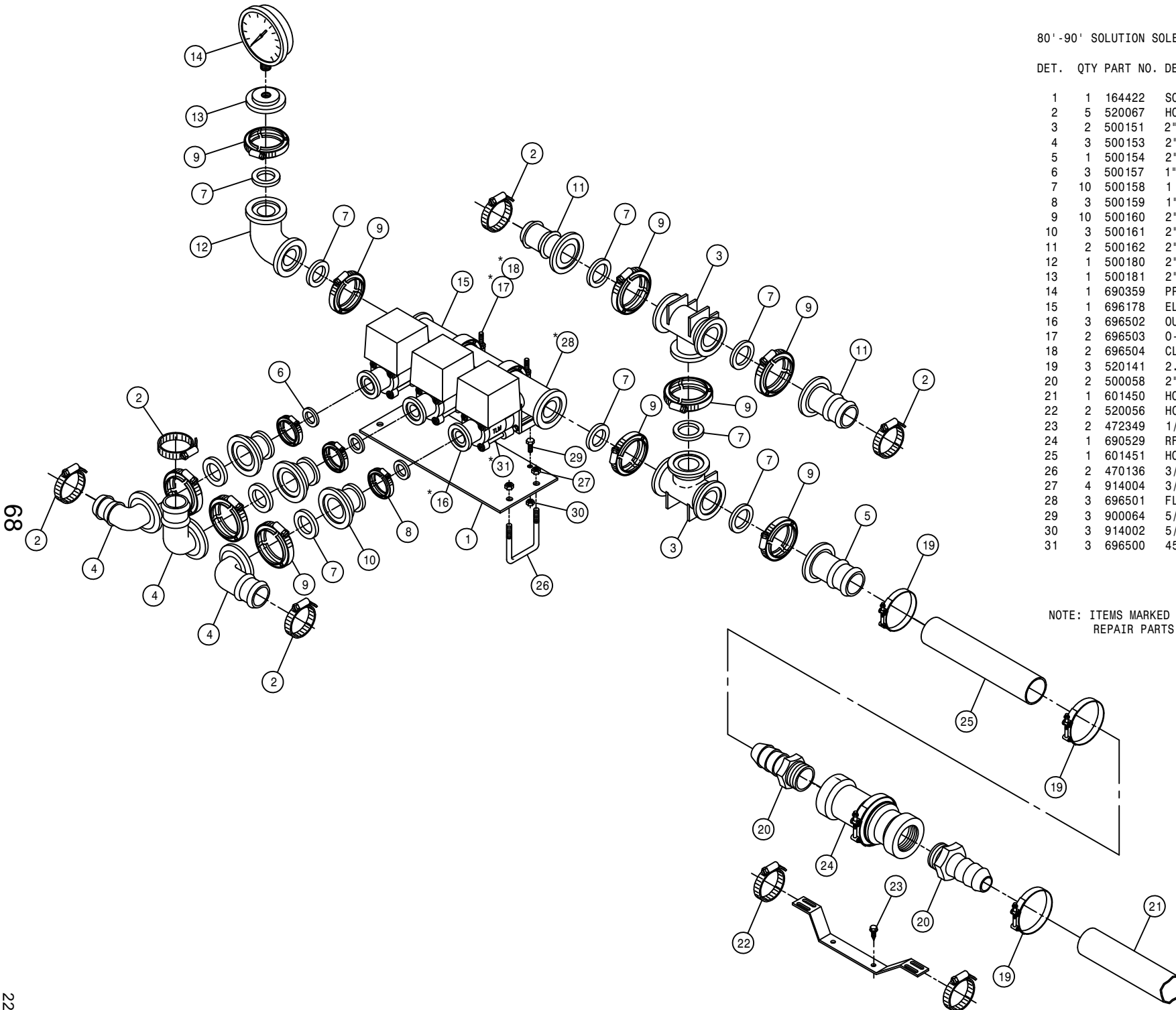

68

80'-90' OUTER BOOM SOLENOID (HI-VOLUME)

DET. QTY PART NO. DESCRIPTION

1	1	164303	SOLU VLV MT	97
2	1	164304	SOLU VLV MT KEEPER	97
3	1	500043	3/4NPT PIPE PLUG, POLY	
4	1	500047	1/2NPT-90-1/2 HOSE BARB, POLY	
5	1	500085	1" X 3/4NPT REDU NIPPLE, POLY	
6	4	500157	1" FLANGE GASKET	EPDM
7	4	500159	1" FLANGE CLAMP, S.S.	
8	1	500168	1" FLANGE-1" FNPT ADPTR	POLY
9	1	500162	2" FLANGE-1 1/2 HOSE BARB	POLY
10	1	500153	2" FLANGE-90-1 1/2 HBARB	POLY
11	1	695952	SOLUTION VALVE, AA144-1	VITON
12	1	696177	ELECT BALL VLV, 1" FLANGE	TJET
13	2	900007	1/4UNC X 2" HEX BOLT	
14	2	914000	1/4UNC HEX STOVER NUT	
15	3	520133	1.81/2.06 T-BOLT HOSE CLAMP SS	
16	1	500175	1" FLANGE TEE	POLY
17	2	500158	1 1/2" GASKET FOR 2" FLANGE	
18	2	500160	2" FLANGE CLAMP, S.S.	
19	2	500161	2" FLANGE-1" FLANGE COUPLER, POLY	
20	1	473974	.31UNC-2.56ID-3.5 U-BOLT SS	
21	1	164199	HIGH VOLUME HOSE SWIVEL MT	
22	1	500032	1 1/2NPT X 1 1/2 H BARB, POLY	
23	1	500066	1 1/2NPT-90-1 1/2 H BARB POLY	
24	1	500082	1 1/2NPT-90 EL, POLY	
25	1	500101	1 1/2" NPT SWIVEL	POLY
26	2	900064	5/16UNC X 3/4 HEX BOLT	
27	4	910002	5/16UNC HEX NUT	
28	2	914002	5/16UNC HEX STOVER NUT	
29	2	520067	HOSE CLAMP NO 28 STAINLESS	

NOTE: DETAIL 15 IS USED WITH 1 1/2 I.D.  
2F-1W EPDM HOSE.

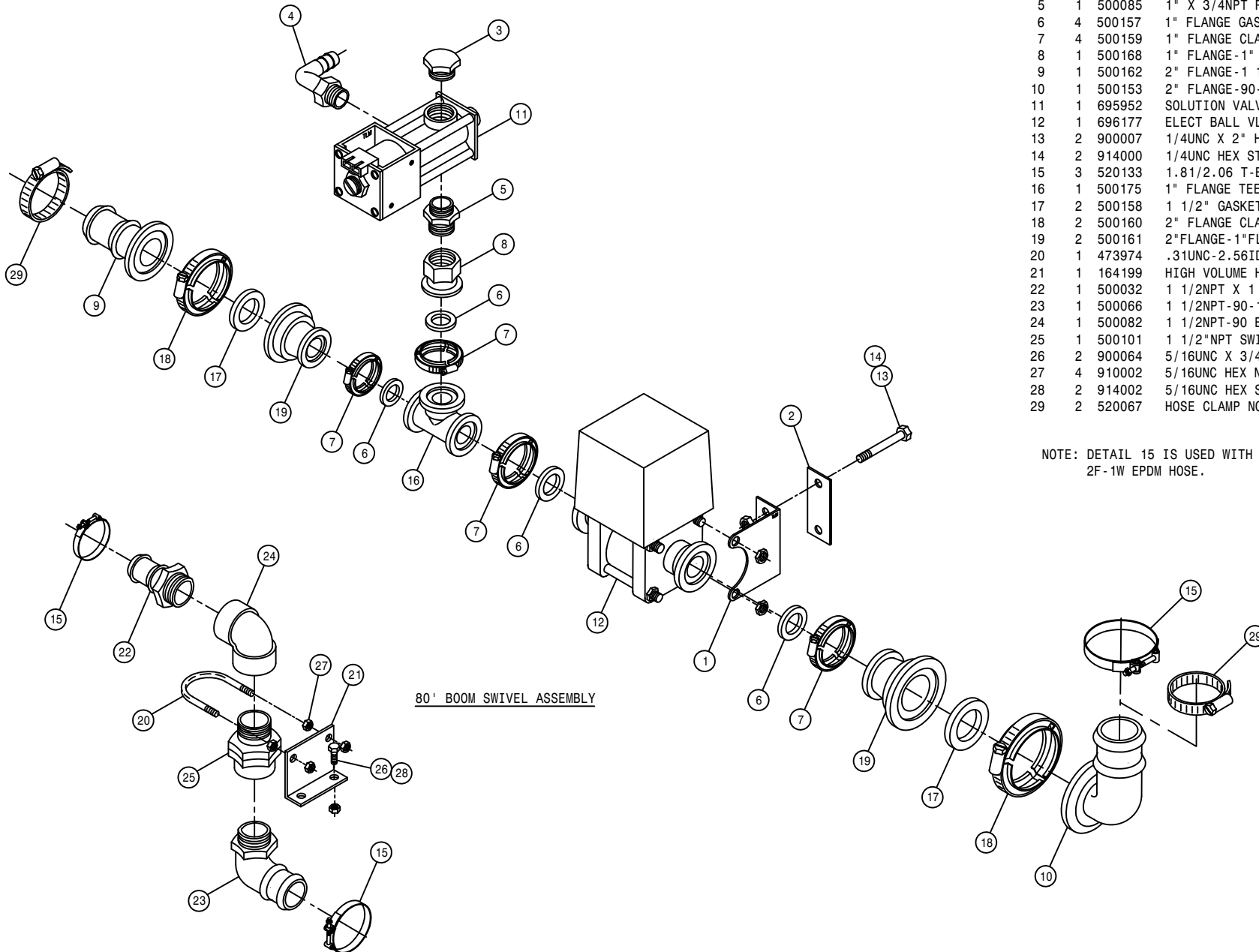

80' BOOM SWIVEL ASSEMBLY

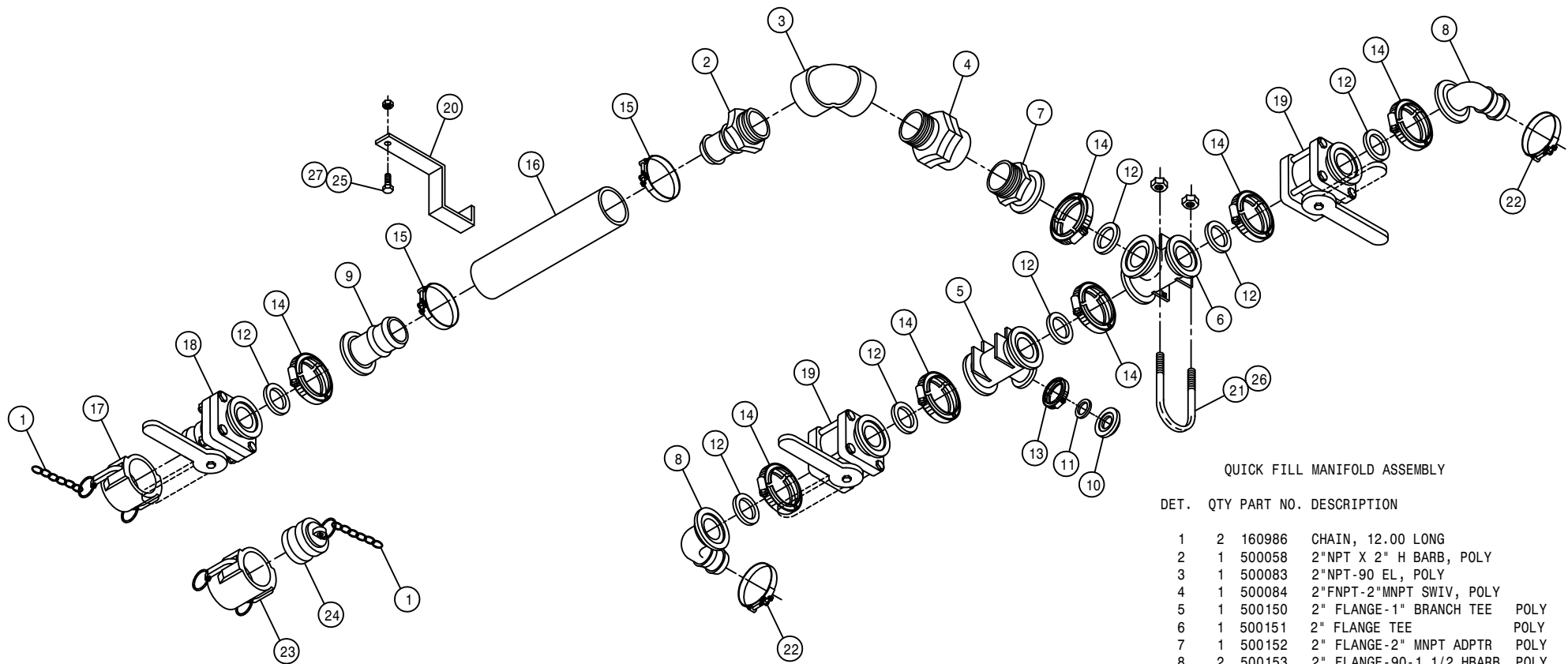

QUICK FILL MANIFOLD ASSEMBLY

DET.	QTY	PART NO.	DESCRIPTION
1	2	160986	CHAIN, 12.00 LONG
2	1	500058	2"NPT X 2" H BARB, POLY
3	1	500083	2"NPT-90 EL, POLY
4	1	500084	2"FNPT-2"MNPT SWIV, POLY
5	1	500150	2" FLANGE-1" BRANCH TEE POLY
6	1	500151	2" FLANGE TEE POLY
7	1	500152	2" FLANGE-2" MNPT ADPTR POLY
8	2	500153	2" FLANGE-90-1 1/2 HBARB POLY
9	1	500154	2" FLANGE-2" HOSE BARB POLY
10	1	500155	1" FLANGE CAP PLUG POLY
11	1	500157	1" FLANGE GASKET EPDM
12	7	500158	1 1/2" GASKET FOR 2" FLANGE
13	1	500159	1" FLANGE CLAMP, S.S.
14	7	500160	2" FLANGE CLAMP, S.S.
15	2	520141	2.31/2.62 T-BOLT HOSE CLAMP SS
16	1	601423	HOSE, 2 X 12 2F-1W EPDM
17	1	690623	CAP FOR 2.00 MALE COUPLER POLY
18	1	696141	BALL VLV,2"FLANGE/2"MALE ADPTR
19	2	696142	BALL VLV, 2" FLANGE
20	1	342620	QUICK FILL HOSE HANGER
21	2	472195	5/16UNC-2 11/16ID-3 9/16U-BOLT
22	2	520133	1.81/2.06 T-BOLT HOSE CLAMP SS
23	1	690390	2.00FNPT-FEMALE COUPLER POLY
24	1	690392	PLUG FOR 2.00 FEMALE COUPLER
25	1	900129	3/8UNC X 1" HEX BOLT
26	4	914002	5/16UNC HEX STOVER NUT
27	1	914004	3/8UNC HEX STOVER NUT

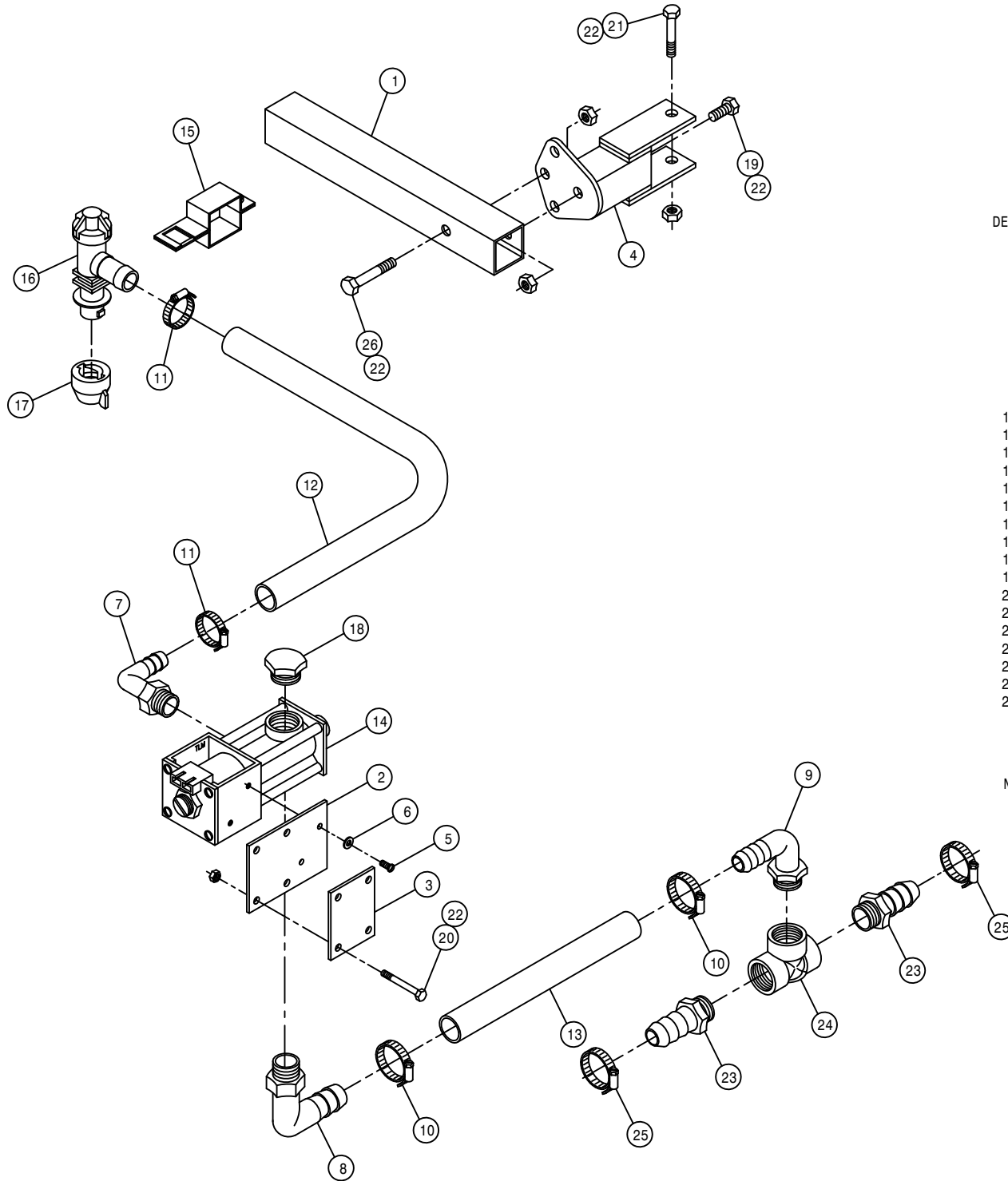

60' BOOM FENCE ROW (STANDARD)

DET. QTY PART NO. DESCRIPTION

1	2	164384	FENCE ROW NOZL MTG TUBE	98
2	2	164397	VLV MT, 60' FENCE ROW NOZL	98
3	2	164398	VLV MT KPR,60' FENCE ROW NOZL	98
4	2	164399	NOZL MT WLD,60' FENCE ROW	210098
5	4	472199	10-24 X 1/2 RD HD MACH SCR	
6	4	473821	#10 INT TOOTH WASHER	
7	2	500047	1/2NPT-90-1/2 HOSE BARB, POLY	
8	2	500054	3/4NPT-90-3/4 HOSE BARB, POLY	
9	2	500067	1 NPT-90-3/4 HOSE BARB, POLY	
10	4	520055	HOSE CLAMP NO 12 STAINLESS	
11	4	520070	HOSE CLAMP NO 8 STAINLESS	
12	1	601432	HOSE, 1/2 X 130 1BR BLK EPDM	
13	2	601173	HOSE, 3/4 X 50 1BR BLK EPDM	
14	2	695952	SOLUTION VALVE, AA144-1 VITON	
15	2	737817	NOZL MT CLMP,1.00 SQ SS,Q-TJET	
16	2	737827	QUICK TEEJET CHK VLV 1/2 SNGL	
17	2	737822	CAP SET, YELLOW QUICK TEEJET	
18	2	500043	3/4NPT PIPE PLUG, POLY	
19	2	900002	1/4UNC X 3/4 HEX BOLT	
20	8	900006	1/4UNC X 1 3/4 HEX BOLT	
21	2	900007	1/4UNC X 2" HEX BOLT	
22	14	914000	1/4UNC HEX STOVER NUT	
23	4	500074	1"NPT-1" HOSE BARB, POLY	
24	2	500075	1" NPT PIPE TEE, POLY	
25	4	520090	HOSE CLAMP NO 16 STAINLESS	
26	2	900005	1/4UNC X 1 1/2 HEX BOLT	

NOTE: QUANTITY LISTED IS FOR ONE MACHINE.

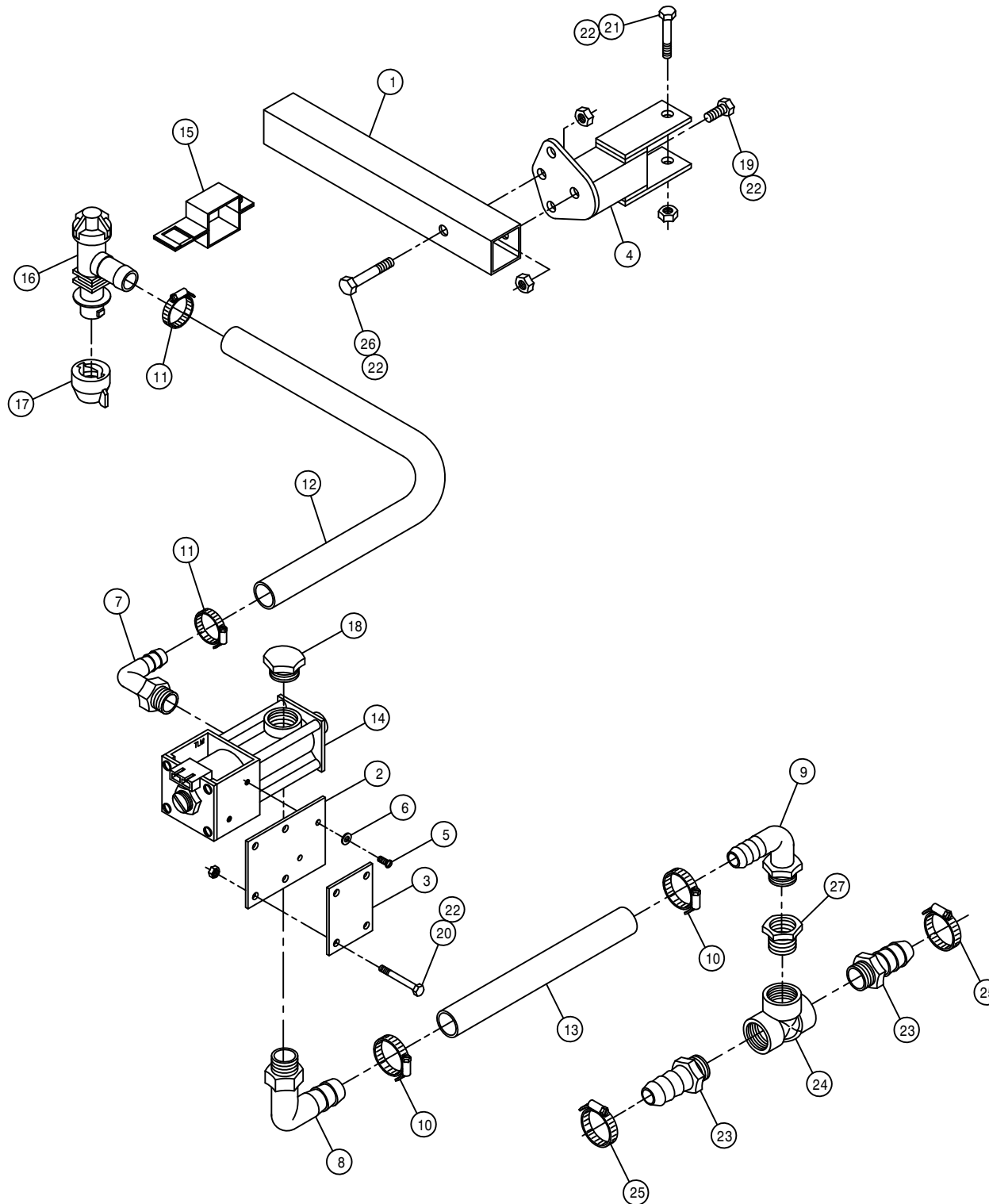

60' BOOM FENCE ROW (HI-VOLUME)

DET. QTY PART NO. DESCRIPTION

1	2	164384	FENCE ROW NOZL MTG TUBE	98
2	2	164397	VLV MT, 60' FENCE ROW NOZL	98
3	2	164398	VLV MT KPR,60' FENCE ROW NOZL	98
4	2	164399	NOZL MT WLD,60' FENCE ROW	210098
5	4	472199	10-24 X 1/2 RD HD MACH SCR	
6	4	473821	#10 INT TOOTH WASHER	
7	2	500047	1/2NPT-90-1/2 HOSE BARB, POLY	
8	2	500054	3/4NPT-90-3/4 HOSE BARB, POLY	
9	2	500067	1 NPT-90-3/4 HOSE BARB, POLY	
10	4	520055	HOSE CLAMP NO 12 STAINLESS	
11	4	520070	HOSE CLAMP NO 8 STAINLESS	
12	2	601432	HOSE, 1/2 X 130 1BR BLK EPDM	
13	2	601173	HOSE, 3/4 X 50 1BR BLK EPDM	
14	2	695952	SOLUTION VALVE, AA144-1 VITON	
15	2	737817	NOZL MT CLMP,1.00 SQ SS,Q-TJET	
16	2	737827	QUICK TEEJET CHK VLV 1/2 SNGL	
17	2	737822	CAP SET, YELLOW QUICK TEEJET	
18	2	500043	3/4NPT PIPE PLUG, POLY	
19	2	900002	1/4UNC X 3/4 HEX BOLT	
20	8	900006	1/4UNC X 1 3/4 HEX BOLT	
21	2	900007	1/4UNC X 2" HEX BOLT	
22	14	914000	1/4UNC HEX STOVER NUT	
23	4	500032	1 1/2NPT X 1 1/2 H BARB, POLY	
24	2	500030	1 1/2"NPT PIPE TEE, POLY	
25	4	520067	HOSE CLAMP NO 28 STAINLESS	
26	2	900005	1/4UNC X 1 1/2 HEX BOLT	
27	2	500036	1 1/2"X 1"NPT REDU BUSH, POLY	

NOTE: QUANTITY LISTED IS FOR ONE MACHINE.



80' -90' BOOM FENCE ROW

DET. QTY PART NO. DESCRIPTION

1	6	914000	1/4UNC HEX STOVER NUT
2	2	164380	NOZL MT WLD,80/90 FENCE ROW 98
3	2	164384	FENCE ROW NOZL MTG TUBE 98
4	2	737827	QUICK TEEJET CHK VLV 1/2 SNGL
5	2	737822	CAP SET, YELLOW QUICK TEEJET
6	2	900002	1/4UNC X 3/4 HEX BOLT
7	2	900006	1/4UNC X 1 3/4 HEX BOLT
8	2	900005	1/4UNC X 1 1/2 HEX BOLT
9	4	520070	HOSE CLAMP NO 8 STAINLESS
10	2	601167	HOSE, 1/2 X 300 1BR BLK EPDM
11	2	737817	NOZL MT CLMP,1.00 SQ SS,Q-TJET

NOTE: QUANTITY LISTED IS FOR ONE MACHINE.

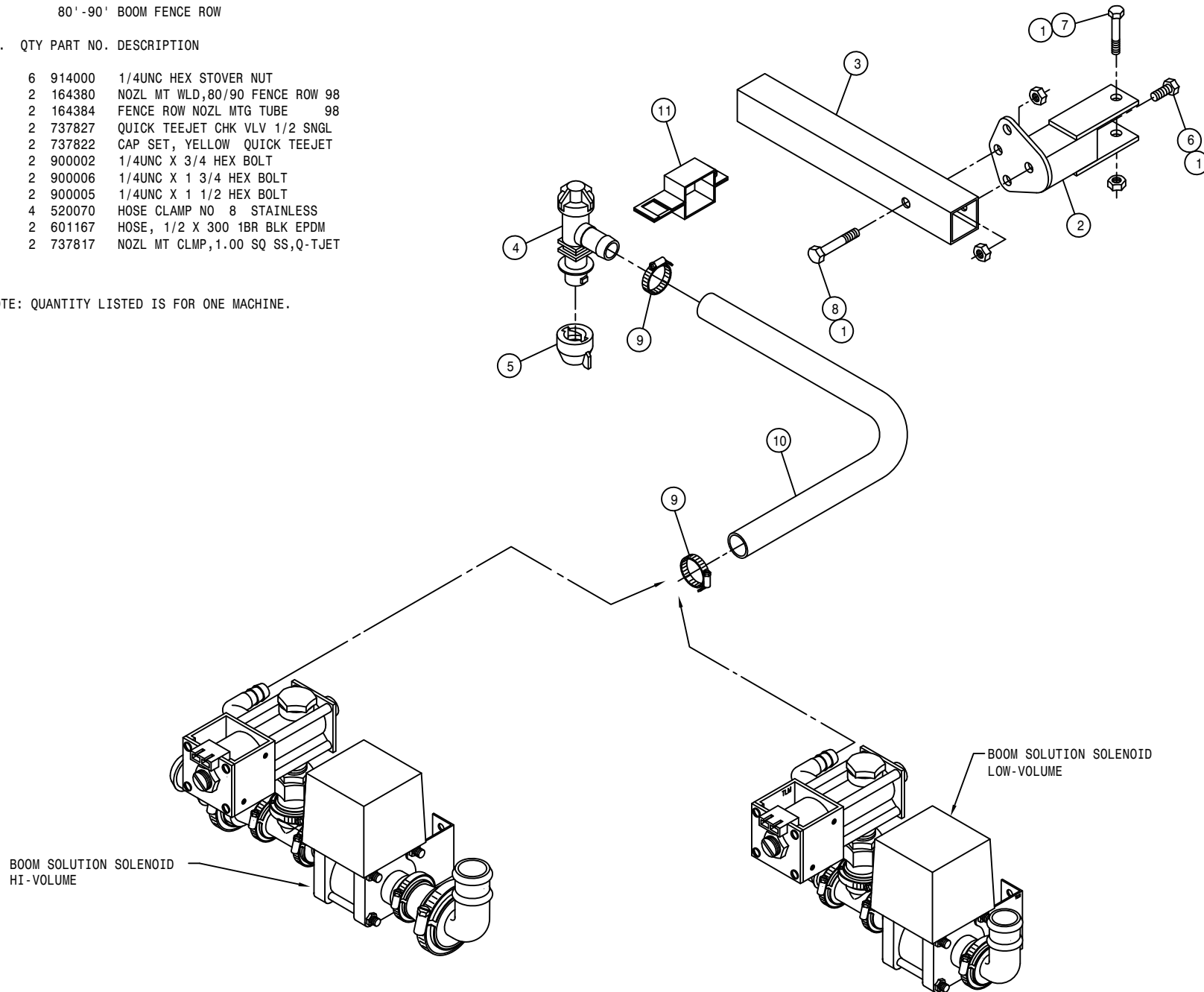

SOLUTION HOISING FOR 60' BOOM (STANDARD)

DET. QTY PART NO. DESCRIPTION

1	1	601451	HOSE, 2 X 69 2F-1W EPDM
2	1	601428	HOSE, 1 1/2 X 125 2F-1W EPDM
3	1	601429	HOSE, 1 1/2 X 143 2F-1W EPDM
4	2	601430	HOSE, 1 1/2 X 183 2F-1W EPDM
5	1	601456	HOSE, 3/4 X 117 1BR BLK EPDM
6	1	601457	HOSE, 3/4 X 130 1BR BLK EPDM
7	1	601425	HOSE, 1 X 192 2F-1W EPDM
8	1	601450	HOSE, 2 X 84 2F-1W EPDM
9	1	601423	HOSE, 2 X 12 2F-1W EPDM
10	2	690412	HOSE SPRING GUARD 2IN X 12 LG
11	1	601458	HOSE, 1 X 51 1BR BLK EDPM
12	1	601460	HOSE, 1 X 248 1BR BLK EDPM
13	1	601461	HOSE, 1 X 262 1BR BLK EDPM
14	2	342635	NYL HOSE SLEEVE,2.64ID X 60.00
15	3	342638	NYL HOSE SLEEVE,2.96ID X 65.00

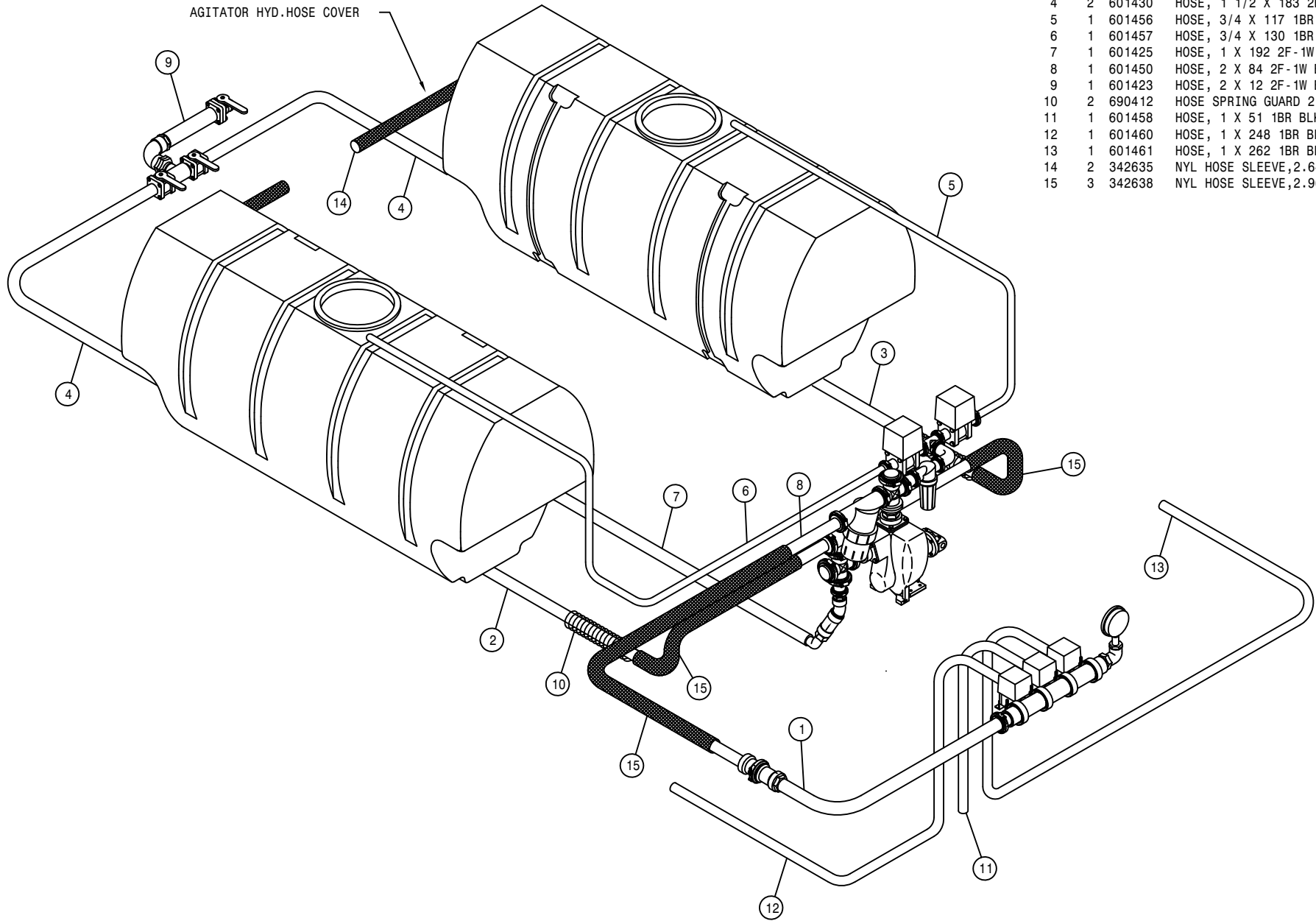

SOLUTION HOISING FOR 80'-90' BOOM (STANDARD)

DET. QTY PART NO. DESCRIPTION

1	1	601451	HOSE, 2 X 69 2F-1W EPDM
2	1	601428	HOSE, 1 1/2 X 125 2F-1W EPDM
3	1	601429	HOSE, 1 1/2 X 143 2F-1W EPDM
4	2	601430	HOSE, 1 1/2 X 183 2F-1W EPDM
5	1	601456	HOSE, 3/4 X 117 1BR BLK EPDM
6	1	601457	HOSE, 3/4 X 130 1BR BLK EPDM
7	1	601425	HOSE, 1 X 192 2F-1W EPDM
8	1	601450	HOSE, 2 X 84 2F-1W EPDM
9	1	601423	HOSE, 2 X 12 2F-1W EPDM
10	2	690412	HOSE SPRING GUARD 2IN X 12 LG
11	1	601458	HOSE, 1 X 51 1BR BLK EPDM
12	1	601460	HOSE, 1 X 248 1BR BLK EPDM
13	1	601461	HOSE, 1 X 262 1BR BLK EPDM
14	2	601390	HOSE, 1 X 160 1BR BLK EPDM
15	1	601459	HOSE, 1 X 245 1BR BLK EPDM
16	1	601462	HOSE, 1 X 294 1BR BLK EPDM
17	2	342635	NYL HOSE SLEEVE, 2.64ID X 60.00
18	3	342638	NYL HOSE SLEEVE, 2.96ID X 65.00

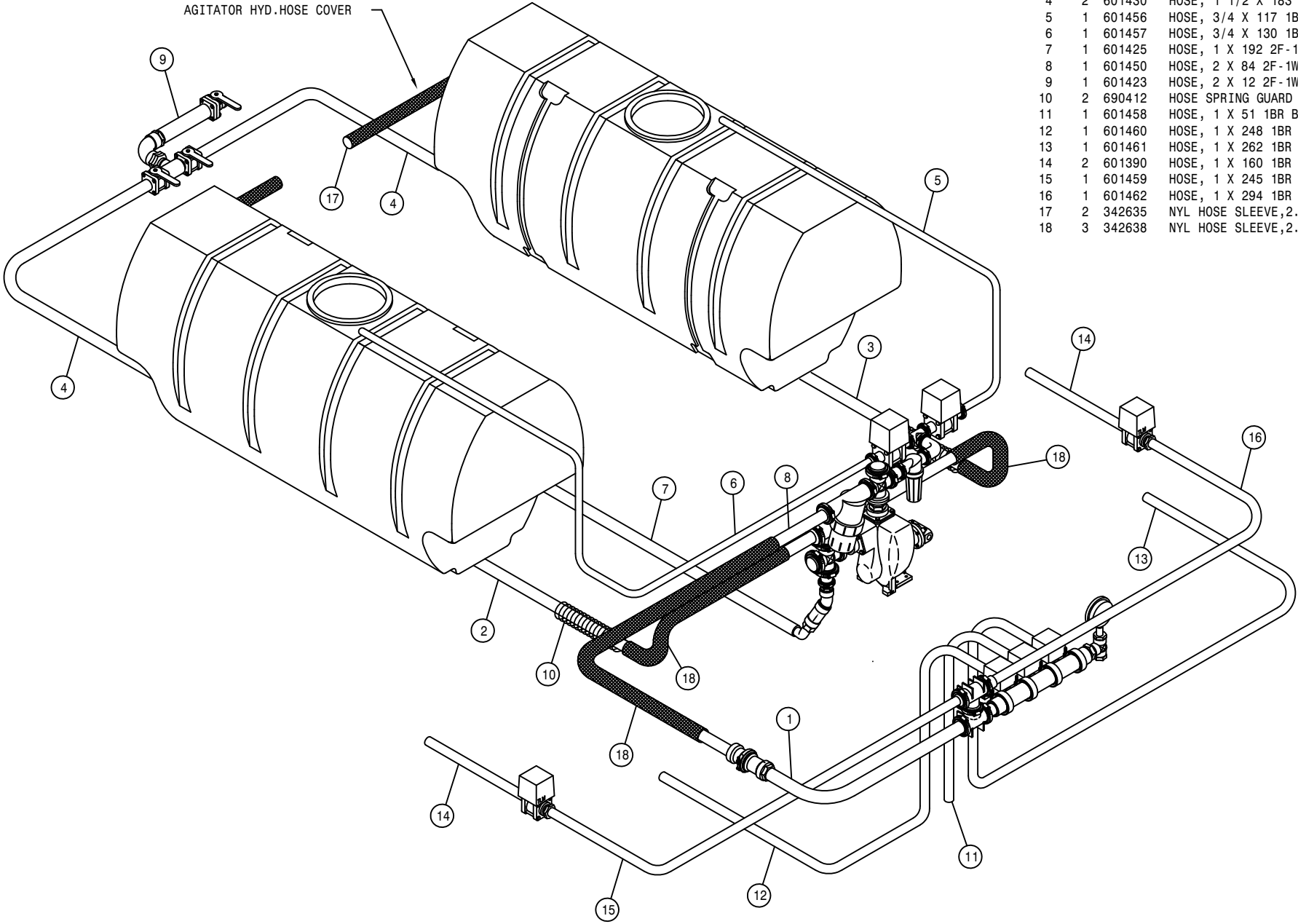

75

225075

SOLUTION HOISING FOR 60' BOOM (HI-VOLUME)

DET. QTY PART NO. DESCRIPTION

1	1	601451	HOSE, 2 X 69 2F-1W EPDM
2	1	601428	HOSE, 1 1/2 X 125 2F-1W EPDM
3	1	601429	HOSE, 1 1/2 X 143 2F-1W EPDM
4	2	601430	HOSE, 1 1/2 X 183 2F-1W EPDM
5	1	601456	HOSE, 3/4 X 117 1BR BLK EPDM
6	1	601457	HOSE, 3/4 X 130 1BR BLK EPDM
7	1	601425	HOSE, 1 X 192 2F-1W EPDM
8	1	601450	HOSE, 2 X 84 2F-1W EPDM
9	1	601423	HOSE, 2 X 12 2F-1W EPDM
10	2	690412	HOSE SPRING GUARD 2IN X 12 LG
11	1	601538	HOSE, 1 1/2 X 51 2BR BLK EPDM
12	1	601540	HOSE, 1 1/2 X 248 2BR BLK EPDM
13	1	601541	HOSE, 1 1/2 X 262 2BR BLK EPDM
14	2	342635	NYL HOSE SLEEVE, 2.64ID X 60.00
15	3	342638	NYL HOSE SLEEVE, 2.96ID X 65.00

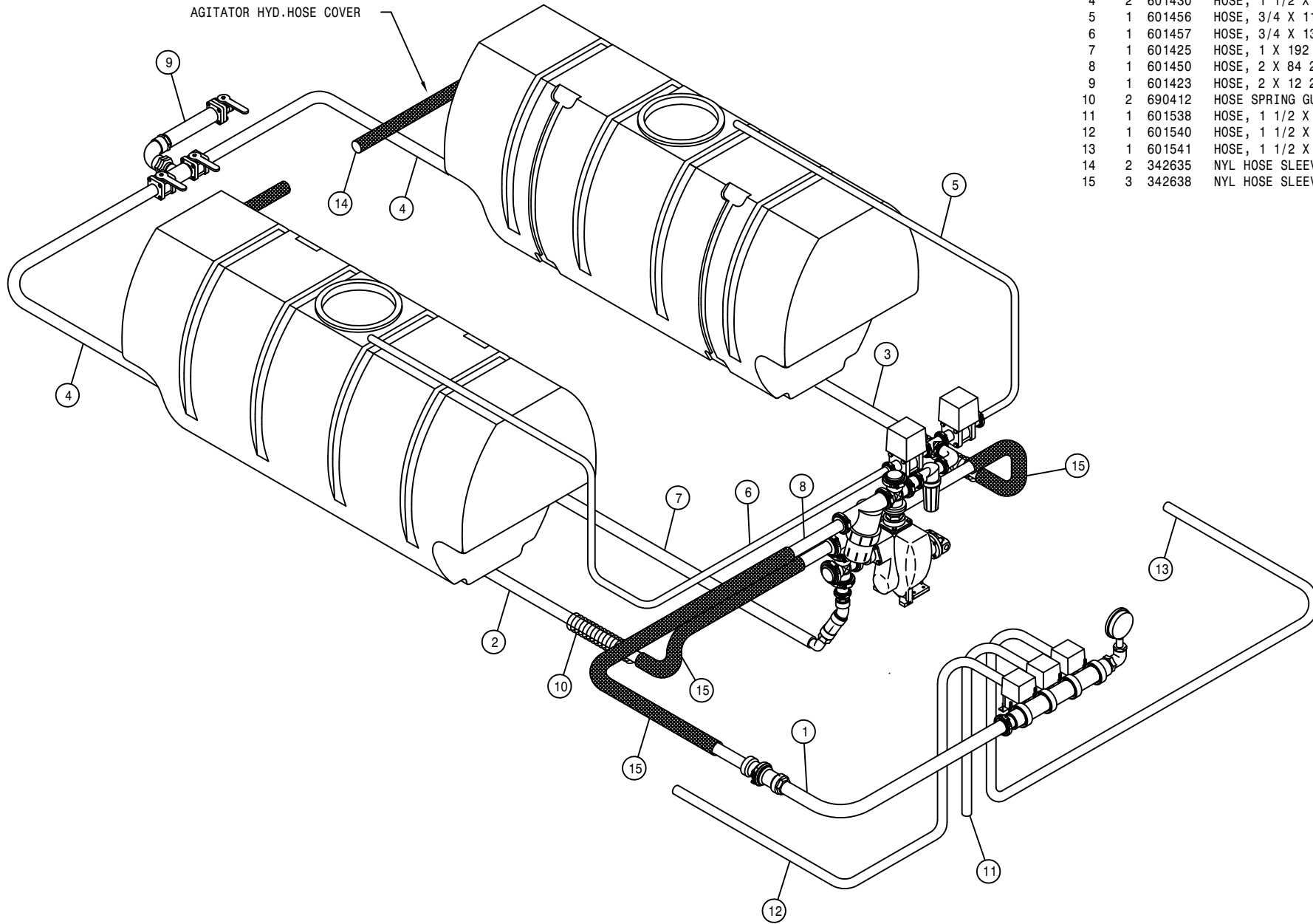

SOLUTION HOISING FOR 80'-90' BOOM (HI-VOLUME)

DET. QTY PART NO. DESCRIPTION

1	1	601451	HOSE, 2 X 69 2F-1W EPDM
2	1	601428	HOSE, 1 1/2 X 125 2F-1W EPDM
3	1	601429	HOSE, 1 1/2 X 143 2F-1W EPDM
4	2	601430	HOSE, 1 1/2 X 183 2F-1W EPDM
5	1	601456	HOSE, 3/4 X 117 1BR BLK EPDM
6	1	601457	HOSE, 3/4 X 130 1BR BLK EPDM
7	1	601425	HOSE, 1 X 192 2F-1W EPDM
8	1	601450	HOSE, 2 X 84 2F-1W EPDM
9	1	601423	HOSE, 2 X 12 2F-1W EPDM
10	2	690412	HOSE SPRING GUARD 2IN X 12 LG
11	2	601444	HOSE, 1 1/2 X 51 2F-1W EPDM
12	1	601540	HOSE, 1 1/2 X 248 2BR BLK EPDM
13	1	601541	HOSE, 1 1/2 X 262 2BR BLK EPDM
14	2	601445	HOSE, 1 1/2 X 160 2F-1W EPDM
15	1	601539	HOSE, 1 1/2 X 245 2BR BLK EPDM
16	1	601542	HOSE, 1 1/2 X 294 2BR BLK EPDM
17	2	342635	NYL HOSE SLEEVE, 2.64ID X 60.00
18	3	342638	NYL HOSE SLEEVE, 2.96ID X 65.00
19	2	601469	HOSE, 1 1/2 X 110 2F-1W EPDM
20	1	601538	HOSE, 1 1/2 X 51 2BR BLK EPDM

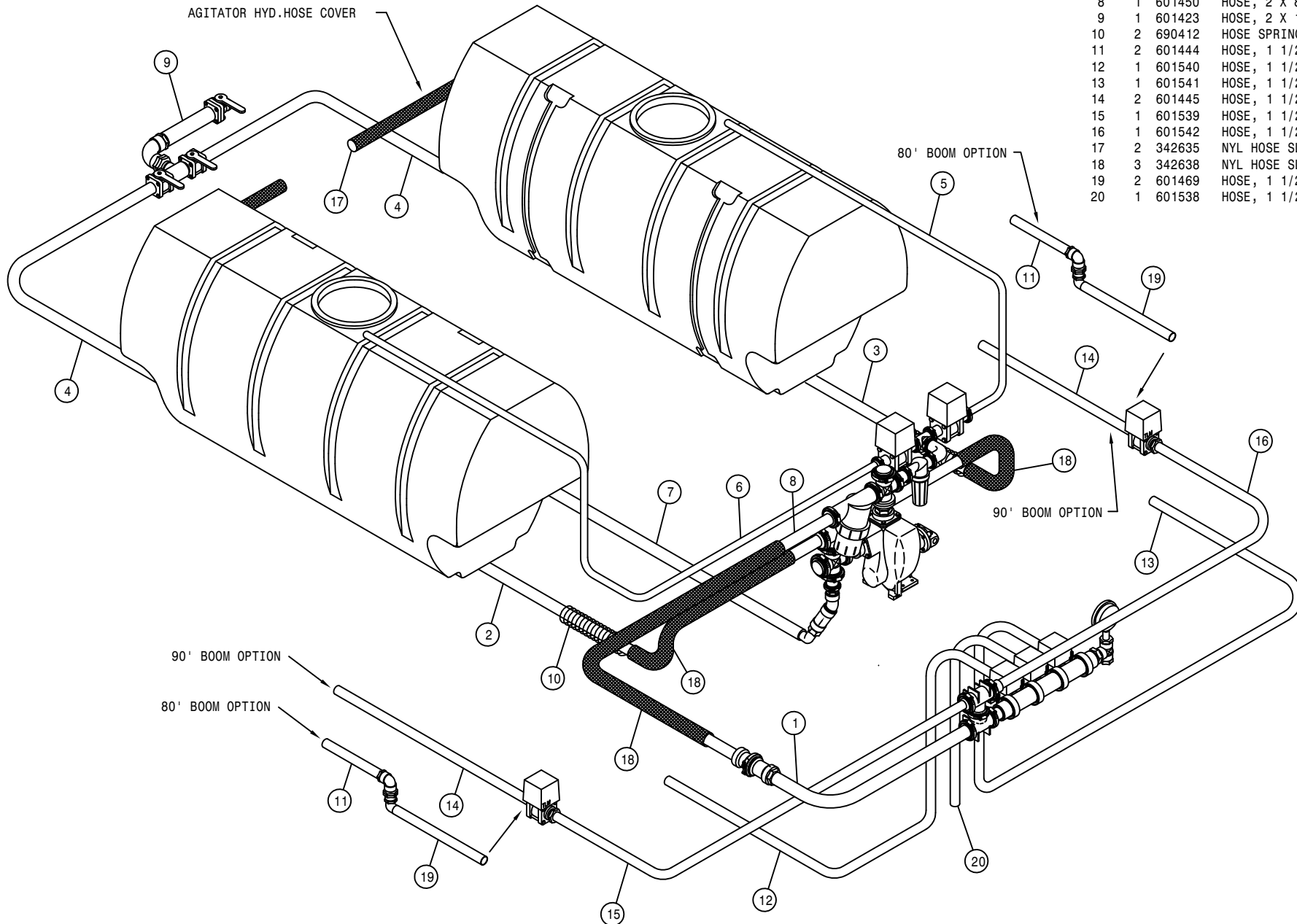

AGITATOR HYD. HOSE COVER

80' BOOM OPTION

90' BOOM OPTION

90' BOOM OPTION

80' BOOM OPTION

BOOM FEEDER TEE ASSEMBLY

DET. QTY PART NO. DESCRIPTION

DET.	QTY	PART NO.	DESCRIPTION
1	3	160986	CHAIN, 12.00 LONG
2	2	470237	1/4UNC-1 1/2ID-3 1/4 U-BOLT
3	4	473973	.31UNC-1.31ID-2.0 SQ U-BOLT SS
4	2	473974	.31UNC-2.56ID-3.5 U-BOLT SS
5	3	164423	FEEDER TEE MT, HIVOL
6	6	500022	3/4NPT-3/4HOSE BARB, POLY
7	1	500030	1 1/2"NPT PIPE TEE, POLY
8	2	500040	1 1/2 X 3/4 NPT BUSH, POLY
9	1	500093	1.50HOSEBARB-90-FEMALE COUPLER
10	1	500094	1.50MNPT-MALE COUPLER POLY
11	1	500095	CAP FOR 1.50 MALE COUPLER POLY
12	6	520055	HOSE CLAMP NO 12 STAINLESS
13	2	500026	3/4NPT-90-1"HOSE BARB, POLY
14	2	520090	HOSE CLAMP NO 16 STAINLESS
15	1	520133	1.81/2.06 T-BOLT HOSE CLAMP SS
16	2	505218	3/4 NPT PIPE TEE, POLY
17	2	696203	.75MNPT-FEMALE COUPLER POLY
18	2	696202	.75FNPT-MALE COUPLER POLY
19	2	696204	PLUG FOR .75 FEMALE COUPLER
20	8	914000	1/4UNC HEX STOVER NUT
21	12	914017	5/16UNC HEX NUT, TOP LOCK, SS
22	1	737817	NOZL MT CLMP, 1.00 SQ SS, Q-TJET
23	1	737822	CAP SET, YELLOW QUICK TEEJET
24	1	737829	QUICK TJET EL BODY DIAPH .75
25	1	737830	QUICK TJET TEE BODY DIAPH .75
26	1	737832	NOZL MT CLMP, 1.25 SQ, SS Q-TJET
27	2	473969	1/4UNC-1 1/2 X 2 3/4 RD U-BOLT
28	1	520067	HOSE CLAMP NO 28 STAINLESS

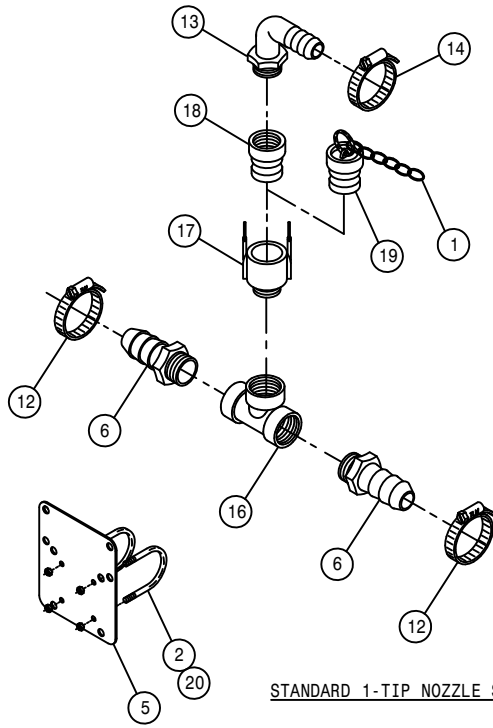

STANDARD 1-TIP NOZZLE SPACING

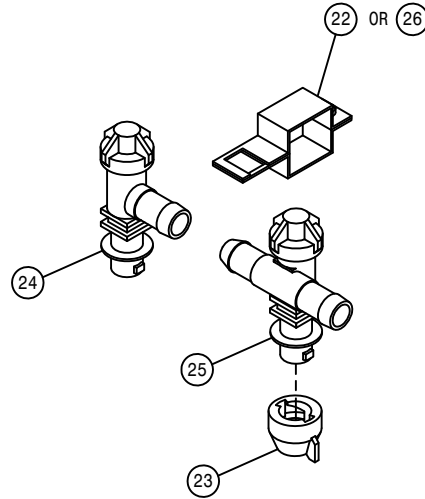

NOTE: DETAIL 15 IS USED WITH 1 1/2 I.D.  
2F-1W EPDM HOSE.

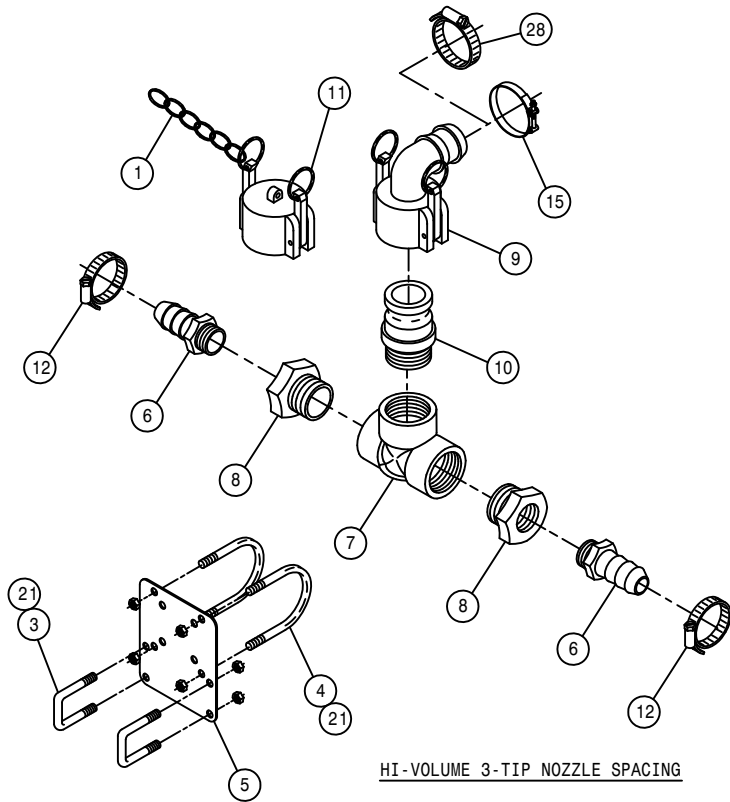

HI-VOLUME 3-TIP NOZZLE SPACING

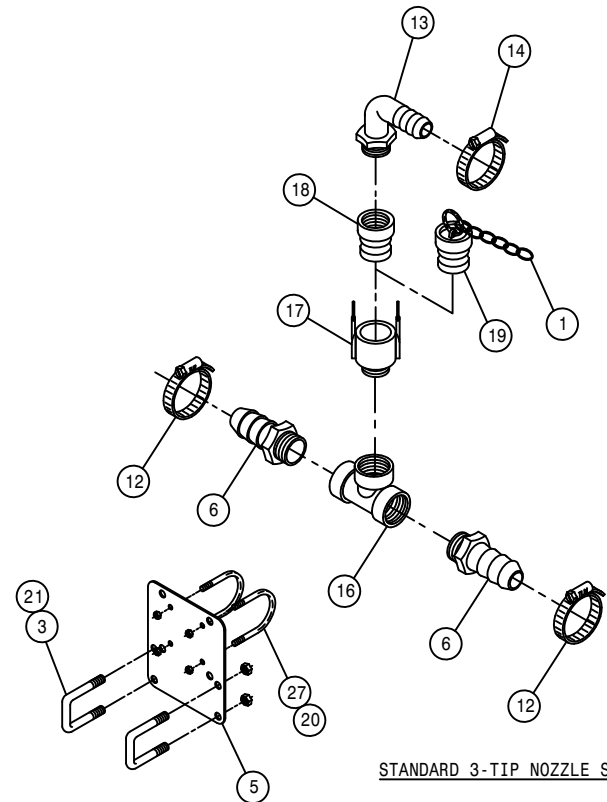

STANDARD 3-TIP NOZZLE SPACING

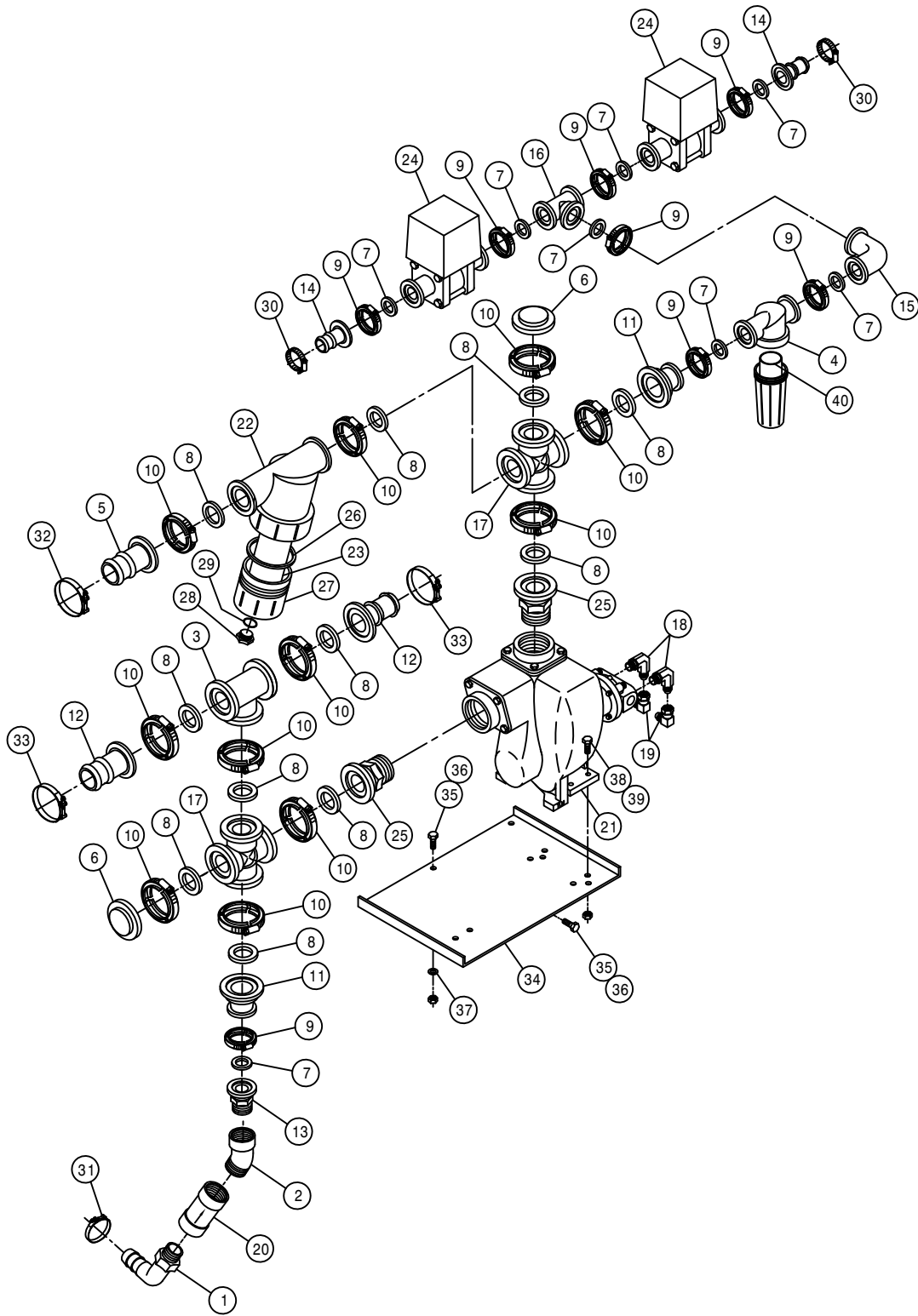

SOLUTION PUMP ASSEMBLY

DET.	QTY	PART NO.	DESCRIPTION
1	1	500024	1"NPT-90-1"HOSE BARB, POLY
2	1	500088	1"NPT-45 ST EL, POLY
3	1	500151	2" FLANGE TEE POLY
4	1	690660	LINE "T" STRAINER, 1" FLANGE
5	1	500154	2" FLANGE-2" HOSE BARB POLY
6	2	500156	2" FLANGE CAP PLUG POLY
7	8	500157	1" FLANGE GASKET EPDM
8	11	500158	1 1/2" GASKET FOR 2" FLANGE
9	8	500159	1" FLANGE CLAMP, S.S.
10	11	500160	2" FLANGE CLAMP, S.S.
11	2	500161	2"FLANGE-1"FLANGE COUPLER,POLY
12	2	500162	2" FLANGE-1 1/2 HOSE BARB POLY
13	1	500163	1" FLANGE-1" MNPT ADPTR POLY
14	2	500170	1" FLANGE-3/4" HOSE BARB POLY
15	1	500174	1" FLANGE-90-1" FLANGE LBO POLY
16	1	500175	1" FLANGE TEE POLY
17	2	500176	2" FLANGE CROSS POLY
18	2	618241	3/4MJIC-90-3/4MOR LBO
19	2	618609	3/4MJIC-90-3/4FJIC SWIV LBO
20	1	690488	1.00 CHECK VLV, SPRING LOADED
21	1	690552	FLOMAX 8, 2" PUMP
22	1	690628	LINE "Y" STRAINER, 2" FLANGE
23	1	690629	50 MESH SCREEN FOR 690628
24	2	696177	ELECT BALL VLV,1"FLANGE TJET
25	2	500182	2" FLANGE-2"MNPT ADPTR S.S.
26	1	690630	GASKET FOR 690628
27	1	690631	END CAP FOR 690628
28	1	690632	CLEAN-OUT PLUG FOR 690628
29	1	690633	O-RING,EDPM FOR 690628 PLUG
30	2	520055	HOSE CLAMP NO 12 STAINLESS
31	1	520138	1.38/1.56 T-BOLT HOSE CLAMP
32	1	520141	2.31/2.62 T-BOLT HOSE CLAMP
33	2	520133	1.81/2.06 T-BOLT HOSE CLAMP SS
34	1	690530	2" SOLU PUMP MT WLD 95
35	3	900129	3/8UNC X 1" HEX BOLT
36	3	914004	3/8UNC HEX STOVER NUT
37	2	920002	3/8 SAE FLAT WASHER
38	4	900066	5/16UNC X 1 1/4 HEX BOLT
39	4	914002	5/16UNC HEX STOVER NUT
40	1	690661	50 MESH SCREEN FOR 690660

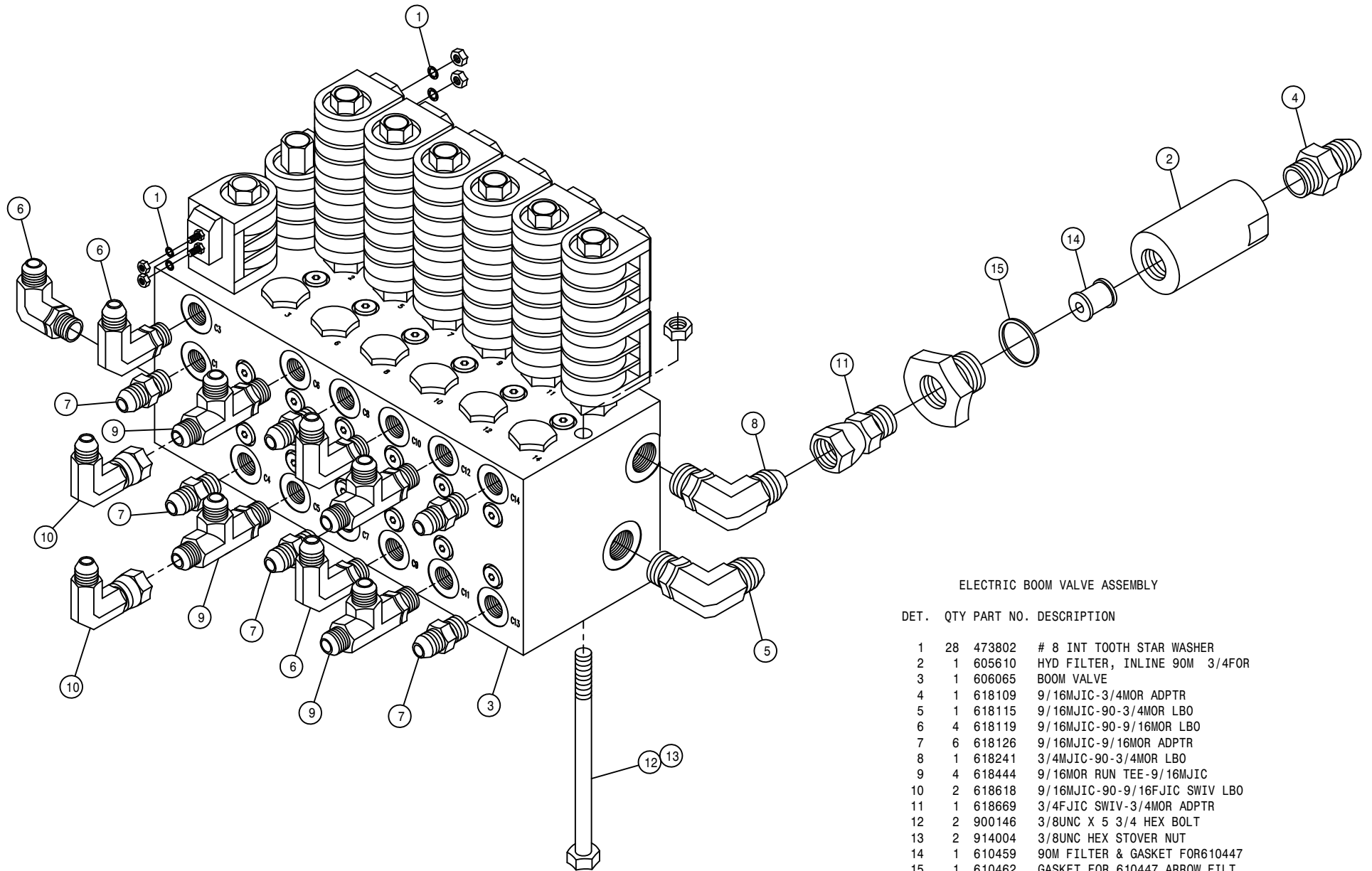

ELECTRIC BOOM VALVE ASSEMBLY

DET. QTY PART NO. DESCRIPTION

1	28	473802	# 8 INT TOOTH STAR WASHER
2	1	605610	HYD FILTER, INLINE 90M 3/4FOR
3	1	606065	BOOM VALVE
4	1	618109	9/16MJIC-3/4MOR ADPTR
5	1	618115	9/16MJIC-90-3/4MOR LBO
6	4	618119	9/16MJIC-90-9/16MOR LBO
7	6	618126	9/16MJIC-9/16MOR ADPTR
8	1	618241	3/4MJIC-90-3/4MOR LBO
9	4	618444	9/16MOR RUN TEE-9/16MJIC
10	2	618618	9/16MJIC-90-9/16FJIC SWIV LBO
11	1	618669	3/4FJIC SWIV-3/4MOR ADPTR
12	2	900146	3/8UNC X 5 3/4 HEX BOLT
13	2	914004	3/8UNC HEX STOVER NUT
14	1	610459	90M FILTER & GASKET FOR610447
15	1	610462	GASKET FOR 610447 ARROW FILT



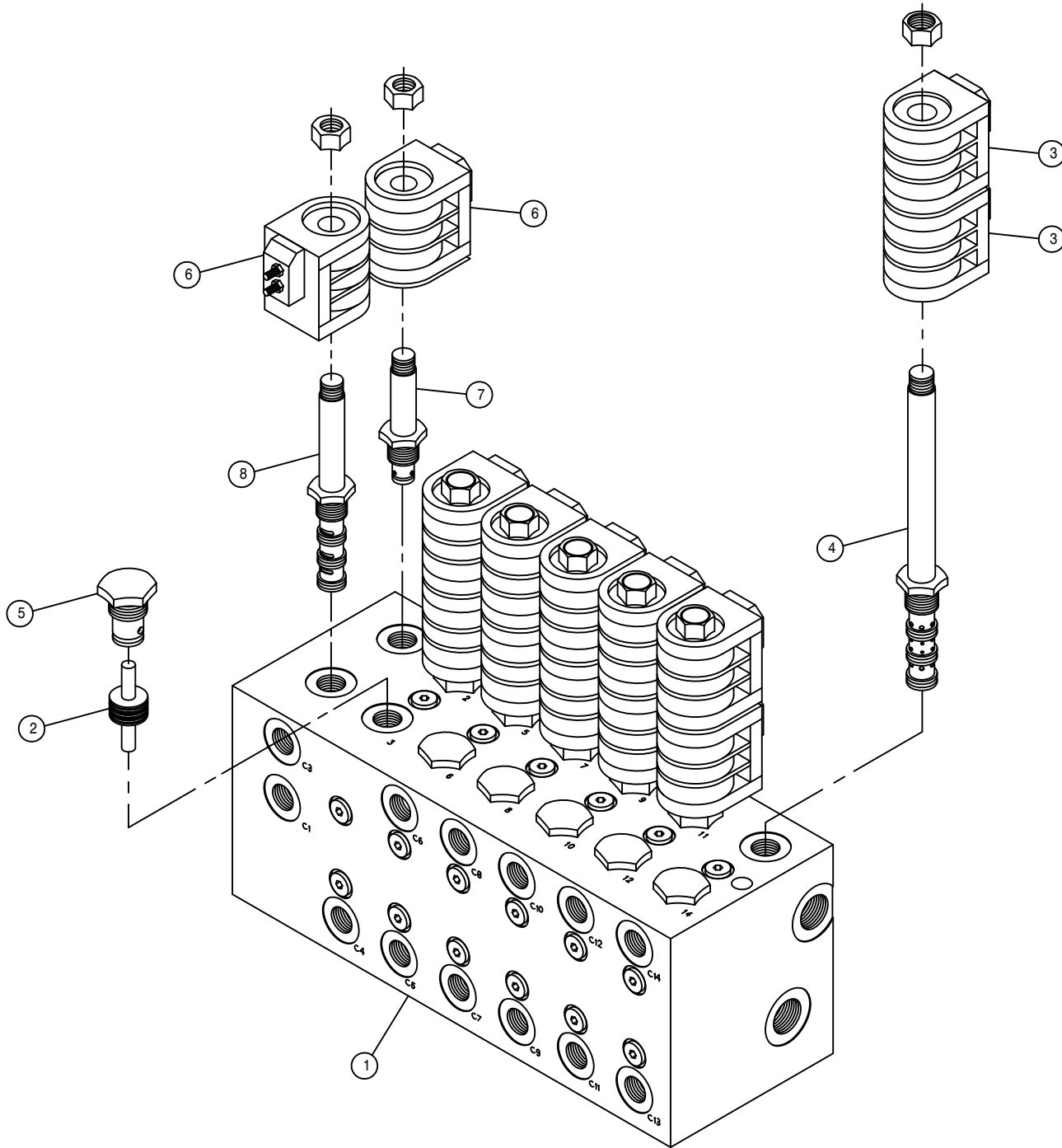

BOOM CONTROL HYD MANIFOLD ASSEMBLY

DET.	QTY	PART NO.	DESCRIPTION
1	1	606065	BOOM VALVE
2	6	606058	PISTON ASSY FOR 606050
3	12	606093	COIL (63900202) -606050/067/090
4	6	606057	SOLE VLV(DGS4M00)FOR 606050/51
5	12	606059	CHECK VALVE FOR 606050
6	2	606091	COIL (39660030) FOR 606065/066
7	1	606061	SOLE VLV(DES2C00) FOR 606051
8	1	606062	SOLE VLV(DGS4B00) FOR 606051

LIFTARM ASSEMBLY

DET.	QTY	PART NO.	DESCRIPTION
1	2	160471	LWR LIFT ARM WLD 8540-8250 87
2	1	164350	RH LIFT ARM EXT WLD, 2100 98
3	1	164351	LH LIFT ARM EXT WLD, 2100 98
4	12	160691	BUSH LIFT ARM LONG 470
5	12	470287	TUBE CLAMP, .375-.375 (PAIR)
6	1	164651	UPPER LIFT ARM WLD,284 2001
7	12	471005	1/4 28 X 1/2 GREASE ZERK
8	1	164364	RH LIFTARM V-PLT MT WLD2100 98
9	1	164365	LH LIFTARM V-PLT MT WLD2100 98
10	2	293404	FRT TURN/WARN LITE ASSY2100 98
11	1	615761	LIFT RAISE HYD TUBE ASSY
12	1	615762	LIFT LOWER HYD TUBE ASSY
13	1	615764	LEVEL LOWER HYD TUBE ASSY
14	1	615763	LEVEL RAISE HYD TUBE ASSY
15	1	615767	BOOM EXTN LOWER HYD TUBE ASSY
16	1	615766	BOOM EXTN RAISE HYD TUBE ASSY
17	1	615769	RH FOLD LOWER HYD TUBE ASSY
18	1	615768	RH FOLD RAISE HYD TUBE ASSY
19	3	914000	1/4UNC HEX STOVER NUT
20	2	621011	TRANSOM LIFT CYL ASSY
21	2	473779	10MM-1.50 HEX NUT
22	3	900013	1/4UNC X 3 3/4 HEX BOLT
23	8	619010	9/16MJIC UNION
24	4	900342	5/8UNC X 4" HEX BOLT
25	8	900343	5/8UNC X 4 1/2 HEX BOLT
26	8	900334	5/8UNC X 1 3/4 HEX BOLT
27	8	900338	5/8UNC X 3" HEX BOLT
28	28	914010	5/8UNC HEX STOVER NUT
29	2	293402	HEADLIGHT ASSY, 2100 98
30	2	470100	3/8 INT TOOTH LOCK WASHER
31	1	291669	YELLOW LENS FOR 291668

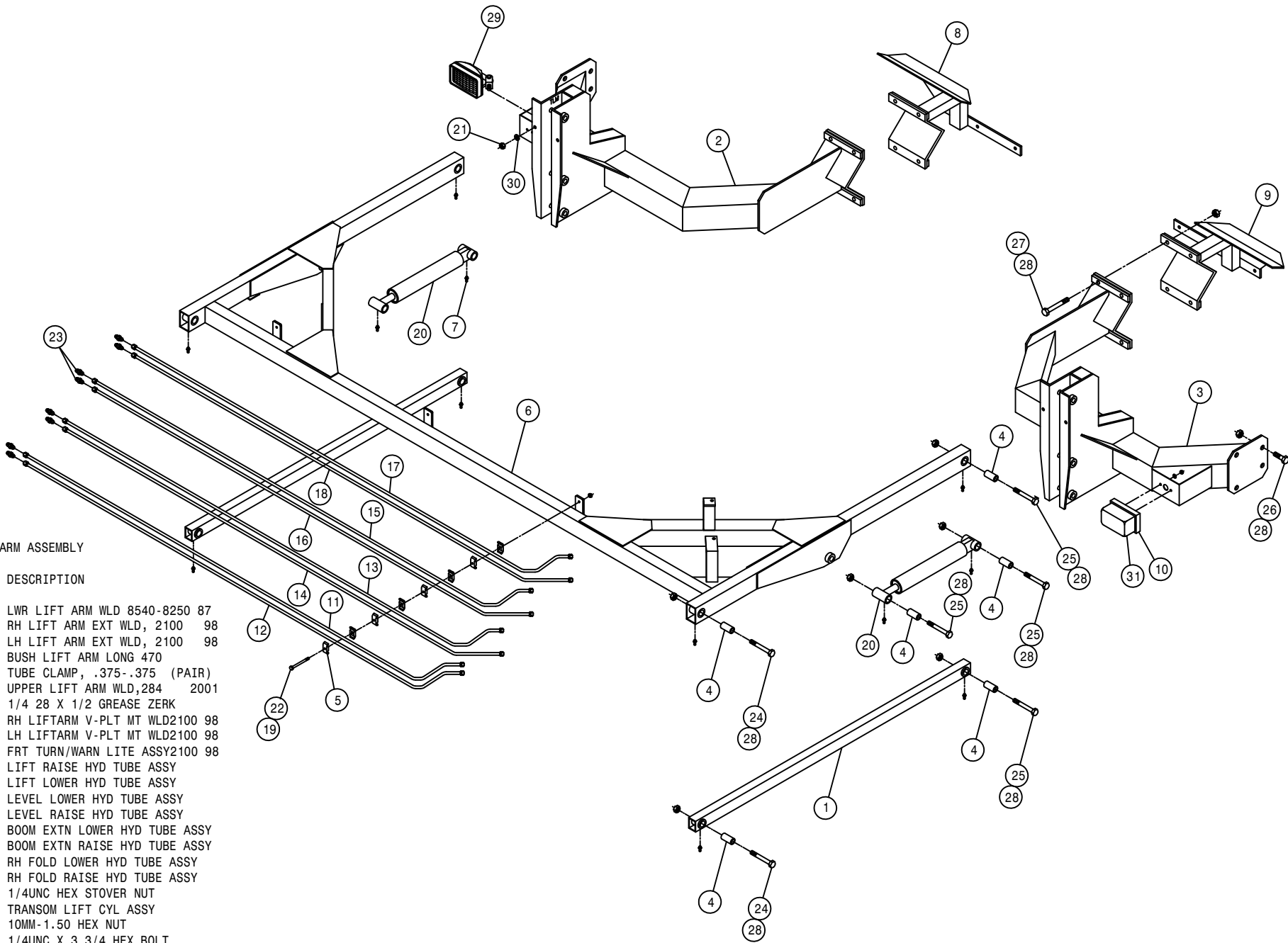

TRANSOM ASSEMBLY

DET. QTY PART NO. DESCRIPTION

DET.	QTY	PART NO.	DESCRIPTION
1	2	160429	FEEDER HOSE SUPPORT SPRING MT
2	4	160691	BUSH LIFT ARM LONG 470
3	2	164123	NOZL MT TUBE, 254/284 96
4	2	164125	NOZL MT TUBE HANGER CHAN 96
5	2	164127	NOZL MT TUBE CLAMP 96
6	2	164128	LEVEL CYL PIVOT BRKT WLD 96
7	2	164315	BOOM BREAKAWAY WLD 97
8	2	900848	5/8UNC X 4 3/4 HEX BOLT GR8
9	2	470136	3/8UNC-3 1/16ID-3 SQ U-BOLT
10	4	164264	5/8UNC X 3" EYE BOLT
11	6	471005	1/4 28 X 1/2 GREASE ZERK
12	8	900007	1/4UNC X 2" HEX BOLT
13	2	900849	5/8UNC X 4 1/2 HHCS,7/8THD GR8
14	2	910010	5/8UNC HEX NUT
15	8	914000	1/4UNC HEX STOVER NUT
16	4	914004	3/8UNC HEX STOVER NUT
17	1	164308	TRANSOM WLD, 284 97
18	12	914010	5/8UNC HEX STOVER NUT
19	8	920005	5/8 SAE FLAT WASHER
20	4	920006	3/4 SAE FLAT WASHER
21	2	164230	BOOM PIVOT PIN, .75 X 13.31 96
22	4	470162	COTTER PIN 3/16 X 1 1/2 SQCUT
23	2	482000	SPRING, .930D X 8.5LG, .072WIRE
24	2	520126	CUSH HOSE CLAMP 2IN X 5/8W
25	2	621015	BOOM LEVEL CYL ASSY
26	2	621013	BOOM HINGE FOLD CYL ASSY, 284
27	4	900829	5/8UNC X 4" HEX BOLT GR8
28	2	900844	5/8UNC X 2 3/4 HEX BOLT GR8
29	2	471023	GREASE ZERK 1/4-28 X 45
30	4	520099	HOSE CLAMP NO 40 STAINLESS
31	2	621016	ACCUMULATOR CYL ASSY, 60 BOOM
32	2	621017	ACCUMULATOR CYL ASSY, 80/90BOOM
33	4	629735	CAPLUG, 1 1/4" SQ, BLACK POLY

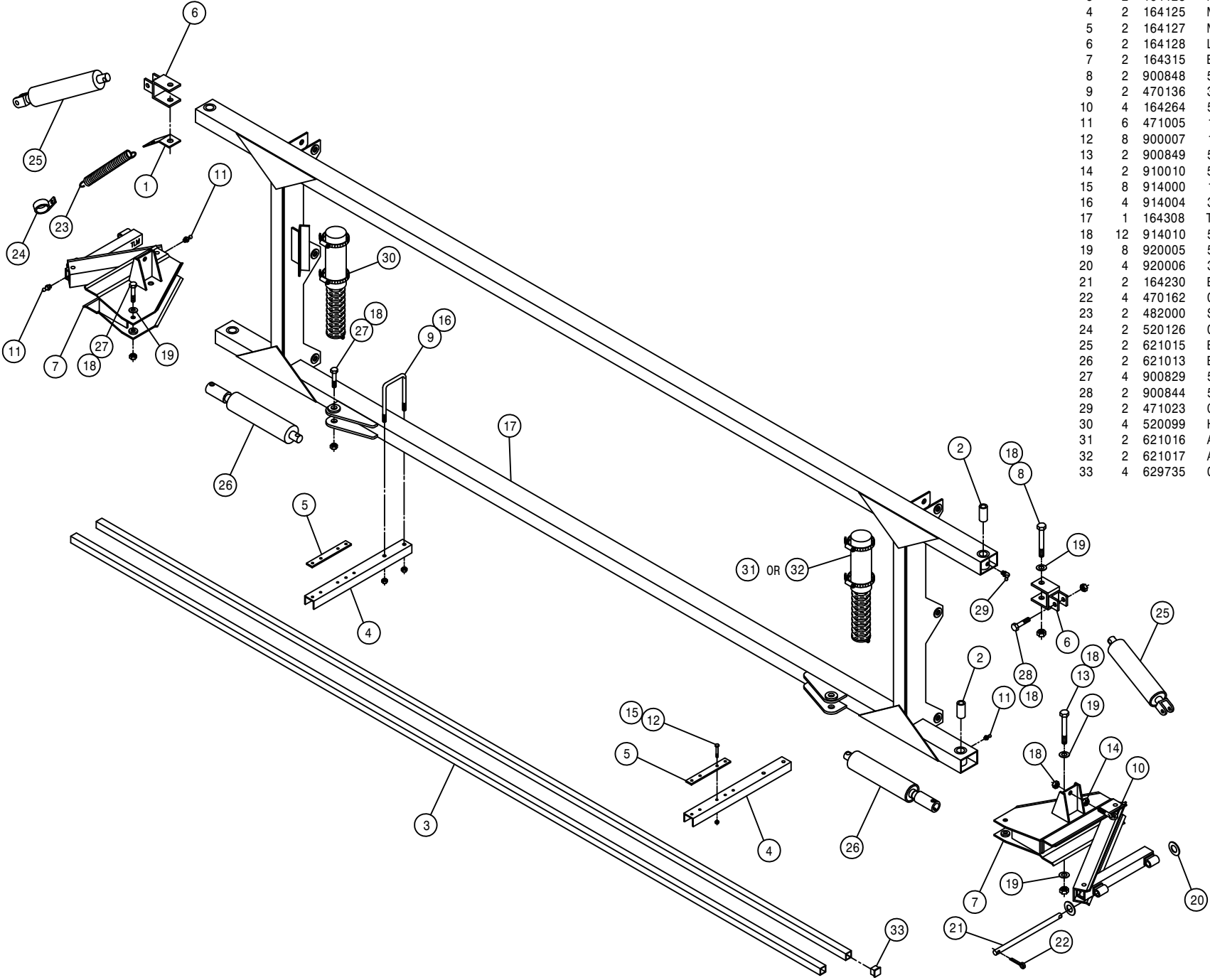

83

225083

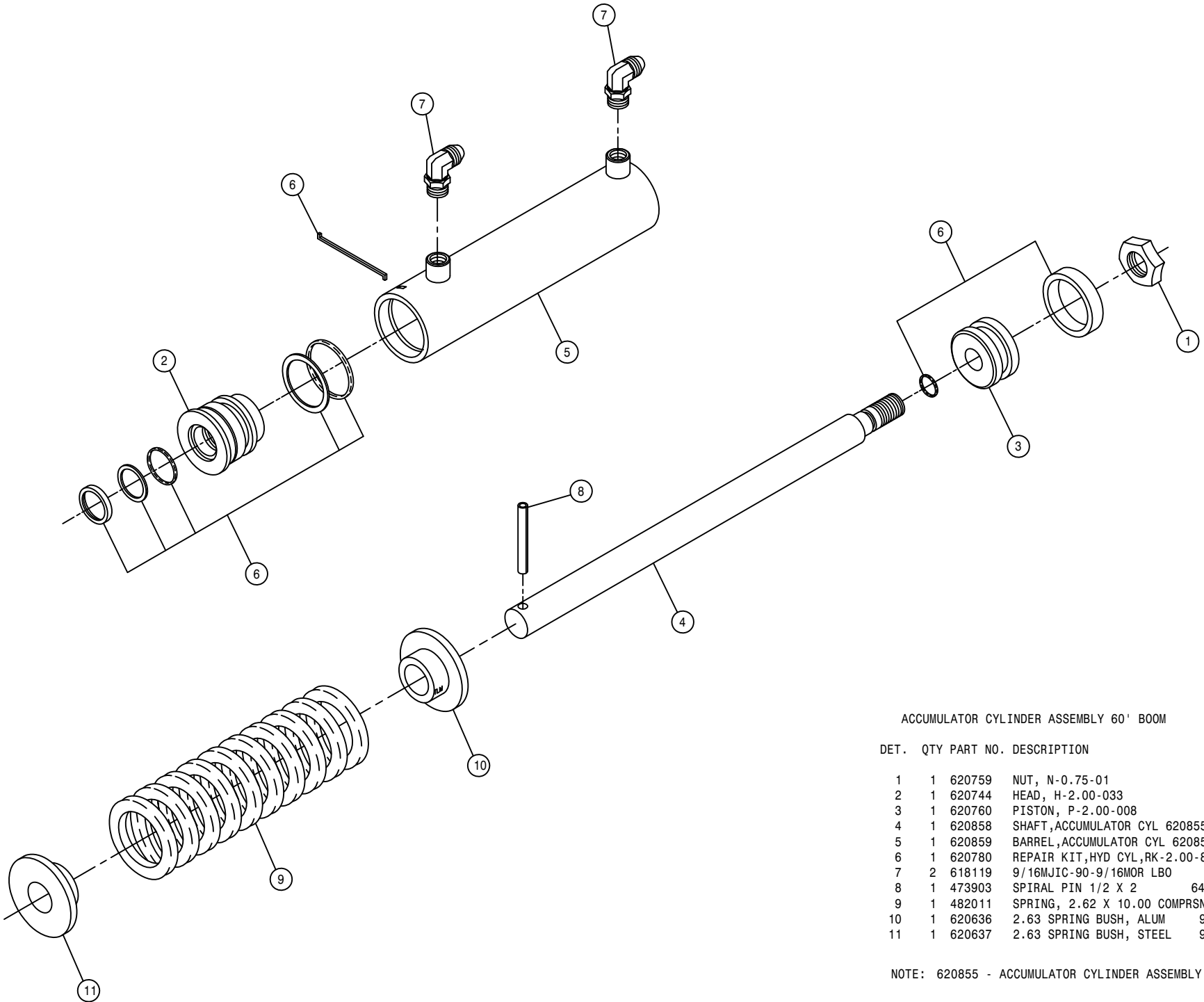

ACCUMULATOR CYLINDER ASSEMBLY 60' BOOM

DET.	QTY	PART NO.	DESCRIPTION
1	1	620759	NUT, N-0.75-01
2	1	620744	HEAD, H-2.00-033
3	1	620760	PISTON, P-2.00-008
4	1	620858	SHAFT, ACCUMULATOR CYL 620855
5	1	620859	BARREL, ACCUMULATOR CYL 620855
6	1	620780	REPAIR KIT, HYD CYL, RK-2.00-806
7	2	618119	9/16MJIC-90-9/16MOR LBO
8	1	473903	SPIRAL PIN 1/2 X 2 640
9	1	482011	SPRING, 2.62 X 10.00 COMPRSN
10	1	620636	2.63 SPRING BUSH, ALUM 96
11	1	620637	2.63 SPRING BUSH, STEEL 96

NOTE: 620855 - ACCUMULATOR CYLINDER ASSEMBLY 1-6

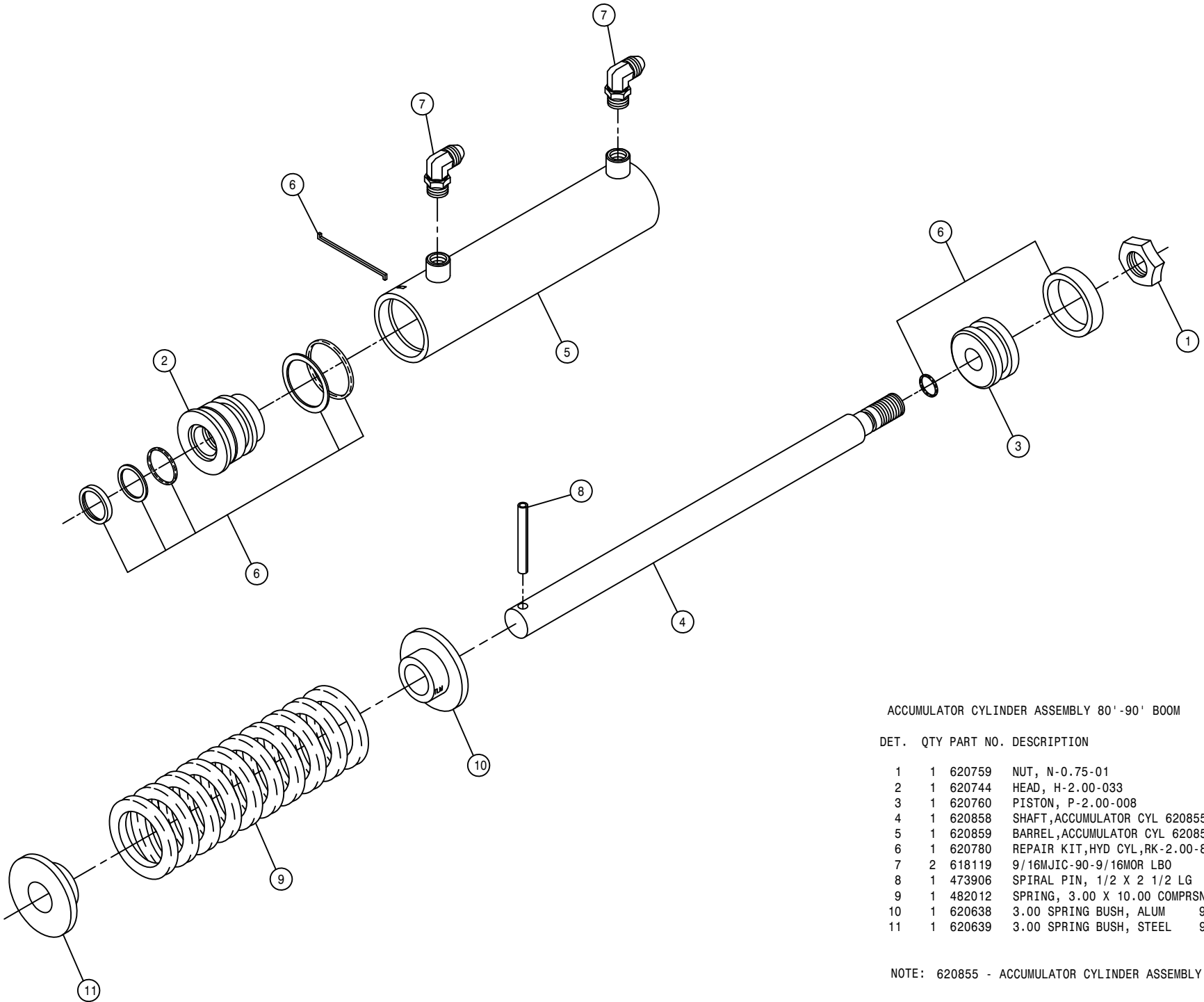

ACCUMULATOR CYLINDER ASSEMBLY 80'-90' BOOM

DET.	QTY	PART NO.	DESCRIPTION
	1	620759	NUT, N-0.75-01
	1	620744	HEAD, H-2.00-033
	1	620760	PISTON, P-2.00-008
	1	620858	SHAFT, ACCUMULATOR CYL 620855
	1	620859	BARREL, ACCUMULATOR CYL 620855
	1	620780	REPAIR KIT, HYD CYL, RK-2.00-806
	2	618119	9/16MJIC-90-9/16MOR LBO
	1	473906	SPIRAL PIN, 1/2 X 2 1/2 LG
	1	482012	SPRING, 3.00 X 10.00 COMPRSN
	1	620638	3.00 SPRING BUSH, ALUM 96
	1	620639	3.00 SPRING BUSH, STEEL 96

NOTE: 620855 - ACCUMULATOR CYLINDER ASSEMBLY 1-6

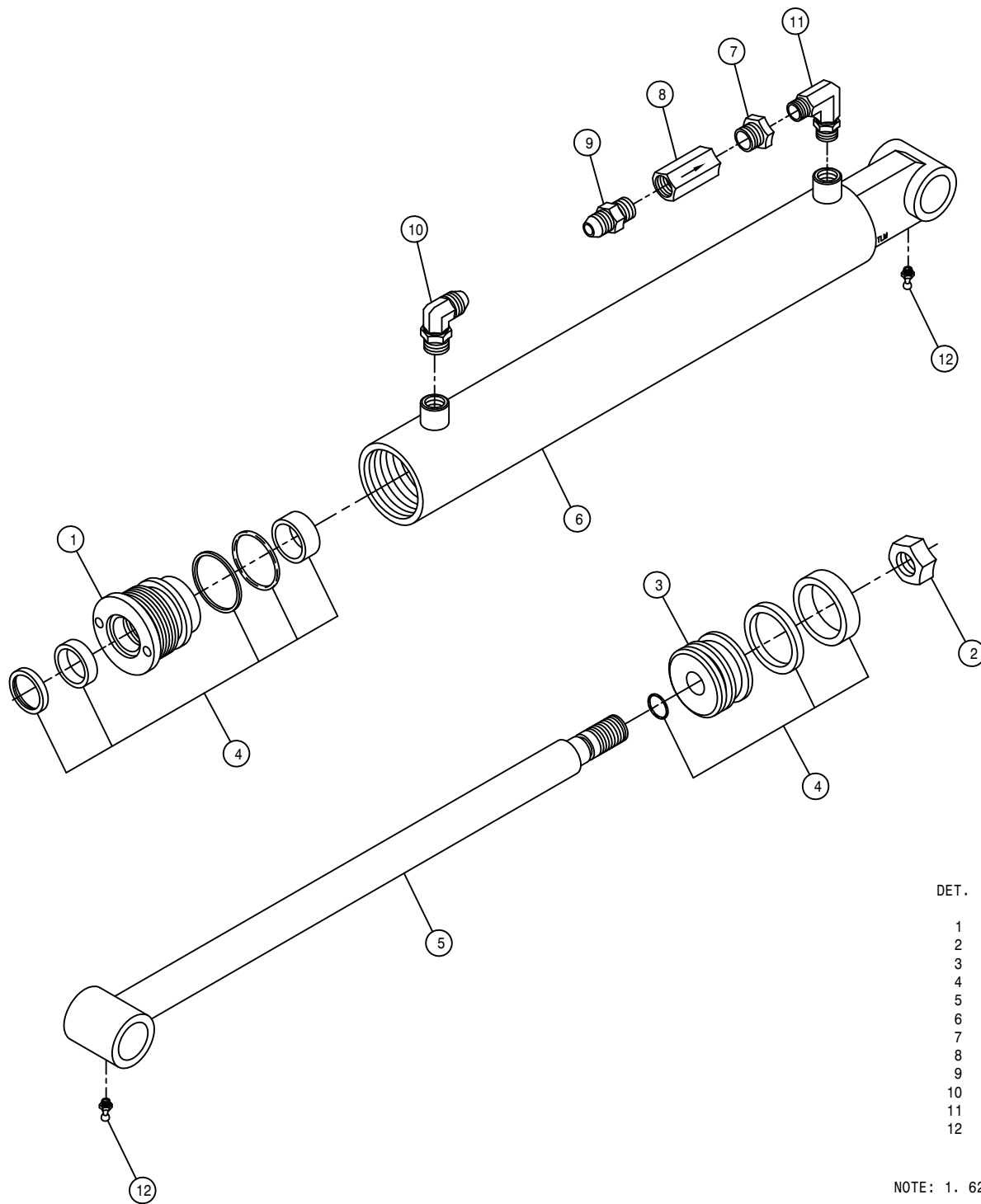

TRANSOM LIFT CYLINDER ASSEMBLY

DET.	QTY	PART NO.	DESCRIPTION
1	1	620748	HEAD, H-2.50-350
2	1	620759	NUT, N-0.75-01
3	1	620764	PISTON, P-2.50-107
4	1	620785	REPAIR KIT, HYD CYL, RK-2.50-800
5	1	620843	SHAFT, TRANSOM LIFT CYL 620840
6	1	620844	BARREL, TRANSOM LIFT CYL 620840
7	1	503010	RED BUSH 1/2MNPT-3/8FNPT, STEEL
8	1	610675	RESTRICTOR, .042 1-WAY, 1/2FNPT
9	1	618018	9/16MJIC-1/2MNPT ADPTR
10	1	618119	9/16MJIC-90-9/16MOR LBO
11	1	618651	9/16MOR-90-3/8MNPT LBO
12	2	471005	1/4 28 X 1/2 GREASE ZERK

NOTE: 1. 620840 - TRANSOM LIFT CYLINDER ASSEMBLY 1-6  
 2. 621011 - TRANSOM LIFT CYLINDER ASSEMBLY WITH FITTINGS

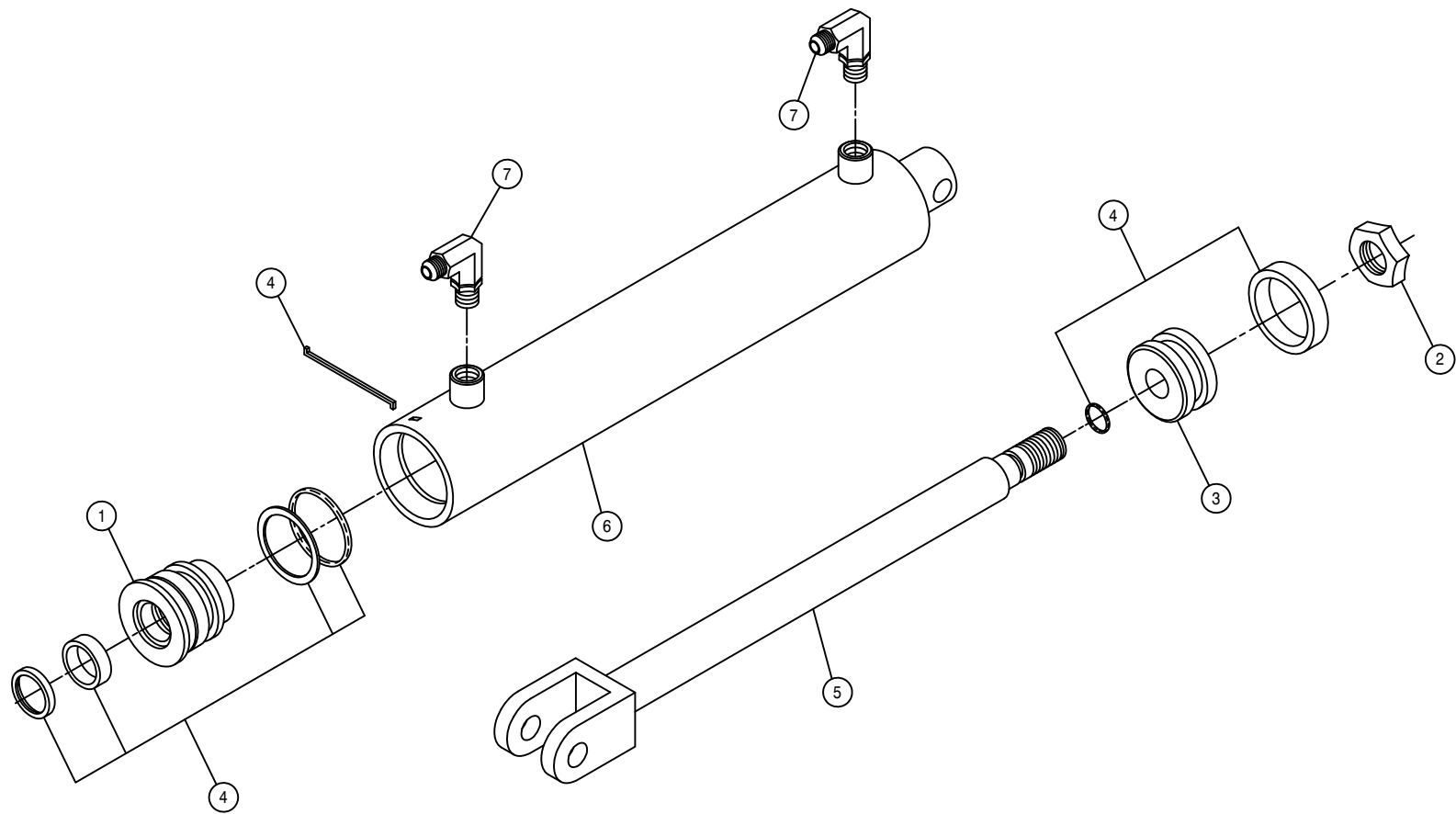

BOOM LEVEL CYLINDER ASSEMBLY

DET. QTY PART NO. DESCRIPTION

1	1	620744	HEAD, H-2.00-033
2	1	620759	NUT, N-0.75-01
3	1	620760	PISTON, P-2.00-008
4	1	620780	REPAIR KIT, HYD CYL, RK-2.00-806
5	1	620853	SHAFT, BOOM LEVEL CYL 620850
6	1	620854	BARREL, BOOM LEVEL CYL 620850
7	2	618119	9/16MJIC-90-9/16MOR LBO

NOTE: 1. 620850 - BOOM LEVEL CYLINDER ASSEMBLY 1-6  
 2. 621015 - BOOM LEVEL CYLINDER ASSEMBLY WITH FITTINGS

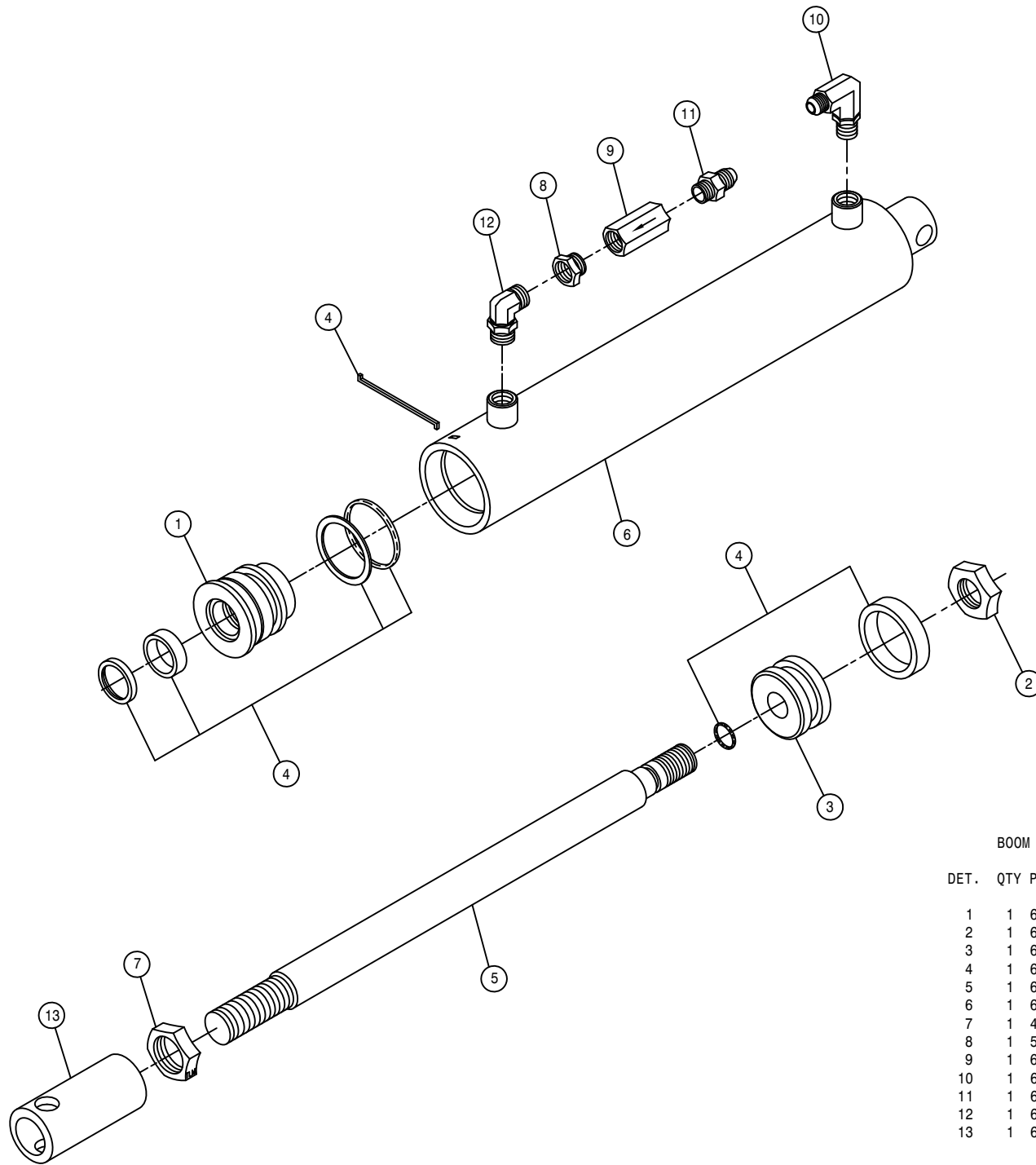

BOOM HINGE FOLD CYLINDER ASSEMBLY

DET.	QTY	PART NO.	DESCRIPTION
1	1	620744	HEAD, H-2.00-033
2	1	620759	NUT, N-0.75-01
3	1	620760	PISTON, P-2.00-008
4	1	620780	REPAIR KIT, HYD CYL, RK-2.00-806
5	1	620848	SHAFT, BOOM FOLD CYL 620845
6	1	620849	BARREL, BOOM FOLD CYL 620845
7	1	472322	7/8UNF HEX JAM NUT
8	1	503010	RED BUSH 1/2MNPT-3/8FNPT, STEEL
9	1	610450	RESTRICTOR .025 1-WAY, 1/2FNPT
10	1	614750	.042 ELBOW ASSY, 9/16MOR 90D
11	1	618018	9/16MJIC-1/2MNPT ADPTR
12	1	618651	9/16MOR-90-3/8MNPT LBO
13	1	620653	FOLD CYL ADJ SLEEVE

97

NOTE: 1. 620845 - BOOM HINGE FOLD CYLINDER ASSEMBLY 1-6  
 2. 621013 - BOOM HINGE FOLD CYLINDER ASSEMBLY WITH FITTINGS



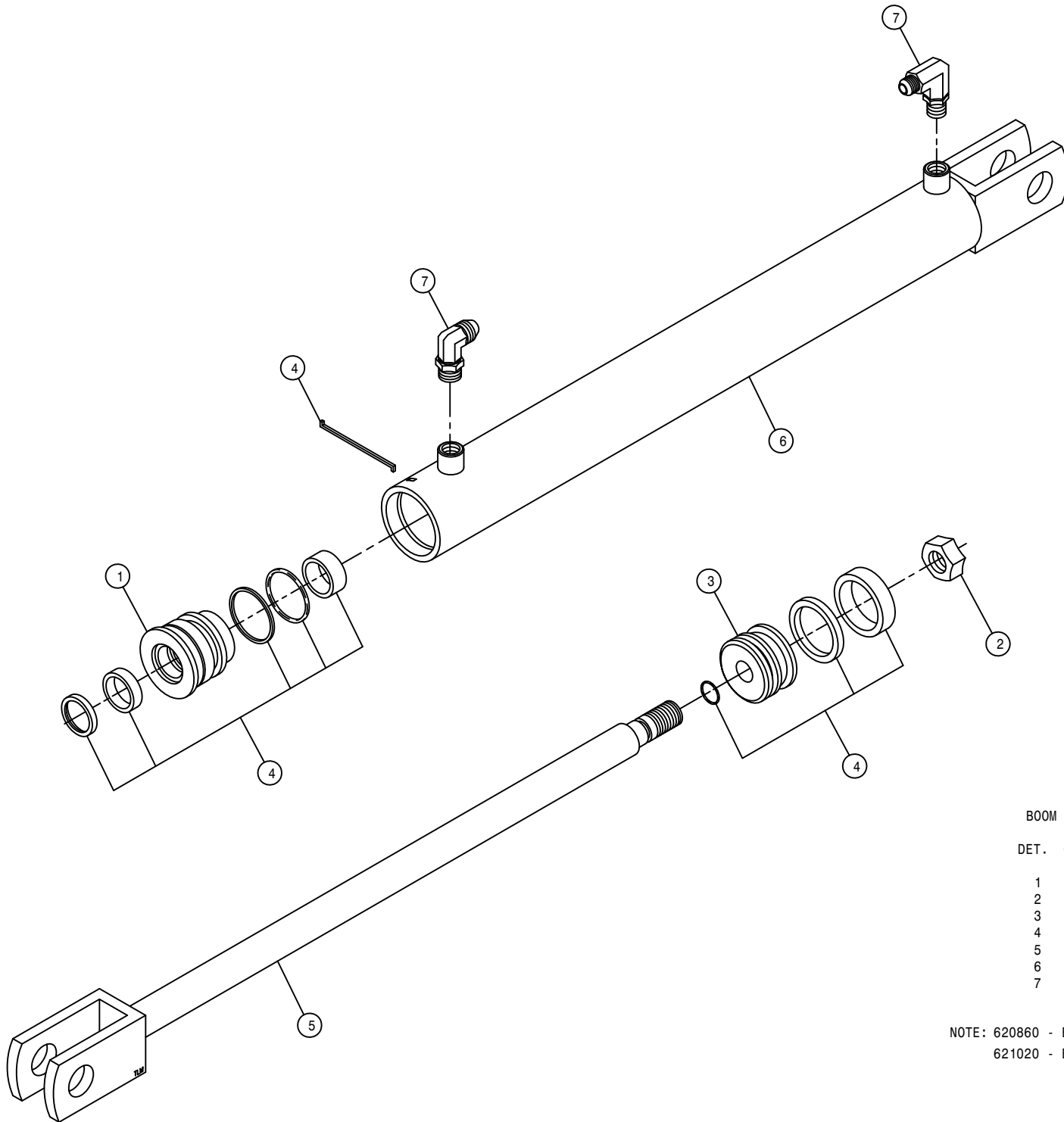

BOOM CENTER SECTION FOLD CYLINDER ASSEMBLY

DET. QTY PART NO. DESCRIPTION

1	1	620747	HEAD, H-2.50-075
2	1	620759	NUT, N-0.75-01
3	1	620761	PISTON, P-2.00-101
4	1	620784	REPAIR KIT, HYD CYL, RK-2.50-801
5	1	620863	SHAFT, BOOM SECT FOLD CYL 620860
6	1	620864	BARREL, BOOM FOLD CYL 620860
7	2	614750	.042 ELBOW ASSY, 9/16MOR 90D

NOTE: 620860 - BOOM CNTR SECT FOLD CYLINDER INCLUDES ITEMS 1-6.  
621020 - BOOM CNTR SECT FOLD CYLINDER ASSEMBLY WITH FITTINGS

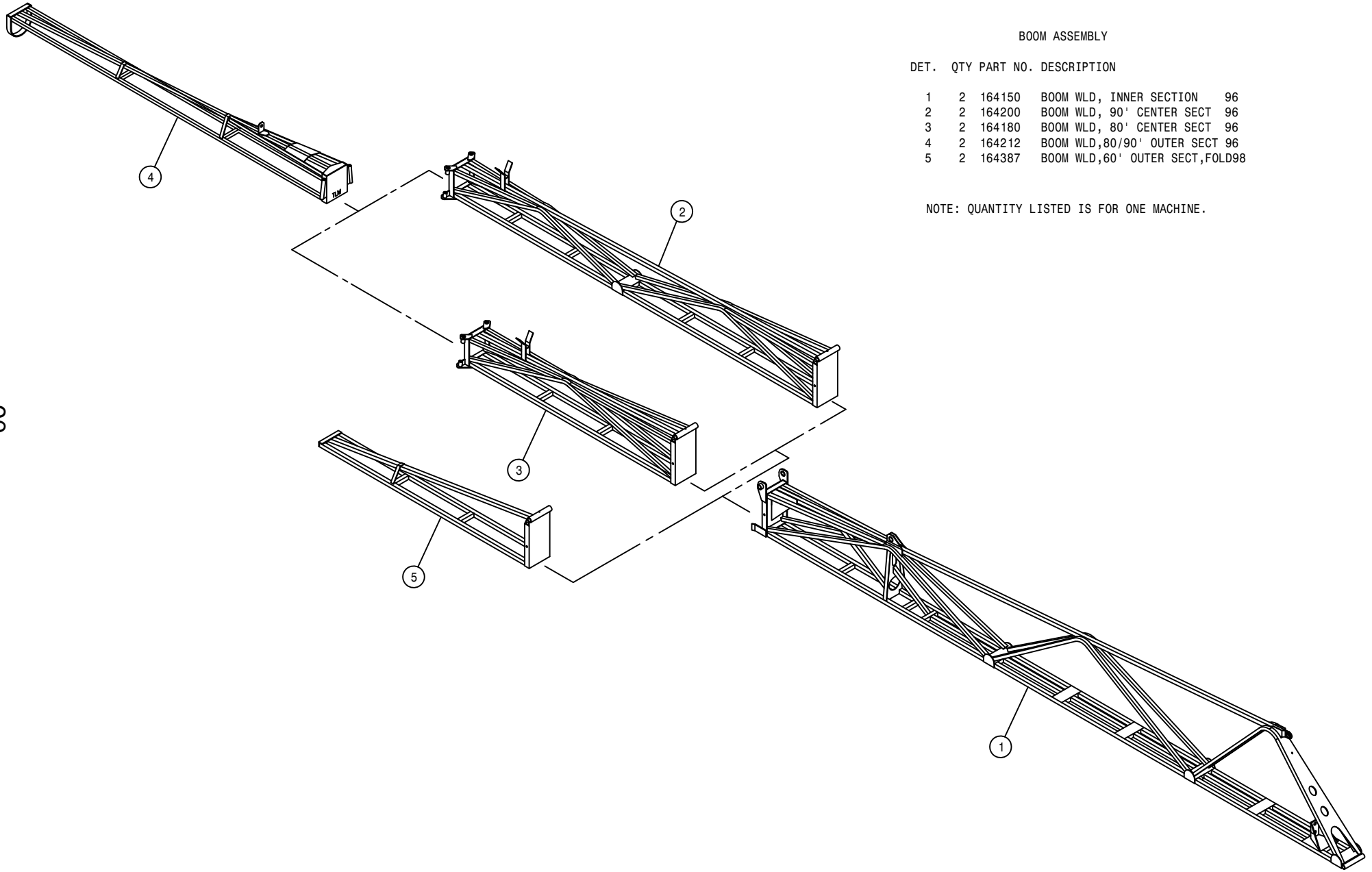

BOOM ASSEMBLY

DET.	QTY	PART NO.	DESCRIPTION	
1	2	164150	BOOM WLD, INNER SECTION	96
2	2	164200	BOOM WLD, 90' CENTER SECT	96
3	2	164180	BOOM WLD, 80' CENTER SECT	96
4	2	164212	BOOM WLD, 80/90' OUTER SECT	96
5	2	164387	BOOM WLD, 60' OUTER SECT, FOLD98	

NOTE: QUANTITY LISTED IS FOR ONE MACHINE.

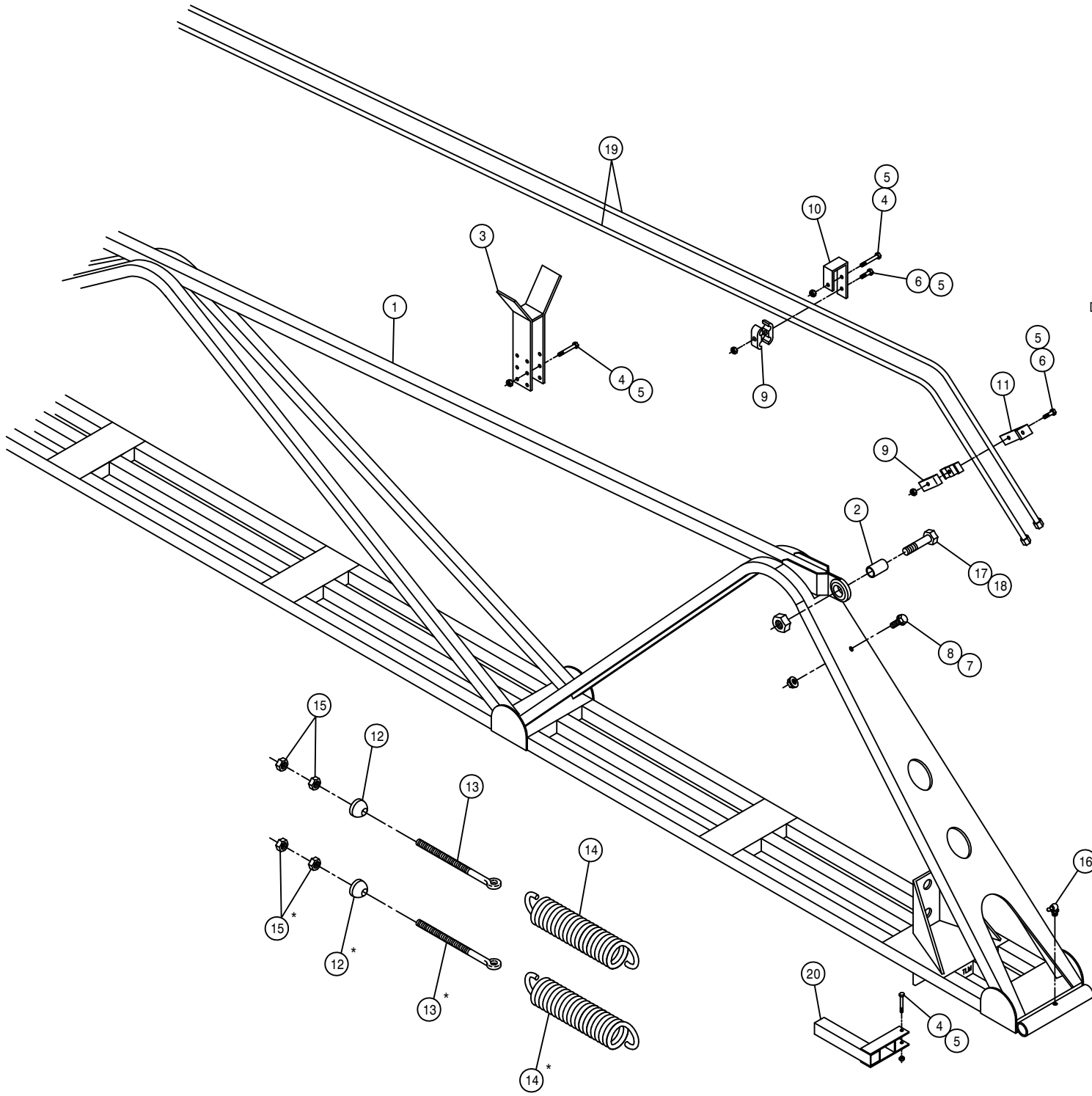

INNER BOOM ASSEMBLY

DET.	QTY	PART NO.	DESCRIPTION	
1	2	164150	BOOM WLD, INNER SECTION	96
2	2	164227	BOOM BALL JOINT BUSH	96
3	2	164266	OUTER BOOM SUPP WLD, 80/90'	96
4	18	900007	1/4UNC X 2" HEX BOLT	
5	28	914000	1/4UNC HEX STOVER NUT	
6	10	900004	1/4UNC X 1 1/4 HEX BOLT	
7	2	470121	1/4UNC HEX FLANGE LOCK NUT	
8	2	470118	1/4UNC X 3/4 FLANGE HEX BOLT	
9	10	470287	TUBE CLAMP, .375-.375 (PAIR)	
10	8	164242	HYD TUBE HANGER CLEVIS, BOOM96	
11	2	164243	HYD TUBE HANGER ANGLE, BOOM 96	
12	4	164263	SWIVEL, 5/8 BOOM EYEBOLT	
13	4	164265	5/8UNC X 7 1/2 EYE BOLT	
14	4	482014	SPRING, 3.25 X 11.50 EXTENSION	
15	8	910010	5/8UNC HEX NUT	
16	2	471028	GREASE ZERK, 1/4-28 90DEG	
17	2	900844	5/8UNC X 2 3/4 HEX BOLT GR8	
18	2	914010	5/8UNC HEX STOVER NUT	
19	4	615684	HYD TUBE ASSY, BOOM EXT FOLD96	
20	2	164275	NOZL MT WLD	96

NOTE: QUANTITY LISTED IS FOR ONE MACHINE.  
 \*60 FOOT BOOM USES ONE SPRING SETUP.

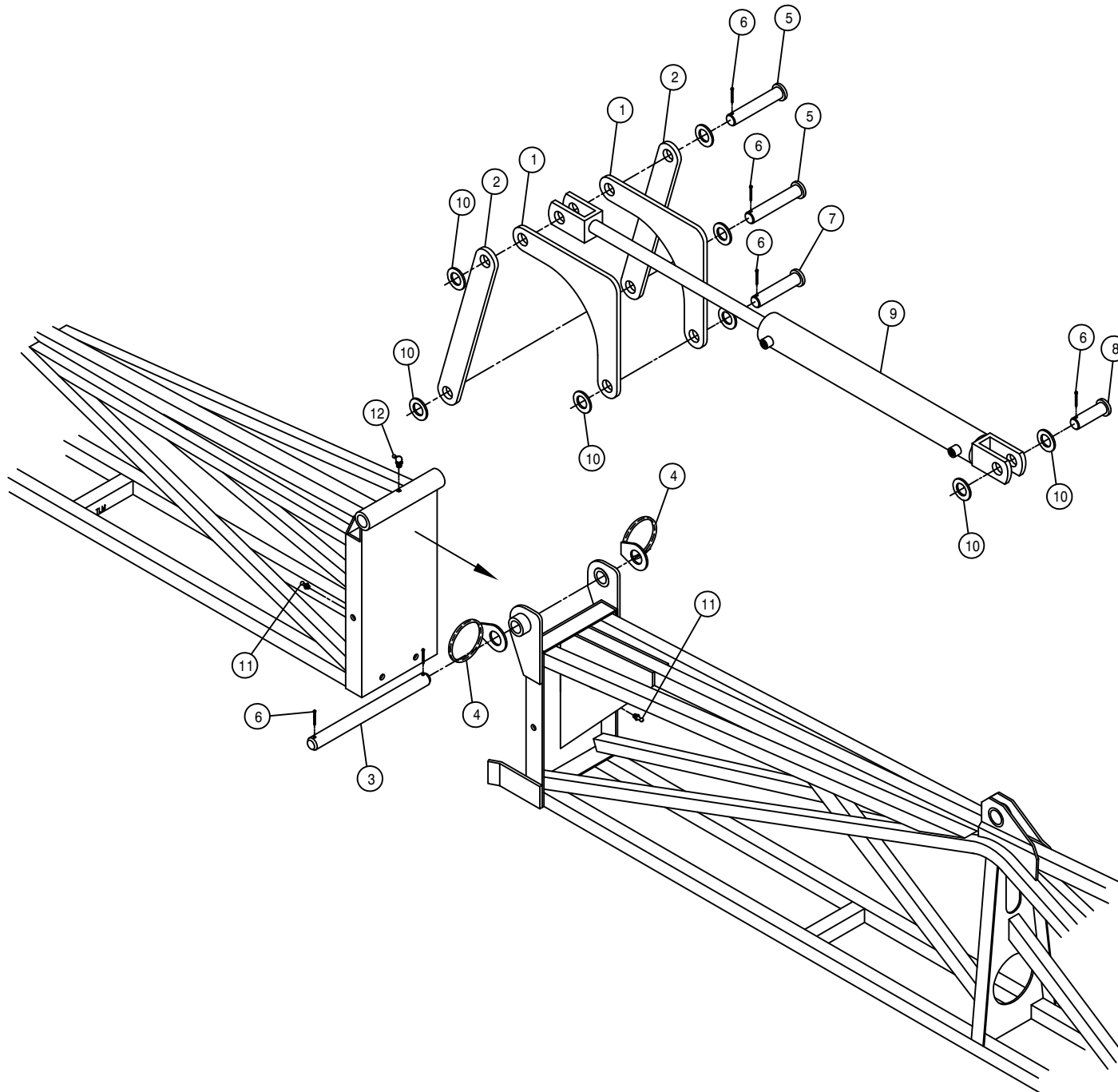

80' -90' BOOM HINGE PIVOT ASSEMBLY

DET. QTY PART NO. DESCRIPTION

1	4	164228	FOLDING LINK, INNER BOOM	96
2	4	164229	FOLDING LINK, BOOM CNTR SECT	96
3	2	164231	BOOM PIN, 1.00 X 11.75	96
4	4	438302	HOSE SUPPORT RING WLD W/WASHER	
5	4	470155	CLEVIS PIN, 1.00 X 4.00	PLT
6	12	470162	COTTER PIN 3/16 X 1 1/2	SQCUT
7	2	472012	CLEVIS PIN, 1.00 X 3.25	PLT
8	2	472270	CLEVIS PIN, 1.00 X 2.50	PLT
9	2	621020	BOOM CNTR SECT FOLD CYL ASSY	
10	16	920008	1" SAE FLAT WASHER	
11	4	471005	1/4 28 X 1/2 GREASE ZERK	
12	2	471028	GREASE ZERK, 1/4-28 90DEG	

NOTE: QUANTITY LISTED IS FOR ONE MACHINE.

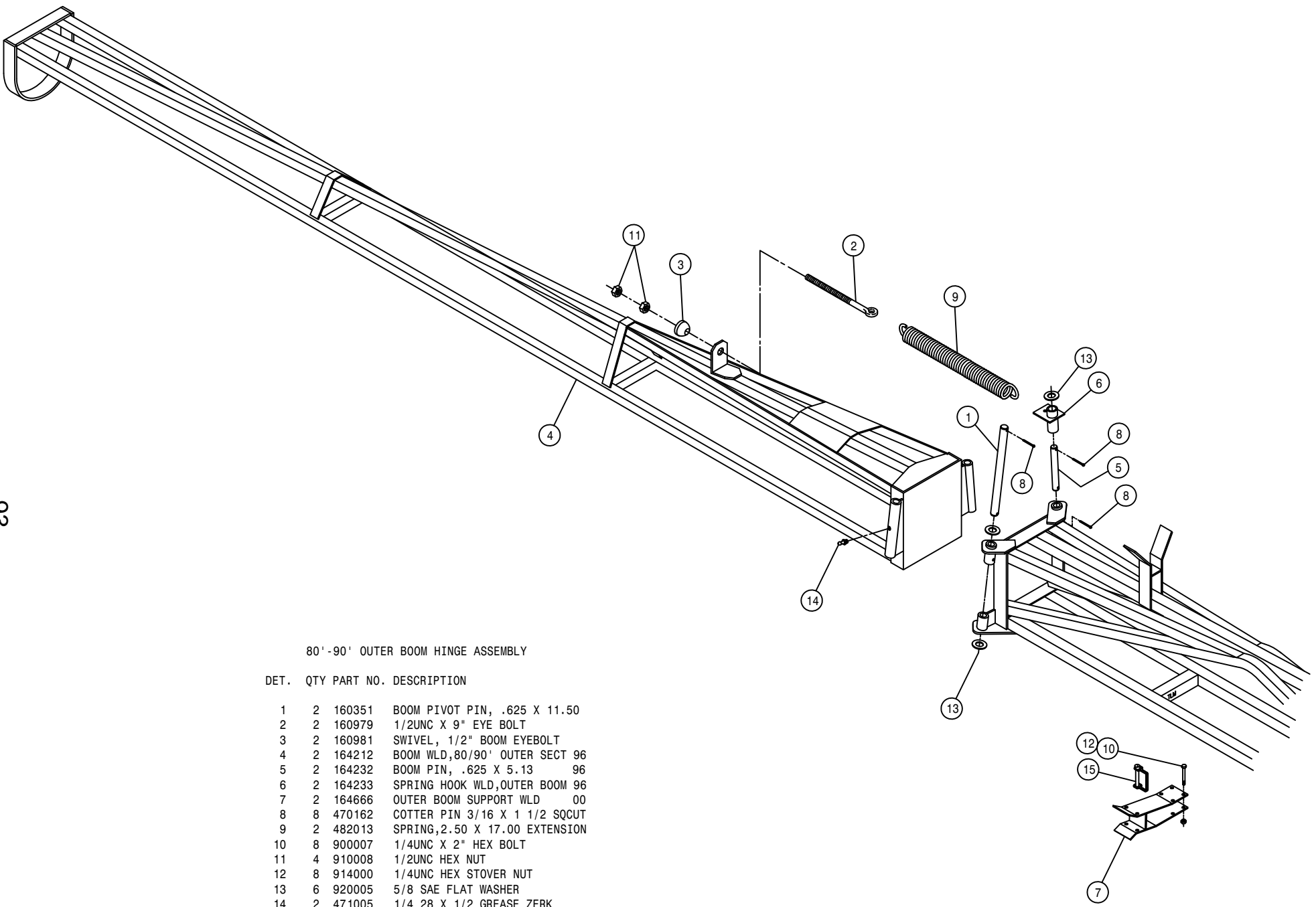

80'-90' OUTER BOOM HINGE ASSEMBLY

DET. QTY PART NO. DESCRIPTION

1	2	160351	BOOM PIVOT PIN, .625 X 11.50
2	2	160979	1/2UNC X 9" EYE BOLT
3	2	160981	SWIVEL, 1/2" BOOM EYEBOLT
4	2	164212	BOOM WLD,80/90' OUTER SECT 96
5	2	164232	BOOM PIN, .625 X 5.13 96
6	2	164233	SPRING HOOK WLD, OUTER BOOM 96
7	2	164666	OUTER BOOM SUPPORT WLD 00
8	8	470162	COTTER PIN 3/16 X 1 1/2 SQ CUT
9	2	482013	SPRING, 2.50 X 17.00 EXTENSION
10	8	900007	1/4UNC X 2" HEX BOLT
11	4	910008	1/2UNC HEX NUT
12	8	914000	1/4UNC HEX STOVER NUT
13	6	920005	5/8 SAE FLAT WASHER
14	2	471005	1/4 28 X 1/2 GREASE ZERK
15	2	473895	1/4 X 1 3/4 LYNCH PIN

NOTE: QUANTITY LISTED IS FOR ONE MACHINE.

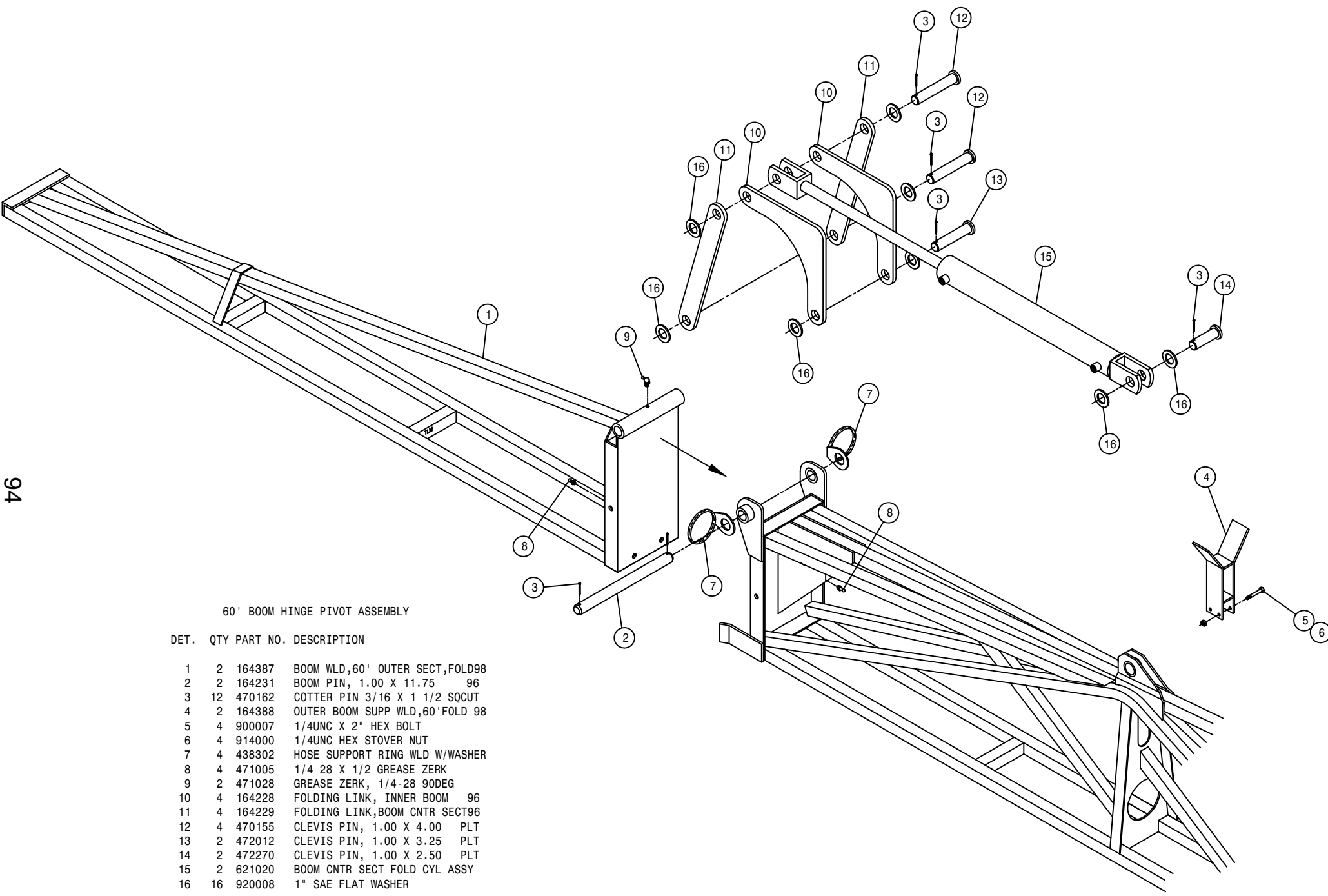

60' BOOM HINGE PIVOT ASSEMBLY

DET.	QTY	PART NO.	DESCRIPTION
1	2	164387	BOOM WLD,60' OUTER SECT,FOLD98
2	2	164231	BOOM PIN, 1.00 X 11.75 96
3	12	470162	COTTER PIN 3/16 X 1 1/2 SQCUT
4	2	164388	OUTER BOOM SUPP WLD,60'FOLD 98
5	4	900007	1/4UNC X 2" HEX BOLT
6	4	914000	1/4UNC HEX STOVER NUT
7	4	438302	HOSE SUPPORT RING WLD W/WASHER
8	4	471005	1/4 28 X 1/2 GREASE ZERK
9	2	471028	GREASE ZERK, 1/4-28 90DEG
10	4	164228	FOLDING LINK, INNER BOOM 96
11	4	164229	FOLDING LINK,BOOM CNTR SECT96
12	4	470155	CLEVIS PIN, 1.00 X 4.00 PLT
13	2	472012	CLEVIS PIN, 1.00 X 3.25 PLT
14	2	472270	CLEVIS PIN, 1.00 X 2.50 PLT
15	2	621020	BOOM CNTR SECT FOLD CYL ASSY
16	16	920008	1" SAE FLAT WASHER

NOTE: QUANTITY LISTED IS FOR ONE MACHINE.

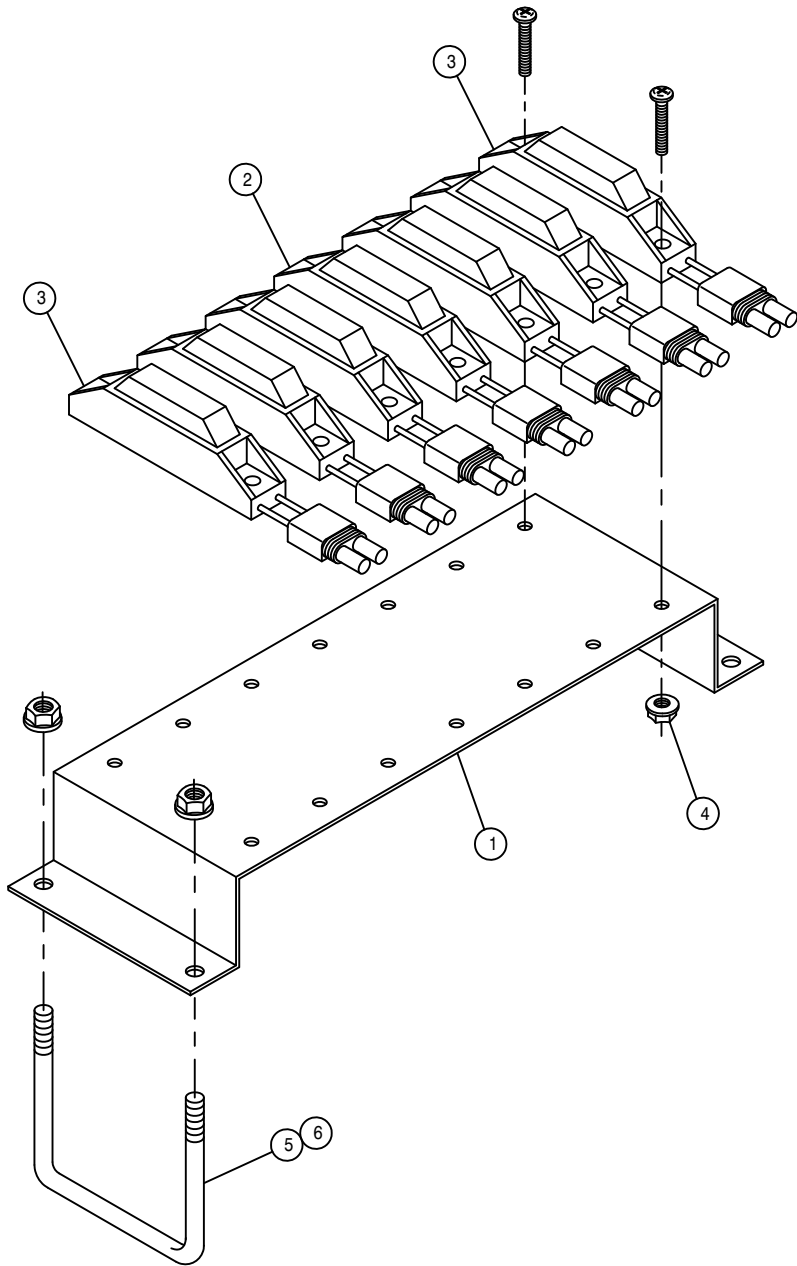

BOOM SECTION LIGHT ASSEMBLY

DET. QTY PART NO. DESCRIPTION

1	1	164386	BOOM SECT ID LIGHT BRKT2100 98
2	5	293396	RED BOOM SECT ID LIGHT ASSY
3	2	293397	YELLOW BOOM SECT ID LIGHT ASSY
4	14	470175	10-32 HEX FLANGE LOCK NUT
5	2	473970	1/4UNC-1 1/16ID-2 3/4 U-BOLTSQ
6	4	470121	1/4UNC HEX FLANGE LOCK NUT

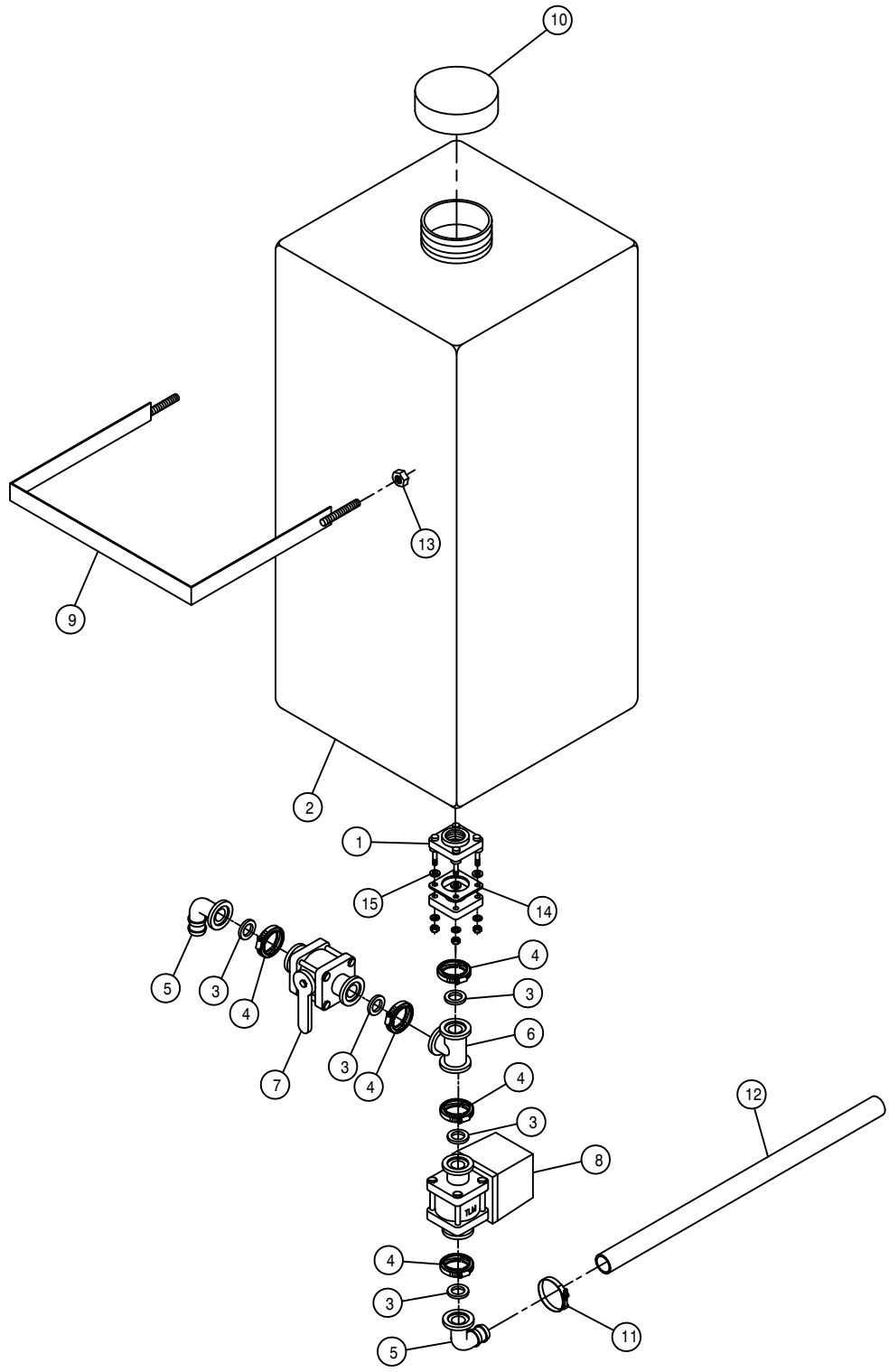

RINSE TANK ASSEMBLY

DET.	QTY	PART NO.	DESCRIPTION
	1	500178	1"FLG TANK FTG,BOTDRN BLT POLY
	1	763475	55 GAL TANK, RECTANGLE VERTICL
	5	500157	1" FLANGE GASKET EPDM
	5	500159	1" FLANGE CLAMP, S.S.
	2	500173	1" FLANGE-90-1" HOSE BARB POLY
	1	500175	1" FLANGE TEE POLY
	1	696147	BALL VLV, 1" FLANGE
	1	696177	ELECT BALL VLV,1"FLANGE TJET
	1	342621	RINSE TANK BAND WLD, 2100 98
	1	763474	LID, 55 GAL RINSE TANK 763475
	1	520138	1.38/1.56 T-BOLT HOSE CLAMP
	1	601425	HOSE, 1 X 192 2F-1W EPDM
	2	914008	1/2UNC HEX STOVER NUT
	1	500221	FULL GASKET,1" TANK FTG 500178
	4	500222	FOOT GASKET,1" TANK FTG 500178



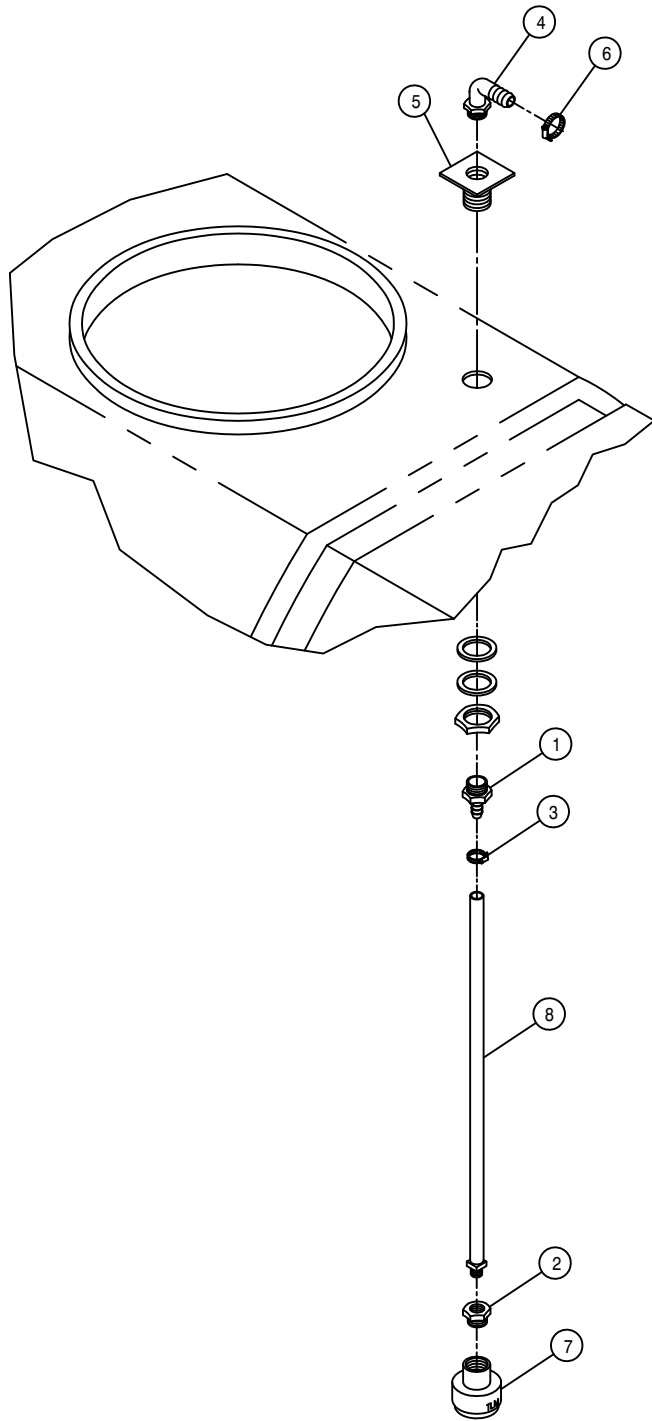

RINSE NOZZLE ASSEMBLY

DET. QTY PART NO. DESCRIPTION

1	2	500027	3/4NPT-3/8 HOSE BARB, POLY
2	2	504002	RED BUSH 3/4 TO 1/4, POLY
3	2	520120	HOSE CLAMP NO 4 STAINLESS
4	2	500054	3/4NPT-90-3/4 HOSE BARB, POLY
5	2	618549	.75 PLASTIC FTG ASSY POLY TNK
6	2	520055	HOSE CLAMP NO 12 STAINLESS
7	2	737873	ROTARY NOZZLE, TEFLON
8	2	737821	QUICK TEEJET HOSE DROP 24IN

NOTE: QUANTITY LISTED IS FOR ONE MACHINE.

FOAM MARKER TANK ASSEMBLY

DET. QTY PART NO. DESCRIPTION

NOTE: 1. DETAIL 28 AND 29 ARE USED WITH THE 60 FT BOOM.  
 2. DETAIL 30 AND 31 ARE USED WITH THE 80 FT BOOM.  
 3. DETAIL 32 AND 33 ARE USED WITH THE 90 FT BOOM.

1	3	293056	ROMEX CONNECTOR .50IN 2-SCR
2	2	701150	3/4NPT-90-3/4HBRB, TAPPED, POLY
3	1	502705	1/4NPT-90-1/4NPT LBO, BRS
4	1	505205	BLK PIPE NIPPLE 1.00NPT-5.00
5	2	505211	3/8-1/4NPT REDU BUSH, BRS
6	3	520120	HOSE CLAMP NO 4 STAINLESS
7	1	601419	HOSE, 3/8 X 30 CLEAR VINYL
8	1	601420	HOSE, 3/8 X 48 CLEAR VINYL
9	1	618571	1/4MNPT-90-1/4MNPT LBO
10	1	695900	BALL VALVE 1IN FNPT POLY
11	2	696120	BALL VALVE, 1/4NPT, STEEL
12	1	696134	BALL VALVE 2IN FNPT POLY
13	2	696163	3/4" ELECT SOLENOID VALVE
14	1	701143	FOAMER AIR TUBE FTG
15	1	701112	FOAM MARKER TANK, 36 GAL SS
16	1	711015	1/4MNPT-1/4OD NYL TUBE FTGBRS
17	1	711050	3/4"FNPT CHECK VALVE S.S.
18	1	783304	1/4 NPT X 3/8 HOSE BARB, BRS
19	4	193002	SPIRAL PROTECTIVE WRAP, BLACK
20	2	342333	NYL HOSE SLEEVE, 2.64ID X 12.00
21	4	342623	FOAMER TANK BAND WLD, 2100 98
22	2	500069	3/4-90-3/4 HOSE BARB, POLY
23	6	520055	HOSE CLAMP NO 12 STAINLESS
24	2	900138	3/8UNC X 3 1/2 HEX BOLT
25	6	914004	3/8UNC HEX STOVER NUT
26	2	920002	3/8 SAE FLAT WASHER
27	2	195908	HOSE, 3/4ID-1/8W CLEAR VINYL X 275.00
28	1	195908	HOSE, 3/4ID-1/8W CLEAR VINYL X 580.00
29	1	195908	HOSE, 3/4ID-1/8W CLEAR VINYL X 684.00
30	1	195908	HOSE, 3/4ID-1/8W CLEAR VINYL X 780.00
31	1	195908	HOSE, 3/4ID-1/8W CLEAR VINYL X 804.00
32	1	195908	HOSE, 3/4ID-1/8W CLEAR VINYL X 840.00
33	1	195908	HOSE, 3/4ID-1/8W CLEAR VINYL X 864.00
34	1	601418	HOSE, 1/4 X 228 AIR
35	1	507021	SS PIPE NIPPLE, 1/8NPT X 6"
36	1	500202	SS PIPE CPLG, 1/8NPT .563 OD
37	1	701144	FOAMER AIR NOZZLE
38	1	342658	FOAMER TANK SUPP WLD, 2100 98
39	1	910008	1/2UNC HEX NUT
40	2	920504	1/2 LOCK WASHER
41	1	914008	1/2UNC HEX STOVER NUT
42	2	701151	3/8PIPE PLUG, .187 ORIFICE, POLY
43	2	507724	REDU BUSH 3/4MNPT X 1/4FNPT, SS

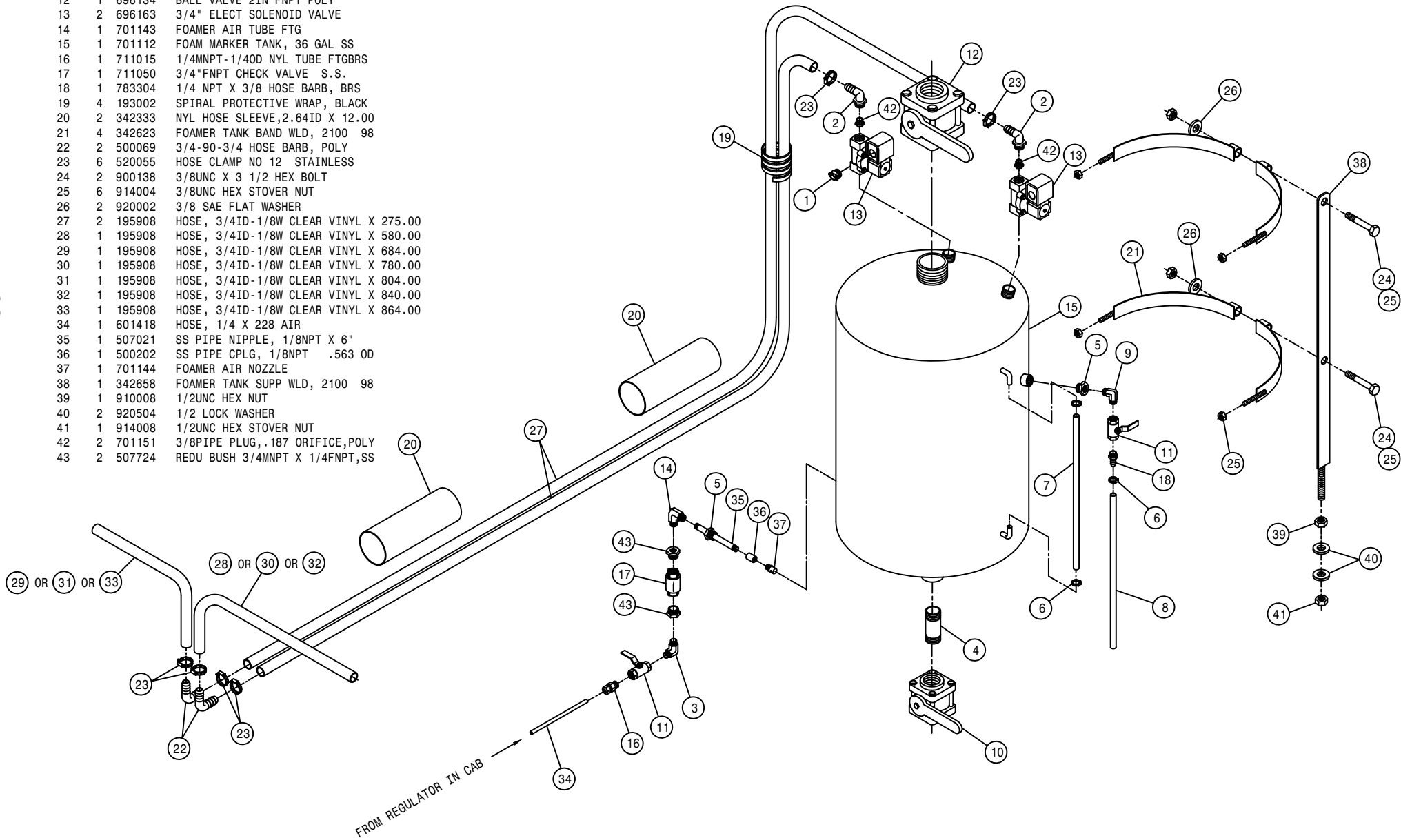

98

225098

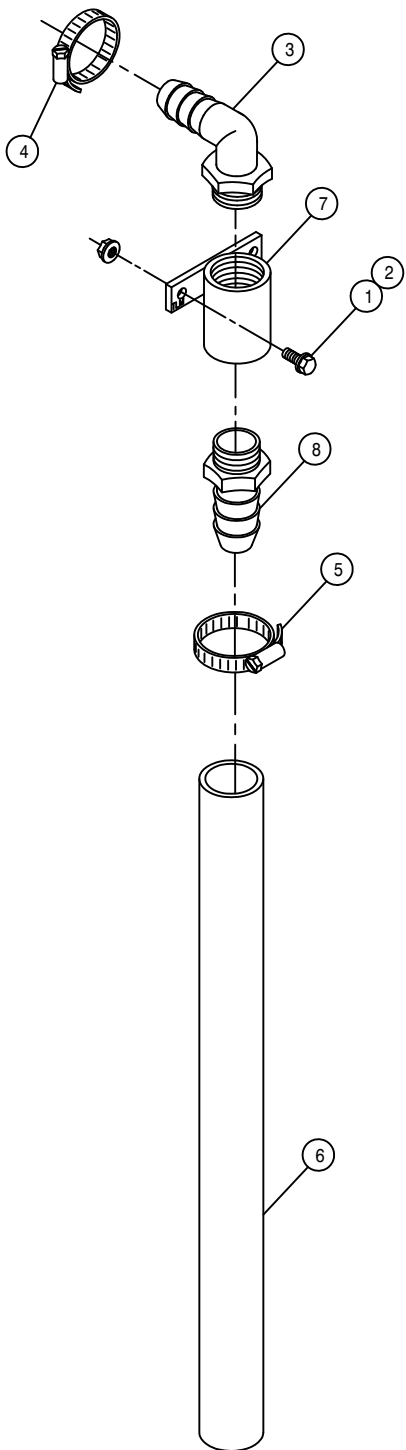

FOAMER DROP END ASSEMBLY

DET. QTY PART NO. DESCRIPTION

1	4	470118	1/4UNC X 3/4 FLANGE HEX BOLT
2	4	470121	1/4UNC HEX FLANGE LOCK NUT
3	2	500067	1 NPT-90-3/4 HOSE BARB, POLY
4	2	520055	HOSE CLAMP NO 12 STAINLESS
5	2	520085	HOSE CLAMP NO 24 STAINLESS
6	2	601367	HOSE, 1 1/4 X 24 2BR BLK EPDM
7	2	701102	FOAM MARKER DROP CPLR WELD
8	2	714561	1.00NPT-1.25 HOSE BARB

NOTE: QUANTITY LISTED IS FOR ONE MACHINE.

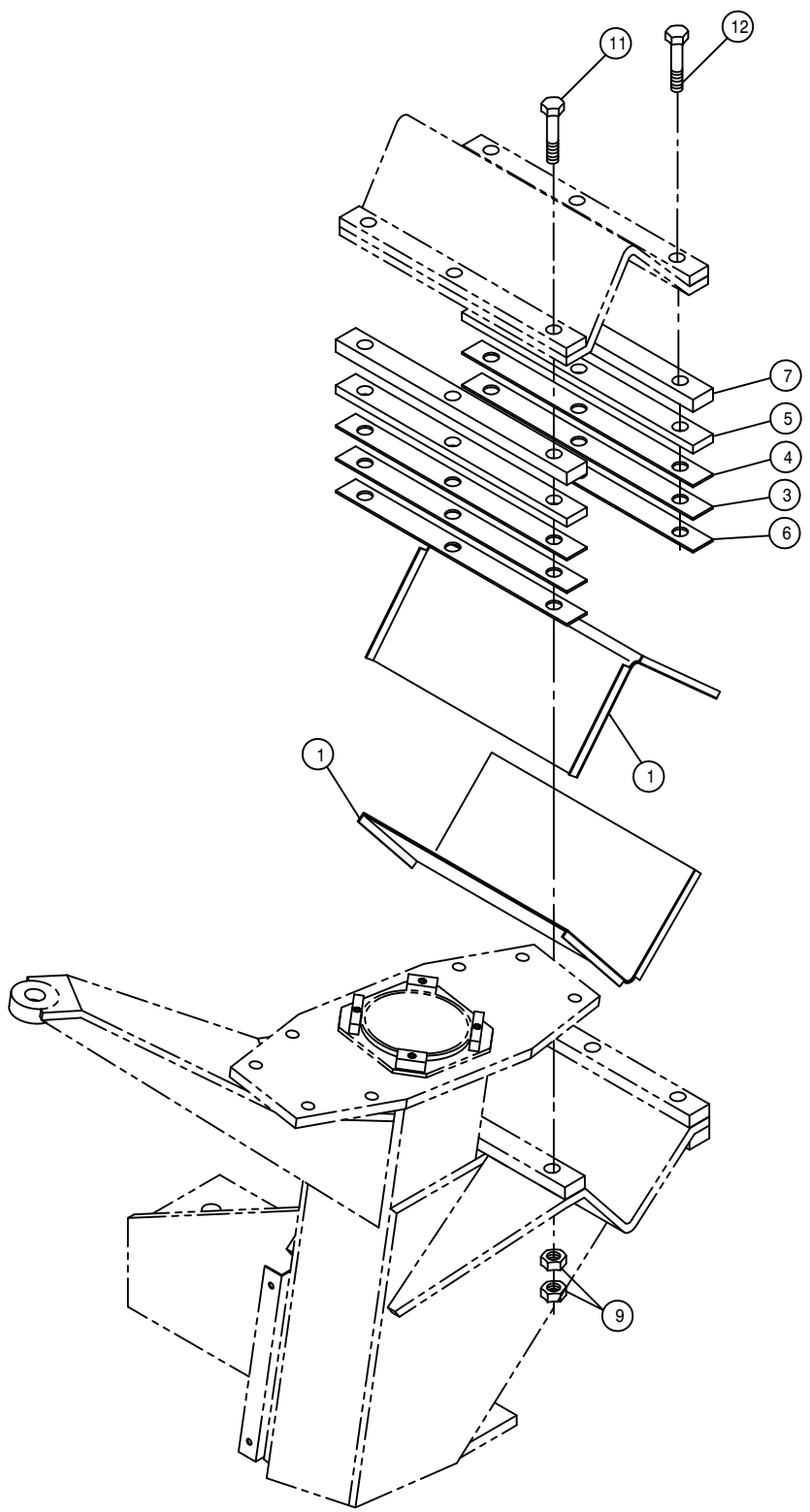

TREAD ADJUSTMENT ASSEMBLY

DET.	QTY	PART NO.	DESCRIPTION
1	8	358703	TREAD ADJ XMBR BEARING ASSY
2	4	358939	TREAD ADJ CYL EXT, 144" 2100 98
3	16	358767	.025 LEG MT SHIM, 284T 94
4	4	358752	.074 LEG MT SHIM, 284T 94
5	8	358769	.250 LEG MT SHIM, 284T 94
6	8	358768	.037 LEG MT SHIM, 284T 94
7	8	358766	.375 LEG MT SPACER, 284T 94
8	4	900268	1/2UNC X 2 1/2 HEX BOLT
9	48	914811	5/8UNF HEX NUT GR8
10	4	900267	1/2UNC X 2" HEX BOLT
11	12	900837	5/8UNF X 3 1/2 HEX BOLT GR8
12	12	900838	5/8UNF X 4" HEX BOLT GR8
13	8	914008	1/2UNC HEX STOVER NUT
14	4	358944	TREAD ADJ CYL EXT, 154" 2100 98

NOTE: QUANTITY LISTED IS FOR ONE MACHINE.

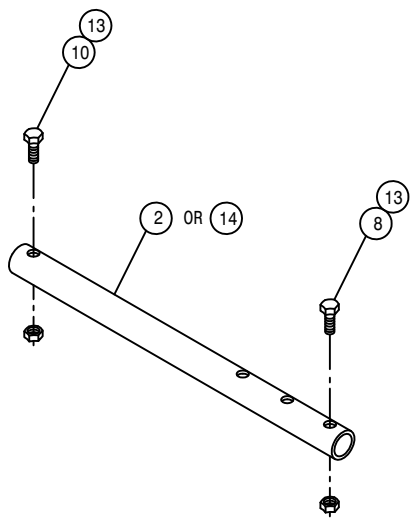

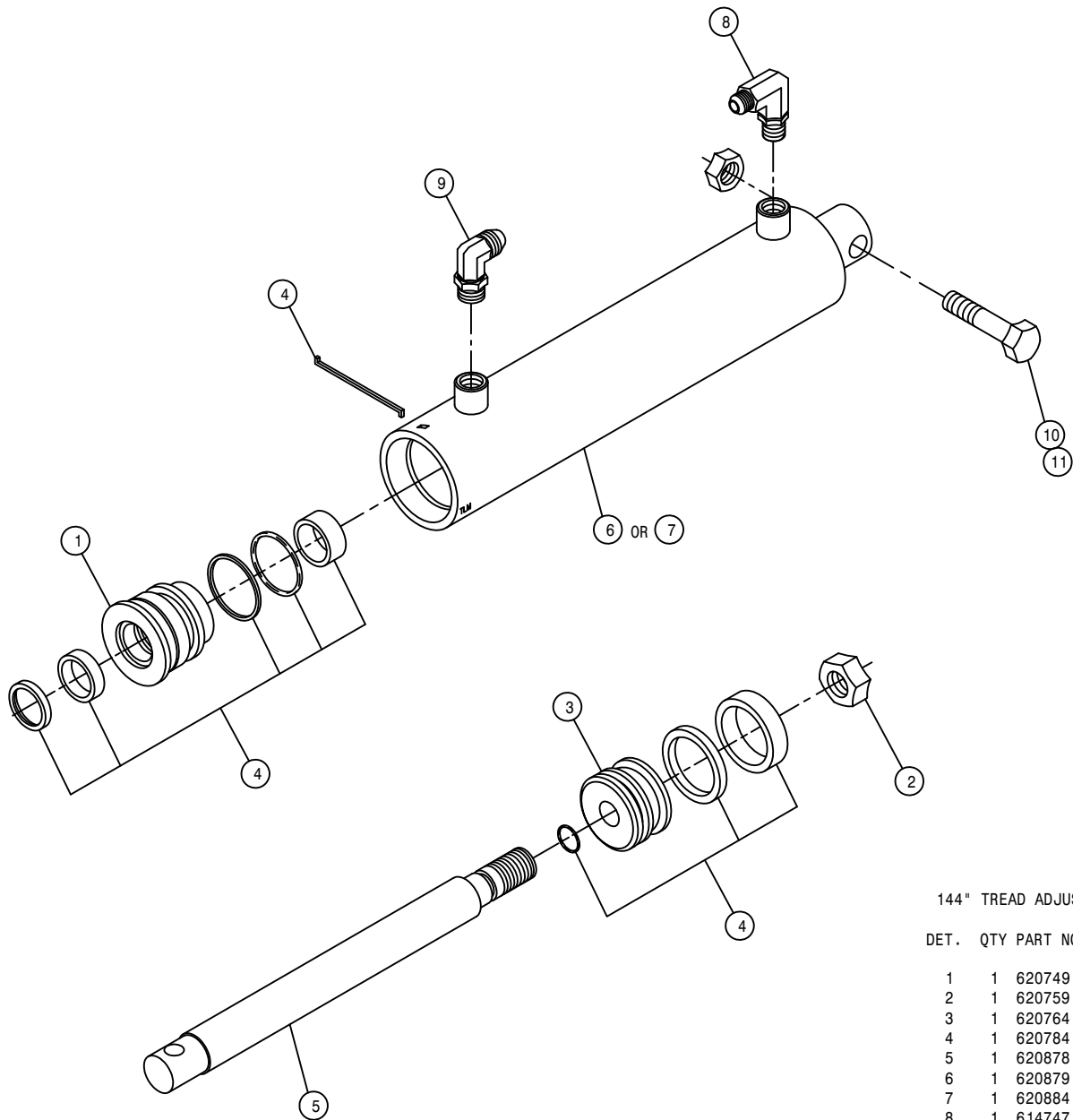

144" TREAD ADJUSTMENT LEG CYLINDER ASSEMBLY

DET.	QTY	PART NO.	DESCRIPTION
	1	620749	HEAD, H-2.50-352
	1	620759	NUT, N-0.75-01
	1	620764	PISTON, P-2.50-107
	1	620784	REPAIR KIT, HYD CYL, RK-2.50-801
	1	620878	SHAFT, LEG CYL, TRD ADJ 620875
	1	620879	BARREL, LEG CYL, TRD ADJ 620875
	1	620884	BARREL, LEG CYL, TRD ADJ 620880
	1	614747	.025 ELBOW ASSY, 9/16MOR 90D
	1	618119	9/16MJIC-90-9/16MOR LBO
	1	900268	1/2UNC X 2 1/2 HEX BOLT
	1	914008	1/2UNC HEX STOVER NUT

NOTE: 1. 620880 - RH LEG 144" TREAD ADJ CYL ASSEMBLY INCLUDES ITEMS 1-5 & 7  
 2. 620875 - LH LEG 144" TREAD ADJ CYL ASSEMBLY INCLUDES ITEMS 1-5 & 6  
 3. 621028 - RH LEG 144" TREAD ADJ CYLINDER ASSEMBLY WITH FITTINGS  
 4. 621027 - LH LEG 144" TREAD ADJ CYLINDER ASSEMBLY WITH FITTINGS

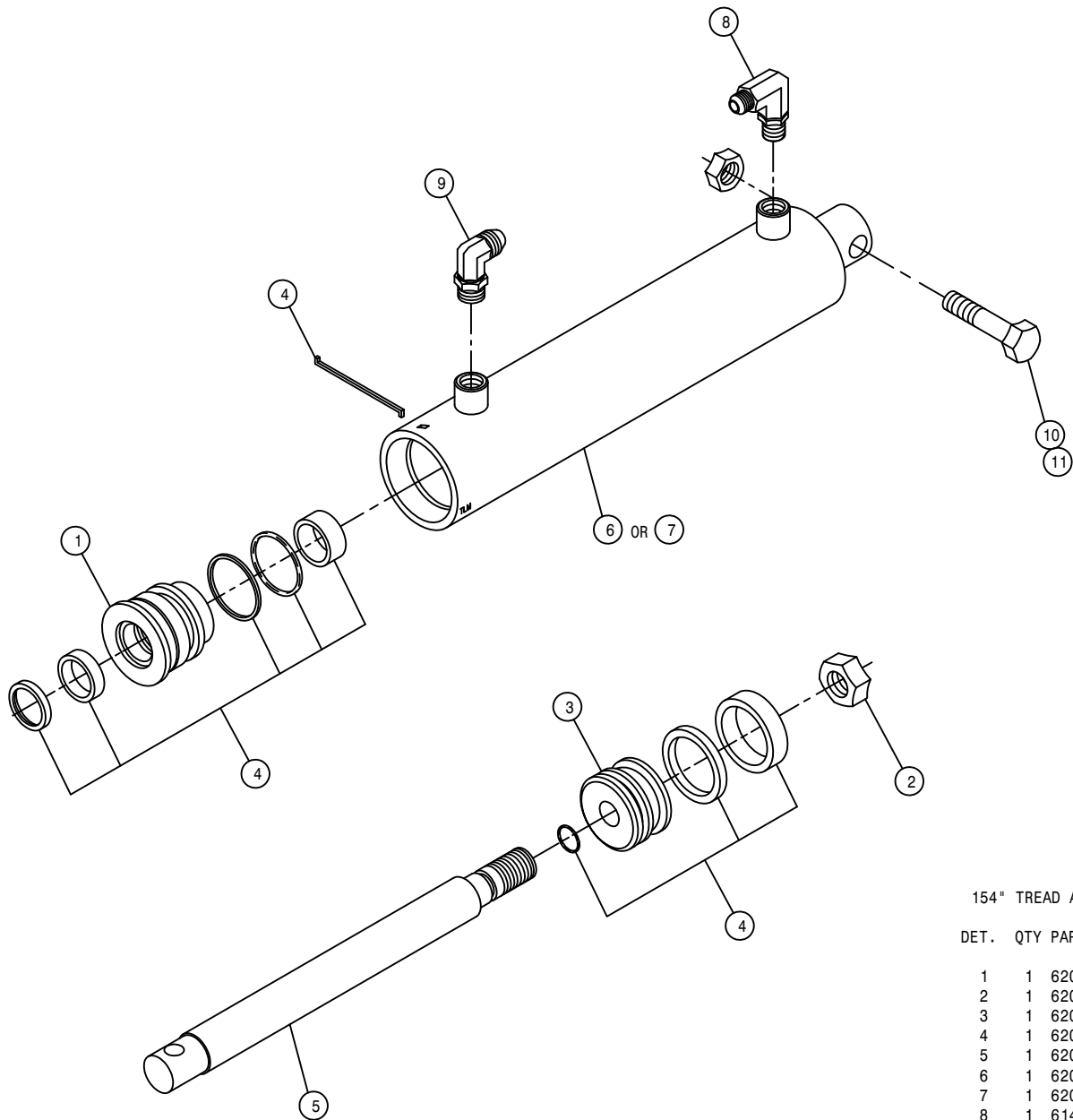

154" TREAD ADJUSTMENT LEG CYLINDER ASSEMBLY

DET.	QTY	PART NO.	DESCRIPTION
	1	620749	HEAD, H-2.50-352
	1	620759	NUT, N-0.75-01
	1	620764	PISTON, P-2.50-107
	1	620784	REPAIR KIT, HYD CYL, RK-2.50-801
	1	620888	SHAFT, LEG CYL, TRD ADJ 620885
	1	620894	BARREL, LEG CYL, TRD ADJ 620890
	1	620889	BARREL, LEG CYL, TRD ADJ 620885
	1	614747	.025 ELBOW ASSY, 9/16MOR 90D
	1	618119	9/16MJIC-90-9/16MOR LBO
	1	900268	1/2UNC X 2 1/2 HEX BOLT
	1	914008	1/2UNC HEX STOVER NUT

NOTE: 1. 620885 - RH LEG 144" TREAD ADJ CYL ASSEMBLY INCLUDES ITEMS 1-5 & 7  
 2. 620890 - LH LEG 144" TREAD ADJ CYL ASSEMBLY INCLUDES ITEMS 1-5 & 6  
 3. 621029 - RH LEG 144" TREAD ADJ CYLINDER ASSEMBLY WITH FITTINGS  
 4. 621030 - LH LEG 144" TREAD ADJ CYLINDER ASSEMBLY WITH FITTINGS

ELECTRIC TREAD ADJUST VALVE ASSEMBLY

DET. QTY PART NO. DESCRIPTION

1	9	473821	#10 INT TOOTH WASHER
2	1	610447	HYD FILTER, INLINE 1/4FNPT 90M
3	1	610459	90M FILTER & GASKET FOR 610447
4	1	610462	GASKET FOR 610447 ARROW FILTER
5	1	610656	5 SECT, 4 FUNCTN HYD VLV, EATON
6	4	610574	VALVE SECTION ASSY FOR 610569
7	9	610575	SOLENOID COIL ASSY FOR 610569
8	9	610576	SOLENOID CASE FOR 610569
9	9	610577	SOLENOID CASE NUT FOR 610569
10	8	610578	SECTION O-RING FOR 610569
11	1	611122	9/16MJIC-90-1/4MNPT LBO
12	9	618119	9/16MJIC-90-9/16MOR LBO
13	1	618562	9/16MOR-90-1/4MNPT LBO
14	9	910027	10-32 HEX NUT
15	4	470118	1/4UNC X 3/4 FLANGE HEX BOLT
16	4	470121	1/4UNC HEX FLANGE LOCK NUT
17	1	610630	UNLOAD SECTION ASSY FOR 610569
18	1	610727	UNLOAD SPOOL FOR EATON 610630
19	4	610728	MOTOR SPOOL FOR EATON 610574
20	5	610729	SPOOL SPRING FOR EATON 610574
21	9	610730	SOLE PLUNGER FOR EATON 610574
22	9	610731	SOLE S/A CORE FOR EATON 610574
23	9	610732	O-RING FOR EATON 610574
24	8	610733	SPRING LOCKOUT FOR EATON 610574
25	8	610734	POPPET ASSY FOR EATON 610574
26	7	610735	WASHER FOR EATON 610574
27	1	610631	SECTION ASSY, END FOR 610569

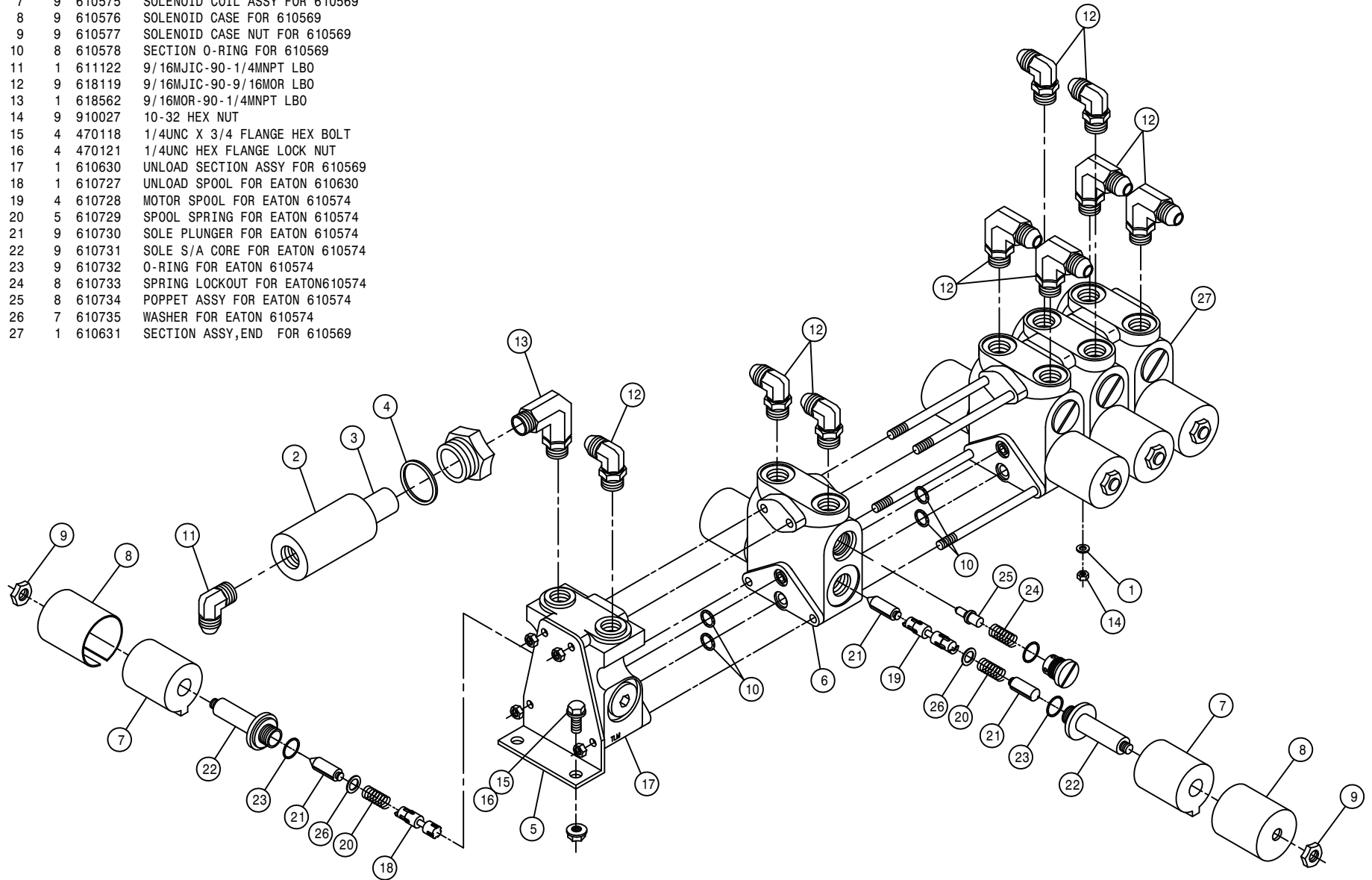

PRESSURE WASHER ASSEMBLY

DET. QTY PART NO. DESCRIPTION

DET.	QTY	PART NO.	DESCRIPTION
1	1	500072	1/2NPT-90-3/4 HOSE BARB, POLY
2	4	500157	1" FLANGE GASKET EPDM
3	4	500159	1" FLANGE CLAMP, S.S.
4	1	500170	1" FLANGE-3/4" HOSE BARB POLY
5	1	500175	1" FLANGE TEE POLY
6	2	505200	BLK PIPE ST EL 90DEG 1.00NPT
7	1	505203	BLK PIPE NIPPLE 1.00NPT-4.00
8	3	520087	HOSE CLAMP NO 20 STAINLESS
9	1	601436	HOSE, 3/4 X 15 1BR BLK EPDM
10	2	611147	3/4MJIC-1/2MNPT ADPTR
11	1	618590	3/4MJIC-45-3/4FJIC SWIV LBO
12	1	690553	PRESSURE WASHER, HYPRO 1802
13	1	690660	LINE "T" STRAINER, 1" FLANGE
14	1	690661	50 MESH SCREEN FOR 690660
15	1	696147	BALL VLV, 1" FLANGE
16	1	763520	RH PRESSURE WASHER MT, 2100 98
17	1	763521	LH PRESSURE WASHER MT, 2100 98
18	1	763526	RINSE FITTING SUPP, WASH2100 98
19	1	763532	PRESS WASH WAND MT WLD, 2100 98
20	8	900064	5/16UNC X 3/4 HEX BOLT
21	8	914002	5/16UNC HEX STOVER NUT

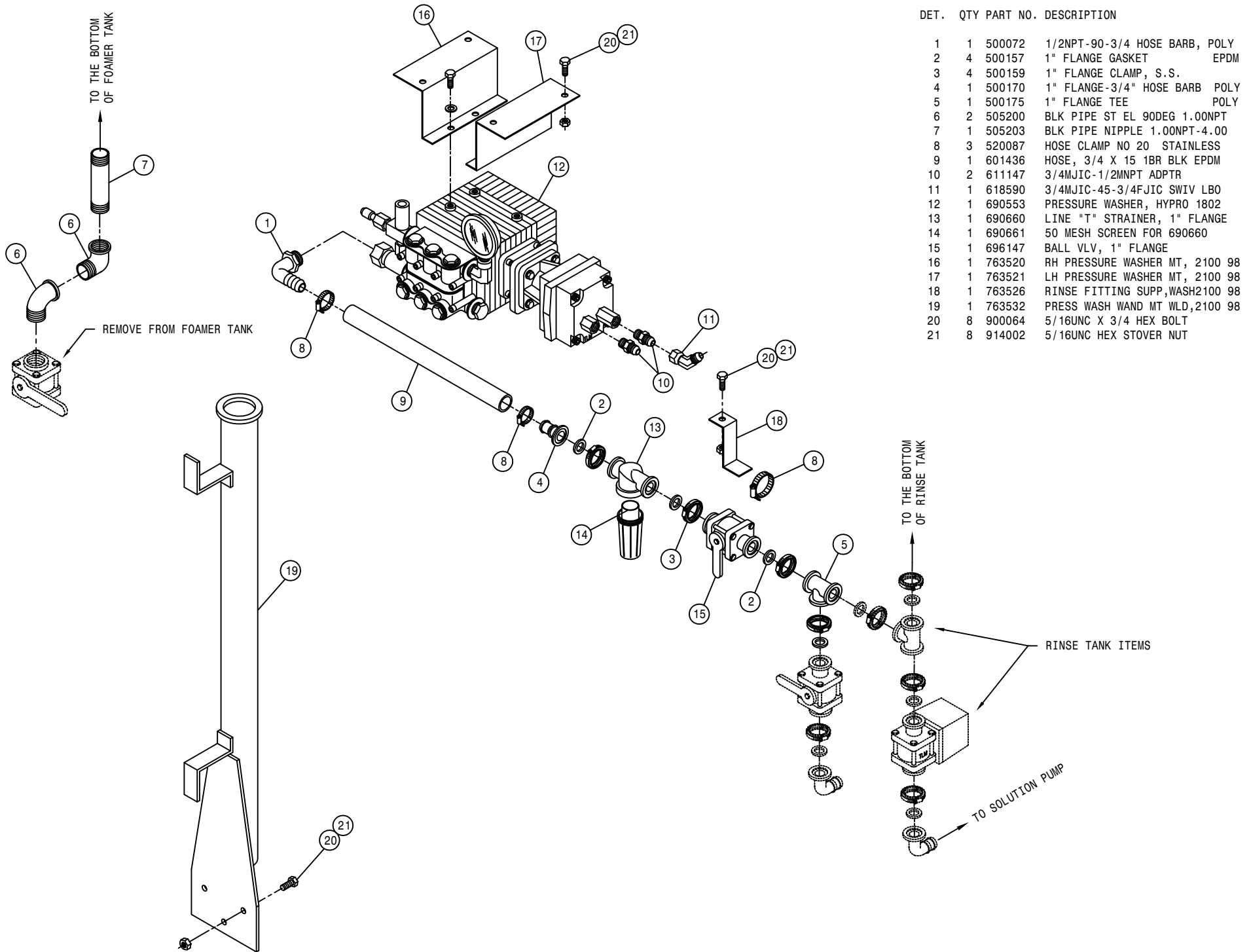



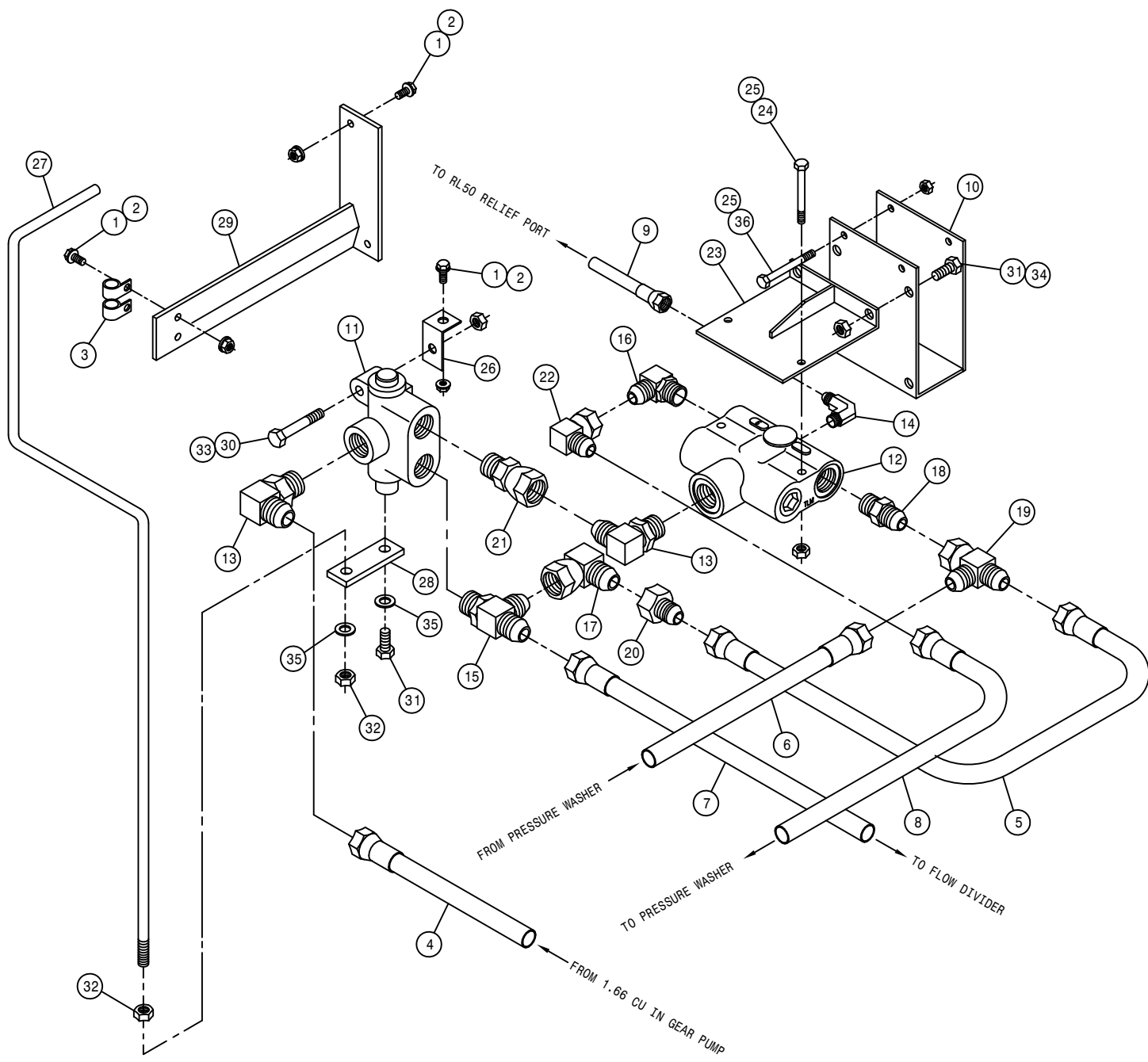

PRESSURE WASHER FLOW DIVIDER ASSEMBLY

DET.	QTY	PART NO.	DESCRIPTION
1	5	470118	1/4UNC X 3/4 FLANGE HEX BOLT
2	5	470121	1/4UNC HEX FLANGE LOCK NUT
3	2	520118	CUSH HOSE CLAMP 1/2D X 1/2W
4	1	614744	10C2AT-10FJX-10FJX-18 H/A
5	1	615385	08C1T-08FJX-08FJX-29 H/A
6	1	615465	08C1T-08FJX-08FJX-33 H/A
7	1	615741	10C1T-10FJX-10FJX-38 H/A
8	1	615742	08C1T-08FJX-08FJX-36 H/A
9	1	616043	04C1T-06FJX-06FJX-23 H/A
10	1	342311	TRACT VLV MT WLD,284 COMBO 96
11	1	690625	SELECT VLV,PRESS WASH 2100 98
12	1	607518	FLO DIV BGR56 6GPM PRI 7/8FOR
13	2	611128	7/8MJIC-90-7/8MOR LBO
14	1	618015	9/16MJIC-90-3/8MNPT LBO
15	1	618130	7/8MOR RUN TEE-7/8MJIC
16	1	618183	3/4MJIC-90-7/8MOR LBO
17	1	618301	7/8MJIC-90-7/8FJIC SWIV LBO
18	1	618327	3/4MJIC-7/8MOR ADPTR
19	1	618451	3/4FJIC SW RUN TEE-3/4MJIC
20	1	618523	7/8FJIC-3/4MJIC ADPTR
21	1	618594	7/8FJIC SWIV-7/8MOR ADPTR
22	1	618609	3/4MJIC-90-3/4FJIC SWIV LBO
23	1	763522	FLO DIV MT WLD, WASHER 2100 98
24	2	900007	1/4UNC X 2" HEX BOLT
25	4	914000	1/4UNC HEX STOVER NUT
26	1	763525	SEL VLV MT,PRESS WASH 2100 98
27	1	763527	SEL VLV HANDLE, WASHER 2100 98
28	1	763528	VLV HANDLE BRKT,WASHER 2100 98
29	1	763529	VLV HANDLE SUPP WLD,WASH210098
30	1	900067	5/16UNC X 1 1/2 HEX BOLT
31	3	900128	3/8UNC X 3/4 HEX BOLT
32	2	910004	3/8UNC HEX NUT
33	1	914002	5/16UNC HEX STOVER NUT
34	2	914004	3/8UNC HEX STOVER NUT
35	2	920502	3/8 LOCK WASHER
36	2	900010	1/4UNC X 3" HEX BOLT

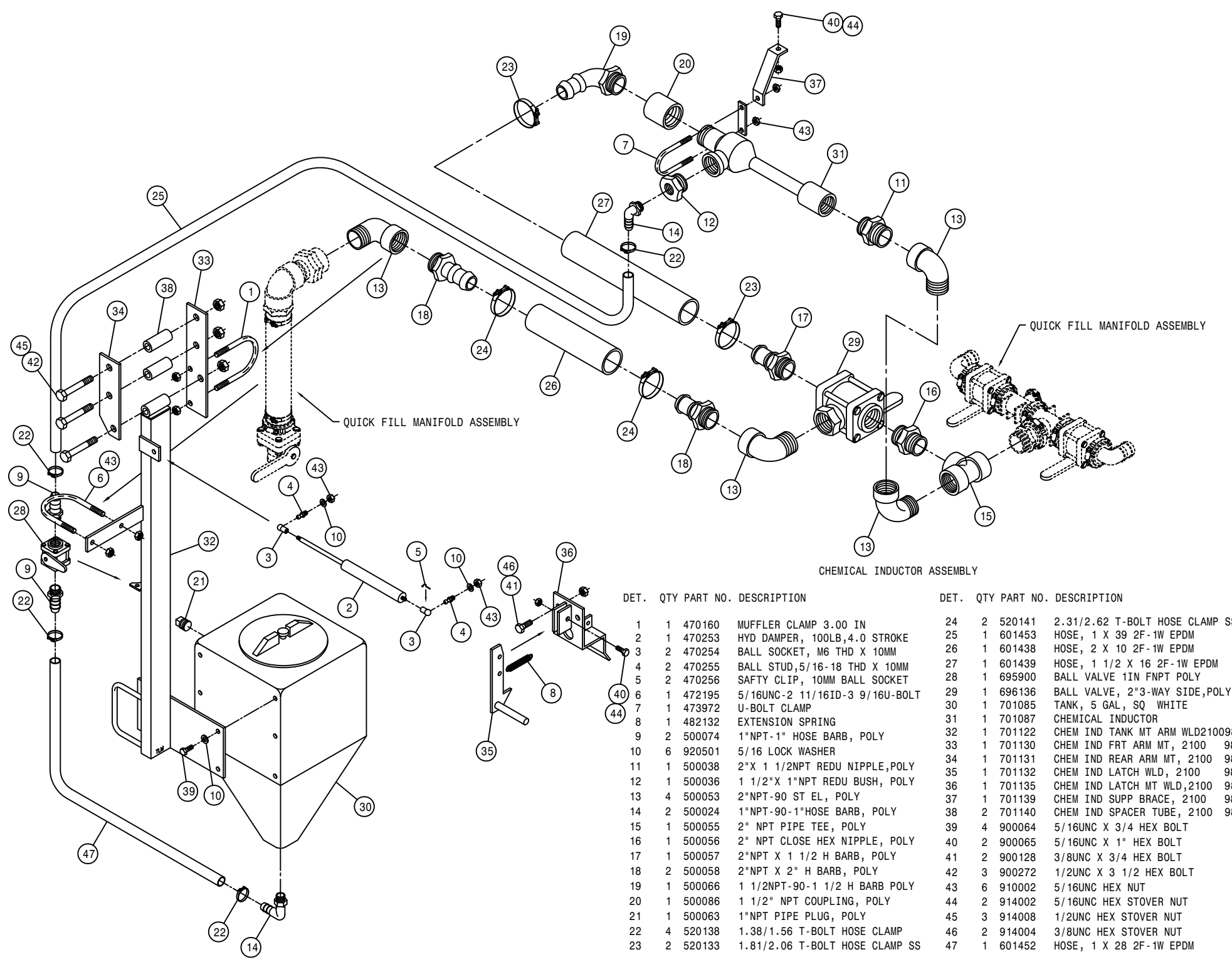

DET.	QTY	PART NO.	DESCRIPTION	DET.	QTY	PART NO.	DESCRIPTION
1	1	470160	MUFFLER CLAMP 3.00 IN	24	2	520141	2.31/2.62 T-BOLT HOSE CLAMP SS
2	1	470253	HYD DAMPER, 100LB,4.0 STROKE	25	1	601453	HOSE, 1 X 39 2F-1W EPDM
3	2	470254	BALL SOCKET, M6 THD X 10MM	26	1	601438	HOSE, 2 X 10 2F-1W EPDM
4	2	470255	BALL STUD,5/16-18 THD X 10MM	27	1	601439	HOSE, 1 1/2 X 16 2F-1W EPDM
5	2	470256	SAFTY CLIP, 10MM BALL SOCKET	28	1	695900	BALL VALVE 1IN FNPT POLY
6	1	472195	5/16UNC-2 11/16ID-3 9/16U-BOLT	29	1	696136	BALL VALVE, 2"3-WAY SIDE,POLY
7	1	473972	U-BOLT CLAMP	30	1	701085	TANK, 5 GAL, SQ WHITE
8	1	482132	EXTENSION SPRING	31	1	701087	CHEMICAL INDUCTOR
9	2	500074	1"NPT-1" HOSE BARB, POLY	32	1	701122	CHEM IND TANK MT ARM WLD210098
10	6	920501	5/16 LOCK WASHER	33	1	701130	CHEM IND FRT ARM MT, 2100 98
11	1	500038	2"X 1 1/2NPT REDU NIPPLE,POLY	34	1	701131	CHEM IND REAR ARM MT, 2100 98
12	1	500036	1 1/2"X 1"NPT REDU BUSH, POLY	35	1	701132	CHEM IND LATCH WLD, 2100 98
13	4	500053	2"NPT-90 ST EL, POLY	36	1	701135	CHEM IND LATCH MT WLD,2100 98
14	2	500024	1"NPT-90-1"HOSE BARB, POLY	37	1	701139	CHEM IND SUPP BRACE, 2100 98
15	1	500055	2" NPT PIPE TEE, POLY	38	2	701140	CHEM IND SUPPER TUBE, 2100 98
16	1	500056	2" NPT CLOSE HEX NIPPLE, POLY	39	4	900064	5/16UNC X 3/4 HEX BOLT
17	1	500057	2"NPT X 1 1/2 H BARB, POLY	40	2	900065	5/16UNC X 1" HEX BOLT
18	2	500058	2"NPT X 2" H BARB, POLY	41	2	900128	3/8UNC X 3/4 HEX BOLT
19	1	500066	1 1/2NPT-90-1 1/2 H BARB POLY	42	3	900272	1/2UNC X 3 1/2 HEX BOLT
20	1	500086	1 1/2" NPT COUPLING, POLY	43	6	910002	5/16UNC HEX NUT
21	1	500063	1"NPT PIPE PLUG, POLY	44	2	914002	5/16UNC HEX STOVER NUT
22	4	520138	1.38/1.56 T-BOLT HOSE CLAMP	45	3	914008	1/2UNC HEX STOVER NUT
23	2	520133	1.81/2.06 T-BOLT HOSE CLAMP SS	46	2	914004	3/8UNC HEX STOVER NUT

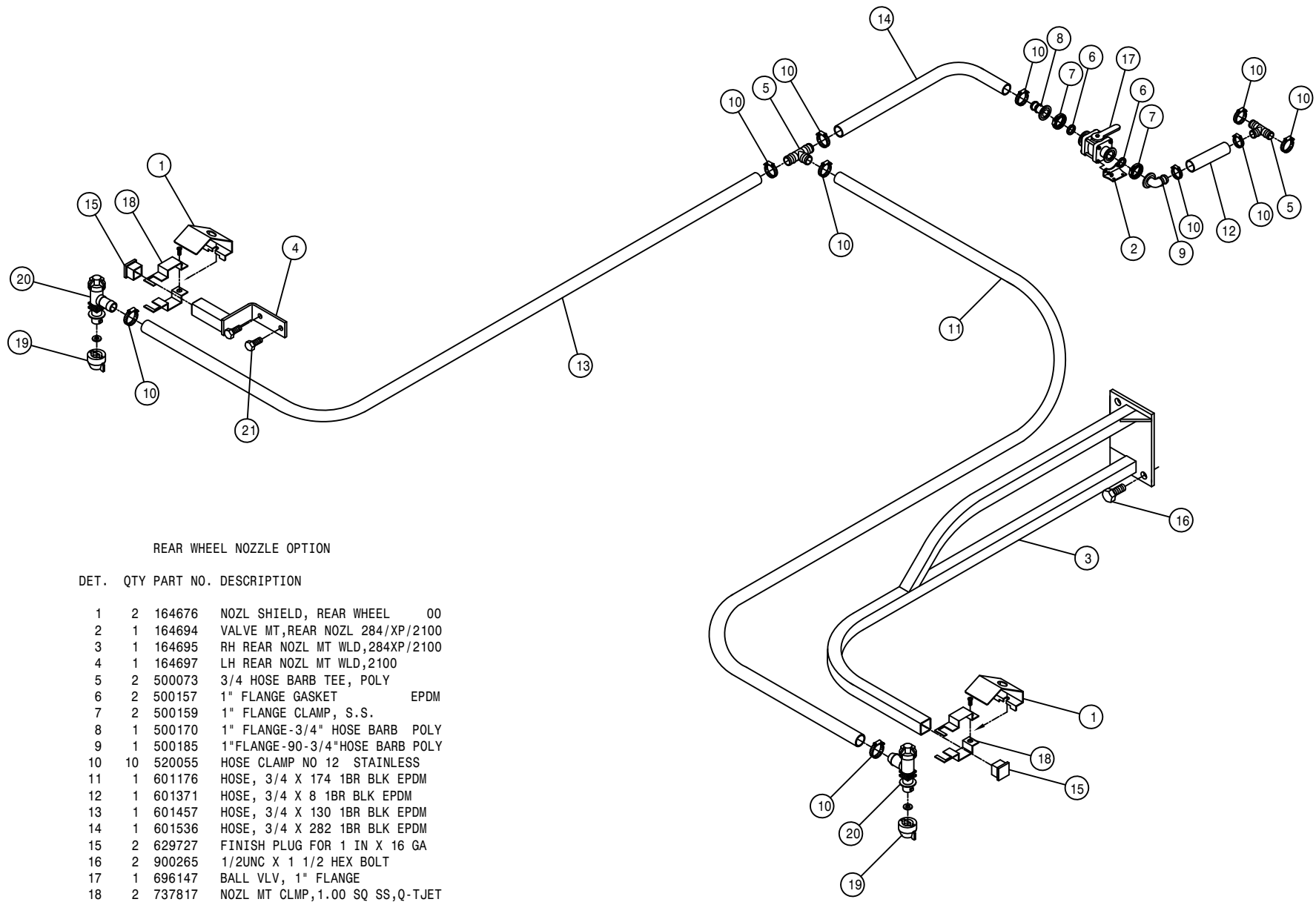

REAR WHEEL NOZZLE OPTION

DET.	QTY	PART NO.	DESCRIPTION
	1	2	164676 NOZL SHIELD, REAR WHEEL 00
	2	1	164694 VALVE MT, REAR NOZL 284/XP/2100
	3	1	164695 RH REAR NOZL MT WLD, 284XP/2100
	4	1	164697 LH REAR NOZL MT WLD, 2100
	5	2	500073 3/4 HOSE BARB TEE, POLY
	6	2	500157 1" FLANGE GASKET EPDM
	7	2	500159 1" FLANGE CLAMP, S.S.
	8	1	500170 1" FLANGE-3/4" HOSE BARB POLY
	9	1	500185 1" FLANGE-90-3/4" HOSE BARB POLY
	10	10	520055 HOSE CLAMP NO 12 STAINLESS
	11	1	601176 HOSE, 3/4 X 174 1BR BLK EPDM
	12	1	601371 HOSE, 3/4 X 8 1BR BLK EPDM
	13	1	601457 HOSE, 3/4 X 130 1BR BLK EPDM
	14	1	601536 HOSE, 3/4 X 282 1BR BLK EPDM
	15	2	629727 FINISH PLUG FOR 1 IN X 16 GA
	16	2	900265 1/2UNC X 1 1/2 HEX BOLT
	17	1	696147 BALL VLV, 1" FLANGE
	18	2	737817 NOZL MT CLMP, 1.00 SQ SS, Q-TJET
	19	2	737822 CAP SET, YELLOW QUICK TEEJET
	20	2	737829 QUICK TJET EL BODY DIAPH .75
	21	2	900066 5/16UNC X 1 1/4 HEX BOLT

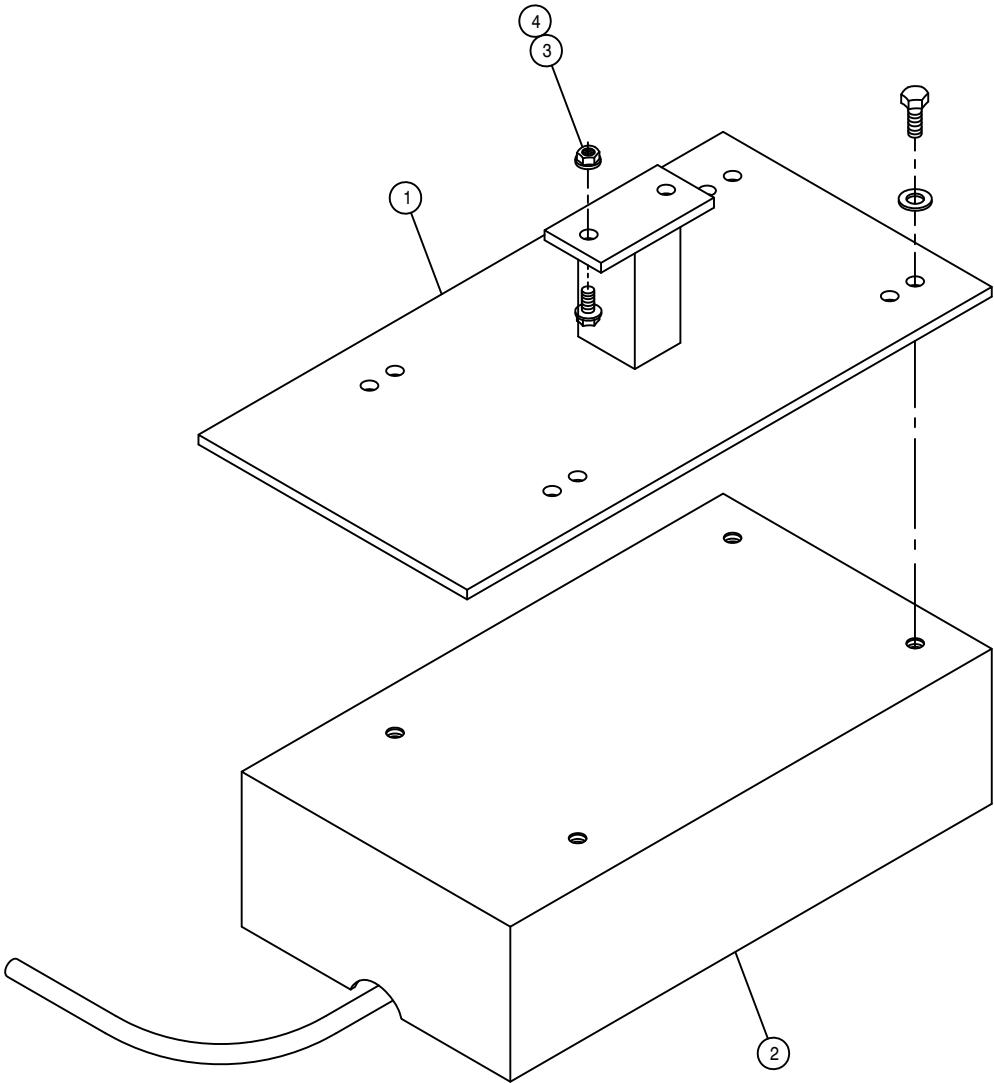

RADAR OPTION

DET.	QTY	PART NO.	DESCRIPTION
1	1	690462	RADAR MTG BRKT WLD, INJ SYS
2	1	690599	RAVEN RADAR UNIT W/CABLE
3	2	470118	1/4UNC X 3/4 FLANGE HEX BOLT
4	2	470121	1/4UNC HEX FLANGE LOCK NUT

INJECTION SYSTEM PLATFORM OPTION

DET.	QTY	PART NO.	DESCRIPTION
1	1	690637	INJ SYS PLATFORM WLD, 2100 99
2	2	690641	INJ SYS PLATFORM MT WLD, 2100
3	4	914008	1/2UNC HEX STOVER NUT
4	4	900272	1/2UNC X 3 1/2 HEX BOLT

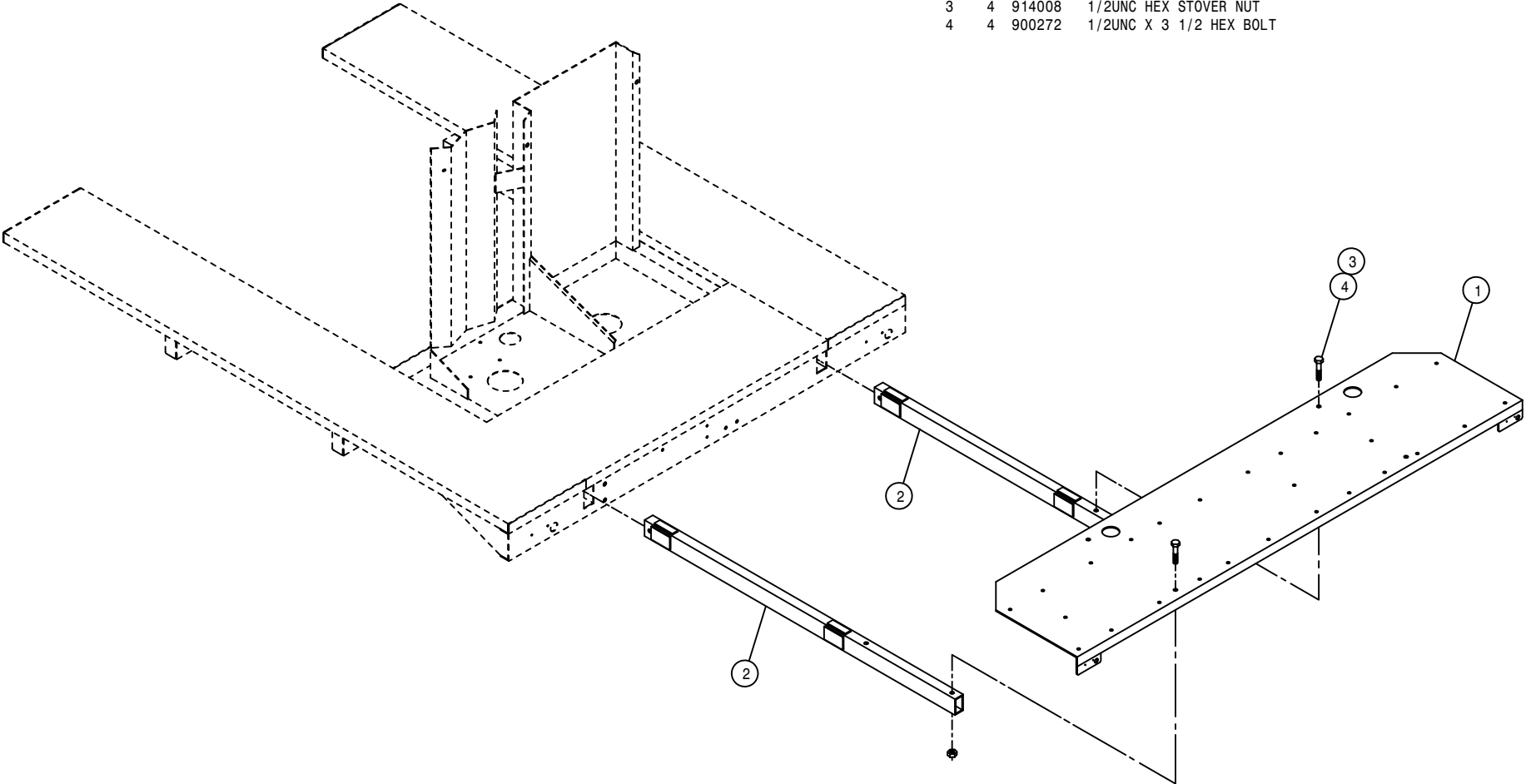

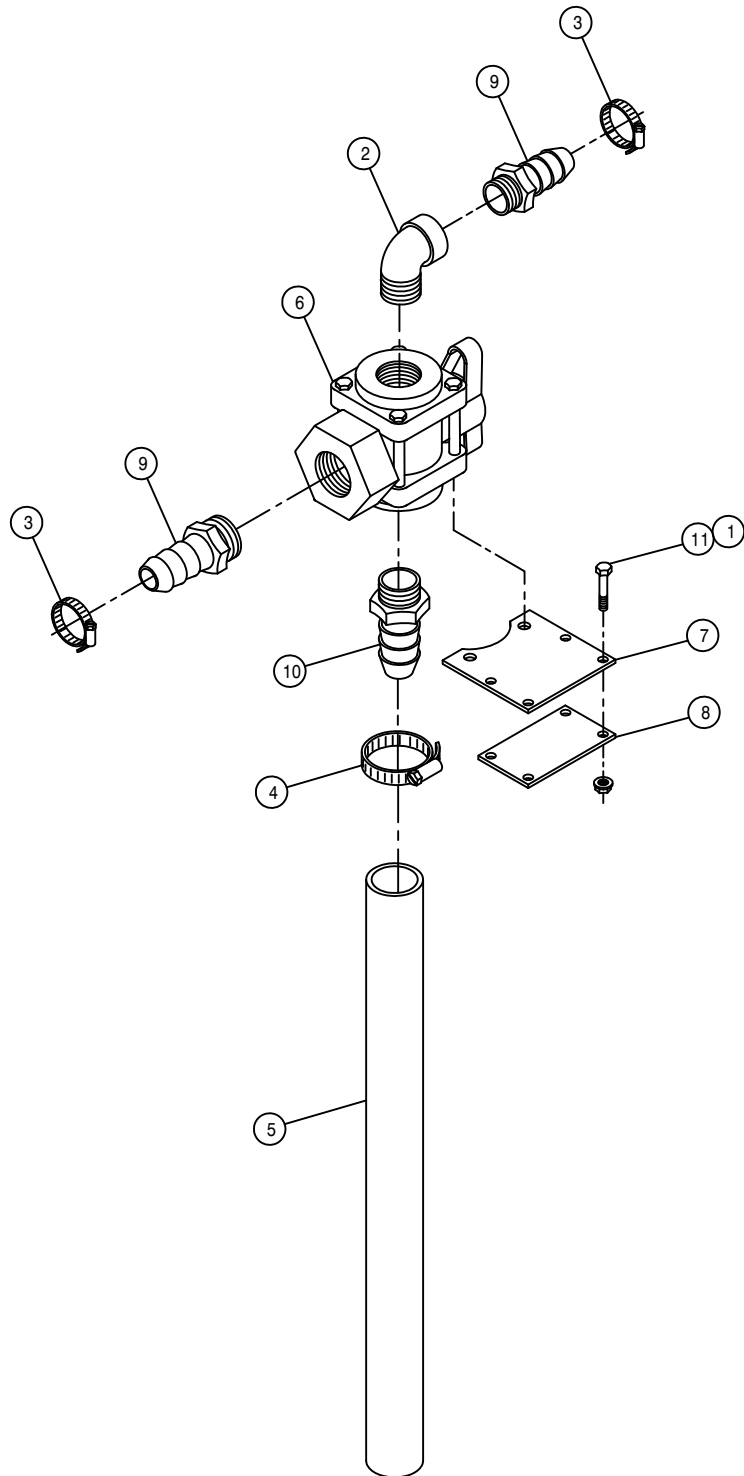

60'-80' FOAMER DIVERT VALVE OPTION

DET. QTY PART NO. DESCRIPTION

1	8	470121	1/4UNC HEX FLANGE LOCK NUT
2	2	500014	1"NPT-90 ST EL, POLY
3	4	520055	HOSE CLAMP NO 12 STAINLESS
4	2	520085	HOSE CLAMP NO 24 STAINLESS
5	2	601367	HOSE, 1 1/4 X 24 2BR BLK EPDM
6	2	696133	BALL VLV, 1.00NP 3WAY-BOTT POLY
7	2	701152	FOAMER DIVERTER VALVE MT BRKT
8	2	701153	FOAMER DIVERTER VLV BRKT KEEPR
9	4	714331	1 NPT X 3/4 HOSE BARB
10	2	714561	1.00NPT-1.25 HOSE BARB
11	8	900007	1/4UNC X 2" HEX BOLT

NOTE: QUANTITY LISTED IS FOR ONE MACHINE.

This Page Intentionally Blank

# NOTICE

---

The following page contains decals for the model 2100.

These decals can be obtained from Hagie Mfg. Co. and should be used whenever your machine is repainted or when the decals become worn, weathered, or faded.

Special attention should be paid to decals involving personal safety. They have been attached for your protection.

**KEEP THEM IN PLACE.**

Contact: Hagie Manufacturing Co.  
Box 273  
Clarion, Iowa 50525



2100 DECALS

<u>QTY.</u>	<u>PART NO.</u>	<u>DESCRIPTION</u>	<u>LOCATION</u>
1	650320	EMERGENCY EXIT DECAL	ON THE LOWER LEFT ON REAR WINDOW
1	650326	HAGIE DECAL	ON FRONT MAINFRAME SHIELD
1	650336	FOLD BOOM WARNING DECAL	ON RH SIDE WINDOW
1	650337	ELECTROCUTION HAZARD DECAL	ON RH SIDE WINDOW
1	650339	HYDRAULIC OIL INJ. DECAL	ON STEERING POST
1	650340	PARK BRAKE DECAL	NEAR PARK SWITCH
1	650341	DECAL SET, HAGIE 2100 STRIPE	ON EACH ENGINE HOOD
1	650343	HYDROSTATIC CONTROL DECAL	ON CONSOLE
1	650344	SWITCH PANEL DECAL	ON SWITCH PANEL COVER
1	650345	BOOM CONTROL PANEL DECAL	ON SWITCH PANEL COVER
1	650346	TREAD ADJUST DECAL	ON CONSOLE
1	650347	NOTICE-R134A CHARGE DECAL	ON ENGINE NEAR A/C COMPRESSOR
1	650348	NOTICE-DRAIN AIR TANK DECAL	ON AIR TANK
1	650349	LIGHT SWITCH PANEL DECAL	ON SWITCH PANEL IN HEADLINER
1	650350	CAUTION, BOOSTER TERMINAL DECAL	ON LOWER BACK SHEET METAL
1	650351	AGITATION VFC DECAL	ON LOWER BACK SHEET METAL
2	650352	RH TREAD ADJ INDICATOR DECAL	1-ON RH FRONT INDICATOR MOUNT 1-ON LH REAR INDICATOR MOUNT
2	650353	LH TREAD ADJ INDICATOR DECAL	1-ON LH FRONT INDICATOR MOUNT 1-ON RH REAR INDICATOR MOUNT
1	650354	FUSE BOX DECAL	ON FUSE BOX COVER
1	650822	SOLUTION PUMP DECAL	ON FRONT MAINFRAME SHIELD
1	650831	EMERGENCY STOP DECAL	ON STEERING POST
1	650847	NO PASSENGER DECAL	ON LH REAR ON CAB
2	650848	SLIP OR FALL DECAL	ON BACK OF FUEL TANKS
2	650849	ENGINE FUEL DECAL	NEAR EACH FUEL TANK NECK
2	650850	CHEMICAL DECAL	ON TANK BAND TIE
2	650851	SHIELDS DECAL	ON LOWER REAR OF MAINFRAME
1	650852	READ MANUAL DECAL	ON LEFT CONSOLE TOP
1	650954	DIESEL DECAL	NEAR EACH FUEL NECK
1	650981	COOLING SYSTEM DECAL	NEAR RADIATOR CAP
1	650982	ELECTRICAL DECAL	ON ENGINE HOOD ABOVE BATTERY
4	650985	WHEEL BOLT TORQUE DECAL	ON EACH WHEEL RIM

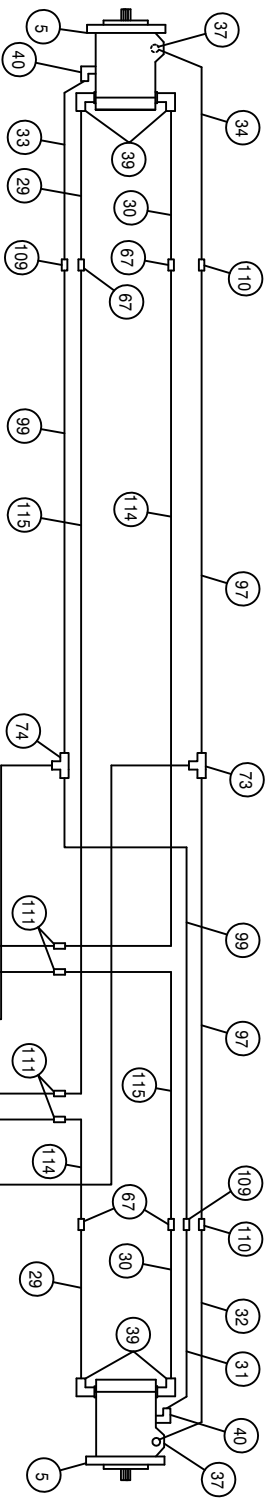

\*NOTE:  
 REFER TO DETAIL 57 TO CHECK AUX. SYSTEM - 1850 PSI  
 REFER TO DETAIL 50 TO CHECK LIMIT SETTING - 4500 PSI  
 REFER TO DETAIL 60 TO CHECK CHARGE PRESSURE - 380 PSI

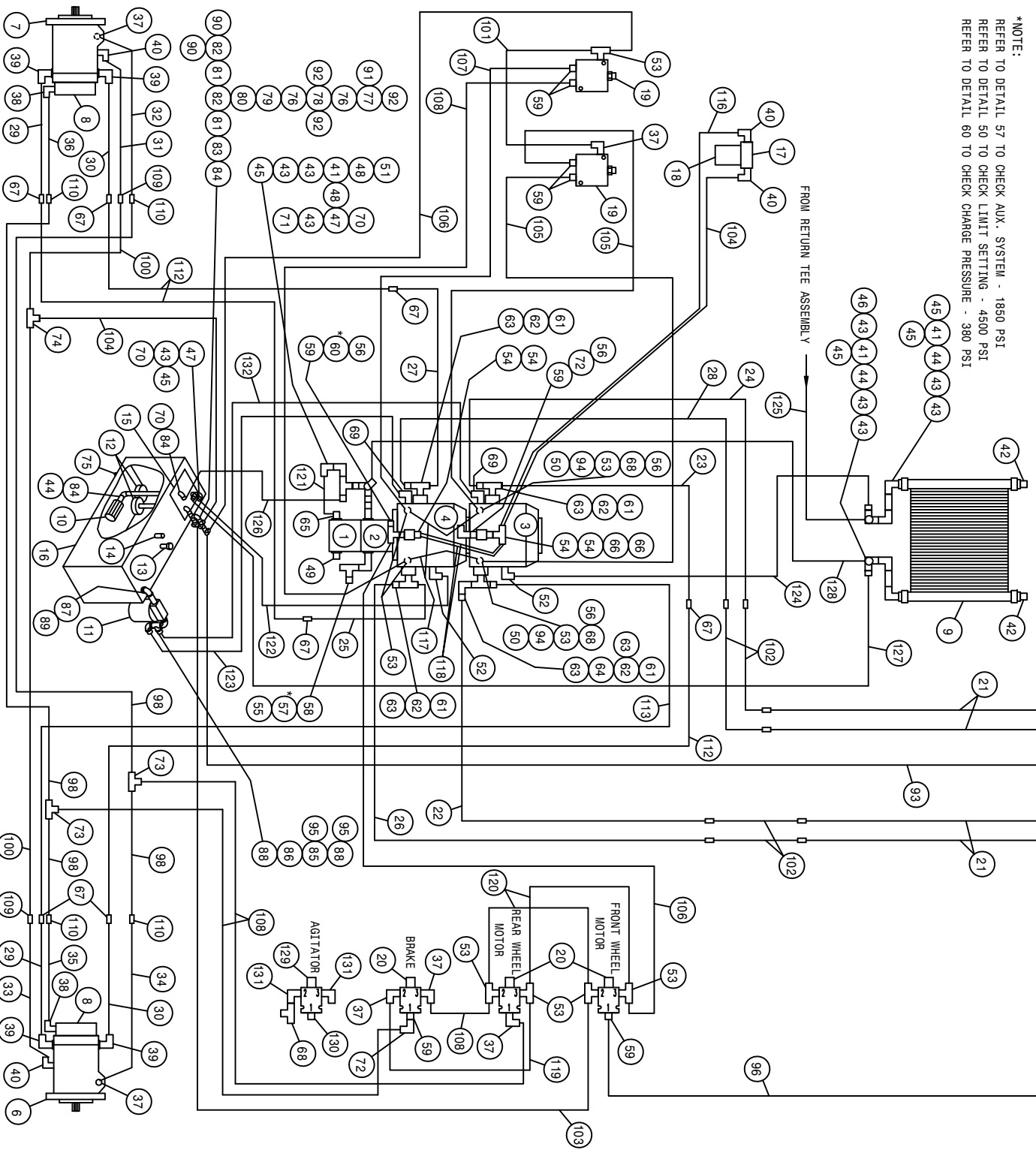

2100 HYDRAULIC SCHEMATIC 2001  
REFERENCE DRAWING NO. 49862351

DET.	QTY	PART NO.	DESCRIPTION	DET.	QTY	PART NO.	DESCRIPTION
1	1	606929	SUND GEAR PUMP .66CI, SPLINED	67	11	618577	1 5/16MJIC UNION
2	1	606932	SUND GEAR PUMP-1.60CI,SPLINED	68	3	618486	9/16FJIC SW RUN TEE-9/16MJIC
3	1	606944	SUND 75CC PUMP,C/C-MT	69	2	618564	1IN HOSE BARB-90-1 5/16MOR
4	1	606947	SUND 75CC PUMP,C/B-MT	70	3	714560	INPT X 1 HOSE BARB
5	2	610637	SUND HYD MOTOR, M46-.4019	71	1	716000	3/4 HOSE BARB-90-1MNPT
6	1	610640	SUND HYD MOTOR, M46-.4144	72	2	618618	9/16MJIC-90-9/16FJIC SWIV LBO
7	1	610643	SUND HYD MOTOR, M46-4199 W/SEN	73	3	618019	9/16MJIC UNION TEE
8	2	828093	MICO HYD BRAKE	74	2	618311	3/4MJIC UNION TEE
9	1	618606	OIL COOLER, BLISSFIELD 65027	75	1	501102	1/4 PIPE PLUG
10	1	605600	MICHIGAN RESERVOIR FILTER	76	2	503600	CLOSE NIPPLE .50NPT
11	1	605601	GRESSEN FILTER 10 MICRON 40GPM	77	1	503820	BLK PIPE TEE .50NPT
12	2	605603	LINE SLUMP DIFUSER	78	1	503824	BLK PIPE CROSS .50NPT
13	2	611052	FILTER BREATHER 3/4INPT	79	1	504210	RED BUSH 3/4 NPT X 1/2 NPT
14	1	614453	DIPSTICK, 8IN	80	1	504610	BLK PIPE ST EL 90DEG .75NPT
15	1	760090	RECEIVER PLT WLD 8240	81	2	504702	CLOSE NIPPLE .75NPT
16	1	760205	HYD TANK WELD, 2100	82	2	504955	BLK PIPE TEE .75NPT
17	1	605608	HYD FILTER HEAD, DONALDSON	83	1	505213	RED BUSH 1 X 3/4 BLK MAL
18	1	605609	HYD FILTER ELEMENT, DONALDSON	84	3	505300	BLK PIPE EL 90DEG 1.00NPT
19	2	610580	REMOTE FLUSHING VALVE, SUND	85	1	506105	BLK PIPE TEE 1.25NPT
20	3	610318	HYD SOLE VLV,2P-3W,9/16FOR,12V	86	1	506200	CLOSE NIPPLE 1.25NPT
21	4	615724	FRT MAIN HYD TUBE ASSY,2100 98	87	1	506303	BLK PIPE ST EL 90DEG 1.25NPT
22	1	615717	RH FRT PUMP LMR TUBEASSY210098	88	2	506410	BLK PIPE NIPPLE 1.25NPT
23	1	615718	LH FRT PUMP UPR TUBEASSY210098	89	1	506604	BLK PIPE NIPPLE 1.25NPT-4.00
24	1	615719	LH FRT PUMP LMR TUBEASSY210098	90	2	610305	3/4MJIC-90-3/4MNPT LBO
25	1	615720	RH REAR PUMP UPR TUBE ASSY	91	1	618018	9/16MJIC-1/2MNPT ADPTR
26	1	615721	RH REAR PUMP LMR TUBE ASSY	92	3	618107	9/16MJIC-90-1/2MNPT LBO
27	1	615722	LH REAR PUMP UPR TUBE ASSY	93	1	615737	08C2AT-08FJX-08FJX90-198
28	1	615723	LH REAR PUMP LMR TUBE ASSY	94	2	618291	9/16FJX-1/4FNPT ADPTR
29	4	615708	LMR HYD TUBE ASSY,LEG 2100	95	2	715664	1 1/4 NPT X 1 HOSE BARB
30	4	615709	UPR HYD TUBE ASSY,LEG 2100	96	1	611246	04C1T-06FJX-06FJX-174
31	2	615710	RF/LR HYD DRN TUBE ASSY2100 98	97	2	614152	04C1T-06FJX-06FJX-114
32	2	615712	RF/LR HYD CTRL TUBE ASSY210098	98	4	614157	04C1T-06FJX-06FJX-101
33	2	615711	LF/RR HYD DRN TUBE ASSY2100 98	99	2	614546	08C1T-08FJX-08FJX-115
34	2	615713	LF/RR HYD CTRL TUBE ASSY210098	100	2	614688	08C1T-08FJX-08FJX-108
35	1	615714	RH HYD BRAKE TUBE ASSY,2100 98	101	1	614713	04C1T-06FJX-06FJX-24
36	1	615715	LH HYD BRAKE TUBE ASSY,2100 98	102	4	614734	12TWM-12MJ-12MJ-16
37	8	618119	9/16MJIC-90-9/16MOR LBO	103	1	616026	04C1T-06FJX-06FJX-37
38	2	618114	9/16MJIC-90-7/16MOR LBO	104	2	616034	08C1T-08FJX-08FJX-17
39	8	618178	1 5/16MJIC-90-1 5/16MOR LBO	105	2	616037	04C1T-06FJX-06FJX-29
40	6	618474	3/4MJIC-90-1 1/16MOR LBO	106	2	616039	04C1T-06FJX-06FJX-19
41	3	505098	SIDE OUTLET EL 90DEG 1.00NPT	107	1	616043	04C1T-06FJX-06FJX-23
42	2	505102	PIPE PLUG 1.00NPT SQ HD	108	4	616049	04C1T-06FJX-06FJX-26
43	9	505200	BLK PIPE ST EL 90DEG 1.00NPT	109	4	618314	3/4MJIC UNION
44	3	505203	BLK PIPE NIPPLE 1.00NPT-4.00	110	6	619010	9/16MJIC UNION
45	5	714531	1 NPT X 3/4 HOSE BARB	111	4	618177	1 1/16MJIC UNION
46	1	714560	INPT X 1 HOSE BARB	112	3	614735	12TWM-16FJX-16FJX-75
47	2	505101	BLK PIPE TEE 1.00NPT	113	1	614736	12TWM-12FJX90-16FJX-75
48	2	505105	INMPT HEX PIPE NIPPLE STL	114	2	614737	12TWM-12FJX90-16FJX-99
49	1	611126	7/8MJIC-7/8MOR ADPTR	115	2	614738	12TWM-12FJX90-16FJX-114
50	2	614740	RESTRICTOR FTG ASSY, .050	116	1	615626	08C1T-08FJX-08FJX-15
51	1	618090	1 5/16MOR-1FNPT ADPTR	117	2	615734	04C2AT-06FJX-06FJX-11
52	2	618118	3/4 HOSE BARB-90-1 1/16MOR	118	2	614739	08C1T-08FJX-08FJX90-16
53	9	618629	9/16MOR BRANCH TEE-9/16MJIC	119	1	614712	04C1T-06FJX-06FJX-20
54	4	618327	3/4MJIC-7/8MOR ADPTR	120	2	615725	04C1T-06FJX-06FJX-10
55	1	618328	7/8FJIC CAP NUT	121	1	601383	HOSE, 3/4 X 8 1FBR-1SPI
56	4	618531	9/16FJIC CAP NUT	122	1	601384	HOSE, 3/4 X 40 1FBR-1SPI
57	1	618333	7/8FJIC SW RUN TEE-7/8MJIC	123	1	601543	HOSE, 1 X 36 1FBR-1SPI
58	1	618535	7/8MJIC-90-1 1/16MOR LBO	124	1	601407	HOSE, 3/4 X 62 1FBR-1SPI
59	8	618126	9/16MJIC-9/16MOR ADPTR	125	1	601406	HOSE, 3/4 X 38 1FBR-1SPI
60	1	618514	9/16FJ SW BRANCH TEE-9/16MJ	126	1	601544	HOSE, 1 X 42 1FBR-1SPI
61	4	618598	1" 4-BOLT FLG X 1 5/16 FOR	127	1	601411	HOSE, 1 X 100 1FBR-1SPI
62	4	618599	1 5/16MOR BRANCH TEE-1 5/16MJ	128	1	601408	HOSE, 3/4 X 77 1FBR-1SPI
63	5	618541	1 5/16FJIC-1 1/16MJIC ADPTR	129	1	610674	HYD SOLE VLV,2P3W,3/4FOR,12V
64	1	618640	1 5/16MJ-90-1 5/16FJ SWIV LBO	130	1	618109	9/16MJIC-3/4MOR ADPTR
65	1	618075	3/4 HOSE BARB-1 1/16MOR	131	2	618115	9/16MJIC-90-3/4MOR LBO
66	2	618643	3/4FJ SW BRANCH TEE-3/4MJ	132	1	601376	HOSE, 1 X 29 1FBR-1SPI

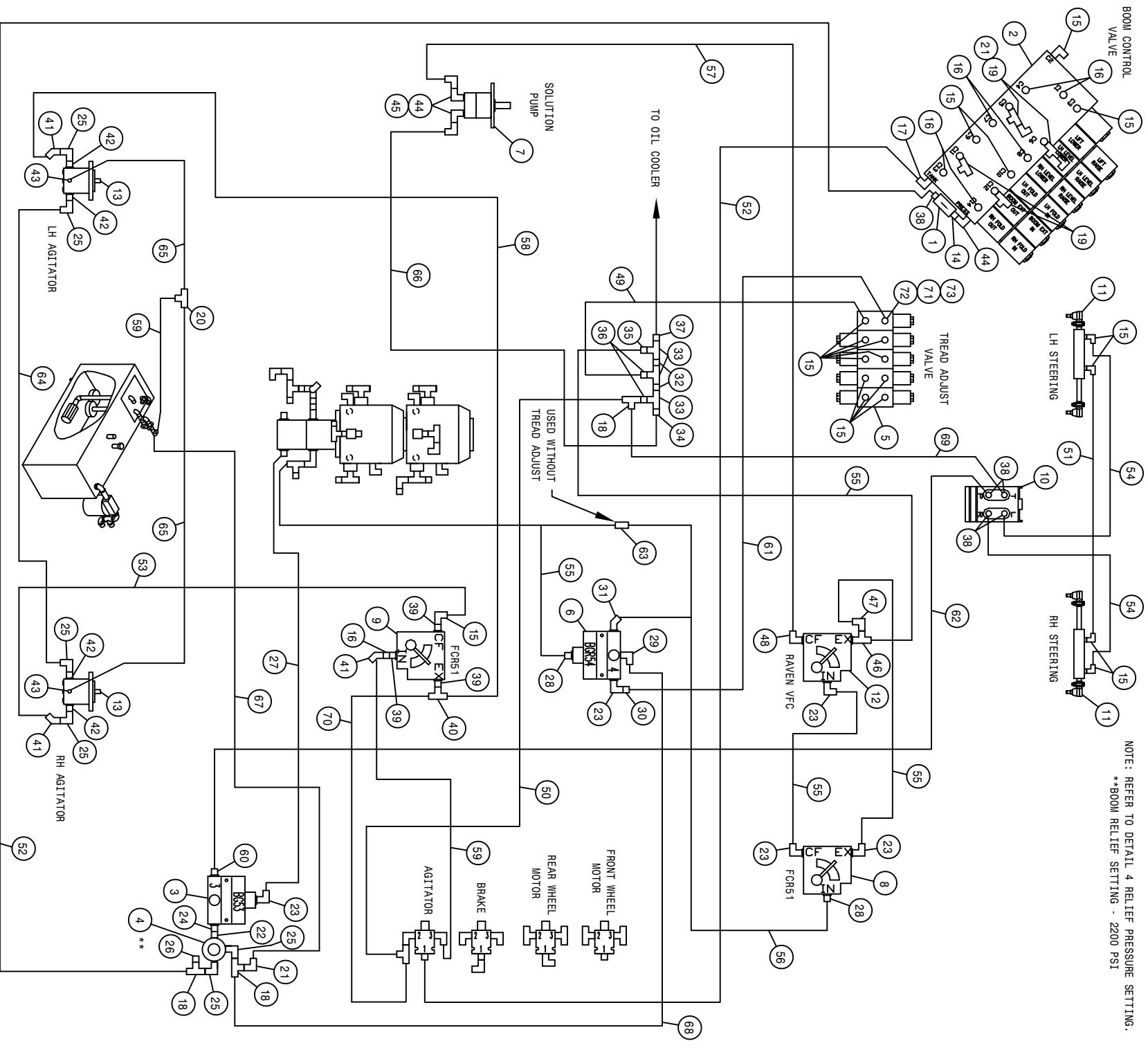

NOTE: REFER TO DETAIL 4 RELIEF PRESSURE SETTING.  
 \*\*BOOM RELIEF SETTING - 2200 PSI

2100 HYDRAULIC SCHEMATIC 2000  
REFERENCE DRAWING NO. 498623S2

DET.	QTY	PART NO.	DESCRIPTION	DET.	QTY	PART NO.	DESCRIPTION
1	1	605610	HYD FILTER, INLINE 90M 3/4FOR	38	618109	9/16MJIC-3/4MOR ADPTR	
2	1	606065	BOOM VALVE	39	618172	7/8MOR-9/16FOR ADPTR	
3	1	610307	FLO DIV BGS3 3GPM PRI 7/8FOR	40	618629	9/16MOR BRANCH TEE-9/16MJIC	
4	1	607512	RELIEF VALVE, RL50, 1850 PSI	41	618634	9/16MJIC-45-9/16FJIC SWIV LBO	
5	1	610656	5 SECT, 4 FUNCTN HYD VLV, Eaton	42	618092	1 1/16MOR-1/2FNPT ADPTR	
6	1	607528	FLO DIV BGR54 4GPM PRI 7/8FOR	43	618338	9/16MJIC-45-1/4MNPT LBO	
7	1	690573	HYD MOTOR, FLOMAX HI-SPEED	44	618241	3/4MJIC-90-3/4MOR LBO	
8	1	606818	FLO CONT FCR51 0-16GPM 7/8FOR	45	618609	3/4MJIC-90-3/4FJIC SWIV LBO	
9	1	606827	FLO CONT FCS1 0-3 VARI 7/8FOR	46	618130	7/8MOR RUN TEE-7/8MJIC	
10	1	749318	STRG MTR, 7.3CID, NON-LOAD 1031	47	618301	7/8MJIC-90-7/8FJIC SWIV LBO	
11	2	620835	STRG CYL ASSY, 2100	48	618183	3/4MJIC-90-7/8MOR LBO	
12	1	690621	VALVE HYD CTRL, 16GPM RAVEN	49	616037	04C1T-06FJX-06FJX-29	
13	2	610510	CESSNA GEAR MOTOR 1.48CI	50	614693	06C1T-06FJX-06FJX-168	
14	1	618669	3/4FJIC SWIV-3/4MOR ADPTR	51	611246	04C1T-06FJX-06FJX-174	
15	18	618119	9/16MJIC-90-9/16MOR LBO	52	615735	06C1T-06FJX-06FJX-300	
16	7	618126	9/16MJIC-9/16MOR ADPTR	53	614549	06C1T-06FJX-06FJX-140	
17	1	618115	9/16MJIC-90-3/4MOR LBO	54	614639	04C1T-06FJX-06FJX-126	
18	3	618486	9/16FJIC SW RUN TEE-9/16MJIC	55	614732	10C2AT-10FJX-10FJX-29	
19	4	618444	9/16MOR RUN TEE-9/16MJIC	56	614733	10C2AT-10FJX-10FJX-57	
20	1	618019	9/16MJIC UNION TEE	57	616057	08C1T-08FJX-08FJX-88	
21	3	618618	9/16MJIC-90-9/16FJIC SWIV LBO	58	615348	06C1T-06FJX-06FJX-127	
22	1	500000	1/2MNPT HEX PIPE NIPPLE STL	59	615401	06C1T-06FJX-06FJX-22	
23	5	611128	7/8MJIC-90-7/8MOR LBO	60	618310	9/16MJIC-7/8MOR ADPTR	
24	1	618072	7/8MOR-1/2FNPT ADPTR	61	615728	04C1T-06FJX-06FJX-80	
25	6	618107	9/16MJIC-90-1/2MNPT LBO	62	615730	04C1T-06FJX-06FJX-150	
26	1	618531	9/16FJIC CAP NUT	63	618456	7/8MJIC UNION	
27	1	614744	10C2AT-10FJX-10FJX-18	64	615732	06C1T-06FJX-06FJX-194	
28	2	611126	7/8MJIC-7/8MOR ADPTR	65	615733	06C1T-06FJX-06FJX-101	
29	1	618015	9/16MJIC-90-3/8MNPT LBO	66	615736	08C2AT-08FJX-08FJX-46	
30	1	618557	7/8FJIC-9/16MJIC ADPTR	67	615442	04C1T-06FJX-06FJX-55	
31	1	618644	7/8MJIC-45-7/8MOR LBO	68	616028	04C1T-06FJX-06FJX-47	
32	2	504702	CLOSE NIPPLE .75NPT	69	616049	04C1T-06FJX-06FJX-26	
33	3	504955	BLK PIPE TEE .75NPT	70	615621	06C1T-06FJX-06FJX-24	
34	1	610300	3/4MJIC-3/4MNPT ADPTR	71	610447	HYD FILTER, INLINE 1/4FNPT	
35	1	618059	7/8MJIC-3/4MNPT ADPTR	72	618562	9/16MOR-90-1/4MNPT LBO	
36	2	618642	9/16MJIC-3/4MNPT ADPTR	73	611122	9/16MJIC-90-1/4MNPT LBO	
37	1	713220	HOSE BARB 3/4 NPT X 3/4				

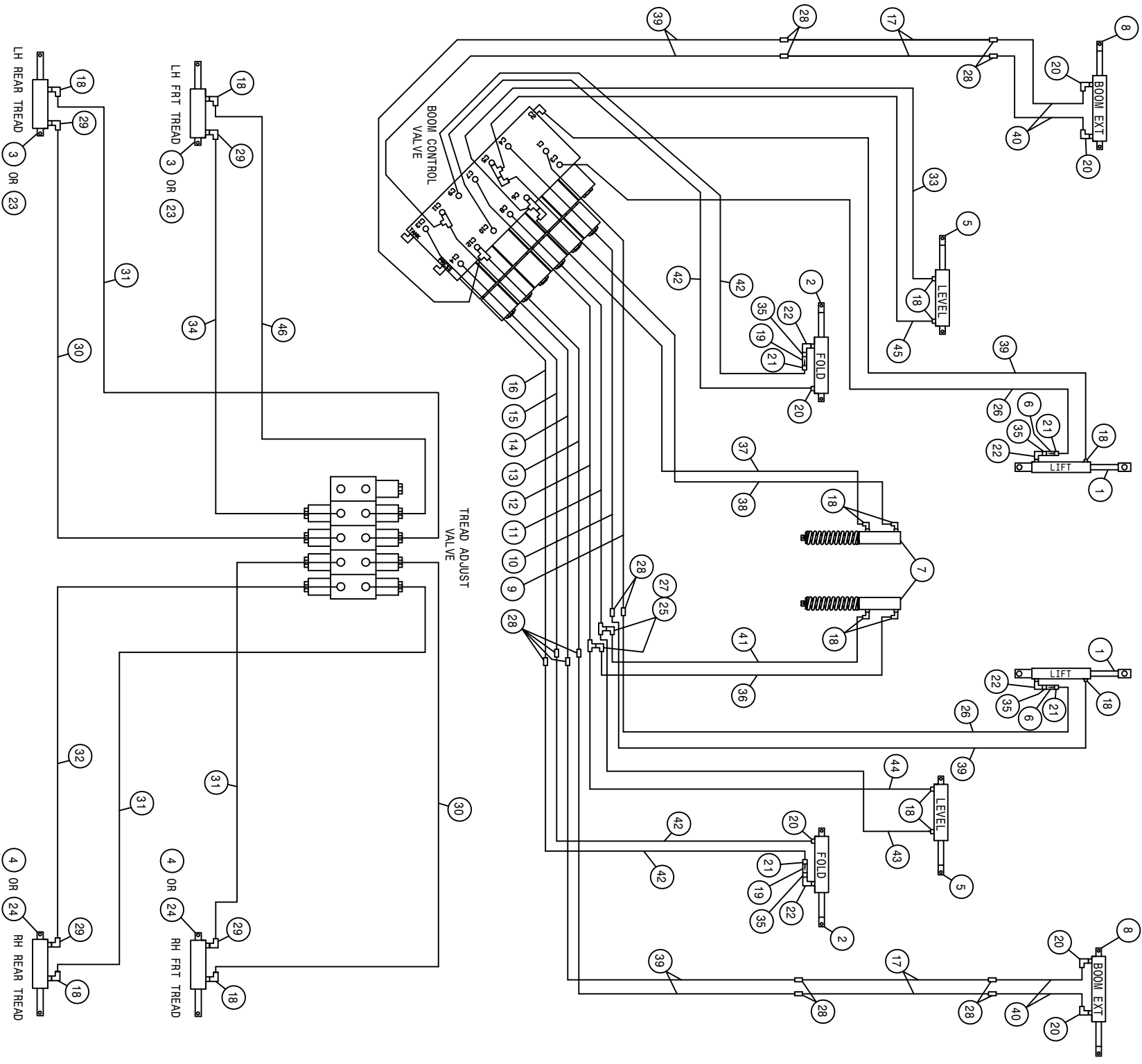

2100 HYDRAULIC SCHEMATIC 2001  
REFERENCE DRAWING NO. 498623S3

DET.	QTY	PART NO.	DESCRIPTION	DET.	QTY	PART NO.	DESCRIPTION
1	2	620840	TRANSOM LIFT CYL ASSY	24	2	620885	LEG CYL ASSY, 154RH TRD ADJ2100
2	2	620845	BOOM HINGE FOLD CYL ASSY	25	2	618618	9/16MJIC-90-9/16FJIC SWIV LBO
3	2	620875	LEG CYL, TRD ADJ, RH 284-LH 2100	26	2	615616	04C1T-06FJX-06FJX-65
4	2	620880	LEG CYL, TRD ADJ, LH 284-RH 2100	27	2	618019	9/16MJIC UNION TEE
5	2	620850	BOOM LEVEL CYL ASSY	28	14	619010	9/16MJIC UNION
6	2	610675	RESTRICTOR, .042 1-WAY, 1/2FNPT	29	4	614747	.025 ELBOW ASSY, 9/16MOR 90D
7	2	620855	ACCUMULATOR CYL ASSY	30	2	611204	04C1T-06FJX-06FJX-78
8	2	620860	BOOM CNTR SECT FOLD CYL ASSY	31	3	614077	04C1T-06FJX-06FJX-88
9	1	615761	LIFT RAISE HYD TUBE ASSY	32	1	615726	04C1T-06FJX-06FJX-73
10	1	615762	LIFT LOWER HYD TUBE ASSY	33	1	615314	04C1T-06FJX-06FJX-50
11	1	615763	LEVEL RAISE HYD TUBE ASSY	34	1	615729	04C1T-06FJX-06FJX-84
12	1	615764	LEVEL LOWER HYD TUBE ASSY	35	4	503010	RED BUSH 1/2MNPT-3/8FNPT, STEEL
13	1	615766	BOOM EXTN RAISE HYD TUBE ASSY	36	1	614712	04C1T-06FJX-06FJX-20
14	1	615767	BOOM EXTN LOWER HYD TUBE ASSY	37	1	614713	04C1T-06FJX-06FJX-24
15	1	615768	RH FOLD RAISE HYD TUBE ASSY	38	1	616037	04C1T-06FJX-06FJX-29
16	1	615769	RH FOLD LOWER HYD TUBE ASSY	39	6	616040	04C1T-06FJX-06FJX-67
17	4	615684	HYD TUBE ASSY, BOOM EXT FOLD96	40	4	616043	04C1T-06FJX-06FJX-23
18	14	618119	9/16MJIC-90-9/16MOR LBO	41	1	616049	04C1T-06FJX-06FJX-26
19	2	610450	RESTRICTOR .025 1-WAY, 1/2FNPT	42	4	615442	04C1T-06FJX-06FJX-55
20	6	614750	.042 ELBOW ASSY, 9/16MOR 90D	43	1	616028	04C1T-06FJX-06FJX-47
21	4	618018	9/16MJIC-1/2MNPT ADPTR	44	1	614714	04C1T-06FJX-06FJX-34
22	4	618651	9/16MOR-90-3/8MNPT LBO	45	1	616026	04C1T-06FJX-06FJX-37
23	2	620890	LEG CYL ASSY, 154LH TRD ADJ2100	46	1	615727	04C1T-06FJX-06FJX-75

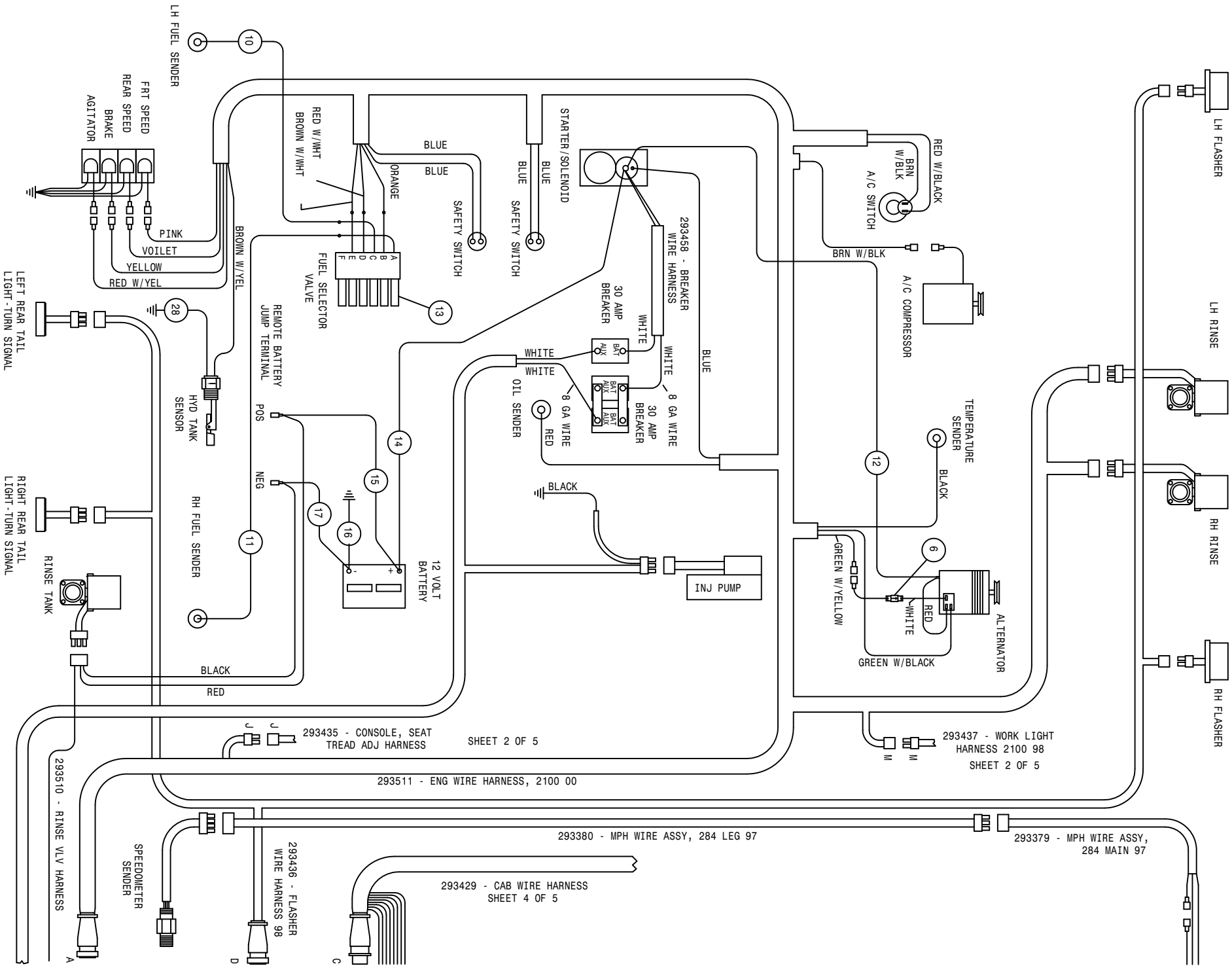

SHEET 2 OF 5



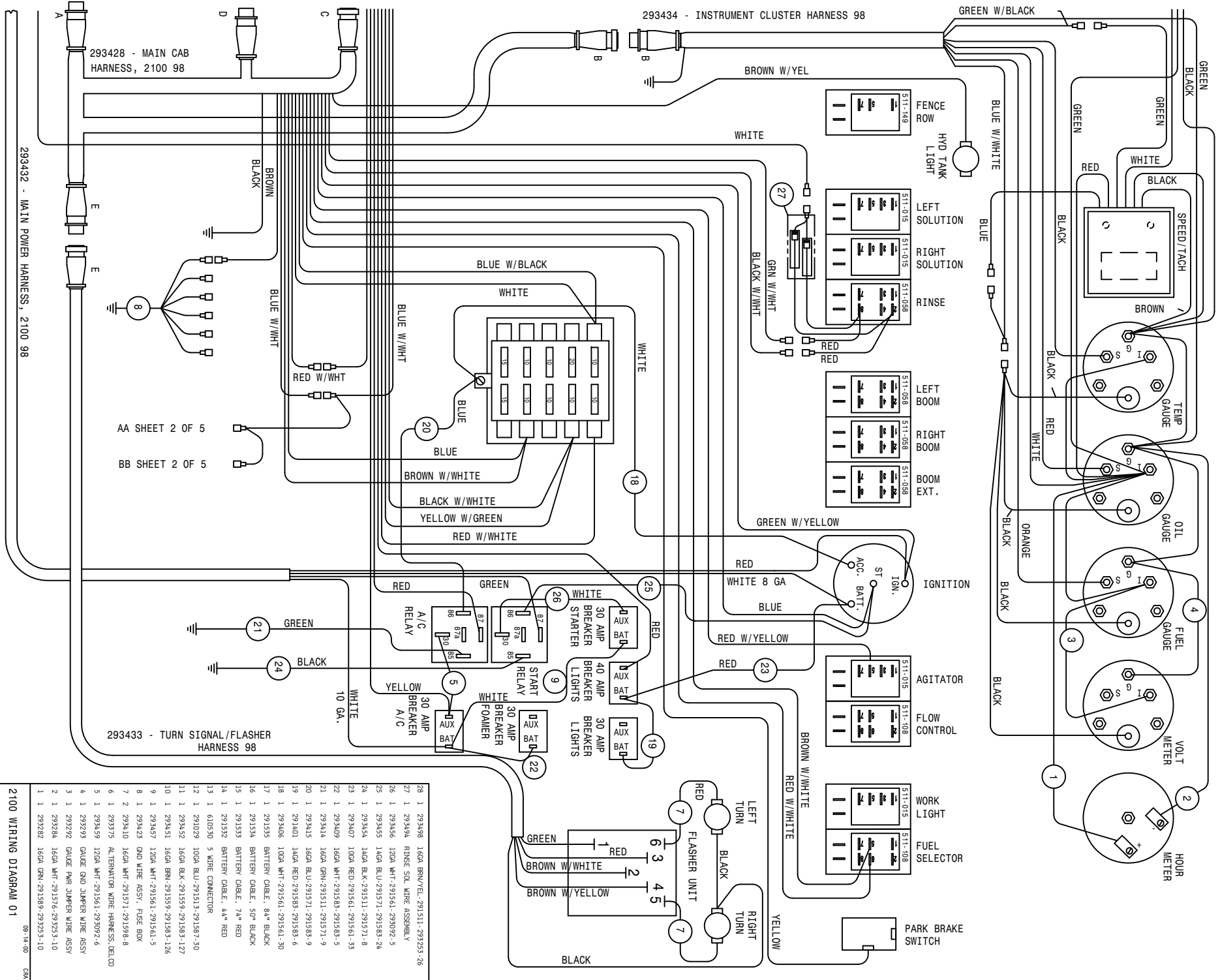

28	1	293498	16GA BRN/YEL-291511-293253-26
27	1	293494	RINSE SOL. WIRE ASSEMBLY X
26	1	293456	12GA WHT-291561-292092-5
25	1	293455	14GA BLU-291571-291583-24
24	1	293454	14GA BLK-291511-291571-8
23	1	293407	10GA RED-291561-291561-33
22	1	293409	16GA WHT-291583-291583-5
21	1	293414	16GA GRN-291511-291571-9
20	1	293415	16GA BLU-291571-291583-9
19	1	291401	14GA RED-291583-291583-6
18	1	293406	10GA WHT-291561-291561-30
17	1	291535	BATTERY CABLE, 84" BLACK
16	1	291534	BATTERY CABLE, 84" BLACK
15	1	291533	BATTERY CABLE, 74" RED
14	1	291532	BATTERY CABLE, 44" RED
13	1	610530	5 WIRE CONNECTOR
12	1	291029	10GA BLU-291513-291587-30
11	1	293452	16GA BLK-291559-291583-127
10	1	293451	16GA BRN-291559-291583-126
9	1	293457	12GA WHT-291561-291561-5
8	1	293423	GND WIRE ASSY, FUSE BOX
7	2	293410	16GA WHT-291571-291598-4
6	1	293375	ALTERNATOR WIRE HARNESS-DELOD
5	1	293459	12GA WHT-291561-292092-6
4	1	293293	GAUGE GND JUMPER WIRE ASSY
3	1	293292	GAUGE FMR JUMPER WIRE ASSY
2	1	293284	16GA WHT-291576-292053-10
1	1	293282	16GA GRN-291589-292053-10

LH WORKLIGHT

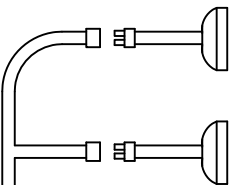

293437 - WORK LIGHT HARNESS

RH WORKLIGHT

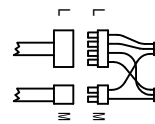
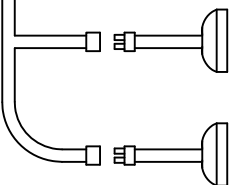

293503 - BOOM IND LIGHT SW PANEL HARNESS SHEET 5 OF 5

293511 - ENGINE WIRE HARNESS SHEET 1 OF 5

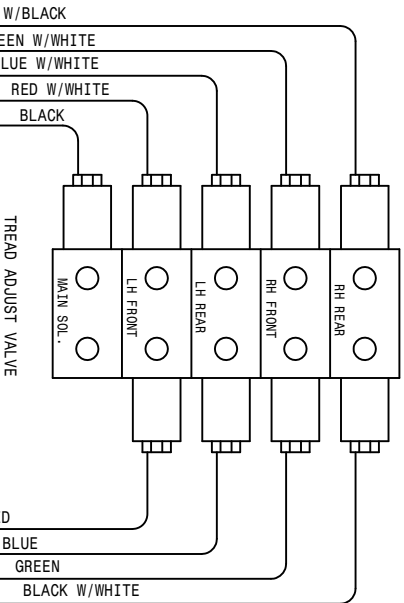

RED W/BLACK  
GREEN W/WHITE  
BLUE W/WHITE  
RED W/WHITE  
BLACK  
TREAD ADJUST VALVE  
MAIN SOL.  
LH FRONT  
LH REAR  
RH FRONT  
RH REAR  
RED  
BLUE  
GREEN  
BLACK W/WHITE

293449 - TREAD ADJUST VALVE HARNESS

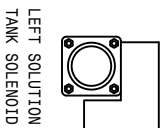

LEFT SOLUTION TANK SOLENOID

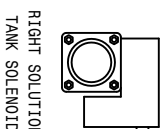

RIGHT SOLUTION TANK SOLENOID

293446 - SOLU TANK VLV WIRE ASSY

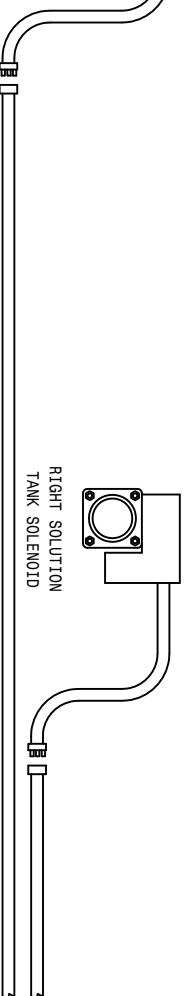

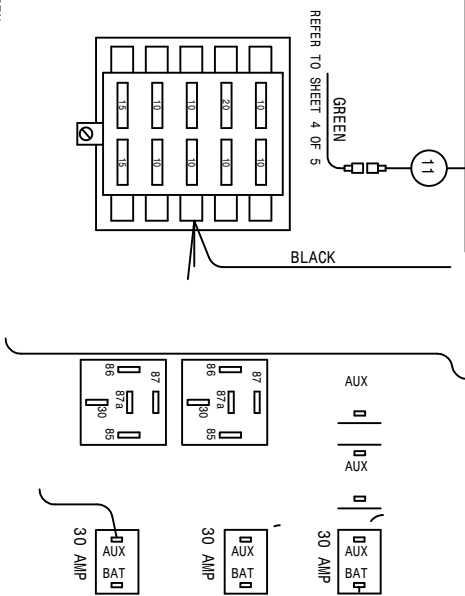
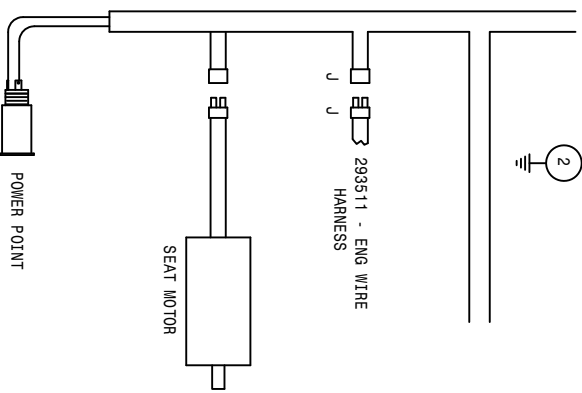
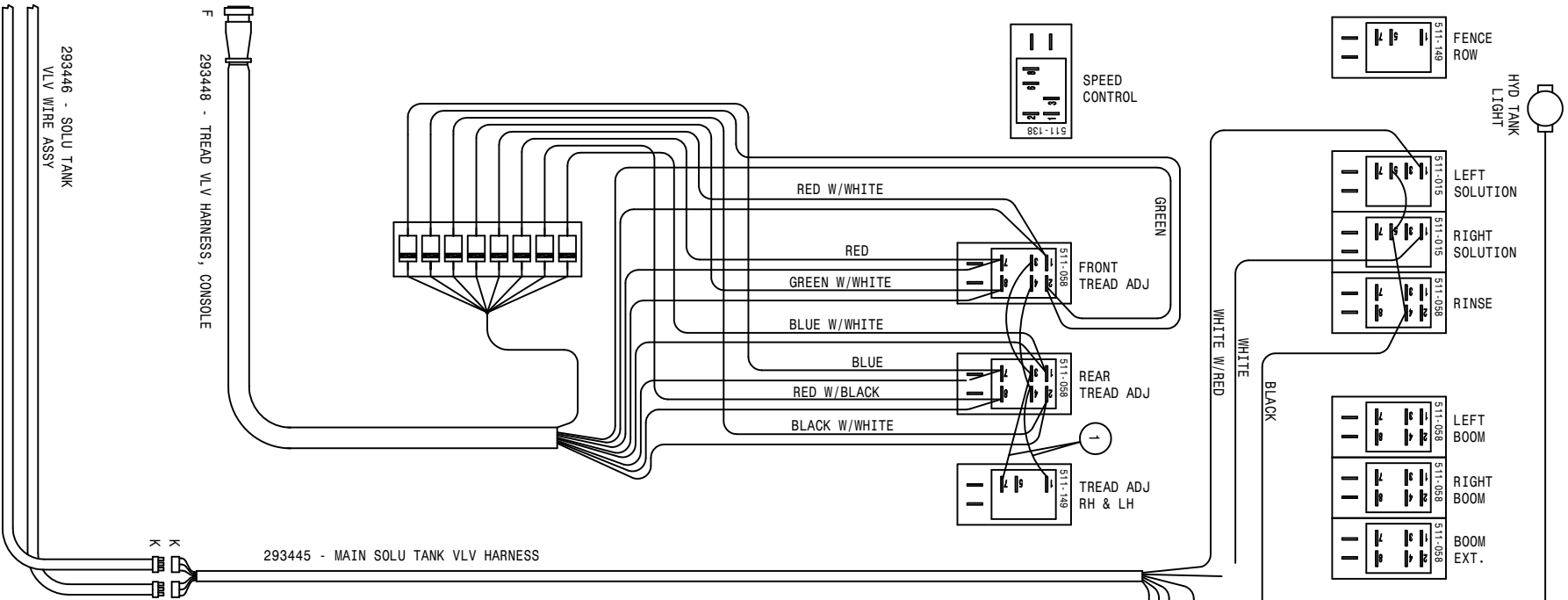

AA SHEET 1 OF 5

11	1	293548	14GA GRN-291571-291343-18
10	1	293499	16GA BRN/VEL-291583-291417-28
9	1	293413	16GA RED-291583-291583-15
8	1	293411	16GA BLK-291511-291583-18
7	1	293408	12GA BLK-294561-292092-26
6	1	293421	BRNKE/FUEL SW GND WIRE ASSY
5	1	293420	BRNKE/FUEL SW PARK WIRE ASSY
4	1	293417	MAIN SW LIGHT PARK WIRE ASSY
3	1	293418	MAIN SW LIGHT GRND WIRE ASSY
2	1	293423	GND WIRE ASSY, FUSE BOX
1	2	293427	TREAD ADJ SW PARK WIRE

2100 WIRING DIAGRAM 01

SHEET 2 OF 5

REVISION DATE: 10-02-01

498614

09-15-00

GSA



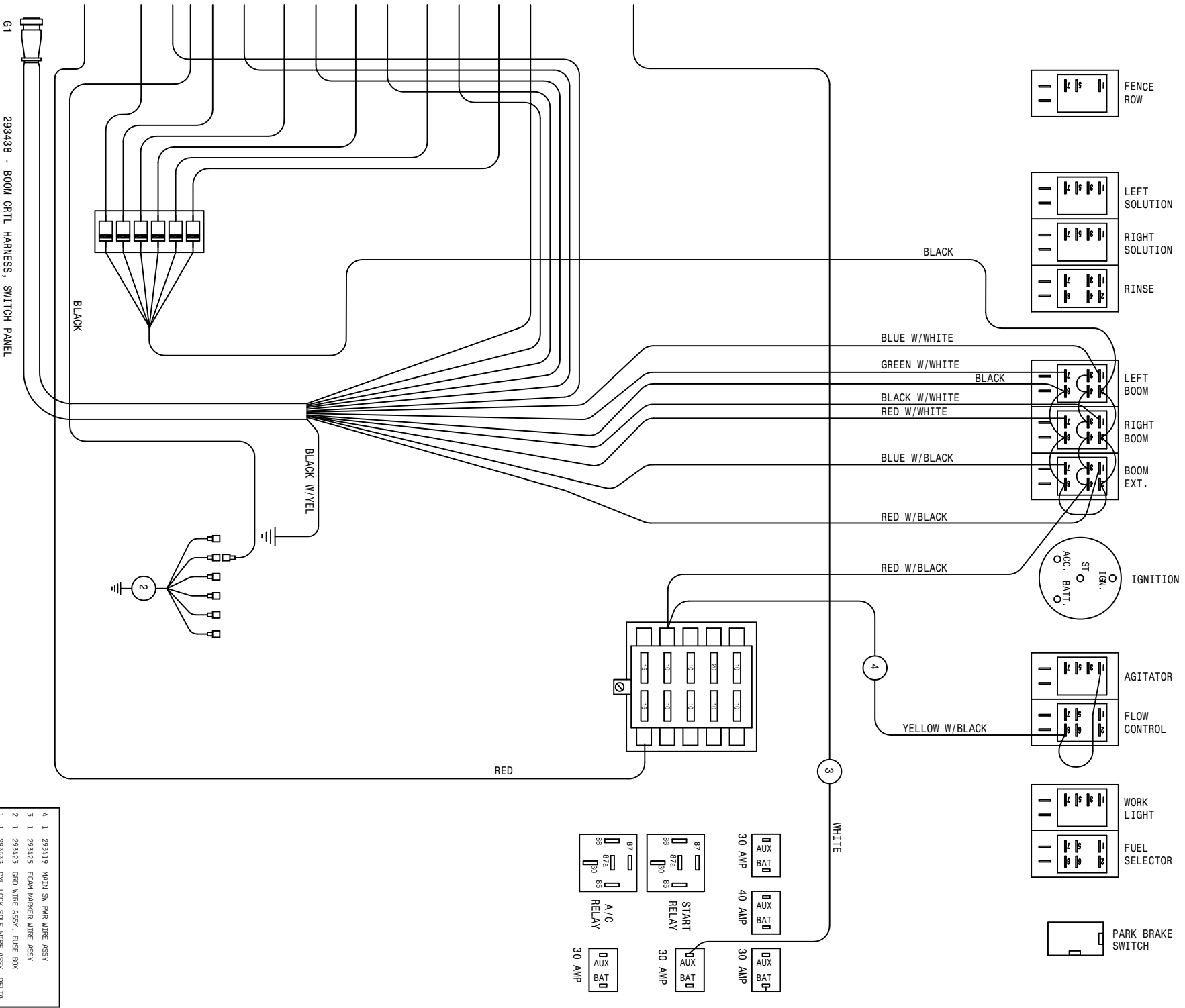

293438 - BOOM CRTL HARNESS, SWITCH PANEL

4	1	293419	MAIN SW PWR WIRE ASSY
3	1	293425	FOAM MARKER WIRE ASSY
2	1	293423	GRD WIRE ASSY, FUSE BOX
1	1	2939333	CYL LOCK SOLE WIRE ASSY, DELTA

2100 WIRING DIAGRAM 01

08-15-00 596

SHEET 3 OF 5  
REVISION DATE:  
498614

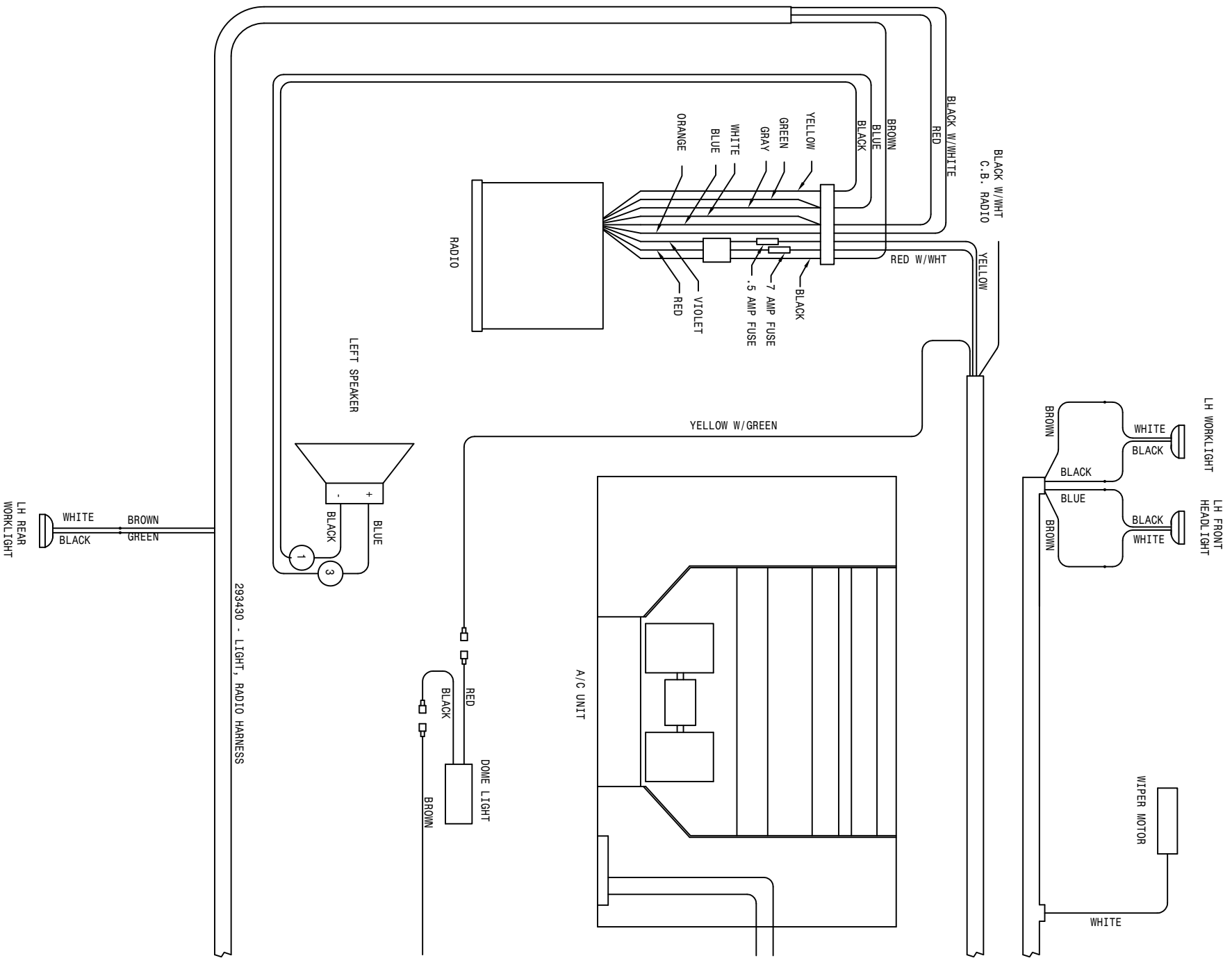

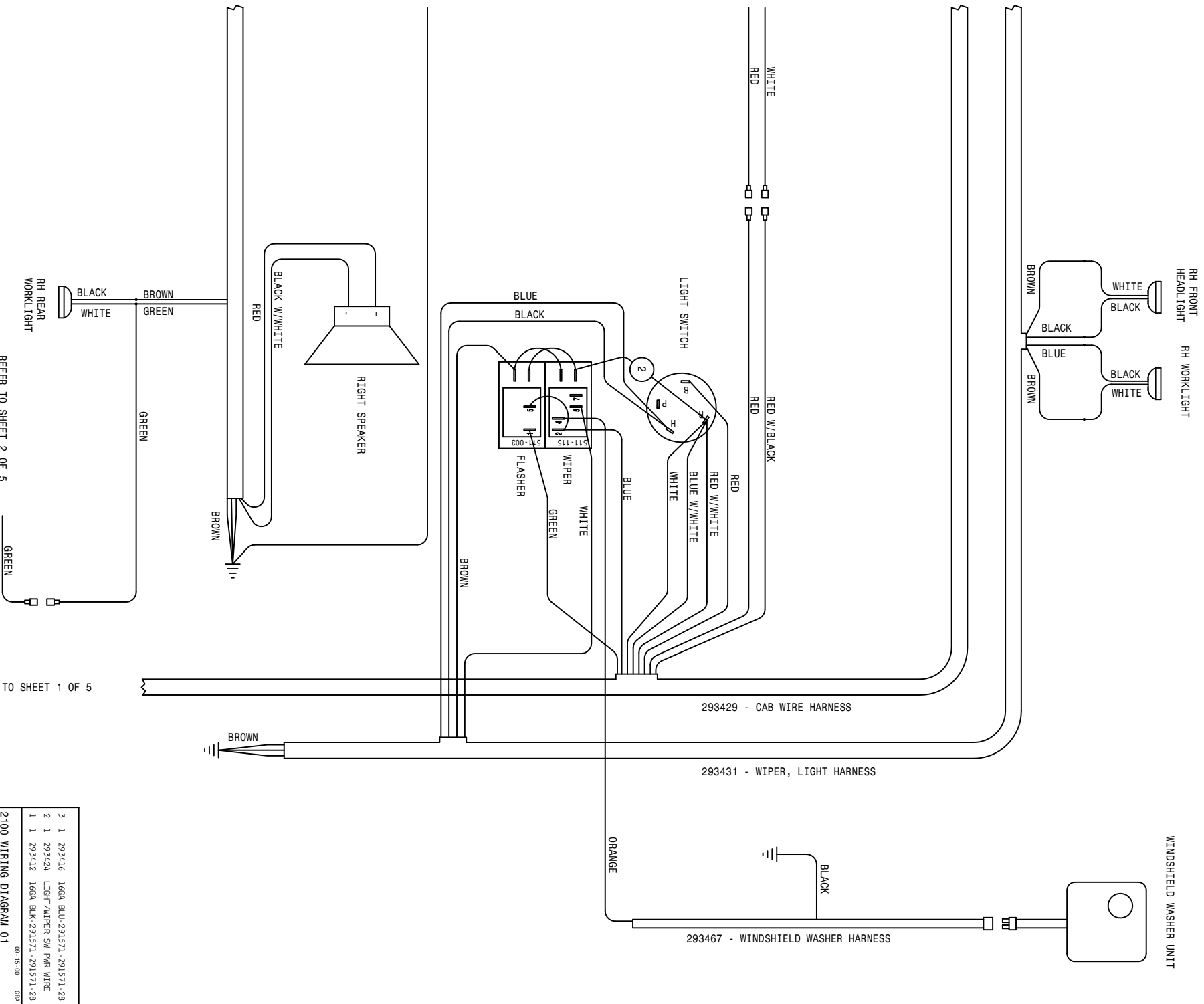

REFER TO SHEET 1 OF 5

REFER TO SHEET 2 OF 5

3	1	293416	16GA	BLU-291571-291571-28	
2	1	293424		LIGHT/WIPER SW PWR WIRE	
1	1	293412	16GA	BLK-291571-291571-28	

2100 WIRING DIAGRAM 01 09-15-00 GM

SHEET 4 OF 5  
 REVISION DME: 03-28-01

**498614**

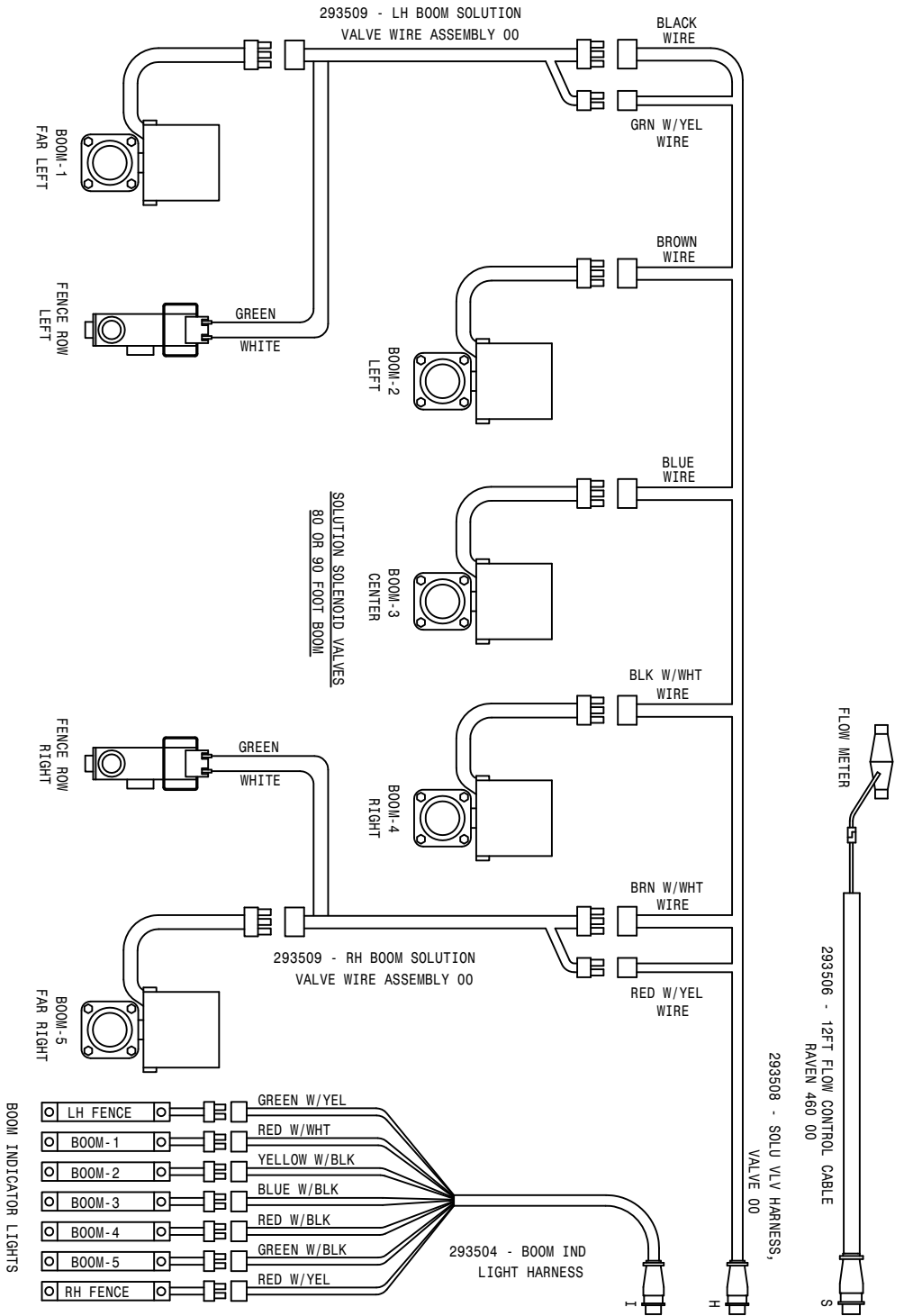
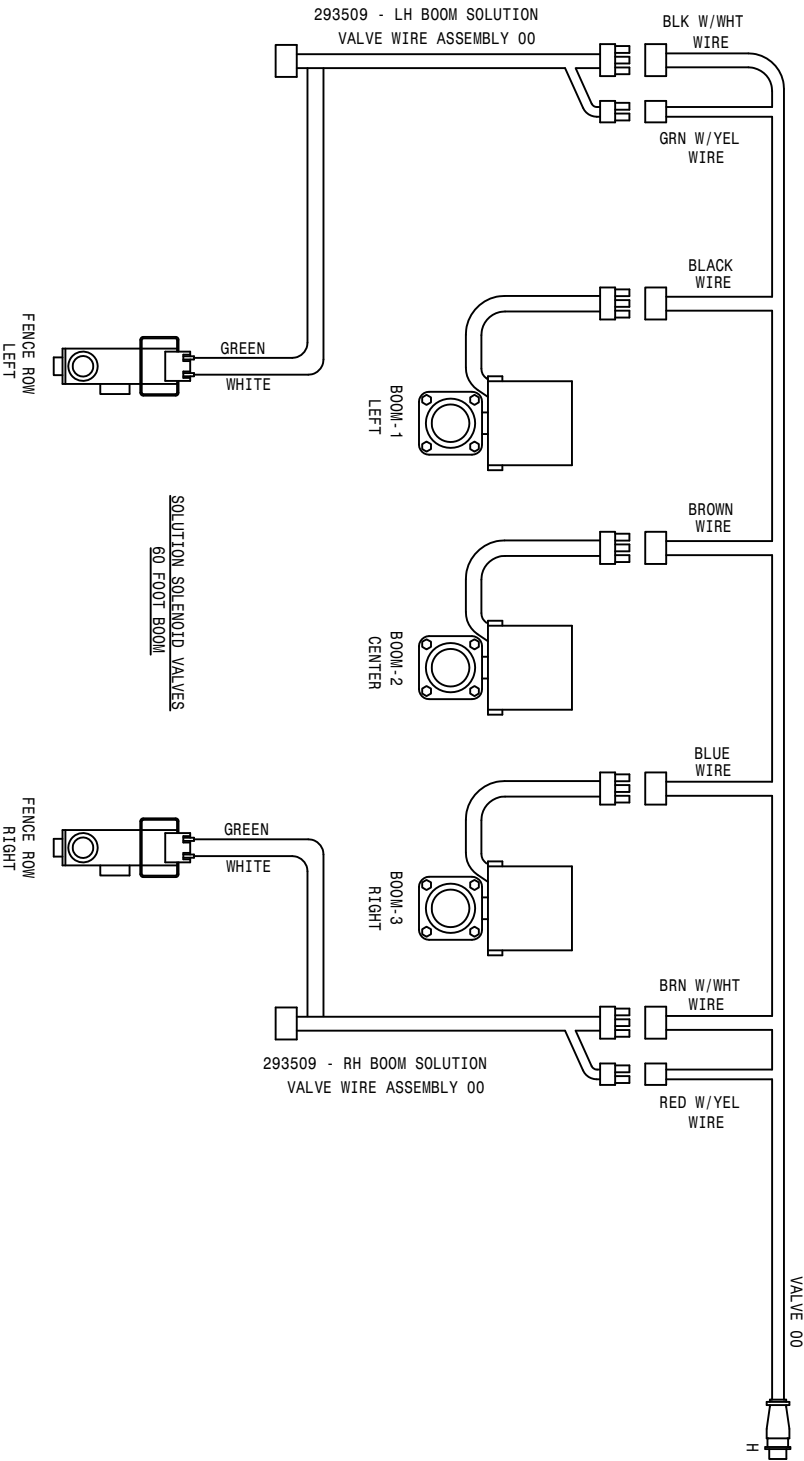



293437 - WORK LIGHT  
HARNESS  
SHEET 2 OF 5

293503 - BOOM IND LIGHT  
CONSOLE HARNESS

293505 - CONSOLE CONTROL CABLE RAVEN 460 98

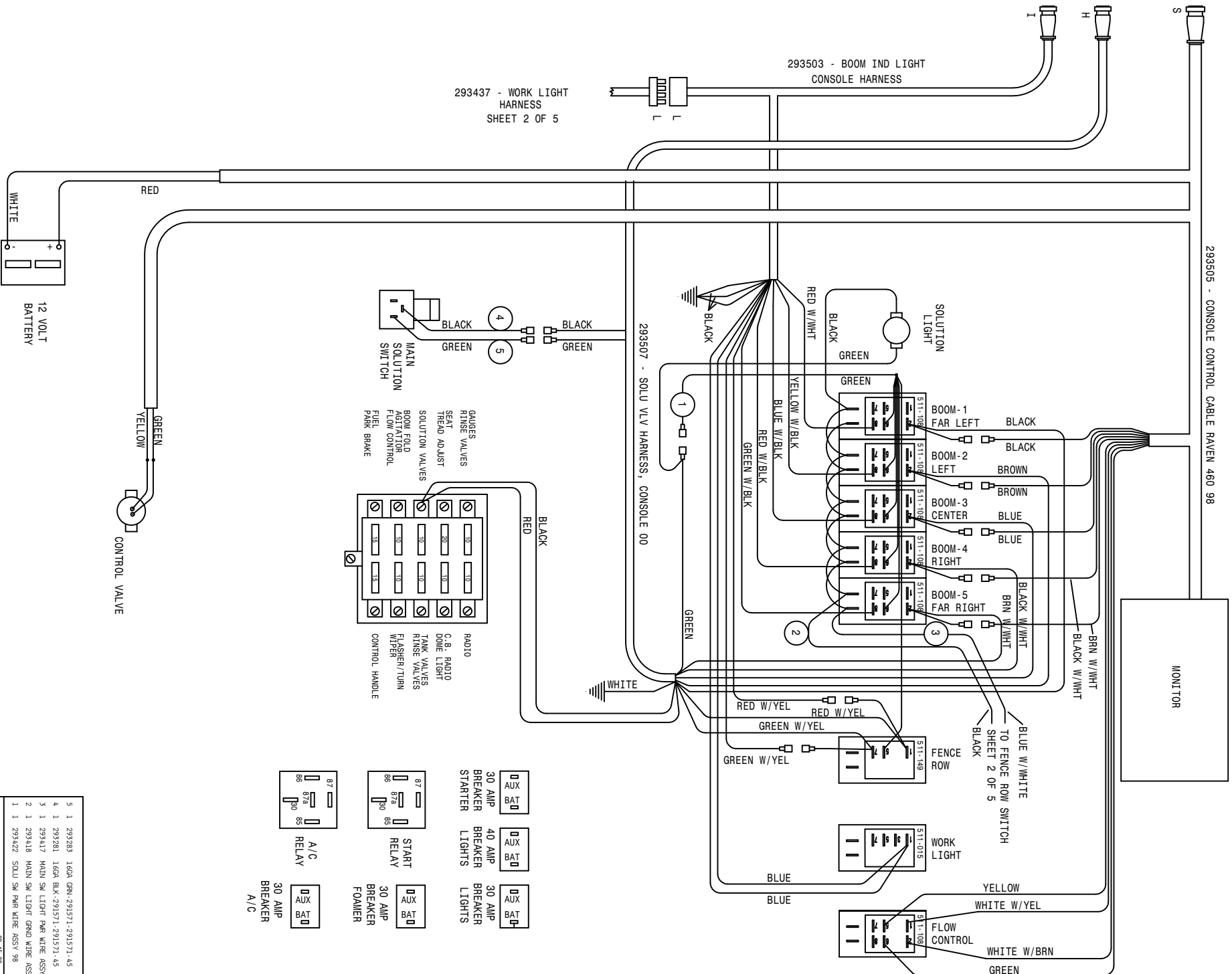

5	1	293283	1.6GA GRN-291571-291571-45
4	1	293281	1.6GA BLK-291571-291571-45
3	1	293417	MAIN SW LIGHT PAR WIRE ASSY
2	1	293418	MAIN SW LIGHT GRND WIRE ASSY
1	1	293422	SOLU SW PARK WIRE ASSY 98

2100 WIRING DIAGRAM 01  
09-15-00 GSA  
498614

SHEET 5 OF 5  
REVISED DATE: 10-10-00

ABBREVIATIONS

A/C - AIR CONDITIONER	MT - MOUNT
ADPTR - ADAPTER	MTR - MOTOR
AGI - AGITATOR	P/N - PART NUMBER
ALT - ALTERNATOR	PLT - PLATE
ASSY - ASSEMBLY	QTY - QUANTITY
BRKT - BRACKET	RED - REDUCER
DET - DETAIL	REF - REFERENCE
DISPL - DISPLACEMENT	REST - RESTRICTOR
EL - ELBOW	REQ - REQUIRED
EXT - EXTENSION	SHFT - SHAFT
FLO - FLOW	SOL - SOLUTION
FNPT - FEMALE NATIONAL PIPE THREAD	STRG - STEERING
FOR - FEMALE O-RING	ST - STREET
FRT - FRONT	SWIV - SWIVEL
HYD - HYDRAULIC	UNC - UNIFIED NATIONAL COURSE
HYDRO - HYDROSTATIC	UNF - UNIFIED NATIONAL FINE
LG - LONG	V - VOLT
LWR - LOWER	W/ - WITH
MJIC - MALE J.I.C.	WHL - WHEEL
MOR - MALE O-RING	WLD - WELDMENT

INDEX

-A-

ABBREVIATIONS.....130  
ACCUMULATOR CYLINDER..... 84,85  
AGITATOR  
    IMPELLER..... 61,63  
    SHAFT..... 61,63  
    SHIELD..... 61,63  
    SOLUTION..... 61,63  
    VARIABLE FLOW CONTROL..... 15  
AIR BAG..... 22,24,26,28  
AIR CLEANER.....33  
    BAND.....33  
    FILTER.....33  
    HOOD.....33  
    HOSE.....33  
AIR CONDITIONER.....36  
    BLOWER.....36  
    COMPRESSOR..... 5  
    CONDENSOR..... 19  
    DRYER..... 19  
    EVAPORATOR.....36  
    FILTER.....36  
    AIR INTAKE..... 19  
    AIR LINE..... 9,45  
    AIR REGULATOR.....45  
    AIR SEAT.....47  
    AIR TANK..... 8,9  
ANTENNA.....36

-B-

BATTERY.....58  
    BOX.....58  
    CABLE.....58  
    HOLD DOWN.....58  
BEARING, LEG..... 22,24,26,28  
BELT.....4,6  
BINDING POST.....44  
BLADE, WIPER.....34  
BLOWER MOTOR.....36  
BOOM.....90,91,92,93,94  
    CONTROL VALVE.....80,81  
    CRADLE.....56,57  
    HINGE..... 92,94  
    LIGHTS.....95  
    SOLENOID..... 64,65,66,67,68,69  
    SPRING.....86  
BOX FUSE.....46  
BREAKAWAY.....83  
BREAKER CIRCUIT.....4,46  
BUMPER, LEG.....22,24,26,28

-C-

CAB.....34  
    LIGHTS..... 34,36  
CABLE,  
    BATTERY.....58  
    GROUND.....4  
    HYDROSTATIC.....42  
    THROTTLE.....5,42  
CHEMICAL INDUCTOR..... 106  
CIRCUIT BREAKER.....4,46  
CLAMP,  
    AIR CLEANER.....33  
    MUFFLER.....32,33  
CONDENSOR.....19  
CONSOLE.....40,47  
CRADLE  
    BOOM.....56,57  
    SOLUTION TANK..... 60,62  
CROP GUIDE..... 23,25,27,29  
CYLINDER  
    ACCUMULATOR..... 84,85  
    FOLD.....88,89  
    LEVEL.....87  
    LIFT.....86  
    STEERING.....30  
TREAD ADJUST..... 101,102

-D-

DECALS.....112  
DIAGRAMS, WIRING..... 120  
DOOR.....35  
    LATCH.....35  
DRAIN VALVE..... 8,9  
DRINK HOLDER.....41  
DRIVE DISK.....5  
DYER, A/C..... 19  
BELT.....4,6

-E-

ENGINE.....4,5  
    HOOD.....48  
EXHAUST STACK.....32

-F-

FAN.....4  
    SPACER.....4  
FEEDER TEE.....78

FENCE ROW.....71,72,73  
 FILTER,  
 AIR CLEANER.....33  
 AIR CONDITIONER.....36  
 ENGINE.....4  
 FUEL.....5  
 HYDRAULIC.....11  
 MINDER.....48  
 FLOW DIVIDER.....14,16  
 FLOW METER.....64,65,67,68  
 FLUSHING VALVE.....10  
 FOAM.....34,37  
 FOAMER TANK.....98  
 FOAMER VALVE.....110  
 FOLD CYLINDER.....88,89  
 FUEL,  
 SELECTOR VALVE.....54  
 STRAINER.....5  
 TANK.....54  
 TANK MOUNT.....52,53  
 FUSE.....46  
 BOX.....46

-G-

GAS SPRING.....38,41,48  
 GAUGE  
 AIR REGULATOR.....45  
 OIL PRESSURE.....39  
 PRESSURE.....45,64,65,67,68  
 TEMPERATURE.....39  
 TREAD ADJUST.....55  
 GRAB HANDLE.....34  
 GLASS.....34,35  
 GROUND CABLE.....4  
 GROUND STRAP.....34  
 GUIDE, STALK.....23,25,27,29

-H-

HANDLE,  
 DOOR.....35  
 GRAB.....34  
 HANDRAIL.....55  
 HEADLIGHT.....34,59,82  
 HEADLINER.....36  
 HEATER COIL.....36  
 HINGE, BOOM.....92,94  
 HOOD,  
 AIR CLEANER.....33  
 ENGINE.....48  
 HOOK, RUBBER.....39  
 HOSE, RADIATOR.....4  
 HOSING, SOLUTION.....74,75,76,77  
 HOUR METER.....39  
 HUB, TORQUE.....23  
 HYDRAULIC

DAMPER.....35  
 FILTER.....11  
 SOLENOID VALVE.....12  
 SCHEMATIC.....114  
 TANK.....20  
 HYDROSTATIC  
 CABLE.....42  
 LEVER.....42

-I-

IGNITION SWITCH.....44  
 INDUCTOR, CHEMICAL.....106  
 INJECTION PLATFORM.....109  
 INSTRUMENT PANEL.....39

-L-

LADDER.....52,53  
 LATCH, DOOR.....35  
 LEG,  
 BEARING.....22,24,26,28  
 BRACE.....59  
 BUMPER.....22,24,26,28  
 FRONT.....22,24  
 REAR.....26,28  
 LEVEL CYLINDER.....87  
 LEVER,  
 HYDROSTATIC.....42  
 THROTTLE.....43  
 LIFTARM.....82  
 LIFT CYLINDER.....86  
 LIGHT,  
 BOOM.....95  
 CAB.....34,36  
 SWITCH.....36

-M-

MIRROR.....34  
 MOTOR  
 BLOWER.....36  
 STEERING.....38  
 WHEEL.....23,25,27,29  
 WIPER.....34  
 MOUNT,  
 CAB.....34  
 MOTOR.....4,5  
 PUMP.....7  
 MUFFLER.....32  
 CLAMP.....32,33  
 MULLION.....48

-N-

NOZZLE, REAR WHEEL.....107  
 NOZZLE, RINSE.....97

-0-  
OIL  
COOLER.....19  
PRESSUR.....39  
SENDER.....5  
TANK.....20

-P-  
PAD, RADIATOR.....19  
PANEL, SWITCH.....44  
PLATFORM, INJECTION.....109  
POWER POINT.....47  
PRESSURE  
GAUGE.....45, 64, 65, 67, 68  
WASHER.....104  
PUMP,  
SOLUTION.....99  
SUNDSTRAND.....7

-Q-  
QUICK FILL.....70

-R-  
RADAR.....108  
RADIATOR.....19  
HOSE.....4  
PAD.....19  
RECOVERY TANK.....50  
SHROUD.....19  
RADIO.....36  
RAVEN, VFC.....17  
REAR WHEEL NOZZLE.....107  
RELAY.....46  
RELIEF VALVE.....14  
RETURN TEE ASSEMBLY.....18  
RIM.....21  
RINSE  
NOZZLE.....97  
TANK.....96  
RUBBER,  
HOOK.....48  
MOUNT.....4, 5, 7, 34

-S-  
SCHEMATIC, HYDRAULIC.....114  
SEAT.....47  
SENDER,  
OIL.....5  
TEMPERATURE.....4  
SERVICE PLATFORM.....55

SHEET METAL.....48, 49  
SHIELD, TANK.....59  
SHROUD, RADIATOR.....19  
SIDERAIL.....55  
SMV SIGN.....55  
SOLENOID, BOOM. 64, 65, 66, 67, 68, 69  
SOLUTION  
HOSING.....74, 75, 76, 77  
PUMP.....79  
TANK CRADLE.....60, 62

SPACER, FAN.....4  
SPEAKER.....36  
SPRING, GAS.....38, 41, 38  
STALK GUIDE.....23, 25, 27, 29  
STEERING  
COLUMN.....38  
CYLINDER.....38  
MOTOR.....38  
WHEEL.....38  
STRAINER,  
FUEL.....5  
SOLUTION.....60, 62  
STRAP, GROUND.....34  
SUNDSTRAND PUMP.....7  
SWITCH,  
IGNITION.....44  
LIGHT.....44  
PANEL.....44  
SOLUTION.....34

-T-  
TAILLIGHT.....55  
TANK,  
AIR.....8, 9  
FOAMER.....98  
HYDRAULIC.....20  
MOUNTS.....59  
RADIATOR RECOVERY.....50  
RINSE.....96  
SHIELD.....59  
SOLUTION.....60, 62  
TEE, FEEDER.....78  
TEMPERATURE  
GAUGE.....39  
SENDER.....4  
THROTTLE CABLE.....5, 43  
TIE PLATE.....13  
TIE ROD.....31  
TIRE.....21  
TRANSOM.....75  
TREAD ADJUST.....100  
CYLINDER.....101, 102  
GAUGE.....55  
VALVE.....103  
TORQUE, HUB.....23, 25, 27, 29

-V-

VALVE,	
AIRBAG.....	23, 24, 26, 28
DIVERT, FOAMER.....	110
DRAIN.....	8
ELECTRIC BOOM.....	80, 81
FENCE ROW.....	71, 72, 73
FLUSHING.....	10
FUEL SELECTOR.....	54
HYDRAULIC SOLENOID.....	12
RELIEF.....	14
TREAD ADJUST.....	103
VARIABLE FLOW CONTROL.....	13, 15, 17
VOLTMETER.....	39

-W-

WASHER, PRESSURE.....	104
WHEEL MOTOR.....	23, 25, 27, 29
WHEEL, STEERING.....	38
WINDSHIELD WASHER.....	51
WIPER,	
BLADE.....	34
MOTOR.....	34
WINDSHIELD.....	34



# PARTS ORDER FAX

**Fax**  
**24 hours**  
**a day**  
**7 days**  
**a week\*\***

Ph. 1 (800) 247-4885    Fx. 1 (515) 532-3553

Photocopy and fax to Hagie Customer Support Department

ORDERED BY/BILL TO:

Name \_\_\_\_\_  
Co. Name \_\_\_\_\_  
Street \_\_\_\_\_  
City, St, Zip \_\_\_\_\_  
Ph. \_\_\_\_\_ Fx. \_\_\_\_\_

SHIP TO:

Name \_\_\_\_\_  
Co. Name \_\_\_\_\_  
Street \_\_\_\_\_  
City, St, Zip \_\_\_\_\_  
Ph. \_\_\_\_\_ Fx. \_\_\_\_\_

HOW SHIP:    UPS Ground    Next Day    2 Day    3 Day    Other \_\_\_\_\_

If "HOW SHIP" is left blank, parts will be sent UPS ground service. If part is over 150 pounds, an independent motor freight company will be used.

**PAYMENT:**    Hagie Account #\*\*\* \_\_\_\_\_

C.O.D

American Express    Discover    Visa    Master Card

Signature: \_\_\_\_\_  
name as appears on card: \_\_\_\_\_  
card no. \_\_\_\_\_ exp. date \_\_\_\_\_

Year and Model No. \_\_\_\_\_

Serial No. \_\_\_\_\_

Item Serial No. (if necessary): \_\_\_\_\_

Engine (include type) \_\_\_\_\_

Hydrostatic Pump (s) \_\_\_\_\_

Torque Hub \_\_\_\_\_  LF    RF    LR    RR

Wheel Motor \_\_\_\_\_  LF    RF    LR    RR

HAGIE Part No.	Qty.	Description

Check here if you want phone confirmation of parts order.

\* Orders received before 3:00 p.m., CST will be processed the same business day.

Regular business hours are Monday through Friday, 7:00 a.m. through 5:00 p.m..

\*\* If you do not have a Hagie account number, contact the Hagie Customer Support Department and you will be issued one.



# PARTS ORDER FAX

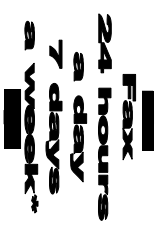

Ph. 1 (800) 247-4885    Fx. 1 (515) 532-3553

Photocopy and fax to Hagie Customer Support Department

ORDERED BY/BILL TO:

Name \_\_\_\_\_  
 Co. Name \_\_\_\_\_  
 Street \_\_\_\_\_  
 City, St, Zip \_\_\_\_\_  
 Ph. \_\_\_\_\_ Fx. \_\_\_\_\_

SHIP TO:

Name \_\_\_\_\_  
 Co. Name \_\_\_\_\_  
 Street \_\_\_\_\_  
 City, St, Zip \_\_\_\_\_  
 Ph. \_\_\_\_\_ Fx. \_\_\_\_\_

HOW SHIP:    UPS Ground    Next Day    2 Day    3 Day    Other \_\_\_\_\_

If "HOW SHIP" is left blank, parts will be sent UPS ground service. If part is over 150 pounds, an independent motor freight company will be used.

**PAYMENT:**    Hagie Account #\*\*\* \_\_\_\_\_

C.O.D

American Express    Discover    Visa    Master Card

Signature: \_\_\_\_\_  
 name as appears on card: \_\_\_\_\_  
 card no. \_\_\_\_\_ exp. date \_\_\_\_\_

Year and Model No. \_\_\_\_\_

Serial No. \_\_\_\_\_

Item Serial No. (if necessary): \_\_\_\_\_

Engine (include type) \_\_\_\_\_

Hydrostatic Pump (s) \_\_\_\_\_

Torque Hub \_\_\_\_\_     LF    RF    LR    RR

Wheel Motor \_\_\_\_\_     LF    RF    LR    RR

HAGIE Part No.	Qty.	Description

Check here if you want phone confirmation of parts order.

\* Orders received before 3:00 p.m., CST will be processed the same business day.

Regular business hours are Monday through Friday, 7:00 a.m. through 5:00 p.m..

\*\* If you do not have a Hagie account number, contact the Hagie Customer Support Department and you will be issued one.