

**CALIFORNIA
Proposition 65 Warning**

Diesel engine exhaust and some of its constituents are known to the State of California to cause cancer, birth defects, and other reproductive harm.

**2021 204SP
OPERATOR'S MANUAL
493846**



HAGIE
CONTENTS

1 – INTRODUCTION

A Word From Hagie Manufacturing Company 1-1
About This Manual 1-1
Safety Messages Used In This Manual 1-2
Service and Assistance 1-2
Product Warranty 1-2
Identification 1-2
Specifications 1-5

2 – SAFETY AND PRECAUTIONS

Intended Use 2-1
Safety Precautions 2-1
Seat Belt 2-4
Rotating Beacon 2-5
Emergency Stop 2-5
Operator Presence Switch (OPS) 2-6
Emergency Exit 2-7
Fire Extinguisher 2-7
Safety Decals 2-8

3 – CAB

Seat - Operator 3-1
Seat - Operator (Air Suspended) 3-1
Operator's Station 3-2

4 – ENGINE AND DRIVE SYSTEMS

Engine - Starting 4-1
Engine Monitor 4-2
Hydrostatic Drive 4-5

5 – HYDRAULIC SYSTEMS

Hydraulic System 5-1

6 – ELECTRICAL SYSTEMS

Batteries 6-1
Battery Disconnect Switch 6-2
Fuses and Relays 6-3
Fuse and Relay Ratings 6-6

7 – DETASSELING SYSTEMS

Detasseling System Components 7-1
Detasseling System - Operation 7-7
Tasseltrol®/LS System 12™ 7-8

Tasseltrol Flowchart	7-18
----------------------------	------

8 – MAINTENANCE AND STORAGE

Service - Fluids	8-1
Service - Filters	8-8
Service - Lubrication	8-13
Service - Belts	8-15
Service - Bolt Torque	8-16
Service - Toe-In	8-17
Service - Air Springs	8-19
Service - Miscellaneous	8-19
Service Intervals	8-21
Storage	8-23

9 – MISCELLANEOUS

Transporting	9-1
Attachments - Assembly and Installation	9-6
Wheel Tread and Row Spacing	9-14
Handrail Extension - Removable	9-16
Troubleshooting	9-18



SECTION 1 – INTRODUCTION

A WORD FROM HAGIE MANUFACTURING COMPANY

Congratulations on the purchase of your 204SP Detasseler! We recommend that you review this operator's manual and become familiar with operating procedures and safety precautions before attempting to operate the machine.

As with any piece of equipment, certain operating procedures, service, and maintenance are required to keep your detasseler in top running condition. We have attempted herein to cover all of the adjustments required to fit varying conditions. However, there may be times when special care must be considered.

NOTE: The user is responsible for inspecting the detasseler and having parts repaired or replaced when continued use of the product causes damage or excessive wear to other parts.

Hagie Manufacturing Company reserves the right to make changes in the design and material of any subsequent machine without obligation to existing units.

Thank you for choosing a Hagie 204SP Detasseler and we ensure you of our continued interest and support in its optimal performance for you. We are proud to have you as a customer!

ABOUT THIS MANUAL

NOTICE

Any pictures or illustrations contained within this manual that depict situations with shields, guards, rails, or lids removed are for demonstration only. Keep all shields and safety devices in place at all times.

This manual will aid you in the proper operation and service of your machine. It is the responsibility of the user to read the operator's manual and comply with the correct and safe operating procedures, as well as maintain the product according to the service information provided in the *Maintenance and Storage Section* elsewhere in this manual.

Photographs and illustrations used in this manual are of general nature only. Some of the equipment and features shown may not be available on your machine.

Information described in this manual was correct at the time of printing. Because of Hagie Manufacturing Company's continuous product improvement, certain information may not be included in this manual. To obtain the most current operator's manual for your machine, please visit www.hagie.com.

Keep this manual in a convenient place for easy reference. This manual is considered a permanent fixture of the product. In the event of resale, this manual must accompany the machine.

If you do not understand any part of this manual or require additional information or service, contact your local John Deere dealer for assistance.

SAFETY MESSAGES USED IN THIS MANUAL

The following safety messages found throughout this manual alert you of situations that could become potentially dangerous to the operator, service personnel, or equipment.

DANGER

The signal word DANGER indicates a hazardous situation which, if not avoided, will result in death or serious injury.

WARNING

The signal word WARNING indicates a hazardous situation which, if not avoided, could result in death or serious injury.

CAUTION

The signal word CAUTION indicates a hazardous situation which, if not avoided, could result in minor or moderate injury. CAUTION may also be used to alert against unsafe practices associated with events which could lead to personal injury.

NOTICE

The signal word NOTICE indicates operator awareness which, if not avoided, may result in personal or property damage.

NOTE: A “Note” is intended to make special mention of, or remark on.

SERVICE AND ASSISTANCE

Please contact your local John Deere dealer for service and assistance.

PRODUCT WARRANTY

Please contact your local John Deere dealer for further information.

IDENTIFICATION

NOTICE

Reference to right and left-hand used throughout this manual refers to the position when seated in the operator’s seat facing forward.

Each machine is identified by means of a frame serial number. This serial number denotes the model, year in which it was built, and the number of the detasseler.

For further identification, the engine, hydrostatic pumps, and wheel motors each have serial numbers, and the planetary wheel hubs have identification plates that describe the type of mount and gear ratio.

To ensure prompt, efficient service when ordering parts or requesting service repairs, record the serial numbers and identification numbers in the following spaces provided.

Detasseler

The detasseler serial number is stamped on the rear right-hand side of machine.



Detasseler Serial Number
-Typical View

Serial No. _____

Engine

The engine has an identification plate located on top of the engine that provides engine serial number, as well as other manufacturer information. Refer to your Parts Manual for specific part number.

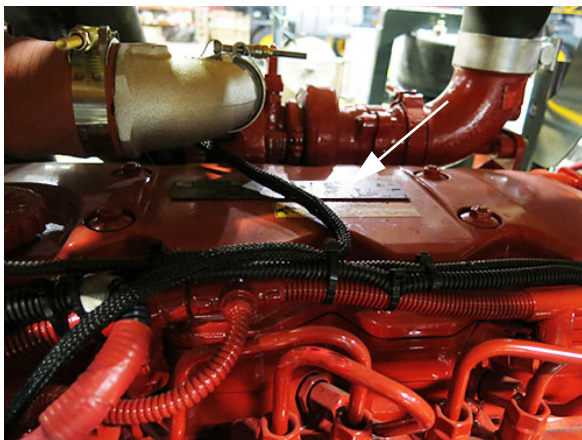

Engine Identification Plate
-Typical View

Serial No. _____

Hydrostatic Pumps

The hydrostatic pumps each have an identification plate mounted on the side of pump that provides pump serial number, as

well as other manufacturer information. Refer to your Parts Manual for specific part numbers.

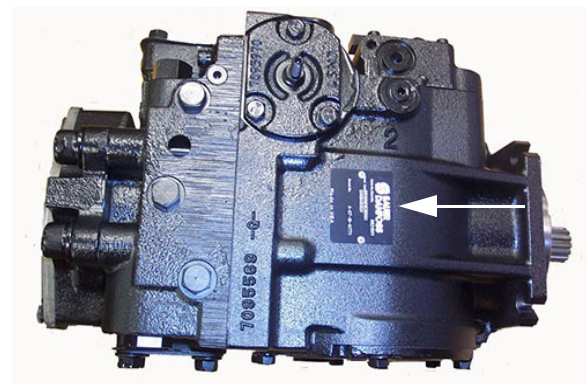

Hydrostatic Pump Identification Plate
-Typical View

_____ Left

_____ Right

Wheel Motors

The wheel motors each have an identification plate mounted on the side of motor that provides motor serial number, as well as other manufacturer information. Refer to your Parts Manual for specific part numbers.

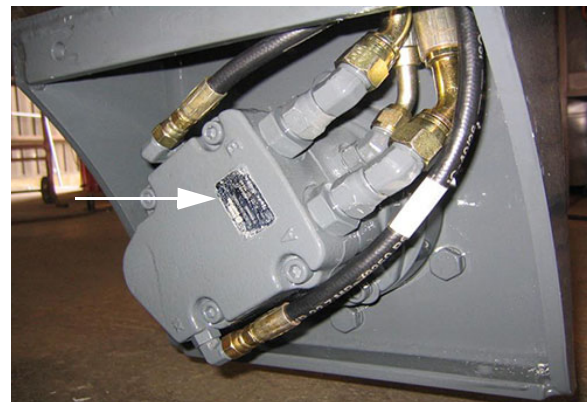

Front and Left Rear Wheel Motor
Identification Plate
-Typical View

_____ Left Front

_____ Right Front

_____ Left Rear

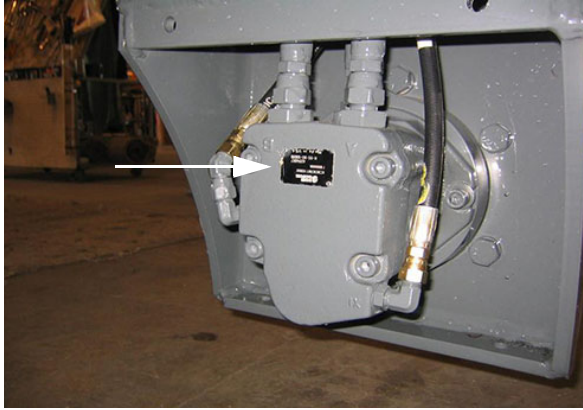

Right Rear Wheel Motor
(w/Sensor) Identification Plate
-Typical View

_____ Right Rear

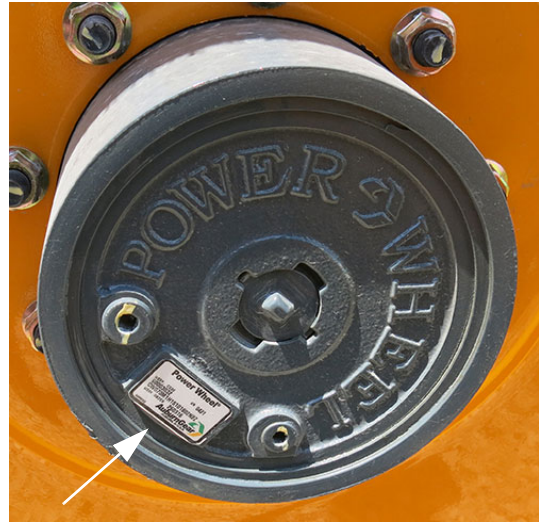

Planetary Wheel Hub Identification Plate
-Typical View

_____ Left Front

_____ Right Front

_____ Left Rear

_____ Right Rear

Wheel Hubs

The wheel hubs each have an identification plate mounted on the front of hub that provides hub serial number, as well as other manufacturer information, including gear ratio. Refer to your Parts Manual for specific part number.

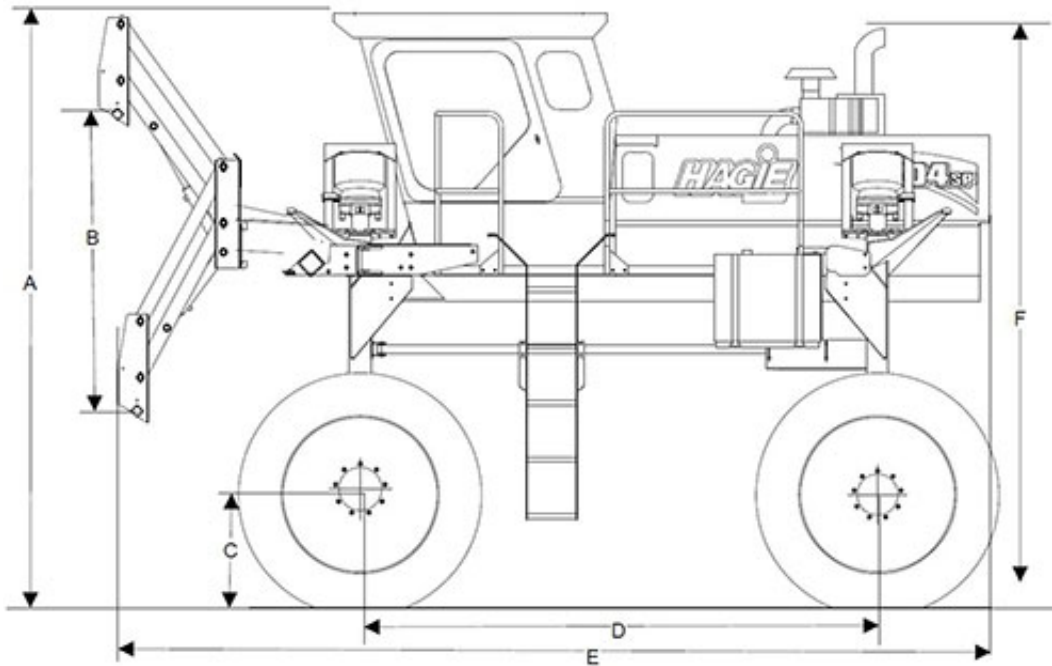
SPECIFICATIONS

Detail	Description	Specification
A	Overall Machine Height (cab or canopy)	144" (365.8 cm) <i>NOTE: Overall machine height with rotating beacon fully extended = 152" (386.1 cm)</i>
B	Lift Arm Range	66" (167.6 cm)
C	Axle Height	27" (68.6 cm)
D	Wheel Base	121" (307.3 cm)
E	Machine Length (no attachments) <i>NOTE: Dimension shown include rear weights.</i>	224" (569 cm)
F	Diesel Exhaust Height	146" (370.8 cm)
G	Center Clearance	77" (195.6 cm)
H	Frame Clearance	83" (210.8 cm)
I	Lower Leg Clearance (front)	22" (55.9 cm)
J	Tire Center to Inside of Lower Leg (front)	12.5" (31.8 cm)
K	Tread Width (adjustable)*	<ul style="list-style-type: none"> • Cab = 100-120" (254-304.8 cm) • Canopy = 89-120" (226.1-304.8 cm), w/ canopy open

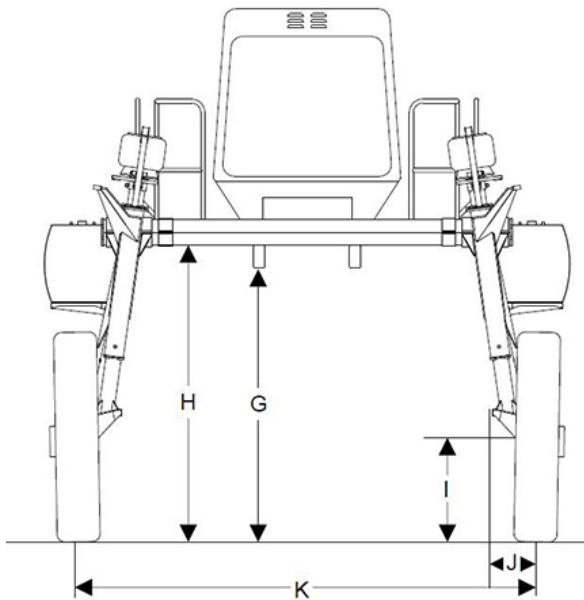

** Tread width is measured from center of tire at ground.*

General Information

NOTICE

Because Hagie Manufacturing Company offers a variety of options, the illustrations in this manual may show a machine equipped other than standard. Height and weight do not consider options. Values may vary, depending on available equipment.

- **Suspension:**
Rigid, 4-wheel, Independent Air Suspension
- **Shipping Width:**
138" (350.5 cm)
- **Approximate Dry Weight:**
10,200-13,800 lbs. (4,626-6,259 kg)

NOTE: Weight may vary depending on available equipment and shipping options.

Description	Specification
Engine	
Manufacturer	Cummins®
Model	QSB 4.5
Type	In-line, Liquid Cooled
Number of Cylinders	4
Displacement	4.5 Liters (274 c.i.)
Horse Power	160 hp (119 KW)
Fuel Type	No. 2 Diesel
Fuel System	Filtered, Direct-Injected
Air Cleaner	Dry-Type, Single Element
Engine Air Filter Restriction Monitor	Filter Minder®
Slow Idle	1000 RPM
Fast Idle	2600-2800 RPM
Hydrostatic Drive	
Hydrostatic Pump	Danfoss 90-Series
Drive Train	All-Time 4-Wheel Drive
Speed Ranges	<ul style="list-style-type: none"> • Low (0-12 mph/0-19 km/h) • High (0-15 mph/0-24 km/h)
Hydrostatic Wheel Motors	Danfoss K-38 w/Sensor
Final Drives	Planetary Gear Reduction Hubs
• Lubrication	Oil Bath
Brakes (Parking)	Multiple Disk, Spring Applied, Hydraulically Released
Steering System	Hydraulic, Priority on Demand
• Control	Full-Time Power
• Steering Cylinders	Double Acting
• Turning Radius	18 ft./5 m (with 120"/304.8 cm tread)
Auxiliary Hydraulic System	
Type	Open
Pump Type	Tandem Gear
Pressure Setting	2500 PSI (172.4 bar)

Electrical System	
General Electrical System	
• Battery	Single 12V, Negative Ground
• Alternator	130 AMP, Voltage Regulated
• Starter	12V w/Solenoid
Lights (Cab or Canopy)	
Front Cab	(4) Halogen Field Lights
Rear Cab	(2) Halogen Work Lights
Operator's Station	
Canopy (Standard)	
General Operator's Station	<ul style="list-style-type: none"> • Tilt Steering • Hazard/Warning Lights • Turn Signals • Side Mirrors
Seat	<ul style="list-style-type: none"> • Fore-Aft Adjustment • Ride Height • Ride Firmness
Cab (Optional)	
General Cab	<ul style="list-style-type: none"> • Tilt Steering • Hazard/Warning Lights • Turn Signals • Side Mirrors • Windshield Wiper • Side Mirrors • Dome Light • Tinted Glass
Temperature Control	Full Range
A/C Charge Type	R-134a
Fresh Air Filtration	<ul style="list-style-type: none"> • Charcoal Filter • Paper Filter
Seat	Air Ride
Instruments	
Dial Gauge	Fuel
Digital Gauges	<ul style="list-style-type: none"> • Speedometer (MPH-km/h) • Tachometer (RPM) • Oil Pressure • Coolant Temperature • Engine Hours • Fuel Rate • Systems Voltage

Stereo	AM/FM/Weather Band w/Dual Speakers
Tires/Rims	
Tires	11.2 - 38 (Bias TU)
• Air Pressure (Maximum)	26 PSI (1.8 bar)
• Tire Width	11.3" (28.7 cm)
• Load Capacity (25 mph-40 km/h)	2540 lbs. (1152 kg)
• Overall Diameter	57.4" (145.8 cm)
• Static Load Radius (suggested, may vary by load)	27.3" (69.3 cm)
• Rolling Circumference	170.8" (433.8 cm)
Rims	38" x 10" (96.5 x 25.4 cm)
Fluid Capacities	
Fuel Tanks (2)	40 Gallons (151 L)/each, <i>No. 2 Diesel Fuel</i>
Engine Oil (entire system)	15.9 Quarts (15 L), <i>15W-40 Diesel Engine Oil</i>
• Engine Oil Pan	13.7 Quarts (13 L)
• Engine Oil Dipstick (L-H mark)	3.2 Quarts (3 L)
Engine Cooling System (w/o cab heater)	5.1 Gallons (19.3 L), <i>Ethylene Glycol</i>
Hydraulic Oil Reservoir	18 Gallons (68 L), <i>Anti-Wear Hydraulic Oil</i>
Wheel Hubs	22 oz. (.7 L)/each, <i>75W-90 Gear Oil</i>
Detasseling System	
Quad Pullers	
• Number of Rows Available	4, 6, 8, 10, 12, or 18
• Drive	Hydraulic
• Tire Size	4.10/3.50 2-ply
• Tire Pressure	10 PSI (.7 bar)
• Operating Speed	<ul style="list-style-type: none"> • Min Speed = 375 RPM • Mid Speed = 400 RPM • Max Speed = 425 RPM <p><i>NOTE: It is recommended to set the quad pullers as close to "mid" speed range as possible.</i></p>
• Pulling Height	<ul style="list-style-type: none"> • Minimum Range - 32" to 97" (81.3 to 246.4 cm) • Maximum Range - 40" to 105" (101.6 to 266.7 cm)

SECTION 1 – INTRODUCTION



• Weight (per assembly)	86 lbs. (39 kg)
Cutters	
• Number of Rows Available	4, 6, 8, 10, 12, or 18
• Drive	Hydraulic
• Blade Size	18" (45.7 cm)
• Operating Speed	<ul style="list-style-type: none">• Min Speed = 2900 RPM• Mid Speed = 3000 RPM• Max Speed = 3100 RPM <p><i>NOTE: It is recommended to set the cutter heads as close to "mid" speed range as possible.</i></p>
• Cutting Height	<ul style="list-style-type: none">• Minimum Range - 29" to 94" (73.7 to 238.8 cm)• Maximum Range - 13" to 102" (33 to 259.1 cm)
• Weight (per assembly)	62 lbs. (28 kg)



SECTION 2 – SAFETY AND PRECAUTIONS

INTENDED USE

NOTICE

This machine is designed for and intended to be used for the removal of tassels from the tops of corn plants. Use in any other way or for any other purpose is considered misuse of this machine.

Most accidents occur as the result of failure to follow basic and fundamental safety rules and precautions. Recognizing potential safety hazards, following correct and safe operating procedures described in this manual, and complying with safety warnings located throughout the machine may reduce the risk of accidents.

There is no way to completely eliminate the potential for danger when operating agricultural equipment. Therefore, you must study this operator's manual and understand how to operate the detasseler controls for safe operation before using the detasseler, its attachments, or any detasseling equipment. Likewise, never let anyone operate the machine without proper instruction.

Do not operate the detasseler, its attachments, or any detasseling equipment for anything other than their intended uses. Hagie Manufacturing Company shall not be liable for any damage, injury, or death associated with improper use of the detasseler, its attachments, or any detasseling equipment.

Do not make any modifications such as, but not limited to, weldments, add-ons, adaptations, or changes from the original design of the detasseler. Such modifications may become safety hazards to you and others and **will void all warranties**.

Replace missing, faded, or damaged safety signs. Refer to "Safety Decals" elsewhere in this section for correct sign and placement.

SAFETY PRECAUTIONS

Do Not Bypass Safety Start

- Start the machine from the operator's seat only.



Use Caution While Driving

- Before moving the detasseler, ensure no persons or obstructions are in the path of travel.
- Do not drive under trees, bridges, wires, or other obstructions unless there is adequate clearance.
- Do not permit passengers to ride on machine while it is moving. Failure to comply may result in passenger falling off of machine and/or obstructing the operator's view.



- Never drive near ditches, embankments, holes, mounds, or other obstacles.
- Never drive on hills too steep for safe operation.

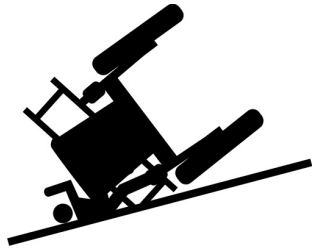

- Know and obey all state laws for driving agricultural equipment on a public roadway.
- Take caution when entering or exiting a public roadway.
- Always drive at a reasonable field speed to suit the conditions.
- Reduce machine speed while turning.

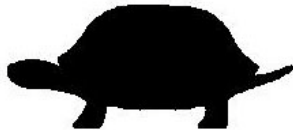

- Come to a complete stop before reversing direction.
- Pull over to the side of the road before stopping.
- Use flashing hazard/warning lights when traveling on public roadways, day or night, unless prohibited by law.
- Ensure the Slow Moving Vehicle (SMV) emblem and the Speed Indicator Symbol (SIS) are in place and visible from the rear of machine when traveling on public roadways.



SMV



SIS (mph)



SIS (km/h)

Operate Safely

General Operation Safety

- Do not adjust the factory engine RPM settings.

- Handle starting fluid with care. Keep it away from open flames. Store with the cap on and in a cool place.
- Do not look directly into the light sensing depth unit light beams, as it emits a low intensity microwave signal, which may cause possible eye damage.
- Keep all shields in place.
- Keep clear of all moving parts and keep others away when operating.
- Do not wear loose fitting clothing that may be blown or drawn into moving parts.
- Never allow walking personnel in the same field as the machine.

Tread Width

- Select the widest tread setting to fit between crop rows.
- Never manually adjust the machine's tread width until the wheels have been properly blocked. Loosen the leg clamp bolts only enough for the leg to slide on the frame.

Outriggers

- Ensure the outriggers are in the LOCKED position during fold procedure.
- Ensure the outriggers are in the FOLDED and LOCKED position when driving or transporting the machine.

Remove Paint Before Welding or Heating

- Avoid toxic fumes and dust. Hazardous fumes can be generated when paint is heated by welding, soldering, or using a torch.



- Do not use chlorinated solvents in areas where welding will take place.

- Perform all work in an area that is well ventilated to carry toxic fumes and dust away.
- Dispose of paint and solvents properly.

Avoid Heating Near Pressurized Lines

- Avoid torching, welding, and soldering near pressurized hydraulic lines. Pressurized lines may accidentally burst when heat goes beyond the immediate flame area.



Handle Fuel Safely

- Always turn engine off and allow it to cool before refueling.
- NEVER smoke while refueling.



- Do not fill fuel tanks completely, as fuel may expand and run over.
- Always clean up spilled fuel with soapy water.
- Keep a fire extinguisher nearby when refueling.

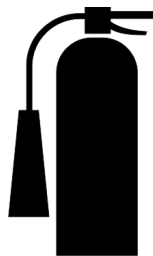

Be Prepared

- Be prepared for an emergency. Keep a fire extinguisher and first aid kit nearby.
- Service the fire extinguisher regularly. Keep an accurate inventory of supplies in the first aid kit and dispose of anything that has expired.

Protect Against Noise

- Operating equipment safely requires the full attention of the operator. Do not wear radio or music headphones while operating the machine.
- Prolonged exposure to loud noise may result in loss of hearing. Wear suitable hearing protection.



Battery Acid Accident Prevention

Avoid serious injury by avoiding battery acid contact with your body. Battery electrolyte contains sulfuric acid that is strong enough to eat holes in clothing and cause blindness if splashed into eyes.

Make sure to:

- Fill batteries in a well ventilated area.
- Wear Personal Protective Equipment (PPE) when servicing a battery.
- Avoid breathing in the fumes when recharging with electrolyte.
- Avoid spilling or dripping electrolyte.
- When charging a battery, connect positive cable to positive terminal and negative cable to negative terminal. Failure to comply may result in an explosion and/or personal injury.

If you spill on yourself:

- Flush affected area with cold water and remove contaminated clothes and shoes immediately. Continue to flush the area for a minimum of 15 minutes.



- Call a physician.
- While transporting or waiting for medical attention, apply compresses of iced water or immerse affected area in iced water. **DO NOT ALLOW SKIN TISSUE TO FREEZE.**
- Do not apply creams or ointments until you have been seen by a physician.

If acid is swallowed:

- Do NOT induce vomiting.
- Drink large amounts of water.
- Seek medical attention immediately!
- Do not neutralize the acid.

If fumes are inhaled:

- Move the person into fresh air.
- Do not give artificial respiration to a person that is able to breath on their own.
- Give CPR only if there is no breathing and no pulse.
- Seek medical attention immediately!

Safe Hydraulic Maintenance

- Always practice personal safety when performing service or maintenance on the hydraulic system.
- Use caution when working around hydraulic fluid under pressure. Escaping fluid can have sufficient force to penetrate your skin, possibly resulting in serious injury. This fluid may also be hot enough to burn.

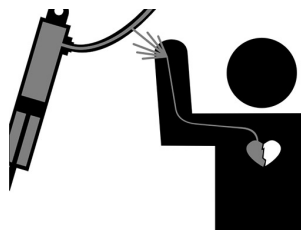

- Always lower the load or relieve the pressure before repairing a hydraulic oil leak.

Beware of Exhaust Fumes

- Never run the machine in a closed building. Proper ventilation is required. Use an exhaust pipe extension to remove fumes if you must operate in a building. Also, open doors and windows to bring in enough outside air into the area.

General Maintenance Safety

- Turn off engine before checking, adjusting, repairing, lubricating, or cleaning any part of the machine.
- When servicing the radiator, let the engine cool before removing pressurized cap.



- Disconnect battery ground cable and turn the Battery Disconnect Switch OFF before servicing the electrical system or welding on the machine.



- When charging the battery, connect the positive cable to the positive terminal and the negative cable to the negative terminal. Failure to comply may result in an explosion and cause injury.
- Never pressurize suspension air bags over 100 psi (6.9 bar).

SEAT BELT

For your safety, wear seat belt at all times when operating the machine.

Seat Belt Operation

- Grasp the Seat Belt Buckle (located on the outward side of seat) and extend all the way across your hips, seated below your abdomen.
- Insert the buckle tongue into the receptacle assembly (located on the opposite side of seat) and engage into LOCKED position.
- **To release Seat Belt**, press the Release Button (located on the receptacle end) and allow belt to retract.

Inspection/Replacement

Inspect seat belt and mounting hardware yearly. Replace seat belt if anchorage system, buckle, belt, or retractor shows signs of damage, including evidence of cuts, fraying or wear, discoloration, or being heavily soiled - especially with oil grease or fuel. Replace only with replacement parts approved for your machine.



Rotating Beacon
(Located on the left-hand
side of the operator's station)
-Typical View

ROTATING BEACON

-If Equipped

The Rotating Beacon (located on the left-hand side of the operator's station) is used for increased visibility to others. The beacon will illuminate when the Hazard/Warning Lights Switch is activated.

EMERGENCY STOP

(E-Stop)



NOTICE

Do not use the E-Stop Switch for non-emergency stopping or as a parking brake.

The E-Stop Switch (located near the side console) provides a quick and positive method for stopping the engine in an emergency situation.

SECTION 2 – SAFETY AND PRECAUTIONS



When the E-Stop Switch is depressed, it locks in position and removes the ignition signal to shut down the engine. To reset the E-Stop Switch, turn the switch in the direction of the arrows (located on the face of the button).



E-Stop Switch
(Located near the side console)
-Typical View



Operator Presence Switch
(Located inside the operator's seat)
-Typical View

To Reactivate the Cutter Heads and Quad Pullers:

NOTE: The operator must be seated in the operator's seat before reactivating the detasseling heads.

- Press the Master Detasseler Switch (located on the side console) in the DOWN (Off) position.

OPERATOR PRESENCE SWITCH (OPS)

The Operator Presence Switch (located inside the operator's seat) protects the operator from exposure to moving parts or hazards when operating the detasseler cutter heads and quad pullers.

This safety feature introduces an electrical interlock that ensures that when the operator is out of the operator's seat, the operation of these functions have stopped. This is achieved by using the OPS to prevent the detasseler assemblies from operating if the operator is not seated in the operator's seat for three (3) seconds.



Master Detasseler Switch
(Located on the side console)
-Typical View

- Return the engine to idle.
- Press the Master Detasseler Switch in the UP (On) position for all functions to resume.

EMERGENCY EXIT
(Cab machines only)



⚠ CAUTION

Do not look directly at the glass when using the Emergency Exit Tool. Failure to comply may result in personal injury.

NOTICE

The Emergency Exit Tool is a permanent fixture of the machine. Do not remove from cab under any circumstances.

In the event of an emergency, use the cab door to exit the machine. Should the cab door become inoperable, an Emergency Exit Tool (located near the left-hand side of cab) is provided and is used in the rare event to shatter the glass of the cab.

- Press the Emergency Exit Tool firmly against the glass to automatically trigger and shatter the glass.



Emergency Exit Tool
(Located near the left-hand side of cab)
-Typical View

FIRE EXTINGUISHER

–If Equipped

Your machine may be equipped with a Fire Extinguisher (located along side of the operator's seat).

In the event that use of the Fire Extinguisher is required, follow the manufacturer's operating instructions provided on the Fire Extinguisher.

To Remove Fire Extinguisher

- Pull the Security Latch **OUTWARD** to disengage and remove Fire Extinguisher.



• Security Latch

Fire Extinguisher
(Located along side of operator's seat)
-Typical View

Inspection and Replacement

Follow the manufacturer's recommendations on inspection and replacement.

SAFETY DECALS

Decals warning you of avoidable danger are located on various parts of the machine. They are there for your personal safety and protection. DO NOT remove them. They will fracture upon attempted removal and therefore, must be replaced.

Following are locations of important safety decals. Replace them if they are damaged or missing. All safety decals, instructional decals, or machine striping may be purchased through your local John Deere dealer.

To replace safety decals, ensure the installation area is clean and dry and decide on exact position before you remove the backing paper.

Safety Decal Locations

650175
(Located near the front left-hand side of cab)



650258
(Located on each side of cutter head assemblies)



CAUTION

SEVERING OF FINGERS OR HAND.
DO NOT PLACE FINGERS OR HAND NEAR A MOVING CUTTER BLADE, ATTEMPT TO STOP A MOVING CUTTER BLADE, OR PERFORM MAINTENANCE NEAR A MOVING CUTTER BLADE.

650259
(Located on mounting tube of each quad puller head assembly)



CAUTION

RISK OF INJURY FROM ROTATING TIRES. DO NOT PLACE FINGERS OR HAND NEAR MOVING QUAD PULLER TIRES, DISLodge A WEDGED OBJECT FROM MOVING TIRES, OR PERFORM MAINTENANCE NEAR MOVING TIRES.

650296
(Located near battery)

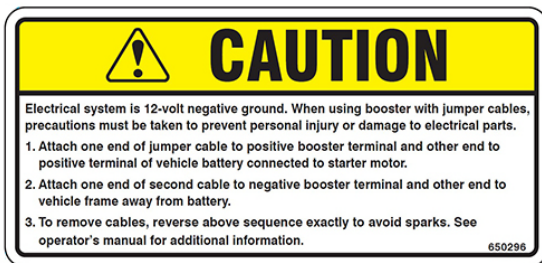

650303
(Located on right-hand cab window)

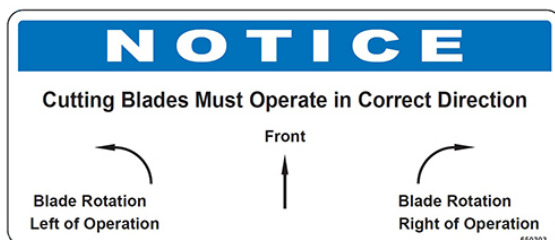

650379
(Located on right-hand cab window)

*** TO ENGAGE DETASSELING HEAD HYD MTRS:**

1. Reduce engine speed to an idle.
2. Clear area of unauthorized personnel.
3. Turn individual motor control switches to "ON".
4. Slowly increase engine RPM to desired speed.

650379

650347
(Located near engine on left-hand side of machine)

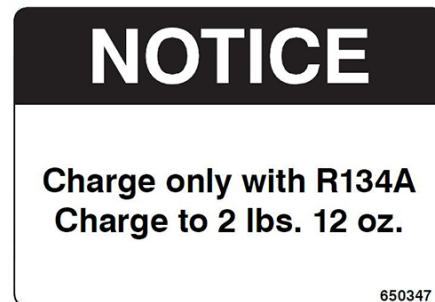

650364
(4) - Located on each air bag



**SECTION 2 –
SAFETY AND PRECAUTIONS**



650388
(Located near steering column)



650339
(Located near steering column)



650434
(Located near fan)

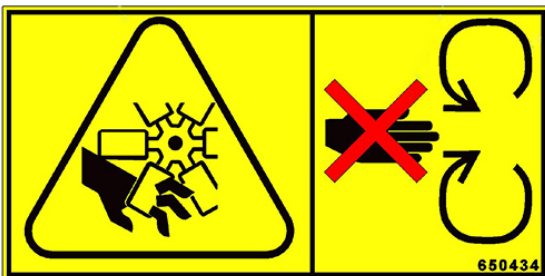

CAUTION
CUTTING/SEVERING OF FINGERS OR HAND.
DO NOT PLACE FINGERS OR HAND NEAR MOVING FAN BLADES.

650847
(Located beneath exterior rear left-hand cab window)



650849
(2) - Located on top of each fuel tank

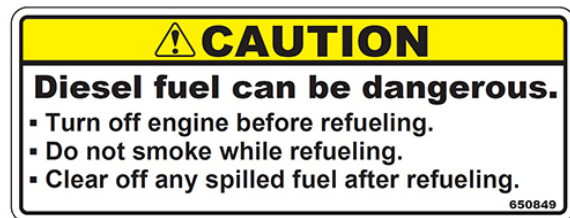

650954
(2) - Located on top of each fuel tank



650851
(2) - Located on each side of rear mainframe



**CE Supplement
(Export Machines)**

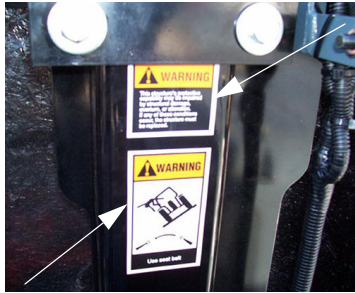

- Warns the operator to use seat belts.

- Warns of impairment to the structure's protective capabilities due to rollover, structural damage, or alteration. If any of these conditions should occur, the structure must be replaced.

650250

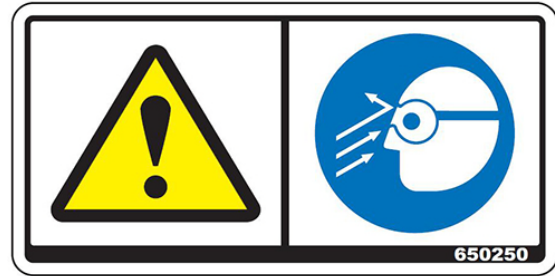

WEAR EYE PROTECTION

650251

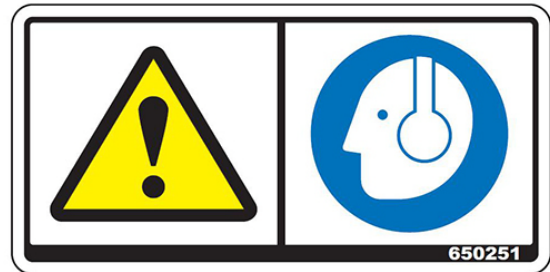

WEAR EAR PROTECTION

650248

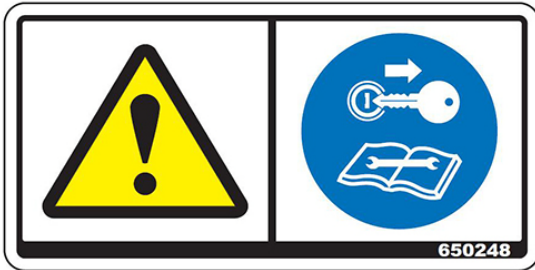

REMOVE KEY AND READ MAINTENANCE SECTION OF OPERATOR'S MANUAL

650252



ELECTRICAL LOCK-OUT

650249

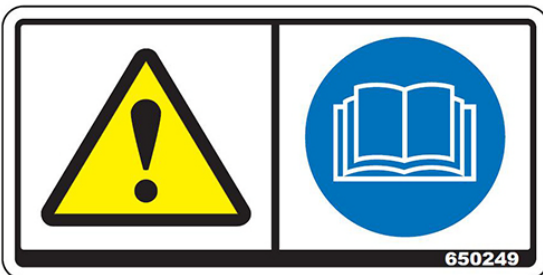

READ OPERATOR'S MANUAL

650253

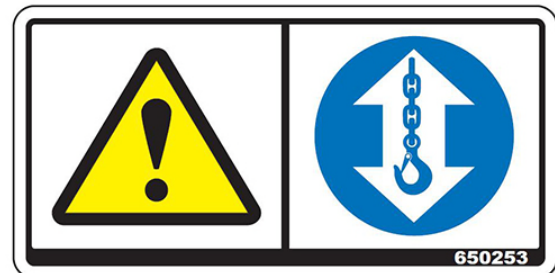

TOW POINT

**SECTION 2 –
SAFETY AND PRECAUTIONS**



650255

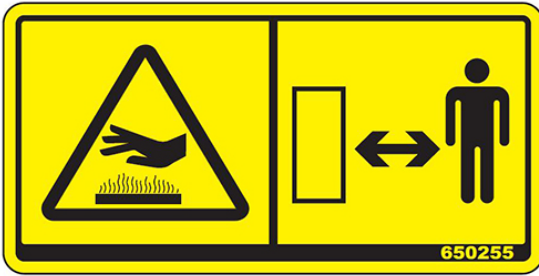

HOT SURFACE.
DO NOT TOUCH EXHAUST TUBE WHILE ENGINE IS RUNNING. ALLOW ADEQUATE TIME FOR THE ENGINE TO COOL DOWN BEFORE SERVICING.

650256



PRESSURIZED FLUID OR GAS.
KEEP SAFE DISTANCE AWAY FROM HAZARD.

650277

(4) - Located near each designated lifting point



LIFTING POINT



SECTION 3 – CAB

SEAT - OPERATOR

Fore-Aft Adjustment (1)

- Pull the Fore-Aft Lock Lever to the LEFT to unlock and adjust seat forward or rearward.
- Release the Fore-Aft Lock Lever to lock in position.



Ride Height (2)

- To adjust seat height, place full body weight on the seat and locate the Height Adjustment Dial. Rotate dial “clockwise” to lower seat height and “counter-clockwise” to raise seat height.

Ride Firmness (3)

- To adjust ride firmness, rotate the Ride Firmness Dial “clockwise” to “soften” ride, and “counter-clockwise” to “stiffen” ride.

Seat Belt

Refer to “Seat Belt” provided in the *Safety and Precautions Section* elsewhere in this manual for further information.

SEAT - OPERATOR (AIR SUSPENDED)

-If Equipped

Your machine may be equipped with an Air Suspended Operator’s Seat that is featured with the following for your driving and comfort needs.

NOTE: The ignition key must be in the ON position to activate the seat pump.



Ride Firmness (1)

- Pull the Ride Firmness Knob OUT to release air and “soften” ride.
- Push the Ride Firmness Knob IN to increase air and “stiffen” ride.

Fore-Aft Adjustment (2)

- Release Fore-Aft Lock Lever by pulling lever OUT.
- Slide forward or backward to desired position.
- Release lever to lock in position.

Height Adjustment (3)

- Release Height Lock Lever by pulling lever UP.
- Apply body weight slowly to lower seat position.
- Remove body weight slowly to raise seat position.
- When desired height is reached, release lever to lock in position.

Backrest Adjustment (4)

- Rotate the Backrest Knob “counter-clockwise” to tilt backrest forward or “clockwise” to tilt backrest backward.

Armrest Adjustment (5/6)

- Unzip either armrest to expose the armrest adjustment bolt.
- Turn bolt IN to raise armrest tilt or OUT to lower armrest tilt.

Seat Belt

Refer to “Seat Belt” provided in the *Safety and Precautions Section* elsewhere in this manual for further information.

OPERATOR’S STATION

Steering Column

The steering column may be adjusted for your driving comfort and ease of exiting and entering the operator’s station.

⚠ CAUTION

Ensure the steering wheel and steering column are in the locked position before attempting to operate the machine. Failure to comply may result in difficulty maintaining control of the machine.



-Typical View

Steering Column Adjustment

1. Push the Steering Column Tilt Lock Lever (located near center of steering column) in the DOWN position to release steering column.



Steering Column Tilt Lock Lever
(Located near center of steering column)

-Typical View

2. While maintaining the lock lever in the down position, PULL or PUSH the steering column to desired position.

3. Release the lock lever to re-lock the steering column into position.

Turn Signals

To Activate the Turn Signals

- Move the Turn Signal Switch (located on the side console) to the LEFT (for a left-hand turn), or RIGHT (for a right-hand turn).

NOTE: The Turn Signal Switch will illuminate when activated in either direction.

NOTE: The Turn Signal Switch is not self-centering and must be manually returned to the OFF (mid) position after turn is complete.



Turn Signal Switch
(Located on the side console)
-Typical View

Hazard/Warning Lights

The Hazard/Warning Lights (located on the front and rear of machine) are to be used at any time, day or night, when traveling on a public roadway, unless prohibited by law.

- Press the Hazard/Warning Lights Switch (located on the side console) in the UP position to turn ON.
- Press the Hazard/Warning Lights Switch in the DOWN position to turn OFF.



Hazard/Warning Lights Switch
(Located on the side console)
-Typical View

Highway Running Lights

The Highway Running Lights (located on each side of operator's station) are used when traveling on a public roadway and are activated by operating the headlights.



Highway Running Lights
(Located on each side
of operator's station)
-Typical View

NOTE: The ignition does NOT have to be on to operate the Highway Running Lights. However, prolonged use of these lights without the engine running is not recommended.

Headlights/Work Lights

The Headlights (located on the front of operator's station) are to be used at any time, day or night, when traveling on a public roadway.

NOTE: The ignition does NOT have to be on to operate the Headlights. However, prolonged use of these lights without the engine running is not recommended.

The Work Lights (located on the front and rear of operator's station) are for use when operating in the field after dark.

NOTE: The ignition must be in the ON position to operate the Work Lights.

NOTE: Turn the Work Lights OFF before entering a public roadway.



Headlights/Work Lights
-Typical View

- Press the Lights Switch (located on the side console) in the MID position to activate the Headlights.
- Press the Lights Switch in the UP position to activate the Headlights and Work Lights.
- Press the Lights Switch in the DOWN position to turn all lights OFF.



Lights Switch
(Located on the side console)
-Typical View

Emergency Stop (E-Stop)

The E-Stop Switch (located near the side console) provides a quick and positive method for stopping the engine in an emergency situation.

NOTE: DO NOT use the E-Stop for non-emergency stopping or as a parking brake.



E-Stop Switch
(Located near the side console)
-Typical View

Refer to the *Safety and Precautions Section* elsewhere in this manual for further information.

Horn

The Horn is sounded by pressing the Horn Button (located on the side console).



Horn Button
(Located on the side console)
-Typical View

Throttle Switch

The Throttle Switch (located on the side console) is used to control engine speed (RPM).



Throttle Switch
(Located on the side console)
-Typical View

NOTE: Engine speed can range between 1000 and 2600-2800 RPM.

The Throttle Switch works with a timer to tell the engine how fast to run. The longer the operator holds the switch in either direction (press UP/“rabbit icon” to increase speed,

press DOWN/“turtle icon” to decrease speed), the more the engine will speed up or slow down.

Refer to “Hydrostatic Drive” provided in the *Engine and Drive Systems Section* elsewhere in this manual for further information.

Traction Valve Switch

NOTICE

Do not operate the front traction valve for an extended period of time.

The Traction Valve Switch (located near the front of operator’s station) is used to enable the front traction valve.

NOTE: When the Traction Valve Switch is on, a Traction Valve Indicator (located on the side console) will illuminate.



Traction Valve Switch - Front
(Located near the front of operator’s station)
-Typical View



Traction Valve Indicator
(Located on the side console)
-Typical View

Refer to “Hydrostatic Drive” provided in the *Engine and Drive Systems Section* elsewhere in this manual for further information.

Depth Command Switches

-If Equipped

The Depth Command Switches (located near the front of operator’s station) allow the operator to adjust the LS System cutting or pulling height from the operator’s seat.

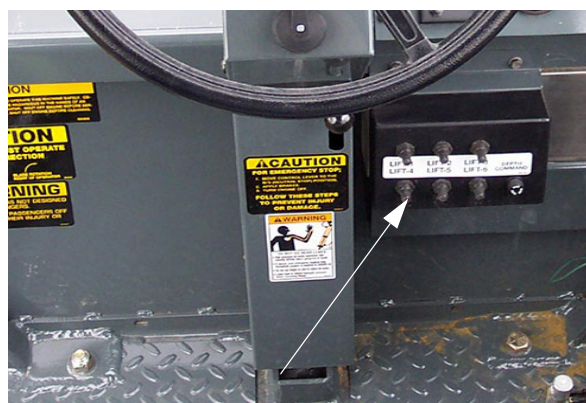

Depth Command Switches
(Located near the front of operator’s station)
-Typical View

Refer to the *Detasseling Systems Section* elsewhere in this manual for further information.

Hydrostatic Drive Control Handle

The Hydrostatic Drive Control Handle (located on the side console) is used to control the direction of the machine and the speed in which it travels. It also controls the all up/down functions of the lifts.



Hydrostatic Drive Control Handle
(Located on the side console)
-Typical View

Refer to “Hydrostatic Drive” provided in the *Engine and Drive Systems Section* elsewhere in this manual for further information.

Parking Brake Switch

⚠ CAUTION

Do not engage the parking brake while the machine is moving. Failure to comply may result in personal injury and machine damage.

NOTICE

The parking brake is not intended for normal or emergency stopping.

NOTICE

Do not operate the machine at idle speed while the parking brake is engaged. Failure to comply may result in brake damage.

The Parking Brake will engage when applied hydraulic pressure falls below 250 PSI (17.2 bar), or if the engine is shut off.

NOTE: Bring the machine to a complete stop before engaging the Parking Brake.

To Engage the Parking Brake

- Move the Hydrostatic Drive Control Handle to the NEUTRAL position.
- Lift the red switch cover (located on the side console).

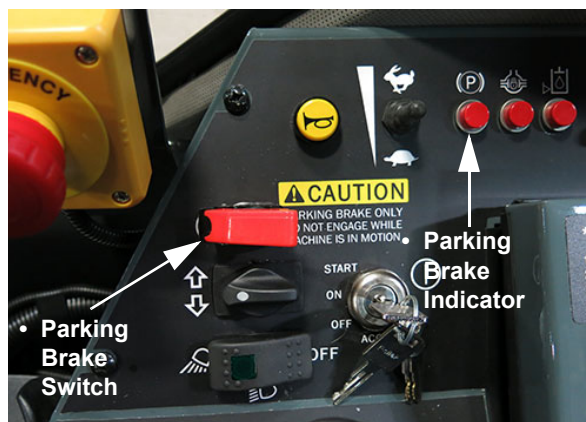

Parking Brake Switch/Indicator
(Located on the side console)
-Typical View

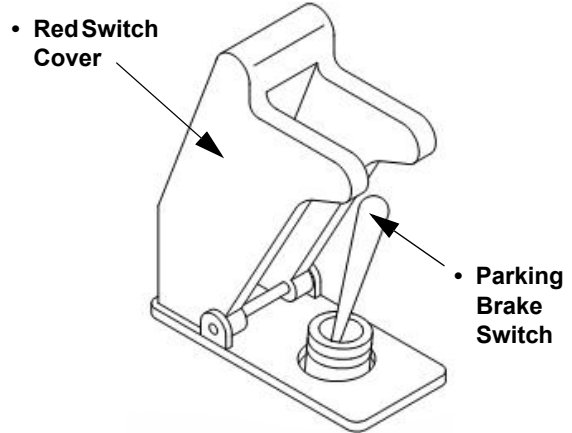

- Press the Parking Brake Switch in the UP position to engage brake.

NOTE: When the Parking Brake is ENGAGED, a Parking Brake Indicator (located on the side console) will illuminate.

To Disengage the Parking Brake

- Close the red switch cover, which will move the Parking Brake Switch to the DOWN (Off) position.

Engine Monitor

NOTICE

Immediately reduce engine speed and shut ignition off if any red indicator lights appear on the engine monitor. Determine cause and correct issue before continuing operation.

The Engine Monitor (located near the front of operator's station) monitors engine parameters.



Engine Monitor
(Located near the front of operator's station)
-Typical View

Refer to “Engine Monitor” provided in the *Engine and Drive Systems Section* elsewhere in this manual, as well as the manufacturer’s operation manual for complete operating instructions and programming information.

Tasselrol®/LS System 12™ Control Panel

The Tasselrol/LS System 12 Control Panel (located on the side console - lift cover to access) is used for programming the detasseling heads.



Tasselrol/LS System 12 Control Panel
(Located on the side console
- lift cover to access)
-Typical View

Refer to the *Detasseling Systems Section* elsewhere in this manual for further information.

Master Detasseler Switch

The detasseling head motors are controlled by the Master Detasseler Switch (located on the side console). This switch must be in the ON position to enable detasseling head operation.



Master Detasseler Switch
(Located on the side console)
-Typical View

Refer to the *Detasseling Systems Section* elsewhere in this manual for further information.

Detasseling Head Motor Control Switches

*** TO ENGAGE DETASSELING HEAD HYD MTRS:**

1. Reduce engine speed to an idle.
2. Clear area of unauthorized personnel.
3. Turn individual motor control switches to “ON”.
4. Slowly increase engine RPM to desired speed.

650379

The Detasseling Head Motor Control Switches (located on the side console) activate the detasseling head motors (Lifts 1-6).



Detasseling Head Motor Control Switches
(Located on the side console)
-Typical View

Refer to the *Detasseling Systems Section* elsewhere in this manual for further information.

Fuel Tank Selector Switch

The Fuel Tank Selector Switch (located on the side console) is used to select which of the two fuel tanks that you want to draw fuel from.

- **To draw fuel from the right-hand fuel tank**, press the Fuel Tank Selector Switch in the UP (Right) position.
- **To draw fuel from the left-hand fuel tank**, press the Fuel Tank Selector Switch in the DOWN (Left) position.



Fuel Tank Selector Switch
(Located on the side console)
-Typical View

Fuel Gauge

The Fuel Gauge (located near the front of operator's station) measures the amount of fuel in either fuel tank, depending on the tank selected.

NOTE: A low fuel indicator light will illuminate when fuel level in either tank reaches a low level. When this indicator light is on, you must either draw fuel from the opposite tank, or refuel.



Fuel Gauge
(Located near the front of operator's station)
-Typical View

Windshield Wiper

-If Equipped

- **To turn the Windshield Wiper on**, press the Wiper Switch (located on the side console) in the UP (On) position.
- **To turn the Windshield Wiper off**, press the Wiper Switch in the DOWN (Off) position.

NOTE: The Windshield Wiper will continue to operate until the switch is returned to the OFF position.



Wiper Switch
(Located on the side console)
-Typical View

Gear Selector Switch

The wheel motors on your machine are controlled by the Gear Selector Switch (located on the side console).



Gear Selector Switch
(Located on the side console)
-Typical View

Refer to “Hydrostatic Drive” provided in the *Engine and Drive Systems Section* elsewhere in this manual for further information.

Hydraulic Outrigger Fold Switches

-If Equipped

The Hydraulic Outrigger Fold Switches (located on the side console) are used to hydraulically unfold/fold the outriggers.



Hydraulic Outrigger Fold Switches
(Located on the side console)
-Typical View

Refer to “Transporting” provided in the *Miscellaneous Section* elsewhere in this manual for further information.

Climate Controls

-If Equipped

The Climate Controls are located on the cab headliner.

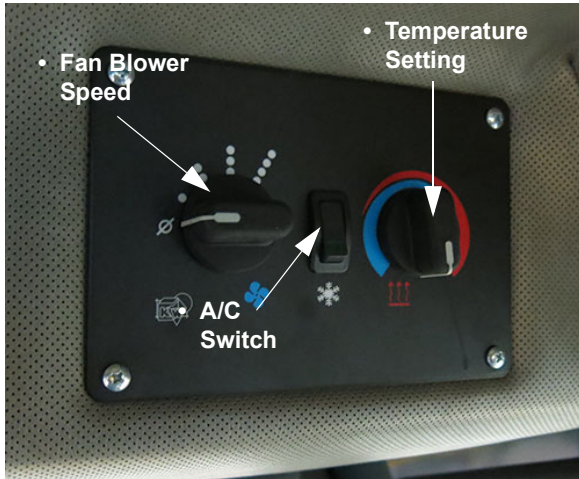

Climate Controls
(Located on cab headliner)
-Typical View



Air Vent
-Typical View

Fan Blower Speed

- Rotate the Fan Blower Speed Dial “clockwise” to increase fan speed.
- Rotate the Fan Blower Speed Dial “counter-clockwise” to decrease fan speed.
- Rotate the Fan Blower Speed Dial fully “counter-clockwise” to turn OFF.

Temperature Setting

- Rotate the Temperature Setting Dial “clockwise” to increase temperature.
- Rotate the Temperature Setting Dial “counter-clockwise” to decrease temperature.

Air Conditioner Switch

- To activate the air conditioner, press the Air Conditioner Switch in the UP (On) position.
- Adjust fan speed and temperature accordingly.

Air Vents

Rotate Air Vents to desired position, or individually turn on or off with the directional fins.

Refer to the *Maintenance and Storage Section* elsewhere in this manual for information on servicing the Air Conditioning System.

Stereo/Radio

-If Equipped

The cab is featured with an AM/FM/Tuner with a CD Player and Weatherband Broadcasting. Refer to the stereo manufacturer’s user guide for complete operating instructions and programming information.



Stereo/Radio
(Located on cab headliner)
-Typical View

Interior Work Light

-If Equipped

An Interior Work Light (located on the cab headliner) is provided for your convenience.

- Press the Interior Work Light Switch in the UP position to turn light on. Press switch in the DOWN position to turn light off.

NOTE: The ignition key must be in the ON position to operate the light.



Interior Work Light
(Located on cab headliner)
-Typical View



SECTION 4 – ENGINE AND DRIVE SYSTEMS

ENGINE - STARTING

Starting the Engine

WARNING

DO NOT USE ETHER!

The engine is equipped with an electronic starting aid. Use of ether may cause an explosion and severe injury.

CAUTION

Start engine from the operator's seat only. When running engine inside a building, ensure there is adequate ventilation.

CAUTION

Electrical system is 12-volt negative ground. When using booster with jumper cables, precautions must be taken to prevent personal injury or damage to electrical parts.

1. Attach one end of jumper cable to positive booster terminal and other end to positive terminal of vehicle battery connected to starter motor.
2. Attach one end of second cable to negative booster terminal and other end to vehicle frame away from battery.
3. To remove cables, reverse above sequence exactly to avoid sparks. See operator's manual for additional information.

NOTICE

Do not use starting fluid when starting the engine. Use of too much starting fluid will result in engine damage.

Pre-Operational Checklist

1. Check engine oil level.

NOTE: Do not operate the machine when oil level is below the "L" (low) mark or above the "H" (high) mark on the engine oil dipstick.

2. Check coolant level.
3. Check hydraulic reservoir oil level.
4. Check cooling air intake screen.
5. Drain fuel/water separator.
6. Check engine drive belt.
7. Check Filter Minder®.
8. Check for any oil or fuel leaks.

Cold Start Procedure

1. Move the Hydrostatic Drive Control Handle to the NEUTRAL position.
2. Engage the parking brake.
3. Turn the ignition to the ON position.
4. Engage the starter.

(If the engine fails to start after 15 seconds, turn the key OFF, wait one minute, and repeat the procedure. If the engine fails to start after three attempts, check the fuel supply system).

NOTE: Absence of blue or white exhaust smoke while cranking indicates that no fuel is being delivered.

5. After the engine is started, immediately reduce the throttle speed to 1/3.
6. Observe indicator lights and gauges (after start-up).

NOTE: If any functions do not operate, shut the engine OFF and determine cause.

SECTION 4 – ENGINE AND DRIVE SYSTEMS



7. Allow a warm-up period of at least five (5) minutes before operating the engine at a high RPM.

NOTE: The engine must reach operating temperature and oil pressure must stabilize in the normal operating range before it is run faster than an idle speed (1000 RPM or less). Cold oil may not flow in quantities to adequately prevent pump seizure. A longer warm-up period may be required in cold weather.

8. Disengage the parking brake.

Jump Starting

1. Engage the parking brake.
2. Rotate the Battery Disconnect Switch (located on the rear mainframe) to the ON position.

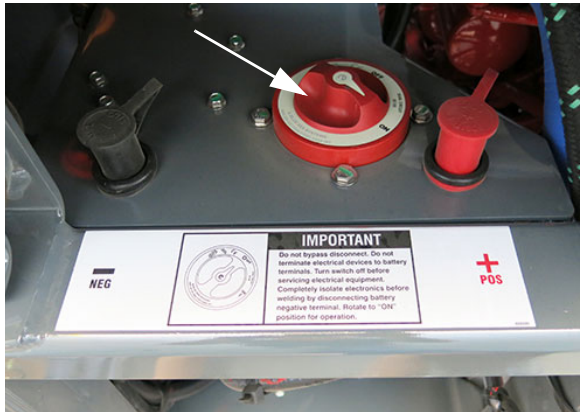

Battery Disconnect Switch
(Located on the rear mainframe)
-Typical View

3. Connect cables from charging device (i.e. battery charger or another machine) to the battery terminals - positive cable to the positive terminal, and negative cable to the negative terminal.
4. Allow batteries to charge approximately 5-10 minutes.

NOTICE

Do not over-crank the starter. Failure to comply may result in starter damage.

5. Engage the starter by starting the machine.
6. Remove the charging cables in reverse to the way you attached them (negative cable first, then positive cable).

NOTE: Ensure that the charging cables do not touch together or to any metal surface.

7. Allow engine to idle for approximately 5 minutes to recharge the batteries.

NOTE: Longer idle time may be required, depending on how depleted the batteries are.

ENGINE MONITOR

NOTICE

Immediately reduce engine speed and shut ignition off if any red indicator lights appear on the engine monitor. Determine cause and correct issue before continuing operation.

Your machine is featured with an engine monitoring system, which monitors engine parameters. Refer to the manufacturer's operation manual for complete operating and programming instructions.



Engine Monitor Display
(Located near the front of operator’s station)
-Typical View

NOTE: The Engine Monitor is factory pre-set. No adjustments are required.

The Engine Monitor Display is featured with five soft keys that allow the operator to select desired engine/transmission data and display it in analog gauges or digital values, as well as display active/current alarm messages.

NOTE: If parameter is not available from the engine/transmission, the Engine Monitor will not be allowed to select it. If a certain parameter becomes unavailable while in view, “- - -” will be displayed.

Quad Analog Gauge Screen (F1)

Press the F1 Button to navigate to the Quad Analog Gauge screen, which displays up to four (4) current engine parameters. The display is featured with configurable data, so up to 16 gauges may be selected.



Quad Analog Gauge Screen
-Typical View

Quad Analog Data Selection

To adjust the contents of the quad analog screen, press any of the first four soft keys to display the Button Bar, then press F5 to enable cycling through all of the display parameters.

Quad Digital Data Screen (F2)

Press the F2 Button to navigate to the Quad Digital Data screen, which like the Quad Analog Gauge screen, displays up to four (4) current engine parameters.



Quad Digital Data Screen
-Typical View

Quad Digital Data Selection

To adjust the contents of the quad digital screen, press any of the first four soft keys to display the Button Bar, then press F5 to enable cycling through all of the display parameters.

Single Analog Gauge Screen (F3)

Press the F3 Button to navigate to the Single Analog Gauge screen. The configurable data is also accompanied by a digital readout below.



Single Analog Gauge Screen
-Typical View

Single Analog Data Selection

To adjust the contents of the single analog screen, press F3 to display the Button Bar, then press F3 again to enable cycling through all of the display parameters.

Active Alarm Screen (F4)

Press the F4 Button to navigate to the Active Alarm screen, which displays all active/current alarms received by the system.

NOTE: The alarms are displayed by the most current. Press the F1 and F2 Buttons to scroll through the alarms.



Active Alarm Screen
-Typical View

NOTE: Active/current alarm messages are automatically cleared from the list when the fault is no longer received by the Engine Monitor.

When an active/current alarm is received, a flashing Active Fault Warning will appear on the display describing details of the alarm.

NOTE: The alarm list is accessed by pressing any key while an Active Fault Warning is displayed.

Press the F3 Button to acknowledge alarm. Alarms not yet acknowledged are displayed with a red background. Alarms that have been acknowledged are displayed with a black background.



Active Fault Warning
-Typical View

**Configuration/Menu
Screens (F5)**

Press and hold the F5 Button to navigate to the Configuration/Menu Screens (Settings, Units, Language, Display, Service, etc.)

NOTE: Pressing the F5 Button while in any of the menu screens will revert you back to the previous menu.



Menu Screen
-Typical View

Button Bar

Press any of the first four soft keys to display the context-dependent Button Bar. The top level Button Bar shows the basic structure of the monitor and will disappear after five (5) seconds of inactivity.

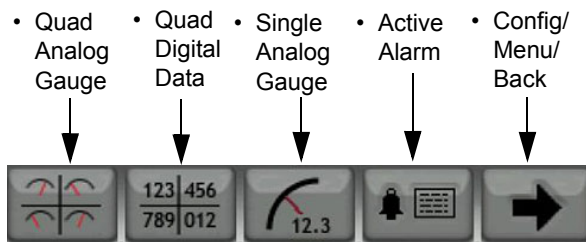

Button Bar
-Typical View

HYDROSTATIC DRIVE

The Hydrostatic Drive system uses pressurized hydraulic fluid to drive the machine, which is derived from the diesel

engine. The hydrostatic power system consists of a heavy duty hydrostatic variable displacement pump and variable displacement wheel motors. A manual control lever (connected to the pump swashplate) controls the amount of and direction of oil flow to the motors, determining the speed and direction of the machine.

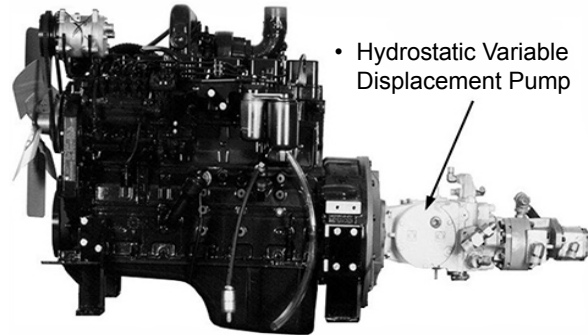

NOTICE

Never operate the detasseler less than full recommended throttle.

NOTICE

Cold oil may not flow in quantities adequate to prevent pump cavitation.

Hydrostatic Drive Components

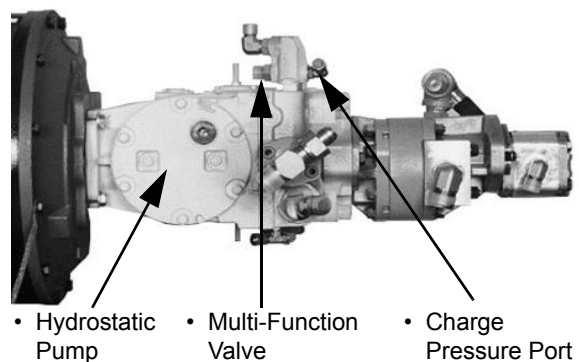

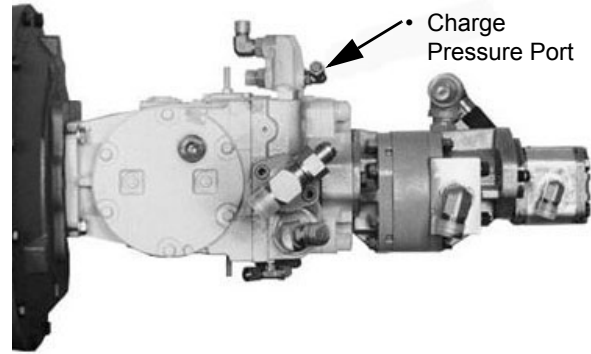
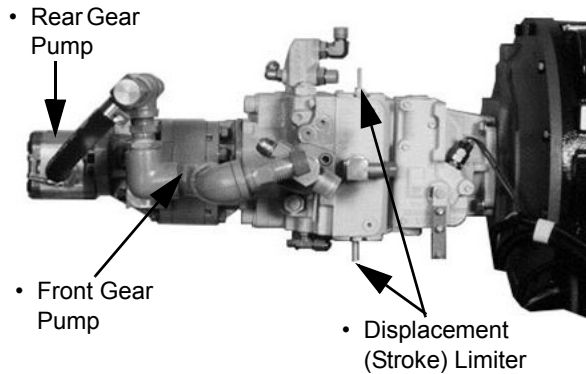

NOTE: Charge Pressure should range between 348 and 365 psi (24 and 25 bar). If below required pressure, contact your John Deere dealer for assistance.

Multi-Function Valves

The hydrostatic pump is equipped with two (2) Multi-Function Valves. These valves incorporate the system check valve, pressure limiter valve, high-pressure relief valve, and bypass valve.

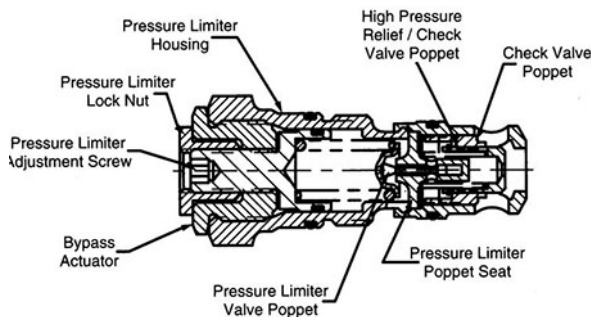

Cross Section of Multi-Function Valve

When the preset pressure is reached, the pressure limiter system acts to rapidly de-stroke the pump in order to limit system pressure.

Charge Pressure

To monitor the closed loop system (hydrostatic pump):

- Install a 500 psi (34.5 bar) pressure gauge at the Charge Pressure Port.
- Start the engine.
- Open throttle to full RPM.

Displacement Limiter

The hydrostatic pump is equipped with a mechanical Displacement (Stroke) Limiter.

NOTICE

The Displacement Limiter has been factory set and requires no further adjustment. If adjustments are made without contacting your John Deere dealer, system damage may result and will void the warranty.

Loop Flushing Valve

NOTICE

The Loop Flushing Valve has been factory set and requires no further adjustment. If adjustments are made without contacting your John Deere dealer, system damage may result and will void the warranty.

The hydrostatic pump is equipped with a Loop Flushing Valve (located beneath machine - remove screen to access), which

is used to remove fluid from the hydrostatic system for cooling and contamination removal.

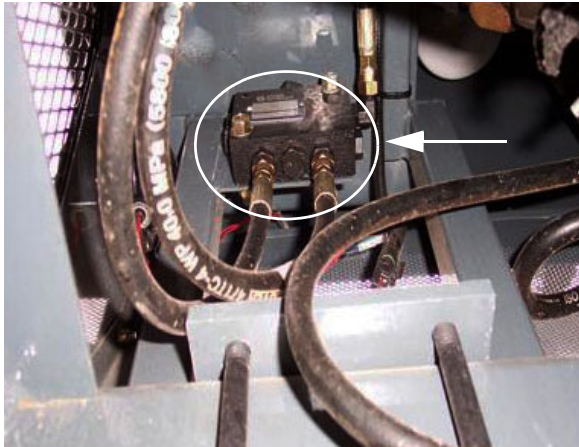

Loop Flushing Valve
(Located beneath machine -
remove screen -
remove screen to access)
-Typical View

Traction Valves

NOTICE

To prevent hydraulic loop damage, do not operate the front traction valve continuously, or while traveling over 4 mph (6.4 km/h). Activate the front traction valve only when needed. Shut the Traction Valve Switch OFF when clear of the problem area.

Your machine is equipped with hydraulic valves for increased traction (one located in the front hydraulic loop, and one in the rear hydraulic loop). These valves reduce spin-out if muddy conditions prevail, or if wheels lose traction for any reason.

The Traction Valve in the rear loop is active at all times. The Traction Valve in the front loop is activated by the Traction Valve Switch (located near the front of the operator's station) and should only be used when needed.

To Activate the Front Traction Valve

- Press the Traction Valve Switch IN to turn traction control on. Press switch again to turn off.

NOTE: When the Traction Valve Switch is on, a Traction Valve Indicator (located on the side console) will illuminate.

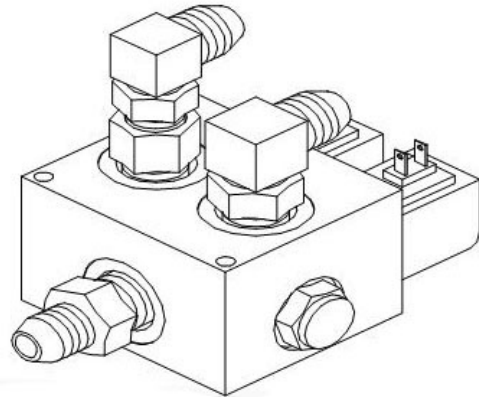

Traction Valve
-Typical View



Traction Valve Switch - Front
(Located near the front of operator's station)
-Typical View



Traction Valve Indicator
(Located on the side console)
-Typical View

Wheel Motors

The variable speed Wheel Motors on your machine are controlled by the Gear Selector Switch (located on the side console). You may choose to operate in second (high) gear (which gives you a higher speed for better road performance), or first (low) gear (which gives you a lower speed for better field performance).

- Press the Gear Selector Switch in the UP position to operate in second (high) gear.
- Press the Gear Selector Switch in the DOWN position to operate in first (low) gear.



Gear Selector Switch
(Located on the side console)
-Typical View

Throttle Switch

The Throttle Switch (located on the side console) is used to control engine speed (RPM).

NOTE: Engine speed can range between 1000 and 2600-2800 RPM.



Throttle Switch
(Located on the side console)
-Typical View

The Throttle Switch works with a timer to tell the engine how fast to run. The longer the operator holds the switch in either direction (press UP/"rabbit icon" to increase speed,

press DOWN/“turtle icon” to decrease speed), the more the engine will speed up or slow down.

Drive System Control

- Slowly open throttle to the maximum recommended engine RPM (2600-2800 RPM).
- **To move the machine forward**, slowly push the Hydrostatic Drive Control Handle FORWARD.

NOTE: The further the handle is moved forward, the faster the machine will travel and the engine speed will increase.



Hydrostatic Drive Control Handle
(Located on the side console)
-Typical View

- **To move the machine in reverse**, slowly pull the Hydrostatic Drive Control Handle backward.

NOTE: The farther back the handle is pulled, the faster the machine's speed.

- **To stop the machine**, slowly place the Hydrostatic Drive Control Handle in the NEUTRAL position.

NOTE: Before turning the engine off, reduce the engine speed and allow to idle for a minimum of three (3) minutes.

SECTION 5 – HYDRAULIC SYSTEMS

HYDRAULIC SYSTEM



The auxiliary Hydraulic System is an open-type and is mounted behind the heavy-duty hydrostatic variable displacement pump. This system consists of dual gear pumps (that supply required hydraulics to operate the full-time power steering, lift cylinders, cutter heads, and quad pullers).

After supplying each of these systems, the hydraulic oil is sent to the oil cooler (located in front of the engine coolant radiator), where it is then cooled and sent back to the hydraulic oil reservoir.

Low Hydraulic Oil Indicator

A Low Hydraulic Oil Indicator (located on the side console) will illuminate when hydraulic oil level drops too low for safe operation. If this indicator light illuminates, shut down the engine and refill hydraulic oil reservoir to satisfactory level.

NOTE: A damaged wire or circuit may cause the Low Hydraulic Oil Indicator to falsely illuminate.



Low Hydraulic Oil Indicator
(Located on the side console)
-Typical View

Gear Pump

The front (larger) Gear Pump supplies hydraulic power to the cutter heads and quad pullers. The rear (smaller) Gear Pump supplies hydraulic power to the power steering and lift cylinders.

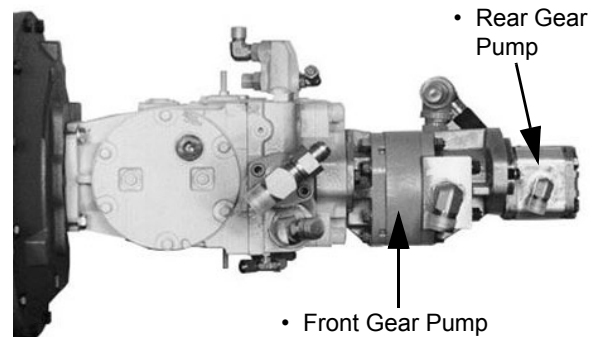

Power Steering

The full-time Power Steering system consists of a hydraulic steering motor (mounted on the end of the steering wheel shaft), which is connected to a pair of double-action steering cylinders (mounted on both of the front steering arms and outer leg weldments).



Steering Cylinders
(Located on both of the front steering arms and outer leg weldments)
-Typical View

This system is powered by the rear gear pump (driven by the engine). Since gear pumps are sensitive to engine RPM, it is best to operate the detasseler at full recommended throttle to ensure maximum steering responsiveness.

NOTE: The higher the engine RPM, the higher the oil flow.

Lift Cylinders

The Lift Cylinders (located on each lift unit) adjust the height of the detasseling head assemblies, which are controlled by the Tasselrol®/LS System 12™ Control Panel (located on the side console).

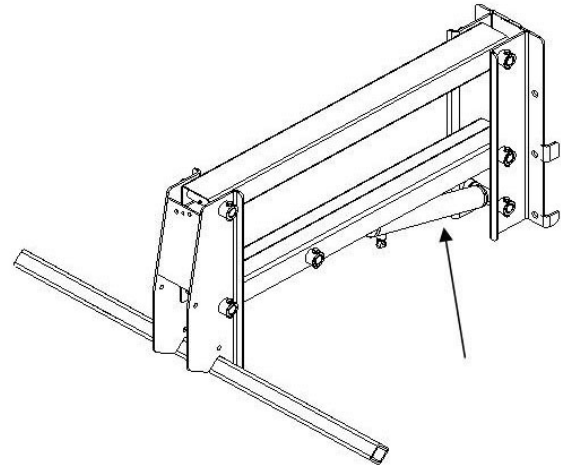

Lift Cylinders
(Located on each lift unit)
-Typical View



Tasselrol/LS System 12 Control Panel
(Located on the side console
- lift cover to access)
-Typical View

Refer to “Tasselrol/LS System 12” provided in the *Detasseling Systems Section* elsewhere in this manual for information on operating and adjusting parameters.

Electro-Hydraulic Valves

The Electro-Hydraulic Valves (located on the front of tool bar) control the lift cylinders in their upward and downward movement.



Electro-Hydraulic Valves
(Located on the front of tool bar)
-Typical View

Dump Valve

The Dump Valve (located beneath the operator's seat) is the main valve, which controls the amount of pressure going to the lift valve.

NOTE: The Dump Valve is factory pre-set to 2200 psi (151.7 bar).

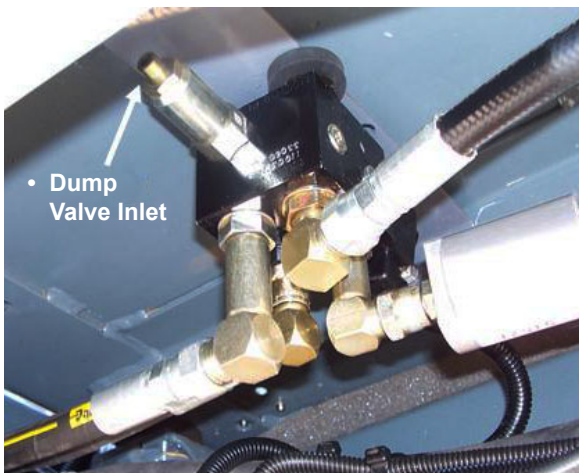

Dump Valve
(Located beneath operator's seat)
-Typical View

NOTE: To check Dump Valve psi/bar, install a 3000 psi (206.8 bar) pressure gauge on the Dump Valve Inlet. If

additional adjustment is required, contact your John Deere dealer for assistance.

Detasseling Heads

*** TO ENGAGE DETASSELING HEAD HYD MTRS:**

1. Reduce engine speed to an idle.
2. Clear area of unauthorized personnel.
3. Turn individual motor control switches to "ON".
4. Slowly increase engine RPM to desired speed.

650379

The hydraulic motors on the detasseling heads are controlled by the Master Detasseler Switch and are individually turned on/off using the Detasseling Head Motor Control Switches (located on the side console).

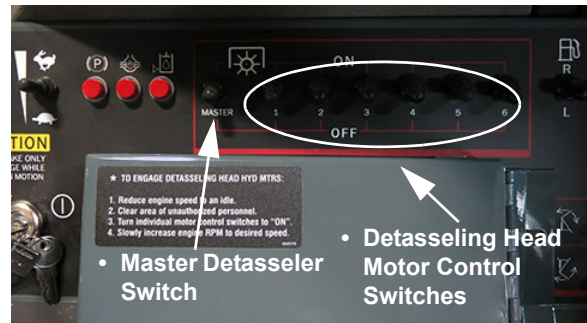

Master Detasseler and Detasseling Head Motor Control Switches
(Located on the side console)
-Typical View

Motor Control Valves

- To open the solenoid on the Motor Control Valve(s) (which activate the motors), press the corresponding Detasseling Head Motor Control Switch(es) (located on the side console) in the ON (Up) position.
- Press Detasseling Head Motor Control Switch(es) in the OFF (Down) position to turn motors off.

NOTE: Activate hydraulic motors while engine speed is at idle, then increase engine RPM to operating speed.

Adjustable Needle Valve

Each set of motors is controlled by an Adjustable Needle Valve that restricts hydraulic flow to the hydraulic motors, ensuring they do not over-speed and become damaged.

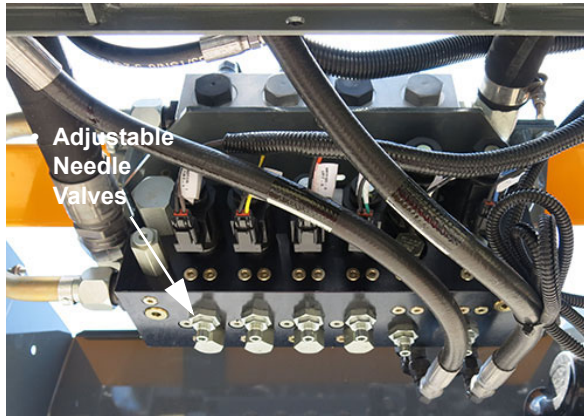

Motor Control Valves
-Typical View

NOTE: The Adjustable Needle Valve is factory pre-set and requires no adjustment.



SECTION 6 – ELECTRICAL SYSTEMS

BATTERIES

⚠ WARNING

Battery posts, terminals, and related accessories contain lead and lead compounds, chemicals known to the State of California to cause cancer and reproductive harm. Wash hands after handling.

⚠ CAUTION

Batteries contain sulfuric acid. Avoid contact with skin, eyes, or clothing. Do not inhale fumes or ingest liquid. Batteries contain gases which can explode. Keep sparks and flame away while servicing.

⚠ CAUTION

Disconnect the battery when servicing any part of the electrical system. Failure to comply may result in injury and property damage.

NOTICE

Use a sturdy stationary ladder to safely access/service the battery.

Access

The battery is located near the rear right-hand side of machine. Open hood panel to access.

NOTE: When servicing the electrical system, always remove the battery (removing the ground cable first). When reinstalling the battery, connect the ground cable last.



Battery Access

(Located near rear right-hand side of machine - open hood panel to access)
-Typical View

Charging

⚠ CAUTION

Electrical system is 12-volt negative ground. When using booster with jumper cables, precautions must be taken to prevent personal injury or damage to electrical parts.

1. Attach one end of jumper cable to positive booster terminal and other end to positive terminal of vehicle battery connected to starter motor.
2. Attach one end of second cable to negative booster terminal and other end to vehicle frame away from battery.
3. To remove cables, reverse above sequence exactly to avoid sparks. See operator's manual for additional information.

Connect charging cables to the battery - positive cable to the positive terminal, and negative cable to the negative terminal.

NOTICE

To ensure sufficient electrical contact, battery terminal connections should be as clean and tight as possible.

Cleaning

- Disconnect the battery cables from battery.
- Remove any corrosion with a wire brush or battery post brush.
- Wash the battery cable connections and posts with a mild baking soda and ammonia solution.
- Apply grease (or dielectric grease) to prevent corrosion.
- Reconnect the batteries, ensuring connections are tight.
- Clean every 100 hours of operation.

Replacement

Install replacement batteries with ratings equivalent to the following specifications:

- **Voltage** - 12V only
- **CCA** - 30 seconds at 0° F. (950)
- **Reserve Capacity** - 185 minutes at 25 amps

Storage

Refer to “Storage” provided in the *Maintenance and Storage Section* elsewhere in this manual for further information.

BATTERY DISCONNECT SWITCH

WARNING

Do not bypass disconnect. Do not terminate electrical devices to battery terminals. Turn Battery Disconnect Switch OFF before servicing electrical equipment. Completely isolate electronics before welding by disconnecting negative battery terminal. Failure to comply may result in serious injury or equipment damage.

WARNING

DO NOT use the Battery Disconnect Switch as a safety device when performing work to the electrical system. Disconnect the negative battery cable before servicing.

Your machine is equipped with a Battery Disconnect Switch (located on the rear mainframe) to de-energize battery power, cutting all electrical power to the engine.

NOTE: Ensure the Battery Disconnect Switch is in the ON position before starting the engine.

- Rotate the Battery Disconnect Switch to the ON (clockwise) or OFF (counter-clockwise) positions to operate.

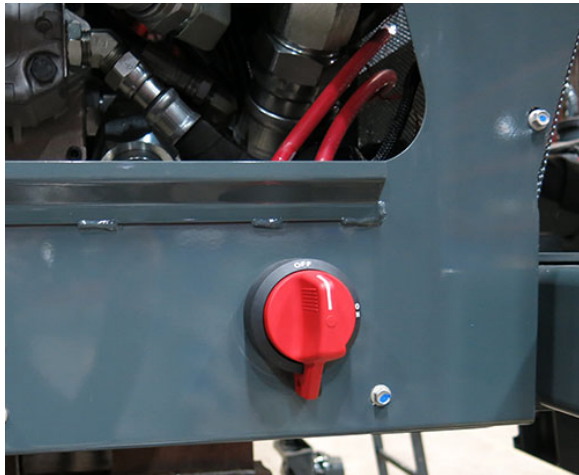

Battery Disconnect Switch
(Located on the rear mainframe)
-Typical View

NOTE: Turn the Battery Disconnect Switch OFF during long storage periods.

FUSES AND RELAYS

NOTE: Ensure replacement fuses are of equal size and amperage.

Fuse/Relay Access

The Fuse/Relay Box is located near the floor beneath the side console.

- Rotate the Fuse/Relay Box cover latch in the “counter-clockwise” position and remove cover.

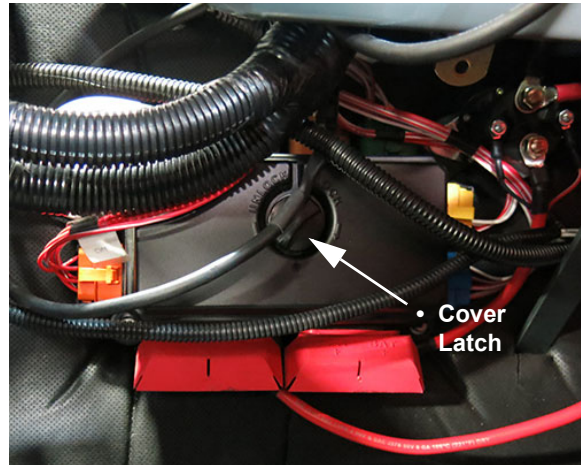

Fuse/Relay Box
(Located near floor beneath side console)
-Typical View

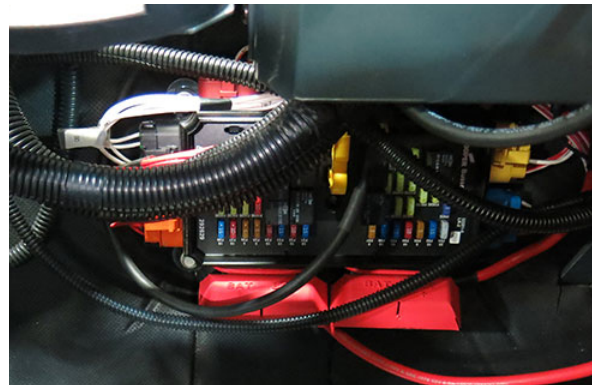

Fuse/Relay Box
(Cover Removed)
-Typical View

The following label is affixed under the fuse/relay cover and provides information on fuse/relay amperage ratings.

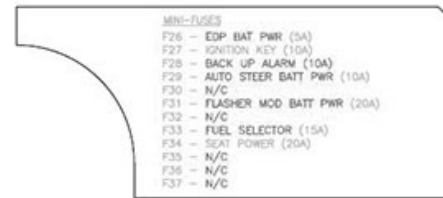

Depth Command Fuse -If Equipped

NOTICE

Do not operate more than two (2) actuators at one time. Failure to comply may result in blowing the depth command fuse.

The Depth Command Fuse is located on the Depth Command Switch Panel (located near the front of operator's station).

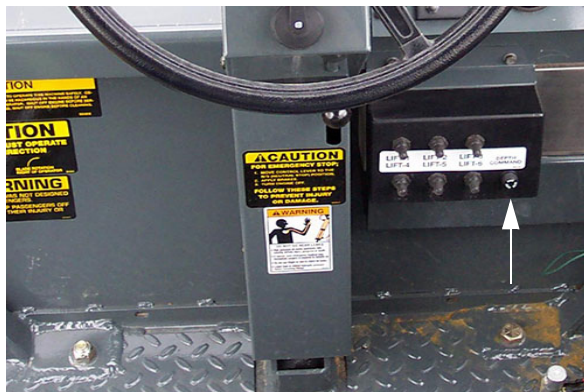

Depth Command Fuse
(Located on the Depth Command Switch Panel near front of operator's station)
-Typical View

NOTE: A blown fuse may indicate that the LS/Depth Command Pivot Bolts (as shown in the following illustration) are torqued too tight. If the fuse continues to blow, determine the cause and correct. Contact your John Deere dealer if additional assistance is needed.

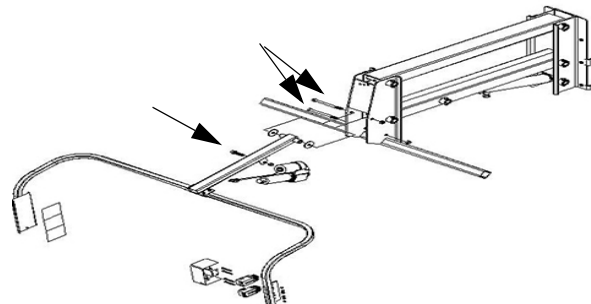

LS/Depth Command Pivot Bolts
-Typical View

Wire Harness Circuit Breaker and Fuses

The Wire Harness Circuit Breaker and Fuses (located on the right-hand side of engine) protect the cab wiring, alternator, and grid heater.

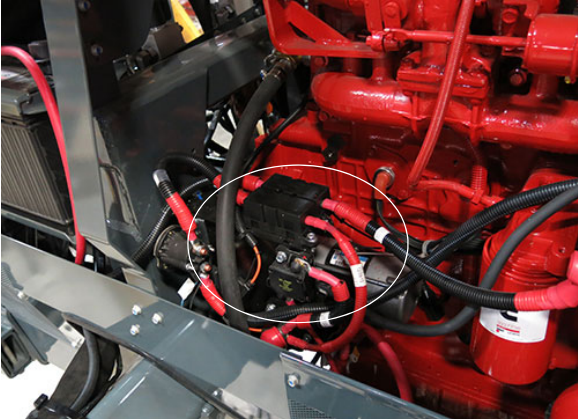

Wire Harness Circuit Breaker and Fuses
(Located on the right-hand side of engine)
-Typical View

Wire Harness Circuit Breaker and Fuse Amperage	
Cab Wiring Breaker	100 AMP
Alternator Fuse	150 AMP
Grid Heater Fuse	125 AMP

FUSE AND RELAY RATINGS

Fuses and Relays (Cab)		
Fuse	Rating (Amps)	Function
F26	5	Engine Diagnostic Power
F07	5	Hydraulic Oil Level Light
F25	5	Radio Battery Power
F29	10	Auto Steer Battery Power
F19	10	Auto Steer Power
F28	10	Backup Alarm Power
F10	10	Battery Power Relay/Signal Power Fuse
F02	10	Hagie Display Power
F22	10	Horn Power
F40	10	HVAC Clutch Power
F27	10	Ignition Power
F06	10	Shift/Brake Power
F24	10	Start Relay Power
F09	10	Switch Power to Relay Signals Power
F16	10	Traction Valve Power
F11	15	Beacon Power
F12	15	Depth Control Actuator Box Power
F17	15	Fold Valve Power
F33	15	Fuel Selector
F04	15	Radio/Dome Light/CB Auxiliary Post
F05	15	Wiper Power
F31	20	Flasher Module Battery Power
F21	20	Headlights Power
F18	20	Motor Control/Timer Power
F34	20	Seat Power
F14	20	Tasseltrol® Display/System Power
F23	20	Work Lights Power
F01	30	HVAC Power

**SECTION 6 –
ELECTRICAL SYSTEMS**



	100	Main Breaker
Relay	Ratings (Amps)	Function
CR01		Beacon Control
CR04		Headlights Logic
CR07		Horn Control
CR02		Hydraulic Level Indicator Inverter
CR06		Start Relay Control Logic
CR05		Work Lights Logic



SECTION 7 – DETASSELING SYSTEMS

DEASSELING SYSTEM COMPONENTS

The Detasseling System is a constantly monitored and continuously adjusted system. The operator's station-mounted control system receives data from the photo light sensors to determine detasseling height.

The following information in this section explains the detasseling components and their operation. Read the following section entirely before operating the Detasseling System.

NOTICE

Attachment maintenance and repair, including clearing blockages/unplugging detasseler components should be performed by qualified service personnel only.

- (A) - Cutter Heads
- (B) - LS System 12™/Depth Command
- (C) - Quad Pullers
- (D) - LS Photo Light Sensors
- (E) - Tasseltrol®/LS System 12 Control Panel
- (F) - Master Detasseler Switch
- (G) - Detasseling Head Motor Control Switches
- (H) - Hydraulic Outrigger Fold Switches (if equipped)
- (I) - All Up/Down Switches
- (J) - Depth Command Switches (if equipped)

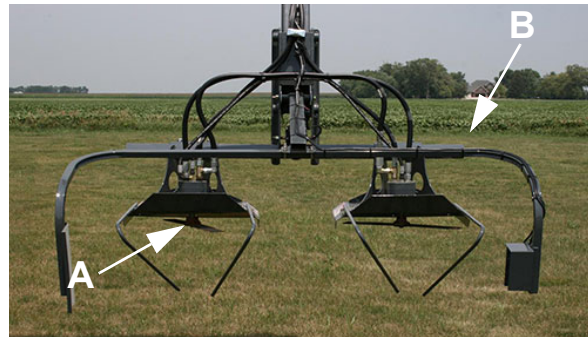

SECTION 7 – DETASSELING SYSTEMS

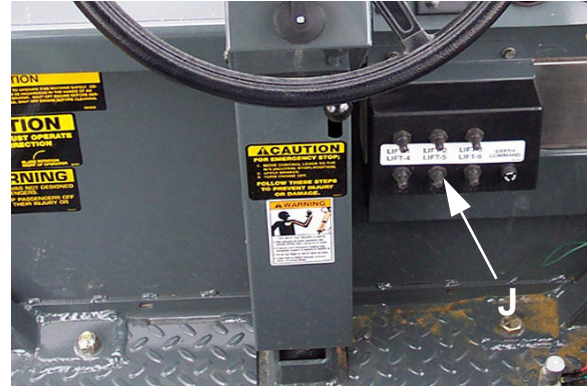

Cutter Heads



CAUTION

SEVERING OF FINGERS OR HAND.
DO NOT PLACE FINGERS OR
HAND NEAR A MOVING CUTTER BLADE,
ATTEMPT TO STOP A MOVING CUTTER
BLADE, OR PERFORM MAINTENANCE
NEAR A MOVING CUTTER BLADE.

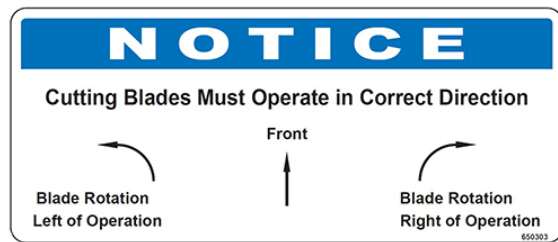

The hydraulically-driven Cutter Heads go through rows of corn and cut the tassels from the top of corn plants.

Cutter Head Speeds		
Min Speed	=	2900 RPM
Mid Speed	=	3000 RPM
Max Speed	=	3100 RPM

NOTE: It is recommended to set the cutter heads as close to “mid” speed range as possible.

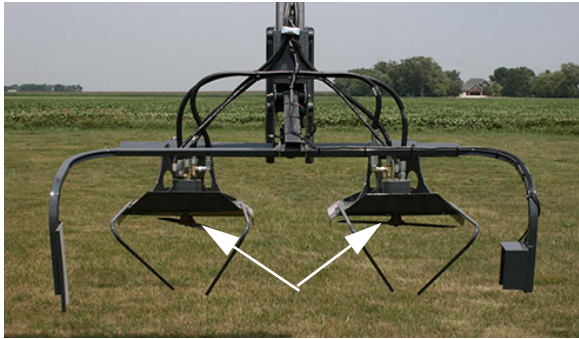

Cutter Heads
-Typical View

LS System/Depth Command

The LS System/Depth Command is an automatic height adjustment system controlled by the Tasselrol/LS System 12 Control Panel (located near the side console).

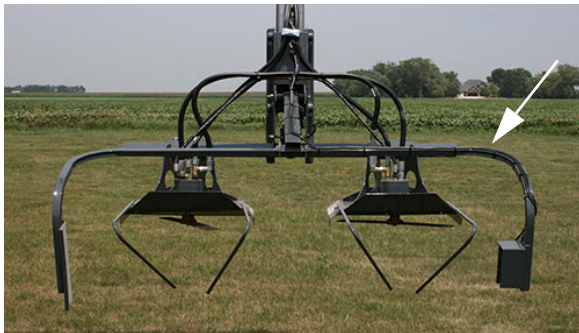

LS System/Depth Command
-Typical View

Quad Pullers



CAUTION

RISK OF INJURY FROM ROTATING TIRES. DO NOT PLACE FINGERS OR HAND NEAR MOVING QUAD PULLER TIRES, DISLodge A WEDGED OBJECT FROM MOVING TIRES, OR PERFORM MAINTENANCE NEAR MOVING TIRES.

NOTICE

Ensure quad puller tires have equal pressure. Check tire pressure daily.

NOTE: Maximum tire pressure = 10 psi (.7 bar).

The hydraulically-driven Quad Pullers go through rows of corn and pull the tassels from the top of corn plants by catching it between the Quad Puller tires moving at high speed in opposite directions.

Quad Puller Speeds		
Min Speed	=	375 RPM
Mid Speed	=	400 RPM
Max Speed	=	425 RPM

NOTE: It is recommended to set the quad pullers as close to “mid” speed range as possible.



Quad Pullers
-Typical View

LS Photo Light Sensors

The LS Photo Light Sensors detect crop height and send a signal to the LS System/Depth Command, which controls automatic height adjustment.

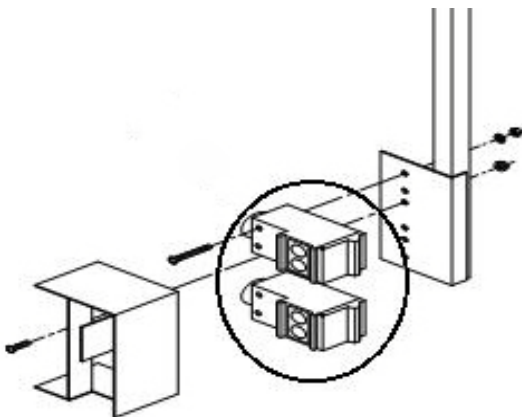

LS Photo Lights (Upper/Lower)
-Typical View

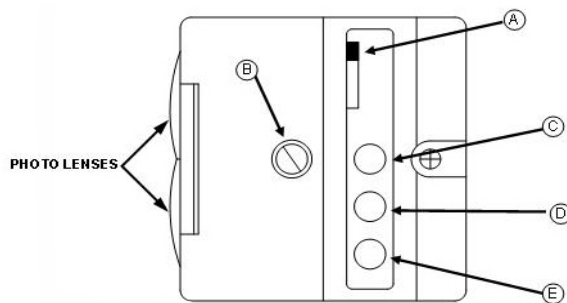

-Typical View

The upper and lower LS Photo Lights are equipped with LED lights (A, C, D, E), which indicate operation status.

- The LT/DK (Light/Dark) Switch (A) changes the activated condition of the green LED from ON (LT) to OFF (DK).
- The Sensitivity Adjustment Screw (B) should always be set to MAXIMUM.
- The Yellow LED Light (C) indicates that power is ON.
- The Green LED Light (D) indicates output energized (sending a signal to the Tasselrol Control Panel).
- The Red LED Light (E) indicates that the photo light is receiving reflected signal.

Tasselrol/LS System 12 Control Panel

The Tasselrol/LS System 12 Control Panel is used for programming the detasseling heads. The control panel can also be used to manually control the detasseling heads.



Tasselrol/LS System 12 Control Panel
(Located on the side console
- lift cover to access)
-Typical View

Refer to the Tasselrol manufacturer's operation manual for complete operating instructions and information on programming parameters.

Master Detasseler Switch

The detasseling head motors are controlled by the Master Detasseler Switch (located on the side console).

NOTE: This switch must be in the ON position to enable detasseling head operation.

- Press the Master Detasseler Switch in the UP (On) position to enable the detasseling head motors.
- Press the Master Detasseler Switch in the DOWN (Off) position to disable the detasseling head motors.



Master Detasseler Switch
(Located on the side console)
-Typical View

Detasseling Head Motor Control Switches

*** TO ENGAGE DETASSELING HEAD HYD MTRS:**

1. Reduce engine speed to an idle.
2. Clear area of unauthorized personnel.
3. Turn individual motor control switches to "ON".
4. Slowly increase engine RPM to desired speed.

650379

The Detasseling Head Motor Control Switches (located on the side console) activate the detasseling head motors (Lifts 1-6).

- Press desired Detasseling Head Motor Control Switch(es) in the UP (On) position to activate the detasseling head motors.
- Press desired Detasseling Head Motor Control Switch(es) in the DOWN (Off) position to deactivate the detasseling head motors.



Detasseling Head Motor Control Switches
(Located on the side console)
-Typical View

Hydraulic Outrigger Fold Switches

-If Equipped

The Hydraulic Outrigger Fold Switches (located on the side console) are used to hydraulically unfold/fold the outriggers.

- **To unfold the outriggers**, press and hold the corresponding Right or Left Hydraulic Outrigger Fold Switch in the OUT position until the outrigger is fully extended.
- **To fold the outriggers**, press and hold the corresponding Right or Left Hydraulic Outrigger Fold Switch in the IN position until the outrigger is fully retracted.



Hydraulic Outrigger Fold Switches
(Located on the side console)
-Typical View

All Up/Down Switches

The All Up/Down Switches (located on the Hydrostatic Drive Control Handle) are used to raise or lower all row units at the same time.

- Press and hold the RED All Up Switch to move all row units UP simultaneously.
- Press and hold the GREEN All Down Switch to move all row units DOWN simultaneously.



All Up/Down Switches
(Located on the Hydrostatic
Drive Control Handle)
-Typical View

“Up” parameters may be set to 0, 5, 10, 15, 20, or 25 seconds on the Tasselrol Control Panel. The detasseling heads will move up this amount of time without having to hold the red All Up Switch in (only in values greater than 0). All detasseling heads will hold this position when the pre-set parameter is reached.

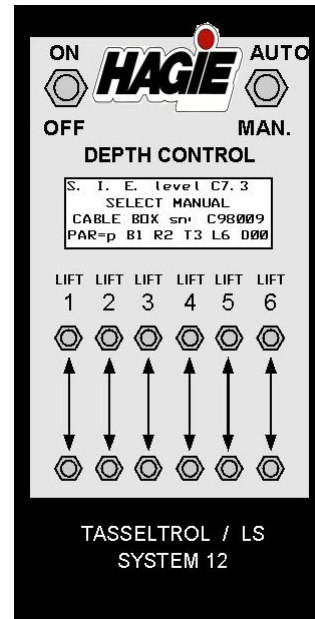

Tasselrol Control Panel
(Located on the side console
- lift panel to access)
-Typical View

NOTE: To resume automatic depth control, activate the green All Down Switch.

Refer to the Tasselrol manufacturer's operation manual for information on programming parameters.

Depth Command Switches

-If Equipped

The Depth Command Switches (located near the front of operator's station) allow the operator to adjust the LS System cutting or pulling height from the operator's seat.

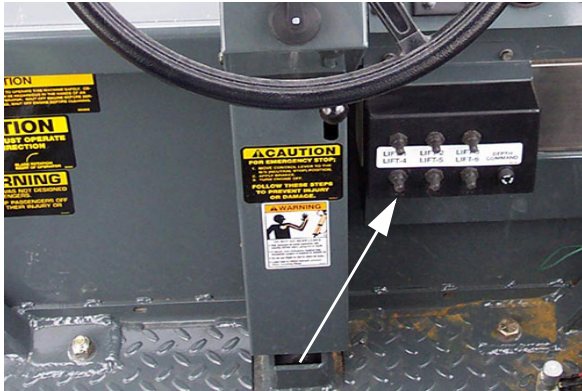

Depth Command Switches
(Located near the front of operator's station)
-Typical View

- **To lower the cutting or pulling height,** press the desired Depth Command Switch(es) in the DOWN position.
- **To raise the cutting or pulling height,** press the desired Depth Command Switch(es) in the UP position.

NOTICE

Do not operate more than two (2) depth command actuators at one time. Failure to comply may result in blowing the depth command fuse.



Depth Command Actuator
(Located on the tool bar lift head tube)
-Typical View

DETASSELING SYSTEM - OPERATION

Operating Instructions

1. Program the Tasselrol®/LS System 12™ Control Panel.

NOTE: Refer to the manufacturer's operation manual for programming instructions.



Tasselrol/LS System 12 Control Panel
(Located on the side console
- lift cover to access)
-Typical View

2. Test the Photo Light Sensors.

Auto Mode:

- Cover top photo lens and lift should move UP.
- Do not cover any of the lenses and lift should move DOWN.
- Cover bottom photo lens and lift should stay in position.

Manual Mode (Machine Off):

- When red LED is uncovered, LED should be ON.
- When red LED is covered, LED should be OFF.

SECTION 7 – DETASSELING SYSTEMS



Photo Light Sensor
-Typical View

3. Engage the parking brake.
4. Start the engine.
5. Press the Master Detasseler Switch (located on the side console) in the UP (On) position.
6. Press the corresponding Detasseling Head Motor Control Switch(es) (located on the side console) in the UP (On) position.



Master Detasseler and Detasseling
Head Motor Control Switches
(Located on the side console)
-Typical View

NOTE: If loss of hydraulic pressure occurs or the low hydraulic oil warning indicator (located on the side console) illuminates, shut down the system immediately. Failure to comply may result in system damage and will void the warranty.

7. Press and hold the Throttle Switch (located on the side console) in the UP/“rabbit icon” position to achieve the recommended RPM to operate the detasseling head motors.

NOTICE

Operating the Detasseling System below the recommended 2500 engine RPM will not provide the system with adequate hydraulic oil flow and may cause degraded or poor performance.



Throttle Switch
(Located on the side console)
-Typical View

NOTE: Detasseling heads will be available for immediate use by increasing engine RPM.

TASSELTROL®/LS SYSTEM 12™

Setting Up

Enter Parameter Mode

- Press the Auto/Manual Switch (located on the Tasseltrol Control Panel) in the UP (Auto) position.

Match the Machine Valve Type

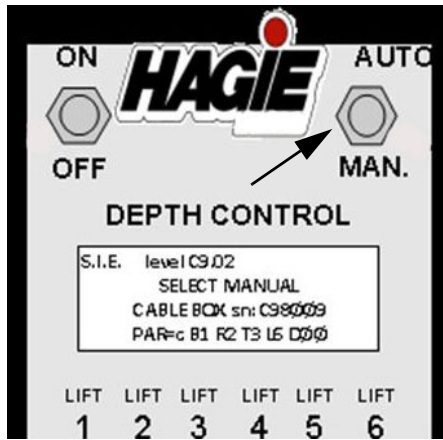

Auto/Manual Switch
(Located on the Tasseltról Control Panel)

- Press the On/Off Switch (located on the Tasseltról Control Panel) in the UP (On) position.
- On the LCD display will be four lines. The top line displays the program level. The second line will flash “Select Manual” (as a warning that you are about to enter parameter adjustment mode). Current parameter settings are displayed on the bottom line (values for B, R, T, L, and D are typically set). The machine type will vary from o, p, or c, depending on valve system.

NOTE: “L” may vary, depending on the number of lifts on the machine.

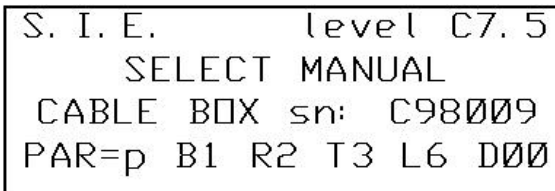

NOTICE

Machines with Tasseltról software version 8.7 and greater are equipped with an enhancement that allows the operator to set the lift speeds for auto mode functions.

NOTICE

Ensure the machine valve type is selected correctly to match the machine in which the Tasseltról control box is installed on.

- Press the LIFT 1 UP Switch (located on the Tasseltról Control Panel) **two (2) times** to display the machine type selected.

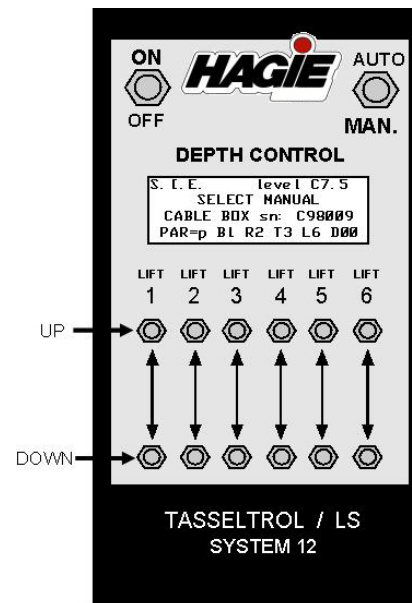

- The o, p, or c (located to the right of “NEXT” on the bottom line of the LCD display) indicates the type of machine. Press the LIFT 2 UP Switch. The display will now change to the “Select Machine Type” screen.

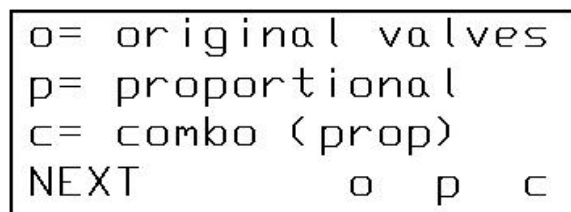

- Select the type of machine that the unit is installed on.

SECTION 7 – DETASSELING SYSTEMS



NOTE: For machines built prior to 2007 with the original valve system, press the LIFT 4 Switch under the “o”. If the machine is equipped with proportional valves, press the LIFT 5 Switch under the “p”.

For machines built 2007 or newer with proportional valves, press the LIFT 6 Switch under the “c”.

- The display will now revert back to the “Select Manual” screen with the machine type that you have just selected displayed on the bottom line.

Match How Many Lifts are on the Machine

(System must be in parameter mode before proceeding)

- Press the LIFT 1 UP Switch **two (2) times** to display how many lifts are on.

NOTE: “L6” (A) on the display indicates that all six lifts are ON.

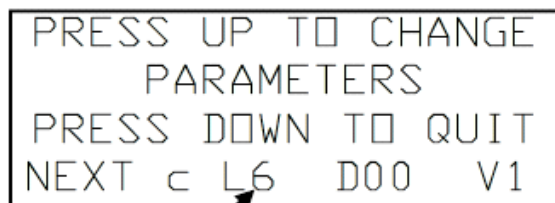

(A)

- To change the number of lifts to match your machine, press the LIFT 3 UP Switch. This will display the LIFTS: ON-OFF screen (B).

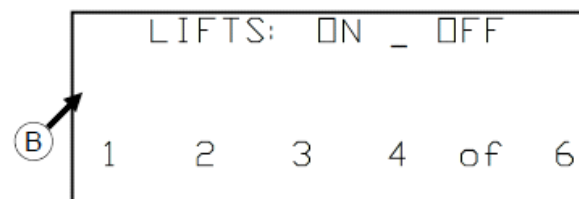

- Press the LIFT UP Switch under the corresponding lift that you want to turn on/off.

NOTE: “of” = OFF.

- After selecting which lifts are to be on/off, press the LIFT 1 DOWN Switch **two (2)**

times to exit the screen and save new parameter setting.

Your machine is equipped with six (6) hydraulic lift hoses, regardless of the number of lifts available. For machines with less than six lifts, unused lift hydraulics will be capped off. When matching how many lifts are on your machine, program the correct number of lifts into the display to ensure maximum performance.

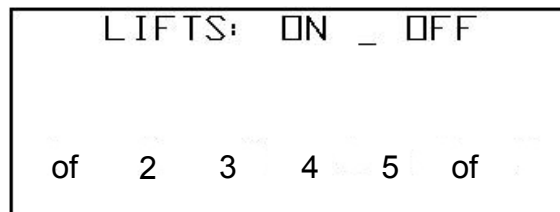

4-Lift Machine

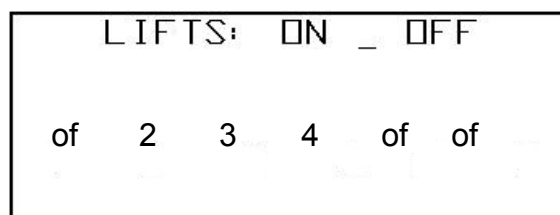

3-Lift Machine

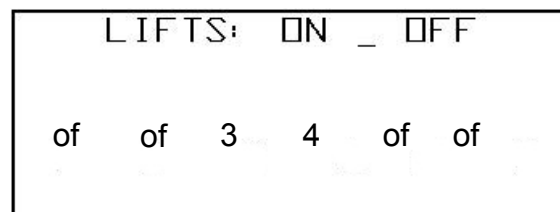

2-Lift Machine

Establish “D” and “V”

(System must be in parameter mode before proceeding)

- Press the LIFT 1 UP Switch **two (2) times** and the display will show the current setting of **Dwell (A)** for “all up” and **Valve Compensation (B)** as either 1=ON, or 0=OFF.

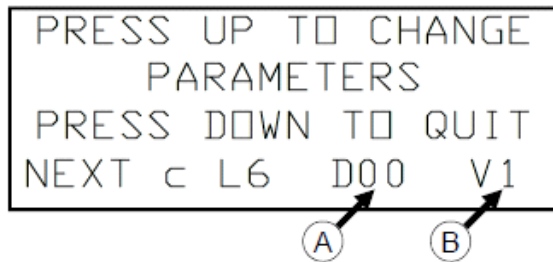

- The “D” value indicates how many seconds that the lifts will travel up after the All Up Switch (located on the Hydrostatic Drive Control Handle) is pressed momentarily. This time can be changed by pressing the LIFT 4 UP Switch.

NOTE: The time is factory preset to 0, but can be set to a value of 25 while adjusting the machine valves.

- Pressing the LIFT 4 UP Switch will add five (5) seconds to the value each time until “D25”, then will return to “D00”. When the value is set to D00, the up motion stops as soon as the All Up Switch is released. If the value is set to anything greater than D00, the All Up Switch will only need to be pressed momentarily and the lifts will continue the up move until the parameter has been reached.
- The “V” value indicates whether or not the valve automatic compensation is performed. Press the LIFT 6 UP Switch to change this value.

NOTE: This value is typically left at “V1”.

Set the Lift Up Speeds

(System must be in parameter mode before proceeding)

- Press the LIFT 1 UP Switch **three (3) times** and the display will show the current setting of the Up Speed for an auto, manual, and all-up move with a value from 01 to 10.
- With the value set to 01 in “MAN” or to 03 in “AUTO” and “ALL”, the lifts will move slow enough to see if any are moving slower than the rest. These settings are useful when adjusting the offset of the values to get all the lifts to move at the same speed. Typically, these values

are set to 05 for a fairly fast speed. The values can be changed by pressing the Up/Down Switches under AUTO, MAN, or ALL.

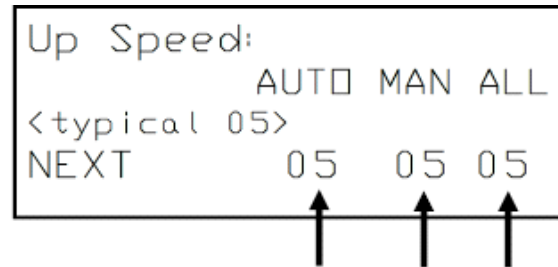

NOTE: Values can be saved by pressing the LIFT 1 DOWN Switch to exit the screen and save the new parameter setting.

Set the Lift Up Offset

(System must be in parameter mode before proceeding)

- Press the LIFT 1 UP Switch **four (4) times** and the display will show the current setting of the Up Offset for the first three lifts. Pressing NEXT again will show the offset setting for the last three lifts. The Up Offset for each valve can be set from -19 to +20, as needed to get the lift speed to match the speed of the other lifts.

NOTE: The more positive the number, the faster the lift will move. Typically, the offset is initially adjusted at a very slow speed by setting the Lift Up Speed to either 01 or 03.

```
Up Speed:
      AUTO MAN ALL
<typical 05>
NEXT   03  01  03
```

```
Up Offset:
      1    2    3
<typical 00>
NEXT  +01 -06  00
```

- Exit parameter mode and check the speed of each lift by moving it manually with the Up/Down Switches.
- Correct the fastest and slowest lifts to match the average speed by changing the offset value with the Up/Down Switches for that lift while in the Lift Up Offset parameter mode.
- When finished setting the offset values, return the speed setting back to approximately 05.

```
Down Offset:
      4    5    6
<typical 00>
NEXT  -07 +05  00
```

- With all the lifts at their lowest points, select AUTO.
- Press the All Up Switch (located on the Hydrostatic Drive Control Handle) so the lifts all move up at the same time. Correct the values for any lifts that are not close to the speed of the others.

NOTE: Values can be saved by pressing the LIFT 1 DOWN Switch to exit the screen and save the new parameter setting.

NOTICE

To get all the lift speeds even, you may need to lower the speed below 05. This will ensure that flow is being controlled by the value rather than restricted by the .042" (.1 cm) orifice. After adjusting the offset parameters for even up speeds, the up speed value can be increased back to 05.

Set the Lift Down Speeds

(System must be in parameter mode before proceeding)

- Press the LIFT 1 UP Switch **six (6) times** and the display will show the current setting of the Down Speed for an auto, manual, and all-resume move with a value of 01 to 10.
- With the value set to 03, the lifts will move a little slower. This setting of 03 is useful when adjusting the offset of the values for getting all the lifts the same speed. Typically, these values are set to 05 for a fairly fast speed. The values can be changed by pressing the Up/Down Switches under the AUTO, MAN, or ALL.

NOTE: Values can be saved by pressing the LIFT 1 DOWN Switch to exit the screen and save the new parameter setting.

```
Down Speed:
      AUTO MAN ALL
<typical 05>
NEXT   05  05  05
```

Set the Lift Down Offset

(System must be in parameter mode before proceeding)

- Press the LIFT 1 UP Switch **seven (7) times** to display the current setting of the Down Offset for the first three lifts.
- The Down Offset can be adjusted for a value from -19 to +20.

NOTE: The more positive the number, the faster the lift will move. Typically, the offset is initially adjusted at a slower speed by setting the Lift Down Speed to 03.

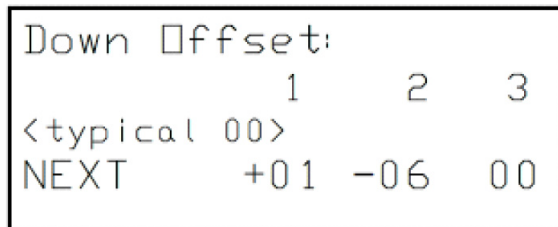
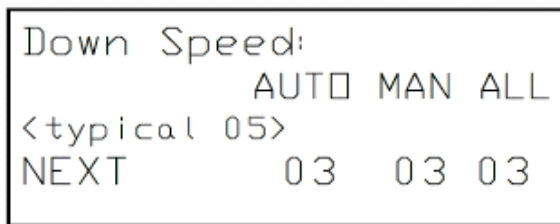

- Exit parameter mode and check the speed of each lift by moving it manually with the Up/Down Switches.
- Correct the fastest and slowest lifts to match the average speed by changing the offset value with the Up/Down Switches for that lift while in the Down Offset parameter.
- When finished setting the offset values, return the speed setting back to approximately 05.
- With all lifts at their highest points, select AUTO so all lifts move down together. Correct the values for any lifts that are not close to the speed of the others.

NOTE: Values can be saved by pressing the LIFT 1 DOWN Switch to exit the screen and save the new parameter setting.

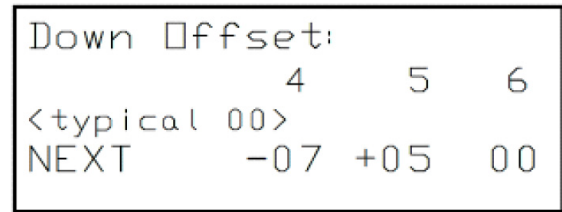

Once you have set the operating parameters, you may adjust the Response Parameters. These parameters are used to adjust the response of the controller and seldom need changing. The parameter values are stored in flash memory and will be retained even when no battery power is present.

NOTICE

Once parameters have been set, minimal adjustment is required.

The programmable control panel is factory preset with the following parameter defaults:

- **Response Parameter (R2)**
- **Top Parameter (T3)**
- **Bottom Parameter (B1)**

These parameters will always be displayed until the control panel is reprogrammed. Once reprogrammed, the new values for the parameters will be displayed on the control panel.

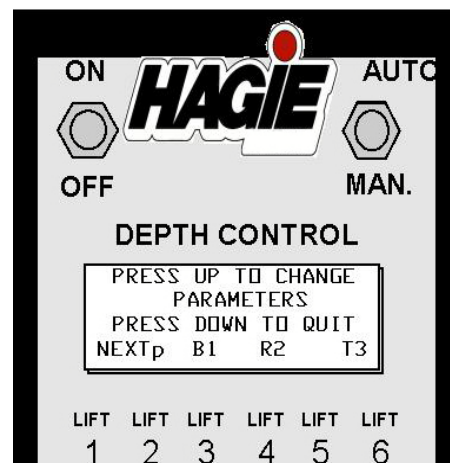

To program the unit, first select the Response Parameter. If further adjustment is required for top and/or bottom parameters, continue with their adjustments.

Tasselrol Response Parameter

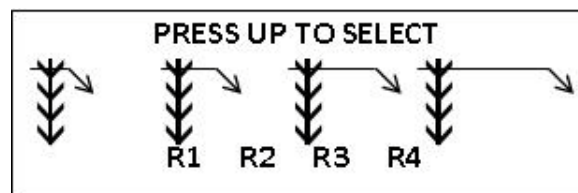
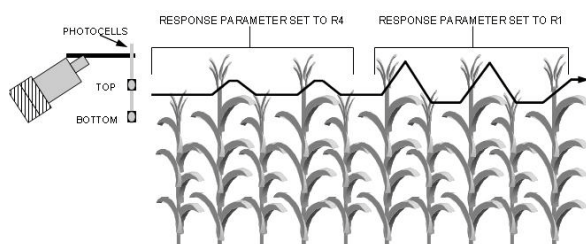

The Response Parameter is used to adjust the response time of both photocells - how quickly the down motion starts when no corn is detected by either top or bottom cells, and how quickly the up motion is stopped when corn is no longer detected by the top cell. This can be changed by selecting R1, R2, R3, or R4.

NOTE: More corrections will occur when R1 is selected and fewer with R4 selected. The normal (default) value for this parameter is R2, but can be set to any desired value.

Use the Response Parameter to adjust overall correction activity and to compensate for ground speed. If the quad pullers are moving too quickly and frequently, the Response Parameter can be increased toward R4. If the quad pullers are too slow to respond to changes in corn depth, decrease the parameters toward R1. Generally, this parameter can be left at R2.

To display the Response Parameter:

- Press the Auto/Manual Switch (located on the Tasselrol Control Panel) in the UP (Auto) position.
- Press the On/Off Switch (located on the Tasselrol Control Panel) in the UP (On)

position. Wait approximately three (3) seconds for the “Select Manual” message to appear.

- Press the LIFT UP Switch under “PAR”.
- Press the LIFT UP Switch under the “R” value.

The active value of the parameter is indicated by it blinking on and off while the other three options are displayed continuously.

To select a new value for the parameter:

- Press the LIFT UP Switch under the desired selection.
- After selecting one of the four options, press the LIFT 1 DOWN Switch to escape this parameter.
- To save new values and escape the parameter mode, press the LIFT 1 DOWN Switch a second time.

Tasselrol Top Parameter

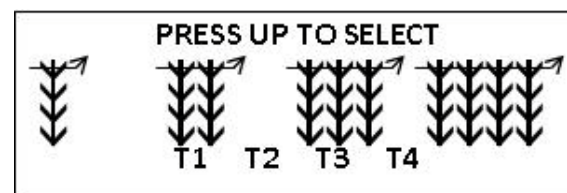
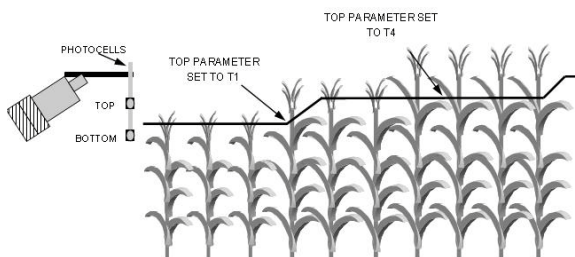

The Top Parameter is used to adjust the sensitivity time of the top photocell. The top photocell starts the up motion when its light path is blocked by corn. How much corn it has to see before starting the up move can be changed by selecting one of the four values: T1, T2, T3, or T4.

NOTE: When T1 is selected, less corn is required to start an up move. The normal (default) value for this parameter is T3, but can be set to any desired value.

If the quad pullers move up too easily when a taller stalk of corn passes, increase the parameter toward T4. If the quad pullers stay deep too long when taller corn passes, decrease the parameter toward T1. Generally, this parameter can be left at T3.

To display the Top Parameter:

- Press the Auto/Manual Switch (located on the Tasselrol Control Panel) in the UP (Auto) position.
- Press the On/Off Switch (located on the Tasselrol Control Panel) in the UP (On) position. Wait approximately three (3) seconds for the “Select Manual” message to appear.
- Press the LIFT UP Switch under “PAR”.
- Press the LIFT UP Switch under the “T” value.

The active value of the parameter is indicated by it blinking on and off while the other three options are displayed continuously.

To select a new value for the parameter:

- Press the LIFT UP Switch under the desired selection.
- After selecting one of the four options, press the LIFT 1 DOWN Switch to escape this parameter.
- To save new values and escape the parameter mode, press the LIFT 1 DOWN Switch a second time.

Tasselrol Bottom Parameter

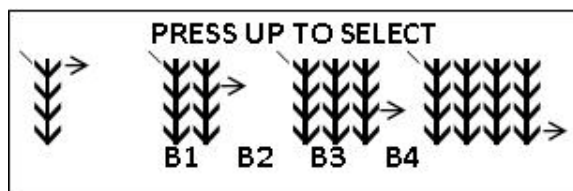
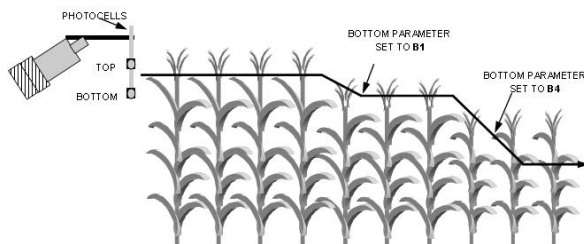

The Bottom Parameter is used to adjust the sensitivity time of the bottom photocell. The bottom photocell stops the down motion when it's light path is blocked by corn. Selecting one of the four values (B1, B2, B3, or B4) will set how much corn the photocell has to see before it stops moving down.

NOTE: When B1 is selected, the down move will stop as soon as corn is detected. The normal (default) value for this parameter is B1, but can be set to any desired value.

If the quad pullers run too shallow after moving down into shorter corn, increase the parameter toward B4. If the quad pullers move too deep when going into shorter corn or oscillates between the top and bottom photocells, decrease the parameter toward B1. Generally, this parameter can be left at B1.

To display the Bottom Parameter:

- Press the Auto/Manual Switch (located on the Tasselrol Control Panel) in the UP (Auto) position.
- Press the On/Off Switch (located on the Tasselrol Control Panel) in the UP (On) position. Wait approximately three (3) seconds for the “Select Manual” message to appear.
- Press the LIFT UP Switch under “PAR”.
- Press the LIFT UP Switch under the “B” value.

The active value of the parameter is indicated by it blinking on and off while the other three options are displayed continuously.

To select a new value for the parameter:

- Press the LIFT UP Switch under the desired selection.
- After selecting one of the four options, press the LIFT 1 DOWN Switch to escape this parameter.
- To save new values and escape the parameter mode, press the LIFT 1 DOWN Switch a second time.

Operating the Control Panel with Normal Parameter Settings

- Engage the parking brake.
- Turn the ignition to the ON position.
- Turn the Tasselrol Control Panel ON.
- Press the Auto/Manual Switch in the DOWN (Manual) position.

NOTE: At this time, the display will read “MANUAL” in addition to other information identifying the control panel.

- Press the individual row switches for up or down movement. An arrow on the display will indicate direction of each lift.

NOTE: “P” indicates pressure, UP is only available on “o-type” machines, and UP/DOWN are available on “p and c-type” machines.

- If the Auto/Manual Switch is left in the AUTO position when the unit is first started, the display will tell you to “SELECT MANUAL”. After you have selected MANUAL, switch back to the AUTO position.
- To override the system, press the desired LIFT UP Switch to raise the attachment. When the switch is released, the system will revert back to AUTO mode.
- If the ignition is left on and the Auto/Manual Switch is left in the AUTO position, the down coils on the electro-hydraulic valve will lose power after approximately 45 seconds. To reactivate, press the Auto/Manual Switch from AUTO to MANUAL, then back to AUTO.
- The control panel is set up with a feature that if a unit loses contact during operation in AUTO mode, the unit will automatically rise. If this should occur, switch to MANUAL mode and determine cause for the malfunction.

Short Corn Operation

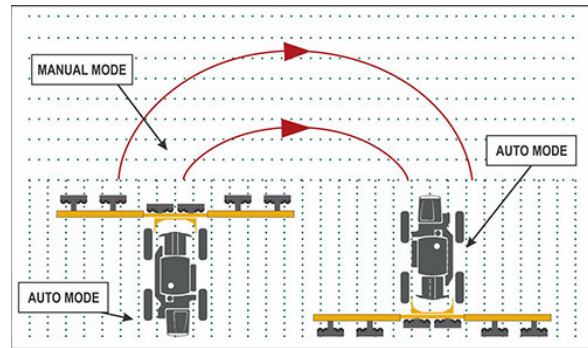

When operating the LS System, always select MANUAL when first entering the field. Once you have determined your operating speed and cutting/pulling depth, select AUTO. When you come to an area where the corn is very short, such as a low spot in the field, you may want to switch to the MANUAL position until you reach taller corn.

Always switch to the MANUAL position before you reach the end rows (see previous illustration). This will allow the cutter or puller heads to maintain their cutting or pulling height when re-entering the field. You may then switch back to AUTO.

NOTE: You may choose to use the All Up/ Hold function instead of switching to manual. This function will raise all the detasseling heads in one motion.

Additional Features

To temporarily lock a lift up, press and hold the LIFT UP Switch for the corresponding lift while switching from MANUAL to AUTO mode. The display will show “L” for that lift, which indicates that it is locked and will not move down automatically.

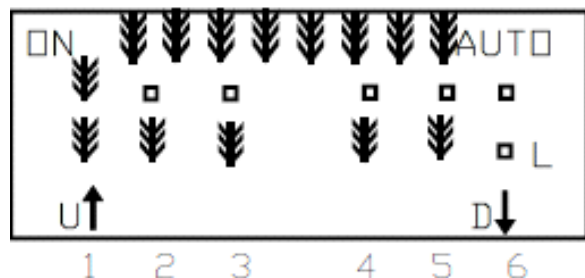

NOTE: The lift will return back to normal operation when MANUAL mode is again selected.

To display the current supply voltage for the controller, press the All Up Switch while in MANUAL mode.

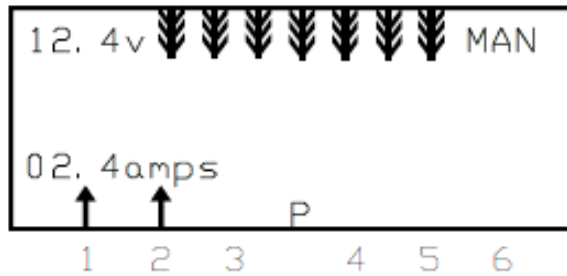

TASSELTROL FLOWCHART

Turn on the TASSELTROL® power switch with the “AUTO/ MANUAL” switch in “AUTO” position. This is how to enter the adjusting mode. Select MANUAL to save parameters and return to AU-TO for automatic head adjustments.

Turn on the TASSELTROL® power switch with the “AUTO/ MANUAL” switch in “MAN” position.

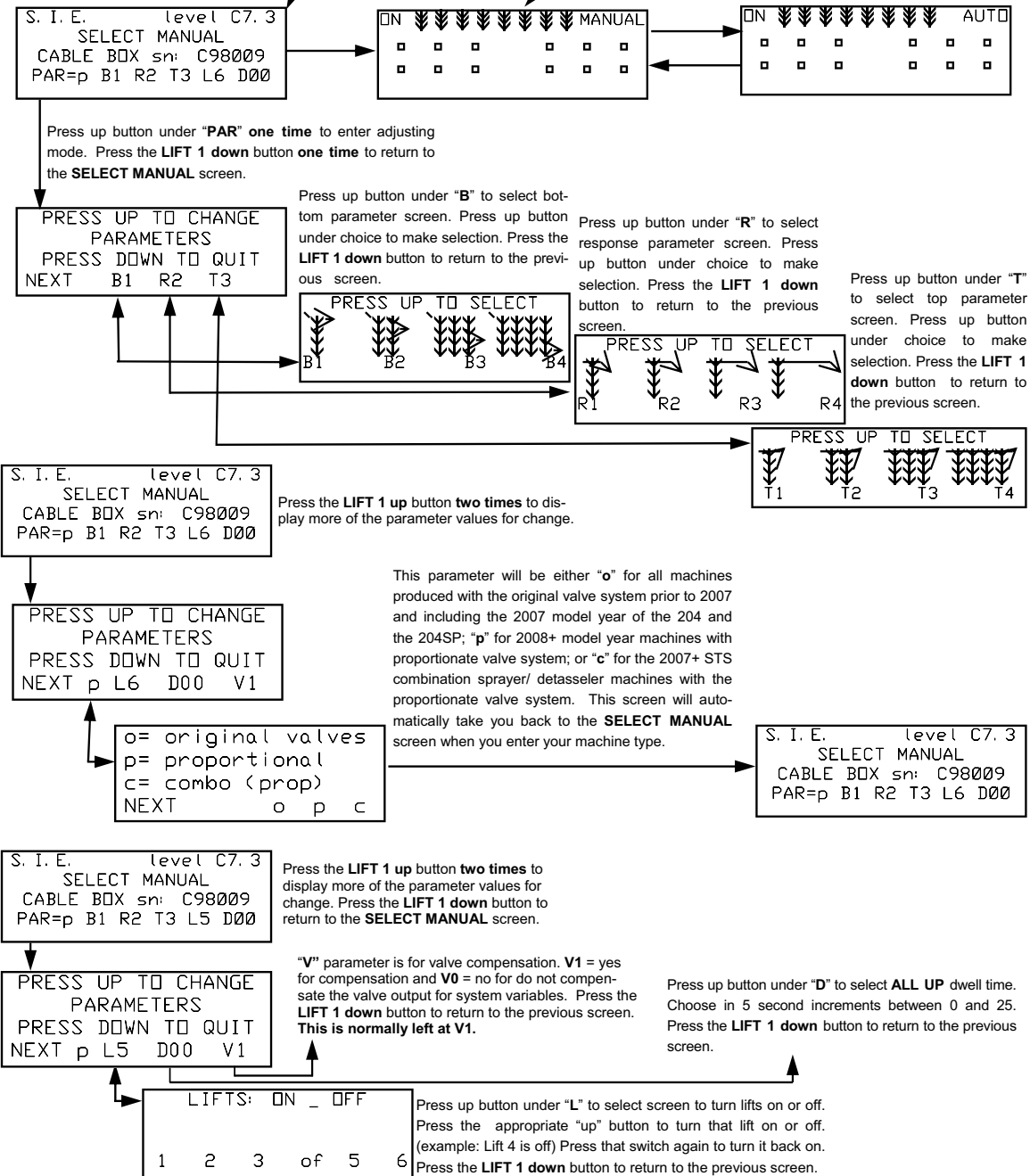

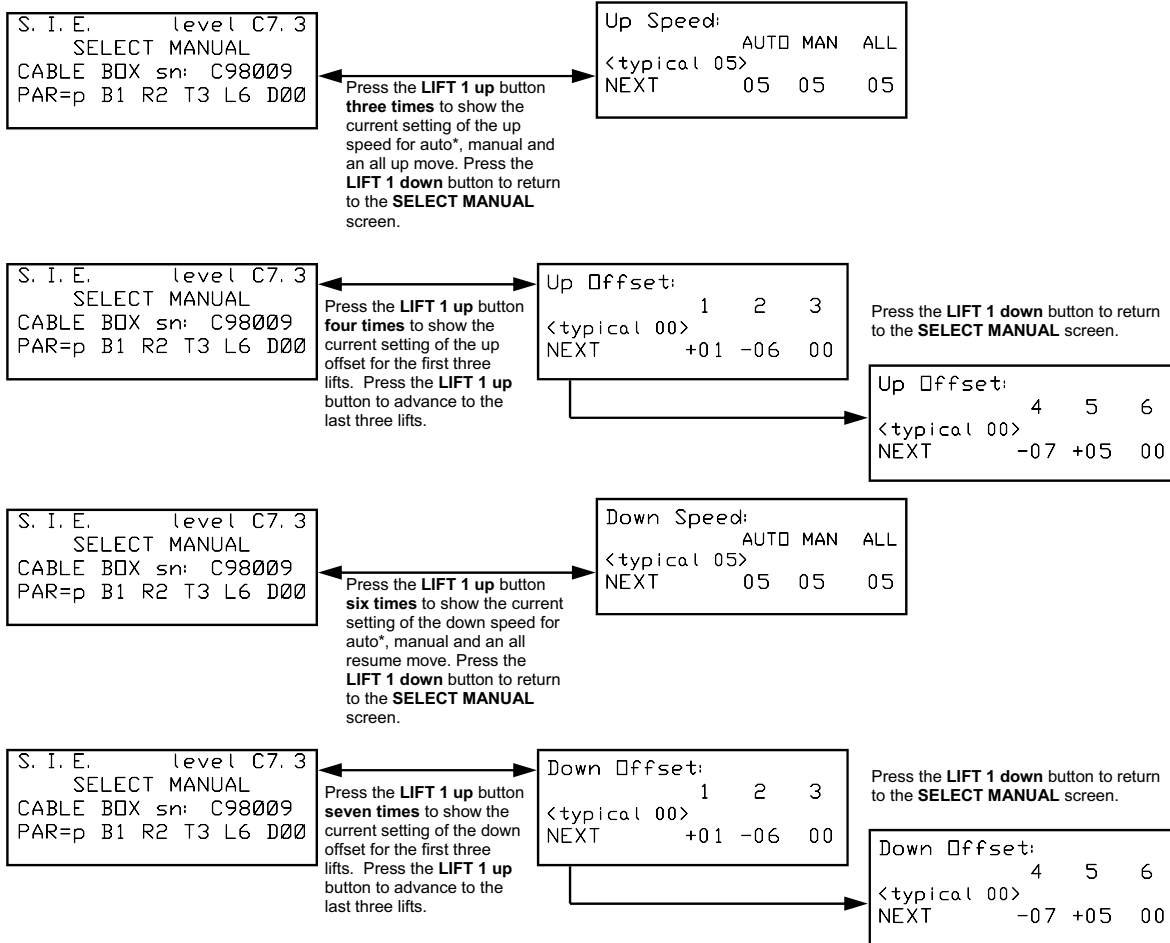

NOTE: With the exception of the machine valve type screen, which automatically reverts upon changing, you may advance through all the parameter settings while making changes without returning to the **SELECT MANUAL** screen each time by pressing the **LIFT 1 up** button instead of the down button. **LIFT 1 down** saves the changes upon exiting the parameter screen.

KEY

- = reflector with no corn present
- ⏏ = the photo cell is blocked by corn
- ↓ = the down valve is on
- ↑ = the up valve is on

P = the pressure valve is on. Displayed in the lower middle part of the screen.

LV = the source of voltage fell below 10.8 vdc for a low voltage condition. Displayed in the upper left corner of the screen in place of "ON" when situation occurs.

SHORT = current exceeded 18 amps and outputs are turned off for a short time. Displayed in place of "ON" when situation occurs.

t = task not completed in the 30 seconds allowed, will resume on next task. Displayed in place of "ON" when situation occurs.

of = a lift is turned off by the parameter settings

L = the operator locked that lift up until manual is selected again. Displayed next to bottom photo cell icon for the valve that is locked.

ALL HOLD = the operator pressed the ALL-UP button on the hydrostatic handle. Displayed in the middle of the screen.

U, D, or B = either the up, down, or both manual buttons are pressed for that lift. Displayed next to the arrow for the lift being used.



SECTION 8 – MAINTENANCE AND STORAGE



Optimizing Our Customers Growth™

Hagie Manufacturing Company
 P.O. Box 273
 Clarion, IA 50525-0273
 Toll Free: 800-247-4885
 Fax: 515-532-3553
 Email: hagiehelp.com

LUBRICANT RECOMENDATIONS			
Component	General Specification	Recommended Lubricant	Recommended Service Interval
Engine Oil	API CJ-4, 15w40	Mobil Delvac™ 1300 Super 15w40	Oil Analysis Guidance or 500 hours
Engine Coolant	Fully formulated antifreeze/coolant ASTM D6210	Fleet Charge Coolant SCA Pre-Charged	2000 Hours or 2 Years
Hydraulic Oil	ISO 11158, Type HM/HV, VG 46	Mobilfluid™ 424 or product meeting General Specification	Oil Analysis Guidance or Change @1000 Hrs
Planetary/Hub Drives	Synthetic API GL-5/MT-1	Mobil Delvac Synthetic Gear Oil 75W-90	250 hrs or Yearly
Greased Points	NLGI 2, EP, ISO 220 No Solids or Molybdenum	Mobilgrease XHP™ 222 A non-moly grease	Daily

PLEASE CONSULT YOUR MANUAL FOR FURTHER DETAILS

Call 1.800.662.4525 for Mobil Product Specifications and Infomation or visit www.mobilindustrial.com

Hagie PN: 650466

SERVICE - FLUIDS

Hydraulic Oil

NOTICE

Ensure area is clean before changing hydraulic oil and filters to avoid contamination, such as dirt and debris. Failure to comply may result in severe hydraulic system damage.

NOTICE

Ensure engine is off before filling hydraulic oil reservoir.

Check the Hydraulic Oil Reservoir Sight Gauge level daily. Add just enough fluid to maintain oil level at mid-sight gauge.

NOTE: Hydraulic oil expands when heated. Always check oil level when it is cool.

NOTE: Ensure the lift cylinders are in the lowered position before checking hydraulic oil level.



Hydraulic Oil Reservoir Sight Gauge
 (Located on front of hydraulic oil reservoir)
 -Typical View

A Low Hydraulic Oil Indicator (located on the side console) will illuminate when hydraulic oil level drops too low for safe operation. If this indicator light illuminates, shut down the engine and refill hydraulic oil reservoir to satisfactory level.



Low Hydraulic Oil Indicator
(Located on the side console)
-Typical View

NOTE: Replace hydraulic oil every 500 hours of operation.

Filling the Hydraulic Oil Reservoir

Hydraulic oil can be added two different ways:

1. Through the hydraulic oil fill port (located on the side of the hydraulic return filter housing); or
2. Through the top of the hydraulic return filter housing. Remove bolts and cover to access.

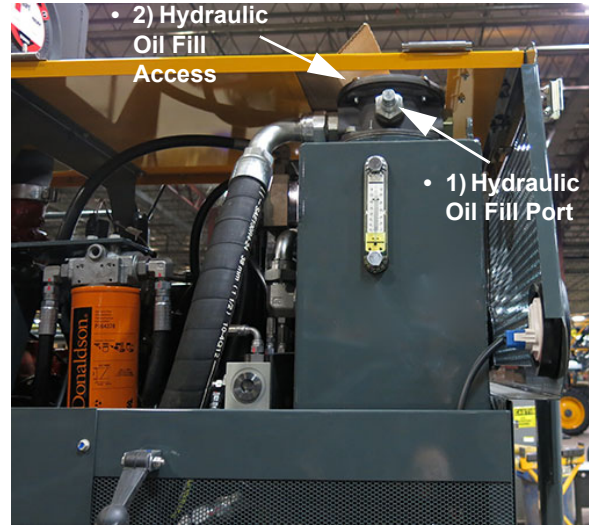

Hydraulic Oil Fill Options
-Typical View

Method 1 - Filling Through Hydraulic Oil Fill Port (Preferred Method)

NOTE: A hydraulic oil pump is required to fill through the hydraulic oil fill port, as gravity will not work and there is a small pressure to be overcome.

NOTE: Two (2) quick coupler fittings are provided in your tool kit to provide connection between the hydraulic oil fill port and the hydraulic oil pump that you are using.

- Remove the fill port rubber end cap.
- Attach hydraulic oil pump quick-connect fitting to the hydraulic oil fill port.
- Slowly squeeze pump handle and fill reservoir until oil level reaches mid-sight gauge.



Filling Tank Through Hydraulic Oil Fill Port
-Typical View

- When finished filling, release pump handle and disconnect quick-connect fitting from fill port.
- Reinstall fill port rubber end cap.

Method 2 - Filling Through Hydraulic Return Filter Housing

- Using a 1/2” wrench, remove the four (4) bolts (located on top of the hydraulic return filter housing) and set aside.
- Lift edge of housing cover and maneuver toward rear side of access opening. Remove cover and set aside.

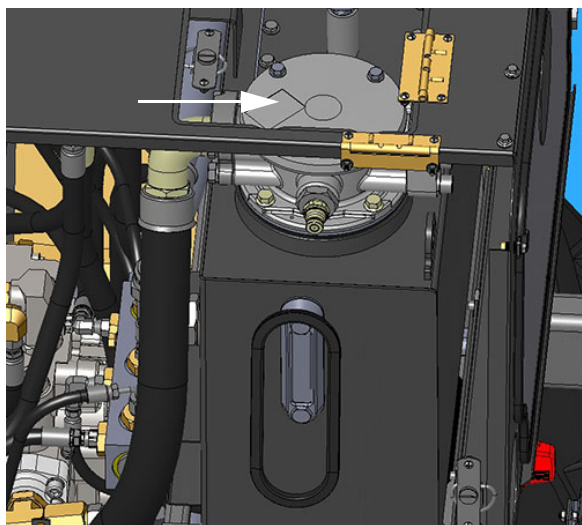

Filling Tank Through Hydraulic Return Filter Housing
-Typical View

- Fill reservoir until oil level reaches mid-sight gauge.

- When finished filling, reinstall hydraulic return filter housing cover and bolts.

Type

Premium hydraulic fluids containing high quality rust, oxidation, and foam inhibitors are required. Hagie Manufacturing Company recommends Mobilfluid® 424 (complying with ISO 11158, type HM/HV, VG 46 specifications).

Wheel Hub Oil

Torque Hub®

Each wheel hub should maintain an oil level of half-full at all times. Less than that would limit lubrication and overfilling would cause overheating and machine damage.

To check the oil level:

NOTE: Check wheel hub oil level every 100 hours of operation.

1. Position wheel hub so one of the drain plugs is positioned at 12 o'clock. The other plug will be positioned at either 9 o'clock or 3 o'clock. See following illustration.

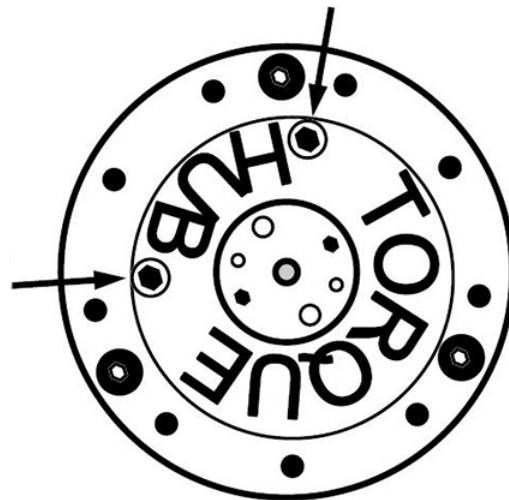

2. Remove the bottom plug. If no oil comes out, the oil level is too low.

NOTE: Hagie Manufacturing Company recommends Mobil Delvac™ synthetic gear oil (75W-90) with EP features (complying with API GL-5/MT-1 specifications).

3. If oil is needed, remove the top plug and fill just until oil begins to come out of the lower hole.
4. Reinstall plugs when oil level is satisfactory.

To change the oil:

NOTE: Wheel hub oil should be changed after the first 50 hours of operation. After that, it should be changed every 250 hours or yearly, whichever occurs first.

1. Position one of the wheel hub plugs at 6 o'clock and the other at 3 o'clock or 9 o'clock.
2. Remove the bottom plug to drain oil.
3. Once all of the oil is drained, reinstall the bottom plug and remove the top plug.
4. Refill with gear oil as previously described.
5. Reinstall top plug.

General Maintenance**NOTICE**

Failure to rotate the wheel hub and disperse oil may cause rusting and internal wheel hub damage.

If your machine is going to sit unused for an extended period of time, occasionally rotate the wheel hubs by driving the machine forward and backward - at least half of a tire rotation to adequately coat all internal hub parts. This will prevent rusting if moisture inadvertently entered the wheel hub during an oil change.

Engine Oil**NOTICE**

Never operate the engine with oil level below the "L" (low) mark or above the "H" (high) mark on the engine oil dipstick.

NOTICE

The engine must be level when checking the oil level to ensure accuracy.

The Engine Oil Dipstick is located on the left-hand side of the engine - open hood panel to access. Wait at least five (5) minutes after shutting the engine off before checking the oil level.

NOTE: Check the engine oil level daily.

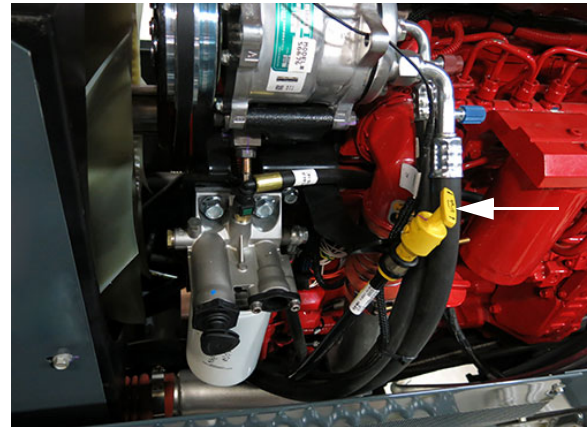

Engine Oil Dipstick
(Located on the left-hand side of engine - open hood panel to access)
-Typical View

Capacity

- Engine Oil Dipstick Capacity (low to high mark) = 3.2 quarts (3 L)
- Engine Oil Pan Capacity (including filter) = 13.7 quarts (13 L)

Type

- Valvoline Premium Blue® Classic Engine Oil - 15W-40 (recommended)

NOTE: Change the engine oil every 250 hours of operation or yearly, whichever occurs first.

Engine Oil Fill

Engine oil can be added through the Engine Oil Fill Port or the Remote Engine Oil Fill Port (both located on the left-hand side of engine - open hood panel to access).

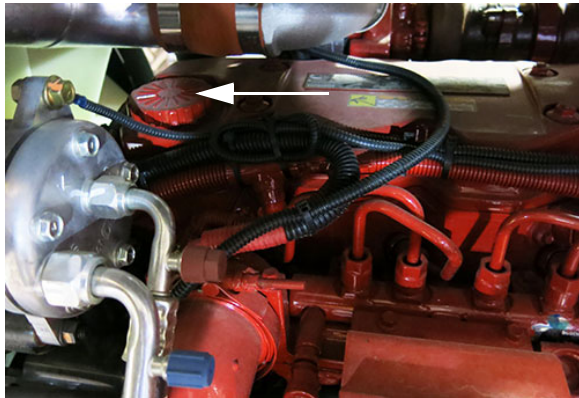

Engine Oil Fill Port
(Located on the left-hand side of engine - open hood panel to access)
-Typical View

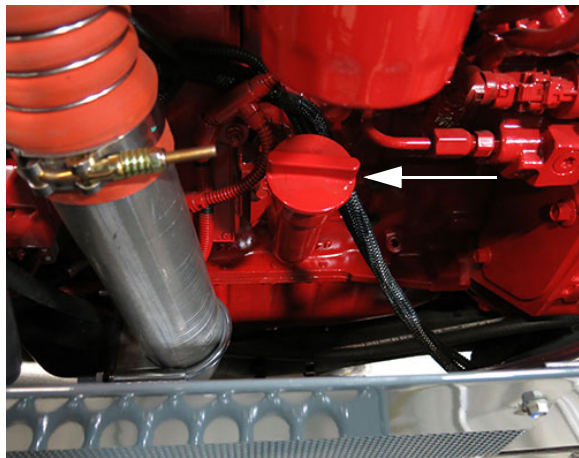

Remote Engine Oil Fill Port
(Located on the left-hand side of engine - open hood panel to access)
-Typical View

The cooling system should always be sufficiently charged with an adequate mixture of antifreeze and water, regardless of climate, to maintain broad operating temperature range. Follow the coolant manufacturer's recommendations for your climate.

NOTE: The cooling system has been factory-charged with an ethylene glycol-based antifreeze.

Checking Coolant Level/ Concentration

WARNING

Allow engine and radiator to cool before removing radiator cap. Removing radiator cap while the engine is hot can cause coolant to spray out, resulting in serious injury.

CAUTION

Pressurized cooling system. Remove cap slowly.

NOTE: Check coolant level daily.

Cooling System

NOTICE

Ethylene Glycol-based antifreeze and Propylene Glycol-based antifreeze should never be mixed.

Changing Coolant

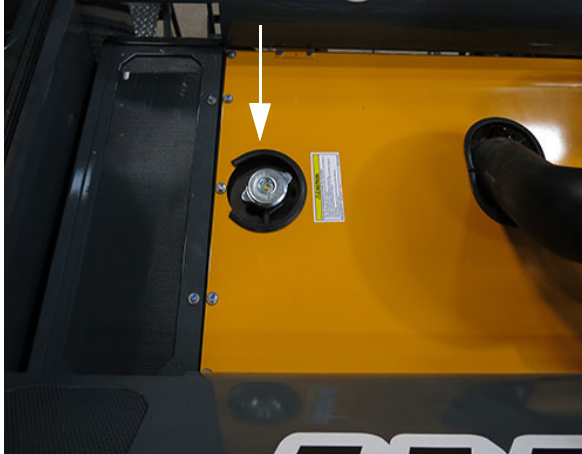

Radiator Cap
(Located behind the operator's station)
-Typical View

A 50/50 ethylene glycol and water mixture is a conservative mixture, which allows protection against both overheating and freezing.

NOTE: If a stronger antifreeze mixture is required, ensure not to exceed the engine manufacturer's guidelines for antifreeze-water mixing.

The following Ethylene Glycol Table gives a few examples of ethylene glycol antifreeze/water mixture protection values.

Ethylene Glycol		
40%	-23° C	-10° F
50%	-37° C	-34° F
60%	-54° C	-65° F

Coolant concentration should be checked every 500 hours of operation or at the beginning of each season, whichever occurs first. A refractometer should be used to check concentration.

NOTE: "Floating Ball" type density testers are not accurate for use with a heavy duty diesel cooling system.

⚠ CAUTION

**COOLING SYSTEM REQUIRES
SPECIAL FILL PROCEDURE**

- Open cab heater water valve by turning the cab temperature selector knob to "Heat" with ignition on.
- Open both cab heater valves on engine.
- Fill radiator to bottom of fill neck using 50/50 EG coolant mixture.
- If radiator is drained completely and refilled faster than 3 gpm (11.4 l/min), radiator may need to be topped off.
- Run engine at operating temperature for 5 minutes.
- Shut off engine.
- Wait until coolant is below 122° F. before removing cap to check coolant level.
- Top off cooling system if required.

Coolant should be changed periodically to eliminate the buildup of harmful chemicals. Drain and replace coolant every other detasseling season or 1,000 hours of operation, whichever occurs first. Refill with soft water only, as hard water contains minerals, which break down the anti-corrosion properties of the antifreeze.

Further Information

Refer to the engine manufacturer's operation manual for further information.

Engine Fuel

⚠ CAUTION

DIESEL FUEL CAN BE DANGEROUS

- Turn off engine before refueling.
- Do not smoke while refueling.
- Clear off any spilled fuel after refueling.

DIESEL

NOTE: Keep a fire extinguisher nearby when refueling.

DO NOT fill fuel tanks completely. Fuel can expand and run over. Wipe up all spilled fuel and clean with detergent and water before starting the engine.

Capacity

- 40 gallons (151 L)/each fuel tank

Type

- No. 2 diesel fuel recommended. (In operating conditions less than -32° F., use a blend of No. 1 and No. 2 diesel fuel).

NOTE: The addition of No. 1 diesel fuel may cause loss of power and/or fuel economy.

Priming

Refer to the engine manufacturer's operation manual for further information.

Filling the Fuel Tanks

1. Shut the engine off.
2. Remove fuel fill cap (located on top of fuel tank) and set aside.



Engine Fuel Fill
(Located on top of fuel tank
on each side of machine)
-Typical View

3. Fill tank to desired level.
4. Reinstall the fuel fill cap.
5. Repeat steps on opposite fuel tank.

Air Conditioning

NOTICE

Charge with R-134A only. Charge to 2.00 lbs 12 oz.

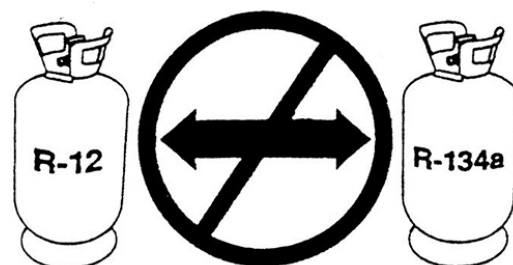

DO NOT MIX REFRIGERANTS

Recharging the AC System

The cab is equipped with an R-134A Air Conditioning System. **Recharge system with R-134A refrigerant only.**

NOTE: Confirm refrigerant before recharging the Air Conditioning System. If your system is mistakenly recharged with R-12 refrigerant, machine damage (such as compressor seizure) may result. If you do not have the proper equipment, it is recommended that you allow an authorized service technician to service your Air Conditioning System.

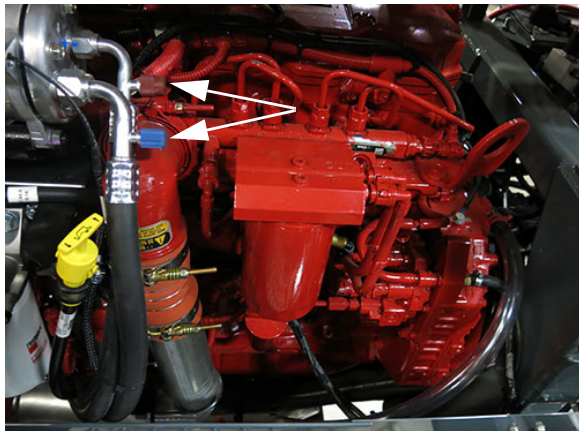

A/C Charge Ports
(Located on the left-hand side of machine - open hood panel to access)
-Typical View

NOTICE

Do not tap filter to remove dust. A crushed filter caused by tapping may result in engine damage. Remove and replace filter as recommended.



Engine Air Intake Filter
(Located near rear of machine - remove air cleaner end cap to access)
-Typical View

SERVICE - FILTERS

Engine Air Intake

IMPORTANT!

Do not change or remove filter unless Filter-Minder® indicates a blocked or plugged filter. Premature changing will allow unnecessary contamination to enter the engine and can result in engine damage or loss of power.

Never clean and re-install an air cleaner element. Hitting an element against any surface can result in damaged filter element and engine failure.

Any indications of cleaning or "tapping" a filter will void any engine warranties. Please refer to owner's manual for further information.

650367

Removal

The Engine Air Intake Filter should only be removed if replacement is required.

- Lift air cleaner latch, rotate cover, and remove end cap.
- Remove filter.

NOTE: Use care when removing the filter to ensure dust from the filter does not enter the air intake passage.

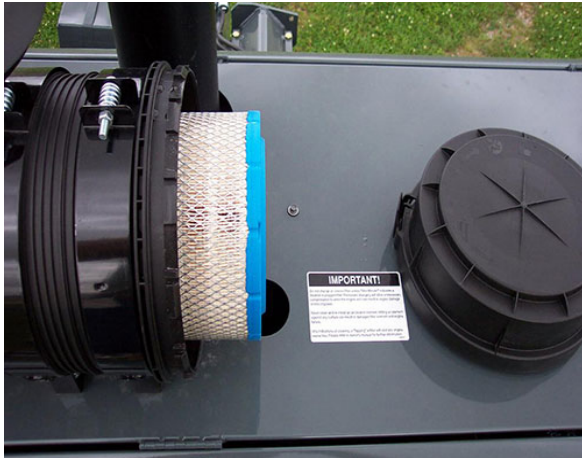

-Typical View

Replacement

Your machine is equipped with a Filter Minder® to notify you of filter element efficiency. Refer to the following Filter Minder service guidelines for further information.

Cleaning

It is not recommended to clean the Engine Air Intake Filter element. However, a clean damp cloth should be used to wipe away dust and debris from the air cleaner housing.

Filter Minder

The Filter Minder (located near the engine air intake filter housing) is an air restriction monitoring system that progressively and constantly indicates how much air filter capacity remains.

NOTE: Check Filter Minder reading daily.

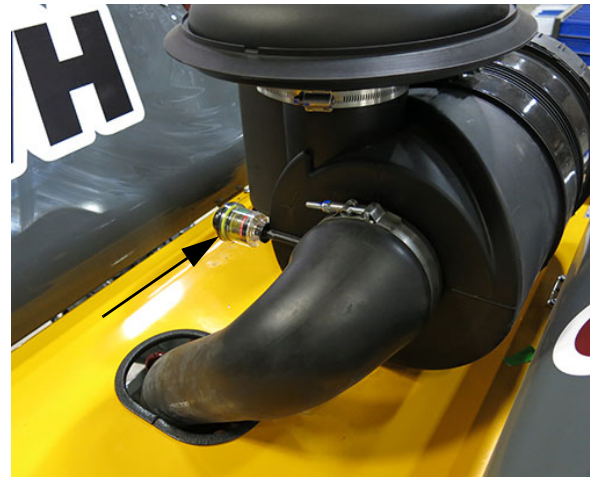

Filter Minder
(Located near engine
air intake filter housing)
-Typical View

Service

- Replace air filter when yellow indicator on the filter gauge reaches red line.
- Press the Reset Button (located on the Filter Minder) at each service.

Radiator Screens

<h2>NOTICE</h2>
Failure to keep cooling systems clean can cause overheating and damage to the engine and hydrostatic systems.

To maintain adequate airflow through the engine cooling system, the Radiator Screens must be inspected daily and cleaned as necessary.

Removal

- **Side Grille Screen** - Slide grille screen out of housing (located on side of radiator) to remove.

Cleaning



Side Grille Screen
(Slide out of radiator housing to remove)
-Typical View

- **Top Grille Screen** - Remove two bolts (located on top radiator panel) and set aside. Remove panel to access screen.

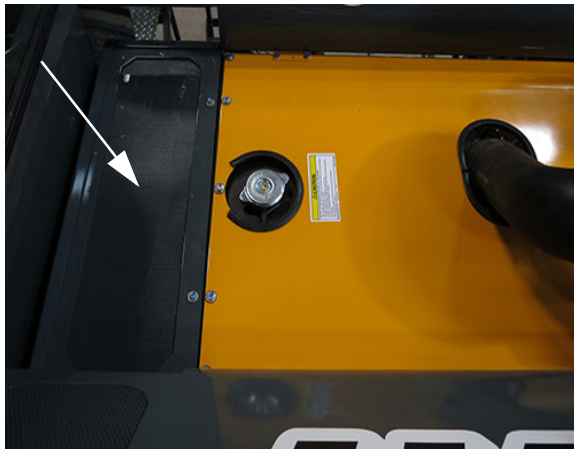

Top Grille Screen
(Remove two radiator panel bolts and panel to access)
-Typical View

NOTICE

Use care when cleaning the cooling fins of the radiator, oil cleaner, and A/C condenser with compressed air or water. Failure to comply may result in damage to the cooling fins and impair cooling capabilities.

Use compressed air to dislodge large debris and dirt. Water from a pressurized hose may also be used. If necessary, screens may be soaked in warm, soapy water and scrubbed gently with a brush.

Engine Oil Filter

The Engine Oil Filter (located on the right-hand side of engine - open hood panel to access) should be replaced every 250 hours of operation or whenever the oil is changed, whichever occurs first.

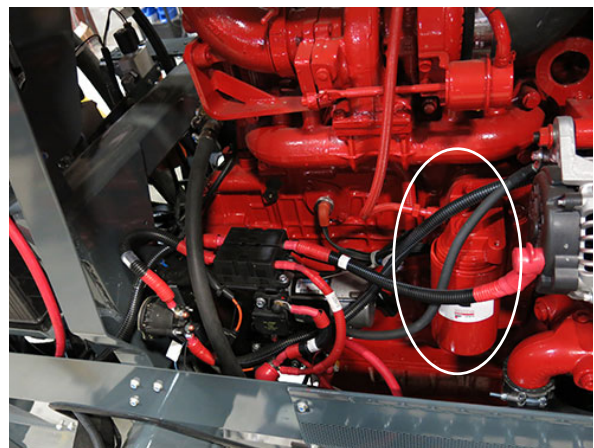

Engine Oil Filter
(Located on the right-hand side of engine - open hood panel to access)
-Typical View

Fuel Filters

Primary Fuel Filter (Water Separator)

The Primary Fuel Filter (located on the left-hand side of engine - open hood panel to access) should be drained of water and other

SECTION 8 – MAINTENANCE AND STORAGE



deposits daily. Replace the filter every 500 hours of operation or yearly, whichever occurs first.

Secondary Fuel Filter

The Secondary Fuel Filter (located on the left-hand side of engine - open hood panel to access) should be replaced every 500 hours of operation or yearly, whichever occurs first.

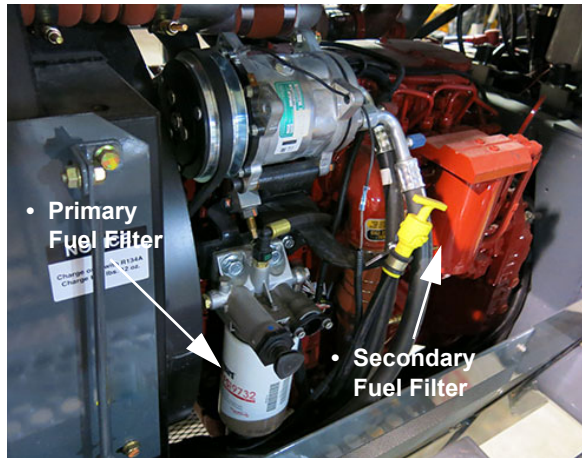

Primary and Secondary Fuel Filters
(Located on the left-hand side of engine - open hood panel to access)
-Typical View

Hydraulic Filters

NOTICE

Use of incorrect filter micron rating may result in system damage and will void the warranty.

Charge Pressure Filter

- Remove the Charge Pressure Filter (located on the rear left-hand side of machine - open hood panel to access) and replace with a new 4 micron-rated Charge Pressure Filter every 500 hours of operation or yearly, whichever occurs first.

Return Filter

- Remove the Return Filter (located inside the return filter housing on top of the

hydraulic oil reservoir - remove cover to access) and replace with a new 25 micron-rated Return Filter every 500 hours of operation or yearly, whichever occurs first.

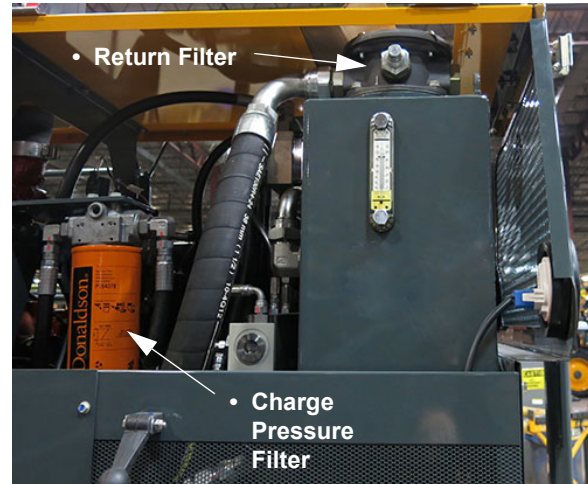

Charge Pressure and Return Filters
(Located near the rear left-hand side of machine)
-Typical View

High Pressure In-Line Filter

Lift/Dump Valves

Lift Control System Valves are protected by a 90 Micron In-Line Sintered Bronze Filter (located beneath machine - lower front screen panel to access).

NOTE: Replace High Pressure In-Line Filter if required. Contact your John Deere dealer for assistance.

Filter Access

1. Remove the two (2) Securement Pins (located on the front screen panel) and set aside.



Screen Panel Securement Pins
(Located on front screen panel)
-Typical View

2. Lower screen panel to access filter.



High Pressure In-Line Filter
(Located beneath machine - lower
front screen panel out to access)
-Typical View

Fresh Air Cab Filters

-If Equipped

*(Refer to your Parts Manual for specific
location and replacement part numbers)*



Fresh Air Cab Filter Access
(Located in cab headliner)
-Typical View

Paper Filter (1)

- Remove the Paper Filter and gently tap it against a flat surface.
- Direct low-pressure compressed air through the filter to remove large particles.
- Replace the Paper Filter, if necessary.

NOTE: The Paper Filter should be cleaned yearly, or as required.

Charcoal Filter (2)

- Remove and replace the Charcoal Filter at the first sign of chemical odor entering the cab.

Recirculating Filter (3)

- Clean the Recirculating Filter with soap and water yearly, or as required.
- Replace Recirculating Filter if it becomes worn.

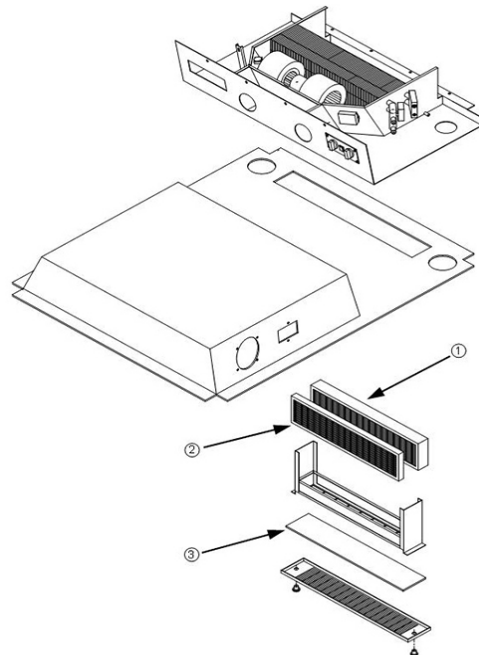

Fresh Air Cab Filters

- (1) - Paper Filter
 - (2) - Charcoal Filter
 - (3) - Recirculating Filter
- Typical View

SERVICE - LUBRICATION

NOTICE

Failure to properly lubricate pivot and friction points may result in unnecessary wear and damage.

NOTICE

Mobilgrease XHP™ 222 (complying with NLGI 2, EP, ISO 220 specifications) recommended.

Leg Bearings

The leg assemblies on your machine are constructed with upper and lower nylon bearings for suspension telescoping between the inner and outer leg weldments. These bearings must be lubricated to avoid bearing failure and ensure optimal ride quality.

Grease Points (zerks) are located on the sides of the leg assemblies - one on the upper bearing, and two on the lower bearing. Refer to following illustration.

NOTE: Grease front and rear leg bearings daily.

During operation, grease may possibly be wiped away due to the passing of crop leaves. Therefore, leg bearings should be greased a minimum of two (2) times per day (e.g. morning and noon).

NOTE: If the crop is mature enough or plant population is high enough, more frequent leg bearing grease application may be required to ensure proper lubrication and optimal performance.

Torque Hub® Seal Boot

Each leg assembly has a Torque Hub Seal Boot (located between the wheel motor and Torque Hub). Grease Seal Boot every 50 hours of operation, or as needed.

NOTE: An over-greased Seal Boot will leak grease out around the seal, and when heated, may cause the appearance of a failed wheel motor leaking hydraulic fluid. Wipe away any excess grease after servicing.

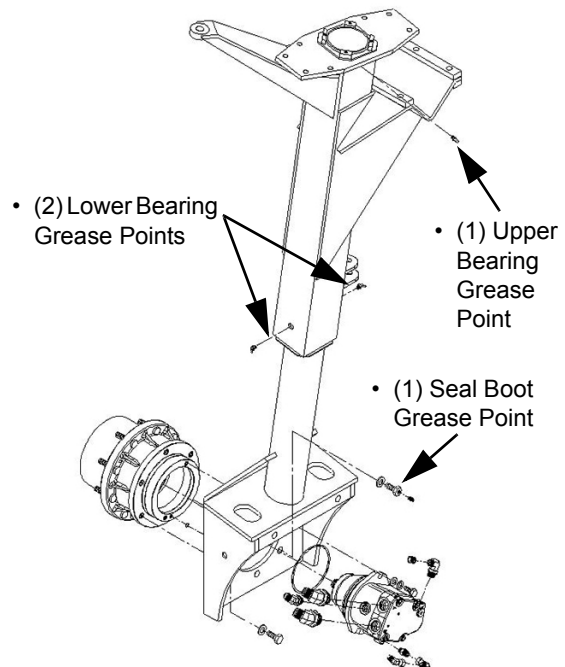

Leg Bearing and Torque Hub Seal Boot Grease Points
-Typical View

Tread Adjust Bearing Slide Path

NOTICE

Failure to inspect and lubricate the tread adjust bearing slide path may cause one of the legs to “hang up” while the other is still sliding during adjustment. Failure to comply may result in machine damage.

- Inspect slide path often and lubricate as needed.

NOTE: Generously apply a standard lubricant to the slide path.

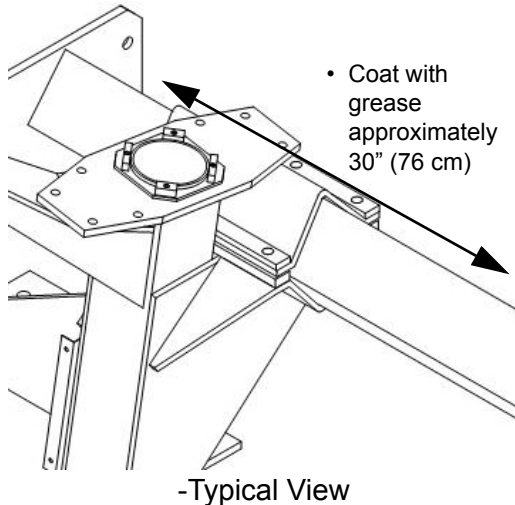

NOTE: During late season crop applications, the grease may possibly be wiped away due to the passing of crop leaves. More frequent grease application may be required to ensure proper lubrication and optimal performance.

Quad Puller Heads

- Lubricate each Quad Puller Head grease zerk (4 - two each side) twice per day (morning and noon suggested).



Quad Puller Head
-Typical View

Outrigger Fold (Left and Right)

- Lubricate each left and right Outrigger Fold grease zerk (2) a minimum of every 50 hours of operation, or as needed.

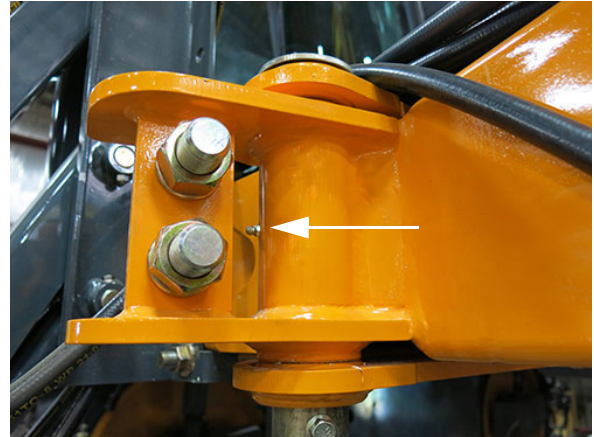

Outrigger Fold
-Typical View

Lift Arm Assemblies

- Lubricate each Lift Arm Assembly grease zerk (6) a minimum of every 50 hours of operation, or as needed.

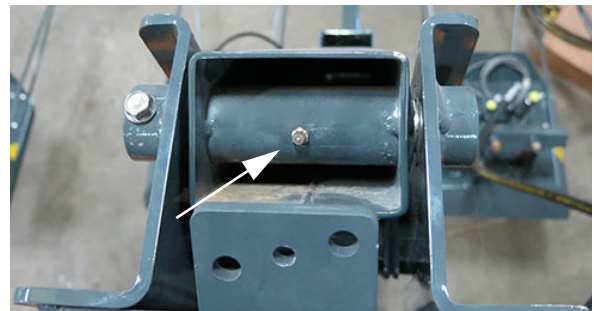

Lift Arm Assembly - Top
-Typical View



Lift Arm Assembly - Mid
-Typical View

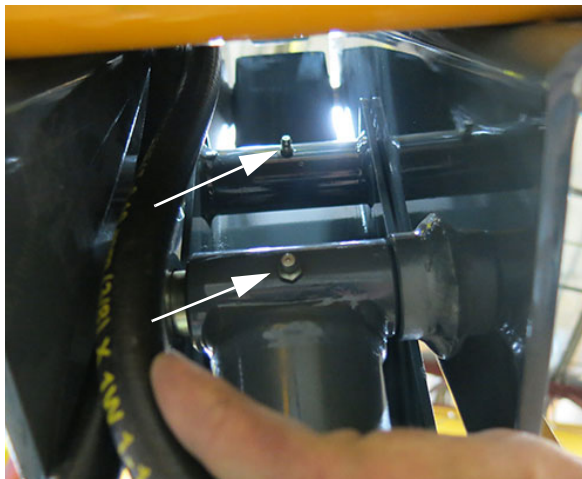

Lift Arm Assembly - Inner Arm
-Typical View

NOTE: An additional grease zerk is located inside of the lower lift arm frame.

SERVICE - BELTS

Engine Drive Belt

Removal

- Insert a 3/8" square ratchet drive into the belt tensioner.
- Lift UP and remove the Engine Drive Belt.

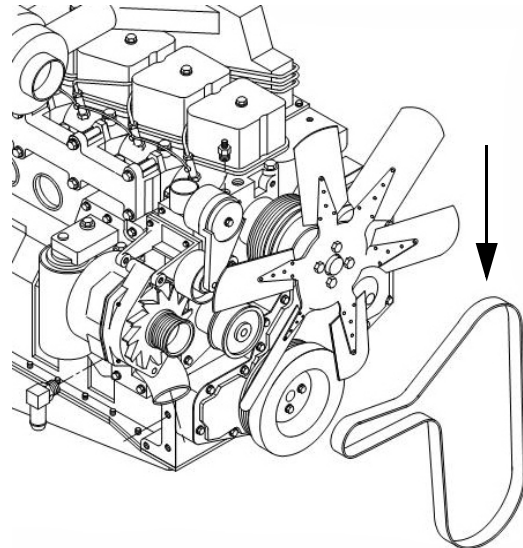

-Typical View

Inspection

- Visually inspect the Engine Drive Belt daily.
- Check the belt for intersecting cracks.

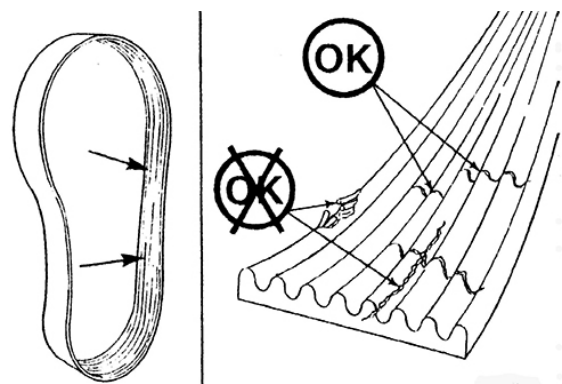

-Typical View

NOTE: Transverse cracks (across the belt width) are acceptable. Longitudinal cracks (direction of the belt length) that intersect with transverse cracks are not acceptable.

- Replace the Engine Drive Belt if it becomes frayed or has material missing.

A/C Compressor Belt

-If Equipped

Visually inspect the A/C Compressor Belt daily. Replace the belt if it becomes frayed or has missing material.

- To tighten the A/C Compressor Belt, loosen the two Pivot Bolts and the two Slide Bolts.

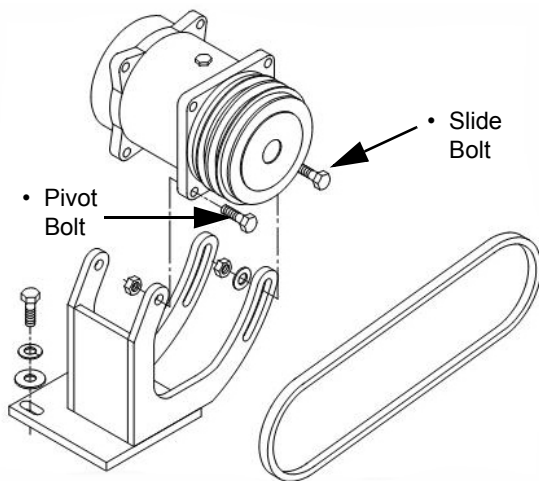

-Typical View

- Using a pry tool, adjust the tension of the A/C Compressor Belt to desired tautness.
- While maintaining tension, re-tighten all four bolts.

SERVICE - BOLT TORQUE

NOTICE

Check lug nut torque immediately after receiving the machine and every 50 hours of operation thereafter.

NOTICE

To achieve even torque consistency, the tire should be completely off the ground.

Wheel Bolts

NOTE: If you do not have the proper equipment to mount a tire, contact a local qualified tire service center.

The tire should be mounted on the rim (as shown in the following illustration) for optimal traction and tread cleaning action.



-Typical View

To install wheel/tire assembly on the Torque Hub®:

1. Ensure threads are thoroughly cleaned of rust and dirt.

NOTE: Threads should be dry (no lubricant).

2. Align the wheel bolt holes with the Torque Hub studs.
3. Mount wheel on the hub.
4. Start all of the lug nuts and tighten until snug.
5. Following the torque sequence (as shown in the following illustration), turn each lug nut to a torque value of 120 dry ft.-lbs.

NOTE: Use slow, even pressure on the torque wrench. Quick or jerky movements can cause inaccurate values.

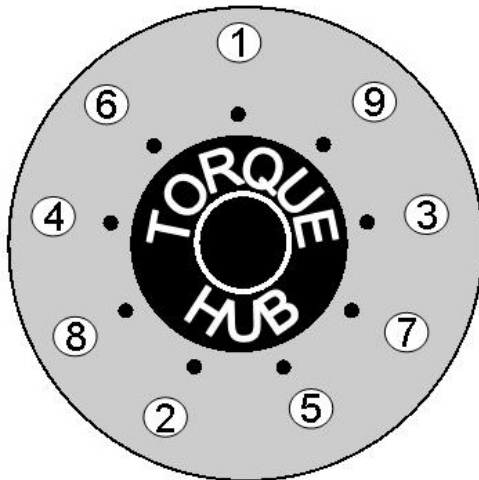

Torque Sequence

- Repeat the same sequence to 150 dry ft.-lbs., and again to 180 dry ft.-lbs.

NOTE: If the wheel turns during lug nut torquing, lower machine to the ground - just enough for the tire to touch and prevent rotation. Or, more preferably, place a suitable wedge between the tire and the ground. Lower the machine and resume operation. Recheck torque after 30 minutes of operation.

- When torquing is complete, lubricate exposed threads with anti-seize compound.

Leg Mounting Bolts

NOTE: Check Leg Mounting Bolt torque daily.

⚠ CAUTION

Never remove more than three leg mounting bolts from any single leg mount.

To torque leg mounting bolts:

- Start lug nuts on the mounting bolts and tighten until snug.
- Following the torque sequence (as shown in the following illustration), turn each lug nut to a value of 100 dry ft.-lbs.

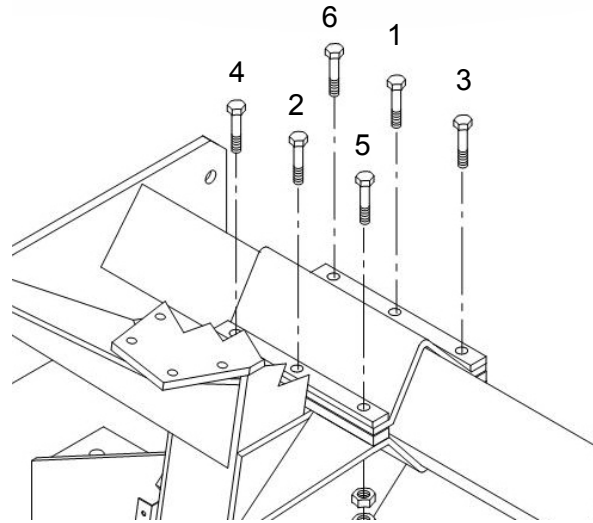

NOTE: Use slow, even pressure on the torque wrench. Quick or jerky movements can cause inaccurate values.

- Lower machine to the ground and repeat same sequence to 130 dry ft.-lbs., and again to 160 dry ft.-lbs.
- Resume operation and recheck torque values after 30 minutes.

SERVICE - TOE-IN

Toe-In Adjustment

NOTE: Toe should be set with the machine in the "run" position and the air bags set.

To adjust Toe-In of the front tires, perform the following for both front steering cylinders:

- Remove Cotter Pin, Castle Nut, and Lock Washer from the steering cylinder assembly.

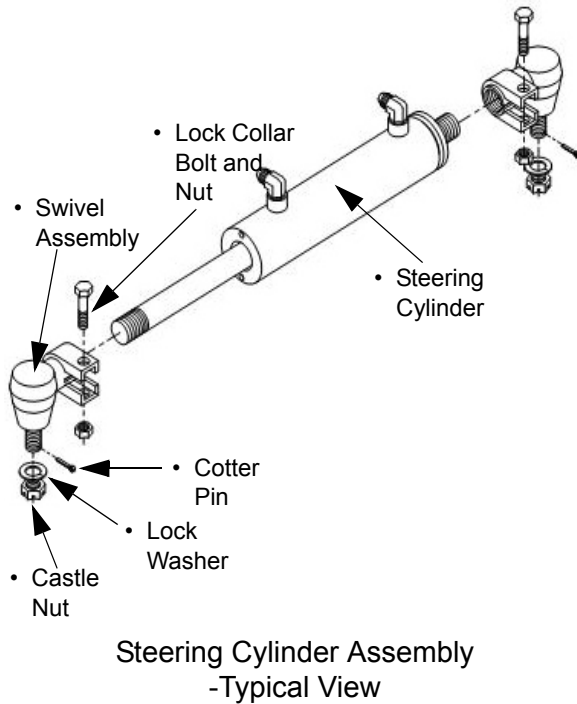

2. Loosen the Lock Collar Bolt and Nut.
3. Lightly tap Swivel Assembly out of steering arm.
4. Move left and right tires evenly until the difference in Dimensions A and B are within specified range. See following illustration.

NOTE: Dimension A should be 1/2 - 3/4" (1.3 - 1.9 cm) less than Dimension B.

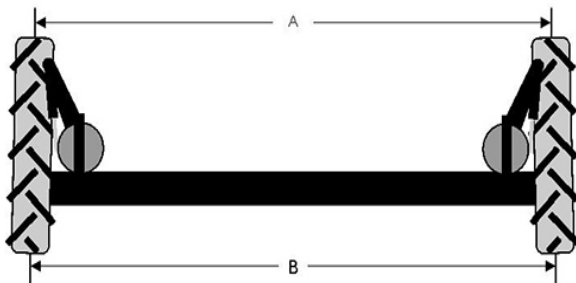

5. Screw Swivel Assembly IN or OUT on the Steering Cylinder until the tread part lines up with the steering arm.
6. Insert Swivel Assembly back into steering arm.
7. Reinstall Lock Washer and Castel Nut, then tighten.
8. Reinstall Cotter Pin.
9. Tighten Lock Collar Bolt.

To Gauge Toe-In

1. Use a tape measure placed at one-half tire height on the front center seam of the front tire, compared to the same measurement of the rear of the front tire.
2. Subtract the front measurement from the rear measurement (which must be a positive number).
3. Correct Toe-In should range between 1/2 - 3/4" (1.3 - 1.9 cm).

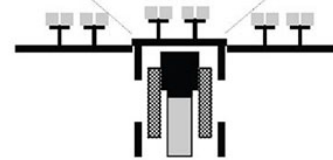
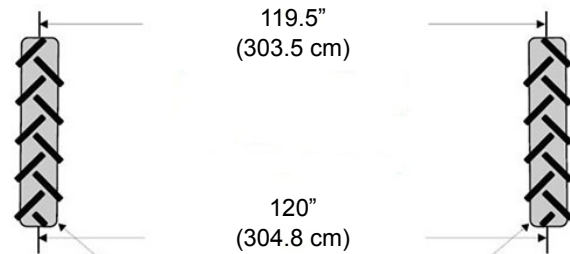

Example of correct Toe-In for a machine with 120" tread width

NOTE: Must have 1/2 - 3/4" (1.3 - 1.9 cm) Toe-In.

NOTE: Toe-in is factory preset and should not require adjustment unless the steering cylinders are removed or if you experience difficulty steering one way versus the other.

Contact your John Deere dealer for additional assistance regarding Toe-In measurement and adjustment.

SERVICE - AIR SPRINGS

-If Equipped

Air Ride Adjustment



NOTE: Visually inspect the height of each air bag daily. Measure height of each air bag (using a tape measure) every 50 hours of operation. Adjust as necessary.

1. Park the machine on level ground with outriggers in the completely UNFOLDED and field operating position.
2. Adjust the air pressure in each Air Bag until the distance between the bottom of the Steering Plate (1) and the top of the Bumper Pad Strike Plate (2) is six (6) inches (15.2 cm). See following illustration.

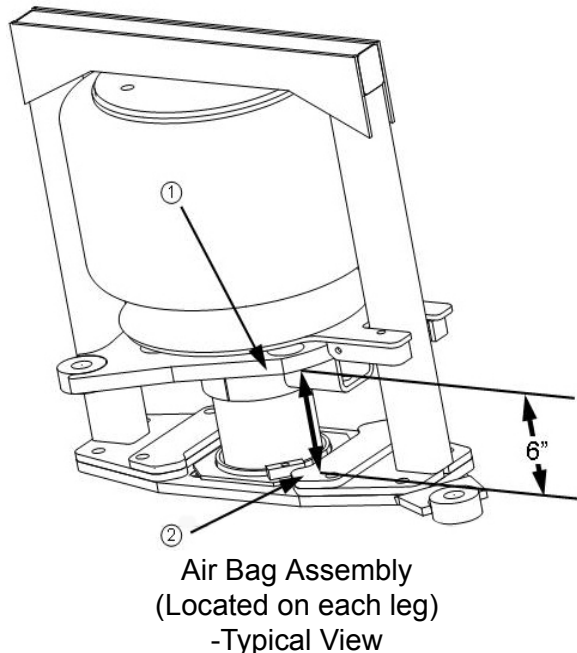

3. With a clear path on level ground, drive the machine forward 100 yards (91.4 m), cycling the steering back and forth, and shifting machine weight from side to side.
4. Stop on level ground and re-measure. Adjust as necessary.
5. Repeat procedure until desired measurement is achieved.

The amount of pressure in the Air Bags will depend on the options available on the machine. Typically, pressure should be approximately 42 psi/2.9 bar (front) and 24 psi/1.7 bar (rear).

The pressure should be enough that the tie rods and steering cylinders are level, as shown in the following photo.



-Typical View

NOTE: Over-inflated or under-inflated Air Bags will cause stress to the machine, resulting in damage.

SERVICE - MISCELLANEOUS

A/C System Receiver/Drier

The A/C System Receiver/Drier (located behind cab near the radiator - remove radiator screens to access) should be replaced if the A/C loop is ever open (e.g. when replacing a compressor or condenser line, etc.)

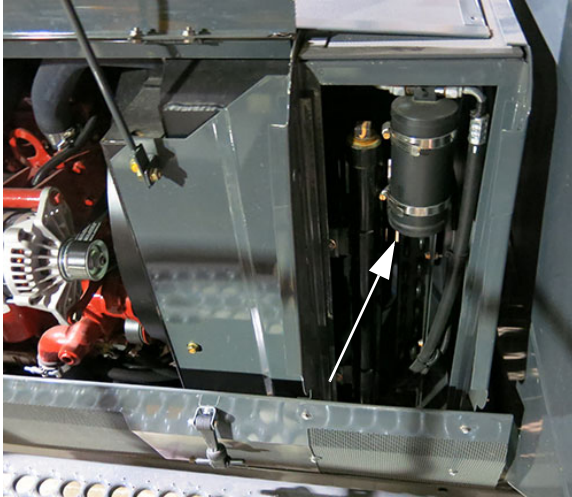

A/C System Receiver/Drier
(Located behind cab near the radiator -
remove radiator screens to access)
-Typical View

Tire Pressure

⚠ CAUTION

When inflating tire, use an extension with an in-line air gauge and air chuck. This will allow the operator to stand clear of a possible tire sidewall explosion trajectory.

- Check tire pressure weekly.
- Never inflate a tire more than the recommended maximum air pressure.
- Use an airline with a locking air chuck and stand behind the tire tread while filling.



-Typical View

NOTE: Tire pressure will depend on type of tire used and amount of load.

Wiper Blade

-If Equipped

NOTICE

Use a sturdy stationary ladder to safely access the wiper blade.

Do not allow the Wiper Blade to run on a dry windshield, as this will shorten the life of the blade and/or cause scratching on the windshield.

NOTE: Replace the windshield wiper blade (39"/99 cm) as necessary.

Washing the Machine

As often as possible, thoroughly wash the machine and apply paint to any place where the paint is light or missing.

For replacement decals or touch-up paint recommendations, contact your local John Deere dealer.

SERVICE INTERVALS

Service Point	Initial	Daily/ Before Each Use	As Required	50 Hrs.	100 Hrs.	250 Hrs. **	500 Hrs. **	1000 Hrs.
Check Lug Nut Torque (Break-in)	X							
Check Engine Oil Level		X						
Check Radiator Coolant Level		X						
Check Radiator Grille Screens		X						
Check Engine Drive Belt		X						
Check A/C Compressor Belt		X						
Check Filter Minder® Level		X						
Check Hydraulic Reservoir Level		X						
Check Battery		X						
Check for Leaks Around the Machine		X						
Check Windshield Washer Fluid Level (if equipped)		X						
Check and Drain Primary Fuel Filter (Water Separator)		X						
Check Quad Puller Tire Pressure		X						
Check/Tighten Cutter Blade Retaining Bolt		X						
Lubricate Quad Puller Head Grease Zerks (4 each)		X						
Check Leg Mount Bolt Torque		X						
Check Air Bags (visual)		X						
Lubricate Quad Puller Head Bearings		X						
Grease Leg Lubrication Zerks		X						
Replace Windshield Wiper Blade (if equipped)			X					



SECTION 8 – MAINTENANCE AND STORAGE

Service Point	Initial	Daily/ Before Each Use	As Required	50 Hrs.	100 Hrs.	250 Hrs. **	500 Hrs. **	1000 Hrs.
Fill Windshield Washer Fluid Reservoir (if equipped)			X					
Clean Radiator Grille Screens			X					
Change Engine Drive Belt			X					
Change A/C Compressor Belt			X					
Charge A/C Compressor *			X					
Change Air Intake Filter (Filter Minder)			X					
Replace High-Pressure In-Line Filter			X					
Change Battery			X					
Replace Fuses and Circuit Breakers			X					
Replace Cab Charcoal Filter (if equipped)			X					
Clean Cab Fresh Air (Paper) Filter (if equipped)			X					
Clean Cab Recirculation Filter (if equipped)			X					
Check Tire Pressure			X					
Lubricate Hydraulic Tread Adjust Bearing Slide Path			X					
Adjust Air Bag Suspension Height			X					
Change Air Dryer Cartridge			X					
Check Air Bags (measure)				X				
Check Lug Nut Torque				X				
Change Wheel Hub Oil (Break-in)				X				
Lubricate Torque Hub® Grease Zerk/Seal Boot				X				
Lubricate Left/Right Outrigger Fold Grease Zerks				X				
Lubricate Lift Arm Assembly Grease Zerks (6 each)				X				
Check Wheel Hub Oil Level					X			

SECTION 8 – MAINTENANCE AND STORAGE



Service Point	Initial	Daily/ Before Each Use	As Required	50 Hrs.	100 Hrs.	250 Hrs. **	500 Hrs. **	1000 Hrs.
Clean Battery					X			
Change Engine Oil Filter						X		
Change Engine Oil						X		
Change Wheel Hub Oil						X		
Pack Bearing on Non-Drive Quad Puller Tire Hub						X		
Change Charge Pressure Filter							X	
Change Hydraulic Return Filter							X	
Change Primary Fuel Filter (Water Separator)							X	
Change Secondary Fuel Filter							X	
Check Radiator Coolant Concentration							X	
Change Hydraulic Reservoir Oil							X	
Change Radiator Coolant								X

* Use proper equipment.

** 250-500 hours or yearly, whichever occurs first.

STORAGE

Preparing For Storage

1. Perform daily level checks, lubrication, and bolt/linkage inspections, as required in this manual.
2. Every other season, drain the coolant from the engine and radiator. Probe the drain holes during drainage to ensure they are not clogged by sludge, scale, or other deposits.
Fill the cooling system to the top with a 50/50 water/antifreeze mixture. Run the engine to operating temperature and recheck level.
3. Add a fuel stabilizer to the fuel and fill the tank.
4. Run the engine until it reaches operating temperature, then drain the engine oil. Refill with fresh oil of recommended weight and install a new lubricating oil filter element.
5. With the engine at normal operating temperature, cycle all hydraulic functions, including the steering.
6. Release tension on all belts.
7. Use plastic bags and water-resistant adhesive tape to seal the air intake opening, all exhaust manifold openings, engine oil filter cap, hydraulic oil tank breather cap, and fuel tank caps.
8. Turn the Battery Disconnect Switch OFF.
9. Disconnect and remove batteries. Completely clean and charge the batteries. Coat the terminals with dielectric grease.

and store the batteries in a cool place (above freezing).

10. Thoroughly wash the machine. Touch up any painted surfaces that are scratched or chipped.

NOTE: For paint touch-up recommendations, contact your local John Deere dealer.

11. Replace worn or missing decals. Refer to “Safety Decals” provided in the *Safety and Precautions Section* for proper location of warning decals and corresponding part number.

NOTE: For decal replacement, contact your local John Deere dealer.

12. Apply multi-purpose grease to coat exposed hydraulic cylinder rods to prevent rusting, which could result in cylinder damage.
13. If the machine must be stored outside, cover with a waterproof cover.

6. Thoroughly clean the machine and it's attachments.
7. Perform all recommended services as instructed elsewhere in this section.
8. For starting instructions, refer to “Engine - Starting” provided in the *Engine and Drive Systems Section* elsewhere in this manual.

Removing From Storage

NOTICE

Protective compounds such as grease can harden under exposure to weather conditions. Be sure to remove any dried grease and reapply new, if necessary.

1. Inspect the condition of and test the air pressure of all tires.
2. Carefully unseal all openings that were previously sealed in the “Preparing for Storage” process.
3. Clean and reinstall the batteries. Be sure to attach the battery cables to the proper terminals.
4. Tighten all belts. Inspect and replace any worn belts.
5. Check the engine oil, hydraulic oil, and engine coolant levels, and add if necessary.

NOTE: A mixture of 50/50 water/antifreeze will cool adequately in the summer, as well as protect in winter.



SECTION 9 – MISCELLANEOUS

TRANSPORTING

When driving on a public roadway or elsewhere, be aware of any situation where the machine will be passing under an object with a clearance lower than the transporting height of the machine.

⚠ WARNING

When transporting the detasseler, observe the following to avoid serious injury or death:

- Check for adequate clearance before driving under any overhead obstructions.
- Contact with power lines may result in serious injury or death.

⚠ WARNING

- Loading the detasseler onto a trailer may result in machine rollover.
- Stopping the detasseler on trailer ramps may result in machine rollover.

⚠ CAUTION

Ensure the outriggers are in the folded and locked position before transporting the machine. Failure to comply may result in personal injury or equipment damage.

Folding the Outriggers

Manual Fold

To unfold (extend) the outriggers:

1. Remove the two Securement Pins (installed on the Lock Bar Mounting Bolts

- located on the outrigger and center tool bar) and set aside.

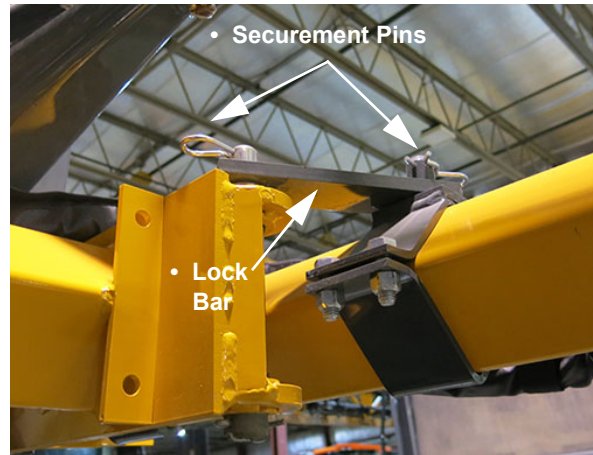

Securement Pin/Lock Bar Assembly
(Located between the outrigger and center tool bar)
-Typical View

2. Remove Lock Bar and set aside.
3. Unfold outrigger to the fully extended position.
4. With the outrigger fully extended, install the provided Ratchet Bar onto the outrigger and center tool bar mounting bolts.



Ratchet Bar Installation
-Typical View

5. Reinstall the Securement Pins (that were removed in Step 1) to the Ratchet Bar Mounting Bolts.

NOTE: The Ratchet Bar should not be used in place of the Lock Bar during transportation.

- Repeat Steps 1 through 5 on opposite side of machine.

To fold (retract) the outriggers:

- Remove the Securement Pins and Ratchet Bar and set aside.
- Fold outrigger to the fully retracted position.
- Reinstall Lock Bar and Securement Pins to the Lock Bar Mounting Bolts.
- Repeat Steps 7-9 on opposite side of machine.

Hydraulic Fold

-If Equipped

The Hydraulic Fold feature is controlled by a Hydraulic Fold Valve (located on the center tool bar) and Hydraulic Fold Cylinders (attached to the outrigger and center tool bar). Hydraulic Outrigger Fold Switches (located on the side console) are used to unfold/fold the outriggers.



Hydraulic Fold Valve
(Located on center tool bar)
-Typical View



Hydraulic Fold Cylinder
(Attached to outrigger and center tool bar)
-Typical View

To unfold (extend) the outriggers:

- Remove the two Securement Pins (installed on the Lock Bar Mounting Bolts - located on the outrigger and center tool bar) and set aside.

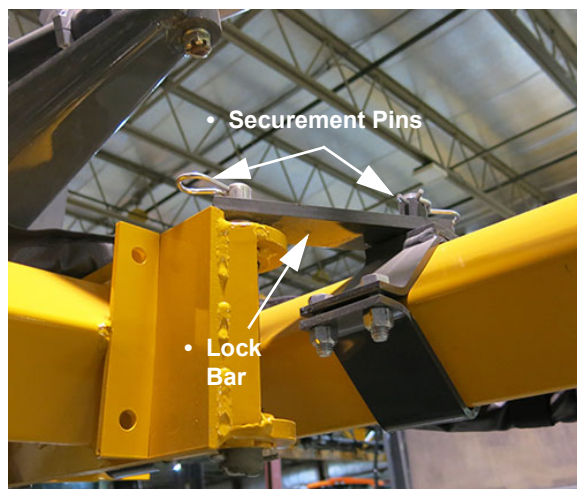

Securement Pin/Lock Bar Assembly
(Located between the outrigger and center tool bar)
-Typical View

- Remove Lock Bar and set aside.
- Remove Securement Pins and Lock Bar on opposite side of machine.
- Press and hold the corresponding Right or Left Hydraulic Outrigger Fold Switch in the OUT position until the outriggers are fully extended.



Hydraulic Outrigger Fold Switches
(Located on the side console)
-Typical View

5. With the outriggers fully extended, install the provided Ratchet Bar onto the outrigger and center tool bar mounting bolts.



Ratchet Bar Installation
-Typical View

6. Reinstall the Securement Pins (that were removed in Step 1) to the Ratchet Bar Mounting Bolts.

NOTE: The Ratchet Bar should not be used in place of the Lock Bar during transportation.

7. Install Ratchet Bar and Securement Pins on opposite side of machine.

To fold (retract) the outriggers:

8. Remove the Securement Pins and Ratchet Bar (on both sides of machine) and set aside.
9. Press and hold the corresponding Right or Left Hydraulic Outrigger Fold Switch in the IN position until the outriggers are fully retracted.
10. Reinstall Lock Bar and Securement Pins to the Lock Bar Mounting Bolts (on both sides of machine).

Driving the Detasseler on a Public Roadway

1. Ensure the outriggers in the FOLDED and LOCKED position when driving or transporting the machine.
2. Use the flashing hazard/warning lights, day or night to warn other drivers, unless prohibited by law.
3. Know and obey all state laws for driving agricultural equipment on a public roadway.
4. Adjust machine speed to suit the conditions.
5. Slow down and use turn signals before turning.
6. Pull over to the side of the road before stopping.
7. Keep a proper lookout and maintain control of the machine.
8. Do not drive under trees, bridges, wires, or other obstructions unless there is adequate clearance.
9. Use extra care when entering or exiting a public roadway.
10. Ensure the SMV (Slow Moving Vehicle) emblem is properly displayed to warn other drivers, unless prohibited by law.

Loading

 **WARNING**

Keep all persons away from trailer when loading or unloading the detasseler. Failure to comply may result in serious injury or death.

NOTICE

Read and understand the trailer manufacturer's operation manual. Hitch the trailer to the pulling vehicle according to their recommendations.

NOTICE

The loaded height and width of the trailer must conform to state law in which it is being used. Do not exceed the trailer manufacturer's recommendations on loaded weight.

1. Pull the trailer to flat ground.
2. Engage the pulling vehicle's parking brake and turn the engine OFF.
3. Use tire chocks to keep the trailer from moving.
4. Fold the outriggers in and lock them in place.
5. Lower the trailer ramps and set the ramp spacing for the machine's tread width setting.
6. Have an attendant help guide you onto the trailer.

NOTE: Keep all person(s) away from the trailer when loading the detasseler.

7. Allow enough room between the detasseler and the pulling vehicle for turning.
8. Secure the detasseler onto the trailer using the recommended securement restraints (see trailer manufacturer's operation manual).
9. Cover or remove the SMV (Slow Moving Vehicle) emblem when traveling over 25 mph (40 km/h).

Unloading

1. Pull the trailer to flat ground.
2. Engage the pulling vehicle's parking brake and turn the engine OFF.
3. Use tire chocks to keep the trailer from moving.

4. Lower the trailer ramps and set the ramp spacing for the machine's tread width setting.
5. Carefully release the securement restraints.
6. Have an attendant help guide you off of the trailer.

NOTE: Keep all person(s) away from the trailer when unloading the detasseler.

7. Uncover or replace the SMV (Slow Moving Vehicle) emblem.

Towing

Hagie Manufacturing Company does not recommend towing the detasseler. Should a situation arise where towing is unavoidable, use extreme caution when performing the following:

WARNING

The detasseler's braking power will become disabled after the Torque Hubs have been disengaged. Use extreme caution.

1. Ensure the outriggers are in the FOLDED and LOCKED position.
2. To disengage the Torque Hubs, remove the two (2) outer cap bolts (located on the center of each wheel hub).



Cap Bolts
-Typical View

SECTION 9 – MISCELLANEOUS



- Reverse cover and replace cap bolts.

NOTE: This process applies pressure on a spring-loaded splined shaft, disengaging the Torque Hub. Failure to disengage the Torque Hubs may result in damage to the wheel motors, hubs, or brakes.

CAUTION

When re-engaging the Torque Hubs, ensure the spring-loaded splined shaft has returned to its expended position.

When towing, it is necessary that two vehicles of sufficient size and weight are used for adequate pulling and braking. One of the vehicles is used for pulling the detasseler, and the second vehicle is used for braking, should the detasseler overtake the towing vehicle (such as when going downhill).

WARNING

Secure items (e.g. tow straps, chains, etc.) between the towing vehicle, braking vehicle, and detasseler to avoid possible dislodgement.

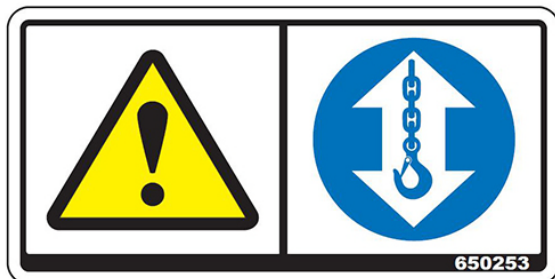

TOW POINT

- Attach adequate length chains to the specified tow points (located on each leg).

NOTE: Ensure chains are installed in such a way that they will not slip off.



Tow Point
(Located on each leg)
-Typical View

- Attach the front chains to the towing vehicle, and the loose end of the rear chains to the braking vehicle.

NOTE: Refer to the towing vehicle operator's manual to determine the safest attachment point for the vehicle.

NOTICE

Excessive speed may result in damage to the Torque Hubs and Hydrostatic System. Do not exceed 3 mph (4.8 km/h) when towing the detasseler.

NOTE: The machine must be running to enable power steering functions.

- Turn the Hazard/Warning Lights ON.
- Place SMV emblem so it is visible from the rear of machine.
- Reduce towing speed well in advance of any anticipated turns.
- Know and obey all state laws for towing agricultural equipment on public roadways.

NOTE: Do not tow the machine long distances. Do not use towing as a way of transporting the machine between fields. Towing should only

be used as a last resort in any situation, as damage may occur to the machine.

Contact your John Deere dealer for additional towing assistance.

ATTACHMENTS - ASSEMBLY AND INSTALLATION

NOTICE

Read and comply with the following attachment instructions. Ensure you have the proper equipment and assistance when installing an attachment.

⚠ CAUTION

Engage the parking brake and turn the engine OFF before installing components.

In shipment, some machine components may have been sent loose and require installation before operating.

To ensure proper component installation, refer to your Parts Manual for outlining the installation, hydraulic schematic, and wiring diagrams.

NOTE: Refer to your Parts Manual for correct hardware when performing the following attachment procedures.

Outrigger Assembly

1. Attach the center tool bar to the front frame cross-member (with supplied hardware).

NOTE: The guide pin (that is welded to the outrigger mount) is located toward the bottom of the assembly.

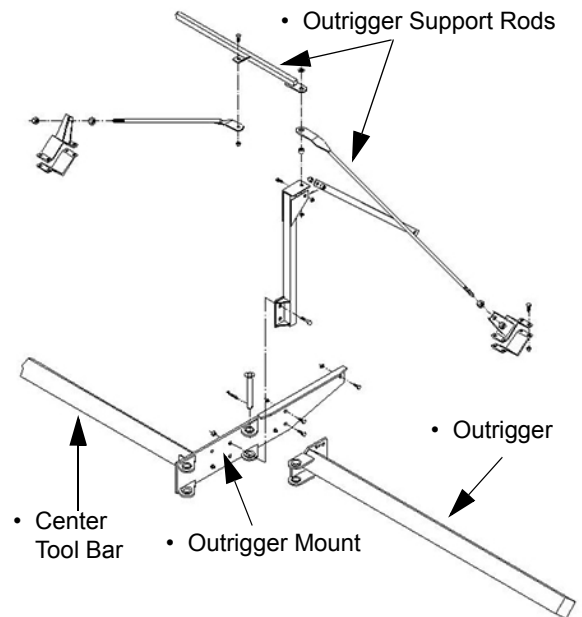

2. Attach left and right outrigger (with supplied hardware).
3. Attach outrigger support rods, if required.

Lift Arm Assembly

1. Attach the hoist column adapters to the tool bar and the outriggers at the recommended spacing.

NOTE: Refer to your Parts Manual for spacing recommendations.

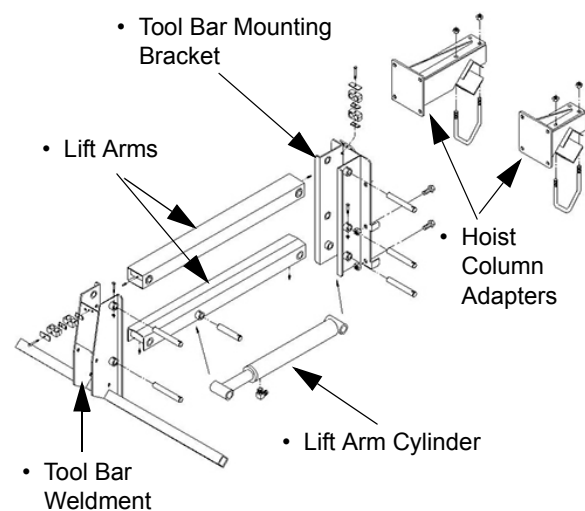

2. Attach tool bar mounting bracket to the hoist column adapters.

SECTION 9 – MISCELLANEOUS



3. Attach the lift arms to the tool bar mounting bracket.
4. Attach lift arm cylinders to the lift arms.
5. Attach tool bar weldment to the lift arms.
6. Connect hydraulic hoses to the lift cylinders.

NOTE: Refer to your Parts Manual for correct hydraulic schematics.

Cutter Head Assembly



CAUTION

SEVERING OF FINGERS OR HAND.
DO NOT PLACE FINGERS OR HAND NEAR A MOVING CUTTER BLADE, ATTEMPT TO STOP A MOVING CUTTER BLADE, OR PERFORM MAINTENANCE NEAR A MOVING CUTTER BLADE.

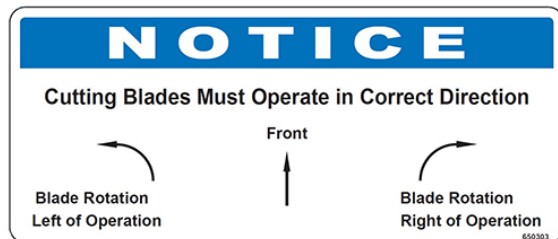

NOTE: Refer to your Parts Manual for specific hardware used.

1. Install two (2) Cutter Heads on each lift head tube, as shown.

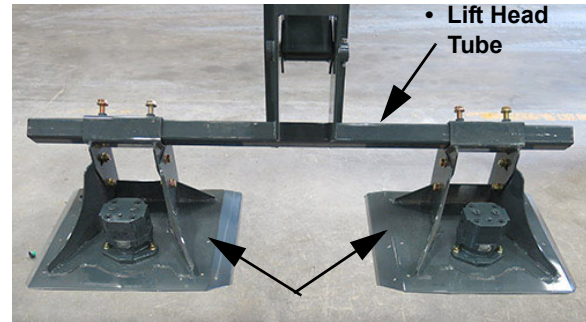

Cutter Heads
-Typical View

2. Ensure each Cutter Head measures 16" (40.6 cm) from the outside of the mount head to the outside of the cutter head mounting tube, making adjustments as necessary.

NOTE: Distance may vary depending on planting pattern.

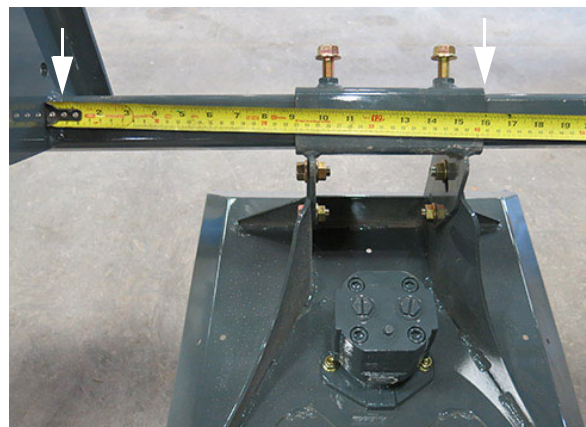

- Measure 16" (40.6 cm) from the outside of the mount head to the outside of the cutter head mounting tube

3. Ensure each Cutter Head measures 30" (76.2 cm) from center of each cutter head motor.

NOTE: Distance may vary depending on planting pattern.

NOTE: Repeat process, measuring across each lift mount.



- Measure 30" (76.2 cm) from center of each cutter head motor



- Measure 30" (76.2 cm) from center of each cutter head motor, across each lift mount

4. Using a 3/4" socket, tighten each Cutter Head Bolt (two on each Cutter Head Mounting Tube).



Cutter Head Bolts
(Located on each
Cutter Head Mounting Tube)
-Typical View

5. Install two Stalk Guides on each Cutter Head, positioned as shown.



- Install eight (8) Stalk Guide Bolts (4 each side) through bottom of each Cutter Head/Stalk Guide.
- Install eight (8) Stalk Guide Nuts (4 each side) onto the bolts and tighten with a 7/16" socket.



Stalk Guide Installation
-Typical View

6. Apply anti-seize lubricant to inside of Cutter Blade Adapter Plug.

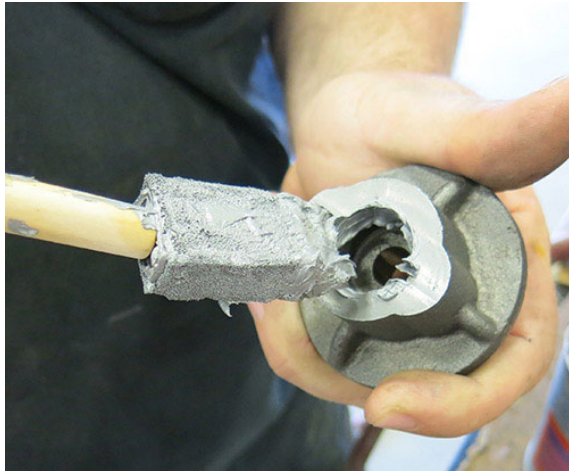

Anti-Seize Lubricant Application
-Typical View

7. Install Cutter Blade Adapter Plug onto center of blade.

NOTE: Ensure adapter plug is installed on the “edged” side of blade, as shown.



- *Install Cutter Blade Adapter Plug onto center of blade*

8. Assemble Retaining Bolt, Lock Washer, and Steel Washer together, as shown.

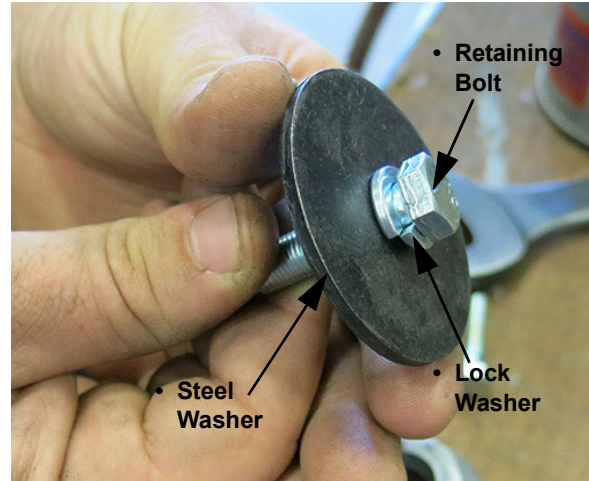

Cutter Blade Bolt/Washer Assembly
-Typical View

9. Insert Cutter Blade Bolt/Washer Assembly through bottom of blade/adapter plug.

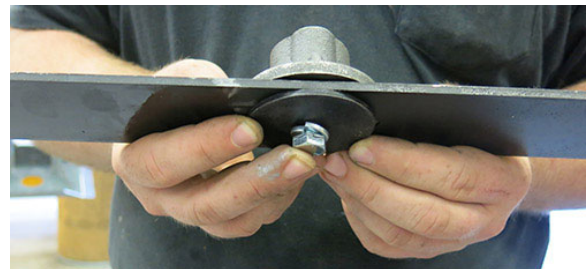

Cutter Blade Assembly
-Typical View

10. Install Cutter Blade Assembly through bottom side of Cutter Head (as shown) and tighten Retaining Bolt using a 9/16” socket.

NOTE: Inspect and tighten Retaining Bolts daily.



Cutter Blade Assembly
(Mounted on the bottom
side of Cutter Head)
-Typical View

NOTE: Repeat Steps 6-10 for each Cutter Head.

11. Install Cutter Head Extension Flap on the rear side of the center four (4) Cutter Heads.

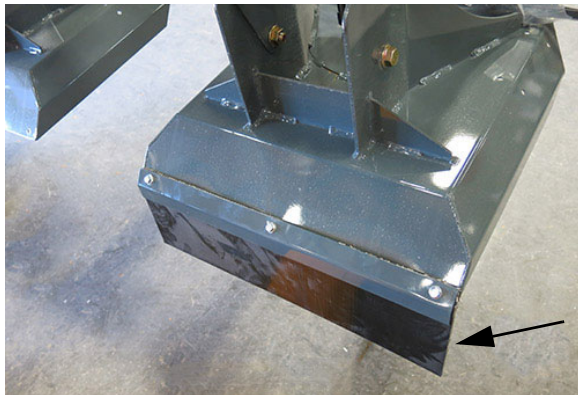

Cutter Head Extension Flap
-Typical View

12. Install hydraulic hoses.

NOTICE

Care should be taken when installing check valve on the cutter motor to ensure the flow arrow is oriented correctly.

NOTICE

Case drain hoses must be installed correctly on cutter motors to prevent motor damage. Refer to parts manual.

Blade Rotation (Left of Operator)

NOTE: Hydraulic hoses on Cutter Heads must be connected so the blades on the heads (mounted left of the operator) rotate “counter-clockwise” from above, according to the following illustrations. Refer to your Parts Manual for correct hardware, hose lengths, and hydraulic schematics.

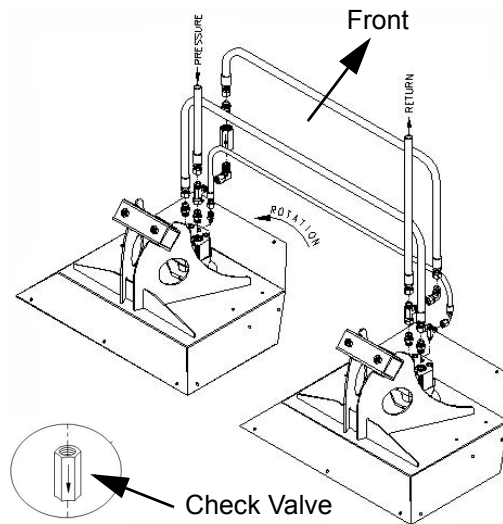

Blade Rotation - Left of Operator
(Two-Head Series)
-Typical View

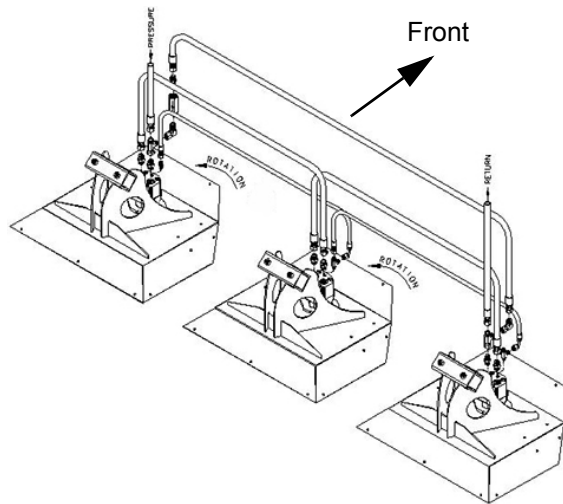

Blade Rotation - Left of Operator
(Three-Head Series)
-Typical View

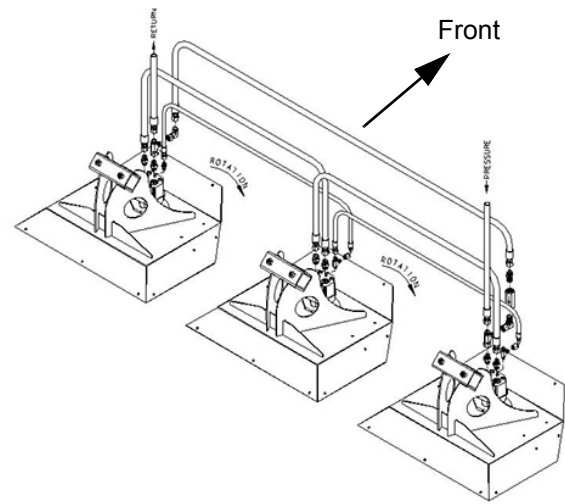

Blade Rotation - Right of Operator
(Three-Head Series)
-Typical View

Blade Rotation (Right of Operator)

NOTE: Hydraulic hoses on Cutter Heads should be connected so the blades on the heads (mounted right of the operator) rotate “clockwise” from above, according to the following illustrations.

Refer to your Parts Manual for correct hardware, hose lengths, and hydraulic schematics.

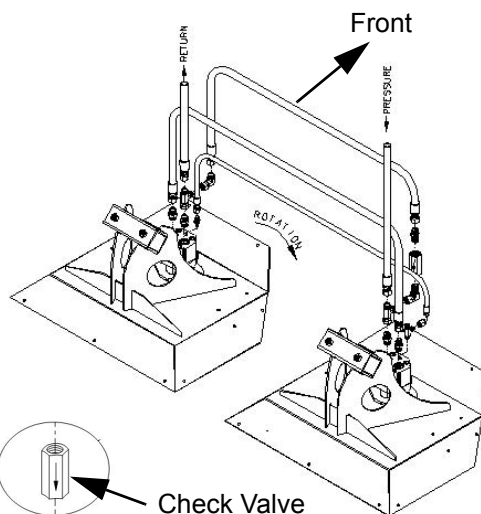

Blade Rotation - Right of Operator
(Two-Head Series)
-Typical View

LS System/Depth Command Assembly

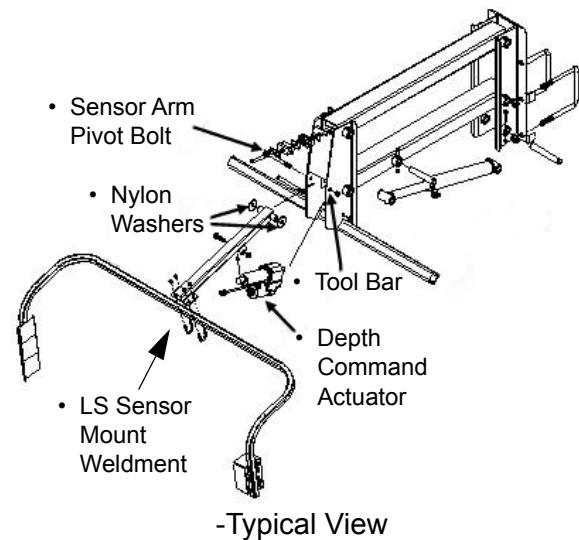

-Typical View

1. Install the LS Sensor Mount Weldment with the two Nylon Washers in the forward-most hole of the Tool Bar.
2. Install the LS Sensor Mount Weldment to the Sensor Mount (located on the support arm).
3. Install the Cable Assembly according to the wiring diagram provided in your Parts Manual.

4. Check sensor installation by turning the ignition key to the ON position. DO NOT start the engine.
5. Attach the Depth Command Actuator to the Light Sensor Mount and Tool Bar.

NOTICE

Over-tightening of the Sensor Arm Pivot Bolt may cause the actuator to stall.

Quad Puller Assembly

NOTE: Some Quad Pullers may come pre-assembled to the tool bar.



CAUTION

RISK OF INJURY FROM ROTATING TIRES. DO NOT PLACE FINGERS OR HAND NEAR MOVING QUAD PULLER TIRES, DISLODGE A WEDGED OBJECT FROM MOVING TIRES, OR PERFORM MAINTENANCE NEAR MOVING TIRES.

NOTICE

Ensure quad puller tires have equal pressure. Check tire pressure daily.

NOTE: Refer to your Parts Manual for specific hardware used.

1. Install two (2) Quad Pullers on each lift head tube, as shown.



Quad Puller
-Typical View

2. Ensure each Quad Puller measures 16" (40.6 cm) from the outside of the mount head to the outside of the quad puller mounting tube, making adjustments as necessary.

NOTE: Distance may vary depending on planting pattern.

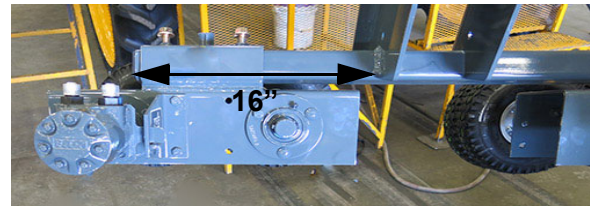

- Measure 16" (40.6 cm) from the outside of the mount head to the outside of the quad puller mounting tube

3. Using a 3/4" socket, tighten each Quad Puller Bolt (two on each Quad Puller Mounting Tube).



Quad Puller Bolts
(Located on each
Quad Puller Mounting Tube)
-Typical View

4. Install two Stalk Guides onto each Quad Puller, positioned as shown.
 - Install four (4) Stalk Guide Bolts (2 each side) through the front side of each Stalk Guide/Quad Puller.
 - Install four (4) Stalk Guide Nuts (2 each side) onto the bolts and tighten with a 7/16" socket.

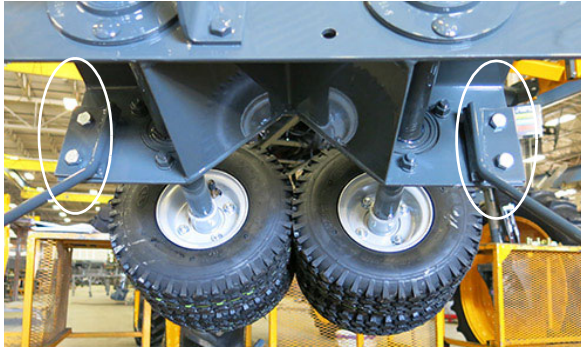

- Install four (4) Stalk Guide Bolts through the front side of each Stalk Guide/Quad Puller

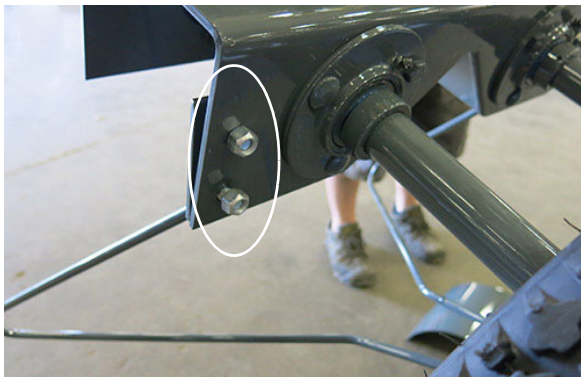

- Install four (4) Stalk Guide Nuts onto the bolts and tighten with a 7/16" wrench

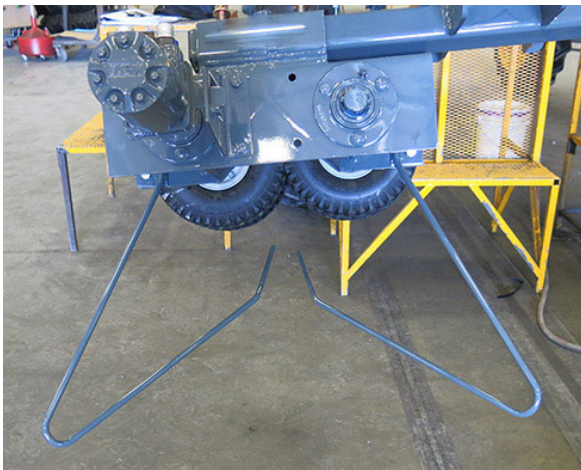

Stalk Guide Installation
-Typical View

5. Install Deflector Shield Mounting Tube onto each Quad Puller (as shown) and tighten bolts with 7/16" wrench.

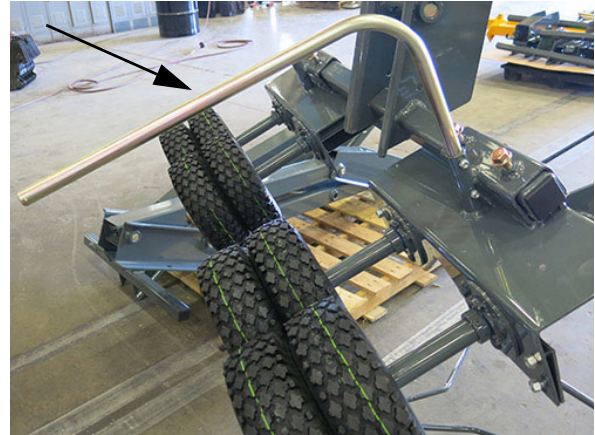

Deflector Shield Mounting Tube
-Typical View

6. Install Deflector Shield onto Deflector Shield Mounting Tube and tighten bolts with 1/2" wrench.

NOTE: Always mount Deflector Shields to direct tassels away from machine.

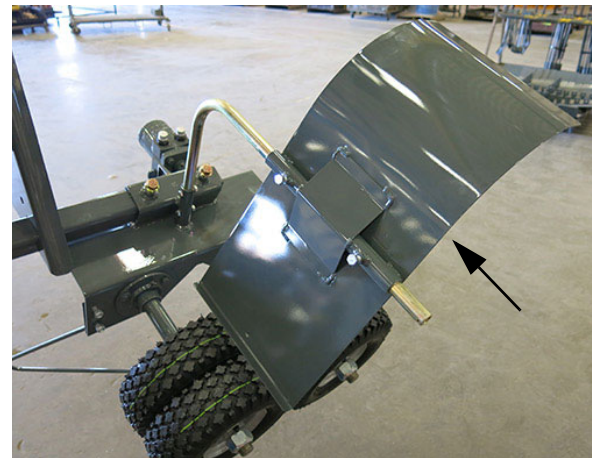

Deflector Shield
-Typical View

7. Install Cotter Pin on the end of each Deflector Shield Mounting Tube.

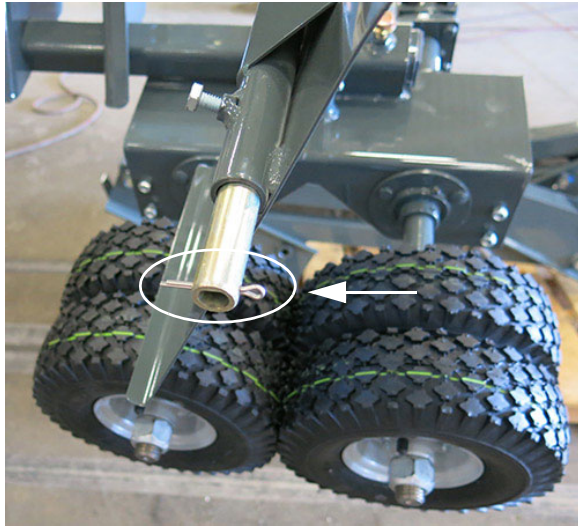

Cotter Pin
-Typical View

8. Install hydraulic hoses.

NOTE: Hydraulic hoses on Quad Puller head should be connected so tires rotate according to the following illustrations. Refer to your Parts Manual for correct hardware, hose lengths, and hydraulic schematics.

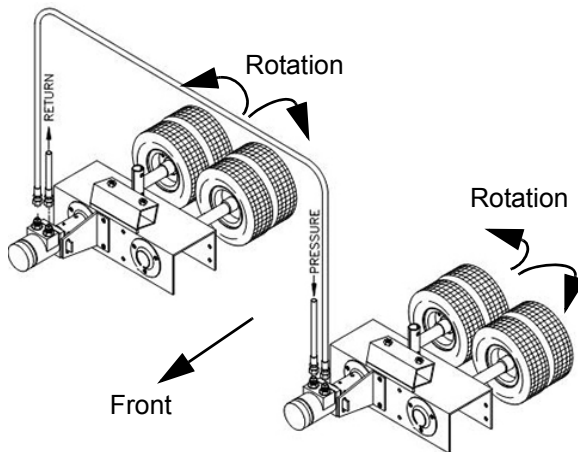

Quad Puller Hydraulic Assembly
(Two-Head Series)
-Typical View

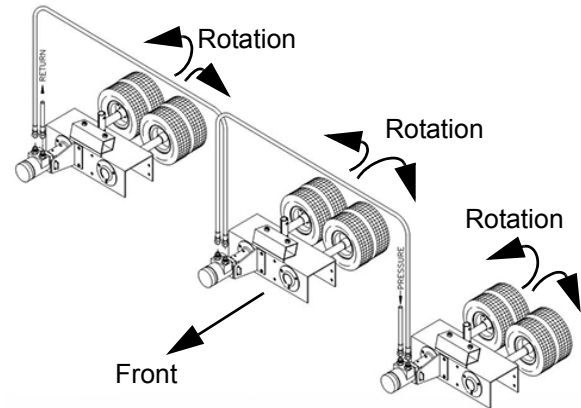

Quad Puller Hydraulic Assembly
(Three-Head Series)
-Typical View

- Adjust tire pressure to approximately 10 psi (.7 bar).

WHEEL TREAD AND ROW SPACING

Knowing the row spacing of the field that is to be detasseled, refer to the following steps to obtain proper tread.

Adjusting Tread Width

- Park machine on level ground.
- Engage the parking brake.
- Shut engine OFF.
- Loosen the Leg Mounting Bolts (located on the front and rear legs) **on one side of the machine only.**

CAUTION

Loosen leg mounting bolts only enough to allow for free movement of leg on mainframe. Do not remove bolts under any circumstances.

NOTE: Refer to “Service - Lubrication” provided in the Maintenance and Storage Section elsewhere in this manual for further information.

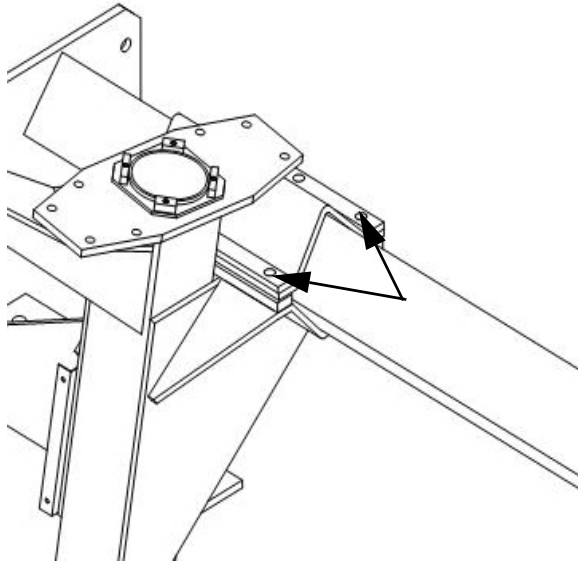

Leg Mounting Bolts
(Six on each leg)
-Typical View

5. Loosen Rear Lock Nut (located on leg brace) to allow one leg to move further than the other without binding (when adjusting tread setting).



Rear Lock Nut
(Located on leg brace)
-Typical View

6. Lubricate the slide path in which the leg mount will travel along mainframe (approximately 30”/76 cm).

NOTICE

Failure to inspect and lubricate the tread adjust bearing slide path may cause one of the legs to “hang up” while the other is still sliding during adjustment. Failure to comply may result in machine damage.

7. Place a suitable prop item (e.g. wood block) beneath the air bag mounting plate (before raising the machine) to prevent the suspension from telescoping, as shown in the following illustration.

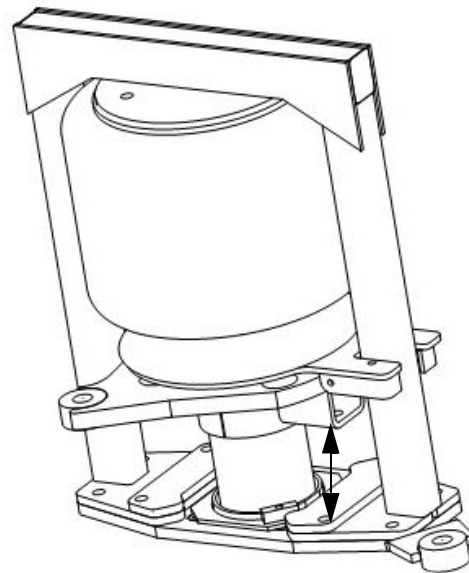

-Typical View

8. Raise the machine until the tires (on the side being adjusted) are just touching the ground.

To Adjust Tread Width Out

- Place a suitable prying tool beneath the center of tire and pry out at the same time, while simultaneously pushing out at the top of the leg, as shown in the following photo.



-Typical View

- Carefully lower the machine to the ground, which in turn, will allow the leg to slide outward.
- Repeat procedure until desired tread width is obtained.

To Adjust Tread Width In

- Raise the machine until the tires (on the side being adjusted) are just off the ground.
- Carefully lower the machine to the ground, which in turn, will allow the top of the leg to slide in on the mainframe.
- Re-tighten Leg Mounting Bolts.
- Re-tighten the Leg Brace Lock Nut.
- Repeat previous procedure to adjust and set the legs on opposite side of machine.

NOTE: When finished, all four legs should be the same distance from the mainframe.

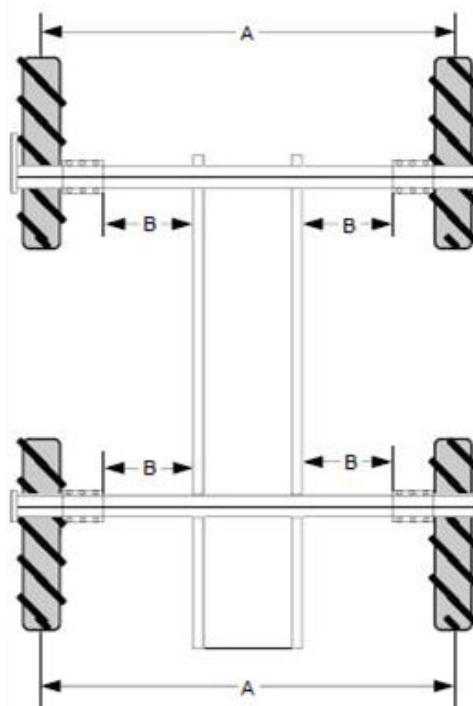

**HANDRAIL EXTENSION -
REMOVABLE**

The Handrail Extension may be removed to access the engine hoods (located on both sides of machine).

**To Remove the Handrail
Extensions**

1. Remove the two (2) Handrail Pins (located on the top and bottom of Handrail Extension).

Tread Width		
DIM A		DIM B
120" (304.8 cm)	=	25.5" (64.8 cm)
114" (289.6 cm)	=	22.5" (57.2 cm)
108" (274.3 cm)	=	19.5" (49.5 cm)
90" (228.6 cm)	=	10.5" (26.7 cm)



Handrail Pins
(Located on the top and
bottom of handrail extension)
-Typical View

2. Remove Handrail Extension and set aside.
3. Repeat steps to remove Handrail Extension on opposite side of machine.

NOTE: Reverse steps to reinstall Handrail Extensions.

TROUBLESHOOTING

Problem	Possible Cause	Suggested Remedy
Engine will not crank	<ul style="list-style-type: none"> • Dead battery • Poor battery connections • Neutral Safety Switch • Starter or starter relay • Lock-out Switch in LOCKED position 	<ul style="list-style-type: none"> • Charge or replace battery • Clean and tighten • Adjust (replace, if necessary) • Test, rebuild, or replace • Inspect switch
Engine will not start	<ul style="list-style-type: none"> • Fuel tanks empty • Clogged fuel filters • Cold weather • Low starter speed 	<ul style="list-style-type: none"> • Fill fuel tanks • Replace fuel filters • Refer to the engine manufacturer's user guide • Check starter and battery
Engine overheats	<ul style="list-style-type: none"> • Engine overload • Dirty radiator core/grille screens • Faulty radiator cap • Loose or faulty fan belt • Faulty thermostat • Low coolant level 	<ul style="list-style-type: none"> • Reduce load • Remove foreign material and clean all items • Replace cap • Tighten or replace fan belt • Replace thermostat • Refill to proper level with recommended coolant
Engine misfires: runs uneven/low power	<ul style="list-style-type: none"> • Water in fuel • Dirty air cleaner element • Poor grade of fuel • Fuel tank vent clogged • Clogged fuel filters 	<ul style="list-style-type: none"> • Drain, flush, replace filters, fill system • Replace element • Drain system, change to a better grade fuel • Open fuel tank vent (in cap) • Replace fuel filters
Engine knocks	<ul style="list-style-type: none"> • Low oil level in crankcase • Cold engine 	<ul style="list-style-type: none"> • Add oil to full mark • Allow proper warm-up period, refer to the engine manufacturer's user guide for cold weather starting
Machine will not move in either direction	<ul style="list-style-type: none"> • Engine speed too low • Oil level in hydraulic reservoir low • Control linkage • Clogged filter • Faulty hydrostatic pump • Air leak in suction line • Low charge pressure 	<ul style="list-style-type: none"> • Set engine at operating RPM before moving the machine • Fill hydraulic reservoir to proper level with approved oil • Repair or replace • Replace filter • Replace pump • Inspect and tighten all fittings on suction line • Contact your local John Deere dealer for assistance

**SECTION 9 –
MISCELLANEOUS**



Machine will move in only one direction	<ul style="list-style-type: none"> • Faulty Flow Divider Valve 	<ul style="list-style-type: none"> • Replace valve
Hydrostatic System responding slowly	<ul style="list-style-type: none"> • Engine speed too low • Oil in hydraulic reservoir low • Cold oil • Plugged filter • Partially restricted suction line • Internal damage 	<ul style="list-style-type: none"> • Set engine at operating RPM before moving the machine • Fill hydraulic reservoir to proper level with approved oil • Allow adequate warm-up period • Replace filter • Inspect for collapsed suction hose • Replace hydrostatic pump or motor
Noisy Hydrostatic System	<ul style="list-style-type: none"> • Cold oil • Low engine speed • Oil level in hydraulic reservoir low • Air in system • Internal damage to pump 	<ul style="list-style-type: none"> • Allow adequate warm-up period • Increase engine RPM • Fill hydraulic reservoir to proper level with approved oil • Inspect and tighten all fittings on suction line • Replace pump
External oil leaks	<ul style="list-style-type: none"> • Loose or faulty fittings • Damaged o-ring • Faulty hose 	<ul style="list-style-type: none"> • Tighten or replace • Replace o-ring • Replace hose
Entire hydraulic system fails to function	<ul style="list-style-type: none"> • Oil level in hydraulic reservoir low • Oil not reaching pump • Faulty hydraulic pump 	<ul style="list-style-type: none"> • Fill hydraulic reservoir to proper level with approved oil • Prime the pump by removing suction hose from reservoir. Hold removed end higher than the pump. Hand-feed two quarts of approved oil through the suction hose by bumping engine with starter (ensuring NOT to start the engine). Reinstall hose. Tighten all fittings. • Replace hydraulic pump
Noisy hydraulic pump	<ul style="list-style-type: none"> • Collapsed suction hose (caused by cold oil) • Oil level in hydraulic reservoir low • Air leak in suction line 	<ul style="list-style-type: none"> • Allow for adequate warm-up period • Fill hydraulic reservoir to proper level with approved oil • Inspect and tighten all fittings on the suction hose

Lifting mechanism will not lift	<ul style="list-style-type: none"> • Bad cylinder • Blown relief valve • Relief valve set too low • Lift arms seized • Faulty electro-hydraulic valve 	<ul style="list-style-type: none"> • Check cylinder - remove, rebuild, or replace • Replace valve • Reset to 2000 PSI (137.9 bar) • Loosen mounting bolts, lubricate grease fittings (if equipped) • Refer to the Tasselrol user guide
Cutter head blades, quad pullers, rollers, or ties will not turn	<ul style="list-style-type: none"> • Oil level in hydraulic reservoir too low • Oil not reaching pump • Faulty hydraulic pump • Faulty hydraulic motor(s) 	<ul style="list-style-type: none"> • Fill hydraulic reservoir to proper level with approved oil • Remove suction hose from pump and check for proper flow. Reinstall hose and all suction fittings. • Replace hydraulic pump • Replace motor(s)
Hydraulic motor leaking	<ul style="list-style-type: none"> • Seal failure • Restricted case drain hose 	<ul style="list-style-type: none"> • Replace seal, turn heads on with low engine RPM • Inspect or replace hose
No units will lift	<ul style="list-style-type: none"> • Oil in hydraulic reservoir low • Faulty valve • Relief valve in electro-hydraulic valve set too low 	<ul style="list-style-type: none"> • Fill hydraulic reservoir to proper level with approved oil • Repair or replace valve • Contact your local John Deere dealer for assistance
No units will lower	<ul style="list-style-type: none"> • All lift arm pivots too tight 	<ul style="list-style-type: none"> • Lubricate and loosen pivot points
Only one unit will not lower	<ul style="list-style-type: none"> • Faulty valve • Lift arm pivot too tight 	<ul style="list-style-type: none"> • Replace valve • Lubricate and loosen pivot point
All units lift slowly	<ul style="list-style-type: none"> • Hydraulic oil not at operating temperature • Faulty valve • Lift arm pivots too tight • Plugged high pressure filter • Relief valve in electro-hydraulic valve system set too low 	<ul style="list-style-type: none"> • Allow time for oil to warm up • Replace valve • Lubricate and loosen pivot points • Remove, clean, or replace • Contact your local John Deere dealer for assistance
Only one unit lifts slowly	<ul style="list-style-type: none"> • Faulty valve • Lift arm pivot points too tight 	<ul style="list-style-type: none"> • Replace valve • Lubricate/loosen pivot point
Only one unit will not hold position	<ul style="list-style-type: none"> • Oil leak between valve and cylinder • Faulty valve • Faulty lower poppet on lift valve 	<ul style="list-style-type: none"> • Repair leak or replace hose • Replace valve • Remove, clean, or replace
No units will hold position	<ul style="list-style-type: none"> • Problem is not hydraulic 	<ul style="list-style-type: none"> • Refer to “Tasselrol/LS System 12” provided elsewhere in this manual

**SECTION 9 –
MISCELLANEOUS**



Only one unit lowers slowly	<ul style="list-style-type: none"> • Faulty valve • Faulty lower poppet on lift valve 	<ul style="list-style-type: none"> • Replace valve • Remove, clean, or replace
All units lower slowly	<ul style="list-style-type: none"> • Hydraulic oil not at operating temperature 	<ul style="list-style-type: none"> • Allow time for oil to warm up
In MANUAL mode, more than one unit lifts or lowers from one up/down switch	<ul style="list-style-type: none"> • Faulty valve 	<ul style="list-style-type: none"> • Replace valve
In AUTO mode, more than one unit raises from photo sensor	<ul style="list-style-type: none"> • Faulty valve 	<ul style="list-style-type: none"> • Replace valve
In AUTO mode, wrong unit raises from photo sensor	<ul style="list-style-type: none"> • Cylinder hoses are connected to the wrong cylinder 	<ul style="list-style-type: none"> • Attach correct hoses to proper cylinder
No units will lift	<ul style="list-style-type: none"> • Faulty Auto/Manual Switch • Blown Fuse • Faulty #1 valve, coil, or loose coil mounting nut • Loose wire connections • Faulty wire connections • Faulty main wire assembly 	<ul style="list-style-type: none"> • Replace control box • Find short in wire, repair, and replace fuse • Tighten nut or replace coil • Find loose connection, tighten • Replace or repair • Replace or repair
Only one unit will not lift	<ul style="list-style-type: none"> • In MANUAL mode, faulty Up/Down Switch • Light photo sensor assembly • Faulty valve, coil, or loose coil mounting nut • Loose wire connections • Lights of photo sensor not lined up with reflector • Faulty row wire assembly • Faulty sensor connector wire assembly 	<ul style="list-style-type: none"> • Replace control box • Replace photo sensor • Tighten nut or replace coil • Find loose connections, tighten • Line up sensor with reflector • Replace or repair • Replace or repair
No units will lower	<ul style="list-style-type: none"> • Faulty Auto/Manual Switch • Blown fuse • Loose wire connections • In AUTO mode, LS valve assembly unplugged 	<ul style="list-style-type: none"> • Replace switch • Find short in wire, repair, and replace fuse • Find loose connection, tighten • Plug in wire assembly

Only one unit will not lower	<ul style="list-style-type: none"> • Faulty Up/Down Switch • In AUTO mode, faulty light sensor assembly • Loose wire connections • Faulty valve coil or loose coil mounting unit • Faulty sensor connector wire assembly • In AUTO mode, light sensor not lined up with reflector • Faulty row LS wire assembly 	<ul style="list-style-type: none"> • Replace control box • Replace sensor • Find loose connections, tighten • Tighten nut or replace coil • Replace or repair • Line up sensor with reflector • Replace or repair
No units will hold position	<ul style="list-style-type: none"> • In AUTO mode, no crop moving under assemblies 	<ul style="list-style-type: none"> • Drive forward or select MANUAL mode
In AUTO mode, wrong unit raises from sensor assembly	<ul style="list-style-type: none"> • Row LS wire assembly plugged into wrong sensor connector 	<ul style="list-style-type: none"> • Plug correct wire assembly into proper row sensor connector assembly
Entire electrical system is dead	<ul style="list-style-type: none"> • Dead battery • Poor battery connection • Low charging rate • No charging rate • Lockout Switch in LOCKED position 	<ul style="list-style-type: none"> • Charge or replace battery • Clean and tighten battery connections • Tighten alternator belt • Replace alternator • Inspect switch
All gauges on instrument panel not working	<ul style="list-style-type: none"> • Blown fuse • Poor ground 	<ul style="list-style-type: none"> • Replace fuse • Clean and tighten ground
Tachometer/MPH-km/h indicator not working	<ul style="list-style-type: none"> • Blown fuse • Loose connections at sensor/ alternator • Faulty sensor 	<ul style="list-style-type: none"> • Replace fuse • Tighten or replace connectors • Replace sensor
Light system does not function	<ul style="list-style-type: none"> • Blown fuse • Burned out bulb • Separation or short in wire • Blown fuse • Faulty switch • Ignition switch is OFF 	<ul style="list-style-type: none"> • Clean and tighten ground • Replace bulb • Check continuity and replace wire • Replace fuse • Replace switch • Turn ignition switch to the ON position

Machine Valve Type

NOTICE

Ensure the machine valve type is correctly selected to match the machine in which the Tasselrol® control box is installed on.

- **o** = Any machine with the original valve (Model Year 2007 or prior).
- **p** = 204/204SP machines with the new proportionate valve (Model Year 2008 or later).
- **c** = STS Combo Sprayer/Detasseler with the proportionate valve (Model Year 2007 or later).
- **x** = 204XP and DTS 8C (Combination Sprayer/Detasseler) with 12 valves (Model Year 2010).

To obtain further information on the status of the Tasselrol/LS System before operation:

- Turn the ignition key to the ON position (do not start the engine).
- Press the On/Off Switch (located on the Tasselrol Control Panel) in the UP (On) position.
- Press the Auto/Manual Switch (located on the Tasselrol Control Panel) in the DOWN (Manual) position.
- Ensure there is nothing physically blocking any upper or lower sensor's path to its reflector.

The display will show the status of the upper and lower photo sensor on each lift assembly. If the display shows a box ("□") in all upper and lower areas, the unit is ready for operation. If the display shows a corn stalk ("☿") in one or more areas, refer to the following troubleshooting information.

NOTE: Left-Center sensors are used as examples.

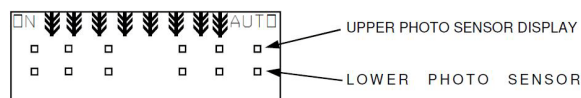

Tasselrol Display

Manual Mode

Auto Mode

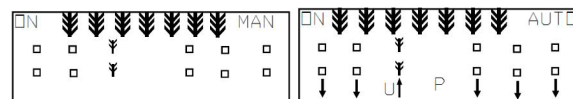

Unit rises automatically

Photo Sensor Light Status	Possible Cause
Lights at both photo sensors	<ul style="list-style-type: none"> • Photo sensors not in line with reflector. Contact your local John Deere dealer for assistance.
No lights at either photo sensor	<ul style="list-style-type: none"> • Faulty connector cable (refer to your Parts Manual) • Faulty wire in connector cable (refer to your Parts Manual)

Tasselrol Display

Manual Mode

Auto Mode

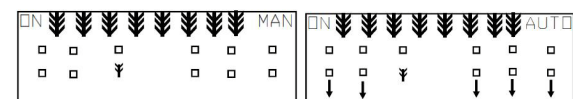

Unit does NOT rise automatically

Photo Sensor Light Status	Possible Cause
Lights at lower photo sensor	<ul style="list-style-type: none"> Faulty wire in connector cable (refer to your Parts Manual). Photo sensor not in line with reflector. Contact your local John Deere dealer for assistance. Faulty wire in sensor assembly (refer to your Parts Manual).
No lights at lower photo sensor	<ul style="list-style-type: none"> Faulty wire in connector cable (refer to your Parts Manual).

Tasseltrol Display

Manual Mode

Auto Mode

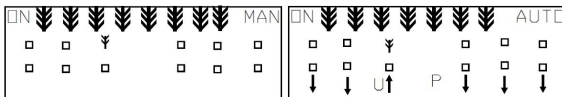

Unit rises automatically

Photo Sensor Light Status	Possible Cause
Lights at upper photo sensor	<ul style="list-style-type: none"> Faulty wire in sensor assembly (refer to your Parts Manual).
No lights at upper photo sensor	<ul style="list-style-type: none"> Faulty wire in connector cable (refer to your Parts Manual).



A Word From Hagie Manufacturing	
Company	1-1
About This Manual	1-1
Attachments - Assembly and	
Installation	9-6
Batteries	6-1
Battery Disconnect Switch	6-2
Detasseling System - Operation	7-7
Detasseling System Components	7-1
Emergency Exit	2-7
Emergency Stop	2-5
Engine - Starting	4-1
Engine Monitor	4-2
Fire Extinguisher	2-7
Fuse and Relay Ratings	6-6
Fuses and Relays	6-3
Handrail Extension - Removable	9-16
Hydraulic System	5-1
Hydrostatic Drive	4-5
Identification	1-2
Intended Use	2-1
Operator Presence Switch (OPS)	2-6
Operator's Station	3-2
Product Warranty	1-2
Rotating Beacon	2-5
Safety Decals	2-8
Safety Messages Used In This	
Manual	1-2
Safety Precautions	2-1
Seat - Operator	3-1
Seat - Operator (Air Suspended)	3-1
Seat Belt	2-4
Service - Air Springs	8-19
Service - Belts	8-15
Service - Bolt Torque	8-16
Service - Filters	8-8
Service - Fluids	8-1
Service - Lubrication	8-13
Service - Miscellaneous	8-19
Service - Toe-In	8-17
Service and Assistance	1-2
Service Intervals	8-21
Specifications	1-5
Storage	8-23
Tasselrol Flowchart	7-18
Tasselrol®/LS System 12™	7-8
Transporting	9-1
Troubleshooting	9-18
Wheel Tread and Row Spacing	9-14

