

# CALIFORNIA

## Proposition 65

WARNING: Diesel engine exhaust and some of its constituents are known to the State of California to cause cancer and birth defects or other reproductive harm.

WARNING: Battery posts, terminals, and related accessories contain lead and lead compounds, chemicals known to the State of California to cause cancer and birth defects or other reproductive harm.



**ANY PICTURES CONTAINED WITHIN THIS OPERATOR'S MANUAL THAT DEPICT SITUATIONS WITH SHIELDS, GUARDS, RAILS, OR LIDS REMOVED ARE FOR DEMONSTRATION PURPOSES ONLY. HAGIE MANUFACTURING COMPANY STRONGLY URGES THE OPERATOR TO KEEP ALL SHIELDS AND SAFETY DEVICES IN PLACE AT ALL TIMES.**

# **HAGIE** 204SP



## **OPERATOR'S MANUAL FOR HAGIE MODEL 204SP DETASSELER**

### **HAGIE MANUFACTURING COMPANY**

721 CENTRAL AVE WEST  
BOX 273  
CLARION, IOWA 50525-0273

(515) 532-2861

COVERS MACHINE SERIAL NUMBERS: U1011121001 through U1011121300

10-12 493489

© 2011 Hagie Manufacturing Company. Clarion, Iowa USA

# ABBREVIATIONS

A/C .....	AIR CONDITIONING	MT.....	MOUNT
ADJ .....	ADJUST	MTH.....	MONTH
ADPTR .....	ADAPTER	MTR.....	MOTOR
ALT.....	ALTERNATOR	NO .....	NUMBER
AMP .....	AMPERE	OD .....	OUTSIDE DIAMETER
APPROX .....	APPROXIMATELY	PLT .....	PLATE
ASSY.....	ASSEMBLY	PRESS.....	PRESSURE
AUX.....	AUXILIARY	PRKNG.....	PARKING
BRKT.....	BRACKET	PSI.....	POUNDS PER SQUARE INCH
BTRY.....	BATTERY	QT .....	QUART
C.....	CELSIUS	RAD .....	RADIATOR
CCA.....	COLD CRANKING AMPS	REC .....	RECOMMENDED
CTRL.....	CONTROL	REQ.....	REQUIRED
CYL .....	CYLINDER	RPM.....	REVOLUTIONS PER MINUTE
DIAG.....	DIAGRAM	SAE.....	SOCIETY of AUTOMOTIVE ENGINEERS
DIM.....	DIMENSION	SEC .....	SECOND
DISPL.....	DISPLACEMENT	SERV .....	SERVICE
EA .....	EACH	SLCTR.....	SELECTOR
ELECT.....	ELECTRIC	SMV .....	SLOW MOVING VEHICLE
F .....	FAHRENHEIT	SOLE .....	SOLENOID
FIG .....	FIGURE	SPEC.....	SPECIFICATION
FLO .....	FLOW	STRG.....	STEERING
FRT .....	FRONT	SQ.....	SQUARE
FT.....	FOOT OR FEET	TACH.....	TACHOMETER
GA .....	GAUGE	TEMP.....	TEMPERATURE
GAL .....	GALLON	TERM.....	TERMINAL
HAL .....	HALOGEN	TRD .....	TREAD
HR.....	HOOR	TT .....	TUBE-TYPE
HYD.....	HYDRAULIC	TU .....	TUBELESS
HYDRO .....	HYDROSTATIC	VAR .....	VARIABLE
ID.....	INSIDE DIAMETER	V .....	VOLT
IN.....	INCH	VFC.....	VARIABLE FLOW CONTROL
INFO.....	INFORMATION	VLV.....	VALVE
Km/H .....	KILOMETERS PER HOUR	W .....	WEIGHT
LB.....	POUND	W/ .....	WITH
LS.....	LIGHT SENSOR	W/O.....	WITHOUT
MAINT.....	MAINTENANCE	WHL.....	WHEEL
MIN.....	MINUTE	WK.....	WEEK
M/F .....	MAINFRAME	WLD.....	WELDMENT
MPH .....	MILES PER HOUR		

# TO THE OWNER

---

## CAUTION

READ OPERATOR'S MANUAL. BE ALERT. LEARN TO OPERATE THIS MACHINE SAFELY. OBSERVE ALL SAFETY PRACTICES. MACHINES CAN BE HAZARDOUS IN THE HANDS OF AN UNFAMILIAR, UNTRAINED, OR COMPLACENT OPERATOR. SHUT OFF ENGINE BEFORE SERVICING. WHEN MECHANISM BECOMES CLOGGED, SHUT OFF ENGINE BEFORE CLEANING. DON'T RISK INJURY OR DEATH.

650852

## A WORD FROM HAGIE MANUFACTURING COMPANY

Congratulations on your selection of a Hagie Model 204 SP DETASSELER. We recommend that you study this Operator's Manual and become acquainted with the adjustments and operating procedures before attempting to operate your new detasseler. As with any piece of equipment, certain operating procedures, service, and maintenance are required to keep it in top running condition.

We have attempted herein to cover all of the adjustments required to fit varying conditions. However, there may be times when special care must be considered.

Hagie Manufacturing Company reserves the right to make changes in the design and material of any subsequent detasseler without obligation to existing units.

We thank you for choosing a Hagie detasseler and assure you of our continued interest in its satisfactory operation for you. If we might be of assistance to you, please call us.

We are proud to have you as a customer.

# CAUTION

READ OPERATOR'S MANUAL. BE ALERT. LEARN TO OPERATE THIS MACHINE SAFELY. OBSERVE ALL SAFETY PRACTICES. MACHINES CAN BE HAZARDOUS IN THE HANDS OF AN UNFAMILIAR, UNTRAINED, OR COMPLACENT OPERATOR. SHUT OFF ENGINE BEFORE SERVICING. WHEN MECHANISM BECOMES CLOGGED, SHUT OFF ENGINE BEFORE CLEANING. DON'T RISK INJURY OR DEATH.

650852

## TO THE OPERATOR

The following pages and illustrations will help you operate and service your new detasseler. It is the responsibility of the user to read the Operator's Manual and comply with the safe correct operating procedures and lubricate and maintain the product according to the maintenance schedule.

The user is responsible for inspecting the machine and having parts repaired or replaced when continued use of the product causes damage

or excessive wear to other parts.

Keep this manual in a convenient place for easy reference when problems arise. This manual is considered a permanent fixture with this machine. In the event of resale, this manual should accompany the detasseler. If you do not understand any part of the manual or require additional information or service, contact the Hagie Customer Support Department:

Hagie Manufacturing Company  
Box 273, Clarion, IA 50525  
(515) 532-2861

The following symbols, found throughout this manual, alert you to potentially dangerous conditions to the operator, service personnel, or the equipment.



*This symbol indicates an immanently hazardous situation which, if not avoided, will result in death or serious injury.*



*This symbol indicates a potentially hazardous situation which, if not avoided, could result in death or injury.*



*This symbol indicates a potentially hazardous situation which, if not avoided, may result in minor or moderate injury. It may also be used to alert against unsafe practices.*

# TABLE OF CONTENTS

I.	SAFETY/ DECALS.....	4-12
II.	DETASSELER IDENTIFICATION .....	21-22
III.	SPECIFICATIONS .....	23-29
IV.	PREPARING TO OPERATE.....	30-41
V.	OPERATING INFORMATION.....	42-80
VI.	TRANSPORTING .....	81-85
VII.	SERVICE AND MAINTENANCE.....	86-114
VIII.	STORAGE .....	115-116
IX.	TROUBLE SHOOTING.....	117-133
X.	LIMITED WARRANTY.....	134
XI.	INDEX.....	135

# I. SAFETY/DECALS

---

## SAFETY PRECAUTIONS

Most accidents occur as the result of failure to follow simple and fundamental safety rules. For this reason, most accidents can be prevented by recognizing the real cause and doing something about it before the accident occurs.

Many conditions cannot be completely safeguarded against without interfering with efficient operation and/or reasonable accessibility.

Therefore, you must study this Operator's Manual and learn how to use the detasseler controls for safe operation. Likewise, do not let anyone operate without instruction.

Do not make modifications such as weldments, add-ons, adaptations, or changes from the original design of detasseler. Such changes and/or modifications may become safety hazards

### DRIVING

- Before moving the detasseler, make sure no persons or obstructions are in the path of travel.
- Do not permit passengers on the detasseler when it is moving; they may fall off or obstruct the operator's view.
- Never drive near ditches, embankments, holes, mounds, or other obstacles.
- Never drive on hills too steep for safe operation.
- Always drive at a reasonable field speed.
- Reduce the detasseler's speed before turning.
- Come to a complete stop before reversing direction.
- Pull over to the side of road before stopping.
- Use the flashing/hazard warning lights when traveling on public roads, day or night, unless prohibited by local law.
- Make sure the SMV emblem is in place and visible from the rear when traveling on public roads.

# I. SAFETY/DECALS

---

## OPERATING

### TREAD WIDTH

- Select the widest tread setting to fit between the crop rows.
- Never manually adjust the tread width on the detasseler until the wheels have been properly blocked. Loosen the leg clamp bolts only enough for the leg to slide on the frame.

### OUTRIGGERS

- Make sure the outriggers are locked down either when folded in or folded out.

### GENERAL OPERATION SAFETY

- Do not adjust the factory engine RPM settings.
- Start the engine from the operator's seat only. Do not by-pass the safety-start switch.
- Handle starting fluid with care. Keep it away from open flame. Store it with the cap on in a cool place.
- Never run the detasseler engine in a closed building. Proper exhaust ventilation is required.
- If equipped with light sensing depth units, do not look directly into light beam. It emits a very low intensity microwave signal which may cause possible eye damage.
- Keep all shields in place.
- Keep clear of all moving parts and keep others away when operating.
- Do not wear loose fitting clothing that may be blown or drawn into moving parts.
- Never allow walking personnel in the same field as a detasseler.
- Keep a fire extinguisher close at all times.



# I. SAFETY/DECALS

---

## REPAIR/MAINTENANCE

### HYDRAULICS

- Use caution when working with hydraulic fluid under pressure. Escaping hydraulic fluid can have sufficient force to penetrate your skin, causing serious injury. This fluid may also be hot enough to burn.
- Always lower load or relieve hydraulic pressure before repairing a hydraulic oil leak.
- Avoid torching, welding, and soldering near pressurized hydraulic lines.

### FUELING

- Always turn the engine off and allow it to cool before refueling.
- Do not smoke while refueling.
- Do not fill fuel tank completely. Fuel may expand and run over.

### GENERAL REPAIR/MAINTENANCE

- Turn off engine before checking, adjusting, repairing, lubricating, or cleaning any part of the detasseler.
- When servicing the radiator, let engine cool before removing pressurized cap.
- Disconnect the battery ground cable before servicing electrical system or welding on machine.
- When charging battery, connect positive cable to positive terminal and negative cable to negative terminal. Failure to do so may result in an explosion and cause injury. Likewise, avoid battery acid contact and incurring injuries.
- Never pressurize suspension air bags over 100 psi.

# I. SAFETY/DECALS

## WARNING DECALS

Decals warning you of avoidable danger are located on various parts of the detasseler. They are there for your personal safety and protection. DO NOT remove them. They will fracture upon attempted removal and therefore must be replaced.

Following are locations of important safety decals. Replace them if they are torn or missing. All

warning decals and other instructional Hagie decals or machine striping may be purchased through the Hagie Customer Support Department. To replace decals, be sure that the installation area is clean and dry; decide on exact position before you remove the backing paper.

## DECAL LOCATION



650303

Front of operator station (2) or cab (1).



650175

Front of cab.



# I. SAFETY/DECALS

## DECALS CONTINUED



650389

Steering column of cab (1) or operator station (2).



Hagie Part Number: 650258

2 on each cutter head housing.

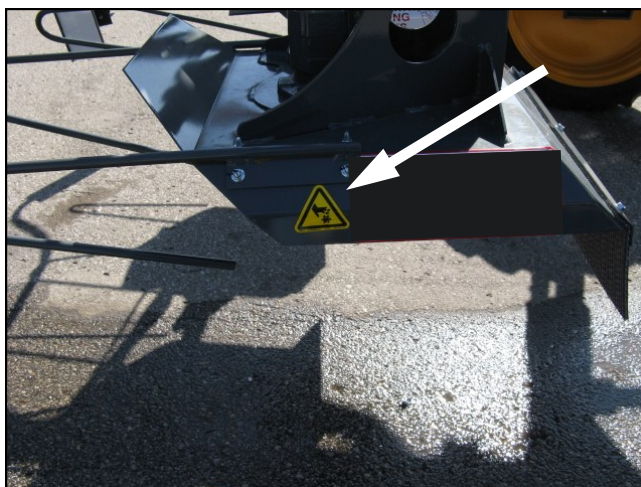

Hagie Part Number: 650259

Quad puller head.

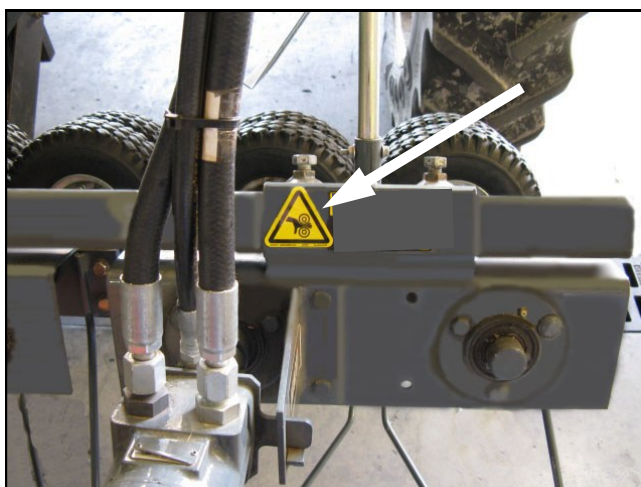

# I. SAFETY/DECALS

## DECALS CONTINUED



650388

Steering column of cab (1) or operator station (2).

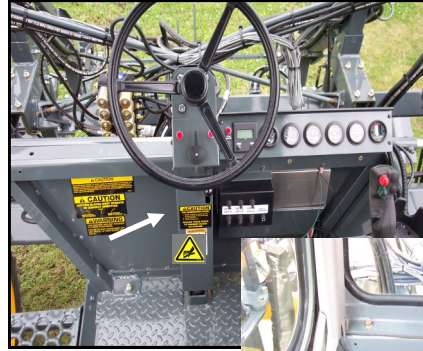

2



1



650847

Front of operator station (1) or outside cab, under back window (2).



2



1



Part of console decal 650378

Console, right of toggle switch.



1

# I. SAFETY/DECALS

## DECALS CONTINUED



Hagie Part Number: 650260

Right of either ladder on the leg brace.



650849 (1)



650954 (2)

Top of each fuel tank.

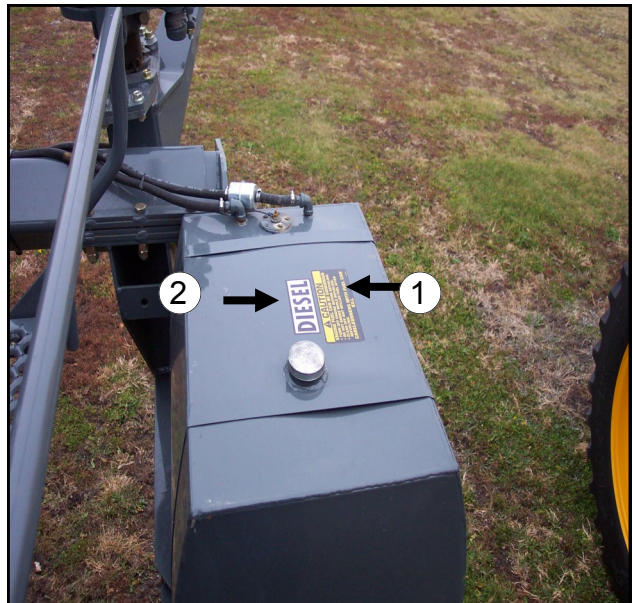

Hagie Part Number: 650256

Front of mullion to left of radiator cap.



# I. SAFETY/DECALS

## DECALS CONTINUED



Right and left rear mainframe. 650851

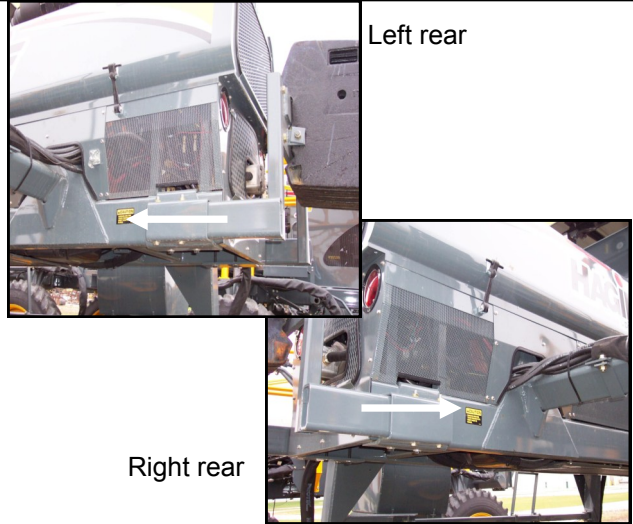

Front of operator station (1) or front of cab (2).

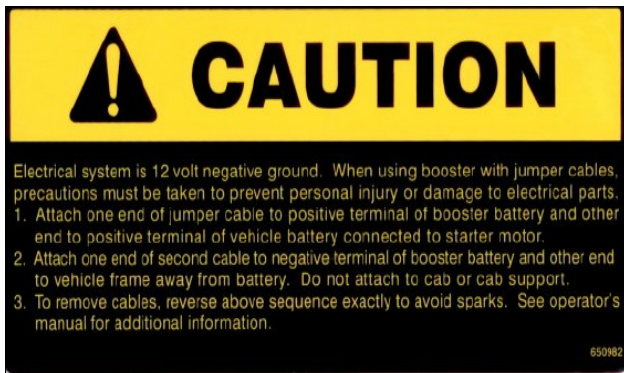
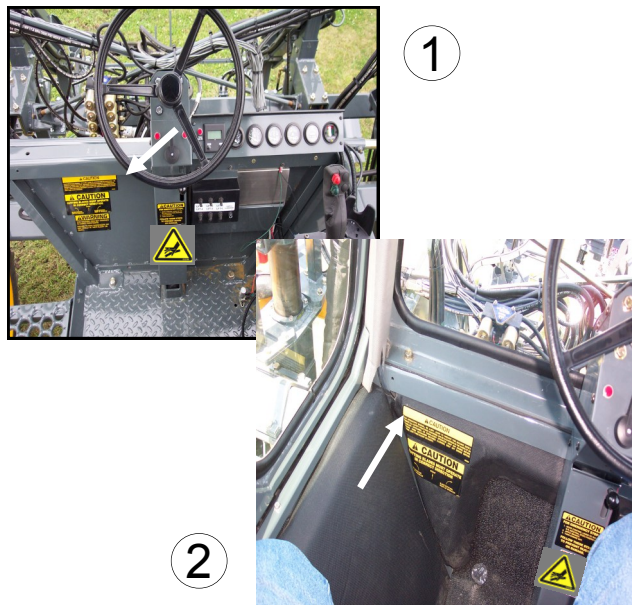

On the hydraulic reservoir, left of the battery 650982



# I. SAFETY/DECALS

## DECALS CONTINUED

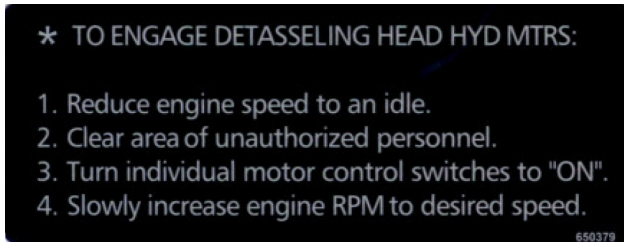

650379

Top of console lid and inside console lid.

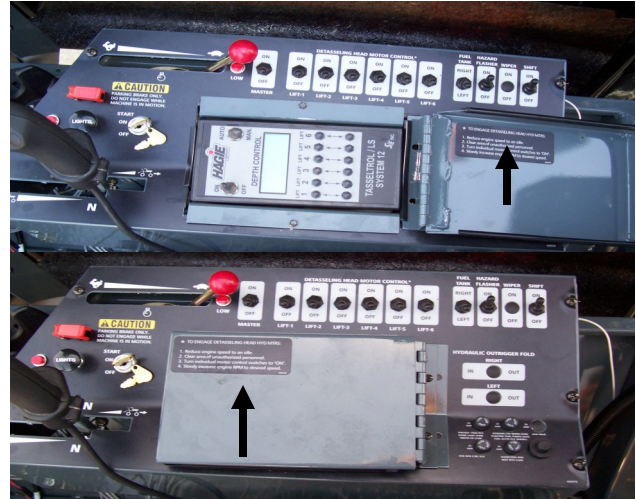

The following decals are not available from the Hagie 204 Parts Manual, but should be replaced if they are faded, damaged, or missing. They are located on the right hand vertical post of the roll over protection equipment . They are placed there by our vendor.

The top decal warns of impairment to the structure's (the roll over protection) protective capabilities due to roll over, structural damage, or alteration. If any of these conditions should occur, the structure must be replaced.

The bottom decal warns of the use of the seat-belt.

Hagie Manufacturing urges you to obey all warnings found in this manual and on the decals placed on the machine and its components. We ask that you not take it upon yourself to alter the equipment or do maintenance beyond your capabilities.

At Hagie Manufacturing we strive to put safety first, we ask that you do the same.



# I. SAFETY/DECALS



These decals are located on the roll over protection post above the roll over protection decal (see above).

The decals represent:

- A. Wear hearing protection while operating this machine.
- B. Wear eye protection when operating this machine.
- C. Read the operator's manual.
- D. Refer to the service and maintenance instructions.



Hagie Part Number: 650251



Hagie Part Number: 650250



Hagie Part Number: 650249



Hagie Part Number: 650248



# I. SAFETY/DECALS

This decal is located in the center rear of the machine next to the battery disconnect switch.

The decal identifies the electrical circuit can be broken preventing the machine from starting when the key is turned to the OFF position.

Do not use this device as a safety when working on the electrical system— disconnect the negative battery cable before servicing.



Hagie Part Number: 650252



Hagie Part Number: 650253

# I. SAFETY/DECALS



This decal is located on the top of the engine compartment near the exhaust tube.

The decal is to warn the operator that the exhaust tube may be hot enough to burn. Avoid touching the exhaust tube while the machine is running. Allow the engine plenty of time to cool down before performing any service or maintenance procedures.



Hagie Part Number: 650255

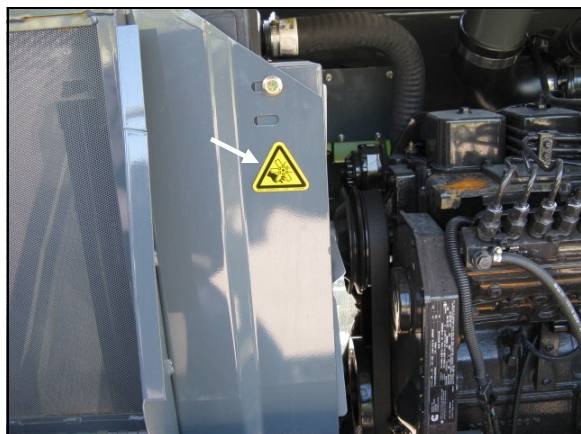

This decal is located in the engine compartment on the left hand side of the fan guard.

The decal warns the operator that putting their hand beyond the protective guard may result in serious injury from a moving fan blade.



Hagie Part Number: 650257

# I. SAFETY/DECALS



Hagie Part Number: 650260

This decal is located on the right hand side of the ladder (both ladders) near the top.

The decal indicates that there is a trip hazard at the top of the ladder. Use caution when entering the operator's station.

## REMOVABLE HANDRAIL

Handrail extensions must be moved to open engine hoods on both sides of machine.

1. Remove handrail
2. Open hood
3. Close hood and return handrail to original position.



# I. SAFETY/DECALS



This decal is located on both sides the canopy of the operator's station.

The decal warns the operator of the risk of bumping their head while entering the operator's station.



Hagie Part Number: 650254



This decal is located on the engine compartment shield, near the radiator cap.

The decal warns the operator of the risk of expulsion of material during servicing. Do not stand in the path of the material to avoid injury.



Hagie Part Number: 650256

# I. SAFETY/DECALS

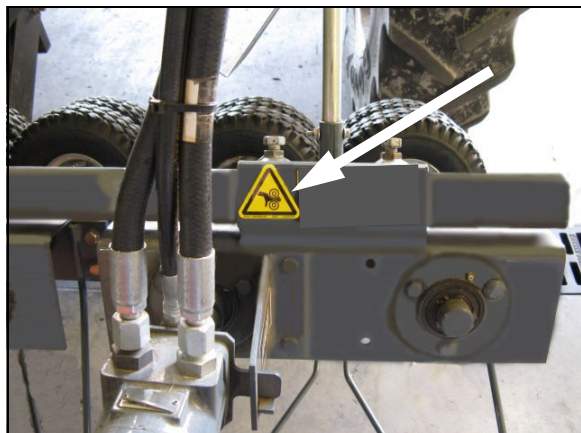

This decal is located on the mounting tube of each puller head.

The decal warns the operator that there is risk of injury from the rotating tires. Never attempt to perform any service or maintenance on the pullers while they are rotating! Never attempt to dislodge a wedged object from the pullers with your hand!



Hagie Part Number: 650259

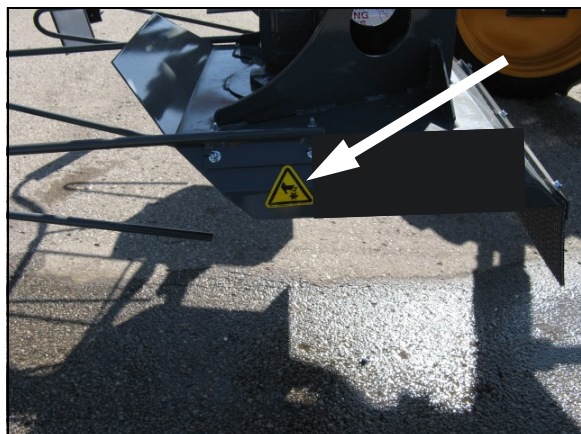

This decal is located on both sides of the cutter head assemblies.

The decal warns the operator that putting your hand past the protective guard may result in serious injury by the rotating blade. Never attempt to perform any maintenance on a moving cutting blade or try to stop the blade!



Hagie Part Number: 650258

# I. SAFETY/DECALS

## Lift Points

This decal is located on both sides of the main-frame at each bend of the belly shield which is attached underneath.

The decal specifies the 4 lifting points to use simultaneously to lift the machine safely.

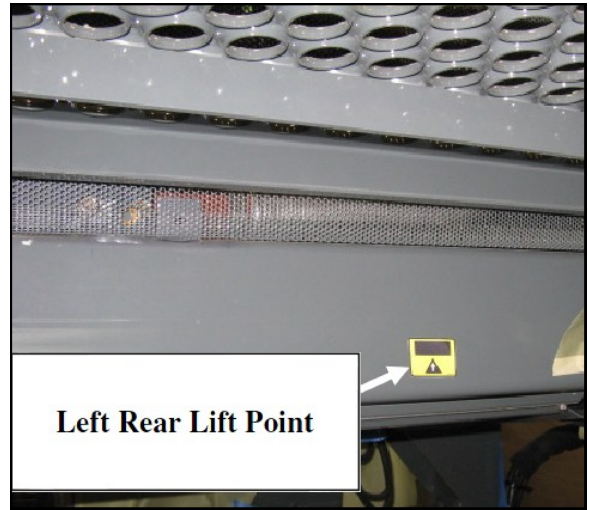

## Rotating Beacon

There is a rotating beacon mounted on the left hand side of the operator's station. This light is used for increased visibility to others.

The light will illuminate when the flashing hazard lights are activated.



## E-Stop

The emergency stop is attached to the operator's station frame in front of the side console.

The emergency stop switch provides a quick and positive method for stopping the engine in an emergency situation. When the button is depressed, it locks in position and removes the ignition signal to shutdown the engine. To reset the switch, turn the button in the direction of the arrows on the face of the button.

Do not use this button for non-emergency stopping or as a parking brake.



# 204 MODIFICATIONS

## Operator Presence Switch

The operator presence switch (OPS) is located in the seat. The switch protects the operator from exposure to moving parts or hazards in regards to the detasseler cutting blades or quad pullers by introducing an electrical interlock that ensures that when the operator is out of the seat for 3 seconds or more, the operation of these functions is stopped.

To reengage the cutting blades or quad pullers, the operator must be seated. Turn the master control switch to the off position, then to the on position. All operating functions will resume.



## Tow Point

**Towing of a detasseler is not recommended, but if it should become necessary, follow the procedure in the Operator's Manual for disengaging the wheel hubs and motors.**

Attach (4) 10 foot long (3.048m) chains, one to each of the legs at the specified point (see picture). Make sure to attach them in such a way that they will not slip off.

Attach the loose end of the front two chains to the towing vehicle and loose end of the rear two chains to the braking vehicle. Be sure to read the operator's manual for the towing vehicles to determine the safest hooking point for the vehicle.

Do not tow the machine for long distances. Do not use towing as a way of transporting the machine between fields. Towing should only be used as a last resort in any situation as damage can occur to the machine.

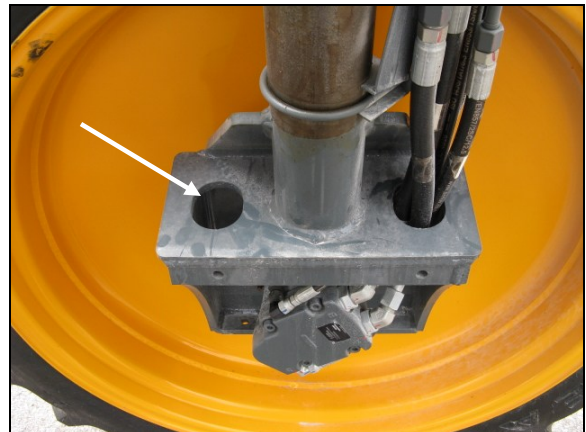

## II. IDENTIFICATION NUMBERS

### DETASSELER IDENTIFICATION

Each Hagie detasseler is identified by means of a frame serial number. This serial number denotes the model, year in which it was built, and the number of the detasseler. For further identification, the engine has a serial number, the hydrostatic pump has a serial number, the wheel motors have identification tags, and the planetary

hubs have identification plates that describe the type of mount and gear ratio. To ensure prompt, efficient service when ordering parts or requesting service repairs from Hagie Manufacturing Company, record the serial and identification numbers in the space provided below.

#### NOTE:

Reference to left-hand and right-hand used throughout this manual refers to the position when seated in the operator's seat facing forward.



#### Detasseler

---

NOTE: Detasseler serial number stamped in the frame on right rear corner.

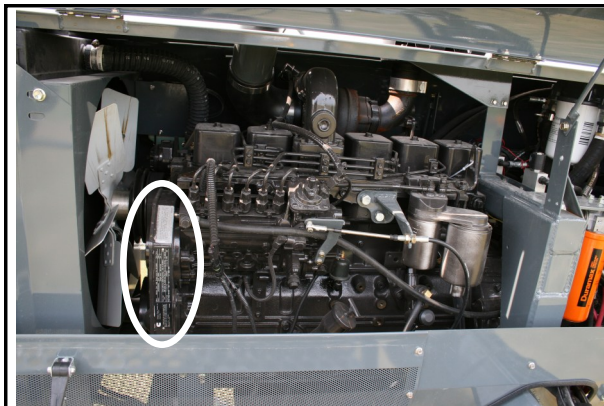

#### Engine

---

NOTE: Diesel engine serial number located on the side of the front left gear housing.



## II. IDENTIFICATION NUMBERS



### Planetary Hubs w/Brakes

Left: \_\_\_\_\_

Right: \_\_\_\_\_

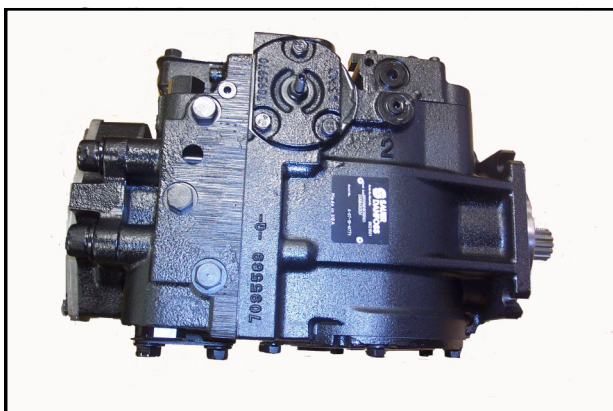

### Hydrostatic Pump

Left: \_\_\_\_\_

Right: \_\_\_\_\_



### Front and Left Rear Wheel Motors

Front Left: \_\_\_\_\_

Front Right: \_\_\_\_\_

Rear Left: \_\_\_\_\_

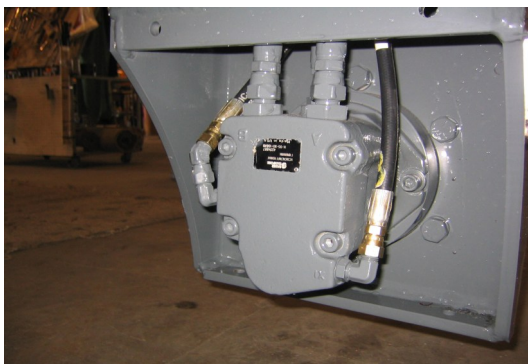

### Right Rear Wheel Motor w/ sensor

Right: \_\_\_\_\_

Refer to parts manual.

# III. SPECIFICATIONS

## DETASSELER DIMENSIONS

- |   |       |                                |      |
|---|-------|--------------------------------|------|
| A. Overall tractor height (w/cab or canopy) ..... | 144"  | F. Diesel exhaust height ..... | 140" |
| B. Lift arm range .....                           | 66"   | • Beacon                       |      |
| C. Axle height.....                               | 26.2" | -Fully extended .....          | 152" |
| D. Wheel base.....                                | 120"  | -Folded down .....             | 144" |
| E. Detasseler length (w/o attachments).....       | 206"  |                                |      |

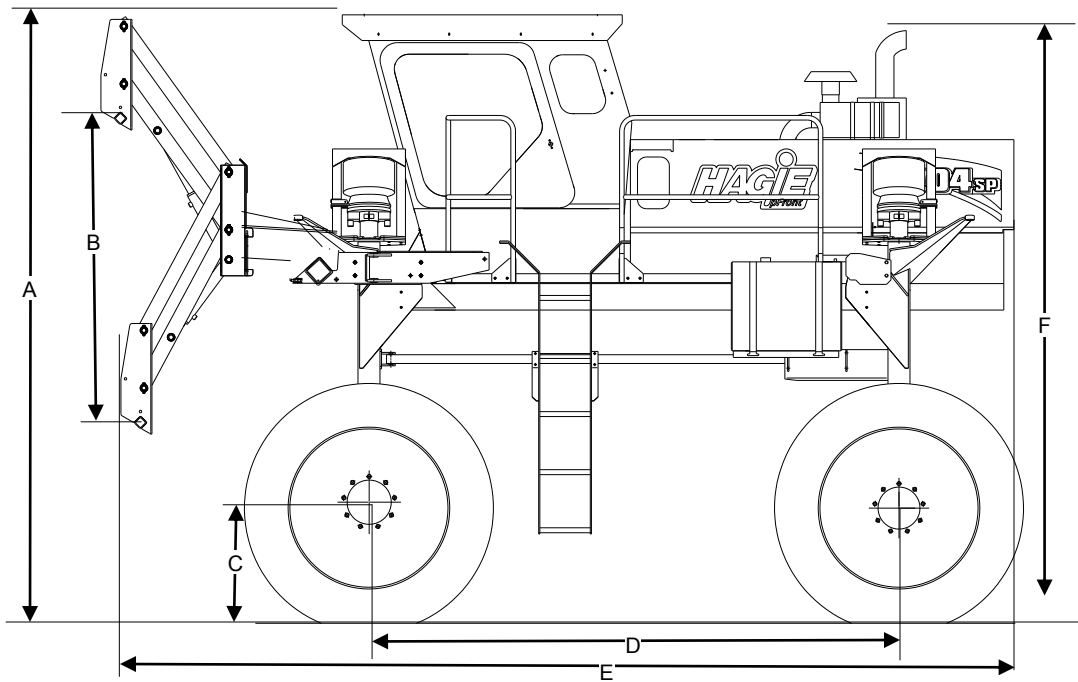

- |  |                          |
|--|--------------------------|
| G. Center clearance .....                          | 78"                      |
| H. Frame clearance .....                           | 83"                      |
| I. Lower leg clearance (front).....                | 24"                      |
| J. Tire center to inside of lower leg (front)..... | 12.5"                    |
| K. Tread width*.....                               | Adjustable<br>78" - 120" |

\*NOTE: Measure tread width at 1/2 tire height.

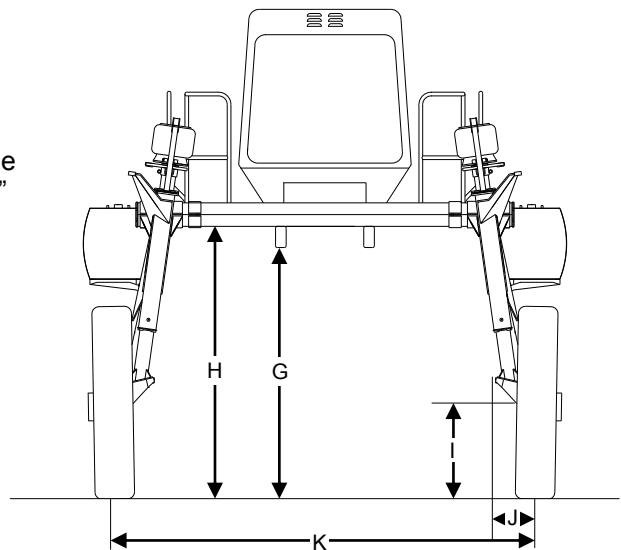

## GENERAL DETASSELER INFORMATION

- |                                    |   |
|------------------------------------|---|
| ♦Frame type .....                  | Rigid with 4-wheel, independent, air-suspension |
| ♦Approximate shipping weight ..... | 10,200 lbs. depending on options                |
| ♦Shipping width .....              | 143"  |

### III. SPECIFICATIONS

---

#### ENGINE

Manufacturer .....	Cummins
Model.....	QSB4.5 Turbocharged
Type .....	In line, liquid cooled
Number of cylinders .....	4
Displacement .....	4.5 liter
Horsepower.....	168, intermittent
Type of fuel .....	Number 1 or number 2 diesel
Fuel system.....	Filtered, direct-injected
Air cleaner .....	Dry-type, single element
Slow idle.....	800 RPM
Fast idle.....	2500 RPM

# III. SPECIFICATIONS

---

## POWER TRAIN

### Drive

Hydrostatic pump .....	Sauer/Danfoss 90 series	
Range .....	100cc variable displacement	
Drive train .....	All time four wheel drive	
Two-Speed .....	Low (0-12 mph), High (0-15)	
Hydrostatic wheel motor	- front and left rear .....	Sauer/Danfoss KC 38
	- right rear .....	Sauer/Danfoss KC 38 w/sensor
Final drives		
Type .....	Planetary Gear Reduction Hubs	
- front (11.2-38 tire) .....	Torque Hub <sup>®</sup> 7HPA w/brake Drive ratio - 24:1	
- rear .....	Torque Hub <sup>®</sup> 7HPA w/brake Drive ratio - 19:1	
Lubrication .....	Oil bath	

### Brakes

Type .....	Multiple disc Spring applied Hydraulically released
------------	---

### Steering System

Type .....	Hydraulic, priority on demand
Control .....	Full-time power
Steering cylinders .....	Double action
Turning radius .....	18' with 120" tread

## AUXILIARY HYDRAULIC SYSTEM

Type .....	Open
Pump type .....	Tandem gear
Pressure setting .....	2000 PSI

# III. SPECIFICATIONS

---

## ELECTRICAL SYSTEM

### General Electrical System

Battery .....	Single 12V, negative ground
Alternator .....	130 AMP, voltage regulated
Starter .....	12V with solenoid

### Circuit Breakers/Fuses

A/C relay (cab only) .....	30 AMP
A/C breaker (cab only) .....	30 AMP
Main Breaker .....	100 AMP
Motor control block .....	20 AMP
Tasselrol <sup>®</sup> box, seat motor (cab only) .....	20 AMP
Outrigger hydraulic fold (optional) .....	20 AMP
Depth command switch panel .....	10 AMP
Aux .....	20 AMP
ACC .....	10 AMP
Display Panel .....	5 AMP
Engine Diagnostic Plug .....	10 AMP
Beacon .....	10 AMP
Horn .....	10 AMP
Headlight .....	15 AMP
Ignition .....	5 AMP
Autosteer .....	20 AMP

### Lights (cab or canopy)

Front of cab .....	4 halogen field lights
Rear of cab .....	2 halogen work lights

# III. SPECIFICATIONS

---

## OPERATOR STATION

### Canopy (standard)

General operator station .....Tilt steering  
Flashing/hazard warning lights  
Turn signals  
Side mirrors

Seat .....Adjustment for:  
Fore-aft  
Height  
Ride firmness

### Cab (optional)

General cab .....Same as operator station, also:  
Windshield wiper  
Side mirrors  
Dome light  
Tinted glass

Temperature control .....Full-range

A/C charge type .....R-134a

Fresh air filtration .....Paper and charcoal filter

Seat .....Air ride with adjustment for:  
Fore-aft  
Backrest  
Height  
Ride firmness  
Armrest tilt

Stereo .....AM/FM/Weather Band  
with dual speakers

### Instruments

Dial gauges .....Fuel  
Digital gauge .....Speedometer (MPH-Km/H)  
Tachometer (RPM)  
Oil Pressure  
Coolant temperature  
Engine hours  
Fuel rate  
Systems Voltage  
Engine air filter monitor .....Filter Minder®

# III. SPECIFICATIONS

---

## TIRES/RIMS

### Rims (front and rear)

Standard.....38" X 10"

### Tires (front and rear)

Standard.....11.2-38 (Bias TU)

Air pressure .....26 PSI

Tire width .....11.3"

Load capacity (at 25 mph).....2540 lbs.

Overall diameter .....57.4"

Static load radius (suggested—will vary with load) .....27.3"

Rolling circumference .....170.8"

## CAPACITIES

Fuel tanks (2) .....40 gallons each

Cooling system (w/o cab heater) .....5.1 gallon

Hydraulic reservoir .....20 gallons

Engine oil capacity: (total system) .....15.9 quarts

-pan ONLY .....13.7 quarts

Torque Hub® .....16 oz. (approx.)

# III. SPECIFICATIONS

---

## DETASSELING EQUIPMENT OPTIONS

Front mounted with or without LS System

### Quad Puller

Number of rows available.....	4, 6, 8, 10, 12, or 18
Drive .....	Hydraulic
Tire size.....	4.10/3.50 2 ply
Operating speed.....	Up to 400 RPM
Pulling height.....	Minimum range – 32” to 97” Maximum range – 40” to 105”
Weight per head assembly .....	86 lbs.

### Cutter

Number of rows available.....	4, 6, 8, 10, 12, or 18
Drive .....	Hydraulic
Blade size.....	18”
Operating speed.....	Up to 3100 RPM
Cutting height .....	Minimum range – 29” to 94” Maximum range – 13” to 102”
Weight per head assembly .....	62 lbs.



# IV. PREPARING TO OPERATE

## WHEEL TREAD AND ROW SPACING

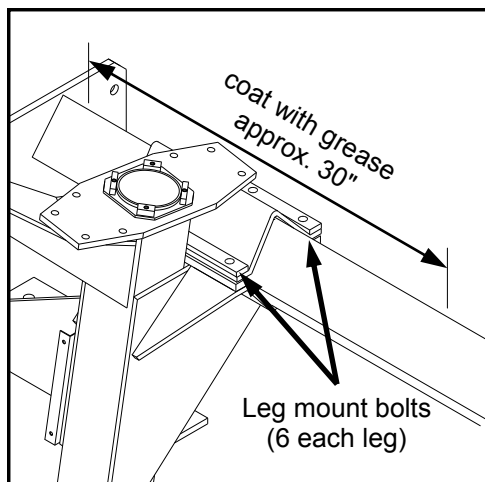

FIG 4.1



FIG 4.2

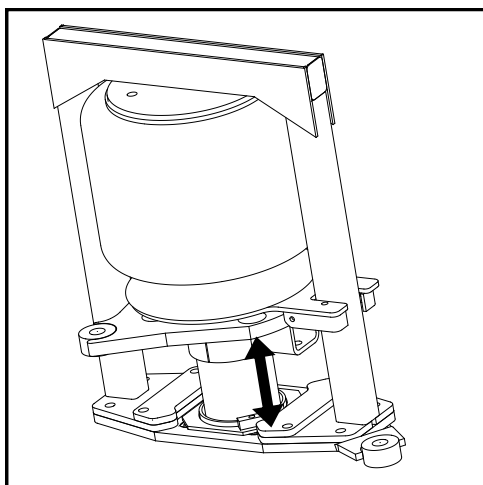

FIG 4.3

Knowing the row spacing of the field one intends to detassel, follow the steps below to properly obtain the desired tread

1. To adjust the tread width in or out, park the detasseler on level ground and shut off the engine.
2. Loosen the leg mounting bolts on both the front and rear legs on one side of the detasseler only (fig. 4.1).

### CAUTION

Loosen leg mounting bolts only enough to allow for free movement of leg on mainframe. DO NOT remove bolts under any condition.

3. Loosen the rear lock nut on the leg brace (fig. 4.2). This will allow one leg to move further than the other without binding while adjusting the tread setting.
4. Lubricate the slide path the leg mount will travel along mainframe (fig. 4.1).
5. Place a suitable block under the air bag mounting plate before raising the sprayer (fig. 4.3). This will prevent the suspension from telescoping.
6. Raise the detasseler until the tires on the side being adjusted are just touching the ground.

## IV. PREPARING TO OPERATE



FIG 4.4

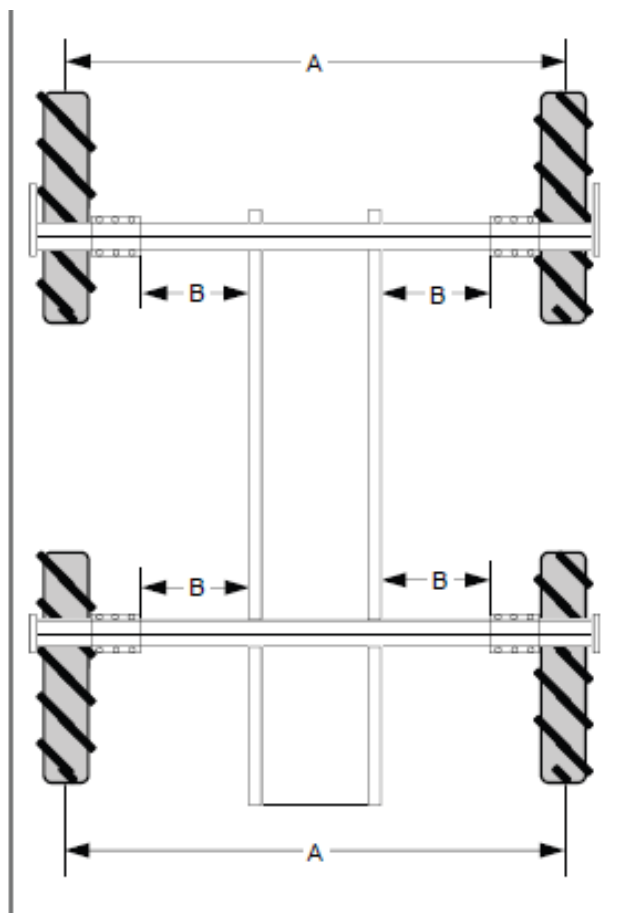

FIG 4.5

7. To adjust the tread out, place a suitable prying tool under the center of the tire and pry out at the same time that you push out at the top of the leg (fig. 4.4). Carefully lower the detasseler to the ground which, in turn will allow the leg to slide outward. Repeat the procedure until the desired tread is obtained.
8. To adjust the tread in, raise the detasseler until the tires on the side being adjusted are just off the ground. Carefully lower the detasseler which, in turn will allow the top of the leg to slide in on the mainframe.
9. Retighten leg mounting bolts following the torque specs and sequence on page 95.
10. Retighten the leg brace lock nut.
11. Repeat the above procedures to adjust and set the opposite side legs. When finished, all four legs should be the same distance from the mainframe.

Tread Width (Standard)		
DIM A (FIG 4.7)		DIM B (FIG 4.7)
120"	=	25.5"
114"	=	22.5"
108"	=	19.5"

Tread Width (Narrow Tread Option)		
DIM A (FIG 4.7)		DIM B (FIG 4.7)
90"	=	10.5"
84"	=	7.5"
78"	=	4.5"

## IV. PREPARING TO OPERATE

### TOE-IN

To correctly gauge toe-in, use a tape measure placed at one-half tire height on the front center seam of the front tire compared to the same measurement of the rear of the front tire (subtract the front measurement from the rear measurement—it must be a positive number). Correct toe-in should fall somewhere between one half and three quarters of an inch.

Toe-in is pre-set at the factory and should not have to be adjusted unless the steering cylinders are removed.

Difficulty steering one way versus the other may also indicate incorrect toe-in and may require adjustment. For further assistance regarding toe-in measurement and adjustment, contact the Hagie Customer Support Department.

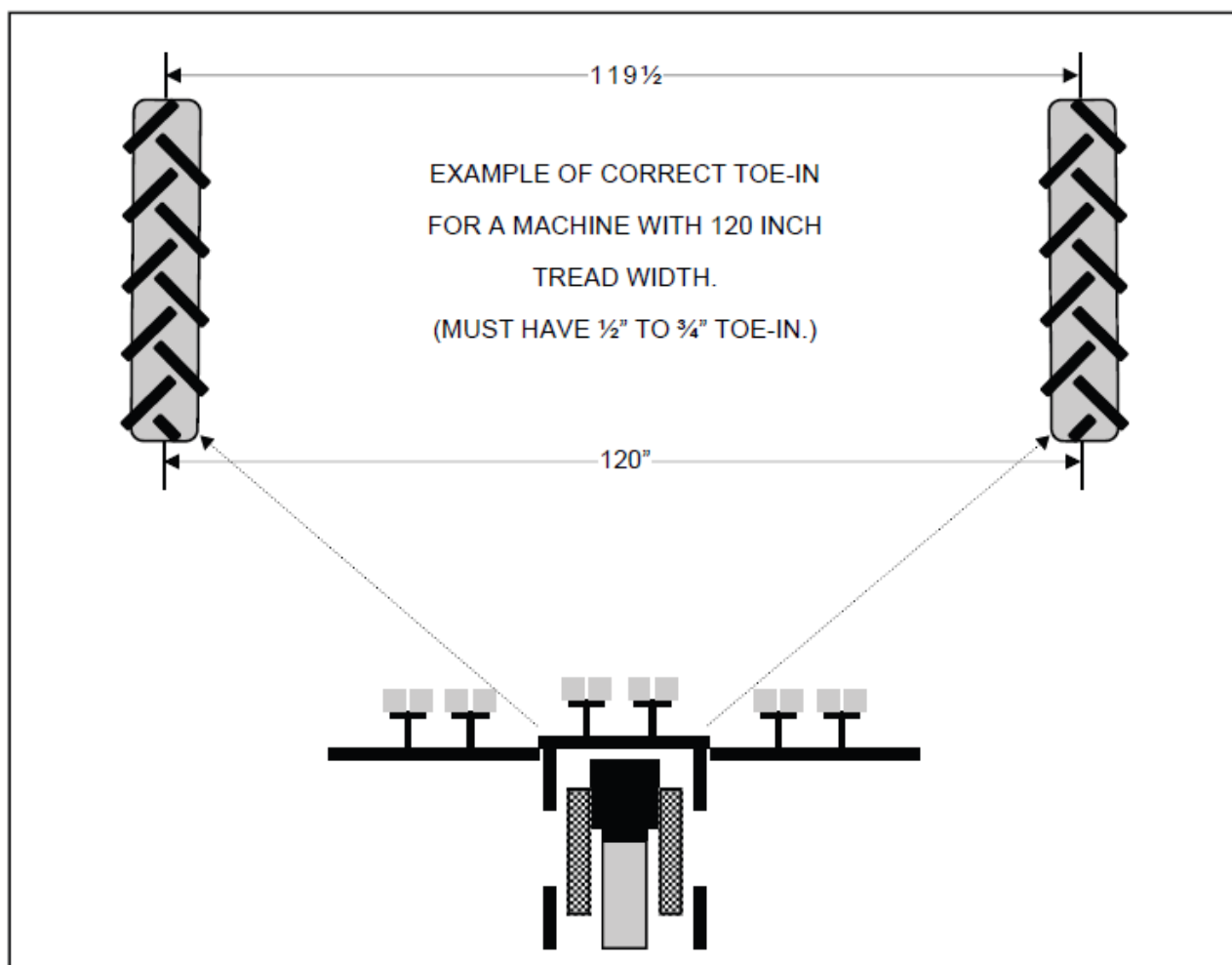

# IV. PREPARING TO OPERATE

## ATTACHING OPTIONAL COMPONENTS

In shipment, some of the components may have been sent loose (fig. 4.7) and need to be installed before operating. In order to ensure proper installation of the optional attachments, refer to your Hagie 204SP Parts Manual to the correct op-

tion for outlining the installation, hydraulic schematic, and wiring diagram. Read and comply with the following instructions. Always make sure you have proper equipment and help when installing the attachments.



FIG 4.7



### CAUTION

Firmly set the parking brake (fig. 4.8) and shut off engine before attaching components. For more information regarding parking brake operation see page 40.



FIG 4.8

# IV. PREPARING TO OPERATE

## OUTRIGGER ASSEMBLY

1. Attach the center tool bar (fig. 4.9, item 1) to front frame cross member with supplied hardware. Refer to the Hagie 204SP Parts Manual for correct hardware.

**NOTE:**

The guide pin that is welded to outrigger mount should be located toward the bottom (fig. 4.9, item 2).

2. Attach left and right outrigger (fig. 4.9, item 3) with supplied hardware. Refer to the Hagie 204SP Parts Manual.
3. Attach outrigger support rods if required (fig 4.9, item 4).

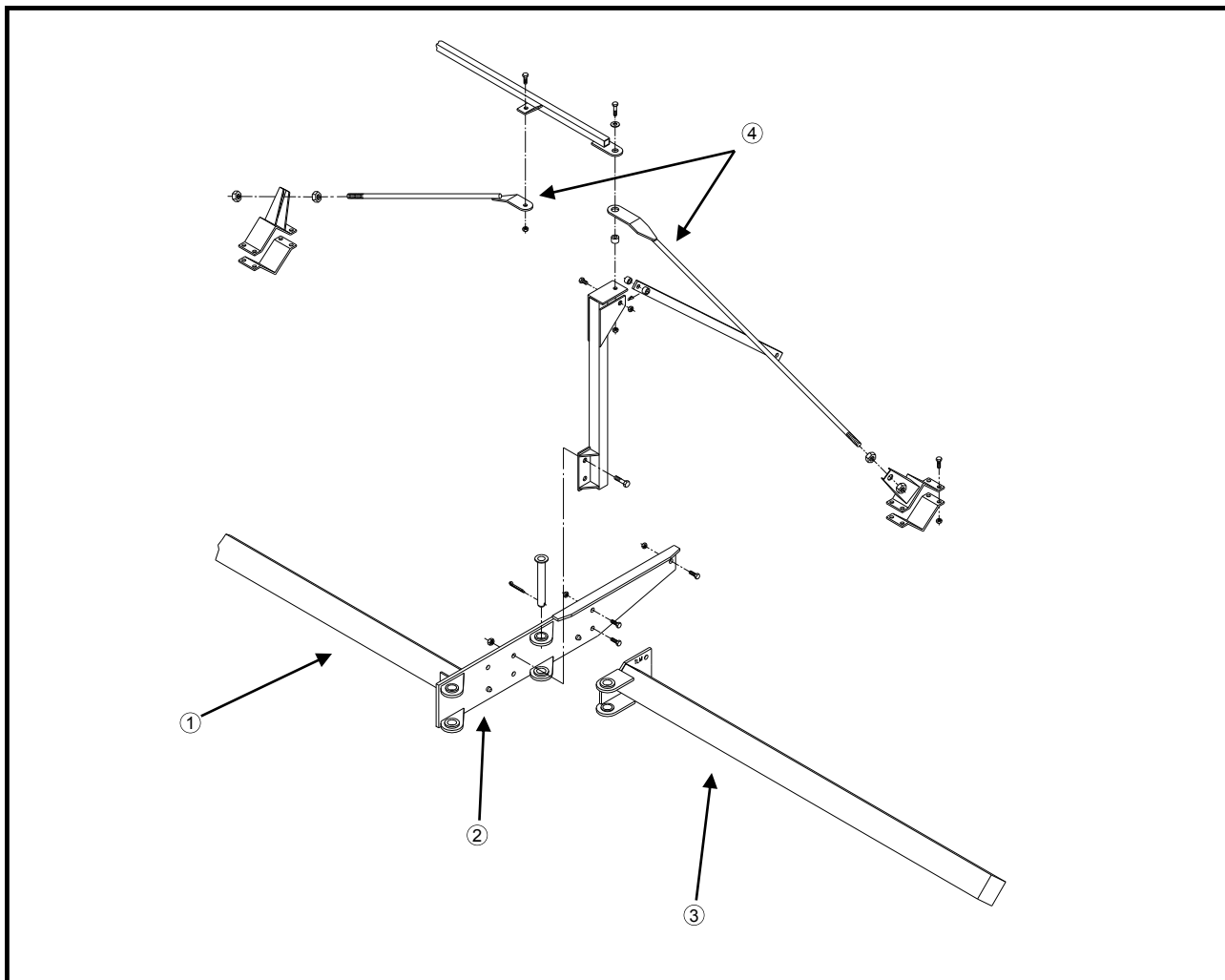

FIG 4.9

# IV. PREPARING TO OPERATE

## ATTACHING LIFT ASSEMBLIES

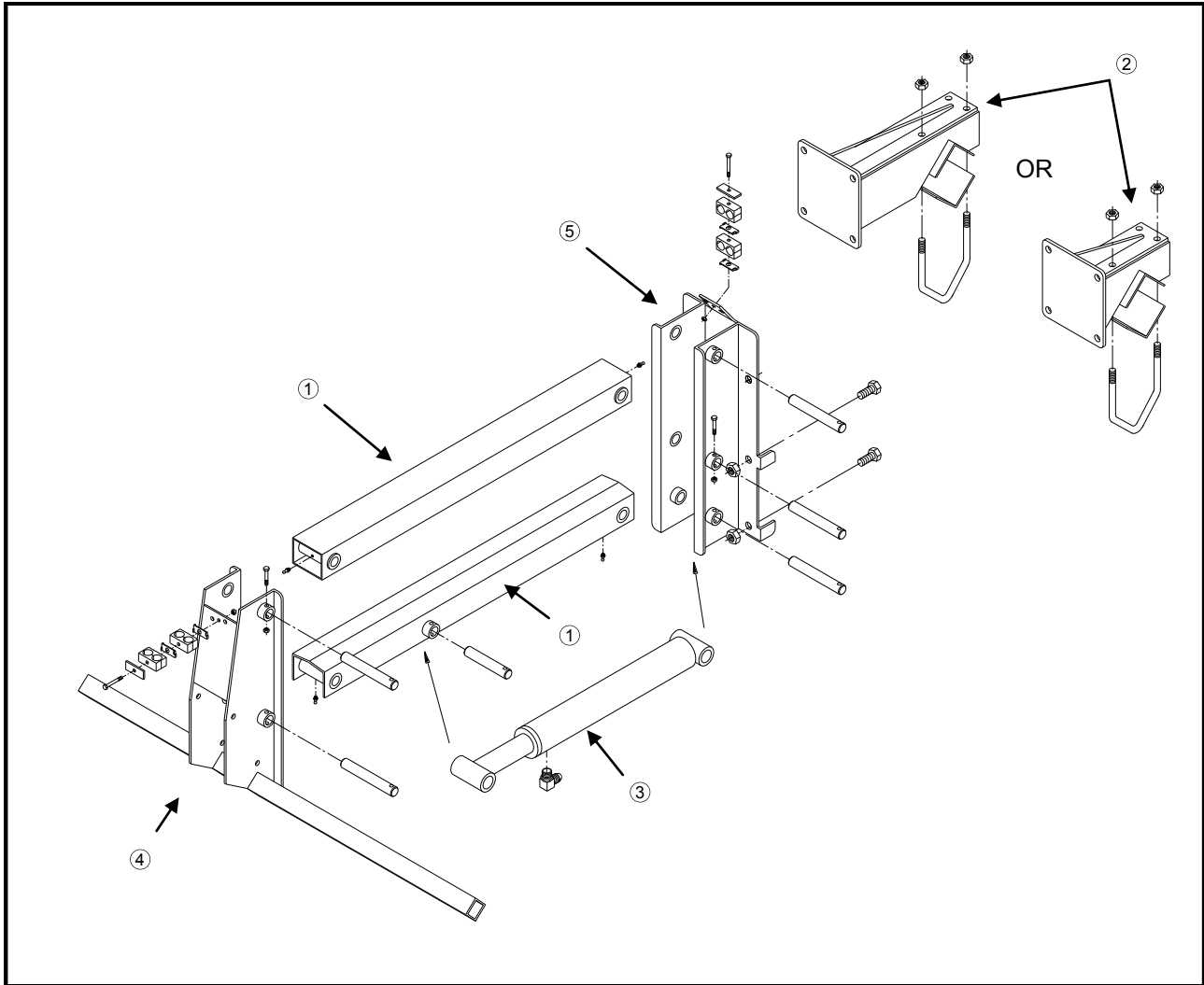

FIG 4.10

Refer to the Hagie 204SP Parts Manual for correct hardware when following these steps:

1. Attach the hoist column adapters (fig. 4.10, item 2) to the tool bar and the outriggers at the appropriate spacing. Refer to the Hagie 204SP Parts Manual for information on spacing.
2. Attach the toolbar mounting bracket (fig. 4.10, item 5) to the hoist column adapters.
3. Attach the lift arms (fig. 4.10, item 1) to the toolbar mounting bracket.
4. Attach the lift arm cylinders (fig. 4.10, item 3) to the lift arms.
5. Attach the toolbar weldment (fig. 4.10, item 4) to the lift arms.
6. Connect the hydraulic hoses to the lift cylinders. Refer to the Hagie 204SP Parts Manual for the correct hydraulic schematics.

# IV. PREPARING TO OPERATE

## ATTACHING QUAD PULLERS

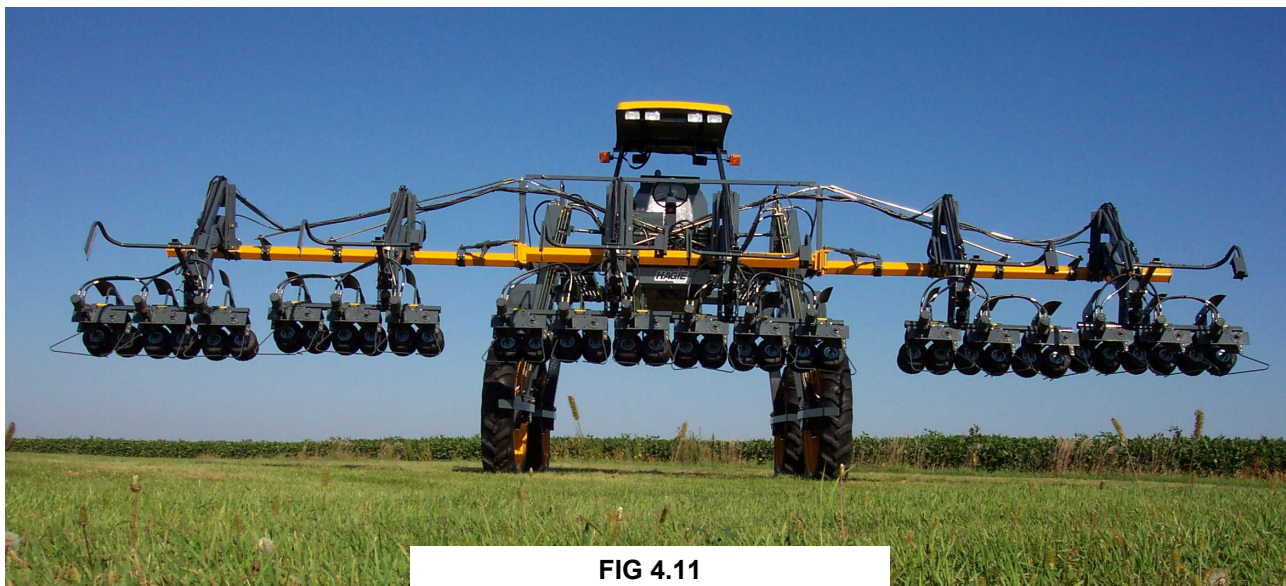

FIG 4.11

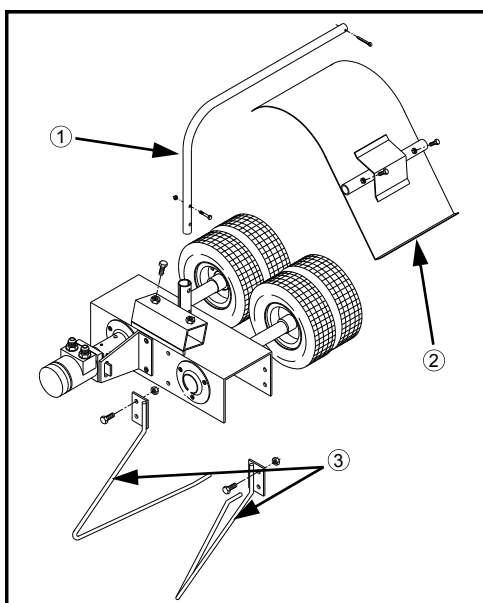

FIG 4.12

1. Attach the quad pullers to each lift arm tool bar (fig. 4.11).

**NOTE:**

Some quad pullers may come pre-assembled to the tool bar. In this case, you would attach them to the lift assembly.

2. Install the stalk guides to the quad puller head assembly (fig. 4.12, item 3).
3. Attach the deflector shield mount tube (fig. 4.12, item 1) and the deflector shields for right or left hand deflection (fig. 4.12, item 2).
4. Refer to page 29 for information about installing hydraulic hoses.
5. Adjust tire pressure to approximately 10 pounds.



FIG 4.13

**NOTE:**

Be sure all four tires have equal pressure. Check tire pressure daily.

# IV. PREPARING TO OPERATE

## QUAD PULLERS CONTINUED

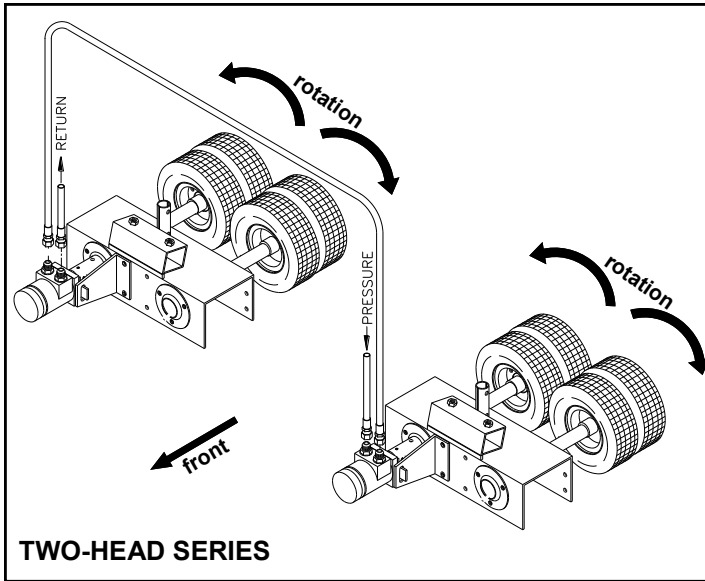

FIG 4.14

### Quad Puller Hydraulic Assembly

Hydraulic hoses on Quad Puller heads should be hooked up so tires rotate according to figure 4.14 and figure 4.15. Refer to the Hagie 204SP Parts Manual for correct hardware, hose lengths, and hydraulic schematic.

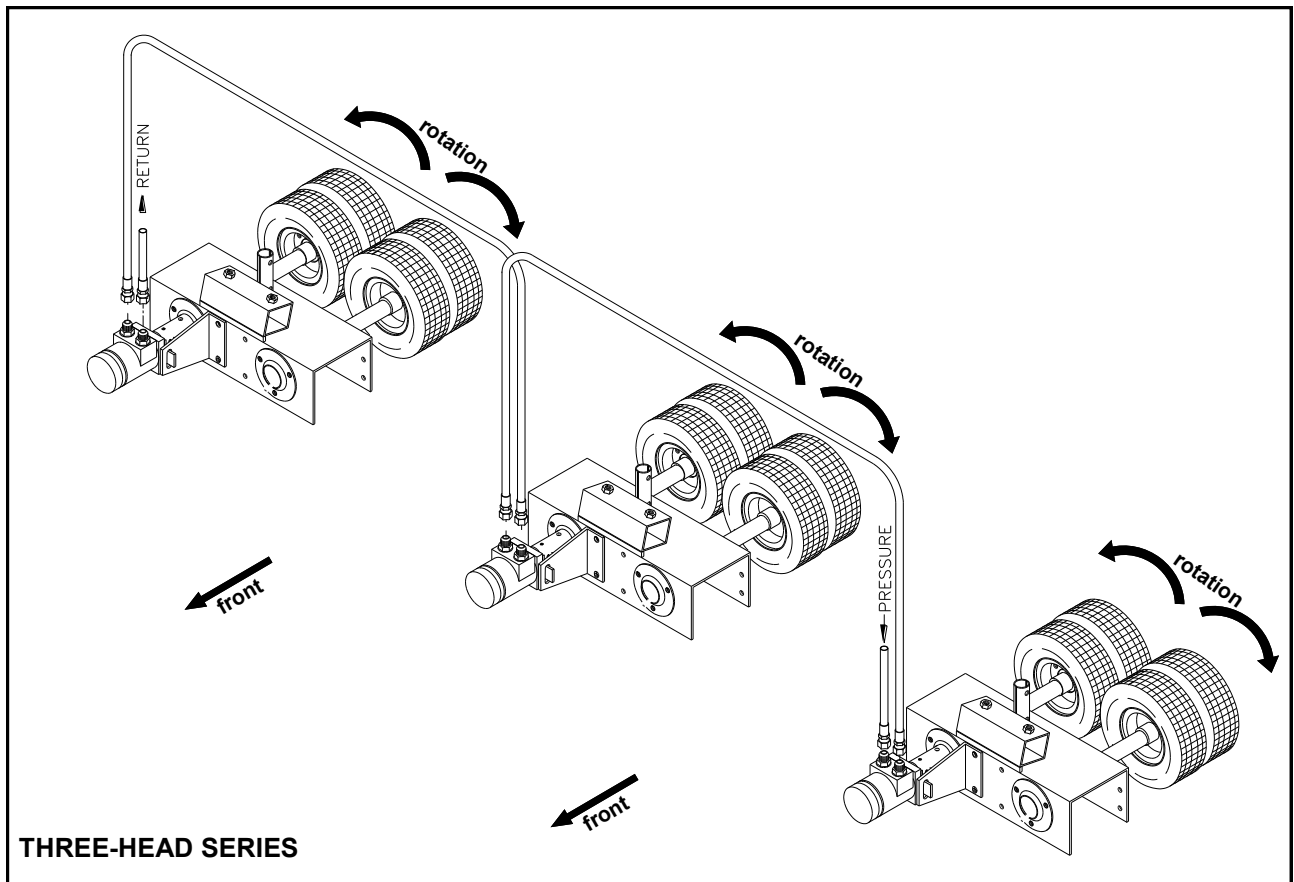

FIG 4.15



# IV. PREPARING TO OPERATE

## ATTACHING CUTTER HEADS



FIG 4.16



FIG 4.17

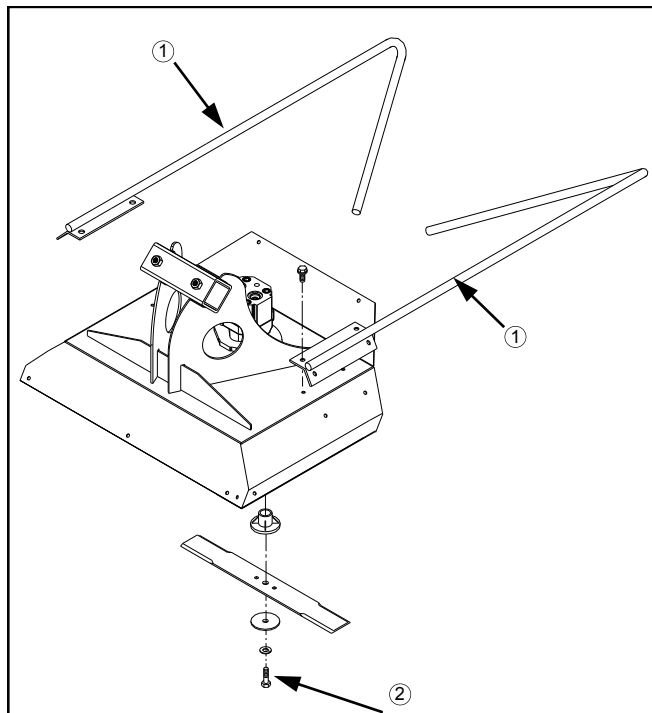

FIG 4.18

1. Attach the cutter head assembly to the tool bar (fig. 4.16).

### NOTE:

Some cutters may come pre-assembled to the tool bar. In this case, you would attach the assembly to the lift assembly.

2. Install the stalk guides to the cutter head assembly (fig. 4.18, item 1). Refer to the Hagie 204 SP Parts Manual for correct hardware.
3. Check and tighten, if necessary, the retaining bolt (fig 4.18, item 2).
4. Refer to pages 31-32 for information about installing hydraulic hoses.

# IV. PREPARING TO OPERATE

## CUTTER HEADS CONTINUED

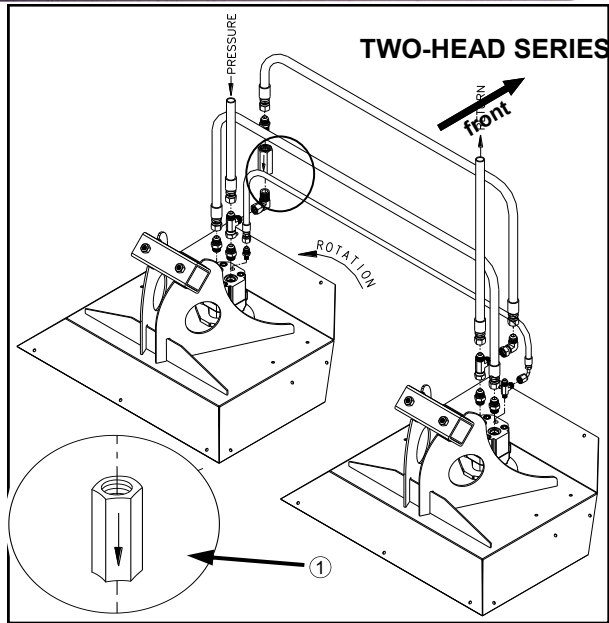

FIG 4.19

### Blade Rotation Left of Operator

Hydraulic hoses on cutter heads should be hooked up so blades on heads mounted left of operator rotate according to figures 4.19 and 4.20 (counter-clockwise from above). Refer to the Hagie 204SP Parts Manual for correct hardware, hose lengths, and hydraulic schematic.

#### NOTE:

Care should be taken when installing check valve (fig. 4.19, item 1) on cutter motor so the flow arrow is oriented correctly (either two-head or three-head series).

#### IMPORTANT:

Case drain hoses must be installed correctly on cutter motors to prevent motor damage. Refer to parts manual.

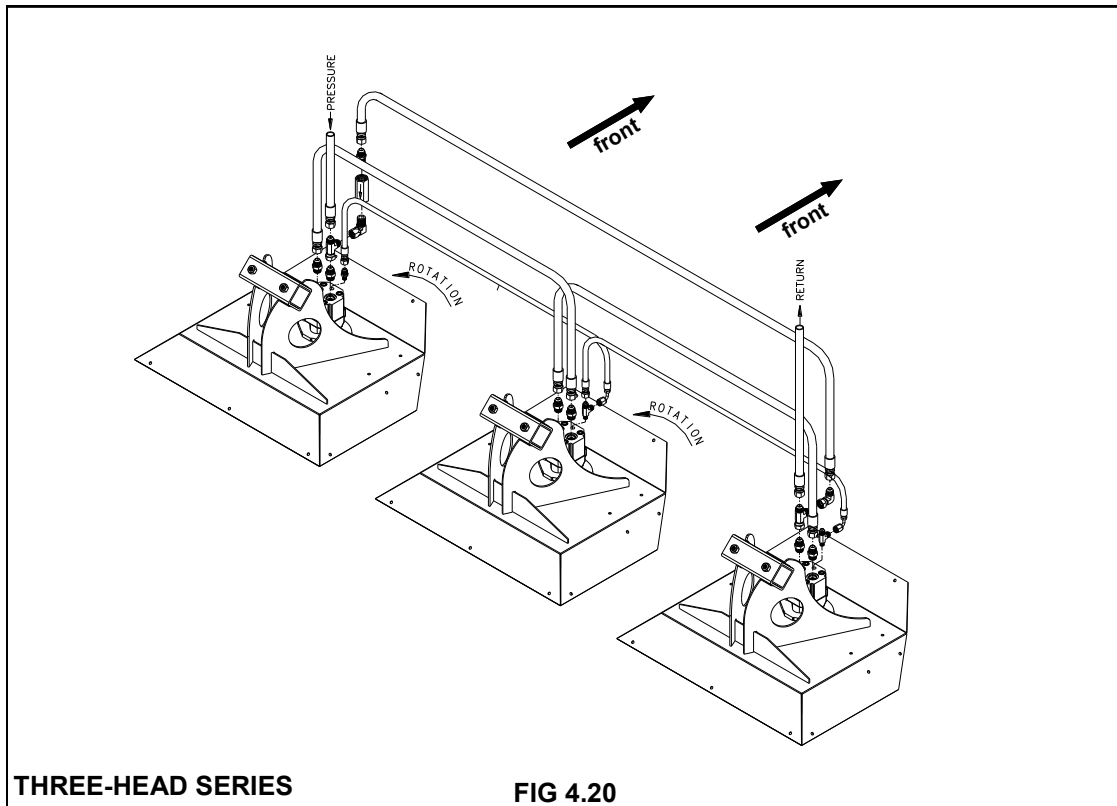

FIG 4.20

# IV. PREPARING TO OPERATE

## CUTTER HEADS CONTINUED

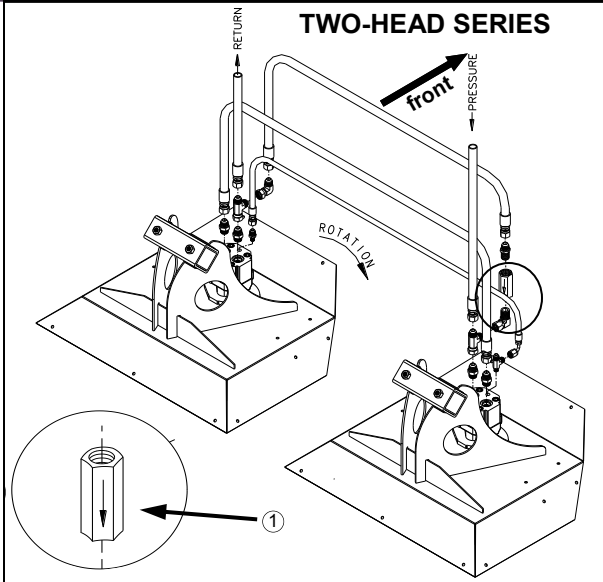

FIG 4.21

### Blade Rotation Right of Operator

Hydraulic hoses on cutter heads should be hooked up so blades on heads mounted right of operator rotate according to figures 4.21 and 4.22 (clockwise from above). Refer to the Hagie 204SP Parts Manual for correct hardware, hose lengths, and hydraulic schematic.

#### NOTE:

Care should be taken when installing check valve (fig. 4.21, item 1) on cutter motor so the flow arrow is oriented correctly (either two-head or three-head series).

#### IMPORTANT:

Case drain hoses must be installed correctly on cutter motors to prevent motor damage. Refer to parts manual.

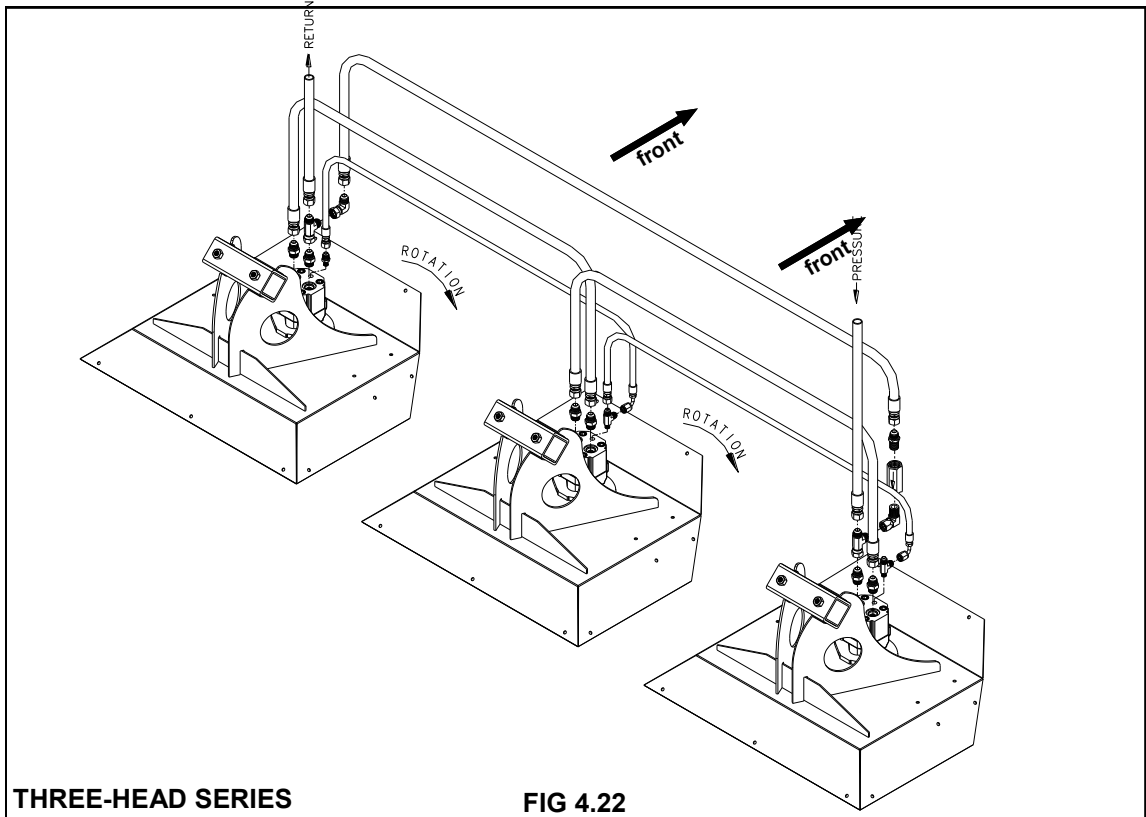

FIG 4.22

## IV. PREPARING TO OPERATE

### ATTACHING LS SYSTEM AND DEPTH COMMAND

1. Install Tasselrol®/LS sensor mount support weldment with the two nylon washers (fig. 4.23, item 2) in the forward-most hole of the tool bar (fig. 4.23, item 1).
2. Install the Tasselrol®/LS sensor mount (fig. 4.23, item 3) to the sensor mount support weldment (fig. 4.23, item 2).
3. Install the cable assembly according to the wire diagram in the Hagie 204SP Parts Manual.
4. Turn the ignition key switch to the "ON" position to check the sensor installation. DO NOT start the engine. See page 59 for more information about the LS sensor assembly.
5. Attach the depth command actuator (fig. 4.24) to the light sensor mount and the tool bar. See page 60.

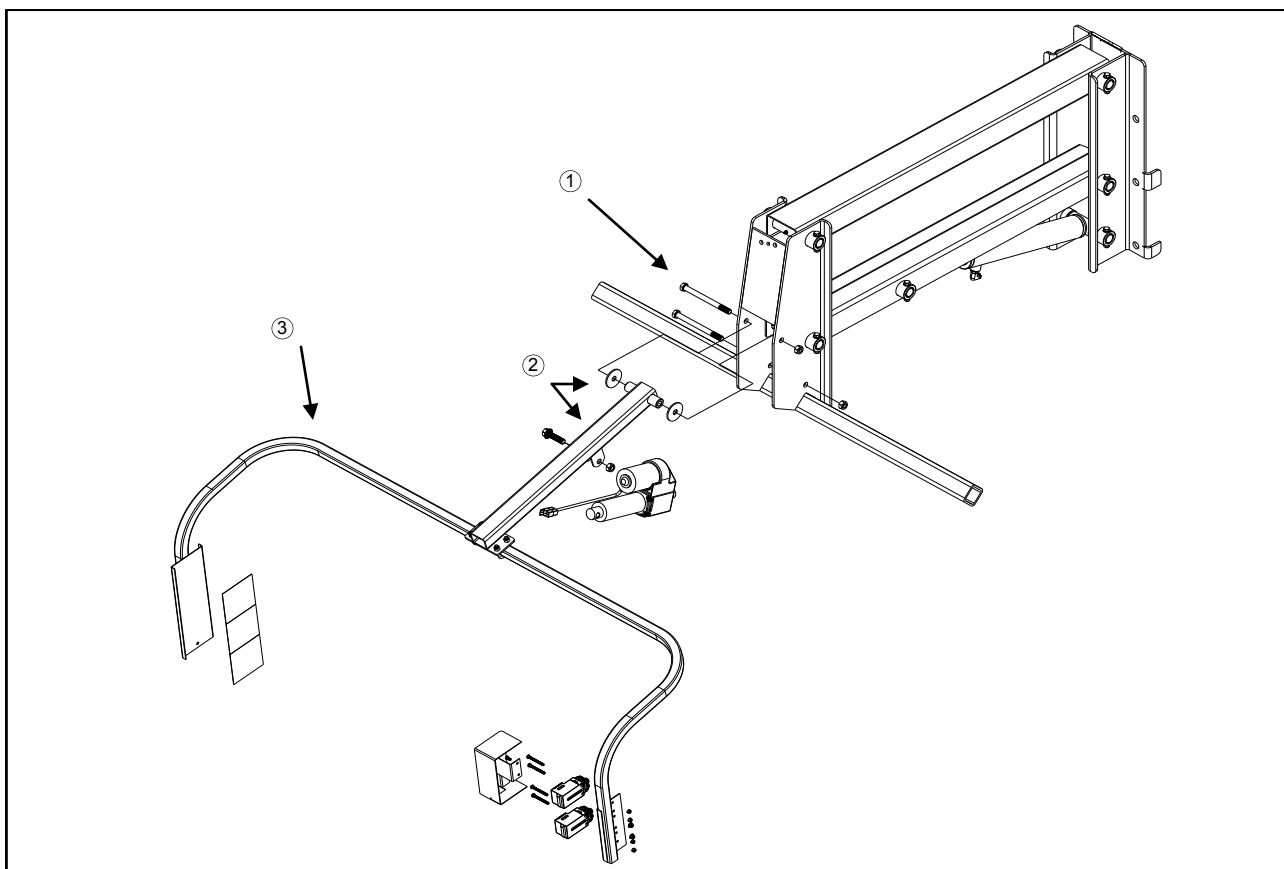

FIG 4.23

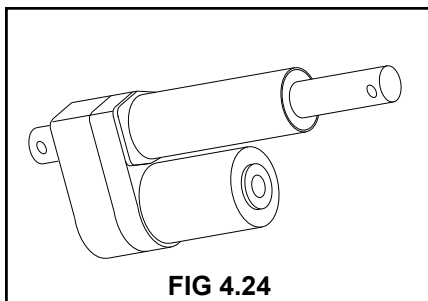

FIG 4.24

#### NOTE:

Over tightening of the sensor arm pivot mounting bolt (fig. 4.23, item 1) may cause the actuator to stall.

# V. OPERATING INFORMATION

---

## OPERATING THE ENGINE

Pre-operational Checks	Page Reference
1. Check the engine oil level. Do not operate the engine when oil is below the low mark on dipstick.	90
2. Check the coolant level in the radiator and the coolant overflow reservoir.	92-93
3. Check the hydraulic oil reservoir level.	90
4. Check cooling air intake screens.	95
5. Check engine drive belt.	107
6. Drain fuel/water separator.	99
7. Check the Filter Minder <sup>®</sup> .	96
8. Check for any oil or fuel leaks and correct if needed.	

## STARTING THE ENGINE



FIG. 5.1

Your Hagie 204SP has been equipped with a battery disconnect switch. The switch is located in the center rear of the machine on (fig. 5.1).

The switch disengages the battery therefore cutting all electrical power to the engine. Be sure that the switch is in the engaged position before starting the engine.



# CAUTION

Start engine from operator's seat only.  
When running engine in a building, be sure there is adequate ventilation.

### NOTE:

Do not use starting fluid when starting an engine. The use of too much starting fluid will cause engine damage.

# V. OPERATING INFORMATION

## STARTING THE ENGINE CONTINUED

1. Position hydrostatic control lever to “N” (neutral) position.
2. Apply parking brake (see page 40). When starting procedure is complete, release parking brake before moving.
3. Start the engine with the throttle at one-half speed.
4. Turn key to the “ON” position to check instruments (fig. 5.2).



Fig 5.2

5. Turn the ignition key switch to the start position to engage the starter. If the engine fails to start after 15 seconds, turn key to “OFF”, wait one minute and repeat the procedure. If the engine does not start after three attempts, check fuel supply system. Absence of blue or white exhaust smoke during cranking indicates no fuel is being delivered.
6. When engine starts, immediately reduce throttle lever setting to 1/3.
7. Inspect indicator lights and gauges for correct operation. If any lights or gauges do not operate, shut off engine and determine cause.
8. Always allow at least a five minute warm-up period before operating the engine at high RPM. This means the engine must reach operating temperature and oil pressure must stabilize in the normal operating range before it is run faster than an idle (1000 RPM or less). Cold oil may not flow in quantities adequate to prevent pump pump seizure. A longer warm up period may need to be allowed in cold weather.



## CAUTION

Electrical system is 12 volt negative ground. When using booster with jumper cables, precautions must be taken to prevent personal injury or damage to electrical parts.

1. Attach one end of jumper cable to positive terminal of booster battery and other end to positive terminal of vehicle battery connected to starter motor.
2. Attach one end of second cable to negative terminal of booster battery and other end to vehicle frame away from battery. Do not attach to cab or cab support.
3. To remove cables, reverse above sequence exactly to avoid sparks. See operator's manual for additional information.

650982

# V. OPERATING INFORMATION

## HYDROSTATIC DRIVE

The power for the Hagie 204SP is derived from a Cummins diesel engine (fig 5.3). The hydrostatic power system consists of a Sauer/Danfoss heavy duty variable displacement pump and variable displacement wheel motors.

A manual control lever connected to the pump's swashplate controls the amount and direction of oil flow to the motors determining the speed and direction of the machine.

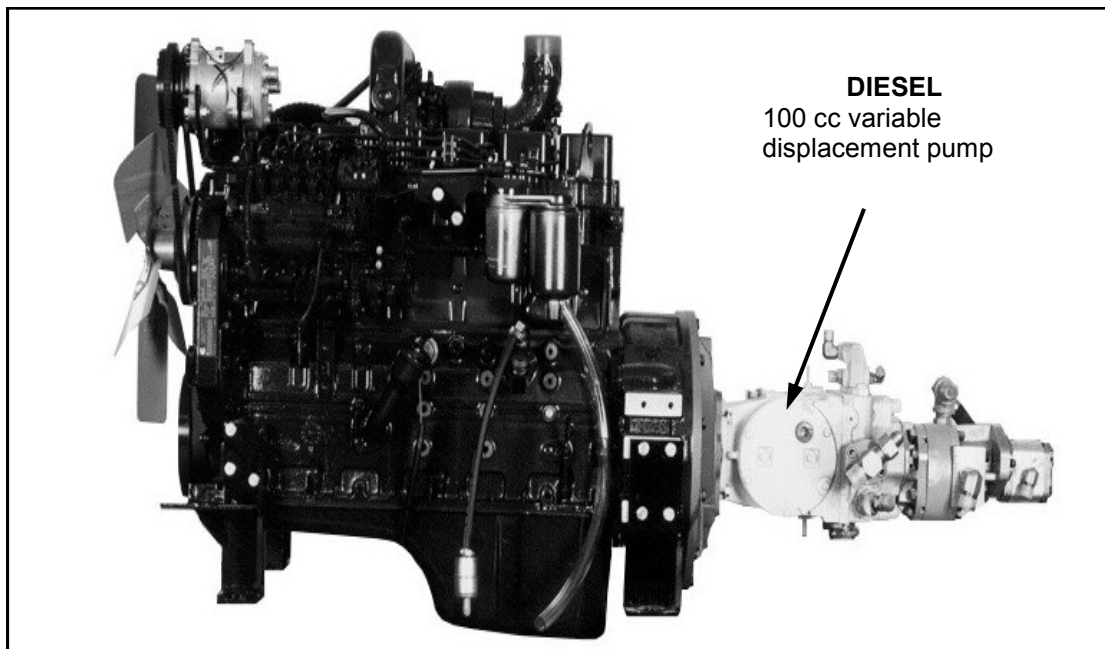

FIG 5.3

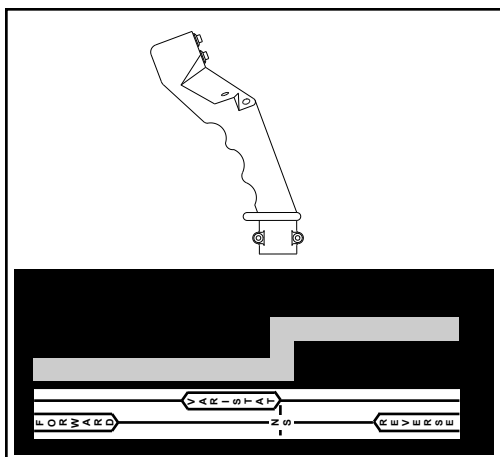

FIG 5.4

### NOTE:

Never operate the detasseler at anything less than full recommended throttle.

1. Open the throttle slowly to the maximum recommended engine speed setting.
2. To move forward, slowly push the hydrostatic control lever (fig. 5.4) forward. The farther the control lever is moved, the faster the detasseler will travel. To stop, slowly pull the lever to the "N" (neutral) position.
3. To reverse the machine, slowly pull the hydrostatic control lever back. To stop, slowly push the lever to the "N" (neutral) position.
4. Before turning off the engine, reduce engine speed and allow the engine to idle at least three minutes.

# V. OPERATING INFORMATION

## HYDROSTATIC SYSTEM

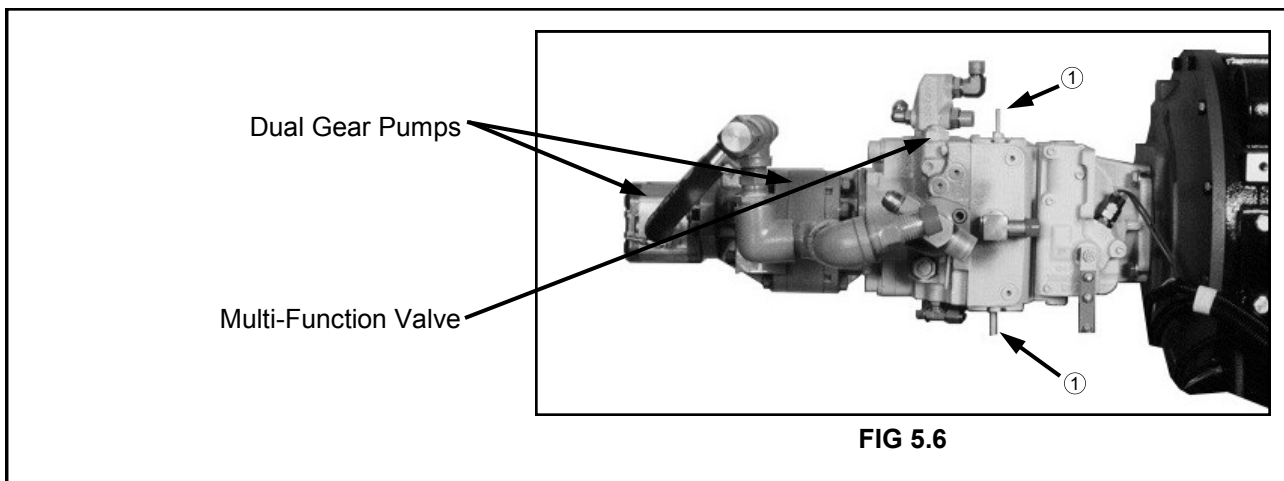
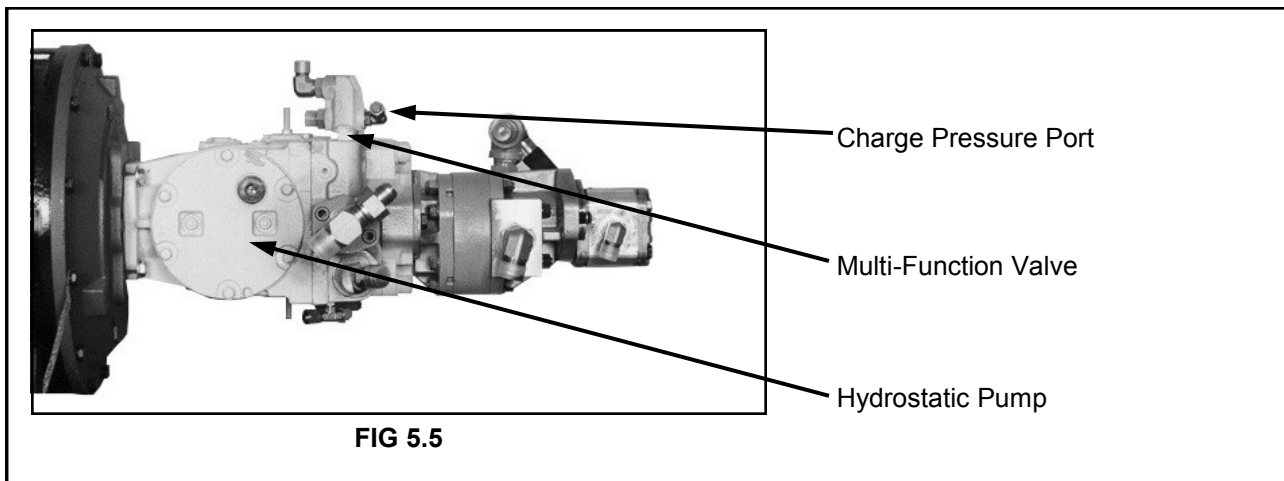

### Displacement Limiter

The Sauer/Danfoss Series 90 variable pump is equipped with a mechanical displacement (stroke) limiter (fig. 5.6, item 1)

**NOTE:**

The limiter is factory set and requires no further adjustment. If adjustments are made without contacting the Hagie Customer Support Department, damage may result to the system and void the warranty.



# V. OPERATING INFORMATION

## HYDROSTATIC SYSTEM CONTINUED

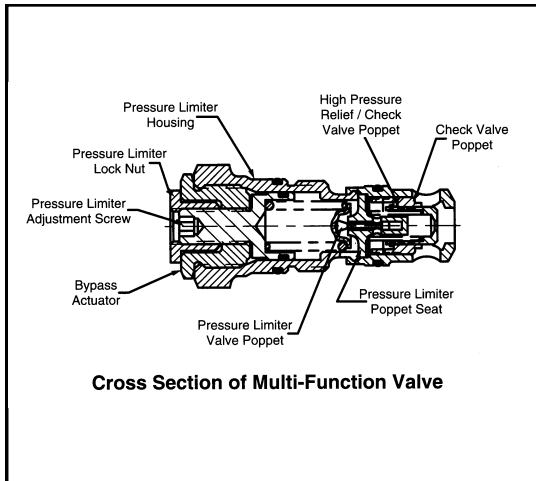

FIG 5.7

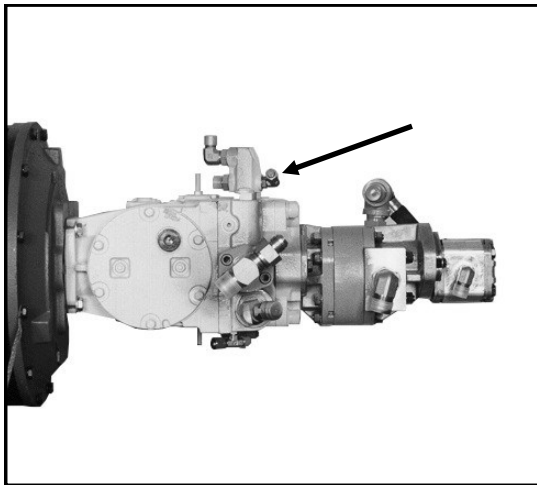

FIG 5.8

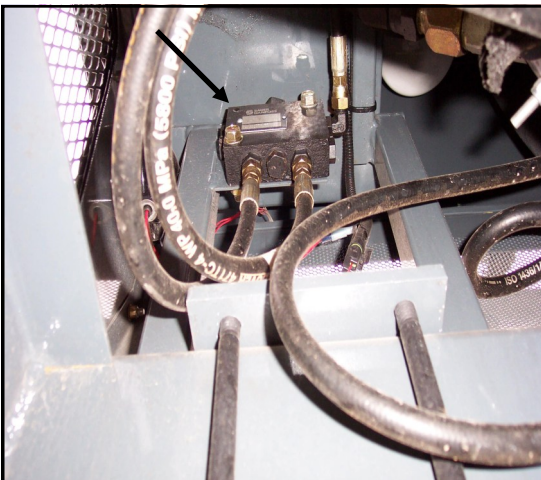

FIG 5.9

## Multi-Function Valves

Each Series 90 pump is equipped with two multi-function valves (fig. 5.7). These valves incorporate the system check valve, the pressure limiter valve, the high pressure relief valve, and the bypass valve.

When the pre-set pressure is reached, the pressure limiter system acts to rapidly de-stroke the pump in order to limit the system pressure.

## Charge Pressure

To monitor the closed loop system (hydrostatic pump), install a 500 PSI pressure gauge at the charge pressure port (fig. 5.8). Start the engine and open the throttle to full RPM. The charge pressure should be between 348 and 365 PSI. If it is below the required pressure, contact the Hagie Customer Support Department.

## Loop Flushing Valve

The hydrostatic pump is equipped with a loop flushing valve (fig. 5.9). It is used to remove fluid from the hydrostatic system for cooling and removal of contamination.

### NOTE:

The loop flushing valve has been factory set. DO NOT adjust. Damage to the system may result if adjustment is made without contacting the Hagie Customer Support Department.

# V. OPERATING INFORMATION

## HYDROSTATIC SYSTEM CONTINUED

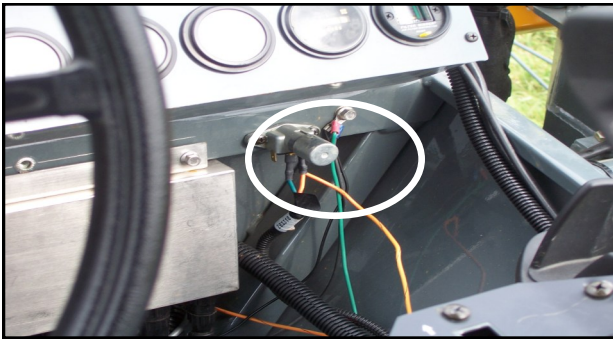

FIG 5.10

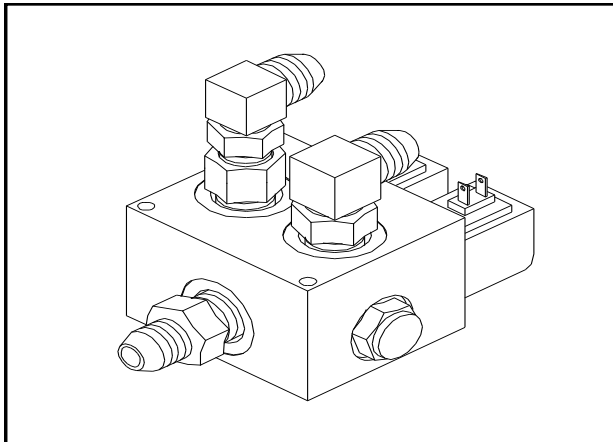

FIG 5.11

### NOTE:

To prevent hydraulic loop damage, do not operate the front traction valve continuously or while traveling over 4 MPH. Activate the front traction valve only when needed. Shut the traction valve switch off when clear of problem area.

## TRACTION VALVE

The Hagie 204SP comes equipped with special hydraulic valves for increased traction (one in the front hydraulic loop and one in the rear hydraulic loop). These valves greatly reduce spin-out if muddy conditions prevail, or if wheels lose traction for any reason. The valve in the rear loop is active at all times. The valve in the front loop (fig 5.11) is activated by a switch on the frame of the operator's station, to the right of the depth command control panel. (fig 5.10). When the traction valve is activated an indicator on the instrument panel will light up (fig. 5.12). Do not activate at speeds above 4 MPH.



FIG 5.12

## WHEEL MOTORS

The Hagie 204SP has been equipped with Sauer/ Danfoss variable speed wheel motors. The motors are controlled by a SHIFT switch located on the console (fig. 5.13)

When the switch is in the "ON" position, you are in high gear which gives you a higher speed for better performance on the road.

When the switch is in the "OFF" position, you are in low gear which gives you lower speed for better handling in the field.



FIG. 5.13

# V. OPERATING INFORMATION

## HYDROSTATIC SYSTEM CONTINUED



FIG 5.14



FIG 5.15



FIG 5.16



FIG 5.17



FIG 5.18

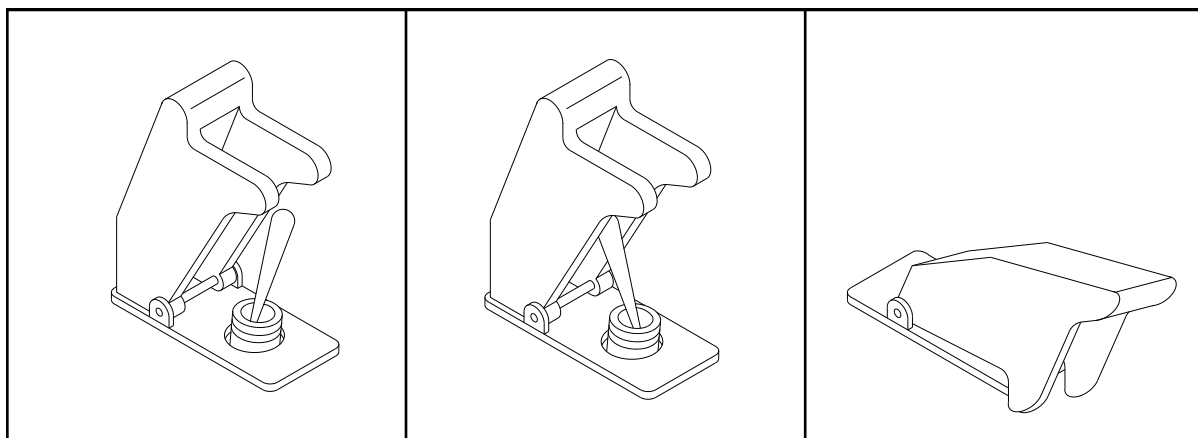

A

B

C

FIG 5.19

## Parking Brake

The brakes are controlled by charge pressure. When the engine is shut off or if the charge pressure is below 150 PSI the brakes will become activated. To set the brakes while the engine is running, activate the switch located on the right-hand switch panel (fig. 5.14 and 5.15).

Lift the RED switch cover as shown in figure 5.19A. To engage the brakes, flip the switch forward to the "ON" position as shown in figure 5.19B. To release the brakes, close the RED cover and this in turn will flip the brake switch to the "OFF" position as shown in figure 5.19C. Always return the brake switch to the "OFF" position before moving the detasseler.

# V. OPERATING INFORMATION

## HYDRAULIC SYSTEM

The auxiliary hydraulic system is an open type directly mounted behind the heavy duty variable displacement pump. This system consists of dual gear pumps that supply the required hydraulics to operate the full time power steering unit, lift cylinders, and various cutters or pullers.

After supplying each of these systems, the

hydraulic oil is sent to the oil cooler in front of the engine coolant radiator. Here it is cooled and then sent back to the hydraulic oil reservoir.

The front, larger gear pump (fig. 5.20, item 1) supplies only the cutters or pullers. The rear, smaller gear pump (fig. 5.20, item 2) supplies power steering and the lift cylinders.

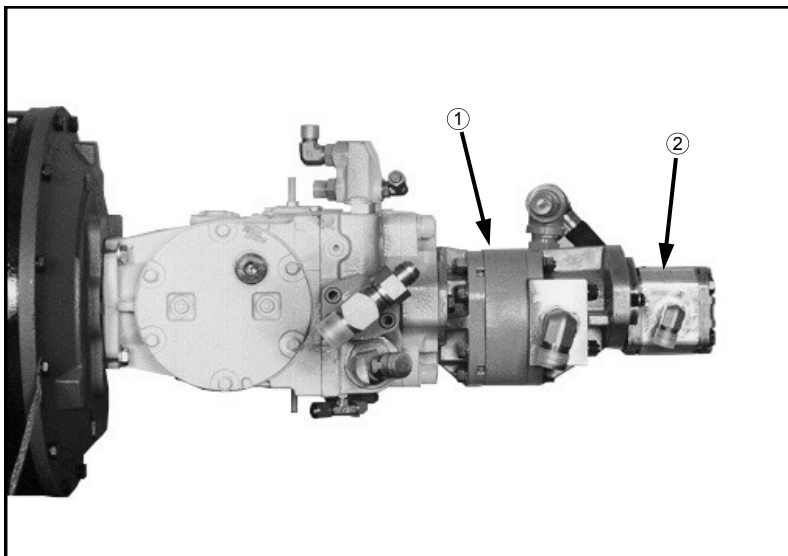

FIG 5.20

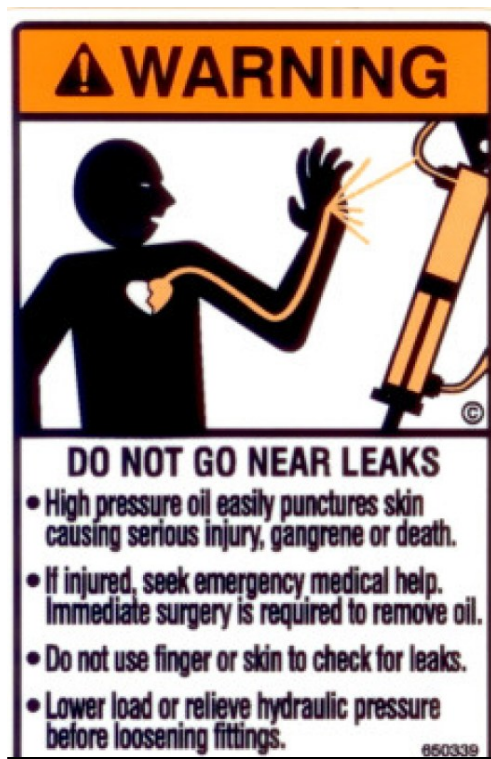

FIG. 5.21

### NOTE:

Immediately shut down engine if low level hydraulic oil light comes on (fig. 5.21).

# V. OPERATING INFORMATION

## HYDRAULIC SYSTEM CONTINUED



FIG 5.22

### Power Steering

The full-time power steering system consists of a hydraulic steering motor (mounted on the end of the steering wheel shaft) which is connected to a pair of double-action steering cylinders (fig. 5.22, item 1) mounted to both of the front steering arms and outer leg weldments. This system is powered by one of the hydraulic dual gear pumps driven by the detasseler's engine. Since these gear pumps are sensitive to engine RPM (the higher the RPM the higher the oil flow), it is best to always operate the detasseler at full recommended RPM to ensure maximum steering responsiveness.

### Electro-Hydraulic Valves

The electro-hydraulic valve (fig. 5.23, item 1), located on the front toolbar controls the lift cylinders in

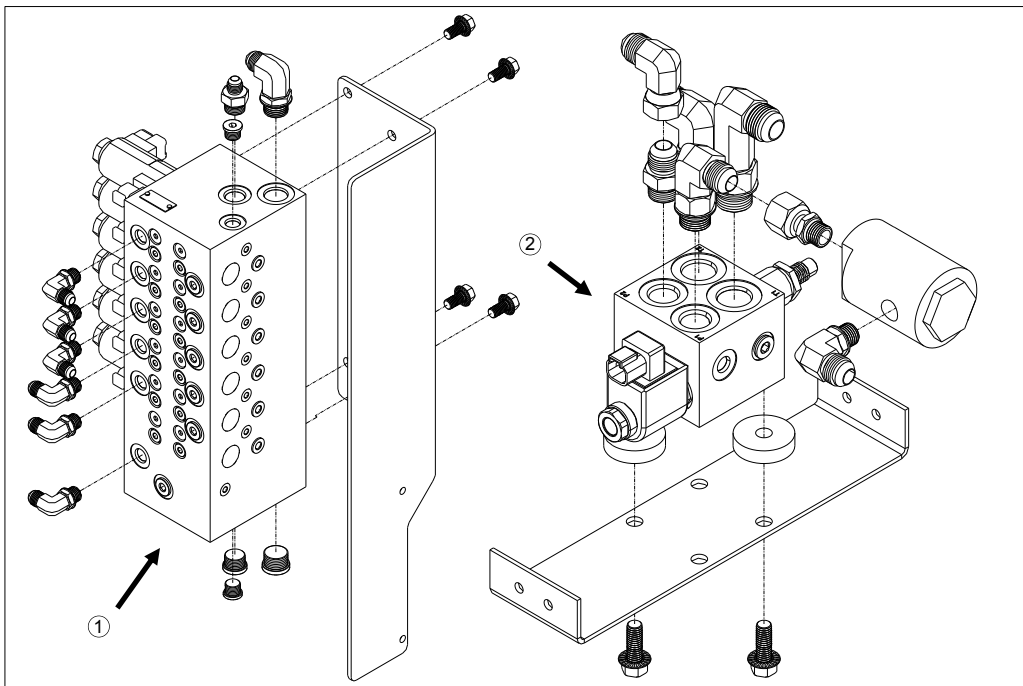

FIG 5.23

their upward and downward movements. The dump valve (fig. 5.23, item 2), located directly under the operator's seat, is the main valve which controls the amount of pressure going to the lift valve. The dump  
(continued on next page)

# V. OPERATING INFORMATION

## HYDRAULIC SYSTEM CONTINUED

(continued from previous page)

valve is preset at the factory to 2200 psi.

To check the psi, install a 3000 psi pressure gauge on the inlet of the dump valve (fig. 5.25, item 1). If any further adjustment is required, contact Hagie Customer Support Department.

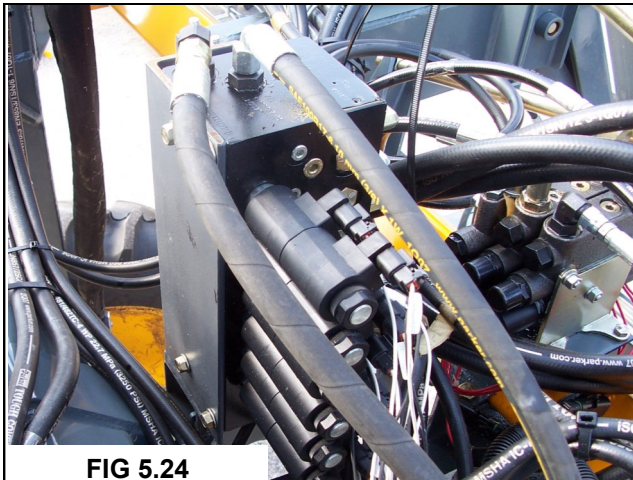

FIG 5.24

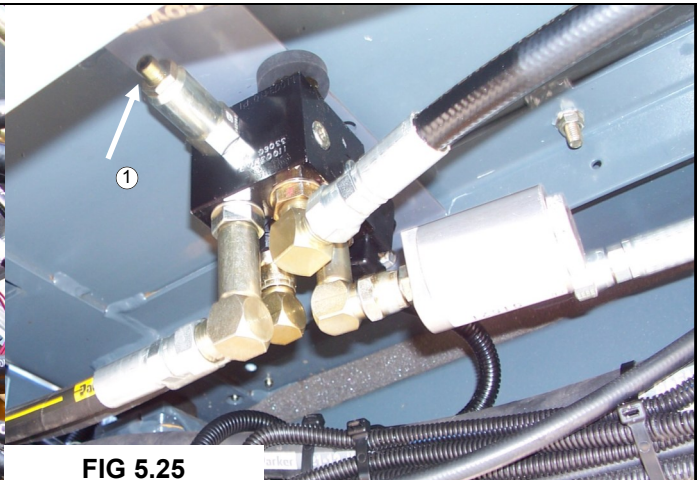

FIG 5.25

## Lift Cylinders

To adjust the height of each detasseling head assembly, cylinders mounted on each lift unit (fig. 5.26) are connected to a console-mounted lift control (fig. 5.27). The controls are switchable from

manual to automatic.

For information about operating or adjusting parameters in the Tasselrol<sup>®</sup>/LS automatic lift controls see pages 45-58.

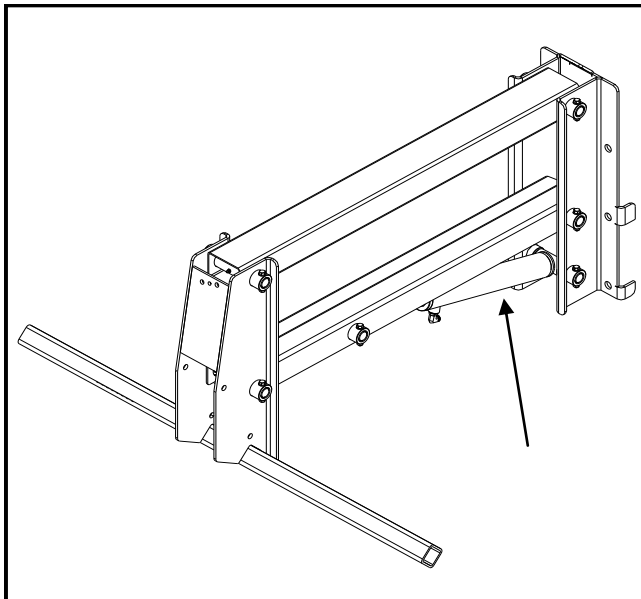

FIG 5.26

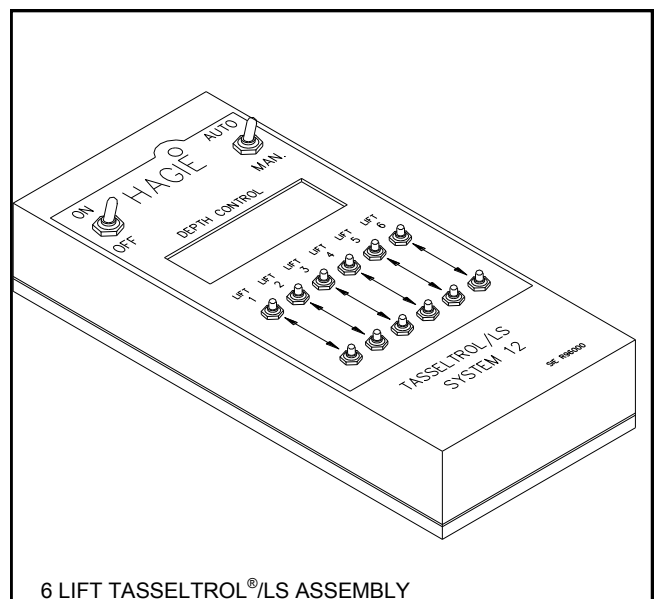

FIG 5.27

# V. OPERATING INFORMATION

## HYDRAULIC SYSTEM CONTINUED

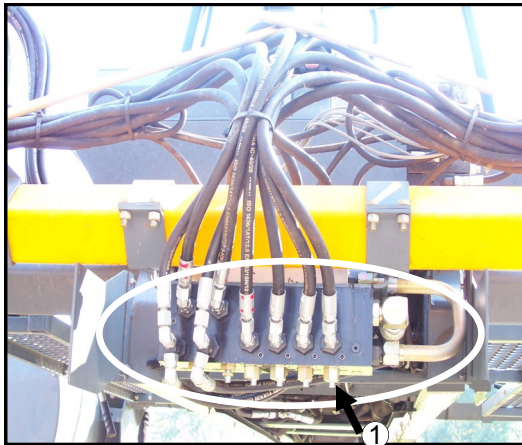

FIG 5.28

### Detasseling Heads

The hydraulic motors on the detasseling heads (fig. 5.30) are controlled by a master switch (fig. 5.29, item 1) and individually turned on and off with a row of switches mounted on the control panel to the right of the operator's seat (fig. 5.29, item 2). To open the solenoid on any of the motor control valves (fig. 5.28) which activates the motors, flip the corresponding switch (es) away from the operator. To shut any or all motors off, flip the corresponding switch(es) toward the operator.

Each set of motors is controlled with an adjustable needle valve (fig. 5.28, item 1) that restricts hydraulic flow to the hydraulic motors so they don't over-speed and become damaged. This valve is preset at the factory and requires no adjustment.

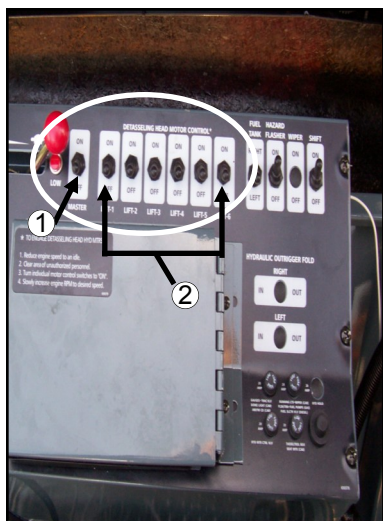

FIG 5.29

**\* TO ENGAGE DETASSELING HEAD HYD MTRS:**

1. Reduce engine speed to an idle.
2. Clear area of unauthorized personnel.
3. Turn individual motor control switches to "ON".
4. Slowly increase engine RPM to desired speed.

650379

Activate hydraulic motors while engine speed is at an idle, then increase engine RPM to operating speed.

If the operator is out of the seat for 3 seconds while the detasseling heads are running, these functions will stop. The detasseling heads will remain off until, the operator sits back into the seat and turns the master control switch off and then on again.



FIG 5.30

# V. OPERATING INFORMATION

## SETTING UP THE HAGIE TASSELTRÖL®/LS SYSTEM 12™

### Initial Set Up



FIG. 5.31

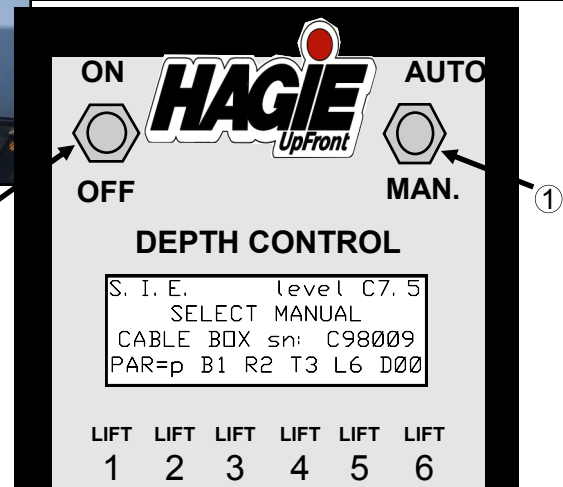

FIG 5.32

### 1. Enter the Parameter Mode:

Select **AUTO** by placing the **AUTO/ MAN.** switch (fig. 5.32, item 1) in the **AUTO** position. Now turn on the **DEPTH CONTROL** (fig. 5.31) by placing the **ON/OFF** switch (fig. 5.32, item 2) in the **ON** position.

In the LCD display window (fig. 5.33), there will be four lines. The top line displays the program level. The second line will flash **SELECT MANUAL** as a warning that you are about to enter the parameter adjusting mode.

The current parameter settings are displayed on the bottom line of the window. The values for **B, R,**

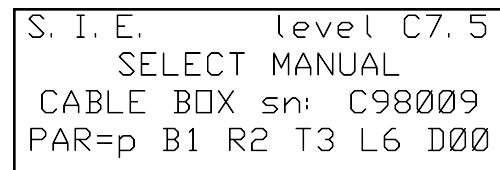

FIG. 5.33

**\*NOTE:** Machines with a Tasseltröl® software version level C8.7 and greater have an enhancement that allows the operator to set the lift speeds for the auto mode functions. (See instructions 5 and 7)



# V. OPERATING INFORMATION

## HAGIE TASSELTROL® CONTINUED

T, and D are typically set as shown in figure 5.34.

The machine type will vary from **o**, **p**, or **c** depending on the valve system. Also, the **L** will vary depending on the number of lifts on the machine.

### 2. Match the machine valve type:

Press the **LIFT 1 up** button under the **PAR** on the LCD display window **two times** (fig. 5.34) and the display will show you the machine type that is selected (fig. 5.35). The “**o**”, “**p**”, or “**c**” just to the right of the **NEXT** on the bottom line of the LCD display indicates the type of machine. To change the type of machine, press the **LIFT 2 up** button that is located under this item. The display will now change to the **SELECT MACHINE TYPE** screen (fig. 5.36).

Select the type of machine that this unit is installed on. **For a machine prior to 2007, with the original valve system press the LIFT 4 button under “o”.** If the machine has the new proportional valves press the **LIFT 5** button under the “**p**”. If the machine is a 2007 or newer STS combination sprayer– detasseler with the proportional valves, press the **LIFT 6** button under the “**c**”.

The screen will now revert back to the **SELECT MANUAL** screen with the machine type that you have just selected displayed on the bottom line.

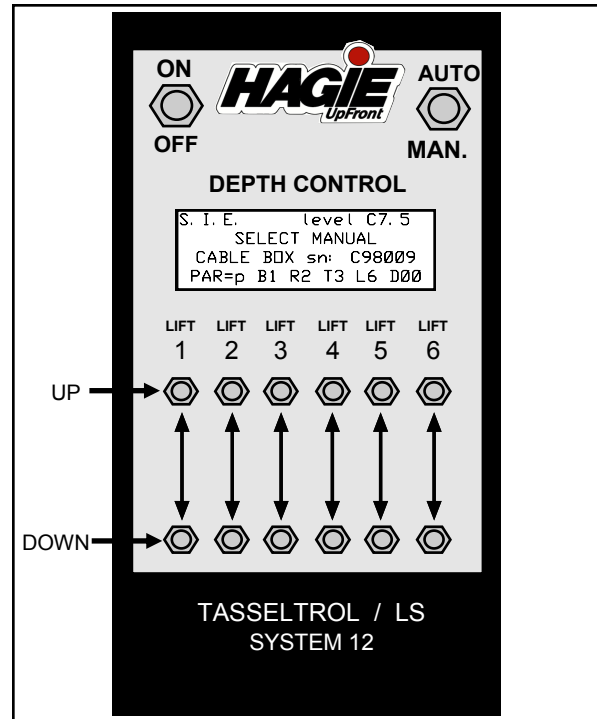

FIG 5.34

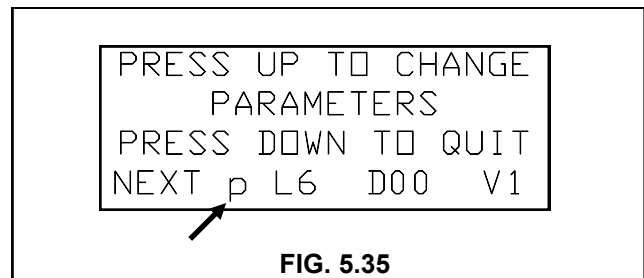

FIG. 5.35

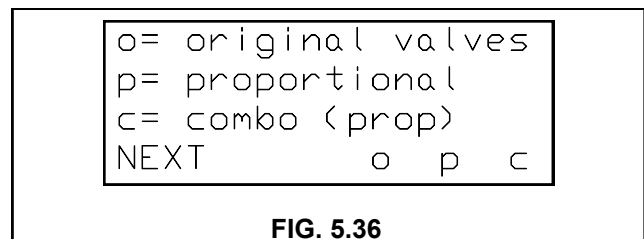

FIG. 5.36

# V. OPERATING INFORMATION

## HAGIE TASSELTRÖL® CONTINUED

### 3. Match how many lifts are on the machine:

(If you are not in parameter mode, do Step 1 first and then do this step)

Press the **LIFT 1 up** button under the **PAR** on the LCD display **two times** and the display will show you how many lifts are turned on. In figure 5.37, item 1, the display shows **L6** indicating that all 6 lifts are on.

To change the number of lifts to match your machine, press the **LIFT 3 up** button under the **L** (fig. 5.37, item 1). This will display the **LIFTS: ON—OFF** screen (fig. 5.38).

Now press the **up** button under the lift that you want to turn on or off. In this example, lift 5 has been turned off. After selecting which lifts are to be on or off, press the **LIFT 1 down** button **two times** to exit this screen and save the new parameter setting.

### 4. Establish “D” and “V”:

(If you are not in parameter mode, do step 1 and then do this step)

Press the **LIFT 1 up** button under the **PAR** on the LCD display **two times** and the display will show the current setting of the **Dwell** (fig. 5.37, item 2) for all up and the **Valve compensation** (fig. 5.37, item 3) as either **1 = on**, or **0 = off**.

The **D** value indicates how many seconds that the lifts will travel up after the **ALL-UP** button (see page 56) on the hydrostatic handle is pressed momentarily. The time can be changed by pressing the **LIFT 4 up** button. It is normally set to **zero** before delivering the machine to the customer, but can be

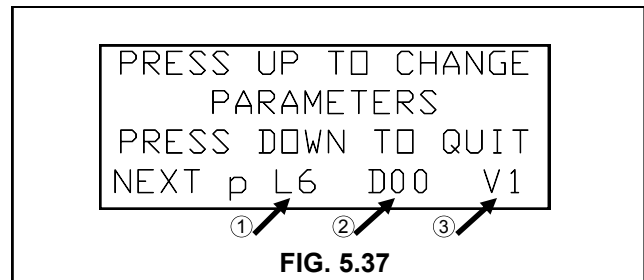

FIG. 5.37

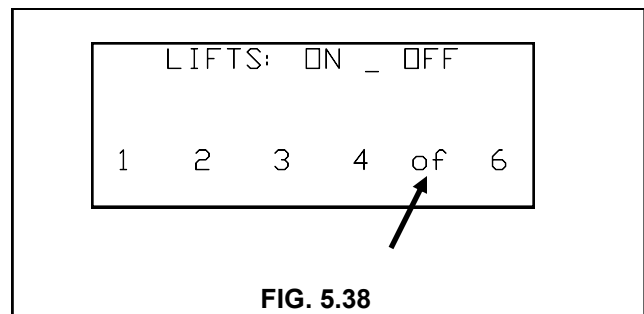

FIG. 5.38

set to a value of **20** while adjusting the machine valves. Pressing the **LIFT 4 up** button will add 5 seconds to the value each time until **D25** and then will return to **D00**.

When the value is set at **D00**, the up motion stops as soon as the hydrostatic handle **ALL-UP** button is released. If the value is set to anything greater than **D00**, the **ALL-UP** will only need to be pressed momentarily and the lifts will continue the up move until the parameter has been reached.

The **V** value indicates whether or not the valve automatic compensation is performed. Press the **LIFT 6 up** button to change this value. This is normally left at **V1**.

# V. OPERATING INFORMATION

## HAGIE TASSELTRÖL® CONTINUED

### 5. Set the lift up speeds:

(if you are not in parameter mode, do step 1 first and then do this step)

Press the **LIFT 1 up** button under the **PAR** on the LCD display screen **three times** and the display will show the current setting of the up speed for an auto move\*, a manual move and an all-up move with a value from **01** to **10**.

With the value set to **01**, the lifts will move very slowly. This setting of **01** is useful for adjusting the offset of the valves to get all the lifts to move at the same speed. Typically these values are set to **05** for a fairly fast speed. The values can be changed by pressing the up and down buttons under the **AUTO**, **MAN** or **ALL** (fig. 5.39).

The values can be saved by pressing the **LIFT 1 down** button to exit this screen and save the new parameter setting.

### 6. Set the lift up offset:

(if you are not in parameter mode, do step 1 first and then do this step)

Press the **LIFT 1 up** button under the **PAR** on the LCD display screen **four times** and the display will show the current setting of the **UP OFFSET** for the first three lifts (fig. 5.40). Pressing **NEXT** again will show the offset setting for the last three lifts. The **UP OFFSET** for each valve can be set from **-19** to **+20** as needed to get that lift speed to match the speed of the other lifts. The more positive the number, the faster the lift will move. Typically the offset is initially adjusted at a very slow speed by setting the **LIFT UP SPEED** to either **01** or **02**.

Exit the parameter mode and check the speed of

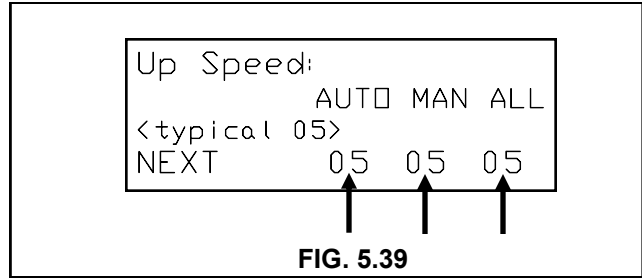

FIG. 5.39

each lift by moving it manually with the up/ down buttons. Now correct the fastest and slowest lifts to match the average speed by changing the offset value with the up/down buttons for that lift while in the **LIFT UP OFFSET** parameter. When finished setting the offset values, return the speed setting back to about **05**.

Now with all the lifts at their lowest points, select **AUTO**. Now press the **ALL-UP** button on the hydrostatic handle so they will all move up at the same time. Correct the values for any lifts that are not close to the speed of the others.

The values can be saved by pressing the **LIFT 1 down** button to exit this screen and save the new parameter setting.

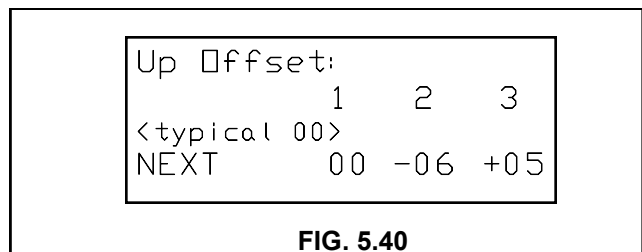
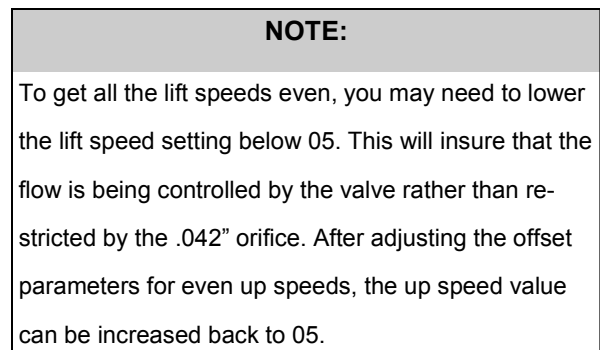

FIG. 5.40

# V. OPERATING INFORMATION

## HAGIE TASSELTRÖL® CONTINUED

### 7. Set the lift down speeds:

(If you are not in parameter mode, do step one first and then do this one)

Press the **LIFT 1 up** button under the **PAR** on the LCD display screen **six times** and the display will show the current setting of the down speed for an auto move\*, a manual move and an all– resume move with a value of **01** to **10**.

With the value set to **03** the lifts will move a little slower. This setting of **03** is useful for adjusting the offset of the values for getting all the lifts the same speed. Typically these values are set to **05** for a fairly fast speed. The values can be changed by pressing the up and down buttons under the **AUTO**, **MAN** or **ALL** (fig. 5.41).

The values can be saved by pressing the **LIFT 1 down** button to exit this screen and save the new parameter setting.

### 8. Set the lift down offset:

(if you are not in parameter mode, do step 1 first and then do this one)

Press the **LIFT 1 up** button under the **PAR** on the LCD screen **seven times** and the display will show the current setting of the down offset for the first three lifts (fig. 5.42). Pressing **NEXT** again will show the offset setting for the last three lifts.

The down offset for each valve can be adjusted for a value from **-19** to **+20**. The more positive the number the faster the lift will move. Typically the offset is initially adjusted at a slightly slower speed by setting the lift down speed to **03**.

Exit the parameter mode and check the speed of each lift by moving it manually with the up/ down

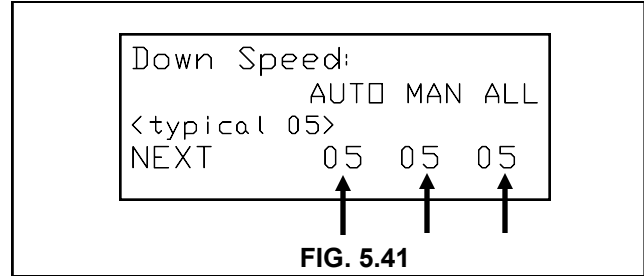

FIG. 5.41

buttons. Now correct the fastest and slowest lifts to match the average speed by changing the offset value with the up/down buttons for that lift while in the **DOWN OFFSET** parameter. When finished setting the offset values, return the speed setting back to about **05**.

Now with all the lifts at their highest points, select **AUTO** so all the lifts will move down together. Correct the values for any lifts that are not close to the speed of the others.

The values can be saved by pressing the **LIFT 1 down** button to exit this screen and save the new parameter setting.

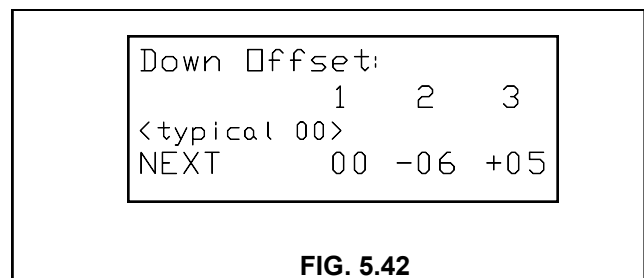

FIG. 5.42

#### NOTE:

Once the parameters have been set, very little adjustment will be required.

# V. OPERATING INFORMATION

## HAGIE TASSELTRON<sup>®</sup> CONTINUED

### SETTING UP THE HAGIE TASSELTRON<sup>®</sup>/LS SYSTEM 12<sup>™</sup>

#### LS System 12<sup>™</sup> Parameters



FIG 5.43

Once you have set the operating parameters you can adjust the response parameters. These parameters are used to adjust the response of the controller and **SELDOM** need changing. The parameter values are stored in flash memory and will be retained even when no battery power is present. Your programmable control box is factory preset with the following parameter defaults:

**BOTTOM PARAMETER – B1** See page 53 to reprogram the bottom parameter.

**RESPONSE PARAMETER – R2** See page 51 to reprogram the response parameter.

**TOP PARAMETER – T3** See page 52 to reprogram the top parameter.

These parameters will always be displayed until the control box is reprogrammed. Once reprogrammed, the new values for the parameters will appear in the window of the control box.

To program the unit, first select the response parameter (page 51). If further adjustment is required for top and/or bottom parameters, see pages 52 and 53.

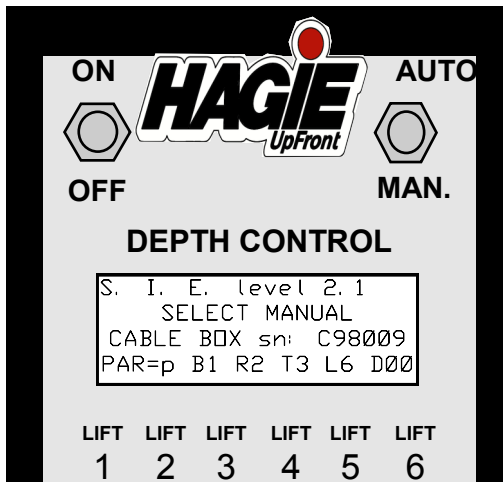

FIG 5.44

# V. OPERATING INFORMATION

## HAGIE TASSELTROL® CONTINUED

### TASSELTROL® RESPONSE PARAMETER

The response parameter is used to adjust the response time of both photocells. How quickly the down motion starts when no corn is detected by either the top or bottom cells, and how quickly the up motion is stopped when corn is no longer detected by the top cell, can be changed by selecting **R1**, **R2**, **R3**, or **R4**. More corrections will occur with **R1** selected, and fewer corrections with **R4** selected. The normal or default value for this parameter is **R2**, but can be set to any desired value.

Use the response parameter to adjust overall correction activity and to compensate for ground speed. If the pullers are moving too quickly and frequently, the response parameter can be increased toward **R4**. If the pullers are too slow to respond to

changes in the corn depth, decrease the parameters toward **R1**. Generally this parameter can be left at **R2**.

To display the response parameter, select **AUTO** and turn the control box power on. Wait three seconds for the **SELECT MANUAL** message, press the **UP** button under **PAR**. Now press the **UP** button under the **R** value.

1. The active value of the parameter is indicated by it blinking on and off, while the other three choices are displayed continuously.
2. To select a new value for the parameter, press the **UP** button under the desired choice.
3. After selecting one of the four choices, press the **LIFT 1 down** button to escape this parameter.
4. To save new values and escape the parameter mode, press the **LIFT 1 down** button a second time.

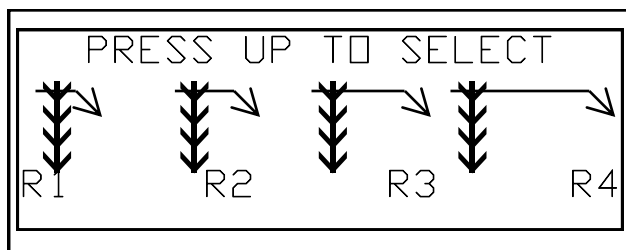
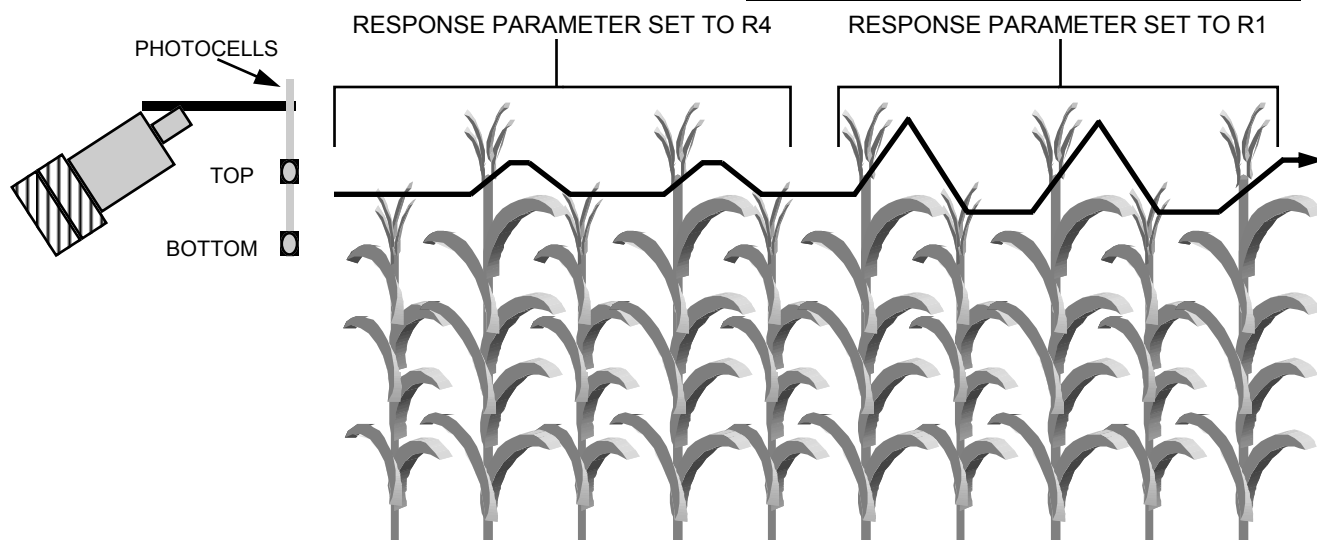

FIG 5.45

#### NOTE:

See page 59 for more information regarding the LS photolights.



# V. OPERATING INFORMATION

## HAGIE TASSELTROL® CONTINUED

### TASSELTROL® TOP PARAMETER

The top parameter is used to adjust the sensitivity of the top photocell. The top photocell starts the up motion when its lights path is blocked by corn. How much corn it has to see before starting the up move can be changed by selecting one of the four values **T1**, **T2**, **T3**, or **T4**. With **T1** selected, less corn is required to start an up move. The normal or default value for this parameter is **T3**, but can be set to any desired value.

If the pullers move up too easily when a taller stalk of corn passes, increase the parameter toward **T4**. If the pullers stay deep too long when taller corn passes, decrease the parameter toward **T1**. Generally this parameter can be left at **T3**.

To display the top parameter, select **AUTO** and

turn the control box power on. Wait three seconds for the **SELECT MANUAL** message. Press the **UP** button under **PAR**. Now press the **UP** button under the **T** value.

1. The active value of the parameter is indicated by it blinking on and off, while the other three choices are displayed continuously.
2. To select a new value for the parameter, press the **UP** button under the desired choice.
3. After selecting one of the four choices, press the **LIFT 1 down** button to escape this parameter.
4. To save new values and escape the parameter mode, press the **LIFT 1 down** button a second time.

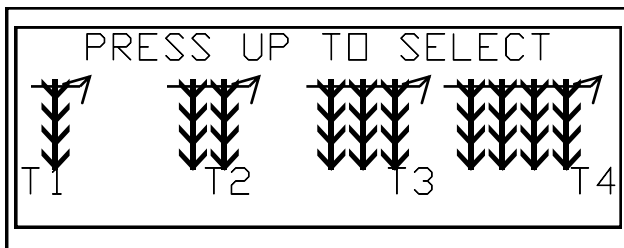
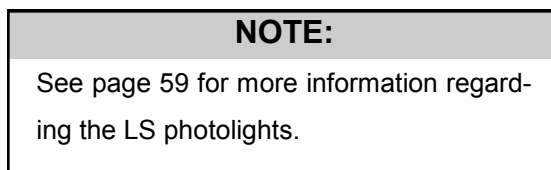
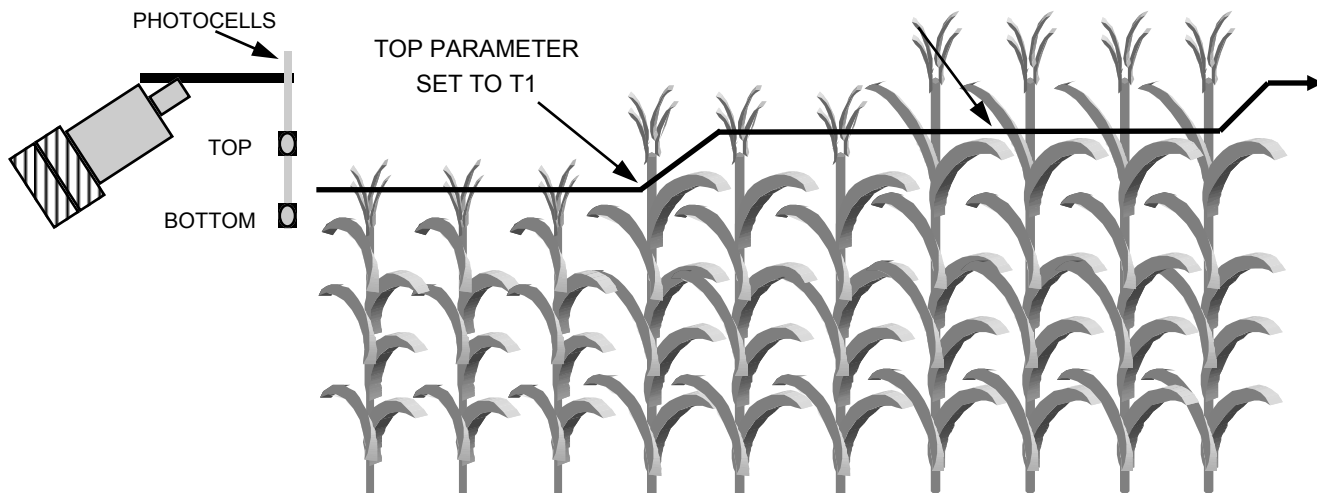

FIG 5.46



TOP PARAMETER SET TO T4



# V. OPERATING INFORMATION

HAGIE TASSELTROL® CONTINUED

## TASSELTROL® BOTTOM PARAMETER

The bottom parameter is used to adjust the sensitivity of the bottom photocell. The bottom photocell stops the down motion when its light is blocked by corn. How much corn it has to see before stopping the down move can be changed by selecting one of the four values **B1**, **B2**, **B3**, or **B4**. With **B1** selected the down move will stop as soon as corn is detected. With **B4** selected the down move will continue a little longer. The normal or default value for this parameter is **B1**, but can be set to any desired value.

If the pullers run too shallow after moving down into shorter corn, increase the parameter toward **B4**. If the pullers move too deep when going into shorter corn or oscillate between the top and bot-

tom photocells, decrease the parameter toward **B1**. Generally this parameter can be left at **B1**.

To display the bottom parameter, select **AUTO** and turn the control box power on. Wait three seconds for the **SELECT MANUAL** message. Press the **UP** button under **PAR**. Now press the **UP** button under the **B** value.

1. The active value of the parameter is indicated by it blinking on and off, while the other three choices are displayed continuously.
2. To select a new value for the parameter, press the **UP** button under the desired choice.
3. After selecting one of the four choices, press the **LIFT 1 down** button to escape this parameter.
4. To save new values and escape the parameter mode, press the **LIFT 1 down** button a second time.

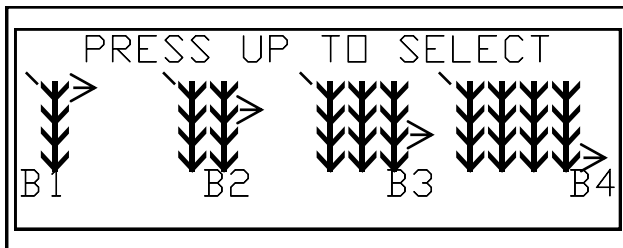
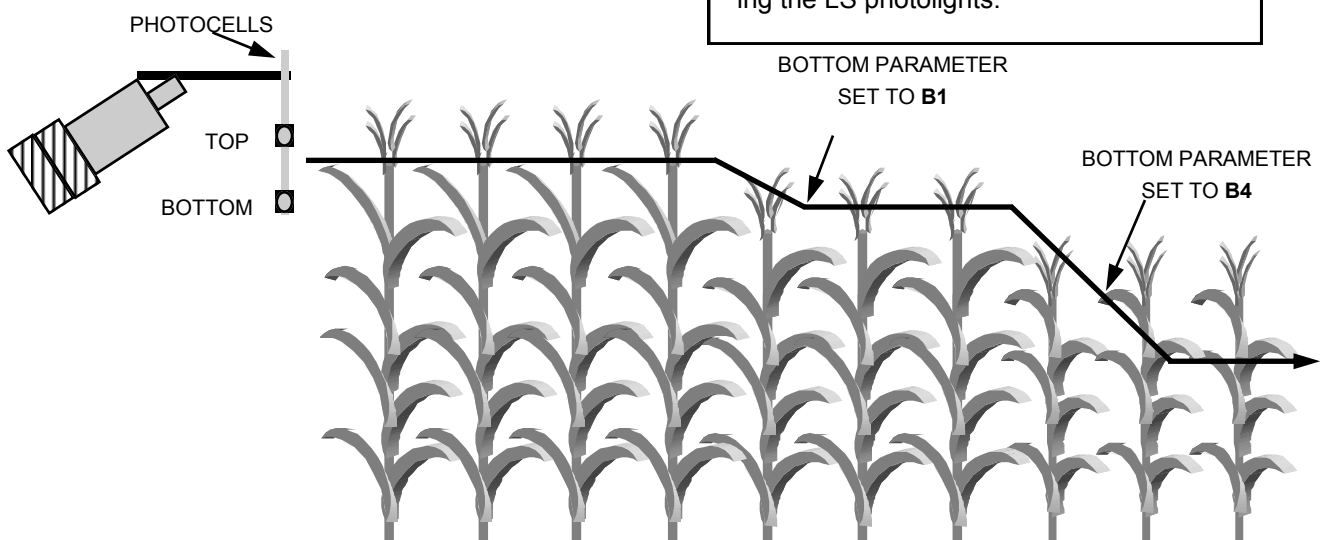

FIG 5.47

**NOTE:**  
See page 59 for more information regarding the LS photolights.





# V. OPERATING INFORMATION

## HAGIE TASSELTROL® CONTINUED

### OPERATING THE HAGIE TASSELTROL®/LS CONTROL



FIG 5.48

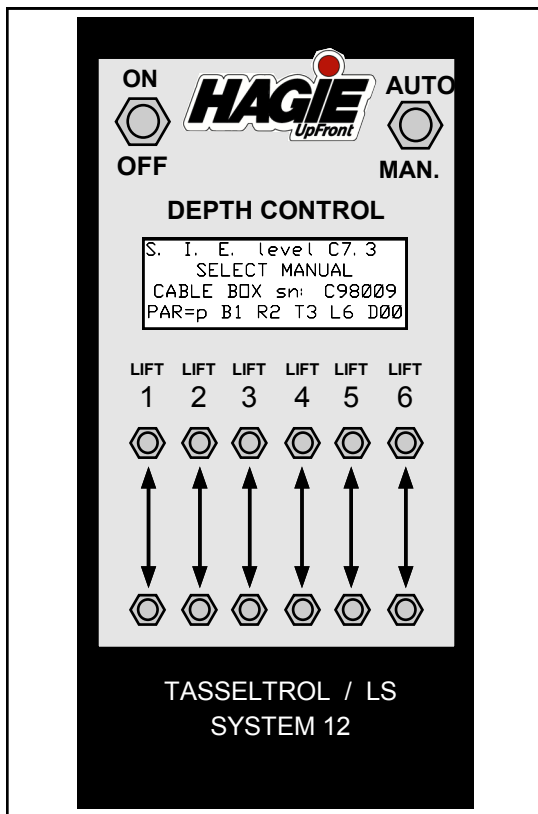

FIG 5.49

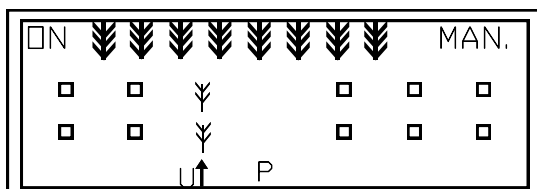

FIG 5.50

To use the control box with its normal parameter setting, use the following procedures. To adjust the given parameters, see pages 45-58.

1. From the operator's seat, turn the ignition to the **ON** position.
2. Turn the control box power switch to the **ON** position.
3. Turn the **AUTO/MANUAL** switch to **MANUAL**. At this time the display will read "MANUAL" in addition to other information identifying the control box.
4. Press the individual row switches for up and down movement. An arrow in the display will indicate direction of each lift assembly. **P** indicates pressure, **UP** only for "o" type machines, and **UP** and **DOWN** both in "p" and "c" type machines.
5. If the **AUTO/MANUAL** switch is left in the **AUTO** position when the unit is first started, the display will tell you to **SELECT MANUAL**. After you have selected **MANUAL** switch back to the **AUTO** position.
6. To override the system, press the desired **UP** switch to raise the attachment. When the switch is released, the system will go back into the **AUTO** mode.
7. If the ignition is left on and the **AUTO/MANUAL** switch is left in the **AUTO** position, the down coils on the electro-hydraulic valve will lose power after 45 seconds. To re-activate, move the **AUTO/MANUAL** switch from **AUTO** to **MANUAL** and back to **AUTO**.
8. The control box is set up with a feature so that if a unit loses contact during operation in the **AUTO** mode, the unit will automatically rise. If this should happen, switch to the **MANUAL** mode and determine the cause for malfunction.

# V. OPERATING INFORMATION

HAGIE TASSELTRÖL® CONTINUED

## SHORT CORN OPERATION

When operating the LS system, always select **MANUAL** when first entering the field. Once you have maintained your operating speed and the cutting and/or pulling depth, select **AUTO**. When you come to an area where the corn is very short, such as a low spot in the field, you may want to switch to the **MANUAL** position until you reach taller corn.

Always switch to the **MANUAL** position before

you reach the end rows (fig. 5.51). This will allow the cutter or puller heads to maintain their cutting or pulling height when re-entering the field (fig. 5.51), then you may switch back to **AUTO**.

You may choose to use the **ALL UP/HOLD** function instead of switching to manual. This function will raise all the detasseling heads in one motion. For more information on the **ALL UP/HOLD** function refer to pages 47 and 56.

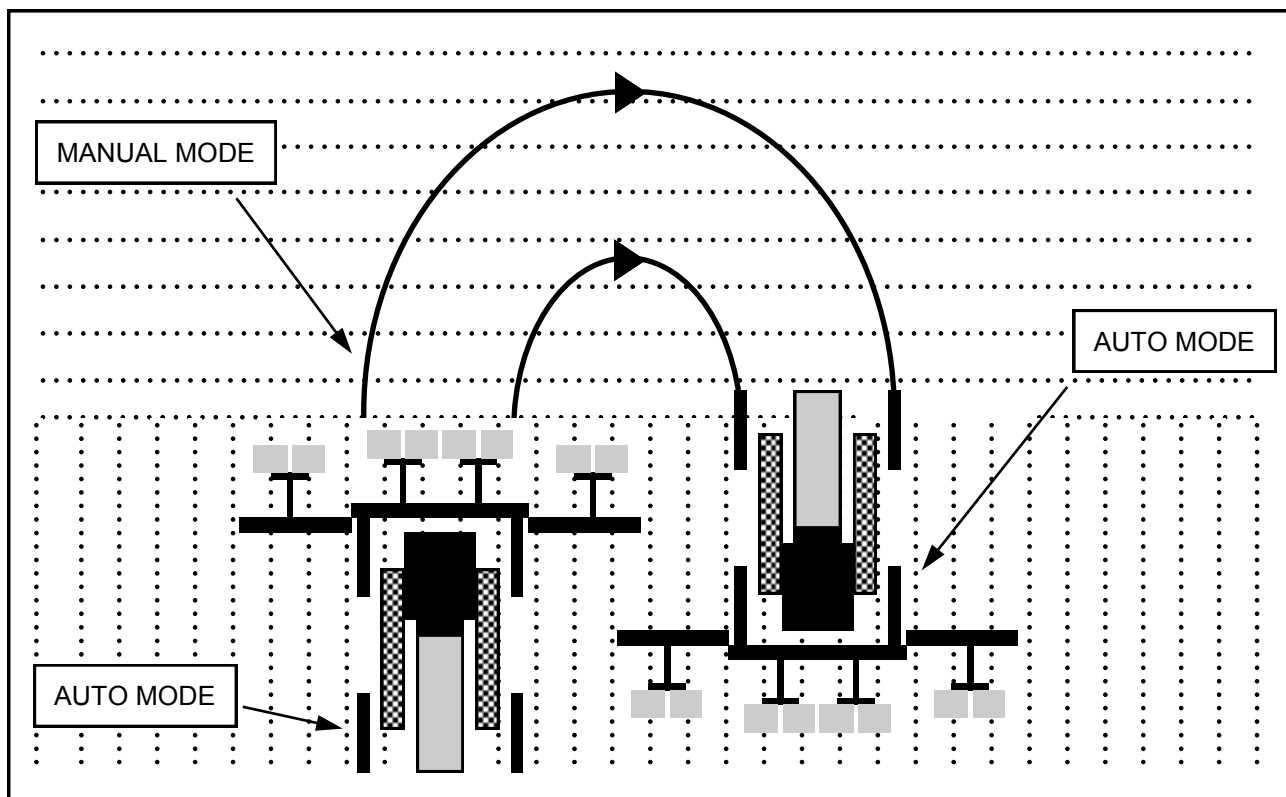

FIG 5.51

# V. OPERATING INFORMATION

## HAGIE TASSELTROL® CONTINUED



FIG 5.52

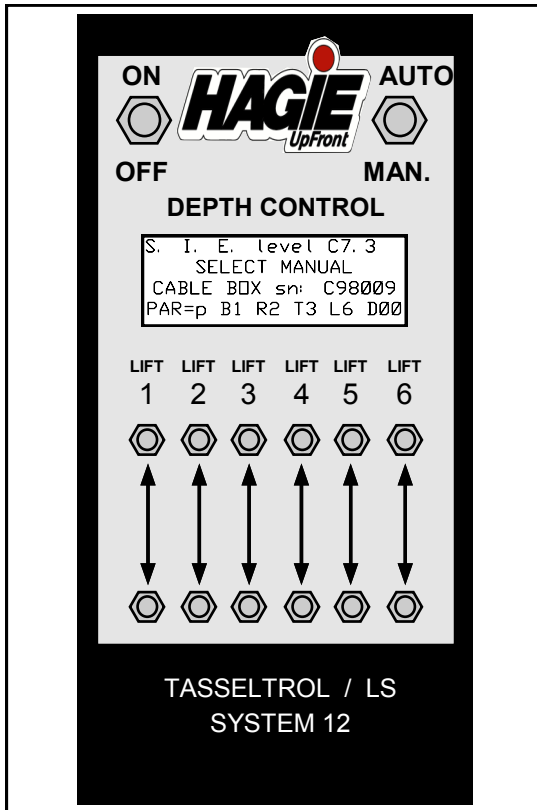

FIG 5.53

### “ALL UP” and “ALL HOLD” Function

This function can be used to raise or lower all row units at the same time. The switches to control this option are located on the hydrostat control handle (5.52). All the row units will move up when the red switch (5.52, item 1) is activated and will lower when the green switch (5.52, item 2) is activated.

The parameters for dwell on the up move can be set to 0, 5, 10, 15, 20, or 25 seconds. The heads will move up this amount of time without having to hold the red switch in (only in values greater than 0). All heads will hold this position when the parameter is reached. To resume automatic depth control, activate the green switch.

To program the **ALL- UP** and **ALL- HOLD** functions see pages 47 and 57.

### Additional Features

To temporarily lock a lift up, hold the up button for that lift while switching from the manual to auto mode. The display will show an “L” for that lift to indicate that it is locked and will not move down automatically. The lift will return back to normal operation when the manual mode is again selected. (fig. 5.54 A)

To display the supply voltage and current for the controller, press the **ALL-UP** button while in the manual mode. (fig. 5.54 B)

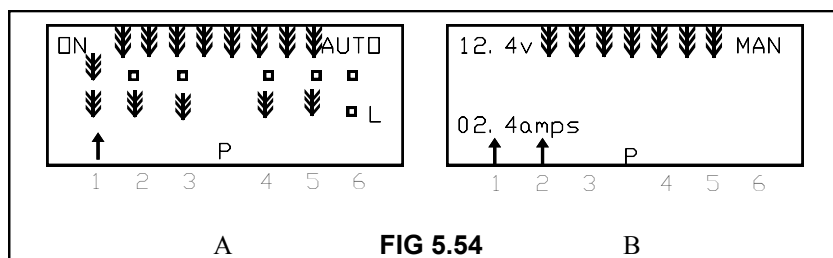

FIG 5.54

# V. OPERATING INFORMATION

## HAGIE TASSELTROL® Display Screen Quick Reference Chart

Turn on the TASSELTROL® power switch with the "AUTO/ MANUAL" switch in "AUTO" position. This is how to enter the adjusting mode. Select MANUAL to save parameters and return to AUTO for automatic head adjustments.

Turn on the TASSELTROL® power switch with the "AUTO/ MANUAL" switch in "MAN" position.

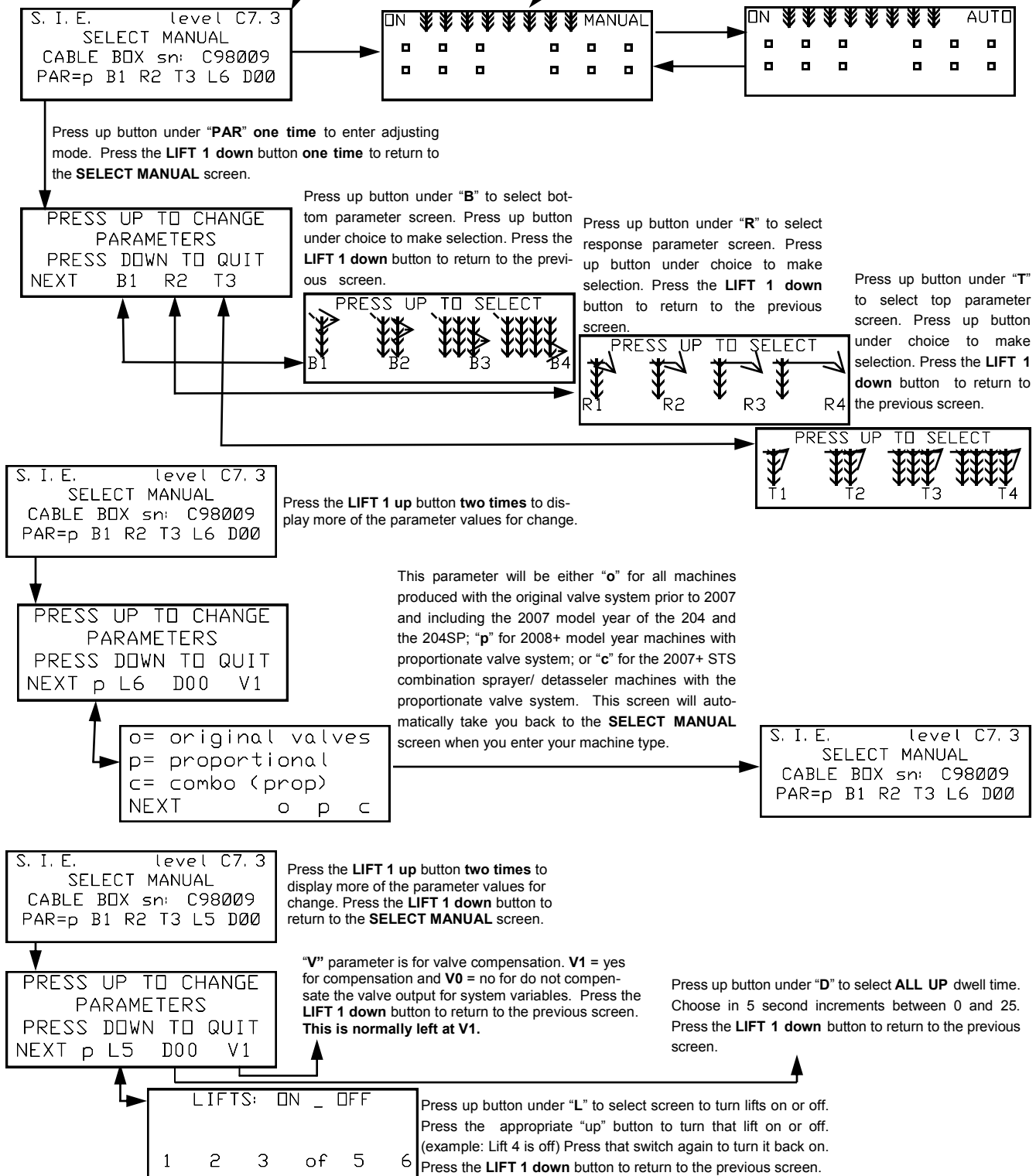

# V. OPERATING INFORMATION

## HAGIE TASSELTRÖL® DISPLAY QUICK REFERENCE CHART CONTINUED

```
S. I. E.    level C7.3
SELECT MANUAL
CABLE BOX sn: C98009
PAR=p B1 R2 T3 L6 D00
```

Press the **LIFT 1 up** button **three times** to show the current setting of the up speed for auto\*, manual and an all up move. Press the **LIFT 1 down** button to return to the **SELECT MANUAL** screen.

```
Up Speed:
                AUTO MAN ALL
<typical 05>
NEXT          05 05 05
```

```
S. I. E.    level C7.3
SELECT MANUAL
CABLE BOX sn: C98009
PAR=p B1 R2 T3 L6 D00
```

Press the **LIFT 1 up** button **four times** to show the current setting of the up offset for the first three lifts. Press the **LIFT 1 up** button to advance to the last three lifts.

```
Up Offset:
                1 2 3
<typical 00>
NEXT          +01 -06 00
```

Press the **LIFT 1 down** button to return to the **SELECT MANUAL** screen.

```
Up Offset:
                4 5 6
<typical 00>
NEXT          -07 +05 00
```

```
S. I. E.    level C7.3
SELECT MANUAL
CABLE BOX sn: C98009
PAR=p B1 R2 T3 L6 D00
```

Press the **LIFT 1 up** button **six times** to show the current setting of the down speed for auto\*, manual and an all resume move. Press the **LIFT 1 down** button to return to the **SELECT MANUAL** screen.

```
Down Speed:
                AUTO MAN ALL
<typical 05>
NEXT          05 05 05
```

```
S. I. E.    level C7.3
SELECT MANUAL
CABLE BOX sn: C98009
PAR=p B1 R2 T3 L6 D00
```

Press the **LIFT 1 up** button **seven times** to show the current setting of the down offset for the first three lifts. Press the **LIFT 1 up** button to advance to the last three lifts.

```
Down Offset:
                1 2 3
<typical 00>
NEXT          +01 -06 00
```

Press the **LIFT 1 down** button to return to the **SELECT MANUAL** screen.

```
Down Offset:
                4 5 6
<typical 00>
NEXT          -07 +05 00
```

**NOTE:** With the exception of the machine valve type screen, which automatically reverts upon changing, you may advance through all the parameter settings while making changes without returning to the **SELECT MANUAL** screen each time by pressing the **LIFT 1 up** button instead of the down button. **LIFT 1 down** saves the changes upon exiting the parameter screen.

**KEY**

- ◻ = reflector with no corn present
- ⇩ = the photo cell is blocked by corn
- ↓ = the down valve is on
- ↑ = the up valve is on

**P** = the pressure valve is on. Displayed in the lower middle part of the screen.

**LV** = the source of voltage fell below 10.8 vdc for a low voltage condition. Displayed in the upper left corner of the screen in place of "ON" when situation occurs.

**SHORT** = current exceeded 18 amps and outputs are turned off for a short time. Displayed in place of "ON" when situation occurs.

**t** = task not completed in the 30 seconds allowed, will resume on next task. Displayed in place of "ON" when situation occurs.

**of** = a lift is turned off by the parameter settings

**L** = the operator locked that lift up until manual is selected again. Displayed next to bottom photo cell icon for the valve that is locked.

**ALL HOLD** = the operator pressed the ALL-UP button on the hydrostatic handle. Displayed in the middle of the screen.

**U, D, or B** = either the up, down, or both manual buttons are pressed for that lift. Displayed next to the arrow for the lift being used.

# V. OPERATING INFORMATION

## LS PHOTOLIGHT INDICATORS

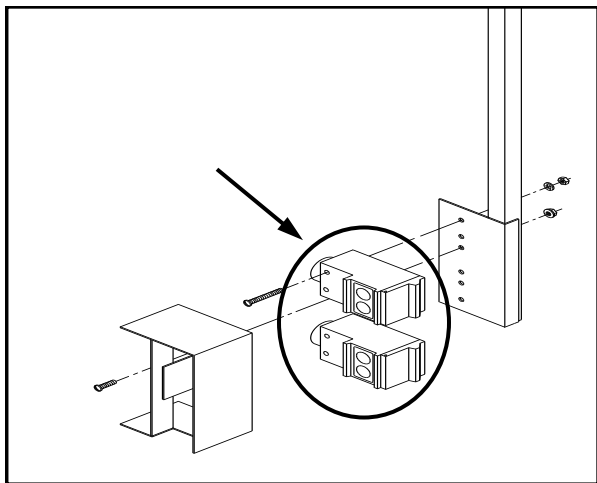

FIG 5.55



FIG 5.56

The upper and lower LS photolights (fig. 5.55) have L.E.D. lights (fig. 5.57) that indicate their operational status.

**LT/DK SWITCH** – Light/Dark switch on photolight (fig. 5.57, item 1) changes the activated condition of green L.E.D. (see below) from *ON* (“LT”) to *OFF* (“DK”). Switch does not affect the functional operation of the light, only how it is displayed. Switch should be set to “LT”.

**SENSITIVITY ADJUSTMENT SCREW** – Sensitivity adjustment screw (fig. 5.57, item 2) should always be set to maximum.

**YELLOW L.E.D.** – Yellow L.E.D. (fig. 5.57, item 3) indicates power on.

**GREEN L.E.D.** – Green L.E.D. (fig. 5.57, item 4) indicates output energized (sending a signal to Tassel-tron<sup>®</sup> box, opening the raise or lower stack valve).

**RED L.E.D.** – Red L.E.D. (fig. 5.57, item 5) indicates photolight is receiving reflected signal.

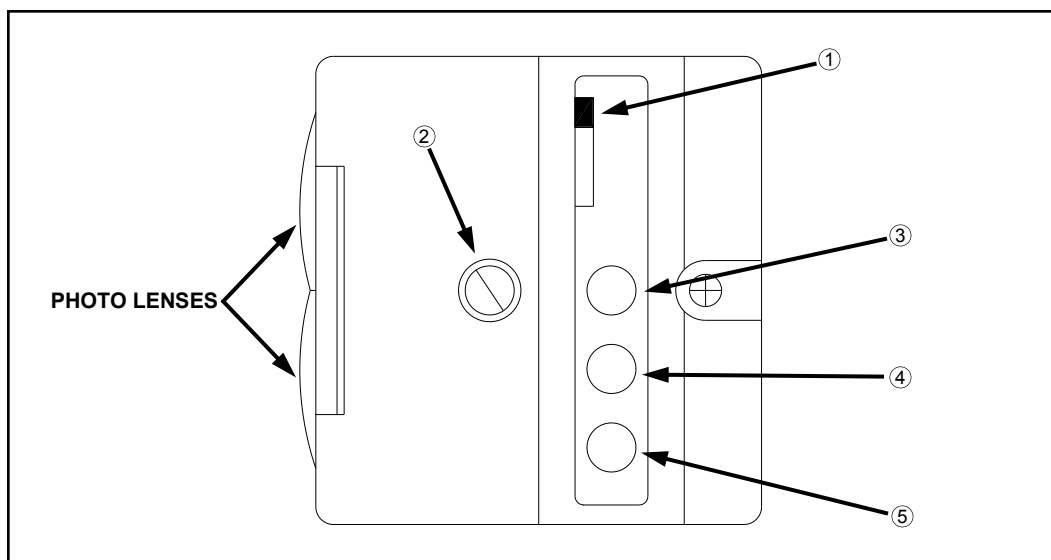

FIG 5.57

# V. OPERATING INFORMATION

## DEPTH COMMAND

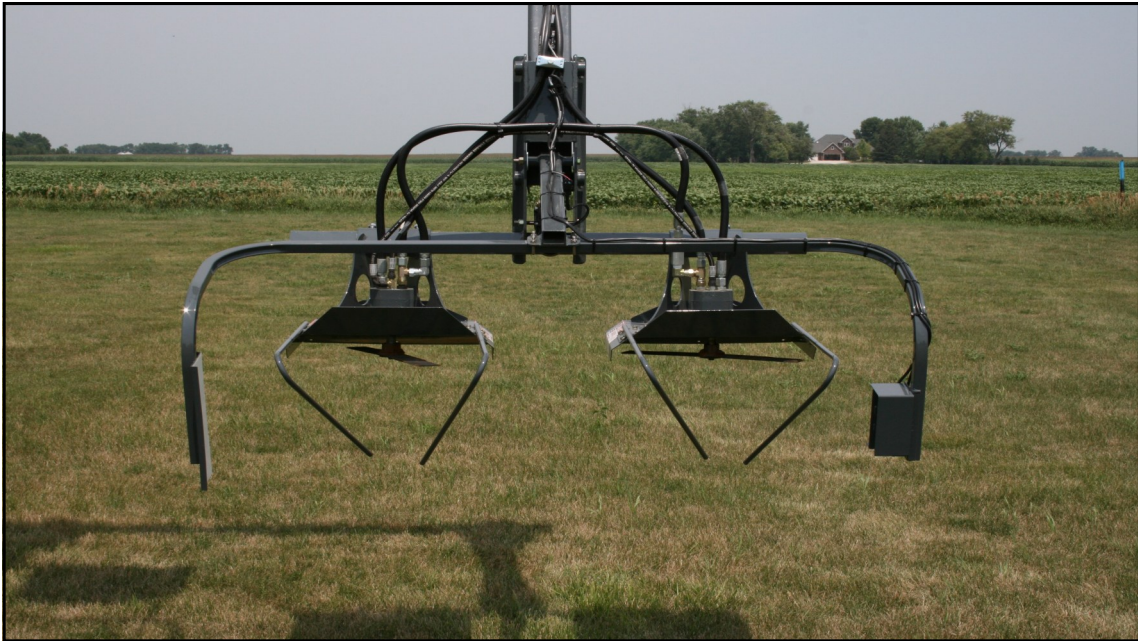

FIG 5.58

The Hagie 204SP comes available with optional adjustable DEPTH COMMAND (fig. 5.58). This allows the operator to adjust the depth of the LS system from the operator's seat. The switches are located to the right of the steering column (fig. 5.59).

To lower the cutting or pulling height, select the appropriate switch and push down. This will extend the actuator (fig. 5.60, item 1), raising the LS system, which in turn lowers the cutting or pulling height. To raise the cutting height, lower the actuator by pushing the appropriate switch up.



FIG 5.59



FIG 5.60

### NOTE:

DO NOT operate more than two actuators at one single time. This may blow the fuse located on the switch panel (fig. 5.59). For more information on the DEPTH COMMAND fuse, see page 104.

# V. OPERATING INFORMATION

## CANTRAK 2600 ENGINE MONITOR

**Fuel Gauge** - (fig. 5.62, item 1) The fuel gauge measures the amount of fuel in either fuel tank, depending on the tank selected with the fuel switch. A "YELLOW" indicator light alerts operator of low level operation.

### NOTE:

Immediately reduce engine speed and shut off ignition if any "RED" indicator lights illuminate. Determine cause and correct before continuing operation.

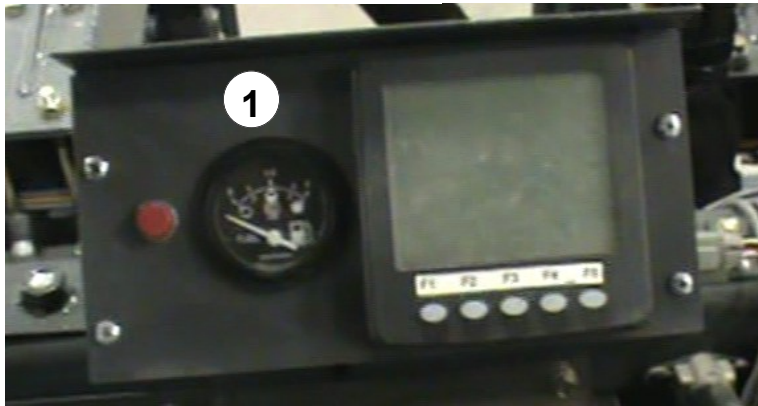

FIG 5.62

The CANtrak 2600 system is used to monitor engine parameters. It is programmed to Hagie configured settings eliminating user required set-up. The start-up screen is shown on the right.



After the initial start-up screen, you will see the quad mode display shown on the right.

Top-left quadrant: *engine speed*

Top-right: *vehicle speed*

Bottom-left: *oil pressure*

Bottom-right: *coolant temperature*

At anytime using this monitor, press F1 or F2 key to display the context dependent "button bar," like the one shown below.





# V. OPERATING INFORMATION

## CANTRAK 2600

This top-level button bar shows the basic structure of the monitor and disappears after 5 seconds of inactivity.

Press F1 to view the Tri-mode display shown in the next box below

Press F2 to view the Quad-mode shown above

Press F3 to view the Uni-mode shown below

Press F4 to view the Active Alarm mode shown below

Press F5 to view the Contrast mode or hold for 3 seconds to view Configuration Menu show below

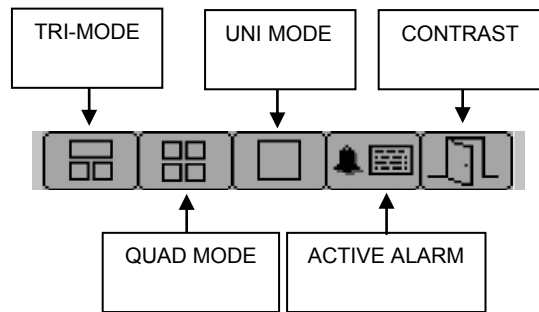

The Tri-mode display is shown on the right:

Top: *total engine hours*

Bottom-left: *fuel rate*

Bottom-right: *systems voltage*

Press F2 to go back to quad mode display or F3 to see the Uni display mode on the next page.

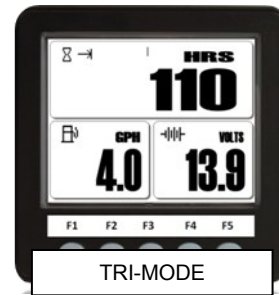

The Uni display mode plots the data history in an X-Y graph format. Please refer to *page 12* of the manual for further info.

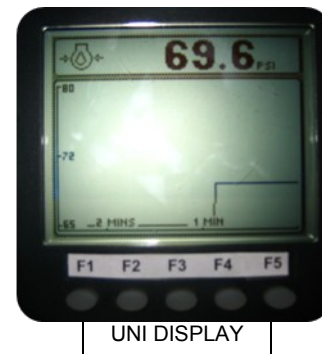

The Active Alarm display mode lists all active/current alarms received by the unit. Please refer to *page 18* of the manual for further info.

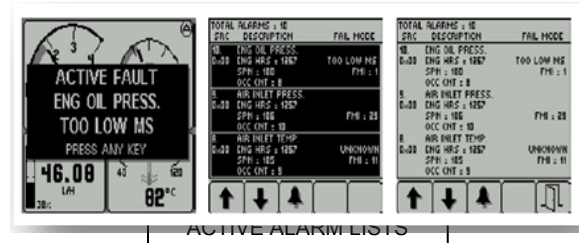

# V. OPERATING INFORMATION

---

## CANTRAK 2600

The Configuration Menu is shown on the right. For further information regarding configuration settings refer to *page 20* of the manual.



**Refer to Cantrak user manual for further use and programming.**

# V. OPERATING INFORMATION

## STANDARD OPERATOR SEAT

- 1- **Fore-Aft Adjustment.** Pull the fore-aft lock lever to the left to unlock and adjust seat forward or rearward to desired position. Release lock lever to lock fore-aft position.
- 2- **Ride Height.** To adjust seat height, place all your body weight on the seat and locate the height adjustment dial. Rotate the dial clockwise to lower seat height and counter-clockwise to raise seat height.
- 3- **Ride Firmness.** To adjust ride firmness adjust the ride dial on the left of the seat clockwise to “soften” the ride and counter-clockwise to “stiffen” the ride.
- 4- Oper server



FIG 5.55

The operator presence switch (OPS) is located in the seat. The switch protects the operator from exposure to moving parts or hazards in regards to the detasseler cutting blades or quad pullers by introducing an electrical interlock that ensures that when the operator is out of the cab the operation of these functions is stopped.

This is achieved by using the seat switch to prevent the detasseler and spray systems from operating machine actuators if the operator is not seated for 3 seconds

# V. OPERATING INFORMATION



FIG 5.67

## FUEL TANK SELECTOR

To draw engine fuel from the right fuel tank, set the fuel selector switch (fig. 5.69) to the “RIGHT” position. To switch to the left tank, set the fuel selector switch to the “LEFT” position. You may operate from either tank until the “YELLOW” low level indicator light illuminates. Then you must either switch to the other tank or refuel.



FIG 5.68

## STEERING COLUMN

To adjust the Hagie 204SP’s steering column for driver comfort or to ease cab exit and entry, locate the tilt lock lever in the center of the column (fig. 5.67). Push down on the lever to release the lock. Pull or push the column to the desired position and release the lever to re-lock the steering column.(fig. 5.68)



FIG 5.69

# V. OPERATING INFORMATION

## LIGHTS



FIG 5.70

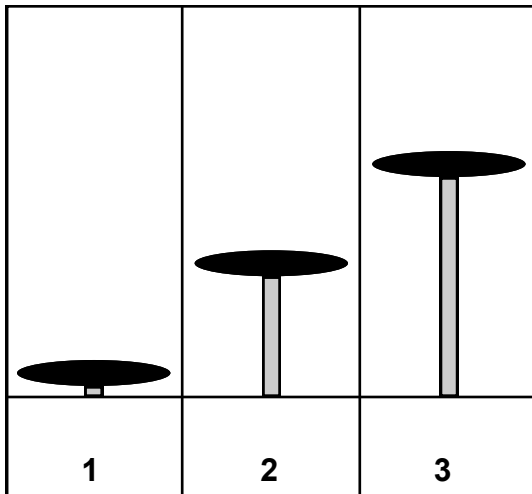

FIG 5.71



FIG 5.72 ↑

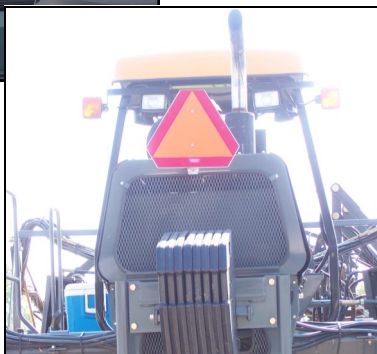

FIG 5.73 ↓



FIG 5.74

FIG 5.75



**WORK LIGHTS** – The front of the canopy or optional cab houses four halogen work lamps (fig. 5.74 and fig. 5.75) and the rear houses two halogen work lamps (fig. 5.72 and fig. 5.73). Locate the light switch on the console panel (fig. 5.70). Pulling the switch out to the first “ON” position (fig. 5.71 item 2) will activate all available lights. Pulling the switch out to the second “ON” position (fig. 5.71 item 3) will deactivate the two outer front lights in addition to the two rear work lights.

The ignition key does not have to be on in order to operate any of the work lights, but extended use without the engine operating to charge the battery is not recommended.

# V. OPERATING INFORMATION

## LIGHTS CONTINUED

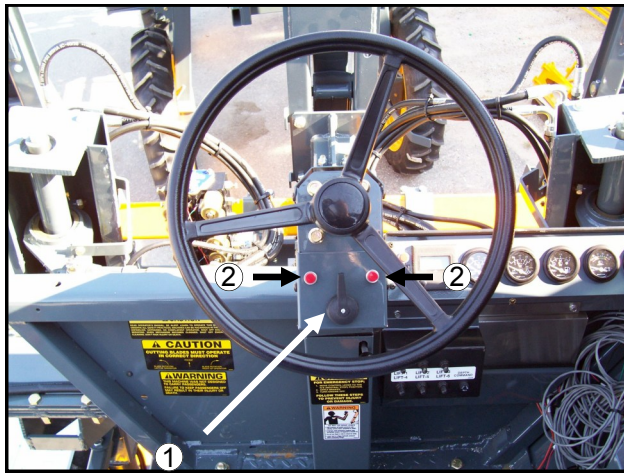

FIG 5.76

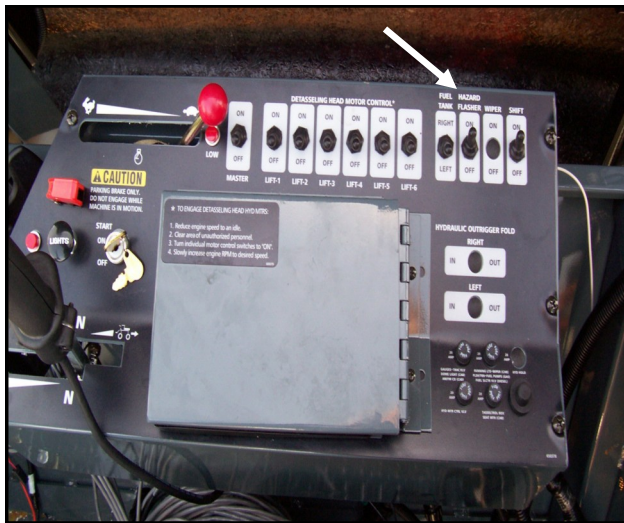

FIG 5.77

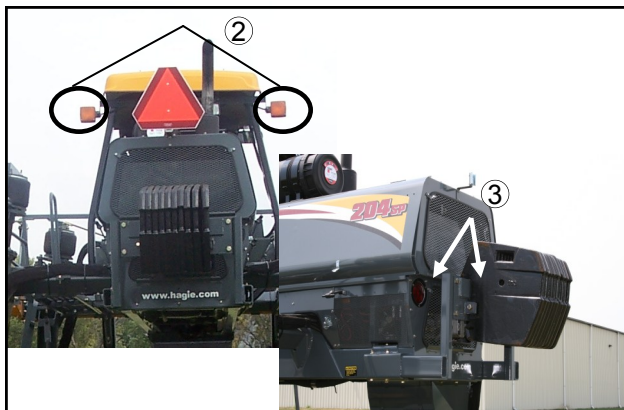

FIG 5.78

### Turn Signals

To activate the front (fig. 5.78, item 1 or 2) and rear turning signals (fig. 5.78, item 3) move the turn signal lever (fig. 5.76, item 1) right during a right-hand turn and left during a left-hand turn. Steering column-mounted turn signal indicators (fig. 5.76, item 2) will correspondingly flash when either side of the turn signals is activated. The turn signal lever is not a self-centering switch; you must return it to the “OFF” position by hand after completing your turn.

### Hazard/Warning Lights

To activate the flashing hazard/warning lights (fig. 5.78, item 1 or 2) flip the “FLASHER” switch to the “ON” position (fig. 5.77). Activate the hazard/warning lights anytime traveling on a public road, day or night, unless prohibited by law.

### Running Lights

Activating any of the work lights will also turn on the “RED” running lights on the rear of the machine (fig. 5.78, item 3).

# V. OPERATING INFORMATION

---

## HAGIE 204SP CAB



FIG 5.79

Emergency Exit.....	69
Climate Controls .....	70
Air Suspended Seat.....	71
Radio.....	72
Windshield Wiper.....	72
Interior Lighting .....	72

# V. OPERATING INFORMATION

## CAB OPERATION CONTINUED



FIG 5.80

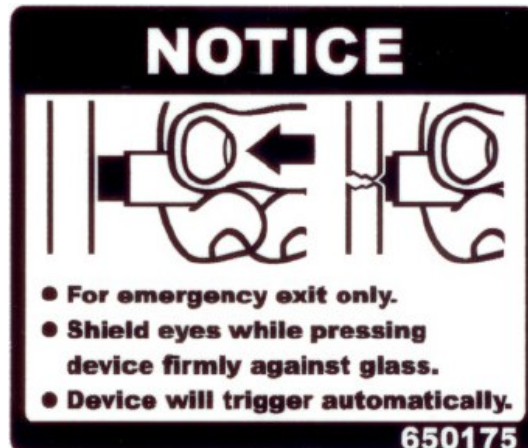

### Emergency Exit

Any glass in the cab is able to be shattered using the Res-Q-Me tool that hangs on the left hand side of the cab (fig. 5.80).

To use the tool, firmly press it against any glass. The tool will trigger a sharp point to shatter the glass. Be careful not to get any broken glass into your eyes! Carefully push away any remaining glass and exit the cab.

### E-Stop

The emergency stop is attached to the operator's station frame in front of the side console.

The emergency stop switch provides a quick and positive method for stopping the engine in an emergency situation. When the button is depressed, it locks in position and removes the ignition signal to shutdown the engine. To reset the switch, turn the button in the direction of the arrows on the face of the button.

Do not use this button for non-emergency stopping or as a parking brake.





# V. OPERATING INFORMATION

## CAB OPERATION CONTINUED

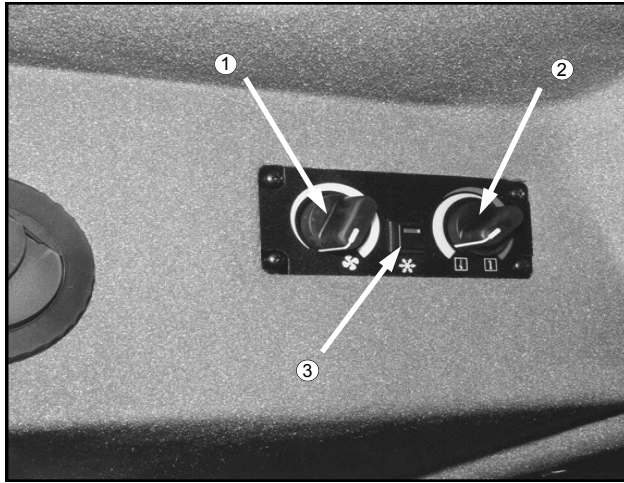

FIG 5.83



FIG 5.84

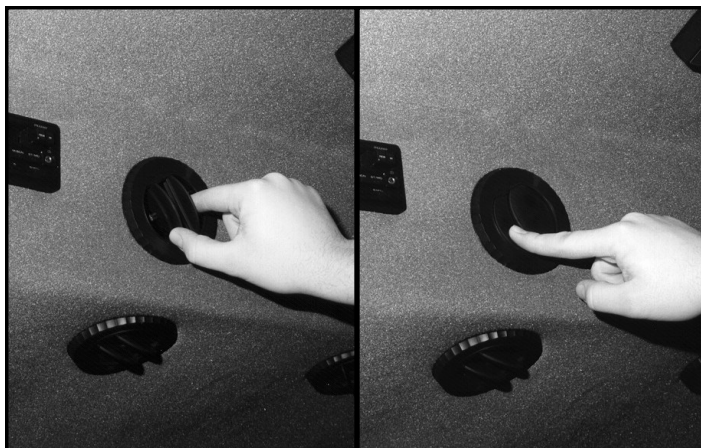

FIG 5.85

## Climate Controls

**ADJUSTING FAN BLOWER SPEED-** Fan blower speed is controlled by the left rotary dial on the cab climate control panel (fig. 5.83, item 1). The fan blower speed is a continuously variable adjustment. To increase fan speed, rotate fan blower dial clockwise. To reduce fan speed, rotate fan blower dial counterclockwise. To shut fan blower off, rotate fan blower dial all the way counterclockwise.

**ADJUSTING TEMPERATURE SETTING -** Forced air temperature adjustments are controlled by the right rotary dial on the cab climate control panel (fig. 5.83, item 2). Temperature control is a continuously variable adjustment. To increase forced air temperature, rotate temperature dial clockwise. To decrease forced air temperature, rotate temperature dial counterclockwise.

**OPERATING AIR CONDITIONING -** To activate the air conditioner, depress the air conditioning switch (fig. 5.83, item 3). Adjust fan speed and temperature accordingly.

**ADJUSTING VENTS -** Air vents may be adjusted by rotating them for desired direction (fig. 5.84) or individually turned on or off with the directional fins (fig. 5.85).

**SERVICING A/C SYSTEM -** See pages 86 and 90 for service information.

# V. OPERATING INFORMATION

## CAB OPERATION CONTINUED

### AIR SUSPENDED CAB SEAT

- 1- **Ride Firmness.** Pull knob out to release air and “soften” ride. Push knob in to pump air and “stiffen” ride. (Ignition key must be in the “ON” position in order to activate the seat pump.)
- 2- **Fore-Aft Adjustment.** Release fore-aft lock by pulling lever out. Slide forward or back to desired position. Release lever to lock.
- 3- **Height Adjustment.** Release height lock by pulling lever up. Apply body weight slowly to lower seat position or remove body weight slowly to raise seat position. When at desired height release lever to lock.
- 4- **Back Angle Adjustment.** Rotate knob counter-clockwise to tilt back rest forward and clockwise to tilt back rest back.
- 5- **Arm Rest Adjustment.** Unzip either arm rest to expose the arm rest adjustment bolt. Turn bolt in to raise arm rest tilt and out to lower arm rest tilt (fig. 5.86, item 6).



FIG 5.86

# V. OPERATING INFORMATION

## CAB OPERATION CONTINUED

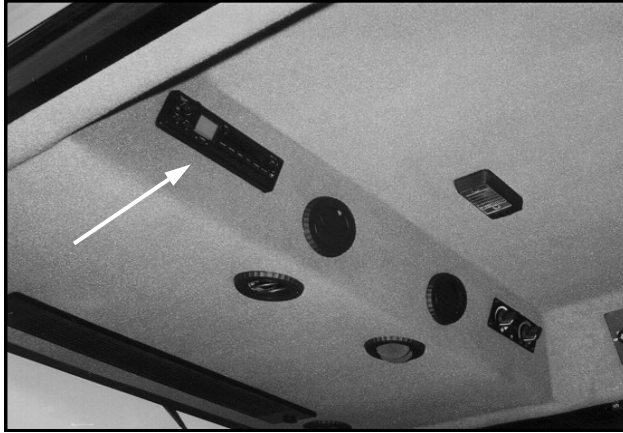

FIG 5.87

### Radio

Your Hagie 204SP is equipped with an AM/FM/Weather Band tuner (fig. 5.87) and two speaker system.



FIG 5.88

### Windshield Wiper

To turn the windshield wiper on, locate the windshield switch toward the rear of the console panel (fig. 5.88). Flip the switch to the “ON” position. The wiper will continue to operate until the switch is returned to the “OFF” position.

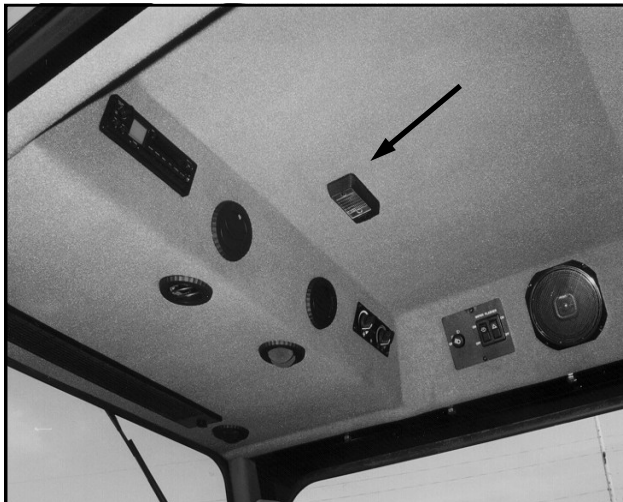

FIG 5.89

### Interior Lighting

Interior lighting is provided by a ceiling mounted dome light (fig. 5.89). The ignition key must be in the “ON” position for the interior light to operate.

# VI. TRANSPORTING

---

## DRIVING

When driving the detasseler on a public road or highway, drive carefully and follow these steps:



**FIG 6.1**

1. Always have the outrigger in the folded position and locked when driving or transporting.
2. Flashing hazard/warning lights have been placed on the detasseler to warn other drivers.
3. A SMV (Slow Moving Vehicle) emblem has been mounted on the detasseler to warn other drivers that one is moving slowly. Keep it properly displayed, unless prohibited by law.
4. Know and obey all state laws for driving farm equipment on a public road or highway.
5. Adjust the detasseler's speed to suit the conditions.
6. Slow down and use turn signals before turning.
7. Pull over to side of road before stopping.
8. Keep a proper lookout, and maintain control of the detasseler.
9. Do not drive under trees, bridges, wires, or other obstructions unless there is clearance.
10. Use extra care before entering or leaving a public road or highway.
11. Raise light beacon on top of cab and turn on.



# VI. TRANSPORTING

## OUTRIGGER FOLD OPTION

### MANUAL (STANDARD)



FIG 6.2

The manual fold option is a ratchet system connected to the outrigger and the center toolbar (fig. 6.2). The ratchet should not be used in place of the lock bar during transporting.

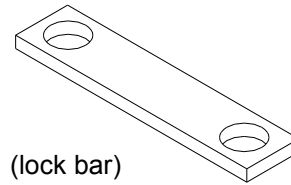

### HYDRAULIC (OPTIONAL)

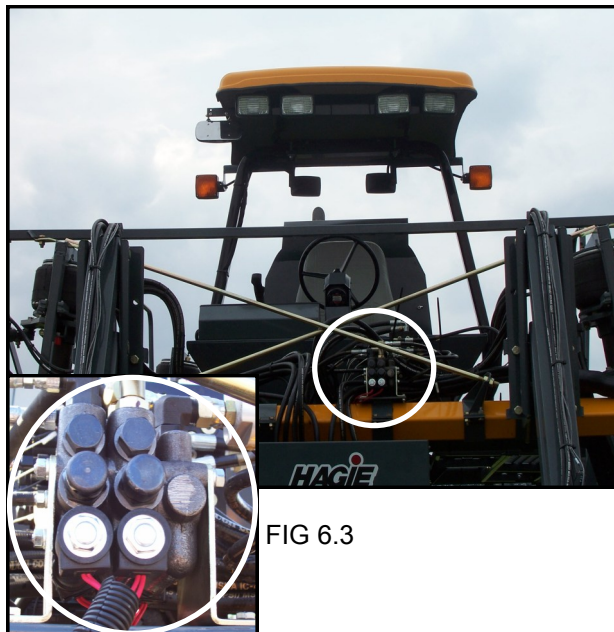

FIG 6.3

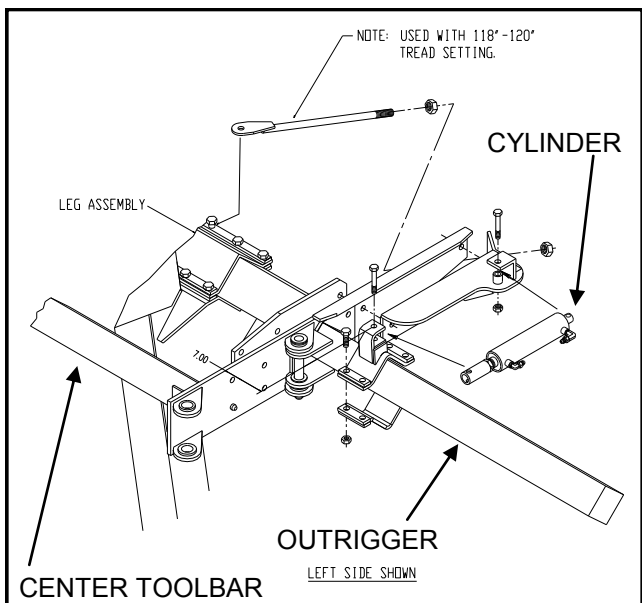

FIG 6.5

The hydraulic fold option is controlled by a valve mounted on the center toolbar (fig. 6.3), and a cylinder attached to the outrigger and center toolbar (fig. 6.5).

The valve is activated using either the left or right switches located on the console above the fuses (fig. 6.4).



FIG 6.4

# VI. TRANSPORTING

---

## TRAILERING

### LOADING:

When moving the detasseler onto a trailer, follow these steps completely:

1. Pull the trailer to flat ground. Apply the pulling vehicle's parking brake and turn off the engine.  
Use tire chocks to keep the trailer from moving.
2. Fold in the detasseler's outriggers and lock them to the detasseler.
3. Lower the trailer ramps and set the ramp spacing for the detasseler's tread setting.
4. Get someone to help guide you onto the trailer. Keep everyone at a safe distance from the detasseler.
5. Allow enough room between the detasseler and the pulling vehicle for turning.
6. Secure the detasseler to the trailer. See the trailer's owner and operator manual for instructions.
7. Cover or remove the SMV (Slow Moving Vehicle) emblem when traveling over 25 miles per hour.

#### NOTE:

The loaded height and width of the trailer must conform to the law of the state in which it is being used.



Stopping the detasseler on the trailer loading ramps may result in detasseler tip-over.

### UNLOADING:

When moving the detasseler off of a trailer, follow these steps completely:

1. Pull the trailer to flat ground. Apply the pulling vehicle's parking brake and turn off the engine.  
Use tire chocks to keep the trailer from moving.
2. Lower the trailer ramps and set ramp spacing for the detasseler's tread setting.
3. Release securing restraints carefully.
4. Get someone to help guide off the trailer. Keep everyone a safe distance from the detasseler.
5. Uncover or replace the SMV (Slow Moving Vehicle) emblem.

# VI. TRANSPORTING

## TRAILERING CONTINUED

**NOTE:**

Be sure to read and understand the trailer's owner and operator manual. Hitch the trailer to the pulling vehicle as shown in the trailer's owner and operator manual.

**NOTE:**

Extra care should be taken when loading the detasseler onto any trailer. Consider whether it is best to back the detasseler on or drive the detasseler forward.

## TOWING

**NOTE:**

It is not recommended that the detasseler be towed, but if it should ever be necessary, follow these steps carefully:

1. Fold the outriggers in and lock them to the detasseler.
2. Disengage Torque Hubs® by removing the two outer cap bolts, reversing the cap, and replacing the bolts. This process pushes on a spring-loaded splined shaft, disengaging the Torque Hub®. Failure to do this may damage the hub or brakes.

(fig.6.7)

**NOTE:**

Wheel motors will be damaged if these steps are not taken.



**FIG 6.7**



## CAUTION

When re-engaging Torque Hubs®, make sure the spring loaded splined shaft has returned to its expended position.

# VI. TRANSPORTING

## TOWING CONTINUED

### NOTE:

In order for the power steering system to function, the detasseler's engine must be running.

3. Turn on the flashing hazard/warning lights.
4. When towing, it is necessary that two vehicles of sufficient size and weight for adequate pulling and braking are used. One of these vehicles is used for pulling the detasseler; the second vehicle for braking if the detasseler starts to overtake the towing vehicle, such as going downhill. The reason for this is the detasseler, once the Torque Hubs<sup>®</sup> have been disengaged, has no braking power of its own. Use extreme caution.



## WARNING

**Secure items (tow straps, chains, etc.) between towing vehicle, braking vehicle, and detasseler to ensure that they will not dislodge.**

5. If necessary, relocate the SMV emblem so that it is visible from the rear.
6. Always reduce towing speed well in advance of any anticipated turns.
7. Know and obey the state laws for towing farm equipment on public roads and highways.

### NOTE:

Excessive speed may cause damage to the Torque Hubs<sup>®</sup> as well as the hydrostatic system. Do not exceed 25 MPH when towing detasseler.

### NOTICE:

- The safest way to transport your detasseler is to drive it
- Please use extreme caution when attempting to transport in any other way.
- Remember that you are not the only thing on the roadways— be cautious of other drivers and courteous.



## VII. SERVICE AND MAINTENANCE

PAGE NO	Service Point	CLEAN	CHANGE	CHECK	GREASE	DRAIN
82	ENGINE OIL		I	DAILY		
84	RADIATOR COOLANT LEVEL			DAILY		
85	COOLANT OVERFLOW RESERVOIR LEVEL			DAILY		A
84	COOLANT CONCENTRATION		AS REQ	500 HRS*		
87	RADIATOR GRILLE SCREENS	AS REQ				
99	ENGINE DRIVE BELT		AS REQ	DAILY		
99	A/C COMPRESSOR BELT (CAB ONLY)		AS REQ	250 HRS		
86	A/C COMPRESSOR (CAB ONLY)		B			
90	A/C DRYER (CAB ONLY)		AS REQ			
91	PRIMARY FUEL FILTER (WATER SEPERATOR)		500 HRS*			DAILY
91	SECONDARY FUEL FILTER		500 HRS*			
91	IN-LINE FUEL FILTERS		AS REQ			
88	AIR INTAKE FILTER	**	C			
88	FILTER MINDER®		D	DAILY		
82	HYDRAULIC RESERVIOR OIL LEVEL		500HRS*	DAILY		
89	HYDRAULIC SUCTION FILTER		E*			
89	HYDROSTATIC CHARGE PRESSURE FILTER		E*			
89	HYDRAULIC RETURN FILTER		E*			
90	HIGH PRESSURE IN-LINE FILTER (LIFT VLV/DUMP VLV)	AS REQ				
83	TORQUE HUB® OIL LEVEL		F	DAILY		
93	TORQUE HUB® ZERK (4 PLACES- 1 EA. LEG) (SEAL BOOT)				H	
28	QUAD PULLER PSI (4 PLACES EACH ROW)			DAILY		
94	QUAD PULLER BEARINGS (4 PLACES EACH ROW)				2X DAILY	
30	CUTTER BLADE RETAINING BOLT (TIGHTEN)			DAILY		
93	LEG BEARING ZERKS (12- 3 EA LEG)				2X DAILY	
102	LEG MOUNT BOLT TORQUE			DAILY		
95	BATTERY	100 HRS	AS REQ	DAILY		
101	LUG NUT TORQUE			G		
103	TIRE PRESSURE			50 HRS		
92	FRESH AIR CAB FILTER (CAB ONLY)	AS REQ	500 HRS*			
92	CHARCOAL CAB FILTER (CAB ONLY)		AS REQ			
92	RECIRCULATION FILTER (CAB ONLY)	AS REQ	AS REQ			
96-98	FUSES/CIRCUIT BREAKERS		AS REQ			
105	AIR RIDE SUSPENSION (VISUAL)			DAILY		
105	AIR RIDE SUSPENSION (TAPE MEASURE)			DAILY		

\*OR AT THE BEGINNING OF THE SEASON (YEARLY), WHICHEVER COMES FIRST, OR AS REQUIRED

\*\*NOT RECOMMENDED

NOTE A: COOLANT SYSTEM SHOULD BE DRAINED EVERY OTHER SEASON OR EVERY 1000 HRS.

NOTE B: CHARGE AS REQ; USE PROPER EQUIPMENT

NOTE C: FOLLOW FILTER MINDER READINGS

NOTE D: RESET EACH TIME YOU SERVICE AIR FILTER

NOTE E: 1ST 50 HRS, THEN 250 HRS THEREAFTER

NOTE F: 1ST 50 HRS, THEN 100 HRS THEREAFTER

NOTE G: IMMEDIATELY, THEN 50 HRS THEREAFTER

NOTE H: GREASE EVERY 50 HRS. OR AS NEEDED, WIPE EXCESS GREASE AWAY AFTER SERVICING

NOTE I: SEE ENGINE MANUFACTURER'S MANUAL

# VII. SERVICE AND MAINTENANCE

## SERVICE INTERVALS

### Initial checks after receiving machine

**IMMEDIATELY**  then 

- 1) Check lug nut torque, then every 50 hours (page 101)

**FIRST 50 HOURS**  then  or 

- 1) Change Torque Hub<sup>®</sup> oil, then every 100 hours (page 83)
- 2) Change hydrostatic charge pressure filter, then every 250 hours (page 89)
- 3) Change hydraulic suction filter, then every 250 hours (page 89)
- 4) Change hydraulic return filter, then every 250 hours (page 89)

**Daily** 

- 1) Check engine oil (page 82)
- 2) Drain primary fuel filter (water separator) (page 91)
- 3) Check radiator coolant level (page 84)
- 4) Check radiator coolant overflow reservoir level (page 85)
- 5) Check engine drive belt (pages 99)
- 6) Check Filter Minder<sup>®</sup> (page 88)
- 7) Check hydraulic oil reservoir level (page 82)
- 8) Grease all leg bearings (page 93)
- 9) Check leg mount bolts (page 102)
- 10) Check battery (page 95)
- 11) Check quad puller PSI (page 28)
- 12) Grease quad puller bearings (2X) (page 94)
- 13) Check and tighten cutter blade retaining bolt (page 30)
- 14) Visually check air bag suspension height (page 105)

# VII. SERVICE AND MAINTENANCE

---

## SERVICE INTERVALS CONTINUED

As Required



- 1) Change coolant concentration (page 84)
- 2) Clean radiator grille screens (page 87)
- 3) Change engine drive belt (page 99)
- 4) Change A/C compressor belt (page 99)
- 5) Change A/C dryer (page 90)
- 6) Charge A/C compressor (page 86)
- 7) Change primary fuel filter (water separator) (page 91)
- 8) Change secondary fuel filter (page 91)
- 9) Change in-line fuel pre-filter (page 91)
- 10) Change hydraulic reservoir oil (page 82)
- 11) Clean high-pressure in-line filter on lift assembly dump valve (page 90)
- 12) Change battery (page 95)
- 13) Clean fresh air intake cab filter (page 92)
- 14) Change fresh air intake cab filter (page 92)
- 15) Change charcoal cab filter (page 92)
- 16) Clean recirculation cab filter (page 92)
- 17) Replace fuses and circuit breakers (pages 96-98)
- 18) Grease Torque Hub<sup>®</sup> seal boot (page 93)
- 19) Adjust air-ride suspension height (page 105)
- 20) Change engine air filter element per Filter Minder<sup>®</sup> readings (page 83)



# VII. SERVICE AND MAINTENANCE

## SERVICE INTERVALS CONTINUED

### Every 50 HOURS

- 1) Check tire pressure (page 103)
- 2) Check lug nut torque (page 101)
- 3) Measure air bag suspension height with tape measure (page 105)
- 4) Grease Torque Hub® seal boot (page 93)

### Every 100 HOURS

- 1) Check Torque Hub® oil level (page 82)
- 2) Clean battery (page 95)

### Every 250 HOURS

- 1) Check A/C compressor belt (page 99)
- 2) Change hydrostatic charge pressure filter (page 89)
- 3) Change hydraulic suction filter (page 89)
- 4) Change hydraulic return filter (page 89)

### Every 500 HOURS or

- 1) Check coolant concentration (page 84)
- 2) Change primary fuel filter (water separator) (page 91)
- 3) Change secondary fuel filter (page 91)
- 4) Change hydraulic reservoir oil (page 82)
- 5) Change Torque Hub® oil (page 83)
- 6) Pack bearing on non-drive tire hub in quad puller assembly (page 94)
- 7) Change engine oil (page 82)

### Every 1000 HOURS

- 1) Drain coolant system (84-85)

# VII. SERVICE AND MAINTENANCE

---

## FLUIDS

### Engine oil

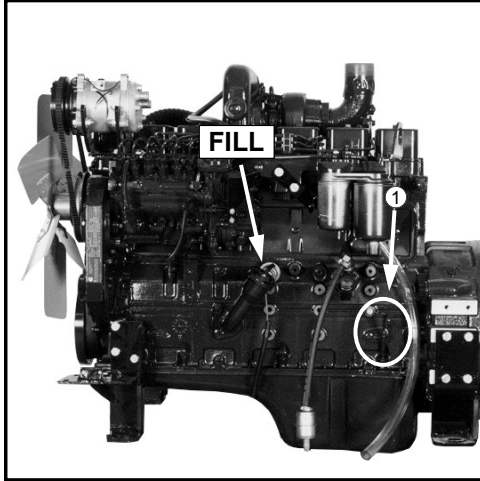

FIG 7.1

**OIL LEVEL** - The engine oil level dipstick is located on the left-hand side of the diesel engine (fig. 7.1, item 1). Never operate the engine with the oil level below the “L” (low) mark or above the “H” (high) mark. Wait at least five minutes after shutting off the engine to check the oil level; this allows time for the oil to drain to the oil pan. Check the engine oil level daily, change it yearly or every 500 hours.

**CAPACITY** - Low to high mark capacity is 2.0 quarts. Engine oil pan capacity (including filter) is 15.9 quarts (SAE 15W 40).

#### NOTE:

The engine must be level when checking the oil level to make sure the measurement is correct.

### Hydraulic Oil Reservoir

**OIL LEVEL** - Check the hydraulic oil level in the reservoir using the dipstick daily (fig. 7.2). Add just enough fluid so the level reaches the bottom tip of the dipstick. Hydraulic oil will expand when heated in a system, and measuring the reservoir by these levels allows for expansion. Always check the hydraulic oil level when it is cool and with lift cylinders in lowered position.

**TYPE** - Premium hydraulic fluids containing high quality rust/oxidation/and foam inhibitors are required. Hydraulic oil must conform to one of the following types: anti-wear hydraulic oil, type F automatic transmission fluid, or agricultural hydraulic transmission fluid. Replace the oil in the hydraulic reservoir at 500 hours or at the beginning of each detasseling season, whichever comes first.



FIG 7.2

# VII. SERVICE AND MAINTENANCE

## FLUIDS CONTINUED

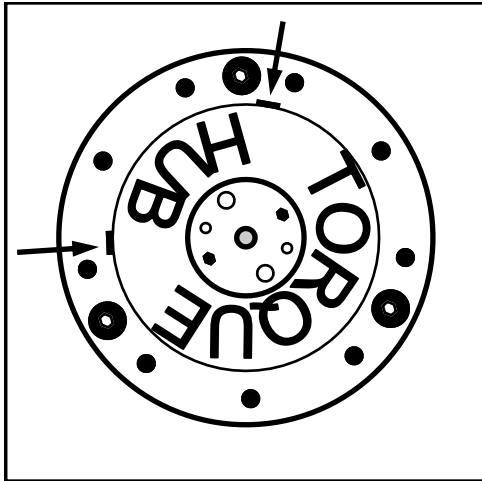

FIG 7.3



FIG 7.4



FIG 7.5

### Torque Hub<sup>®</sup> Oil

**OIL LEVEL** - Each Torque Hub<sup>®</sup> should maintain an oil level of half full at all times. Less than that would limit lubrication, and over half full could cause overheating and damage. To check oil level, position Torque Hub<sup>®</sup> so one of the drain plugs is positioned at 12 O'clock (fig. 7.3). The other plug will be either at 9 O'clock or 3 O'clock. Remove the lower plug: if no oil comes out, oil level is too low. Check Torque Hub<sup>®</sup> oil level daily.

If EP-90 oil is needed, remove the top plug and fill until it just starts to come out the lower hole (fig. 7.4). With the oil at a satisfactory level, re-install plugs.

**CHANGE** - The Torque Hub<sup>®</sup> oil should be changed after the first 50 hours of operation. Subsequently, it should be changed every 100 hours after that, or once a year whichever comes first.

To change the Torque Hub<sup>®</sup> oil, position one of the plugs at 6 O'clock, and the other at either 3 O'clock or 9 O'clock. Remove the bottom plug to drain the oil. Once all of the oil is drained, re-install the bottom plug and remove the top plug. Refill Torque Hub<sup>®</sup> with EP-90 or 85-140 oil as described above.

**GENERAL MAINTENANCE** - If your detasseler is going to sit for an extended period of time, occasionally rotate the hubs by driving the detasseler forward or backward a few feet to adequately coat all internal hub parts (fig. 7.5). This will prevent rusting if moisture inadvertently entered the hub during an oil change. Failure to rotate hub and disperse oil may cause rusting and internal damage.

# VII. SERVICE AND MAINTENANCE

## FLUIDS CONTINUED

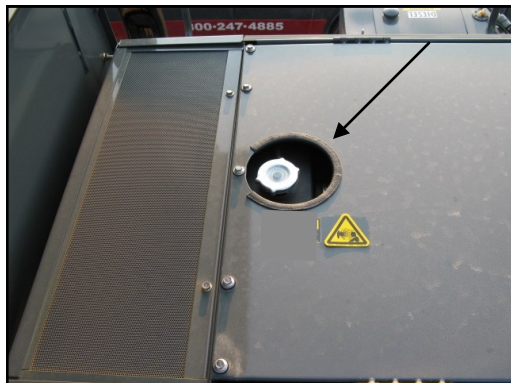

FIG 7.6



FIG 7.7

Ethylene Glycol		
40%	-23°C	-10°F
50%	-37°C	-34°F
60%	-54°C	-65°F

FIG 7.8

## Cooling System

**COOLANT TYPE** - Your cooling system should always be sufficiently charged with an adequate mixture of antifreeze and water, regardless of the climate, in order to maintain a broad operating temperature range. Your cooling system has been factory-charged with an ethylene glycol-based antifreeze.

**NOTE:**

Ethylene glycol-based antifreeze and propylene glycol-based antifreeze should never be mixed.

**CHECKING CONCENTRATION** - The radiator cap is located immediately behind the rear of the operator's station (fig. 7.6). Never remove a cap from a hot engine. Always allow the engine to cool before servicing cooling system.

A 50/50 antifreeze/water mixture is a conservative mixture which allows good protection against both overheating and freezing. The table in figure 7.8 gives a few examples of ethylene glycol antifreeze/water mixture protection values.

Concentration should be checked every 500 hours or at the beginning of each winter, whichever comes first. It should be checked using a refractometer; "floating ball"-type density testers or hydrometers are not accurate enough for use with heavy duty diesel cooling systems.

**CHECKING FLUID LEVEL** - The coolant level should be checked daily while the engine is cold. This should be done at the same time that the overflow is checked. If you do not see fluid in the neck of the radiator then fluid must be added. Be sure that if you are adding anti-freeze that it is ethylene glycol-based. DO NOT mix with propylene glycol-based antifreeze.

# VII. SERVICE AND MAINTENANCE

## FLUIDS CONTINUED

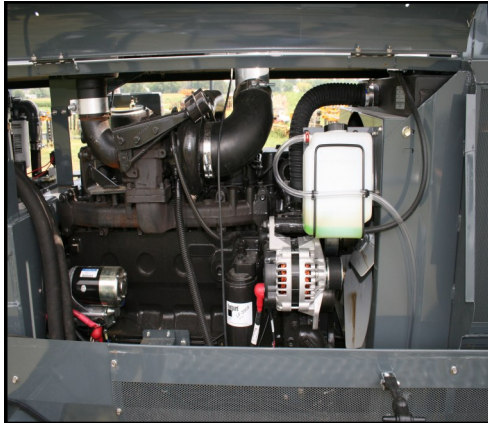

FIG 7.9

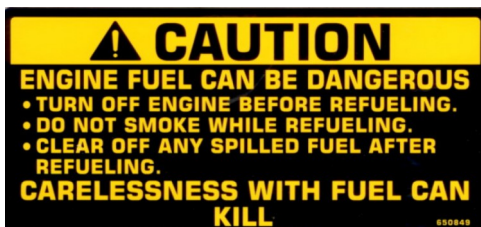

FIG 7.10



FIG 7.11

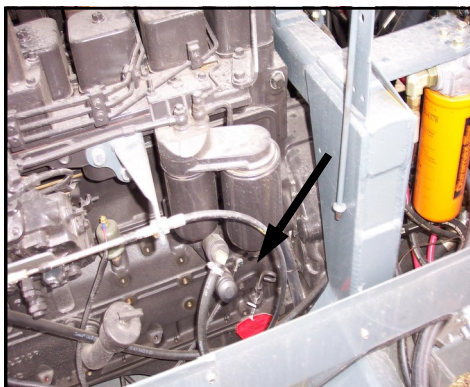

FIG 7.12

**COOLANT RESERVOIR** - The coolant reservoir is located under the right-hand hood behind the radiator (fig 7.9). Check its level everyday while the engine is cold. Maintain the coolant reservoir level within the normal cold range marks.

**CHANGING COOLANT** - Your coolant should periodically be changed to eliminate the buildup of harmful chemicals. Drain and replace the coolant every other detasseling season or every 1,000 hours of operation, whichever comes first. Refill only with ethylene glycol coolant. Antifreeze should be mixed only with soft water because hard water contains minerals which breakdown the anti-corrosion properties of antifreeze.

## Fuel

**TYPE-** No. 2 diesel fuel is recommended for the best economy and performance under most operating conditions. In operating conditions under 32° F, use a blend of No. 1 and No. 2 diesel fuel. The addition of No. 1 diesel fuel may cause loss of power and/or fuel economy.

**STORING** - See section 8 on detasseler storage.

**REFILLING** - Always turn off the engine and allow it to cool before refueling. Never smoke while fueling. Keep a fire extinguisher within reach while refueling (fig. 7,11).

Each tank holds 40 gallons - do not fill them completely: fuel can expand and run over. Wipe up all spilled fuel and clean with detergent and water before starting the engine.

**PRIMING** - If the fuel system should happen to run dry and lose its prime, there is a priming bulb located on the left side of the engine for use in filling the engine fuel filters (fig. 7.12).



# VII. SERVICE AND MAINTENANCE

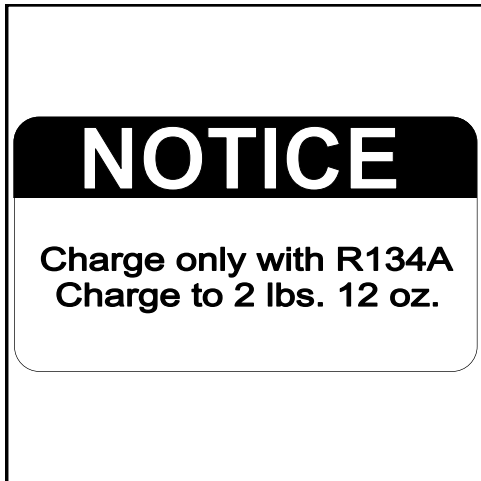

FIG 7.13

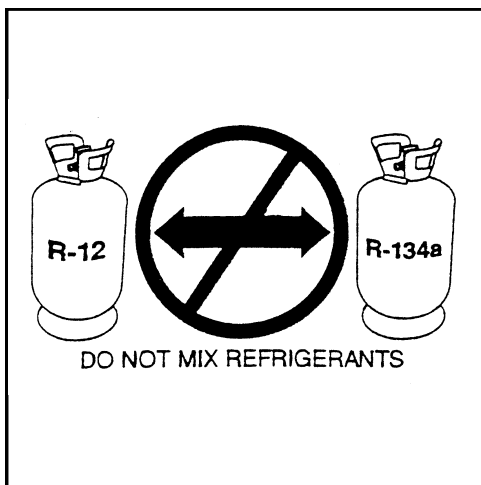

FIG 7.14

## Air Conditioning

**TYPE** - The cab on your detasseler is equipped with a R-134A air conditioning system.

**RECHARGING** - Recharge it only with R-134A refrigerant. If your air conditioning system is mistakenly charged with R-12 refrigerant, serious problems, such as compressor seizure, may result. Therefore, confirm refrigerant before recharging system.

If you do not have the proper recharging equipment, it is recommended that you allow an independent service agent service your air conditioning system.

## FLUID CAPACITIES AND TYPES

Engine oil pan (including filter) .....	15.9 quarts SAE 15W-40
Engine oil dipstick, L-H mark .....	2 quarts
Hydraulic oil reservoir .....	25 gallons anti-wear hydraulic oil
Torque Hub® oil level .....	approx. 16 oz. EP-90
Engine cooling system .....	5.1 gallons ethylene glycol
Fuel tanks (2) .....	40 gallons ea. No. 1 or 2 diesel

# VII. SERVICE AND MAINTENANCE

## FILTERS

### Grille Screens



FIG 7.14

In order to maintain maximum air flow through the engine cooling system's radiator, oil cooler, and air conditioning condenser, the cooling air intake grille screens must be inspected often and periodically removed for cleaning.

**NOTE:**

Failure to keep cooling systems clean can cause over heating and damage to the hydrostatic system and/or engine



FIG 7.15

**REMOVAL** - The side grille screens are easily removed by sliding them up out of their housings (fig. 7.14). The top screen is held in place by two bolts (fig. 7.15) and may also be removed for cleaning.

**CLEANING** - Compressed air will dislodge most large trash or loose dirt after the screens away from the machine. Water from a pressurized hose may also be used (fig. 7.16), or if necessary the screens may be soaked in soapy water and scrubbed with a brush.

**NOTE:**

When cleaning cooling fins of the radiator, oil cooler, or A/C condenser with compressed air or water, be careful not to damage cooling fins which may impair cooling capabilities.



FIG 7.16

# VII. SERVICE AND MAINTENANCE

## FILTERS CONTINUED



FIG 7.17

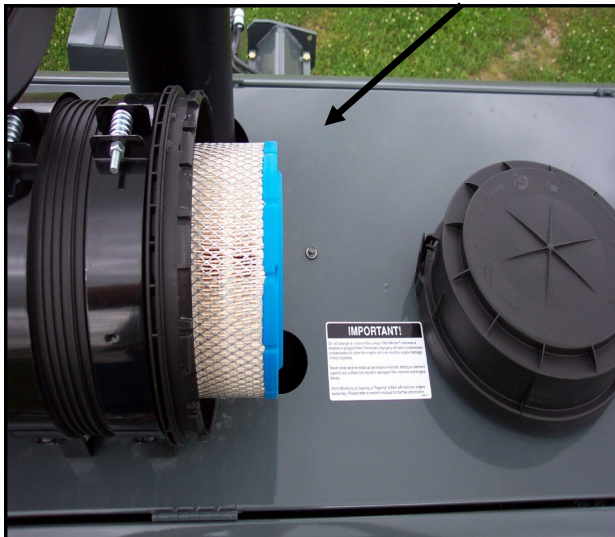

FIG 7.18



FIG 7.19

## Engine Air Intake

**REMOVAL** - The engine air intake filter element should only be removed if it is going to be replaced. After loosening the air cleaner clamp and removing the end cap, carefully remove the filter so as not to knock any dust off the filter and into the air intake passage (fig. 7.18).

**REPLACEMENT** - Your detassler is equipped with a Filter Minder<sup>®</sup> to notify you of filter element efficiency. Follow its guidelines for servicing. (See below.) At appropriate service time, install the new element carefully to ensure proper sealing.

**CLEANING** - It is not recommended to clean the air filter element. However, a clean damp cloth should be used to wipe dust and foreign material from the air cleaner housing before a new element is installed.

## Filter Minder<sup>®</sup>

The Filter Minder<sup>®</sup> is an air restriction monitoring system that progressively and constantly indicates how much air filter capacity remains. Check its reading daily. (fig. 7.19.)

Service the air cleaner when the Filter Minder<sup>®</sup> reads 20" (80% of average dirt holding capacity). Reset the Filter Minder<sup>®</sup> to zero each time you replace the air filter element.

### NOTE:

Service the air cleaner on your detasseler before the yellow indicator reaches the red line on your Filter Minder<sup>®</sup>.

# VII. SERVICE AND MAINTENANCE

## FILTERS CONTINUED

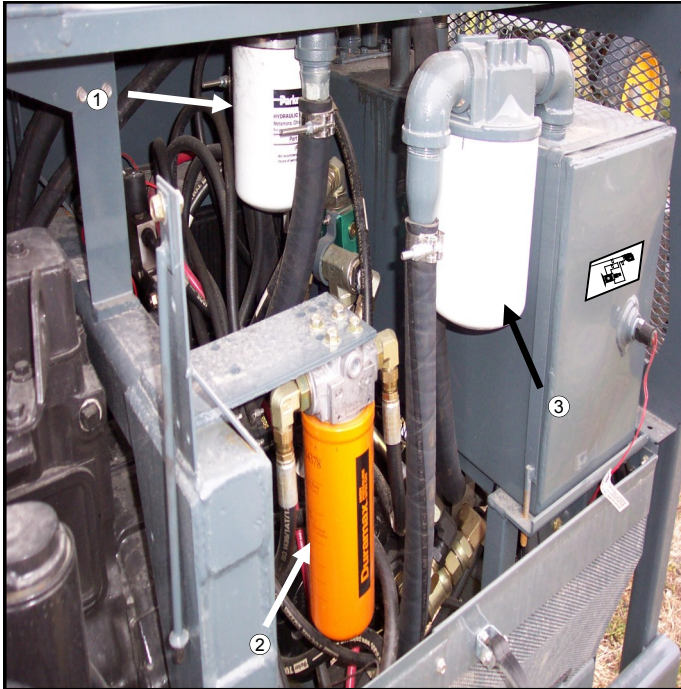

FIG 7.20

### Suction Filter

Remove and install a new 10 Micron rated suction filter (fig. 7.20. item 3) at the end of the first 50 hours of use; subsequently, replace the filter every 250 hours, or once a year, whichever comes first.

### Charge Pressure Filter

Remove and install a new 4 Micron rated charge pressure filter (fig. 7.20, item 2) at the end of the first 50 hours of use; subsequently, replace the filter every 250 hours, or once a year, whichever comes first.

### Return Filter

Remove and install a new 25 Micron rated return filter (fig. 7.20, item 1) at the end of the first 50 hours of use; subsequently, replace the filter every 250 hours, or once a year, whichever comes first.

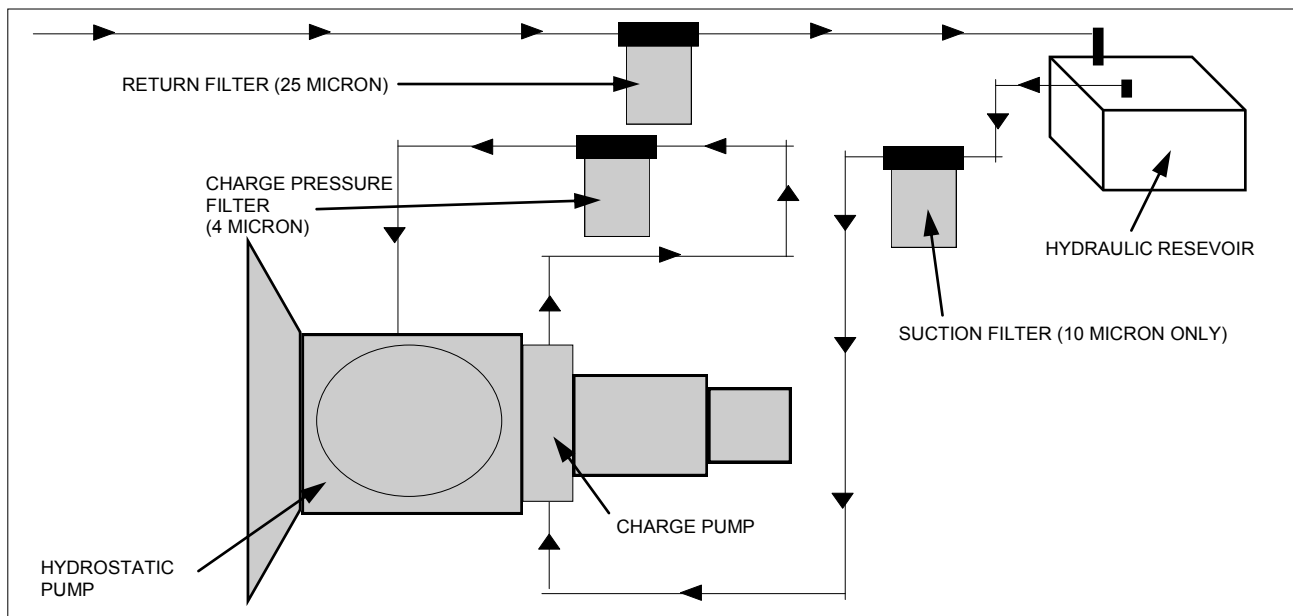

FIG 7.21

# VII. SERVICE AND MAINTENANCE

## FILTERS CONTINUED

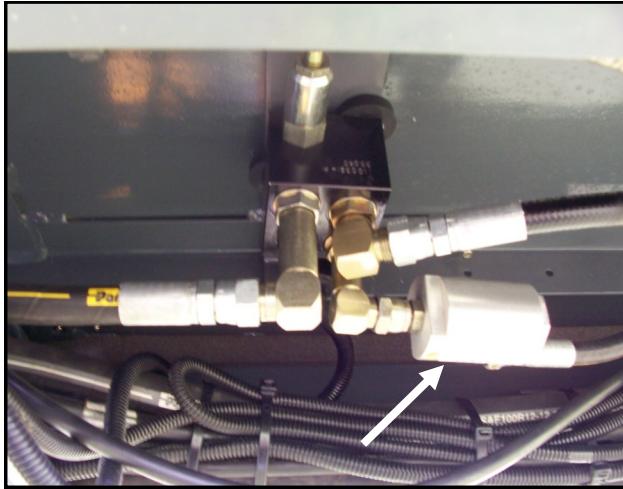

FIG 7.22

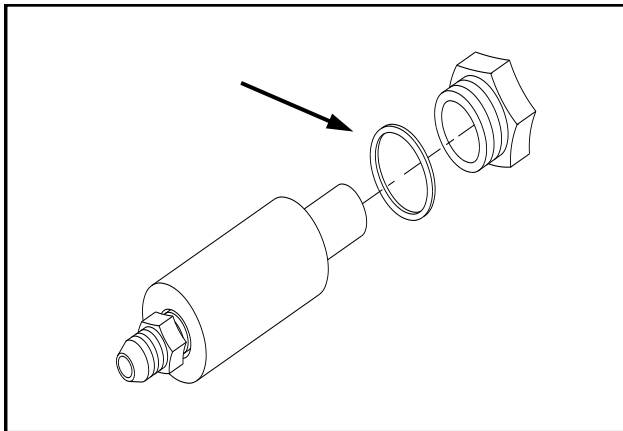

FIG 7.23

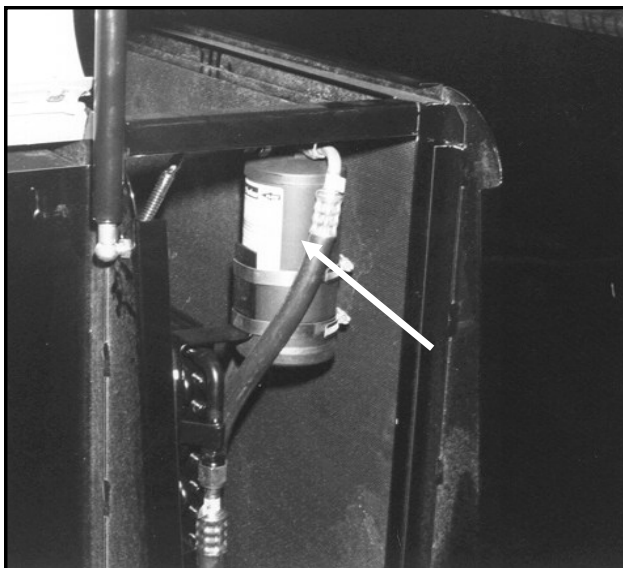

FIG 7.24

## High Pressure In-Line Filters

**LIFT/DUMP VALES** - The valves of the lift control valve system are protected by a 90 Micron in-line sintered bronze filter (fig. 7.22.). When the filter element is removed for cleaning, caution should be taken so the gasket is in the proper place when reinstalling (fig. 7.23.). Also, reinstall filter paying attention to direction of flow so the end marked "OUT" is oriented correctly.

## A/C System Dryer (if equipped)

The A/C system receiver/dryer (fig. 7.24.) should be replaced if the A/C loop is ever opened such as replacing a compressor or condensor line, etc.

# VII. SERVICE AND MAINTENANCE

## FILTERS CONTINUED

### Fuel Filters

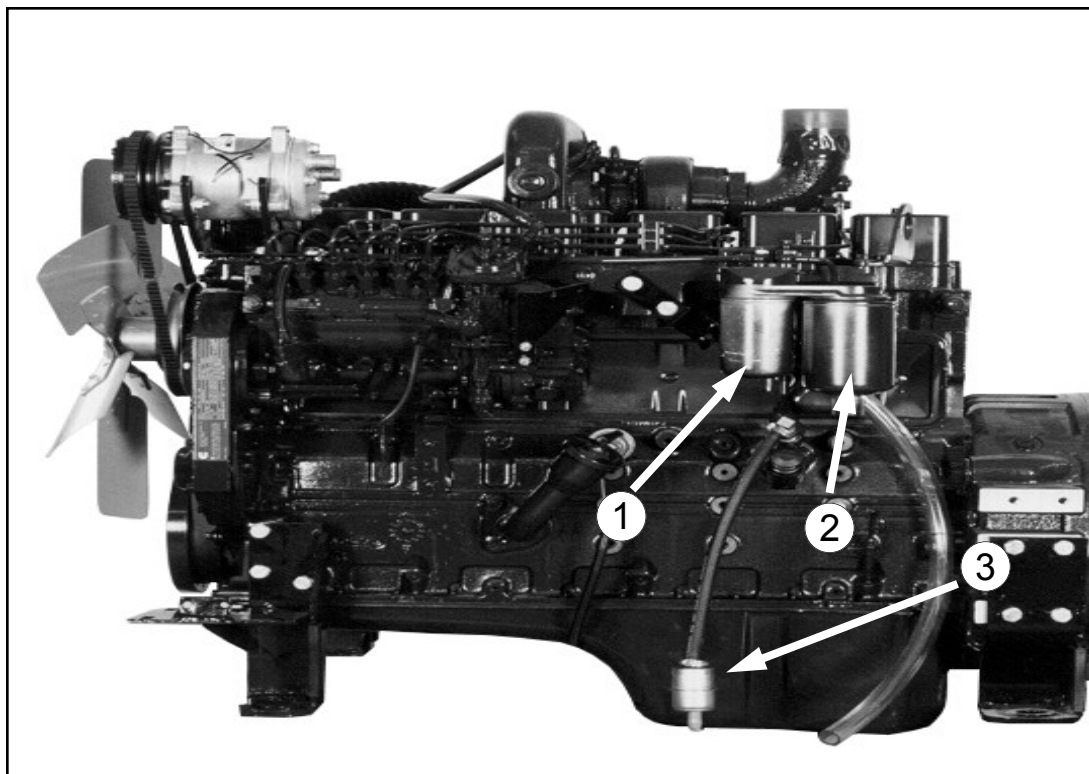

FIG 7.25



FIG 7.26

**PRIMARY (WATER SEPERATOR)** - (fig. 7.25, item 2) Drain water and sediment from the separator daily. Replace every 500 hours or once a year, whichever comes first.

**SECONDARY** - (fig. 7.25, item 1) Replace every 500 hours or once a year, whichever comes first.

**IN-LINE STRAINER** - (fig. 7.25, item 3 fig. 7.26) Note direction of fuel flow arrow when replacing.

# VII. SERVICE AND MAINTENANCE

## FILTERS CONTINUED

### Fresh Air Cab Filters

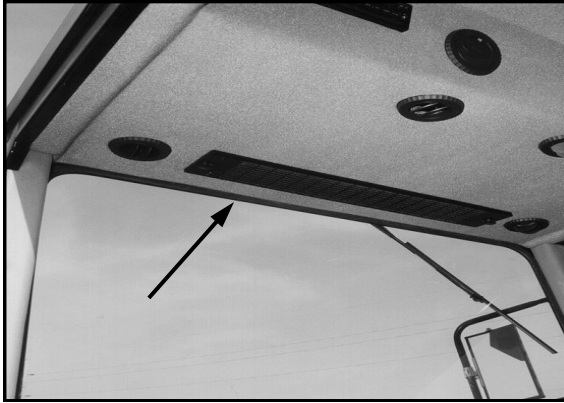

**CAB FILTER LOCATION  
FIG 7.27**

**PAPER FILTER** - (fig. 7.28, item 1) The paper filter should be cleaned once a year, or more often if necessary. Remove the paper element and gently tap it against a flat surface. Direct low pressure compressed air through the filter to remove larger particales. Replace the paper filter if necessary.

**CHARCOAL FILTER** - (fig. 7.28, item 2) Remove and replace at the first sign of chemical oder entering the cab.

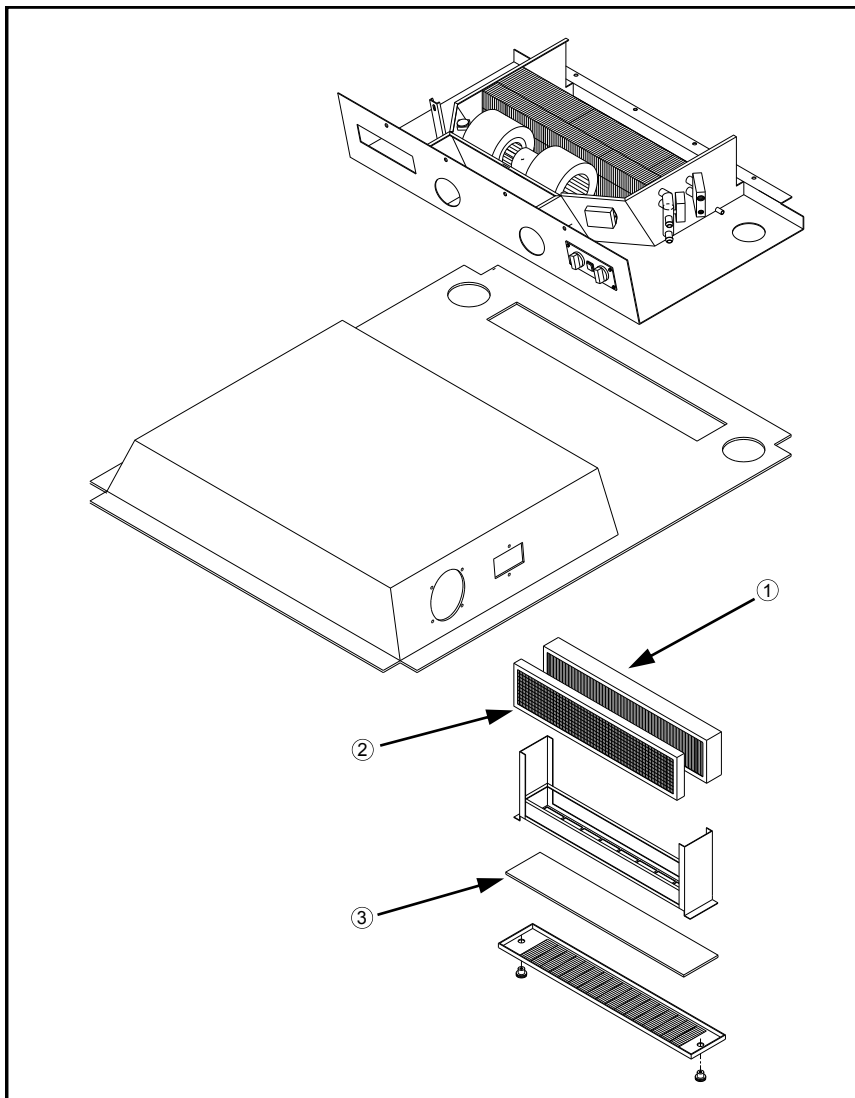

**FIG 7.28**

**RECIRCULATING FILTER-**  
(fig. 7.28, item 3) The recirculating filter may be cleaned with soap and water. Replace if it becomes worn.

# VII. SERVICE AND MAINTENANCE

## LUBRICATION

### Leg Bearings

Hagie 204SP leg assemblies are constructed with upper and lower nylon bearings for suspension telescoping between the inner and outer leg weldments. These bearings must be lubricated to avoid bearing failure and ensure optimal ride quality. There are grease zerks located on the sides of the leg assemblies, one for the upper bearing (fig. 7.29, item 1) and two for the lower bearing (fig. 7.29, item 2). Greasing both bearings on both front and rear legs daily is very important.

During operation of the detasseler, the grease may possibly be wiped off by passing crop leaves, so the bearings should be greased at least twice a day. Suggested times are in the morning and at noon. If the crop is mature enough, or plant population is high enough, more frequent leg bearing grease application may be required. This will ensure proper lubrication allowing optimal performance.

### Torque Hub<sup>®</sup> Seal Boot

Each leg has a seal boot located between the wheel motor and Torque Hub<sup>®</sup>. Seal boot grease zerks (fig. 7.29, item 3) should be greased once every 50 hours or as needed. An over-greased seal boot will leak some grease out around the seal and when heated may cause the appearance of a failed wheel motor leaking hydraulic fluid. Wipe off any excess grease after servicing.

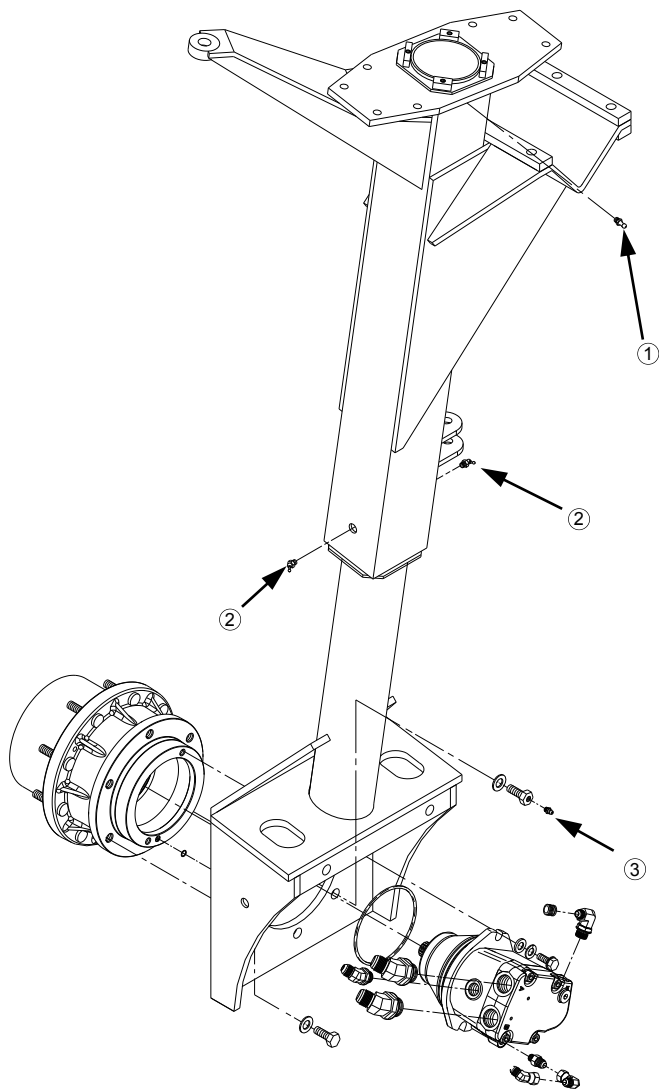

FIG 7.29



# VII. SERVICE AND MAINTENANCE

## LUBRICATION CONTINUED

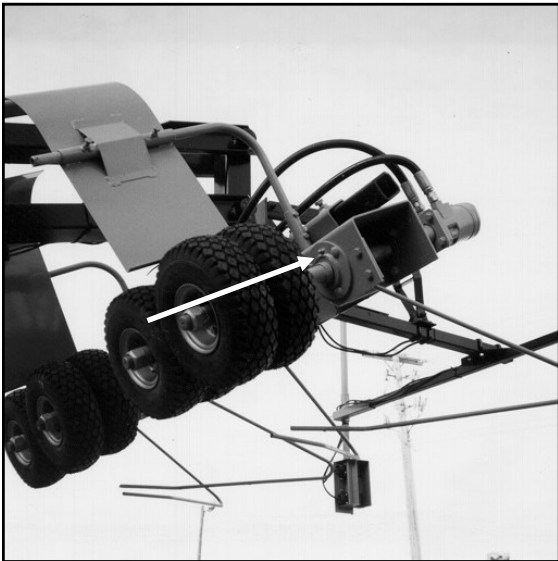

FIG 7.30

### Quad Pullers

Each quad puller head has four bearings equipped with grease zerkers (fig. 7.31). To ensure the longest life and best performance, grease each bearing twice a day: suggested times are morning and noon.

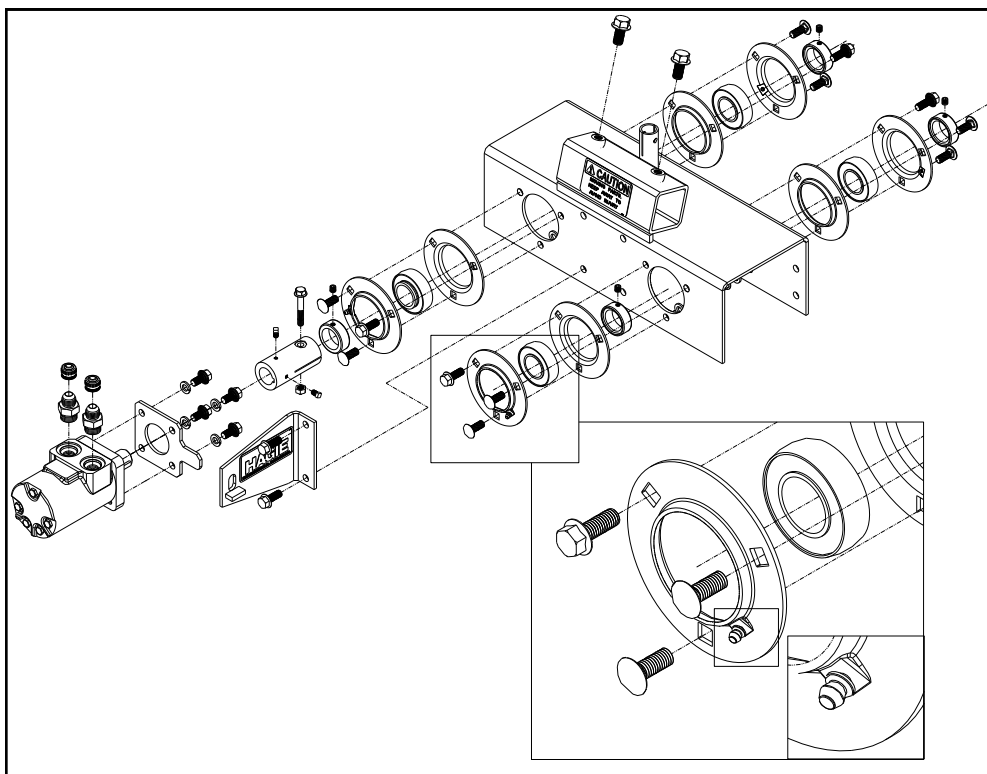

FIG 7.31

# VII. SERVICE AND MAINTENANCE

## ELECTRICAL

### Battery Safety



FIG 7.32



FIG 7.32

RATINGS	
VOLTAGE	12V (only)
CCA (30 SEC @ 0° F)	950
RESERVE CAPACITY	185 MIN. @ 25 AMPS

FIG 7.33



## CAUTION

Batteries contain sulfuric acid. Avoid contact with skin, eyes, or clothing. Do not inhale fumes or ingest liquid. Batteries contain gases which can explode. Keep sparks and flame away while servicing.

### NOTE:

When servicing electrical system always disconnect the battery. Remove ground cable first and connect it last.

**CLEANING** - Disconnect battery cables from battery. Remove all corrosion with a wire brush or battery post brush (fig. 7.31). Wash the cable connections and battery posts with a weak solution of baking soda or ammonia. Apply petroleum jelly or grease to prevent future corrosion. Reconnect the cables to the battery making sure they are tight. Clean every 100 hours.



## CAUTION

Electrical system is 12 volt negative ground. When using booster with jumper cables, precautions must be taken to prevent personal injury or damage to electrical parts.

1. Attach one end of jumper cable to positive terminal of booster battery and other end to positive terminal of vehicle battery connected to starter motor.
2. Attach one end of second cable to negative terminal of booster battery and other end to vehicle frame away from battery. Do not attach to cab or cab support.
3. To remove cables, reverse above sequence exactly to avoid sparks. See operator's manual for additional information.

650982

**STORAGE** - See page 107 for proper battery storage.

**REPLACEMENT** - When replacing the battery, install a battery with ratings equivalent to or higher than the specs listed in figure 7.33.

### NOTE:

To ensure the best electrical contact, battery terminal connections should be as clean and as tight as possible.

# VII. SERVICE AND MAINTENANCE

## ELECTRICAL CONTINUED

### Fuses



FIG 7.34

Fuses protect individual lighter duty electrical circuits. They are located toward the rear console panel to the right of the operator's seat (fig. 7.34).

If a fuse blows, remove it by rotating the fuse cap counterclockwise as you push down. Then pull the fuse straight out (fig. 7.36). Replace each blown fuse with the same amperage fuse only.

Correct fuse location and amperage are shown in figure 7.35. If the fuse continues to blow, determine the cause and correct it.

- Motor control block ..... 20 AMP
- Tasseltr<sup>®</sup> box, seat motor (cab only).... 20 AMP
- Flasher/turn signal, running lights, windshield wiper (cab only),fuel selector valve ..... 20 AMP
- Hydraulic outrigger fold option.....20 AMP

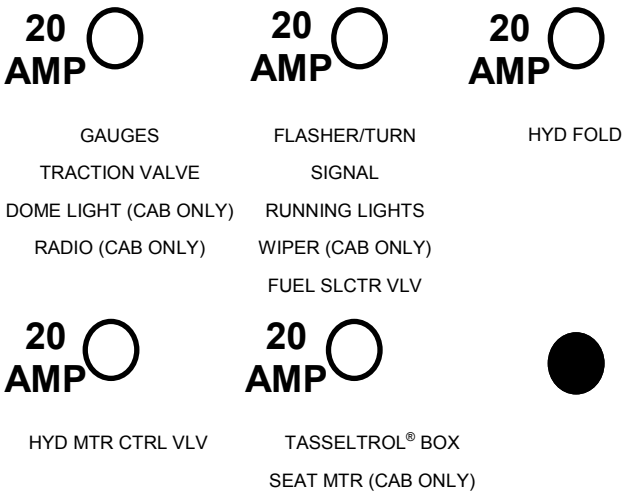

FIG 7.35



FIG 7.36

# VII. SERVICE AND MAINTENANCE

## ELECTRICAL CONTINUED



FIG 7.37

### Depth Command Fuse

The fuse for the DEPTH COMMAND is located in the switch box (fig. 7.37). If the DEPTH COMMAND fuse blows, remove it by rotating the fuse cap counter-clockwise as you push in. Then pull the fuse straight out. Replace the blown fuse with the same amperage fuse only (fig. 7.38).

Operating more than two actuators at one time may cause the fuse to blow (see page 60). A blown fuse may indicate that the LS/DEPTH COMMAND pivot bolts (fig. 7.39) are torqued too tight. If the fuse continues to blow, determine cause and correct it.

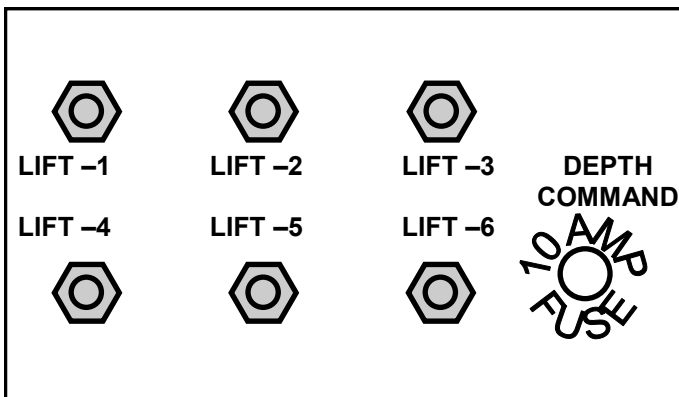

FIG 7.38

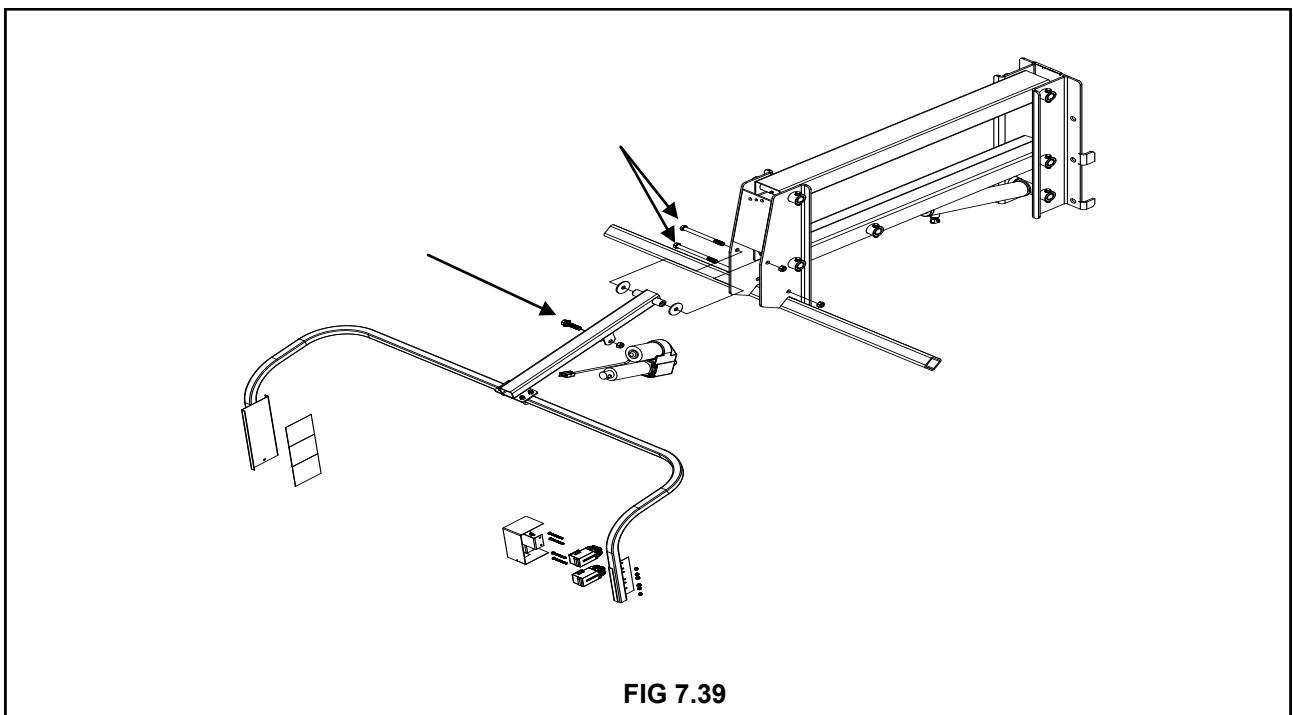

FIG 7.39

# VII. SERVICE AND MAINTENANCE

## ELECTRICAL CONTINUED

### Circuit Breakers

Circuit breakers handle the functions of the heavier duty electrical circuits on the detasseler. They trip when overloaded and automatically reset themselves after they cool down. They will continue to trip and reset as long as the overload or short exists. If the circuit breaker does not reset, replace it with the same amperage breaker only. Correct circuit breaker location and amperage is shown in figure 7.42.

To access the circuit breakers remove the

hydrostatic handle (fig 7.40, item 1), VFC lever knobs (fig. 7.40, item 2), and panel screws (fig. 7.40, item 3). The circuit breakers are located toward the rear of the console.

The wire harness on the diesel engine are protected by circuit breakers mounted on the engine (fig. 7.41).

If the circuit breaker does not reset and continues to trip, determine the cause and correct it.



FIG 7.40

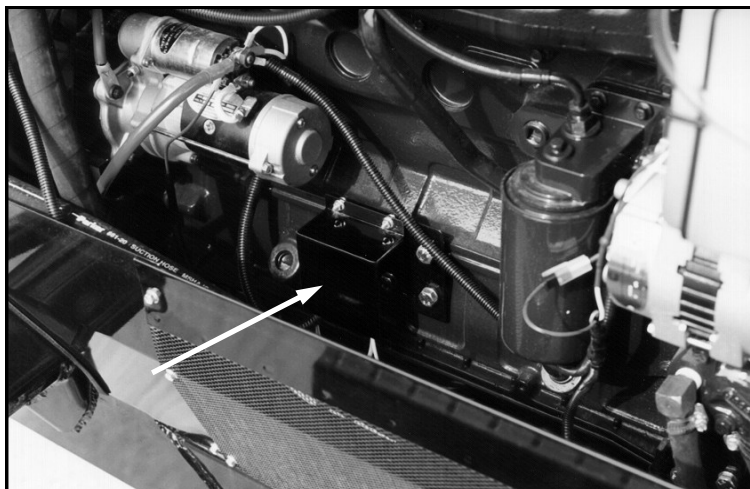

FIG 7.41

A/C relay (cab only).....	30 AMP
Fuel Injector relay .....	40 AMP
Lights.....	40 AMP
Wire harness.....	30 AMP
Wire harness .....	50 AMP
A/C breaker (cab only).....	30 AMP

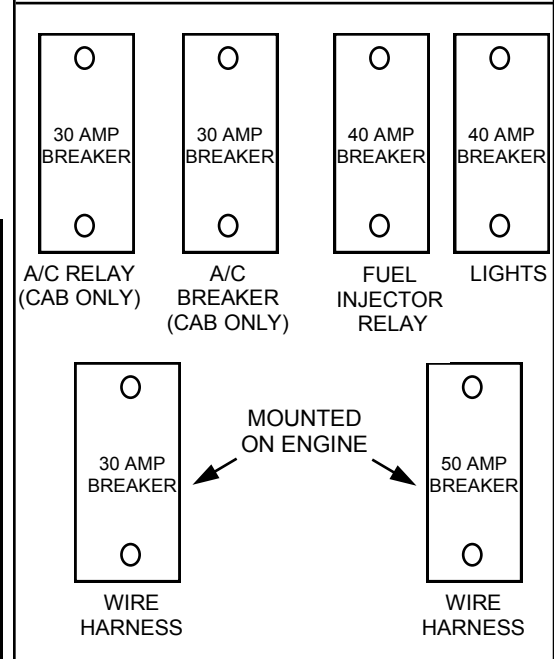

FIG 7.42

# VII. SERVICE AND MAINTENANCE

## BELTS

### Engine Drive Belt

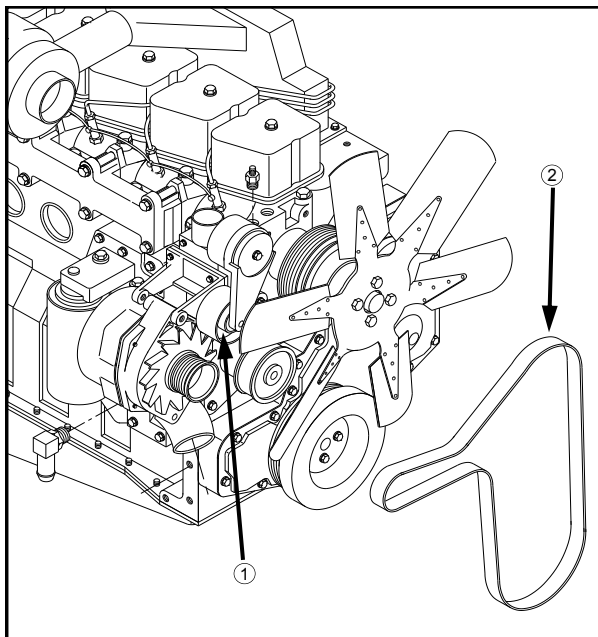

FIG 7.43

**REMOVAL** - Insert a 3/8 inch square ratchet drive into the belt tensioner (fig. 7.43, item 2).

**INSPECTION** - Visually inspect the belt daily (fig. 7.44). Check the belt for intersecting cracks (fig. 7.44). Transverse (across the belt width) cracks are acceptable. Longitudinal (direction of the belt length) cracks that intersect with longitudinal cracks are not acceptable. Replace the belt if it is frayed or has peices of material missing.

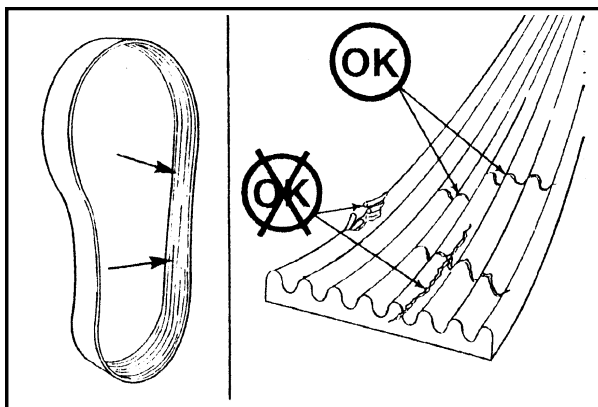

FIG 7.44

### A/C Compressor Belt (if equipped)

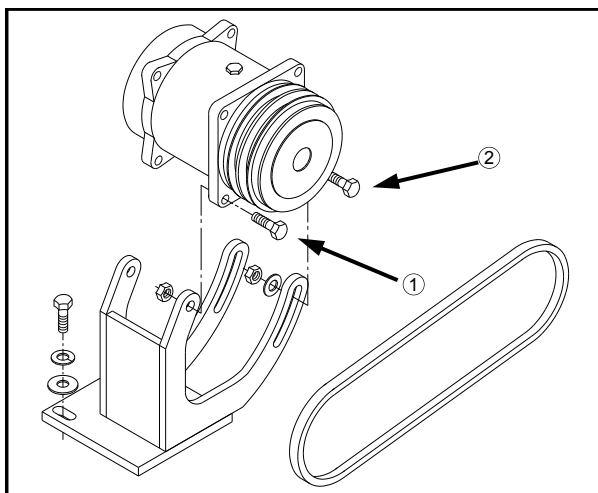

FIG 7.45

To tighten air conditioner belt, loosen the two pivot bolts (fig. 7.45, item 1) and the two slide bolts (fig. 7.45, item 2). Using a suitable prying tool, adjust tension on the belt to desired tautness. While maintaining tension, re-tighten all four bolts. Inspect the belt every 250 hours.

# VII. SERVICE AND MAINTENANCE

## DRIVE TRAIN

### Hydrostatic Pump

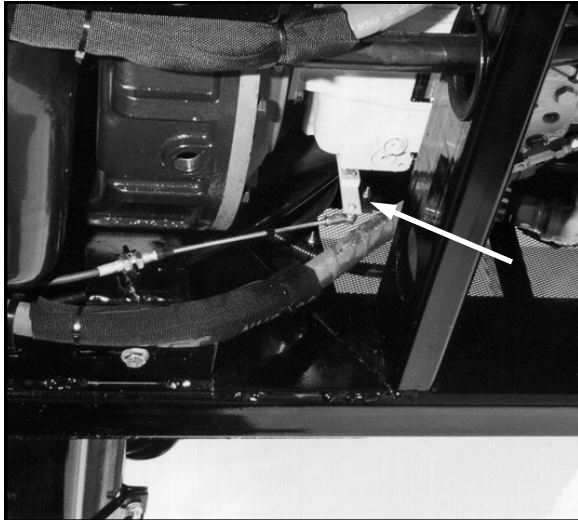

FIG 7.46

**NEUTRAL SETTING** - When the hydrostatic lever is in the neutral position, the machine should not be moving in either direction. If it does, the neutral setting of the lever (fig. 7.46) on the hydrostatic pump needs to be adjusted.

**CHECK CHARGE PRESSURE** - See page 37.

**REPAIR/REPLACEMENT** - Hydrostatic are available as a core exchange item from Hagie Manufacturing Customer Support Department.

### Auxiliary Gear Pumps

**REPAIR/REPLACEMENT** - Gear pumps are available from the Hagie Manufacturing Customer Support Department.

### Wheel Motors

**REPAIR/REPLACEMENT** - Wheel motors are available as a core exchange item from Hagie Manufacturing Customer Support Department.

### Torque Hubs<sup>®</sup>

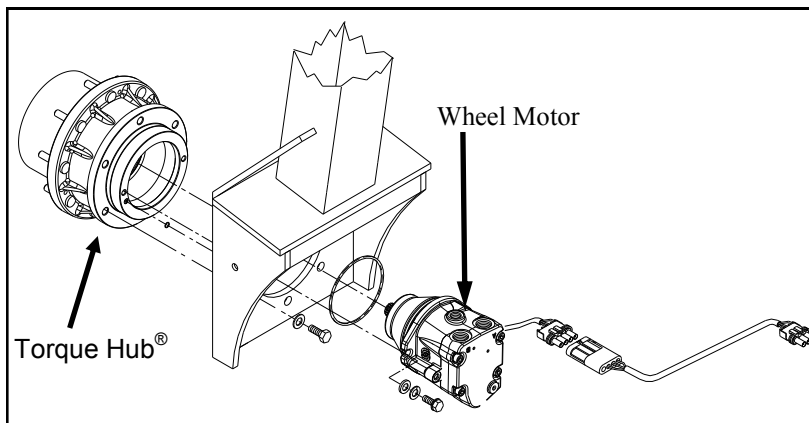

FIG 7.47

**GREASE** - Grease according to page 93.

**OIL** - Maintain oil level according to page 83.

**REPAIR/REPLACEMENT** - Call the Hagie Manufacturing Customer Support Department for parts and repair.

# VII. SERVICE AND MAINTENANCE

## BOLT TORQUE



FIG 7.48

### Wheel Bolts

To install wheel and tire assembly on the Torque Hub<sup>®</sup>, lubricate Torque Hub<sup>®</sup> studs with anti-seize grease. Align the wheel bolt holes with the Torque Hub<sup>®</sup> studs and mount the wheel on the hub.

#### NOTE:

To achieve even torque consistency, the tire should be completely off the ground.

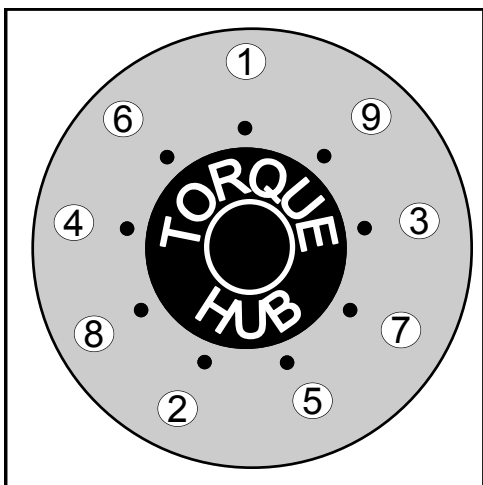

FIG 7.49

Start all of the lug nuts on and tighten them until they are just snug. Following the torque sequence in figure 7.49, first turn each lug nut to a torque value of 120 dry foot-pounds. Use slow even pressure on the torque-wrench. Quick or jerky movements cause inaccurate values. Repeat the same sequence to 150 dry foot-pounds and again finally to 180 dry foot-pounds.



### CAUTION

Check lug nut torque immediately after receiving machine and every 50 hours thereafter.

If the wheel turns during lug nut torquing, lower the machine to the ground just enough for the tire to touch and prevent rotation or more preferably, place a suitable wedge between the tire and the ground.

Lower the machine and resume operation. Recheck torque after 30 minutes of operation.



FIG 7.50

**Keep wheel bolts tight. See owner's manual for torque specifications.**



# VII. SERVICE AND MAINTENANCE

## BOLT TORQUE CONTINUED

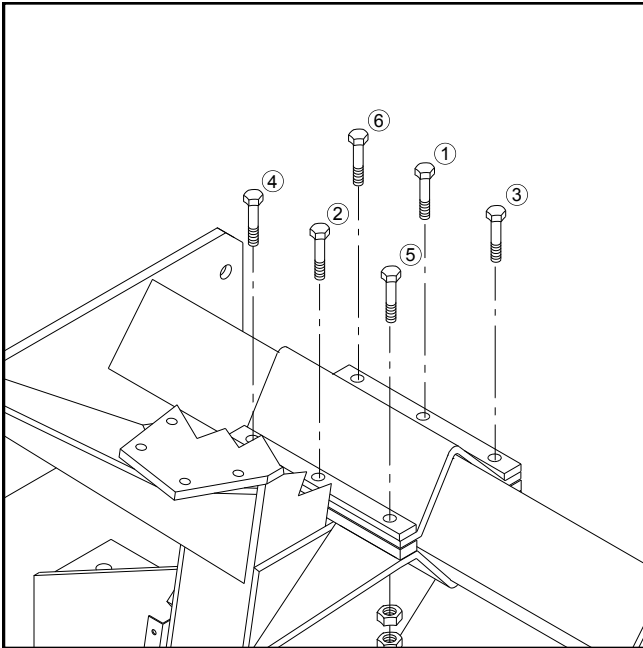

FIG 7.51

### Leg Mounting Bolts

Follow these procedures for torquing the leg mounting bolts:

Start the nuts on the mounting bolts and tighten them until they are just snug. Following the torque sequence in figure 7.51, turn each lug nut to a value of 100 dry foot-pounds. Use slow even pressure on the torque wrench. Quick or jerky movements cause inaccurate values.



### CAUTION

Never remove more than three leg mounting bolts from any single leg mount.



FIG 7.52

Lower the detasseler to the ground and repeat the same sequence to 130 dry foot-pounds and again finally to 160 dry foot-pounds.

Resume operation and recheck torque values after 30 minutes of operation.

# VII. SERVICE AND MAINTENANCE



FIG 7.53

## TIRES

### Air Pressure

Check tire pressure once a week or every 50 hours of operation (fig. 7.53). Never inflate a tire more than the recommended maximum air pressure. Use an air line with a locking air chuck and stand behind the tire tread while filling (fig. 7.54).

#### NOTE:

Tire pressure will depend on load quantity due to various options installed. Refer to page 20 for tire specifications.



FIG 7.54



## WARNING

When inflating tire, use extension hose with in-line air gauge and clip on air chuck, which will allow operator to stand clear of tire side explosion trajectory.

### Wheel Bolts

See page 109 for recommended wheel bolt torque specifications and torquing pattern.

### Mounting

If you do not have proper mounting equipment, let your local qualified tire sales/serviceman dealer mount the tire for you. Tire should be mounted on rim according to figure 7.55 for best traction and tread cleaning action.

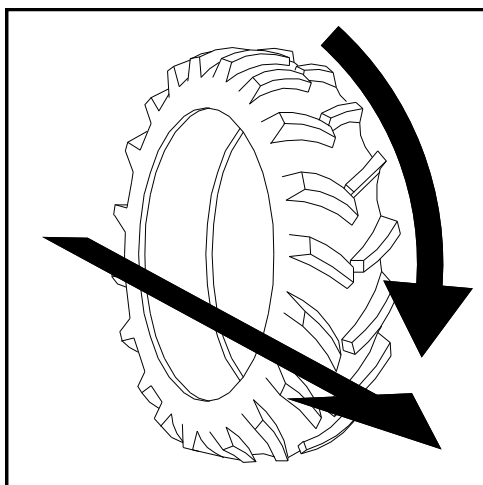

FIG 7.55

### Toe In

See pages 33 and 112 for information regarding toe-in measurement and adjustment.

# VII. SERVICE AND MAINTENANCE

## TOE-IN ADJUSTMENT

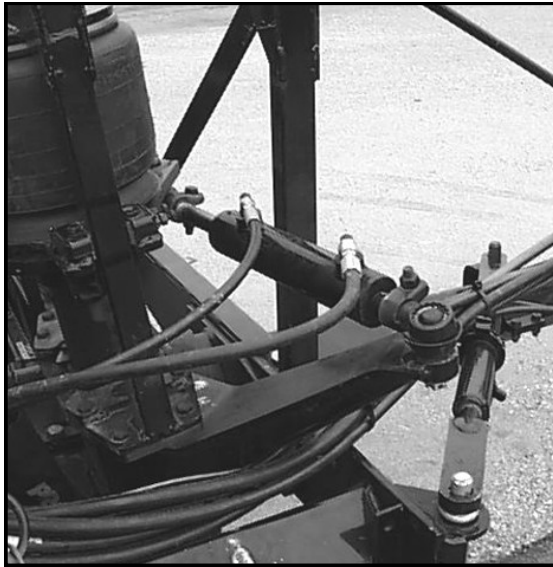

FIG 7.56

To adjust to toe-in of the front tires follow these instructions for both front steering cylinders carefully:

1. Remove cotter pin (fig. 7.57, item 5), castle nut (fig. 7.57, item 3), and lock washer (fig. 7.57, item 4).
2. Loosen lock collar bolt and nut (fig. 7.57, item 2).
3. Lightly tap swivel assembly (fig. 7.57, item 1) out of steering arm.
4. Move left and right tires evenly until the difference in dimension "A" and "B" (fig. 7.58) are within specified range.

### NOTE:

Dimension "A" should be  $\frac{1}{2}$ " to  $\frac{3}{4}$ " less than dimension "B". For more information regarding toe-in see page 33.

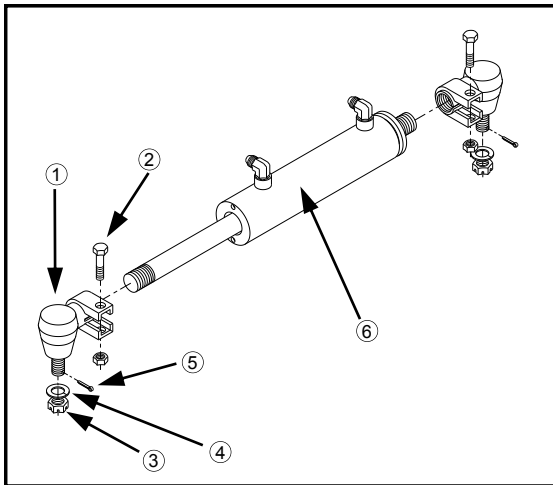

FIG 7.57

5. Screw swivel assembly in or out on steering cylinder (fig. 7.57, item 6) until the tread part lines up with the steering arm.
6. Insert swivel assembly into steering arm.
7. Install lock washer and castle nut and tighten.
8. Install cotter pin.
9. Tighten lock collar bolt.

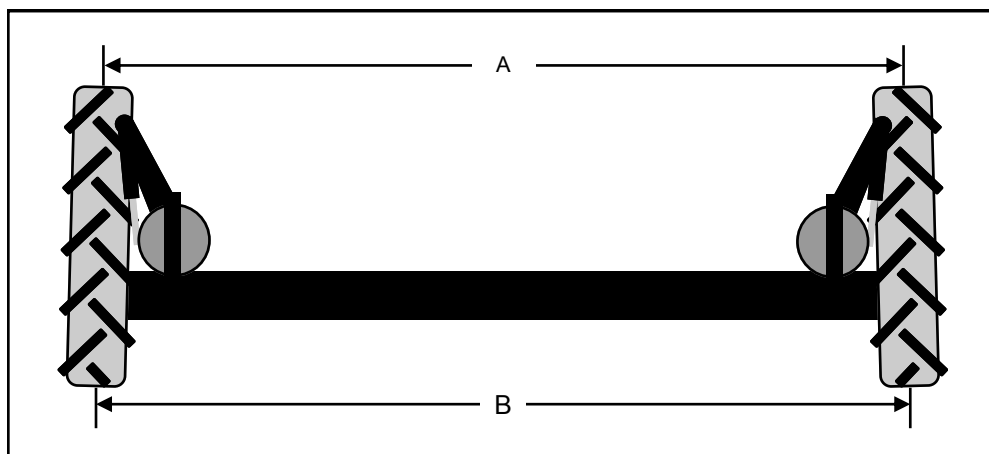

FIG 7.58



# VII. SERVICE AND MAINTENANCE

## SUSPENSION

### Air-Ride Adjustment

Park the machine on level ground with outriggers completely unfolded in field operating position. Adjust the air pressure in each bag until the distance between the bottom of the steering plate (fig. 7.59, item 1) and the top of the bumper pad strike plate (fig. 7.59, item 2) is 6 inches. With a clear path on level ground, drive the machine forward 100 yards, cycling the steering back and forth, shifting machine weight from side to side. Stop on level ground and remeasure, adjust as necessary. Repeat procedure until desired measurement is achieved.

Visually check each air bag height often and adjust if necessary. Check each bag height with a tape measure daily and adjust if necessary.

The amount of pressure in the airbags will depend on the options on the machine, but should be around 42 PSI in the front and 24 PSI in the back. You want the pressure to be enough that the tie rods and steering cylinders are level (fig. 7.61). Over inflated and under inflated airbags will cause stress to the machine resulting in damage.

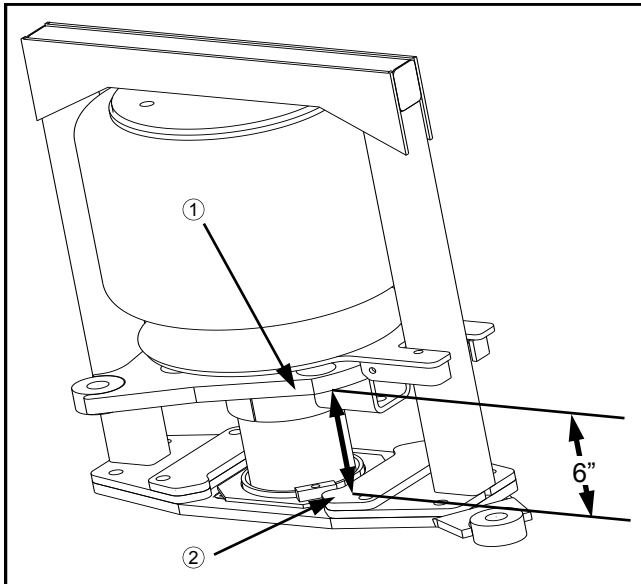

FIG 7.59



FIG 7.60



FIG 7.61



# VII. SERVICE AND MAINTENANCE

---

## DAILY INSPECTION

Inspection Point	Action (if necessary)
<b>Check</b>	
Engine oil level.....	Add oil
Radiator coolant level.....	Add antifreeze solution
Coolant overflow reservoir level.....	Add antifreeze solution
Engine drive belt .....	Replace belt
Filter Minder®.....	Replace air filter element
Hydraulic reservoir level.....	Add hydraulic oil
Neutral setting on hydrostatic pump .....	Adjust setting
Visual inspection of leg mounting bolts .....	Tighten
Visual inspection of air bag height .....	Adjust height
Battery.....	Clean or tighten
Radiator grille screens .....	Remove and clean
Look for loose or missing items such as shields.....	Tighten or replace
Look for any fluid leaks pooled on machine or ground .....	Determine cause and correct
Quad puller tire pressure (if equipped)(4 places each row).....	Add air
Cutter blade retaining bolt.....	Tighten
<b>Grease</b>	
Upper and lower leg bearings .....	See page 101
Quad puller bearings (if equipped) (4 places).....	See page 102
<b>Drain</b>	
Fuel/water separator .....	See page 99

# VIII. STORAGE

---

## Preparing the detasseler for storage.

1. Perform daily level checks, lubrication, and bolt and linkage inspections as required in this manual in section seven on maintenance.
2. Every other season, drain the coolant from the engine and radiator. Probe the drain holes during draining to ensure they are not clogged by sludge, scale, or other deposits. Fill the cooling system to the top with a 50/50 water /antifreeze mixture. Run to operating temperature and re-check level.

**NOTE:**

If antifreeze is added, make sure the engine is then run to operating temperature to assure proper mixing of solution.

3. Add a fuel stabilizer to the fuel and fill the fuel tank.
4. Run the engine until it is at operating temperature, then drain the engine oil. Refill with fresh oil of recommended weight and install a new lubricating oil filter element.
5. With the engine at normal operating temperature, cycle all hydraulic functions including the steering.
6. Release tension on belts.
7. Use plastic bags and water-resistant adhesive tape to seal the air intake opening, all exhaust manifold openings, engine oil filler cap, hydraulic oil tank breather cap, and fuel tank caps.
8. Disconnect and remove the battery or batteries. Completely clean and charge the battery. Coat the terminals with petroleum jelly and store battery in cool, dry place.
9. Thoroughly clean the detasseler. Touch up any painted surfaces that are scratched or chipped. For touch up paint recommendations contact Hagie Manufacturing Customer Support Department.
10. Replace worn or missing decals. See pages 7-19 for proper location of warning decals are available through Hagie Manufacturing Customer Support Department.

**NOTE:**

For replacement decals contact:  
Hagie Manufacturing Company  
721 Central Ave West  
Box 273  
Clarion, IA 50525-0273  
Ph. 1-800-247-4885

# VIII. STORAGE

---

## STORAGE CONTINUED

11. Use a multi-purpose grease to coat the exposed hydraulic cylinder rods to prevent rusting which could result in cylinder damage.
12. If the sprayer must be stored outdoors, cover it with a water proof cover.

### Removing the detasseler from storage.

1. Inspect the condition, and test the air pressure, of all tires. Please see page 109 for information regarding proper tire maintenance.
2. Carefully unseal all openings that were sealed in the storage process.
3. Clean and reinstall the battery. Be sure to attach the battery cables to the proper battery terminals.
4. Tighten all belts. Inspect and replace any worn belts. For information on belts, see page 107.
5. Check the engine oil, hydraulic oil, and engine coolant levels; add, if necessary. A mixture of 50/50 antifreeze and water will cool adequately in the summer as well as protect in the winter.

**NOTE:**

Protective compounds such as grease can harden under exposure to weather conditions.

6. Completely clean the detasseler.
7. Review section on maintenance (pages 86-114), and perform all needed services as instructed.
8. For starting instructions, see pages 42-43 in section five on operating information.

**NOTE:**

See Warranty on page 134 concerning **improper storage**.

# IX. TROUBLE SHOOTING

---

## A. ENGINE



### CAUTION

Start engine from operator's seat only. When running engine in a building, be sure there is adequate ventilation.

PROBLEM	POSSIBLE CAUSE	SUGGESTED REMEDY
Engine won't crank	Dead battery  Poor battery connections  Neutral safety switch (located in the Sauer/Sundstrand pump)  Starter or starter relay  Lock out switch in locked position	Recharge or replace battery  Clean and tighten  Adjust and/or replace if needed  Test; rebuild or replace  Check switch
Engine won't start	Out of fuel  Clogged fuel filters  Cold weather  Low starter speed	Fill fuel tank  Replace fuel filters  Refer to engine manual for cold weather starting information  Check starter and battery



# IX. TROUBLE SHOOTING

## ENGINE CONTINUED

PROBLEM	POSSIBLE CAUSE	SUGGESTED REMEDY
Engine overheats	<p>Engine overloaded</p> <p>Dirty radiator core or dirty grill screens</p> <p>Faulty radiator cap</p> <p>Loose or faulty fan belt</p> <p>Faulty thermostat</p> <p>Low coolant level</p>	<p>Reduce load</p> <p>Remove all foreign material and clean all items</p> <p>Replace cap</p> <p>Tighten or replace fan belt</p> <p>Replace thermostat</p> <p>Refill to proper level with recommended coolant</p>
Engine misfires: runs uneven, low power	<p>Water in fuel</p> <p>Dirty air cleaner element</p> <p>Poor grade of fuel</p> <p>Fuel tank vent clogged</p> <p>Clogged fuel filter</p>	<p>Drain, flush, replace filter, fill system</p> <p>Replace element</p> <p>Drain system; change to better grade</p> <p>Open fuel tank vent in cap</p> <p>Replace fuel filter</p>
Engine knocks	<p>Low oil level in crankcase</p> <p>Cold engine</p>	<p>Add oil to full mark</p> <p>Allow proper warm-up period;</p>

# IX. TROUBLE SHOOTING

## B. HYDROSTATIC SYSTEM

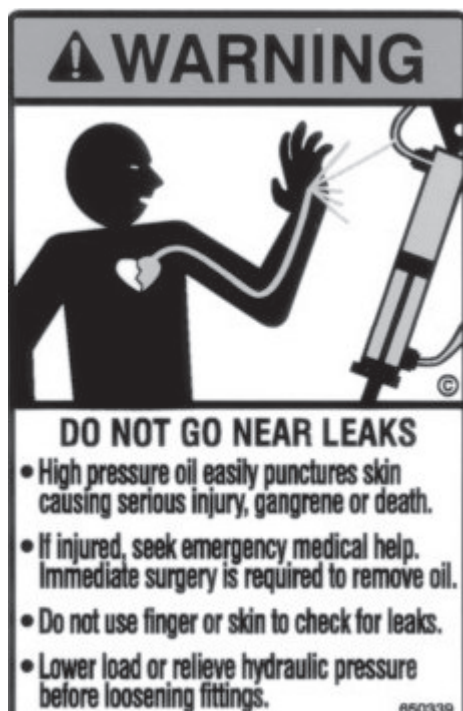

PROBLEM	POSSIBLE CAUSE	SUGGESTED REMEDY
Machine won't move in either direction	<p>Engine speed too low</p> <p>Oil level in reservoir low</p> <p>Control linkage</p> <p>Clogged filter</p> <p>Hydrostatic pump not turning</p> <p>Faulty hydrostatic pump</p> <p>Air leak in suction line</p> <p>Low charge pressure</p>	<p>Set engine at operating RPM before trying to move machine</p> <p>Fill reservoir to proper level w/ approved oil; see section on Service and Maintenance</p> <p>Repair or replace</p> <p>Replace filter</p> <p>Check drive coupling</p> <p>Replace pump</p> <p>Inspect and tighten all fittings on suction line</p> <p>See section under charge pressure (page 38)</p>
Machine will move in only one direction	Faulty flow divider valve	Replace faulty valve.

# IX. TROUBLE SHOOTING

## HYDROSTATIC SYSTEM CONTINUED

PROBLEM	POSSIBLE CAUSE	SUGGESTED REMEDY
Hydrostatic system responding slowly	<p>Engine speed too low</p> <p>Oil level in reservoir low</p> <p>Cold oil</p> <p>Plugged filter</p> <p>Partially restricted suction line</p> <p>Internal damage</p>	<p>Set engine at operating RPM before trying to move machine</p> <p>Fill reservoir to proper level with approved oil; see section on Service and Maintenance</p> <p>Allow for adequate warm-up period</p> <p>Check and replace filter</p> <p>Inspect for collapsed suction hose</p> <p>Replace hydrostatic pump or motor</p>
Noisy hydrostatic system	<p>Cold oil</p> <p>Low engine speed</p> <p>Oil level in reservoir low</p> <p>Air in system</p> <p>Internal damage to pump</p>	<p>Allow for adequate warm-up period</p> <p>Increase engine speed</p> <p>Fill reservoir to proper level with approved oil; see section on Service and Maintenance</p> <p>Inspect and tighten all fittings on suction line</p> <p>Replace pump</p>
External oil leaks	<p>Loose or faulty fittings</p> <p>Damaged O-ring</p> <p>Faulty hose</p>	<p>Tighten or replace</p> <p>Inspect; if damaged replace</p> <p>Replace hose</p>

# IX. TROUBLE SHOOTING

## C. HYDRAULIC SYSTEM

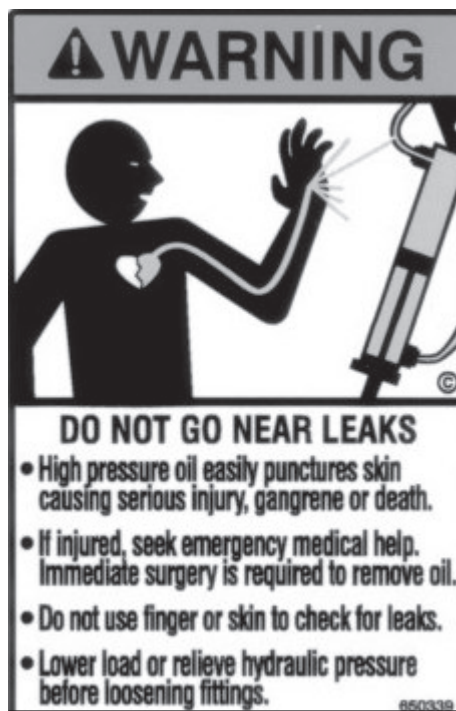

PROBLEM	POSSIBLE CAUSE	SUGGESTED REMEDY
Entire hydraulic system fails to function	Oil level in reservoir low  Oil not reaching pump  Faulty hydraulic pump	Fill reservoir to proper level with approved oil; see section on Service and Maintenance  Prime the pump by removing suction hose from reservoir; hold removed end higher than pump; hand feed two (2) quarts approved oil through suction hose by bumping engine w/ starter (careful not to start engine); re-install hose; tighten all fittings  Replace hydraulic pump
Noisy hydraulic pump	Collapsed suction hose caused by cold oil  Oil level in reservoir low  Air leak in suction line	Allow for adequate warm-up period  Fill reservoir to proper level with approved oil; see section on Service and Maintenance  Inspect and tighten all fittings on suction hose

# IX. TROUBLE SHOOTING

## HYDRAULIC SYSTEM CONTINUED

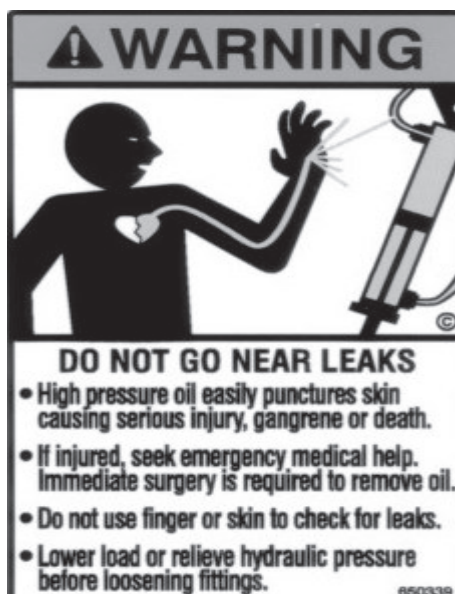

PROBLEM	POSSIBLE CAUSE	SUGGESTED REMEDY
Lifting mechanism won't lift	<p>Bad Cylinder</p> <p>Blown relief valve</p> <p>Relief valve set too low</p> <p>Lift arms frozen</p> <p>Faulty electro-hydraulic valve</p>	<p>Check cylinder; remove and rebuild or replace</p> <p>Remove, check; replace w/ new</p> <p>Reset to 2000 PSI</p> <p>Loosen mounting bolts; lubricate grease fittings if equipped</p> <p>See Tasselrol®/LS and/or Tasselrol® trouble shooting guide</p>
Cutter head blades, quad pullers, rollers, or tires won't turn	<p>Oil level in reservoir low</p> <p>Oil not reaching pump</p> <p>Faulty hydraulic pump</p> <p>Faulty hydraulic motor or motors</p>	<p>Fill reservoir to proper level with approved oil</p> <p>Remove suction hose from pump, check for proper flow. Reinstall hose; all suction fittings</p> <p>Replace hydraulic pump</p> <p>Replace motor or motors</p>
Hydraulic motor leaking	<p>Seal failure</p> <p>Restricted case drain hose</p>	<p>Replace seal; turn heads on with low engine RPM</p> <p>Inspect or replace hose</p>

# IX. TROUBLE SHOOTING

## D. ELECTRICAL



### CAUTION

Batteries contain sulfuric acid. Avoid contact with skin, eyes, or clothing. Do not inhale fumes or ingest liquid. Batteries contain gases which can explode. Keep sparks and flame away while servicing.

### NOTE:

Disconnect battery when servicing any part of electrical system to prevent system damage.

PROBLEM	POSSIBLE CAUSE	SUGGESTED REMEDY
Entire electrical system is dead	Dead battery Poor battery connection Low charging rate No charging rate Lock out switch is in locked position	Charge or replace Clean and tighten Tighten alternator belt Replace alternator Check switch
All gauges on instrument panel not working	Blown fuse Poor ground	Replace fuse Clean and tighten ground
Tachometer/MPH Indicator not working	Blown fuse Loose connections at sensor/alternator Faulty sensor	Replace fuse Tighten or replace connectors Replace sensor
Light system does not function	Blown fuse Poor ground Burned-out bulb Separation or short in wire Faulty switch	Replace fuse Clean and tighten ground Replace bulb Check continuity and replace wire Replace switch

# IX. TROUBLE SHOOTING

## E. HAGIE TASSELTROL® / LS SYSTEM – HYDRAULIC

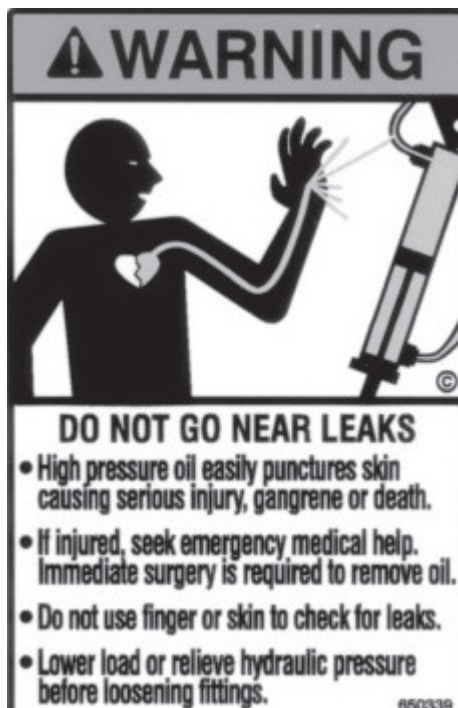

PROBLEM	POSSIBLE CAUSE	SUGGESTED REMEDY
No units will lift	Oil level in reservoir low  Faulty valve  Relief valve in electro-hydraulic valve set too low	Fill tank to proper level  Repair or replace valve  Contact Hagie Customer Support
No units will lower	All lift arm pivots too tight	Lubricate and loosen pivot points
Only one unit will not lower	Faulty valve  Lift arm pivot too tight	Replace valve  Lubricate and loosen pivot point

# IX. TROUBLE SHOOTING

## HAGIE TASSELTROL®/LS SYSTEM – HYDRAULIC CONTINUED

PROBLEM	POSSIBLE CAUSE	SUGGESTED REMEDY
All units lift slowly	<p>Hydraulic oil not at operating temperature</p> <p>Faulty valve</p> <p>Lift arm pivots too tight</p> <p>Plugged high pressure filter</p> <p>Relief valve in electro-hydraulic valve system set too low</p>	<p>Allow time for oil to warm up</p> <p>Replace valve</p> <p>Lubricate and loosen pivot point</p> <p>Remove, clean, replace (see page 90)</p> <p>Contact Hagie Customer Support</p>
Only one unit lifts slowly	<p>Faulty valve</p> <p>Lift arm pivots too tight</p>	<p>Replace valve</p> <p>Lubricate and loosen pivot point</p>
Only one unit will not hold position	<p>Oil leak between valve and cylinder</p> <p>Faulty valve</p> <p>Faulty lower poppet on lift valve</p>	<p>Repair leak or replace hose</p> <p>Replace valve</p> <p>Remove, clean, replace</p>
No units will hold position	Problem is not hydraulic	See Tasseltról® – elect. section



# IX. TROUBLE SHOOTING

## HAGIE TASSELTROL®/LS SYSTEM – HYDRAULIC CONTINUED

PROBLEM	POSSIBLE CAUSE	SUGGESTED REMEDY
Only one unit lowers slowly	Faulty valve Faulty lower poppet on lift valve	Replace valve Remove, clean, replace
All units lower slowly	Hydraulic oil not at operating temperature	Allow time for oil to warm up
In “Manual” mode, more than one unit lifts or lowers from one up/down switch	Faulty valve	Replace valve
In “Auto” mode, more than one unit raises from photo sensor	Faulty valve	Replace valve
In “Auto” mode, wrong unit raises from photo sensor	Cylinder hoses are connected to wrong cylinder	Attach correct hose to proper cylinder

# IX. TROUBLE SHOOTING

## F. HAGIE TASSELTRON<sup>®</sup>/ LS SYSTEM – ELECTRICAL

### MACHINE VALVE TYPE

**o** = any machines with the original valve model year 2007 and prior

**p** = 204/204SP machines with the new proportionate valve model year 2008 and later

**c** = STS Combination sprayer/ detasseler with the proportionate valve model year 2007 and later

### NOTE:

Make sure that the machine valve type is correctly selected to match the machine that the Tasseltron<sup>®</sup> control box is installed on. Refer to page 46 for more information on selecting machine valve type.

### NOTE:

Disconnect battery when servicing any part of electrical system to prevent system damage.

PROBLEM	POSSIBLE CAUSE	SUGGESTED REMEDY
No units will lift	Faulty "AUTO/MANUAL" switch Blown fuse Faulty #1 valve, coil, or loose coil mounting nut Loose wire connections Faulty wire connections Faulty main wire assembly	Replace control box Find short in wire, repair and replace fuse Tighten nut or replace coil Find loose connections, tighten Replace or repair Replace or repair
Only one unit will not lift	In "MANUAL" mode: faulty "UP/DOWN" switch Light photo sensor assembly Faulty valve, coil, or loose coil mounting unit Loose wire connections Lights of photo sensor not lined up with reflector Faulty row wire assembly Faulty sensor connector wire assembly	Replace control box Replace photo sensor Tighten nut or replace coil Find loose connections, tighten Line up sensor with reflector Replace or repair Replace or repair

# IX. TROUBLE SHOOTING

## HAGIE TASSELTRON<sup>®</sup>/LS SYSTEM – ELECTRICAL CONTINUED

PROBLEM	POSSIBLE CAUSE	SUGGESTED REMEDY
No units will lower	<p>Faulty "AUTO/MANUAL" switch</p> <p>Blown fuse</p> <p>Loose wire connections</p> <p>In "AUTO" mode: LS valve assembly unplugged</p>	<p>Replace control box</p> <p>Find short in wire, repair and replace fuse</p> <p>Find loose connections, tighten</p> <p>Plug in wire assembly</p>
Only one unit will not lower	<p>Faulty "UP/DOWN" switch</p> <p>In "AUTO" mode: faulty light sensor assembly</p> <p>Loose wire connections</p> <p>Faulty valve coil or loose coil mounting unit</p> <p>Faulty sensor connector wire assembly</p> <p>In "AUTO" mode: light sensor not lined up with reflector</p> <p>Faulty row LS wire assembly</p>	<p>Replace control box</p> <p>Replace sensor</p> <p>Find loose connections, tighten</p> <p>Tighten nut or replace coil</p> <p>Replace or repair</p> <p>Line up sensor with reflector</p> <p>Replace or repair</p>
No units will hold position	<p>In "AUTO" mode: no crop moving under sensor assemblies</p>	<p>Drive forward or select "MANUAL" mode</p>
In "AUTO" mode, wrong unit raises from sensor assembly	<p>Row LS wire assembly plugged into wrong sensor connector</p>	<p>Plug correct wire assembly into proper row sensor connector assembly</p>

# IX. TROUBLE SHOOTING

## G. HAGIE TASSELTROL® DISPLAY TROUBLESHOOTING

To gain further information on the status of the Tasselrol®/LS system before operation: while sitting in the operator's seat, turn the ignition key to the "ON" position (do not start the engine); turn the Tasselrol® box to the "ON" position; turn the "AUTO/MANUAL" switch to "MANUAL."

Make sure there is nothing physically blocking any upper or lower sensor's path to its reflector.

The display will show the status of the upper and lower photo sensor on each lift assembly. If the display shows a box ("□") in all upper and lower areas, the unit is ready for operation. If the display shows a corn stalk ("ŷ") in one or more areas, refer to pages 116-124 for further suggested remedies.

The LEFT-CENTER sensors are used as examples.

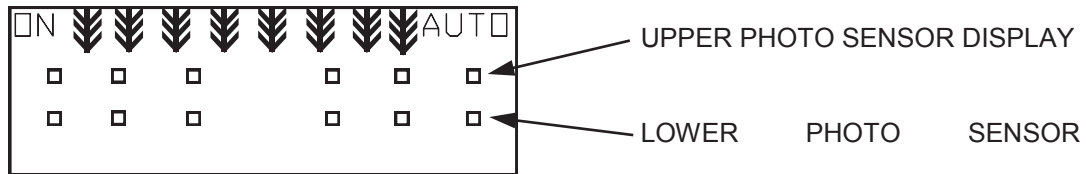

### TASSELTROL® DISPLAY

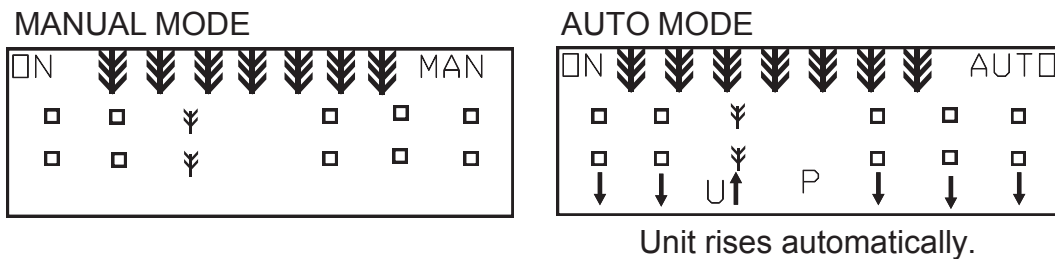

PHOTO SENSOR STATUS LIGHTS	POSSIBLE CAUSE
Lights at both photo sensors	Photo sensors not in line with reflector, call Hagie Manufacturing Customer Service.
No lights at either photo sensor	Faulty connector cable (See page 124, fig. 9.1, item 2)  Faulty RED and/or BLACK wire in connector cable (See page 124, fig. 9.1, item 1)

# IX. TROUBLE SHOOTING

## HAGIE TASSELTROL®/LS SYSTEM – DISPLAY CONTINUED

### TASSELTROL® DISPLAY

MANUAL MODE

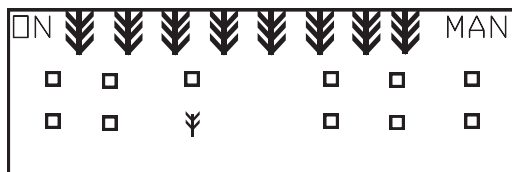

AUTO MODE

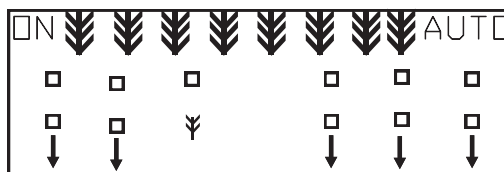

Unit does NOT rise automatically.

PHOTO SENSOR STATUS LIGHTS	POSSIBLE CAUSE
Lights at lower photo sensor	<p>Faulty GREEN wire in connector cable (See page 124, fig. 9.1, item 2)</p> <p>Photo sensor not in line with reflector, call Hagie Manufacturing Customer Service.</p> <p>Faulty BLUE wire in sensor assembly (See page 124, fig. 9.1, item 1)</p>
No lights at lower photo sensor	<p>Faulty RED and/or BLACK wire in connector cable (See page 124, fig. 9.1, item 2)</p>

# IX. TROUBLE SHOOTING

## HAGIE TASSELTRON<sup>®</sup>/LS SYSTEM – DISPLAY CONTINUED

### TASSELTRON<sup>®</sup> DISPLAY

MANUAL MODE

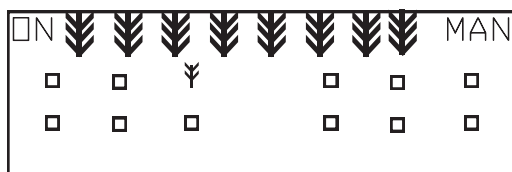

AUTO MODE

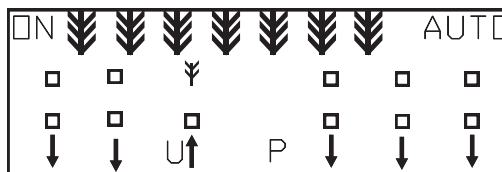

Unit rises automatically.

PHOTO SENSOR STATUS LIGHTS	POSSIBLE CAUSE
Lights at upper photo sensor	Faulty WHITE wire in sensor assembly (See page 124, fig. 9.1, item 1)  Faulty BLUE wire in sensor assembly (See page 124, fig. 9.1, item 1)
No lights at upper photo sensor	Faulty RED and/or BLACK wire in connector cable (See page 124, fig. 9.1, item 2)

# IX. TROUBLE SHOOTING

## TASSELTROL® WIRE DIAGRAM

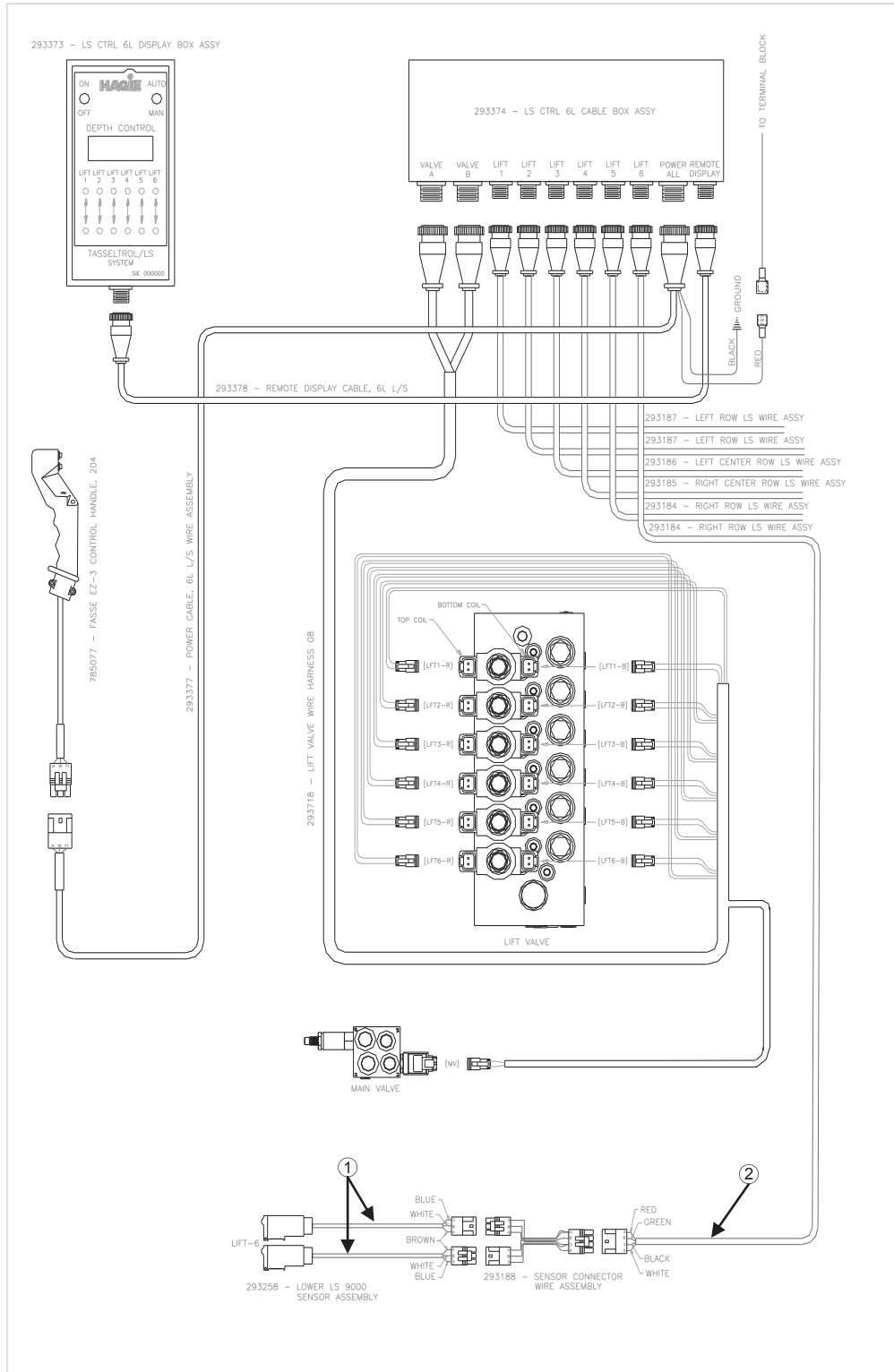

FIG 9.1

# IX. TROUBLE SHOOTING

---

NOTES



# X. LIMITED WARRANTY

## 1. The Warranty

- a. This warranty gives you specific legal rights. You may also have other rights which may vary from state to state.
- b. Hagie makes this warranty only to the original purchaser of its new equipment.
- c. The warranty period ends 12 months from the date of delivery of equipment to the original purchaser. When requesting warranty service, the original purchaser must present evidence of the date of delivery of the equipment.
- d. Parts or rebuilt assemblies furnished under the terms of this warranty are not warranted beyond the original warranty period.
- e. Exceptions to this warranty must be covered by separate warranty agreements.

## 2. Items not covered by Hagie Warranty

- a. Used equipment.
- b. Tires, tubes, engines, and batteries (under separate manufacturer's warranty).
- c. Depreciation or damage caused by normal wear, accident, improper maintenance, improper storage, or improper use.
- d. Service calls and transporting the equipment to and from the place where the warranty work is performed.

## 3. Unapproved service or modification

### NOTE:

All obligations of Hagie Manufacturing Company under this warranty shall be terminated if:

- a. . . . service is performed by someone other than Hagie authorized personnel.  
or
- b. . . . the equipment is modified or altered without Hagie approval.

## 4. No commercial loss coverage

- a. Hagie shall not be liable for incidental or consequential damages or injuries (damage and repairs of equipment itself, loss of profits, rental or substitute equipment, loss of good will, etc.).
- b. SOME STATES DO NOT ALLOW THE EXCLUSION OR LIMITATION OF INCIDENTAL OR CONSEQUENTIAL DAMAGES, SO THE ABOVE LIMITATION MAY NOT APPLY TO YOU.

## 5. Merger clause

- a. The entire warranty agreement is included in this writing.
- b. Any oral agreements that are made by the selling persons about the equipment are not warranties, and are not to be relied upon by the purchaser.

## 6. No representations or implied warranty

- a. The parties agree that the implied warranties of merchantability and fitness for a particular purpose and all other warranties expressed or implied, are excluded from this transaction and shall not apply to the equipment sold.

# INDEX

	PAGE		PAGE
<b>A</b>			
<b>Adjusting</b>		<b>Cutter Heads</b>	
Cab Climate Controls.....	78	Attaching .....	38-40
Detasseling Depth.....	68	Operating.....	52
Toe-In.....	112		
Tread Width.....	30-31	<b>D</b>	
<b>Air Conditioning System</b>		<b>Daily Inspection</b> .....	114
Belt.....	107	<b>Depth Command</b>	
Cab Filters.....	100	Attaching .....	41
Charging System.....	94	Fuse.....	105
Climate Controls.....	78	Operating.....	68
Dryer.....	98	<b>Detasseling Heads</b> .....	36-40
Vents.....	78	<b>Dimensions</b> .....	23
<b>Antifreeze</b> .....	96-97	<b>Display, Tasselrol®</b> .....	65-66
<b>Attaching</b>		Trouble Shooting.....	129-131
Cutter Heads.....	38-40	<b>Drive Train</b>	
Depth Command.....	41	Specifications.....	25
Lift Arm Assemblies .....	35	Maintenance	
LS System.....	41	Hydrostatic Pump.....	108
Outrigger Options.....	34	Auxiliary Gear Pumps.....	108
Quad Pullers.....	36-37	Wheel Motors.....	108
<b>Auxiliary Hydraulic Gear Pumps</b> .....	49	Torque Hubs®.....	108
<b>B</b>			
<b>Battery</b>		<b>Driving Instruction</b> .....	81-82
Charging.....	103	<b>Driving Safety</b> .....	4
Cleaning.....	103	<b>Dump Valve</b> .....	50-51
Disconnect Switch.....	42	<b>Dwell</b> .....	55
Replacement.....	103		
Storage.....	115	<b>E</b>	
<b>Belts</b> .....	107	<b>Electrical System.</b> .....	103-106
<b>Bolt Torque Values</b>		Specifications.....	26
Leg Mounting Bolts.....	110	Trouble Shooting.....	123
Wheel Lug Nuts.....	109	Tasselrol®.....	127-128
<b>Bottom Parameter, Tasselrol®</b> .....	61	<b>Electro-Hydraulic Valve</b> .....	50-51
<b>C</b>			
<b>Cab</b>		<b>Emergency Exit, Cab</b> .....	77
Climate Controls.....	78	<b>Emergency Stop, Cab</b> .....	77
Emergency Exit.....	77	<b>Engine</b>	
Filters.....	100	Belt.....	107
Interior Lights .....	80	Starting/ Operating.....	42-43
Radio .....	80	Fuel	
Seat Operation .....	79	Filters.....	99
Windshield Wiper .....	80	Type.....	93
<b>Cantrak</b> .....	69-71	Oil.....	90
<b>Charcoal Filter, Cab</b> .....	100	Specifications.....	24
<b>Charge Pressure</b> .....	46	Trouble Shooting.....	117-118
<b>Charge Pressure Filter, Hydraulic</b> .....	97	<b>Engine Oil Pressure Gauge</b> .....	69
<b>Circuit Breakers</b>		<b>F</b>	
Control Panel.....	104	<b>Filter Minder®</b> .....	69, 96
Wire Harnesses.....	104	<b>Filters</b>	
<b>Climate Controls, Cab</b> .....	78	Air Conditioning Dryer.....	98
<b>Cooling System</b>		Cab.....	100
Coolant.....	92-93	Engine Air Intake Filter.....	97
Radiator Grille Screens.....	95	Fuel Filters.....	99
		Hydraulic Charge Pressure Filter.....	96
		Hydraulic High-Pressure In-Line Filter.....	98
		Hydraulic Return Filter.....	97

# INDEX

	PAGE		PAGE
Hydraulic Suction Filter.....	97	<b>blies.....</b>	35
Radiator Grille Screen.....	100	<b>Lift Cylinders.....</b>	51
<b>Fresh Air Intake Filter, Cab.....</b>	<b>100</b>	<b>Lift Arm Valves.....</b>	<b>52</b>
<b>Fluid Capacities.....</b>	<b>94</b>	<b>Lift points, machine.....</b>	<b>140</b>
<b>Fluids</b>		<b>Lights</b>	
Air Conditioning Charge.....	94	Beacon.....	41
Cooling System Coolant.....	92-93	Halogen Work Lights.....	74
Engine Oil.....	90	Hazard/Warning Lights.....	75
Fuel.....	93	Interior Lights, Cab.....	80
Hydraulic Oil.....	90	Running Lights.....	75
Torque Hub® Oil.....	91	Turn Signal.....	75
<b>Fuel</b>		<b>Light Sensing (LS) System</b>	
Filters.....	99	Attaching.....	41
Gauge.....	69	Operating.....	67
Maintenance.....	93	<b>Loop Flushing Valve.....</b>	<b>46</b>
Safety.....	6	<b>Lubrication</b>	
Tank Selector Switch.....	73	Leg Bearings.....	101
Type.....	93	Quad Puller.....	102
<b>Fuses</b>		Torque Hub® Seal Boots.....	102
Control Panel.....	104	<b>Lug Nuts.....</b>	<b>109</b>
Depth Command.....	105		
		<b>M</b>	
		<b>Machine Valve Type.....</b>	<b>54</b>
<b>Gauges.....</b>	<b>69</b>	<b>Maintenance Safety.....</b>	<b>6</b>
		<b>Maintenance Schedule.....</b>	<b>86</b>
<b>H</b>		<b>Motor Control Valve.....</b>	<b>52</b>
<b>Handrail, removable.....</b>	<b>137</b>	<b>Multifunction Valves.....</b>	<b>46</b>
<b>High Pressure In-Line Filter.....</b>	<b>98</b>		
<b>Hour Meter.....</b>	<b>69</b>	<b>O</b>	
<b>Hydraulic Oil Reservoir.....</b>	<b>90</b>	<b>Operating Information.....</b>	<b>42-80</b>
<b>Hydraulic System.....</b>	<b>49-52</b>	<b>Oil Pressure Gauge, Engine.....</b>	<b>69</b>
Trouble Shooting.....	121-122	<b>Operating Safety.....</b>	<b>5</b>
Tasseltrol®.....	124-126	<b>Outrigger Assembly.....</b>	<b>34</b>
<b>Hydraulic Filters</b>		<b>Outrigger Fold Option</b>	
Charge Pressure.....	97	Manual.....	82
Return.....	97	Hydraulic.....	82
Suction.....	97		
<b>Hydraulic Fold Option.....</b>	<b>82</b>	<b>P</b>	
<b>Hydraulic Safety.....</b>	<b>6</b>	<b>Parameter Mode.....</b>	<b>53</b>
<b>Hydrostatic Drive System.....</b>	<b>45-48</b>	<b>Parking Brake.....</b>	<b>48</b>
Charge Pressure.....	46	<b>Power Steering</b>	
Operation.....	46	Cylinders.....	50
Pump		Motor.....	50
Neutral Setting.....	108	<b>Prepare to Operate.....</b>	<b>30-41</b>
Service.....	108	<b>Preoperational Checks.....</b>	<b>42</b>
Trouble Shooting.....	119-120	<b>Programming</b>	
Valves.....	46-47	Tasseltrol®.....	53-66
		<b>Pumps</b>	
<b>I</b>		Auxiliary Gear Pumps.....	49
<b>Instrument Panel Gauges.....</b>	<b>72</b>	Hydrostatic.....	44
<b>Interior Lighting (cab).....</b>	<b>80</b>		
		<b>Q</b>	
<b>L</b>		<b>Quad Pullers</b>	
<b>Leg Bearings.....</b>	<b>101</b>	Attaching.....	36-37
<b>Leg Mounting Bolts.....</b>	<b>110</b>	Lubrication.....	102
<b>Lifts.....</b>	<b>55</b>	Operating.....	52
<b>Lift</b>			
<b>Arm</b>		<b>R</b>	
<b>Assem-</b>		<b>Radiator Grille Screens.....</b>	<b>95</b>

# INDEX

	PAGE		PAGE
Radio.....	80	Quick Reference.....	65-66
Recirculating Filter (cab).....	100	Trouble Shooting	
Repair/Maintenance Safety.....	6	Display.....	129-131
Response Parameter, Tasselrol®.....	57	Electrical.....	119-120
Return Filter, Hydraulic.....	97	Hydraulic.....	121-126
<b>S</b>			
Safety.....	4-6	<b>Tires</b>	
Seat		Air Pressure.....	111
Comfort Controls		Filling.....	111
Cab.....	78	Mounting.....	111
Standard.....	72	Specifications.....	28
Seal Boot, Torque Hub®.....	103	<b>Toe-In</b>	
Serial Number Locations.....	21-22	Adjusting.....	112
Service Intervals.....	87-99	Measuring.....	32
Service/Maintenance.....	86-114	<b>Top Parameter, Tasselrol®.....</b>	<b>60</b>
Specifications.....	23-29	<b>Torque Hubs®</b>	
Speedometer.....	69	Core Exchange.....	108
Steering		Disengaging (towing).....	84
Column Tilt.....	73	Oil Level.....	91
Cylinders.....	50	Seal Boot Lubrication.....	101
Motor.....	50	<b>Torque Values</b>	
Toe-In.....	112	Leg Mounting Bolts.....	110
Storage.....	115-116	Wheel Bolts.....	109
Suction Filter, Hydraulic.....	97	<b>Tow Point.....</b>	<b>141</b>
Suspension.....	113	<b>Traction Valve.....</b>	<b>47</b>
Switches		<b>Transporting.....</b>	<b>81-85</b>
All-UP and Hold.....	64	Driving.....	81-82
Battery Disconnect.....	42	Towing.....	84-85
Brake.....	48	Trailing.....	83-84
Depth Command.....	105	<b>Tread Width.....</b>	<b>30-31</b>
Fuel Selector.....	73	<b>Trouble Shooting Guide.....</b>	<b>117-132</b>
Hydraulic Fold (if equipped).....	82	<b>Turn Signals.....</b>	<b>75</b>
Hydraulic Motor Control Valve.....	52	<b>U</b>	
Lights		<b>Up Offset.....</b>	<b>57</b>
Hazard/warning.....	75	<b>Up Speeds.....</b>	<b>57</b>
Running.....	75	<b>V</b>	
Turn signal.....	75	<b>Valve Compensation.....</b>	<b>55</b>
Work.....	74	<b>W</b>	
Shift.....	47	<b>Warning Decal Location.....</b>	<b>7-12</b>
Tasselrol®		<b>Warning Symbol Definitions.....</b>	<b>2</b>
Auto.....	53	<b>Warranty.....</b>	<b>142</b>
Lift(s).....	54	<b>Wheel Bolts.....</b>	<b>109</b>
Manual.....	53	<b>Wheel Motors.....</b>	<b>47</b>
Traction Valve.....	47	<b>Windshield Wiper.....</b>	<b>80</b>
Windshield Wiper (cab).....	80	<b>Winter Storage Directions.....</b>	<b>115-116</b>
<b>T</b>			
Table of Contents.....	3		
Tachometer.....	69		
Tasselrol®			
Operating.....	62-67		
Programming			
Bottom Parameter.....	61		
Response Parameter.....	59		
Top Parameter.....	60		