

HAGIE
UpFront
204SP



**PARTS MANUAL
FOR
HAGIE MODEL 204SP DETASSELLER**

HAGIE MANUFACTURING COMPANY

721 CENTRAL AVE WEST
BOX 273

CLARION, IOWA 50525-0273

COVERS MACHINE SERIAL NUMBERS: U1011121001 thru U1011121100
U1031121001 thru U1031121100
10-12 493488
02-15, 01-18

To obtain the most current parts manual for your machine, please visit www.hagie.com.

© 2012, 2015, 2018 Hagie Manufacturing Company. Clarion, Iowa USA

DETASSELER IDENTIFICATION

Each Hagie sprayer is identified by means of a frame serial number.

This serial number denotes the model, the year in which it was built, and the number of the sprayer. As for further identification, the engine has a serial number and the planetary hubs have identification plates that describe the type of mount and gear ratio. To insure prompt, efficient service when ordering parts or requesting service repairs from Hagie Manufacturing Company, record the serial and identification numbers in the space provided below.

NOTE: Reference to left hand and right hand used throughout this manual refers to the position when seated in the operator's seat facing forward.

This manual is not intended to be a complete guide for machine maintenance and repairs. If you are not properly trained to perform service on this machine, contact Hagie Customer Support for assistance. Improper maintenance or repair may result in property damage, personal injury, or death.

DETASSELER SERIAL NUMBER

ENGINE SERIAL NUMBER

PLANETARY HUB IDENTIFICATION NUMBERS

TABLE OF CONTENTS

ENGINE ASSEMBLIES	4-6
POSITRACTION VALVE.	7
HI-PRESS FILTER & LOOP FLUSHING VALVE	8-9
FLOW DIVIDER.	10-11
AIR CLEANER12
RADIATOR AND OIL COOLER13
LEG ASSEMBLIES.	14-17
TIRE18
BRAKE SOLENOID ASSEMBLY19
TIE ROD ASSEMBLY.20
STEERING CYLINDER ASSEMBLY.21
FUEL AND OIL TANKS.	22-23
LADDER AND SERVICE PLATFORM	24-25
BATTERY26
OPERATOR STATION ASSEMBLY	27-29
CONSOLE ASSEMBLY.	30-32
E-STOP SWITCH ASSEMBLY.33
CATRAK ASSEMBLY34
SHEET METAL	35-36
MOTOR CONTROL VALVE37
RETURN FILTER	38-39
ELECTROHYDRAULIC VALVE.40
DUMP VALVE.41
OUTRIGGER AND LIFT ASSEMBLY	42-59
LS SENSOR.60
QUAD AND CUTTER HEAD.	61-62
CUTTER CASE DRAIN FITTING ASSEMBLY.64
MALE ROW CHOPPER.	65-66
DEPTH COMMAND BOX	67-70
CAB OPTION.	71-76
CANOPY OPTION77
OUTRIGGER HYDRAULIC FOLD OPTION	78-79
WEIGHT BRACKET OPTION80
DECALS.	82-83
WIRING DIAGRAM.84-101
HYDRAULIC SCHEMATIC	102-143
ABBREVIATIONS	144
INDEX	145

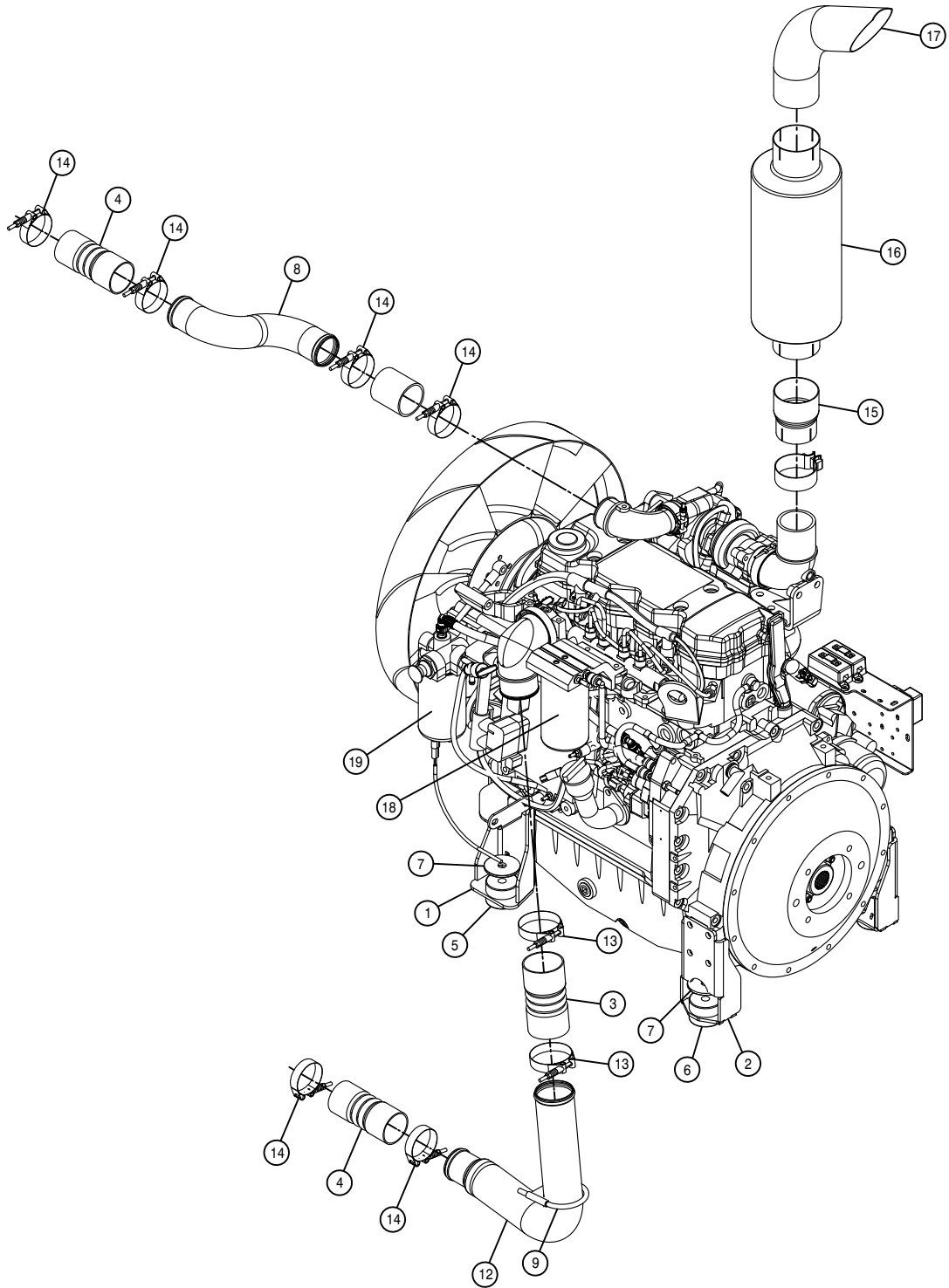

ENGINE ASSEMBLY

DET.	QTY	PART NO.	DESCRIPTION
1	1	316863	LH FRT ENG MT, MFM66-A
2	1	316865	LH REAR ENG MT, MRM103-A
3	1	311579	CAC HOSE, 3"
4	2	311584	2.50 X 6.00 CAC HOSE
5	1	311093	RUBBER MT, 360LB LOAD 60272-2
6	1	311094	RUBBER MT, 860LB LOAD 60272-4
7	2	311095	SNUBBING WASH FOR 311093/094
8	1	311586	CAC TUBE, HOT
9	1	311587	CAC TUBE, COLD
10	1	316853	CUMM ENG KIT, T3(OPSTN)204SP' 10
11	1	316855	CUMM ENG KIT, T3(CAB) 204SP' 10
12	1	470475	3" EXHAUST CLAMP
13	2	520146	3.06/3.38 T-BOLT HOSE CLAMP SS
14	6	520153	3.00 T-BOLT HOSE CLAMP (SPRNG)
15	1	311589	EXHAUST PIPE ADPTR
16	1	311590	MUFFLER
17	1	311591	EXH PIPE STACK
18	1	316683	FUEL FILTER, ENG, TIER 3 07
19	1	316684	FILTER, PRE FUEL 25 MICRON

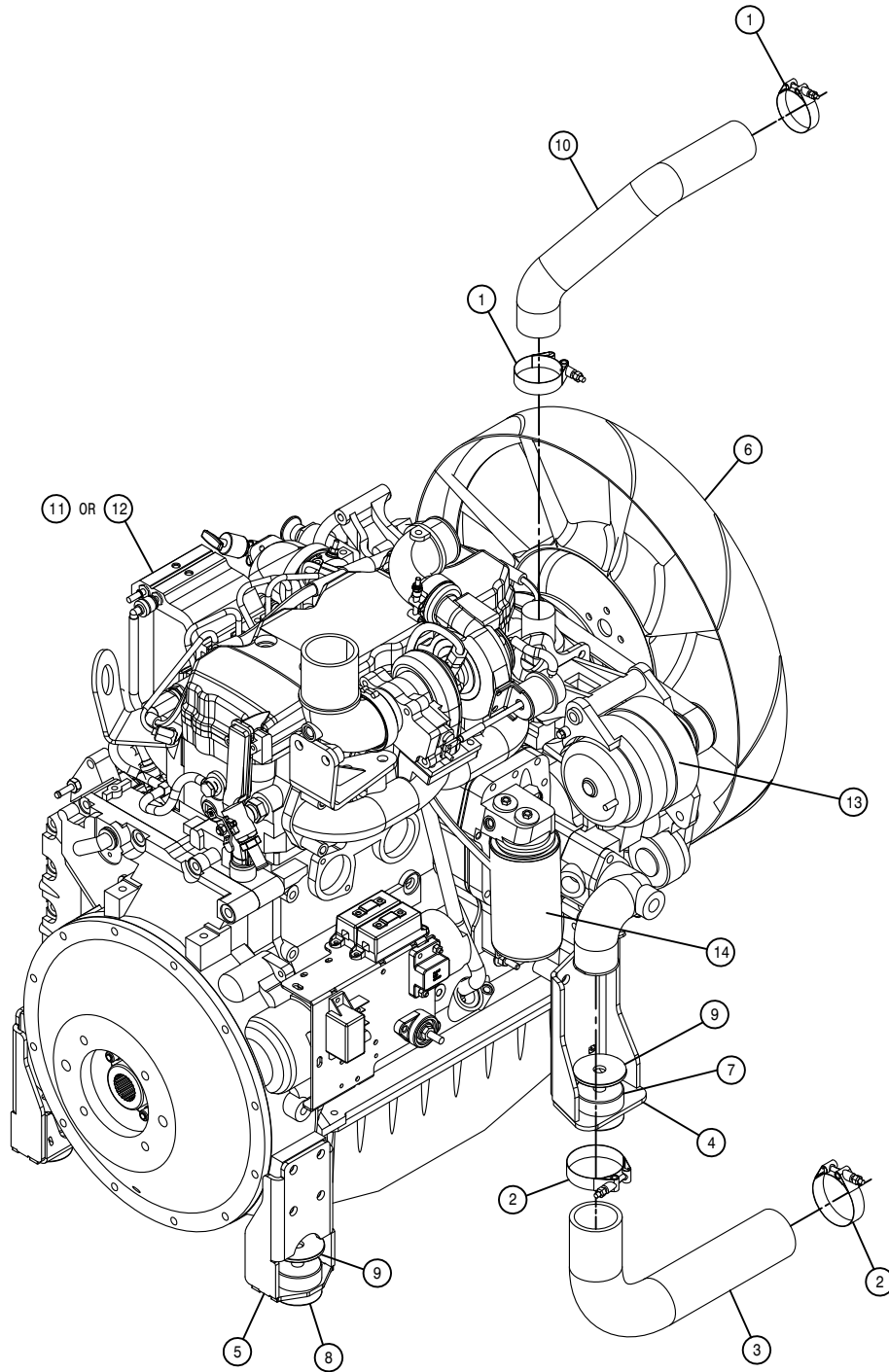

ENGINE ASSEMBLY

DET. QTY PART NO. DESCRIPTION

1	2	520141	2.31/2.62 T-BOLT HOSE CLAMP SS
2	2	520143	2.87/3.18 T-BOLT HOSE CLAMP SS
3	1	311097	LOWER RAD HOSER,MCA189-B
4	1	316862	RH FRT ENG MT, MFM67-A
5	1	316864	RH REAR ENG MT, MRM104-A
6	1	316551	FAN, 24" CUMM QSB205, 2101 03
7	1	311093	RUBBER MT, 360LB LOAD 60272-2
8	1	311094	RUBBER MT, 860LB LOAD 60272-4
9	2	311095	SNUBBING WASH FOR 311093/094
10	1	311583	UPPER RAD HOSE ,MCA195-A
11	1	316853	CUMM ENG KIT,T3(OPSTN)204SP'10
12	1	316855	CUMM ENG KIT,T3(CAB) 204SP'10
13	1	316391	DELCO ALTERNATOR,130 AMP 24SI
14	1	316372	LUBE FILTER (CUMM ENG 316360)

HYDROSTATIC PUMP ASSEMBLY

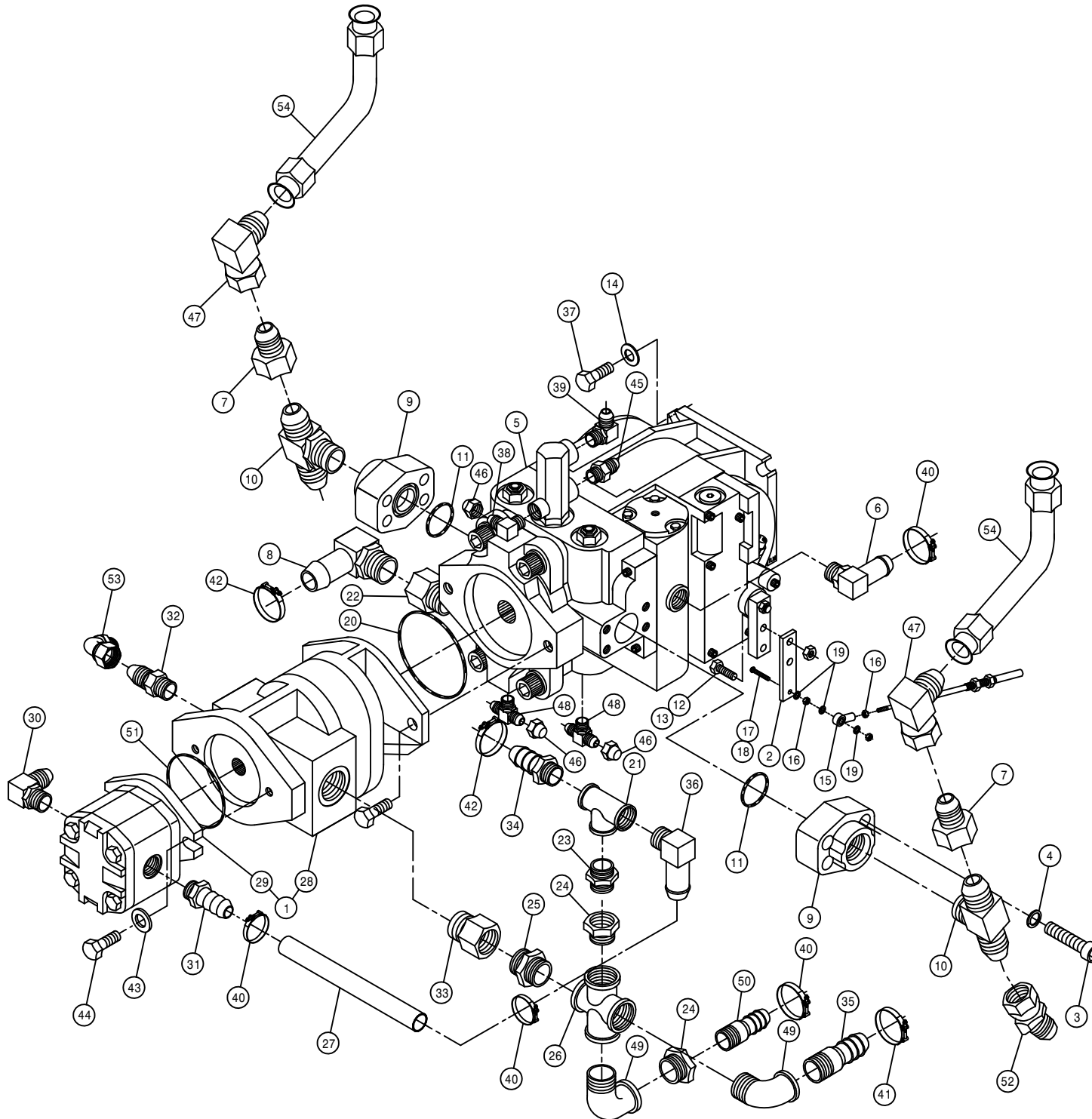

DET.	QTY	PART NO.	DESCRIPTION
1	1	606352	TANDEM PUMP,606353 & 606929
2	1	316160	PUMP CONT LEVER EXT 280 CUMM
3	8	470188	7/16-14 X 1 3/4 SKTHD CAP SCR
4	8	470189	7/16 HC LOCK WASH FOR 618598
5	1	607572	SUND 100CC PUMP,23T B-MT /FILT
6	1	618118	3/4 HOSE BARB-90-1 1/16MOR
7	2	618541	1 5/16FJIC-1 1/16MJIC ADPTR
8	1	618638	1IN HOSE BARB-45-1 5/16MOR
9	2	618598	1" 4-BOLT FLG X 1 5/16 FOR
10	2	618599	1 5/16MOR BRANCH TEE-1 5/16MJ
11	2	870219	BUNA ORING 1 5/16 X 1 9/16 90D
12	2	900003	1/4UNC X 1" HEX BOLT
13	2	914000	1/4UNC HEX STOVER NUT
14	4	920004	1/2 SAE FLAT WASHER
15	1	473921	BALL JOINT NO 10-32 THD
16	2	910027	10-32 HEX NUT
17	1	903893	10-32 X 1" PHIL PAN MACH SCR
18	1	914027	10-32 HEX STOVER NUT
19	3	920510	#10 LOCK WASHER
20	1	606357	O-RING,3.737ID-.103CS-3.94 BMT
21	1	505101	BLK PIPE TEE 1.00NPT
22	1	618639	1 5/8MOR-1 5/16FOR ADPTR
23	1	505105	1MNPT HEX PIPE NIPPLE STL
24	2	506005	1 1/4 TO 1 RED BUSH BLK MAL
25	1	507026	1 1/4MNPT HEX PIPE NIPPLE STL
26	1	506202	BLK PIPE CROSS 1.25NPT
27	1	601399	HOSE, 3/4 X 13 1FBR-1SPI
28	1	606353	GEAR PUMP,5.38CI SAUER
29	1	606929	SUND GEAR PUMP .66CI, SPLINED
30	1	611128	7/8MJIC-90-7/8MOR LBO
31	1	618075	3/4 HOSE BARB-1 1/16MOR
32	1	618472	1 5/8MJIC-1 5/8MOR ADPTR
33	1	618816	1 7/8MOR-1 1/4FNPT ADPTR
34	1	714560	1NPT X 1 HOSE BARB
35	1	715660	HOSE BARB 1 1/4NPT X 1 1/4
36	1	716000	3/4 HOSE BARB-90-1MNPT
37	4	900265	1/2UNC X 1 1/2 HEX BOLT
38	1	618119	9/16MJIC-90-9/16MOR LBO
39	1	618183	3/4MJIC-90-7/8MOR LBO
40	4	520154	1.06/1.19 T-BOLT HOSE CLAMP SS
41	1	520132	1.62/1.87 T-BOLT HOSE CLAMP SS
42	2	520138	1.38/1.56 T-BOLT HOSE CLAMP
43	2	920002	3/8 SAE FLAT WASHER
44	2	900130	3/8UNC X 1 1/4 SER FLANGE BOLT
45	1	618327	3/4MJIC-7/8MOR ADPTR
46	3	618531	9/16FJIC CAP NUT
47	2	618191	1 1/16MJ-90-1 1/16FJ SWIV LBO
48	2	618629	9/16MOR BRANCH TEE-9/16MJIC
49	2	506410	BLK PIPE ST EL 90DEG 1.25NPT
50	1	714331	1 NPT X 3/4 HOSE BARB
51	1	606924	O-RING FOR SUND A-MT
52	1	618630	1 5/16MJ-45-1 5/16FJ SWIV LBO
53	1	618851	1 5/8MJIC-90-1 5/8FJX TUBE FTG
54	2	614707	HYD TUBE ASSY,SUND,200 DIESEL

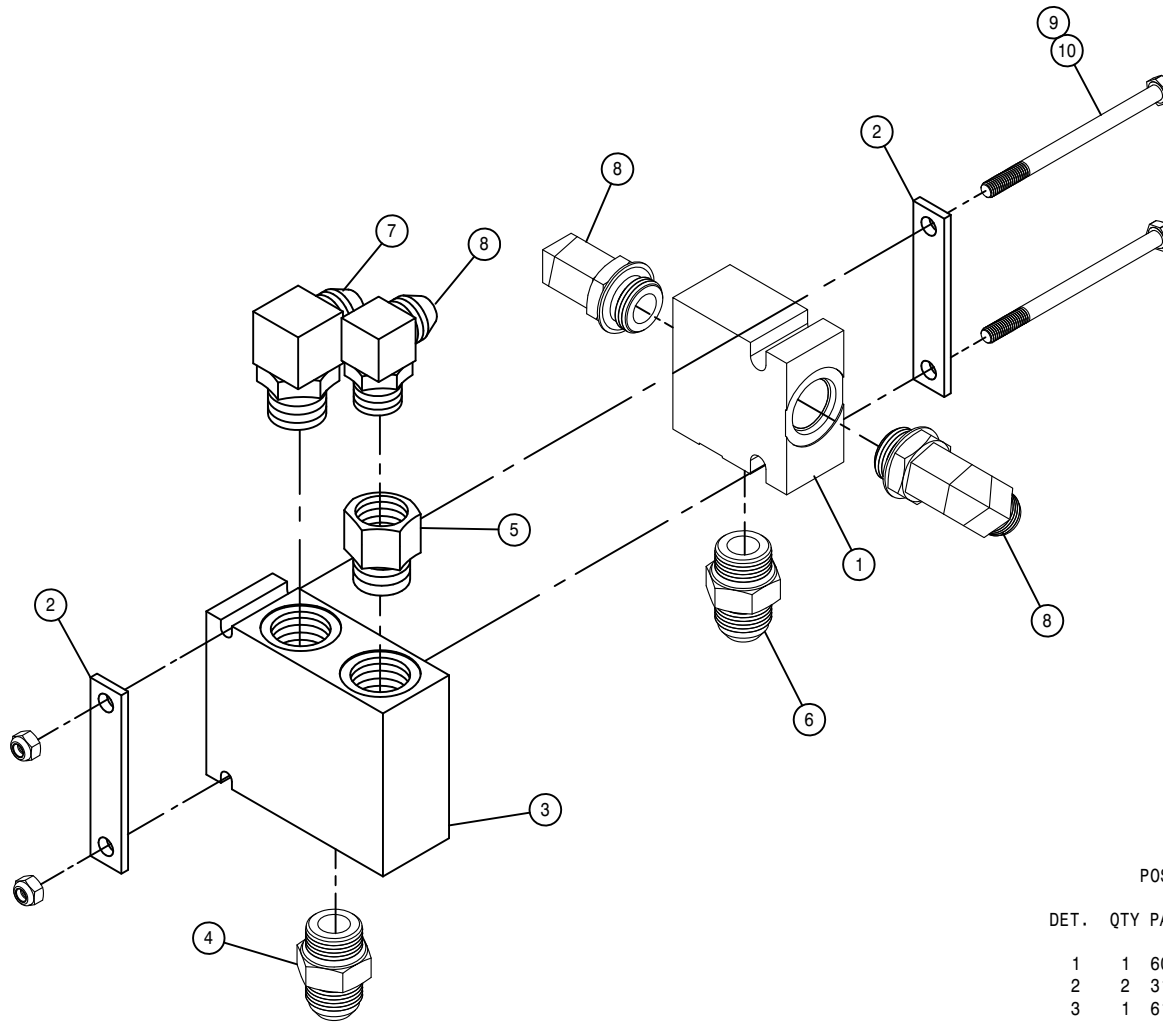

POSITRACTION VALVE ASSEMBLY

DET.	QTY	PART NO.	DESCRIPTION
1	1	606356	1 1/16FOR MANIFOLD,3 #12PORTS
2	2	314843	TEE KEEPER, TRAC VLV 200 89
3	1	610609	TRACTION VLV,STL,66S,40GPM
4	1	618308	1 1/16MJC-1 5/16MOR ADPTR
5	1	618312	1 5/16MOR-1 1/16FOR ADPTR
6	1	611127	1 1/16MJC-1 1/16MOR ADPTR
7	1	618589	7/8MJC-90-1 5/16MOR LBO
8	3	618535	7/8MJC-90-1 1/16MOR LBO
9	2	473001	5/16UNC HEX NUT,NYLOC 316 SS
10	2	900078	5/16UNC X 4 1/2 HEX BOLT

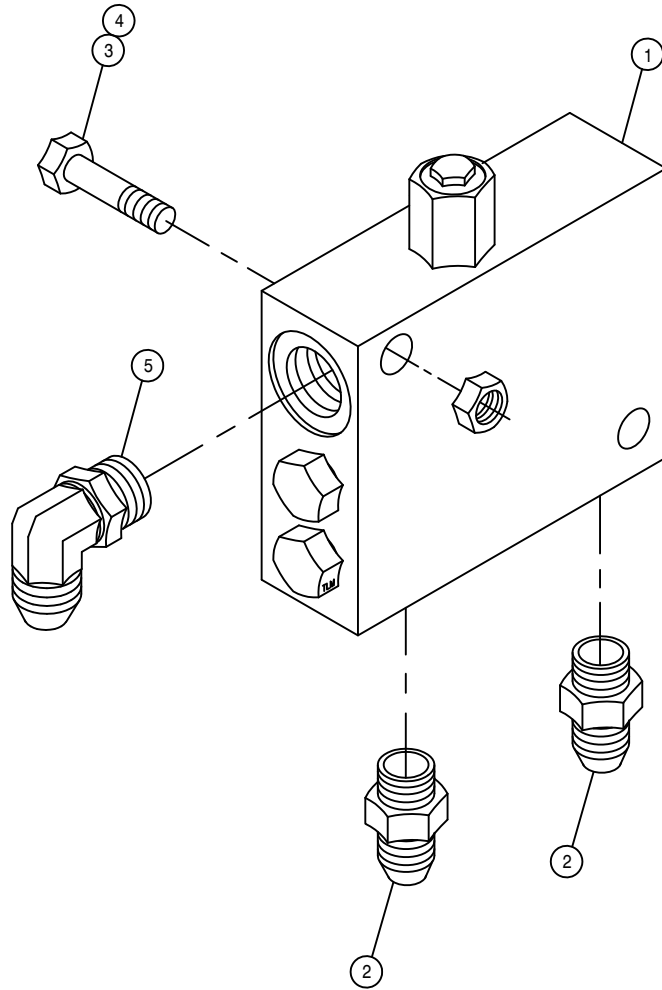

LOOP FLUSHING VALVE ASSEMBLY

DET. QTY PART NO. DESCRIPTION

1	1	610580	REMOTE FLUSHING VALVE, SUND
2	2	618126	9/16MJIC-9/16MOR ADPTR
3	2	900133	3/8UNC X 2" SERR FLANGE BOLT
4	2	914004	3/8UNC HEX STOVER NUT
5	1	618119	9/16MJIC-90-9/16MOR LBO

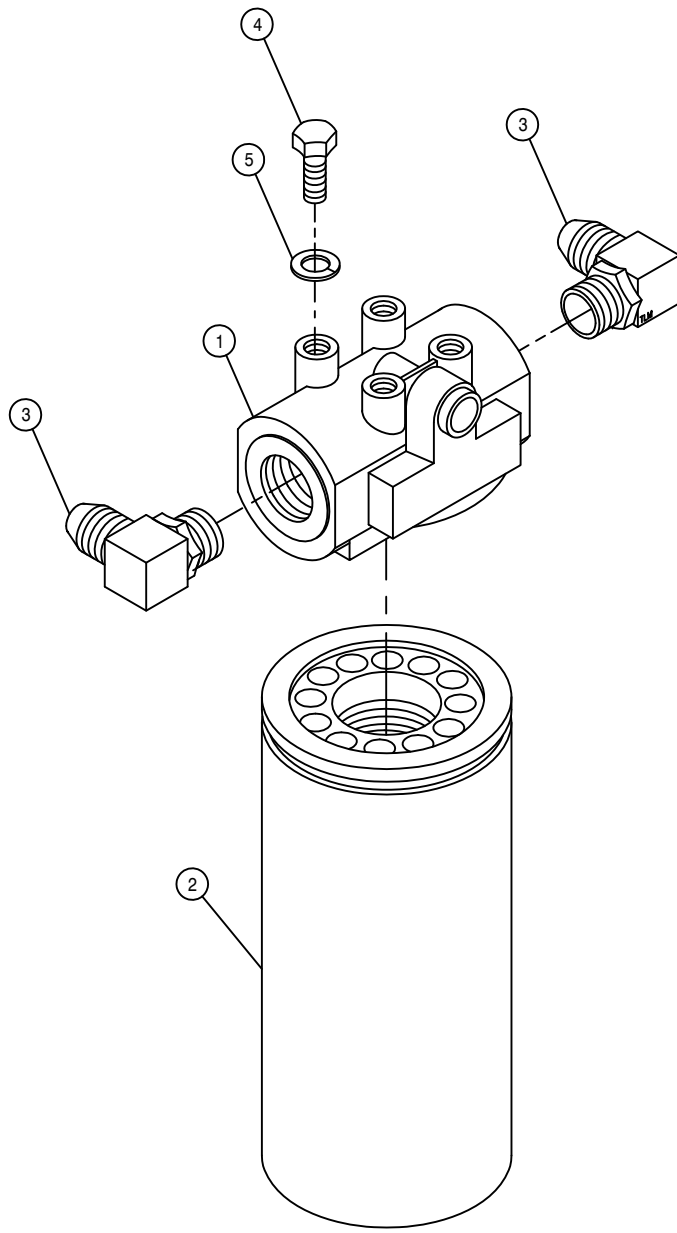

HI-PRESS FILTER ASSEMBLY

DET. QTY PART NO. DESCRIPTION

1	1	605608	HYD FILTER HEAD, DONALDSON
2	1	605609	HYD FILTER ELEMENT, DONALDSON
3	2	618474	3/4MJIC-90-1 1/16MOR LBO
4	4	900128	3/8UNC X 3/4 HEX BOLT
5	4	920502	3/8 LOCK WASHER

POSITRACTION VALVE ASSEMBLY

DET. QTY PART NO. DESCRIPTION

1	1	341849	POSITRACTION VALVE MT	200
2	1	920000	1/4 SAE FLAT WASHER	
3	1	606356	1 1/16FOR MANIFOLD,3 #12PORTS	
4	1	610586	POSITRACTION VLV,STL,88SP 60G	
5	1	343187	FRT RETURN MNFLD MT,204/SP 08	
6	2	618535	7/8MJIC-90-1 1/16MOR LBO	
7	2	618601	7/8MJIC-1 5/16MOR ADPTR	
8	1	618186	1 5/16MJIC-1 5/16MOR ADPTR	
9	1	618558	1 5/16MJIC-1 1/16MOR ADPTR	
10	2	900012	1/4UNC X 3 1/2 HEX BOLT	
11	1	900002	1/4UNC X 3/4 HEX BOLT	
12	3	914000	1/4UNC HEX STOVER NUT	
13	1	610593	O-RING FOR 610513	
14	1	610961	FLO DIV COMBINER,POSIVLV610586	
15	2	610022	COIL FOR 610586(SPADE CONNECT)	
16	2	900086	5/16UNC X 2 1/4 HEX BOLT	
17	2	470113	5/16UNC HEX FLANGE LOCK NUT	

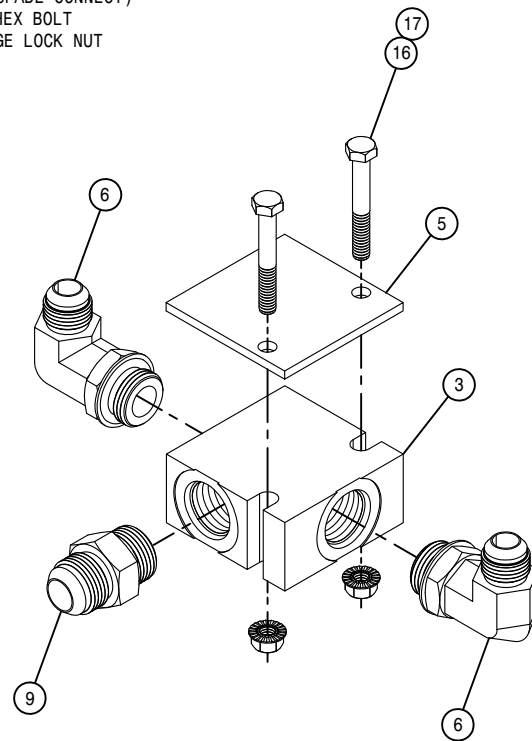
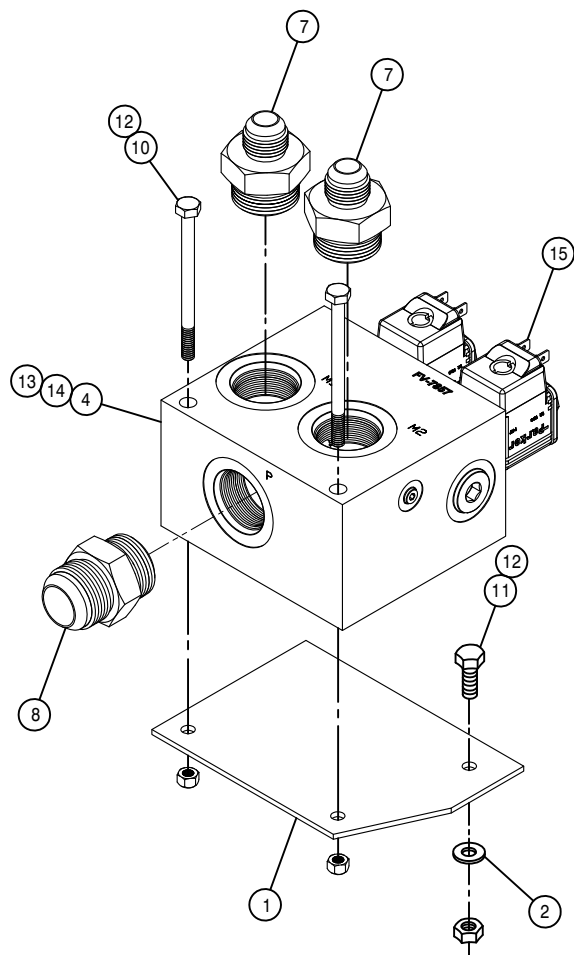

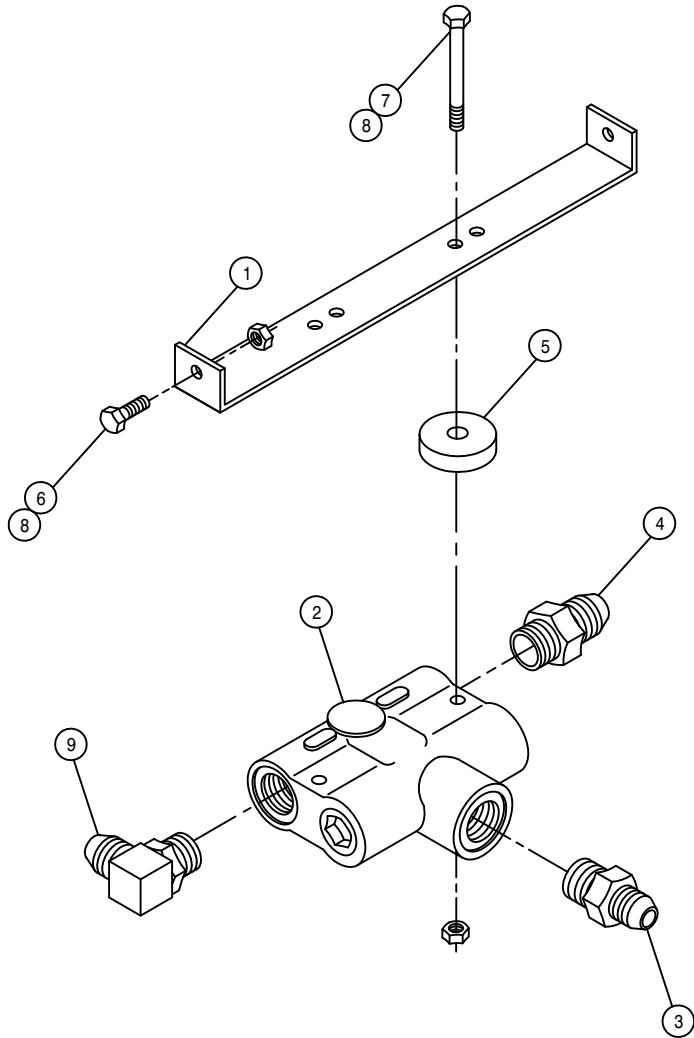

FLOW DIVIDER ASSEMBLY

DET. QTY PART NO. DESCRIPTION

DET.	QTY	PART NO.	DESCRIPTION	
1	1	341774	FLOW DIVIDER MT 280	89
2	1	607504	FLO DIV B50 2-8GPM 7/8 FOR	
3	1	611126	7/8MJIC-7/8MOR ADPTR	
4	1	618310	9/16MJIC-7/8MOR ADPTR	
5	2	748500	RUBER WASH 3/8X1/4IDX1 1/2 OD	
6	2	900002	1/4UNC X 3/4 HEX BOLT	
7	2	900009	1/4UNC X 2 3/4 HEX BOLT	
8	4	914000	1/4UNC HEX STOVER NUT	
9	1	618600	9/16MJIC-90-7/8MOR LBO	

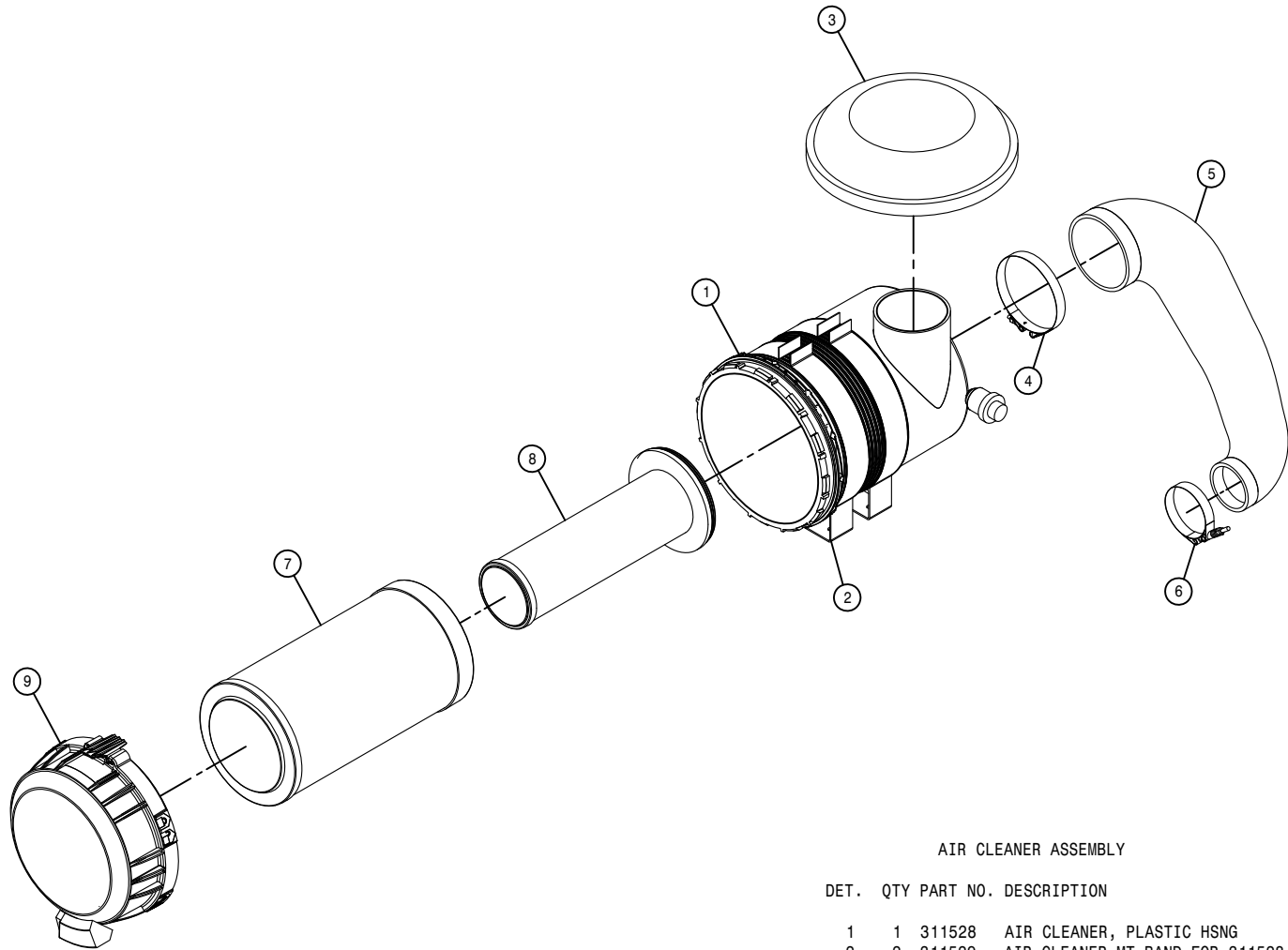

AIR CLEANER ASSEMBLY

DET.	QTY	PART NO.	DESCRIPTION
1	1	311528	AIR CLEANER, PLASTIC HSNQ
2	2	311529	AIR CLEANER MT BAND FOR 311528
3	1	311588	WEATHER HOOD,AIR CLEANER
4	1	520136	5.31/5.59 T-BOLT HOSE CLAMP SS
5	1	311585	AIR INTAKE HOSE, MOLDED
6	1	520130	3.31/3.59 T-BOLT HOSE CLAMP SS
7	1	311530	PRIMARY ELEMENT FOR 311528
8	1	311531	SAFETY ELEMENT FOR 311528
9	1	311548	COVER ASSEMBLY FOR 311528

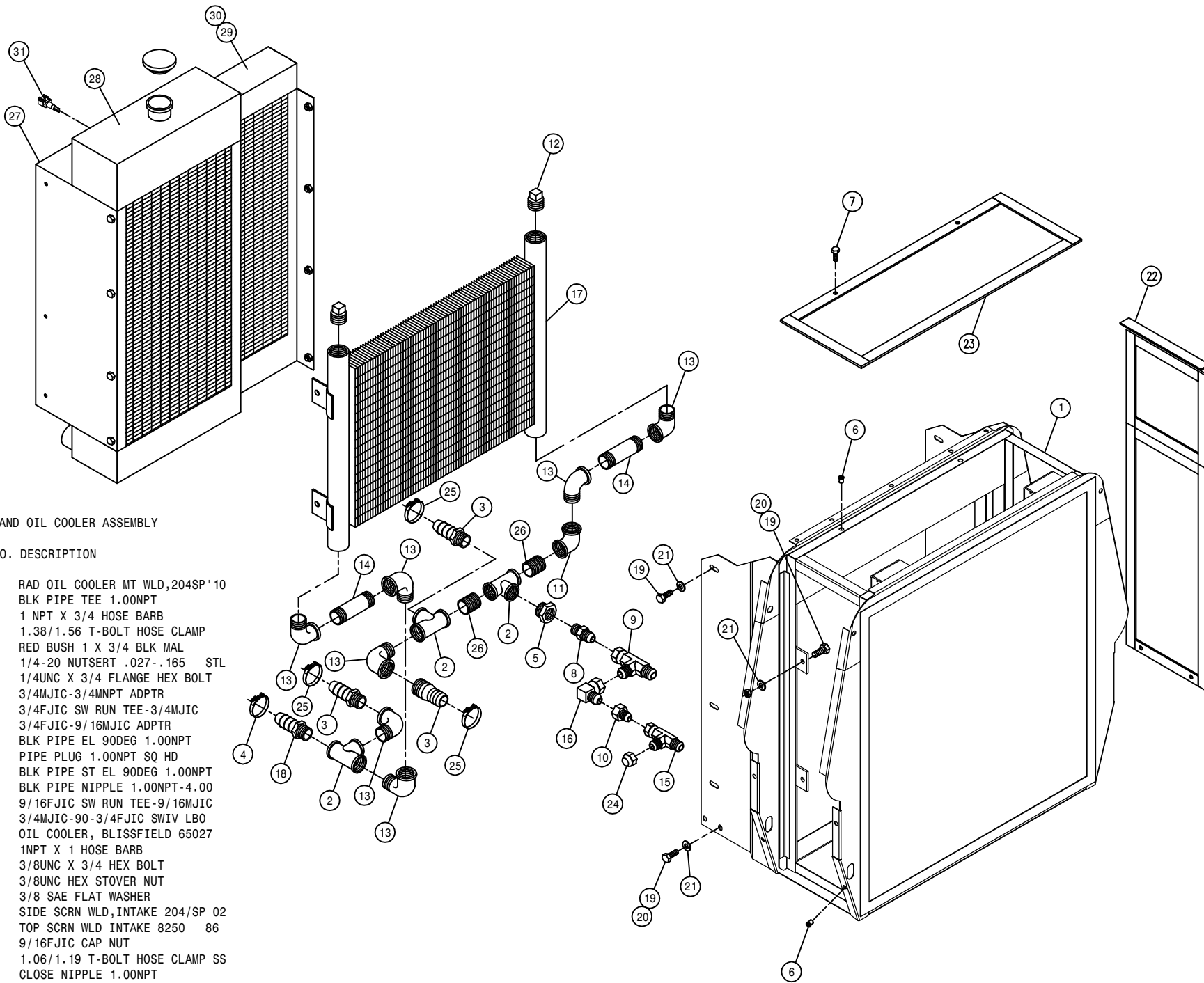

RADIATOR AND OIL COOLER ASSEMBLY

DET.	QTY	PART NO.	DESCRIPTION
	1	315091	RAD OIL COOLER MT WLD, 204SP '10
	2	3	505101 BLK PIPE TEE 1.00NPT
	3	3	714331 1 NPT X 3/4 HOSE BARB
	4	1	520138 1.38/1.56 T-BOLT HOSE CLAMP
	5	1	505213 RED BUSH 1 X 3/4 BLK MAL
	6	10	470380 1/4-20 NUTSERT .027-.165 STL
	7	2	470118 1/4UNC X 3/4 FLANGE HEX BOLT
	8	1	610300 3/4MJIC-3/4MNPT ADPTR
	9	1	618451 3/4FJIC SW RUN TEE-3/4MJIC
	10	1	618482 3/4FJIC-9/16MJIC ADPTR
	11	1	505300 BLK PIPE EL 90DEG 1.00NPT
	12	2	505102 PIPE PLUG 1.00NPT SQ HD
	13	7	505200 BLK PIPE ST EL 90DEG 1.00NPT
	14	2	505203 BLK PIPE NIPPLE 1.00NPT-4.00
	15	1	618486 9/16FJIC SW RUN TEE-9/16MJIC
	16	1	618609 3/4MJIC-90-3/4FJIC SWIV LBO
	17	1	618606 OIL COOLER, BLISSFIELD 65027
	18	1	714560 1NPT X 1 HOSE BARB
	19	12	900128 3/8UNC X 3/4 HEX BOLT
	20	8	914004 3/8UNC HEX STOVER NUT
	21	14	920002 3/8 SAE FLAT WASHER
	22	2	314988 SIDE SCRNL WLD, INTAKE 204/SP 02
	23	1	314495 TOP SCRNL WLD INTAKE 8250 86
	24	1	618531 9/16FJIC CAP NUT
	25	3	520154 1.06/1.19 T-BOLT HOSE CLAMP SS
	26	2	505201 CLOSE NIPPLE 1.00NPT
	27	1	315096 RAD, CAC, SHROUD KIT, 204SP '10
	28	1	315097 RADIATOR, 204SP '10
	29	1	315098 CHARGE AIR COOLER, 204SP '10
	30	1	315101 RAD SHROUD, 204SP (07-21521) '10
	31	1	291935 RAD WATER LEVEL SENSOR, T3 ENG

RIGHT FRONT LEG ASSEMBLY

DET. QTY PART NO. DESCRIPTION

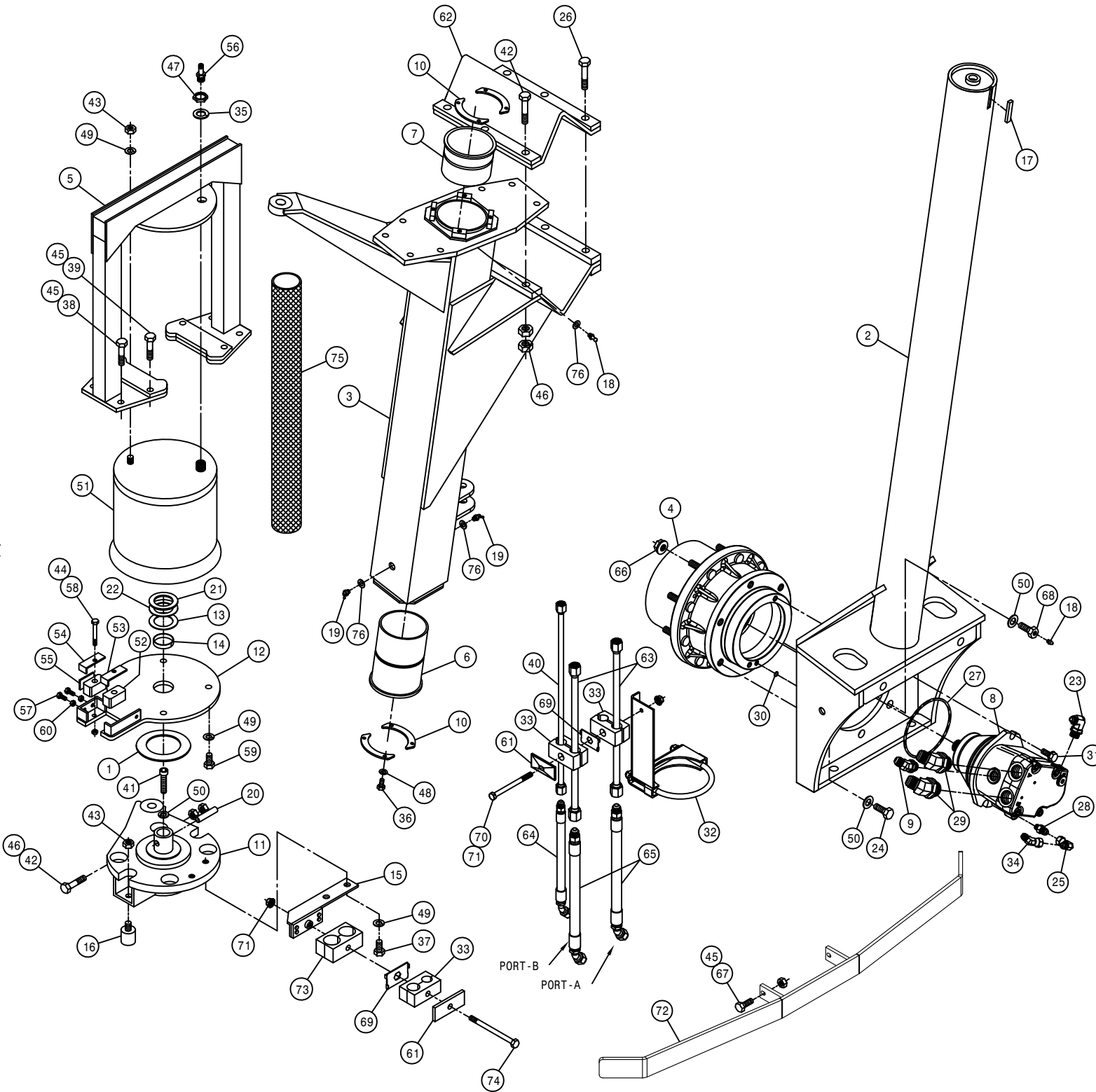

1	1	127505	THRUST BEARING, FIBERGLIDE
2	1	357942	FRT INNER LEG WLD, 204SP
3	1	357857	RH FRT OUTER LEG WLD, 204SP 01
4	1	610835	TORQ HUB, 24:1, 7HPA W/BRAKE
5	1	357864	AIR BAG ARCH WLD, RF/LR204SP 01
6	1	358564	FRT LEG LWR NYL SLEEVE 280 89
7	1	358565	FRT LEG UPR NYL SLEEVE 280 89
8	1	606193	SAUER WHL MOTOR, KC-38CC
9	1	618315	3/4MJIC-45-3/4MOR LBO
10	4	358927	LWR BRG KPR, LEG 98
11	1	358971	STEERING ARM WLD, RF/LR 2100 99
12	1	358980	AIR BAG MT WLD, RF/LR 2100 99
13	1	358994	LEG WASHER, NYLON 2100 99
14	1	358995	NYLON BEARING, LWR AB MT2100 99
15	1	357870	RH UPPER HOSE MT WELD, 204SP 01
16	2	470259	URETHANE BUMPER, 1.25D X 1.25L
17	1	470265	.250 X .375 CFFL X 1.88 C/L
18	2	471005	GREASE ZERK, 1/4 28 X 1/2
19	2	471023	GREASE ZERK 1/4-28 X 45
20	1	473906	ROLL PIN, 1/2 X 2 1/2 COILED
21	1	483061	WASH: 7GA X 1.66 X 2.50
22	1	483063	WASH: 14GA X 1.66 X 2.50
23	1	618119	9/16MJIC-90-9/16MOR LBO
24	5	900332	5/8UNC X 1 1/4 HEX BOLT
25	1	618618	9/16MJIC-90-9/16FJIC SWIV LBO
26	3	900837	5/8UNF X 3 1/2 HEX BOLT GR8
27	1	606197	O-RING, 4.737ID-.103CS-4.9430D
28	1	618304	9/16MJIC-7/16MOR ADPTR
29	2	618786	7/8MJIC-45-1 1/16MOR LBO
30	1	606198	O-RING, .239ID-.070CS-.3790D
31	2	900197	7/16UNC X 1 1/2 HEX BOLT
32	1	357946	RF/LR TUBE MT WLD, 204 07
33	3	470270	HOSE CLAMP BODY, .530-.680
34	1	618634	9/16MJIC-45-9/16FJIC SWIV LBO
35	1	920506	3/4 LOCK WASHER
36	8	900064	5/16UNC X 3/4 HEX BOLT
37	2	900263	1/2UNC X 1" HEX BOLT
38	4	900265	1/2UNC X 1 1/2 HEX BOLT
39	4	900267	1/2UNC X 2" HEX BOLT
40	1	615841	LEG CASE DRN TUBE ASSY, 204SP07
41	1	900390	5/8UNC X 2 1/2 SOCKET CAP SCR
42	4	900836	5/8UNF X 3 1/4 HEX BOLT GR8
43	3	910008	1/2UNC HEX NUT
44	2	914002	5/16UNC HEX STOVER NUT
45	10	914008	1/2UNC HEX STOVER NUT
46	14	914811	5/8UNF HEX NUT GR8
47	1	910013	3/4UNF HEX NUT
48	8	920501	5/16 LOCK WASHER
49	7	920504	1/2 LOCK WASHER
50	7	920505	5/8 LOCK WASHER
51	1	358831	AIRIDE SPRING 98
52	2	358990	NYLON GUIDE, 2100 LEG 99
53	1	358991	INNER KEEPER, NYL GUIDE, 2100 99
54	1	358992	OUTER KEEPER, NYL GUIDE, 2100 99
55	1	358993	.125 X 1.000 HRST X 1.68 C/L
56	1	470338	AIR TANK VALVE, 1/4MNPT W/CAP
57	2	900065	5/16UNC X 1" HEX BOLT
58	2	900069	5/16UNC X 2" HEX BOLT
59	4	900264	1/2UNC X 1 1/4 HEX BOLT
60	2	910002	5/16UNC HEX NUT
61	2	470276	CLAMP COVER PLATE, SNGL, 2.55LG
62	1	358759	LEG MT V-PLT WLD, 284T 94
63	2	615840	LEG HYD TUBE ASSY, 204SP 07
64	1	616432	08-381-08MJ-08FJX45-15 H/A
65	2	616433	10-381-10MJ-10FJX45-17 H/A
66	8	470140	5/8UNF SMTH FLANGE HEX NUT GR8
67	2	900266	1/2UNC X 1 3/4 HEX BOLT
68	1	610013	ZERK BOLT, 5/8 X 1 1/4 TORQ HUB
69	2	470281	STACK BOLT SAFETY LOCK PLATE
70	1	900075	5/16UNC X 3 3/4 HEX BOLT
71	2	470113	5/16UNC HEX FLANGE LOCK NUT
72	1	357950	STALK GUIDE WLD, 204 07
73	1	470343	TUBE CLAMP BODY, .875-.875
74	1	900075	5/16UNC X 3 3/4 HEX BOLT
75	1	342637	NYL HOSE SLEEVE, 2.96ID X 54.00
76	3	920000	1/4 SAE FLAT WASHER

LEFT FRONT LEG ASSEMBLY

DET. QTY PART NO. DESCRIPTION

DET.	QTY	PART NO.	DESCRIPTION
1	1	127505	THRUST BEARING, FIBERGLIDE
2	1	357942	FRT INNER LEG WLD, 204SP 07
3	1	357858	LH FRT OUTER LEG WLD, 204SP 01
4	2	900197	7/16UNC X 1 1/2 HEX BOLT
5	1	357865	AIR BAG ARCH WLD, LF/RR204SP 01
6	1	358564	FRT LEG LWR NYL SLEEVE 280 89
7	1	358565	FRT LEG UPR NYL SLEEVE 280 89
8	1	606197	O-RING, 4.737ID-.103CS-4.9430D
9	1	606198	O-RING, .239ID-.070CS-.3790D
10	4	358927	LWR BRG KPR, LEG 98
11	1	358972	STEERING ARM WLD, LF/RR 2100 99
12	1	358981	AIR BAG MT WLD, LF/RR 2100 99
13	1	358994	LEG WASHER, NYLON 2100 99
14	1	358995	NYLON BEARING, LWR AB MT2100 99
15	1	357871	LH UPPER HOSE MT WELD, 204SP 01
16	2	470259	URETHANE BUMPER, 1.25D X 1.25L
17	1	470265	.250 X .375 CFLL X 1.88 C/L
18	2	471005	GREASE ZERK, 1/4 28 X 1/2
19	2	471023	GREASE ZERK 1/4-28 X 45
20	1	473906	ROLL PIN, 1/2 X 2 1/2 COILED
21	1	483061	WASH: 7GA X 1.66 X 2.50
22	1	483063	WASH: 14GA X 1.66 X 2.50
23	1	610835	TORQ HUB, 24:1, 7HPA W/BRAKE
24	1	618119	9/16MJIC-90-9/16MOR LBO
25	1	618315	3/4MJIC-45-3/4MOR LBO
26	1	618618	9/16MJIC-90-9/16JIC SWIV LBO
27	3	470270	HOSE CLAMP BODY, .530-.680
28	1	618304	9/16MJIC-7/16MOR ADPTR
29	2	618786	7/8MJIC-45-1 1/16MOR LBO
30	3	900837	5/8UNF X 3 1/2 HEX BOLT GR8
31	2	470281	STACK BOLT SAFETY LOCK PLATE
32	1	357947	LF/RR TUBE MT WLD, 204
33	1	470343	TUBE CLAMP BODY, .875-.875
34	5	900332	5/8UNC X 1 1/4 HEX BOLT
35	8	470140	5/8UNF SMTH FLANGE HEX NUT GR8
36	8	900064	5/16UNC X 3/4 HEX BOLT
37	2	900263	1/2UNC X 1" HEX BOLT
38	4	900265	1/2UNC X 1 1/2 HEX BOLT
39	4	900267	1/2UNC X 2" HEX BOLT
40	1	615841	LEG CASE DRN TUBE ASSY, 204SP07
41	1	900390	5/8UNC X 2 1/2 SOCKET CAP SCR
42	4	900836	5/8UNF X 3 1/4 HEX BOLT GR8
43	3	910008	1/2UNC HEX NUT
44	1	920506	3/4 LOCK WASHER
45	10	914008	1/2UNC HEX STOVER NUT
46	14	914811	5/8UNF HEX NUT GR8
47	2	914002	5/16UNC HEX STOVER NUT
48	8	920501	5/16 LOCK WASHER
49	7	920504	1/2 LOCK WASHER
50	7	920505	5/8 LOCK WASHER
51	1	358831	AIRIDE SPRING 98
52	2	358990	NYLON GUIDE, 2100 LEG 99
53	1	358991	INNER KEEPER, NYL GUIDE, 2100 99
54	1	358992	OUTER KEEPER, NYL GUIDE, 2100 99
55	1	358993	.125 X 1.000 HRST X 1.68 C/L
56	1	470338	AIR TANK VALVE, 1/4MNPT W/CAP
57	2	900065	5/16UNC X 1" HEX BOLT
58	2	900069	5/16UNC X 2" HEX BOLT
59	4	900264	1/2UNC X 1 1/4 HEX BOLT
60	2	910002	5/16UNC HEX NUT
61	1	910013	3/4UNF HEX NUT
62	2	615840	LEG HYD TUBE ASSY, 204SP 07
63	1	616432	08-381-08MJ-08FX45-15 H/A
64	2	616433	10-381-10MJ-10FX45-17 H/A
65	1	357950	STALK GUIDE WLD, 204 07
66	2	900266	1/2UNC X 1 3/4 HEX BOLT
67	2	470276	CLAMP COVER PLATE, SNGL, 2.55LG
68	1	610013	ZERK BOLT, 5/8 X 1 1/4 TORQ HUB
69	1	900075	5/16UNC X 3 3/4 HEX BOLT
70	2	470113	5/16UNC HEX FLANGE LOCK NUT
71	1	606193	SAUER WHL MOTOR, KC-38CC
72	1	900075	5/16UNC X 3 3/4 HEX BOLT
73	1	342637	NYL HOSE SLEEVE, 2.96ID X 54.00
74	1	358759	LEG MT V-PLT WLD, 284T 94
75	3	920000	1/4 SAE FLAT WASHER

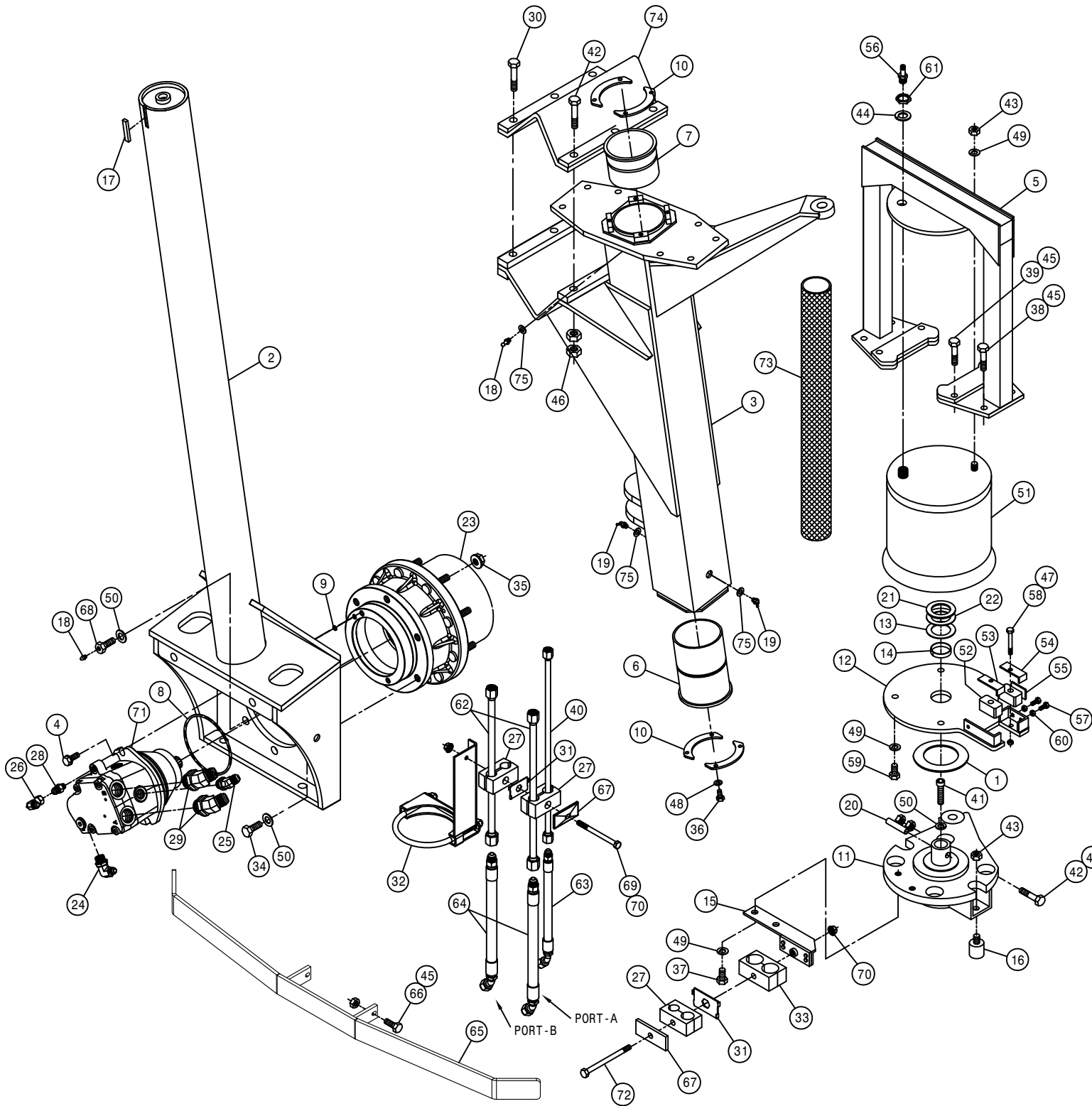

RIGHT REAR LEG ASSEMBLY

DET. QTY PART NO. DESCRIPTION

1	3	920000	1/4 SAE FLAT WASHER
2	1	357859	RH REAR OUTER LEG WLD,204SP 01
3	1	357942	FRT INNER LEG WLD, 204SP
4	1	357865	AIR BAG ARCH WLD,LF/RR204SP 07
5	2	900197	7/16UNC X 1 1/2 HEX BOLT
6	1	358564	FRT LEG LWR NYL SLEEVE 280 89
7	1	358565	FRT LEG UPR NYL SLEEVE 280 89
8	1	606197	O-RING,4.737ID-.103CS-4.943OD
9	1	606198	O-RING, .239ID-.070CS-.379OD
10	4	358927	LWR BRG KPR, LEG 98
11	1	358972	STEERING ARM WLD,LF/RR 2100 99
12	1	358981	AIR BAG MT WLD, LF/RR 2100 99
13	1	358994	LEG WASHER, NYLON 2100 99
14	1	358995	NYLON BEARING,LWR AB MT2100 99
15	2	470259	URETHANE BUMPER,1.25D X 1.25L .250 X .375 CFFL X 1.88 C/L
16	2	471005	GREASE ZERK, 1/4 28 X 1/2
17	2	471023	GREASE ZERK 1/4-28 X 45
18	1	473906	ROLL PIN, 1/2 X 2 1/2 COILED
19	1	483061	WASH: 7GA X 1.66 X 2.50
20	1	483062	WASH: 11GA X 3.03 X 4.63
21	1	483063	WASH: 14GA X 1.66 X 2.50
22	1	606203	SAUER WHL MOTOR, KC-38CC W/SEN
23	1	610832	TORQ HUB,19:1,7HPA W/BRAKE
24	1	618119	9/16MJIC-90-9/16MOR LBO
25	1	618304	9/16MJIC-7/16MOR ADPTR
26	2	618786	7/8MJIC-45-1 1/16MOR LBO
27	1	618618	9/16MJIC-90-9/16FJIC SWIV LBO
28	1	358759	LEG MT V-PLT WLD, 284T 94
29	1	618315	3/4MJIC-45-3/4MOR LBO
30	1	357947	LF/RR TUBE MT WLD, 204 07
31	3	900837	5/8UNF X 3 1/2 HEX BOLT GR8
32	3	342635	NYL HOSE SLEEVE,2.64ID X 60.00
33	1	357950	STALK GUIDE WLD, 204 07
34	5	900332	5/8UNC X 1 1/4 HEX BOLT
35	8	900064	5/16UNC X 3/4 HEX BOLT
36	2	900266	1/2UNC X 1 3/4 HEX BOLT
37	1	470113	5/16UNC HEX FLANGE LOCK NUT
38	4	900265	1/2UNC X 1 1/2 HEX BOLT
39	4	900267	1/2UNC X 2" HEX BOLT
40	1	615841	LEG CASE DRN TUBE ASSY,204SP07
41	1	900390	5/8UNC X 2 1/2 SOCKET CAP SCR
42	4	900836	5/8UNF X 3 1/4 HEX BOLT GR8
43	3	910008	1/2UNC HEX NUT
44	1	610013	ZERK BOLT,5/8 X 1 1/4 TORQ HUB
45	10	914008	1/2UNC HEX STOVER NUT
46	14	914811	5/8UNF HEX NUT GR8
47	8	920506	3/4 LOCK WASHER
48	8	920501	5/16 LOCK WASHER
49	5	920504	1/2 LOCK WASHER
50	7	920505	5/8 LOCK WASHER
51	2	358831	AIRIDE SPRING 98
52	3	358990	NYLON GUIDE, 2100 LEG 99
53	1	358991	INNER KEEPER,NYL GUIDE,2100 99
54	1	358992	OUTER KEEPER,NYL GUIDE,2100 99
55	1	358993	.125 X 1.000 HRST X 1.68 C/L
56	1	470338	AIR TANK VALVE,1/4MNPT W/CAP
57	2	900065	5/16UNC X 1" HEX BOLT
58	2	900069	5/16UNC X 2" HEX BOLT
59	4	900264	1/2UNC X 1 1/4 HEX BOLT
60	2	910002	5/16UNC HEX NUT
61	1	910013	3/4UNF HEX NUT
62	2	914002	5/16UNC HEX STOVER NUT
63	2	615840	LEG HYD TUBE ASSY, 204SP 07
64	1	616432	08-381-08MJ-08FJX45-15 H/A
65	2	616433	10-381-10MJ-10FJX45-17 H/A
66	8	470140	5/8UNF SMITH FLANGE HEX NUT GR8
67	2	470270	HOSE CLAMP BODY, .530-.680
68	1	470276	CLAMP COVER PLATE,SNGL, 2.55LG
69	1	470281	STACK BOLT SAFETY LOCK PLATE
70	1	900075	5/16UNC X 3 3/4 HEX BOLT
71	1	606192	SPEED SENSOR,WHEEL MTR 606183
72	1		

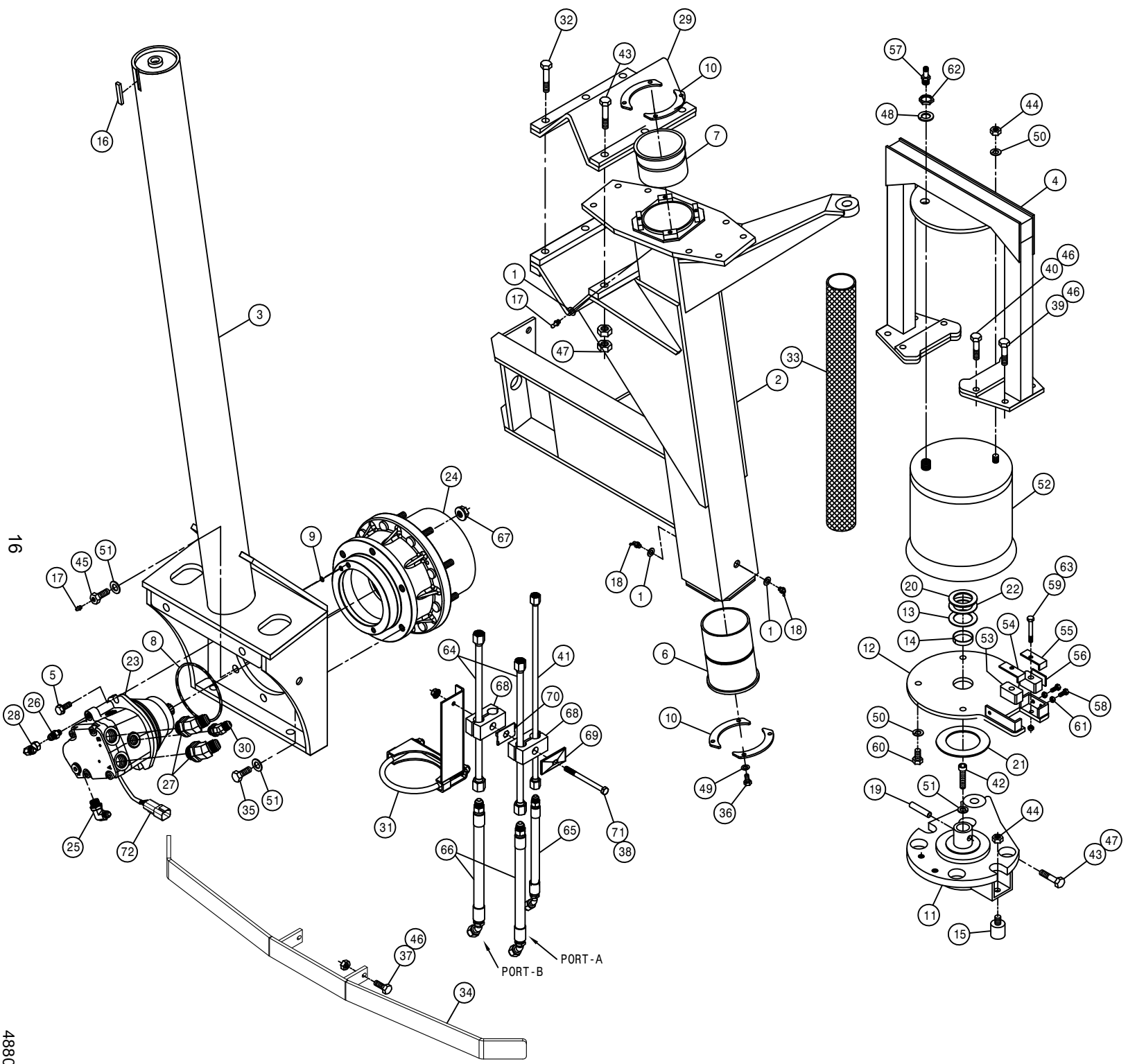

16

488016

LEFT REAR LEG ASSEMBLY

DET.	QTY	PART NO.	DESCRIPTION
1	1	357860	LH REAR OUTER LEG WLD,204SP 01
2	1	610832	TORQ HUB,19-1,7HPA W/BRAKE
3	1	357864	AIR BAG ARCH WLD,RF/LR204SP 01
4	2	618786	7/8MJIC-45-1 1/16MOR LBO
5	1	358564	FRT LEG LWR NYL SLEEVE 280 89
6	1	358565	FRT LEG UPR NYL SLEEVE 280 89
7	5	900332	5/8UNC X 1 1/4 HEX BOLT
8	1	618119	9/16MJIC-90-9/16MOR LBO
9	4	358927	LWR BRG KPR, LEG 98
10	1	358971	STEERING ARM WLD,RF/LR 2100 99
11	1	358980	AIR BAG MT WLD, RF/LR 2100 99
12	1	358994	LEG WASHER, NYLON 2100 99
13	1	358995	NYLON BEARING,LWR AB MT2100 99
14	2	470259	URETHANE BUMPER,1.25D X 1.25L
15	1	470265	.250 X .375 CFFL X 1.88 C/L
16	2	471005	GREASE ZERK, 1/4 28 X 1/2
17	2	471023	GREASE ZERK 1/4-28 X 45
18	1	473906	ROLL PIN, 1/2 X 2 1/2 COILED
19	1	483061	WASH: 7GA X 1.66 X 2.50
20	1	483062	WASH: 11GA X 3.03 X 4.63
21	1	483063	WASH: 14GA X 1.66 X 2.50
22	1	618618	9/16MJIC-90-9/16FJIC SWIV LBO
23	1	618304	9/16MJIC-7/16MOR ADPTR
24	1	618634	9/16MJIC-45-9/16FJIC SWIV LBO
25	1	606193	SAUER WHL MOTOR,KC-38CC
26	1	358759	LEG MT V-PLT WLD, 284T 94
27	1	606197	O-RING,4.737ID-.103CS-4.943OD
28	1	606198	O-RING, .239ID-.070CS-.379OD
29	2	900197	7/16UNC X 1 1/2 HEX BOLT
30	1	357950	STALK GUIDE WLD, 204 07
31	1	920506	3/4 LOCK WASHER
32	2	914002	5/16UNC HEX STOVER NUT
33	1	910013	3/4UNF HEX NUT
34	2	910002	5/16UNC HEX NUT
35	8	900064	5/16UNC X 3/4 HEX BOLT
36	4	900264	1/2UNC X 1 1/4 HEX BOLT
37	4	900265	1/2UNC X 1 1/2 HEX BOLT
38	2	900069	5/16UNC X 2" HEX BOLT
39	4	900267	1/2UNC X 2" HEX BOLT
40	1	615841	LEG CASE DRN TUBE ASSY,204SP07
41	1	900390	5/8UNC X 2 1/2 SOCKET CAP SCR
42	4	900836	5/8UNF X 3 1/4 HEX BOLT GR8
43	3	910008	1/2UNC HEX NUT
44	2	900065	5/16UNC X 1" HEX BOLT
45	10	914008	1/2UNC HEX STOVER NUT
46	14	914811	5/8UNC HEX NUT GR8
47	1	470338	AIR TANK VALVE,1/4MNPT W/CAP
48	8	920501	5/16 LOCK WASHER
49	1	358993	.125 X 1.000 HRST X 1.68 C/L
50	7	920505	5/8 LOCK WASHER
51	1	358831	AIRIDE SPRING 98
52	2	358990	NYLON GUIDE, 2100 LEG 99
53	1	358991	INNER KEEPER,NYL GUIDE,2100 99
54	1	358992	OUTER KEEPER,NYL GUIDE,2100 99
55	1	357942	FRT INNER LEG WLD, 204SP 07
56	1	618315	3/4MJIC-45-3/4MOR LBO
57	1	357946	RF/LR TUBE MT WLD, 204 07
58	1	610013	ZERK BOLT,5/8 X 1 1/4 TORQ HUB
59	5	920504	1/2 LOCK WASHER
60	3	900837	5/8UNF X 3 1/2 HEX BOLT GR8
61	2	615840	LEG HYD TUBE ASSY, 204SP 07
62	1	616432	08-381-08MJ-08FJX45-15 H/A
63	2	616433	10-381-10MJ-10FJX45-17 H/A
64	2	900266	1/2UNC X 1 3/4 HEX BOLT
65	2	470270	HOSE CLAMP BODY, .530-.680
66	1	470276	CLAMP COVER PLATE,SNGL, 2.55LG
67	1	470281	STACK BOLT SAFETY LOCK PLATE
68	1	900075	5/16UNC X 3 3/4 HEX BOLT
69	1	470113	5/16UNC HEX FLANGE LOCK NUT
70	8	470140	5/8UNF SMTH FLANGE HEX NUT GR8
71	1	342635	NYL HOSE SLEEVE,2.64ID X 60.00
72	3	920000	1/4 SAE FLAT WASHER

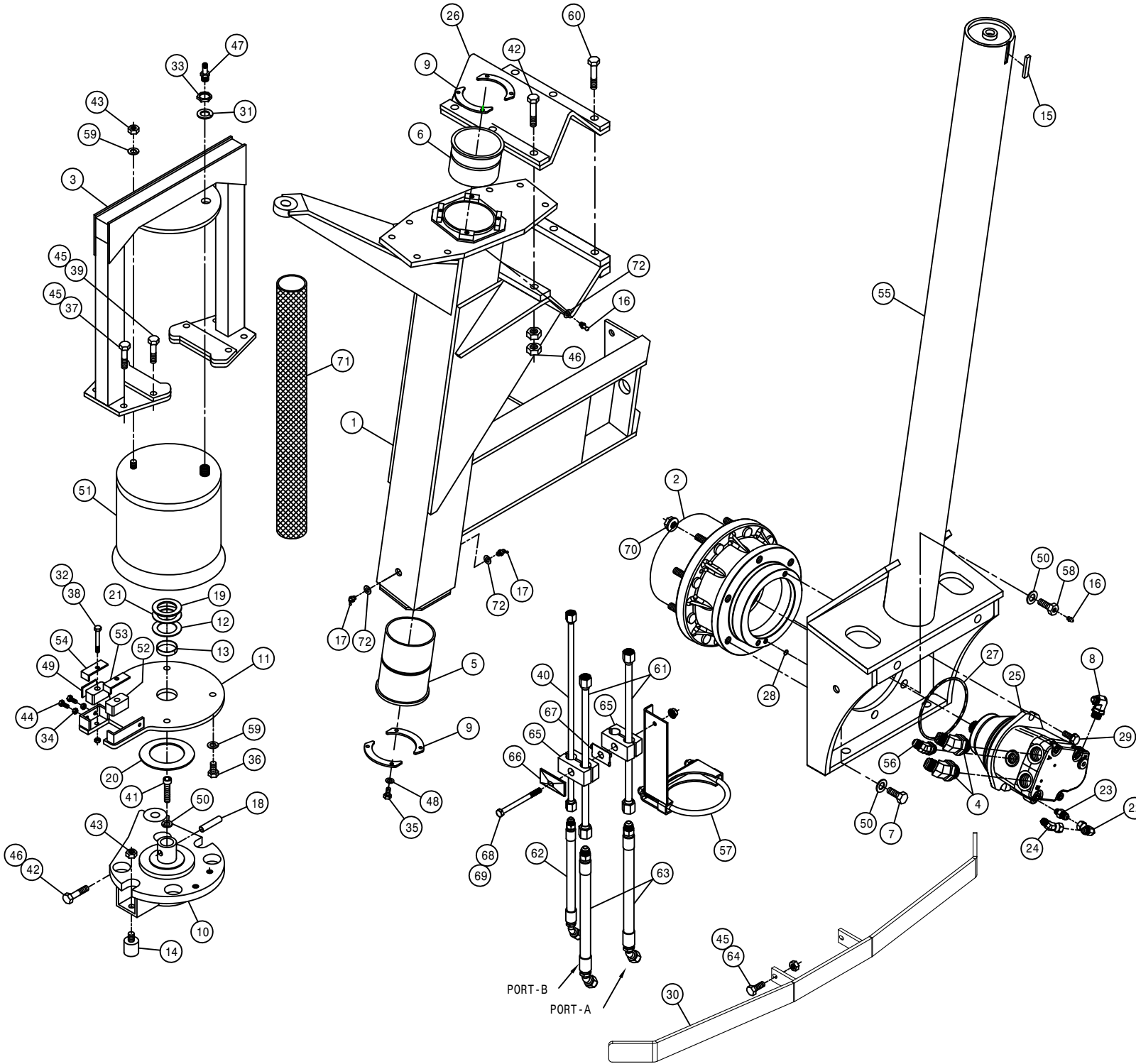

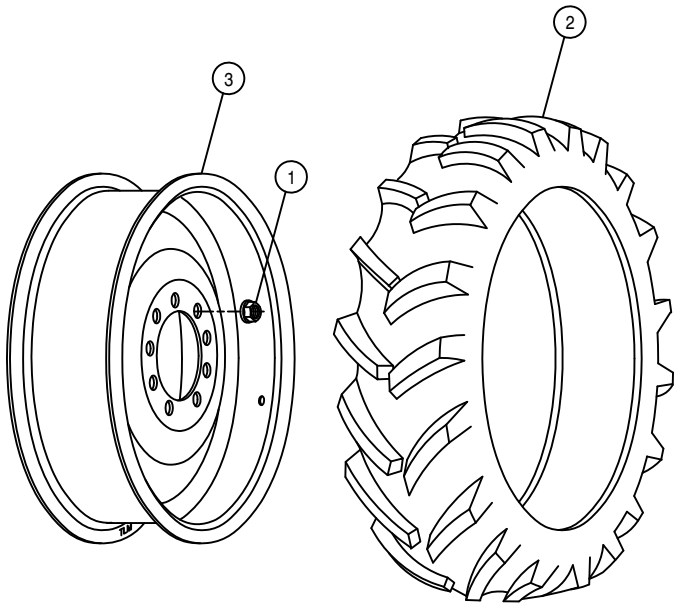

TIRE RIM ASSEMBLY

DET.	QTY	PART NO.	DESCRIPTION
1	9	470140	5/8UNF SMTH FLANGE HEX NUT GR8
2	1	820063	11.2-38 TL GOODYEAR TIRE
3	1	821050	RIM WLD, W10 X 38, W1M1 204

BRAKE/SHIFT SOLENOID ASSEMBLY

DET. QTY PART NO. DESCRIPTION

1	2	610318	HYD SOLE VLV,2P-3W,9/16FOR,12V
2	2	610016	COIL FOR HYD VLV 610318
3	2	293163	TYCO,FASTON,.250(16-14GA),MALE
4	2	291512	RING TERM,.375(16-14GA),INS
5	1	610797	BRAKE/SHIFT SOL VLV MT, 204I
6	5	618119	9/16MJIC-90-9/16MOR LBO
7	1	618444	9/16MOR RUN TEE-9/16MJIC
8	3	618486	9/16FJIC SW RUN TEE-9/16MJIC
9	4	900006	1/4UNC X 1 3/4 HEX BOLT
10	4	914000	1/4UNC HEX STOVER NUT
11	2	618618	9/16MJIC-90-9/16FJIC SWIV LBO
12	1	900129	3/8UNC X 1" SERR FLANGE BOLT
13	1	914004	3/8UNC HEX STOVER NUT

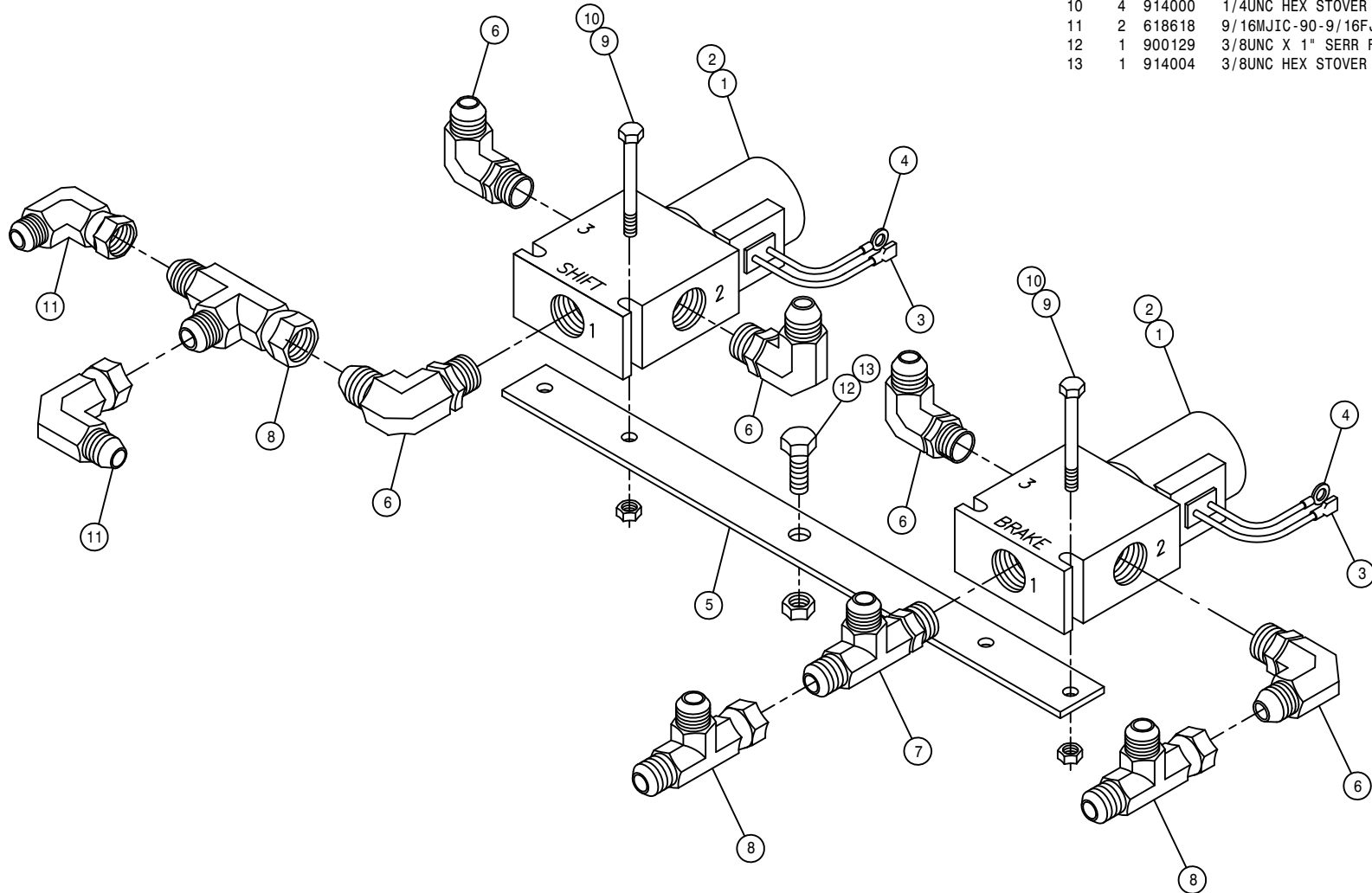

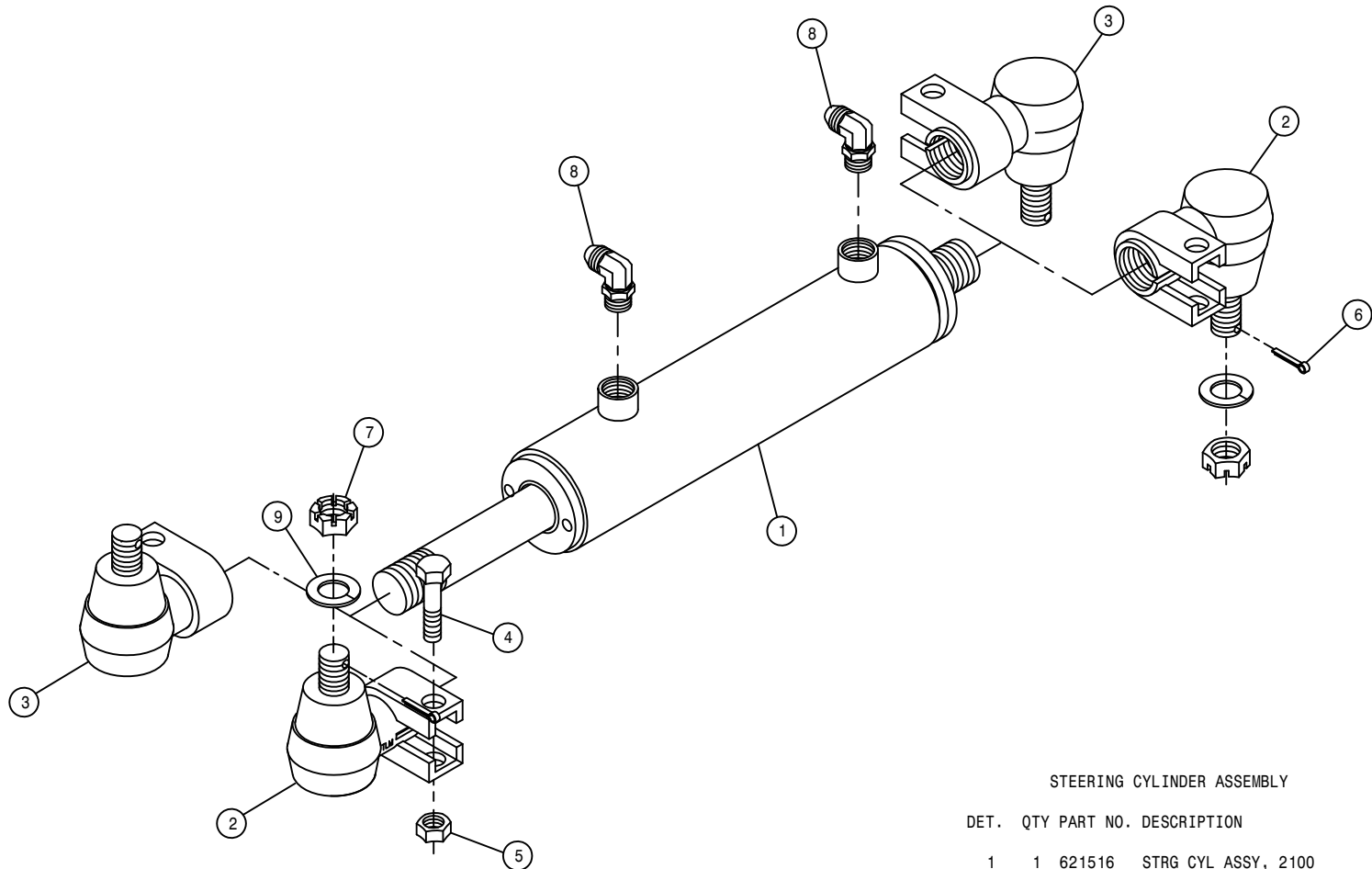

STEERING CYLINDER ASSEMBLY

DET.	QTY	PART NO.	DESCRIPTION
	1	621516	STRG CYL ASSY, 2100
	2	749312	RH STRG CYL SWIV ASSY
	2	749313	LH STRG CYL SWIV ASSY
	2	900268	1/2UNC X 2 1/2 HEX BOLT
	2	914008	1/2UNC HEX STOVER NUT
	2	390984	COTTER PIN 1/8 X 1 1/4
	2	822040	5/8-18UNF SLOTTED HEX NUT
	2	618119	9/16MJIC-90-9/16MOR LBO
	2	920505	5/8 LOCK WASHER
	1	621517	REPAIR KIT, HYD CYL 621516

NOTE: 1. 621205 - RH STEERING CYLINDER ASSEMBLY W/CYL SWIV DET.2
 2. 621206 - LH STEERING CYLINDER ASSEMBLY W/CYL SWIV DET.3

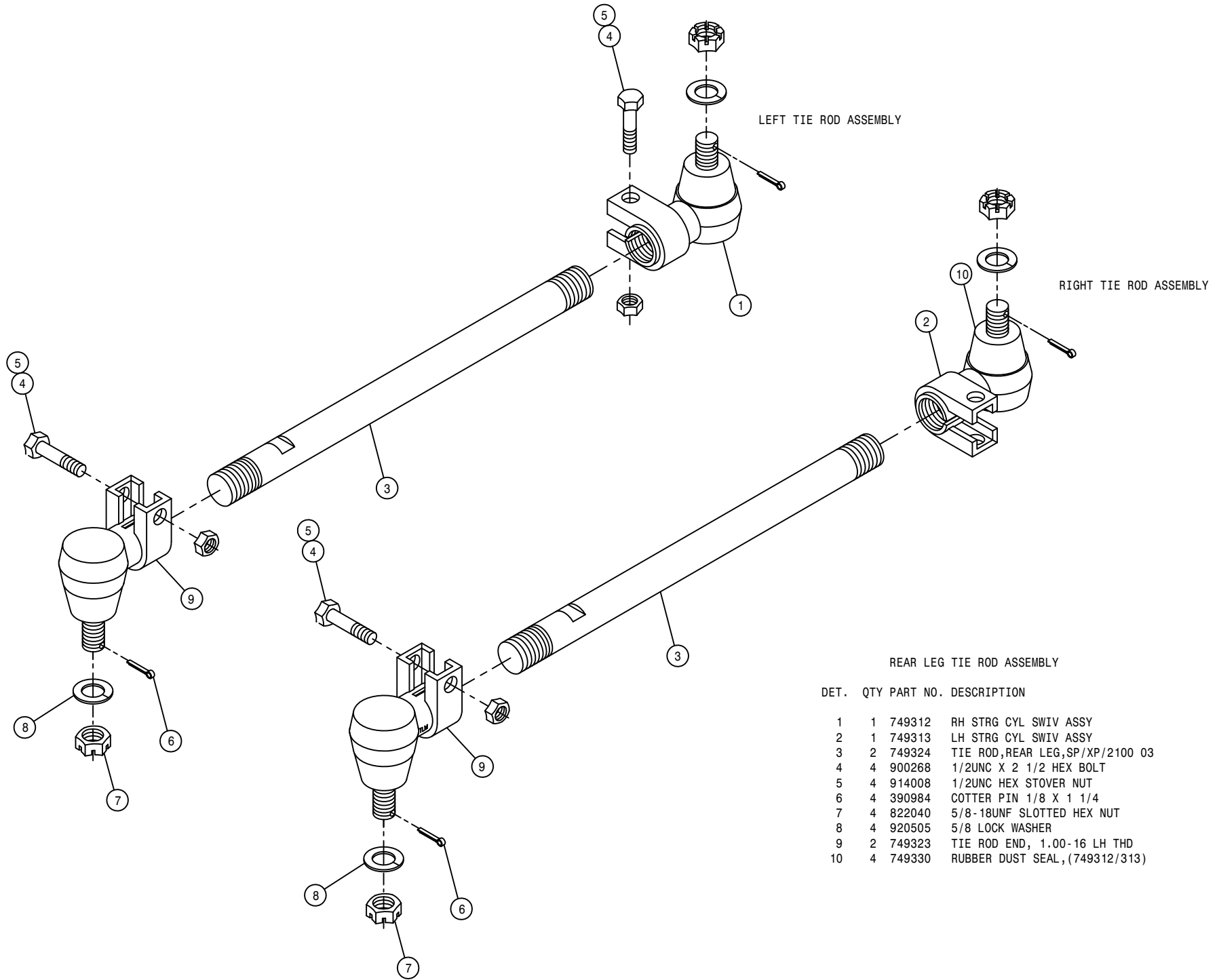

REAR LEG TIE ROD ASSEMBLY

DET.	QTY	PART NO.	DESCRIPTION
1	1	749312	RH STRG CYL SWIV ASSY
2	1	749313	LH STRG CYL SWIV ASSY
3	2	749324	TIE ROD,REAR LEG,SP/XP/2100 03
4	4	900268	1/2UNC X 2 1/2 HEX BOLT
5	4	914008	1/2UNC HEX STOVER NUT
6	4	390984	COTTER PIN 1/8 X 1 1/4
7	4	822040	5/8-18UNF SLOTTED HEX NUT
8	4	920505	5/8 LOCK WASHER
9	2	749323	TIE ROD END, 1.00-16 LH THD
10	4	749330	RUBBER DUST SEAL,(749312/313)

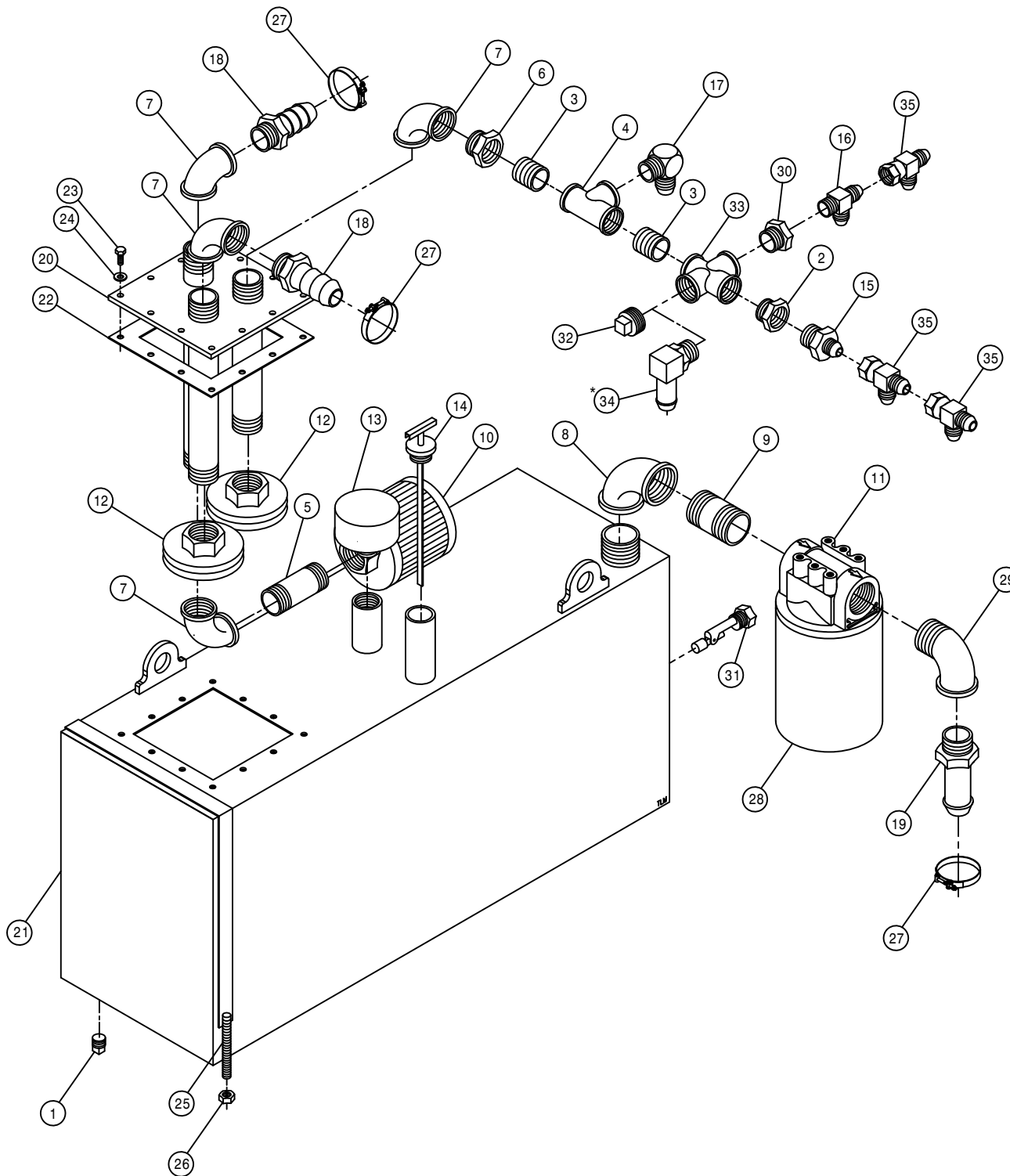

HYDRAULIC TANK ASSEMBLY

DET. QTY PART NO. DESCRIPTION

1	1	470308	1/2MNPT DRAIN PLUG,AL HD,MAG
2	1	504210	RED BUSH 3/4 NPT X 1/2 NPT
3	2	504702	CLOSE NIPPLE .75NPT
4	1	504955	BLK PIPE TEE .75NPT
5	1	505203	BLK PIPE NIPPLE 1.00NPT-4.00
6	1	505213	RED BUSH 1 X 3/4 BLK MAL
7	4	505300	BLK PIPE EL 90DEG 1.00NPT
8	1	506303	BLK PIPE EL 90DEG 1.25NPT
9	1	506602	PIPE NIPPLE 1 1/4NPT-2 1/2
10	1	605600	TANK FILTER, 100 MESH,1"FNPT
11	1	605601	PARKER FILTER ASSY,10M,1.25NPT
12	2	605603	LINE SUMP DIFFUSER
13	1	611052	FILLER BREATHER 3/4NPT
14	1	614453	DIPSTICK, 8IN
15	1	618018	9/16MJIC-1/2MNPT ADPTR
16	1	618520	1/4MNPT RUN TEE-9/16MJIC
17	1	610305	3/4MJIC-90-3/4MNPT LBO
18	2	714560	1NPT X 1 HOSE BARB
19	1	715664	1 1/4 NPT X 1 HOSE BARB
20	1	760090	RECEIVER PLT WLD 8240
21	1	760264	HYD TANK WLD,204/254/284 2002
22	1	763039	HYD MTR MTG PLT GSKT
23	12	900064	5/16UNC X 3/4 HEX BOLT
24	12	920001	5/16 SAE FLAT WASHER
25	2	341360	OIL TANK STRAP WLD 8240 1982
26	4	914004	3/8UNC HEX STOVER NUT
27	3	520138	1.38/1.56 T-BOLT HOSE CLAMP
28	1	605602	PARKER FILTER ELEMENT,10MICRON
29	1	506410	BLK PIPE ST EL 90DEG 1.25NPT
30	1	504001	RED BUSH 3/4 X 1/4 BLK MAL
31	1	470350	LIQUID LEVEL SWITCH ASSY,1/2NP
32	1	504900	PIPE PLUG .75NPT SQ HD
33	1	504400	BLK PIPE CROSS .75NPT
34	1	618135	3/4 HOSE BARB-90-3/4MNPT
35	3	618486	9/16FJIC SW RUN TEE-9/16MJIC

*NOTE: DETAIL 34 IS USED WITH THE CUTTER OPTION.

NEW TANK REPLACEMENT KIT-KSP008

FUEL TANK ASSEMBLY

DET. QTY PART NO. DESCRIPTION

1	2	291428	FUEL SENDER 19 IN.
2	10	473902	#8 X 1/2 PHIL PAN HD MTL SCR
3	2	501102	1/4 PIPE PLUG
4	4	760895	FUEL SUCTION DROP TUBE, 204
5	2	760883	FUEL TANK WLD SS
6	4	470409	3/8UNC X 3/4 SER FLG BOLT
7	2	711081	1/2MNPT - 5/16 BARB, BRS
8	2	601355	HOSE, 3/8 X 100 FUEL LINE
9	1	760153	RH FUEL TNK MT WLD 200-280 90
10	1	760154	LH FUEL TNK MT WLD 200-280 90
11	2	711080	1/2MNPT - 3/8 BARB, BRS
12	1	610529	FUEL SELECTOR VALVE W/RETURN
13	4	470121	1/4UNC SER FLG LOCK NUT
14	1	601139	HOSE, 5/16 X 16 FUEL LINE
15	8	914008	1/2UNC HEX STOVER NUT
16	2	601301	HOSE, 5/16 X 90 FUEL LINE
17	10	520120	HOSE CLAMP NO 4 STAINLESS
18	2	900064	5/16UNC X 3/4 HEX BOLT
19	8	470087	3/8UNC HEX SER FLG NUT
20	8	900264	1/2UNC X 1 1/4 HEX BOLT
21	4	900128	3/8UNC X 3/4 HEX BOLT YZ
22	1	601757	HOSE, 3/8 X 50 FUEL LINE
23	2	291464	GSKT FUEL SENDER, FOR291428
24	2	760469	FUEL TANK CAP, 3.50" VENTED

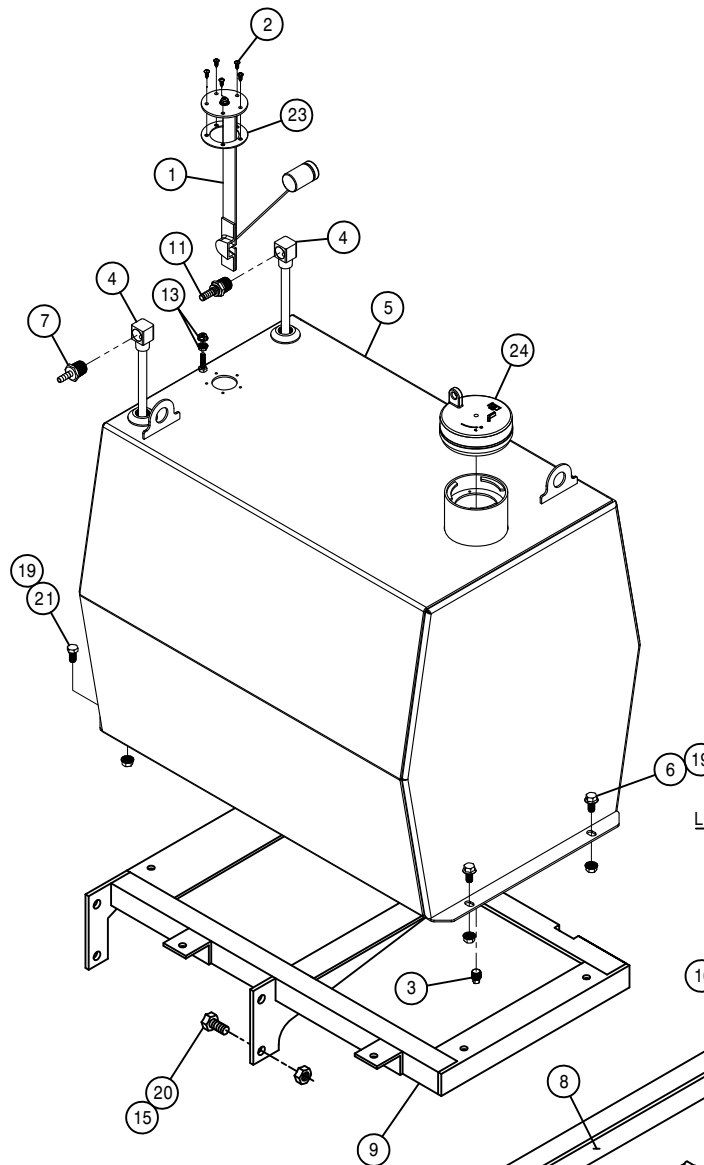

LEFT TANK ASSEMBLY

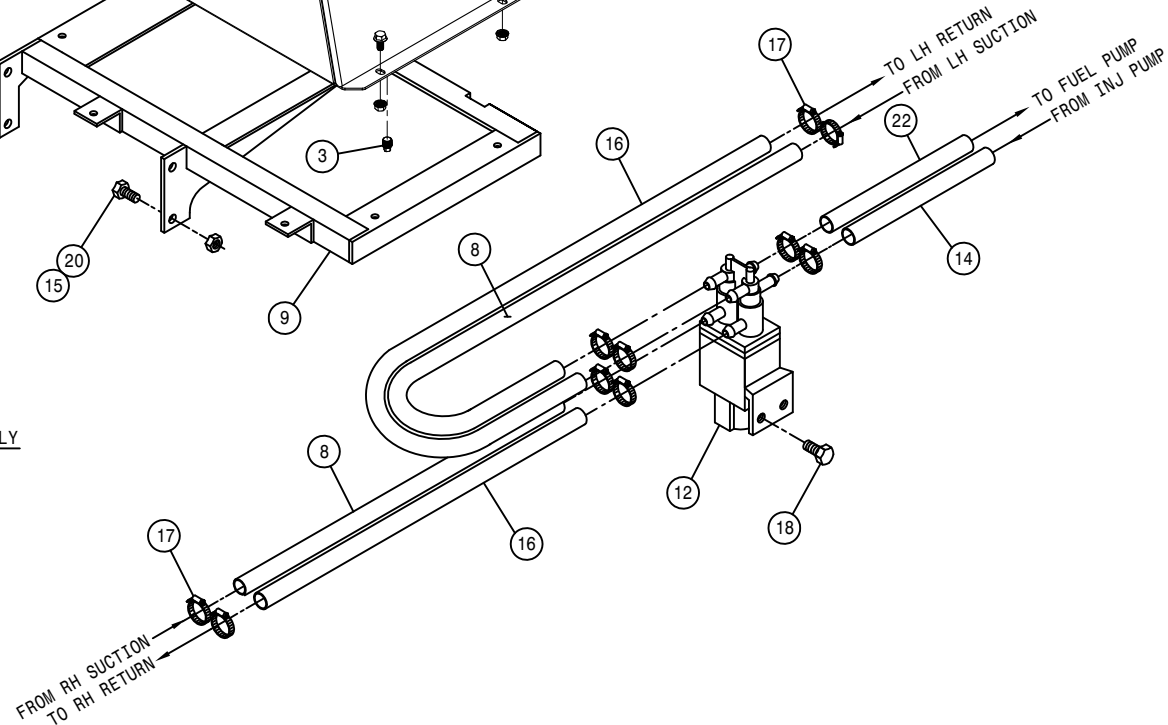

RIGHT TANK ASSEMBLY

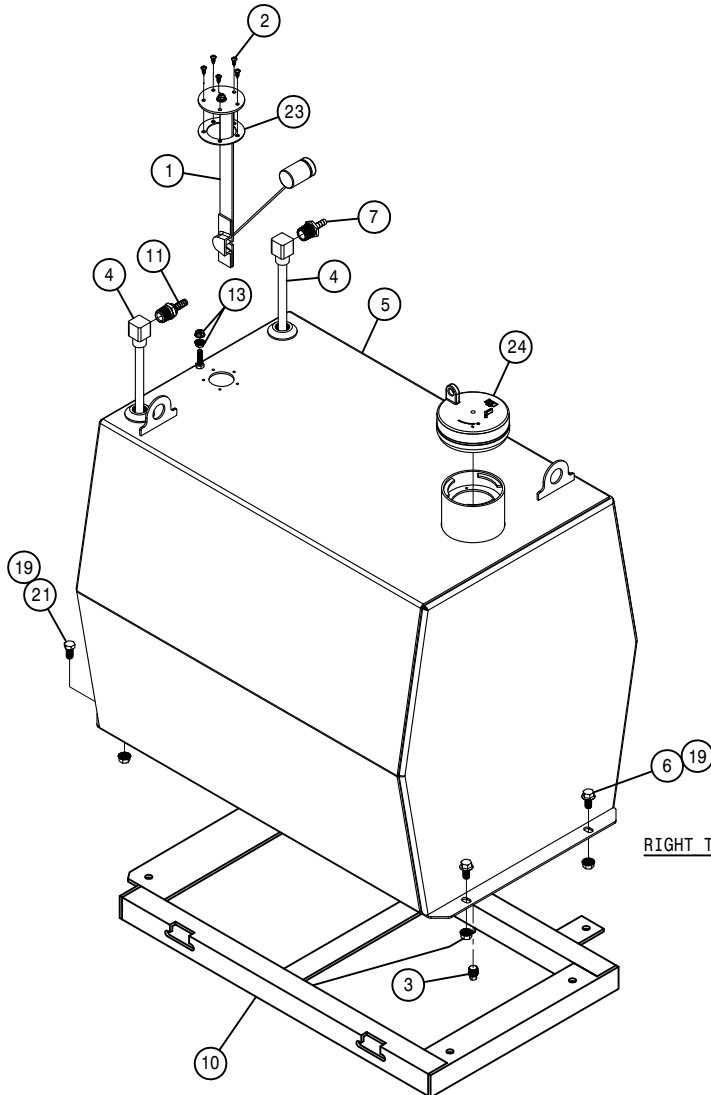

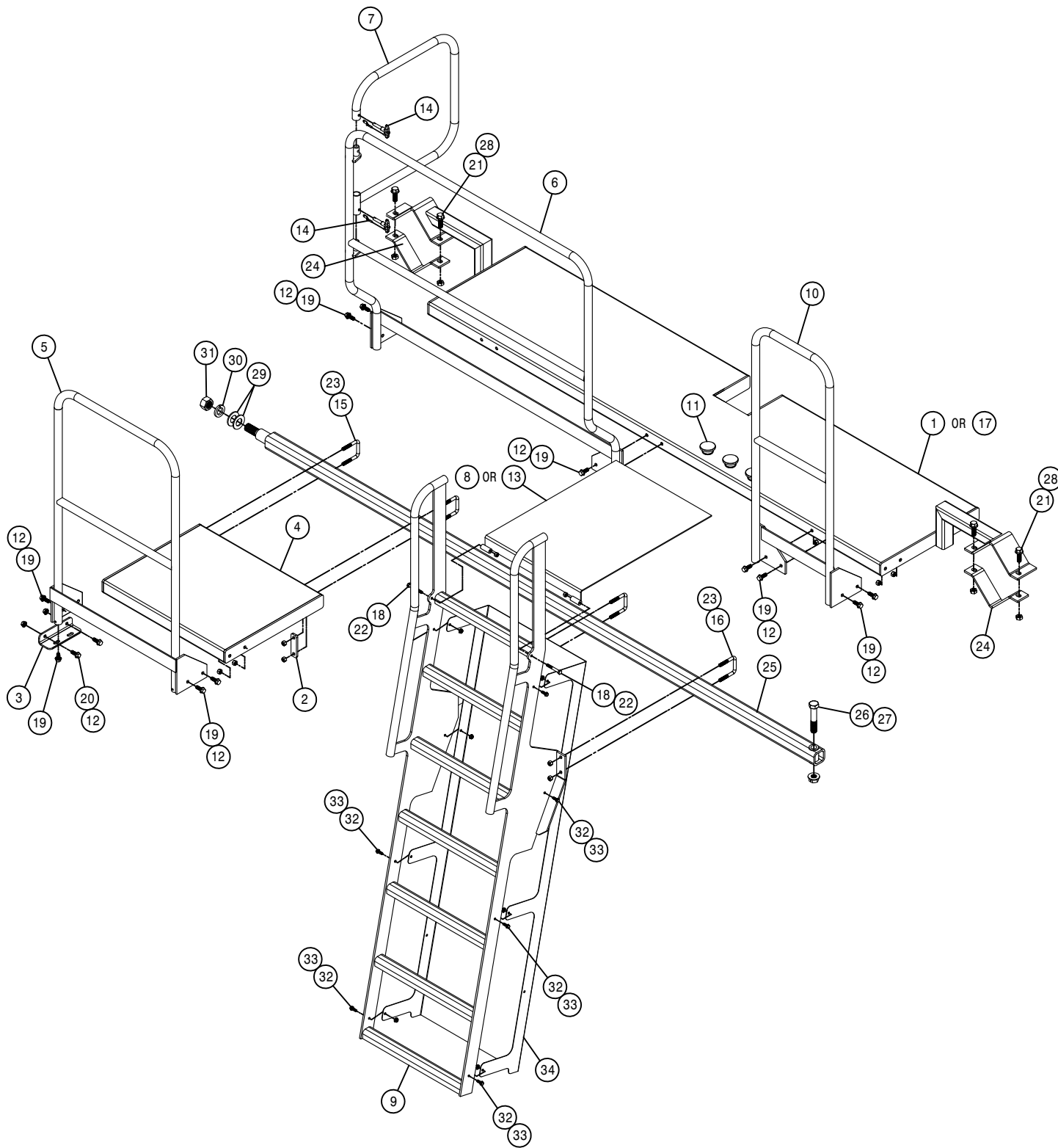

RH LADDER AND SERVICE PLATFORM ASSEMBLY

DET. QTY PART NO. DESCRIPTION

1	1	343720	RH SERV PLATFORM WLD,204SP '11
2	2	343729	REAR PLTFRM UBOLT KPR,204SP '11
3	1	343730	REAR PLTFRM SUPP ANGL,204SP '11
4	1	343733	FUEL TANK PLTFRM WLD,204SP '11
5	1	343735	REAR HANDRAIL WLD, 204SP '11
6	1	343739	RH REAR HANDRAIL WLD, 204SP '11
7	1	343770	REAR HANDRAIL EXT WLD,204SP '11
8	1	343781	BRIDGE PLATE WLDMNT
9	1	343783	LADDER WLD, 18" 204SP '10
10	1	343737	RH FRT HANDRAIL WLD, 204SP '11
11	1	343819	BRIDGE PLT WEAR PUCK 204SP '11
12	14	470087	3/8UNC HEX FLANGE LOCK NUT
13	1	343817	BRIDGE PLT WLD,204SPW
14	2	470857	3/8"PIN,T-HANDLE QK-REL,W/LAN
15	2	472040	3/8UNC-2.18ID-2.81 U-BOLT SQ
16	2	472044	3/8UNC-2ID-3.00 U-BOLT SQ,ZINC
17	1	343788	CAB SERV PLATFORM WLD,204SP '11
18	2	900086	5/16UNC X 2 1/4 HEX BOLT
19	12	900128	3/8UNC X 3/4 HEX BOLT
20	2	900129	3/8UNC X 1" SERR FLANGE BOLT
21	4	900265	1/2UNC X 1 1/2 HEX BOLT
22	2	914002	5/16UNC HEX STOVER NUT
23	8	914004	3/8UNC HEX STOVER NUT
24	2	341900	SERVICE PLATFORM MT KPR 90
25	1	358673	LEG BRACE WLD 200 92
26	1	900410	3/4UNC X 4" HEX BOLT
27	1	914012	3/4UNC HEX STOVER NUT
28	4	914008	1/2UNC HEX STOVER NUT
29	2	920008	1" SAE FLAT WASHER
30	1	920508	1" LOCK WASHER
31	1	910017	1-8 HEX NUT
32	8	470118	1/4UNC X 3/4 FLANGE HEX BOLT
33	8	470121	1/4UNC HEX FLANGE LOCK NUT
34	1	343787	204 CE LADDER BACK STOP

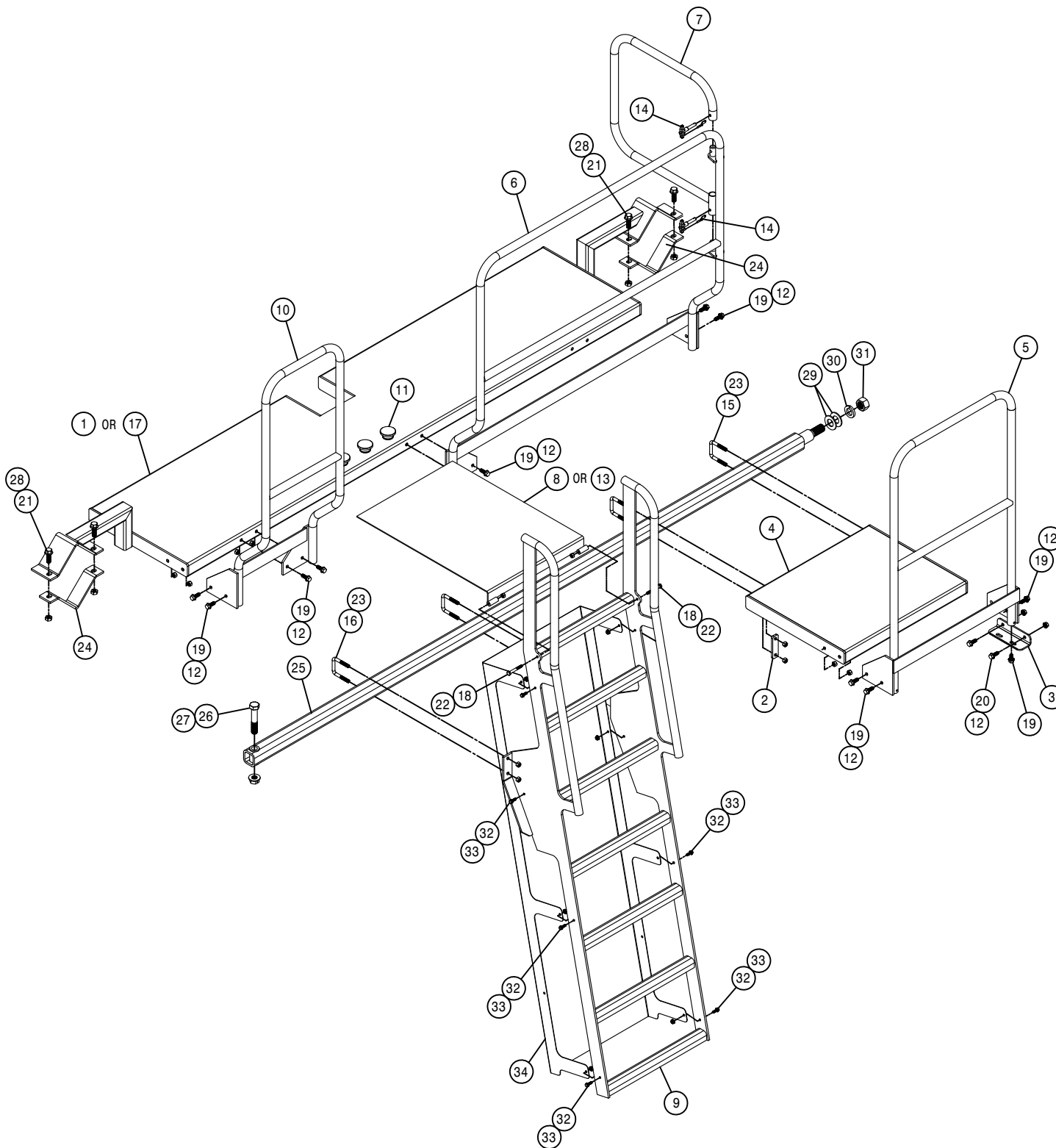

LH LADDER AND SERVICE PLATFORM ASSEMBLY

DET. QTY PART NO. DESCRIPTION

1	1	343721	LH SERV PLATFORM WLD,204SP '11
2	2	343729	REAR PLTFRM UBOLT KPR,204SP'11
3	1	343730	REAR PLTFRM SUPP ANGL,204SP'11
4	1	343733	FUEL TANK PLTFRM WLD,204SP '11
5	1	343735	REAR HANDRAIL WLD, 204SP '11
6	1	343740	LH REAR HANDRAIL WLD, 204SP'11
7	1	343770	REAR HANDRAIL EXT WLD,204SP'11
8	1	343781	BRIDGE PLATE WLDMNT
9	1	343783	LADDER WLD, 18" 204SP '10
10	1	343790	FRT HANDRAIL WLD,204SP '11
11	3	343819	BRIDGE PLT WEAR PUCK 204SP'11
12	14	470087	3/8UNC HEX FLANGE LOCK NUT
13	1	343817	BRIDGE PLT WLD,204SPW
14	2	470857	3/8"PIN,T-HANDLE QK-REL,W/LAN
15	2	472040	3/8UNC-2.18ID-2.81 U-BOLT SQ
16	2	472044	3/8UNC-2ID-3.00 U-BOLT SQ,ZINC
17	1	343788	CAB SERV PLATFORM WLD,204SP '11
18	2	900086	5/16UNC X 2 1/4 HEX BOLT
19	12	900128	3/8UNC X 3/4 HEX BOLT
20	2	900129	3/8UNC X 1" SERR FLANGE BOLT
21	4	900265	1/2UNC X 1 1/2 HEX BOLT
22	2	914002	5/16UNC HEX STOVER NUT
23	8	914004	3/8UNC HEX STOVER NUT
24	2	341900	SERVICE PLATFORM MT KPR
25	1	358673	LEG BRACE WLD 200
26	1	900410	3/4UNC X 4" HEX BOLT
27	1	914012	3/4UNC HEX STOVER NUT
28	4	914008	1/2UNC HEX STOVER NUT
29	2	920008	1" SAE FLAT WASHER
30	1	920508	1" LOCK WASHER
31	1	910017	1-8 HEX NUT
32	8	470118	1/4UNC X 3/4 FLANGE HEX BOLT
33	8	470121	1/4UNC HEX FLANGE LOCK NUT
34	1	343787	204 CE LADDER BACK STOP

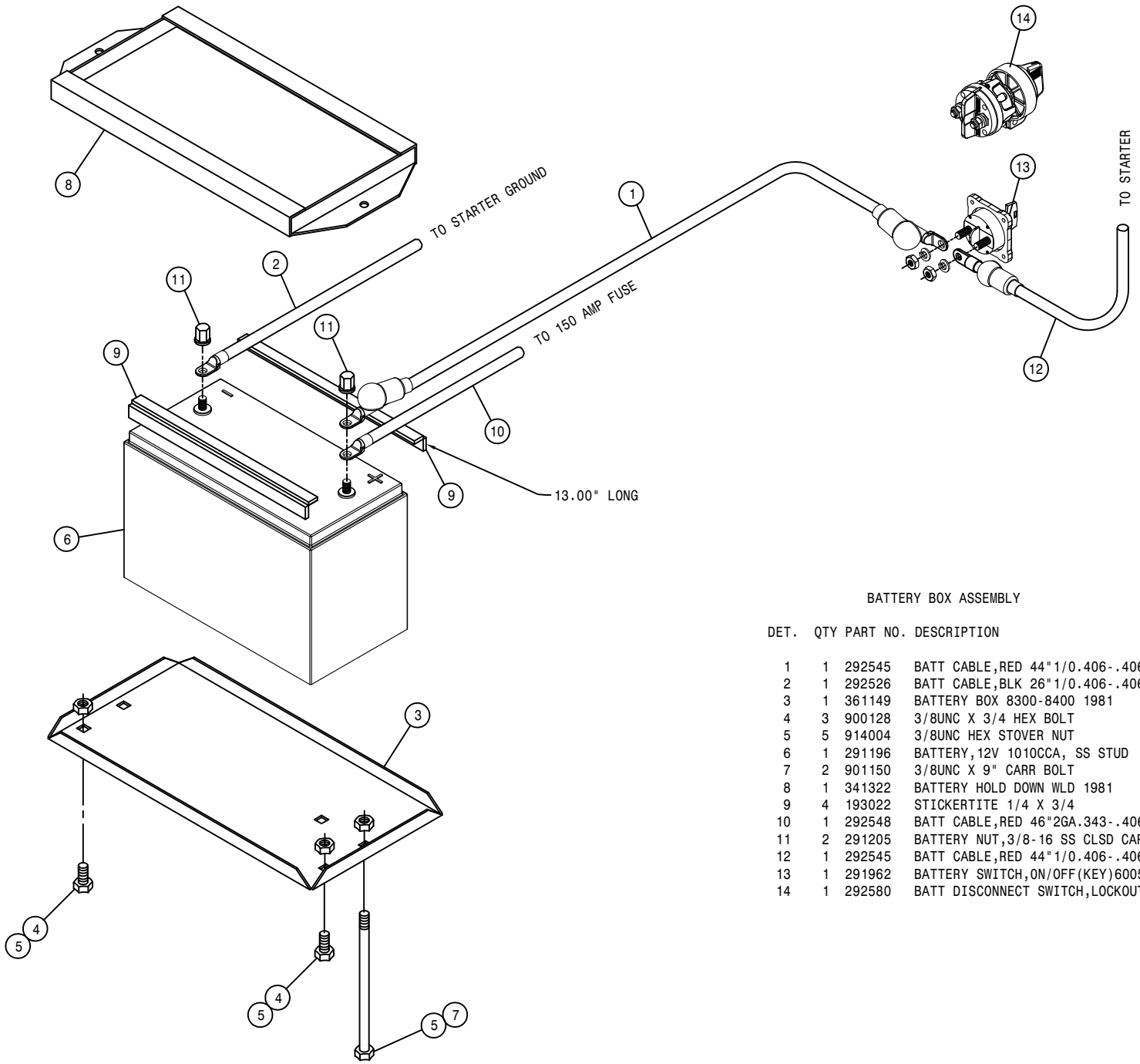

BATTERY BOX ASSEMBLY

DET.	QTY	PART NO.	DESCRIPTION
1	1	292545	BATT CABLE,RED 44"1/0.406-.406
2	1	292526	BATT CABLE,BLK 26"1/0.406-.406
3	1	361149	BATTERY BOX 8300-8400 1981
4	3	900128	3/8UNC X 3/4 HEX BOLT
5	5	914004	3/8UNC HEX STOVER NUT
6	1	291196	BATTERY,12V 1010CCA, SS STUD
7	2	901150	3/8UNC X 9" CARR BOLT
8	1	341322	BATTERY HOLD DOWN WLD 1981
9	4	193022	STICKERTITE 1/4 X 3/4
10	1	292548	BATT CABLE,RED 46"2GA.343-.406
11	2	291205	BATTERY NUT,3/8-16 SS CLSD CAP
12	1	292545	BATT CABLE,RED 44"1/0.406-.406
13	1	291962	BATTERY SWITCH,ON/OFF(KEY)6005
14	1	292580	BATT DISCONNECT SWITCH,LOCKOUT

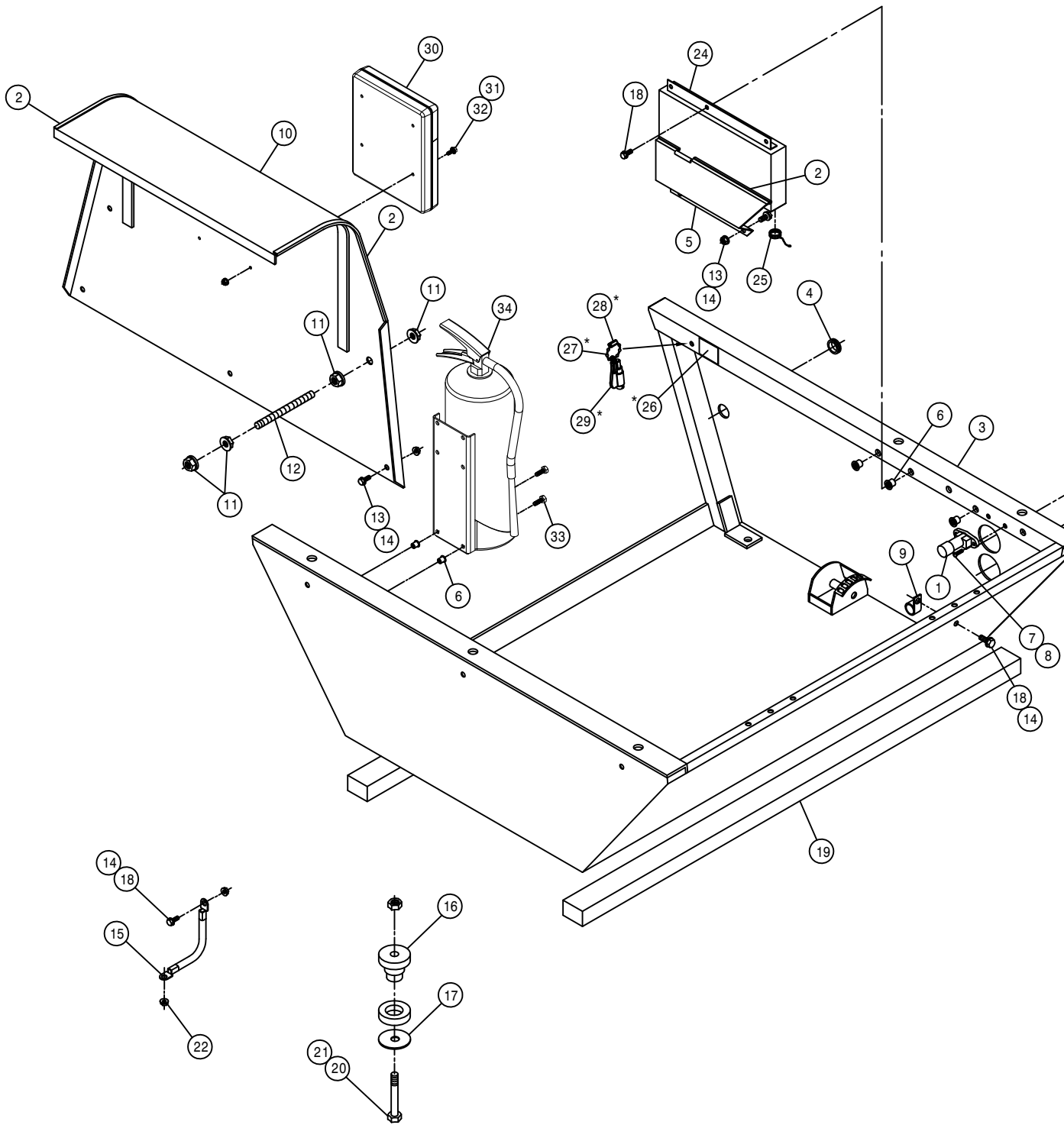

OPERATOR STATION ASSEMBLY

DET.	QTY	PART NO.	DESCRIPTION
1	1	290412	DIMMER SWITCH
2	2	193011	EDGE GUARD, BLK
3	1	343172	OP STN WLD,204/204SP (PAINT)07
4	1	470067	GROMMET, .250ID .125GW .375GD
5	1	002899	LS CTRL BOX CONNECTOR SHLD 96
6	5	470380	1/4-20 NUTSERT .027-.165 STL
7	2	472235	10-32 X 3/4 PHIL PAN MACH SCR
8	2	470175	10-32 HEX FLANGE LOCK NUT
9	1	520121	CUSH CLAMP,#16 1IN X 3/4W
10	1	342098	NOISE DEFLECTOR WELDMT 204
11	8	470087	3/8UNC HEX FLANGE LOCK NUT
12	2	314929	3/8UNC X 3.00 STUD BOLT, FULL
13	5	470122	1/4UNC X 1/2 FLANGE HEX BOLT
14	4	470121	1/4UNC HEX FLANGE LOCK NUT
15	1	290107	GROUND CABLE,8" X 4GA .406LUGS
16	4	311051	RUBBER MOUNT, RB3-350
17	4	311052	SNUBBING WASHER FOR 311051
18	5	470118	1/4UNC X 3/4 FLANGE HEX BOLT
19	2	659704	FOAM, 2"THK X 2" WIDE X 42"LG
20	4	900342	5/8UNC X 4" HEX BOLT
21	4	914010	5/8UNC HEX STOVER NUT
22	1	914004	3/8UNC HEX STOVER NUT
23	2	473915	GROMMET,1.500ID .062GW 1.750GD
24	1	293906	TASSELTRC CABLE BOX ASSY 2008
25	1	293046	AMP,COVER,SIZE 11
26	1	650175	DECAL,NOTICE EMERGENCY EXIT
27	1	470398	BEAD CHAIN, #10 X 4" LONG
28	1	470400	BEAD CHAIN CONNECTOR #10 WHITE
29	1	470397	RES-Q-ME TOOL
30	1	343780	MANUAL HOLDER
31	4	470113	5/16UNC HEX FLANGE LOCK NUT
32	4	900064	5/16UNC X 3/4 HEX BOLT
33	2	900002	1/4UNC X 3/4 HEX BOLT
34	1	490508	FIRE EXTINGUISHER 10LB ABC

NOTE: ITEMS WITH (*) ARE USED WITH THE CAB ASSEMBLY.

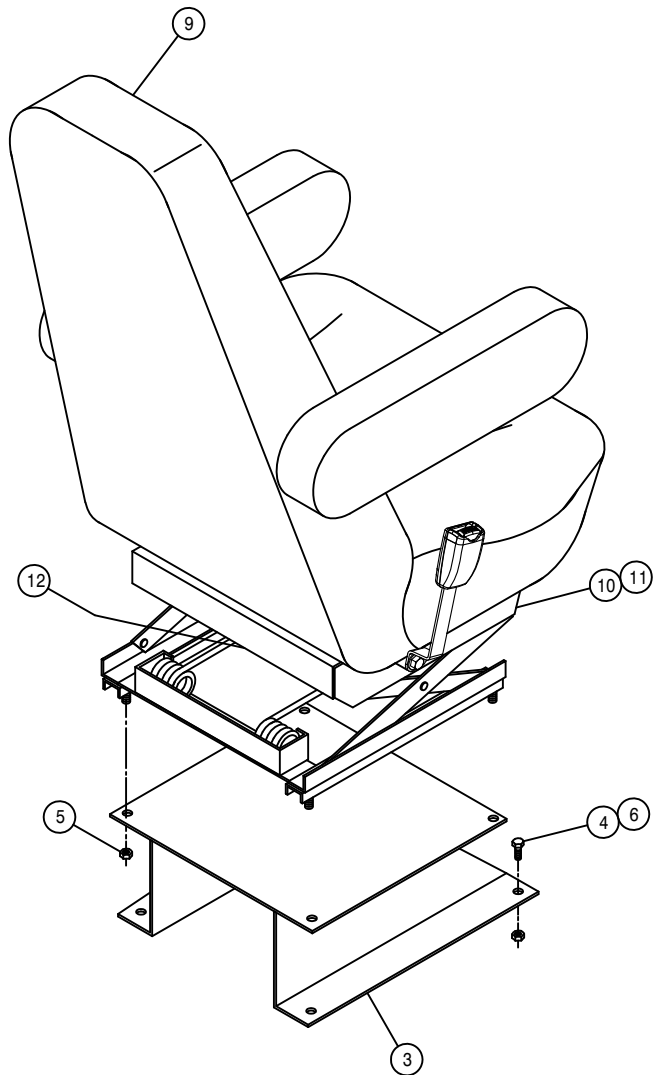

SEAT ASSEMBLY W/CAB

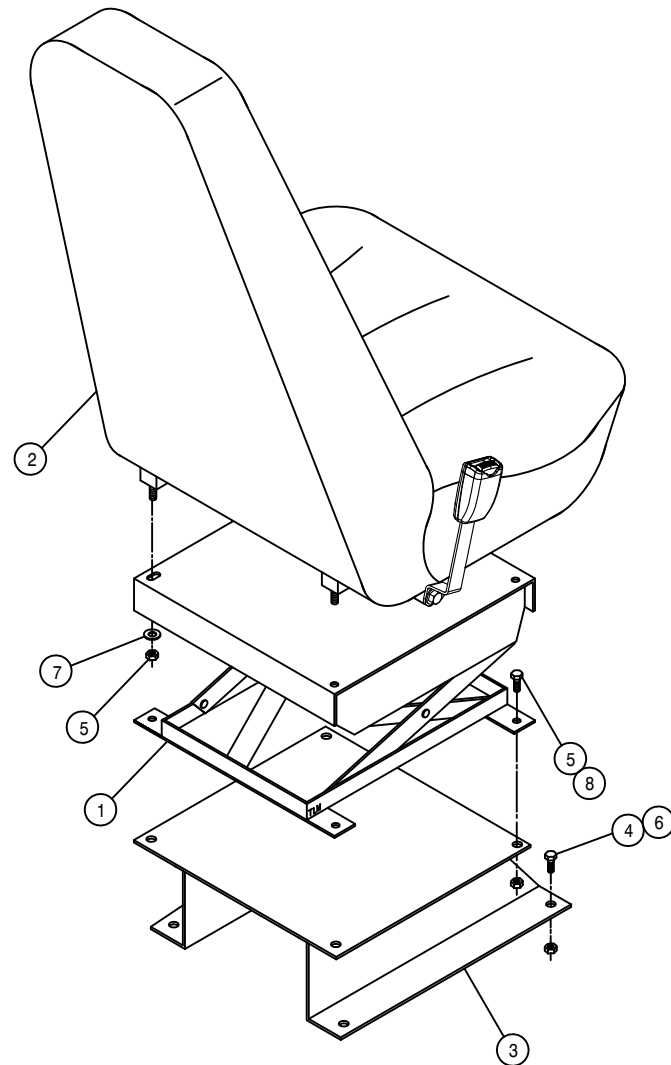

SEAT ASSEMBLY W/O CAB

SEAT ASSEMBLY

DET. QTY PART NO. DESCRIPTION

1	1	330015	SUSPENSION ASSY TRIMLINE SEAT
2	1	330043	SEAT,EVC MIDHIGH TRIMLINE (CE)
3	2	341554	SEAT MT WLD TRIMLINE SEAT
4	8	900129	3/8UNC X 1" SERR FLANGE BOLT
5	12	914002	5/16UNC HEX STOVER NUT
6	8	914004	3/8UNC HEX STOVER NUT
7	2	920001	5/16 SAE FLAT WASHER
8	4	900064	5/16UNC X 3/4 HEX BOLT
9	1	330044	SEAT, (FOR 204SP CAB) (CE)
10	1	330024	HEIGHT ADJ LATCH, SEAT 330022
11	1	330025	ADJ LATCH SPRING, SEAT 330022
12	1	330023	AIR BAG PKG, SEAT 330022

STEERING POST ASSEMBLY

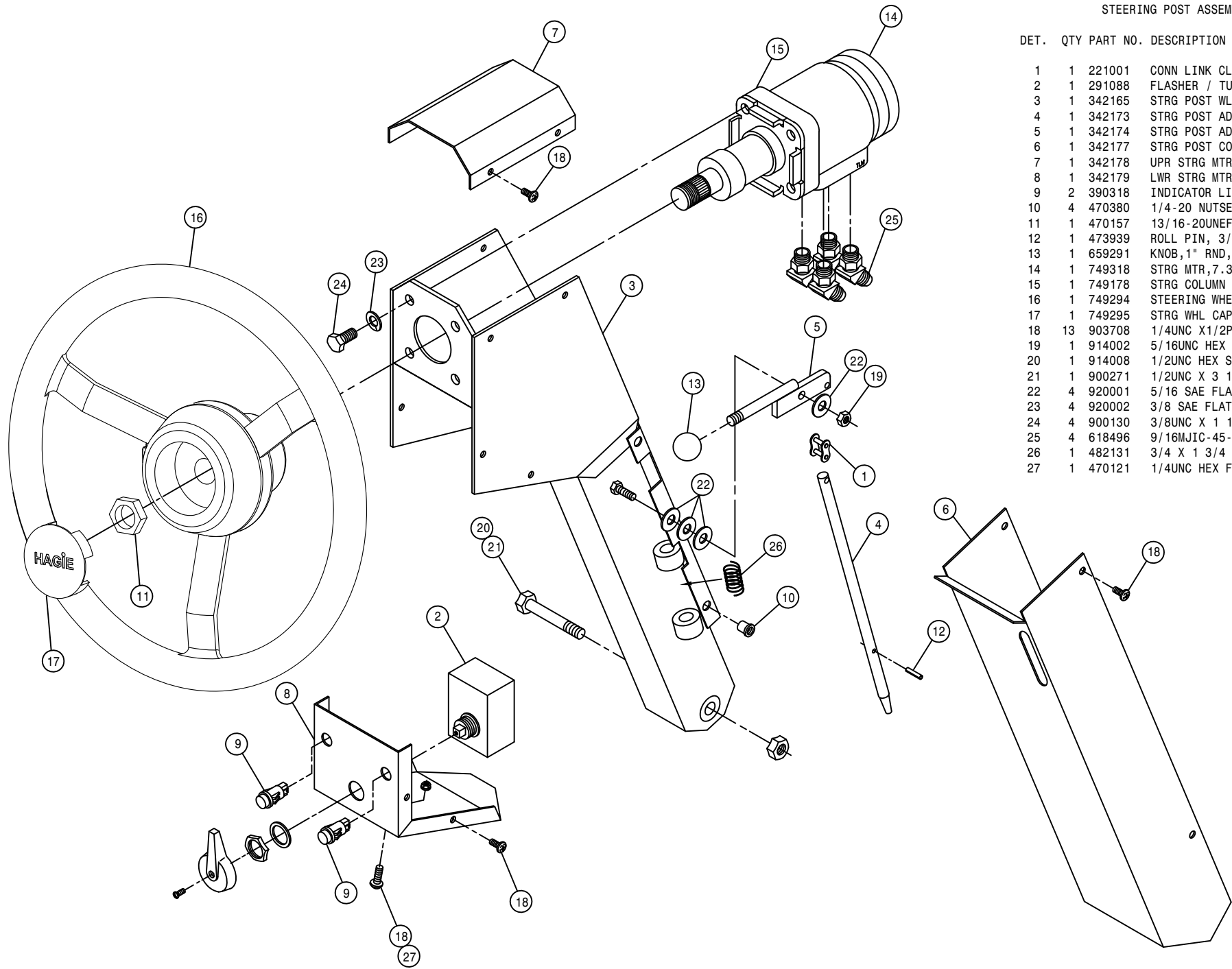

DET.	QTY	PART NO.	DESCRIPTION
1	1	221001	CONN LINK CLIP TYPE RC50
2	1	291088	FLASHER / TURN SIGNAL SWITCH
3	1	342165	STRG POST WLD, 284 CAB 94
4	1	342173	STRG POST ADJ PIN, 284 CAB 94
5	1	342174	STRG POST ADJ PIN LEVER WLD94
6	1	342177	STRG POST COVER, 284 CAB 94
7	1	342178	UPR STRG MTR HSNQ COVER 94
8	1	342179	LWR STRG MTR HSNQ COVER 94
9	2	390318	INDICATOR LIGHT, RED
10	4	470380	1/4-20 NUTSERT .027-.165 STL
11	1	470157	13/16-20UNEF HEX NUT STRG WHL
12	1	473939	ROLL PIN, 3/16 X 7/8
13	1	659291	KNOB,1" RND,BLK, 3/8-16
14	1	749318	STRG MTR,7.3CID,NON-LOAD 1031
15	1	749178	STRG COLUMN 2.5IN LONG
16	1	749294	STEERING WHEEL, VIP 14"
17	1	749295	STRG WHL CAP WITH 'H' EMBLEM
18	13	903708	1/4UNC X1/2PHIL PANHD MACH SCR
19	1	914002	5/16UNC HEX STOVER NUT
20	1	914008	1/2UNC HEX STOVER NUT
21	1	900271	1/2UNC X 3 1/4 HEX BOLT
22	4	920001	5/16 SAE FLAT WASHER
23	4	920002	3/8 SAE FLAT WASHER
24	4	900130	3/8UNC X 1 1/4 SER FLANGE BOLT
25	4	618496	9/16MJIC-45-3/4MOR LBO
26	1	482131	3/4 X 1 3/4 COMPRSN SPRING
27	1	470121	1/4UNC HEX FLANGE LOCK NUT

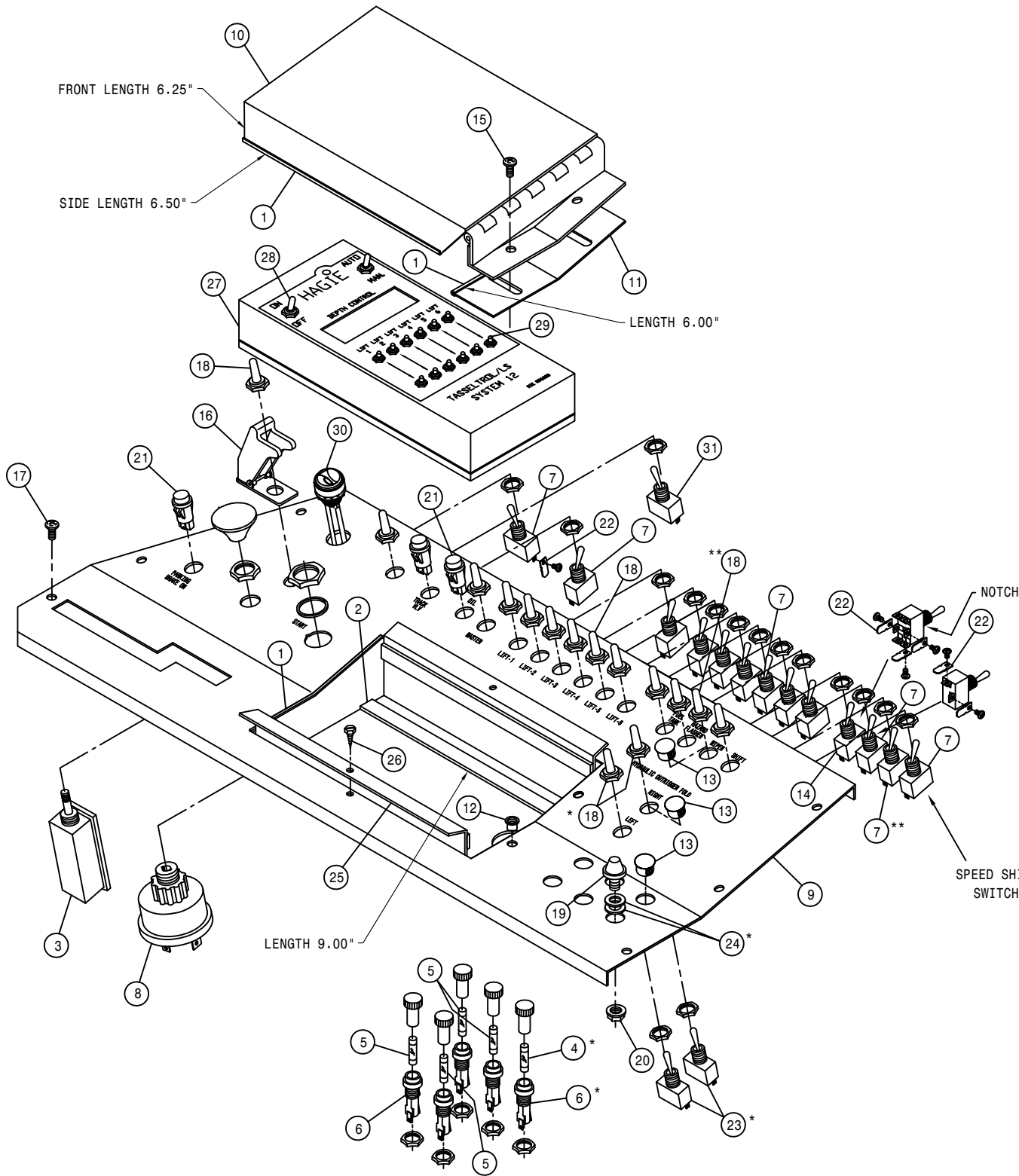

CONSOLE PANEL ASSEMBLY

DET.	QTY	PART NO.	DESCRIPTION
1	3	193011	EDGE GUARD, BLK
2	2	193037	STICKERTITE 1/8 X 3/4
3	1	290074	LIGHT SWITCH
4	1	291602	FUSE,AGC,10A GLASS
5	4	298004	FUSE,AGC,20 AMP GLASS
6	5	298011	FUSE HOLDER
7	11	298012	TOGGLE SWITCH,ON-OFF,SPST,15A
8	1	290073	IGN SWITCH, SEALED 4 POSITION
9	1	343763	CONSOLE PANEL, 204SP
10	1	342240	CONTROL BOX COVER WLD, 204
11	1	342244	CONTROL BOX KEEPER, 204
12	2	470384	OBS>: 10-32 NUTSERT .020-.130
13	4	470224	SNAP PLUG, BLK NYL, .50 DIA
14	1	610412	TOGGLE SWITCH FOR FUEL VLV
15	2	903710	10-32X5/8 PHIL PANHD MACH SCR
16	1	291655	AIRCRAFT TOGGLE SWITCH GUARD
17	6	903708	1/4UNC X1/2PHIL PANHD MACH SCR
18	14	470001	RUBBER BOOT W NUT FOR 298012
19	1	470230	1/2 RUBBER BUMPER,1/4-20 STUD
20	1	470121	1/4UNC SER FLG LOCK NUT
21	3	390318	INDICATOR LIGHT, RED
22	6	291644	.250MALE FASTON-#6 RING ADPTR
23	2	293038	TOGGLE SWITCH DPDT 15 AMP
24	2	920002	3/8 SAE FLAT WASHER
25	1	342297	LS CTRL 6L DISPLAY BOX MT
26	2	473902	#8 X 1/2 PHIL PAN HD MTL SCR
27	1	293373	LS CTRL 6L DISPLAY BOX ASSY
28	2	470001	RUBBER BOOT W NUT FOR 298012
29	12	293255	SWITCH BOOT,PUSHBUTTON,1/4-40
30	1	292504	HORN SWITCH ASSY
31	1	292560	SWITCH,TOGGLE,MO ON-OFF-MO ON

NOTE: ITEMS WITH (*) ARE USED WITH THE OUTRIGGER FOLD OPTION.
 ITEMS WITH (**) ARE USED WITH THE WINDSHIELD WIPER IN THE CAB OPTION.

30

488030

CONSOLE ASSEMBLY

DET.	QTY	PART NO.	DESCRIPTION
1	1	293093	TERMINAL BLOCK 6 POS - 2 ROW
2	1	342248	CONSOLE BRACE, 204 94
3	1	342216	DRINK HOLDER MT BRKT 94
4	8	470380	1/4-20 NUTSERT .027-.165 STL
5	4	470175	10-32 HEX FLANGE LOCK NUT
6	1	470214	SPILLMASTER DRINK HOLDER
7	1	291197	CIRCUIT BREAKER,30AMP,INLINEMT
8	1	343764	CONSOLE WLD, 204SP '10
9	1	343769	BACK UP SIG BRKT, 204SP
10	7	470121	1/4UNC HEX FLANGE LOCK NUT
11	3	470118	1/4UNC X 3/4 FLANGE HEX BOLT
12	4	903710	10-32X5/8 PHIL PANHD MACH SCR
13	2	903812	6-32 X 1/2 PHIL PAN MACH SCR
14	4	903814	6-32 X 3/4 PHIL PAN MACH SCR
15	6	910022	6-32 HEX NUT
16	1	910024	8-32 HEX NUT
17	1	900004	1/4UNC X 1 1/4 HEX BOLT
18	1	291640	RELAY, 12V 20/30AMP BOSCH
19	1	903844	8-32 X 1/2 PHIL PANHD MACH SCR
20	3	903808	6-32 X 3/8 PHIL PANHD MACH SCR
21	1	920000	1/4 SAE FLAT WASHER
22	1	290064	SWITCH,BACK-UP
23	1	290065	TIMER BLOCK
24	1	290070	RELAY
25	1	294005	POWER RELAY ASSY 204SP '10
26	2	470122	1/4UNC X 1/2 FLANGE HEX BOLT
27	2	470384	10-32 NUTSERT .020-.130 STL
28	1	903703	1/4UNC X 2" PHIL PAN MACH SCR
29	1	903724	1/4UNC X 1 1/4 PHIL PAN MACH SCR
30	2	903883	10-32 X 1/2 PHIL PAN MACH SCR

NOTE: ITEMS MARKED WITH A (*) ARE USED WITH THE CAB OPTION.

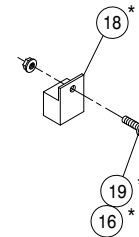
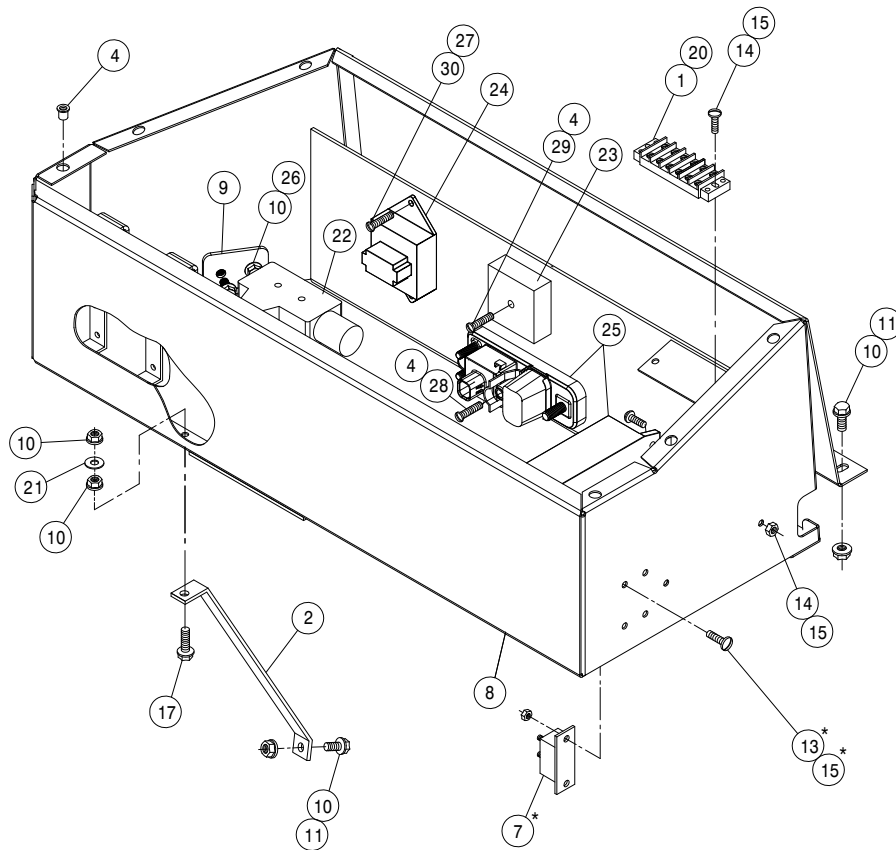
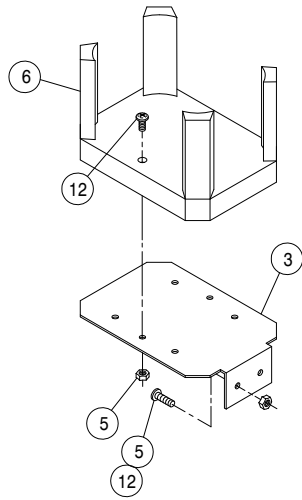

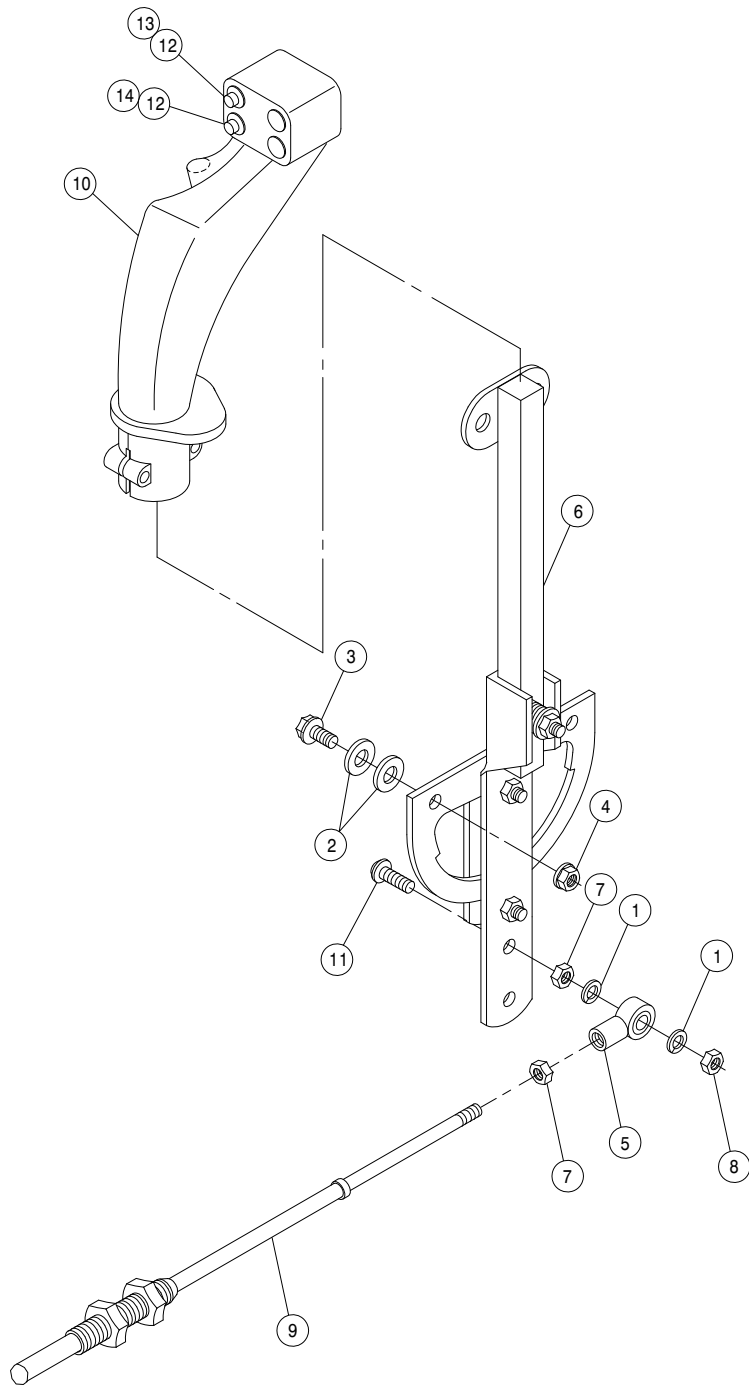

HYDROSTATIC LEVER ASSEMBLY

DET. QTY PART NO. DESCRIPTION

1	2	920510	#10 LOCK WASHER
2	4	920000	1/4 SAE FLAT WASHER
3	2	470118	1/4UNC X 3/4 FLANGE HEX BOLT
4	2	470121	1/4UNC HEX FLANGE LOCK NUT
5	1	473921	BALL JOINT NO 10-32 THD
6	1	606907	HYDST CTRL LEVER ASSY 204-284
7	2	910027	10-32 HEX NUT
8	1	914027	10-32 HEX STOVER NUT
9	1	785003	CTRL CABLE 10-32 4IN X 112 LG
10	1	785077	FASSE EZ-3 CONTROL HANDLE,204
11	1	903893	10-32 X 1" SLT RD HD MACH SCR
12	2	291650	SWITCH,SPDT MOM MICRO
13	1	291652	SWITCH BOOT, RED -FOR 291650
14	1	291682	SWITCH BOOT, GRN -FOR 291650

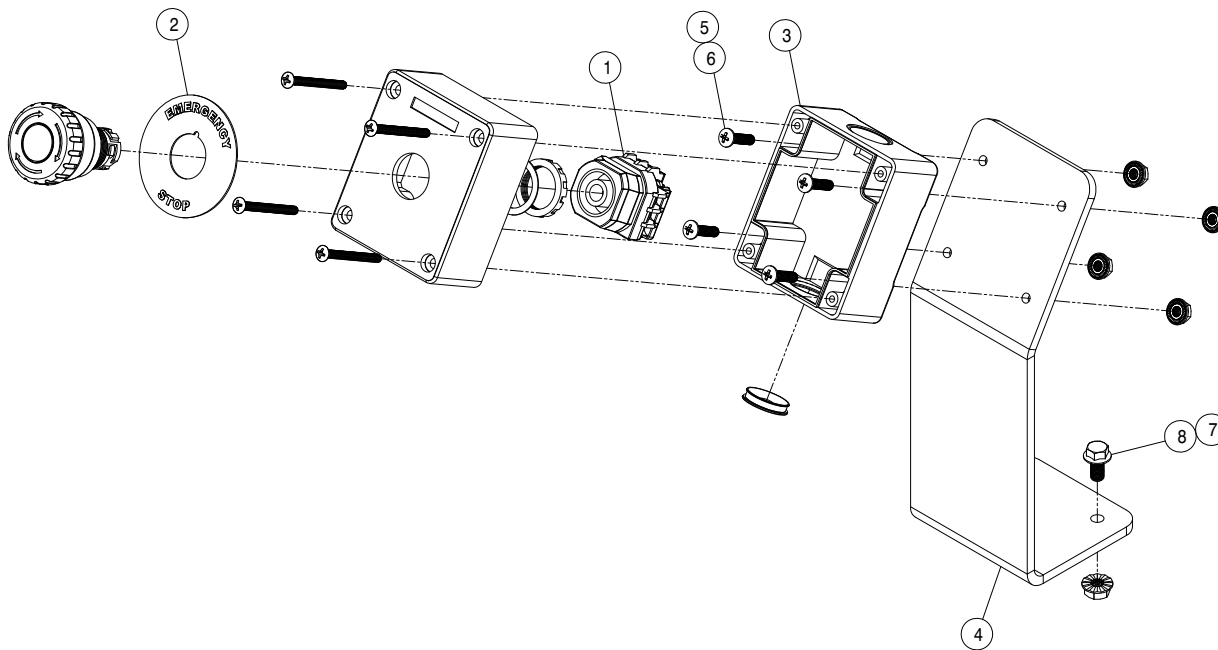

E-STOP SWITCH ASSEMBLY

DET. QTY PART NO. DESCRIPTION

1	1	290056	E-STOP SWITCH,LED DPST-2NC
2	1	290057	EMERGENCY STOP DISC FOR 290056
3	1	290058	SWITCH ENCLOSURE,1-STN
4	1	343761	E-STOP BRACKET, 204SP '10
5	4	470175	10-32 HEX FLANGE LOCK NUT
6	4	472235	10-32 X 3/4 PHIL HD MACH SCR
7	2	470121	1/4UNC HEX FLANGE LOCK NUT
8	2	470122	1/4UNC X 1/2 FLANGE HEX BOLT

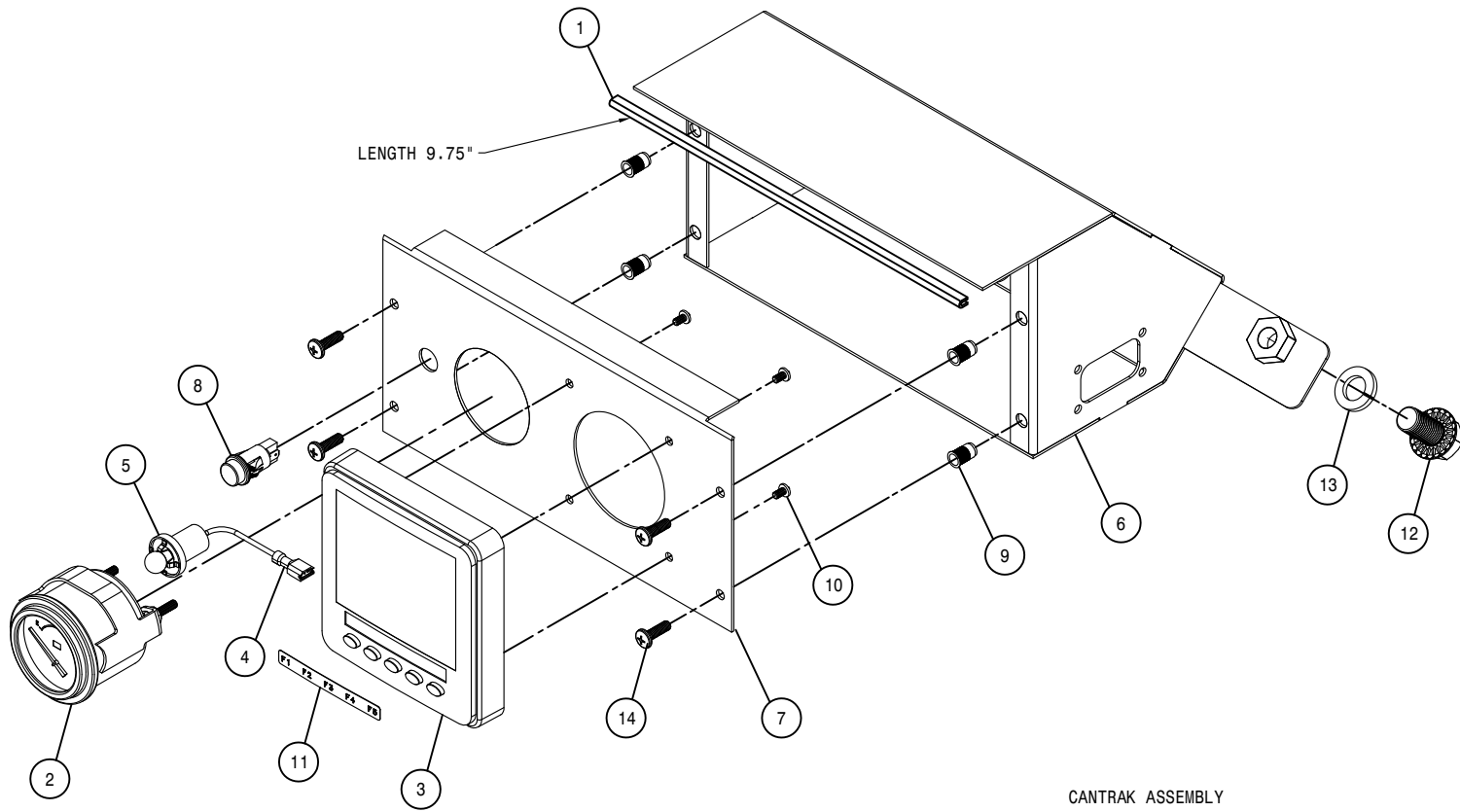

CANTRAK ASSEMBLY

DET.	QTY	PART NO.	DESCRIPTION
	1	193011	EDGE GUARD, BLK
	1	290401	FUEL GAUGE FOR 2.125 DIA HOLE
	1	291349	CANTRAK 2600 DISPLAY
	1	291571	TYCO,FASTON, .250(16-14GA),FEM
	1	291612	LIGHT KIT FOR 2" GAUGE
	1	343801	CANTRAK HSNGL WLD, 204SP
	1	343802	CANTRAK PANEL, 204SP
	1	390318	INDICATOR LIGHT, RED
	4	470384	10-32 NUTSERT .020-.130 STL
	4	903804	6-32 X 1/4 PHIL PAN MACH SCR
	1	650270	DECAL,CANTRAK FUNCTION KEY
	2	900263	1/2UNC X 1" HEX BOLT
	2	920504	1/2 LOCK WASHER
	4	903710	10-32X5/8 PHIL PANHD MACH SCR

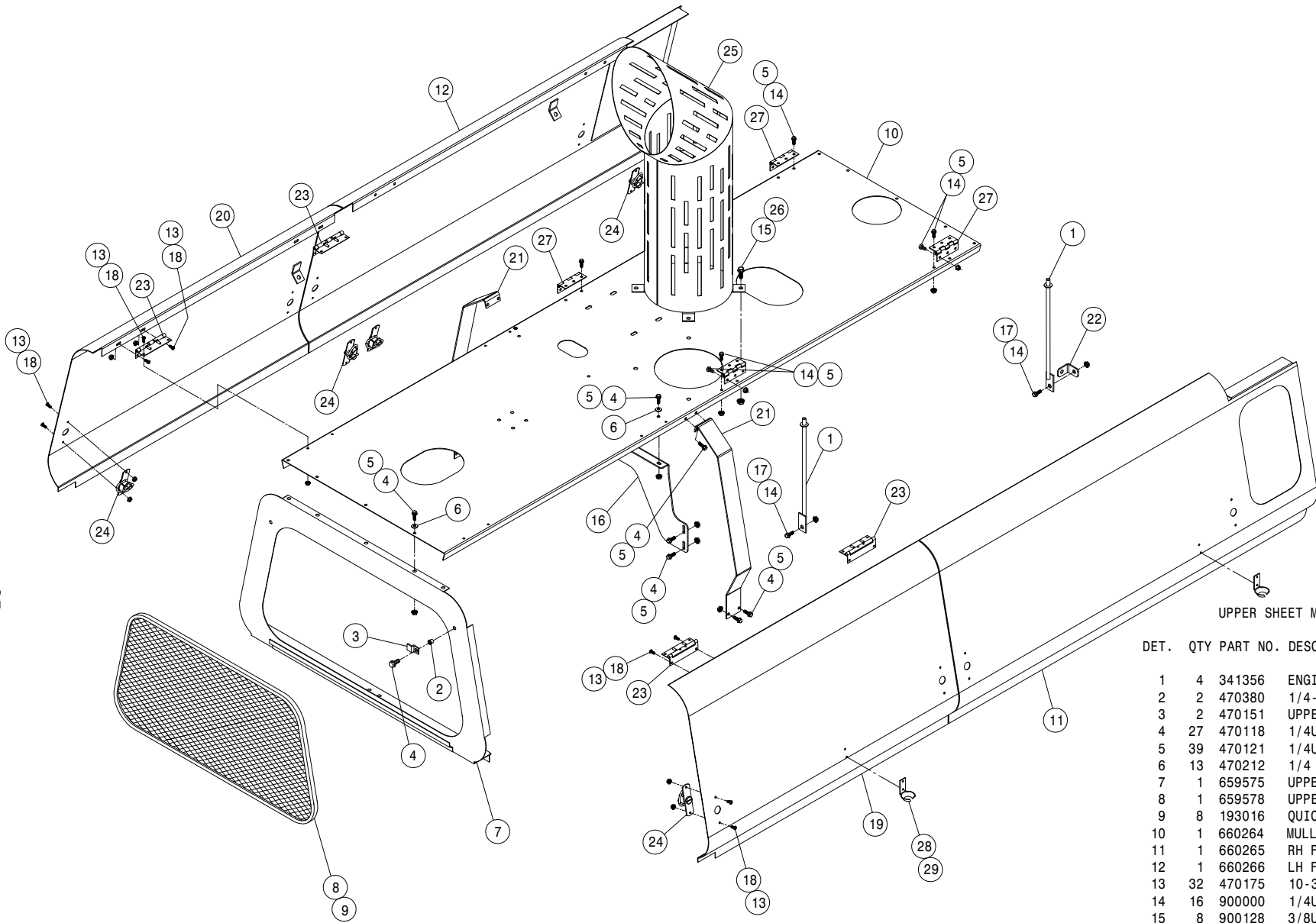

UPPER SHEET METAL ASSEMBLY

DET.	QTY	PART NO.	DESCRIPTION
1	4	341356	ENGINE HOOD PROP WLD 8240 82
2	2	470380	1/4-20 NUTSERT .027-.165 STL
3	2	470151	UPPER REAR PANEL SCREEN CLIP
4	27	470118	1/4UNC X 3/4 FLANGE HEX BOLT
5	39	470121	1/4UNC HEX FLANGE LOCK NUT
6	13	470212	1/4 BONDED SEALING WASH, SS
7	1	659575	UPPER REAR PANEL WLD 8240 82
8	1	659578	UPPER REAR PANEL SCREEN 8240
9	8	193016	QUICKEDGE TRIM .060 TO .170
10	1	660264	MULLION, 204SP '11
11	1	660265	RH FRT ENG HOOD WLD,204SP '11
12	1	660266	LH FRT ENG HOOD WLD,204SP '11
13	32	470175	10-32 HEX FLANGE LOCK NUT
14	16	900000	1/4UNC X 1/2 HEX BOLT
15	8	900128	3/8UNC X 3/4 HEX BOLT
16	1	660276	MULLION SUPPORT,204SP '10
17	4	914004	3/8UNC HEX STOVER NUT
18	32	903883	10-32 X 1/2 PHIL PAN MACH SCR
19	1	660267	RH REAR HOOD WLD,204SP '11
20	1	660269	RH FRT ENG HOOD,204SP '11
21	2	660273	204 CE HOOD CENTER BRACE '11
22	2	660275	FRT HOOD PROP MR,204SP '11
23	4	660282	HINGE,4" QUICK-DISCONCT W/.218
24	8	470574	LATCH,SPRING COMPRESSION,LARGE
25	1	343970	MUFFLER GUARD ASSY 204SP'12
26	4	470087	3/8UNC HEX FLANGE LOCK NUT
27	1	344106	HINGE,3"LG x 2"W, STX
28	8	485053	POP RIVET 3/16 X 3/8
29	4	656997	RUBBER HOOK BRKT

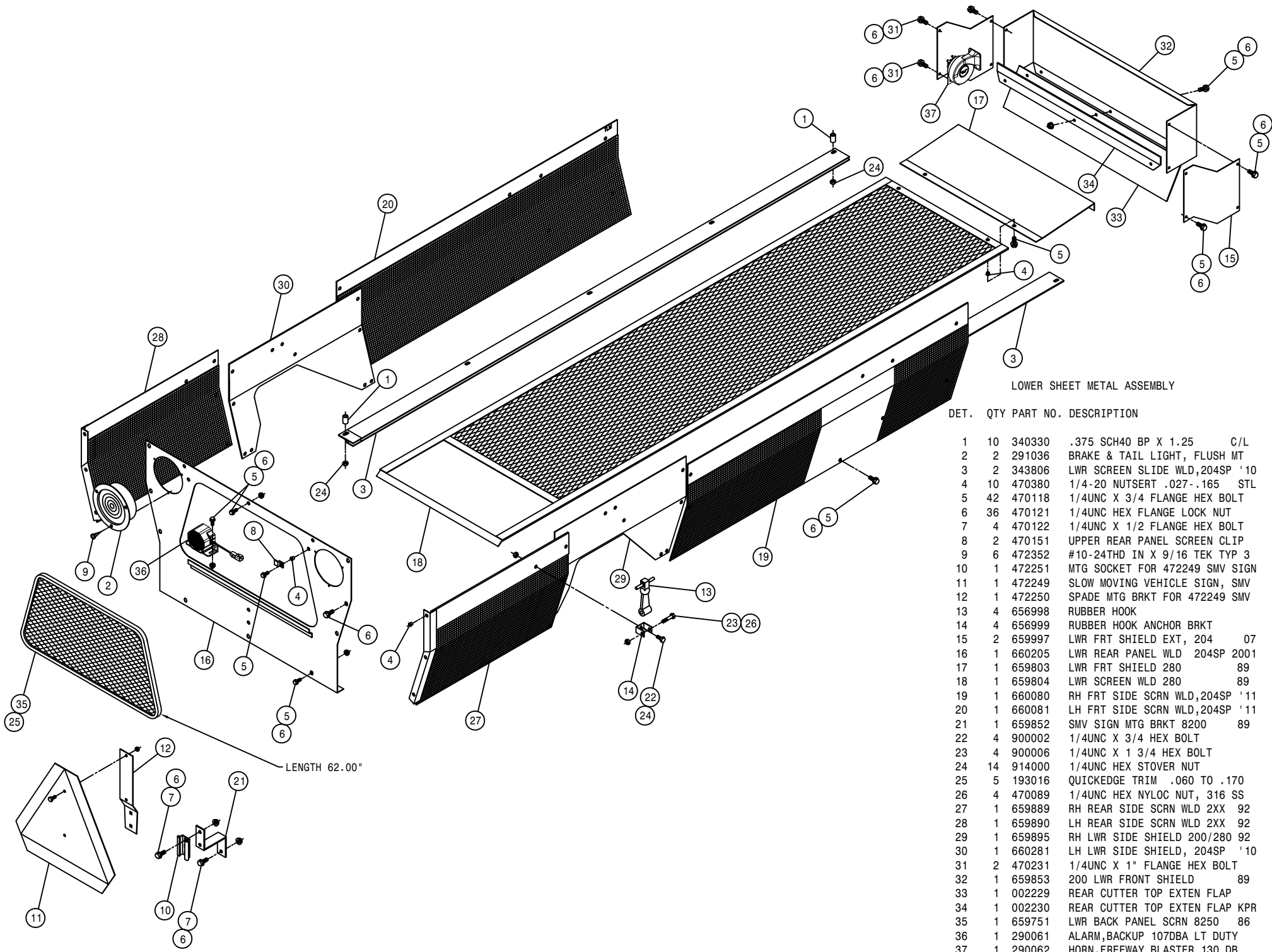

LOWER SHEET METAL ASSEMBLY

DET.	QTY	PART NO.	DESCRIPTION
1	10	340330	.375 SCH40 BP X 1.25 C/L
2	2	291036	BRAKE & TAIL LIGHT, FLUSH MT
3	2	343806	LWR SCREEN SLIDE WLD,204SP '10
4	10	470380	1/4-20 NUTSERT .027-.165 STL
5	42	470118	1/4UNC X 3/4 FLANGE HEX BOLT
6	36	470121	1/4UNC HEX FLANGE LOCK NUT
7	4	470122	1/4UNC X 1/2 FLANGE HEX BOLT
8	2	470151	UPPER REAR PANEL SCREEN CLIP
9	6	472352	#10-24THD IN X 9/16 TEK TYP 3
10	1	472251	MTG SOCKET FOR 472249 SMV SIGN
11	1	472249	SLOW MOVING VEHICLE SIGN, SMV
12	1	472250	SPADE MTG BRKT FOR 472249 SMV
13	4	656998	RUBBER HOOK
14	4	656999	RUBBER HOOK ANCHOR BRKT
15	2	659997	LWR FRT SHIELD EXT, 204 07
16	1	660205	LWR REAR PANEL WLD 204SP 2001
17	1	659803	LWR FRT SHIELD 280 89
18	1	659804	LWR SCREEN WLD 280 89
19	1	660080	RH FRT SIDE SCR N WLD,204SP '11
20	1	660081	LH FRT SIDE SCR N WLD,204SP '11
21	1	659852	SMV SIGN MTG BRKT 8200 89
22	4	900002	1/4UNC X 3/4 HEX BOLT
23	4	900006	1/4UNC X 1 3/4 HEX BOLT
24	14	914000	1/4UNC HEX STOVER NUT
25	5	193016	QUICKEDGE TRIM .060 TO .170
26	4	470089	1/4UNC HEX NYLOC NUT, 316 SS
27	1	659889	RH REAR SIDE SCR N WLD 2XX 92
28	1	659890	LH REAR SIDE SCR N WLD 2XX 92
29	1	659895	RH LWR SIDE SHIELD 200/280 92
30	1	660281	LH LWR SIDE SHIELD, 204SP '10
31	2	470231	1/4UNC X 1" FLANGE HEX BOLT
32	1	659853	200 LWR FRONT SHIELD 89
33	1	002229	REAR CUTTER TOP EXTEN FLAP
34	1	002230	REAR CUTTER TOP EXTEN FLAP KPR
35	1	659751	LWR BACK PANEL SCR N 8250 86
36	1	290061	ALARM, BACKUP 107DBA LT DUTY
37	1	290062	HORN, FREEWAY BLASTER 130 DB

LENGTH 62.00"

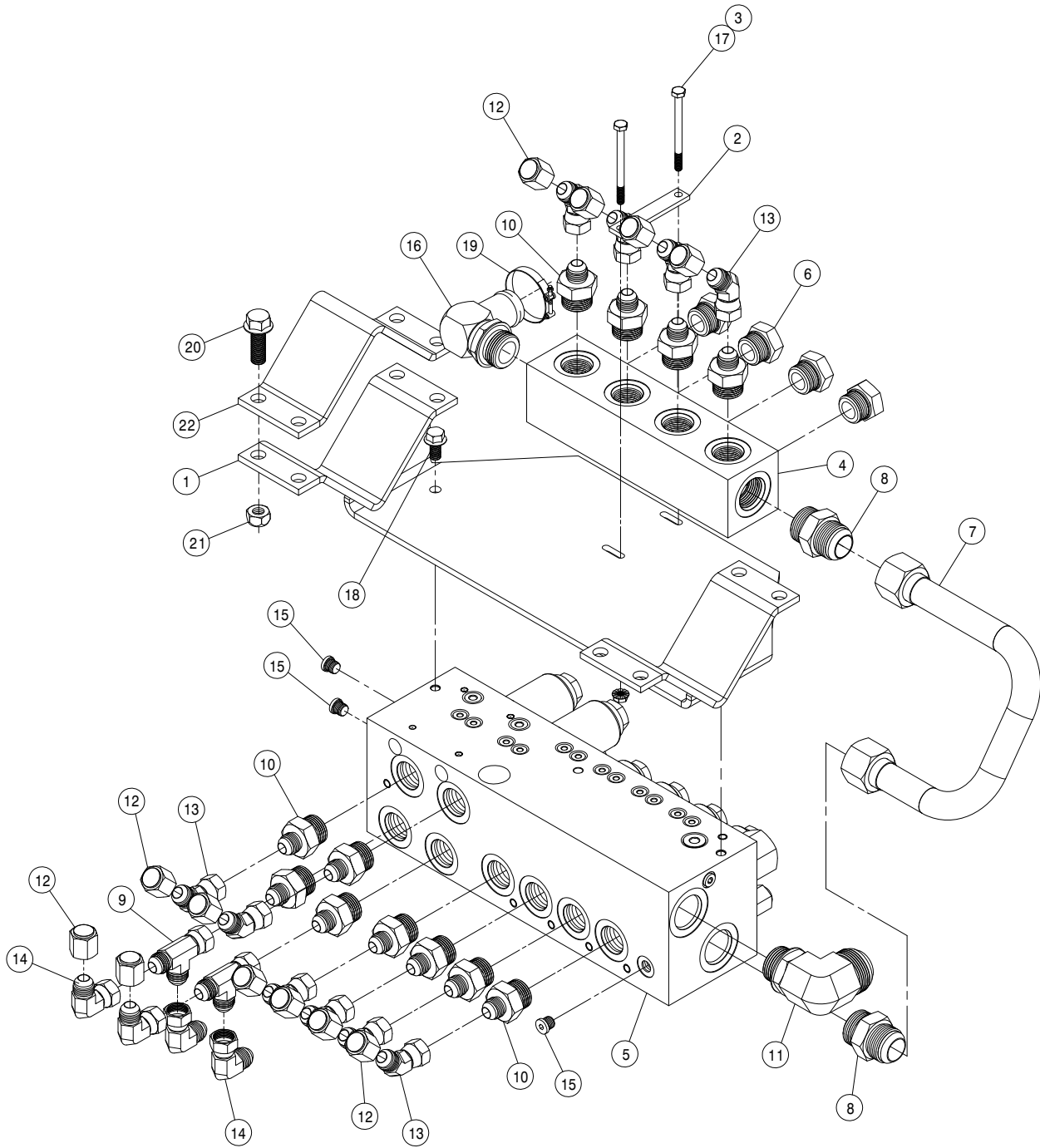

MOTOR CONTROL VALVE ASSEMBLY

DET. QTY PART NO. DESCRIPTION

1	1	439114	MTR CTRL VLV MT WLD, 204	07
2	1	439116	MTR CTRL VLV MT KEEPER, 204	07
3	2	470121	1/4UNC HEX FLANGE LOCK NUT	
4	1	606029	RETURN MANIFOLD BLOCK, STS	03
5	1	606262	MTR CONTROL ELECT VLV, SAUER	07
6	4	610186	1 1/16MOR PLUG, HEX HEAD	
7	1	615799	MTR CTRL RET TUBE ASSY, 204	07
8	2	618186	1 5/16MJIC-1 5/16MOR ADPTR	
9	2	618451	3/4FJIC SW RUN TEE-3/4MJIC	
10	12	618469	3/4MJIC-1 1/16MOR ADPTR	
11	1	618476	1 5/8MJIC-90-1 5/16MOR LBO	
12	12	618532	3/4FJIC CAP NUT	
13	10	618590	3/4MJIC-45-3/4FJIC SWIV LBO	
14	4	618609	3/4MJIC-90-3/4FJIC SWIV LBO	
15	3	618753	7/16MOR PLUG, HEX SOCKET	
16	1	618772	1 1/4 HOSE BARB-90-1 5/16MOR	
17	2	900011	1/4UNC X 3 1/4 HEX BOLT	
18	2	900128	3/8UNC X 3/4 HEX BOLT	
19	1	520132	1.62/1.87 T-BOLT HOSE CLAMP SS	
20	8	900265	1/2UNC X 1 1/2 HEX BOLT	
21	8	914008	1/2UNC HEX STOVER NUT	
22	2	438324	75IN OUTRGR BRACE CLAMP	

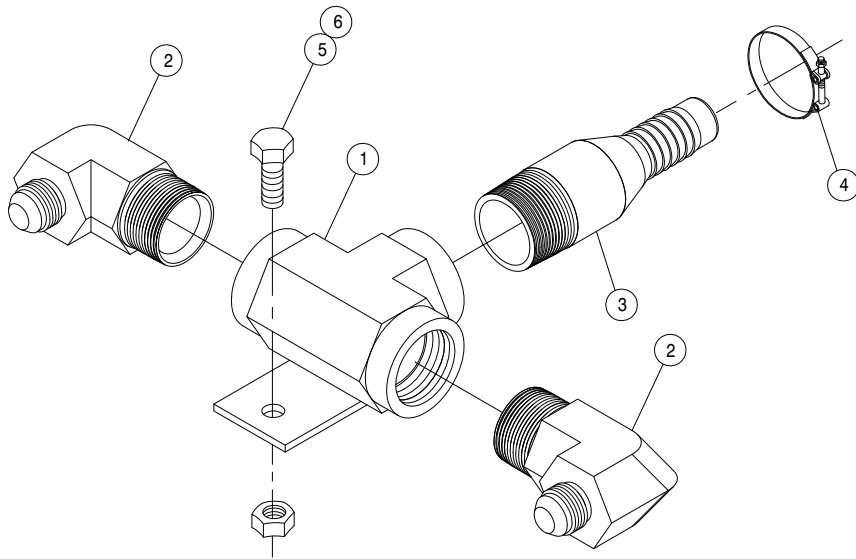

RETURN TEE ASSEMBLY

DET.	QTY	PART NO.	DESCRIPTION	
1	1	614660	1IN STL TEE WLD 280	89
2	2	618714	3/4MJIC-90-1"MNPT LBO	
3	1	714331	1 NPT X 3/4 HOSE BARB	
4	1	520154	1.06/1.19 T-BOLT HOSE CLAMP SS	
5	1	900128	3/8UNC X 3/4 HEX BOLT	
6	1	914004	3/8UNC HEX STOVER NUT	

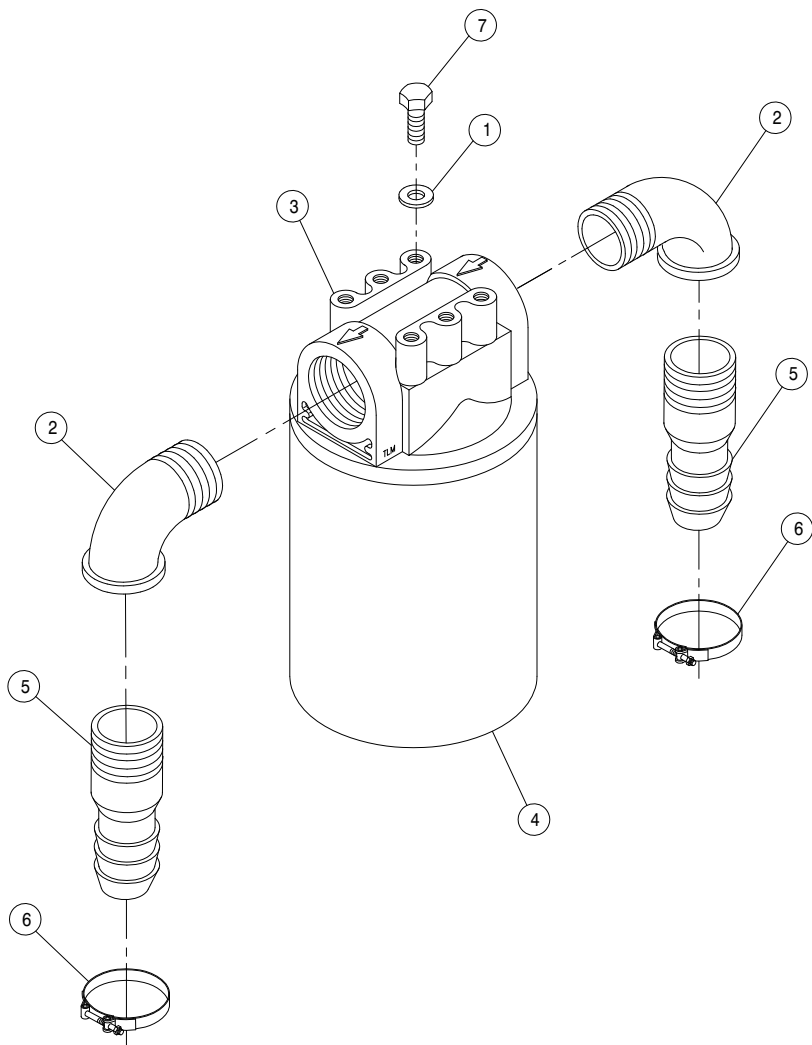

DETASSELER FILTER ASSEMBLY

DET. QTY PART NO. DESCRIPTION

1	4	920501	5/16 LOCK WASHER
2	2	506410	BLK PIPE ST EL 90DEG 1.25NPT
3	1	605633	PARKER FILTER ASSY,25M,1.25NPT
4	1	605634	PARKER FILTER ELEMENT,25MICRON
5	2	715660	HOSE BARB 1 1/4NPT X 1 1/4
6	2	520132	1.62/1.87 T-BOLT HOSE CLAMP SS
7	4	900062	5/16UNC X 1/2 HEX BOLT

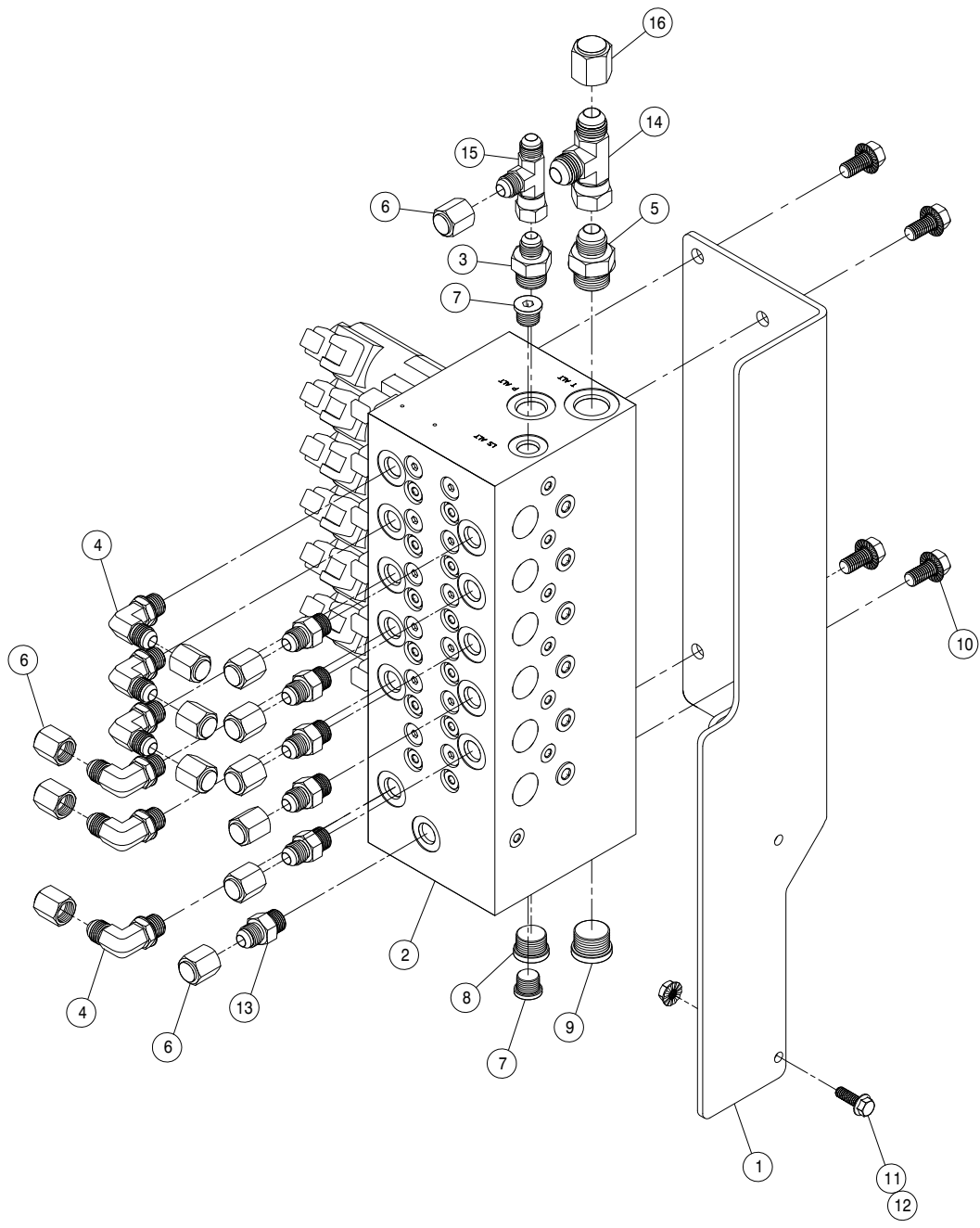

LIFT VALVE ASSEMBLY

DET.	QTY	PART NO.	DESCRIPTION
	1	003101	LIFT VALVE MT WLD 204 08
	1	606285	LIFT VALVE,STS COMBO,SAUER
	1	618109	9/16MJIC-3/4MOR ADPTR
	6	618119	9/16MJIC-90-9/16MOR LBO
	1	618327	3/4MJIC-7/8MOR ADPTR
	13	618531	9/16FJIC CAP NUT
	2	618754	9/16MOR PLUG, HEX SOCKET
	1	618755	3/4MOR PLUG, HEX SOCKET
	1	618756	7/8MOR PLUG, HEX SOCKET
	4	900128	3/8UNC X 3/4 HEX BOLT
	3	470118	1/4UNC X 3/4 FLANGE HEX BOLT
	3	470121	1/4UNC HEX FLANGE LOCK NUT
	1	618126	9/16MJIC-9/16MOR ADPTR
	1	618451	3/4FJIC SW RUN TEE-3/4MJIC
	1	618486	9/16FJIC SW RUN TEE-9/16MJIC
	1	618532	3/4FJIC CAP NUT

DUMP MANIFOLD VALVE ASSEMBLY

DET. QTY PART NO. DESCRIPTION

1	1	003100	DUMP VALVE MT 204 08
2	2	470460	3/8 X 1 SERR FLANGE BOLT
3	1	605615	HYD FILTER, INLINE 25M 9/16FOR
4	1	606330	DUMP MANIF VALVE SAUER
5	1	611125	3/4MJIC-3/4MOR ADPTR
6	1	611128	7/8MJIC-90-7/8MOR LBO
7	1	618249	3/4MJIC-90-9/16MOR LBO
8	1	618464	3/4MJIC-90-3/4MOR LG LBO
9	1	618609	3/4MJIC-90-3/4FJIC SWIV LBO
10	1	618692	3/4FJIC SWIV-9/16MOR ADPTR
11	1	618774	7/8MJIC-90-7/8MOR LG LBO
12	2	748501	RUBBER WASH .38 X .406 X 1.50
13	4	470121	1/4UNC HEX FLANGE LOCK NUT
14	4	470118	1/4UNC X 3/4 FLANGE HEX BOLT
15	1	605616	ELEMENT, 25M HYD FILTER 605615
16	1	605617	SPRING KIT, HYD FILTER 605615
17	1	610462	GASKET FOR 610447 ARROW FILT

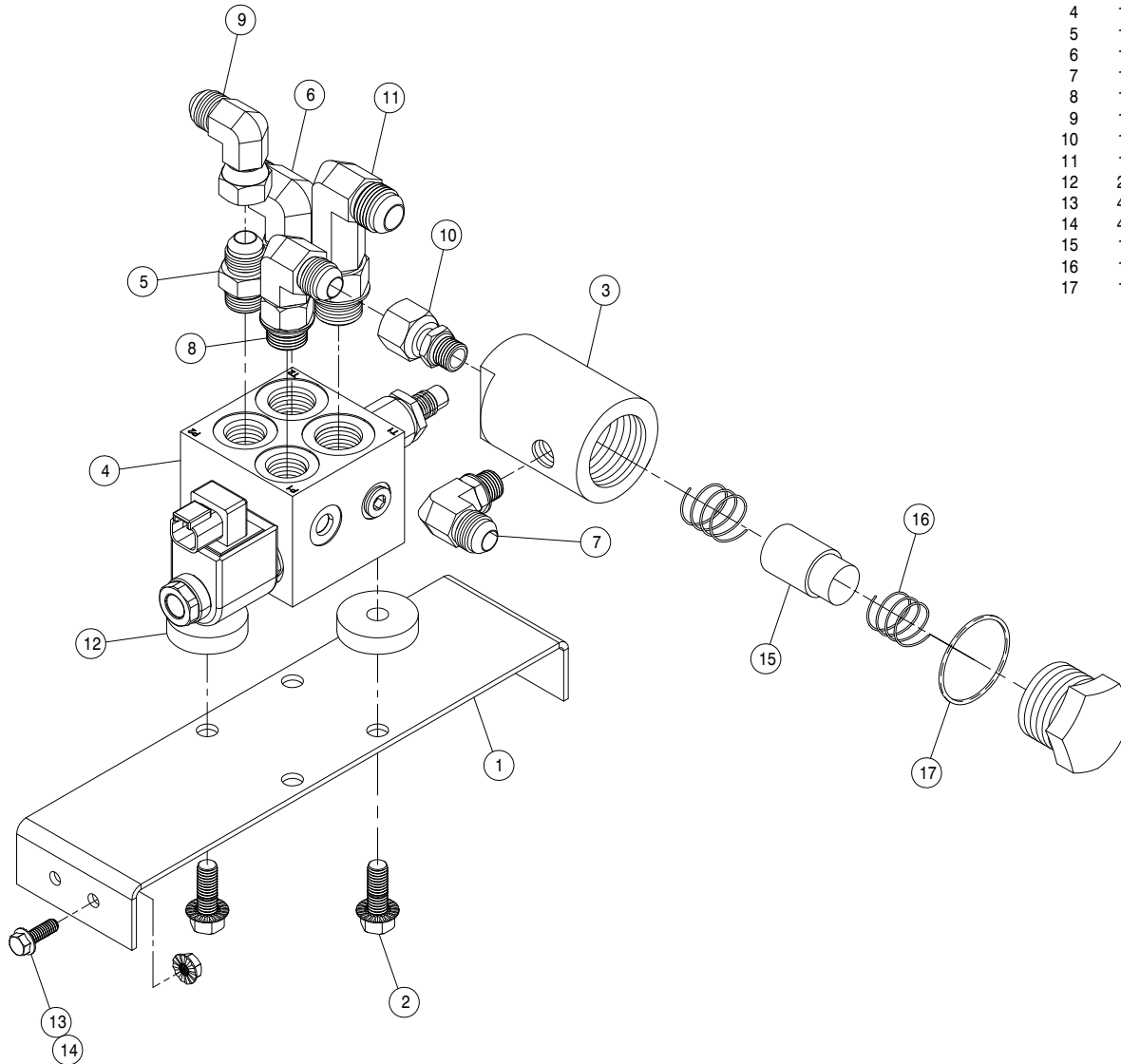

4-ROW, 2-LIFT, OUTRIGGER ASSEMBLY

DET. QTY PART NO. DESCRIPTION

1	1	438530	204 TOOL BAR WLD, 12R 5/6L	96
2	8	900334	5/8UNC X 1 3/4 HEX BOLT	
3	16	914010	5/8UNC HEX STOVER NUT	
4	2	438762	16"HOIST COL ADPTR WLD, 204 04	
5	4	438293	5/8UNC X 6 1/4 CTR U-BOLT TRI	
6	2	438292	TOOL BAR V-PLT WLD 8200	86
7	1	438778	204SPW TOOL BAR WLD	08

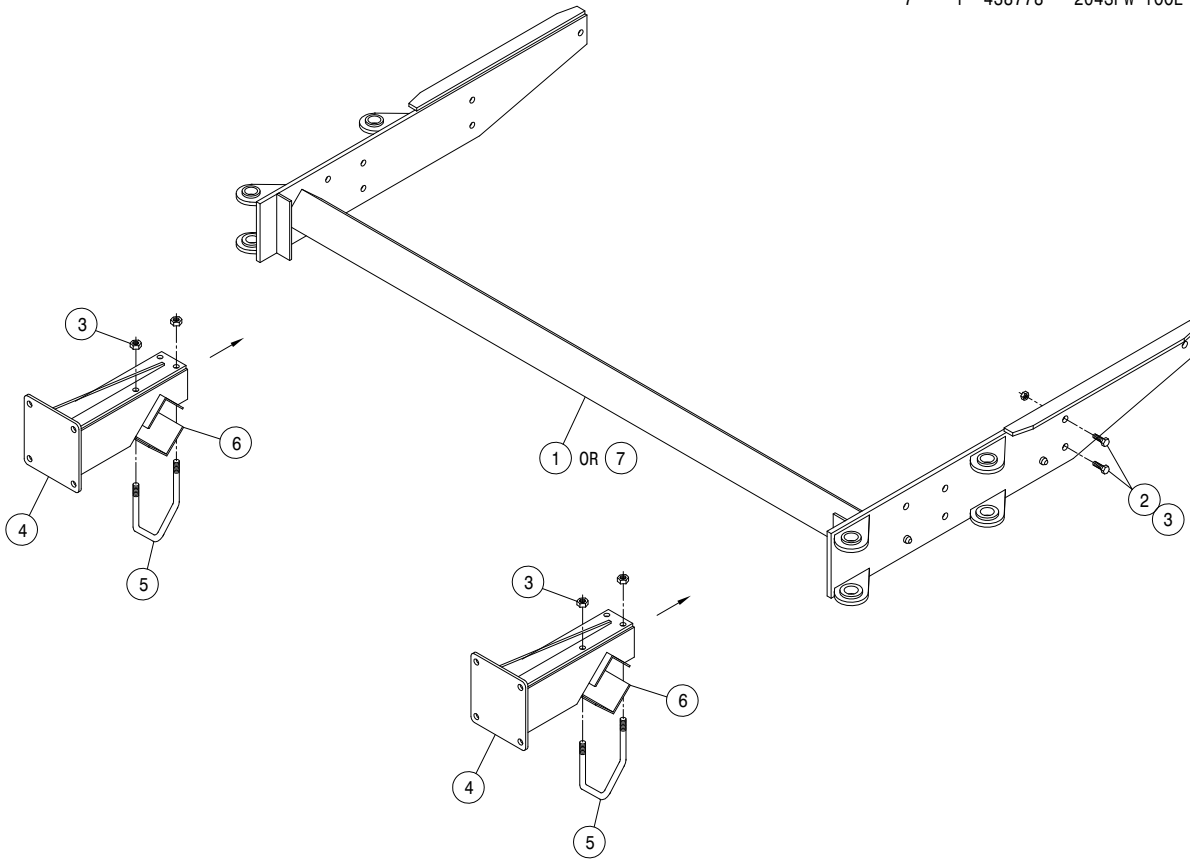

6-ROW, 3-LIFT OUTRIGGER ASSEMBLY

DET. QTY PART NO. DESCRIPTION

DET.	QTY	PART NO.	DESCRIPTION	
1	2	438283	OUTRGR PIVOT PIN WLD 8200	86
2	4	470117	COTTER PIN 3/16 1 3/4 SQ CUT	
3	2	438474	STABILIZER MT PIN WLD 10-12R	
4	1	438277	RH 32IN OUTGR WLD8200-850086	
5	1	438282	LH 32IN OUTGR WLD8200-850086	
6	4	438324	75IN OUTGR BRACE CLAMP	
7	1	438530	204 TOOL BAR WLD, 12R 5/6L	96
8	2	438785	OUTRGR BINDER	
9	4	438397	STABILIZER PIN MT WLD	90
10	4	611016	HAIR PIN #6	
11	16	900265	1/2UNC X 1 1/2 HEX BOLT	
12	8	900334	5/8UNC X 1 3/4 HEX BOLT	
13	20	914010	5/8UNC HEX STOVER NUT	
14	16	914008	1/2UNC HEX STOVER NUT	
15	3	438762	16"HOIST COL ADPTR WLD, 204 04	
16	6	438293	5/8UNC X 6 1/4 CTR U-BOLT TRI	
17	3	438292	TOOL BAR V-PLT WLD 8200	86
18	1	438778	204SPW TOOL BAR WLD	08

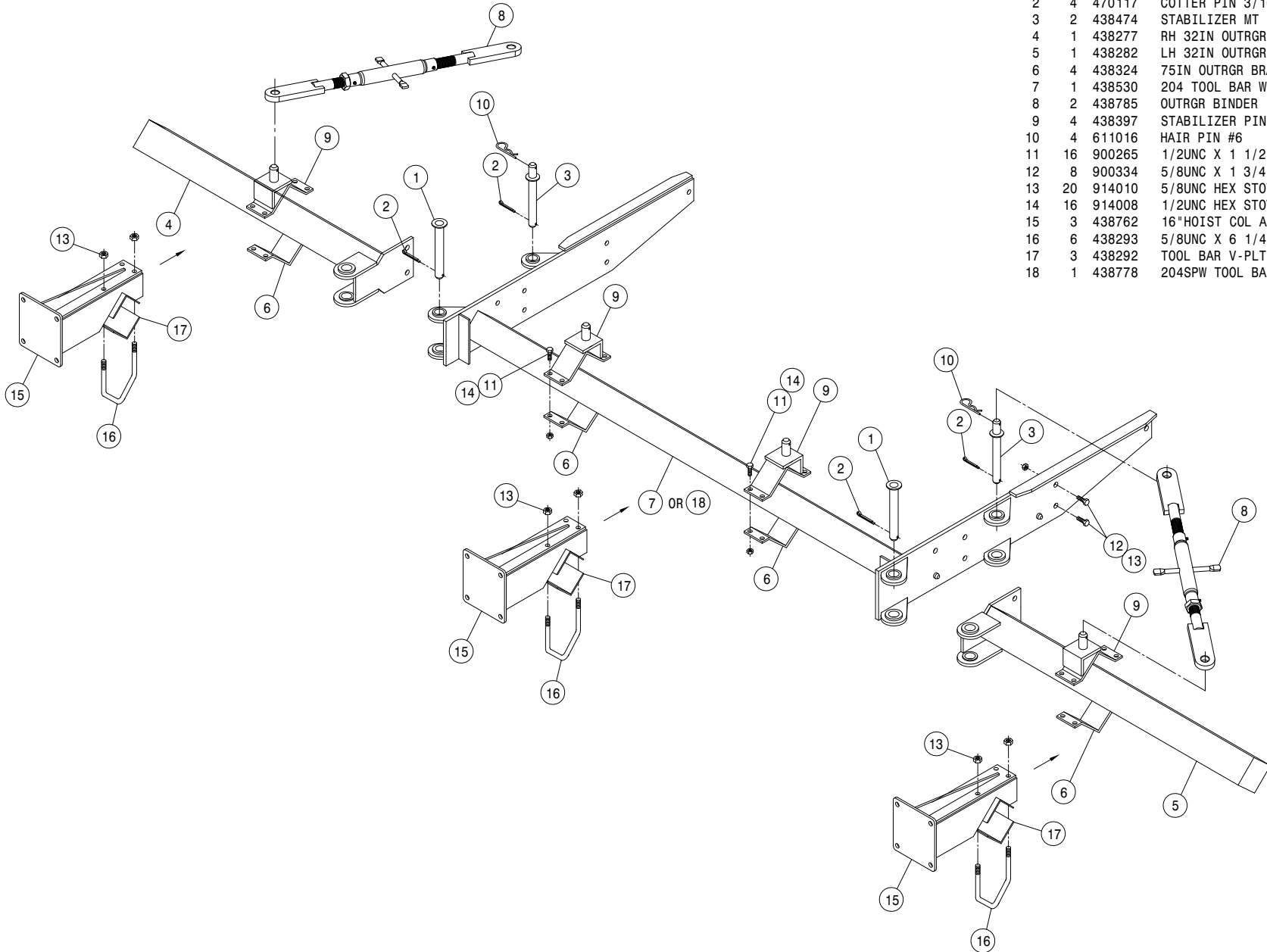

8-ROW, 4-LIFT 20" SPACING OUTRIGGER ASSEMBLY

DET. QTY PART NO. DESCRIPTION

1	1	438283	OUTRGR PIVOT PIN WLD 8200 86
2	2	470117	COTTER PIN 3/16 1 3/4 SQ CUT
3	1	438474	STABILIZER MT PIN WLD 10-12R
4	1	438277	RH 32IN OUTRGR WLD8200-850086
5	2	438757	8" HOIST COL ADPTR WLD, 204 04
6	2	438324	75IN OUTRGR BRACE CLAMP
7	1	438530	204 TOOL BAR WLD, 12R 5/6L 96
8	2	438785	OUTRGR BINDER
9	2	438397	STABILIZER PIN MT WLD 90
10	2	611016	HAIR PIN #6
11	8	900265	1/2UNC X 1 1/2 HEX BOLT
12	8	900334	5/8UNC X 1 3/4 HEX BOLT
13	24	914010	5/8UNC HEX STOVER NUT
14	8	914008	1/2UNC HEX STOVER NUT
15	2	438762	16"HOIST COL ADPTR WLD, 204 04
16	8	438293	5/8UNC X 6 1/4 CTR U-BOLT TRI
17	4	438292	TOOL BAR V-PLT WLD 8200 86
18	1	438778	204SPW TOOL BAR WLD 08

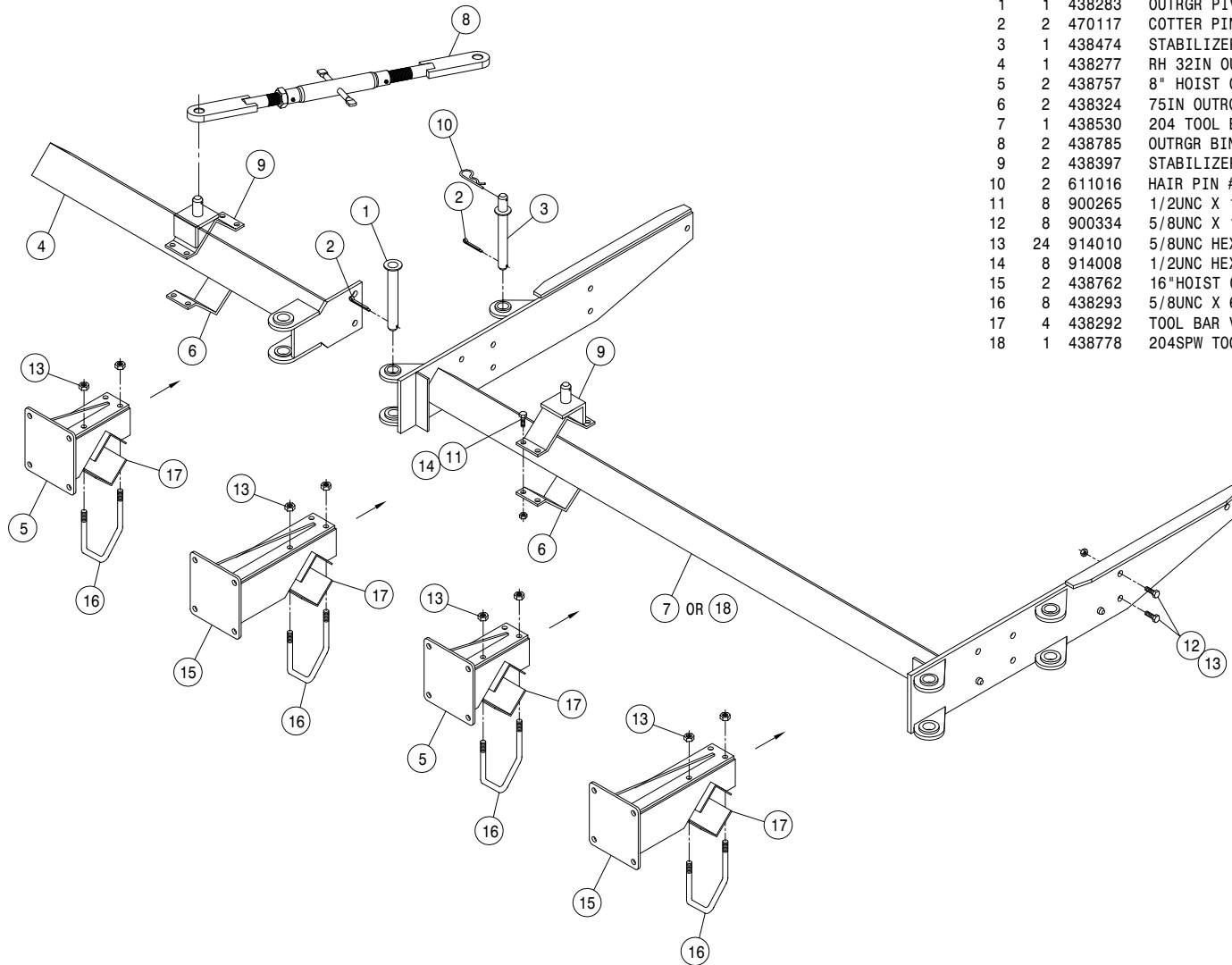

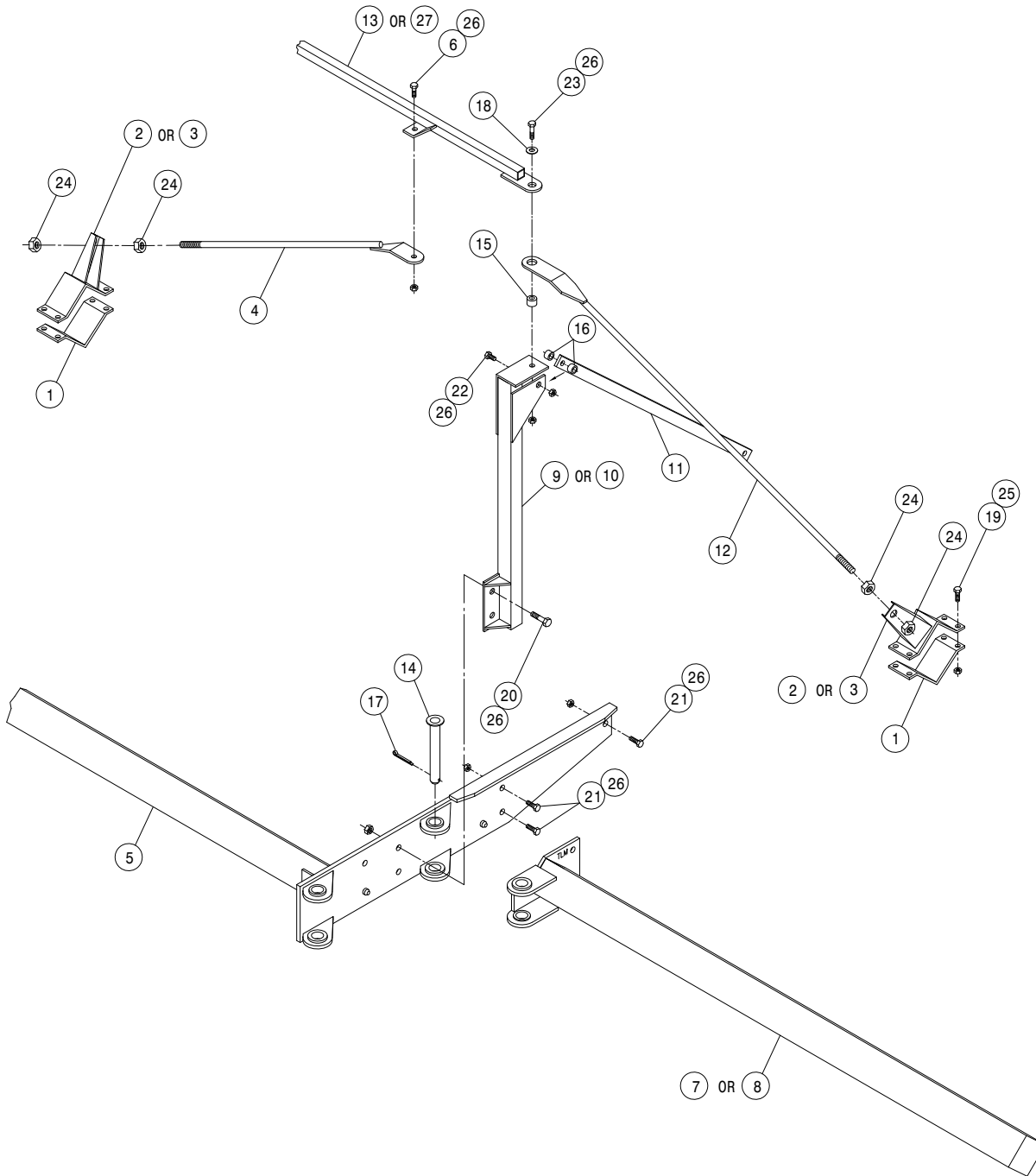

8-ROW, 4-LIFT OUTRIGGER ASSEMBLY

DET.	QTY	PART NO.	DESCRIPTION
1	4	438324	75IN OUTRGR BRACE CLAMP
2	2	438362	RH OUTRGR CLAMP WLD 200 89
3	2	438363	LH OUTRGR CLAMP WLD 200 89
4	2	438469	OUTRGR TIE BAR WLD 200 10-12R
5	1	438530	204 TOOL BAR WLD, 12R 5/6L 96
6	2	900333	5/8UNC X 1 1/2 HEX BOLT
7	1	438307	RH 75IN OUTRGR WLD8200-850086
8	1	438309	LH 75IN OUTRGR WLD8200-850086
9	1	438536	RH OUTRGR SUPP POST WLD10/12R
10	1	438537	LH OUTRGR SUPP POST WLD10/12R
11	2	438543	OUTRGR SUPP BRACE, 10/12R 96
12	2	438676	OUTRGR SUPP ROD WLD 72" 8R 01
13	1	438672	204 TIE TUBE WLD 2001
14	2	438283	OUTRGR PIVOT PIN WLD 8200 86
15	2	438232	BUSH, 1.00 OD X .656ID X .28
16	4	438542	BUSH, 1.00 OD X .656ID X .78
17	2	470117	COTTER PIN 3/16 1 3/4 SQ CUT
18	2	483037	5/8 REGULAR FLAT WASHER
19	16	900265	1/2UNC X 1 1/2 HEX BOLT
20	4	900336	5/8UNC X 2 1/2 HEX BOLT
21	6	900334	5/8UNC X 1 3/4 HEX BOLT
22	2	900339	5/8UNC X 3 1/4 HEX BOLT
23	2	900352	5/8UNC X 2 1/4 HEX BOLT
24	8	910012	3/4UNC HEX NUT
25	16	914008	1/2UNC HEX STOVER NUT
26	16	914010	5/8UNC HEX STOVER NUT
27	1	438780	204SPW CENTER TIE TUBE WLD 08

QUANTITY LISTED IS FOR ONE MACHINE.

8-ROW, 4-LIFT OUTRIGGER ASSEMBLY

DET. QTY PART NO. DESCRIPTION

DET.	QTY	PART NO.	DESCRIPTION
1	4	438324	75IN OUTGR BRACE CLAMP
2	2	438757	8" HOIST COL ADPTR WLD, 204 04
3	2	438785	OUTGR BINDER
4	8	914008	1/2UNC HEX STOVER NUT
5	2	438397	STABILIZER PIN MT WLD 90
6	16	914010	5/8UNC HEX STOVER NUT
7	4	438292	TOOL BAR V-PLT WLD 8200 86
8	8	438293	5/8UNC X 6 1/4 CTR U-BOLT TRI
9	2	438474	STABILIZER MT PIN WLD 10-12R
10	2	438476	OUTGR TRANSPORT BAR 10-12R
11	2	470117	COTTER PIN 3/16 1 3/4 SQ CUT
12	6	611016	HAIR PIN #6
13	8	900265	1/2UNC X 1 1/2 HEX BOLT
14	2	438762	16"HOIST COL ADPTR WLD, 204 04

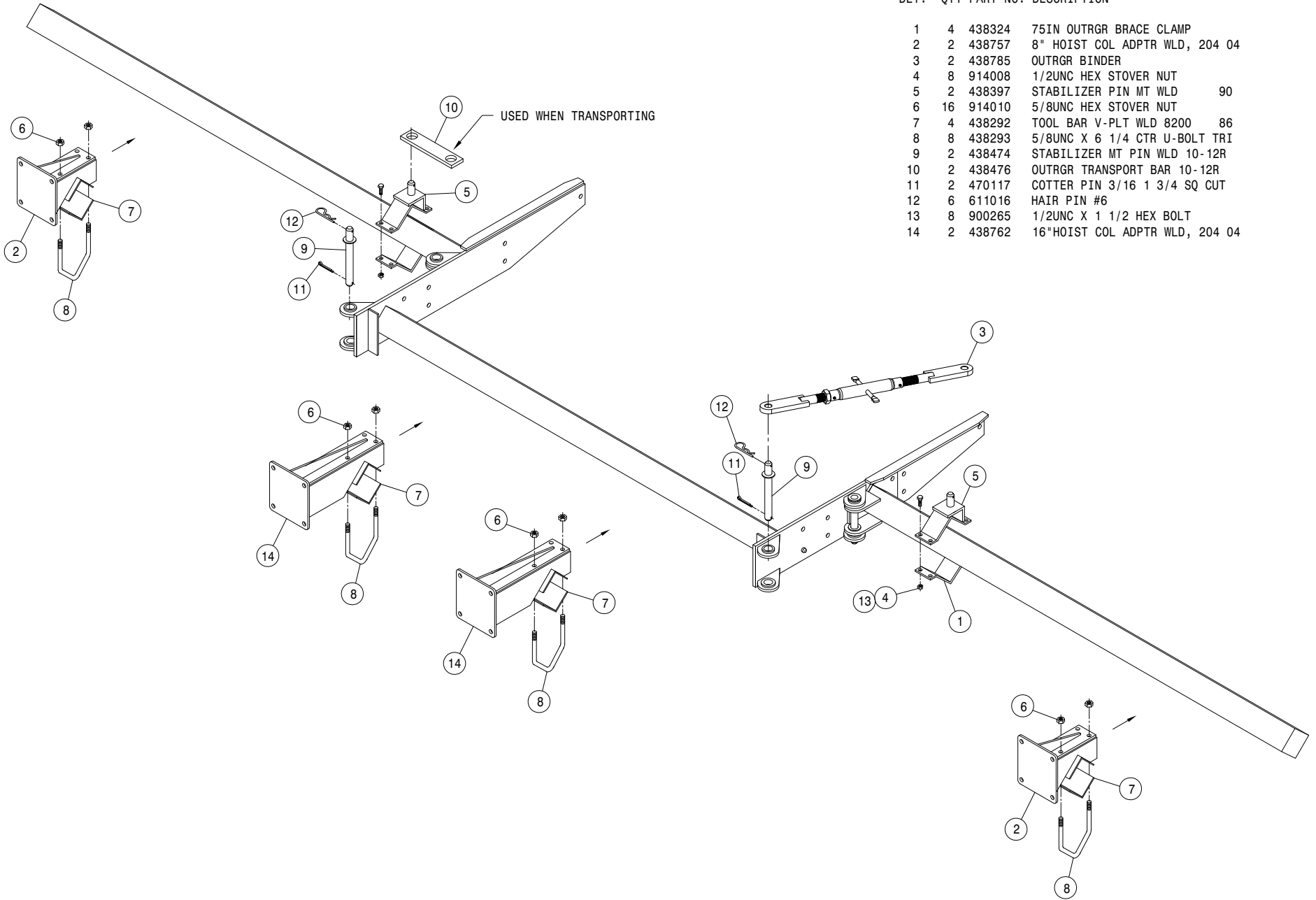

10-ROW, 4-LIFT OUTRIGGER ASSEMBLY

DET. QTY PART NO. DESCRIPTION

DET.	QTY	PART NO.	DESCRIPTION	
1	2	438324	75IN OUTGR BRACE CLAMP	
2	2	438362	RH OUTGR CLAMP WLD 200	89
3	2	438363	LH OUTGR CLAMP WLD 200	89
4	2	438469	OUTGR TIE BAR WLD 200 10-12R	
5	2	438471	OUTGR SUPP ROD WLD 10-12R	
6	1	438530	204 TOOL BAR WLD, 12R 5/6L	96
7	1	438458	RH 101IN OUTGR WLD 10-12R	92
8	1	438459	LH 101IN OUTGR WLD 10-12R	92
9	1	438536	RH OUTGR SUPP POST WLD10/12R	
10	1	438537	LH OUTGR SUPP POST WLD10/12R	
11	2	438543	OUTGR SUPP BRACE, 10/12R	96
12	2	900333	5/8UNC X 1 1/2 HEX BOLT	
13	1	438672	204 CENTER TIE TUBE WLD 2001	
14	2	438283	OUTGR PIVOT PIN WLD 8200	86
15	2	438232	BUSH, 1.00 OD- .656 ID- .28 LG	
16	4	438542	BUSH, 1.00 OD- .656 ID- .78 LG	
17	2	470117	COTTER PIN 3/16 1 3/4 SQ CUT	
18	2	483037	5/8 REGULAR FLAT WASHER	
19	16	900265	1/2UNC X 1 1/2 HEX BOLT	
20	4	900336	5/8UNC X 2 1/2 HEX BOLT	
21	6	900334	5/8UNC X 1 3/4 HEX BOLT	
22	2	900339	5/8UNC X 3 1/4 HEX BOLT	
23	2	900352	5/8UNC X 2 1/4 HEX BOLT	
24	8	910012	3/4UNC HEX NUT	
25	16	914008	1/2UNC HEX STOVER NUT	
26	16	914010	5/8UNC HEX STOVER NUT	
27	1	438778	204SPW TOOL BAR WLD	08
28	1	438780	204SPW CENTER TIE TUBE WLD	08

QUANTITY LISTED IS FOR ONE MACHINE.

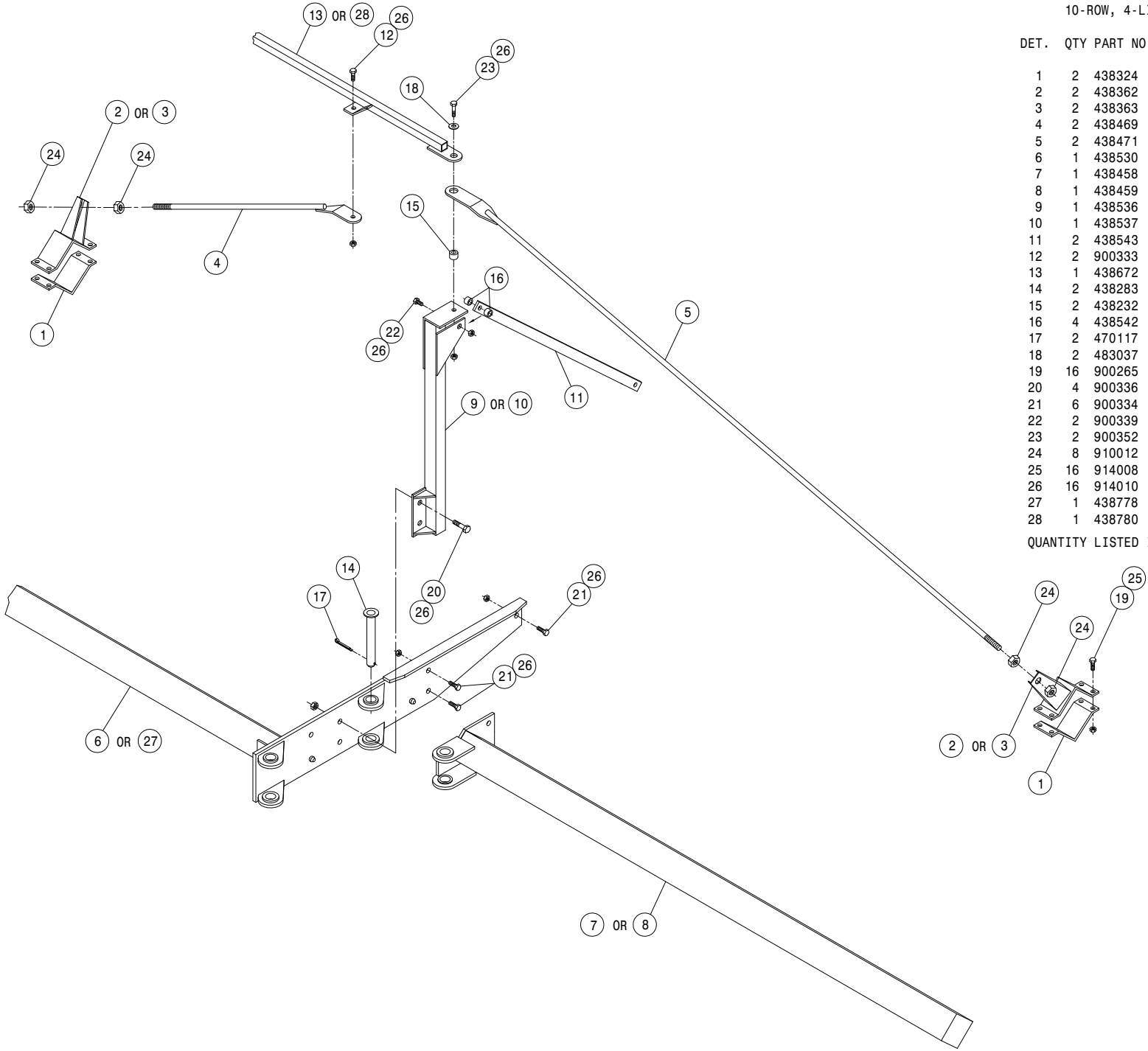

10-ROW, 4-LIFT OUTRIGGER ASSEMBLY

DET. QTY PART NO. DESCRIPTION

DET.	QTY	PART NO.	DESCRIPTION
1	2	438324	75IN OUTRGR BRACE CLAMP
2	2	438762	16"HOIST COL ADPTR WLD, 204 04
3	2	438785	OUTRGR BINDER
4	16	914008	1/2UNC HEX STOVER NUT
5	2	438397	STABILIZER PIN MT WLD 90
6	16	914010	5/8UNC HEX STOVER NUT
7	4	438292	TOOL BAR V-PLT WLD 8200 86
8	8	438293	5/8UNC X 6 1/4 CTR U-BOLT TRI
9	2	438474	STABILIZER MT PIN WLD 10-12R
10	2	438476	OUTRGR TRANSPORT BAR 10-12R
11	2	470117	COTTER PIN 3/16 1 3/4 SQ CUT
12	6	611016	HAIR PIN #6
13	16	900265	1/2UNC X 1 1/2 HEX BOLT
14	2	438757	8" HOIST COL ADPTR WLD, 204 04

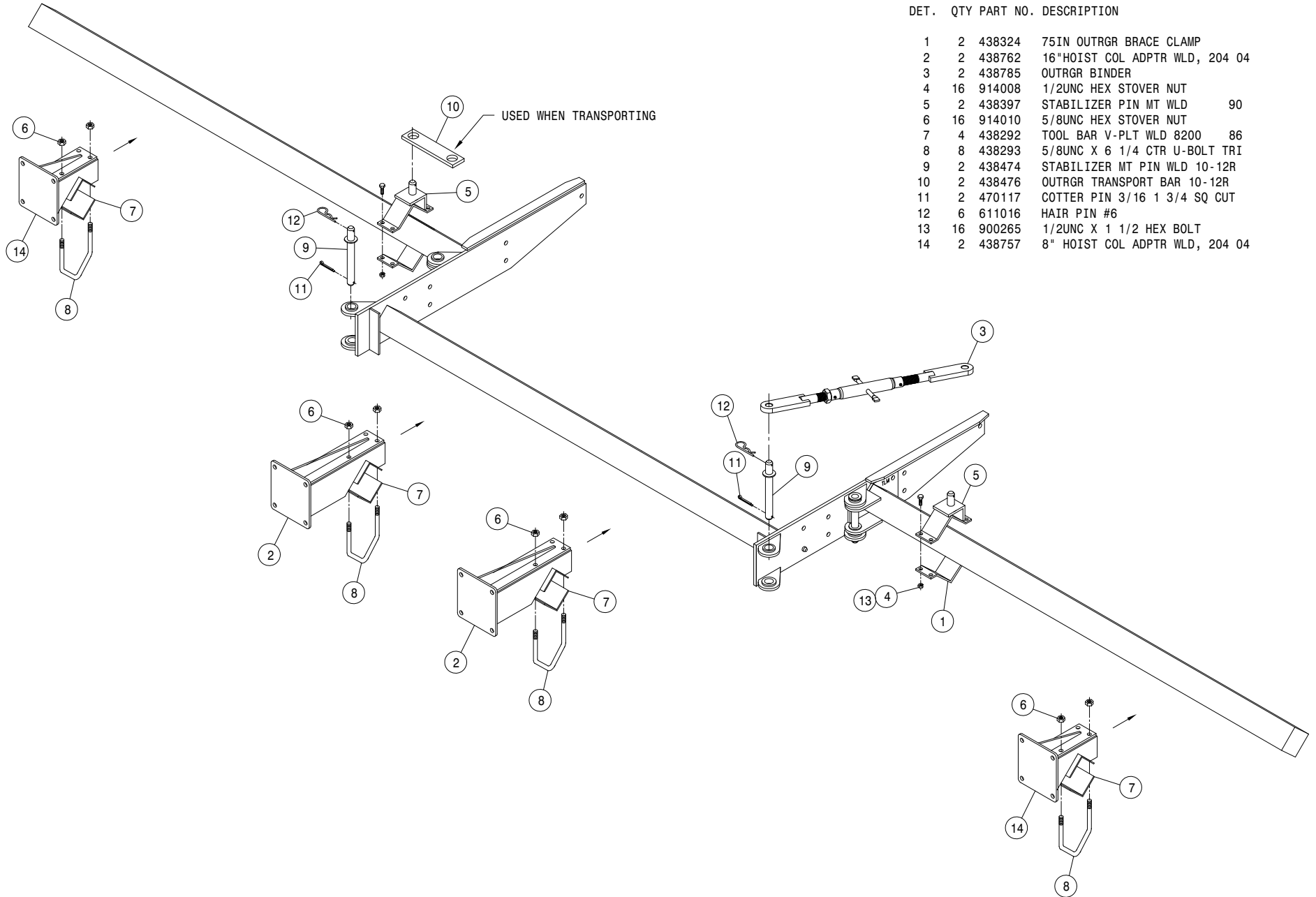

12-ROW, 4-LIFT OUTRIGGER ASSEMBLY

DET. QTY PART NO. DESCRIPTION

DET.	QTY	PART NO.	DESCRIPTION	
1	2	438324	75IN OUTGR BRACE CLAMP	
2	2	438362	RH OUTGR CLAMP WLD 200	89
3	2	438363	LH OUTGR CLAMP WLD 200	89
4	2	438469	OUTGR TIE BAR WLD 200 10-12R	
5	2	438471	OUTGR SUPP ROD WLD 10-12R	
6	1	438530	204 TOOL BAR WLD,12R 5/6L	96
7	1	438458	RH 101IN OUTGR WLD 10-12R	92
8	1	438459	LH 101IN OUTGR WLD 10-12R	92
9	1	438536	RH OUTGR SUPP POST WLD10/12R	
10	1	438537	LH OUTGR SUPP POST WLD10/12R	
11	2	438543	OUTGR SUPP BRACE,10/12R	96
12	2	900333	5/8UNC X 1 1/2 HEX BOLT	
13	1	438672	204 CENTER TIE TUBE WLD	2001
14	2	438283	OUTGR PIVOT PIN WLD 8200	86
15	2	438232	BUSH,1.00 OD- .656 ID- .28 LG	
16	4	438542	BUSH,1.00 OD- .656 ID- .78 LG	
17	2	470117	COTTER PIN 3/16 1 3/4 SQ CUT	
18	2	483037	5/8 REGULAR FLAT WASHER	
19	16	900265	1/2UNC X 1 1/2 HEX BOLT	
20	4	900336	5/8UNC X 2 1/2 HEX BOLT	
21	6	900334	5/8UNC X 1 3/4 HEX BOLT	
22	2	900339	5/8UNC X 3 1/4 HEX BOLT	
23	2	900352	5/8UNC X 2 1/4 HEX BOLT	
24	8	910012	3/4UNC HEX NUT	
25	16	914008	1/2UNC HEX STOVER NUT	
26	16	914010	5/8UNC HEX STOVER NUT	
27	1	438778	204SPW TOOL BAR WLD	08
28	1	438780	204SPW CENTER TIE TUBE WLD	08

QUANTITY LISTED IS FOR ONE MACHINE.

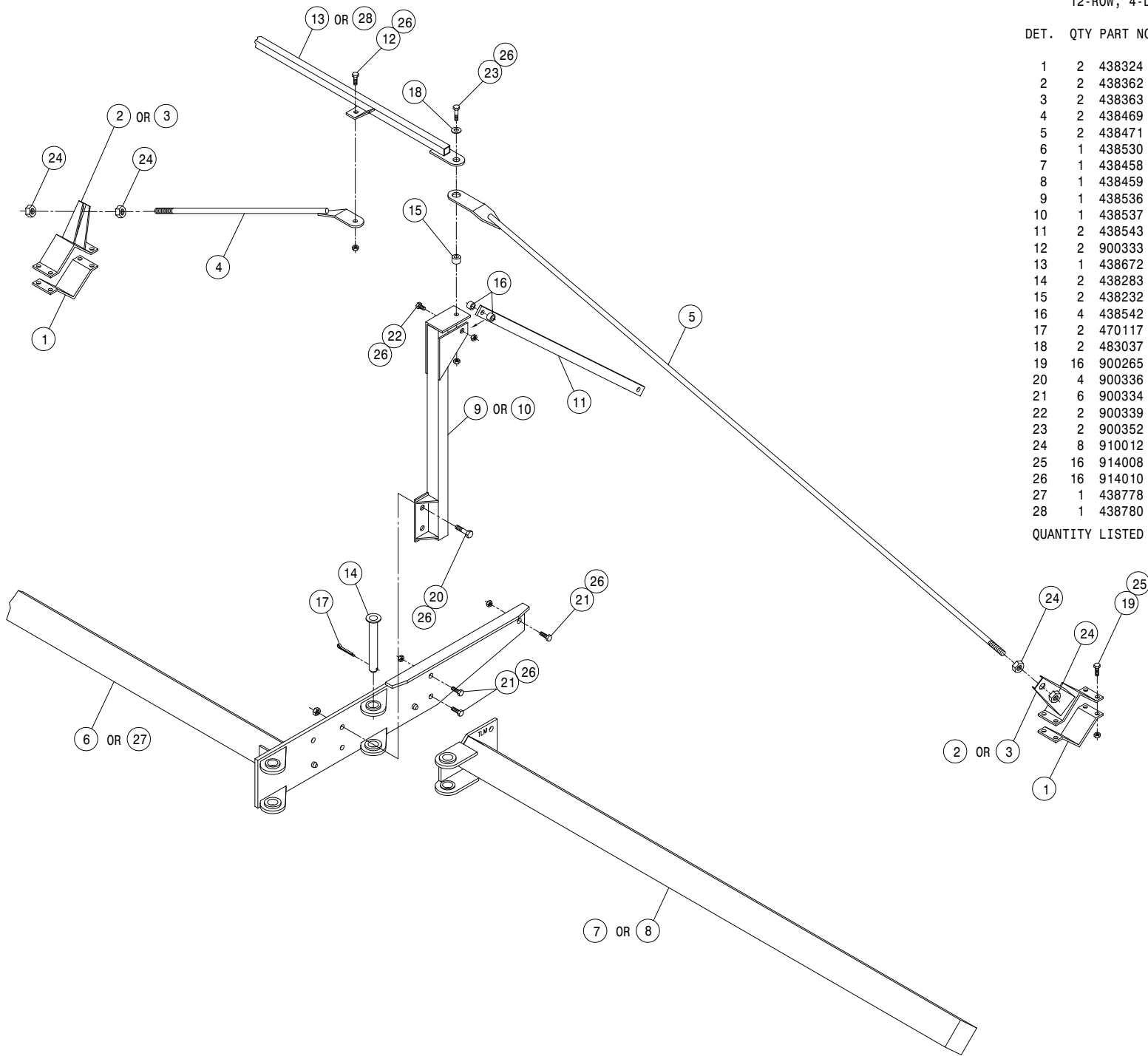

10-ROW, 4-LIFT OUTRIGGER ASSEMBLY

DET. QTY PART NO. DESCRIPTION

DET.	QTY	PART NO.	DESCRIPTION
1	2	438324	75IN OUTGR BRACE CLAMP
2	2	438762	16"HOIST COL ADPTR WLD, 204 04
3	2	438785	OUTGR BINDER
4	16	914008	1/2UNC HEX STOVER NUT
5	2	438397	STABILIZER PIN MT WLD 90
6	16	914010	5/8UNC HEX STOVER NUT
7	4	438292	TOOL BAR V-PLT WLD 8200 86
8	8	438293	5/8UNC X 6 1/4 CTR U-BOLT TRI
9	2	438474	STABILIZER MT PIN WLD 10-12R
10	2	438476	OUTGR TRANSPORT BAR 10-12R
11	2	470117	COTTER PIN 3/16 1 3/4 SQ CUT
12	6	611016	HAIR PIN #6
13	16	900265	1/2UNC X 1 1/2 HEX BOLT
14	2	438757	8" HOIST COL ADPTR WLD, 204 04

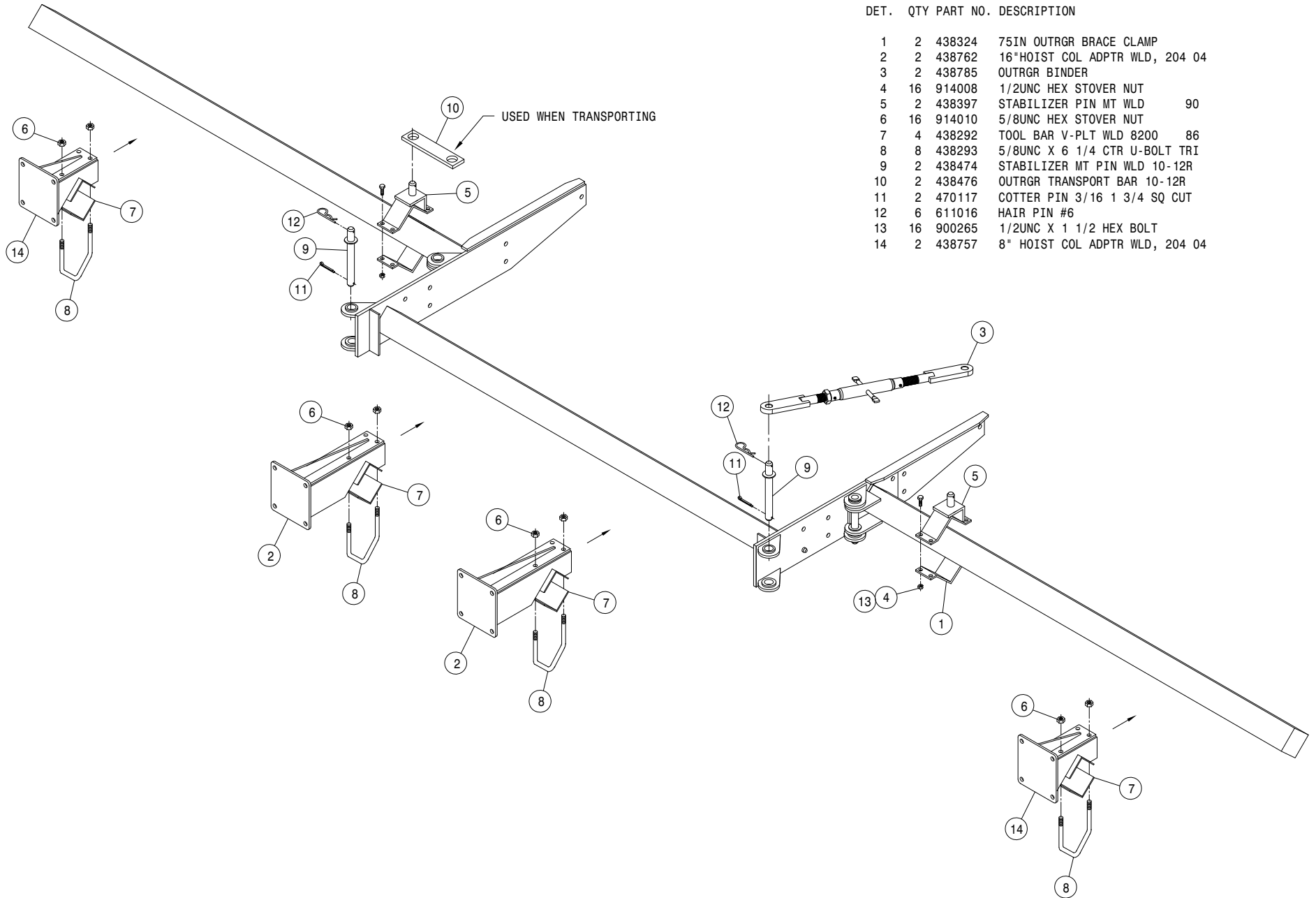

12-ROW, 6-LIFT OUTRIGGER ASSEMBLY

DET. QTY PART NO. DESCRIPTION

DET.	QTY	PART NO.	DESCRIPTION	
1	6	438324	75IN OUTGR BRACE CLAMP	
2	3	438362	RH OUTGR CLAMP WLD 200	89
3	3	438363	LH OUTGR CLAMP WLD 200	89
4	2	438469	OUTGR TIE BAR WLD 200 10-12R	
5	2	438471	OUTGR SUPP ROD WLD 10-12R	
6	1	438530	204 TOOL BAR WLD, 12R 5/6L	96
7	1	438533	RH 133" OUTGR WLD, 10/12R	96
8	1	438534	LH 133" OUTGR WLD, 10/12R	96
9	1	438536	RH OUTGR SUPP POST WLD10/12R	
10	1	438537	LH OUTGR SUPP POST WLD10/12R	
11	2	438543	OUTGR SUPP BRACE, 10/12R	96
12	2	438544	OUTGR SUPP ROD WLD 50"10/12R	
13	1	438672	204 CENTER TIE TUBE WLD 2001	
14	2	438283	OUTGR PIVOT PIN WLD 8200	86
15	2	438541	BUSH, 1.00 OD- .656 ID- .53 LG	
16	4	438542	BUSH, 1.00 OD- .656 ID- .78 LG	
17	2	470117	COTTER PIN 3/16 1 3/4 SQ CUT	
18	2	483037	5/8 REGULAR FLAT WASHER	
19	24	900265	1/2UNC X 1 1/2 HEX BOLT	
20	4	900336	5/8UNC X 2 1/2 HEX BOLT	
21	6	900334	5/8UNC X 1 3/4 HEX BOLT	
22	2	900339	5/8UNC X 3 1/4 HEX BOLT	
23	2	900352	5/8UNC X 2 1/4 HEX BOLT	
24	12	910012	3/4UNC HEX NUT	
25	24	914008	1/2UNC HEX STOVER NUT	
26	16	914010	5/8UNC HEX STOVER NUT	
27	2	900333	5/8UNC X 1 1/2 HEX BOLT	
28	1	438778	204SPW TOOL BAR WLD	08
29	1	490051	204SPW CENTER TIE TUBE WLD	08

QUANTITY LISTED IS FOR ONE MACHINE.

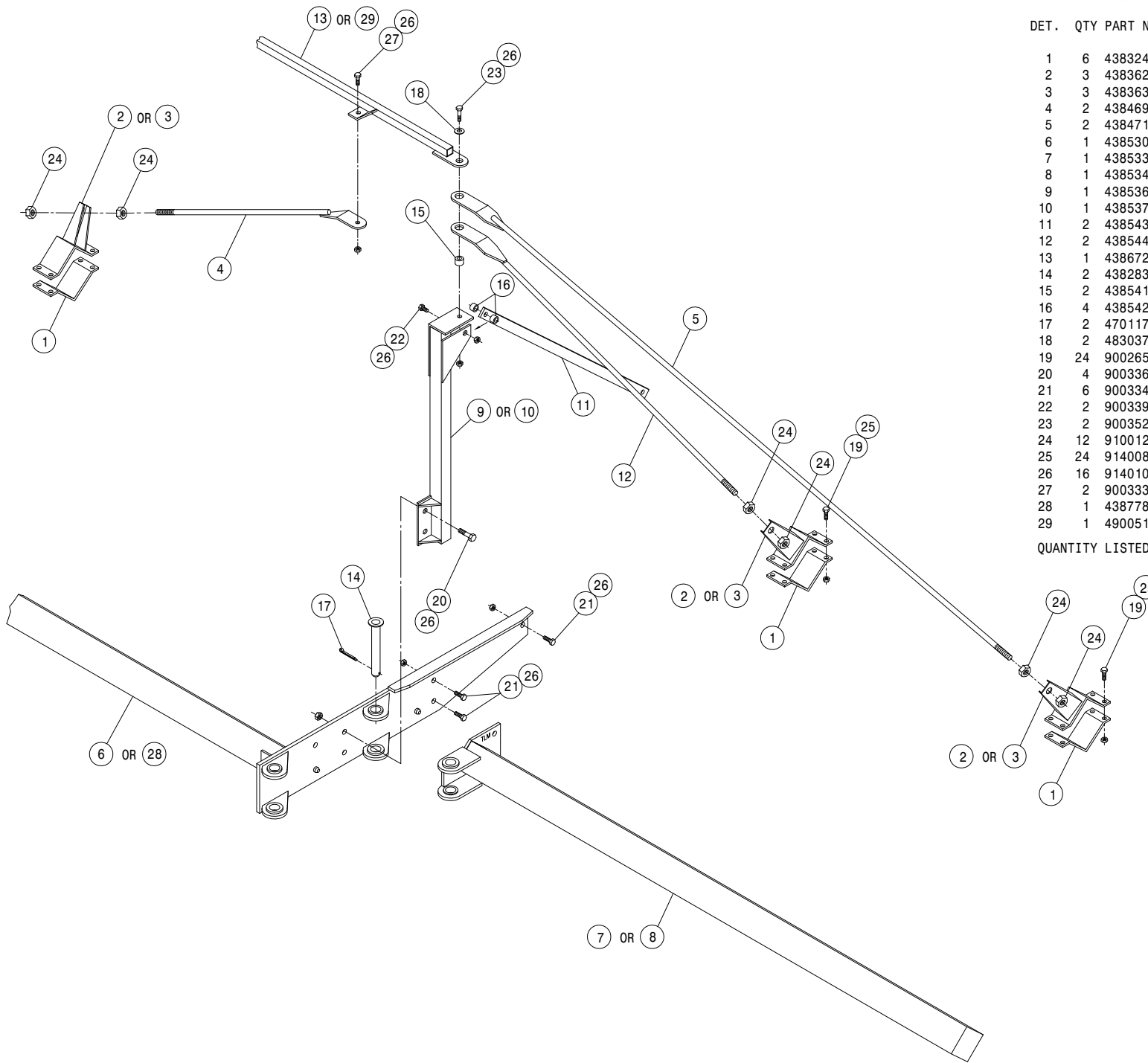

12-ROW, 6-LIFT OUTRIGGER ASSEMBLY

DET. QTY PART NO. DESCRIPTION

DET.	QTY	PART NO.	DESCRIPTION
1	2	438324	75IN OUTGR BRACE CLAMP
2	4	438757	8" HOIST COL ADPTR WLD, 204 04
3	2	438785	OUTGR BINDER
4	12	914008	1/2UNC HEX STOVER NUT
5	4	438397	STABILIZER PIN MT WLD 90
6	24	914010	5/8UNC HEX STOVER NUT
7	6	438292	TOOL BAR V-PLT WLD 8200 86
8	12	438293	5/8UNC X 6 1/4 CTR U-BOLT TRI
9	2	438474	STABILIZER MT PIN WLD 10-12R
10	2	438476	OUTGR TRANSPORT BAR 10-12R
11	2	470117	COTTER PIN 3/16 1 3/4 SQ CUT
12	6	611016	HAIR PIN #6
13	12	900265	1/2UNC X 1 1/2 HEX BOLT
14	2	438762	16"HOIST COL ADPTR WLD, 204 04

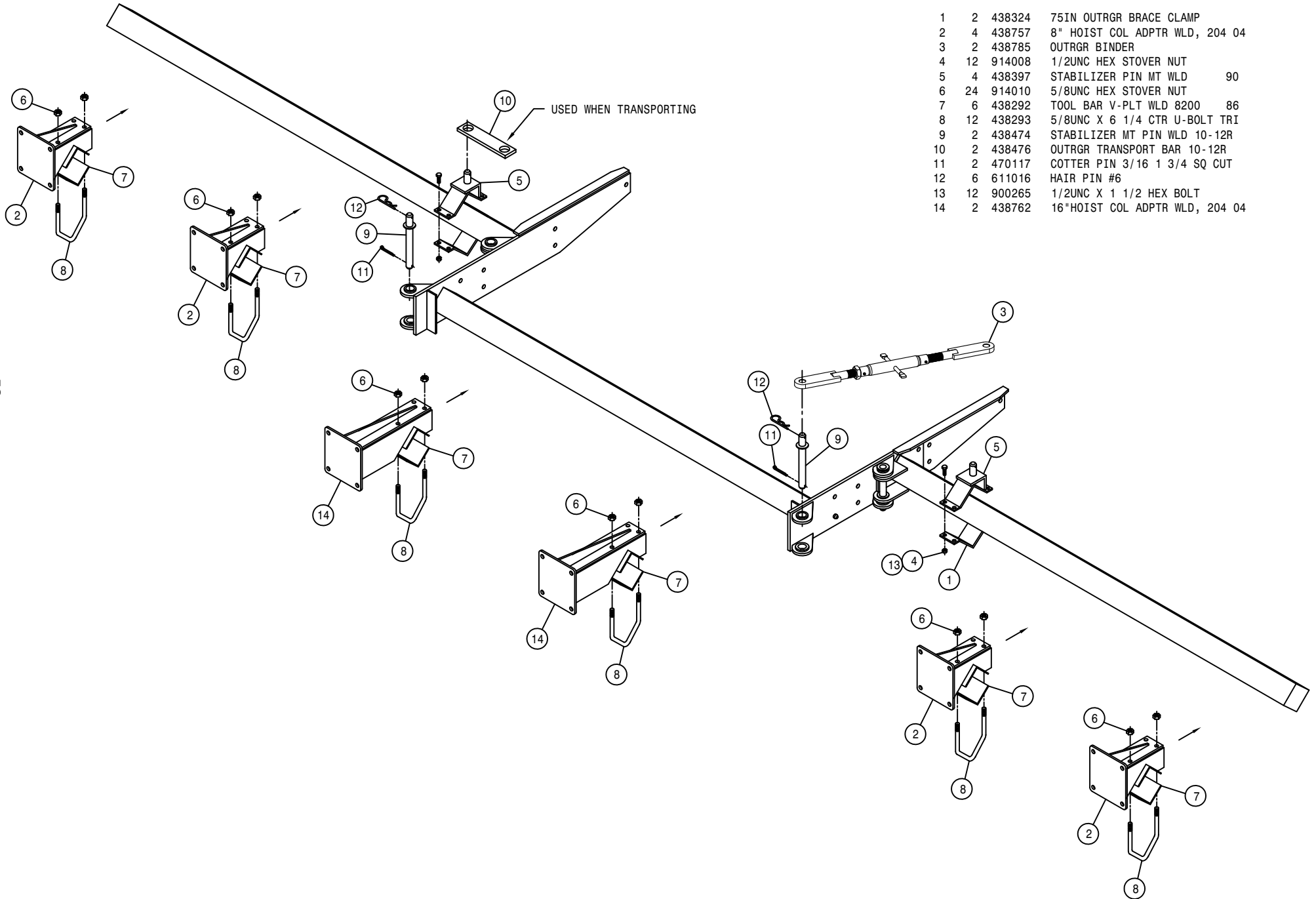

12-ROW, 6-LIFT, 52CM SPACING OUTRIGGER ASSEM

DET. QTY PART NO. DESCRIPTION

1	4	438324	75IN OUTGR BRACE CLAMP	
2	2	438362	RH OUTGR CLAMP WLD 200	89
3	2	438363	LH OUTGR CLAMP WLD 200	89
4	2	439176	OUTGR TIE BAR WLD 204	52CM
5	2	439175	OUTGR SUPP ROD WLD 204	52CM
6	1	438530	204 TOOL BAR WLD,12R 5/6L	96
7	1	438497	RH 82" OUTGR WLD, 204	94
8	1	438498	LH 82" OUTGR WLD, 204	94
9	1	439173	RH OUTGR SUPP POST WLD	52CM
10	1	439174	LH OUTGR SUPP POST WLD	52CM
11	1	438355	RH OUTGR SUPP BRACE 200	89
12	1	438356	LH OUTGR SUPP BRACE 200	89
13	22	914008	1/2UNC HEX STOVER NUT	
14	2	438283	OUTGR PIVOT PIN WLD 8200	86
15	2	438541	BUSH,1.00 OD- .656 ID- .53 LG	
16	12	914010	5/8UNC HEX STOVER NUT	
17	2	470117	COTTER PIN 3/16 1 3/4 SQ CUT	
18	2	483037	5/8 REGULAR FLAT WASHER	
19	16	900265	1/2UNC X 1 1/2 HEX BOLT	
20	4	900271	1/2UNC X 3 1/4 HEX BOLT	
21	8	900334	5/8UNC X 1 3/4 HEX BOLT	
22	2	900264	1/2UNC X 1 1/4 HEX BOLT	
23	2	900352	5/8UNC X 2 1/4 HEX BOLT	
24	8	910012	3/4UNC HEX NUT	
25	1	438672	204 CENTER TIE TUBE WLD	2001
26	2	900333	5/8UNC X 1 1/2 HEX BOLT	
27	1	438778	204SPW TOOL BAR WLD	08
28	1	438780	204SPW CENTER TIE TUBE WLD	08

QUANTITY LISTED IS FOR ONE MACHINE.

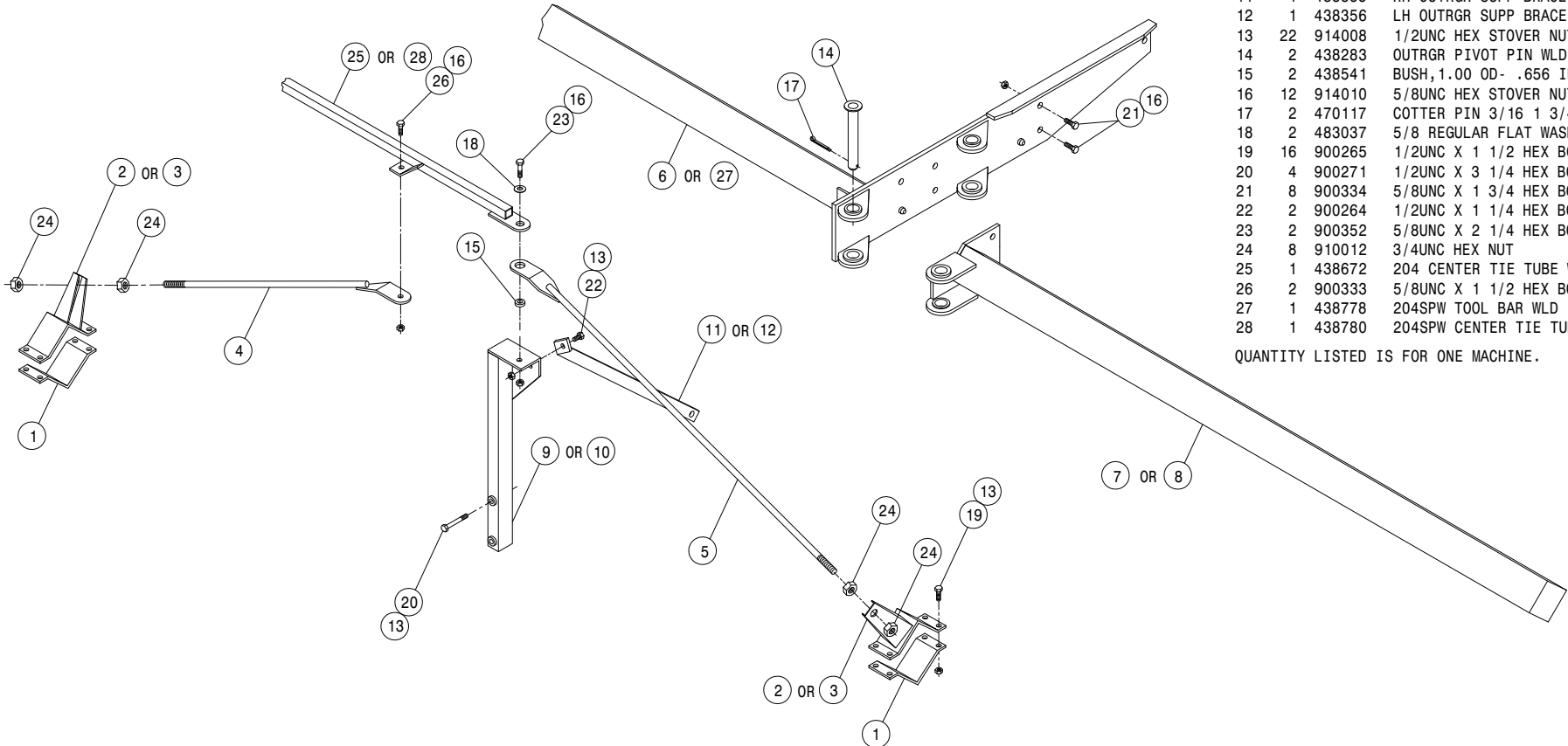

12-ROW, 6-LIFT, 52CM SPACING OUTRIGGER ASSEM

DET. QTY PART NO. DESCRIPTION

DET.	QTY	PART NO.	DESCRIPTION
1	6	438324	75IN OUTGR BRACE CLAMP
2	4	438757	8" HOIST COL ADPTR WLD, 204 04
3	2	438785	OUTGR BINDER
4	24	914008	1/2UNC HEX STOVER NUT
5	6	438397	STABILIZER PIN MT WLD 90
6	24	914010	5/8UNC HEX STOVER NUT
7	6	438292	TOOL BAR V-PLT WLD 8200 86
8	12	438293	5/8UNC X 6 1/4 CTR U-BOLT TRI
9	2	438474	STABILIZER MT PIN WLD 10-12R
10	2	438656	OUTGR TRANSPORT BAR,2100COMBO
11	2	470117	COTTER PIN 3/16 1 3/4 SQ CUT
12	6	611016	HAIR PIN #6
13	24	900265	1/2UNC X 1 1/2 HEX BOLT
14	2	438762	16"HOIST COL ADPTR WLD, 204 04

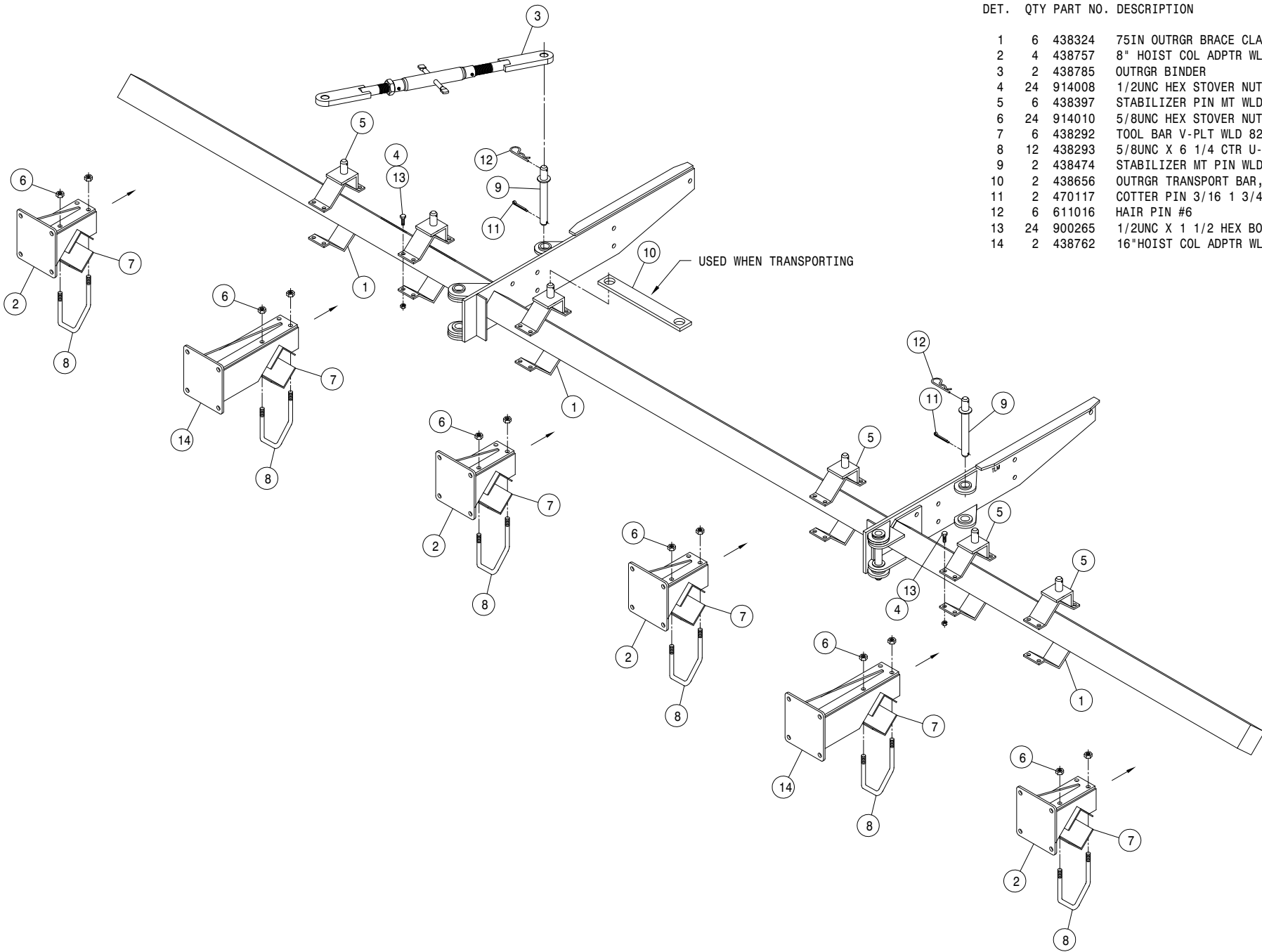

18-ROW, 6-LIFT, 20" SPACING OUTRIGGER ASSEMBLY

DET. QTY PART NO. DESCRIPTION

1	6	438324	75IN OUTRGR BRACE CLAMP	
2	3	438362	RH OUTRGR CLAMP WLD 200	89
3	3	438363	LH OUTRGR CLAMP WLD 200	89
4	2	438770	OUTRGR TIE BAR WLD,66" 204 18R	
5	2	438471	OUTRGR SUPP ROD WLD 10-12R	
6	1	438530	204 TOOL BAR WLD,12R 5/6L	96
7	1	438533	RH 133" OUTRGR WLD, 10/12R	96
8	1	438534	LH 133" OUTRGR WLD, 10/12R	96
9	1	438536	RH OUTRGR SUPP POST WLD10/12R	
10	1	438537	LH OUTRGR SUPP POST WLD10/12R	
11	2	438543	OUTRGR SUPP BRACE,10/12R	96
12	2	438676	OUTRGR SUPP ROD WLD 72" 8R 01	
13	1	438672	204 CENTER TIE TUBE WLD	2001
14	2	438283	OUTRGR PIVOT PIN WLD 8200	86
15	4	920008	1" SAE FLAT WASHER	
16	6	438542	BUSH,1.00 OD- .656 ID- .78 LG	
17	2	470117	COTTER PIN 3/16 1 3/4 SQ CUT	
18	2	483037	5/8 REGULAR FLAT WASHER	
19	24	900265	1/2UNC X 1 1/2 HEX BOLT	
20	6	900336	5/8UNC X 2 1/2 HEX BOLT	
21	6	900334	5/8UNC X 1 3/4 HEX BOLT	
22	2	900339	5/8UNC X 3 1/4 HEX BOLT	
23	16	914010	5/8UNC HEX STOVER NUT	
24	12	910012	3/4UNC HEX NUT	
25	24	914008	1/2UNC HEX STOVER NUT	
26	2	900333	5/8UNC X 1 1/2 HEX BOLT	
27	1	438778	204SPW TOOL BAR WLD	08
28	1	438780	204SPW CENTER TIE TUBE WLD	08

QUANTITY LISTED IS FOR ONE MACHINE.

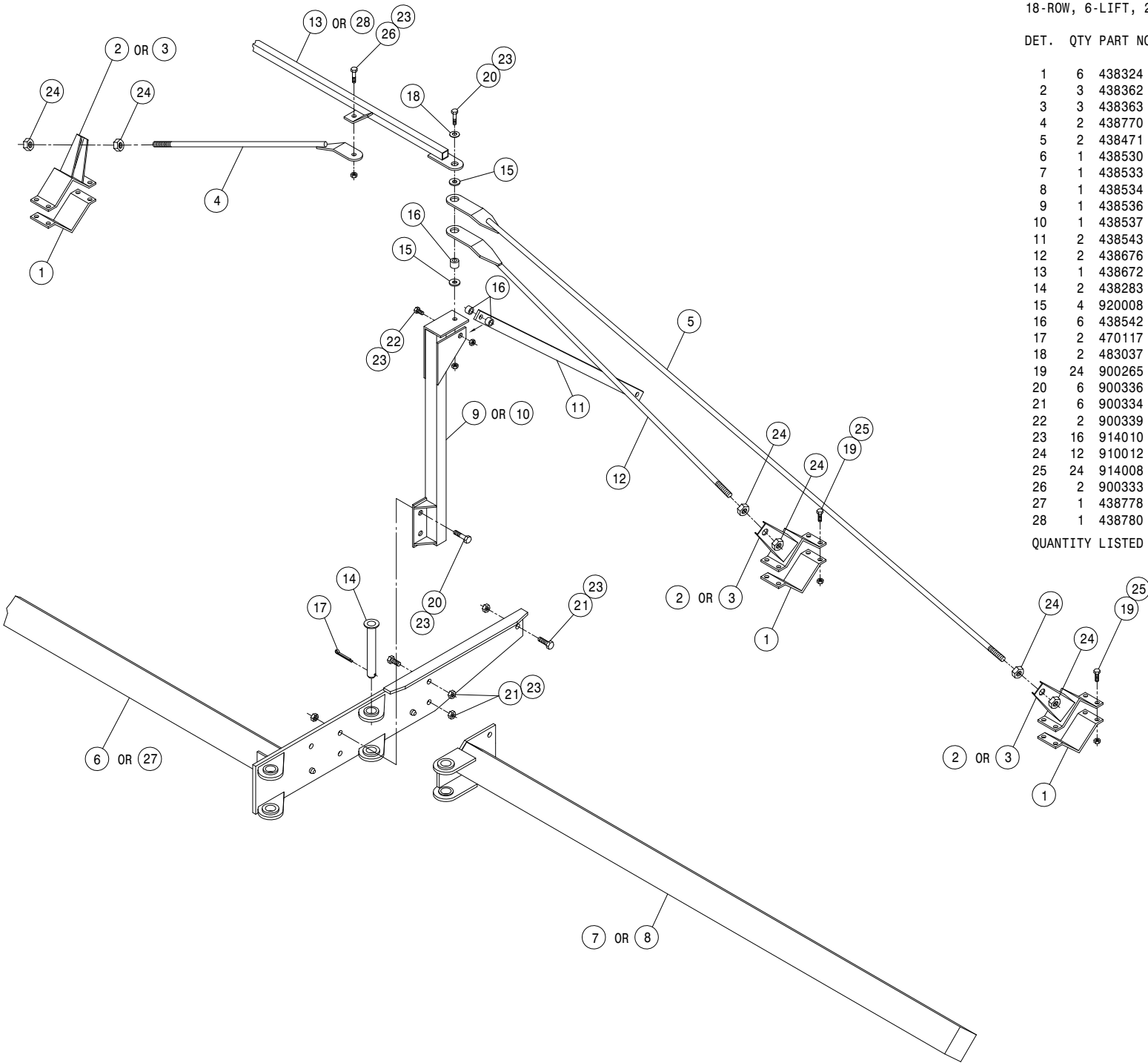

18-ROW, 6-LIFT, 20" SPACING OUTRIGGER ASSEMB

DET. QTY PART NO. DESCRIPTION

DET.	QTY	PART NO.	DESCRIPTION
1	4	438324	75IN OUTGR BRACE CLAMP
2	2	438762	16"HOIST COL ADPTR WLD, 204 04
3	2	438785	OUTGR BINDER
4	16	914008	1/2UNC HEX STOVER NUT
5	4	438397	STABILIZER PIN MT WLD 90
6	24	914010	5/8UNC HEX STOVER NUT
7	6	438292	TOOL BAR V-PLT WLD 8200 86
8	12	438293	5/8UNC X 6 1/4 CTR U-BOLT TRI
9	2	438474	STABILIZER MT PIN WLD 10-12R
10	2	438476	OUTGR TRANSPORT BAR 10-12R
11	2	470117	COTTER PIN 3/16 1 3/4 SQ CUT
12	6	611016	HAIR PIN #6
13	16	900265	1/2UNC X 1 1/2 HEX BOLT
14	4	438757	8" HOIST COL ADPTR WLD, 204 04

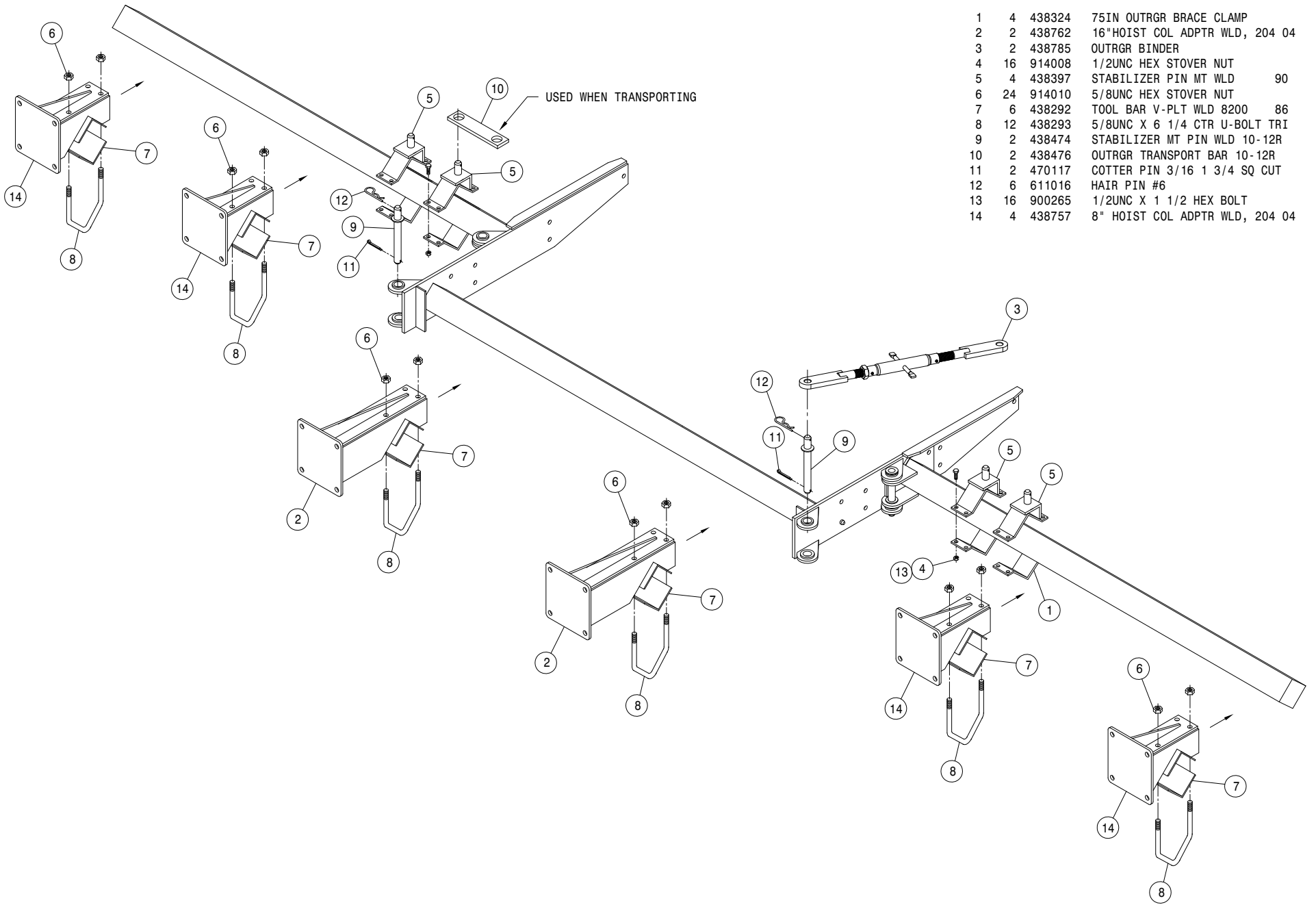

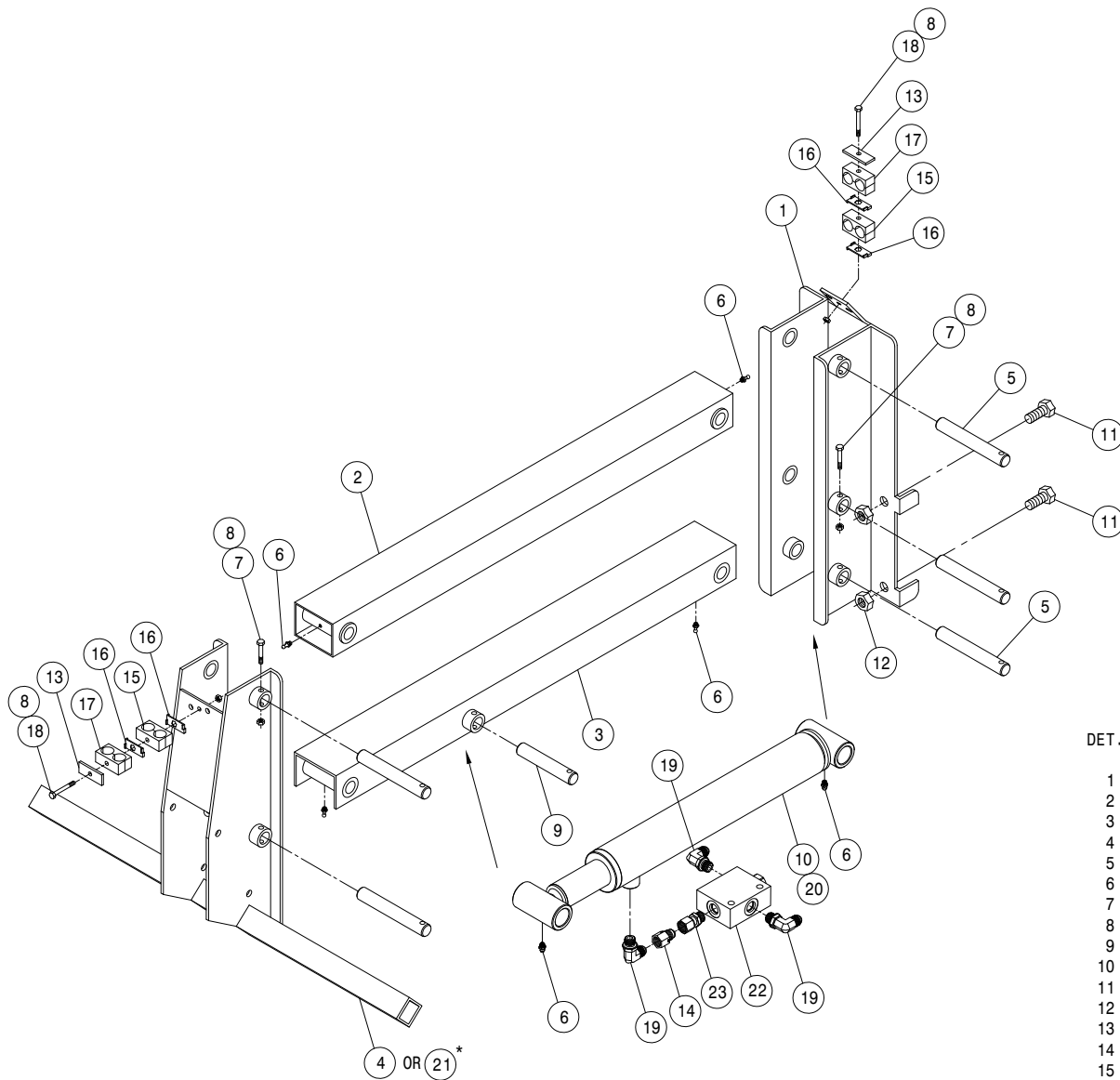

2-HEAD LIFT ASSEMBLY

DET.	QTY	PART NO.	DESCRIPTION	
1	1	439136	TOOLBAR MT BRKT WLD, STSC	03
2	1	439143	UPPER LIFTARM WLD, STS COMBO	03
3	1	439146	LWR LIFTARM WLD, STS COMBO	03
4	1	439151	50" HEAD TOOLBAR WLD, STSC	03
5	5	439158	LIFT ARM PIVOT PIN, STSC	03
6	6	471005	GREASE ZERK, 1/4 28 X 1/2	
7	6	900069	5/16UNC X 2" HEX BOLT	
8	8	914002	5/16UNC HEX STOVER NUT	
9	1	439156	LWR CYL MT PIN, STS COMBO	03
10	1	621564	HYD CYL, 2.00 X 11.00 X 1.50 1W	
11	4	900401	3/4UNC X 1 1/2 HEX BOLT	
12	4	914012	3/4UNC HEX STOVER NUT	
13	2	470276	CLAMP COVER PLATE, SNGL, 2.55LG	
14	1	618733	9/16JIC .042 ORIFICE ADPTR	
15	2	470274	TUBE CLAMP BODY, .750-.750	
16	4	470281	STACK BOLT SAFETY LOCK PLATE	
17	2	470270	HOSE CLAMP BODY, .530-.680	
18	2	900075	5/16UNC X 3 3/4 HEX BOLT	
19	3	618119	9/16MJIC-90-9/16MOR LBO	
20	1	621507	REPAIR KIT, HYD CYL 621506	
21	1	439197	33" HEAD TOOLBAR WLD, 20"R	06
22	1	607565	CHECK VLV, PILOT TO OPEN, SUN	
23	1	618668	9/16FJIC SWIV-9/16MOR ADPTR	

NOTE: DETAILS MARKED WITH A (*) ARE USED WITH THE 20" ROW OPTION.

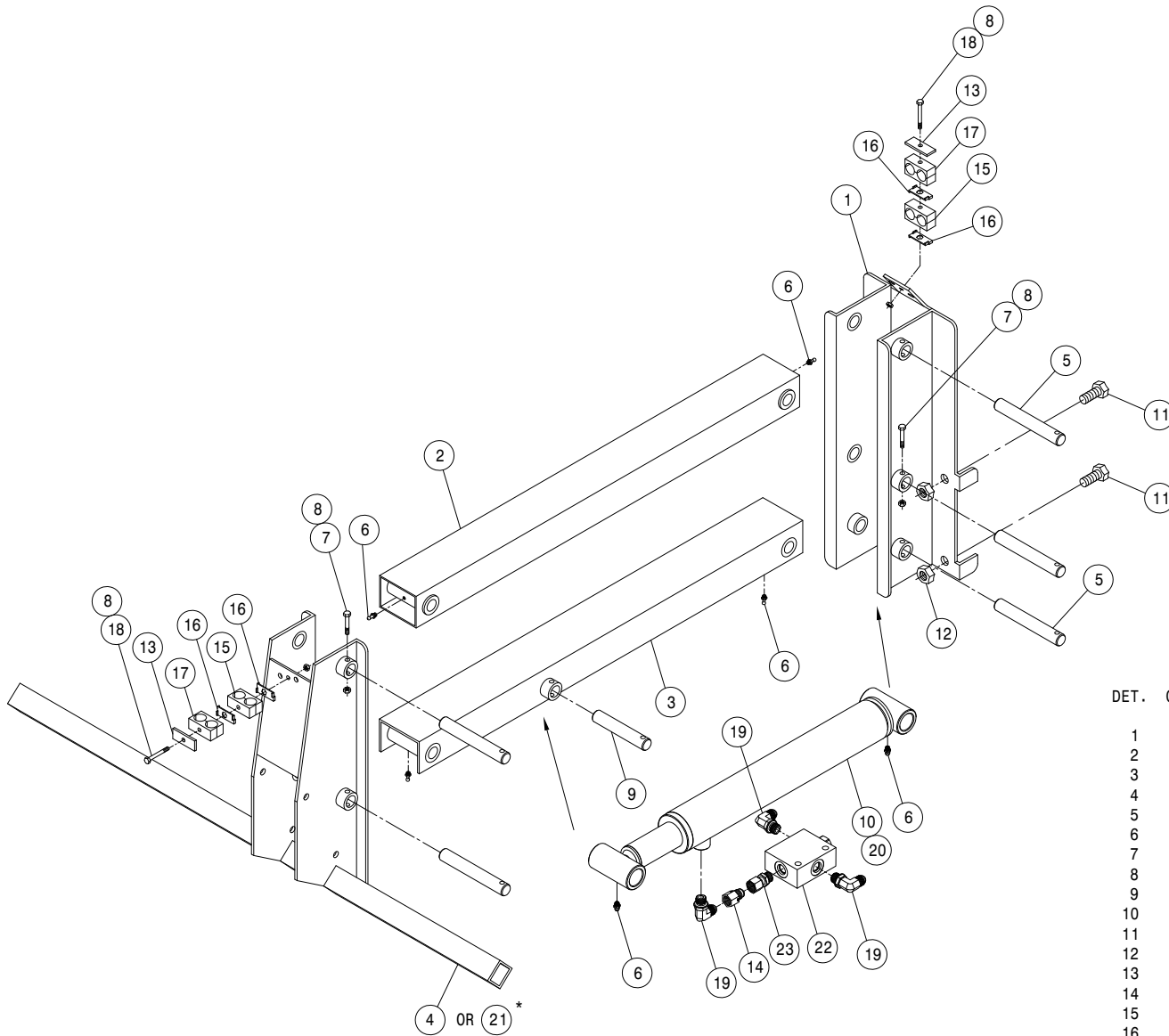

RIGHT 3-HEAD LIFT ASSEMBLY

DET.	QTY	PART NO.	DESCRIPTION
1	1	439136	TOOLBAR MT BRKT WLD, STSC 03
2	1	439143	UPPER LIFTARM WLD,STS COMBO 03
3	1	439146	LWR LIFTARM WLD, STS COMBO 03
4	1	439163	80"RH HEAD TOOLBAR WLD,STSC 03
5	5	439158	LIFT ARM PIVOT PIN, STSC 03
6	6	471005	GREASE ZERK, 1/4 28 X 1/2
7	6	900069	5/16UNC X 2" HEX BOLT
8	8	914002	5/16UNC HEX STOVER NUT
9	1	439156	LWR CYL MT PIN, STS COMBO 03
10	1	621564	HYD CYL,2.00 X 11.00 X 1.50 1W
11	4	900401	3/4UNC X 1 1/2 HEX BOLT
12	4	914012	3/4UNC HEX STOVER NUT
13	2	470276	CLAMP COVER PLATE,SNGL, 2.55LG
14	1	618733	9/16JIC .042 ORIFICE ADPTR
15	2	470274	TUBE CLAMP BODY,.750-.750
16	4	470281	STACK BOLT SAFETY LOCK PLATE
17	2	470270	HOSE CLAMP BODY,.530-.680
18	2	900075	5/16UNC X 3 3/4 HEX BOLT
19	3	618119	9/16MJIC-90-9/16MOR LBO
20	1	621507	REPAIR KIT, HYD CYL 621506
21	1	439182	57"RH HEAD TOOLBAR WLD,20"R 05
22	1	607565	CHECK VLV,PILOT TO OPEN, SUN
23	1	618668	9/16FJIC SWIV-9/16MOR ADPTR

NOTE: DETAILS MARKED WITH A (*) ARE USED
THE 20" ROW OPTION.

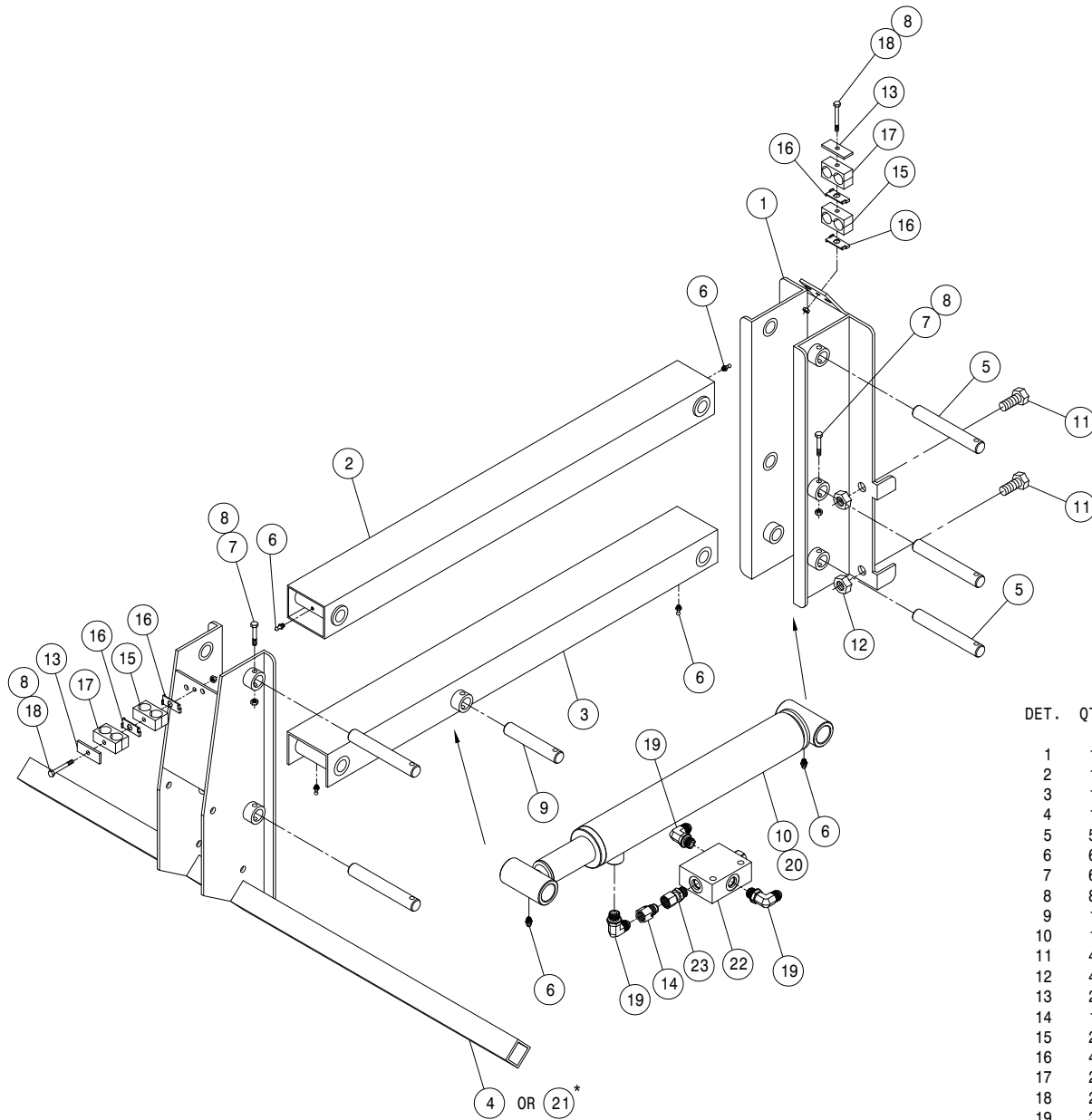

LEFT 3-HEAD LIFT ASSEMBLY

DET. QTY PART NO. DESCRIPTION

DET.	QTY	PART NO.	DESCRIPTION	
1	1	439136	TOOLBAR MT BRKT WLD, STSC	03
2	1	439143	UPPER LIFTARM WLD,STS COMBO	03
3	1	439146	LWR LIFTARM WLD, STS COMBO	03
4	1	439164	80"LH HEAD TOOLBAR WLD,STSC	03
5	5	439158	LIFT ARM PIVOT PIN, STSC	03
6	6	471005	GREASE ZERK, 1/4 28 X 1/2	
7	6	900069	5/16UNC X 2" HEX BOLT	
8	8	914002	5/16UNC HEX STOVER NUT	
9	1	439156	LWR CYL MT PIN, STS COMBO	03
10	1	621564	HYD CYL,2.00 X 11.00 X 1.50 1W	
11	4	900401	3/4UNC X 1 1/2 HEX BOLT	
12	4	914012	3/4UNC HEX STOVER NUT	
13	2	470276	CLAMP COVER PLATE,SNGL, 2.55LG	
14	1	618733	9/16JIC .042 ORIFICE ADPTR	
15	2	470274	TUBE CLAMP BODY,.750-.750	
16	4	470281	STACK BOLT SAFETY LOCK PLATE	
17	2	470270	HOSE CLAMP BODY,.530-.680	
18	2	900075	5/16UNC X 3 3/4 HEX BOLT	
19	3	618119	9/16MJIC-90-9/16MOR LBO	
20	1	621507	REPAIR KIT, HYD CYL 621506	
21	1	439183	57"LH HEAD TOOLBAR WLD,20"R	05
22	1	607565	CHECK VLV,PILOT TO OPEN, SUN	
23	1	618668	9/16FJIC SWIV-9/16MOR ADPTR	

NOTE: DETAILS MARKED WITH (*) ARE USED WITH THE 20" ROW OPTION.

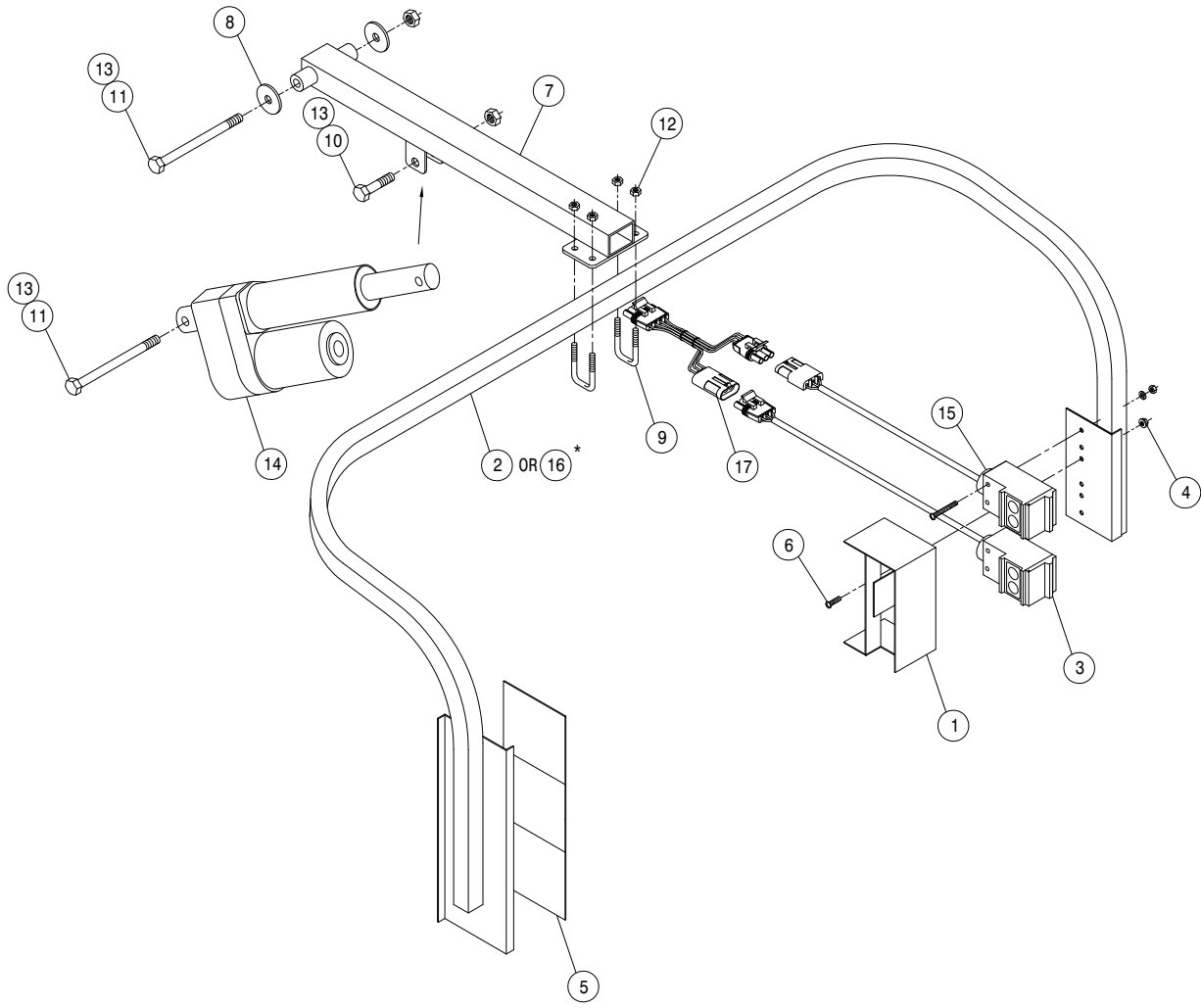

LS SENSOR ASSEMBLY

DET.	QTY	PART NO.	DESCRIPTION
	1	002841	LS 42GRU SENSOR SHIELD WLD
	1	003033	LS SENSOR MT WLD, STS COMBO 03
	1	293258	LWR LS 9200 SENSOR ASSY, FEM
	2	473004	10-32 FLANGE NYLOC NUT
	3	650297	REFLECTIVE TAPE, 4 X 4, RTC4-4P
	2	903883	10-32 X 1/2 SLT RDHD MACH SCR
	1	003028	LS SENSOR MT SUPP WLD, STSC 03
	2	002815	SENSOR ARM WASH, NYL
	2	473980	.31UNC-1.06ID-1.75SQ U-BOLT SS
	1	900267	1/2UNC X 2" HEX BOLT
	2	900278	1/2UNC X 6" HEX BOLT
	4	914002	5/16UNC HEX STOVER NUT
	3	914008	1/2UNC HEX STOVER NUT
	1	291634	LINEAR ACTUATOR, KODIAK K2
	1	293259	UPR LS 9200 SENSOR ASSY, MALE
	1	003050	LS SENSOR MT WLD, 20"R 204 04
	1	293188	SENSOR CONNECTOR WIRE ASSY

NOTE: DETAILS MARKER WITH A (*) ARE USED WITH THE 20" ROW OPTION.

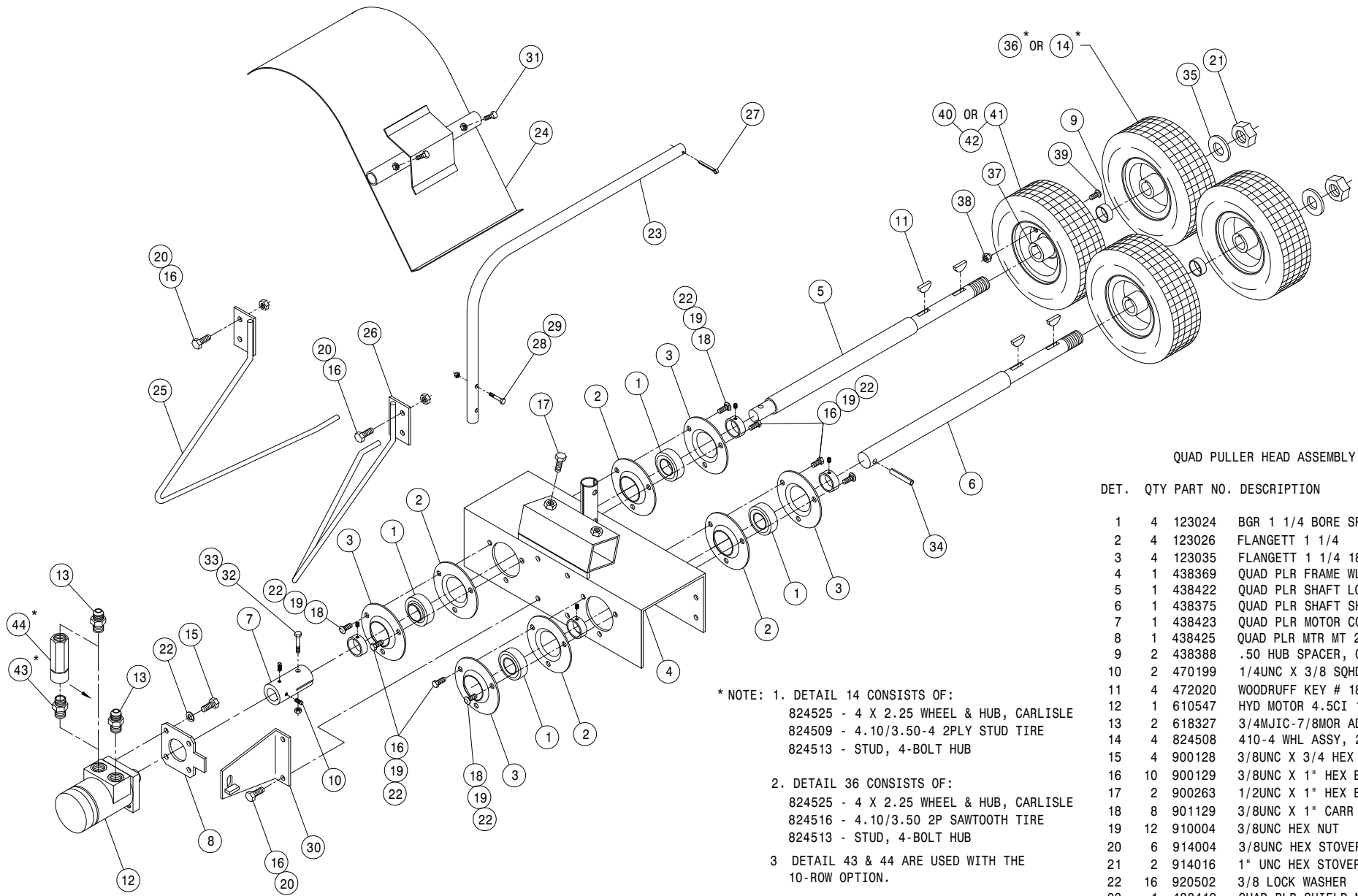

QUAD PULLER HEAD ASSEMBLY

DET.	QTY	PART NO.	DESCRIPTION
1	4	123024	BGR 1 1/4 BORE SPHERICL RELUB
2	4	123026	FLANGETT 1 1/4
3	4	123035	FLANGETT 1 1/4 180 DEG ZERK
4	1	438369	QUAD PLR FRAME WLD 200 90
5	1	438422	QUAD PLR SHAFT LONG 200 91
6	1	438375	QUAD PLR SHAFT SHORT 200 90
7	1	438423	QUAD PLR MOTOR COUPLER 200 91
8	1	438425	QUAD PLR MTR MT 200 91
9	2	438388	.50 HUB SPACER, QUAD PLR
10	2	470199	1/4UNC X 3/8 SQHD CUP SET SCR
11	4	472020	WOODRUFF KEY # 18 1/4 X 1 1/8
12	1	610547	HYD MOTOR 4.5CI 1IN SHFT
13	2	618327	3/4MJIC-7/8MOR ADPTR
14	4	824508	410-4 WHL ASSY, 2P STUD
15	4	900128	3/8UNC X 3/4 HEX BOLT
16	10	900129	3/8UNC X 1" HEX BOLT
17	2	900263	1/2UNC X 1" HEX BOLT
18	8	901129	3/8UNC X 1" CARR BOLT
19	12	910004	3/8UNC HEX NUT
20	6	914004	3/8UNC HEX STOVER NUT
21	2	914016	1" UNC HEX STOVER NUT
22	16	920502	3/8 LOCK WASHER
23	1	438419	QUAD PLR SHIELD MT TUBE 91
24	1	438415	QUAD PLR SHIELD WLD 200 91
25	1	438381	RH QUAD PLR STALK GUIDE WLD90
26	1	438384	LH QUAD PLR STALK GUIDE WLD90
27	1	390984	COTTER PIN 1/8 X 1 1/4
28	2	900004	1/4UNC X 1 1/4 HEX BOLT
29	2	914000	1/4UNC HEX STOVER NUT
30	1	438424	QUAD PLR MTR MT PLT WLD
31	2	900064	5/16UNC X 3/4 HEX BOLT
32	1	900830	5/16UNC X 2" HEX BOLT GR8
33	1	914002	5/16UNC HEX STOVER NUT
34	1	473805	ROLL PIN, 1/4 X 1 1/2
35	2	483032	1 1/2 X 1" X .134TH MACH WASH

* NOTE: 1. DETAIL 14 CONSISTS OF:
 824525 - 4 X 2.25 WHEEL & HUB, CARLISLE
 824509 - 4.10/3.50-4 2PLY STUD TIRE
 824513 - STUD, 4-BOLT HUB

2. DETAIL 36 CONSISTS OF:
 824525 - 4 X 2.25 WHEEL & HUB, CARLISLE
 824516 - 4.10/3.50 2P SAWTOOTH TIRE
 824513 - STUD, 4-BOLT HUB

3. DETAIL 43 & 44 ARE USED WITH THE 10-ROW OPTION.

DET.	QTY	PART NO.	DESCRIPTION
36	4	824515	410-4 WHL ASSY, 2P SAWTOOTH
37	4	824525	4 X 2.25 WHEEL & HUB
38	16	824514	WHL NUT, 4-BOLT HUB
39	16	824513	STUD, 4-BOLT HUB
40	4	824509	4.10/3.50-4 2PLY STUD TIRE
41	4	824516	4.10/3.50 2P SAWTOOTH TIRE
42	4	824510	4.10/3.50-4 BENT STEM TUBE
43	1	618586	7/8MOR UNION
44	1	607522	FLOW REGULATOR, 8GPM VONBERG

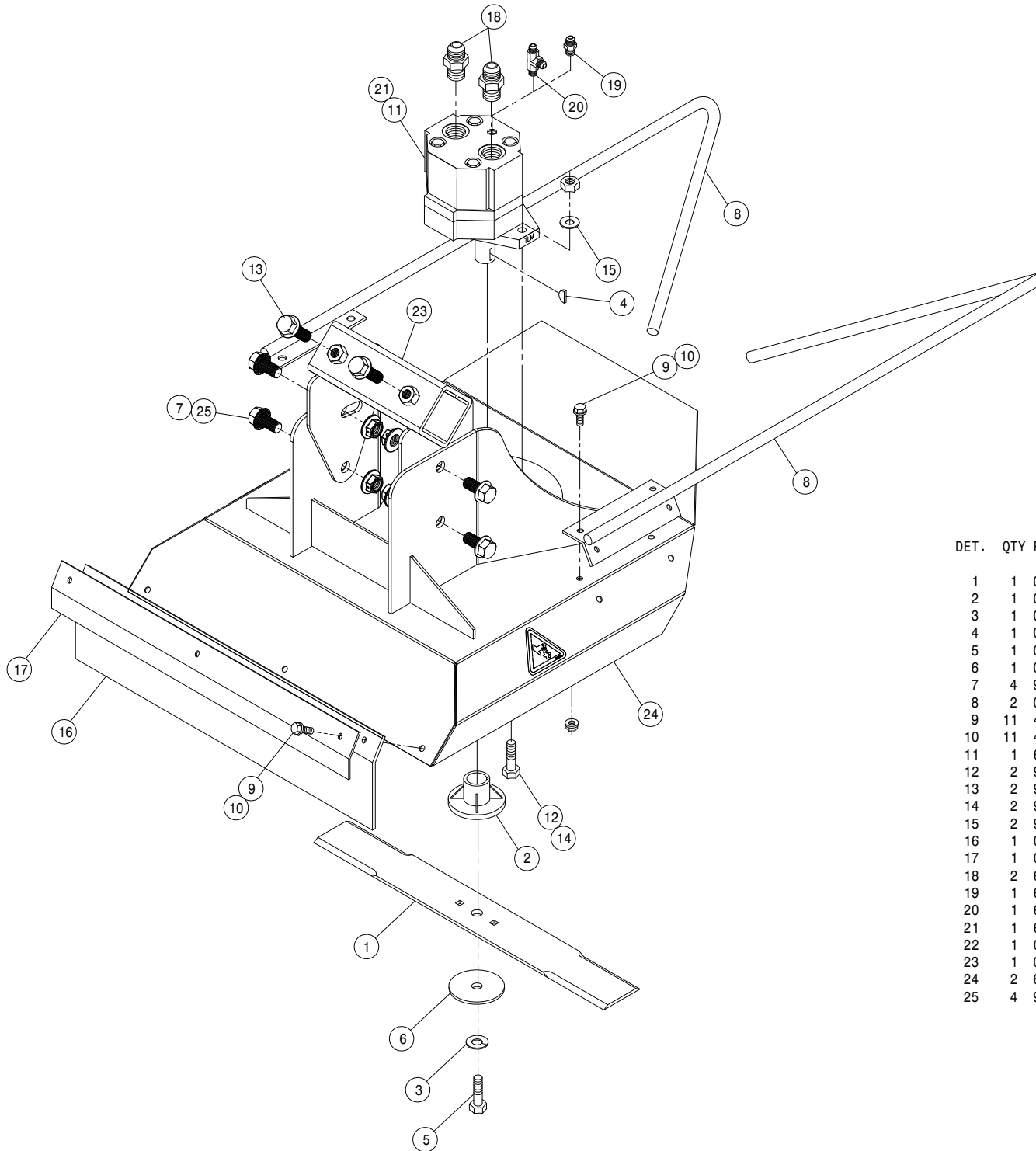

CUTTER HEAD ASSEMBLY

DET. QTY PART NO. DESCRIPTION

DET.	QTY	PART NO.	DESCRIPTION
1	1	002103	CUTR BLADE 18 IN
2	1	002104	CUTTER BLADE ADAPTER, RD LUG
3	1	002105	3/8 LOCK WASHER ZINC PLT
4	1	002106	WOODRUFF KEY # 6, .156 X .625
5	1	002107	3/8UNF X 1 1/2 HEX BOLT CUTR
6	1	002108	STEEL WASHER CUTTER BLADE
7	4	914015	1/2UNC HEX CENTER-LOCK NUT
8	2	002258	19" CUTR STALK GUIDE WLD 04
9	11	470118	1/4UNC X 3/4 FLANGE HEX BOLT
10	11	470121	1/4UNC HEX FLANGE LOCK NUT
11	1	610755	BARNES HYD MOTOR, D-SERIES 01
12	2	900130	3/8UNC X 1 1/4 SER FLANGE BOLT
13	2	900265	1/2UNC X 1 1/2 HEX BOLT
14	2	914004	3/8UNC HEX STOVER NUT
15	2	920002	3/8 SAE FLAT WASHER
16	1	002256	19" REAR CUTR DECK EXT FLAP 04
17	1	002257	19" REAR CUTR DECK FLAP KPR 04
18	2	611125	3/4MJIC-3/4MOR ADPTR
19	1	618530	9/16MJIC-1/8MNPT ADPTR
20	1	618546	1/8MNPT RUN TEE-9/16MJIC
21	1	610756	SEAL, OUTER FOR 610755
22	1	002265	19" ADJ CUTTER HEAD WLD 08
23	1	002269	19" ADJ CUTR HEAD MT WLD 08
24	2	650258	DECAL, CUT FINGERS-ROTATE BLADE
25	4	900263	1/2UNC X 1" HEX BOLT

TWO HEAD ASSEMBLY

THREE HEAD ASSEMBLY

LEFT SIDE OF OPERATOR

RIGHT SIDE OF OPERATOR

LEFT SIDE OF OPERATOR

RIGHT SIDE OF OPERATOR

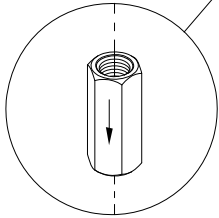
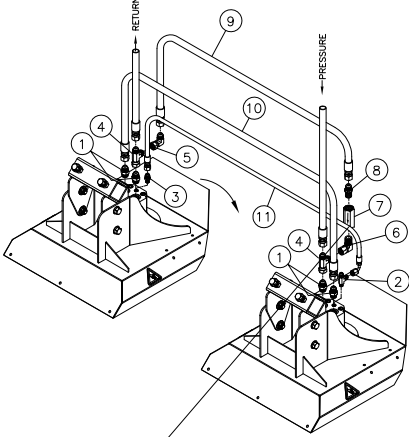
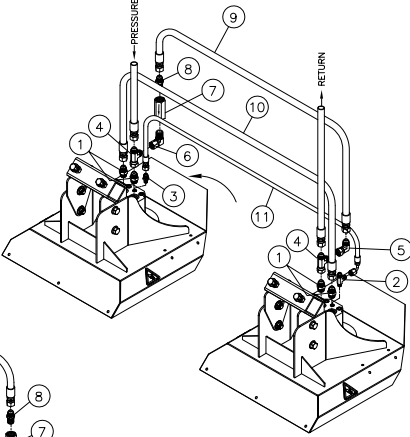
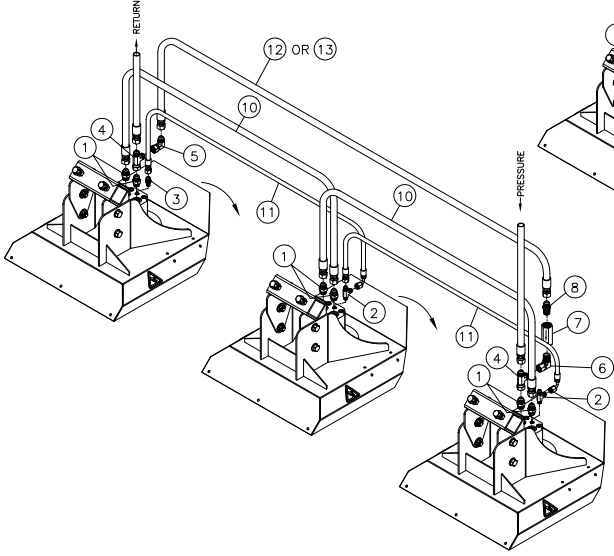
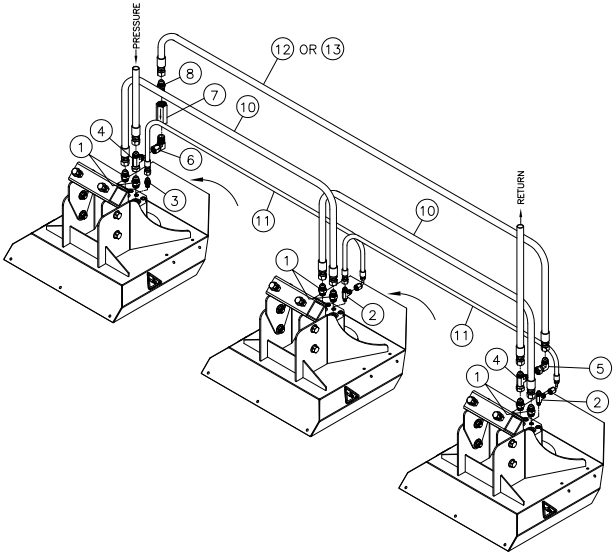

63

HYD SCHEM, CUTTER CHECK VLV 204 07

DET.	QTY	PART NO.	DESCRIPTION
1	611125	3/4MJIC-3/4MOR ADPTR	
2	618546	1/8MNPT RUN TEE-9/16MJIC	
3	618530	9/16MJIC-1/8MNPT ADPTR	
4	618451	3/4FJIC SW RUN TEE-3/4MJIC	
5	618609	3/4MJIC-90-3/4FJIC SWIV LBO	
6	618620	3/4FJX-90-1/2MNPT ADPTR	
7	690338	LINE CHECK VALVE HYD .50NPT	
8	611147	3/4MJIC-1/2MNPT ADPTR	
9	616025	08C1T-08FJX-08FJX-50	H/A
10	614368	08C1T-08FJX-08FJX-60	H/A
11	616422	04C1T-06FJX-06FJX90-50	H/A
12	616031	08C1T-08FJX-08FJX-83	H/A
13	614662	08C1T-08FJX-08FJX-72	H/A

DET REQ	DESCRIPTION		
	 HAGIE MANUFACTURING COMPANY CLARION, IOWA 50525		
REMOVE ALL SHARP CORNERS & BURRS			
TOLERANCE UNLESS OTHERWISE SPECIFIED			
FRACTION ±1/32	DECIMALS X.XX ±.03	ANGLES ±1°	
DESCRIPTION: HYD SCHEM, CUTTER CHECK VLV 204 07			
DRAWN BY: T. MARKER		SCALE: FULL	
CHECKED BY:		APPROVED BY:	
DATE: 05-16-07	DRAWING NUMBER: 498929		
SHEET: OF			

488063

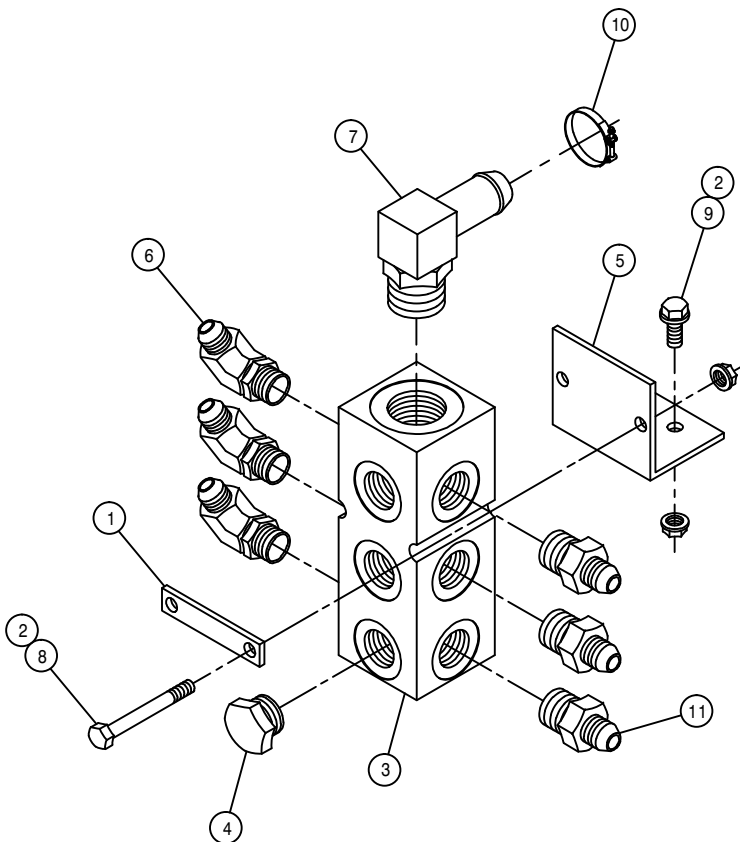

CUTTER CASE DRAIN MANIFOLD ASSEMBLY

DET. QTY PART NO. DESCRIPTION

1	1	438729	CUTTER RETURN MANIF MT KEEPER
2	4	470121	1/4UNC HEX FLANGE LOCK NUT
3	1	606021	HYD RETURN MANIF,3/4FOR,9-PORT
4	3	611159	3/4MOR PLUG, HEX HEAD
5	1	615755	204 CASE DRAIN MANIFOLD MT O2
6	3	618115	9/16MJIC-90-3/4MOR LBO
7	1	618118	3/4 HOSE BARB-90-1 1/16MOR
8	2	900009	1/4UNC X 2 3/4 HEX BOLT
9	2	470118	1/4UNC X 3/4 FLANGE HEX BOLT
10	1	520154	1.06/1.19 T-BOLT HOSE CLAMP SS
11	3	618109	9/16MJIC-3/4MOR ADPTR

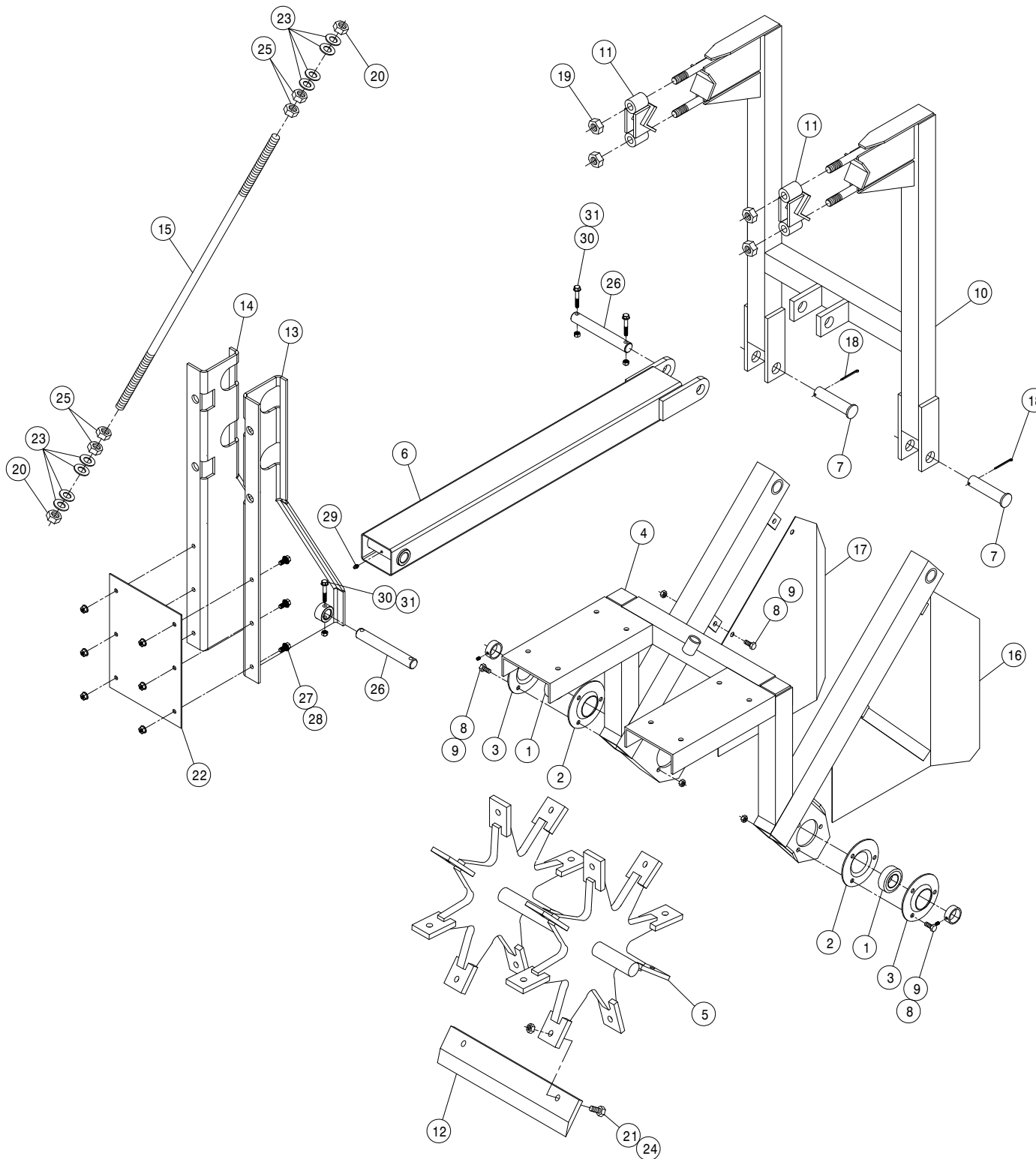

15" MALE ROW CHOPPER ASSEMBLY

DET.	QTY	PART NO.	DESCRIPTION
1	2	123024	BGR 1 1/4 BORE SPHERICL RELUB
2	2	123026	FLANGETT 1 1/4
3	2	123035	FLANGETT 1 1/4 180 DEG ZERK
4	1	270814	LWR FRAME WLD MALE ROW CHOP
5	1	270860	BLADE MT WHL WLD, CHOPPER 92
6	1	270937	LWR LIFTARM WLDMT,MALE CHOP 09
7	2	472012	CLEVIS PIN, 1.00 X 3.25 PLT
8	10	900129	3/8UNC X 1" SERR FLANGE BOLT
9	10	914004	3/8UNC HEX STOVER NUT
10	1	270855	UPR FRAME WLD MALE ROW CHOP91
11	2	270833	TOOL BAR CLAMP WLD MALE CHOP
12	8	270838	CHOPPER BLADE, MALE ROW, 15"
13	1	270940	RH LWR LIFTARM MT WLD,CHOP 09
14	1	270941	LH LWR LIFTARM MT WLD,CHOP 09
15	1	270844	ADJ ROD MALE ROW CHOPPER
16	1	270845	RH SHLD WLD MALE ROW CHOPPER
17	1	270846	LH SHLD WLD MALE ROW CHOPPER
18	2	470162	COTTER PIN 3/16 X 1 1/2 SQCUT
19	4	914010	5/8UNC HEX STOVER NUT
20	2	914012	3/4UNC HEX STOVER NUT
21	16	900265	1/2UNC X 1 1/2 HEX BOLT
22	1	270944	LWR LIFTARM MT TIE PLT,CHOP 09
23	8	920006	3/4 SAE FLAT WASHER
24	16	914008	1/2UNC HEX STOVER NUT
25	4	910012	3/4UNC HEX NUT
26	2	270945	LWR LIFTARM PIN,MALE CHOP 09
27	6	470087	3/8UNC HEX FLANGE LOCK NUT
28	6	470409	3/8UNC X 3/4 SERR FLANGE BOLT
29	1	471005	GREASE ZERK, 1/4 28 X 1/2
30	4	900069	5/16UNC X 2" HEX BOLT
31	4	914002	5/16UNC HEX STOVER NUT

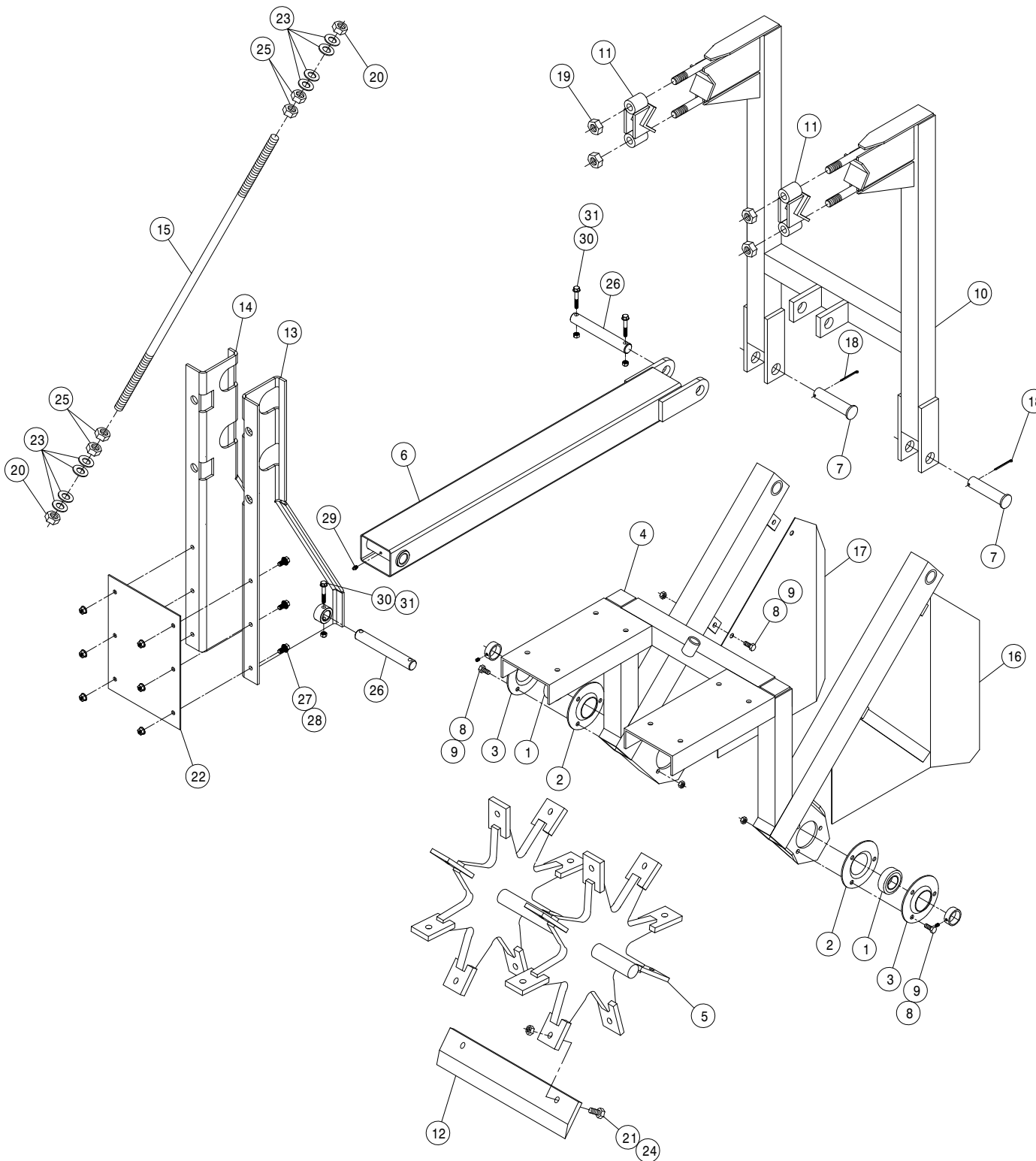

20" MALE ROW CHOPPER ASSEMBLY

DET.	QTY	PART NO.	DESCRIPTION
1	2	123024	BGR 1 1/4 BORE SPHERICL RELUB
2	2	123026	FLANGETT 1 1/4
3	2	123035	FLANGETT 1 1/4 180 DEG ZERK
4	1	270872	LWR FRAME WLD,20"MALE CHOPR95
5	1	270874	BLADE MT WHL WLD,20"CHOPR 95
6	1	270937	LWR LIFTARM WLDMT,MALE CHOP 09
7	2	472012	CLEVIS PIN, 1.00 X 3.25 PLT
8	10	900129	3/8UNC X 1" SERR FLANGE BOLT
9	10	914004	3/8UNC HEX STOVER NUT
10	1	270876	UPR FRAME WLD,20"MALE CHOPR95
11	2	270833	TOOL BAR CLAMP WLD MALE CHOP
12	8	270866	CHOPPER BLADE, MALE ROW, 20"
13	1	270940	RH LWR LIFTARM MT WLD,CHOP 09
14	1	270941	LH LWR LIFTARM MT WLD,CHOP 09
15	1	270867	ADJ ROD WLD,MALE ROW CHOPR 95
16	1	270845	RH SHLD WLD MALE ROW CHOPPER
17	1	270846	LH SHLD WLD MALE ROW CHOPPER
18	2	470162	COTTER PIN 3/16 X 1 1/2 SQ CUT
19	4	914010	5/8UNC HEX STOVER NUT
20	2	914012	3/4UNC HEX STOVER NUT
21	16	900265	1/2UNC X 1 1/2 HEX BOLT
22	1	270944	LWR LIFTARM MT TIE PLT,CHOP 09
23	8	920006	3/4 SAE FLAT WASHER
24	16	914008	1/2UNC HEX STOVER NUT
25	4	910012	3/4UNC HEX NUT
26	2	270945	LWR LIFTARM PIN,MALE CHOP 09
27	6	470087	3/8UNC HEX FLANGE LOCK NUT
28	6	470409	3/8UNC X 3/4 SERR FLANGE BOLT
29	1	471005	GREASE ZERK, 1/4 28 X 1/2
30	4	900069	5/16UNC X 2" HEX BOLT
31	4	914002	5/16UNC HEX STOVER NUT

2-LIFT, DEPTH COMMAND SWITCH ASSEMBLY

DET. QTY PART NO. DESCRIPTION

1	1	002744	SWITCH BOX, DEPTH CMD
2	1	003096	SWITCH BOX MT, DEPTH CMD 08
3	1	291602	FUSE 10 AMP
4	2	293172	TOGGLE SWITCH DPDT W/JUMPERS
5	1	298011	FUSE HOLDER
6	2	470001	RUBBER BOOT W NUT FOR 298012
7	4	473829	3MM-0.50 X 16MM PANHEAD SCREW
8	1	473914	RUBBER GROMMET 9/16 ID
9	1	650308	DECAL, LEFT L-CTR R-CTR RIGHT
10	2	658174	BUMPER PLUG FOR 1/2 HOLE

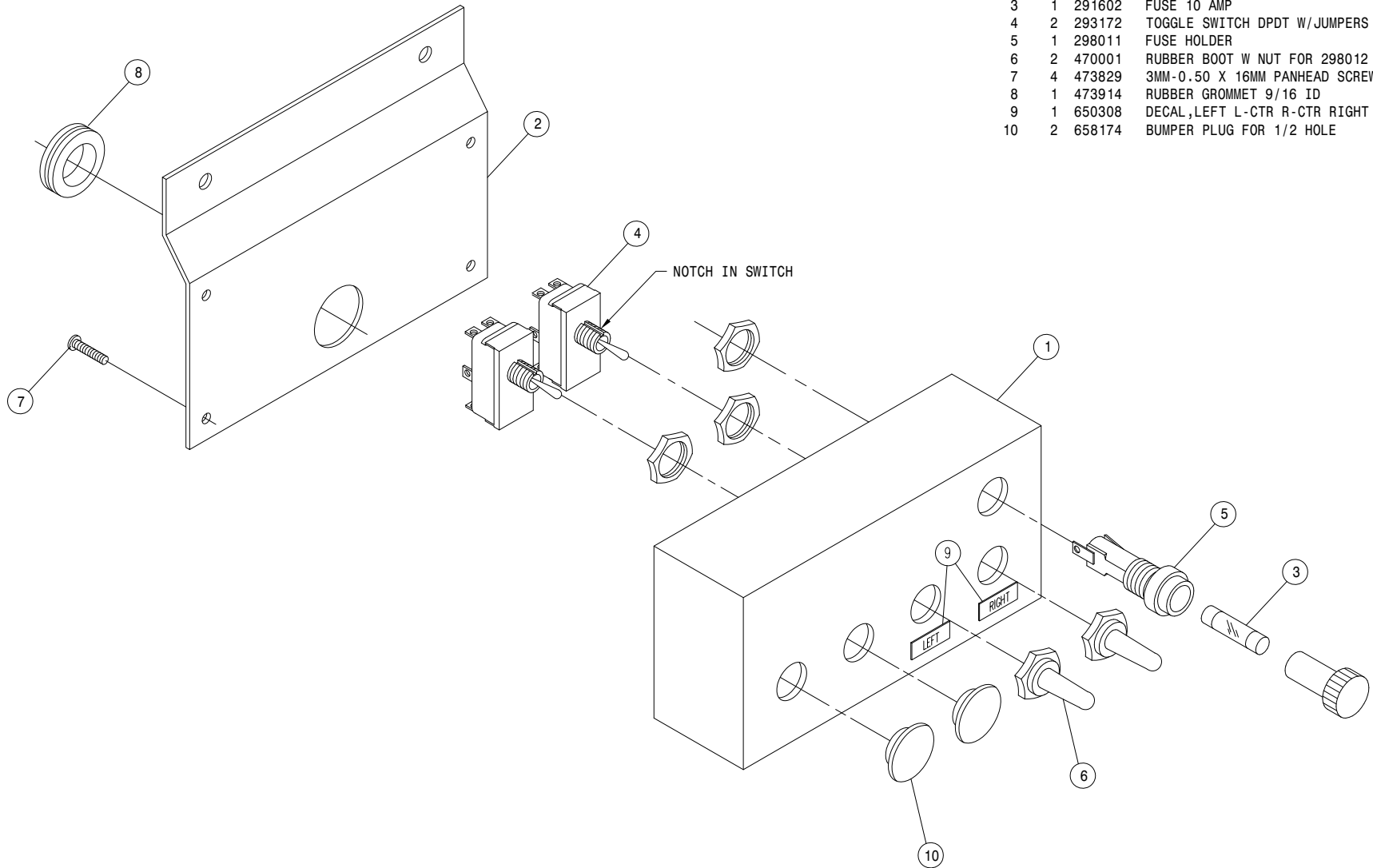

3-LIFT, DEPTH COMMAND SWITCH ASSEMBLY

DET. QTY PART NO. DESCRIPTION

DET.	QTY	PART NO.	DESCRIPTION
1	1	002744	SWITCH BOX, DEPTH CMD
2	1	003096	SWITCH BOX MT, DEPTH CMD 08
3	1	291602	FUSE 10 AMP
4	3	293172	TOGGLE SWITCH DPDT W/JUMPERS
5	1	298011	FUSE HOLDER
6	3	470001	RUBBER BOOT W NUT FOR 298012
7	4	473829	3MM-0.50 X 16MM PANHEAD SCREW
8	1	473914	RUBBER GROMMET 9/16 ID
9	1	650308	DECAL, LEFT L-CTR R-CTR RIGHT
10	1	658174	BUMPER PLUG FOR 1/2 HOLE

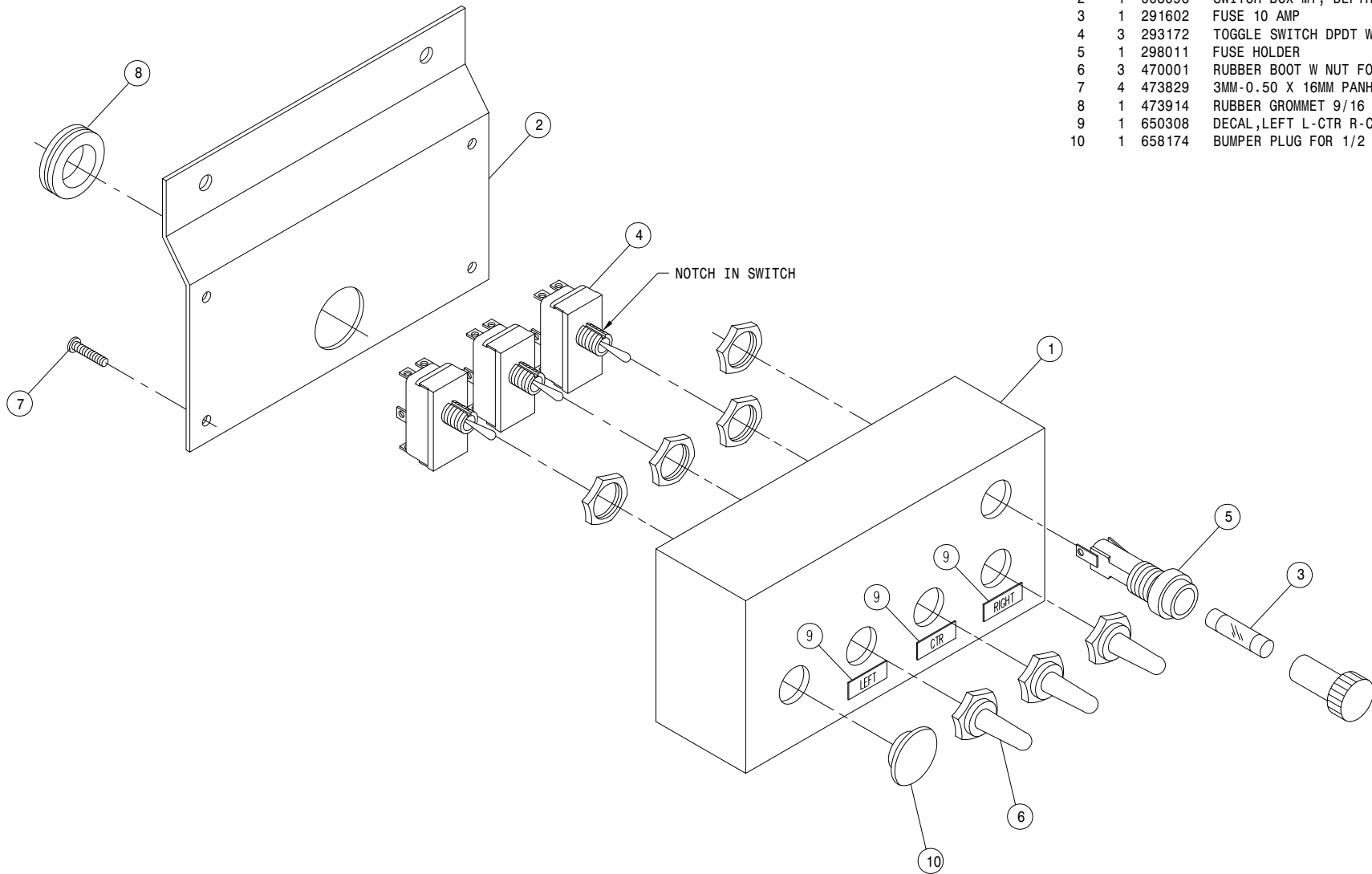

4-LIFT, DEPTH COMMAND SWITCH ASSEMBLY

DET. QTY PART NO. DESCRIPTION

DET.	QTY	PART NO.	DESCRIPTION
1	1	002744	SWITCH BOX, DEPTH CMD
2	1	003096	SWITCH BOX MT, DEPTH CMD 08
3	1	291602	FUSE 10 AMP
4	4	293172	TOGGLE SWITCH DPDT W/JUMPERS
5	1	298011	FUSE HOLDER
6	4	470001	RUBBER BOOT W NUT FOR 298012
7	4	473829	3MM-0.50 X 16MM PANHEAD SCREW
8	1	473914	RUBBER GROMMET 9/16 ID
9	1	DECAL, LEFT L-CTR R-CTR RIGHT	

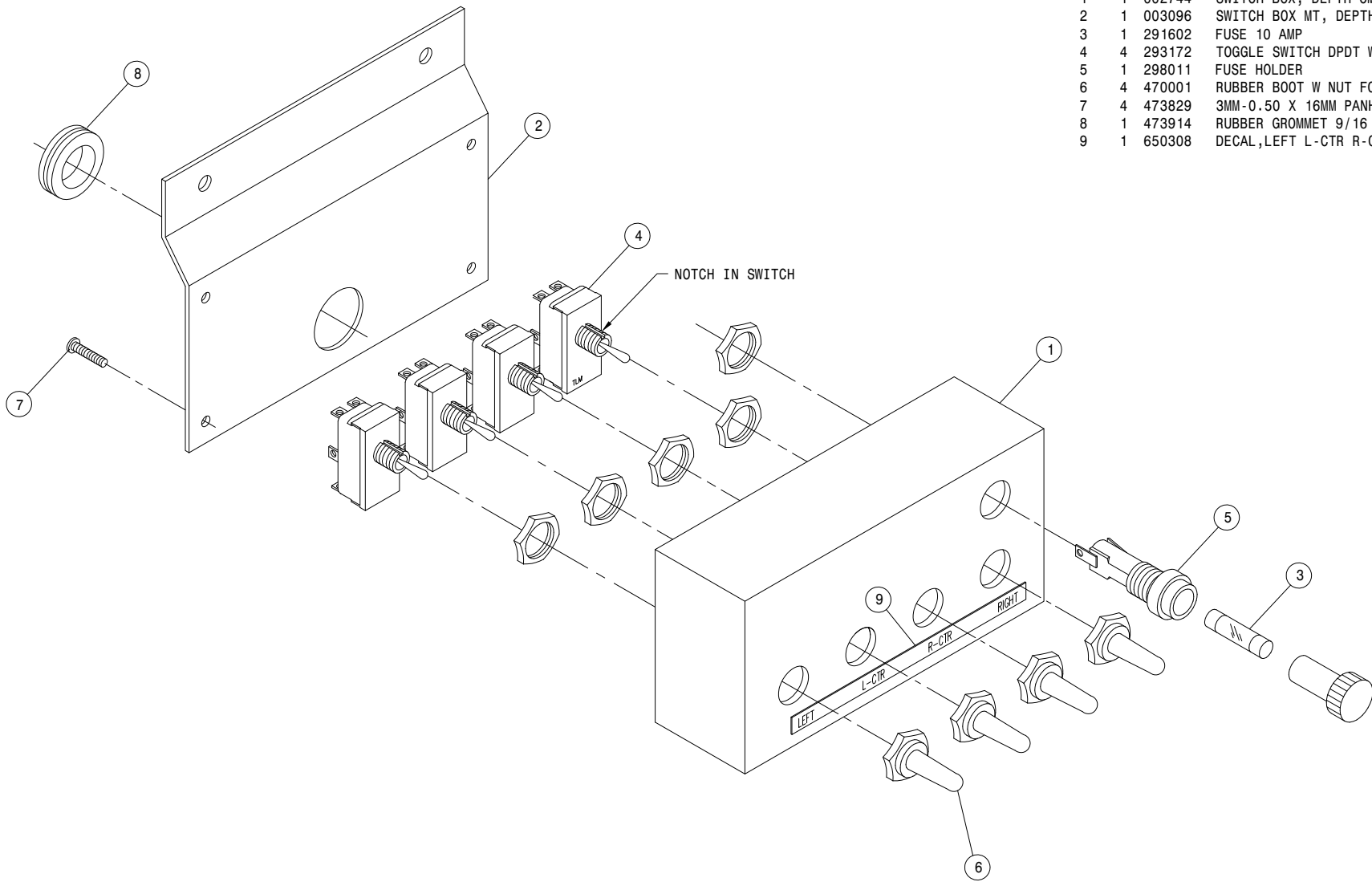

6-LIFT, DEPTH COMMAND SWITCH ASSEMBLY

DET. QTY PART NO. DESCRIPTION

1	1	002896	SWITCH BOX, 5/6L DEPTH CMD 96
2	1	002897	SWITCH BOX MT, 5/6L DEPTH CMD
3	1	291602	FUSE 10 AMP
4	6	293172	TOGGLE SWITCH DPDT W/JUMPERS
5	1	298011	FUSE HOLDER
6	6	470001	RUBBER BOOT W NUT FOR 298012
7	4	473829	3MM-0.50 X 16MM PANHEAD SCREW
8	1	473914	GROMMET, .562ID .062GW .812GD
9	1	650338	DECAL, DEPTH CMD 6-LIFT

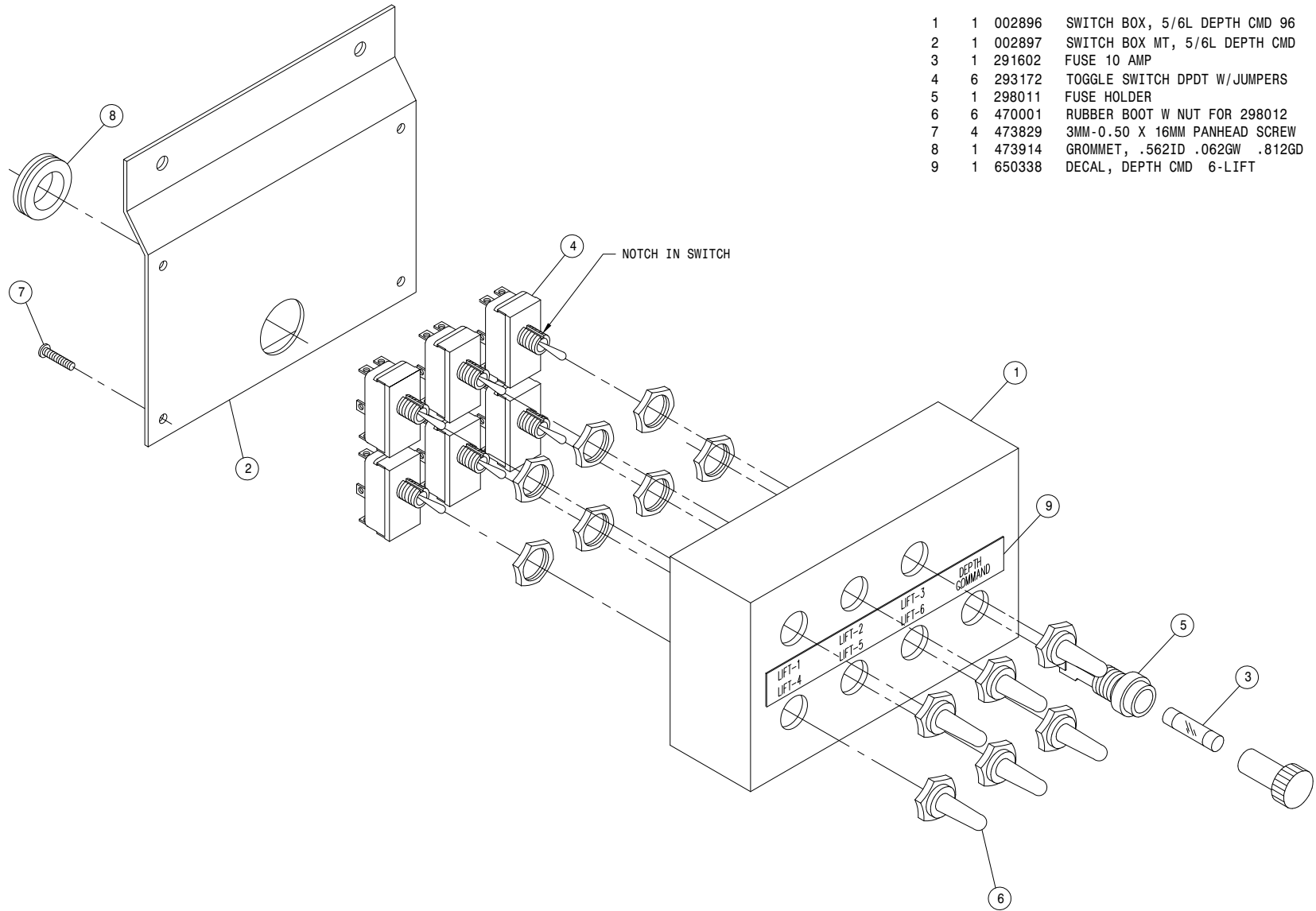

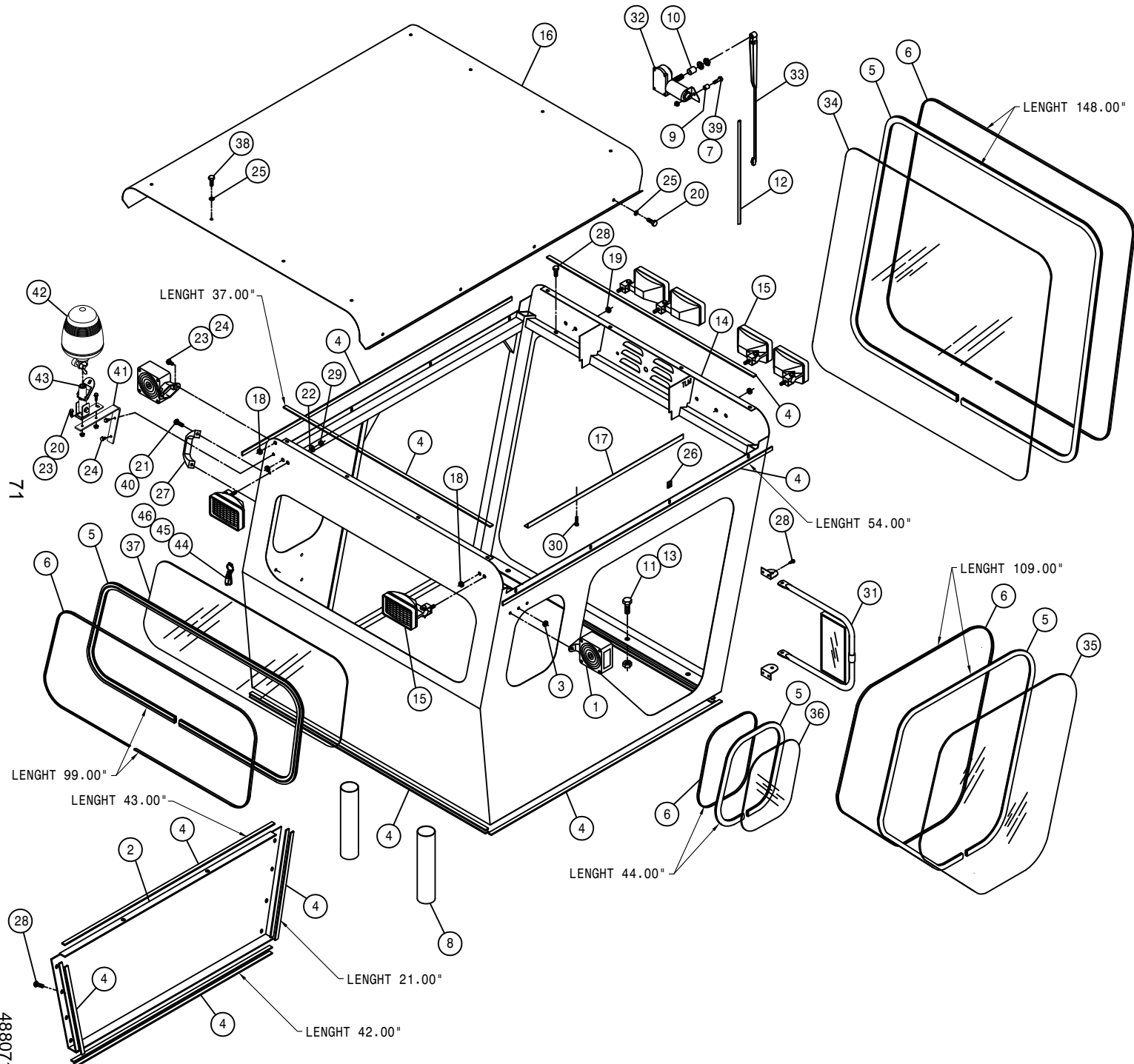

CAB ASSEMBLY

DET.	QTY	PART NO.	DESCRIPTION
1	2	291604	TURN SIGNAL LIGHT,PED MT, YEL
2	1	342295	LH SIDE PANEL, 204 CAB 95
3	2	470226	GROMMET, .156ID .062GW .250GD
4	46	193037	STICKERTITE 1/8 X 3/4
5	42	193044	WINDOW WEATHERSTRIP
6	42	193045	LOCK STRIP FOR 193044
7	1	914000	1/4UNC HEX STOVER NUT
8	2	342333	NYL HOSE SLEEVE,2.64ID X 12.00
9	1	200019	.250 SCH40 BP X 1.00 C/L
10	1	202037	WINDSHIELD WIPER SPACER
11	6	900264	1/2UNC X 1 1/4 HEX BOLT
12	1	290417	18" WIPER BLADE
13	6	914008	1/2UNC HEX STOVER NUT
14	1	342287	204 CAB WELDMT 95
15	6	291603	HALOGEN WORKLAMP,SIDE MT 12V
16	1	342150	CAB ROOF WLD, 284 94
17	1	342180	HEADLINER KPR ANGLE,284CAB 94
18	3	470067	GROMMET, .250ID .125GW .375GD
19	2	470070	GROMMET, .375ID .062GW .500GD
20	10	470118	1/4UNC X 3/4 SER FLG BOLT
21	2	903883	10-32 X 1/2 PHIL PAN MACH SCR
22	6	470100	3/8 INT TOOTH LOCK WASHER
23	6	470121	1/4UNC SER FLG LOCK NUT
24	6	470122	1/4UNC X 1/2 SER FLG BOLT
25	16	470514	1/4 X 1 SEALING WASHER
26	16	470218	1/4UNC NUT J-TYPE CAGE CLIP
27	1	470222	GRAB HANDLE, BLACK MOULDED
28	22	472349	1/4 X 3/4 20THD-IN TEK TYPE
29	6	473779	10MM-1.50 HEX NUT
30	2	473910	1/4 X 1 1/2 PHILHD SHT MTL SCR
31	2	650524	OUTSIDE MIRROR W/MT BRKT(PAIR)
32	1	658008	WINDSHIELD WIPER MOTOR
33	1	658013	WIPER ARM
34	1	658018	FRONT CAB GLASS, 204 95
35	1	658015	FRONT SIDE CAB/DOOR GLASS 94
36	2	658016	REAR SIDE CAB GLASS 94
37	1	658017	REAR CAB GLASS 94
38	8	900002	1/4UNC X 3/4 HEX BOLT
39	1	900005	1/4UNC X 1 1/2 HEX BOLT
40	2	470175	10-32 SER FLG NUT
41	1	343839	BEACON MT BRKT 204SP' 10
42	1	290059	BEACON,12V AMBER HALOGEN
43	1	290060	BEACON TILT SURFACE MT,QK CHG
44	1	470397	RES-Q-ME TOOL
45	1	470398	BEAD CHAIN, #10 X 4" LONG
46	1	470399	BEAD CHAIN, #10 RD BRASS 10'

71

488071

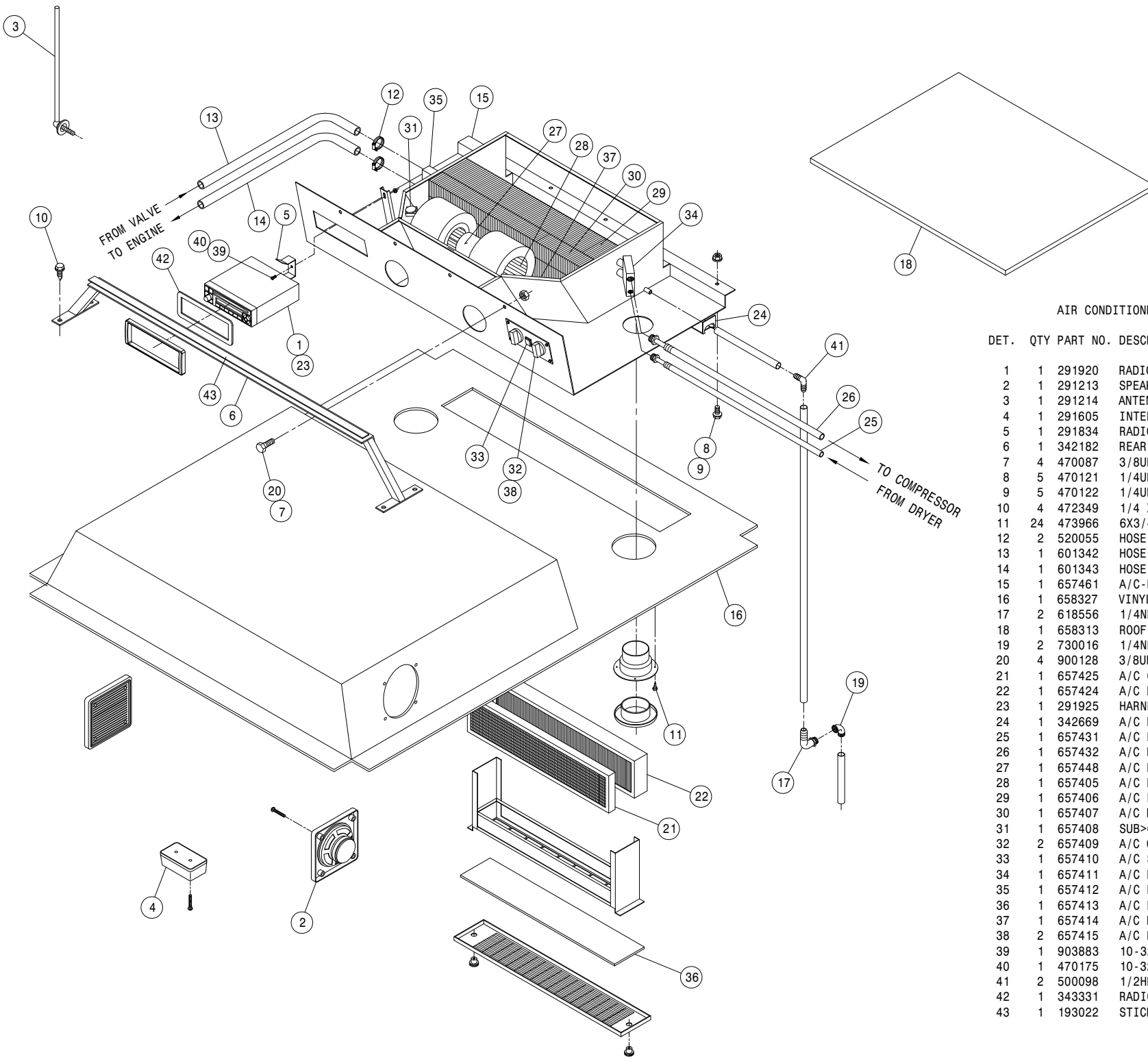

AIR CONDITIONER ASSEMBLY

DET.	QTY	PART NO.	DESCRIPTION
1	1	291920	RADIO CRW200
2	1	291213	SPEAKERS (PAIR)
3	1	291214	ANTENNA
4	1	291605	INTERIOR LIGHT W/SWITCH
5	1	291834	RADIO SUPPORT BRKT
6	1	342182	REAR A/C BLOWER MT WLD,CAB 94
7	4	470087	3/8UNC HEX FLANGE LOCK NUT
8	5	470121	1/4UNC HEX FLANGE LOCK NUT
9	5	470122	1/4UNC X 1/2 FLANGE HEX BOLT
10	4	472349	1/4 X 3/4 20THD-IN TEK TYPE
11	24	473966	6X3/4 PHIL FLT HD SHT MTL SCR
12	2	520055	HOSE CLAMP NO 12 STAINLESS
13	1	601342	HOSE, 5/8 X 192 HEATER
14	1	601343	HOSE, 5/8 X 216 HEATER
15	1	657461	A/C-HTR BLOWER SYS, DTS8 05
16	1	658327	VINYL HEAD LINER 99
17	2	618556	1/4NPT-90-1/2 HOSE BARB,POLY
18	1	658313	ROOF SEAL,AIR COND 204,254,284
19	2	730016	1/4NPT ST EL, 90 DEG POLY
20	4	900128	3/8UNC X 3/4 HEX BOLT
21	1	657425	A/C CHARCOAL AIR FILTER
22	1	657424	A/C PAPER AIR FILTER
23	1	291925	HARNES, RADIO CRW200 DTS 05
24	1	342669	A/C DRAIN HOSE KEEPER
25	1	657431	A/C HOSE ASSY, 5/16 X 173
26	1	657432	A/C HOSE ASSY, 1/2 X 190.
27	1	657448	A/C BLOWER ASSY, 12V KENWAY
28	1	657405	A/C BLOWER WHEEL W/CLIP
29	1	657406	A/C EVAPORATOR COIL
30	1	657407	A/C HEATER COIL
31	1	657408	SUB>657468:A/C THERMOSTAT
32	2	657409	A/C CONTROL KNOB
33	1	657410	A/C SWITCH, PUSH ON-OFF
34	1	657411	A/C EXPANSION VALVE
35	1	657412	A/C HEATER VALVE,4-WAY MTRIZED
36	1	657413	A/C FILTER,RECIRCULATION 30"
37	1	657414	A/C BLOWER DRIVE ASSY
38	2	657415	A/C POTENTIOMETER ASSY
39	1	903883	10-32 X 1/2 SLT RDHD MACH SCR
40	1	470175	10-32 HEX FLANGE LOCK NUT
41	2	500098	1/2HB-90-1/2 HOSE BARB, POLY
42	1	343331	RADIO BEZEL,CAB, BLK PLASIC 05
43	1	193022	STICKERTITE 1/4 X 3/4

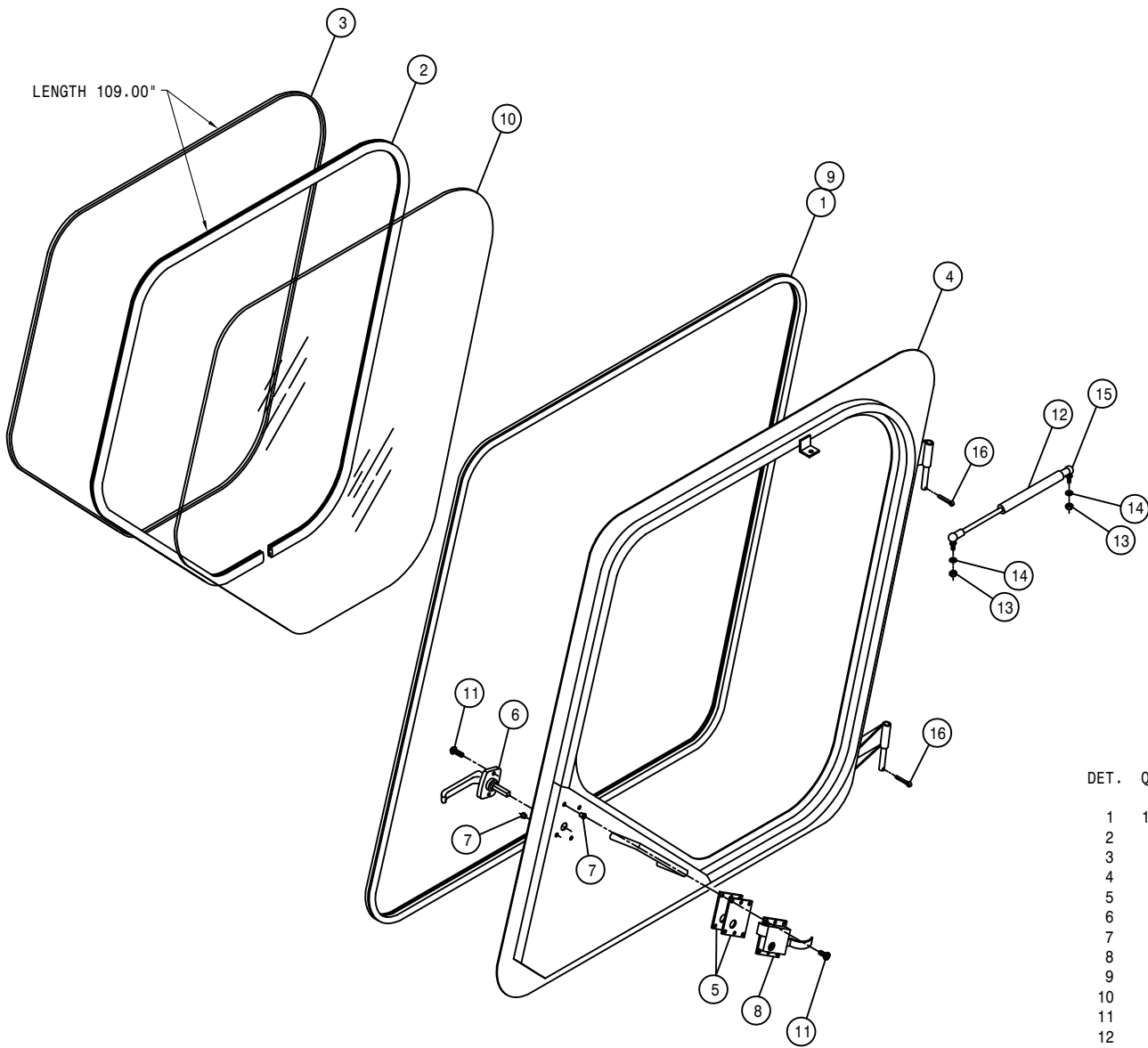

DOOR ASSEMBLY

DET.	QTY	PART NO.	DESCRIPTION
1	12	193028	PUSH-ON TRIM SEAL RS-130-FX
2	9	193044	WINDOW WEATHERSTRIP
3	9	193045	LOCK STRIP FOR 193044
4	1	342153	LH DOOR WLD, 284 CAB 94
5	2	342163	CAB DOOR LATCH SHIM, .06 94
6	1	342217	DOOR HANDLE, 254/284 CAB 94
7	6	470384	10-32 NUTSERT .020-.130 STL
8	1	470219	CAB LOCK, LH #55
9	2	485052	POP RIVET 1/8 X 3/8
10	1	658015	FRONT SIDE CAB/DOOR GLASS 94
11	6	903710	10-32X5/8 PHIL PANHD MACH SCR
12	1	470221	GAS SPRING, 60LB 3.5 STROKE
13	2	910002	5/16UNC HEX NUT
14	2	920501	5/16 LOCK WASHER
15	2	470255	BALL STUD, 5/16-18 THD X 10MM
16	2	470006	COTTER PIN 1/8 X 1

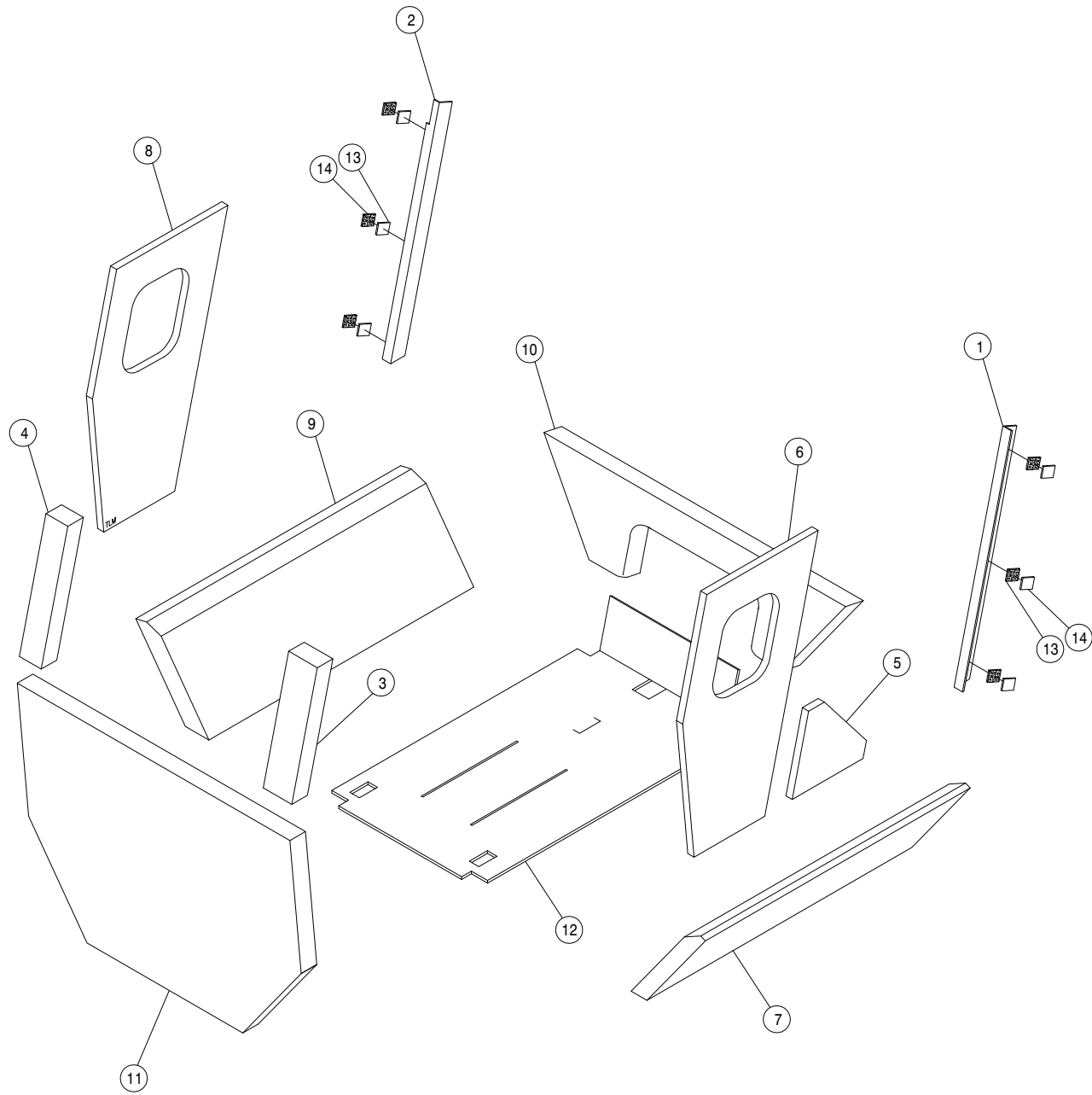

CAB FOAM

DET.	QTY	PART NO.	DESCRIPTION
1	1	658301	VINYL POST COVER, RH FRONT 94
2	1	658302	VINYL POST COVER, LH FRONT 94
3	1	658303	VINYL POST COVER, RH REAR 94
4	1	658304	VINYL POST COVER, LH REAR 94
5	1	658305	VINYL SIDE PANEL, RH 94
6	1	658306	VINYL SIDE PANEL, RH UPPER 94
7	1	658307	VINYL SIDE PANEL, RH LOWER 94
8	1	658308	VINYL SIDE PANEL, LH UPPER 94
9	1	658309	VINYL SIDE PANEL, LH LOWER 94
10	1	658310	VINYL FRONT COVER PANEL 94
11	1	658311	VINYL REAR COVER PANEL 94
12	1	658316	CAB FLOORMAT, 284 97
13	6	471101	DUAL LOCK, 1.00 X 1.00 SJ3542
14	6	471100	DUAL LOCK, 1.00 X 1.00 SJ3541

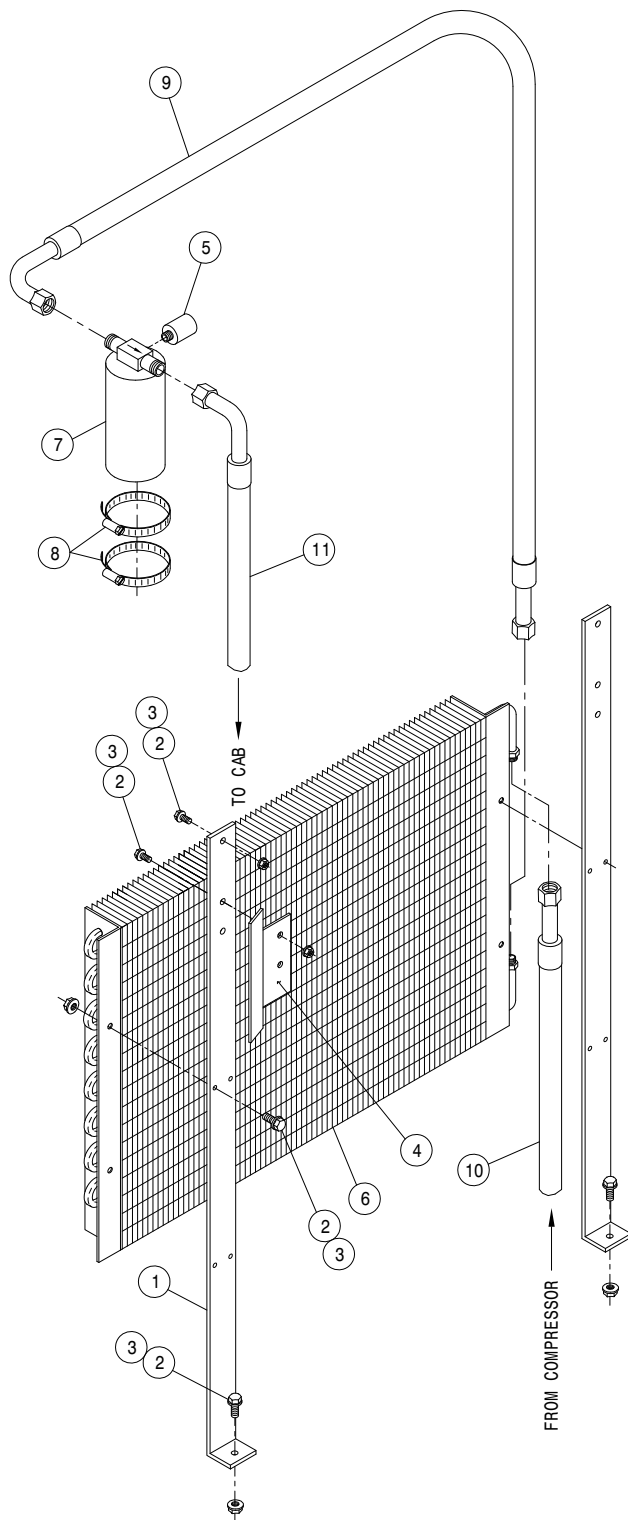

A/C CONDENSOR ASSEMBLY

DET.	QTY	PART NO.	DESCRIPTION		
	1	2	315036	CONDENSER MTG BRKT	99
	2	10	470118	1/4UNC X 3/4 FLANGE HEX BOLT	
	3	10	470121	1/4UNC HEX FLANGE LOCK NUT	
	4	1	315038	A/C DRIER MT,204-254-284	99
	5	1	657422	A/C BINARY SWITCH	
	6	1	657423	A/C CONDENSER COIL 21-0324	
	7	1	657421	A/C RECEIVER/DRIER	
	8	2	520052	HOSE CLAMP NO 52 STAINLESS	
	9	1	657429	A/C HOSE ASSY, 5/16 X 44	
	10	1	657430	A/C HOSE ASSY, 13/32 X 80	
	11	1	657431	A/C HOSE ASSY, 5/16 X 173	

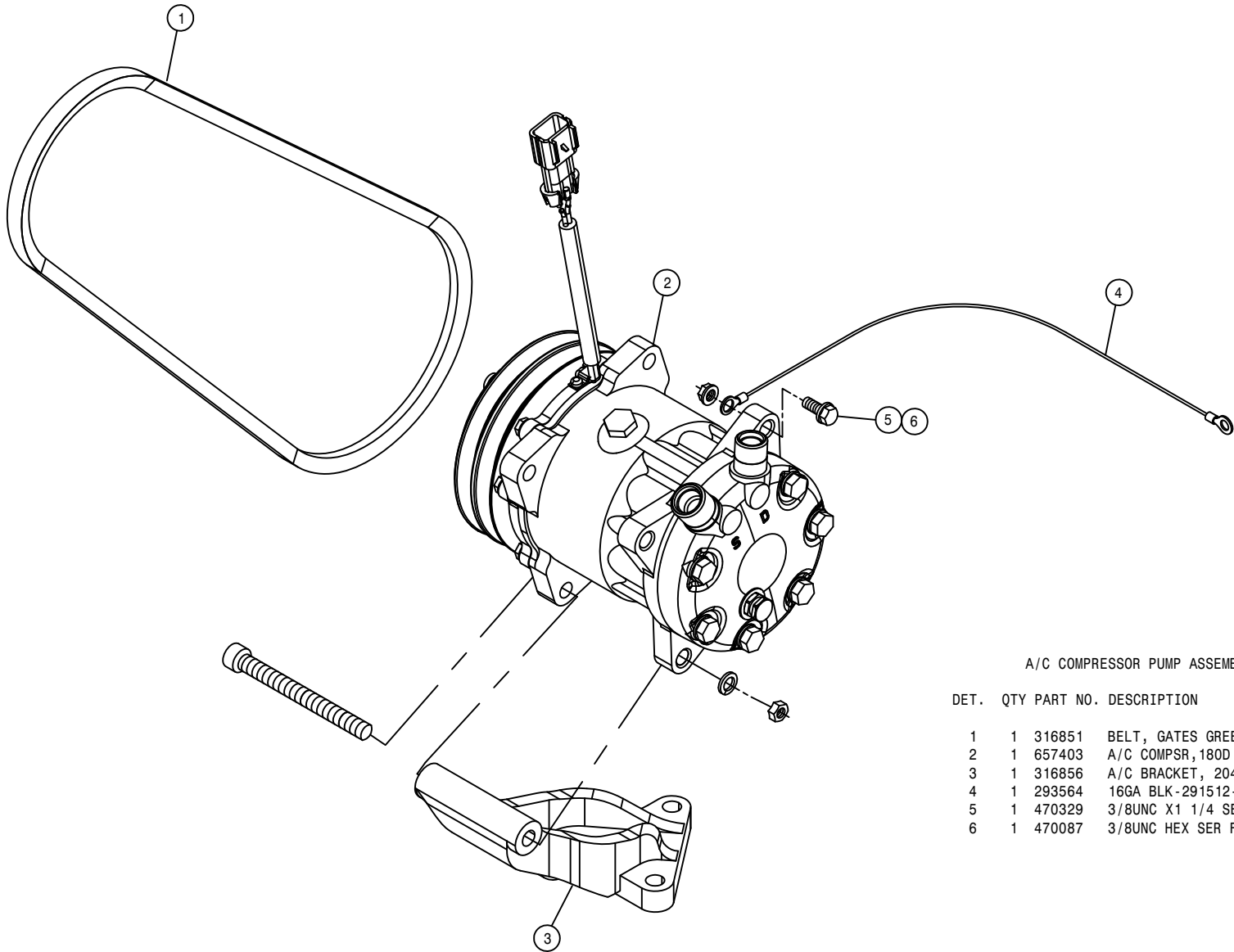

A/C COMPRESSOR PUMP ASSEMBLY

DET.	QTY	PART NO.	DESCRIPTION
	1	316851	BELT, GATES GREEN STRIPE 9447
	1	657403	A/C COMPSR, 180D PORTS TM15/12
	1	316856	A/C BRACKET, 204SP/DTS10
	1	293564	16GA BLK-291512-291590-36
	1	470329	3/8UNC X 1 1/4 SER FLG HEX BOLT
	1	470087	3/8UNC HEX SER FLG NUT

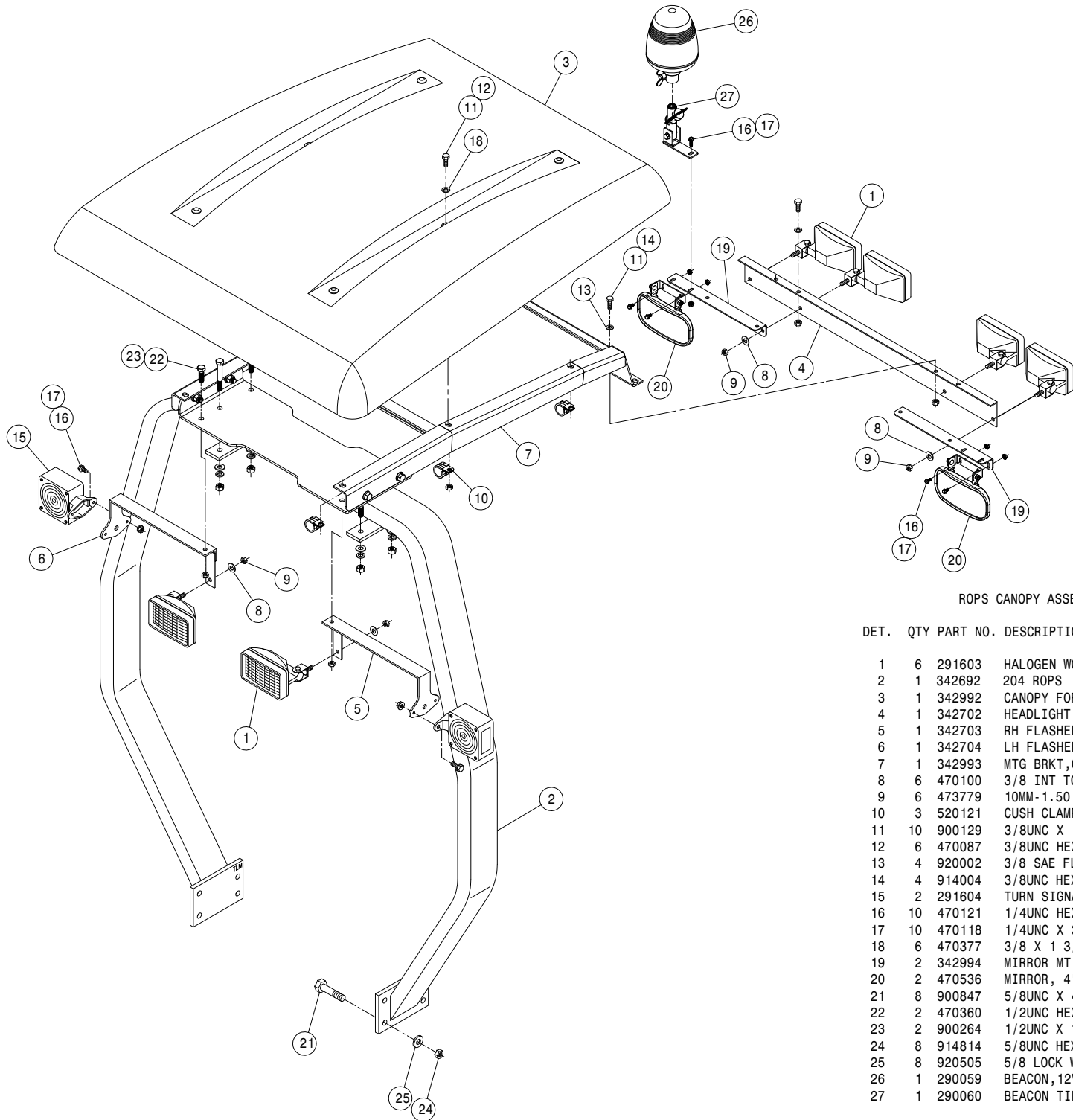

ROPS CANOPY ASSEMBLY

DET.	QTY	PART NO.	DESCRIPTION
	6	291603	HALOGEN WORKLAMP, SIDE MT 12V
	1	342692	204 ROPS
	1	342992	CANOPY FOR 204/SP ROPS 08
	1	342702	HEADLIGHT MT, 204 ROPS 2000
	1	342703	RH FLASHER MT WLD, 204 ROPS 2000
	1	342704	LH FLASHER MT WLD, 204 ROPS 2000
	1	342993	MTG BRKT, CANOPY 204/SP ROPS 08
	6	470100	3/8 INT TOOTH LOCK WASHER
	6	473779	10MM-1.50 HEX NUT
	3	520121	CUSH CLAMP, #16 1IN X 3/4W
	10	900129	3/8UNC X 1" SERR FLANGE BOLT
	6	470087	3/8UNC HEX FLANGE LOCK NUT
	4	920002	3/8 SAE FLAT WASHER
	4	914004	3/8UNC HEX STOVER NUT
	2	291604	TURN SIGNAL LIGHT, PED MT, YEL
	10	470121	1/4UNC HEX FLANGE LOCK NUT
	10	470118	1/4UNC X 3/4 FLANGE HEX BOLT
	6	470377	3/8 X 1 3/16 BONDED SS WASHER
	2	342994	MIRROR MT, 204 CANOPY 08
	2	470536	MIRROR, 4" X 8" CONVEX
	8	900847	5/8UNC X 4 1/2 HEX BOLT GR8
	2	470360	1/2UNC HEX FLANGE LOCK NUT
	2	900264	1/2UNC X 1 1/4 HEX BOLT
	8	914814	5/8UNC HEX NUT GR8
	8	920505	5/8 LOCK WASHER
	1	290059	BEACON, 12V AMBER HALOGEN
	1	290060	BEACON TILT SURFACE MT, QK CHG

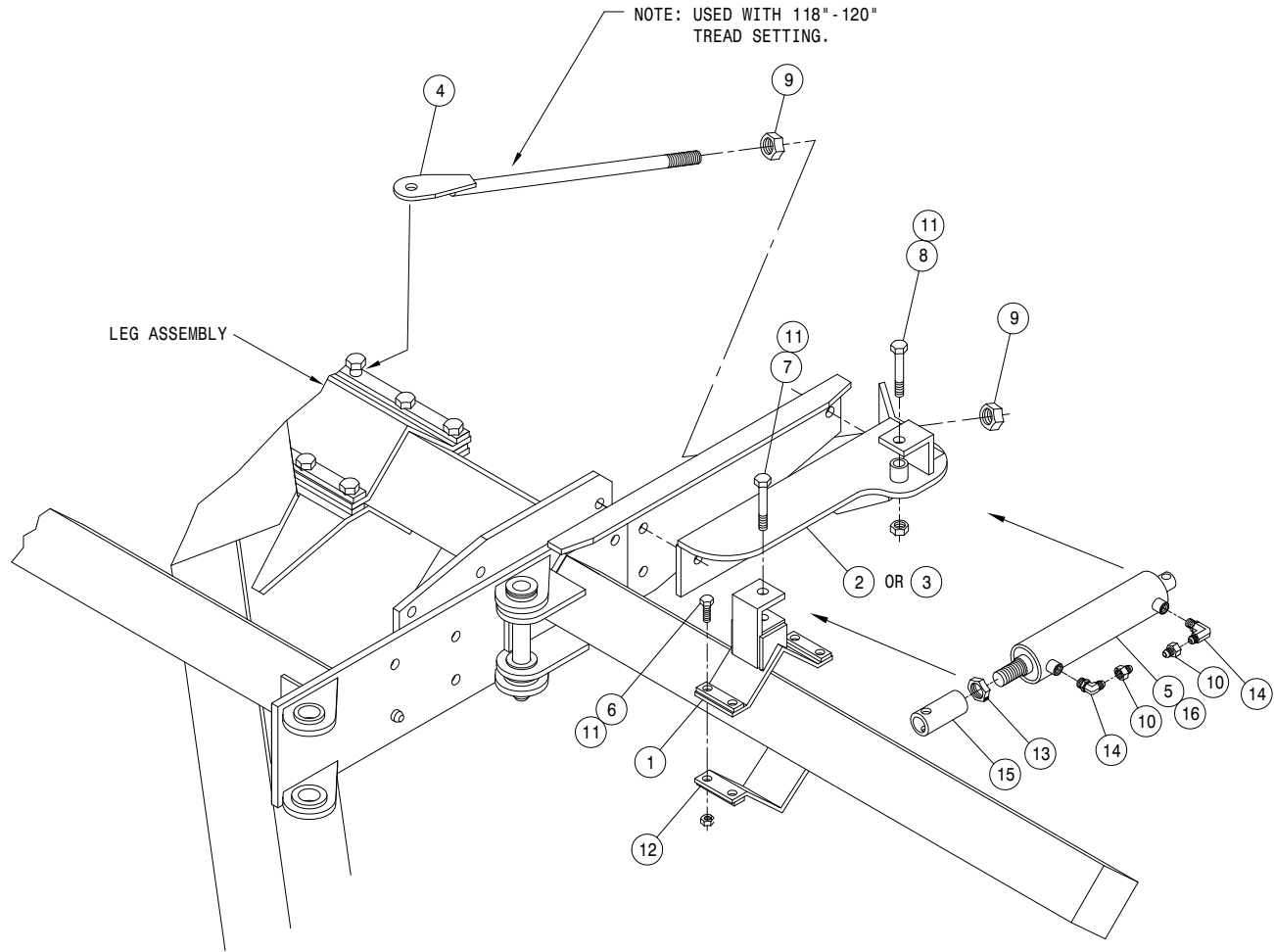

NOTE: USED WITH 118" - 120" TREAD SETTING.

LEG ASSEMBLY

OUTRIGGER HYDRAULIC FOLD ASSEMBLY

DET.	QTY	PART NO.	DESCRIPTION
1	2	438772	OUTRGR CYL MT WLD, 204/SP 08
2	1	438735	RH FOLD CYL MT WLD, 204/SP
3	1	438736	LH FOLD CYL MT WLD, 204/SP
4	2	438745	FOLD CYL MT SUPP ROD WLD204/SP
5	2	621520	BOOM HINGE FOLD CYL ASSY
6	8	900337	5/8UNC X 2 3/4 HEX BOLT
7	2	900338	5/8UNC X 3" HEX BOLT
8	2	900341	5/8UNC X 3 3/4 HEX BOLT
9	4	910012	3/4UNC HEX NUT
10	4	618731	9/16JIC .025 ORIFICE ADPTR
11	12	914010	5/8UNC HEX STOVER NUT
12	2	438777	CYL MT KEEPER WLD, 204/SP 08
13	2	472322	7/8-14 UNF HEX JAM NUT
14	4	618119	9/16MJIC-90-9/16MOR LBO
15	2	620653	FOLD CYL ADJ SLEEVE 97
16	2	621521	REPAIR KIT, HYD CYL 621520

QUANTITY LISTED IS FOR ONE MACHINE.

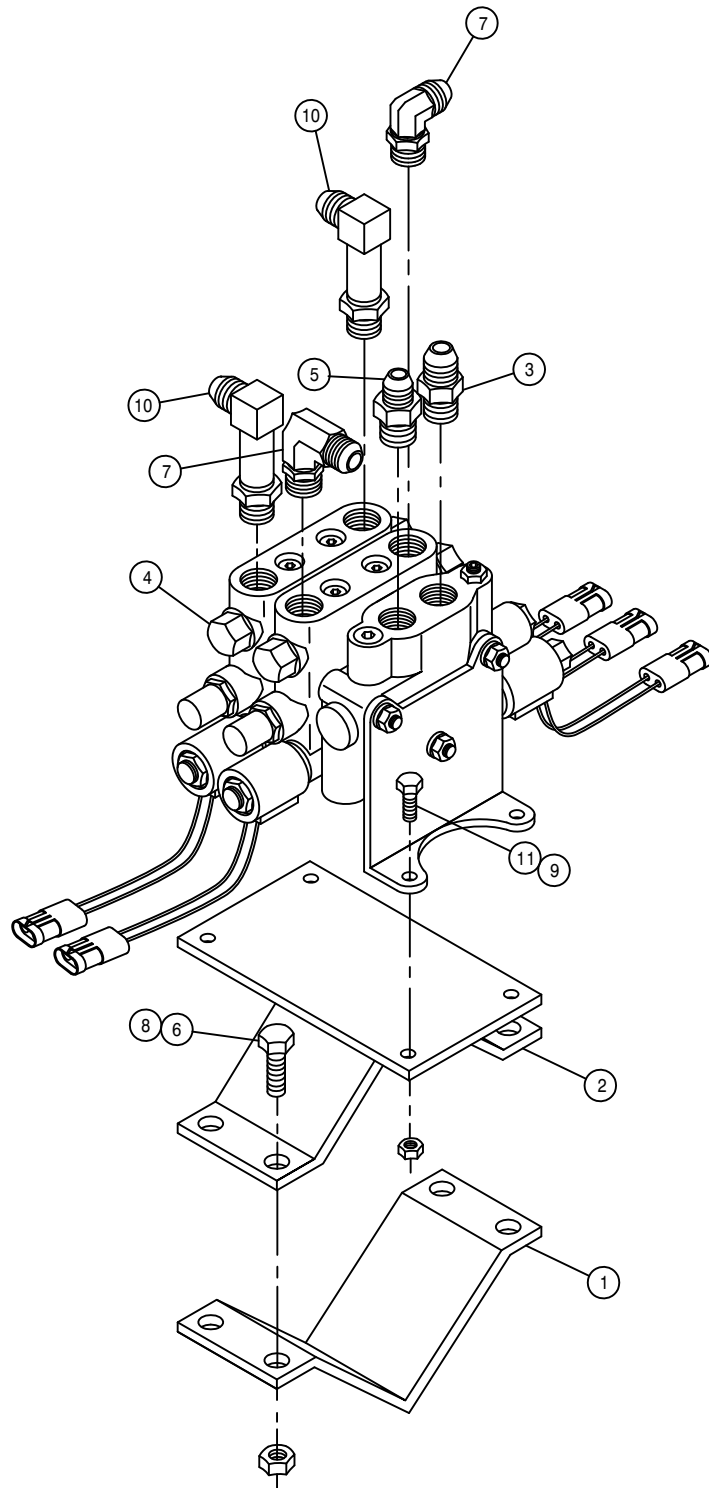

OUTRIGGER FOLD VALVE ASSEMBLY

DET.	QTY	PART NO.	DESCRIPTION
1	1	438324	75IN OUTGR BRACE CLAMP
2	1	438724	OUTGR FOLD VLV MT WLD2100/STS
3	1	618327	3/4MJIC-7/8MOR ADPTR
4	1	606090	BRAND HYD VALVE, 2-SECT SER 36
5	1	618310	9/16MJIC-7/8MOR ADPTR
6	4	900265	1/2UNC X 1 1/2 HEX BOLT
7	2	618115	9/16MJIC-90-3/4MOR LBO
8	4	914008	1/2UNC HEX STOVER NUT
9	4	914002	5/16UNC HEX STOVER NUT
10	2	618709	9/16MJIC-90-3/4MOR EX LG LBO
11	4	900065	5/16UNC X 1" HEX BOLT

REAR WEIGHT BRACKET ASSEMBLY

DET. QTY PART NO. DESCRIPTION

1	1	341980	RH REAR TOOL BAR MT WLD 2XX
2	1	341981	LH REAR TOOL BAR MT WLD 2XX
3	1	438575	RH WEIGHT MT BRKT WLD 96
4	1	438576	LH WEIGHT MT BRKT WLD 96
5	1	438660	IH 173MAG WEIGHT ADPT PLT WLD
6	1	438581	WEIGHT MT PLATE WLD,JD 204 96
7	4	900277	1/2UNC X 5 1/2 HEX BOLT
8	4	900281	1/2UNC X 7 1/2 HEX BOLT
9	4	900335	5/8UNC X 2" HEX BOLT
10	8	914008	1/2UNC HEX STOVER NUT
11	5	914010	5/8UNC HEX STOVER NUT
12	8	920004	1/2 SAE FLAT WASHER
13	1	438580	WEIGHT MT PLATE 96
14	1	438648	CASE IH WEIGHT LOCK BOLT WLD
15	1	438650	CASE IH 173MAG LOCK BOLT PLATE

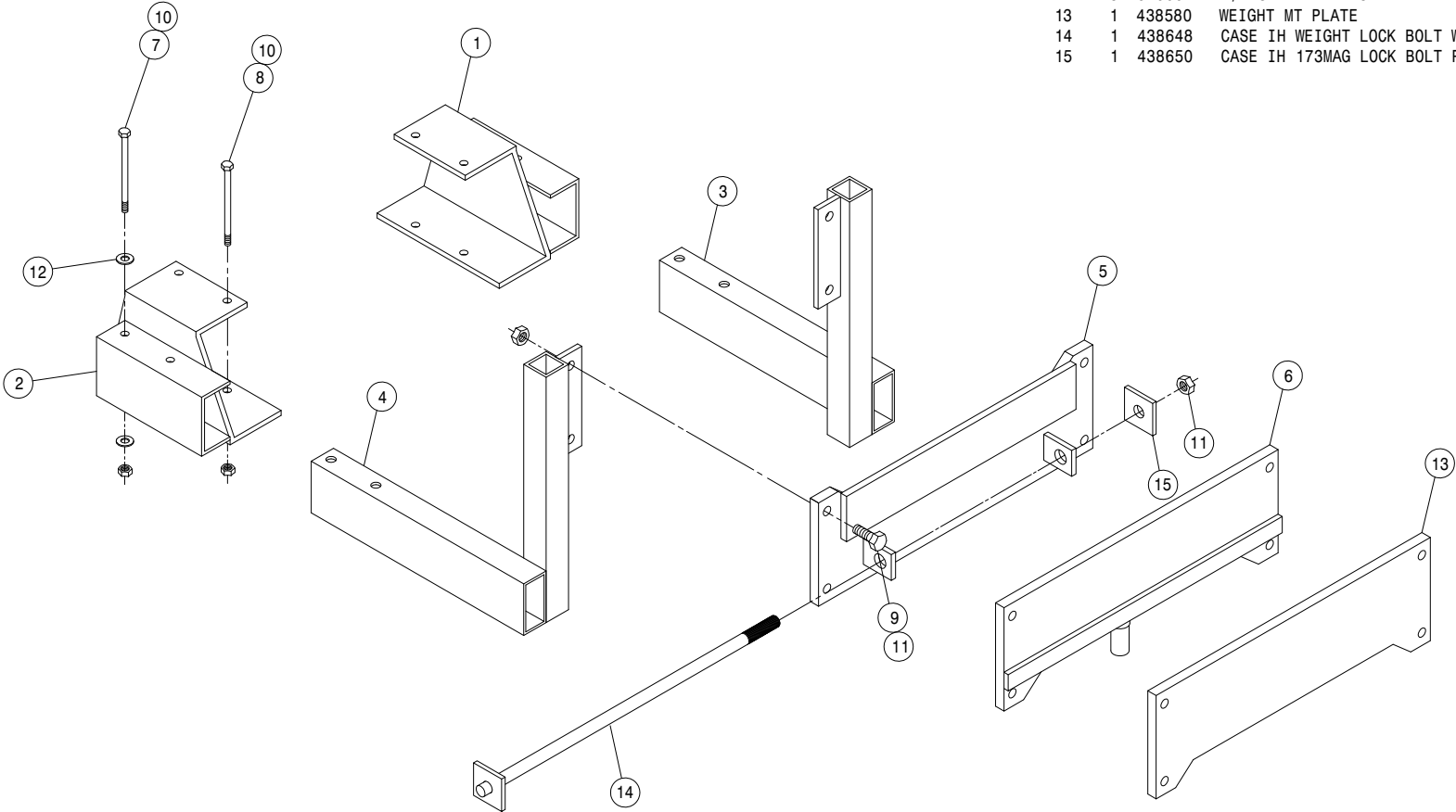

This Page Intentionally Blank

NOTICE

The following page contains decals for the model 204 SP.

These decals can be obtained from Hagie Mfg. Co. and should be used whenever your machine is repainted or when the decals become worn, weathered, or faded.

Special attention should be paid to decals involving personal safety. They have been attached for your protection.

KEEP THEM IN PLACE.

**Contact: Hagie Manufacturing Co.
Box 273
Clarion, Iowa 50525**

204SP DECALS

QTY.	PART NO.	DESCRIPTION	LOCATION
1	650154	PATENTS, HAGIE UPFRONT DECAL	ON LEFT FRONT OPERATOR STATION
2	650211	HYDRAULIC FILTER DECAL	2-1 EA END OF HYDRAULIC TANK
1	650256	COOLING SYSTEM DECAL	NEAR RADIATOR CAP
2	650258	DANGER, CUTTING BLADES	2-ON EACH CUTTER HEAD
4	650259	CAUTION MOVING PARTS DECAL	2 - EACH TASSEL DEFLECTOR 1 - ON EACH QUAD PULLER 1 - ON EACH TIRE PULLER
1	650269	CONSOLE COVER DECAL	ON CONSOLE COVER
1	650270	CANTRAK FUNCTION DECAL	ON CANTRAK
1	650271	FUSE BLOCK DECAL	ON SIDE OF OPERATOR STATION
1	650303	CUTTER ROTATION DECAL	ON FRONT OPERATOR STATION
1	650308	LEFT L-CTR R-CTR RIGHT DECAL	DEPTH COMMAND SWITCH BOX
1	650320	EMERGENCY EXIT DECAL	RIGHT SIDE CAB GALSS
1	650338	DEPTH CMD 6-LIFT DECAL	DEPTH COMMAND SWITCH BOX
1	650389	WARNING, HYD OIL INJ DECAL	ON FRONT OPERATOR STATION
1	650347	NOTICE-R134A CHARGE DECAL	NEXT TO A/C COMPRESSOR
4	650364	AIR BAG WARNING DECAL	1-ON EACH AIR BAG BY AIR STEM
1	650367	AIR FILTER INSTRUCTION DECAL	ON ENGINE AIR FILTER END CAP
1	650379	ENGAGE HYD MOTOR DECAL	ON CONSOLE COVER
1	650383	HAGIE LOGO DECAL	ON MANUAL HOLDER
1	650384	MANUALS DECAL	ON MANUAL HOLDER
1	650831	EMERGENCY STOP DECAL	ON CONSOLE SHEET METAL
1	650847	NO PASSENGER DECAL	ON FRONT OPERATOR STATION
2	650848	SLIP OR FALL DECAL	NEXT TO STEP ON EACH LEG RAIL
2	650849	ENGINE FUEL DECAL	NEAR EACH FUEL TANK NECK
2	650851	SHIELDS DECAL	ON SIDE OF TOP ENGINE COVER
3	650931	HAGIE DECAL 1 3/4 X 4	1 - ON EACH TASSEL DEFLECTOR 1 - ON EACH QUAD PULLER
2	650954	DIESEL DECAL	NEAR EACH FUEL TANK NECK
1	650982	ELECTRICAL DECAL	RIGHT HAND SIDE OF OIL TANK
4	650985	WHEEL BOLT TORQUE DECAL	ON EACH WHEEL RIM
1	KDCC001	DECAL SET, 204SP 05	ON EACH ENGINE HOOD

NOTE: NOTCH IN SWITCH

293168 - 2L DEPTH CMD NEG WIRE ASSY

TO GROUND

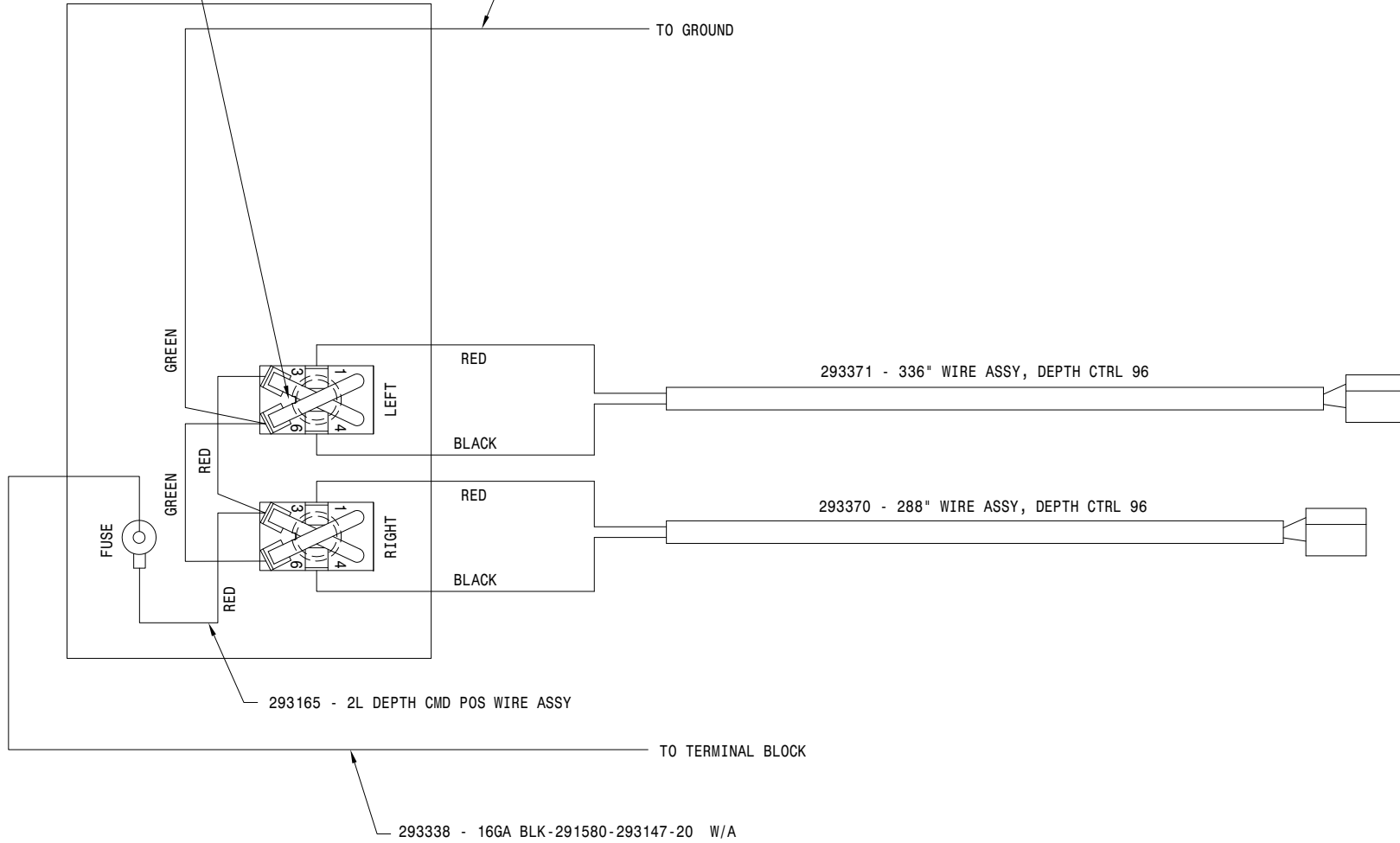

84

DET	REQ	DESCRIPTION
HAGIE HAGIE MANUFACTURING COMPANY CLARION, IOWA 50525		
REMOVE ALL SHARP CORNERS & BURRS		
TOLERANCE UNLESS OTHERWISE SPECIFIED		
FRACTION ±1/32	DECIMALS X.XX ±.03 X.XXX ±.005	ANGLES ±1°
DESCRIPTION		
WIRE DIAG, 2-LIFT DEPTH CMD 94		
DRAWN BY T. MARKER	SCALE NONE (1)	APPROVED BY
CHECKED BY	APPROVED BY	
DATE 03-29-94	DRAWING NUMBER 498450	
SHEET OF		

498084

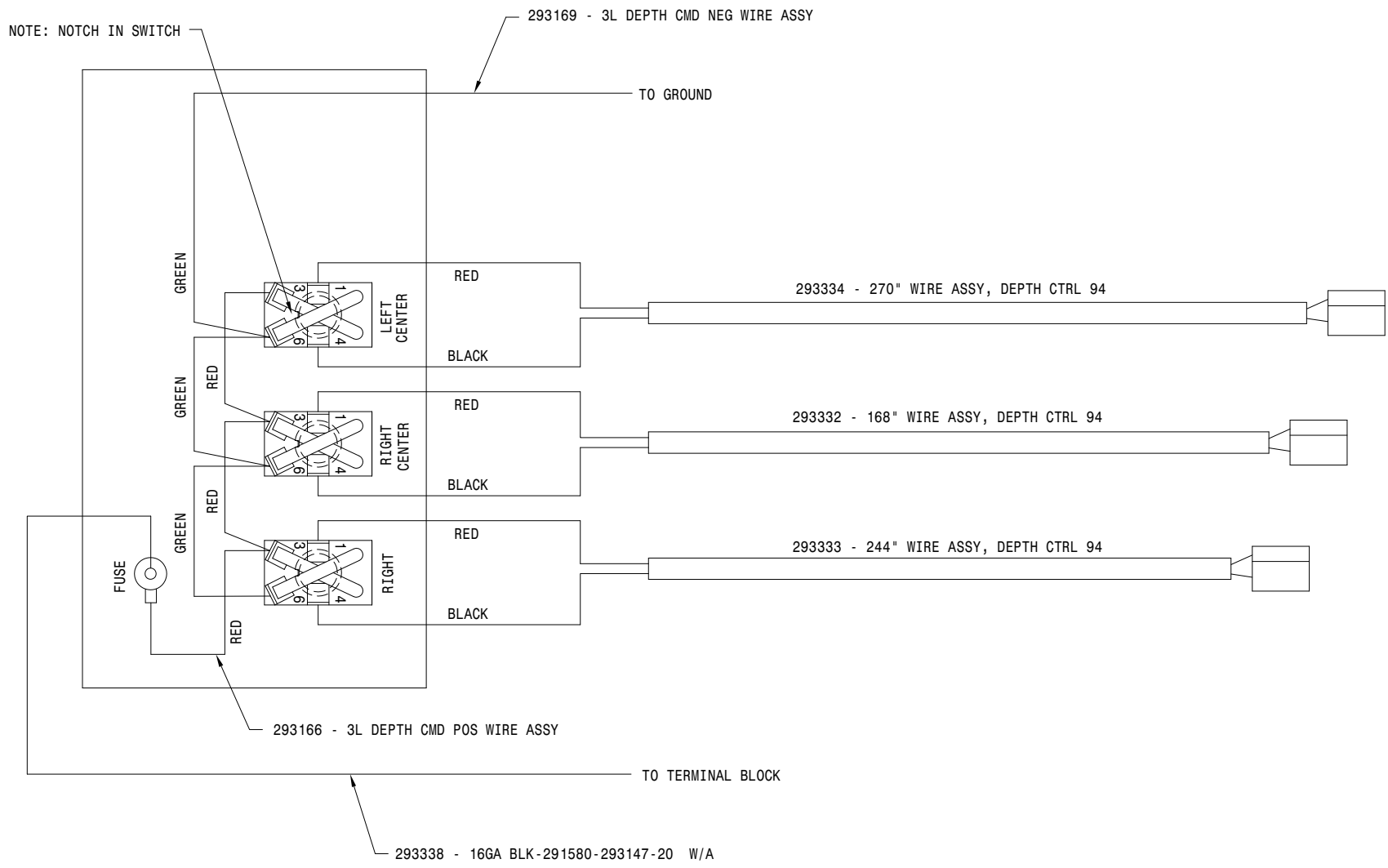

DET	REQ	DESCRIPTION
HAGIE HAGIE MANUFACTURING COMPANY CLARION, IOWA 50525		
REMOVE ALL SHARP CORNERS & BURRS		
TOLERANCE UNLESS OTHERWISE SPECIFIED		
FRACTION ±1/32	DECIMALS X.XX ±.03 X.XXX ±.005	ANGLES ±1°
DESCRIPTION		
WIRE DIAG, 3-LIFT DEPTH CMD 94		
DRAWN BY T. MARKER	SCALE NONE	
CHECKED BY	APPROVED BY	
DATE 03-29-94	DRAWING NUMBER 498451	
SHEET	OF	

NOTE: NOTCH IN SWITCH

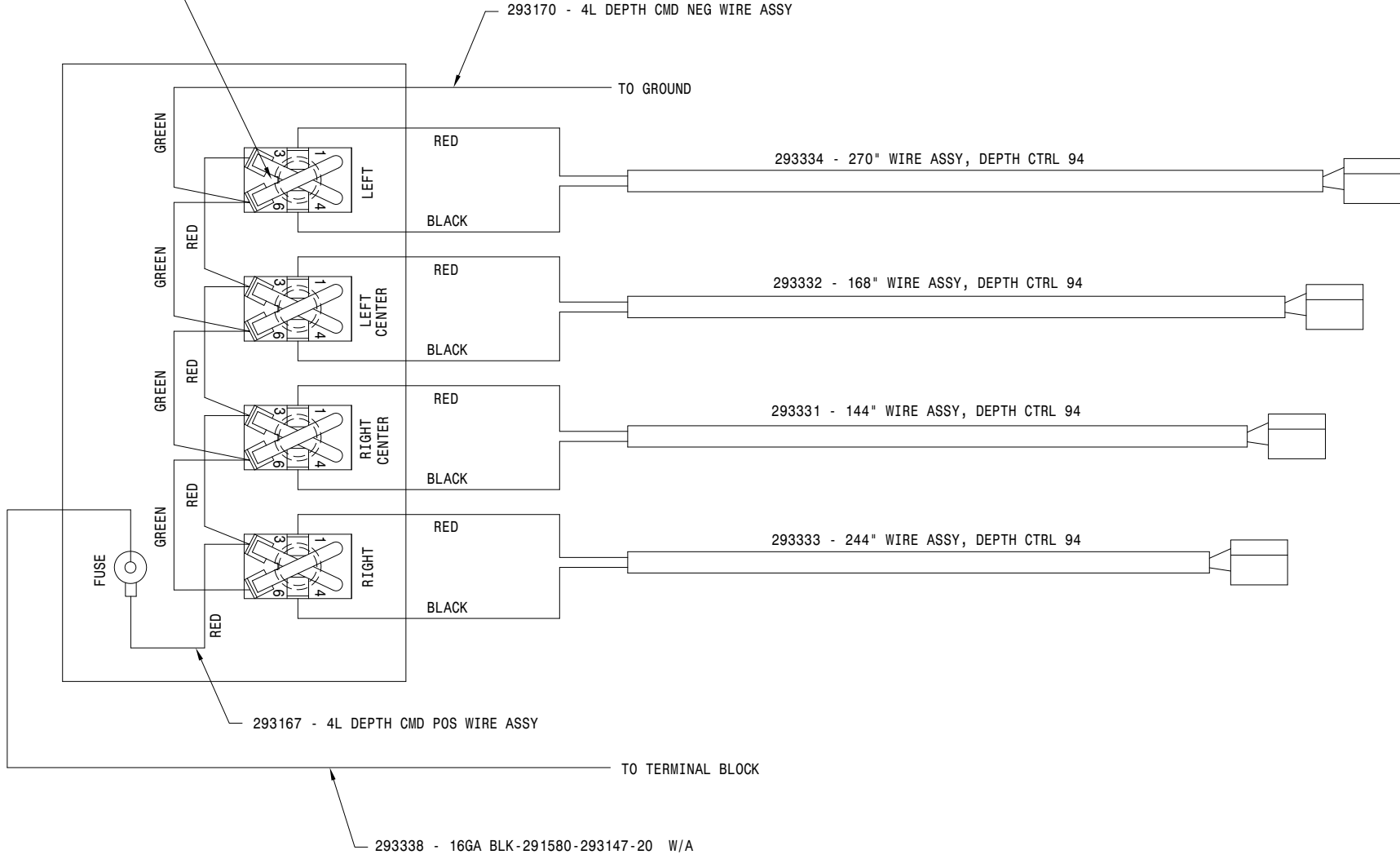

DET	REQ	DESCRIPTION
HAGIE HAGIE MANUFACTURING COMPANY CLARION, IOWA 50525		
REMOVE ALL SHARP CORNERS & BURRS		
TOLERANCE UNLESS OTHERWISE SPECIFIED		
FRACTION ±1/32	DECIMALS X.XX ±.03 X.XXX ±.005	ANGLES ±1°
DESCRIPTION		
WIRE DIAG, 4-LIFT DEPTH CMD 94		
DRAWN BY T. MARKER	SCALE NONE	APPROVED BY
CHECKED BY	APPROVED BY	
DATE 03-29-94	DRAWING NUMBER 498452	
SHEET	OF	

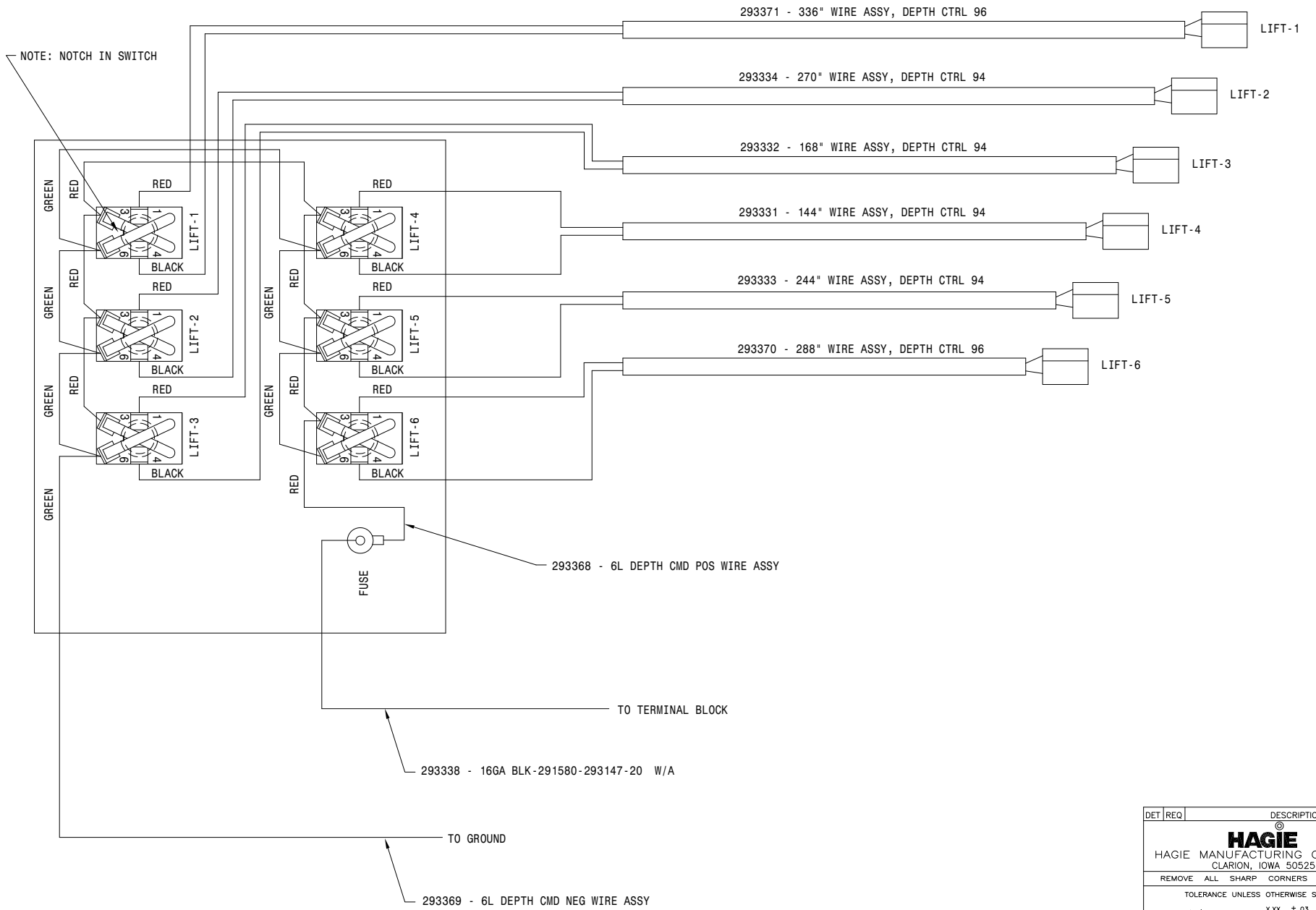

DET	REQ	DESCRIPTION
HAGIE HAGIE MANUFACTURING COMPANY CLARION, IOWA 50525		
REMOVE ALL SHARP CORNERS & BURRS		
TOLERANCE UNLESS OTHERWISE SPECIFIED		
FRACTION ±1/32	DECIMALS X.XX ±.03 X.XXX ±.005	ANGLES ±1°
DESCRIPTION WIRE DIAG, 6-LIFT DEPTH CMD 96		
DRAWN BY T. MARKER	SCALE NONE (1)	APPROVED BY
CHECKED BY	DRAWING NUMBER 498479	
DATE 02-26-96	SHEET OF	

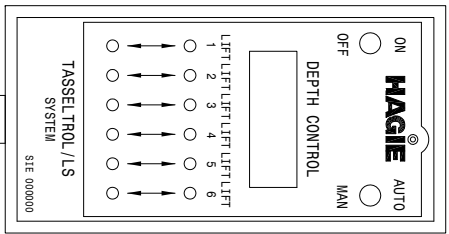

785077 - FASSE EZ-3 CONTROL HANDLE, 204

293377 - POWER CABLE, 6L L/S WIRE ASSEMBLY

293718 - LIFT VALVE WIRE HARNESS 08

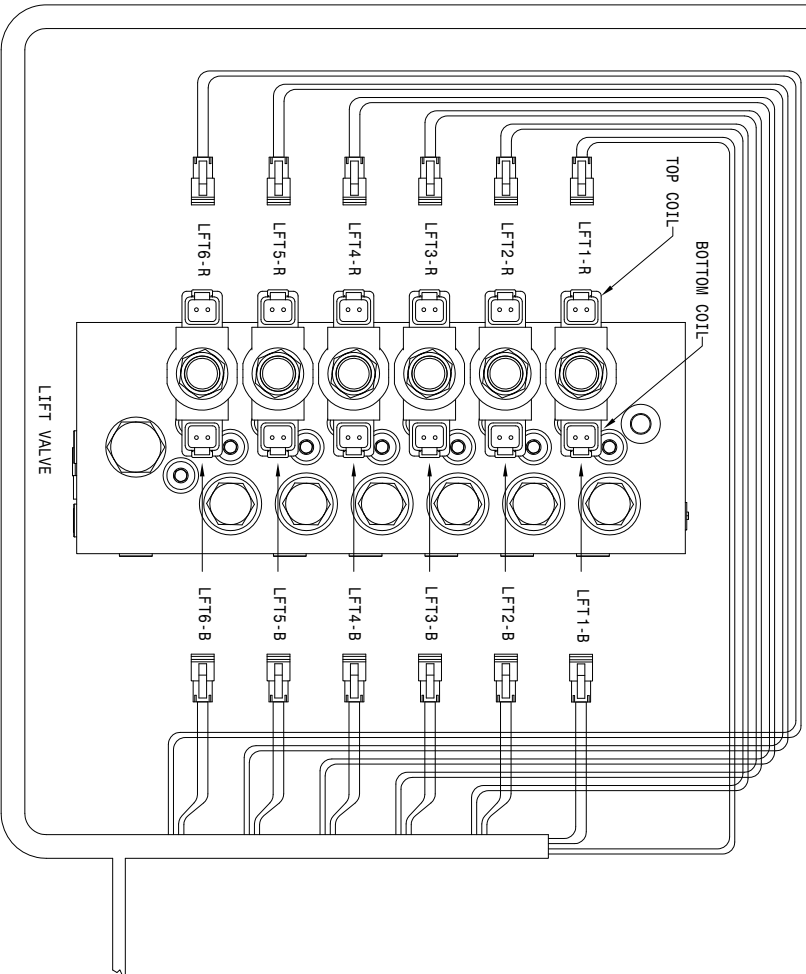

293378 - REMOTE DISPLAY CABLE 6L L/S

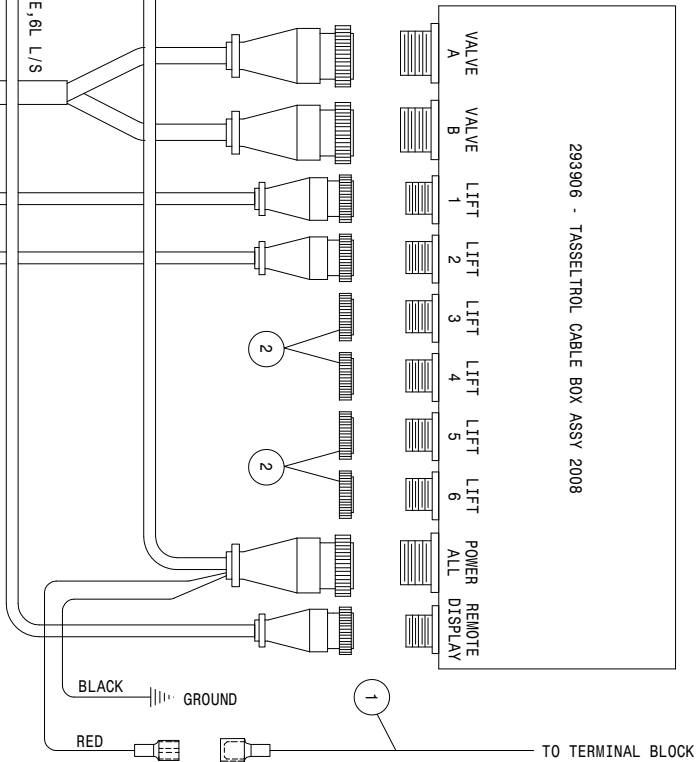

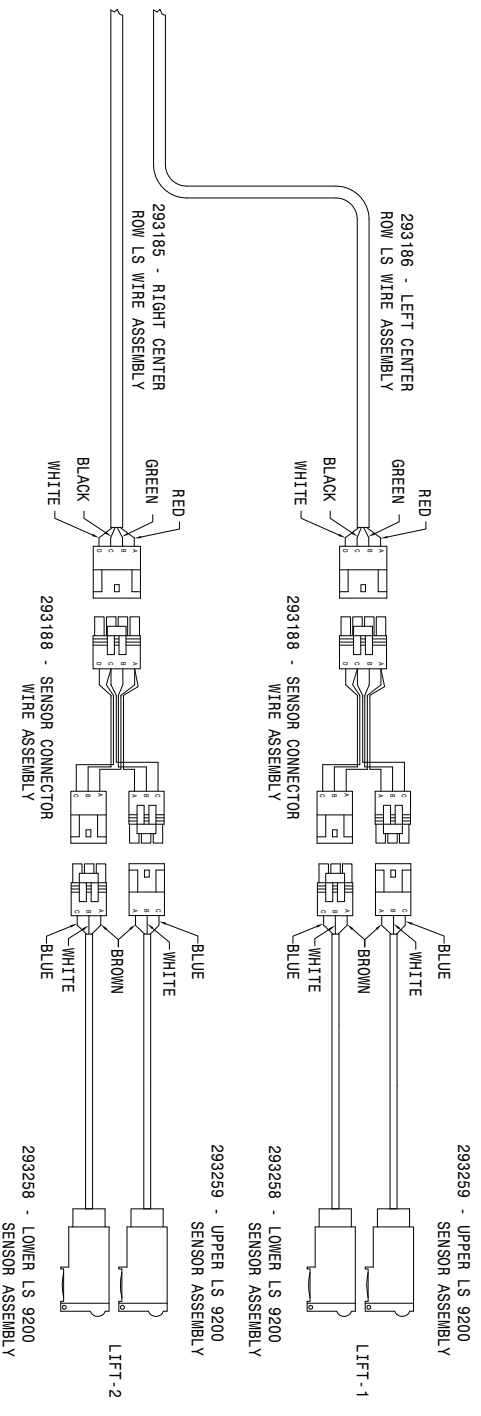

REFER TO DRAWING
499215 SHEET 1 OF 3

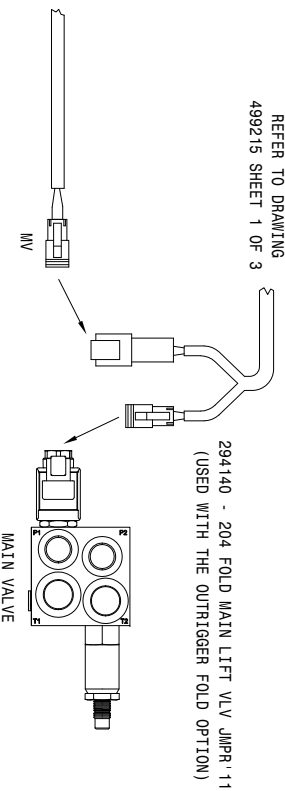

294140 - 204 FOLD MAIN LIFT VLV JIMPR-11
(USED WITH THE OUTRIGGER FOLD OPTION)

2	4	293406	AMP CONVER SIZE 11
1	1	293329	1624 BLK-291357-29163-44
DET REQ		DESCRIPTION	
HAGIE MANUFACTURING COMPANY CLARION, IOWA 50525			
REMOVE ALL SHARP CORNERS & BURRS			
TOLERANCE UNLESS OTHERWISE SPECIFIED			
FRACTION 1/32		DECIMAL .XXX ±.03 ANGLES ±.1°	
DRAWN BY T. MARKER SCALE HALF			
CHECKED BY		APPROVED BY	
DATE 08-15-07	DRAWING NUMBER 498996		
SHEET 08			

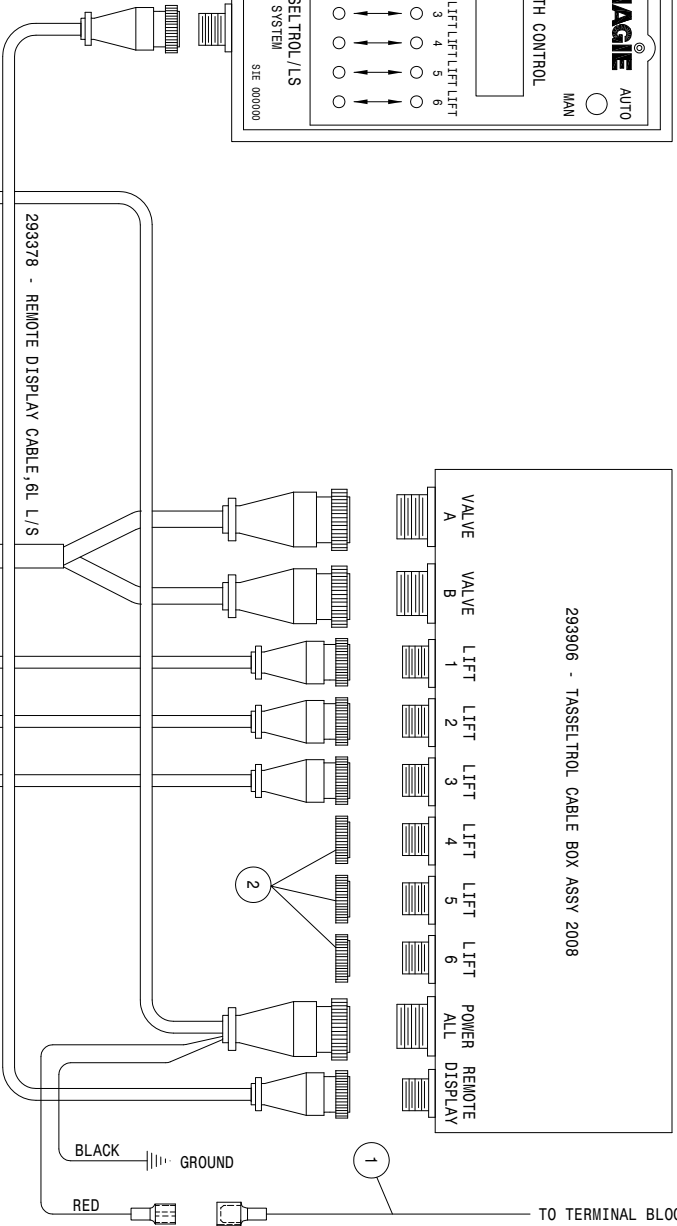
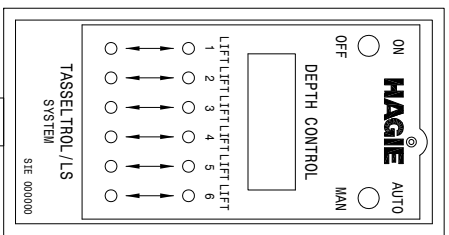

785077 - FASSE EZ-3 CONTROL HANDLE, 204

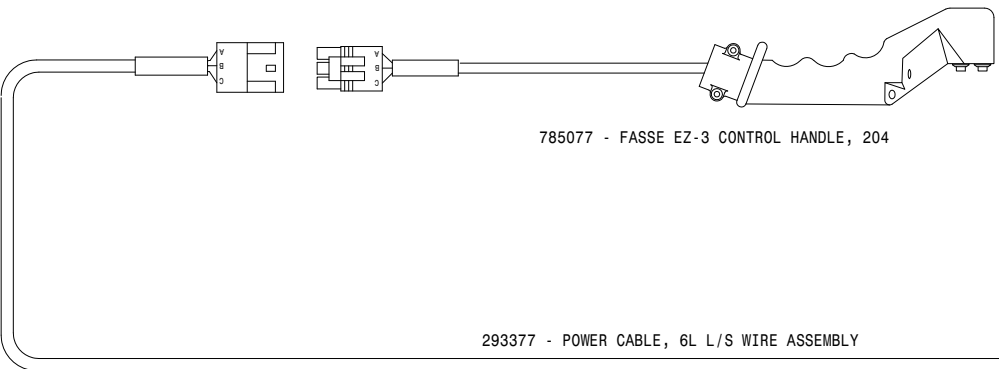

293718 - LIFT VALVE WIRE HARNESS 08

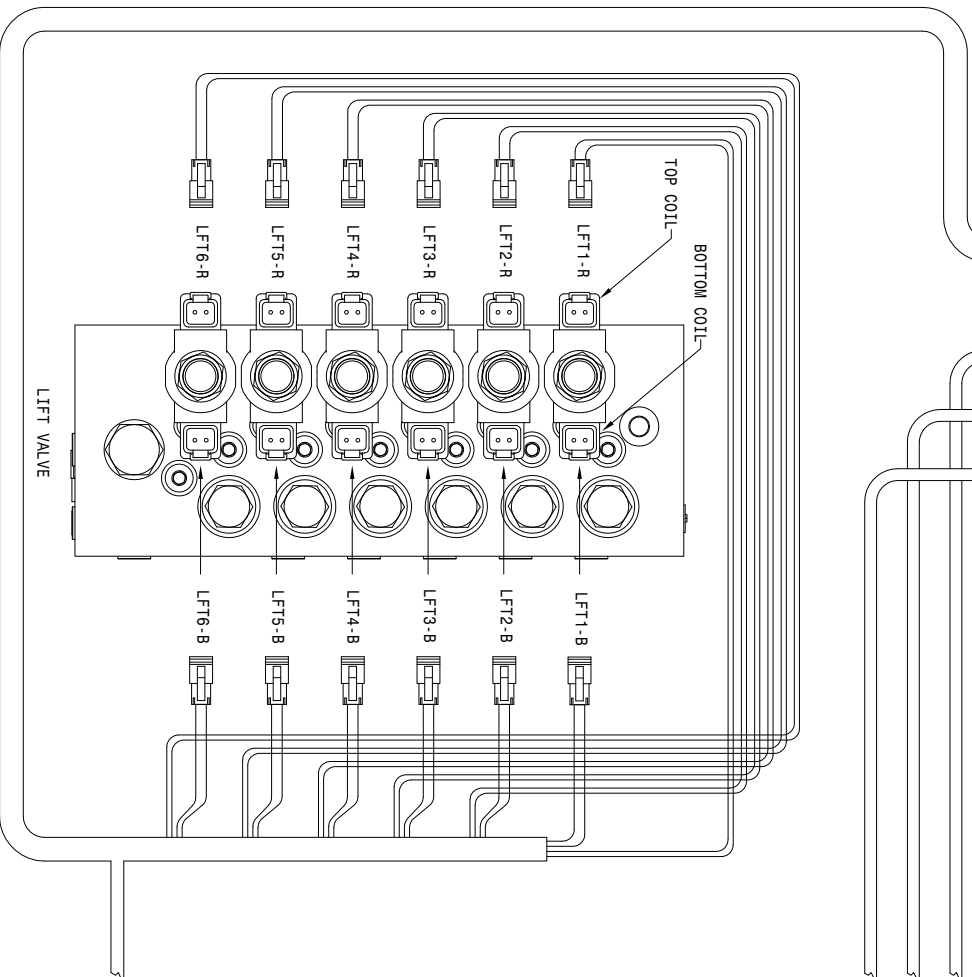

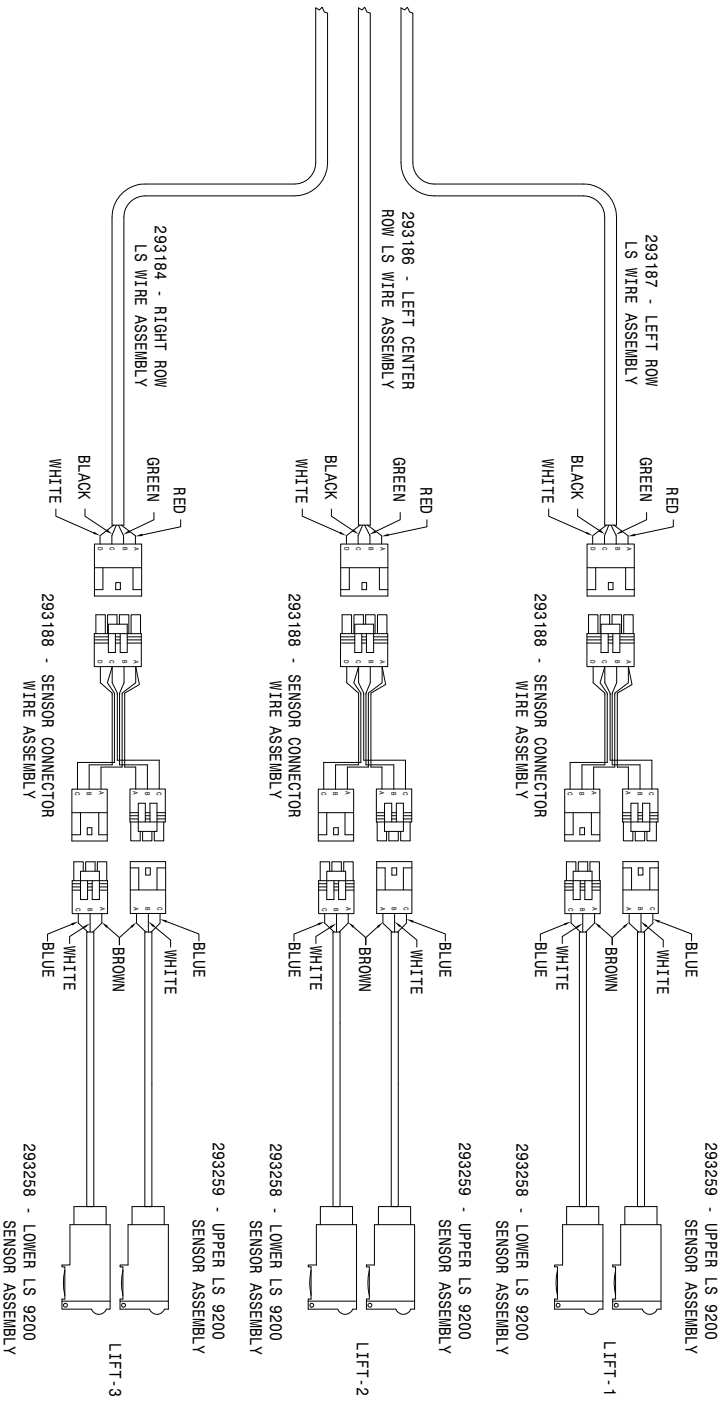

REFER TO DRAWING
499215 SHEET 1 OF 3

294140 - 204 FOLD MAIN LIFT VLV JIMPR-11
(USED WITH THE OUTRIGGER FOLD OPTION)

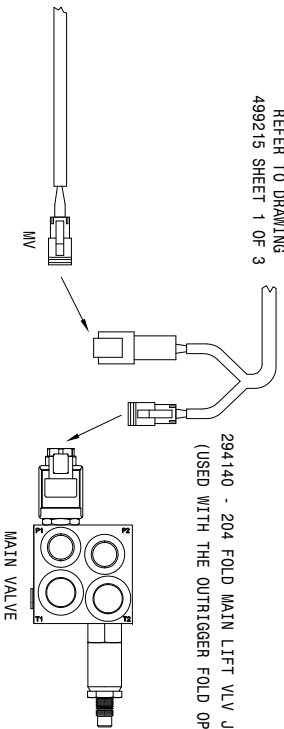

2	3	293046	AMP COVER SIZE 11
1	1	293239	1604 BLK-293157-293163-44
DEF: RECQ			
DESCRIPTION			
HAGIE MANUFACTURING COMPANY			
CLARION, IOWA, 50525			
REMOVE ALL SHARP CORNERS & BURRS			
TOLERANCE UNLESS OTHERWISE SPECIFIED			
FRACION 1/16	DECIMALS .XXX ± .01	ANGLES 1/4°	
DRAWN BY SCALE			
T.L. MARKERS			
CHECKED BY			
DATE 04-22-08			
DRAWING NUMBER			
SHEET 08			

499004

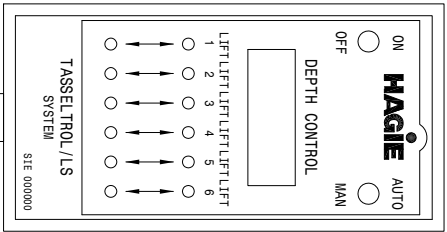

785077 - FASSE EZ-3 CONTROL HANDLE, 204

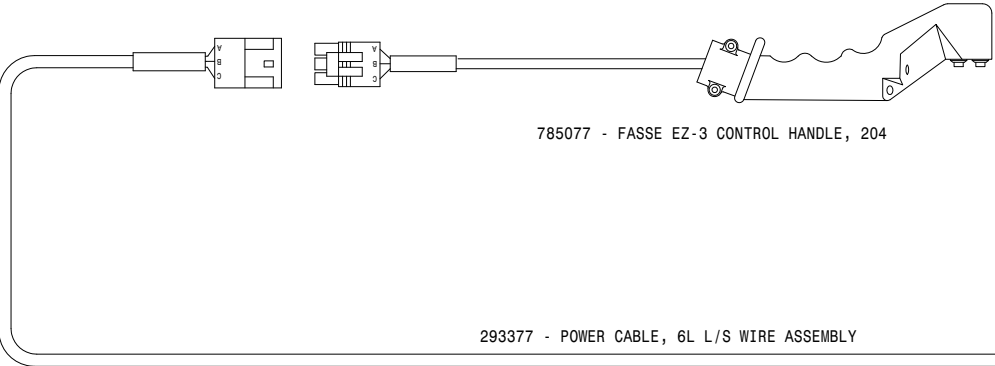

293377 - POWER CABLE, 6L L/S WIRE ASSEMBLY

293718 - LIFT VALVE WIRE HARNESS 08

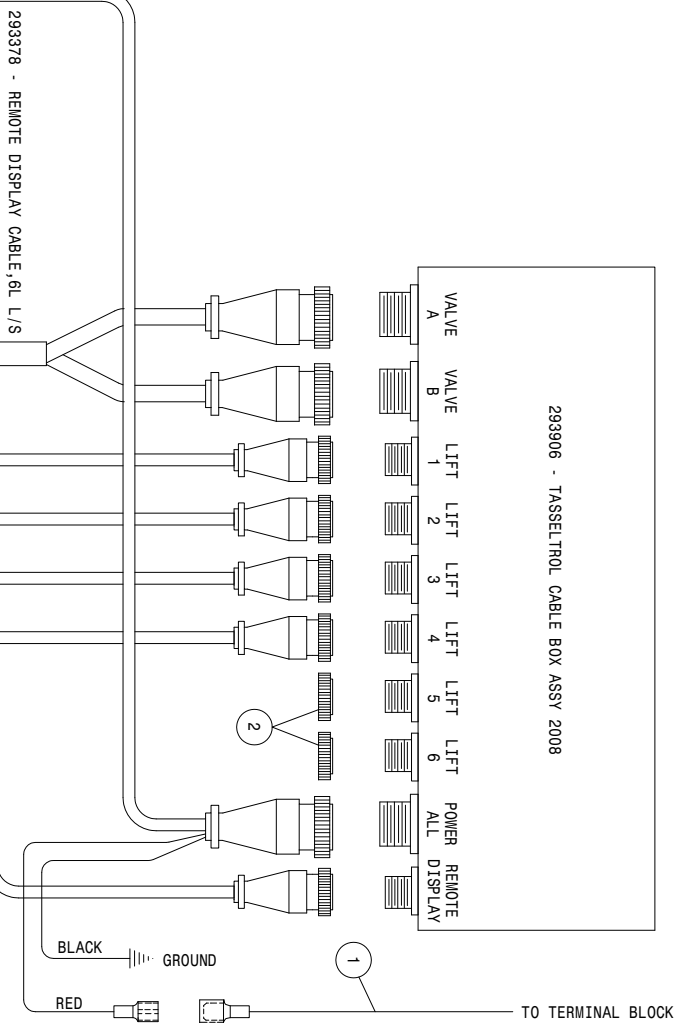
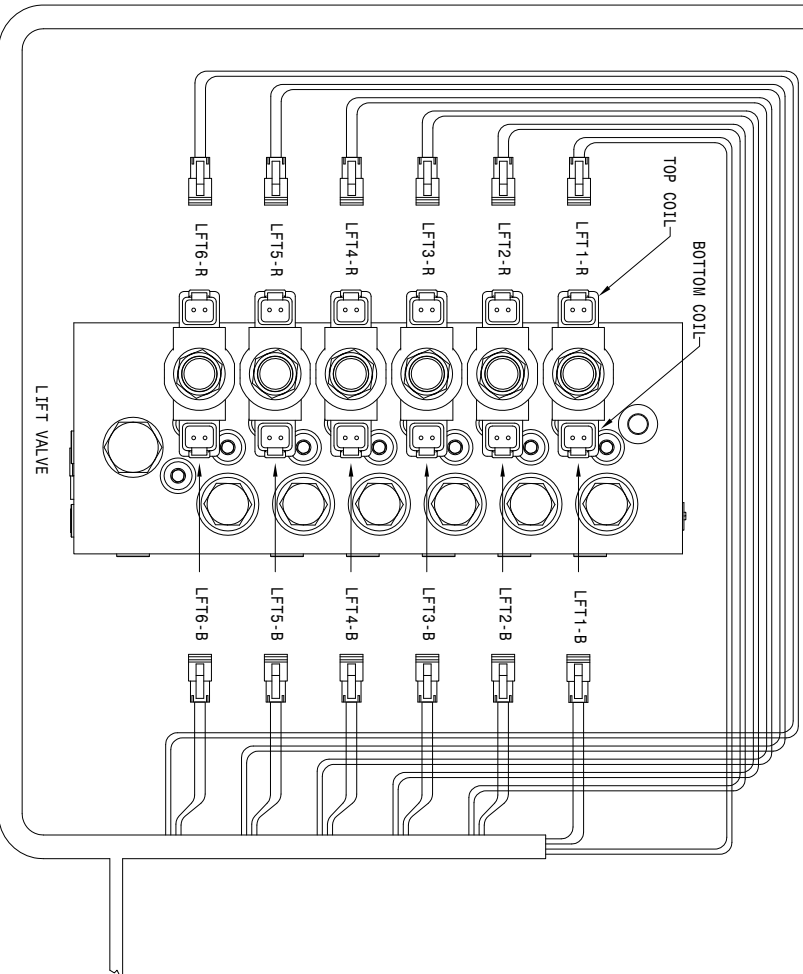

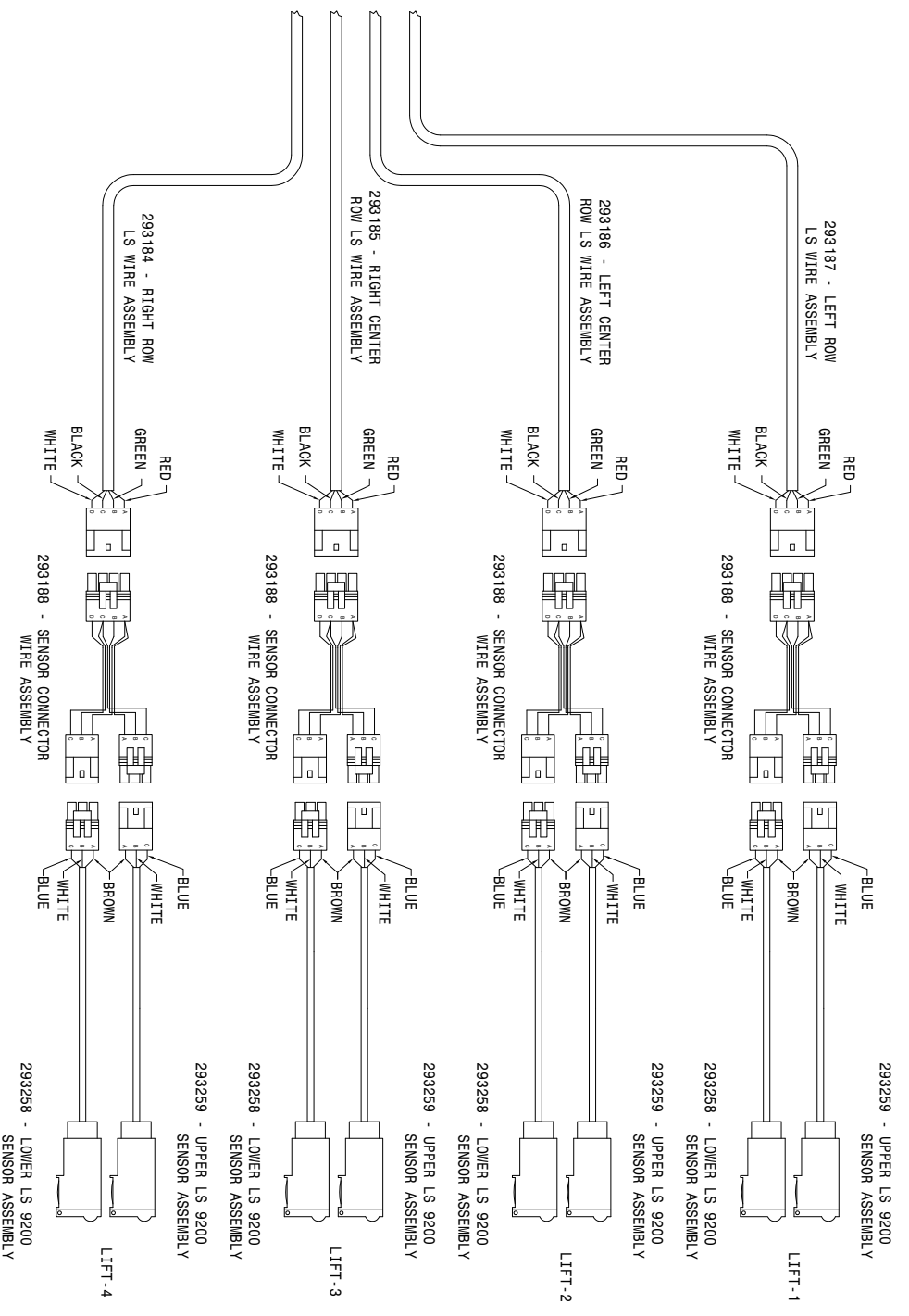

REFER TO DRAWING
499215 SHEET 1 OF 3

294140 - 204 FOLD MAIN LIFT VLV JMPR 11
(USED WITH THE OUTRIGGER FOLD OPTION)

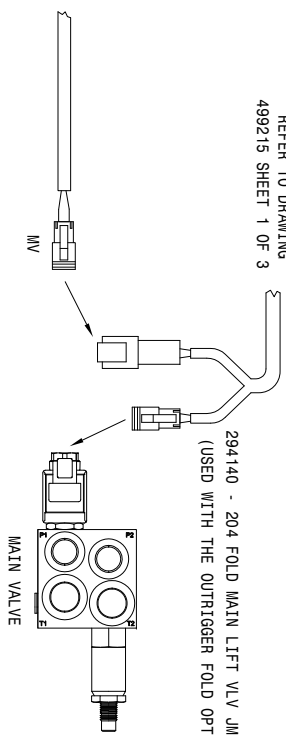

2	2	293046	AMP CONVS SIZE 11
1	1	293029	1604 BLK-291557-29163-44
HAGIE HAGIE MANUFACTURING COMPANY CLARION, IOWA 50525 REMOVE ALL SHARP CORNERS & BURRS TOLERANCE UNLESS OTHERWISE SPECIFIED FINISH 1/16" ± .0015 DECIMALS XXX ± .01 ANGLES ± 1°			
REVISION 4- LIFT LS SYS WIRE DIAG, 204, 08			
DRAWN BY		SCALE	
T. MARKER		HALF	
CHECKED BY		APPROVED BY	
DATE 04-22-08		DRAWING NUMBER	
SHEET 08		499005	

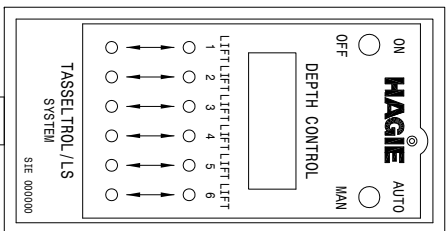

785077 - FASSE EZ-3 CONTROL HANDLE, 204

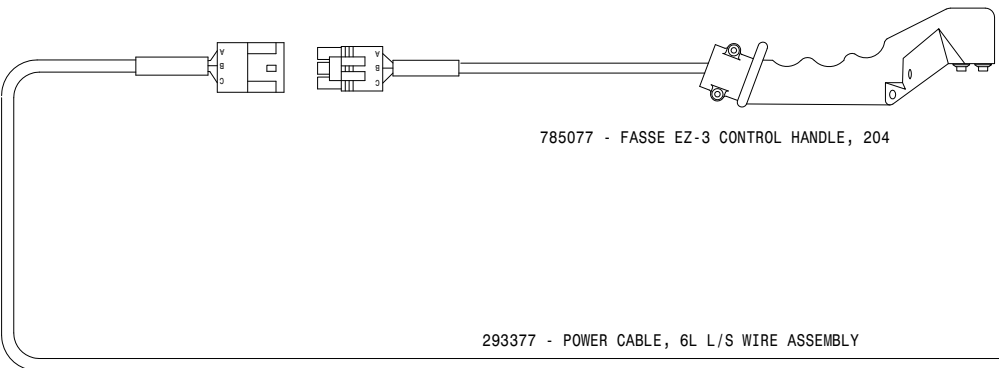

293718 - LIFT VALVE WIRE HARNESS 08

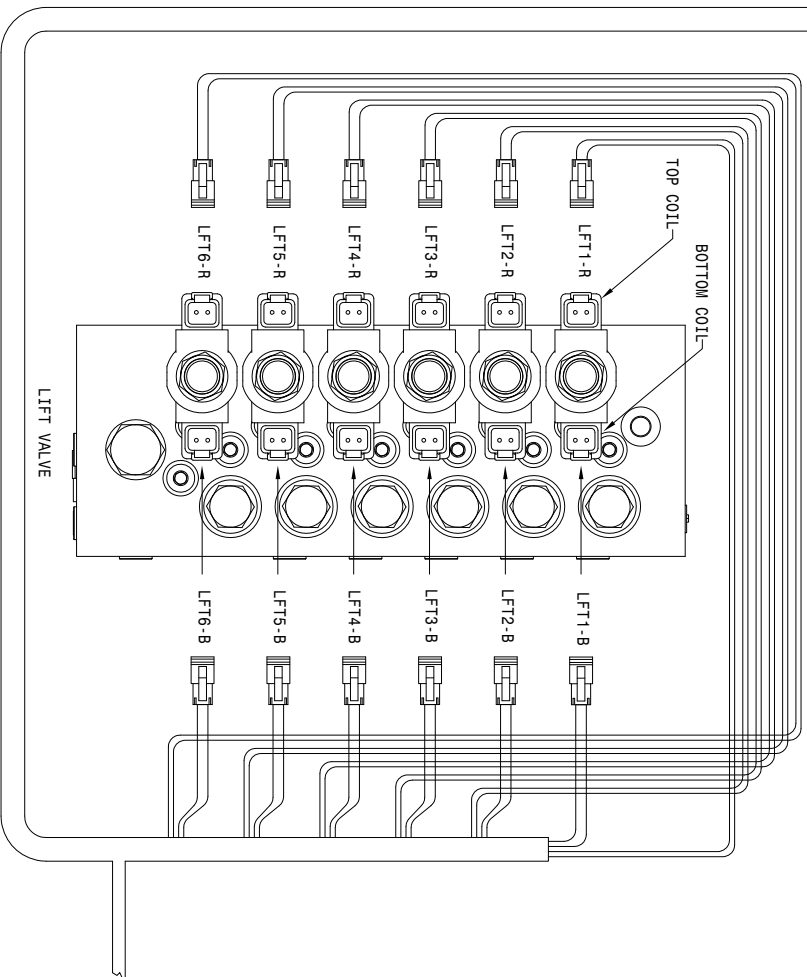

293378 - REMOTE DISPLAY CABLE, 6L L/S

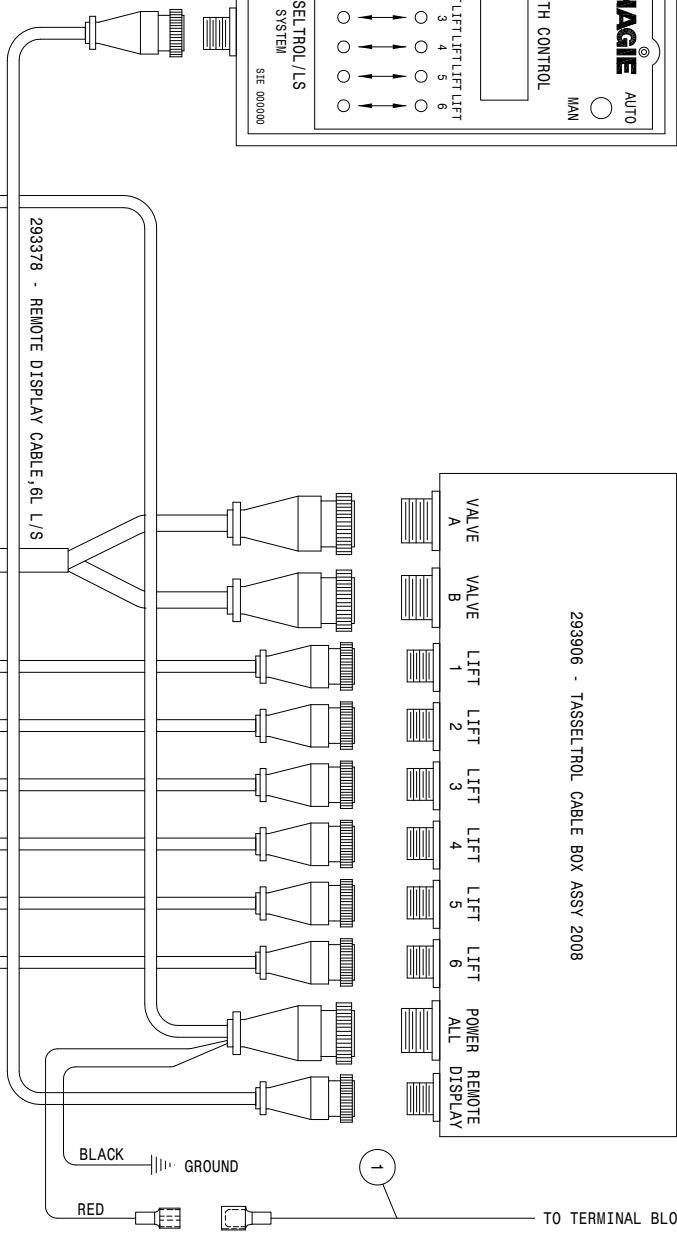

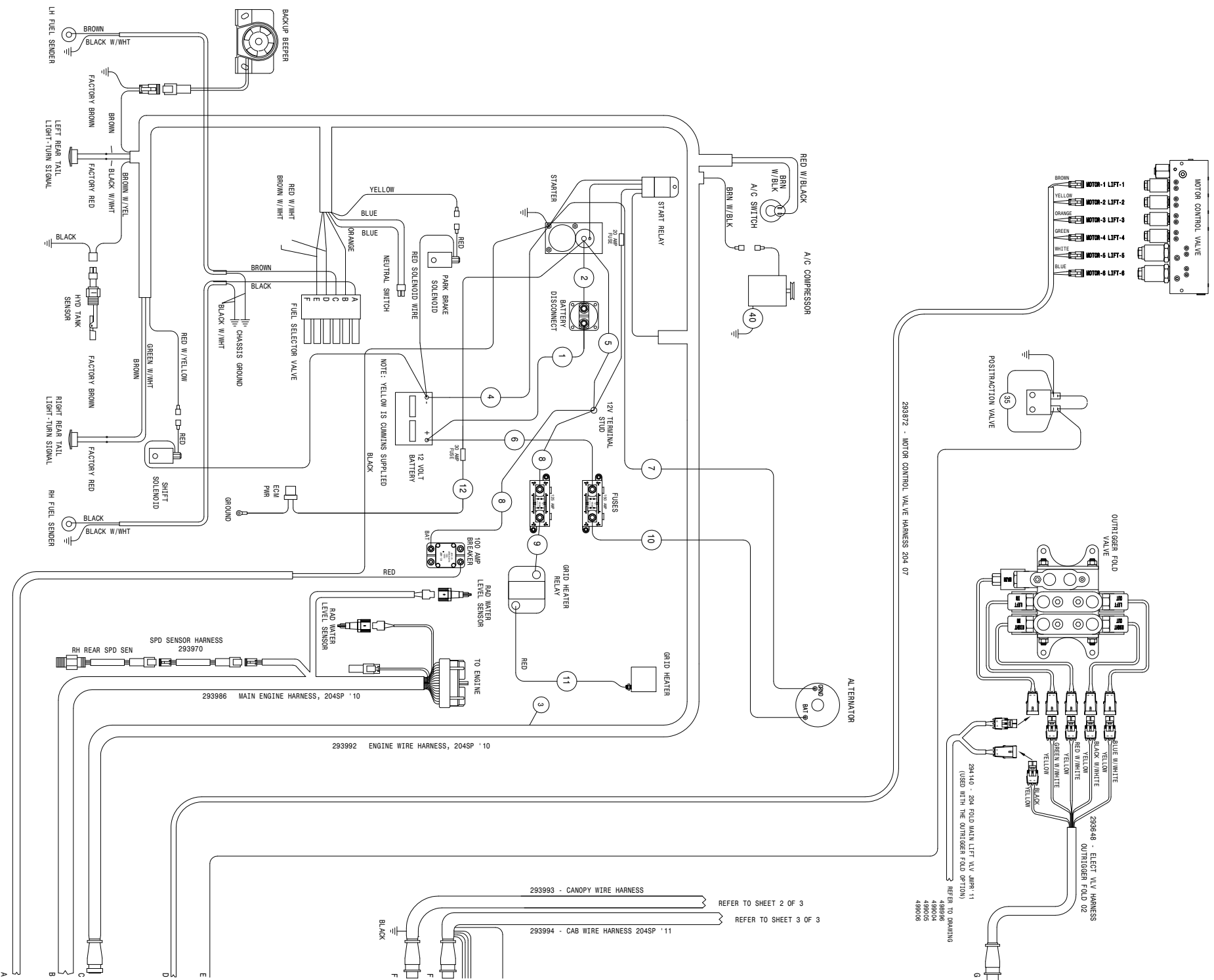

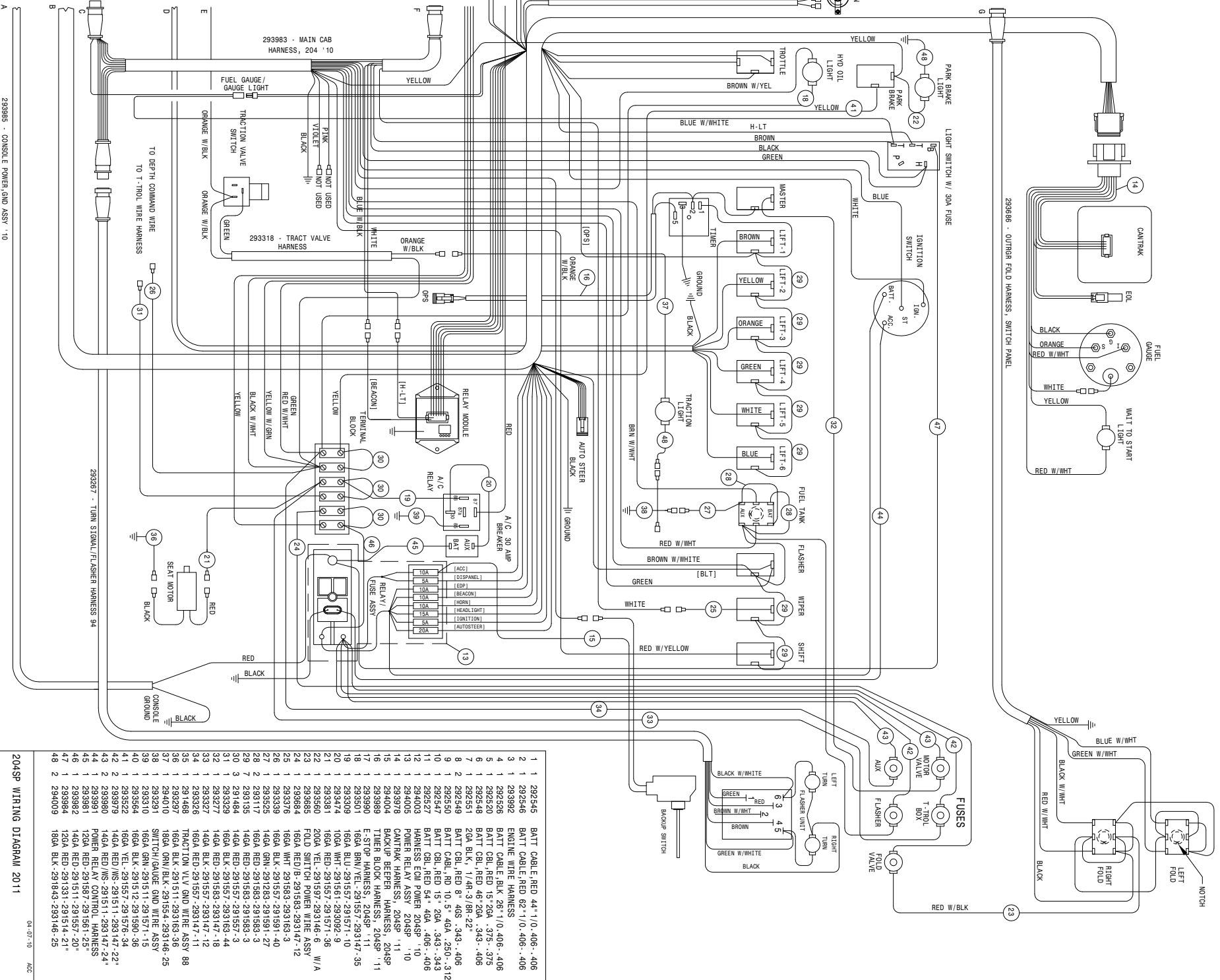

1	292545	BATT CABLE, RED 14" 1/0-406 -406
2	292546	BATT CABLE, RED 62" 1/0-406 -406
3	293982	ENGINE WIRE HARNESS
4	292526	BATT CABLE, BLK 26" 1/0-406 -406
5	292520	BATT CBL, RED 15" 2GA, 375-375
6	292548	BATT CBL, RED 46" 2GA, 343-406
7	292551	2GA BLK, 1/4R-3/8R-22"
8	292549	BATT CBL, RED 8" 4GS, 343-406
9	292549	BATT CBL, RD 10.5" 4GA, 250-312
10	292547	BATT CBL, RED 15" 2GA, 343-343
11	292547	BATT CBL, RED 54" 4GA, 406-406
12	294003	HARNESS, EOL POWER 204SP '10
13	294005	POWER RELAY ASSY 204SP '10
14	293978	CANTANK HARNESS, 204SP '11
15	294004	TRUCK BEERER HARNESS, 204SP '11
16	293989	TIENE BLOCK HARNESS, 204SP '11
17	293990	E-STOP HARNESS, 204SP '11
18	293501	16GA BRN/YEL-291557-293147-35
19	293309	16GA BLU-291557-291571-10
20	293474	16GA WHT-291561-293022-9
21	293381	16GA WHT-291597-293146-6 W/A
22	293860	20GA YEL-291597-293147-12
23	293860	16GA WHT-291597-293147-12
24	293864	16GA WHT-291593-293147-30
25	293864	16GA BLK-291593-293147-30
26	293864	16GA WHT-291593-293147-30
27	293864	16GA WHT-291593-293147-30
28	293117	16GA, RED-291583-291583-3
29	293135	16GA, RED-291583-291583-3
30	291484	16GA, RED-291557-291557-3
31	293329	16GA, RED-291557-291557-3
32	293277	16GA, RED-291583-293147-44
33	293327	16GA, BLK-291557-293147-12
34	293326	16GA, RED-291557-293147-11
35	291468	TRACTION VLV GND WIRE ASSY 88
36	293297	16GA BLK-291511-293163-36
37	294010	18GA OHN, BLK-291511-293146-25
38	293291	18GA GRN-291511-291571-15
39	293310	16GA GRN-291511-291571-15
40	293564	16GA, BLK-291512-291590-36
41	293522	16GA, YEL-291557-291576-34
42	293979	14GA, RED, NS-291511-293147-22"
43	293980	14GA, RED, NS-291511-293147-24"
44	293981	POWER RELAY CONTROL HARNESS
45	293981	12GA, RED-291597-291561-25
46	293982	12GA, RED-291511-291597-20"
47	293984	12GA, RED-291531-293146-21"
48	294009	18GA, BLK-291849-293146-25

204SP WIRING DIAGRAM 2011
 SHEET 1 OF 3
 REVISION DATE: 04-02-12
 499215

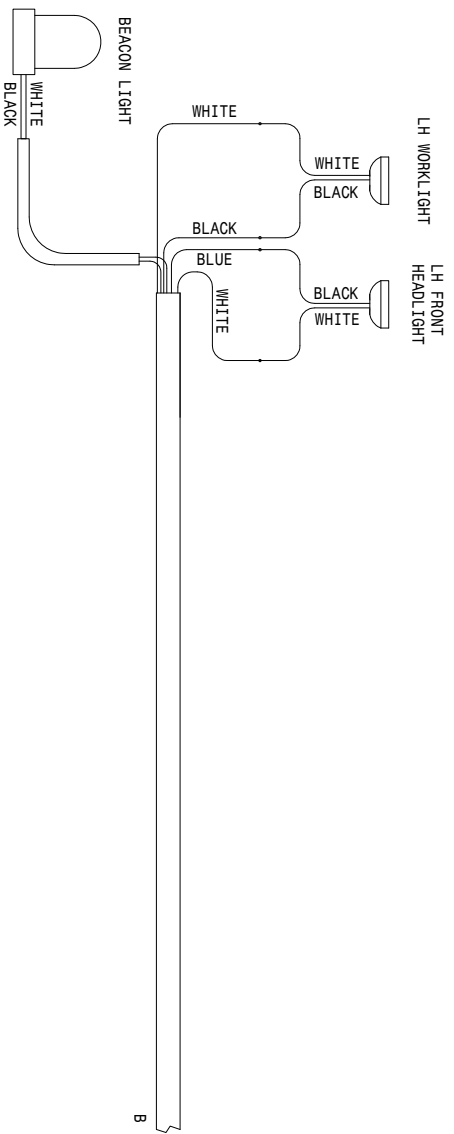
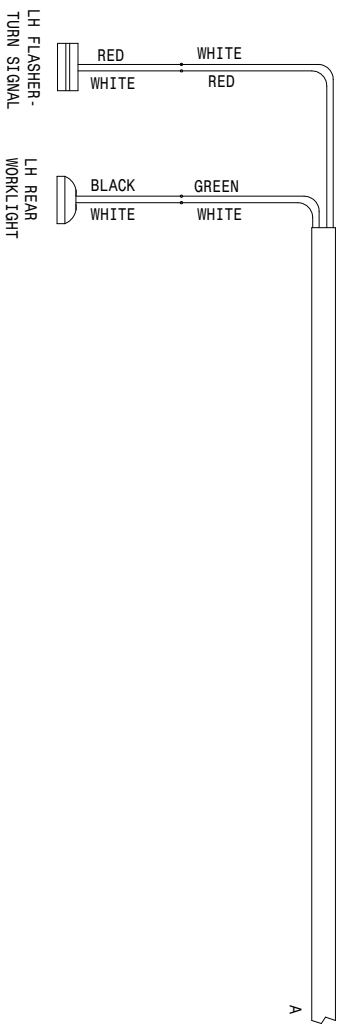

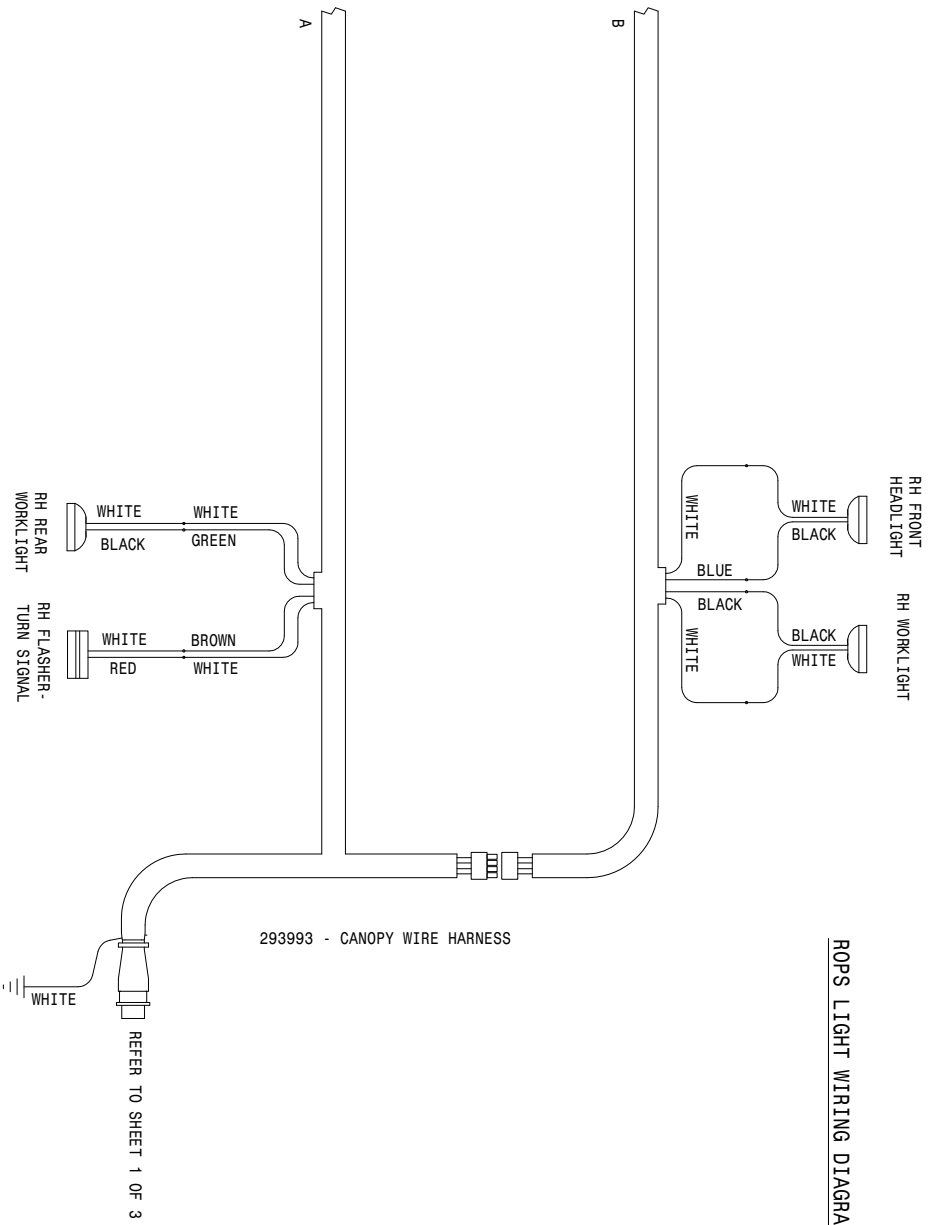

ROPS LIGHT WIRING DIAGRAM

04-07-10 ACC
 204SP WIRING DIAGRAM 2011
 SHEET 2 OF 3
 REVISION DATE: 04-07-10
 499215

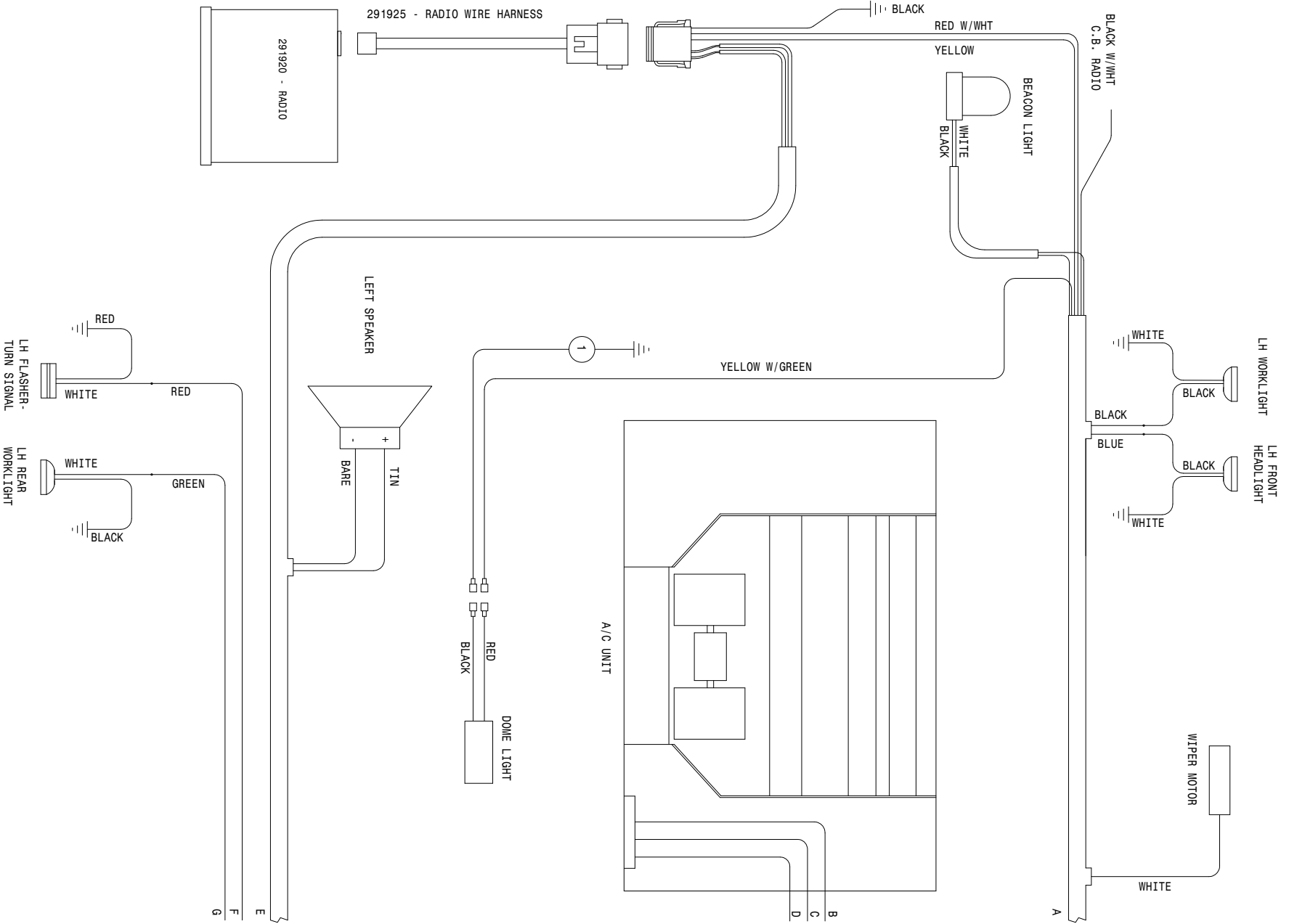

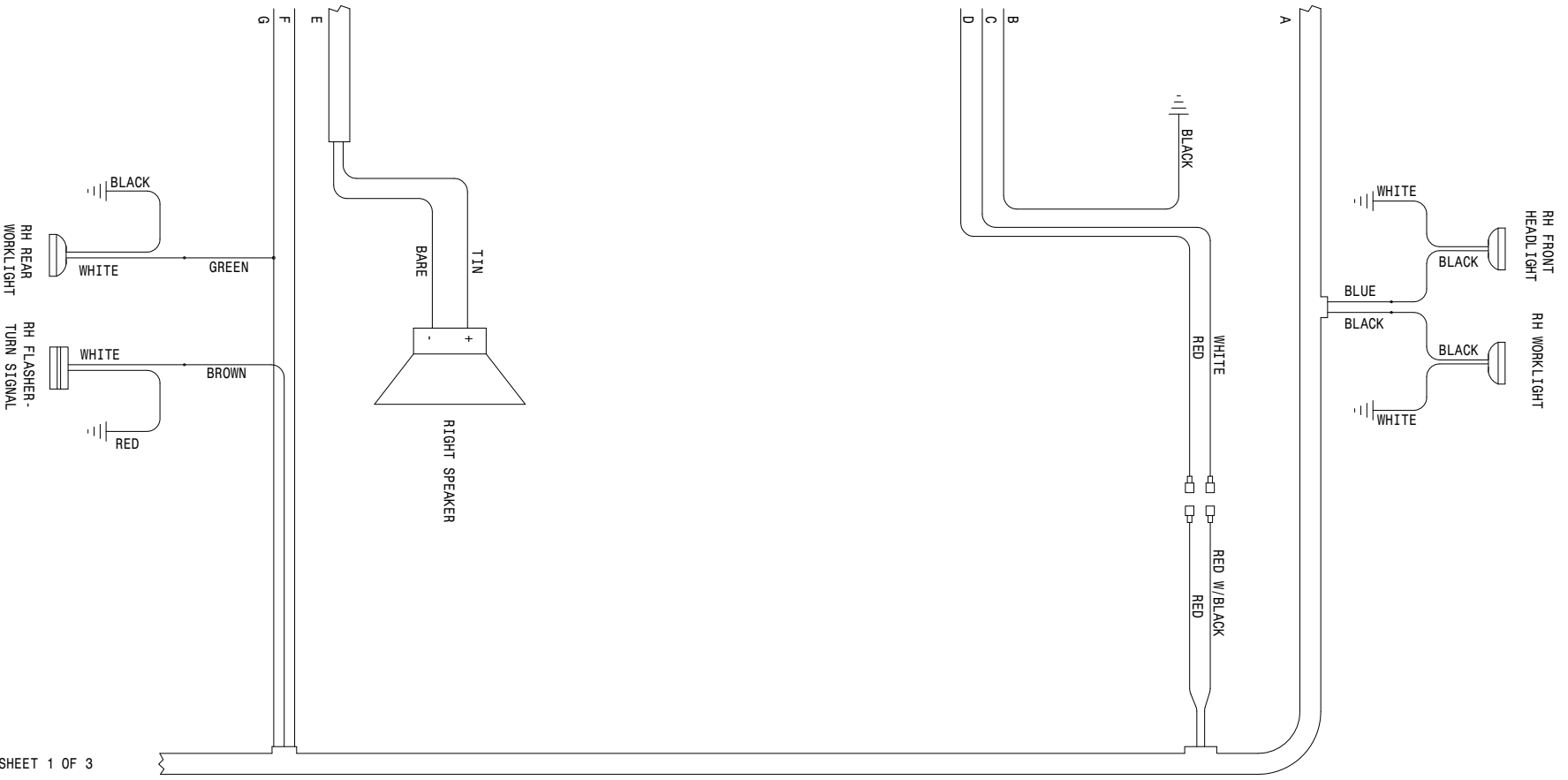

293994 - CAB WIRE HARNESS, 204SP '10

REFER TO SHEET 1 OF 3

1	1	293299	160A	BLK-291511-291571-30
204SP WIRING DIAGRAM '11				
04-07-10 AAC				
SHEET 3 OF 3				
REVISION DATE: 06-02-10				
499215				

*NOTE:
 REFER TO DETAIL 114 TO CHECK PRESSURE LIMIT
 SETTING - 4500 PSI
 REFER TO DETAIL 112 ON TOP TO CHECK CHARGE
 PRESSURE - 380 PSI

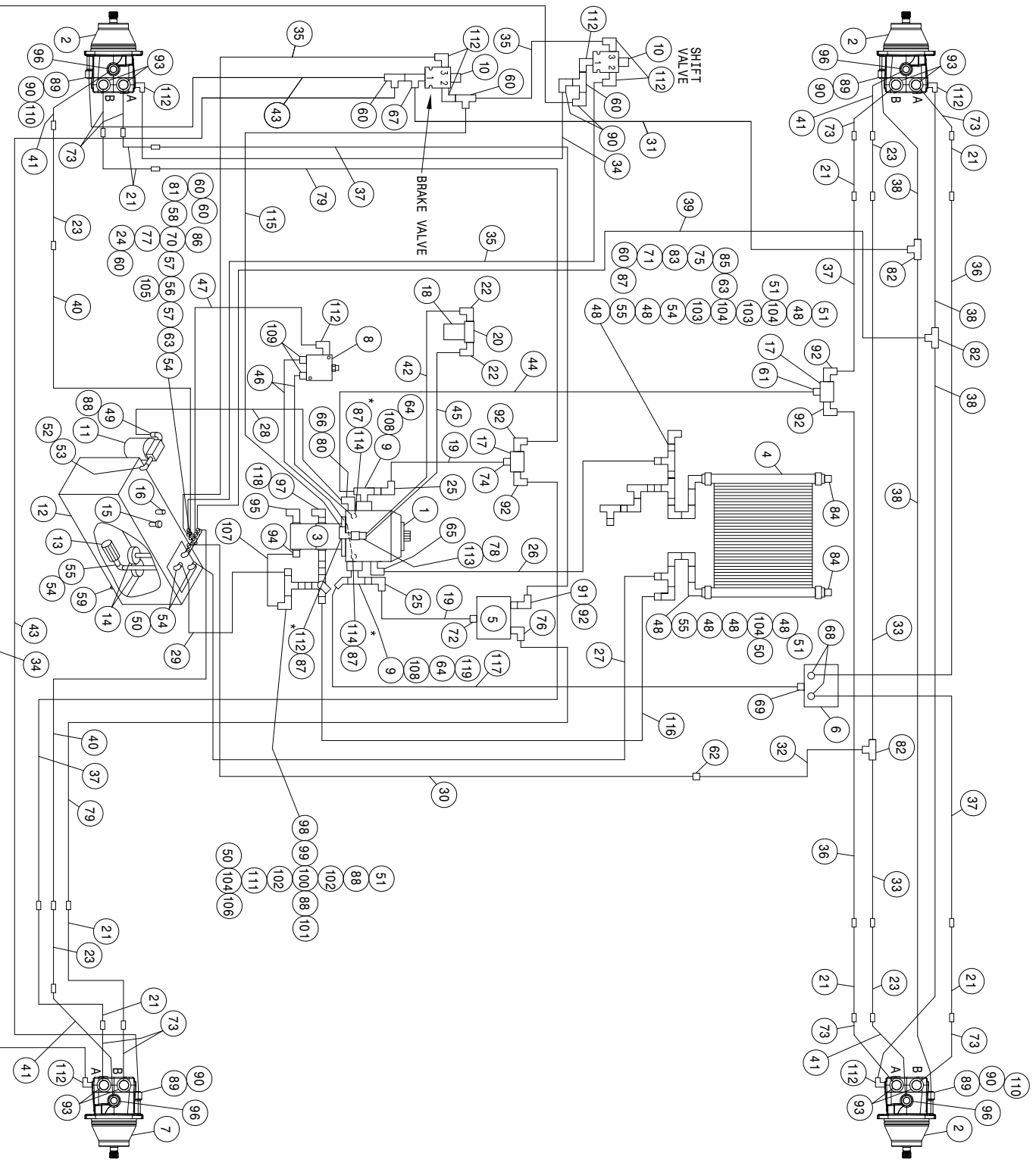

204SP BASIC MACHINE CUMM HYD SCHEM 11
REFERENCE DRAWING NO. 49910851

DET.	QTY	PART NO.	DESCRIPTION	DET.	QTY	PART NO.	DESCRIPTION
1	1	607572	SUND 100CC PUMP,23T B-MT /FILT	61	1	618558	1 5/16MJIC-1 1/16MOR ADPTR
2	3	606193	SAUER WHL MOTOR,KC-38CC	62	1	618551	3/4MJIC-9/16MJIC REDU UNION
3	1	606352	TANDEM PUMP,606353 & 606929	63	2	505213	RED BUSH 1 X 3/4 BLK MAL
4	1	618606	OIL COOLER, BLISSFIELD 65027	64	2	618541	1 5/16FJIC-1 1/16MJIC ADPTR
5	1	610609	TRACTION VLV,STL,66S,40GPM	65	1	618118	3/4 HOSE BARB-90-1 1/16MOR
6	1	610586	POSITRACTION VLV,STL,88SP 60G	66	1	618638	IIN HOSE BARB-45-1 5/16MOR
7	1	606203	SAUER WHL MOTOR, KC-38CC W/SEN	67	1	618444	9/16MOR RUN TEE-9/16MJIC
8	1	610580	REMOTE FLUSHING VALVE, SUND	68	2	618601	7/8MJIC-1 5/16MOR ADPT
9	2	618598	1" 4-BOLT FLG X 1 5/16 FOR	69	1	618186	1 5/16MJIC-1 5/16MOR ADPTR
10	2	610318	HYD SOLE VLV,2P-3M,9/16FOR,12V	70	1	504400	BLK PIPE CROSS .75NPT
11	1	605601	PARKER FILTER ASSY,10M,1.25NPT	71	1	618482	3/4FJIC-9/16MJIC ADPTR
12	1	760264	HYD TANK WLD,204/254/284 2002	72	1	618308	1 1/16MJIC-1 5/16MOR ADPTR
13	1	605600	TANK FILTER, 100 MESH,1"FNPT	73	8	616433	10-381-10MJ-10FJX45-17
14	2	605603	LINE SUMP DIFFUSER	74	1	611127	1 1/16MJIC-1 1/16MOR ADPTR
15	1	611052	FILLER BREATHER 3/4NPT	75	1	618451	3/4FJIC SW RUN TEE-3/4MJIC
16	1	614453	DIPSTICK, 8IN	76	1	618589	7/8MJIC-90-1 5/16MOR LBO
17	2	606356	1 1/16FOR MANIFOLD, 3 #12PORTS	77	1	504001	RED BUSH 3/4 X 1/4 BLK MAL
18	1	605609	HYD FILTER ELEMENT, DONALDSON	78	1	618183	3/4MJIC-90-7/8MOR LBO
19	2	614707	HYD TUBE ASSY,SUND,200 DIESEL	79	2	616297	08-381-10MJ-10FJX-88
20	1	605608	HYD FILTER HEAD, DONALDSON	80	1	618639	1 5/8MOR-1 5/16FOR ADPTR
21	8	618440	LEG HYD TUBE ASSY, 204SP 07	81	1	618018	9/16MJIC-1/2MNP ADPTR
22	2	618474	3/4MJIC-90-1 1/16MOR LBO	82	3	618019	9/16MJIC UNION TEE
23	4	615841	LEG CASE DRN TUBE ASSY,204SP07	83	1	618609	3/4MJIC-90-3/4FJIC SWIV LBO
24	1	618520	1/4MNP RUN TEE-9/16MJIC	84	2	505102	PIPE PLUG 1.00NPT SQ HD
25	2	618191	1 1/16MJ-90-1 1/16FJ SWIV LBO	85	1	610300	3/4MJIC-3/4MNP ADPTR
26	1	601735	HOSE, 3/4 X 93 1FBR-1SPI	86	1	618135	3/4 HOSE BARB-90-3/4MNP
27	1	601396	HOSE, 1 X 81 1FBR-1SPI	87	4	618531	9/16FJIC CAP NUT
28	1	601732	HOSE, 1 X 26 1FBR-1SPI	88	3	506410	BLK PIPE ST EL 90DEG 1.25NPT
29	1	601733	HOSE, 1 X 40 1FBR-1SPI	89	4	618304	9/16MJIC-7/16MOR ADPTR
30	1	614388	08-4822TC-06FJX-08FJX-129	90	6	618618	9/16MJIC-90-9/16FJIC SWIV LBO
31	1	611246	04-4822TC-06FJX-06FJX-174	91	1	618312	1 5/16MOR-1 1/16FOR ADPTR
32	1	614625	06C1T-06FJX-06FJX-50	92	5	618535	7/8MJIC-90-1 1/16MOR LBO
33	2	616156	06-4822TC-08MJ-06FJX-92	93	8	618786	7/8MJIC-45-1 1/16MOR LBO
34	2	614152	04-4822TC-06FJX-06FJX-114	94	1	618075	3/4 HOSE BARB-1 1/16MOR
35	3	614713	04-4822TC-06FJX-06FJX-24	95	1	611128	7/8MJIC-90-7/8MOR LBO
36	2	616160	08-381-10MJ-10FJX-105	96	4	618315	3/4MJIC-45-3/4MOR LBO
37	4	616159	08-381-10MJ-10FJX-98	97	1	618472	1 5/8MJIC-1 5/8MOR ADPTR
38	4	611202	04-4822TC-06FJX-06FJX-136	98	1	618816	1 7/8MOR-1 1/4FNPT ADPTR
39	2	611212	04-4822TC-06FJX-06FJX-164	99	1	507026	1 1/4MNP HEX PIPE NIPPLE STL
40	2	616157	06-4822TC-08MJ-06FJX-106	100	1	506202	BLK PIPE CROSS 1.25NPT
41	4	616432	08-381-08MJ-08FJX45-15	101	1	715660	HOSE BARB 1 1/4NPT X 1 1/4
42	1	615633	08-4822TC-08FJX-08FJX-23	102	2	506005	1 1/4 TO 1 RED BUSH BLK MAL
43	2	614639	04-4822TC-06FJX-06FJX-126	103	2	505201	CLOSE NIPPLE 1.00NPT
44	2	616933	12-721-16FJX-16FJX-114	104	4	505101	BLK PIPE TEE 1.00NPT
45	1	616034	08-4822TC-08FJX-08FJX-17	105	1	610305	3/4MJIC-90-3/4MNP LBO
46	2	616253	04-381-06FJX-06FJX-23	106	1	716000	3/4 HOSE BARB-90-1MNP
47	1	616048	04-4822TC-06FJX-06FJX-35	107	1	601399	HOSE, 3/4 X 13 1FBR-1SPI
48	7	505200	BLK PIPE ST EL 90DEG 1.00NPT	108	2	618599	1 5/16MOR BRANCH TEE-1 5/16MJ
49	1	715664	1 1/4 NPT X 1 HOSE BARB	109	2	618126	9/16MJIC-9/16MOR ADPTR
50	4	714560	1NPT X 1 HOSE BARB	110	2	618634	9/16MJIC-45-9/16FJIC SWIV LBO
51	4	714331	1 NPT X 3/4 HOSE BARB	111	1	505105	1MNP HEX PIPE NIPPLE STL
52	1	506602	PIPE NIPPLE 1 1/4NPT-2 1/2	112	11	618119	9/16MJIC-90-9/16MOR LBO
53	1	506303	BLK PIPE EL 90DEG 1.25NPT	113	1	618327	3/4MJIC-7/8MOR ADPTR
54	5	505300	BLK PIPE EL 90DEG 1.00NPT	114	2	618629	9/16MOR BRANCH TEE-9/16MJIC
55	3	505203	BLK PIPE NIPPLE 1.00NPT-4.00	115	1	616056	04-4822TC-06FJX-06FJX-52
56	1	504955	BLK PIPE TEE .75NPT	116	1	601734	HOSE, 3/4 X 66 1FBR-1SPI
57	1	504702	CLOSE NIPPLE .75NPT	117	1	616934	12-721-16FJX-16FJX-117
58	2	504210	RED BUSH 3/4 NPT X 1/2 NPT	118	1	618851	1 5/8MJIC-90-1 5/8FJX TUBE FTG
59	1	470308	1/2MNP DRAIN PLUG,AL HD,MAG	119	1	618630	1 5/16MJ-45-1 5/16FJ SWIV LBO
60	7	618486	9/16FJIC SW RUN TEE-9/16MJIC				

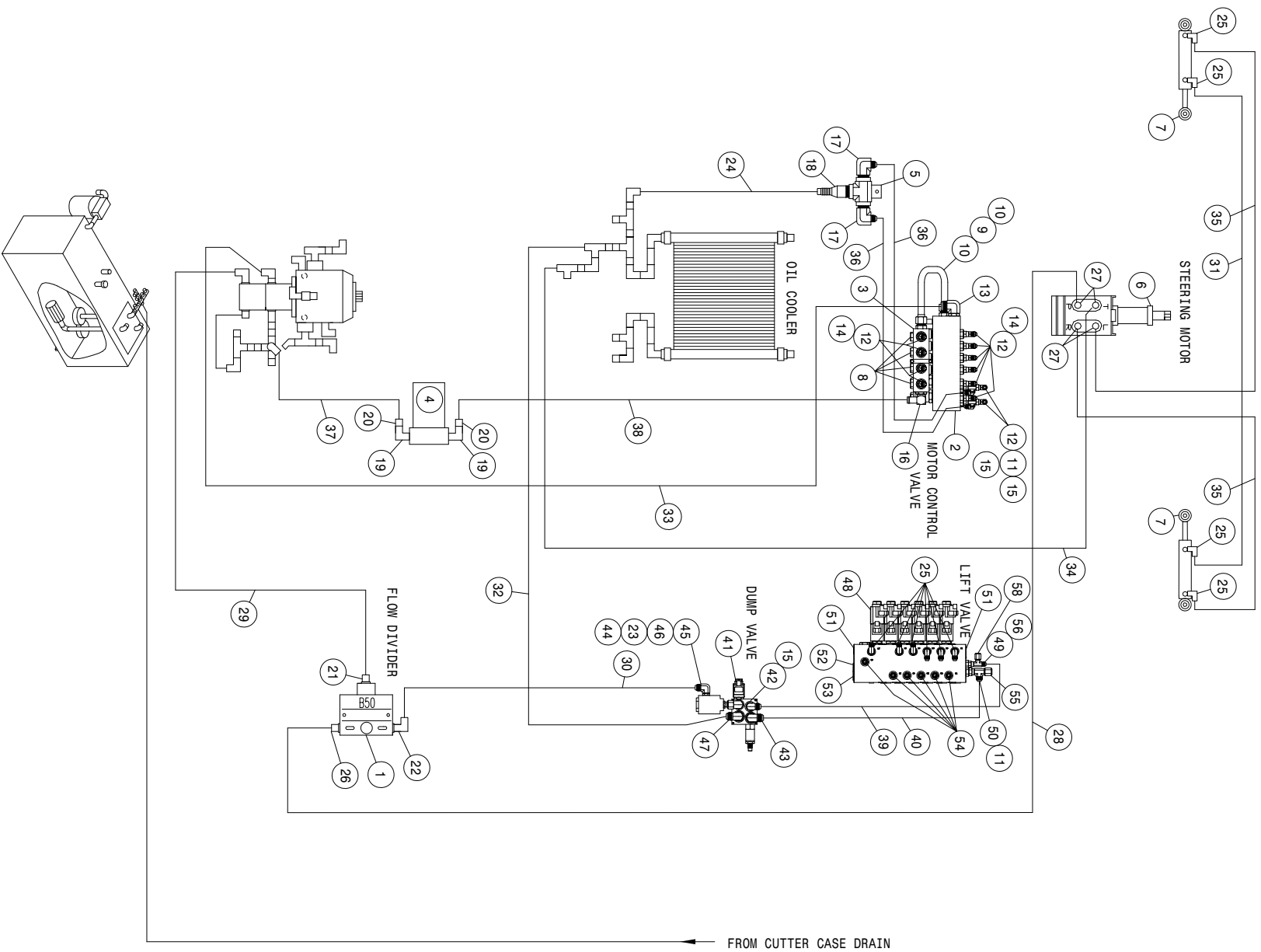

204SP BASIC MACHINE CUMM HYD SCHEM 11
REFERENCE DRAWING NO. 499108S2

DET.	QTY	PART NO.	DESCRIPTION	DET.	QTY	PART NO.	DESCRIPTION
1	1	607504	FLO DIV B50 2-8GPM 7/8 FOR	30	1	615473	06-482TC-06FJX-08FJX-18
2	1	606262	MTR CONTROL ELECT VLV, SAUER 07	31	1	611246	04-482TC-06FJX-06FJX-174
3	1	606029	RETURN MANIFOLD BLOCK, STS 03	32	1	616006	08-482TC-08FJX-10FJX-33
4	1	605633	PARKER FILTER ASSY, 25M, 1.25NPT	33	1	616257	20-381-20FJX-20FJX-144
5	1	614660	1IN STL TEE WLD 280 89	34	1	611204	04-482TC-06FJX-06FJX-78
6	1	749318	STRG MTR, 7.3CID, NON-LOAD 1031	35	2	614639	04-482TC-06FJX-06FJX-126
7	2	621516	HYD CYL, 2.00 X 7.00 X 1.000	36	2	615633	08-482TC-08FJX-08FJX-23
8	4	610186	1 1/16MOR PLUG, HEX HEAD	37	1	601436	HOSE, 3/4 X 15 1BR BLK EPDM
9	1	615799	MTR CTRL RET TUBE ASSY, 204 07	38	1	601737	HOSE, 1 1/4 X 162 1FBR-1SP1
10	2	618186	1 5/16MJIC-1 5/16MOR ADPTR	39	1	616008	06C1T-08FJX-06FJX90-52
11	3	618451	3/4FJIC SW RUN TEE-3/4MJIC	40	1	616007	08C1T-08FJX-10FJX-50
12	12	618469	3/4MJIC-1 1/16MOR ADPTR	41	1	606330	DUMP MANIF VALVE SAUER
13	1	618476	1 5/8MJIC-90-1 5/16MOR LBO	42	1	611125	3/4MJIC-3/4MOR ADPTR
14	10	618590	3/4MJIC-45-3/4FJIC SWIV LBO	43	1	611128	7/8MJIC-90-7/8MOR LBO
15	5	618609	3/4MJIC-90-3/4FJIC SWIV LBO	44	1	618249	3/4MJIC-90-9/16MOR LBO
16	1	618772	1 1/4 HOSE BARB-90-1 5/16MOR	45	1	618464	3/4MJIC-90-3/4MOR LG LBO
17	2	618714	3/4MJIC-90-1"MNPT LBO	46	1	618692	3/4FJIC SWIV-9/16MOR ADPTR
18	1	714331	1 NPT X 3/4 HOSE BARB	47	1	618774	7/8MJIC-90-7/8MOR LG LBO
19	2	506410	BLK PIPE ST EL 90DEG 1.25NPT	48	1	606285	LIFT VALVE, STS COMBO, SAUER
20	2	715660	HOSE BARB 1 1/4NPT X 1 1/4	49	1	618109	9/16MJIC-3/4MOR ADPTR
21	1	611126	7/8MJIC-7/8MOR ADPTR	50	1	618327	3/4MJIC-7/8MOR ADPTR
22	1	618600	9/16MJIC-90-7/8MOR LBO	51	2	618754	9/16MOR PLUG, HEX SOCKET
23	1	605615	HYD FILTER, INLINE 25M 9/16FOR	52	1	618755	3/4MOR PLUG, HEX SOCKET
24	1	601632	HOSE, 3/4 X 72 1FBR-1SP1	53	1	618756	7/8MOR PLUG, HEX SOCKET
25	10	618119	9/16MJIC-90-9/16MOR LBO	54	6	618126	9/16MJIC-9/16MOR ADPTR
26	1	618310	9/16MJIC-7/8MOR ADPTR	55	1	618532	3/4FJIC CAP NUT
27	4	618496	9/16MJIC-45-3/4MOR LBO	56	1	618486	9/16FJIC SW RUN TEE-9/16MJIC
28	1	615727	04-482TC-06FJX-06FJX-75	57	1	618531	9/16FJIC CAP NUT
29	1	616147	10-482TC-10FJX-10FJX-89				H/A

204SP WIDE BASIC MACHINE CUMM HYD SCHEM 11
REFERENCE DRAWING NO. 499067S1

DET.	QTY	PART NO.	DESCRIPTION	DET.	QTY	PART NO.	DESCRIPTION
1	1	607572	SUND 100CC PUMP,23T B-MT /FILT	61	1	618558	1 5/16MJIC-1 1/16MOR ADPTR
2	3	606193	SAUER WHL MOTOR,KC-38CC	62	1	618551	3/4MJIC-9/16MJIC REDU UNION
3	1	606352	TANDEM PUMP,606353 & 606929	63	2	505213	RED BUSH 1 X 3/4 BLK MAL
4	1	618606	OIL COOLER, BLISSFIELD 65027	64	2	618541	1 5/16FJIC-1 1/16MJIC ADPTR
5	1	610609	TRACTION VLV,STL,66S,40GPM	65	1	618118	3/4 HOSE BARB-90-1 1/16MOR
6	1	610586	POSITRACTION VLV,STL,88SP 60G	66	1	618638	1IN HOSE BARB-45-1 5/16MOR
7	1	606203	SAUER WHL MOTOR, KC-38CC	67	1	618444	9/16MOR RUN TEE-9/16MJIC
8	1	610580	REMOTE FLUSHING VALVE, SUND	68	2	618601	7/8MJIC-1 5/16MOR ADPT
9	2	618598	1" 4-BOLT FLG X 1 5/16 FOR	69	1	618186	1 5/16MJIC-1 5/16MOR ADPTR
10	2	610318	HYD SOLE VLV,2P-3M,9/16FOR,12V	70	1	504400	BLK PIPE CROSS .75NPT
11	1	605601	PARKER FILTER ASSY,10M,1.25NPT	71	1	618482	3/4FJIC-9/16MJIC ADPTR
12	1	760264	HYD TANK WLD,204/254/284 2002	72	1	618308	1 1/16MJIC-1 5/16MOR ADPTR
13	1	605600	TANK FILTER, 100 MESH,1"FNPT	73	8	616433	10-381-10MJ-10FJX45-17 H/A
14	2	605603	LINE SUMP DIFFUSER	74	1	611127	1 1/16MJIC-1 1/16MOR ADPTR
15	1	611052	FILLER BREATHER 3/4NPT	75	1	618451	3/4FJIC SW RUN TEE-3/4MJIC
16	1	614453	DIPSTICK, 8IN	76	1	618589	7/8MJIC-90-1 5/16MOR LBO
17	2	606356	1 1/16FOR MANIFOLD,3 #12PORTS	77	1	504001	RED BUSH 3/4 X 1/4 BLK MAL
18	1	605609	HYD FILTER ELEMENT, DONALDSON	78	1	618183	3/4MJIC-90-7/8MOR LBO
19	2	614707	HYD TUBE ASSY,SUND,200 DIESEL	79	2	616639	08-381-10MJ-10FJX-95
20	1	605608	HYD FILTER HEAD, DONALDSON	80	1	618639	1 5/8MOR-1 5/16FOR ADPTR
21	8	615840	LEG HYD TUBE ASSY, 204SP 07	81	1	618018	9/16MJIC-1/2MNP ADPTR
22	2	618474	3/4MJIC-90-1 1/16MOR LBO	82	3	618019	9/16MJIC UNION TEE
23	4	615841	LEG CASE DRN TUBE ASSY,204SP07	83	1	618609	3/4MJIC-90-3/4FJIC SWIV LBO
24	1	618520	1/4MNP RUN TEE-9/16MJIC	84	2	505102	PIPE PLUG 1.00NPT SQ HD
25	2	618191	1 1/16MJ-90-1 1/16FJ SWIV LBO	85	1	610300	3/4MJIC-3/4MNP ADPTR
26	1	601735	HOSE, 3/4 X 93 1FBR-1SPI	86	1	618135	3/4 HOSE BARB-90-3/4MNP
27	1	601396	HOSE, 1 X 81 1FBR-1SPI	87	4	618531	9/16FJIC CAP NUT
28	1	601732	HOSE, 1 X 26 1FBR-1SPI	88	3	506410	BLK PIPE ST EL 90DEG 1.25NPT
29	1	601733	HOSE, 1 X 40 1FBR-1SPI	89	4	618304	9/16MJIC-7/16MOR ADPTR
30	1	614388	08-482TC-08FJX-08FJX-129	90	6	618618	9/16MJIC-90-9/16FJIC SWIV LBO
31	1	611246	04-482TC-06FJX-06FJX-174	91	1	618312	1 5/16MOR-1 1/16FOR ADPTR
32	1	614625	06C1T-06FJX-06FJX-30	92	5	618535	7/8MJIC-90-1 1/16MOR LBO
33	2	616637	04-482TC-08MJ-06FJX-99	93	8	618786	7/8MJIC-45-1 1/16MOR LBO
34	1	616635	04-482TC-06FJX-06FJX-121	94	1	618075	3/4 HOSE BARB-1 1/16MOR
35	3	614713	04-482TC-06FJX-06FJX-24	95	1	611128	7/8MJIC-90-7/8MOR LBO
36	2	616640	08-381-10MJ-10FJX-112	96	4	618315	3/4MJIC-45-3/4MOR LBO
37	4	616160	08-381-10MJ-10FJX-105	97	1	618472	1 5/8MJIC-1 5/8MOR ADPTR
38	4	616636	04-482TC-06FJX-06FJX-143	98	1	618816	1 7/8MOR-1 1/4FNPT ADPTR
39	1	611212	04-482TC-06FJX-06FJX-164	99	1	507026	1 1/4MNP HEX PIPE NIPPLE STL
40	2	616638	06-482TC-08MJ-06FJX-113	100	1	506202	BLK PIPE CROSS 1.25NPT
41	4	616432	08-381-08MJ-08FJX45-15	101	1	715660	HOSE BARB 1 1/4NPT X 1 1/4
42	1	615633	08-482TC-08FJX-08FJX-23	102	2	506005	1 1/4 TO 1 RED BUSH BLK MAL
43	2	614101	04-482TC-06FJX-06FJX-133	103	2	505201	CLOSE NIPPLE 1.00NPT
44	1	616933	12-721-16FJX-16FJX-114	104	4	505101	BLK PIPE TEE 1.00NPT
45	1	616034	08-482TC-08FJX-08FJX-17	105	1	610305	3/4MJIC-90-3/4MNP LBO
46	2	616233	04-381-06FJX-06FJX-23	106	1	716000	3/4 HOSE BARB-90-1MNP
47	1	616048	04-482TC-06FJX-06FJX-35	107	1	601399	HOSE, 3/4 X 13 1FBR-1SPI
48	7	505200	BLK PIPE ST EL 90DEG 1.00NPT	108	2	618599	1 5/16MOR BRANCH TEE-1 5/16MJ
49	1	715664	1 1/4 NPT X 1 HOSE BARB	109	2	618126	9/16MJIC-9/16MOR ADPTR
50	4	714560	1NPT X 1 HOSE BARB	110	2	618634	9/16MJIC-45-9/16FJIC SWIV LBO
51	4	714331	1 NPT X 3/4 HOSE BARB	111	1	505105	1MNP HEX PIPE NIPPLE STL
52	1	506602	PIPE NIPPLE 1 1/4NPT-2 1/2	112	11	618119	9/16MJIC-90-9/16MOR LBO
53	1	506303	BLK PIPE EL 90DEG 1.25NPT	113	1	618327	3/4MJIC-7/8MOR ADPTR
54	5	505300	BLK PIPE EL 90DEG 1.00NPT	114	2	618629	9/16MOR BRANCH TEE-9/16MJIC
55	3	505203	BLK PIPE NIPPLE 1.00NPT-4.00	115	1	616056	04-482TC-06FJX-06FJX-32 H/A
56	1	504955	BLK PIPE TEE .75NPT	116	1	601734	HOSE, 3/4 X 66 1FBR-1SPI
57	2	504702	CLOSE NIPPLE .75NPT	117	1	616934	12-721-16FJX-16FJX-117 H/A
58	1	504210	RED BUSH 3/4 NPT X 1/2 NPT	118	1	618851	1 5/8MJIC-90-1 5/8FJX TUBE FTG
59	1	470308	1/2MNP DRAIN PLUG,AL HD,MAG	119	1	618630	1 5/16MJ-45-1 5/16FJ SWIV LBO
60	7	618486	9/16FJIC SW RUN TEE-9/16MJIC				

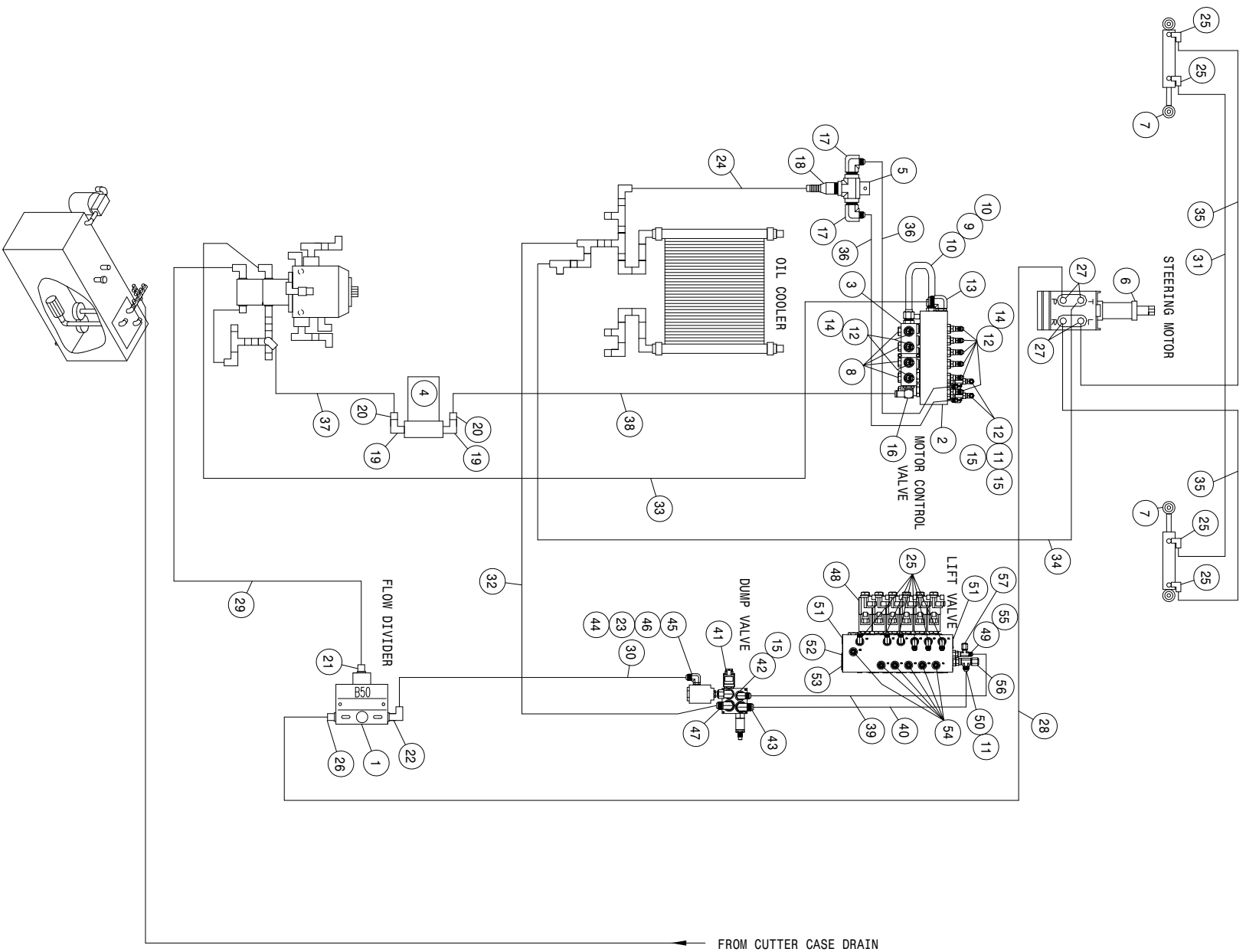

204SP WIDE BASIC MACHINE CUMM HYD SCHEM 11
REFERENCE DRAWING NO. 499067S2

DET.	QTY	PART NO.	DESCRIPTION	DET.	QTY	PART NO.	DESCRIPTION
1	1	607504	FLO DIV B50 2-8GPM 7/8 FOR	30	1	615473	06-482TC-06FJX-08FJX-18
2	1	606262	MTR CONTROL ELECT VLV, SAUER 07	31	1	611246	04-482TC-06FJX-06FJX-174
3	1	606029	RETURN MANIFOLD BLOCK, STS 03	32	1	616006	08-482TC-08FJX-10FJX-33
4	1	605633	PARKER FILTER ASSY, 25M, 1.25NPT	33	1	616257	20-381-20FJX-20FJX-144
5	1	614660	1IN STL TEE WLD 280 89	34	1	611204	04-482TC-06FJX-06FJX-78
6	1	749318	STRG MTR, 7.3CID, NON-LOAD 1031	35	2	614639	04-482TC-06FJX-06FJX-126
7	2	621516	HYD CYL, 2.00 X 7.00 X 1.000	36	2	615633	08-482TC-08FJX-08FJX-23
8	4	610186	1 1/16MOR PLUG, HEX HEAD	37	1	601736	HOSE, 1 1/4 X 58 1FBR-1SPI
9	4	615799	MTR CTRL RET TUBE ASSY, 204 07	38	1	601737	HOSE, 1 1/4 X 162 1FBR-1SPI
10	2	618186	1 5/16MJC-1 5/16MOR ADPTR	39	1	616008	06C1T-08FJX-06FJX90-52
11	3	618451	3/4FJIC SW RUN TEE-3/4MJC	40	1	616007	08C1T-08FJX-10FJX-50
12	12	618469	3/4MJC-1 1/16MOR ADPTR	41	1	606330	DUMP MANIF VALVE
13	1	618476	1 5/8MJC-90-1 5/16MOR LBO	42	1	611125	3/4MJC-3/4MOR ADPTR
14	10	618590	3/4MJC-45-3/4FJIC SMIV LBO	43	1	611128	7/8MJC-90-7/8MOR LBO
15	5	618609	3/4MJC-90-3/4FJIC SWIV LBO	44	1	618249	3/4MJC-90-9/16MOR LBO
16	1	618772	1 1/4 HOSE BARB-90-1 5/16MOR	45	1	618464	3/4MJC-90-3/4MOR LG LBO
17	2	618714	3/4MJC-90-1"MNPT LBO	46	1	618692	3/4FJIC SMIV-9/16MOR ADPTR
18	1	714331	1 NPT X 3/4 HOSE BARB	47	1	618774	7/8MJC-90-7/8MOR LG LBO
19	2	506410	BLK PIPE ST EL 90DEG 1.25NPT	48	1	606285	LIFT VALVE, STS COMBO, SAUER
20	2	715660	HOSE BARB 1 1/4NPT X 1 1/4	49	1	618109	9/16MJC-3/4MOR ADPTR
21	1	611126	7/8MJC-7/8MOR ADPTR	50	1	618327	3/4MJC-7/8MOR ADPTR
22	1	618600	9/16MJC-90-7/8MOR LBO	51	2	618754	9/16MOR PLUG, HEX SOCKET
23	1	605615	HYD FILTER, INLINE 25M 9/16FOR	52	1	618755	3/4MOR PLUG, HEX SOCKET
24	1	601632	HOSE, 3/4 X 72 1FBR-1SPI	53	1	618756	7/8MOR PLUG, HEX SOCKET
25	10	618119	9/16MJC-90-9/16MOR LBO	54	6	618126	9/16MJC-9/16MOR ADPTR
26	1	618310	9/16MJC-7/8MOR ADPTR	55	1	618486	9/16FJIC SW RUN TEE-9/16MJC
27	4	618496	9/16MJC-45-3/4MOR LBO	56	1	618532	3/4FJIC CAP NUT
28	1	615727	04-482TC-06FJX-06FJX-75	57	1	618531	9/16FJIC CAP NUT
29	1	616147	10-482TC-10FJX-10FJX-89				H/A

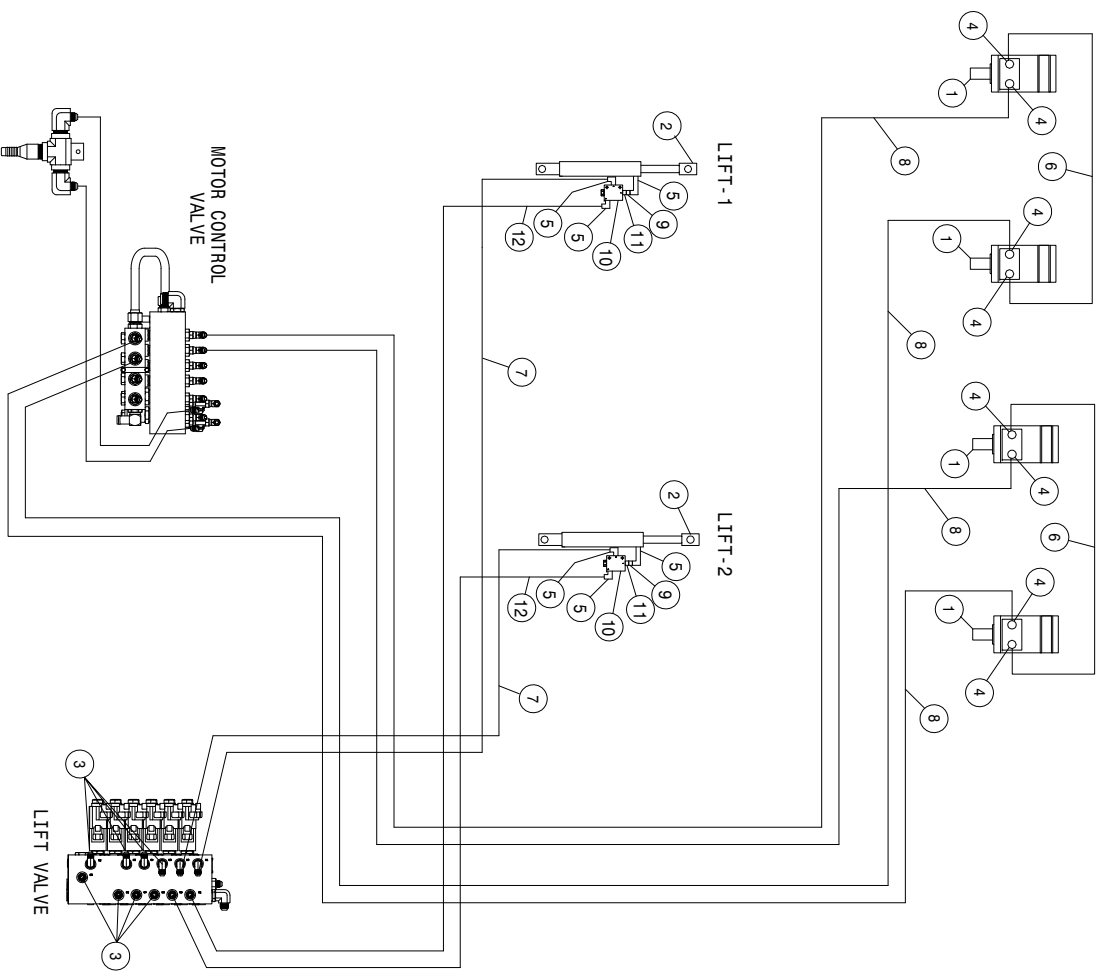

204 4R QUAD 2L LS HYD SCHEM 2011
 REFERENCE DRAWING NO. 499068

DET.	QTY	PART NO.	DESCRIPTION	DET.	QTY	PART NO.	DESCRIPTION
1	4	610547	HYD MOTOR 4.5CI 1IN SHFT	7	2	615729	04-482TC-06FJX-06FJX-84
2	2	621564	HYD CYL,2.00 X 11.00 X 1.50 1W	8	4	616168	08-482TC-08FJX-08FJX-139
3	8	618531	9/16FJIC CAP NUT	9	2	618733	9/16JIC .042 ORIFICE ADPTR
4	8	618327	3/4MJIC-7/8MOR ADPTR	10	2	607565	CHECK VLV,PILOT TO OPEN, SUN
5	6	618119	9/16MJIC-90-9/16MOR LBO	11	2	618668	9/16FJIC SWIV-9/16MOR ADPTR
6	2	616025	08-482TC-08FJX-08FJX-50	12	2	616861	04-451ITC-06FJX-06FJX90-88
			H/A				H/A

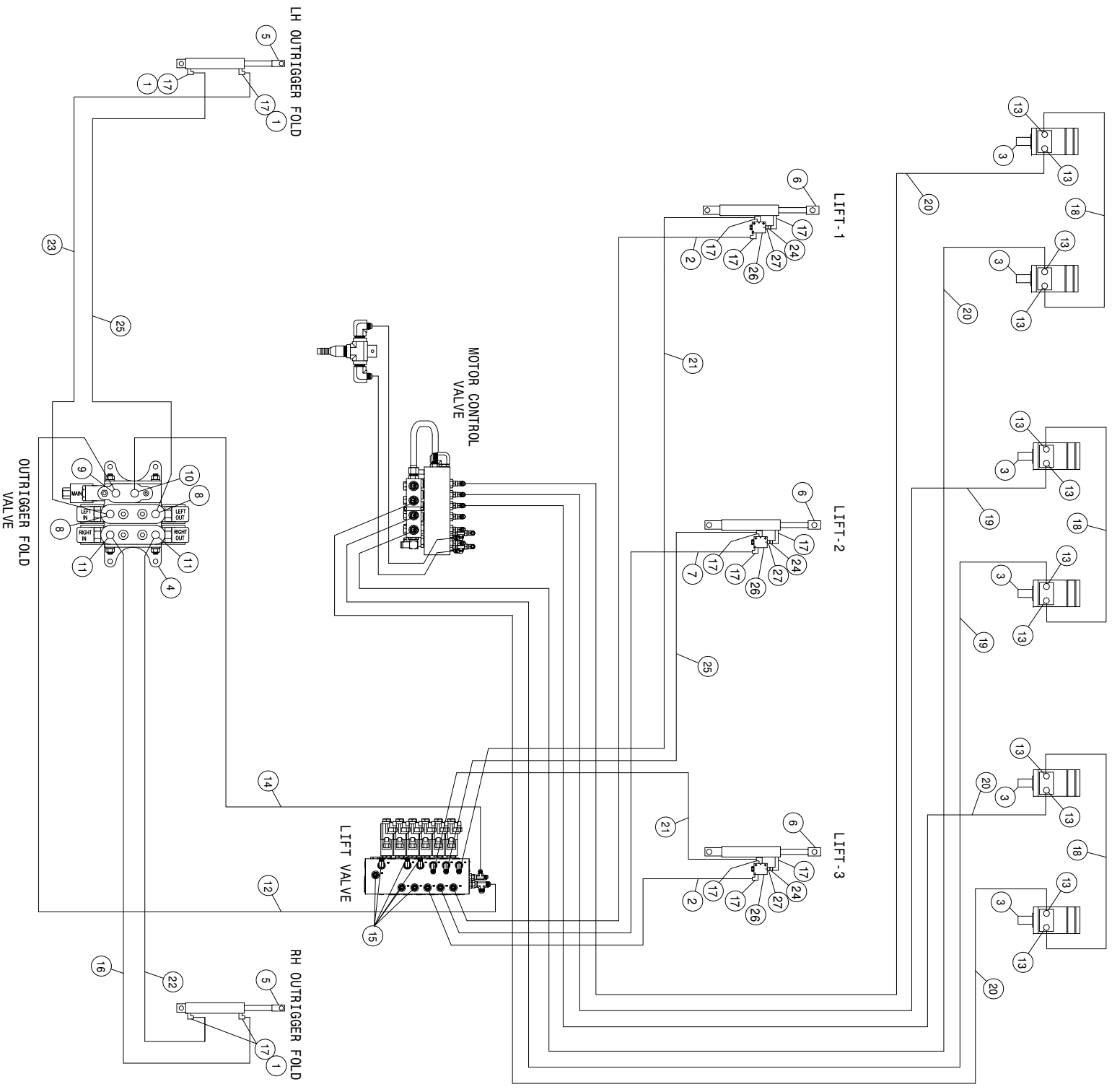

204SP 6R QUAD 3L LS HYD SCHEM 2011
REFERENCE DRAWING NO. 499069

DET.	QTY	PART NO.	DESCRIPTION	DET.	QTY	PART NO.	DESCRIPTION
1	4	618731	9/16JIC .025 ORIFICE ADPTR	15	6	618531	9/16FJIC CAP NUT
2	2	616864	04-451TC-06FJX-06FJX90-137 H/A	16	1	614152	04-482TC-06FJX-06FJX-114 H/A
3	6	610547	HYD MOTOR 4.5CI 1IN SHFT	17	13	618119	9/16MJIC-90-9/16MOR LBO
4	1	606090	BRAND HYD VALVE, 2-SECT SER 36	18	3	616025	08-482TC-08FJX-08FJX-50 H/A
5	2	621520	HYD CYL, 2.00 X 10.00 X 1.000	19	2	614689	08-482TC-08FJX-08FJX-120 H/A
6	3	621564	HYD CYL, 2.00 X 11.00 X 1.50 1W	20	4	614690	08-482TC-08FJX-08FJX-192 H/A
7	1	616862	04-451TC-06FJX-06FJX90-92 H/A	21	2	614101	04-482TC-06FJX-06FJX-135 H/A
8	2	618709	9/16MJIC-90-3/4MOR EX LG LBO	22	1	616205	04-482TC-06FJX-06FJX-117 H/A
9	1	618327	3/4MJIC-7/8MOR ADPTR	23	1	615727	04-482TC-06FJX-06FJX-75 H/A
10	1	618310	9/16MJIC-7/8MOR ADPTR	24	3	618733	9/16JIC .042 ORIFICE ADPTR
11	2	618115	9/16MJIC-90-3/4MOR LBO	25	2	614077	04-482TC-06FJX-06FJX-88 H/A
12	1	616505	08-451TC-08FJX-08FJX90-24 H/A	26	3	607565	CHECK VLV, PILOT TO OPEN, SUN
13	12	618327	3/4MJIC-7/8MOR ADPTR	27	3	618668	9/16FJIC SWIV-9/16MOR ADPTR
14	1	616117	06-451TC-06FJX-06FJX-17 H/A				

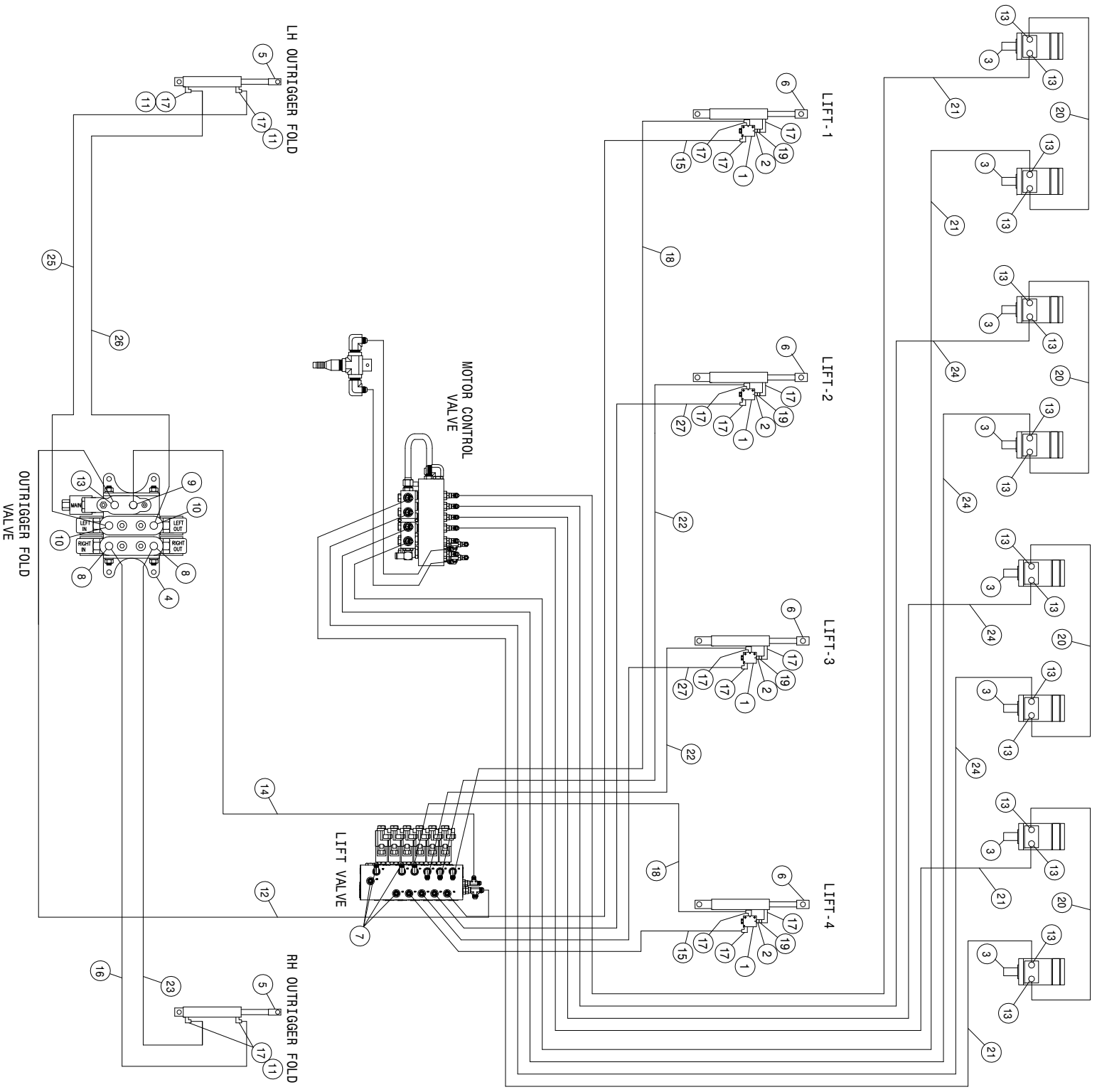

204SP 8R QUAD 4L LS HYD SCHEM 2011
REFERENCE DRAWING NO. 499070

DET.	QTY	PART NO.	DESCRIPTION	DET.	QTY	PART NO.	DESCRIPTION
1	4	607565	CHECK VLV,PILOT TO OPEN, SUN	15	2	616867	04-451TC-06FJX-06FJX90-186 H/A
2	4	618668	9/16FJIC SWIV-9/16MOR ADPTR	16	1	614152	04-482TC-06FJX-06FJX-114 H/A
3	8	610547	HYD MOTOR 4.5CI 1IN SHFT	17	16	618119	9/16MJIC-90-9/16MOR LBO
4	1	606090	BRAND HYD VALVE, 2-SECT SER 36	18	2	611262	04-482TC-06FJX-06FJX-182 H/A
5	2	621520	HYD CYL, 2.00 X 10.00 X 1.000	19	4	618733	9/16JIC .042 ORFICE ADPTR
6	4	621564	HYD CYL,2.00 X 11.00 X 1.50 1W	20	4	616025	08-482TC-08FJX-08FJX-50 H/A
7	4	618531	9/16FJIC CAP NUT	21	4	614384	08-482TC-08FJX-08FJX-237 H/A
8	2	618115	9/16MJIC-90-3/4MOR LBO	22	2	615729	04-482TC-06FJX-06FJX-84 H/A
9	1	618310	9/16MJIC-7/8MOR ADPTR	23	1	616205	04-482TC-06FJX-06FJX-117 H/A
10	2	618709	9/16MJIC-90-3/4MOR EX LG LBO	24	4	616168	08-482TC-08FJX-08FJX-139 H/A
11	4	618731	9/16JIC .025 ORFICE ADPTR	25	1	615727	04-482TC-06FJX-06FJX-75 H/A
12	1	616505	08-451TC-08FJX-08FJX90-24 H/A	26	1	614077	04-482TC-06FJX-06FJX-88 H/A
13	17	618327	3/4MJIC-7/8MOR ADPTR	27	2	616861	04-451TC-06FJX-06FJX90-88 H/A
14	1	616117	06-451TC-06FJX-06FJX-17 H/A				

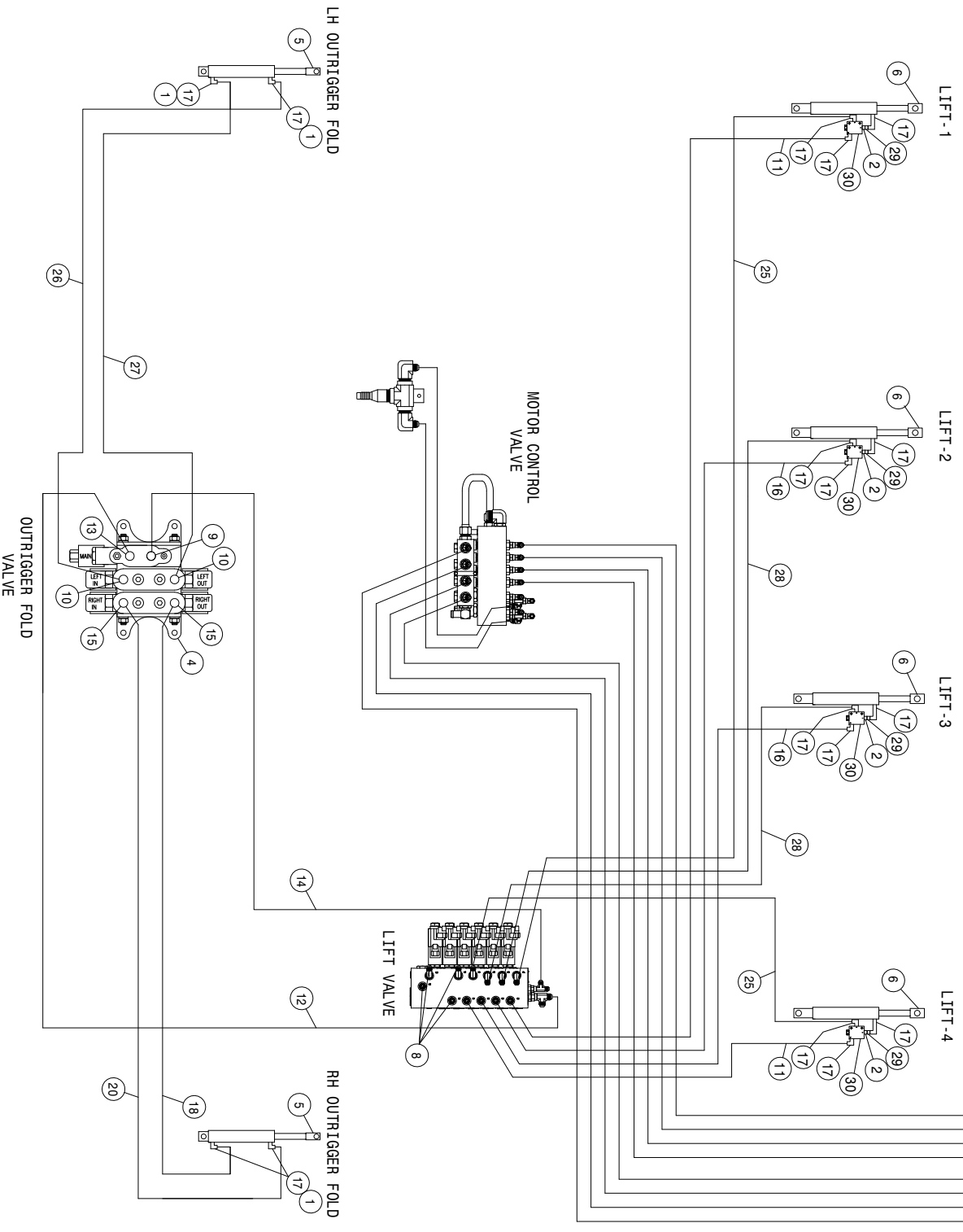
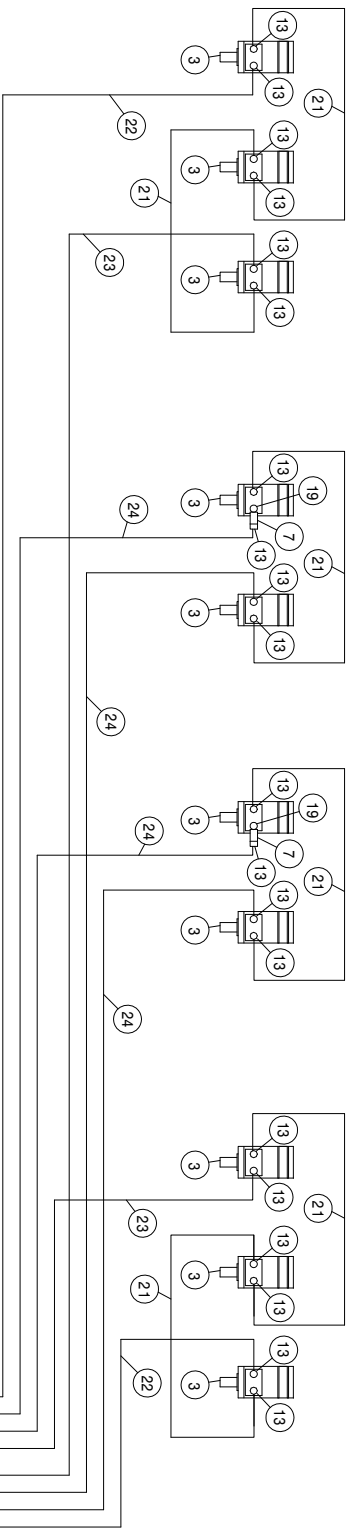

204SP 10R QUAD 4L LS HYD SCHEM 2011
REFERENCE DRAWING NO. 499071

DET.	QTY	PART NO.	DESCRIPTION	DET.	QTY	PART NO.	DESCRIPTION
1	4	618731	9/16JIC .025 ORIFICE ADPTR	16	2	616861	04-451TC-06FJX-06FJX90-88 H/A
2	4	618668	9/16FJIC SWIV-9/16MOR ADPTR	17	16	618119	9/16MJIC-90-9/16MOR LBO
3	10	610547	HYD MOTOR 4.5CI 1IN SHFT	18	1	616205	04-482TC-06FJX-06FJX-117 H/A
4	1	606090	BRAND HYD VALVE, 2-SECT SER 36	19	2	618586	7/8MOR UNION
5	2	621520	HYD CYL, 2.00 X 10.00 X 1.000	20	1	614152	04-482TC-06FJX-06FJX-114 H/A
6	4	621564	HYD CYL,2.00 X 11.00 X 1.50 1W	21	6	616025	08-482TC-08FJX-08FJX-50 H/A
7	2	607522	FLOW REGULATOR, 8GPM VONBERG	22	2	614387	08-482TC-08FJX-08FJX-267 H/A
8	4	618531	9/16FJIC CAP NUT	23	2	614384	08-482TC-08FJX-08FJX-139 H/A
9	1	618310	9/16MJIC-7/8MOR ADPTR	24	4	616168	08-482TC-08FJX-08FJX-201 H/A
10	2	618709	9/16MJIC-90-3/4MOR EX LG LBO	25	2	614098	04-482TC-06FJX-06FJX-75 H/A
11	2	616868	04-451TC-06FJX-06FJX90-205 H/A	26	1	615727	04-482TC-06FJX-06FJX-75 H/A
12	1	616505	08-451TC-08FJX-08FJX90-24 H/A	27	1	614077	04-482TC-06FJX-06FJX-88 H/A
13	21	618327	3/4MJIC-7/8MOR ADPTR	28	2	615729	04-482TC-06FJX-06FJX-84 H/A
14	1	616117	06-451TC-06FJX-06FJX-17 H/A	29	4	618733	9/16JIC .042 ORIFICE ADPTR
15	2	618115	9/16MJIC-90-3/4MOR LBO	30	4	607565	CHECK VLV,PILOT TO OPEN, SUN

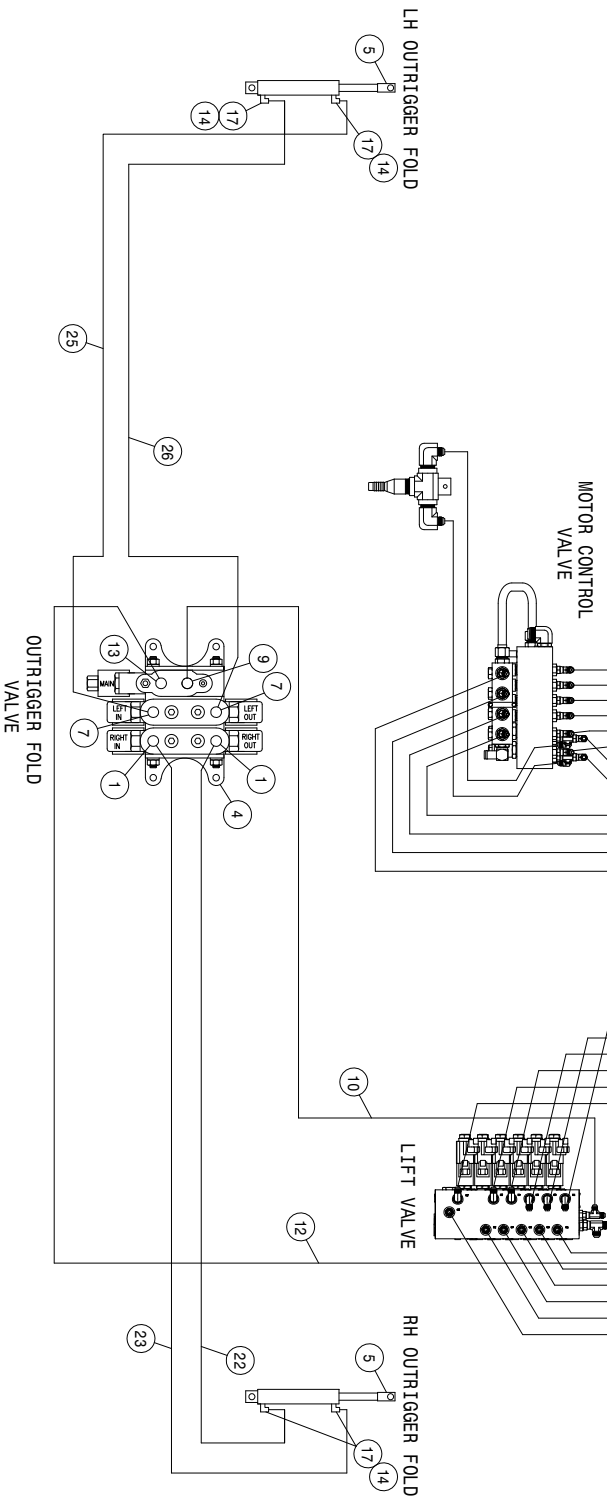
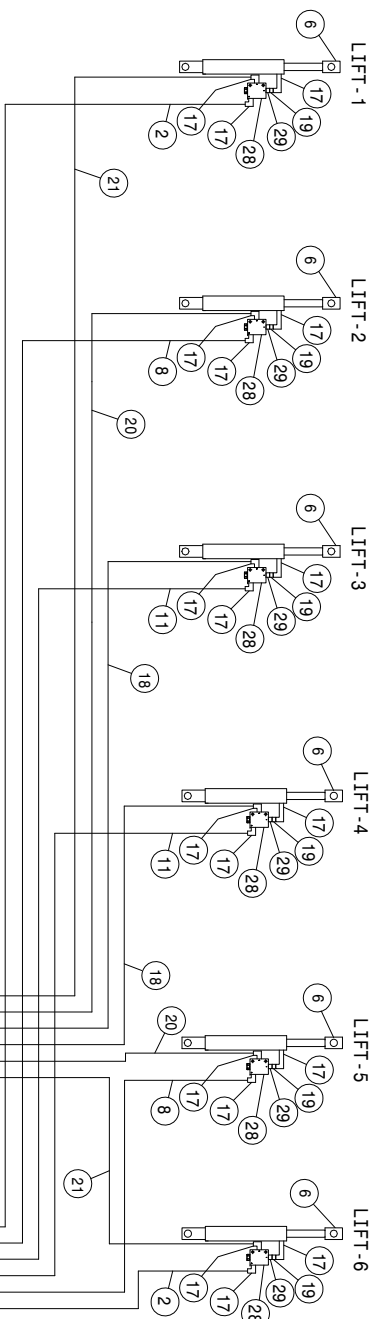
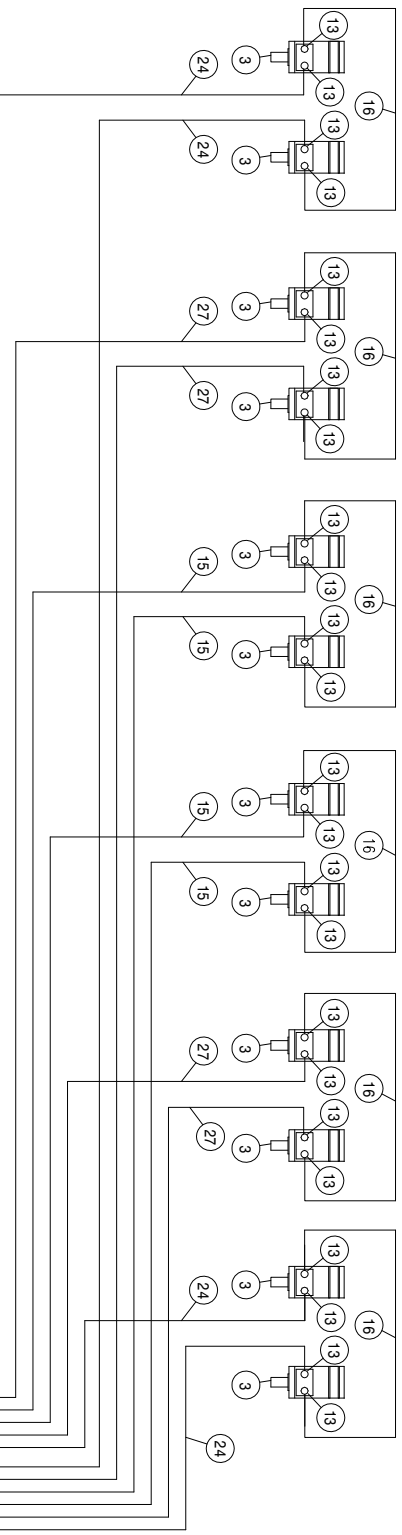

204SP 12R QUAD 6L LS HYD SCHEM 2011
REFERENCE DRAWING NO. 499072

DET.	QTY	PART NO.	DESCRIPTION	DET.	QTY	PART NO.	DESCRIPTION
1	2	618115	9/16MJIC-90-3/4MOR LBO	16	6	616025	08-482TC-08FJX-08FJX-50
2	2	616871	04-451TC-06FJX-06FJX90-262 H/A	17	22	618119	9/16MJIC-90-9/16MOR LBO
3	12	610547	HYD MOTOR 4.5CI 1IN SHFT	18	2	615729	04-482TC-06FJX-06FJX-84
4	1	606090	BRAND HYD VALVE, 2-SECT SER 36	20	2	611262	04-482TC-06FJX-06FJX-182
5	2	621520	HYD CYL, 2.00 X 10.00 X 1.000	21	2	614377	04-482TC-06FJX-06FJX-258
6	6	621564	HYD CYL, 2.00 X 11.00 X 1.50 1W	22	1	616205	04-482TC-06FJX-06FJX-117
7	2	618709	9/16MJIC-90-3/4MOR EX LG LBO	23	1	614152	04-482TC-06FJX-06FJX-114
8	2	616867	04-451TC-06FJX-06FJX90-186 H/A	24	4	616170	08-482TC-08FJX-08FJX-295
9	1	618310	9/16MJIC-7/8MOR ADPTR	25	1	615727	04-482TC-06FJX-06FJX-75
10	1	616117	06-451TC-06FJX-06FJX-17	26	1	614077	04-482TC-06FJX-06FJX-88
11	2	616861	04-451TC-06FJX-06FJX90-88	27	4	614384	08-482TC-08FJX-08FJX-237
12	1	616505	08-451TC-08FJX-08FJX90-24	28	6	607565	CHECK VLV,PILOT TO OPEN, SUN
13	25	618327	3/4MJIC-7/8MOR ADPTR	29	6	618668	9/16FJIC SWIV-9/16MOR ADPTR
14	4	618731	9/16JIC .025 ORIFICE ADPTR	29	6	618733	9/16JIC .042 ORIFICE ADPTR
15	4	616168	08-482TC-08FJX-08FJX-139				H/A

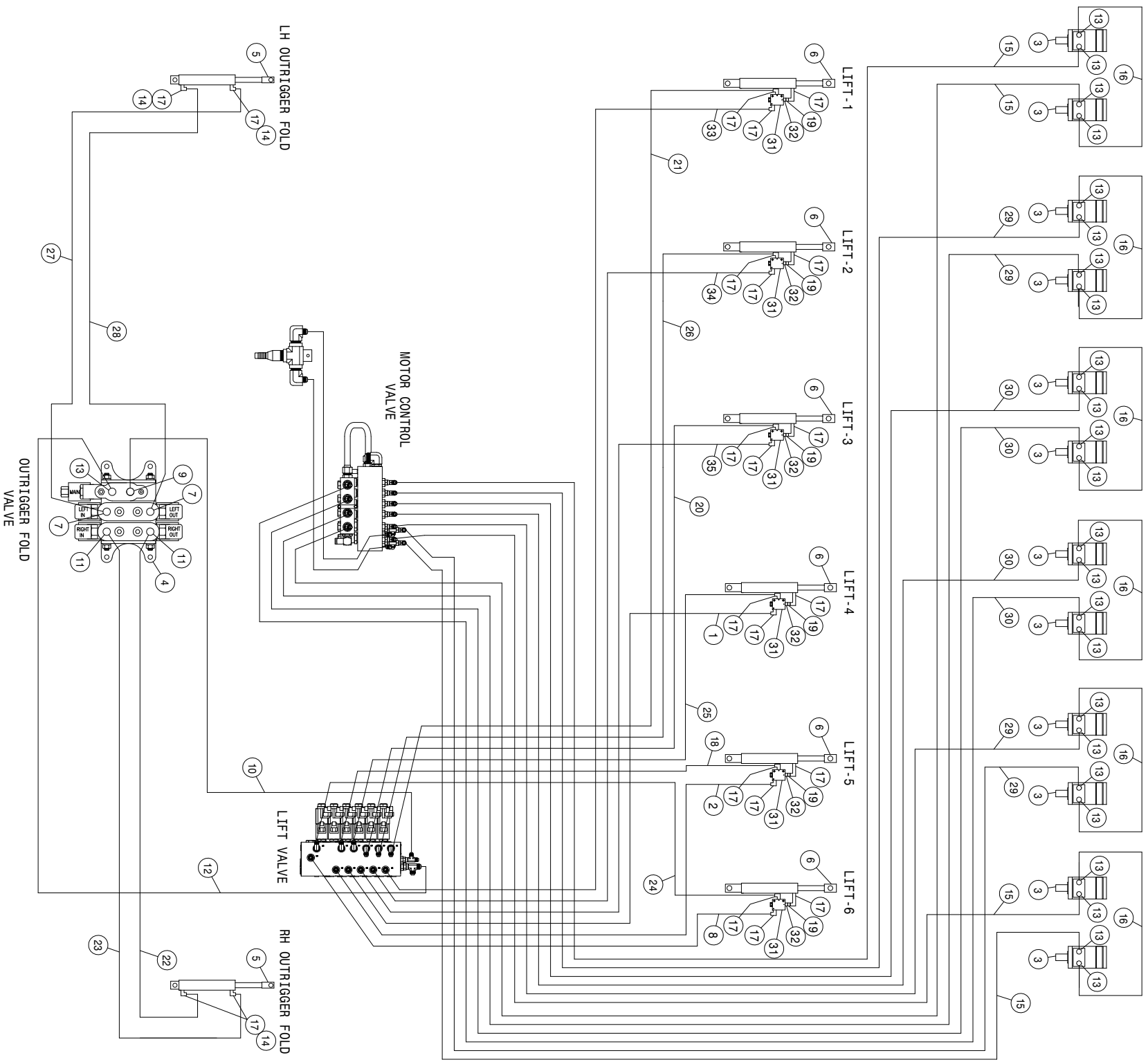

204SP 12R QUAD 52CM 6L LS HYD SCHEM 2011
REFERENCE DRAWING NO. 499073

DET.	QTY	PART NO.	DESCRIPTION	DET.	QTY	PART NO.	DESCRIPTION
1	1	616863	04-4511TC-06FJX-06FJX90-108 H/A	19	6	618733	9/16JIC .042 ORIFICE ADPTR
2	1	616866	04-4511TC-06FJX-06FJX90-178 H/A	20	1	614101	04-4821TC-06FJX-06FJX-133 H/A
3	12	610547	HYD MOTOR 4.5CI 1IN SHFT	21	1	614154	04-4821TC-06FJX-06FJX-221 H/A
4	1	606090	BRAND HYD VALVE, 2-SECT SER 36	22	1	616205	04-4821TC-06FJX-06FJX-117 H/A
5	2	621520	HYD CYL, 2.00 X 10.00 X 1.000	23	1	614152	04-4821TC-06FJX-06FJX-114 H/A
6	6	621564	HYD CYL, 2.00 X 11.00 X 1.50 1W	24	1	614303	04-4821TC-06FJX-06FJX-234 H/A
7	2	618709	9/16MJIC-90-3/4MOR EX LG LBO	25	1	611245	04-4821TC-06FJX-06FJX-104 H/A
8	1	616870	04-4511TC-06FJX-06FJX90-238 H/A	26	1	616191	04-4821TC-06FJX-06FJX-138 H/A
9	1	618310	9/16MJIC-7/8MOR ADPTR	27	1	615727	04-4821TC-06FJX-06FJX-75 H/A
10	1	616117	06-4511TC-06FJX-06FJX-117 H/A	28	1	614077	04-4821TC-06FJX-06FJX-88 H/A
11	2	618115	9/16MJIC-90-3/4MOR LBO	29	4	614690	08-4821TC-08FJX-08FJX-192 H/A
12	1	616505	08-4511TC-08FJX-08FJX90-24 H/A	30	4	614689	08-4821TC-08FJX-08FJX-120 H/A
13	25	618327	3/4MJIC-7/8MOR ADPTR	31	6	607565	CHECK VLV, PILOT TO OPEN, SUN
14	4	618731	9/16JIC .025 ORIFICE ADPTR	32	6	618668	9/16FJIC SWIV-9/16MOR ADPTR
15	4	616227	08-4821TC-08FJX-08FJX-255 H/A	33	1	616869	04-4511TC-06FJX-06FJX90-225 H/A
16	6	616025	08-4821TC-08FJX-08FJX-50 H/A	34	1	616415	04-4511TC-06FJX-06FJX90-142 H/A
17	22	618119	9/16MJIC-90-9/16MOR LBO	35	1	616864	04-4511TC-06FJX-06FJX90-137 H/A
18	1	611246	04-4821TC-06FJX-06FJX-174 H/A				

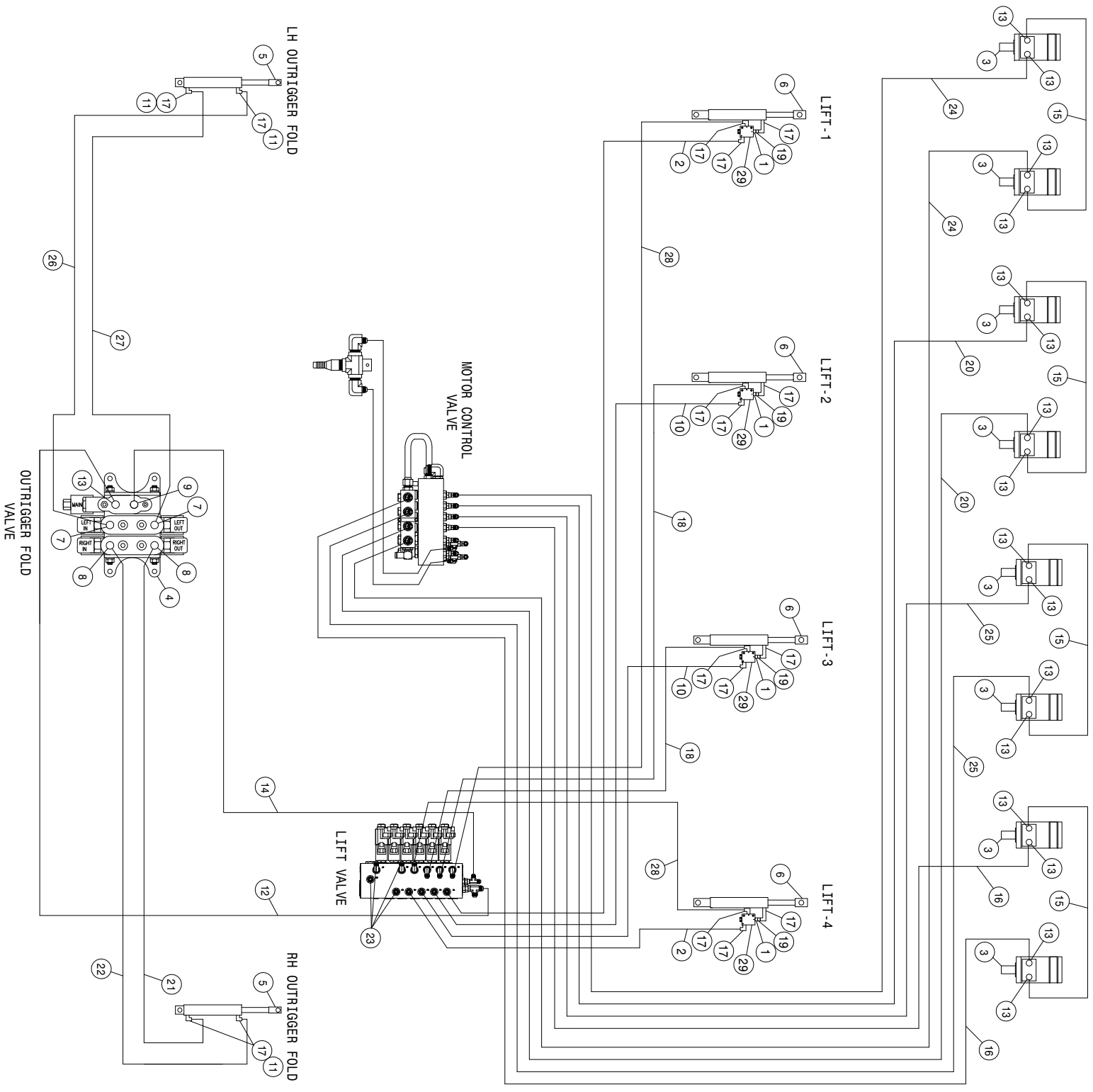

204SP 8R QUAD 4L 20" HYD SCHEM 2011
REFERENCE DRAWING NO. 499074

DET.	QTY	PART NO.	DESCRIPTION	DET.	QTY	PART NO.	DESCRIPTION
1	4	618668	9/16FJIC SWIV-9/16MOR ADPTR	16	2	614690	08-482TC-08FJX-08FJX-192
2	2	616864	04-451TC-06FJX-06FJX90-137 H/A	17	17	618119	9/16MJIC-90-9/16MOR LBO
3	8	610547	HYD MOTOR 4.5CI 1IN SHFT	18	2	616060	04-482TC-06FJX-06FJX-104
4	1	606090	BRAND HYD VALVE, 2-SECT SER 36	19	4	618733	9/16JIC .042 ORIFICE ADPTR
5	2	621520	HYD CYL, 2.00 X 10.00 X 1.000	20	2	614689	08-482TC-08FJX-08FJX-120
6	4	621564	HYD CYL, 2.00 X 11.00 X 1.50 1W	21	1	616025	08-482TC-08FJX-08FJX-50
7	2	618709	9/16MJIC-90-3/4MOR EX LG LBO	22	1	614152	04-482TC-06FJX-06FJX-114
8	2	618115	9/16MJIC-90-3/4MOR LBO	23	4	618531	9/16FJIC CAP NUT
9	1	618310	9/16MJIC-7/8MOR ADPTR	24	2	616423	08-482TC-08FJX-08FJX-163
10	2	616863	04-451TC-06FJX-06FJX90-108 H/A	25	2	616168	08-482TC-08FJX-08FJX-139
11	4	618731	9/16JIC .025 ORIFICE ADPTR	26	1	615727	04-482TC-06FJX-06FJX-75
12	1	616505	08-451TC-08FJX-08FJX90-24	27	1	614077	04-482TC-06FJX-06FJX-88
13	17	618327	3/4MJIC-7/8MOR ADPTR	28	2	614101	04-482TC-06FJX-06FJX-133
14	1	616117	06-451TC-06FJX-06FJX-17	29	4	607565	CHECK VLV,PILOT TO OPEN, SUN
15	4	614373	08-482TC-08FJX-08FJX-44				

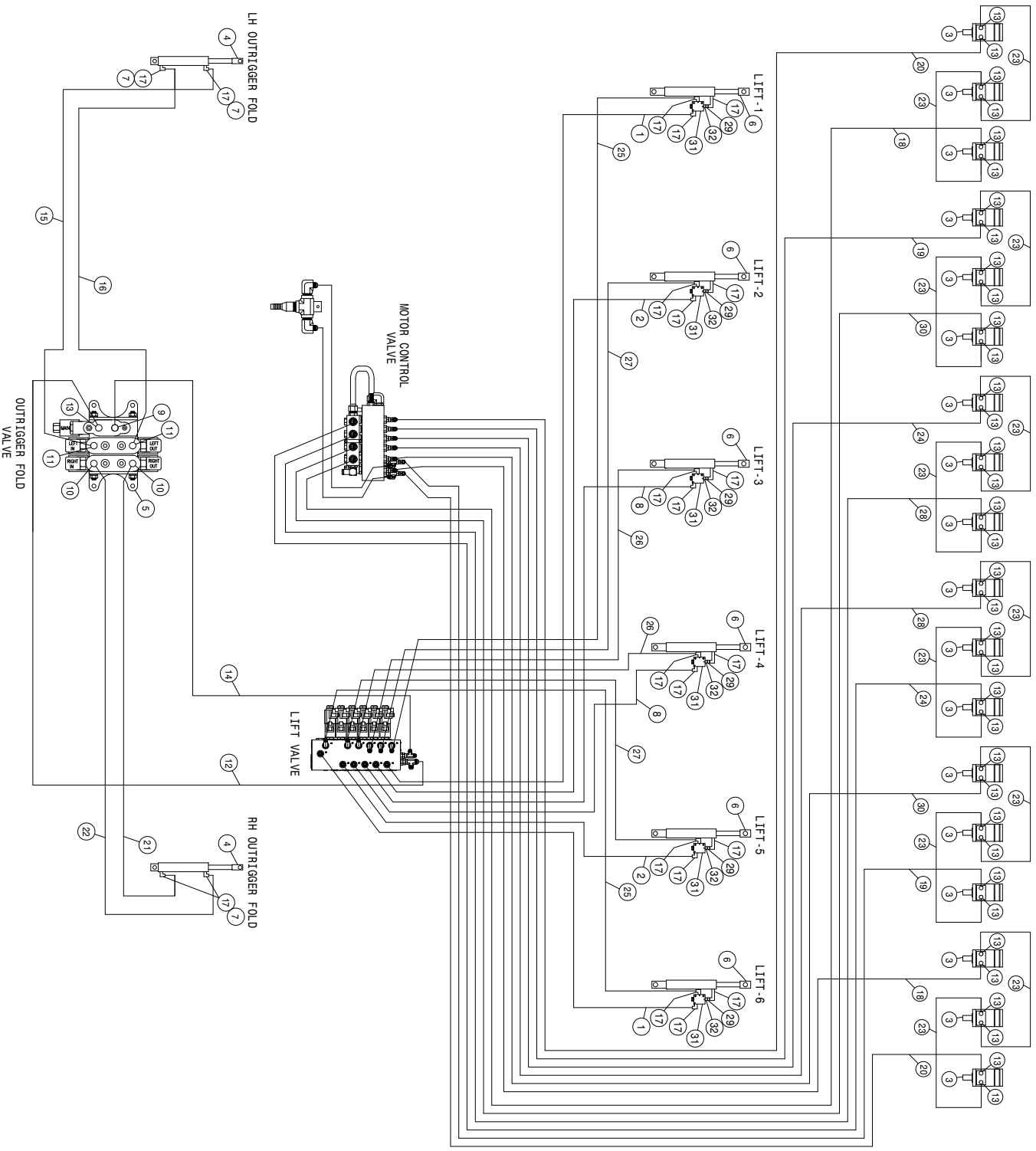

204SP 18R QUAD 20" 6L LS HYD SCHEM 2011
REFERENCE DRAWING NO. 499075

DET.	QTY	PART NO.	DESCRIPTION	DET.	QTY	PART NO.	DESCRIPTION
1	2	616871	04-451TC-06FJX-06FJX90-262 H/A	17	22	618119	9/16MJIC-90-9/16MOR LBO
2	2	616866	04-451TC-06FJX-06FJX90-178 H/A	18	2	614387	08-482TC-08FJX-08FJX-267 H/A
3	18	610547	HYD MOTOR 4.5CI 1IN SHFT	19	2	616223	08-482TC-08FJX-08FJX-232 H/A
4	2	621520	HYD CYL, 2.00 X 10.00 X 1.000	20	2	616170	08-482TC-08FJX-08FJX-295 H/A
5	1	606090	BRAND HYD VALVE, 2-SECT SER 36	21	1	616205	04-482TC-06FJX-06FJX-117 H/A
6	6	621564	HYD CYL, 2.00 X 11.00 X 1.50 1W	22	1	614152	04-482TC-06FJX-06FJX-114 H/A
7	4	618731	9/16JIC .025 ORIFICE ADPTR	23	12	614373	08-482TC-08FJX-08FJX-44 H/A
8	2	616863	04-451TC-06FJX-06FJX90-108 H/A	24	2	616169	08-482TC-08FJX-08FJX-146 H/A
9	1	618310	9/16MJIC-7/8MOR ADPTR	25	2	614377	04-482TC-06FJX-06FJX-258 H/A
10	2	618115	9/16MJIC-90-3/4MOR LBO	26	2	616060	04-482TC-06FJX-06FJX-104 H/A
11	2	618709	9/16MJIC-90-3/4MOR EX LG LBO	27	2	611246	04-482TC-06FJX-06FJX-174 H/A
12	1	616505	08-451TC-08FJX-08FJX90-24 H/A	28	2	614689	08-482TC-08FJX-08FJX-120 H/A
13	37	618327	3/4MJIC-7/8MOR ADPTR	29	6	618733	9/16JIC .042 ORIFICE ADPTR
14	1	616117	06-451TC-06FJX-06FJX-17 H/A	30	2	614378	08-482TC-08FJX-08FJX-207 H/A
15	1	615727	04-482TC-06FJX-06FJX-75 H/A	31	6	607565	CHECK VLV, PILOT TO OPEN, SUN
16	1	614077	04-482TC-06FJX-06FJX-88 H/A	32	6	618668	9/16FJIC SWIV-9/16MOR ADPTR

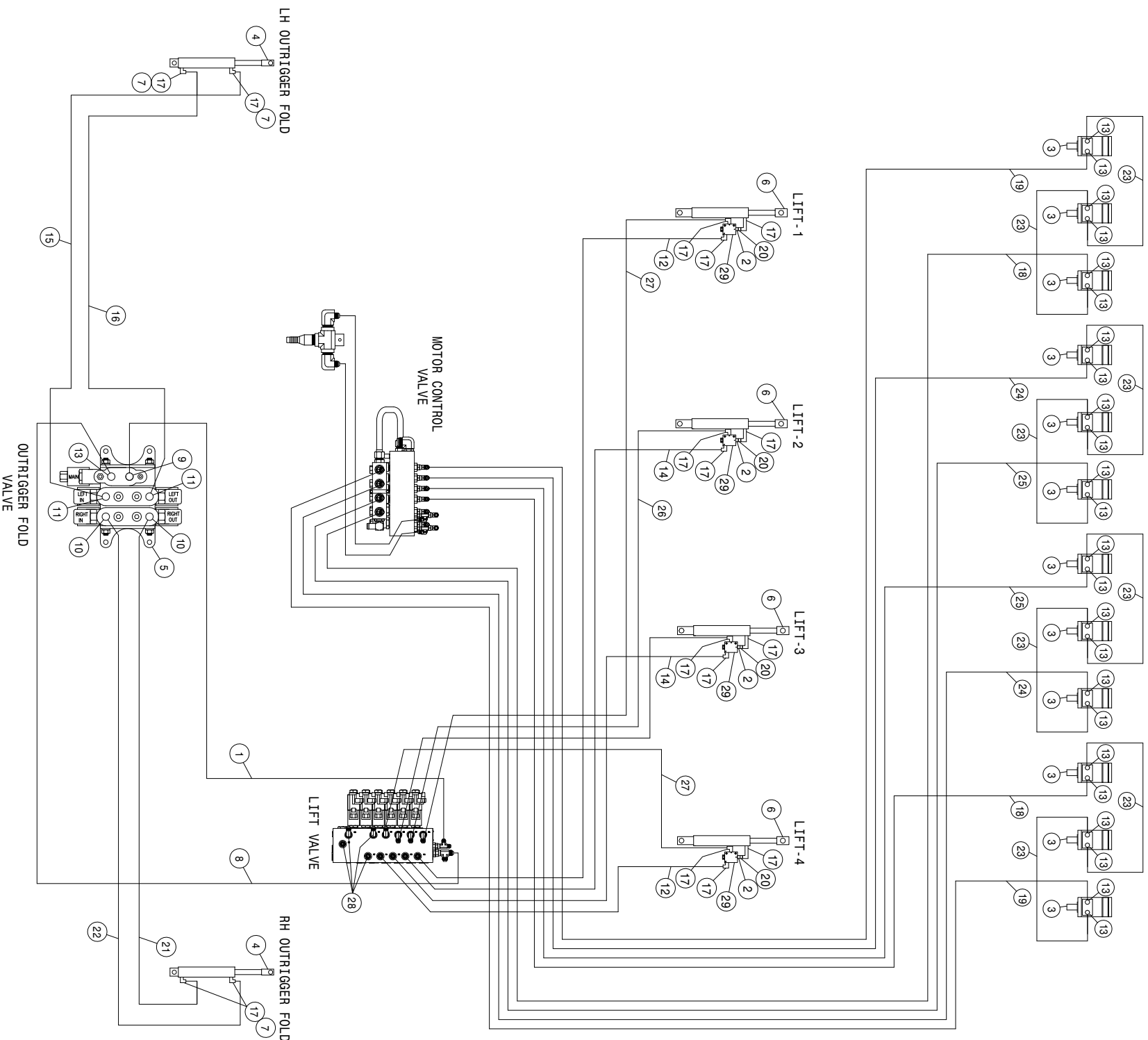

204SP 12R QUAD 52CM 4L LS HYD SHEM 2011
REFERENCE DRAWING NO. 499085

DET.	QTY	PART NO.	DESCRIPTION	DET.	QTY	PART NO.	DESCRIPTION
1	1	616117	06-451TC-06FJX-06FJX-17 H/A	16	1	614077	04-482TC-06FJX-06FJX-88 H/A
2	4	618668	9/16FJIC SWIV-9/16MOR ADPTR	17	16	618119	9/16MJIC-90-9/16MOR LBO
3	12	610547	HYD MOTOR 4.5CI 1IN SHFT	18	2	614378	08-482TC-08FJX-08FJX-207 H/A
4	2	621520	HYD CYL, 2.00 X 10.00 X 1.000	19	2	616223	08-482TC-08FJX-08FJX-232 H/A
5	1	606090	BRAND HYD VALVE, 2-SECT SER 36	20	4	618733	9/16JIC .042 ORIFICE ADPTR
6	4	621564	HYD CYL,2.00 X 11.00 X 1.50 1W	21	1	616205	04-482TC-06FJX-06FJX-117 H/A
7	4	618731	9/16JIC .025 ORIFICE ADPTR	22	1	614152	04-482TC-06FJX-06FJX-114 H/A
8	1	616505	08-451TC-08FJX-08FJX90-24 H/A	23	8	614373	08-482TC-08FJX-08FJX-44 H/A
9	1	618310	9/16MJIC-7/8MOR ADPTR	24	2	616169	08-482TC-08FJX-08FJX-146 H/A
10	2	618115	9/16MJIC-90-3/4MOR LBO	25	2	614689	08-482TC-08FJX-08FJX-120 H/A
11	2	618709	9/16MJIC-90-3/4MOR EX LG LBO	26	2	616060	04-482TC-06FJX-06FJX-104 H/A
12	2	616866	04-451TC-06FJX-06FJX90-178 H/A	27	2	611246	04-482TC-06FJX-06FJX-174 H/A
13	25	618327	3/4MJIC-7/8MOR ADPTR	28	4	618531	9/16FJIC CAP NUT
14	2	616863	04-451TC-06FJX-06FJX90-108 H/A	29	4	607565	CHECK VLV,PILOT TO OPEN, SUN
15	1	615727	04-482TC-06FJX-06FJX-75 H/A				

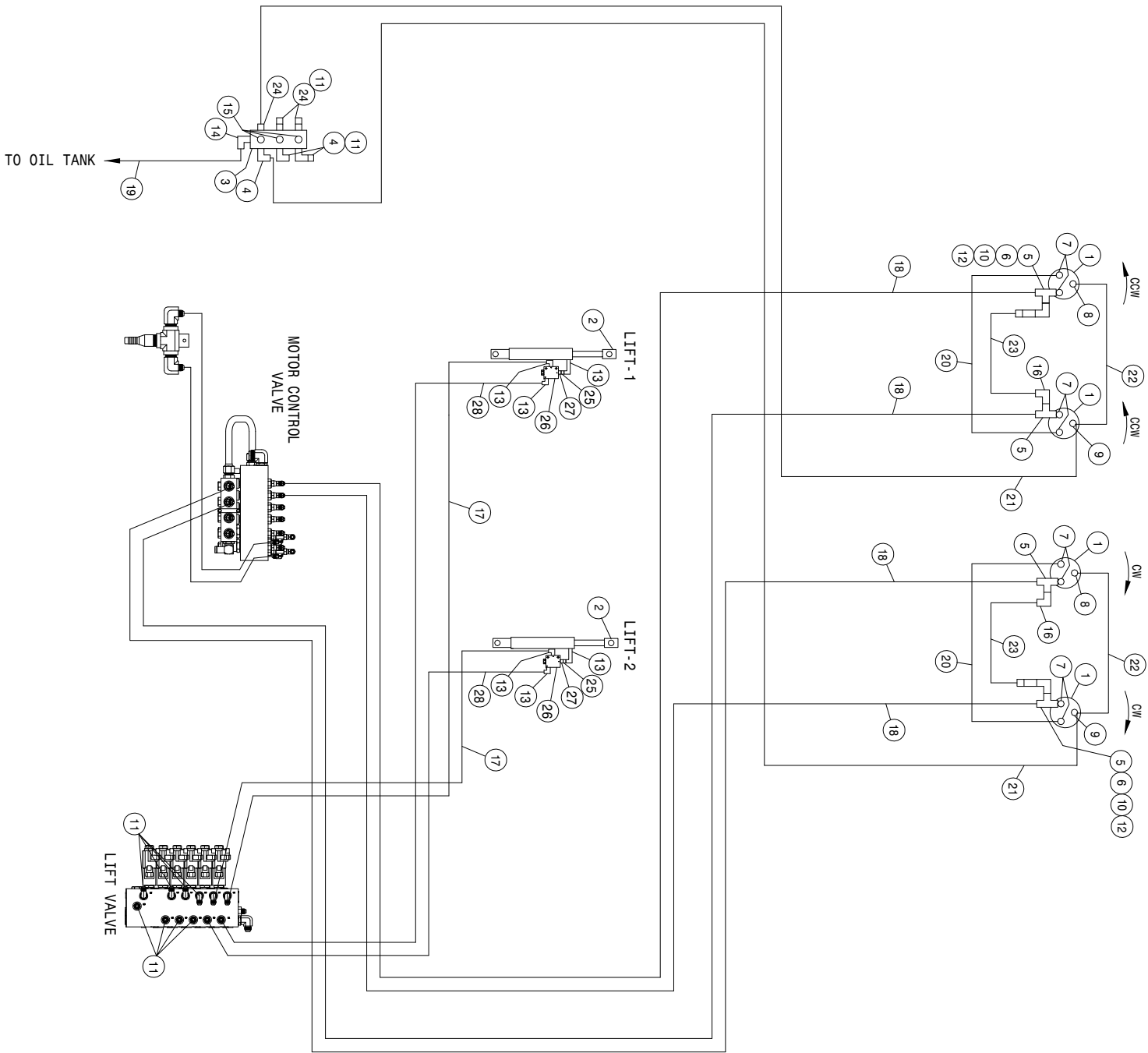

204 4R CUTTER 2L LS HYD SCHEM 2011
REFERENCE DRAWING NO. 499076

DET.	QTY	PART NO.	DESCRIPTION	DET.	QTY	PART NO.	DESCRIPTION
1	4	610755	BARNES HYD MOTOR, D-SERIES 01	15	3	611159	3/4MOR PLUG, HEX HEAD
2	2	621564	HYD CYL,2.00 X 11.00 X 1.50 1M	16	2	618609	3/4MJIC-90-3/4FJIC SWIV LBO
3	1	606021	HYD RETURN MANIF. 3/4FOR, 9-PORT	17	2	615729	04-482TC-06FJX-06FJX-84
4	3	618115	9/16MJIC-90-3/4MOR LBO	18	4	616168	08-482TC-08FJX-08FJX-139
5	4	618451	3/4FJIC SW RUN TEE-3/4MJIC	19	1	601555	HOSE, 3/4 X 150 1FBR-1SPI
6	2	618620	3/4FJX-90-1/2MNPT ADPTR	20	2	614368	08-482TC-08FJX-08FJX-60
7	8	611125	3/4MJIC-3/4MOR ADPTR	21	2	611202	04-482TC-06FJX-06FJX-136
8	2	618530	9/16MJIC-1/8MNPT ADPTR	22	2	616422	04-482TC-06FJX-06FJX90-50
9	2	618546	1/8MNPT RUN TEE-9/16MJIC	23	2	616025	08-482TC-08FJX-08FJX-50
10	2	690338	LINE CHECK VALVE HYD .50NPT	24	1	618109	9/16MJIC-3/4MOR ADPTR
11	12	618531	9/16FJIC CAP NUT	25	2	618733	9/16JIC .042 ORIFICE ADPTR
12	2	611147	3/4MJIC-1/2MNPT ADPTR	26	2	607565	CHECK VLV, PILOT TO OPEN, SUN
13	6	618119	9/16MJIC-90-9/16MOR LBO	27	2	618668	9/16FJIC SWIV-9/16MOR ADPTR
14	1	618118	3/4 HOSE BARB-90-1 1/16MOR	28	2	616861	04-451TC-06FJX-06FJX90-88

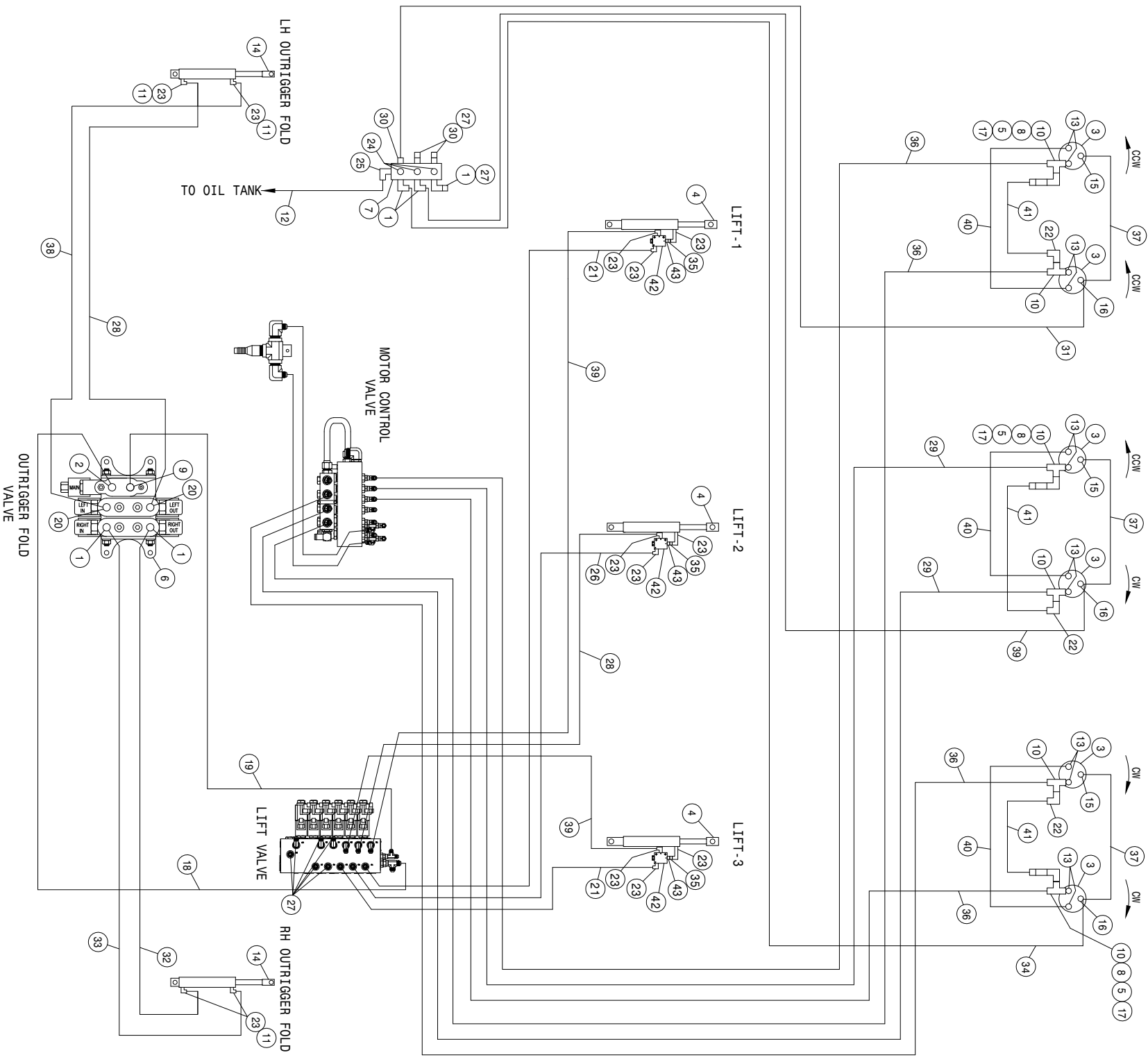

204SP 6R CUTTER 3L LS HYD SCHEM 2011
REFERENCE DRAWING NO. 499077

DET.	QTY	PART NO.	DESCRIPTION	DET.	QTY	PART NO.	DESCRIPTION
1	5	618115	9/16MJIC-90-3/4MOR LBO	23	13	618119	9/16MJIC-90-9/16MOR LBO
2	1	618327	3/4MJIC-7/8MOR ADPTR	24	3	611159	3/4MOR PLUG, HEX HEAD
3	6	610755	BARNES HYD MOTOR, D-SERIES 01	25	1	618118	3/4 HOSE BARB-90-1 1/16MOR
4	3	621564	HYD CYL, 2.00 X 11.00 X 1.50 1W	26	1	616862	04-451TC-06FJX-06FJX90-92
5	3	690338	LINE CHECK VALVE HYD .50NPT	27	9	618531	9/16FJIC CAP NUT
6	1	606090	BRAND HYD VALVE, 2-SECT SER 36	28	2	614077	04-482TC-06FJX-06FJX-88
7	1	606021	HYD RETURN MANIF, 3/4FOR, 9-PORT	29	2	614688	08-482TC-08FJX-08FJX-108
8	3	618620	3/4FJX-90-1/2MNPT ADPTR	30	3	618109	9/16MJIC-3/4MOR ADPTR
9	1	618310	9/16MJIC-7/8MOR ADPTR	31	1	614102	04-482TC-06FJX-06FJX-191
10	6	618451	3/4FJIC SW RUN TEE-3/4MJIC	32	1	616205	04-482TC-06FJX-06FJX-117
11	4	618731	9/16JIC .025 ORIFICE ADPTR	33	2	614152	04-482TC-06FJX-06FJX-114
12	1	601555	HOSE, 3/4 X 150 1FBR-1SPI	34	1	611210	04-482TC-06FJX-06FJX-156
13	12	611125	3/4MJIC-3/4MOR ADPTR	35	3	618733	9/16JIC .042 ORIFICE ADPTR
14	2	621520	HYD CYL, 2.00 X 10.00 X 1.000	36	4	614690	08-482TC-08FJX-08FJX-192
15	3	618530	9/16MJIC-1/8MNPT ADPTR	37	3	616422	04-482TC-06FJX-06FJX90-50
16	3	618546	1/8MNPT RUN TEE-9/16MJIC	38	1	615727	04-482TC-06FJX-06FJX-75
17	3	611147	3/4MJIC-1/2MNPT ADPTR	39	2	614101	04-482TC-06FJX-06FJX-133
18	1	616505	08-451TC-08FJX-08FJX90-24	40	3	614368	08-482TC-08FJX-08FJX-60
19	1	616117	06-451TC-06FJX-06FJX-17	41	3	616025	08-482TC-08FJX-08FJX-50
20	2	618709	9/16MJIC-90-3/4MOR EX LG LBO	42	3	607565	CHECK VLV, PILOT TO OPEN, SUN
21	2	616864	04-451TC-06FJX-06FJX90-137	43	3	618668	9/16FJIC SWIV-9/16MOR ADPTR
22	3	618609	3/4MJIC-90-3/4FJIC SWIV LBO				

204SP 8R CUTTER 4L LS HYD SCHEM 2011
 REFERENCE DRAWING NO. 499078

DET.	QTY	PART NO.	DESCRIPTION	DET.	QTY	PART NO.	DESCRIPTION
1	5	618115	9/16MJIC-90-3/4MOR LBO	23	1	618118	3/4 HOSE BARR-90-1 1/16MOR
2	1	618327	3/4MJIC-7/8MOR ADPTR	24	3	611159	3/4MOR PLUG, HEX HEAD
3	8	610755	BARNES HYD MOTOR, D-SERIES 01	25	4	618609	3/4MJIC-90-3/4FJIC SWIV LBO
4	4	621564	HYD CYL, 2.00 X 11.00 X 1.50 1W	26	2	615729	04-482TC-06FJX-06FJX-84 H/A
5	2	621520	HYD CYL, 2.00 X 10.00 X 1.000	27	2	616861	04-451TC-06FJX-06FJX90-88 H/A
6	1	606090	BRAND HYD VALVE, 2-SECT SER 36	28	4	616168	08-482TC-08FJX-08FJX-139 H/A
7	1	606021	HYD RETURN MANIF, 3/4FOR, 9-PORT	29	1	601555	HOSE, 3/4 X 150 1FBR-1SPI
8	8	618451	3/4FJIC SW RUN TEE-3/4MJIC	30	4	614368	08-482TC-08FJX-08FJX-60 H/A
9	1	618310	9/16MJIC-7/8MOR ADPTR	31	1	616205	04-482TC-06FJX-06FJX-117 H/A
10	4	618731	9/16JIC .025 ORIFICE ADPTR	32	1	614152	04-482TC-06FJX-06FJX-114 H/A
11	4	618620	3/4FJX-90-1/2MNPT ADPTR	33	1	614077	04-482TC-06FJX-06FJX-88 H/A
12	1	616505	08-451TC-08FJX-08FJX90-24 H/A	34	4	618733	9/16JIC .042 ORIFICE ADPTR
13	16	611125	3/4MJIC-3/4MOR ADPTR	35	2	614303	04-482TC-06FJX-06FJX-234 H/A
14	2	618709	9/16MJIC-90-3/4MOR EX LG LBO	36	2	611202	04-482TC-06FJX-06FJX-136 H/A
15	4	618530	9/16MJIC-1/8MNPT ADPTR	37	4	614384	08-482TC-08FJX-08FJX-237 H/A
16	4	618546	1/8MNPT RUN TEE-9/16MJIC	38	4	616422	04-482TC-06FJX-06FJX90-50 H/A
17	4	690338	LINE CHECK VALVE HYD .50NPT	39	1	615727	04-482TC-06FJX-06FJX-75 H/A
18	6	618531	9/16FJIC CAP NUT	40	2	611262	04-482TC-06FJX-06FJX-182 H/A
19	1	616117	06-451TC-06FJX-06FJX-17 H/A	41	4	616025	08-482TC-08FJX-08FJX-50 H/A
20	4	611147	3/4MJIC-1/2MNPT ADPTR	42	3	618109	9/16MJIC-3/4MOR ADPTR
21	2	616867	04-451TC-06FJX-06FJX90-186 H/A	43	4	607565	CHECK VLV, PILOT TO OPEN, SUN
22	16	618119	9/16MJIC-90-9/16MOR LBO	44	4	618668	9/16FJIC SWIV-9/16MOR ADPTR

204SP 10R CUTR 4L LS HYD SCHEM 2011
REFERENCE DRAWING NO. 499079

DET.	QTY	PART NO.	DESCRIPTION	DET.	QTY	PART NO.	DESCRIPTION
1	4	618620	3/4FJIC-90-1/2MNPT ADPTR	24	4	611147	3/4MJIC-1/2MNPT ADPTR
2	1	618327	3/4MJIC-7/8MOR ADPTR	25	3	611159	3/4MOR PLUG, HEX HEAD
3	10	610755	BARNES HYD MOTOR, D-SERIES 01	26	1	618118	3/4 HOSE BARB-90-1 1/16MOR
4	4	621564	HYD CYL,2.00 X 11.00 X 1.50 1W	27	3	618109	9/16MJIC-3/4MOR ADPTR
5	2	621520	HYD CYL, 2.00 X 10.00 X 1.000	28	3	616025	08-482TC-08FJX-08FJX-50
6	1	606021	HYD RETURN MANIF,3/4FOR,9-PORT	29	1	601555	HOSE, 3/4 X 150 IFBR-1SPI
7	1	606090	BRAND HYD VALVE, 2-SECT SER 36	30	4	618733	9/16JIC .042 ORIFICE ADPTR
8	8	618451	3/4FJIC SW RUN TEE-3/4MJIC	31	1	614152	04-482TC-06FJX-06FJX-114
9	1	618310	9/16MJIC-7/8MOR ADPTR	32	1	614077	04-482TC-06FJX-06FJX-88
10	4	618731	9/16JIC .025 ORIFICE ADPTR	33	6	616422	04-482TC-06FJX-06FJX90-50
11	4	690338	LINE CHECK VALVE HYD .50NPT	34	2	614377	04-482TC-06FJX-06FJX-258
12	1	616505	08-451TC-08FJX-08FJX90-24	35	2	614384	08-482TC-08FJX-08FJX-237
13	20	611125	3/4MJIC-3/4MOR ADPTR	36	2	614387	08-482TC-08FJX-08FJX-267
14	1	616117	06-451TC-06FJX-06FJX-17	37	2	615729	04-482TC-06FJX-06FJX-84
15	5	618115	9/16MJIC-90-3/4MOR LBO	38	1	615727	04-482TC-06FJX-06FJX-75
16	2	616868	04-451TC-06FJX-06FJX90-205	39	4	616168	08-482TC-08FJX-08FJX-139
17	16	618119	9/16MJIC-90-9/16MOR LBO	40	2	616031	08-482TC-08FJX-08FJX-83
18	2	618709	9/16MJIC-90-3/4MOR EX LG LBO	41	2	611202	04-482TC-06FJX-06FJX-136
19	2	616861	04-451TC-06FJX-06FJX90-88	42	2	614098	04-482TC-06FJX-06FJX-201
20	4	618530	9/16MJIC-1/8MNPT ADPTR	43	6	614368	08-482TC-08FJX-08FJX-60
21	4	618609	3/4MJIC-90-3/4FJIC SWIV LBO	44	4	607565	CHECK VLV,PILOT TO OPEN, SUN
22	6	618546	1/8MNPT RUN TEE-9/16MJIC	45	4	618668	9/16FJIC SWIV-9/16MOR ADPTR
23	6	618531	9/16FJIC CAP NUT				

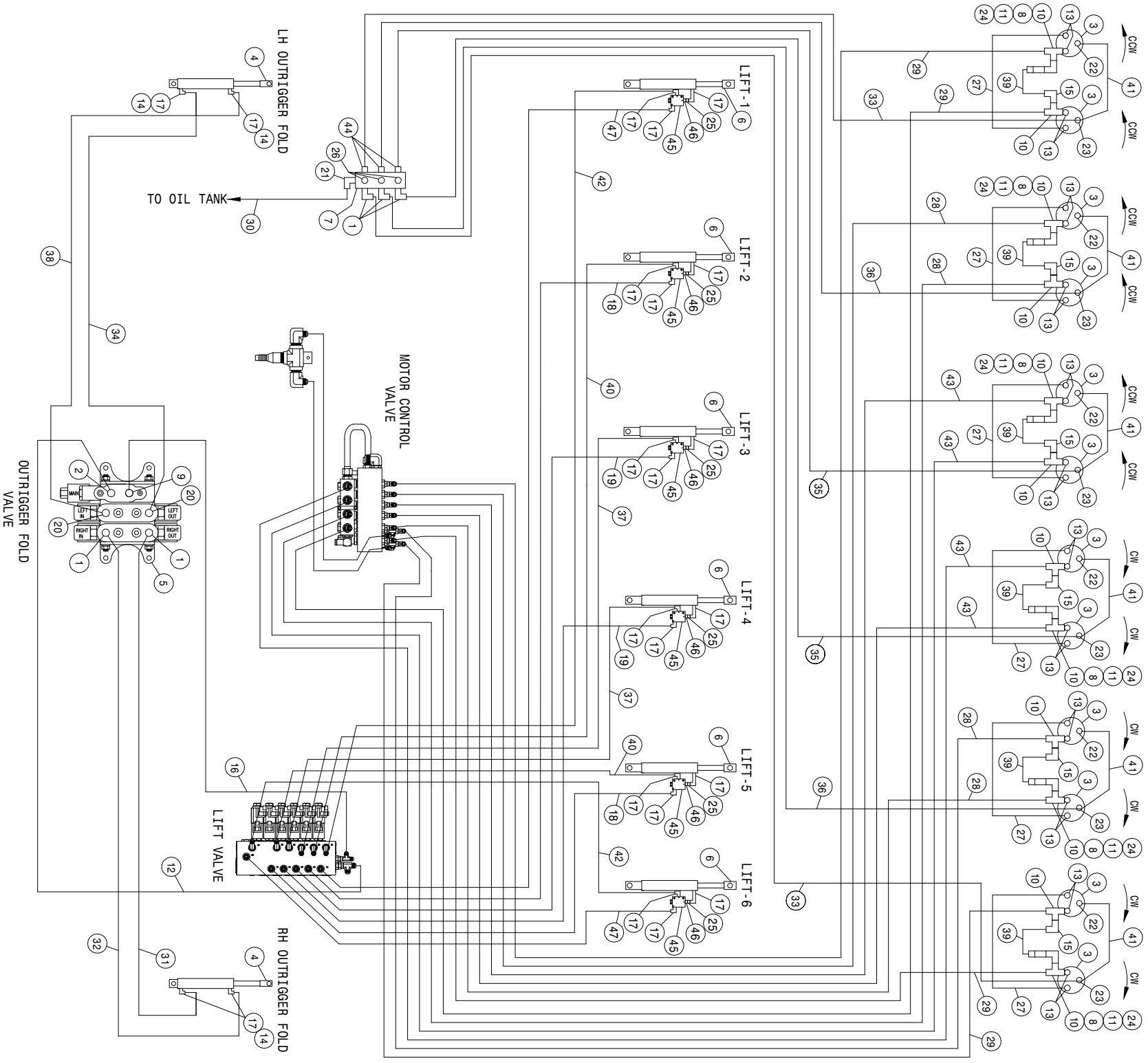

204SP 12R CUTR 6L LS HYD SCHEM 2010
REFERENCE DRAWING NO. 499080

DET.	QTY	PART NO.	DESCRIPTION	DET.	QTY	PART NO.	DESCRIPTION
1	5	618115	9/16MJIC-90-3/4MOR LBO	25	6	618733	9/16JIC .042 ORIFICE ADPTR
2	1	618327	3/4MJIC-7/8MOR ADPTR	26	3	611159	3/4MOR PLUG, HEX HEAD
3	12	610755	BARNES HYD MOTOR, D-SERIES 01	27	6	614368	08-482TC-08FJX-08FJX-60
4	2	621520	HYD CYL, 2.00 X 10.00 X 1.000	28	4	614384	08-482TC-08FJX-08FJX-237
5	1	606090	BRAND HYD VALVE, 2-SECT SER 36	29	4	616170	08-482TC-08FJX-08FJX-295
6	6	621564	HYD CYL, 2.00 X 11.00 X 1.50 1W	30	1	601555	HOSE, 3/4 X 150 1FBR-1SPI
7	1	606021	HYD RETURN MANIF, 3/4FOR, 9-PORT	31	1	616205	04-482TC-06FJX-06FJX-117
8	6	618620	3/4FJX-90-1/2MNPT ADPTR	32	1	614152	04-482TC-06FJX-06FJX-114
9	1	618310	9/16MJIC-7/8MOR ADPTR	33	2	614504	04-482TC-06FJX-06FJX-301
10	12	618451	3/4FJIC SW RUN TEE-3/4MJIC	34	1	614077	04-482TC-06FJX-06FJX-88
11	6	690338	LINE CHECK VALVE HYD .50NPT	35	2	611202	04-482TC-06FJX-06FJX-136
12	1	616505	08-451TC-08FJX-08FJX90-24 H/A	36	2	614303	04-482TC-06FJX-06FJX-234
13	24	611125	3/4MJIC-3/4MOR ADPTR	37	2	615729	04-482TC-06FJX-06FJX-84
14	4	618731	9/16JIC .025 ORIFICE ADPTR	38	1	615727	04-482TC-06FJX-06FJX-75
15	6	618609	3/4MJIC-90-3/4FJIC SWIV LBO	39	6	616025	08-482TC-08FJX-08FJX-50
16	1	616117	06-451TC-06FJX-06FJX-17 H/A	40	2	611262	04-482TC-06FJX-06FJX-182
17	22	618119	9/16MJIC-90-9/16MOR LBO	41	6	616422	04-482TC-06FJX-06FJX90-50
18	2	616867	04-451TC-06FJX-06FJX90-186 H/A	42	2	614377	04-482TC-06FJX-06FJX-258
19	2	616861	04-451TC-06FJX-06FJX90-88 H/A	43	4	616168	08-482TC-08FJX-08FJX-139
20	2	618709	9/16MJIC-90-3/4MOR EX LG LBO	44	3	618109	9/16MJIC-3/4MOR ADPTR
21	1	618118	3/4 HOSE BARB-90-1 1/16MOR	45	6	607565	CHECK VLV, PILOT TO OPEN, SUN
22	6	618530	9/16MJIC-1/8MNPT ADPTR	46	6	618668	9/16FJIC SWIV-9/16MOR ADPTR
23	6	618546	1/8MNPT RUN TEE-9/16MJIC	47	2	616871	04-451TC-06FJX-06FJX90-262 H/A
24	6	611147	3/4MJIC-1/2MNPT ADPTR				

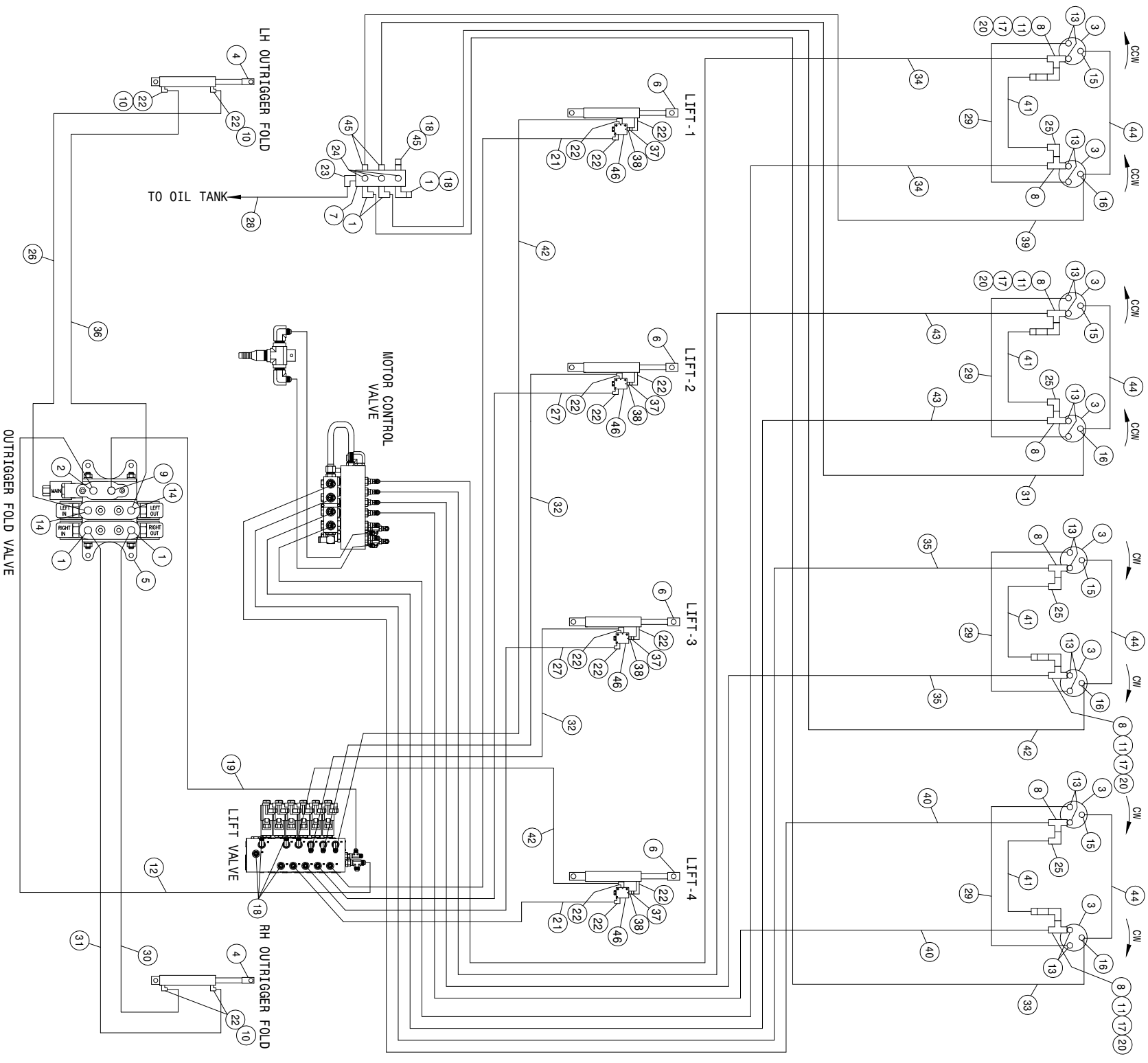

204SP 8R CUTTER 4L 20" HYD SCHEM 2011
REFERENCE DRAWING NO. 499082

DET.	QTY	PART NO.	DESCRIPTION	DET.	QTY	PART NO.	DESCRIPTION
1	5	618115	9/16MJIC-90-3/4MOR LBO	24	3	611159	3/4MOR PLUG, HEX HEAD
2	1	618327	3/4MJIC-7/8MOR ADPTR	25	4	618609	3/4MJIC-90-3/4FJIC SWIV LBO
3	8	610755	BARNES HYD MOTOR, D-SERIES 01	26	1	615727	04-482TC-06FJX-06FJX-75 H/A
4	2	621520	HYD CYL, 2.00 X 10.00 X 1.000	27	2	616863	04-451TC-06FJX-06FJX90-108 H/A
5	1	606090	BRAND HYD VALVE, 2-SECT SER 36	28	1	601555	HOSE, 3/4 X 150 1FBR-1SPI
6	4	621564	HYD CYL, 2.00 X 11.00 X 1.50 1M	29	4	614368	08-482TC-08FJX-08FJX-60 H/A
7	1	606021	HYD RETURN MANIF. 3/4FOR.9-PORT	30	1	616205	04-482TC-06FJX-06FJX-117 H/A
8	8	618451	3/4FJIC SW RUN TEE-3/4MJIC	31	2	614152	04-482TC-06FJX-06FJX-114 H/A
9	1	618310	9/16MJIC-7/8MOR ADPTR	32	2	616060	04-482TC-06FJX-06FJX-104 H/A
10	4	618731	9/16JIC .025 ORIFICE ADPTR	33	1	611246	04-482TC-06FJX-06FJX-174 H/A
11	4	618620	3/4FJX-90-1/2MNPT ADPTR	34	2	616423	08-482TC-08FJX-08FJX-163 H/A
12	1	616505	08-451TC-08FJX-08FJX90-24 H/A	35	2	616168	08-482TC-08FJX-08FJX-139 H/A
13	16	611125	3/4MJIC-3/4MOR ADPTR	36	1	614077	04-482TC-06FJX-06FJX-88 H/A
14	2	618709	9/16MJIC-90-3/4MOR EX LG LBO	37	3	618733	9/16JIC .042 ORIFICE ADPTR
15	4	618530	9/16MJIC-1/8MNPT ADPTR	38	4	618668	9/16FJIC SWIV-9/16MOR ADPTR
16	4	618546	1/8MNPT RUN TEE-9/16MJIC	39	1	611212	04-482TC-06FJX-06FJX-164 H/A
17	4	690338	LINE CHECK VALVE HYD .50NPT	40	2	614690	08-482TC-08FJX-08FJX-192 H/A
18	6	618531	9/16FJIC CAP NUT	41	4	616025	08-482TC-08FJX-08FJX-50 H/A
19	1	616117	06-451TC-06FJX-06FJX-17 H/A	42	3	614101	04-482TC-06FJX-06FJX-133 H/A
20	4	611147	3/4MJIC-1/2MNPT ADPTR	43	2	614689	08-482TC-08FJX-08FJX-120 H/A
21	2	616864	04-451TC-06FJX-06FJX90-137 H/A	44	4	616422	04-482TC-06FJX-06FJX90-50 H/A
22	16	618119	9/16MJIC-90-9/16MOR LBO	45	3	618109	9/16MJIC-3/4MOR ADPTR
23	1	618118	3/4 HOSE BARB-90-1 1/16MOR	46	4	607565	CHECK VLV, PILOT TO OPEN, SUN

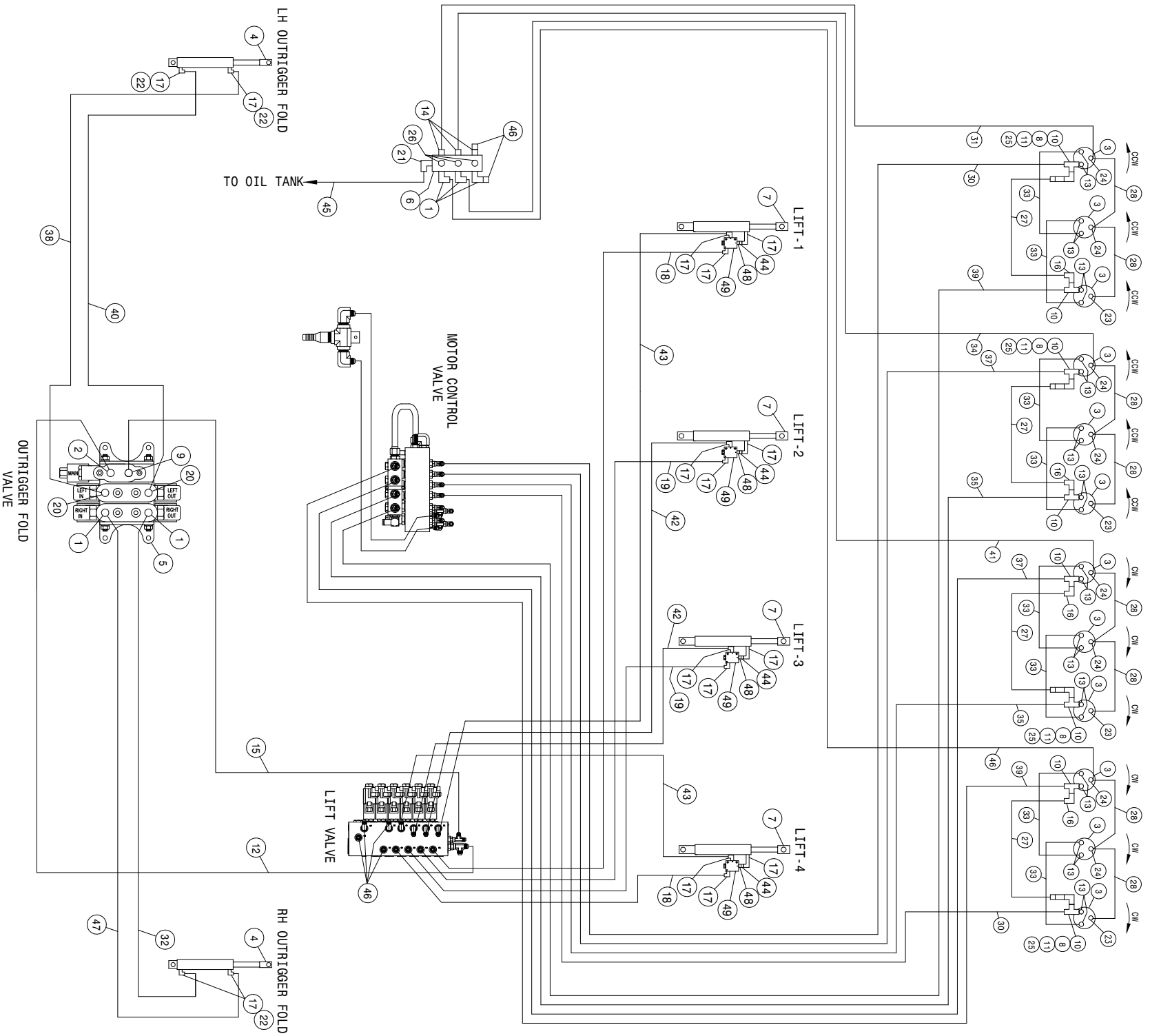

204SP 12R CUTR 20" 4L LS HYD SCHEM 2011
REFERENCE DRAWING NO. 499084

DET.	QTY	PART NO.	DESCRIPTION	DET.	QTY	PART NO.	DESCRIPTION
1	5	618115	9/16MJIC-90-3/4MOR LBO	26	3	611159	3/4MOR PLUG, HEX HEAD
2	1	618327	3/4MJIC-7/8MOR ADPTR	27	4	614662	08-482TC-08FJX-08FJX-72
3	12	610755	BARNES HYD MOTOR, D-SERIES 01	28	8	616422	04-482TC-06FJX-06FJX90-50
4	2	621520	HYD CYL, 2.00 X 10.00 X 1.000	29	1	615729	04-482TC-06FJX-06FJX-84
5	1	606090	BRAND HYD VALVE, 2-SECT SER 36	30	2	616225	08-482TC-08FJX-08FJX-248
6	1	606021	HYD RETURN MANIF, 3/4FOR, 9-PORT	31	1	614577	04-482TC-06FJX-06FJX-258
7	4	621564	HYD CYL, 2.00 X 11.00 X 1.50 1W	32	1	616205	04-482TC-06FJX-06FJX-117
8	4	618620	3/4FJX-90-1/2MNPT ADPTR	33	8	616025	08-482TC-08FJX-08FJX-50
9	1	618310	9/16MJIC-7/8MOR ADPTR	34	1	611262	04-482TC-06FJX-06FJX-182
10	8	618451	3/4FJIC SW RUN TEE-3/4MJIC	35	2	616193	08-482TC-08FJX-08FJX-148
11	4	690338	LINE CHECK VALVE HYD .50NPT	36	1	616421	04-482TC-06FJX-06FJX-228
12	1	616505	08-451TC-08FJX-08FJX90-24 H/A	37	2	614575	08-482TC-08FJX-08FJX-177
13	24	611125	3/4MJIC-3/4MOR ADPTR	38	1	615727	04-482TC-06FJX-06FJX-75
14	3	618109	9/16MJIC-3/4MOR ADPTR	39	2	614691	08-482TC-08FJX-08FJX-220
15	1	616117	06-451TC-06FJX-06FJX-17 H/A	40	1	614077	04-482TC-06FJX-06FJX-88
16	4	618609	3/4MJIC-90-3/4FJIC SWIV LBO	41	1	611212	04-482TC-06FJX-06FJX-164
17	16	618119	9/16MJIC-90-9/16MOR LBO	42	2	611202	04-482TC-06FJX-06FJX-136
18	2	616833	04-451TC-06FJX-06FJX90-194 H/A	43	2	614102	04-482TC-06FJX-06FJX-191
19	2	616865	04-451TC-06FJX-06FJX90-140 H/A	44	4	618733	9/16JIC .042 ORIFICE ADPTR
20	2	618709	9/16MJIC-90-3/4MOR EX LG LBO	45	1	601555	HOSE, 3/4 X 150 1FBR-1SPI
21	1	618118	3/4 HOSE BARB-90-1 1/16MOR	46	6	618531	9/16FJIC CAP NUT
22	4	618731	9/16JIC .025 ORIFICE ADPTR	47	1	614152	04-482TC-06FJX-06FJX-114
23	4	618530	9/16MJIC-1/8MNPT ADPTR	48	4	618668	9/16FJIC SWIV-9/16MOR ADPTR
24	8	618546	1/8MNPT RUN TEE-9/16MJIC	49	4	607565	CHECK VLV, PILOT TO OPEN, SUN
25	4	611147	3/4MJIC-1/2MNPT ADPTR				

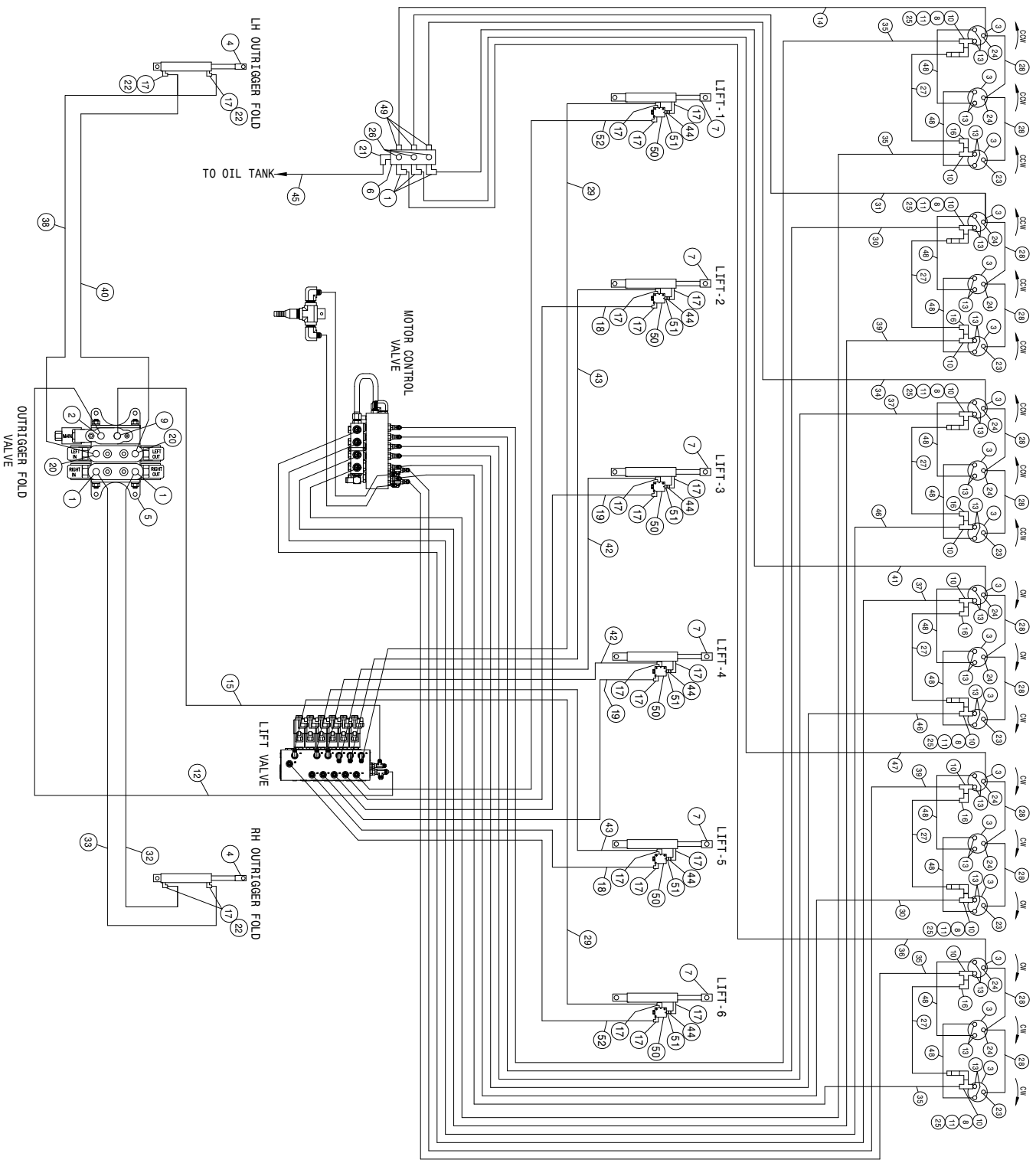

204SP 18R CUTR 20" 6L LS HYD SCHEM 2011
REFERENCE DRAWING NO. 499083

DET.	QTY	PART NO.	DESCRIPTION	DET.	QTY	PART NO.	DESCRIPTION
1	5	618115	9/16MJIC-90-3/4MOR LBO	27	6	614662	08-4822TC-08FJX-08FJX-72
2	1	618327	3/4MJIC-7/8MOR ADPTR	28	12	616422	04-4822TC-06FJX-06FJX90-50
3	18	610755	BARNES HYD MOTOR, D-SERIES 01	29	2	614377	04-4822TC-06FJX-06FJX-258
4	2	621520	HYD CYL, 2.00 X 10.00 X 1.000	30	1	616223	08-4822TC-08FJX-08FJX-232
5	1	606090	BRAND HYD VALVE, 2-SECT SER 36	31	1	614303	04-4822TC-06FJX-06FJX-234
6	1	606021	HYD RETURN MANIF, 3/4FOR, 9-PORT	32	1	616205	04-4822TC-06FJX-06FJX-117
7	6	621564	HYD CYL, 2.00 X 11.00 X 1.50 1W	33	1	614152	04-4822TC-06FJX-06FJX-114
8	6	618620	3/4FJX-90-1/2MNPT ADPTR	34	1	611212	04-4822TC-06FJX-06FJX-164
9	1	618310	9/16MJIC-7/8MOR ADPTR	35	4	614386	08-4822TC-08FJX-08FJX-285
10	12	618451	3/4FJIC SW RUN TEE-3/4MJIC	36	1	615731	04-4822TC-06FJX-06FJX-290
11	6	690338	LINE CHECK VALVE HYD .50NPT	37	2	616169	08-4822TC-08FJX-08FJX-146
12	1	616505	08-451TC-08FJX-08FJX90-24	38	1	615727	04-4822TC-06FJX-06FJX-75
13	36	611125	3/4MJIC-3/4MOR ADPTR	39	2	614378	08-4822TC-08FJX-08FJX-207
14	1	614504	04-4822TC-06FJX-06FJX-301	40	1	614077	04-4822TC-06FJX-06FJX-88
15	1	616117	06-451TC-06FJX-06FJX-17	41	1	614101	04-4822TC-06FJX-06FJX-133
16	6	618609	3/4MJIC-90-3/4FJIC SWIV LBO	42	2	616060	04-4822TC-06FJX-06FJX-104
17	22	618119	9/16MJIC-90-9/16MOR LBO	43	2	611246	04-4822TC-06FJX-06FJX-174
18	2	616866	04-451TC-06FJX-06FJX90-178	44	6	618733	9/16JIC .042 ORIFICE ADPTR
19	2	616863	04-451TC-06FJX-06FJX90-108	45	1	601555	HOSE, 3/4 X 150 1FBR-1SPI
20	2	618709	9/16MJIC-90-3/4MOR EX LG LBO	46	2	614689	08-4822TC-08FJX-08FJX-120
21	1	618118	3/4 HOSE BARB-90-1 1/16MOR	47	1	614100	04-4822TC-06FJX-06FJX-211
22	4	618731	9/16JIC .025 ORIFICE ADPTR	48	12	616025	08-4822TC-08FJX-08FJX-50
23	6	618530	9/16MJIC-1/8MNPT ADPTR	49	3	618109	9/16MJIC-3/4MOR ADPTR
24	12	618546	1/8MNPT RUN TEE-9/16MJIC	50	6	607565	CHECK VLV, PILOT TO OPEN, SUN
25	6	611147	3/4MJIC-1/2MNPT ADPTR	51	6	618668	9/16FJIC SWIV-9/16MOR ADPTR
26	3	611159	3/4MOR PLUG, HEX HEAD	52	2	616871	04-451TC-06FJX-06FJX90-262

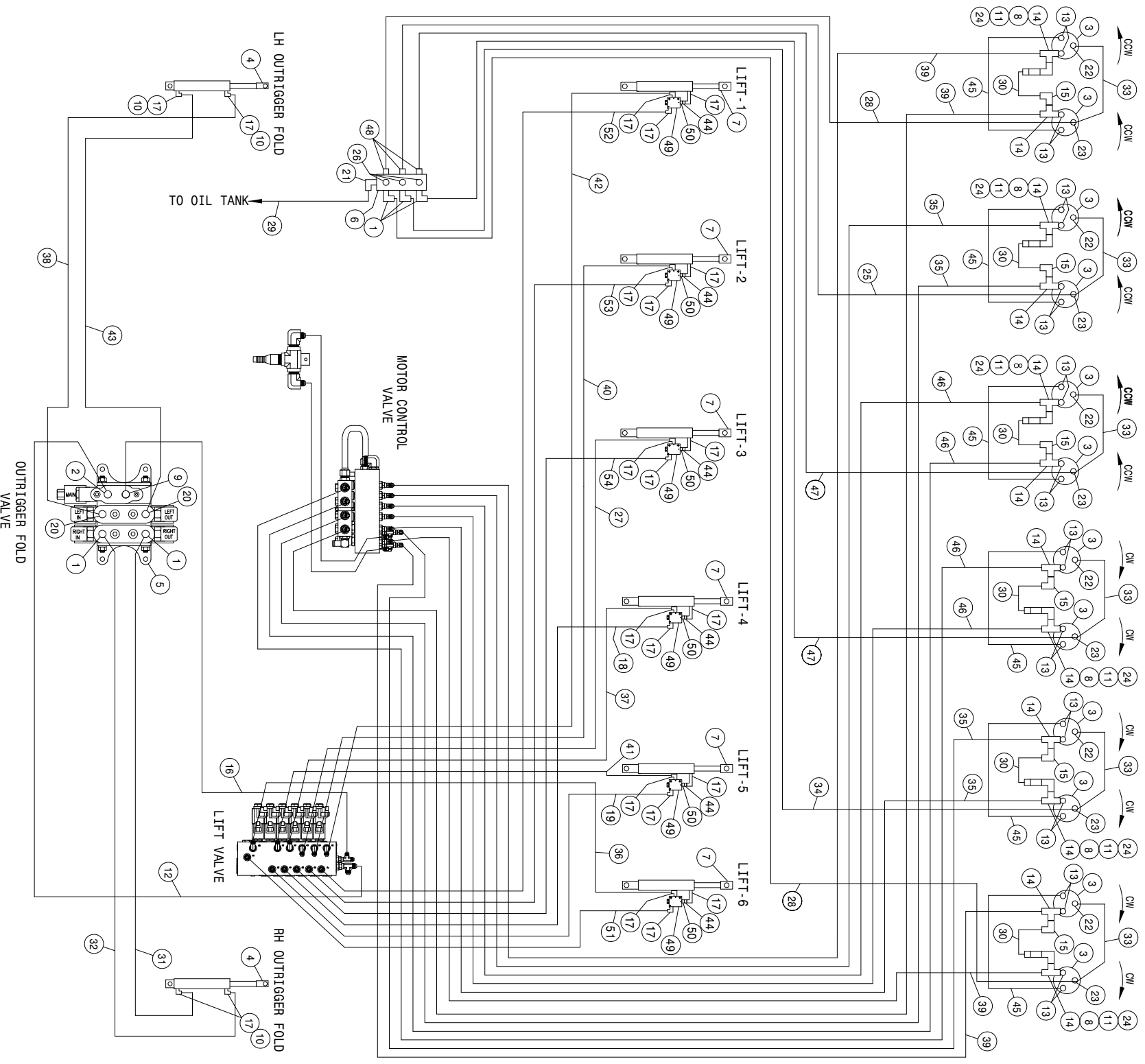

204SP 12R CUTR 52CM 6L LS HYD SCHEM 2011
REFERENCE DRAWING NO. 499081

DET.	QTY	PART NO.	DESCRIPTION	DET.	QTY	PART NO.	DESCRIPTION
1	5	618115	9/16MJIC-90-3/4MOR LBO	28	2	614377	04-482TC-06FJX-06FJX-258
2	1	618327	3/4MJIC-7/8MOR ADPTR	29	1	601555	HOSE, 3/4 X 150 1FBR-1SPI
3	12	610755	BARNES HYD MOTOR, D-SERIES 01	30	6	616025	08-482TC-08FJX-08FJX-50
4	2	621520	HYD CYL, 2.00 X 10.00 X 1.000	31	1	616205	04-482TC-06FJX-06FJX-117
5	1	606090	BRAND HYD VALVE, 2-SECT SER 36	32	1	614152	04-482TC-06FJX-06FJX-114
6	1	606021	HYD RETURN MANIF.3/4FOR.9-PORT	33	6	616422	04-482TC-06FJX-06FJX90-50
7	6	621564	HYD CYL,2.00 X 11.00 X 1.50 1M	34	1	614158	04-482TC-06FJX-06FJX-199
8	6	618620	3/4FJX-90-1/2MNP ADPTR	35	4	614690	08-482TC-08FJX-08FJX-192
9	1	618310	9/16MJIC-7/8MOR ADPTR	36	1	614303	04-482TC-06FJX-06FJX-234
10	4	618731	9/16JIC-.025 ORIFICE ADPTR	37	1	611245	04-482TC-06FJX-06FJX-104
11	6	690338	LINE CHECK VALVE HYD .50NPT	38	1	615727	04-482TC-06FJX-06FJX-75
12	1	616505	08-451TC-08FJX-08FJX90-24	39	4	616227	08-482TC-08FJX-08FJX-255
13	24	611125	3/4MJIC-3/4MOR ADPTR	40	1	616191	04-482TC-06FJX-06FJX-138
14	12	618451	3/4FJIC SW RUN TEE-3/4MJIC	41	1	611246	04-482TC-06FJX-06FJX-174
15	6	618609	3/4MJIC-90-3/4FJIC SWIV LBO	42	1	614154	04-482TC-06FJX-06FJX-221
16	1	616117	06-451TC-06FJX-06FJX-17	43	1	614077	04-482TC-06FJX-06FJX-88
17	22	618119	9/16MJIC-90-9/16MOR LBO	44	6	618733	9/16JIC .042 ORIFICE ADPTR
18	1	616863	04-451TC-06FJX-06FJX90-108	45	6	614368	08-482TC-08FJX-08FJX-60
19	1	616866	04-451TC-06FJX-06FJX90-178	46	4	614689	08-482TC-08FJX-08FJX-120
20	2	618709	9/16MJIC-90-3/4MOR EX LG LBO	47	2	614076	04-482TC-06FJX-06FJX-119
21	1	618118	3/4 HOSE BARB-90-1 1/16MOR	48	3	618109	9/16MJIC-3/4MOR ADPTR
22	6	618530	9/16MJIC-1/8MNP ADPTR	49	6	607505	FLO CONT FC51 0-8 VARI 7/8FOR
23	6	618546	1/8MNP RUN TEE-9/16MJIC	50	6	618668	9/16FJIC SWIV-9/16MOR ADPTR
24	6	611147	3/4MJIC-1/2MNP ADPTR	51	1	616870	04-451TC-06FJX-06FJX90-238
25	1	615095	04-482TC-06FJX-06FJX-194	52	1	616869	04-451TC-06FJX-06FJX90-225
26	3	611159	3/4MOR PLUG, HEX HEAD	53	1	616415	04-451TC-06FJX-06FJX90-142
27	1	614101	04-482TC-06FJX-06FJX-133	54	1	616864	04-451TC-06FJX-06FJX90-137

204SP 12R CUTR 52CM 4L LS HYD SCHEM 2011
REFERENCE DRAWING NO. 499086

DET.	QTY	PART NO.	DESCRIPTION	DET.	QTY	PART NO.	DESCRIPTION
1	5	618115	9/16MJIC-90-3/4MOR LBO	26	3	611159	3/4MOR PLUG, HEX HEAD
2	1	618327	3/4MJIC-7/8MOR ADPTR	27	4	614662	08-482TC-08FJX-08FJX-72
3	12	610755	BARNES HYD MOTOR, D-SERIES 01	28	8	616422	04-482TC-06FJX-06FJX90-50
4	2	621520	HYD CYL, 2.00 X 10.00 X 1.000	29	3	618109	9/16MJIC-3/4MOR ADPTR
5	1	606090	BRAND HYD VALVE, 2-SECT SER 36	30	2	616223	08-482TC-08FJX-08FJX-232
6	1	606021	HYD RETURN MANIF, 3/4FOR, 9-PORT	31	1	614303	04-482TC-06FJX-06FJX-234
7	4	621564	HYD CYL, 2.00 X 11.00 X 1.50 1W	32	1	616205	04-482TC-06FJX-06FJX-117
8	4	618620	3/4FJX-90-1/2MNP ADPTR	33	1	614152	04-482TC-06FJX-06FJX-114
9	1	618310	9/16MJIC-7/8MOR ADPTR	34	1	611212	04-482TC-06FJX-06FJX-164
10	8	618451	3/4FJIC SW RUN TEE-3/4MJIC	35	8	616025	08-482TC-08FJX-08FJX-50
11	4	690338	LINE CHECK VALVE HYD .50NPT	36	1	614100	04-482TC-06FJX-06FJX-211
12	1	616505	08-451TC-08FJX-08FJX90-24 H/A	37	2	616169	08-482TC-08FJX-08FJX-146
13	24	611125	3/4MJIC-3/4MOR ADPTR	38	1	615727	04-482TC-06FJX-06FJX-75
14	2	618531	9/16FJIC CAP NUT	39	2	614378	08-482TC-08FJX-08FJX-207
15	1	616117	06-451TC-06FJX-06FJX-17 H/A	40	1	614077	04-482TC-06FJX-06FJX-88
16	4	618609	3/4MJIC-90-3/4FJIC SWIV LBO	41	1	614101	04-482TC-06FJX-06FJX-133
17	16	618119	9/16MJIC-90-9/16MOR LBO	42	2	616060	04-482TC-06FJX-06FJX-104
18	2	616866	04-451TC-06FJX-06FJX90-178 H/A	43	2	611246	04-482TC-06FJX-06FJX-174
19	2	616863	04-451TC-06FJX-06FJX90-108 H/A	44	4	618733	9/16JIC .042 ORIFICE ADPTR
20	2	618709	9/16MJIC-90-3/4MOR EX LG LBO	45	1	601555	HOSE, 3/4 X 150 1FBR-1SP1
21	1	618118	3/4 HOSE BARB-90-1 1/16MOR	46	2	614689	08-482TC-08FJX-08FJX-120
22	4	618731	9/16JIC .025 ORFICE ADPTR	47	4	618531	9/16FJIC CAP NUT
23	4	618530	9/16MJIC-1/8MNP ADPTR	48	4	607565	CHECK VLV, PILOT TO OPEN, SUN
24	8	618546	1/8MNP RUN TEE-9/16MJIC	49	4	618668	9/16FJIC SWIV-9/16MOR ADPTR
25	4	611147	3/4MJIC-1/2MNP ADPTR				

ABBREVIATIONS

A/C - AIR CONDITIONER	MT - MOUNT
ADPTR - ADAPTER	MTR - MOTOR
AGI - AGITATOR	P/N - PART NUMBER
ALT - ALTERNATOR	PLT - PLATE
ASSY - ASSEMBLY	QTY - QUANTITY
BRKT - BRACKET	RED - REDUCER
DET - DETAIL	REF - REFERENCE
DISPL - DISPLACEMENT	REST - RESTRICTOR
EL - ELBOW	REQ - REQUIRED
EXT - EXTENSION	SHFT - SHAFT
FLO - FLOW	SOL - SOLUTION
FNPT - FEMALE NATIONAL PIPE THREAD	STRG - STEERING
FOR - FEMALE O-RING	ST - STREET
FRT - FRONT	SWIV - SWIVEL
HYD - HYDRAULIC	UNC - UNIFIED NATIONAL COURSE
HYDRO - HYDROSTATIC	UNF - UNIFIED NATIONAL FINE
LG - LONG	V - VOLT
LWR - LOWER	W/ - WITH
MJIC - MALE J.I.C.	WHL - WHEEL
MOR - MALE O-RING	WLD - WELDMENT

INDEX

-A-

ABBREVIATIONS..... 148
 AIR CLEANER..... 12
 BAND..... 12
 CAP..... 12
 CLAMP..... 12
 FILTER..... 12
 HOSE..... 12
 AIR INTAKE SCREEN..... 13
 ALARM, BACKUP..... 36
 ARM,
 SENSOR..... 60
 STEERING..... 14, 15

-B-

BAND, AIR CLEANER..... 12
 BACKUP ALARM..... 36
 BATTERY..... 25
 BOX..... 25
 CABLE..... 25
 HOLD DOWN..... 25
 SWITCH..... 26
 BEACON..... 71, 77
 BELT..... 5
 BLADE,
 CHOPPER..... 65, 66
 CUTTER..... 65, 66
 FAN..... 5
 BLOCK, TERMINAL..... 36
 BOX,
 CONTROL..... 68, 69, 70
 BRAKE
 SOLENOID..... 19
 WEIGHT BRACKET..... 80
 BREATHER..... 22

-C-

CAB..... 71
 CABLE,
 HYDROSTATIC..... 33
 CANOPY..... 77
 CANTRAK..... 34
 CAP,
 AIR CLEANER..... 12
 FUEL..... 23
 RADIATOR..... 13
 STEERING..... 29
 CHOPPER,
 BLADE..... 65, 66
 MALE ROW..... 65, 66
 CIRCUIT BREAKER..... 31

CLAMP,
 MUFFLER..... 4

TEE..... 7
 CONSOLE..... 31
 PANEL..... 30
 CONTROL BOX..... 30
 COVER..... 30
 CUTTER
 BLADE..... 62
 CASE DRAIN..... 62
 HEAD..... 62
 CYLINDER
 FOLD..... 78
 STEERING..... 21

-D-

DECALS..... 82, 83
 DEPTH COMMAND..... 58
 DIAGRAM, WIRING..... 84, 85, 86, 87, 88, 90
 DIFFUSER, SUMP..... 22
 DIPSTICK..... 22
 SENSOR..... 22
 DRINK HOLDER..... 31
 DRIVE ASSEMBLY..... 4
 DUMP VALVE..... 41

-E-

E-STOP..... 33
 ELECTRIC VALVE..... 40
 ENGINE,
 CUMMINS..... 4, 5
 HOOD..... 35
 HOOD PROP..... 35
 EXHAUST PIPE..... 12
 SHIELD..... 35

-F-

FAN BLADE..... 5
 FAN SPACER..... 5
 FILTER
 FUEL..... 4
 OIL..... 5, 9, 22, 39
 FIRE EXTINGUISHER..... 27
 FLASHER
 LIGHT..... 35, 71, 77
 SWITCH..... 29
 FLOW DIVIDER..... 11
 FLOW REGULATOR..... 61
 FLUSHING VALVE..... 8
 FOAM..... 13, 27, 71, 74
 FOLD CYLINDER..... 78
 FOLD VALVE..... 79
 FRONT LEG..... 14, 16

FUEL
 CAP.....23
 GAUGE.....34
 SELECTOR VALVE.....23
 SENDER.....23
 TANK.....23
 FUSE.....30, 68, 69, 70
 HOLDER.....30, 68, 69, 70

-G-
 GAUGE,
 FUEL.....34
 GEAR PUMP.....6

-H-
 HANDRAIL.....24, 25
 HEAD,
 CUTTER.....62
 PULLER.....61
 HEADLIGHT.....71, 77
 HOLD DOWN, BATTERY.....26
 HOLDER,
 DRINK.....36
 MANUAL.....27
 HORN.....36
 SWITCH.....30
 HOSE,
 AIR CLEANER.....12
 RADIATOR.....5
 HYDRAULIC
 MOTOR.....61, 62
 SCHEMATIC.....102
 HYDROSTATIC, LEVER.....32

-I-
 INDICATOR
 LIGHT.....29, 34
 MPH/RPM.....34
 INNER TUBE.....18

-K-
 KIT, LIGHT.....34
 KNOB.....29

-L-
 LADDER.....24, 25
 LEG
 FRONT.....14, 16
 REAR.....16, 17
 SHIM.....14
 SLEEVE, NYLON.....14
 LEVER,
 HYDROSTATIC.....32

LIFTARM.....57, 64
 LIGHT,
 FLASHER.....35, 71, 75
 KIT.....34
 SWITCH.....30
 LS CROSSTUBE.....60
 LS SENSOR.....60

-M-
 MALE ROW CHOPPER.....65, 66
 MANIFOLD, HYDRAULIC.....38
 MANUAL HOLDER.....27
 MOTOR,
 CONTROL VALVE.....37
 MOUNT.....4, 5
 STEERING.....29
 MOUNT,
 RADIATOR.....13
 RUBBER.....4, 27
 MPH/RPM INDICATOR.....34
 MUFFLER.....4
 CLAMP.....4
 MULLION.....35

-N-
 NOISE DEFLECTOR SHIELD.....27

-O-
 OIL
 COOLER.....13
 FILTER.....39
 PRESSURE SENDER.....4
 TANK.....22
 OPERATOR STATION.....27
 OUTRIGGER.....43, 47, 49
 FOLD.....78

-P-
 PHOTO SENSOR.....60
 PIPE, EHAUST.....13
 PIVOT PIN.....43, 47, 49
 PIVOT, STEERING.....20
 PLATFORM, SERVICE.....24, 25
 POSITRACTION VALVE.....7
 PROP ENGINE HOOD.....35
 PULLER
 HEAD.....61
 SHIELD.....61
 PUMGEAR.....6
 SUNDSTRAND.....6

-R-

RADIATOR..... 13
 HOSE.....5
 MOUNT.....13
 SHROUD.....13
 REAR LEG..... 16, 17
 REGULATOR, FLOW..... 61
 RELIEF VALVE..... 11
 RIM..... 18
 ROOF, CANOPY..... 77
 RUBBER..... 71
 BOOT..... 30
 HOOK..... 35
 MOUNT..... 4, 5, 27

-S-

SCHEMATIC,
 HYDRAULIC..... 102
 WIRING..... 90
 SCREEN, AIR INTAKE..... 13
 SEAT..... 28
 SELECTOR VALVE FUEL..... 23
 SENDER,
 FUEL..... 23
 SENSOR,
 LS..... 60
 MPH..... 16
 SERVICE PLATFORM..... 24, 25
 SHEET METAL..... 35, 36
 SHIELD,
 HEAT..... 35
 NOISE DEFLECTOR..... 27
 PULLER..... 61
 WHEEL MOTOR..... 14, 15, 16, 17
 SMV SIGN..... 36
 STABILIZER TUBE..... 45, 47, 49
 STALK GUIDE..... 16, 17
 STEERING,
 ARM..... 14, 15
 CYLINDER..... 21
 MOTOR..... 29
 PIVOT..... 20
 POST..... 29
 WHEEL..... 29
 STRAP, GROUND..... 4
 SUNDSTRAND PUMP..... 6
 SUPPORT POST..... 43, 47, 49
 SWITCH..... 27
 BATTERY..... 26
 BOX..... 68, 69, 70
 FLASHER..... 29
 LIGHT..... 30
 TOGGLE..... 30, 68, 69, 70

-T-

TAILLIGHT..... 36
 TANK,
 FUEL..... 23
 OIL..... 22
 TEE CLAMP..... 7
 TERMINAL BLOCK..... 31
 THROTTLE
 CABLE BRACKET..... 4
 LEVER..... 33
 TIE BAR..... 43, 47, 49
 TIE ROD..... 20
 TIRE..... 18
 PULLER..... 61
 TOGGLE SWITCH..... 30
 TOOLBAR..... 43, 45, 47, 49
 TORQUE HUB..... 14, 15, 16, 17
 TUBE,
 AIR CLEANER..... 12
 INNER..... 18

-V-

VALVE,
 DUMP..... 41
 ELECTRIC..... 40
 FLUSHING..... 8
 FOLD..... 79
 MOTOR CONTROL VALVE..... 37
 POSITRACTION..... 7, 10

-W-

WEIGHT BRACKET..... 80
 WHEELMOTOR..... 14, 15, 16, 17
 WIRING,
 DIAGRAM..... 84, 85, 86, 87
 SCHEMATIC..... 102

Notes: