

PARTS MANUAL
FOR
HAGIE MODEL 204 SP DETASSELER

HAGIE MANUFACTURING COMPANY

BOX 273 CLARION, IOWA 50525 (515) 532-2861

COVERS MACHINE SERIAL NUMBERS: U1010550001 thru U1010550100

06-05 493322
02-08

DETASSELER IDENTIFICATION

Each Hagie detasseler is identified by means of a frame serial number.

This serial number denotes the model, the year in which it was built, and the number of the detasseler. As for further identification, the engine has a serial number, the hydrostatic pump has a serial number, the wheel motors have identification tags, and the planetary hubs have identification plates that describe the type of mount and gear ratio. To insure prompt, efficient service when ordering parts or requesting service repairs from Hagie Manufacturing Company, record the serial and identification numbers in the space provided below.

NOTE: Reference to left hand and right hand used throughout this manual refers to the position when seated in the operator's seat facing forward.

DETASSELER SERIAL NUMBER

ENGINE SERIAL NUMBER

PLANETARY HUB IDENTIFICATION NUMBERS

TABLE OF CONTENTS

ENGINE ASSEMBLIES 4-6

POSITRACTION VALVE. 7

HI-PRESS FILTER & LOOP FLUSHING VALVE 8-9

FLOW DIVIDER. 10-11

EXHAUST PIPE & AIR CLEANER. 12

RADIATOR AND OIL COOLER 13

LEG ASSEMBLIES. 14-21

TIRE. 22

BRAKE SOLENOID ASSEMBLY 23

STEERING CYLINDER ASSEMBLY. 24

TIE ROD ASSEMBLY. 25

FUEL AND OIL TANKS. 26-27

LADDER AND SERVICE PLATFORM 28-29

OPERATOR STATION ASSEMBLY 30-31

INSTRUMENT PANEL ASSEMBLY 32

STEERING POST ASSEMBLY. 33

CONSOLE ASSEMBLY. 34-37

SHEET METAL 38-39

BATTERY 40

RETURN FILTER 41

MOTOR CONTROL VALVE ASSEMBLY. 42-43

ELECTROHYDRAULIC VALVE. 44-47

OUTRIGGER AND LIFT ASSEMBLY 48-58

LIFT CYLINDER ASSEMBLY. 59

QUAD AND CUTTER HEAD. 59-61

MALE ROW CHOPPER. 62-65

DRAIN MANIFOLD ASSEMBLY. 66

CONTROL BOX ASSEMBLY. 67-69

LS SENSOR. 70

DEPTH COMMAND 71-73

CAB OPTION. 74-79

CANOPY OPTION 80-81

WEIGHT BRACKET OPTION 82

OUTRIGGER HYDRAULIC FOLD OPTION 83-84

DECALS. 86-87

WIRING DIAGRAM. 88-95

ELECTRICAL SCHEMATIC. 96-101

HYDRAULIC SCHEMATIC 102-125

ABBREVIATIONS 126

INDEX 127

DIESEL ENGINE ASSEMBLY

DET. QTY PART NO. DESCRIPTION

1	1	290107	GROUND CABLE, 8" X 4GA .406LUGS
2	1	316281	FUEL STRAINER, IN-LINE, DIESEL
3	1	316302	CUMM ENG, 6B5.9A 152@2500
4	1	316252	RH REAR ENG MT WLD, CUMM 94
5	1	316253	LH REAR ENG MT WLD, CUMM 94
6	1	316517	THROTTLE CABLE MT WLD, CUMM 02
7	8	473775	12MM-1.75 X 30MM HEX BOLT
8	10	473784	12MM LOCK WASHER
9	1	316629	THROTTLE CABLE LEVER, CUMM 05
10	2	473826	6MM-1.00 X 16MM HEX BOLT
11	1	193012	QUICKEDGE TRIM .135 TO .250
12	1	800495	SUND DRIVE ASSY, 2.83PILOT 14T
13	12	473792	10MM-1.50 X 30MM HEX BOLT
14	8	473793	10MM-1.50 X 20MM HEX BOLT
15	20	473798	10MM LOCK WASHER
16	4	520120	HOSE CLAMP NO 4 STAINLESS
17	2	311054	RUBBER MOUNT SET, CB-2202-4
18	1	473921	BALL JOINT NO 10-32 THD
19	2	910027	10-32 HEX NUT
20	2	311055	REBOUND WASHER FOR 311054
21	2	473828	12MM-1.50 X 20MM HEX BOLT
22	2	900271	1/2UNC X 3 1/4 HEX BOLT
23	1	903893	10-32 X 1" SLT RD HD MACH SCR
24	2	914008	1/2UNC HEX STOVER NUT
25	1	914027	10-32 HEX STOVER NUT
26	2	920004	1/2 SAE FLAT WASHER
27	2	920510	#10 LOCK WASHER
28	1	316208	FUEL FILTER, PRIMARY CUMM 92
29	1	316209	FUEL FILTER, SECONDARY CUMM92
30	1	504900	PIPE PLUG .75NPT SQ HD
31	1	520055	HOSE CLAMP NO 12 STAINLESS
32	1	601347	HOSE, 3/8 X 10 FUEL LINE
33	1	291674	OIL PRESS SENDER, 125PSI, 1/8NPT
34	1	500900	BLK PIPE ST EL 90DEG .125NPT
35	2	473768	6MM LOCK WASHER
36	1	473804	8MM LOCK WASHER
37	1	473827	8MM-1.25 X 20MM HEX BOLT

*NOTE: DETAIL 31 AND HOSE BARB ARE USED WITH THE CAB OPTION.

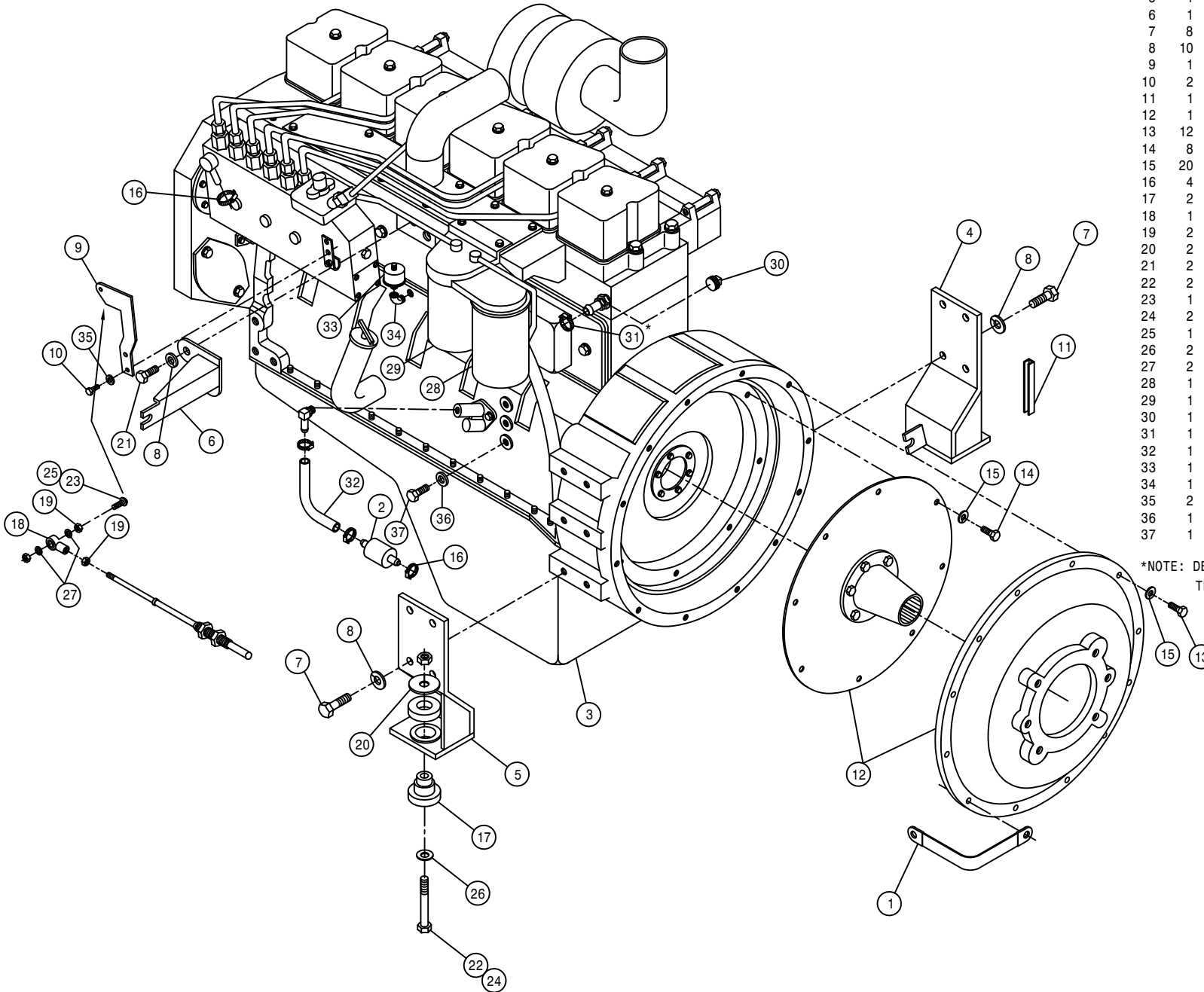

4

DIESEL ENGINE ASSEMBLY

DET. QTY PART NO. DESCRIPTION

1	1	314836	TEMP SENDR 280D 1/2NPT FOR GA	
2	1	316302	CUMM ENG,6B5.9A 152@2500	
3	1	316410	FAN, 22" 6 BLADE 40DEG	
4	1	316250	RH FRT ENG MT WLD, CUMM	94
5	1	316313	LH FRT ENG MT WLD, 284 CUMM	98
6	1	316199	22IN FAN SPACER CUMM	92
7	6	473775	12MM-1.75 X 30MM HEX BOLT	
8	8	473784	12MM LOCK WASHER	
9	4	473804	8MM LOCK WASHER	
10	4	473822	8MM-1.25 X 70MM HEX BOLT	
11	1	316206	POLY V BELT CUMMINS DIESEL	92
12	1	316207	LUBE FILTER CUMMINS DIESEL	92
13	2	311053	RUBBER MOUNT SET,SSB26-1000-1	
14	1	314832	RADIATOR HOSE 1.75 X 19(52423)	
15	1	314886	RADIATOR HOSE 2 1/4 20717	
16	4	900265	1/2UNC X 1 1/2 HEX BOLT	
17	1	193012	QUICKEDGE TRIM .135 TO .250	
18	2	520067	HOSE CLAMP NO 28 STAINLESS	
19	2	520099	HOSE CLAMP NO 40 STAINLESS	
20	2	900271	1/2UNC X 3 1/4 HEX BOLT	
21	6	914008	1/2UNC HEX STOVER NUT	
22	6	920004	1/2 SAE FLAT WASHER	
23	1	341968	TIE PLT 250/280 CUMM	92
24	1	618573	5/8 HOSE BARB-90-1/2MNP	
25	1	520055	HOSE CLAMP NO 12 STAINLESS	
26	1	316339	BREAKER MTG PLT, 2100	98
27	1	316340	BREAKER COVER, 2100	98
28	4	470175	10-32 HEX FLANGE LOCK NUT	
29	2	470216	10-32 X 3/4 FLANGE HEX BOLT	
30	1	470121	1/4UNC HEX FLANGE LOCK NUT	
31	2	473783	12MM-1.75 X 25MM HEX BOLT	
32	1	291197	CIRCUIT BREAKER,30AMP,INLINEMT	
33	4	903812	6-32 X 1/2 SLT RD HD MACH SCR	
34	8	910022	6-32 HEX NUT	
35	1	520126	CUSH HOSE CLAMP 2IN X 5/8W	
36	1	470118	1/4UNC X 3/4 FLANGE HEX BOLT	
37	6	910027	10-32 HEX NUT	
38	1	291556	CIRCUIT BREAKER,50AMP,INLINEMT	
39	1	316367	DELCO ALTERNATOR,130 AMP 22SI	
40	1	291852	RELAY, 40 AMP, VF4 SERIES	
41	1	903883	10-32 X 1/2 SLT RDHD MACH SCR	

*NOTE: DETAIL 24,25,30,35,AND 36 ARE USED WITH THE CAB OPTION.

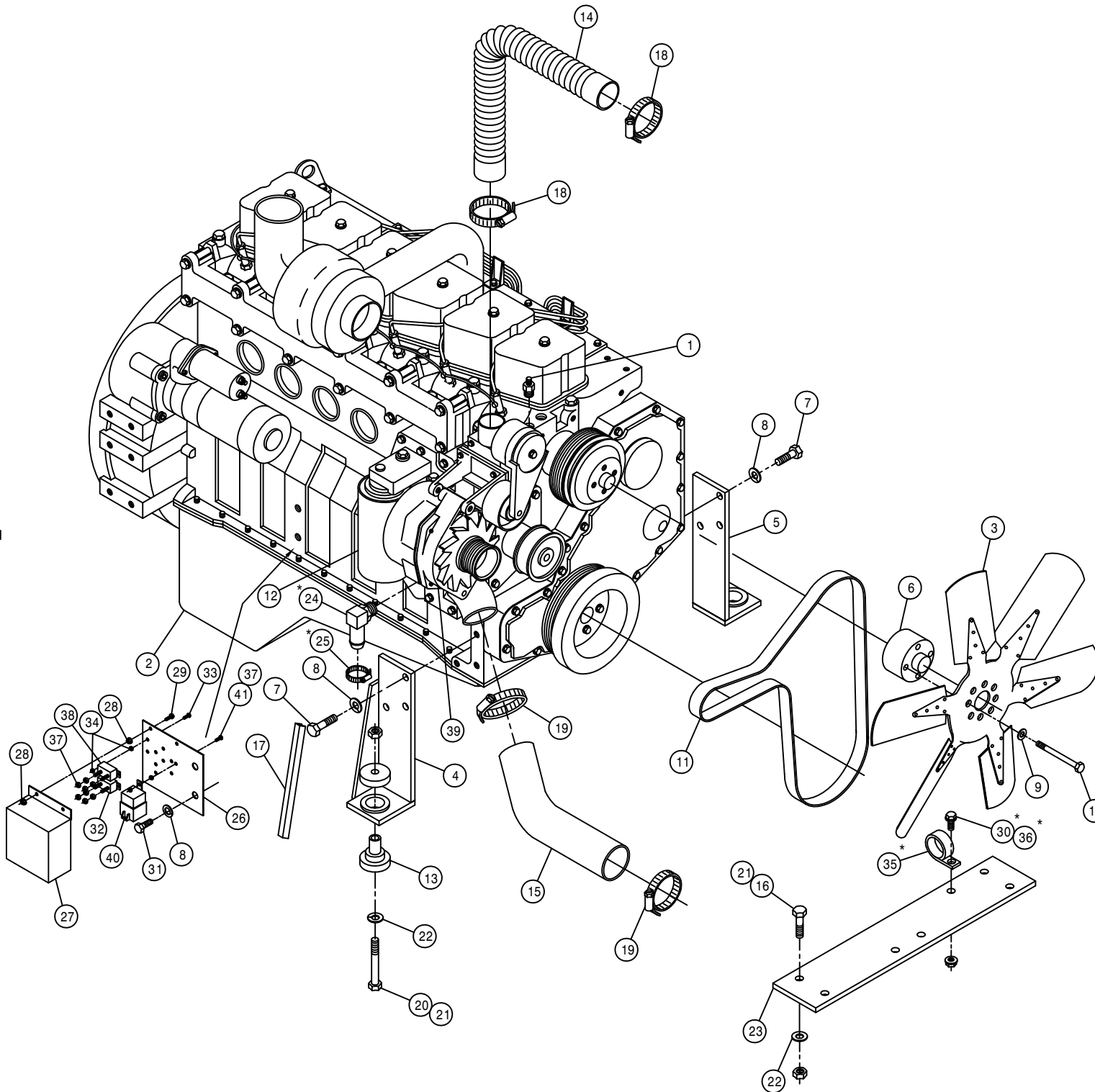

CUMMINS PUMP ASSEMBLY

DET.	QTY	PART NO.	DESCRIPTION
	1	606937	TANDEM PUMP, 606929 & 606938
	1	316160	PUMP CONT LEVER EXT 280 CUMM
	3	470188	7/16-14 X 1 3/4 SKTHD CAP SCR
	4	470189	7/16 HC LOCK WASH FOR 618598
	5	606902	SUND 100CC PUMP,B-MT W/FILT
	6	618118	3/4 HOSE BARB-90-1 1/16MOR
	7	618541	1 5/16FJIC-1 1/16MJIC ADPTR
	8	618638	1IN HOSE BARB-45-1 5/16MOR
	9	618598	1" 4-BOLT FLG X 1 5/16 FOR
	10	618599	1 5/16MOR BRANCH TEE-1 5/16MJ
	11	870219	BUNA ORING 1 5/16 X 1 9/16
	12	900003	1/4UNC X 1" HEX BOLT
	13	2 914000	1/4UNC HEX STOVER NUT
	14	4 920004	1/2 SAE FLAT WASHER
	15	1 473921	BALL JOINT NO 10-32 THD
	16	2 910027	10-32 HEX NUT
	17	1 903893	10-32 X 1" SLT RD HD MACH SCR
	18	1 914027	10-32 HEX STOVER NUT
	19	3 920510	#10 LOCK WASHER
	20	1 606870	O-RING FOR 606865 SUND B-MT
	21	1 505101	BLK PIPE TEE 1.00NPT
	22	1 618639	1 5/8MOR-1 5/16FOR ADPTR
	23	1 505105	1MNPT HEX PIPE NIPPLE STL
	24	1 506005	1 1/4 TO 1 RED BUSH BLK MAL
	25	1 507026	1 1/4MNPT HEX PIPE NIPPLE STL
	26	1 506701	SIDE OUTLET EL 90DEG 1.25NPT
	27	1 601399	HOSE, 3/4 X 13 1FBR-15PI
	28	1 606938	SUND GEAR PUMP,4.00CIR SPLINED
	29	1 606929	SUND GEAR PUMP .66CI, SPLINED
	30	1 611128	7/8MJIC-90-7/8MOR LBO
	31	1 618075	3/4 HOSE BARB-1 1/16MOR
	32	1 618178	1 5/16MJIC-90-1 5/16MOR LBO
	33	1 618596	1 5/8MOR-1 1/4FNPT ADPTR
	34	1 714560	1NPT X 1 HOSE BARB
	35	1 715660	HOSE BARB 1 1/4NPT X 1 1/4
	36	1 716000	3/4 HOSE BARB-90-1MNPT
	37	4 900265	1/2UNC X 1 1/2 HEX BOLT
	38	1 618119	9/16MJIC-90-9/16MOR LBO
	39	1 618183	3/4MJIC-90-7/8MOR LBO
	40	3 520137	1.12/1.25 T-BOLT HOSE CLAMP
	41	1 520132	1.62/1.87 T-BOLT HOSE CLAMP SS
	42	2 520138	1.38/1.56 T-BOLT HOSE CLAMP
	43	2 920002	3/8 SAE FLAT WASHER
	44	2 900130	3/8UNC X 1 1/4 HEX BOLT
	45	1 618327	3/4MJIC-7/8MOR ADPTR
	46	3 618531	9/16FJIC CAP NUT
	47	2 618191	1 1/16MJ-90-1 1/16FJ SWIV LBO
	48	2 618629	9/16MOR BRANCH TEE-9/16MJIC
	49	2 506410	BLK PIPE ST EL 90DEG 1.25NPT

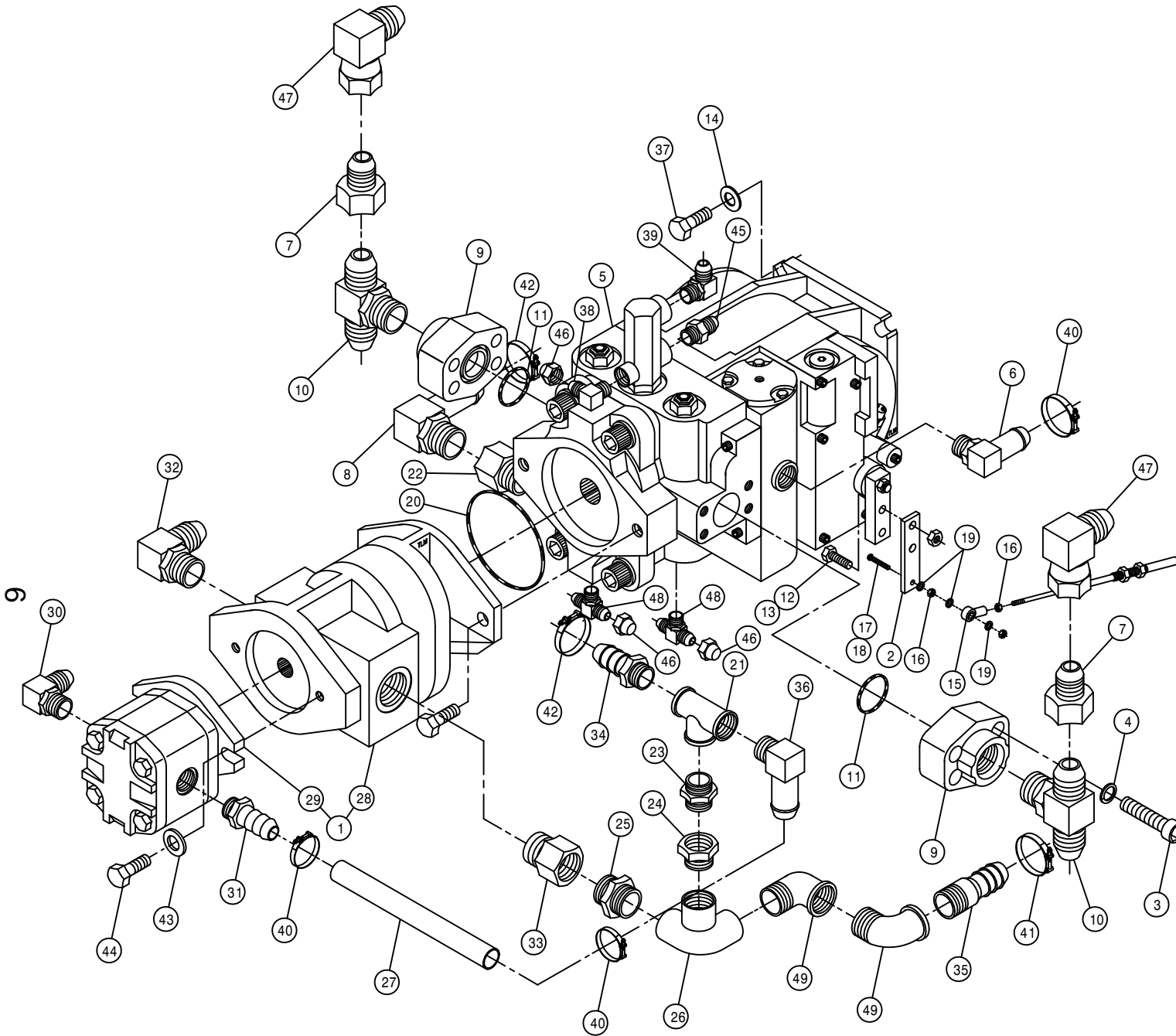

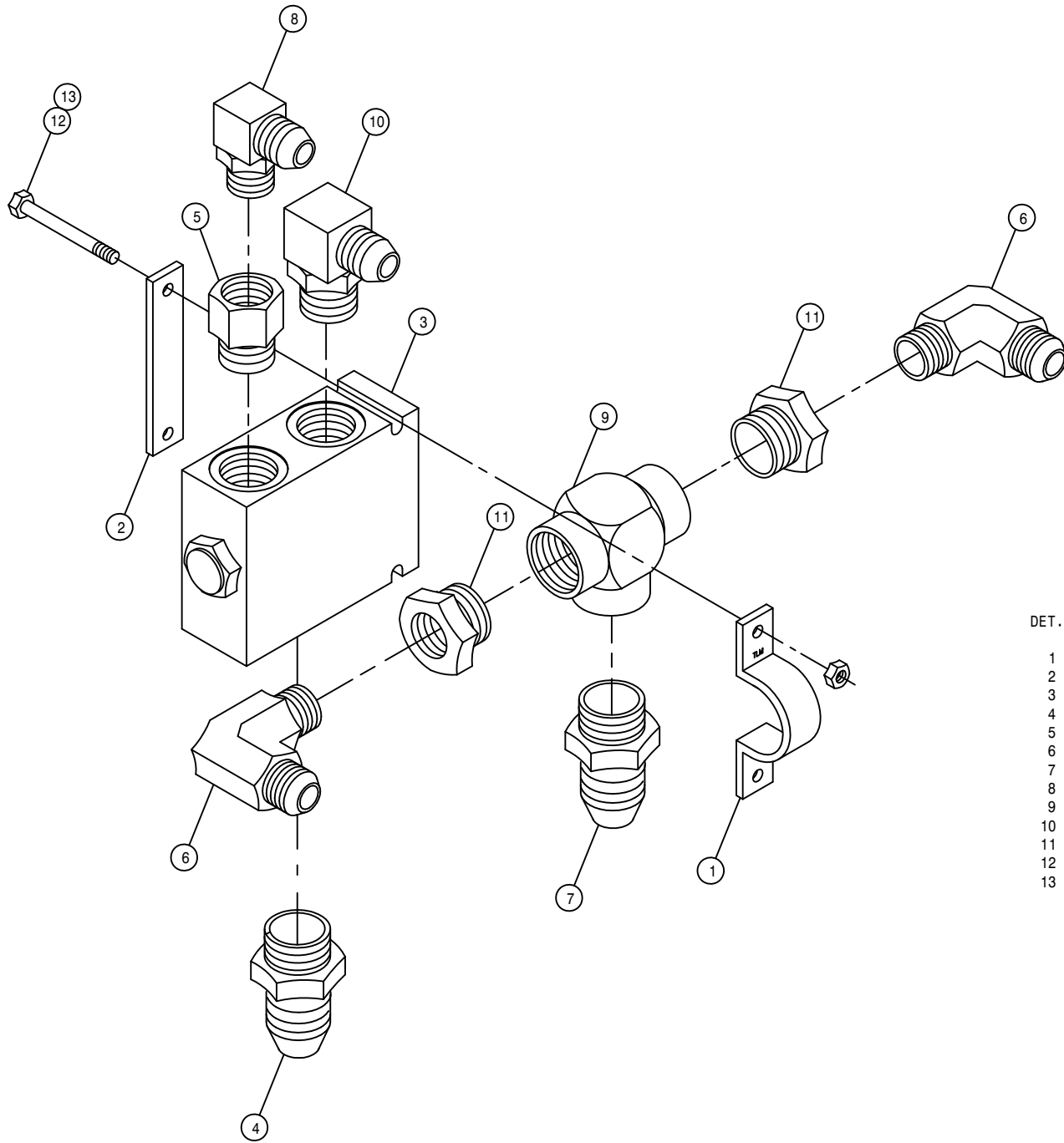

CUMMINS POSITRACTION VALVE ASSEMBLY

DET.	QTY	PART NO.	DESCRIPTION	
1	1	314842	TEE CLAMP, TRAC VLV 200	89
2	1	314843	TEE KEEPER, TRAC VLV 200	89
3	1	610585	POSITRACTION VLV,44SPL	28G
4	1	618308	1 1/16MJIC-1 5/16MOR ADPTR	
5	1	618312	1 5/16MOR-1 1/16FOR ADPTR	
6	2	611124	7/8MJIC-90-1/2MNPT LBO	
7	1	618434	1 1/16MJIC-1MNPT ADPTR	
8	1	618535	7/8MJIC-90-1 1/16MOR LBO	
9	1	618575	1FNPT PIPE TEE STL	
10	1	618589	7/8MJIC-90-1 5/16MOR LBO	
11	2	505005	RED BUSH 1 TO 1/2	
12	2	900011	1/4UNC X 3 1/4 HEX BOLT	
13	2	914000	1/4UNC HEX STOVER NUT	

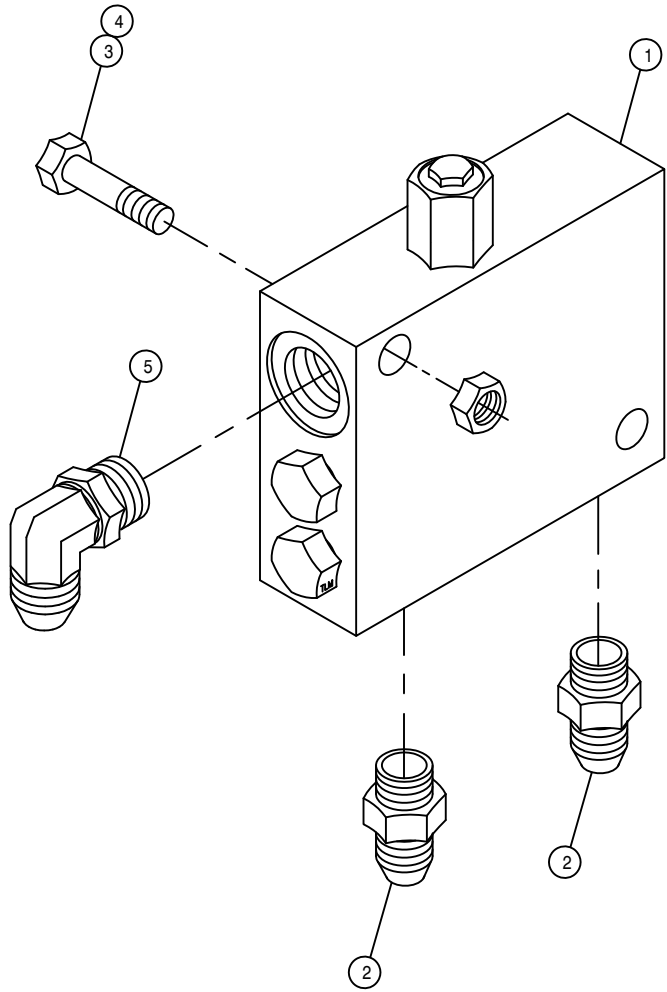

LOOP FLUSHING VALVE ASSEMBLY

DET.	QTY	PART NO.	DESCRIPTION
1	1	610580	REMOTE FLUSHING VALVE, SUND
2	2	618126	9/16MJIC-9/16MOR ADPTR
3	2	900133	3/8UNC X 2" HEX BOLT
4	2	914004	3/8UNC HEX STOVER NUT
5	1	618119	9/16MJIC-90-9/16MOR LBO

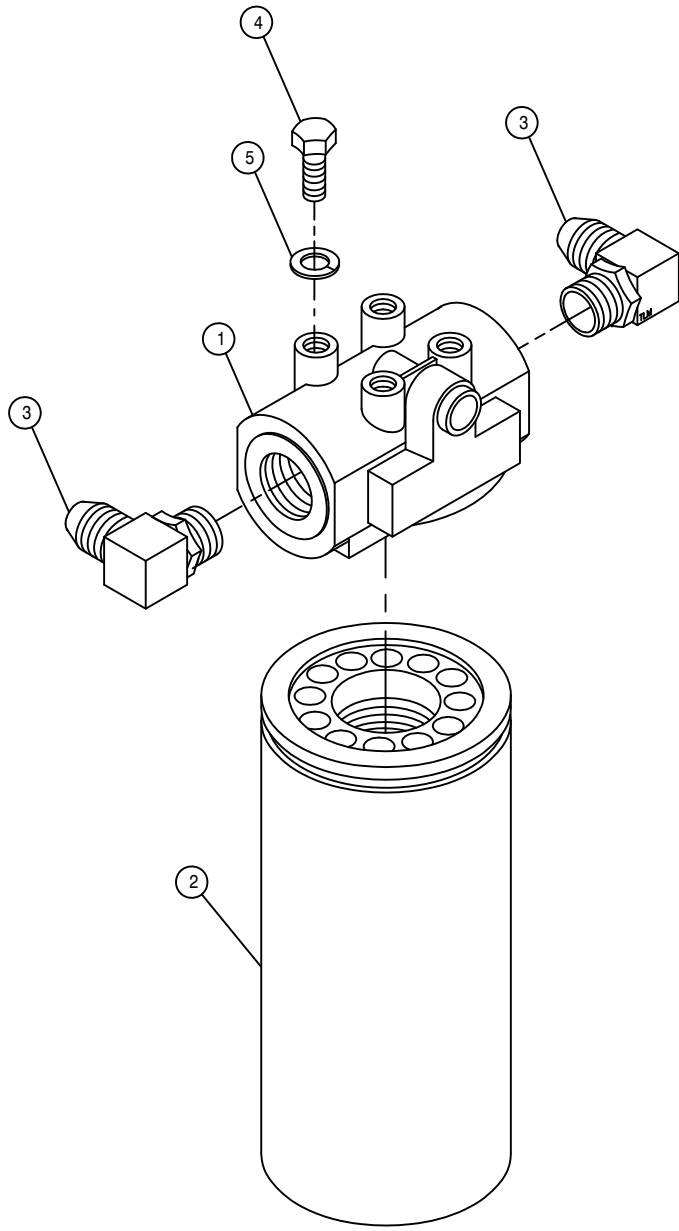

HI-PRESS FILTER ASSEMBLY

DET.	QTY	PART NO.	DESCRIPTION
1	1	605608	HYD FILTER HEAD, DONALDSON
2	1	605609	HYD FILTER ELEMENT, DONALDSON
3	2	618474	3/4MJIC-90-1 1/16MOR LBO
4	4	900128	3/8UNC X 3/4 HEX BOLT
5	4	920502	3/8 LOCK WASHER

POSITRATION VALVE ASSEMBLY

DET. QTY PART NO. DESCRIPTION

DET.	QTY	PART NO.	DESCRIPTION	
1	1	341849	POSITRACTION VALVE MT	200
2	2	920000	1/4 SAE FLAT WASHER	
3	2	505213	RED BUSH 1 X 3/4 BLK MAL	
4	1	610586	POSITRACTION VLV,ALUM,88SP60G	
5	1	614660	1IN STL TEE WLD 280	89
6	2	618156	7/8MJIC-90-3/4MNPT LBO	
7	2	618601	7/8MJIC-1 5/16MOR ADPT	
8	1	618186	1 5/16MJIC-1 5/16MOR ADPTR	
9	1	618322	1 5/16MJIC-1MNPT ADPTR	
10	2	900012	1/4UNC X 3 1/2 HEX BOLT	
11	2	900002	1/4UNC X 3/4 HEX BOLT	
12	4	914000	1/4UNC HEX STOVER NUT	

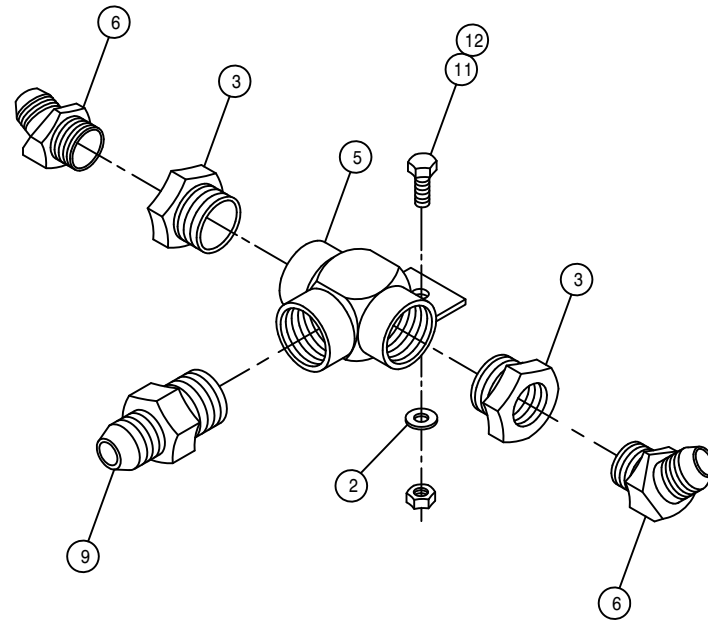
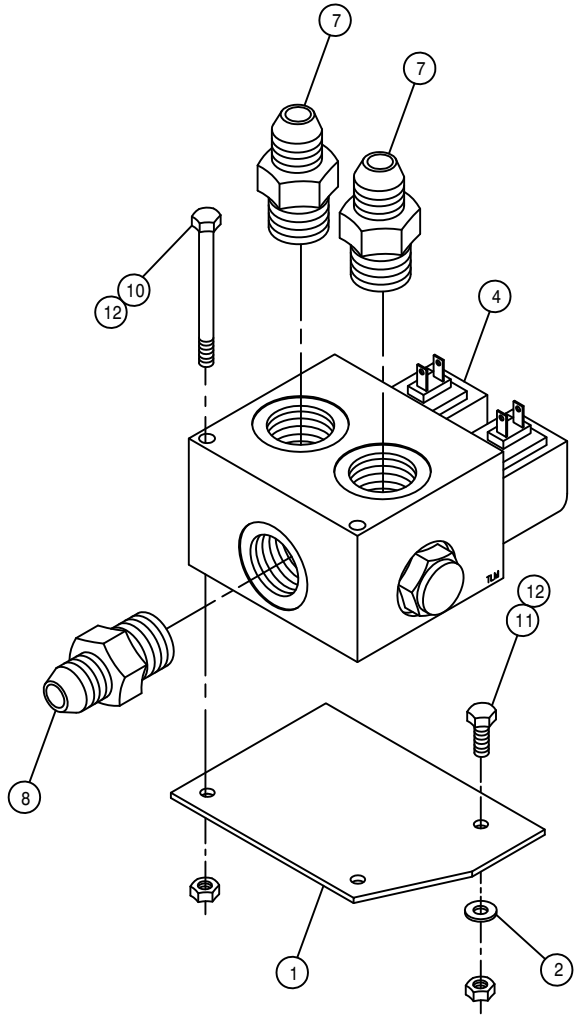

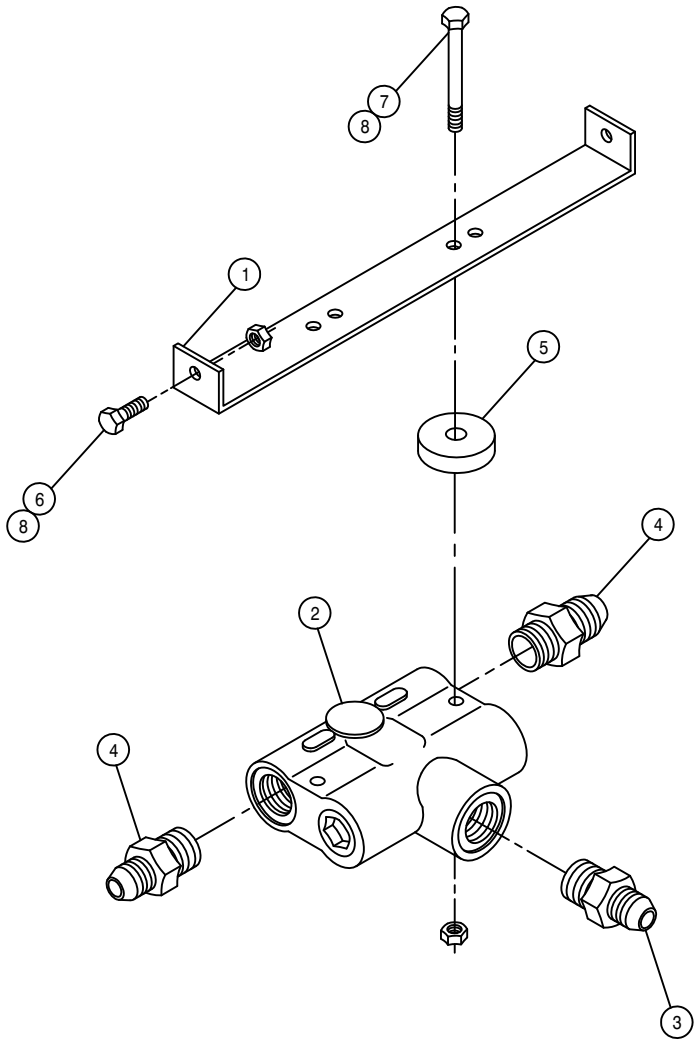

FLOW DIVIDER ASSEMBLY

DET. QTY PART NO. DESCRIPTION

DET.	QTY	PART NO.	DESCRIPTION	
1	1	341774	FLOW DIVIDER MT 280	89
2	1	607504	FLO DIV B50 2-8GPM 7/8 FOR	
3	1	611126	7/8MJIC-7/8MOR ADPTR	
4	2	618310	9/16MJIC-7/8MOR ADPTR	
5	2	748500	RUBER WASH 3/8X1/4IDX1 1/2 OD	
6	2	900002	1/4UNC X 3/4 HEX BOLT	
7	2	900008	1/4UNC X 2 1/2 HEX BOLT	
8	4	914000	1/4UNC HEX STOVER NUT	

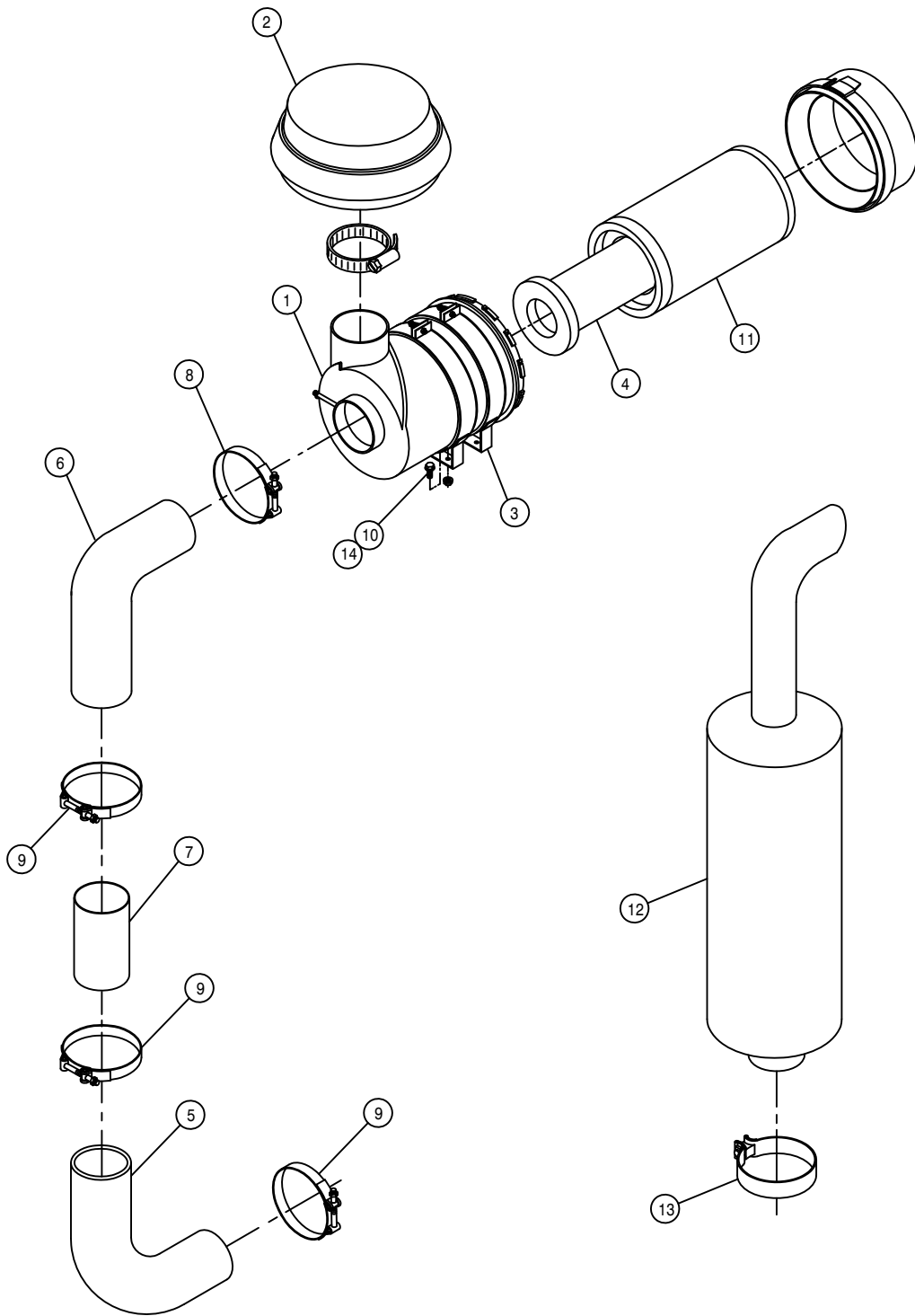

CUMMINS AIR CLEANER AND EXHAUST ASSEMBLY

DET. QTY PART NO. DESCRIPTION

1	1	311528	AIR CLEANER, PLASTIC HSG
2	1	314971	AIR CLEANER HOOD FOR 314970
3	1	311529	AIR CLEANER MT BAND FOR 311528
4	2	311531	SAFETY ELEMENT FOR 311528
5	1	316309	4" 90DEG ELBOW, RUBBER
6	1	316297	5" -4" 90DEG REDU ELBOW,RUBBER
7	1	316298	4" X 12" AIR INTAKE TUBE 97
8	1	520136	5.31/5.59 T-BOLT HOSE CLAMP SS
9	3	520134	4.31/4.59 T-BOLT HOSE CLAMP SS
10	4	470113	5/16UNC HEX FLANGE LOCK NUT
11	1	311530	PRIMARY ELEMENT FOR 311528
12	1	316366	MUFFLER, 2100/STS10/STS12
13	2	470458	MUFFLER CLAMP, 3.00 ACCUSEAL
14	4	470233	5/16UNC X 3/4 FLANGE HEX BOLT

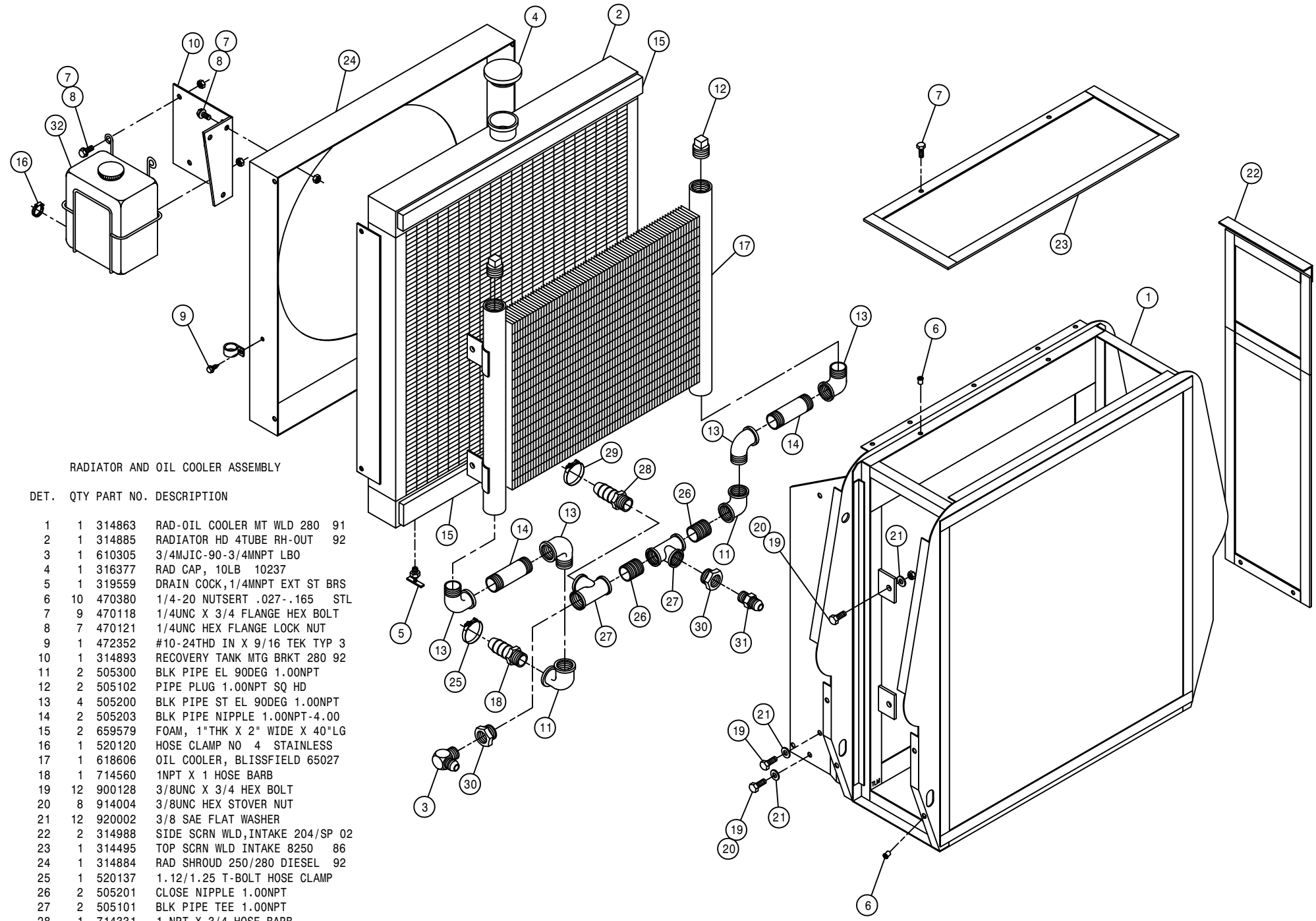

RADIATOR AND OIL COOLER ASSEMBLY

DET. QTY PART NO. DESCRIPTION

1	1	314863	RAD-OIL COOLER MT WLD 280	91
2	1	314885	RADIATOR HD 4TUBE RH-OUT	92
3	1	610305	3/4MJIC-90-3/4MNPT LBO	
4	1	316377	RAD CAP, 10LB 10237	
5	1	319559	DRAIN COCK, 1/4MNPT EXT ST BRS	
6	10	470380	1/4-20 NUTSERT .027-.165 STL	
7	9	470118	1/4UNC X 3/4 FLANGE HEX BOLT	
8	7	470121	1/4UNC HEX FLANGE LOCK NUT	
9	1	472352	#10-24THD IN X 9/16 TEK TYP 3	
10	1	314893	RECOVERY TANK MTG BRKT 280	92
11	2	505300	BLK PIPE EL 90DEG 1.00NPT	
12	2	505102	PIPE PLUG 1.00NPT SQ HD	
13	4	505200	BLK PIPE ST EL 90DEG 1.00NPT	
14	2	505203	BLK PIPE NIPPLE 1.00NPT-4.00	
15	2	659579	FOAM, 1"THK X 2" WIDE X 40"LG	
16	1	520120	HOSE CLAMP NO 4 STAINLESS	
17	1	618606	OIL COOLER, BLISSFIELD 65027	
18	1	714560	1NPT X 1 HOSE BARB	
19	12	900128	3/8UNC X 3/4 HEX BOLT	
20	8	914004	3/8UNC HEX STOVER NUT	
21	12	920002	3/8 SAE FLAT WASHER	
22	2	314988	SIDE SCR N WLD, INTAKE 204/SP 02	
23	1	314495	TOP SCR N WLD INTAKE 8250	86
24	1	314884	RAD SHROUD 250/280 DIESEL	92
25	1	520137	1.12/1.25 T-BOLT HOSE CLAMP	
26	2	505201	CLOSE NIPPLE 1.00NPT	
27	2	505101	BLK PIPE TEE 1.00NPT	
28	1	714331	1 NPT X 3/4 HOSE BARB	
29	1	520138	1.38/1.56 T-BOLT HOSE CLAMP	
30	2	505213	RED BUSH 1 X 3/4 BLK MAL	
31	1	610300	3/4MJIC-3/4MNPT ADPTR	
32	1	314767	RAD RECOVERY TANK & MTG WLD	

RIGHT FRONT LEG ASSEMBLY

DET. QTY PART NO. DESCRIPTION

1	1	127505	THRUST BEARING, FIBERGLIDE
2	1	358564	FRT LEG LWR NYL SLEEVE 280 89
3	1	358565	FRT LEG UPR NYL SLEEVE 280 89
4	1	357884	RH FRT INNER LEG WLD,204SP 02
5	4	358927	LWR BRG KPR, LEG 98
6	1	357857	RH FRT OUTER LEG WLD, 204SP 01
7	1	358971	STEERING ARM WLD,RF/LR 2100 99
8	1	358980	AIR BAG MT WLD, RF/LR 2100 99
9	1	357864	AIR BAG ARCH WLD,RF/LR204SP 01
10	1	358994	LEG WASHER, NYLON 2100 99
11	1	358995	NYLON BEARING,LWR AB MT2100 99
12	1	357870	RH UPPER HOSE MT WELD,204SP 01
13	2	470259	URETHANE BUMPER,1.25D X 1.25L
14	1	470265	KEY, .250 X .375 X 1.88 LG
15	1	471005	1/4 28 X 1/2 GREASE ZERK
16	2	471023	GREASE ZERK 1/4-28 X 45
17	1	473906	SPIRAL PIN, 1/2 X 2 1/2 LG
18	1	483061	1.65 ID X 2.50 OD X .188T WASH
19	8	900064	5/16UNC X 3/4 HEX BOLT
20	2	900263	1/2UNC X 1" HEX BOLT
21	4	900265	1/2UNC X 1 1/2 HEX BOLT
22	4	900267	1/2UNC X 2" HEX BOLT
23	1	900390	5/8UNC X 2 1/2 SOCKET CAP SCR
24	4	900836	5/8UNF X 3 1/4 HEX BOLT GR8
25	3	910008	1/2UNC HEX NUT
26	8	914008	1/2UNC HEX STOVER NUT
27	14	914811	5/8UNF HEX NUT GR8
28	8	920501	5/16 LOCK WASHER
29	7	920504	1/2 LOCK WASHER
30	1	920505	5/8 LOCK WASHER
31	1	358759	LEG MT V-PLT WLD, 284T 94
32	1	358831	AIRIDE SPRING 98
33	1	342637	NYL HOSE SLEEVE,2.96ID X 54.00
34	1	483063	1.65 ID X 2.50 OD X .074T WASH
35	2	358990	NYLON GUIDE, 2100 LEG 99
36	1	358991	INNER KEEPER,NYL GUIDE,2100 99
37	1	358992	OUTER KEEPER,NYL GUIDE,2100 99
38	1	358993	NYLON GUIDE BACK PLATE,2100 99
39	3	900837	5/8UNF X 3 1/2 HEX BOLT GR8
40	2	910002	5/16UNC HEX NUT
41	1	470343	TUBE CLAMP BODY, .875-.875
42	1	470276	CLAMP COVER PLATE,SNGL, 2.55LG
43	1	470280	STACK BOLT, 5/16UNC X 1 3/4
44	1	470281	STACK BOLT SAFETY LOCK PLATE
45	1	470270	HOSE CLAMP BODY, .530-.680
46	1	910013	3/4UNF HEX NUT
47	2	914002	5/16UNC HEX STOVER NUT
48	1	920506	3/4 LOCK WASHER
49	2	900065	5/16UNC X 1" HEX BOLT
50	1	900068	5/16UNC X 1 3/4 HEX BOLT
51	2	900069	5/16UNC X 2" HEX BOLT
52	4	900264	1/2UNC X 1 1/4 HEX BOLT
53	1	470338	AIR TANK VALVE,1/4MNPT W/CAP

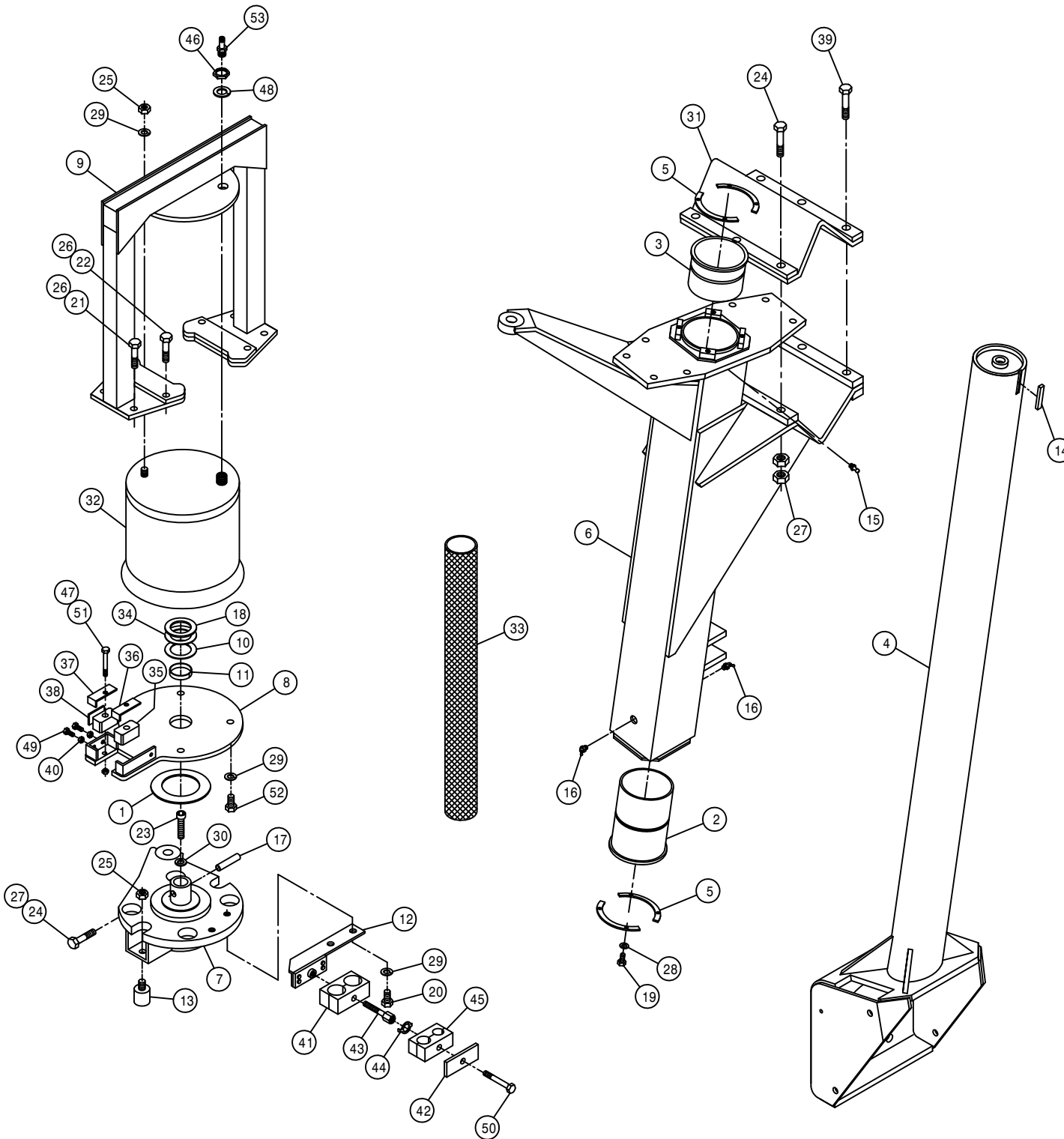

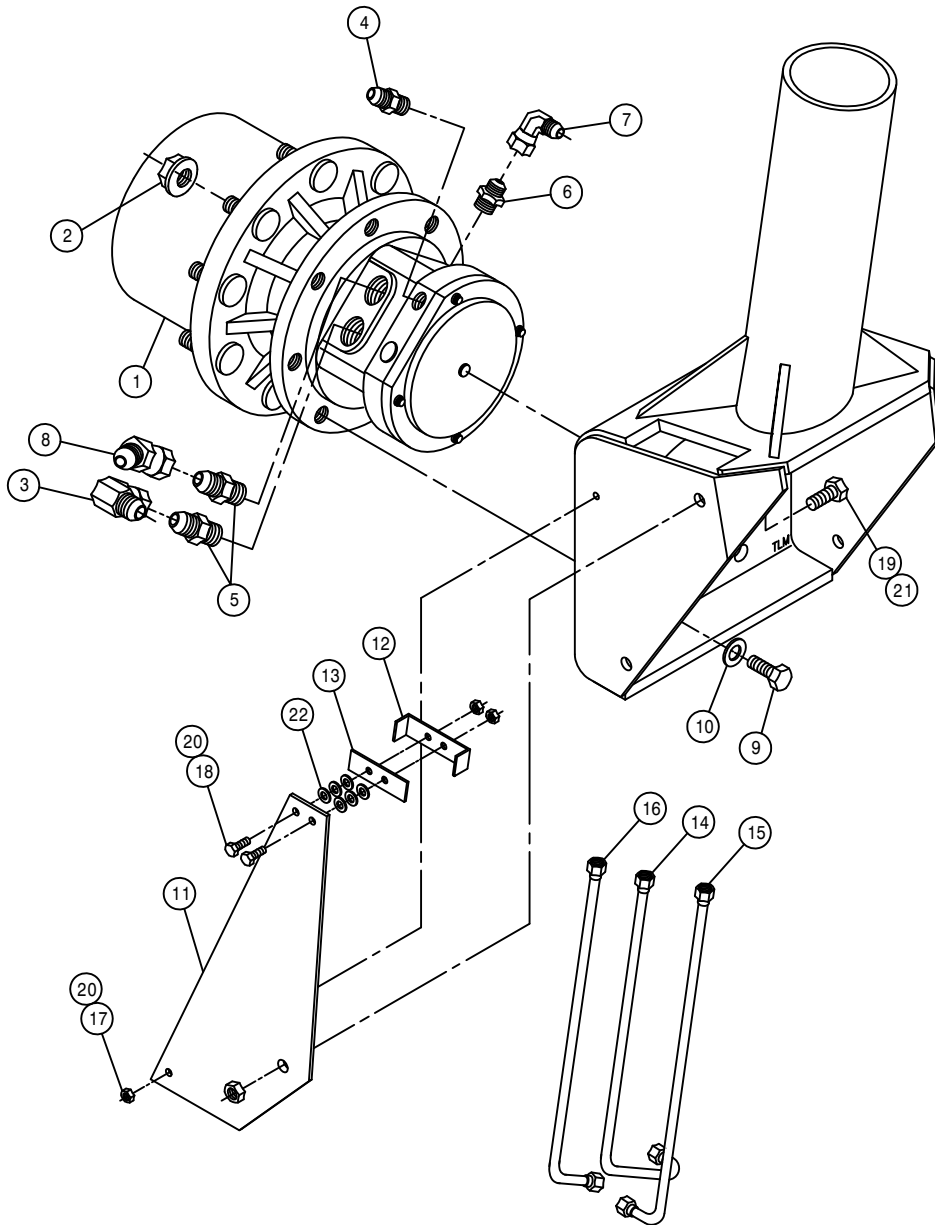

RIGHT FRONT LEG ASSEMBLY W/W1M1 HUB

DET.	QTY	PART NO.	DESCRIPTION
1	1	610717	TORQ HUB,24:1 W1M1 INTEGRATED
2	9	470140	5/8UNF HEX SMTH FLANGE NUT PLT
3	1	618301	7/8MJIC-90-7/8FJIC SWIV LBO
4	1	618304	9/16MJIC-7/16MOR ADPTR
5	2	618309	7/8MJIC-1 1/16MOR ADPTR
6	1	618327	3/4MJIC-7/8MOR ADPTR
7	1	618609	3/4MJIC-90-3/4FJIC SWIV LBO
8	1	618628	7/8MJIC-45-7/8FJIC SWIV LBO
9	8	900333	5/8UNC X 1 1/2 HEX BOLT
10	8	920505	5/8 LOCK WASHER
11	1	357863	HYD TUBE MT, 204SP LEG 2001
12	1	358739	FRT LEG HYD TUBE CLMP, 284 94
13	1	358740	FRT LEG HYD TUBE KPR, 284 94
14	1	615800	RH FRT LEG INNER HYD TUBE204SP
15	1	615802	FRT LEG CNTR HYD TUBE 204SP
16	1	615803	FRT LEG OUTER HYD TUBE 204SP
17	1	900002	1/4UNC X 3/4 HEX BOLT
18	2	900006	1/4UNC X 1 3/4 HEX BOLT
19	1	900263	1/2UNC X 1" HEX BOLT
20	3	914000	1/4UNC HEX STOVER NUT
21	1	914008	1/2UNC HEX STOVER NUT
22	6	920000	1/4 SAE FLAT WASHER

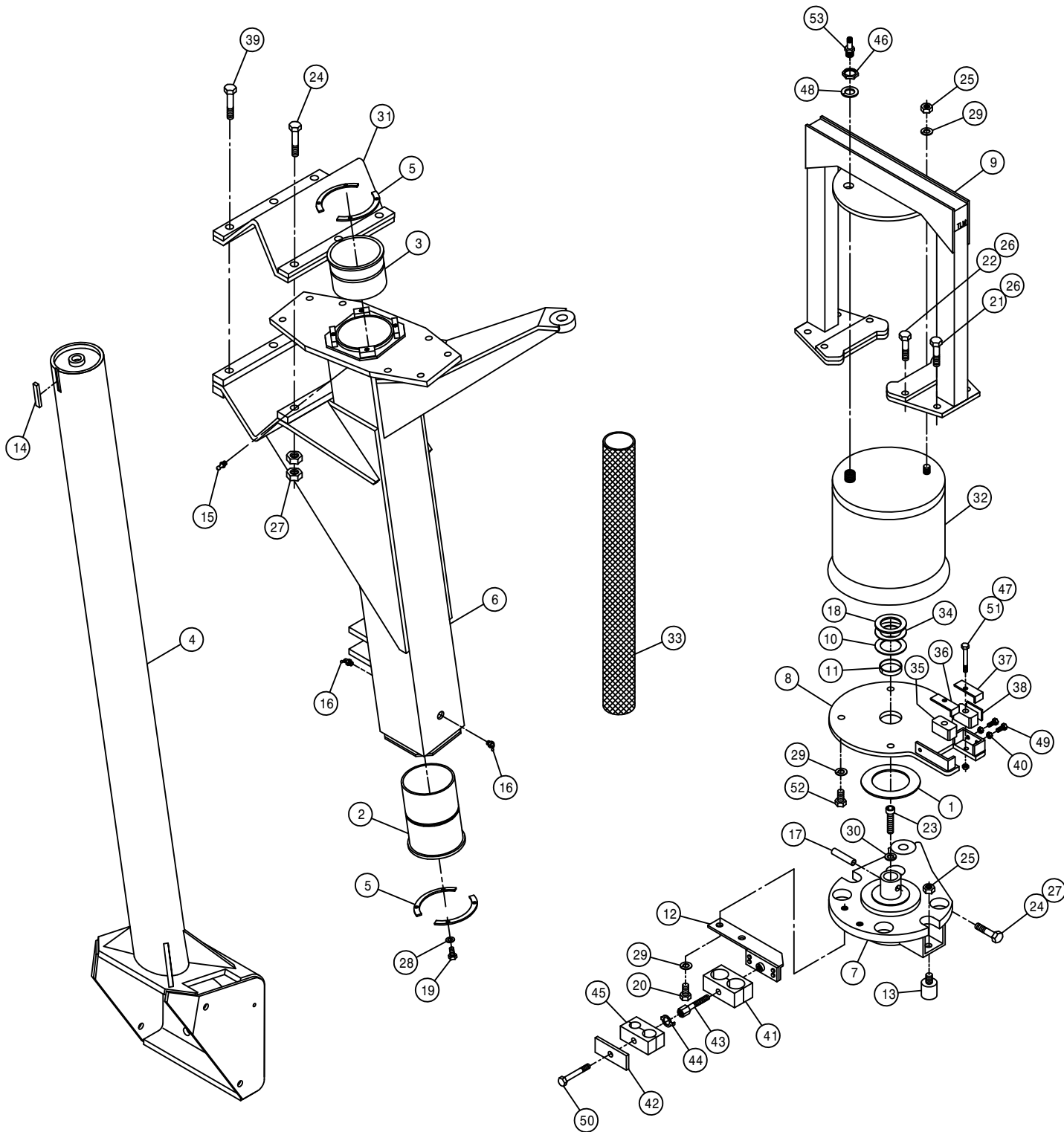

LEFT FRONT LEG ASSEMBLY

DET.	QTY	PART NO.	DESCRIPTION
1	1	127505	THRUST BEARING, FIBERGLIDE
2	1	358564	FRT LEG LWR NYL SLEEVE 280 89
3	1	358565	FRT LEG UPR NYL SLEEVE 280 89
4	1	357885	LH FRT INNER LEG WLD,204SP 02
5	4	358927	LWR BRG KPR, LEG 98
6	1	357858	LH FRT OUTER LEG WLD, 204SP 01
7	1	358972	STEERING ARM WLD,LF/RR 2100 99
8	1	358981	AIR BAG MT WLD, LF/RR 2100 99
9	1	357865	AIR BAG ARCH WLD,LF/RR204SP 01
10	1	358994	LEG WASHER, NYLON 2100 99
11	1	358995	NYLON BEARING,LWR AB MT2100 99
12	1	357871	LH UPPER HOSE MT WELD,204SP 01
13	2	470259	URETHANE BUMPER,1.25D X 1.25L
14	1	470265	KEY, .250 X .375 X 1.88 LG
15	1	471005	1/4 28 X 1/2 GREASE ZERK
16	2	471023	GREASE ZERK 1/4-28 X 45
17	1	473906	SPIRAL PIN, 1/2 X 2 1/2 LG
18	1	483061	1.65 ID X 2.50 OD X .188T WASH
19	8	900064	5/16UNC X 3/4 HEX BOLT
20	2	900263	1/2UNC X 1" HEX BOLT
21	4	900265	1/2UNC X 1 1/2 HEX BOLT
22	4	900267	1/2UNC X 2" HEX BOLT
23	1	900390	5/8UNC X 2 1/2 SOCKET CAP SCR
24	4	900836	5/8UNF X 3 1/4 HEX BOLT GR8
25	3	910008	1/2UNC HEX NUT
26	8	914008	1/2UNC HEX STOVER NUT
27	14	914811	5/8UNF HEX NUT GR8
28	8	920501	5/16 LOCK WASHER
29	7	920504	1/2 LOCK WASHER
30	1	920505	5/8 LOCK WASHER
31	1	358759	LEG MT V-PLT WLD, 284T 94
32	1	358831	AIRIDE SPRING 98
33	1	342637	NYL HOSE SLEEVE,2.96ID X 54.00
34	1	483063	1.65 ID X 2.50 OD X .074T WASH
35	2	358990	NYLON GUIDE, 2100 LEG 99
36	1	358991	INNER KEEPER,NYL GUIDE,2100 99
37	1	358992	OUTER KEEPER,NYL GUIDE,2100 99
38	1	358993	NYLON GUIDE BACK PLATE,2100 99
39	3	900837	5/8UNF X 3 1/2 HEX BOLT GR8
40	2	910002	5/16UNC HEX NUT
41	1	470343	TUBE CLAMP BODY, .875-. 875
42	1	470276	CLAMP COVER PLATE,SNGL, 2.55LG
43	1	470280	STACK BOLT, 5/16UNC X 1 3/4
44	1	470281	STACK BOLT SAFETY LOCK PLATE
45	1	470270	HOSE CLAMP BODY, .530-.680
46	1	910013	3/4UNF HEX NUT
47	2	914002	5/16UNC HEX STOVER NUT
48	1	920506	3/4 LOCK WASHER
49	2	900065	5/16UNC X 1" HEX BOLT
50	1	900068	5/16UNC X 1 3/4 HEX BOLT
51	2	900069	5/16UNC X 2" HEX BOLT
52	4	900264	1/2UNC X 1 1/4 HEX BOLT
53	1	470338	AIR TANK VALVE,1/4MNPT W/CAP

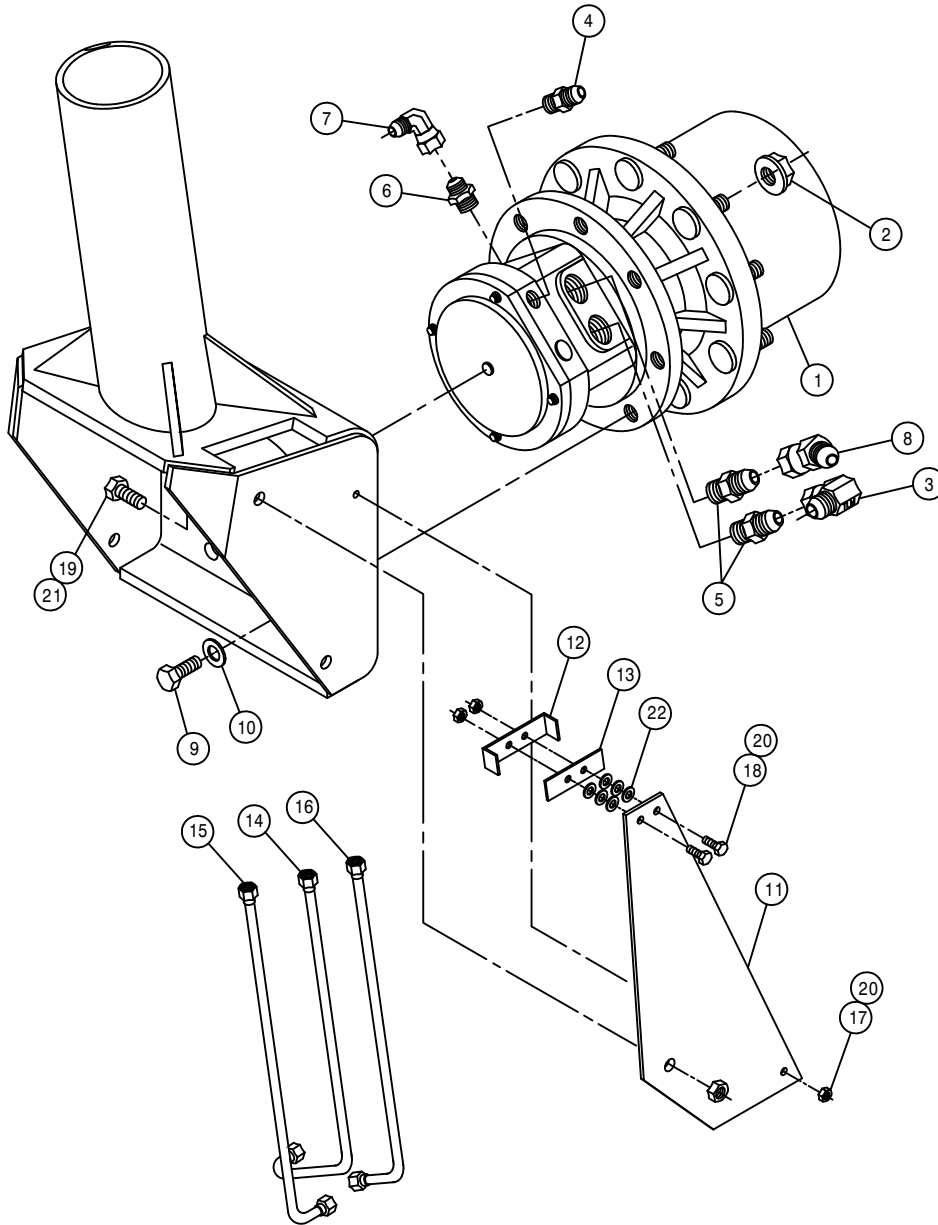

LEFT FRONT ASSEMBLY W/W1M1 HUB

DET.	QTY	PART NO.	DESCRIPTION
1	1	610717	TORQ HUB,24:1 W1M1 INTEGRATED
2	9	470140	5/8UNF HEX SMTH FLANGE NUT PLT
3	1	618301	7/8MJIC-90-7/8FJIC SWIV LBO
4	1	618304	9/16MJIC-7/16MOR ADPTR
5	2	618309	7/8MJIC-1 1/16MOR ADPTR
6	1	618327	3/4MJIC-7/8MOR ADPTR
7	1	618609	3/4MJIC-90-3/4FJIC SWIV LBO
8	1	618628	7/8MJIC-45-7/8FJIC SWIV LBO
9	8	900333	5/8UNC X 1 1/2 HEX BOLT
10	8	920505	5/8 LOCK WASHER
11	1	357863	HYD TUBE MT, 204SP LEG 2001
12	1	358739	FRT LEG HYD TUBE CLMP, 284 94
13	1	358740	FRT LEG HYD TUBE KPR, 284 94
14	1	615801	LH FRT LEG INNER HYD TUBE204SP
15	1	615802	FRT LEG CNTR HYD TUBE 204SP
16	1	615803	FRT LEG OUTER HYD TUBE 204SP
17	1	900002	1/4UNC X 3/4 HEX BOLT
18	2	900006	1/4UNC X 1 3/4 HEX BOLT
19	1	900263	1/2UNC X 1" HEX BOLT
20	3	914000	1/4UNC HEX STOVER NUT
21	1	914008	1/2UNC HEX STOVER NUT
22	6	920000	1/4 SAE FLAT WASHER

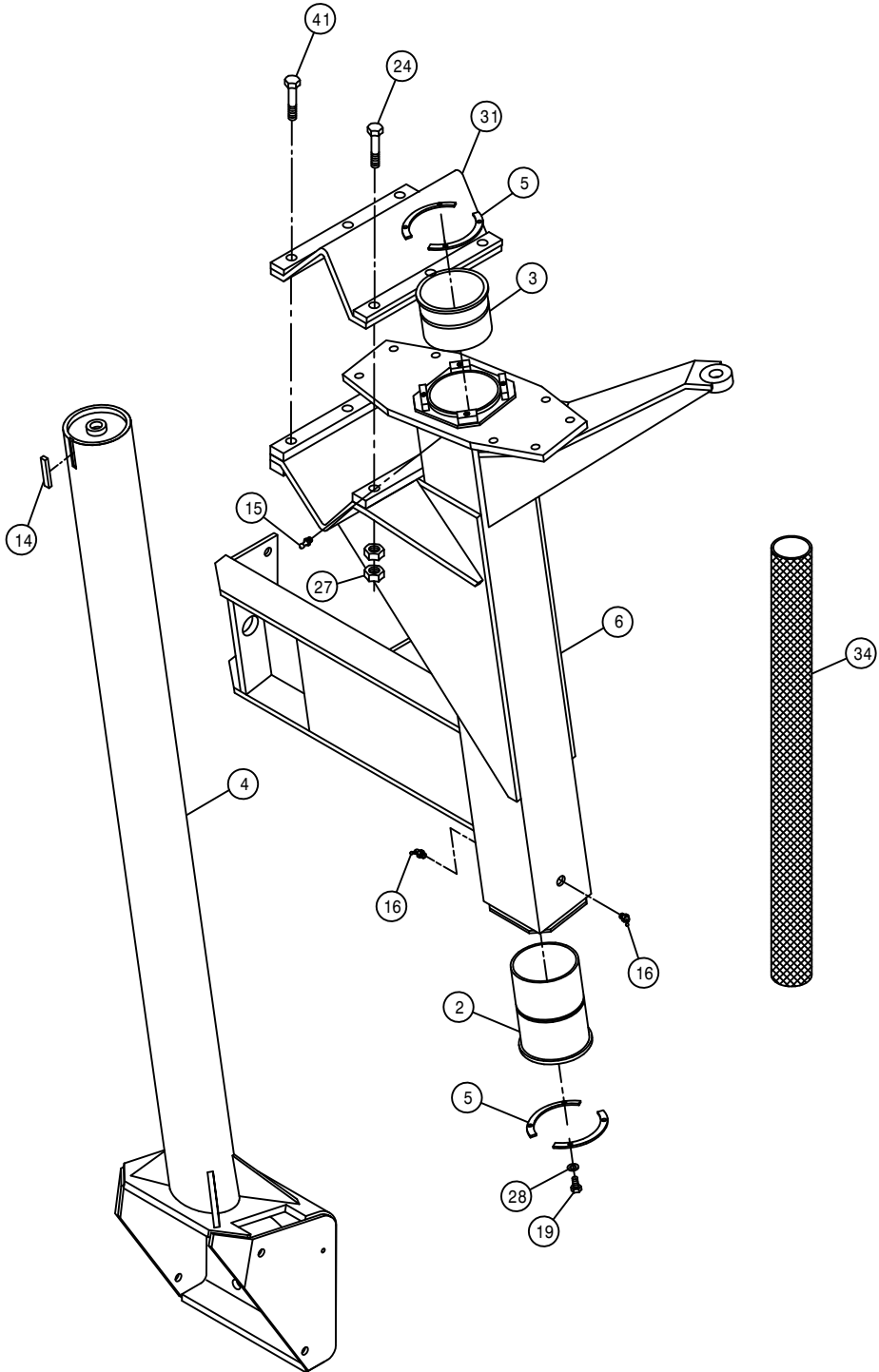

RIGHT REAR LEG ASSEMBLY

DET.	QTY	PART NO.	DESCRIPTION
1	1	483062	3.00 ID X 4.62 OD X .125T WASH
2	1	358564	FRT LEG LWR NYL SLEEVE 280 89
3	1	358565	FRT LEG UPR NYL SLEEVE 280 89
4	1	357886	RH REAR INNER LEG WLD,204SP 02
5	4	358927	LWR BRG KPR, LEG 98
6	1	357859	RH REAR OUTER LEG WLD,204SP 01
7	1	358972	STEERING ARM WLD,LF/RR 2100 99
8	1	358981	AIR BAG MT WLD, LF/RR 2100 99
9	1	357865	AIR BAG ARCH WLD,LF/RR204SP 01
10	1	358994	LEG WASHER, NYLON 2100 99
11	1	358995	NYLON BEARING,LWR AB MT2100 99
12	2	900069	5/16UNC X 2" HEX BOLT
13	2	470259	URETHANE BUMPER,1.25D X 1.25L
14	1	470265	KEY, .250 X .375 X 1.88 LG
15	1	471005	1/4 28 X 1/2 GREASE ZERK
16	2	471023	GREASE ZERK 1/4-28 X 45
17	1	473906	SPIRAL PIN, 1/2 X 2 1/2 LG
18	1	483061	1.65 ID X 2.50 OD X .188T WASH
19	8	900064	5/16UNC X 3/4 HEX BOLT
20	4	900264	1/2UNC X 1 1/4 HEX BOLT
21	4	900265	1/2UNC X 1 1/2 HEX BOLT
22	4	900267	1/2UNC X 2" HEX BOLT
23	1	900390	5/8UNC X 2 1/2 SOCKET CAP SCR
24	4	900836	5/8UNF X 3 1/4 HEX BOLT GR8
25	3	910008	1/2UNC HEX NUT
26	8	914008	1/2UNC HEX STOVER NUT
27	14	914811	5/8UNF HEX NUT GR8
28	8	920501	5/16 LOCK WASHER
29	5	920504	1/2 LOCK WASHER
30	1	920505	5/8 LOCK WASHER
31	1	358759	LEG MT V-PLT WLD, 284T 94
32	1	358831	AIRIDE SPRING 98
33	2	900065	5/16UNC X 1" HEX BOLT
34	1	342635	NYL HOSE SLEEVE,2.64ID X 60.00
35	2	358990	NYLON GUIDE, 2100 LEG 99
36	1	358991	INNER KEEPER,NYL GUIDE,2100 99
37	1	358992	OUTER KEEPER,NYL GUIDE,2100 99
38	1	358993	NYLON GUIDE BACK PLATE,2100 99
39	1	483063	1.65 ID X 2.50 OD X .074T WASH
40	1	470338	AIR TANK VALVE,1/4MNPT W/CAP
41	3	900837	5/8UNF X 3 1/2 HEX BOLT GR8
42	2	910002	5/16UNC HEX NUT
43	1	910013	3/4UNF HEX NUT
44	2	914002	5/16UNC HEX STOVER NUT
45	1	920506	3/4 LOCK WASHER

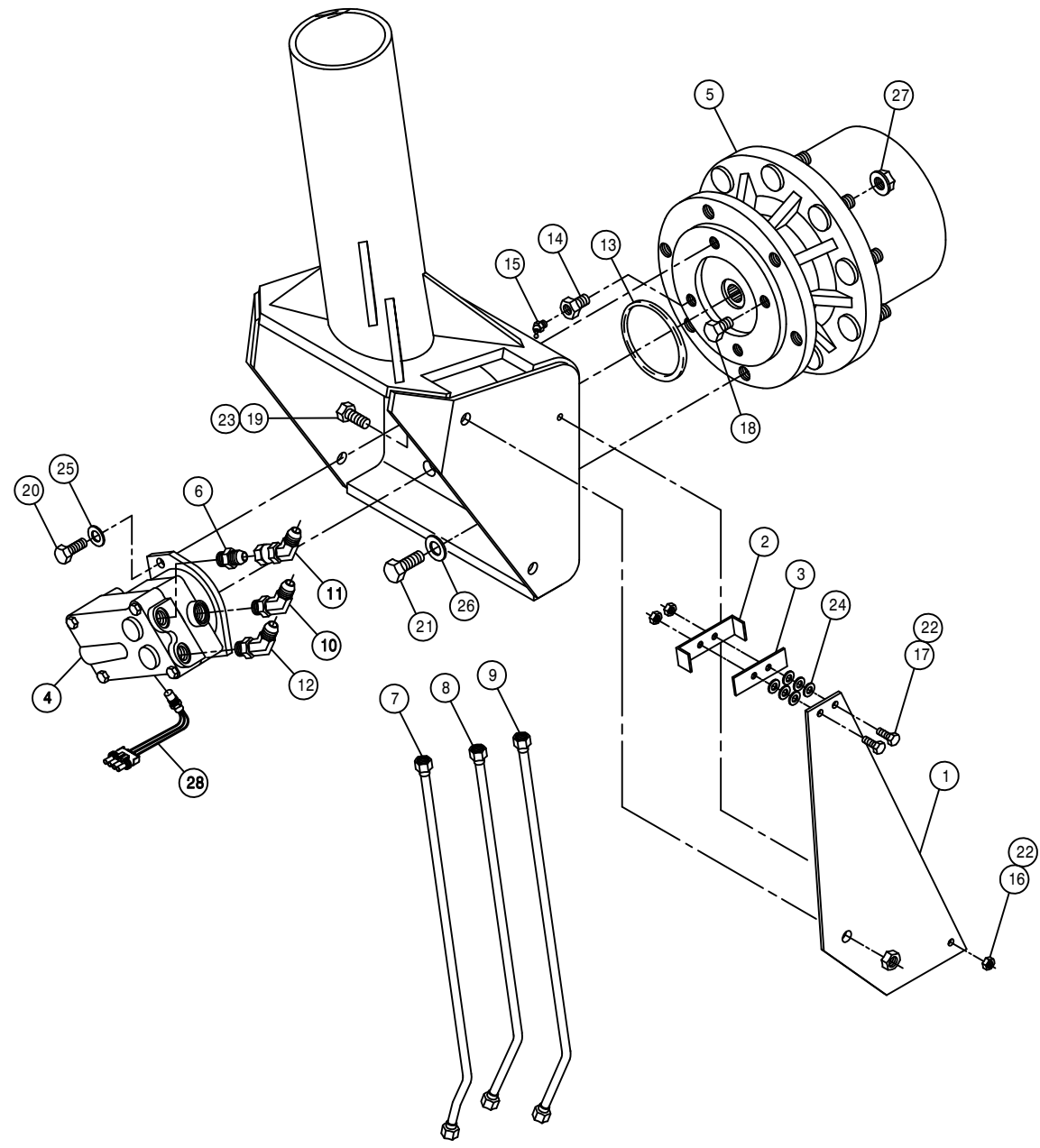

RIGHT REAR LEG ASSEMBLY

DET.	QTY	PART NO.	DESCRIPTION
1	1	357863	HYD TUBE MT, 204SP LEG 2001
2	1	358739	FRT LEG HYD TUBE CLMP, 284 94
3	1	358740	FRT LEG HYD TUBE KPR, 284 94
4	1	610721	SUND M25-3000 WHL MTR W/SENSOR
5	1	610660	TORQ HUB, 18:1 B-MT W1BFFZ
6	1	611126	7/8MJIC-7/8MOR ADPTR
7	1	615804	REAR LEG INNER HYD TUBE 204SP
8	1	615805	REAR LEG CNTR HYD TUBE 204SP
9	1	615806	REAR LEG OUTER HYD TUBE 204SP
10	1	618315	3/4MJIC-45-3/4MOR LBO
11	1	618628	7/8MJIC-45-7/8FJIC SWIV LBO
12	1	618644	7/8MJIC-45-7/8MOR LBO
13	1	870045	O-RING 4 1/8 OD X 4 ID
14	1	610556	1/2UNC X 1/2 ZERK BOLT T-HUB
15	1	471023	GREASE ZERK 1/4-28 X 45
16	1	900002	1/4UNC X 3/4 HEX BOLT
17	2	900006	1/4UNC X 1 3/4 HEX BOLT
18	1	900260	1/2UNC X 1/2 H BOLT GR2 UNPLT
19	1	900263	1/2UNC X 1" HEX BOLT
20	2	900265	1/2UNC X 1 1/2 HEX BOLT
21	6	900333	5/8UNC X 1 1/2 HEX BOLT
22	3	914000	1/4UNC HEX STOVER NUT
23	1	914008	1/2UNC HEX STOVER NUT
24	6	920000	1/4 SAE FLAT WASHER
25	2	920504	1/2 LOCK WASHER
26	6	920505	5/8 LOCK WASHER
27	9	470140	5/8UNF HEX SMTH FLANGE NUT PLT
28	1	610625	SENSOR, WHL MOTOR 610621/610671

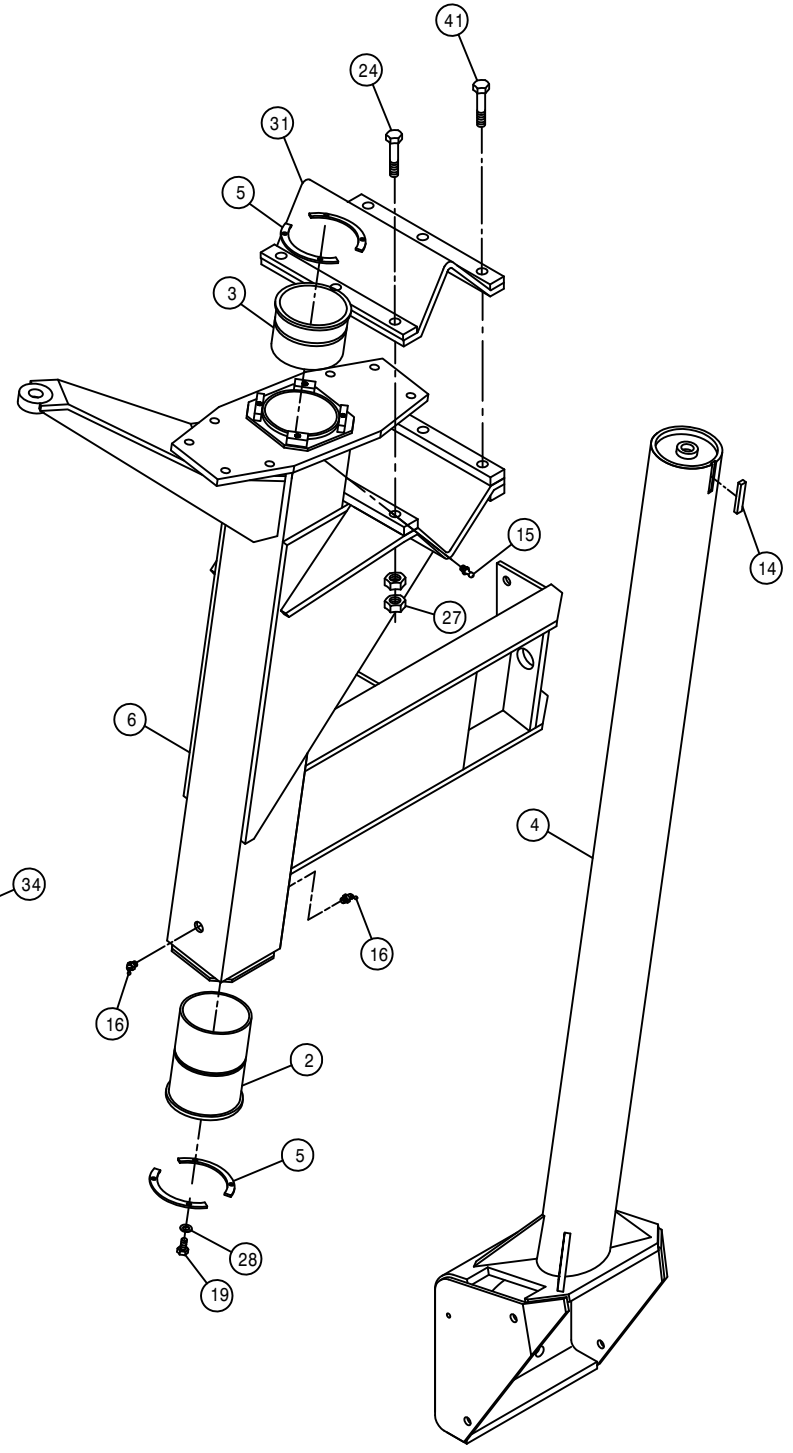
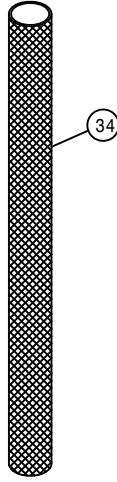
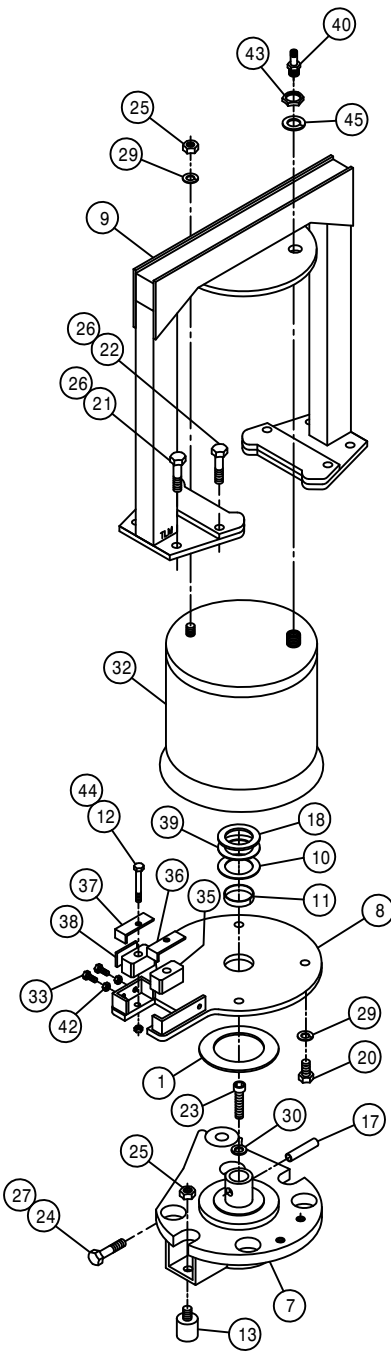

LEFT REAR LEG ASSEMBLY

DET.	QTY	PART NO.	DESCRIPTION
	1	483062	3.00 ID X 4.62 OD X .125T WASH
	1	358564	FRT LEG LWR NYL SLEEVE 280 89
	1	358565	FRT LEG UPR NYL SLEEVE 280 89
	1	357887	LH REAR INNER LEG WLD,204SP 02
	4	358927	LWR BRG KPR, LEG 98
	1	357860	LH REAR OUTER LEG WLD,204SP 01
	7	358971	STEERING ARM WLD,RF/LR 2100 99
	1	358980	AIR BAG MT WLD, RF/LR 2100 99
	9	357864	AIR BAG ARCH WLD,RF/LR204SP 01
	10	358994	LEG WASHER, NYLON 2100 99
	11	358995	NYLON BEARING,LWR AB MT2100 99
	12	900069	5/16UNC X 2" HEX BOLT
	13	470259	URETHANE BUMPER,1.25D X 1.25L
	14	470265	KEY, .250 X .375 X 1.88 LG
	15	471005	1/4 28 X 1/2 GREASE ZERK
	16	471023	GREASE ZERK 1/4-28 X 45
	17	473906	SPIRAL PIN, 1/2 X 2 1/2 LG
	18	483061	1.65 ID X 2.50 OD X .188T WASH
	19	900064	5/16UNC X 3/4 HEX BOLT
	20	900264	1/2UNC X 1 1/4 HEX BOLT
	21	900265	1/2UNC X 1 1/2 HEX BOLT
	22	900267	1/2UNC X 2" HEX BOLT
	23	900390	5/8UNC X 2 1/2 SOCKET CAP SCR
	24	900836	5/8UNF X 3 1/4 HEX BOLT GR8
	25	910008	1/2UNC HEX NUT
	26	914008	1/2UNC HEX STOVER NUT
	27	914811	5/8UNF HEX NUT GR8
	28	920501	5/16 LOCK WASHER
	29	920504	1/2 LOCK WASHER
	30	920505	5/8 LOCK WASHER
	31	358759	LEG MT V-PLT WLD, 284T 94
	32	358831	AIRIDE SPRING 98
	33	900065	5/16UNC X 1" HEX BOLT
	34	342635	NYL HOSE SLEEVE,2.64ID X 60.00
	35	358990	NYLON GUIDE, 2100 LEG 99
	36	358991	INNER KEEPER,NYL GUIDE,2100 99
	37	358992	OUTER KEEPER,NYL GUIDE,2100 99
	38	358993	NYLON GUIDE BACK PLATE,2100 99
	39	483063	1.65 ID X 2.50 OD X .074T WASH
	40	470338	AIR TANK VALVE,1/4MNPT W/CAP
	41	900837	5/8UNF X 3 1/2 HEX BOLT GR8
	42	910002	5/16UNC HEX NUT
	43	910013	3/4UNC HEX NUT
	44	914002	5/16UNC HEX STOVER NUT
	45	920506	3/4 LOCK WASHER

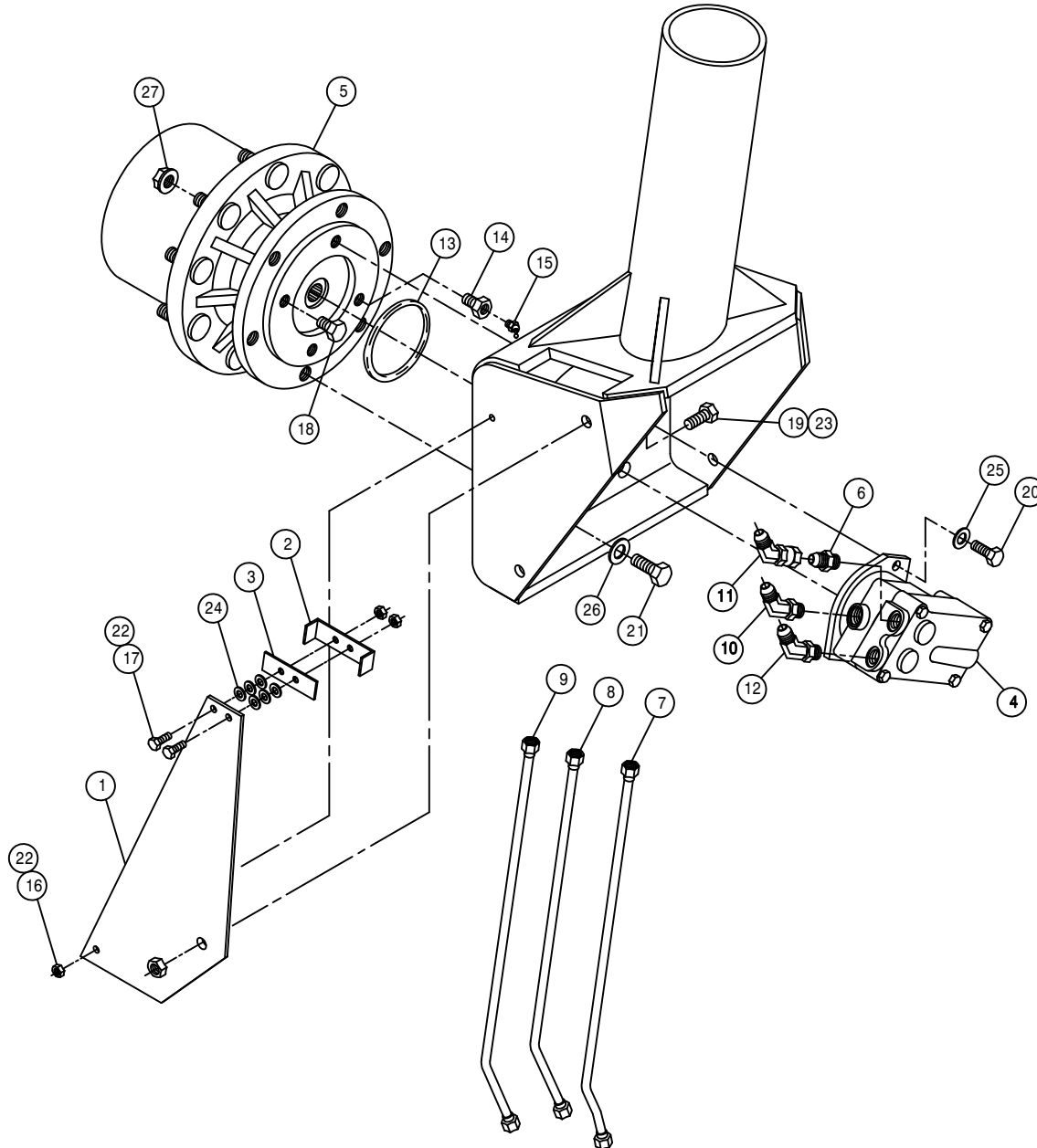

LEFT REAR LEG ASSEMBLY

DET.	QTY	PART NO.	DESCRIPTION
1	1	357863	HYD TUBE MT, 204SP LEG 2001
2	1	358739	FRT LEG HYD TUBE CLMP, 284 94
3	1	358740	FRT LEG HYD TUBE KPR, 284 94
4	1	610567	SUND M25-3000 WHL MTR 1.5CI
5	1	610660	TORQ HUB, 18:1 B-MT W1BFFZ
6	1	611126	7/8MJIC-7/8MOR ADPTR
7	1	615804	REAR LEG INNER HYD TUBE 204SP
8	1	615805	REAR LEG CNTR HYD TUBE 204SP
9	1	615806	REAR LEG OUTER HYD TUBE 204SP
10	1	618315	3/4MJIC-45-3/4MOR LBO
11	1	618628	7/8MJIC-45-7/8FJIC SWIV LBO
12	1	618644	7/8MJIC-45-7/8MOR LBO
13	1	870045	O-RING 4 1/8 OD X 4 ID
14	1	610556	1/2UNC X 1/2 ZERK BOLT T-HUB
15	1	471023	GREASE ZERK 1/4-28 X 45
16	1	900002	1/4UNC X 3/4 HEX BOLT
17	2	900006	1/4UNC X 1 3/4 HEX BOLT
18	1	900260	1/2UNC X 1/2 H BOLT GR2 UNPLT
19	1	900263	1/2UNC X 1" HEX BOLT
20	2	900265	1/2UNC X 1 1/2 HEX BOLT
21	6	900333	5/8UNC X 1 1/2 HEX BOLT
22	3	914000	1/4UNC HEX STOVER NUT
23	1	914008	1/2UNC HEX STOVER NUT
24	6	920000	1/4 SAE FLAT WASHER
25	2	920504	1/2 LOCK WASHER
26	6	920505	5/8 LOCK WASHER
27	9	470140	5/8UNF HEX SMTH FLANGE NUT PLT

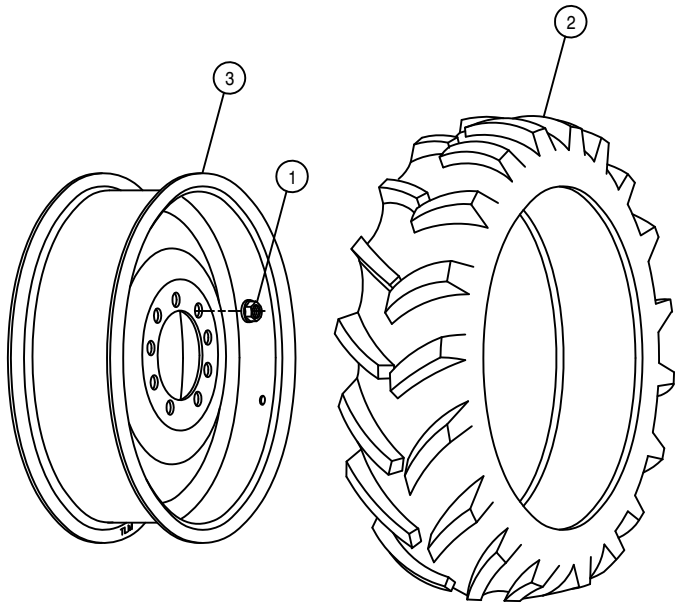

TIRE RIM ASSEMBLY

DET.	QTY	PART NO.	DESCRIPTION
1	9	470140	5/8UNF HEX SMTH FLANGE NUT PLT
2	1	820063	11.2-38 TL GOODYEAR TIRE
3	1	821050	RIM WLD, W10 X 38, W1M1 204

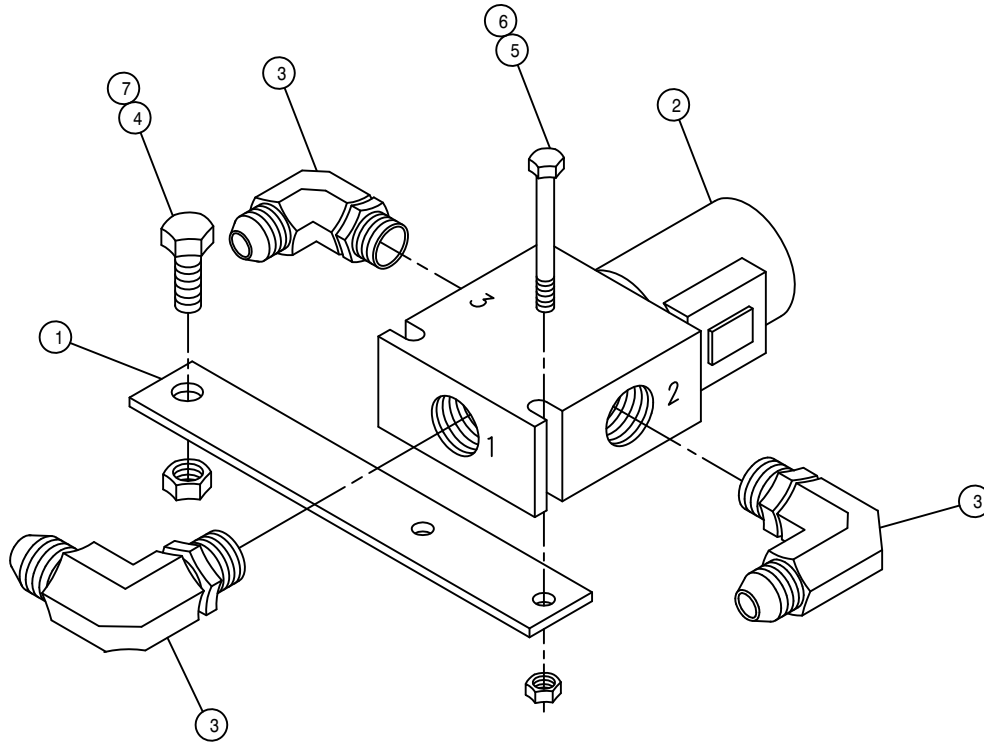

BRAKE SOLENOID ASSEMBLY

DET. QTY PART NO. DESCRIPTION

1	1	342332	PARK BRAKE SOL VLV MT	97
2	1	610318	HYD SOLE VLV, 2P-3W, 9/16FOR, 12V	
3	3	618119	9/16MJIC-90-9/16MOR LBO	
4	1	914004	3/8UNC HEX STOVER NUT	
5	2	900006	1/4UNC X 1 3/4 HEX BOLT	
6	2	914000	1/4UNC HEX STOVER NUT	
7	1	900129	3/8UNC X 1" HEX BOLT	

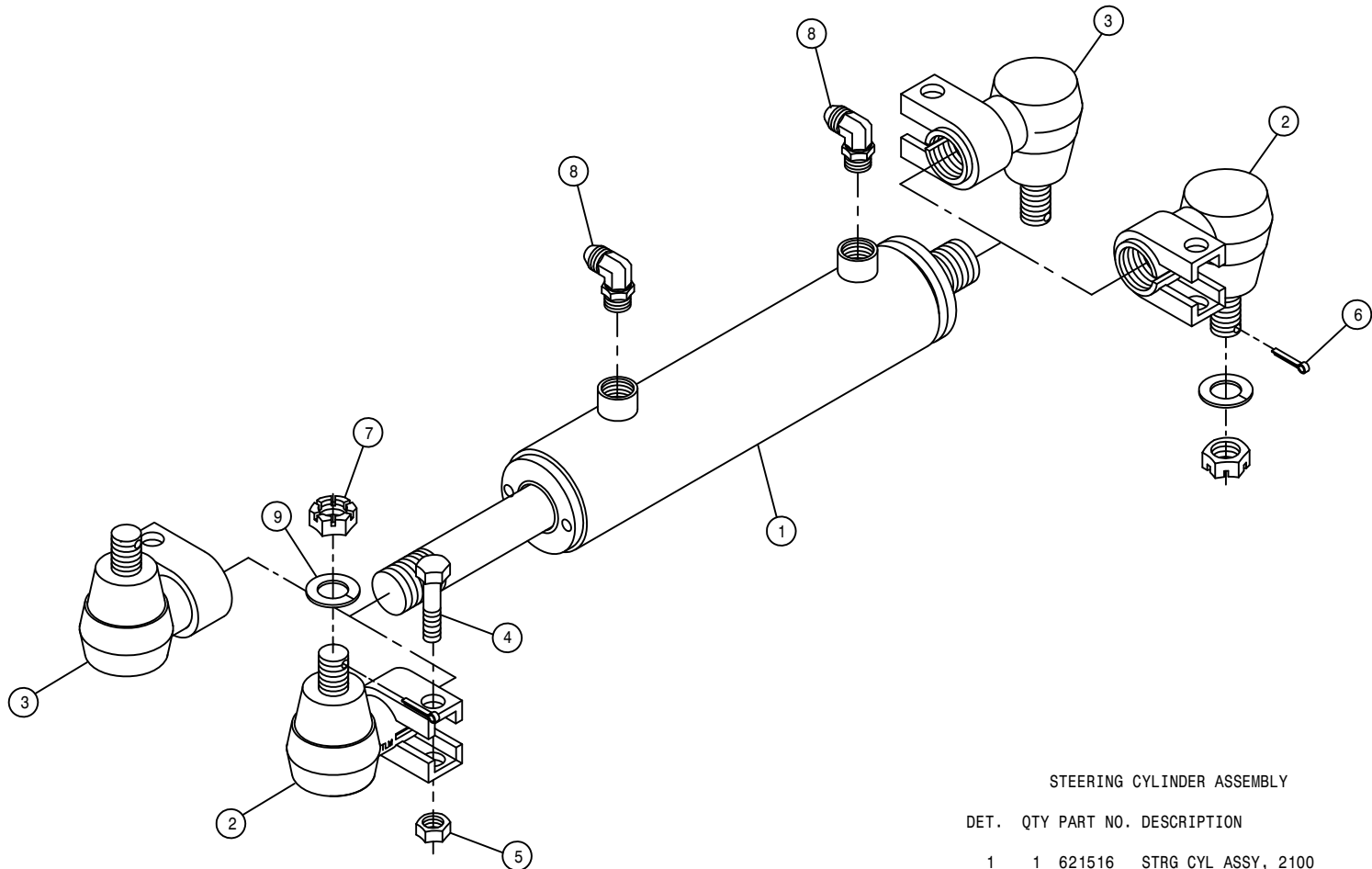

STEERING CYLINDER ASSEMBLY

DET.	QTY	PART NO.	DESCRIPTION
	1	621516	STRG CYL ASSY, 2100
	2	749312	RH STRG CYL SWIV ASSY
	2	749313	LH STRG CYL SWIV ASSY
	2	900268	1/2UNC X 2 1/2 HEX BOLT
	2	914008	1/2UNC HEX STOVER NUT
	2	390984	COTTER PIN 1/8 X 1 1/4
	2	822040	5/8-18UNF SLOTTED HEX NUT
	2	618119	9/16MJIC-90-9/16MOR LBO
	2	920505	5/8 LOCK WASHER
NS	1	621517	REPAIR KIT, HYD CYL 621516

NOTE: 1. 621205 - RH STEERING CYLINDER ASSEMBLY W/CYL SWIV DET.2
 2. 621206 - LH STEERING CYLINDER ASSEMBLY W/CYL SWIV DET.3

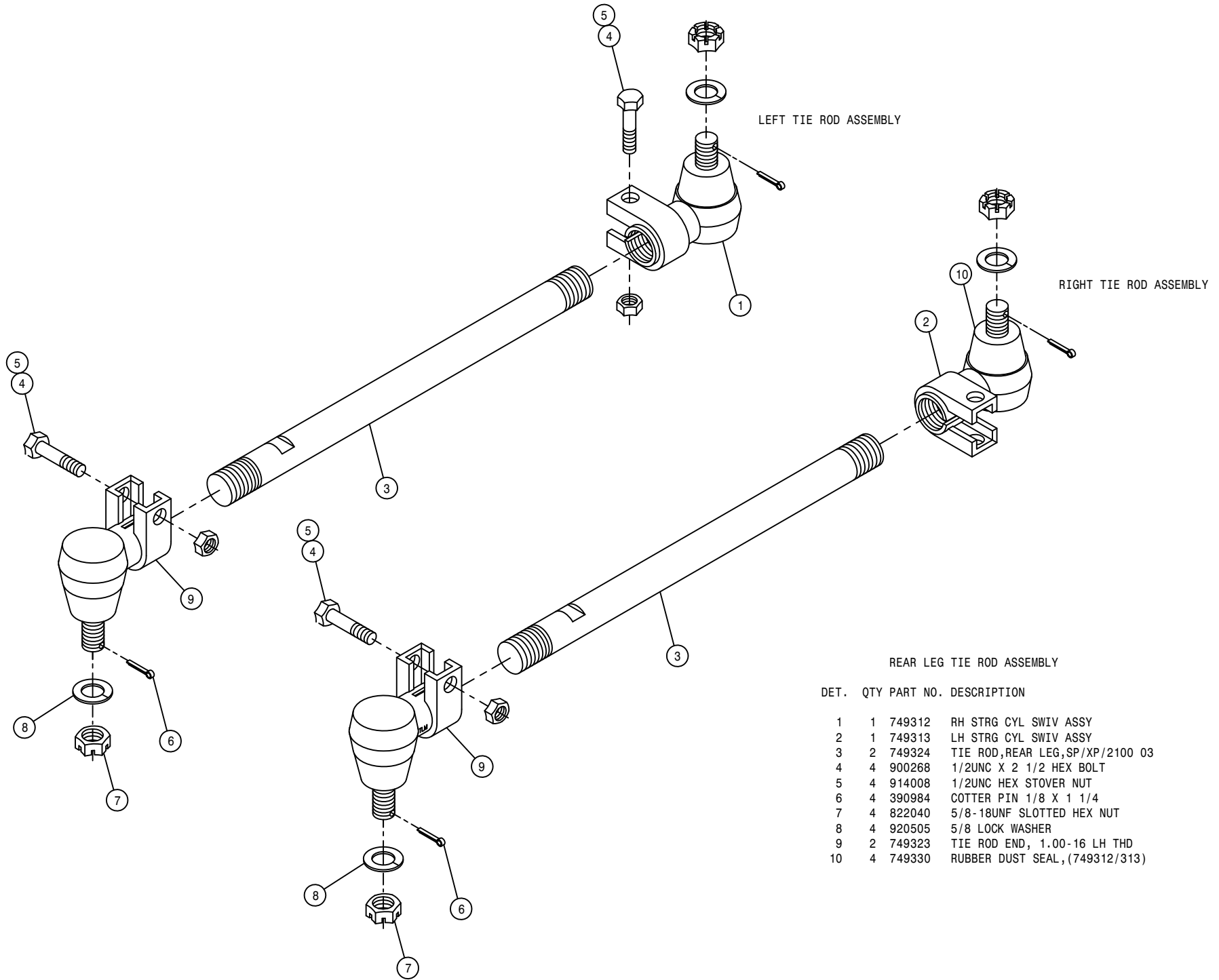

REAR LEG TIE ROD ASSEMBLY

DET.	QTY	PART NO.	DESCRIPTION
	1	749312	RH STRG CYL SWIV ASSY
	1	749313	LH STRG CYL SWIV ASSY
	2	749324	TIE ROD, REAR LEG, SP/XP/2100 03
	4	900268	1/2UNC X 2 1/2 HEX BOLT
	4	914008	1/2UNC HEX STOVER NUT
	4	390984	COTTER PIN 1/8 X 1 1/4
	4	822040	5/8-18UNF SLOTTED HEX NUT
	4	920505	5/8 LOCK WASHER
	2	749323	TIE ROD END, 1.00-16 LH THD
	4	749330	RUBBER DUST SEAL, (749312/313)

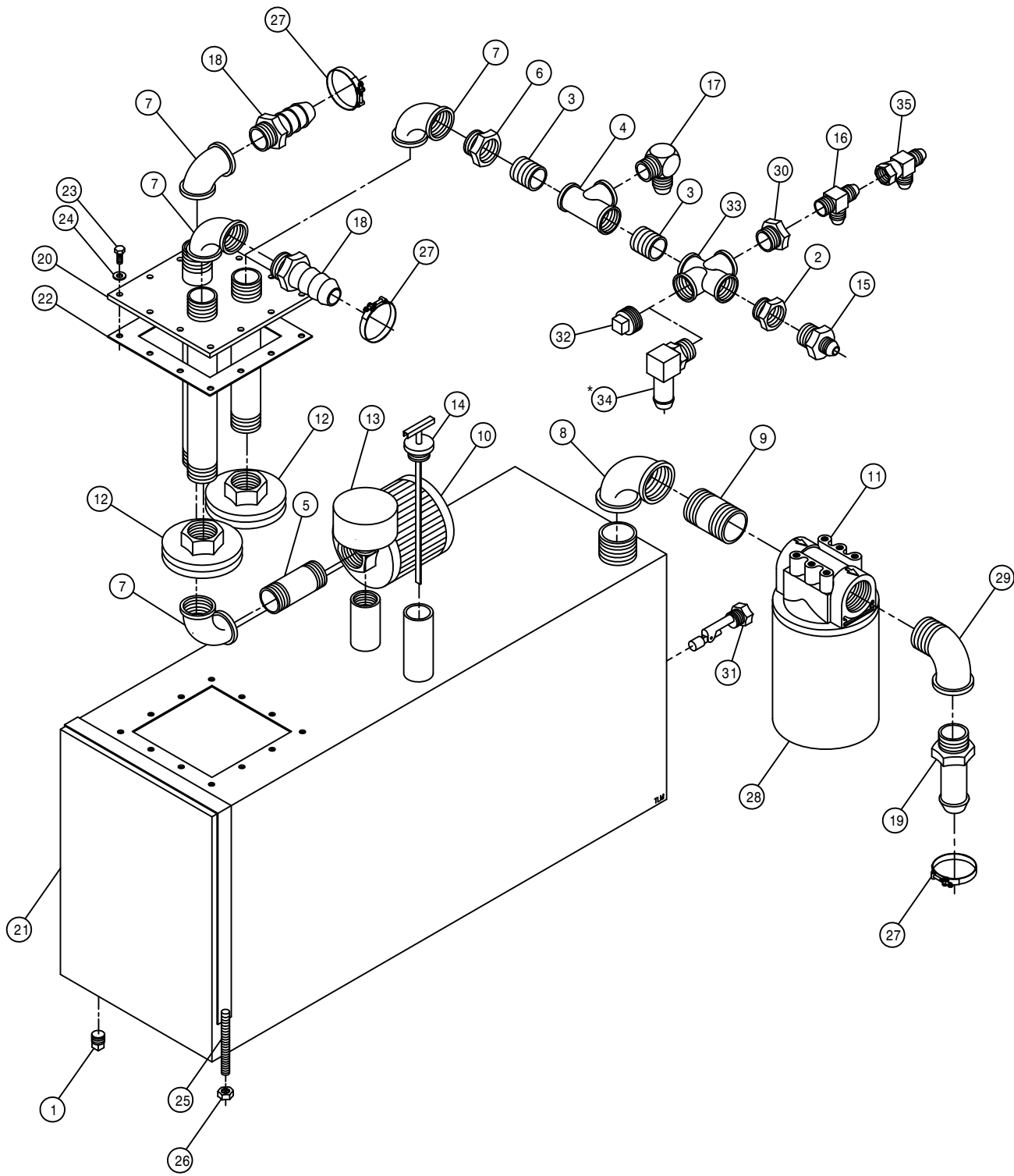

HYDRAULIC TANK ASSEMBLY

DET.	QTY	PART NO.	DESCRIPTION
1	1	470308	1/2MNPT DRAIN PLUG,AL HD,MAG
2	1	504210	RED BUSH 3/4 NPT X 1/2 NPT
3	2	504702	CLOSE NIPPLE .75NPT
4	1	504955	BLK PIPE TEE .75NPT
5	1	505203	BLK PIPE NIPPLE 1.00NPT-4.00
6	1	505213	RED BUSH 1 X 3/4 BLK MAL
7	4	505300	BLK PIPE EL 90DEG 1.00NPT
8	1	506303	BLK PIPE EL 90DEG 1.25NPT
9	1	506602	PIPE NIPPLE 1 1/4NPT-2 1/2
10	1	605600	TANK FILTER, 100 MESH,1"FNPT
11	1	605601	PARKER FILTER ASSY,10M,1.25NPT
12	2	605603	LINE SUMP DIFFUSER
13	1	611052	FILLER BREATHER 3/4NPT
14	1	614453	DIPSTICK, 8IN
15	1	618018	9/16MJIC-1/2MNPT ADPTR
16	1	618520	1/4MNPT RUN TEE-9/16MJIC
17	1	610305	3/4MJIC-90-3/4MNPT LBO
18	2	714560	1NPT X 1 HOSE BARB
19	1	715664	1 1/4 NPT X 1 HOSE BARB
20	1	760090	RECEIVER PLT WLD 8240
21	1	760264	HYD TANK WLD,204/254/284 2002
22	1	763039	HYD MTR MTG PLT GSKT
23	12	900064	5/16UNC X 3/4 HEX BOLT
24	12	920001	5/16 SAE FLAT WASHER
25	2	341360	OIL TANK STRAP WLD 8240 1982
26	4	914004	3/8UNC HEX STOVER NUT
27	3	520138	1.38/1.56 T-BOLT HOSE CLAMP
28	1	605602	PARKER FILTER ELEMENT,10MICRON
29	1	506410	BLK PIPE ST EL 90DEG 1.25NPT
30	1	504001	RED BUSH 3/4 X 1/4 BLK MAL
31	1	470350	LIQUID LEVEL SWITCH ASSY,1/2NP
32	1	504900	PIPE PLUG .75NPT SQ HD
33	1	504400	BLK PIPE CROSS .75NPT
34	1	618135	3/4 HOSE BARB-90-3/4MNPT
35	1	618486	9/16FJIC SW RUN TEE-9/16MJIC

*NOTE: DETAIL 34 IS USED WITH THE CUTTER OPTION.

FUEL TANK ASSEMBLY

DET. QTY PART NO. DESCRIPTION

DET.	QTY	PART NO.	DESCRIPTION
1	2	291428	FUEL SENDER 19 IN.
2	10	473902	NO 8 X 1/2 PAN HD MET SC
3	2	501102	1/4 PIPE PLUG
4	4	501451	BLK PIPE EL 90DEG .25NPT
5	2	760149	FUEL TANK WLD 200-280 90
6	2	761200	GAS CAP
7	2	783303	1/4 NPT X 5/16 HOSE BARB, BRS
8	2	601324	HOSE, 3/8 X 90 FUEL LINE
9	1	760153	RH FUEL TNK MT WLD 200-280 90
10	1	760154	LH FUEL TNK MT WLD 200-280 90
11	4	760162	FUEL TANK BAND WLD 200-280 90
12	1	610529	FUEL SELECTOR VALVE W/RETURN
13	1	610530	5 WIRE CONNECTOR FOR 610529
14	1	601421	HOSE, 5/16 X 50 FUEL LINE
15	8	914008	1/2UNC HEX STOVER NUT
16	2	601301	HOSE, 5/16 X 90 FUEL LINE
17	14	520120	HOSE CLAMP NO 4 STAINLESS
18	2	900064	5/16UNC X 3/4 HEX BOLT
19	4	914004	3/8UNC HEX STOVER NUT
20	8	900264	1/2UNC X 1 1/4 HEX BOLT
21	2	783304	1/4 NPT X 3/8 HOSE BARB, BRS
22	1	601322	HOSE, 3/8 X 26 FUEL LINE
23	2	316281	FUEL STRAINER, IN-LINE, DIESEL
24	2	601393	HOSE, 3/8 X 3 FUEL LINE
25	2	291464	GSKT FUEL SENDER, FOR 291428
26	4	470121	1/4UNC HEX FLANGE LOCK NUT

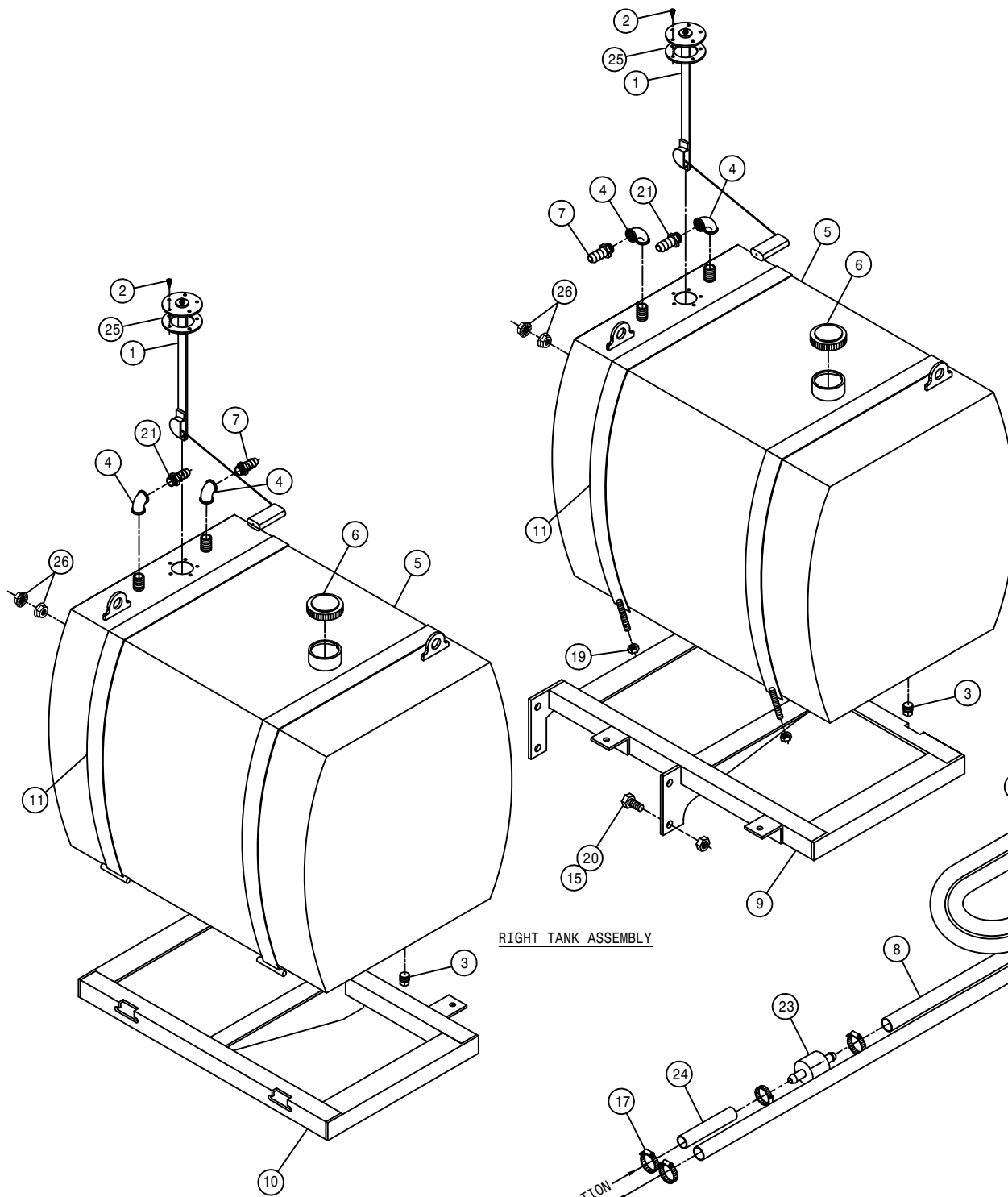

LEFT TANK ASSEMBLY

RIGHT TANK ASSEMBLY

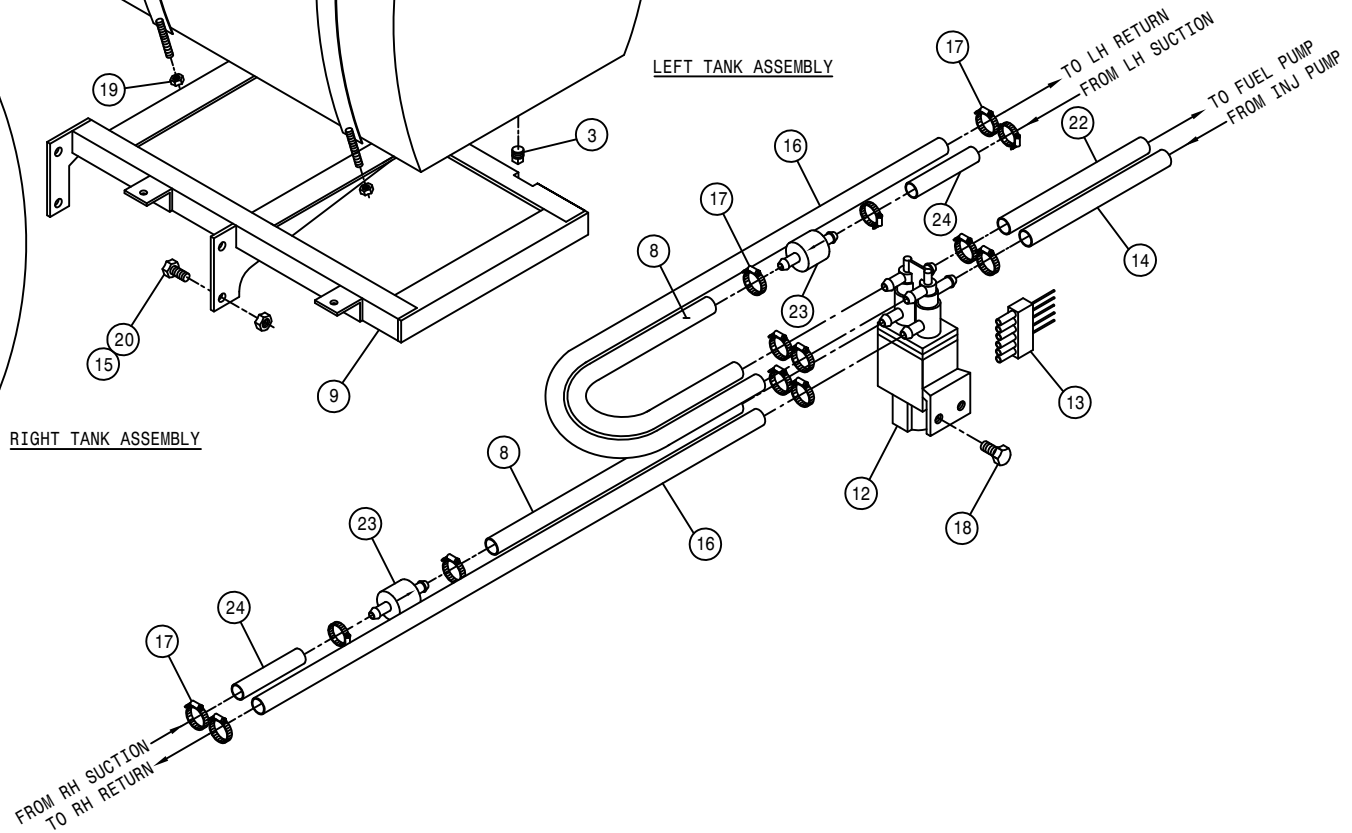

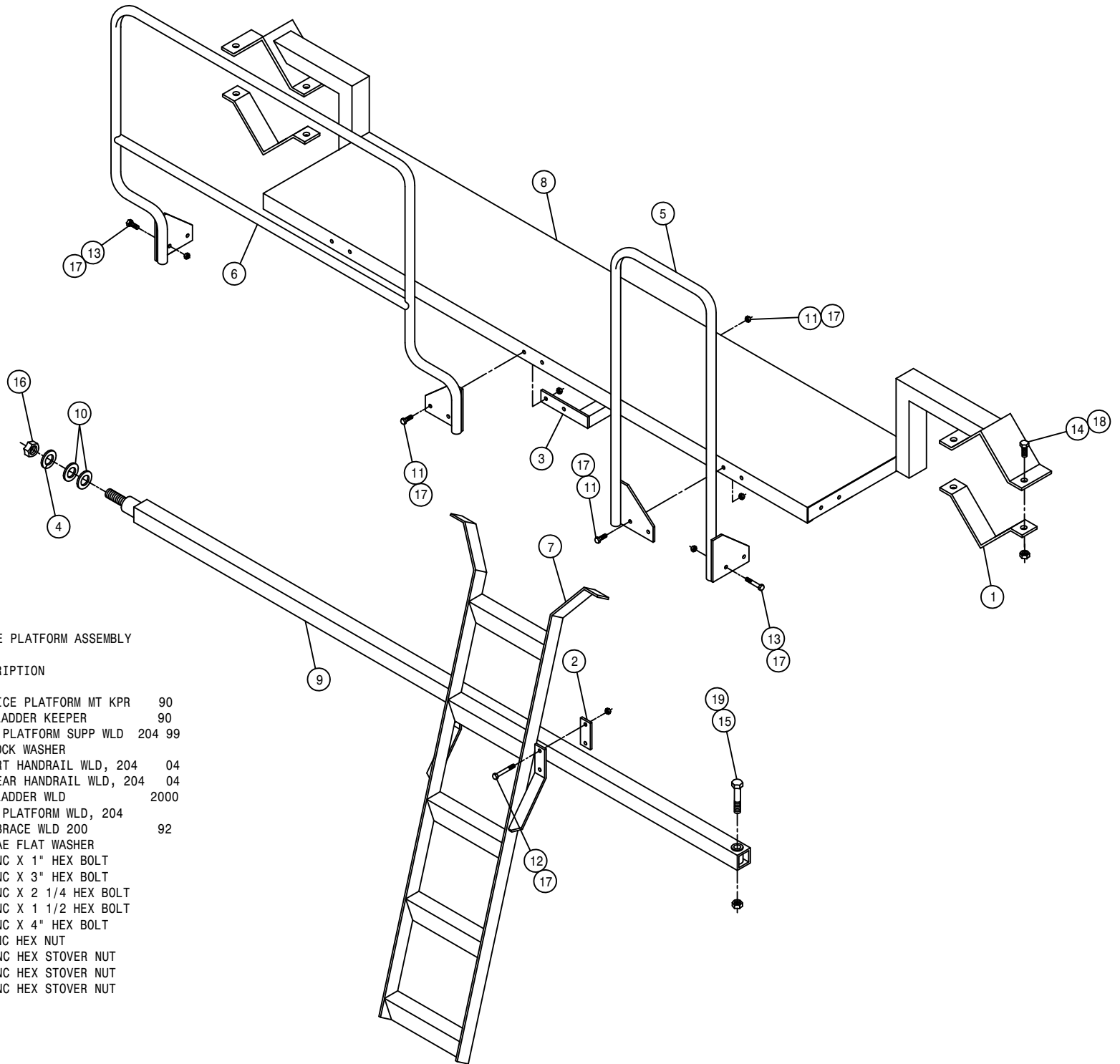

RH LADDER AND SERVICE PLATFORM ASSEMBLY

DET. QTY PART NO. DESCRIPTION

1	2	341900	SERVICE PLATFORM MT KPR	90
2	2	341912	200 LADDER KEEPER	90
3	1	342673	SERV PLATFORM SUPP WLD	204 99
4	1	920508	1" LOCK WASHER	
5	1	342974	RH FRT HANDRAIL WLD, 204	04
6	1	342977	RH REAR HANDRAIL WLD, 204	04
7	1	342700	204 LADDER WLD	2000
8	1	342007	SERV PLATFORM WLD, 204	
9	1	358673	LEG BRACE WLD 200	92
10	2	920008	1" SAE FLAT WASHER	
11	5	900129	3/8UNC X 1" HEX BOLT	
12	4	900136	3/8UNC X 3" HEX BOLT	
13	4	900170	3/8UNC X 2 1/4 HEX BOLT	
14	4	900265	1/2UNC X 1 1/2 HEX BOLT	
15	1	900410	3/4UNC X 4" HEX BOLT	
16	1	910017	1" UNC HEX NUT	
17	13	914004	3/8UNC HEX STOVER NUT	
18	4	914008	1/2UNC HEX STOVER NUT	
19	1	914012	3/4UNC HEX STOVER NUT	

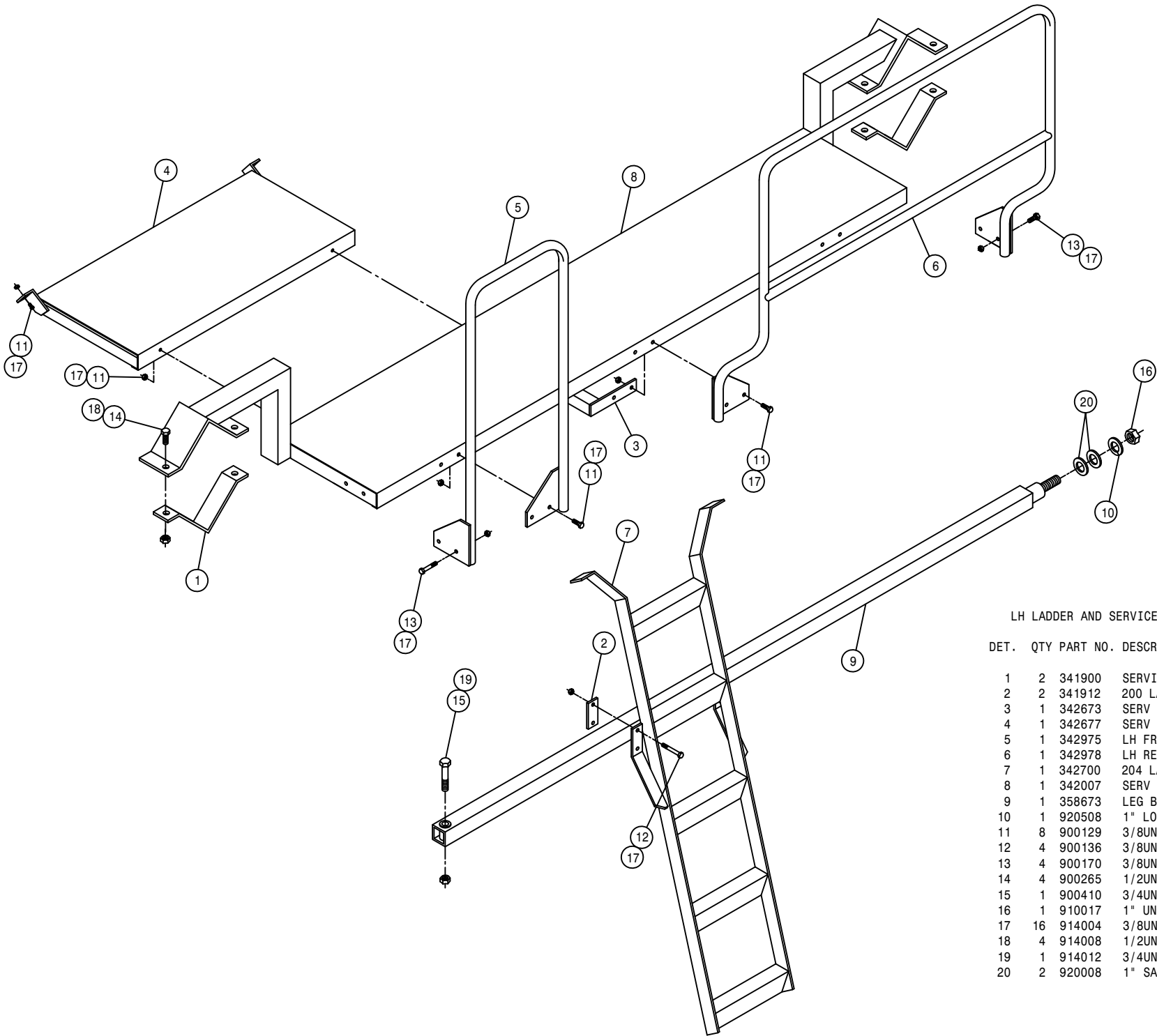

LH LADDER AND SERVICE PLATFORM ASSEMBLY

DET.	QTY	PART NO.	DESCRIPTION	
1	2	341900	SERVICE PLATFORM MT KPR	90
2	2	341912	200 LADDER KEEPER	90
3	1	342673	SERV PLATFORM SUPP WLD	204 99
4	1	342677	SERV PLATFORM STEP WLD	204 99
5	1	342975	LH FRT HANDRAIL WLD, 204	04
6	1	342978	LH REAR HANDRAIL WLD, 204	04
7	1	342700	204 LADDER WLD	2000
8	1	342007	SERV PLATFORM WLD, 204	
9	1	358673	LEG BRACE WLD 200	92
10	1	920508	1" LOCK WASHER	
11	8	900129	3/8UNC X 1" HEX BOLT	
12	4	900136	3/8UNC X 3" HEX BOLT	
13	4	900170	3/8UNC X 2 1/4 HEX BOLT	
14	4	900265	1/2UNC X 1 1/2 HEX BOLT	
15	1	900410	3/4UNC X 4" HEX BOLT	
16	1	910017	1" UNC HEX NUT	
17	16	914004	3/8UNC HEX STOVER NUT	
18	4	914008	1/2UNC HEX STOVER NUT	
19	1	914012	3/4UNC HEX STOVER NUT	
20	2	920008	1" SAE FLAT WASHER	

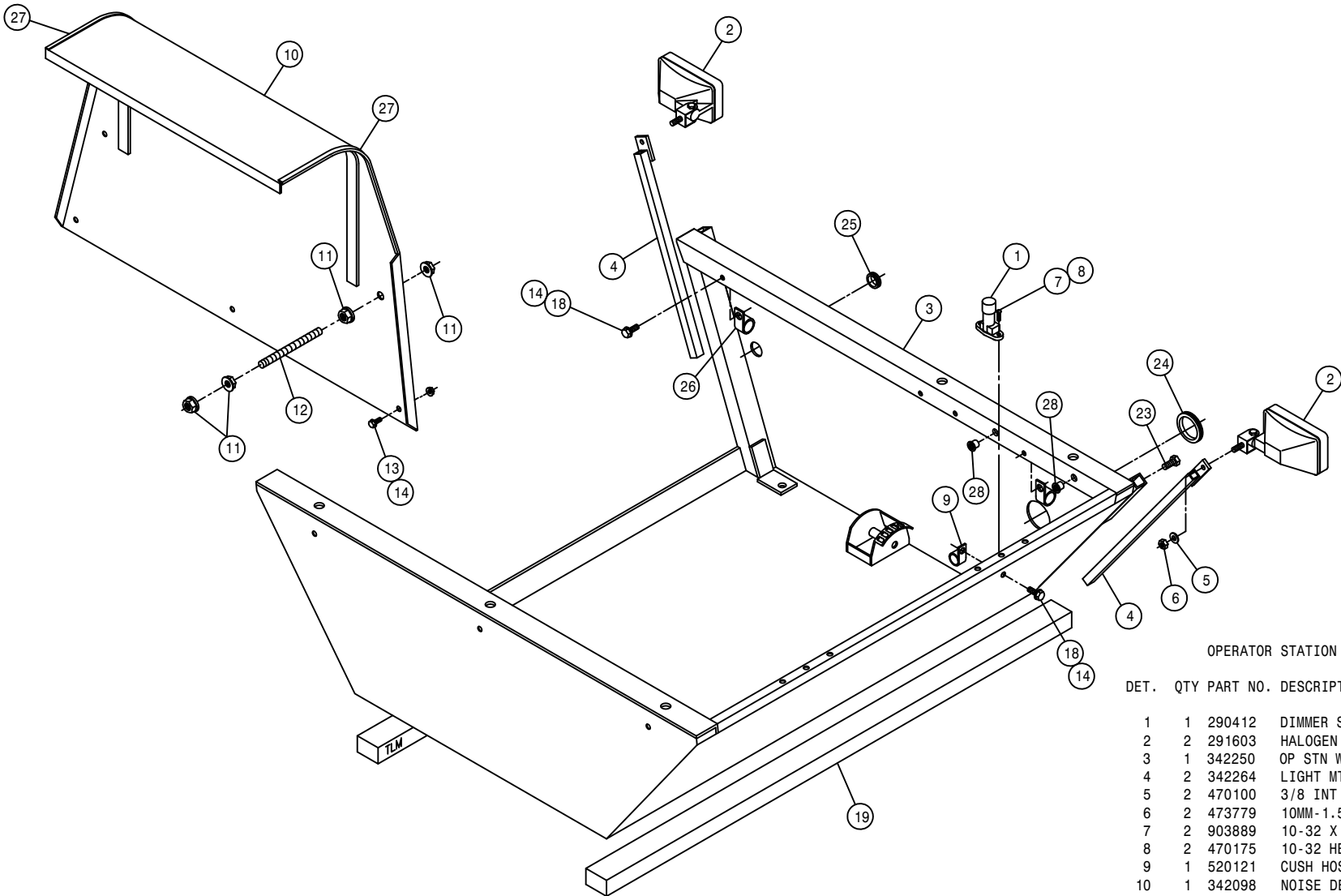

OPERATOR STATION ASSEMBLY

DET.	QTY	PART NO.	DESCRIPTION
	1	290412	DIMMER SWITCH
	2	291603	HALOGEN WORKLAMP, SIDE MT 12V
	3	342250	OP STN WLD, 204 94
	4	342264	LIGHT MT WLD, 204 94
	5	470100	3/8 INT TOOTH LOCK WASHER
	6	473779	10MM-1.50 HEX NUT
	7	903889	10-32 X 3/4 SLT RDHD MACH SCR
	8	470175	10-32 HEX FLANGE LOCK NUT
	9	520121	CUSH HOSE CLAMP 1IN X 3/4W
	10	342098	NOISE DEFLECTOR WELDMT 204
	11	470087	3/8UNC HEX FLANGE LOCK NUT
	12	314929	3/8UNC X 3.00 STUD BOLT, FULL
	13	470122	1/4UNC X 1/2 FLANGE HEX BOLT
	14	470121	1/4UNC HEX FLANGE LOCK NUT
	15	290107	GROUND CABLE, 8" X 4GA .406LUGS
	16	311051	RUBBER MOUNT, RB3-350
	17	311052	SNUBBING WASHER FOR 311051
	18	470118	1/4UNC X 3/4 FLANGE HEX BOLT
	19	659704	FOAM, 2" THK X 2" WIDE X 42" LG
	20	900342	5/8UNC X 4" HEX BOLT
	21	914010	5/8UNC HEX STOVER NUT
	22	914004	3/8UNC HEX STOVER NUT
	23	900128	3/8UNC X 3/4 HEX BOLT
	24	1473915	GROMMET, 1.500ID .062GW 1.750GD
	25	1470067	GROMMET, .250ID .125GW .375GD
	26	520118	CUSH HOSE CLAMP 1/2D X 1/2W
	27	193011	EDGE GUARD, BLK
	28	470380	1/4-20 NUTSERT .027-.165 STL

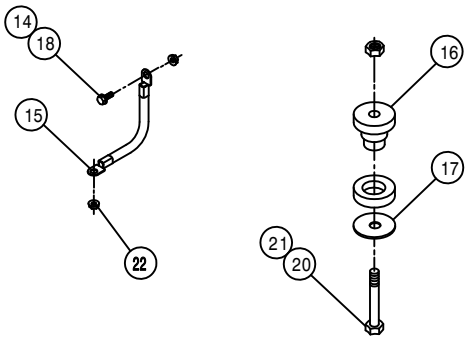

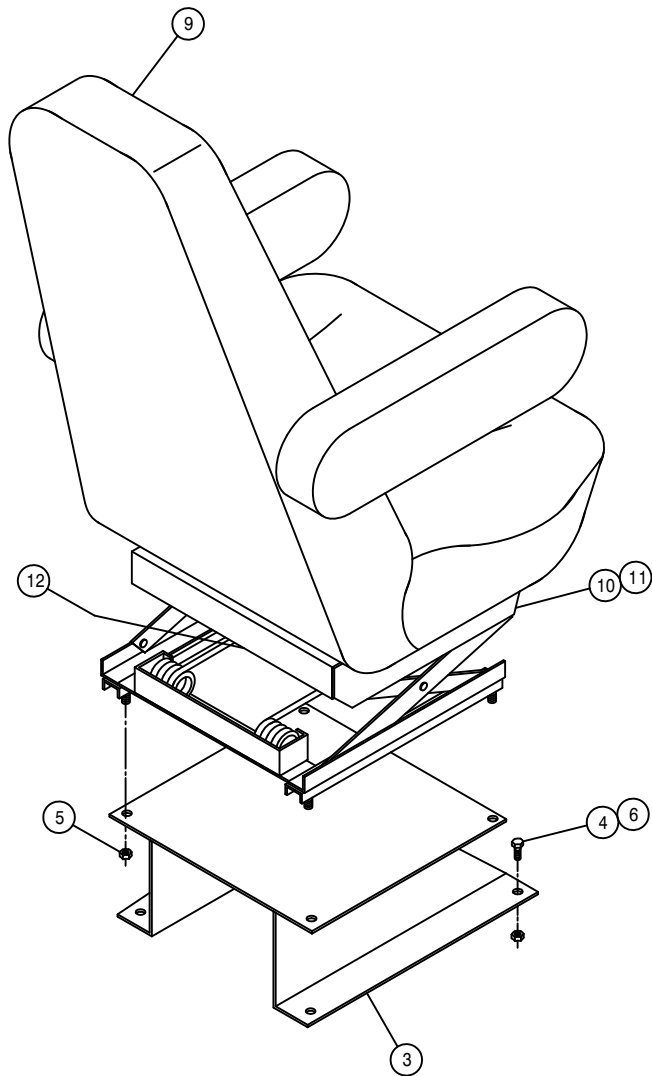

SEAT ASSEMBLY W/CAB

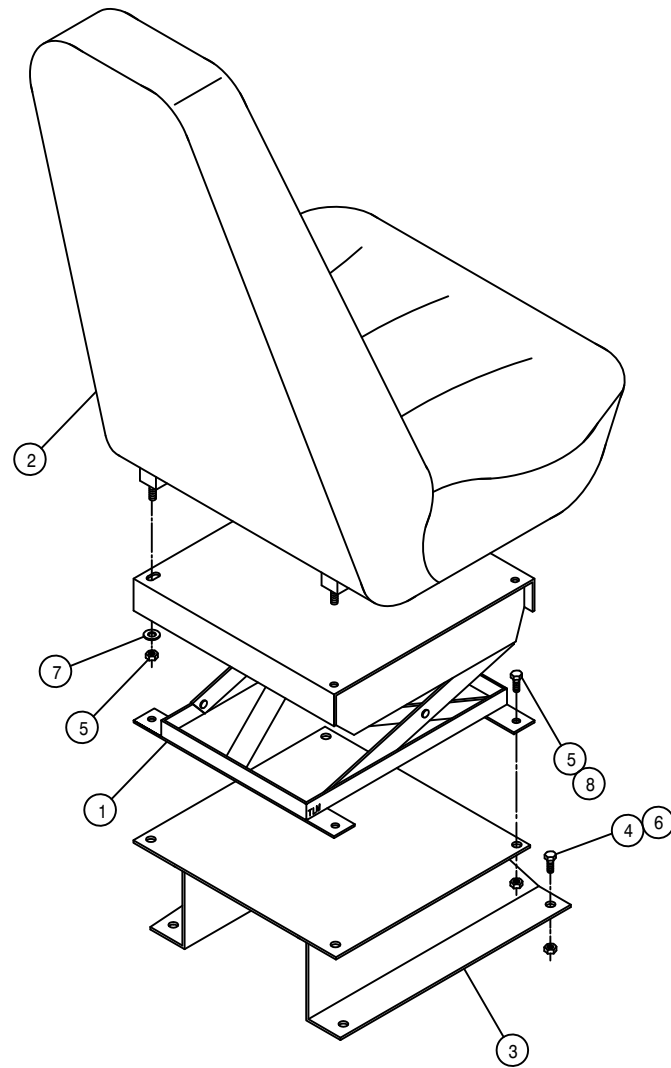

SEAT ASSEMBLY W/O CAB

SEAT ASSEMBLY

DET. QTY PART NO. DESCRIPTION

1	1	330015	SUSPENSION ASSY TRIMLINE SEAT
2	1	330017	TRIMLINE SEAT, MID HIGH,VINYL
3	2	341554	SEAT MT WLD TRIMLINE SEAT
4	8	900129	3/8UNC X 1" HEX BOLT
5	12	914002	5/16UNC HEX STOVER NUT
6	8	914004	3/8UNC HEX STOVER NUT
7	2	920001	5/16 SAE FLAT WASHER
8	4	900064	5/16UNC X 3/4 HEX BOLT
9	1	330022	SEAT,MAGNUM-100 AIR SUSPEND95
10	1	330024	HEIGHT ADJ LATCH, SEAT 330022
11	1	330025	ADJ LATCH SPRING, SEAT 330022
12	1	330023	AIR BAG PKG, SEAT 330022

INSTRUMENT PANEL ASSEMBLY

DET. QTY PART NO. DESCRIPTION

1	1	290401	FUEL GAUGE FOR 2.125 DIA HOLE
2	1	291203	HOUR METER, 12/24VDC BLACK BEZ
3	1	291609	OIL PRESS GAUGE, 80PSI
4	1	291611	VOLTMETER, 8V TO 18V DC
5	4	291612	LIGHT KIT FOR 2" GAUGE
6	1	291641	DIGITAL MPH/RPM INDICATOR W/P
7	1	314436	TEMP GA 100-280 DEG LIGHTED
8	1	342068	DIGITAL MPH/RPM IND KEEPER 94
9	1	342232	INSTRUMENT PANEL, 204 94
10	1	342233	INSTRUMENT HSG WLD, 204 94
11	1	390318	INDICATOR LIGHT, RED
12	1	470204	GROMMET, 1.000ID .125GW 1.375GD
13	1	470224	SNAP PLUG, BLK NYL, .50 DIA
14	2	900263	1/2UNC X 1" HEX BOLT
15	2	193011	EDGE GUARD, BLK
16	4	903710	10-32X5/8 PHIL PANHD MACH SCR
17	2	920504	1/2 LOCK WASHER
18	1	314901	FILTER MINDER AIR RESTRICT GA
19	4	470165	10-32 NUTSERT .020-.100 MATL

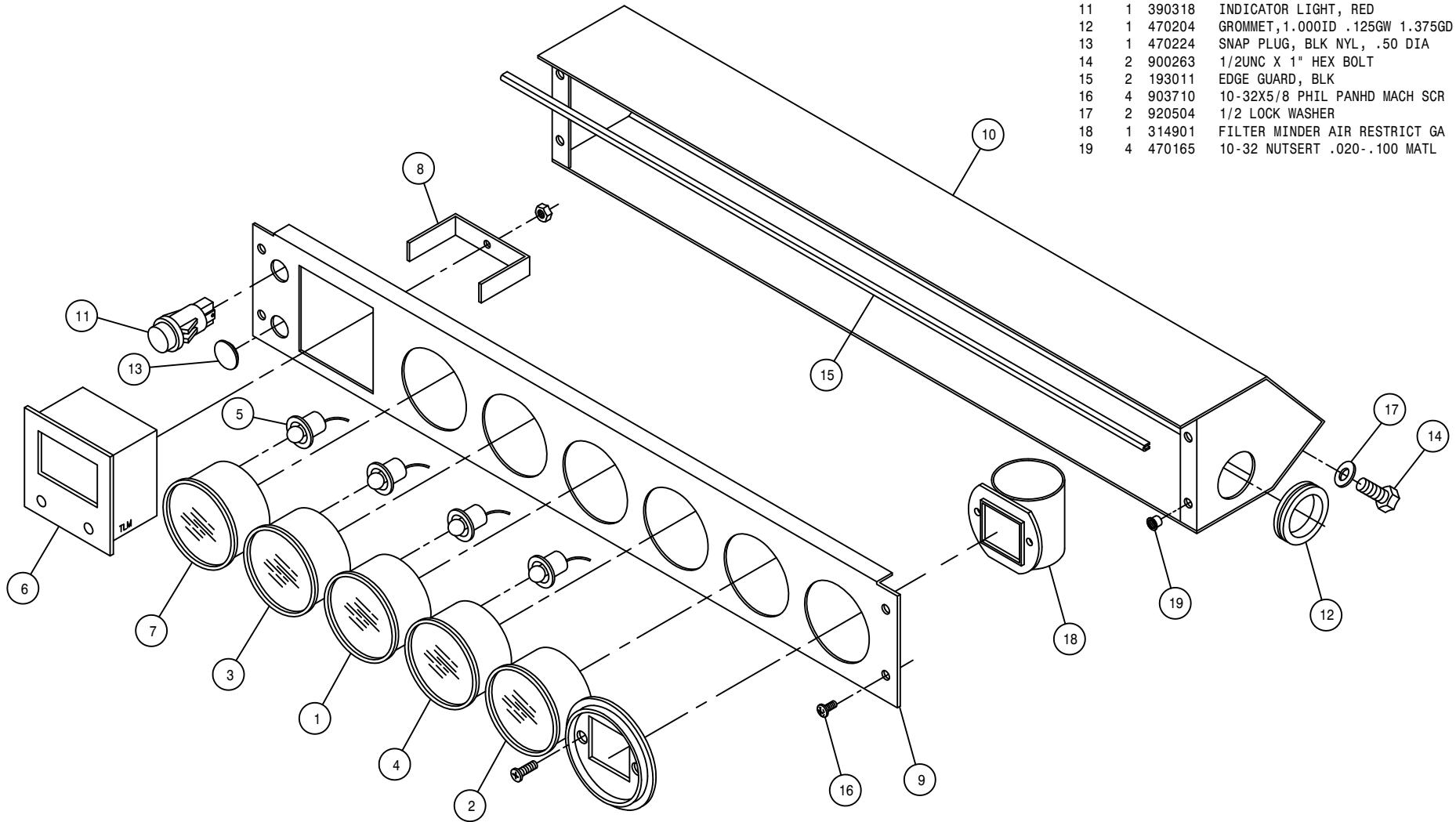

STEERING POST ASSEMBLY

DET. QTY PART NO. DESCRIPTION

DET.	QTY	PART NO.	DESCRIPTION
1	1	221001	CONN LINK CLIP TYPE RC50
2	1	291088	FLASHER / TURN SIGNAL SWITCH
3	1	342165	STRG POST WLD, 284 CAB 94
4	1	342173	STRG POST ADJ PIN, 284 CAB 94
5	1	342174	STRG POST ADJ PIN LEVER WLD94
6	1	342177	STRG POST COVER, 284 CAB 94
7	1	342178	UPR STRG MTR HSNG COVER 94
8	1	342179	LWR STRG MTR HSNG COVER 94
9	2	390318	INDICATOR LIGHT, RED
10	4	470380	1/4-20 NUTSERT .027-.165 STL
11	1	470157	13/16-20UNEF HEX NUT STRG WHL
12	1	473939	ROLL PIN, 3/16DIA X 7/8
13	1	659291	KNOB, 1" RND, BLK, 3/8-16
14	1	749318	STRG MTR, 7.3CID, NON-LOAD 1031
15	1	749178	STRG COLUMN 2.5IN LONG
16	1	749245	STRG WHL 14.0 DIA
17	1	749244	STRG WHL CAP FOR 749245
18	13	903708	1/4UNC X 1/2 PHIL PNHD MACHSCR
19	1	914002	5/16UNC HEX STOVER NUT
20	1	914008	1/2UNC HEX STOVER NUT
21	1	900271	1/2UNC X 3 1/4 HEX BOLT
22	4	920001	5/16 SAE FLAT WASHER
23	4	920002	3/8 SAE FLAT WASHER
24	4	900130	3/8UNC X 1 1/4 HEX BOLT
25	4	618496	9/16MJIC-45-3/4MOR LBO
26	1	482131	3/4 X 1 3/4 COMPRSN SPRING
27	1	470121	1/4UNC HEX FLANGE LOCK NUT

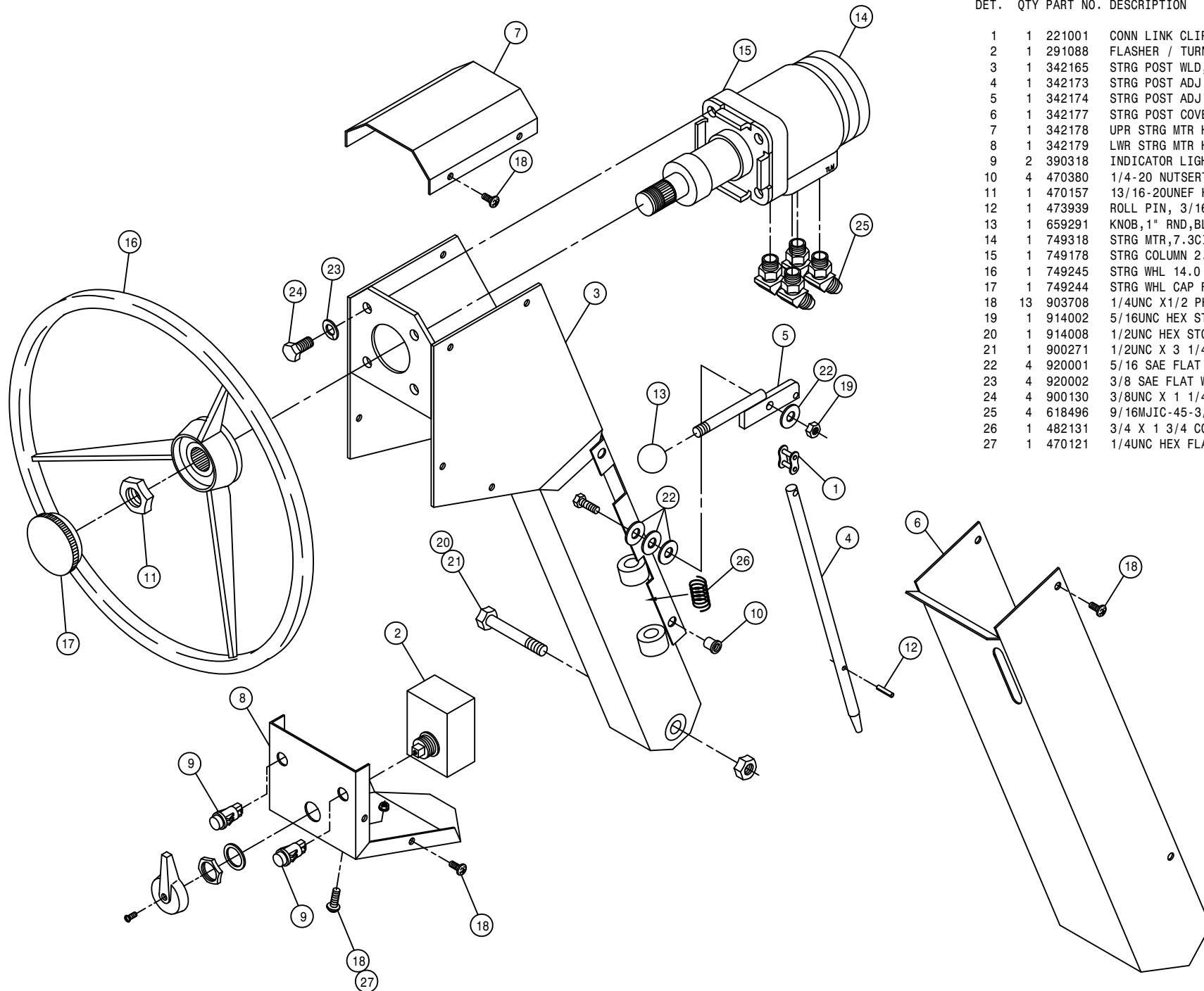

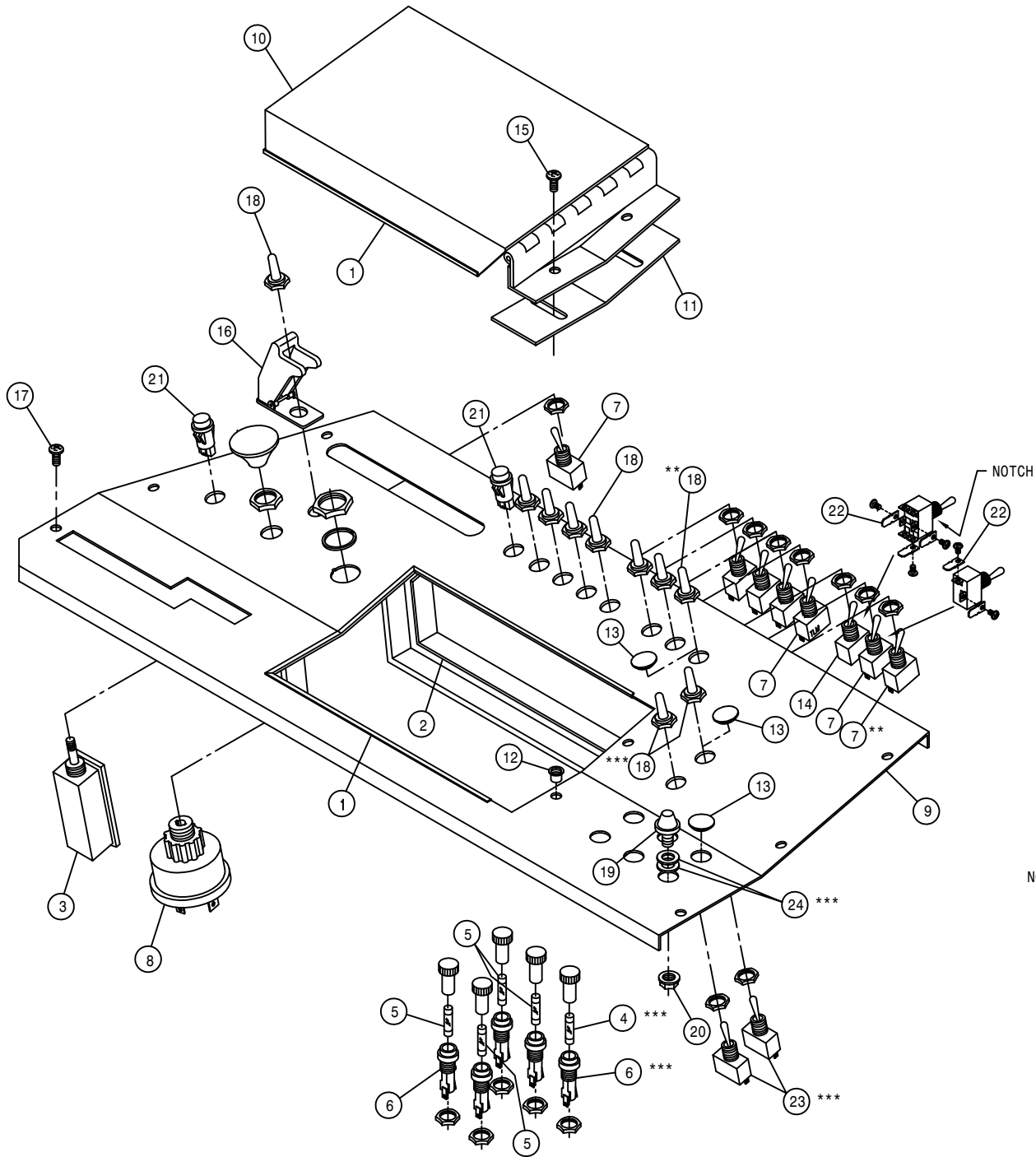

CONSOLE PANEL ASSEMBLY

DET. QTY PART NO. DESCRIPTION

1	2	193011	EDGE GUARD, BLK
2	2	193037	STICKERTITE 1/8 X 3/4
3	1	290046	LIGHT SWITCH TWO POSITION
4	2	291602	FUSE 10 AMP
5	4	298004	20 AMP FUSE SFE 20
6	5	298011	FUSE HOLDER
7	7	298012	TOGGLE SWITCH, ON-OFF, SPST, 15A
8	1	321020	IGN SWITCH, SEALED, 4 TERMINAL
9	1	342237	CONSOLE PANEL WLD, 204 94
10	1	342240	CONTROL BOX COVER WLD, 204 94
11	1	342244	CONTROL BOX KEEPER, 204 94
12	2	470165	10-32 NUTSERT .020-.100 MATL
13	4	470224	SNAP PLUG, BLK NYL, .50 DIA
14	1	610412	TOGGLE SWITCH FOR FUEL VLV
15	2	903710	10-32X5/8 PHIL PANHD MACH SCR
16	1	291655	AIRCRAFT TOGGLE SWITCH GUARD
17	6	903708	1/4UNC X1/2 PHIL PNHD MACHSCR
18	10	470001	RUBBER BOOT W NUT FOR 298012
19	1	470230	1/2 RUBBER BUMPER, 1/4-20 STUD
20	1	470121	1/4UNC HEX FLANGE LOCK NUT
21	2	390318	INDICATOR LIGHT, RED
22	6	291644	.250MALE FASTON-#6 RING ADAPT
23	2	293038	TOGGLE SWITCH DPDT 15 AMP
24	2	920002	3/8 SAE FLAT WASHER

NOTE: ITEMS WITH (**) ARE USED WITH THE WINDSHIELD WIPER IN THE CAB OPTION.

ITEMS WITH (***) ARE USED WITH THE OUTRIGGER FOLD OPTION.

CONSOLE ASSEMBLY

DET. QTY PART NO. DESCRIPTION

1	1	293093	TERMINAL BLOCK 6 POS - 2 ROW
2	1	342248	CONSOLE BRACE, 204 94
3	1	342216	DRINK HOLDER MT BRKT 94
4	6	470380	1/4-20 NUTSERT .027-.165 STL
5	4	470175	10-32 HEX FLANGE LOCK NUT
6	1	470214	SPILLMASTER DRINK HOLDER
7	1	291197	CIRCUIT BREAKER,30AMP,INLINEMT
8	1	342245	CONSOLE WLD, 204 94
9	1	291024	CIRCUIT BREAKER,40AMP,INLINEMT
10	4	470121	1/4UNC HEX FLANGE LOCK NUT
11	3	470118	1/4UNC X 3/4 FLANGE HEX BOLT
12	4	903710	10-32X5/8 PHIL PANHD MACH SCR
13	4	903812	6-32 X 1/2 SLT RD HD MACH SCR
14	2	903814	6-32 X 3/4 SLT RD HD MACH SCR
15	6	910022	6-32 HEX NUT
16	1	910024	8-32 HEX NUT
17	1	470231	1/4UNC X 1" FLANGE HEX BOLT
18	1	291640	RELAY, 12V 20/30AMP BOSCH
19	1	903844	8-32 X 1/2 SLT RD HD MACH SCR

NOTE: 1. ITEMS MARKED WITH A (*) ARE USED WITH THE CAB OPTION.

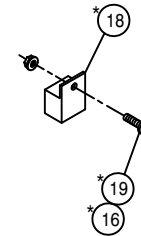
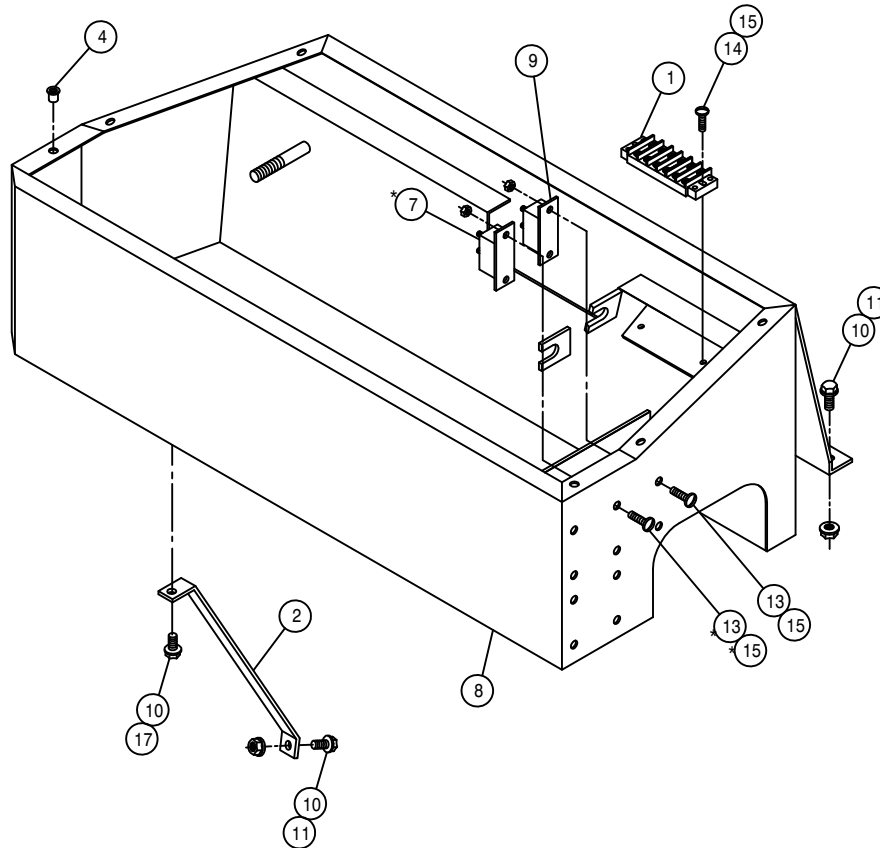
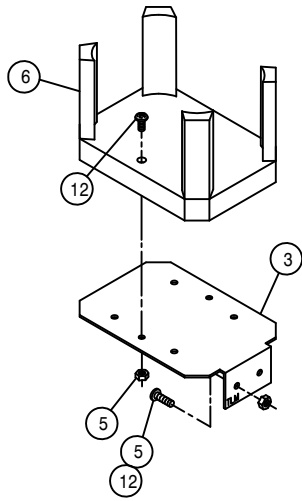

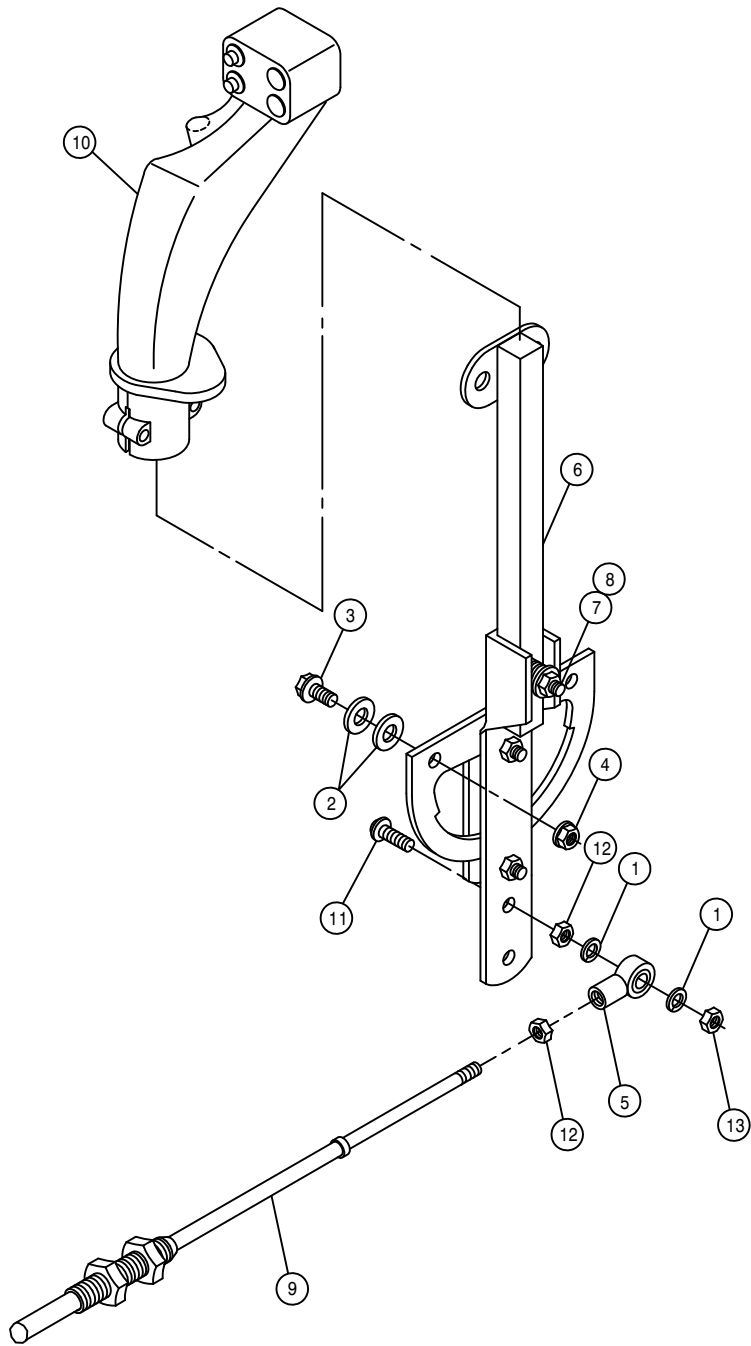

HYDROSTATIC LEVER ASSEMBLY

DET. QTY PART NO. DESCRIPTION

DET.	QTY	PART NO.	DESCRIPTION
1	2	920510	#10 LOCK WASHER
2	4	920000	1/4 SAE FLAT WASHER
3	2	470118	1/4UNC X 3/4 FLANGE HEX BOLT
4	2	470121	1/4UNC HEX FLANGE LOCK NUT
5	1	473921	BALL JOINT NO 10-32 THD
6	1	606907	HYDST CTRL LEVER ASSY 204-284
7	1	900005	1/4UNC X 1 1/2 HEX BOLT
8	1	914000	1/4UNC HEX STOVER NUT
9	1	785003	CTRL CABLE 10-32 4IN X 112 LG
10	1	785077	FASSE EZ-3 CONTROL HANDLE,204
11	1	903893	10-32 X 1" SLT RD HD MACH SCR
12	2	910027	10-32 HEX NUT
13	1	914027	10-32 HEX STOVER NUT

THROTTLE LEVER ASSEMBLY

DET. QTY PART NO. DESCRIPTION

1	1	499001	SPRING HYDRO CONTROL
2	1	785007	KNOB, 1 3/16" BALL, RED, 3/8-16
3	1	785046	FRICTION DISC 3-333 X .38
4	1	785066	CTRL CABLE 10-32 4IN X 129 IN
5	1	785067	THROT LEVER WLD, GAS/DIESEL 94
6	1	903893	10-32 X 1" SLT RD HD MACH SCR
7	2	910027	10-32 HEX NUT
8	1	914004	3/8UNC HEX STOVER NUT
9	1	914027	10-32 HEX STOVER NUT
10	1	920002	3/8 SAE FLAT WASHER
11	2	920510	#10 LOCK WASHER
12	1	473921	BALL JOINT NO 10-32 THD

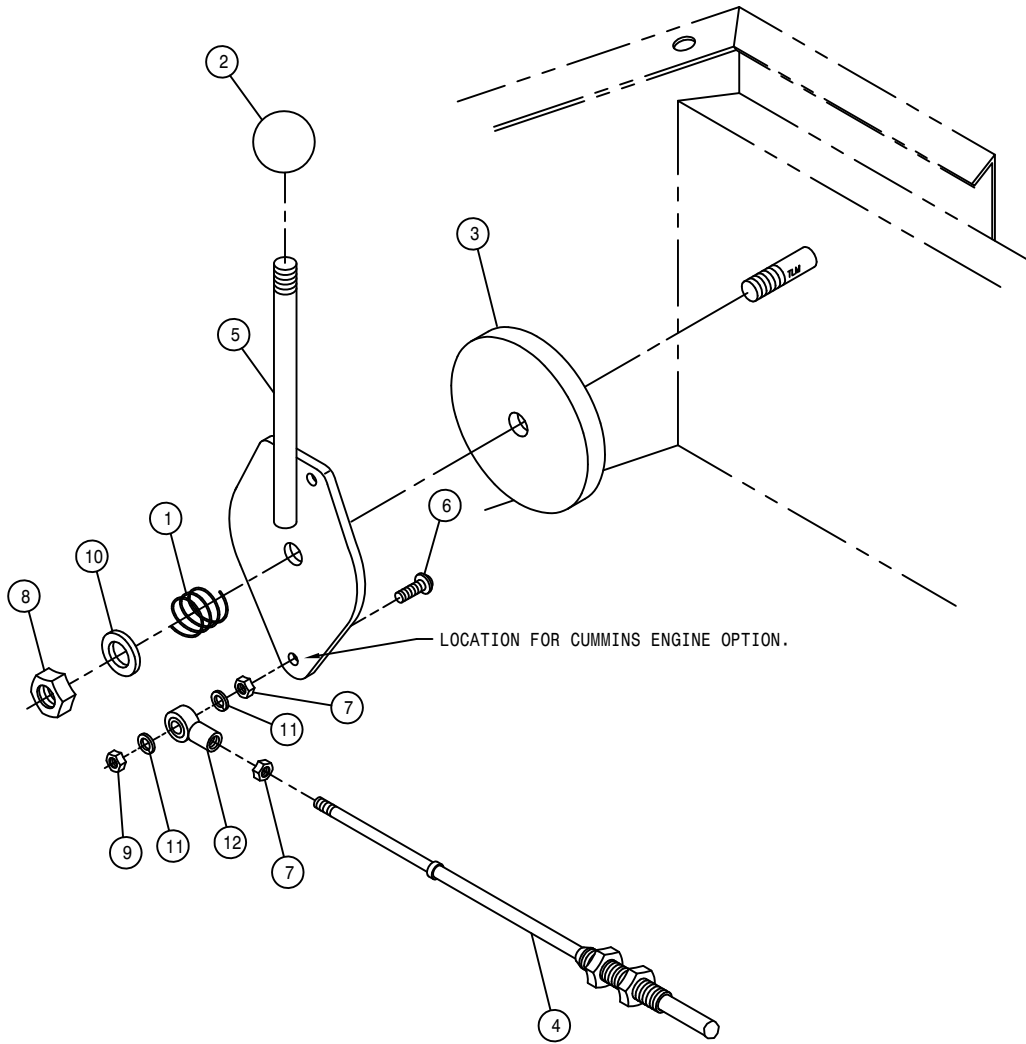

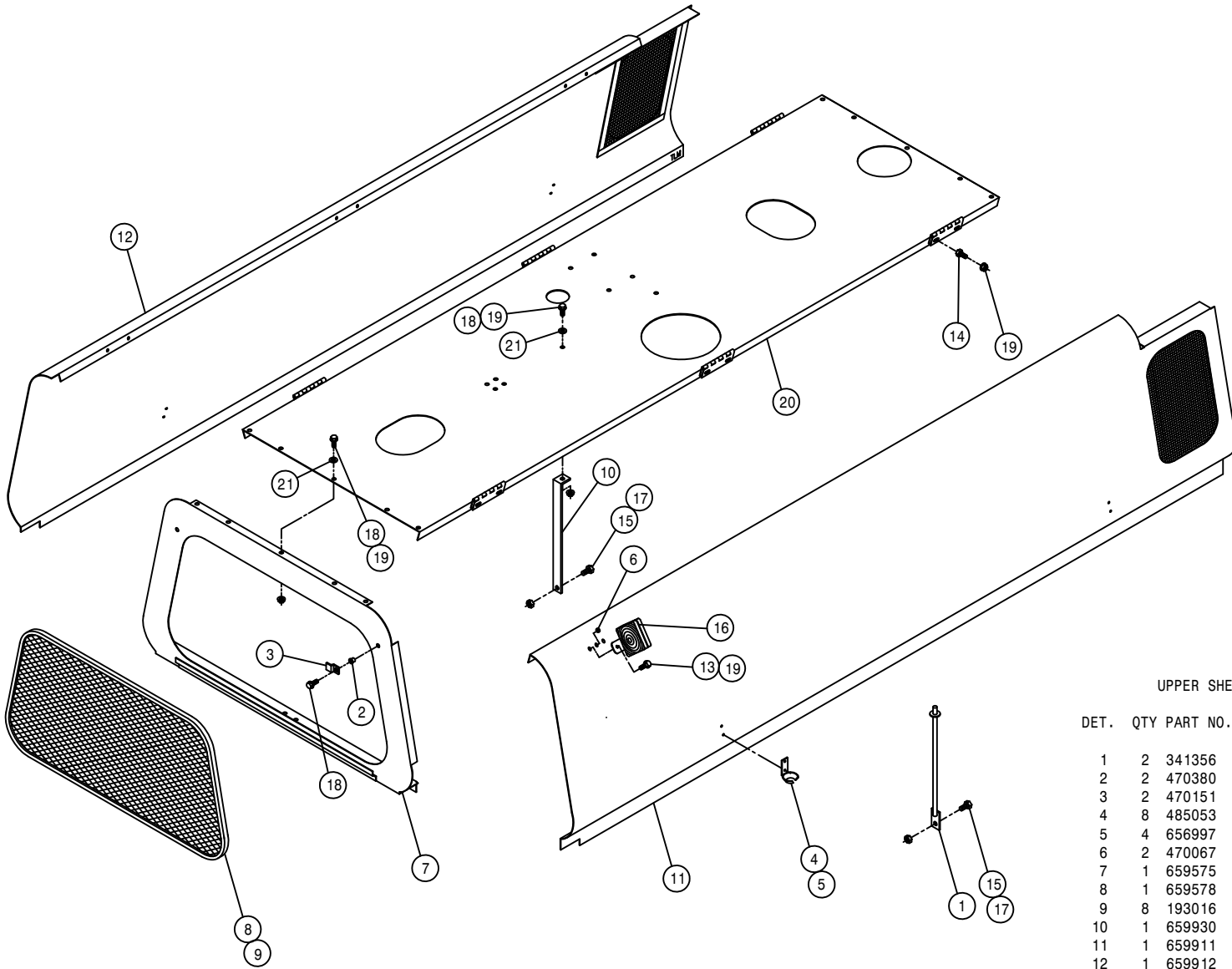

UPPER SHEET METAL ASSEMBLY

DET.	QTY	PART NO.	DESCRIPTION
	1	2	341356 ENGINE HOOD PROP WLD 8240 82
	2	2	470380 1/4-20 NUTSERT .027-.165 STL
	3	2	470151 UPPER REAR PANEL SCREEN CLIP
	4	8	485053 POP RIVET 3/16 X 3/8
	5	4	656997 RUBBER HOOK BRKT
	6	2	470067 GROMMET, .250ID .125GW .375GD
	7	1	659575 UPPER REAR PANEL WLD 8240 82
	8	1	659578 UPPER REAR PANEL SCREEN 8240
	9	8	193016 QUICKEDGE TRIM .060 TO .170
	10	1	659930 MULLION SUPPORT BRKT, 284 97
	11	1	659911 RH ENG HOOD WLD, 204 94
	12	1	659912 LH ENG HOOD WLD, 204 94
	13	4	470122 1/4UNC X 1/2 FLANGE HEX BOLT
	14	12	900000 1/4UNC X 1/2 HEX BOLT
	15	3	900128 3/8UNC X 3/4 HEX BOLT
	16	2	291604 TURN SIGNAL LIGHT,PED MT, YEL
	17	3	914004 3/8UNC HEX STOVER NUT
	18	13	470118 1/4UNC X 3/4 FLANGE HEX BOLT
	19	27	470121 1/4UNC HEX FLANGE LOCK NUT
	20	1	660234 MULLION WLD, 204/284 CUMM 04
	21	11	470212 1/4 BONDED SEALING WASH, SS

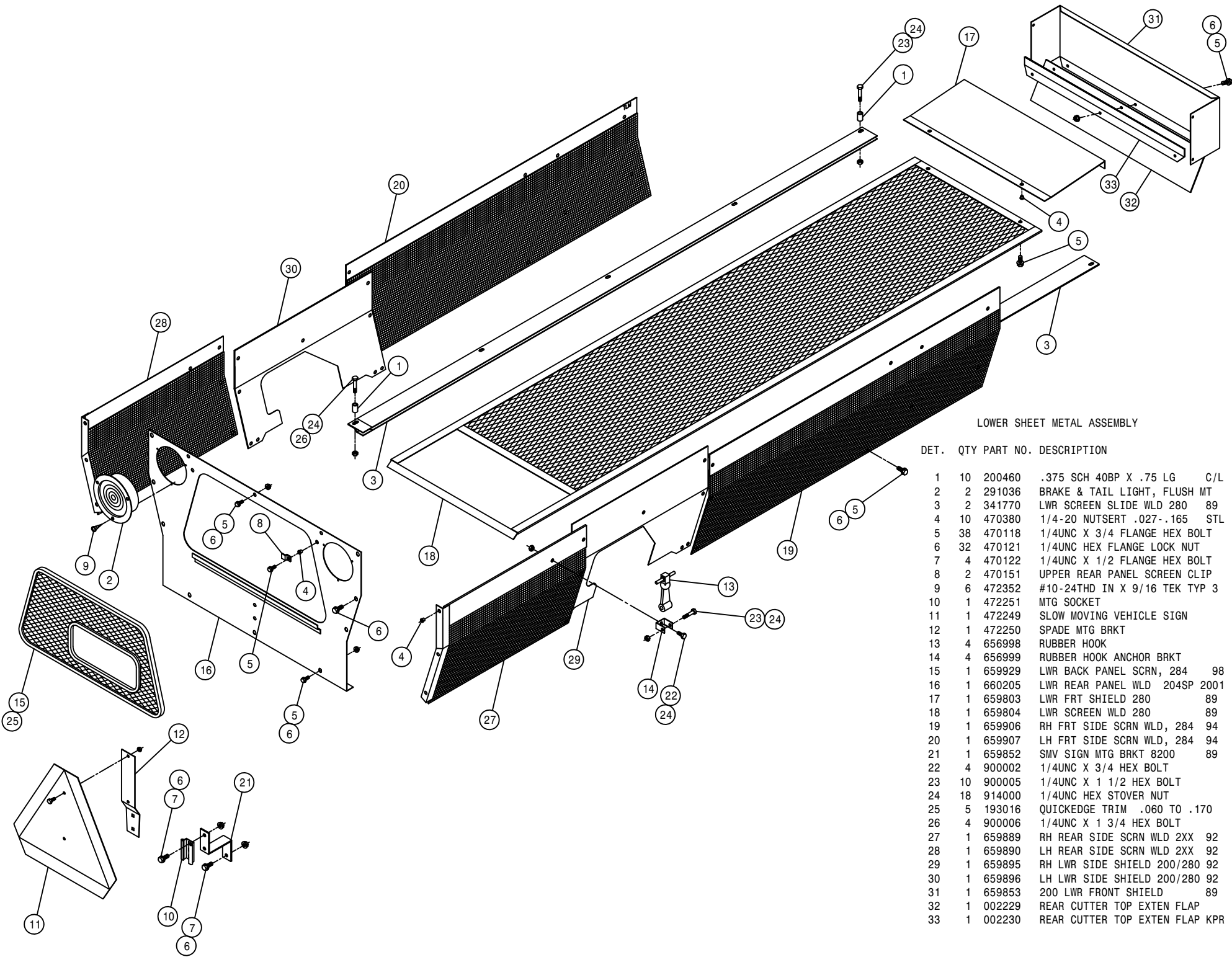

LOWER SHEET METAL ASSEMBLY

DET.	QTY	PART NO.	DESCRIPTION
1	10	200460	.375 SCH 40BP X .75 LG C/L
2	2	291036	BRAKE & TAIL LIGHT, FLUSH MT
3	2	341770	LWR SCREEN SLIDE WLD 280 89
4	10	470380	1/4-20 NUTSERT .027-.165 STL
5	38	470118	1/4UNC X 3/4 FLANGE HEX BOLT
6	32	470121	1/4UNC HEX FLANGE LOCK NUT
7	4	470122	1/4UNC X 1/2 FLANGE HEX BOLT
8	2	470151	UPPER REAR PANEL SCREEN CLIP
9	6	472352	#10-24THD IN X 9/16 TEK TYP 3
10	1	472251	MTG SOCKET
11	1	472249	SLOW MOVING VEHICLE SIGN
12	1	472250	SPADE MTG BRKT
13	4	656998	RUBBER HOOK
14	4	656999	RUBBER HOOK ANCHOR BRKT
15	1	659929	LWR BACK PANEL SCRNL, 284 98
16	1	660205	LWR REAR PANEL WLD 204SP 2001
17	1	659803	LWR FRT SHIELD 280 89
18	1	659804	LWR SCREEN WLD 280 89
19	1	659906	RH FRT SIDE SCRNL WLD, 284 94
20	1	659907	LH FRT SIDE SCRNL WLD, 284 94
21	1	659852	SMV SIGN MTG BRKT 8200 89
22	4	900002	1/4UNC X 3/4 HEX BOLT
23	10	900005	1/4UNC X 1 1/2 HEX BOLT
24	18	914000	1/4UNC HEX STOVER NUT
25	5	193016	QUICKEDGE TRIM .060 TO .170
26	4	900006	1/4UNC X 1 3/4 HEX BOLT
27	1	659889	RH REAR SIDE SCRNL WLD 2XX 92
28	1	659890	LH REAR SIDE SCRNL WLD 2XX 92
29	1	659895	RH LWR SIDE SHIELD 200/280 92
30	1	659896	LH LWR SIDE SHIELD 200/280 92
31	1	659853	200 LWR FRONT SHIELD 89
32	1	002229	REAR CUTTER TOP EXTEN FLAP
33	1	002230	REAR CUTTER TOP EXTEN FLAP KPR

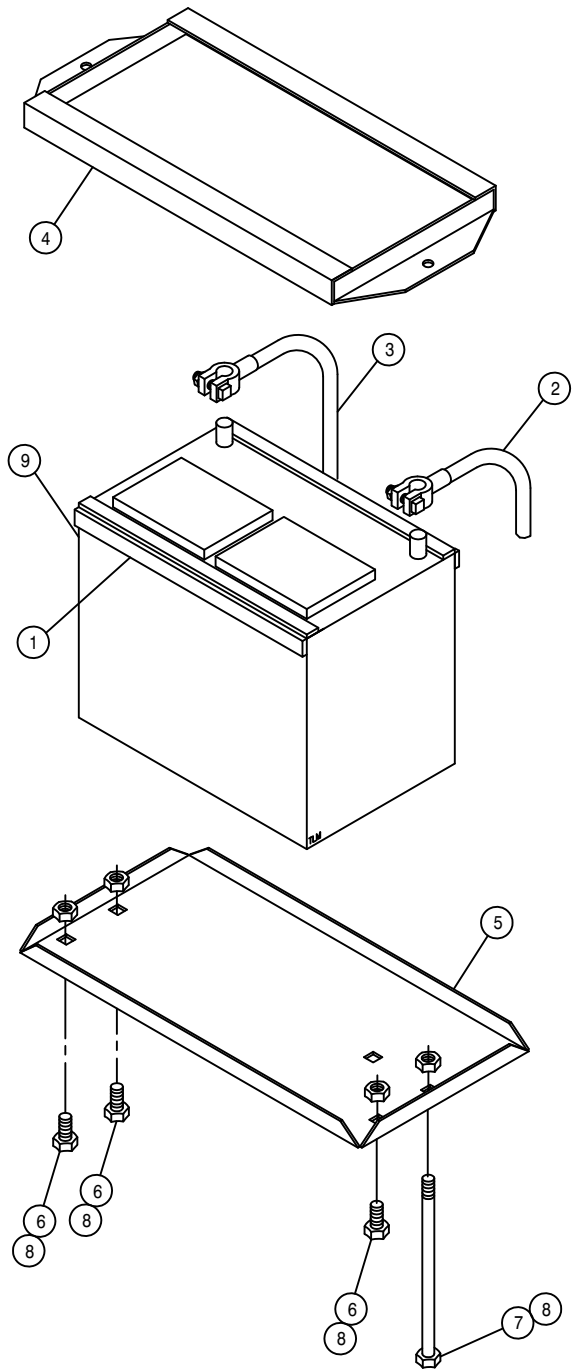

BATTERY BOX ASSEMBLY

DET. QTY PART NO. DESCRIPTION

1	4	193022	STICKERTITE 1/4 X 3/4
2	1	291128	BATTERY CABLE 48 IN
3	1	291530	BATTERY GROUND CABLE, 23"
4	1	341322	BATTERY HOLD DOWN WLD 1981
5	1	361149	BATTERY BOX 8300-8400 1981
6	3	900128	3/8UNC X 3/4 HEX BOLT
7	2	901150	3/8UNC X 9" CARR BOLT
8	5	914004	3/8UNC HEX STOVER NUT
9	1	291122	BATTERY, 12V 950CCA, SAE POST

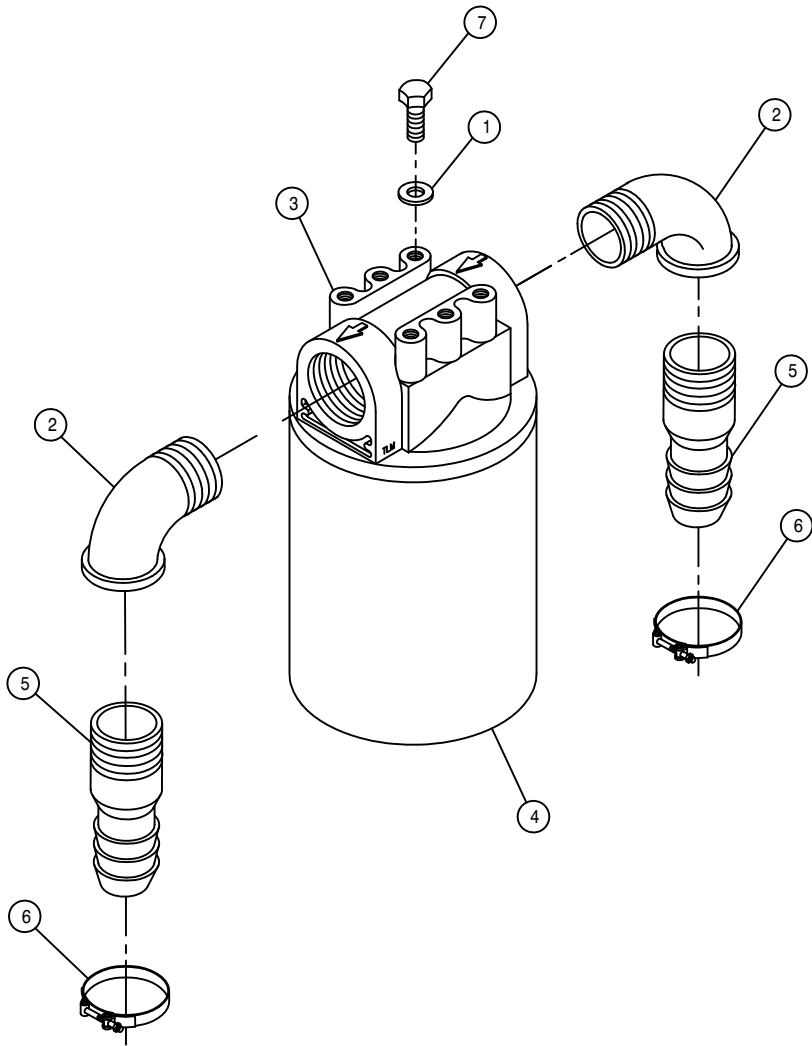

DETASSELER FILTER ASSEMBLY

DET. QTY PART NO. DESCRIPTION

1	4	920501	5/16 LOCK WASHER
2	2	506410	BLK PIPE ST EL 90DEG 1.25NPT
3	1	605601	PARKER FILTER ASSY, 10M, 1.25NPT
4	1	605602	PARKER FILTER ELEMENT, 10MICRON
5	2	715660	HOSE BARB 1 1/4NPT X 1 1/4
6	2	520132	1.62/1.87 T-BOLT HOSE CLAMP SS
7	4	900062	5/16UNC X 1/2 HEX BOLT

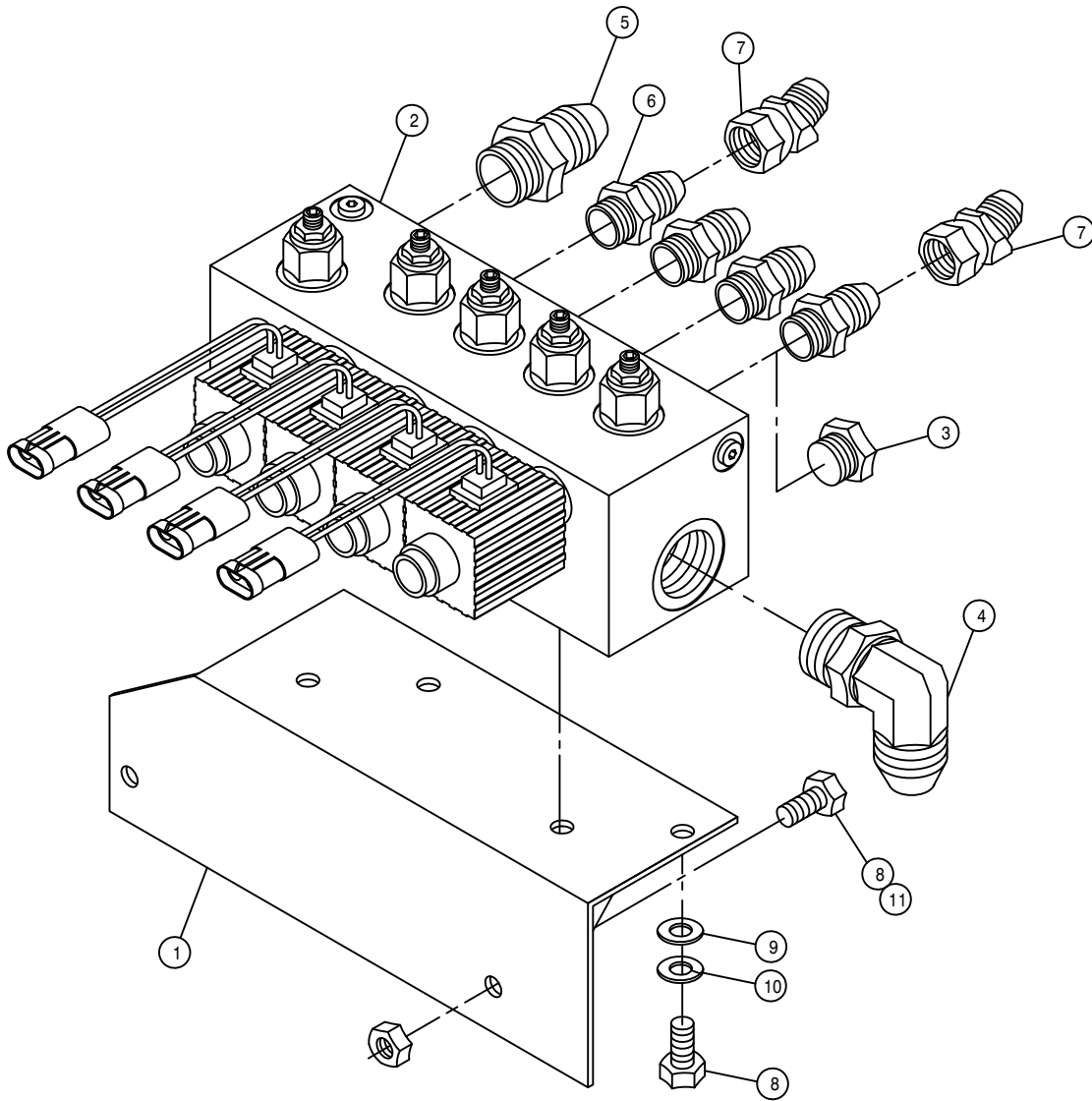

MOTOR CONTROL VALVE ASSEMBLY

DET.	QTY	PART NO.	DESCRIPTION	
				200
1	1	341846	MTR CTRL VLV MT WLD	
2	1	606034	MTR CONTROL ELECT VLV	
3	1	610186	1 1/16MOR PLUG	
4	1	618178	1 5/16MJIC-90-1 5/16MOR LBO	
5	1	618186	1 5/16MJIC-1 5/16MOR ADPTR	
6	4	618469	3/4MJIC-1 1/16MOR ADPTR	
7	2	618590	3/4MJIC-45-3/4FJIC SWIV LBO	
8	4	900128	3/8UNC X 3/4 HEX BOLT	
9	2	920002	3/8 SAE FLAT WASHER	
10	2	920502	3/8 LOCK WASHER	
11	2	914004	3/8UNC HEX STOVER NUT	

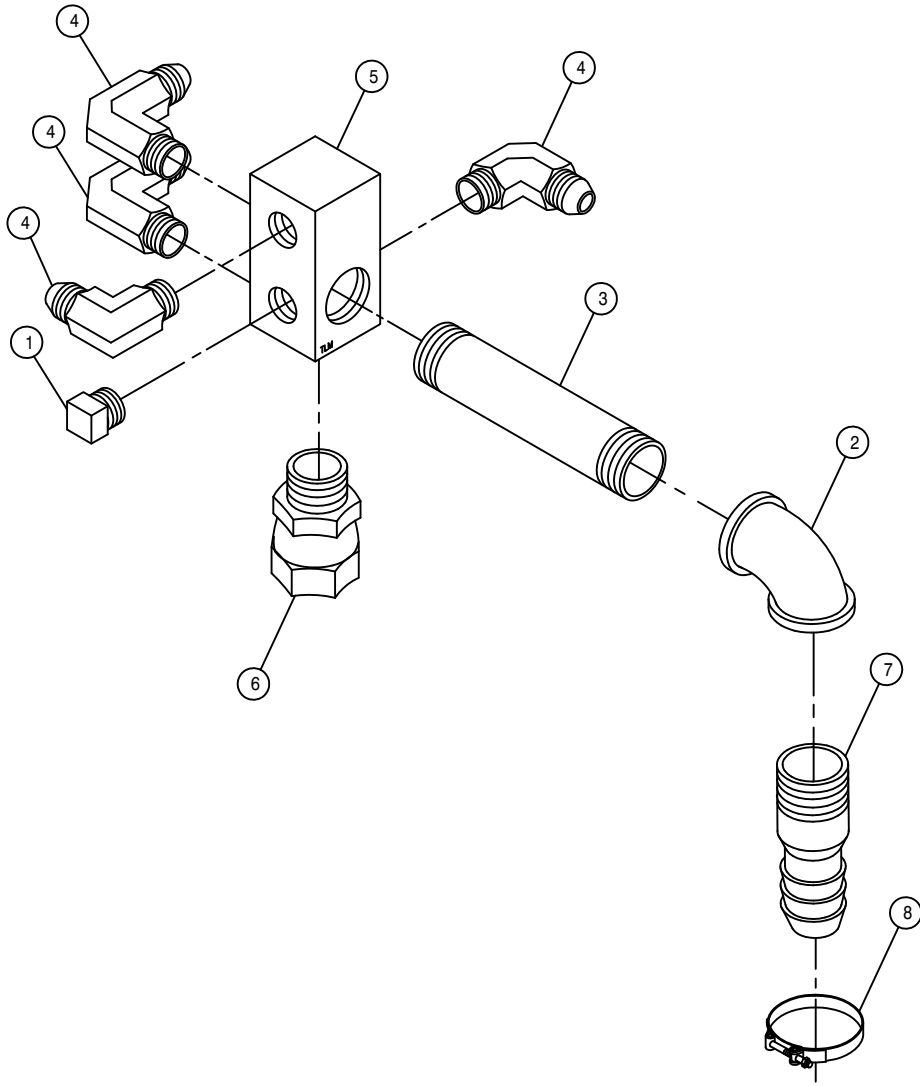

RETURN MANIFOLD FILTER ASSEMBLY

DET. QTY PART NO. DESCRIPTION

1	1	503700	PIPE PLUG .50NPT SQ HD
2	1	505300	BLK PIPE EL 90DEG 1.00NPT
3	1	505209	BLK PIPE NIPPLE 1.00NPT-6.00
4	4	611145	3/4MJIC-90-1/2MNPT LBO
5	1	614633	HYD MANIF 8200 86
6	1	618587	1 5/16FJIC SWIV-1MNPT
7	1	714561	1.00NPT-1.25 HOSE BARB
8	1	520132	1.62/1.87 T-BOLT HOSE CLAMP SS

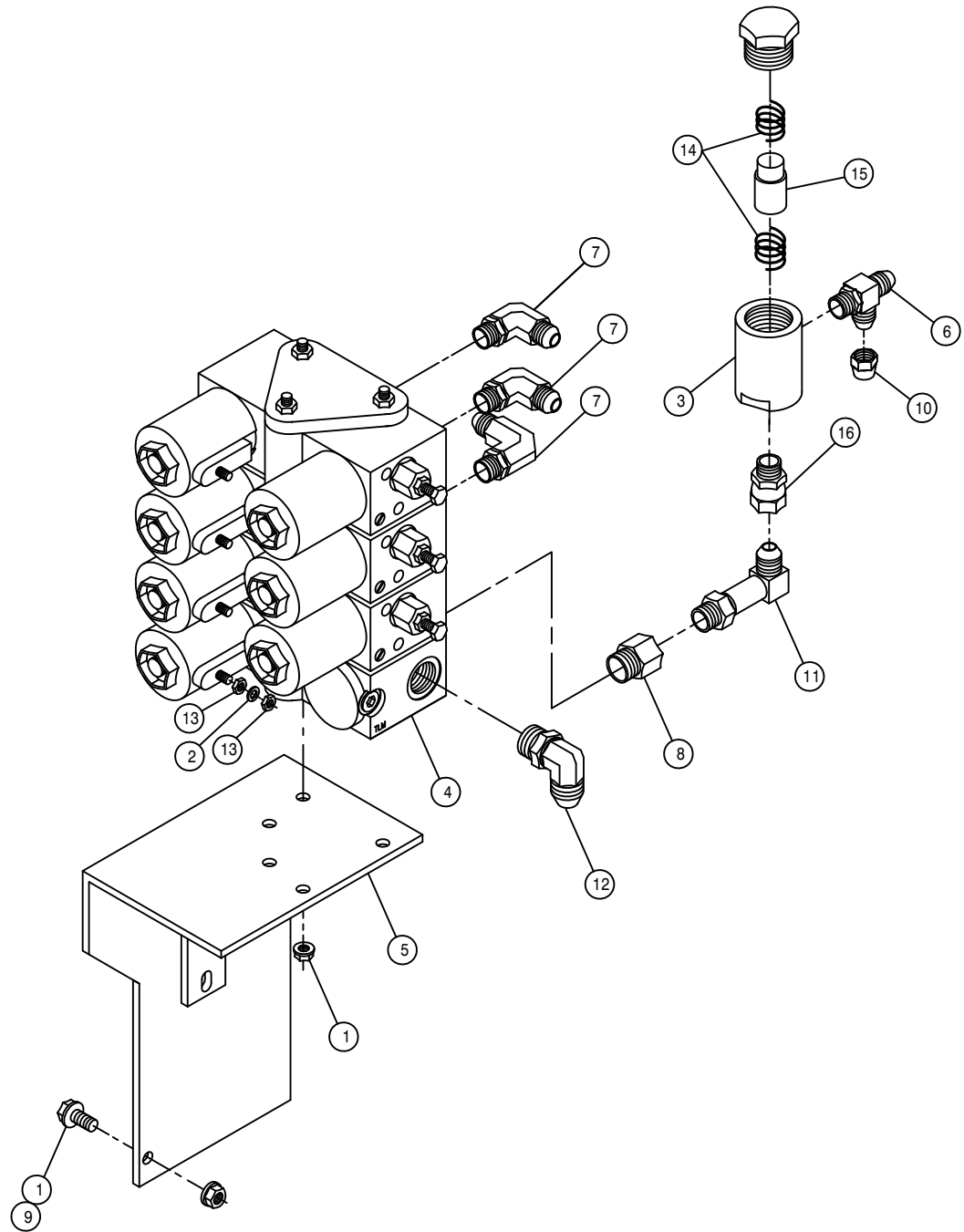

3-LIFT ELECTRIC VALVE ASSEMBLY

DET. QTY PART NO. DESCRIPTION

1	6	470121	1/4UNC HEX FLANGE LOCK NUT
2	7	473821	#10 INT TOOTH WASHER
3	1	605615	HYD FILTER, INLINE 25M 9/16FOR
4	1	610532	ELECT HYD STACK VLV, 3 SECT
5	1	610602	ELECT VLV MT WLD, LS SYS204/284
6	1	618444	9/16MOR RUN TEE-9/16MJIC
7	3	618119	9/16MJIC-90-9/16MOR LBO
8	1	618170	3/4MOR-9/16FOR ADPTR
9	3	470118	1/4UNC X 3/4 FLANGE HEX BOLT
10	1	618531	9/16FJIC CAP NUT
11	1	618440	9/16MJIC-90-9/16MOR EX LG LBO
12	1	618600	9/16MJIC-90-7/8MOR LBO
13	14	910027	10-32 HEX NUT
14	1	605617	SPRING KIT, HYD FILTER 605615
15	1	605616	ELEMENT, 25M HYD FILTER 605615
16	1	618668	9/16FJIC SWIV-9/16MOR ADPTR

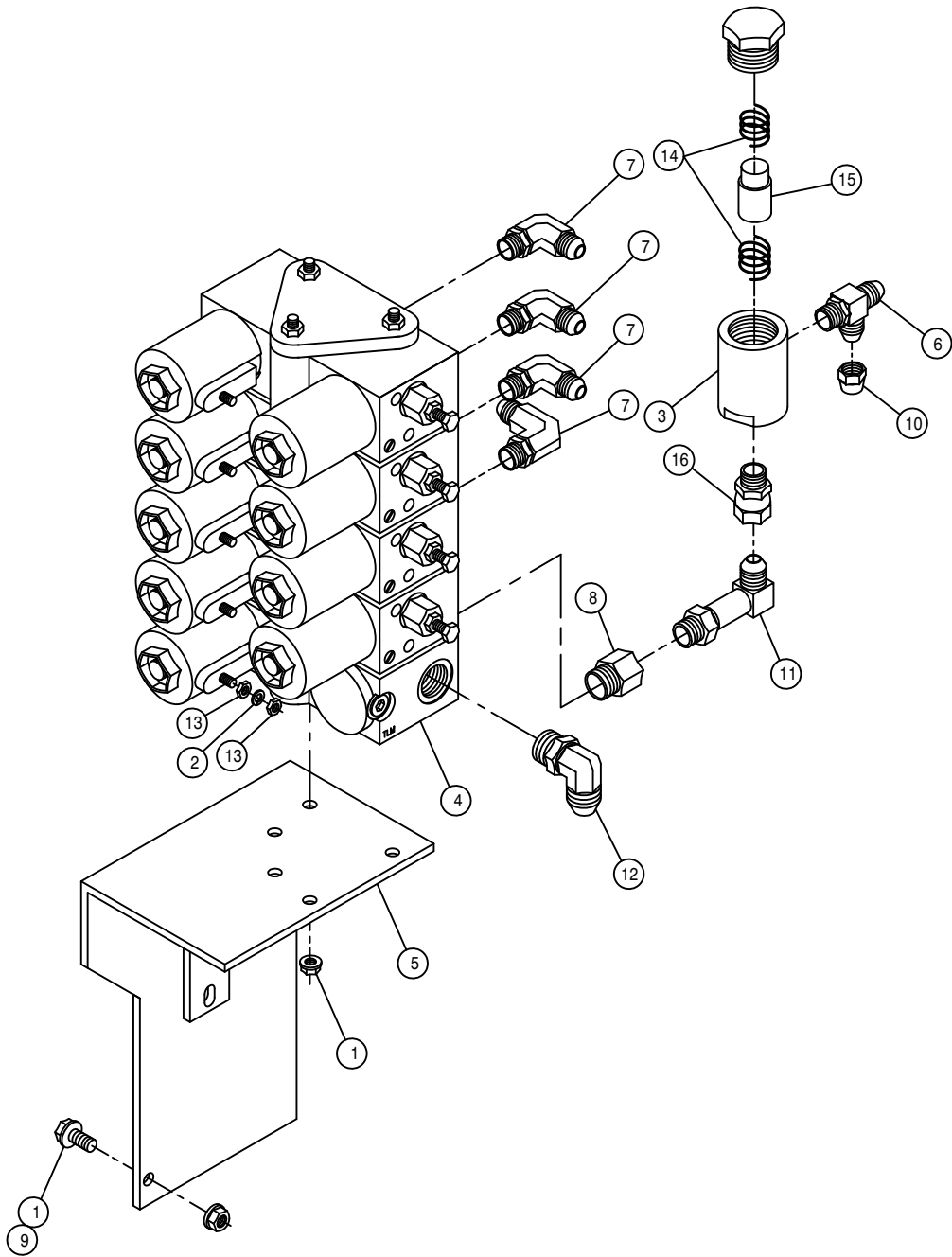

4-LIFT ELECTRIC VALVE ASSEMBLY

DET. QTY PART NO. DESCRIPTION

DET.	QTY	PART NO.	DESCRIPTION
1	6	470121	1/4UNC HEX FLANGE LOCK NUT
2	9	473821	#10 INT TOOTH WASHER
3	1	605615	HYD FILTER, INLINE 25M 9/16FOR
4	1	610613	ELECT HYD STACT VLV, 4 SECT
5	1	610602	ELECT VLV MT WLD, LS SYS204/284
6	1	618444	9/16MOR RUN TEE-9/16MJIC
7	4	618119	9/16MJIC-90-9/16MOR LBO
8	1	618170	3/4MOR-9/16FOR ADPTR
9	3	470118	1/4UNC X 3/4 FLANGE HEX BOLT
10	1	618531	9/16FJIC CAP NUT
11	1	618440	9/16MJIC-90-9/16MOR EX LG LBO
12	1	618600	9/16MJIC-90-7/8MOR LBO
13	18	910027	10-32 HEX NUT
14	1	605617	SPRING KIT, HYD FILTER 605615
15	1	605616	ELEMENT, 25M HYD FILTER 605615
16	1	618668	9/16FJIC SWIV-9/16MOR ADPTR

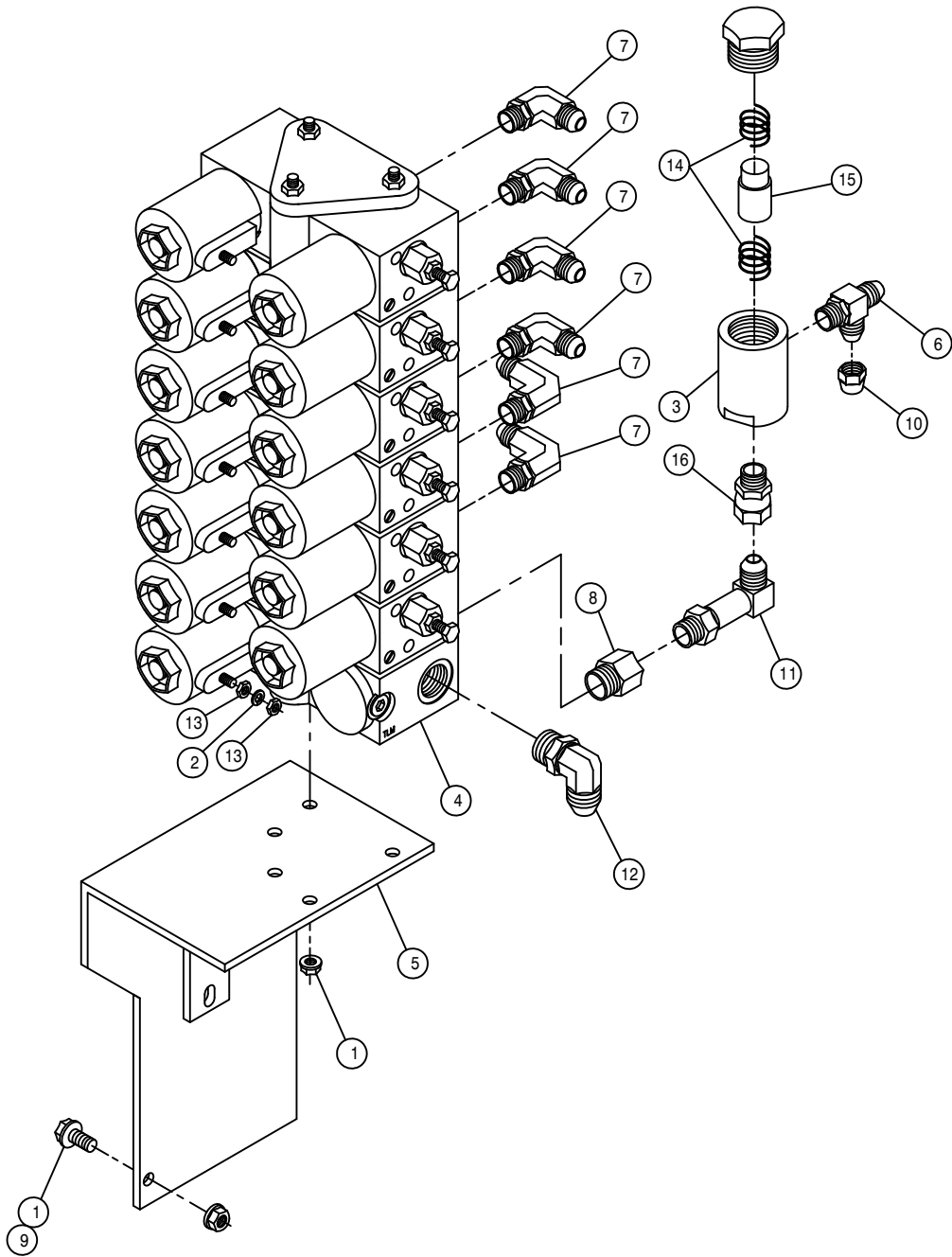

6-LIFT ELECTRIC VALVE ASSEMBLY

DET.	QTY	PART NO.	DESCRIPTION
	1	6 470121	1/4UNC HEX FLANGE LOCK NUT
	2	13 473821	#10 INT TOOTH WASHER
	3	1 605615	HYD FILTER, INLINE 25M 9/16FOR
	4	1 610615	ELECT HYD STACT VLV, 6 SECT
	5	1 610602	ELECT VLV MT WLD, LS SYS204/284
	6	1 618444	9/16MOR RUN TEE-9/16MJIC
	7	6 618119	9/16MJIC-90-9/16MOR LBO
	8	1 618170	3/4MOR-9/16FOR ADPTR
	9	3 470118	1/4UNC X 3/4 FLANGE HEX BOLT
	10	1 618531	9/16FJIC CAP NUT
	11	1 618440	9/16MJIC-90-9/16MOR EX LG LBO
	12	1 618600	9/16MJIC-90-7/8MOR LBO
	13	26 910027	10-32 HEX NUT
	14	1 605617	SPRING KIT, HYD FILTER 605615
	15	1 605616	ELEMENT, 25M HYD FILTER 605615
	16	1 618668	9/16FJIC SWIV-9/16MOR ADPTR

47

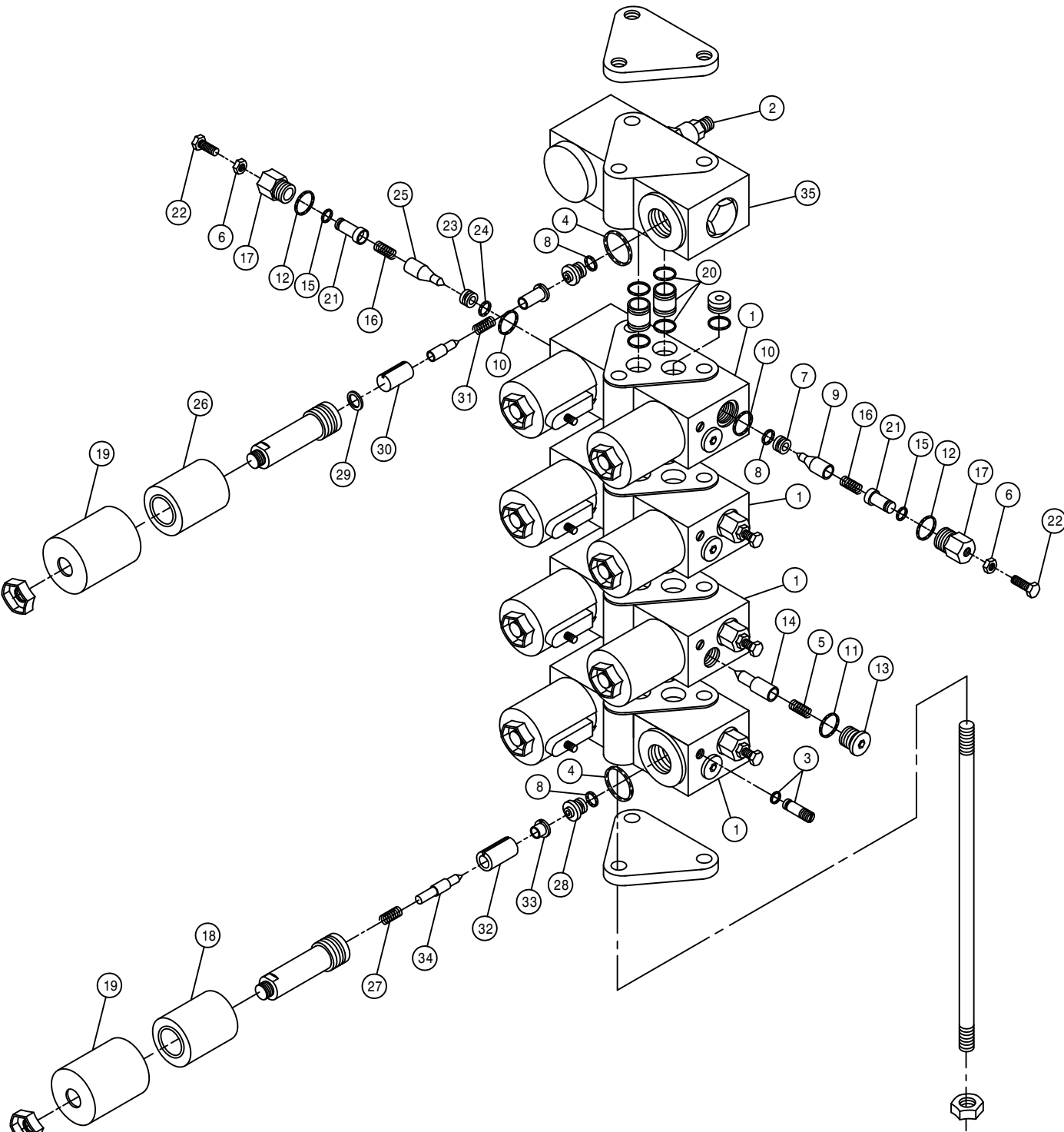

ELECTROHYDRAULIC VALVE

DET.	QTY	PART NO.	DESCRIPTION	
1	4	610533	UNBALANCED LOAD VALVE	89
2	1	610551	R.V. CARTRIDGE FOR 610532	90
3	8	610267	SEAL PLUG ASSY FOR 610257	
4	9	871019	ORING, 13/16 X 15/16 NEO 90D	
5	4	610491	SPRING AM-501-3-035 FOR610485	
6	8	910000	1/4UNC HEX NUT	
7	4	610488	ORIFICE PRESSED IN BLACK	
8	13	871010	ORING 1/4 X 3/8 VITON 90D	
9	4	610129	OBS>:POPPET,ELE VLV,UNBAL LOAD	
10	8	870013	ORING, 7/16 X 9/16 NEO 70D	
11	4	871904	ORING, .351 X .072CS NEO 90D	
12	8	871906	ORING, .468ID X .078CS NEO 90D	
13	4	610130	PLUG, SAE4,ELECT VALVE,UNBAL	
14	4	610489	OBS>:CHECK VLV POPPET	
15	8	871008	O-RING 3/16 X 5/16 90D	
16	8	610492	SPRING AM-570-3-126 FOR610485	
17	8	610453	VLV CAP	
18	8	610493	COIL FOR 610485	86
19	9	610113	COVER, ELECT VALVE, NON ADJ	
20	8	610534	THRU TUBE ASSY ELEC VLV	89
21	8	610452	ADJ VLV STOP	
22	8	900003	1/4UNC X 1" HEX BOLT	
23	4	610494	ORIFICE FOR 610485	
24	4	871056	O-RING	90D
25	4	610495	POPPET FOR 610485AM-570-3-654	
26	1	610076	COIL, ELECT STACK VALVE	
27	8	610127	SPRING,ELECT VALVE,UNBAL LOAD	
28	8	610108	ORIFICE 040, ELECT VALVE	
29	1	610084	WASHER, ELECT-HYD VALVE	
30	1	610112	ARMATURE, ELECT VALVE	
31	1	610110	SPRING, ELECT VALVE, NON ADJ	
32	8	610126	ARMATURE, ELECT VALVE, UNBAL	
33	8	610133	POLE PIECE,ELECT VALVE, UNBAL	
34	8	610490	POPPET FOR 610485AM-501-3-033	
35	1	610679	UNLOAD RELIEF VALVE	

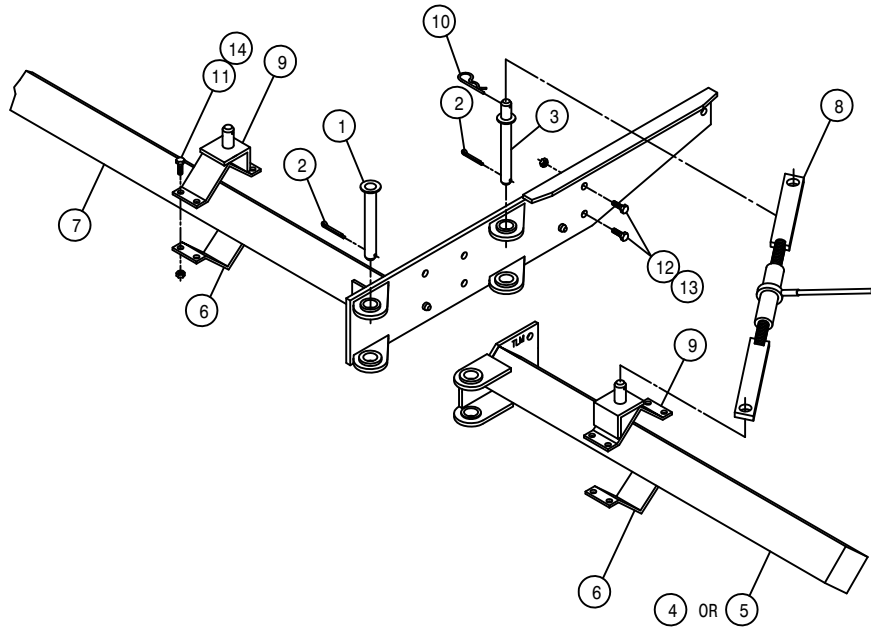

6-ROW OUTRIGGER ASSEMBLY

DET. QTY PART NO. DESCRIPTION

1	2	438283	OUTRGR PIVOT PIN WLD 8200	86
2	4	470117	COTTER PIN 3/16 1 3/4 SQ CUT	
3	2	438474	STABILIZER MT PIN WLD 10-12R	
4	1	438277	RH 32IN OUTRGR WLD8200-850086	
5	1	438282	LH 32IN OUTRGR WLD8200-850086	
6	4	438324	75IN OUTRGR BRACE CLAMP	
7	1	438530	204 TOOL BAR WLD,12R 5/6L	96
8	2	438657	RATCHET JACK WLD	
9	4	438397	STABILIZER PIN MT WLD	90
10	4	611016	HAIR PIN #6	
11	16	900265	1/2UNC X 1 1/2 HEX BOLT	
12	8	900334	5/8UNC X 1 3/4 HEX BOLT	
13	8	914010	5/8UNC HEX STOVER NUT	
14	16	914008	1/2UNC HEX STOVER NUT	

QUANTITY LISTED IS FOR ONE MACHINE.

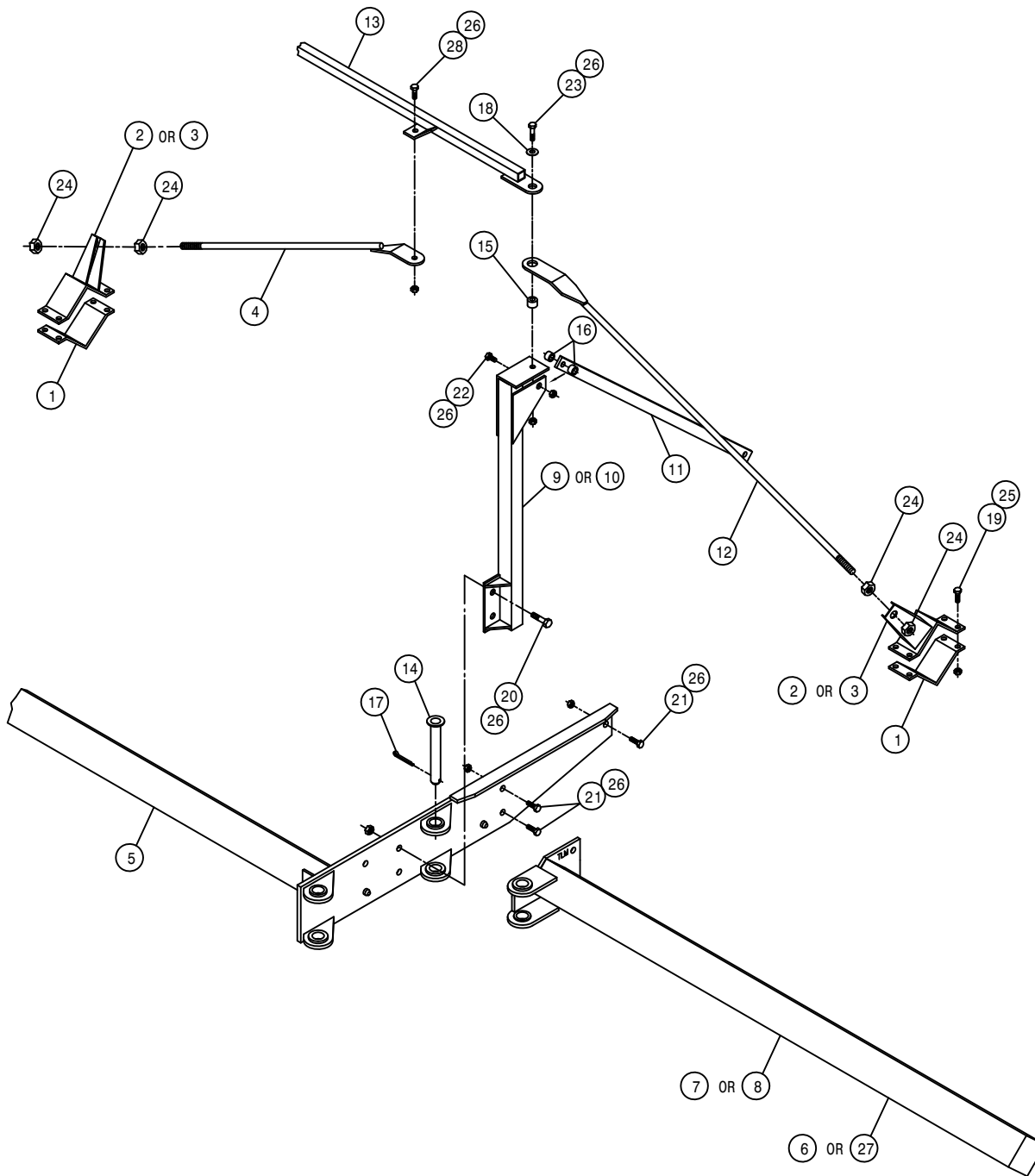

8-ROW, 3-4 LIFT OUTRIGGER ASSEMBLY

DET. QTY PART NO. DESCRIPTION

1	4	438324	75IN OUTRGR BRACE CLAMP	
2	2	438362	RH OUTRGR CLAMP WLD 200	89
3	2	438363	LH OUTRGR CLAMP WLD 200	89
4	2	438469	OUTRGR TIE BAR WLD 200 10-12R	
5	1	438530	204 TOOL BAR WLD, 12R 5/6L	96
6	1	438497	RH 82" OUTRGR WLD, 204	94
7	1	438307	RH 75IN OUTRGR WLD8200-850086	
8	1	438309	LH 75IN OUTRGR WLD8200-850086	
9	1	438536	RH OUTRGR SUPP POST WLD10/12R	
10	1	438537	LH OUTRGR SUPP POST WLD10/12R	
11	2	438543	OUTRGR SUPP BRACE, 10/12R	96
12	2	438676	OUTRGR SUPP ROD WLD 72" 8R	01
13	1	438672	204 TIE TUBE WLD	2001
14	2	438283	OUTRGR PIVOT PIN WLD 8200	86
15	2	438232	BUSH, 1.00 OD X .656ID X .28	
16	4	438542	BUSH, 1.00 OD X .656ID X .78	
17	2	470117	COTTER PIN 3/16 1 3/4 SQ CUT	
18	2	483037	5/8 REGULAR FLAT WASHER	
19	16	900265	1/2UNC X 1 1/2 HEX BOLT	
20	4	900336	5/8UNC X 2 1/2 HEX BOLT	
21	6	900334	5/8UNC X 1 3/4 HEX BOLT	
22	2	900339	5/8UNC X 3 1/4 HEX BOLT	
23	2	900352	5/8UNC X 2 1/4 HEX BOLT	
24	8	910012	3/4UNC HEX NUT	
25	16	914008	1/2UNC HEX STOVER NUT	
26	16	914010	5/8UNC HEX STOVER NUT	
27	1	438498	LH 82" OUTRGR WLD, 204	94
28	2	900333	5/8UNC X 1 1/2 HEX BOLT	

QUANTITY LISTED IS FOR ONE MACHINE.

8-ROW, 3-4 LIFT OUTRIGGER ASSEMBLY

DET. QTY PART NO. DESCRIPTION

DET.	QTY	PART NO.	DESCRIPTION
1	4	438324	75IN OUTRGR BRACE CLAMP
2	4	438367	HOIST COL MT BRKT WLD 200 90
3	2	438657	RATCHET JACK WLD
4	32	914008	1/2UNC HEX STOVER NUT
5	4	438397	STABILIZER PIN MT WLD 90
6	16	914010	5/8UNC HEX STOVER NUT
7	4	438292	TOOL BAR V-PLT WLD 8200 86
8	8	438293	5/8UNC X 6 1/4 CTR U-BOLT TRI
9	2	438474	STABILIZER MT PIN WLD 10-12R
10	2	438476	OUTRGR TRANSPORT BAR 10-12R
11	2	470117	COTTER PIN 3/16 1 3/4 SQ CUT
12	6	611016	HAIR PIN #6
13	16	900265	1/2UNC X 1 1/2 HEX BOLT
14	16	900275	1/2UNC X 4 1/2 HEX BOLT

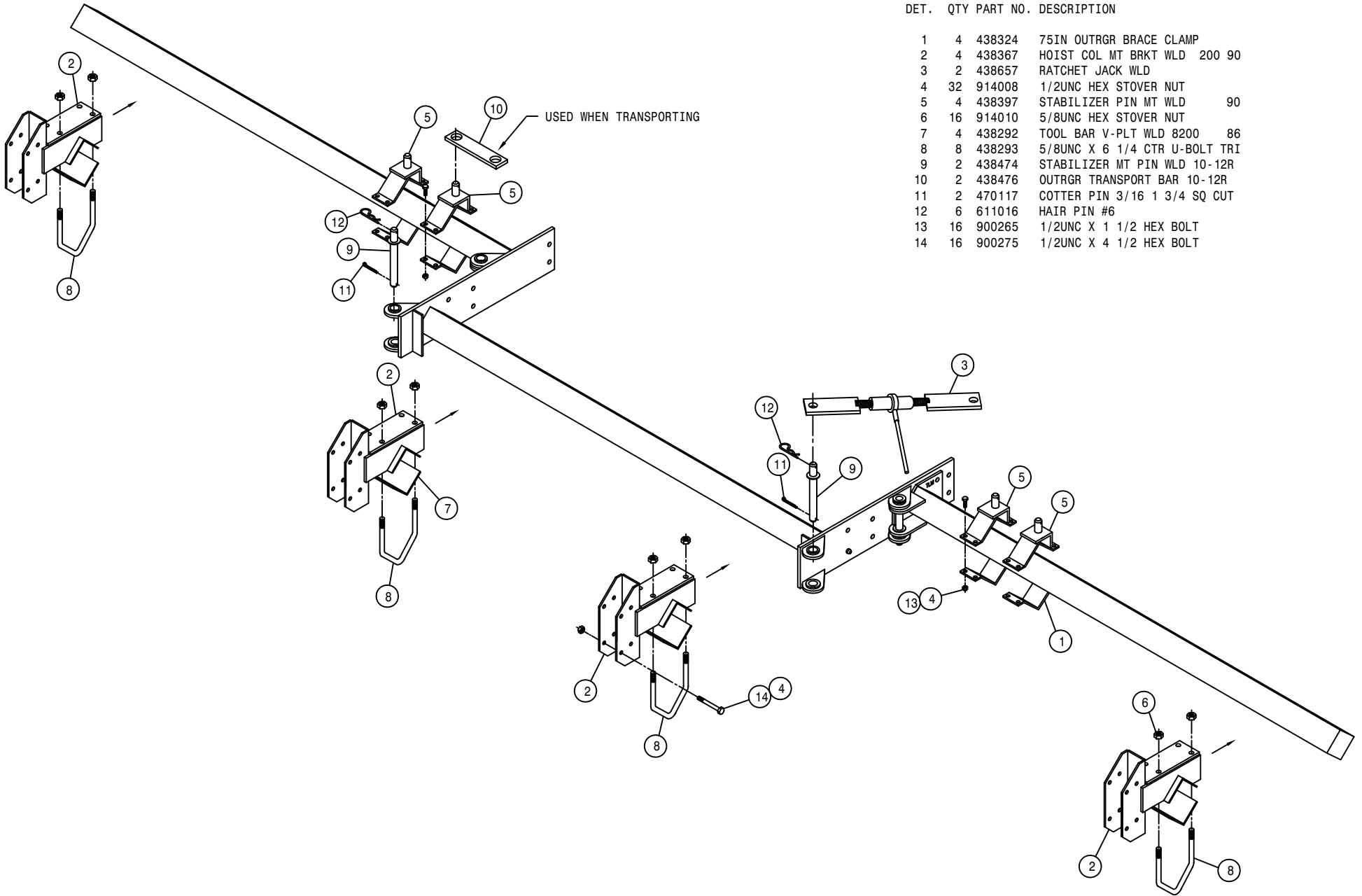

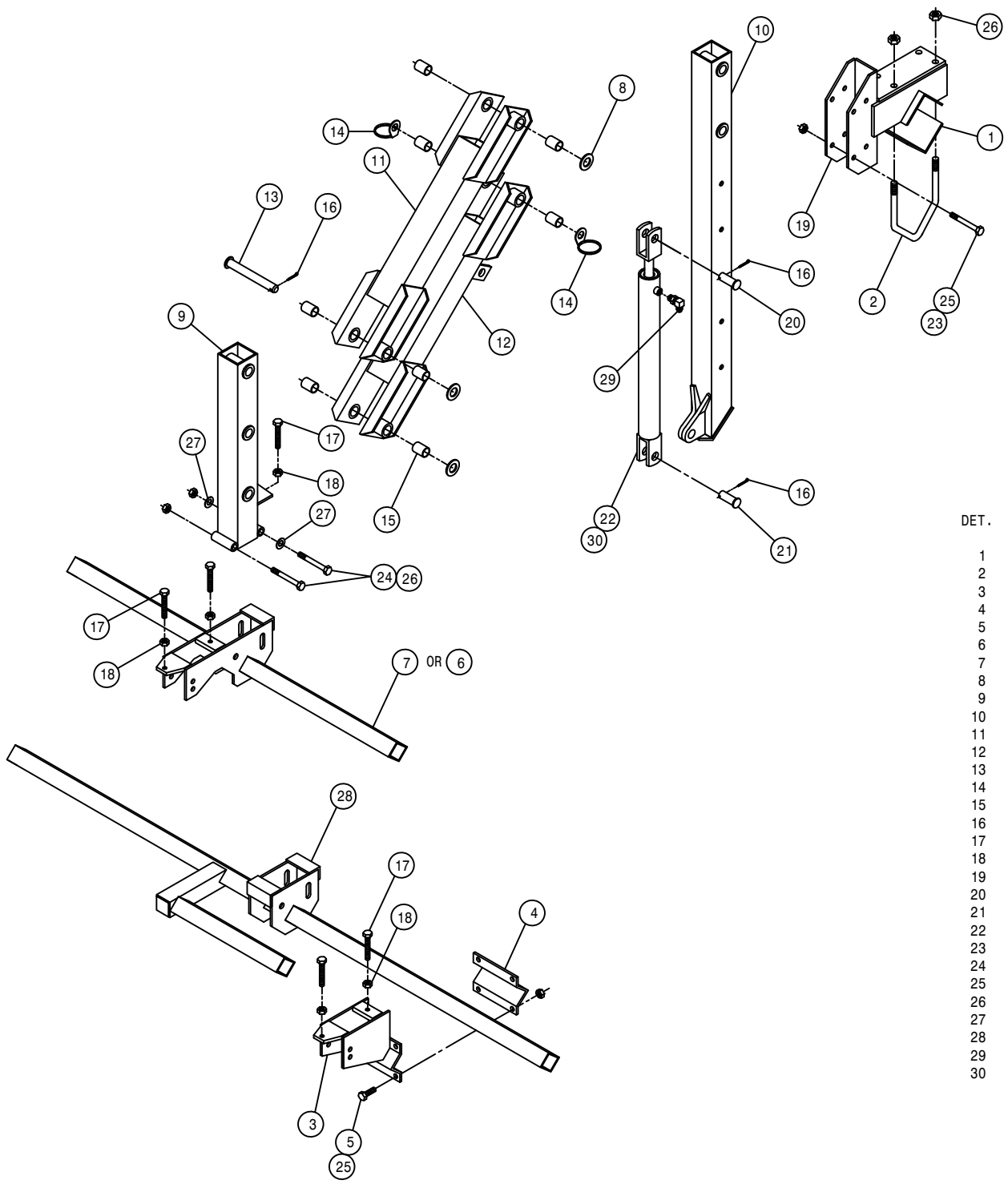

6-8 ROW DETASSLER LIFT ASSEMBLY

DET.	QTY	PART NO.	DESCRIPTION	
1	1	438292	TOOL BAR V-PLT WLD 8200	86
2	2	438293	5/8UNC X 6 1/4 CTR U-BOLT TRI	
3	1	438199	T-TROL MT WLD 8R DETAS	83
4	1	410016	RLR HANGER V 473	
5	4	900265	1/2UNC X 1 1/2 HEX BOLT	
6	1	438500	TOOL BAR WLD, 54"	94
7	1	438194	TOOL BAR WLD DETAS 4-6R 83	
8	3	920008	1" SAE FLAT WASHER	
9	1	438245	TOOL BAR MT WLD,2-POS DETAS	
10	1	438184	HOIST COL WLD DETAS LIFT 83	
11	1	438294	UPPER LIFT ARM WLD 8200	86
12	1	438297	LWR LIFT ARM WLD 8200	86
13	4	438300	LIFT ARM PIVOT PIN WLD8200	86
14	2	438302	HOSE SUPPORT RING WLD	
15	8	121025	JOURNAL BRG, 1.00 ID X 1.50 LG	
16	6	470162	COTTER PIN 3/16 X 1 1/2 SQCUT	
17	5	900538	1/2UNC X 3 1/2 HEX BOLT FULL	
18	5	910008	1/2UNC HEX NUT	
19	1	438367	HOIST COL MT BRKT WLD 200 90	
20	1	472012	CLEVIS PIN, 1.00 X 3.25 PLT	
21	1	472206	PICKER PIN 1 DIA X 2 1/4	
22	1	621506	LIFT CYL ASSY 1W,DETASSELER	
23	4	900275	1/2UNC X 4 1/2 HEX BOLT	
24	2	900343	5/8UNC X 4 1/2 HEX BOLT	
25	8	914008	1/2UNC HEX STOVER NUT	
26	6	914010	5/8UNC HEX STOVER NUT	
27	2	920005	5/8 SAE FLAT WASHER	
28	1	438201	TOOL BAR WLD 8R DETAS 83	
29	1	618119	9/16MJIC-90-9/16MOR LBO	
30	1	621507	REPAIR KIT, HYD CYL 621506	

10-12 ROW, 4-LIFT OUTRIGGER ASSEMBLY

DET. QTY PART NO. DESCRIPTION

DET.	QTY	PART NO.	DESCRIPTION
1	4	438324	75IN OUTGR BRACE CLAMP
2	2	438362	RH OUTGR CLAMP WLD 200 89
3	2	438363	LH OUTGR CLAMP WLD 200 89
4	2	438469	OUTGR TIE BAR WLD 200 10-12R
5	2	438471	OUTGR SUPP ROD WLD 10-12R
6	1	438530	204 TOOL BAR WLD,12R 5/6L 96
7	1	438458	RH 101IN OUTGR WLD 10-12R 92
8	1	438459	LH 101IN OUTGR WLD 10-12R 92
9	1	438536	RH OUTGR SUPP POST WLD10/12R
10	1	438537	LH OUTGR SUPP POST WLD10/12R
11	2	438543	OUTGR SUPP BRACE,10/12R 96
12	2	900333	5/8UNC X 1 1/2 HEX BOLT
13	1	438672	204 TIE TUBE WLD 2001
14	2	438283	OUTGR PIVOT PIN WLD 8200 86
15	2	438232	BUSH, 1.00 OD X .656ID X .28
16	4	438542	BUSH, 1.00 OD X .656ID X .78
17	2	470117	COTTER PIN 3/16 1 3/4 SQ CUT
18	2	483037	5/8 REGULAR FLAT WASHER
19	16	900265	1/2UNC X 1 1/2 HEX BOLT
20	4	900336	5/8UNC X 2 1/2 HEX BOLT
21	6	900334	5/8UNC X 1 3/4 HEX BOLT
22	2	900339	5/8UNC X 3 1/4 HEX BOLT
23	2	900352	5/8UNC X 2 1/4 HEX BOLT
24	8	910012	3/4UNC HEX NUT
25	16	914008	1/2UNC HEX STOVER NUT
26	16	914010	5/8UNC HEX STOVER NUT

QUANTITY LISTED IS FOR ONE MACHINE.

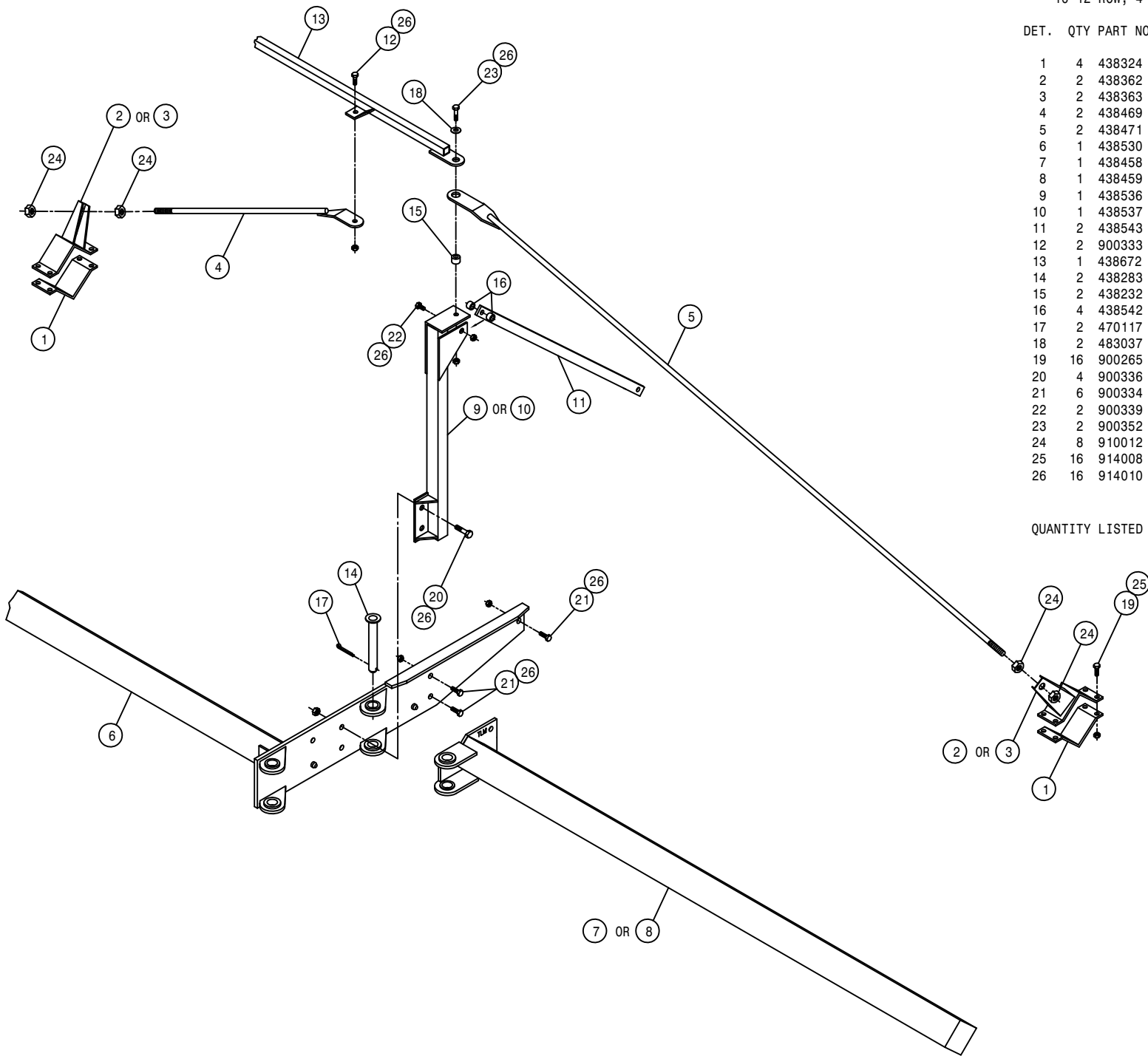

10-ROW, 4-LIFT OUTRIGGER ASSEMBLY

DET. QTY PART NO. DESCRIPTION

DET.	QTY	PART NO.	DESCRIPTION
1	4	438324	75IN OUTGR BRACE CLAMP
2	4	438367	HOIST COL MT BRKT WLD 200 90
3	2	438657	RATCHET JACK WLD
4	32	914008	1/2UNC HEX STOVER NUT
5	4	438397	STABILIZER PIN MT WLD 90
6	16	914010	5/8UNC HEX STOVER NUT
7	4	438292	TOOL BAR V-PLT WLD 8200 86
8	8	438293	5/8UNC X 6 1/4 CTR U-BOLT TRI
9	2	438474	STABILIZER MT PIN WLD 10-12R
10	2	438476	OUTGR TRANSPORT BAR 10-12R
11	2	470117	COTTER PIN 3/16 1 3/4 SQ CUT
12	6	611016	HAIR PIN #6
13	16	900265	1/2UNC X 1 1/2 HEX BOLT
14	16	900275	1/2UNC X 4 1/2 HEX BOLT

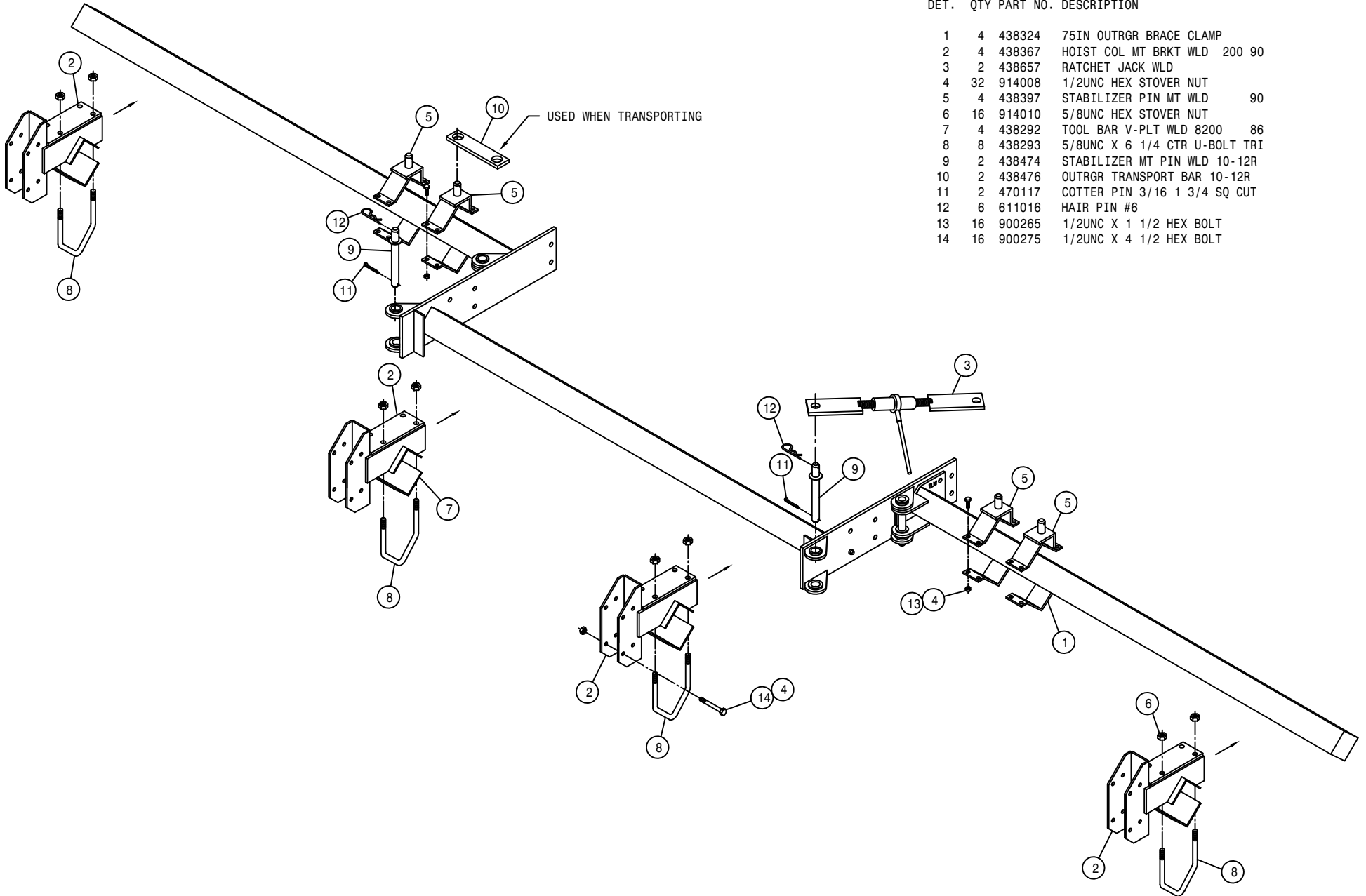

12-ROW, 4-LIFT OUTRIGGER ASSEMBLY

DET. QTY PART NO. DESCRIPTION

DET.	QTY	PART NO.	DESCRIPTION
1	4	438324	75IN OUTRGR BRACE CLAMP
2	2	438367	HOIST COL MT BRKT WLD 200 90
3	2	438657	RATCHET JACK WLD
4	2	390984	COTTER PIN 1/8 X 1 1/4
5	2	438481	HINGED HOIST COL MT WLD, FRT
6	2	438482	HINGED HOIST COL MT WLD, REAR
7	4	438397	STABILIZER PIN MT WLD 90
8	32	914008	1/2UNC HEX STOVER NUT
9	4	438292	TOOL BAR V-PLT WLD 8200 86
10	8	438293	5/8UNC X 6 1/4 CTR U-BOLT TRI
11	2	438474	STABILIZER MT PIN WLD 10-12R
12	2	438476	OUTRGR TRANSPORT BAR 10-12R
13	2	438489	HINGED HOIST COL PIV PIN WLD
14	2	438491	HINGED HOIST COL KPR PIN
15	1	438492	SHORT HINGED COL MT LATCH
16	1	438493	LONG HINGED COL MT LATCH
17	2	470117	COTTER PIN 3/16 1 3/4 SQ CUT
18	2	470120	HAIR PIN 3/32 DIA WIRE
19	6	611016	HAIR PIN #6
20	16	914010	5/8UNC HEX STOVER NUT
21	16	900265	1/2UNC X 1 1/2 HEX BOLT
22	16	900275	1/2UNC X 4 1/2 HEX BOLT
23	2	900337	5/8UNC X 2 3/4 HEX BOLT
24	2	900346	5/8UNC X 6" HEX BOLT
25	4	910010	5/8UNC HEX NUT
26	2	920005	5/8 SAE FLAT WASHER

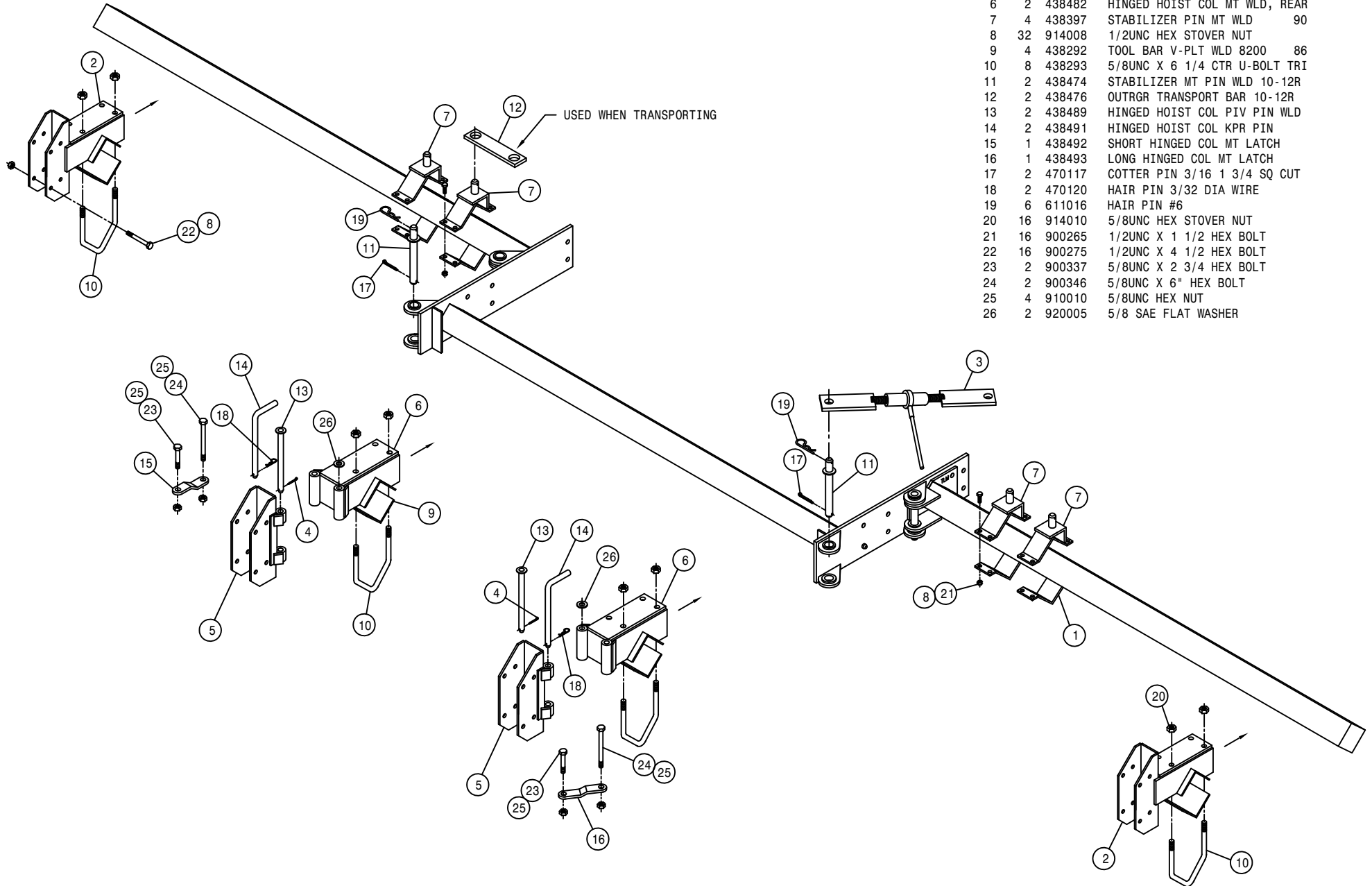

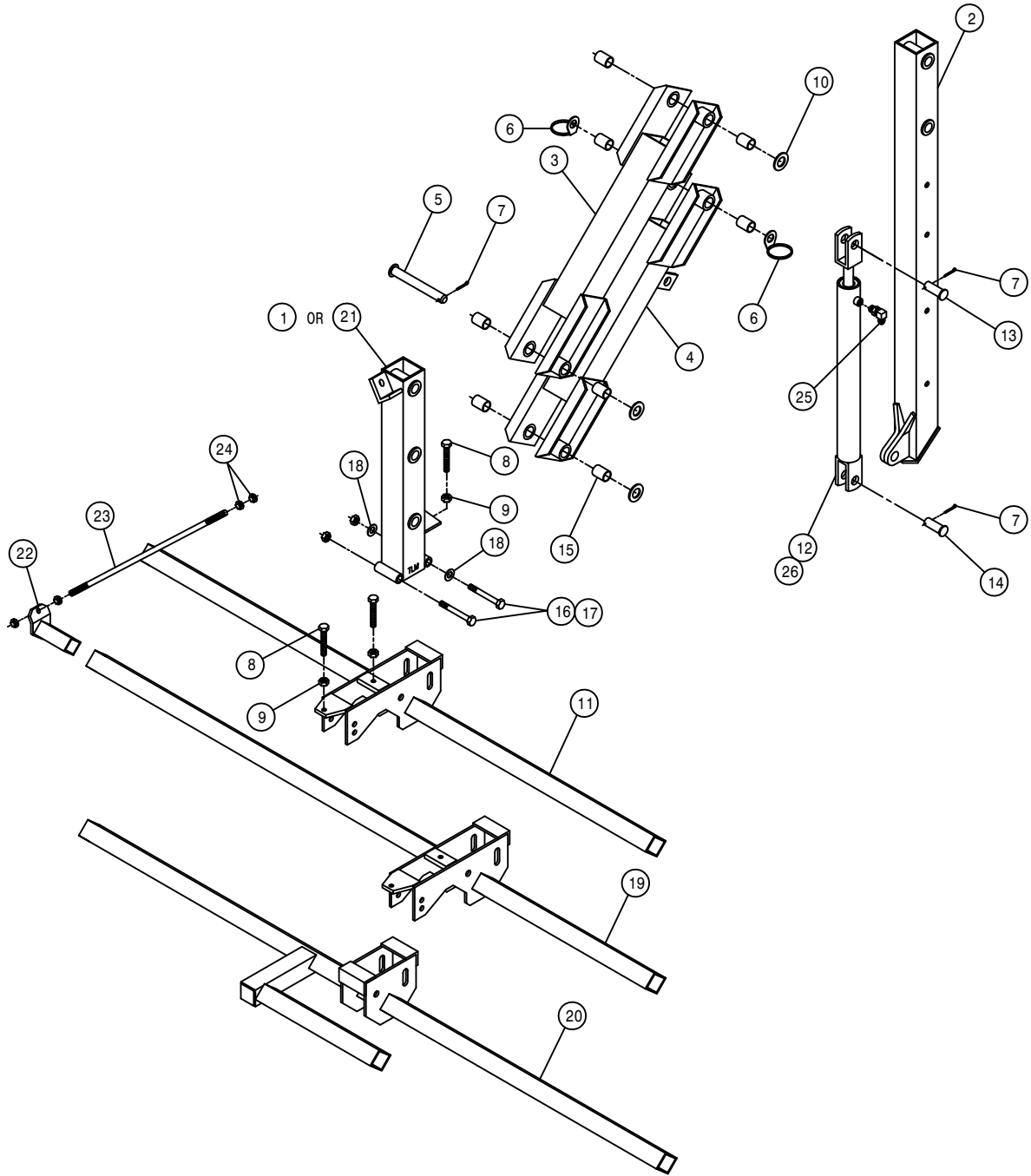

10-12 ROW, 4-LIFT ASSEMBLY

DET.	QTY	PART NO.	DESCRIPTION
1	1	438245	TOOL BAR MT WLD,2-POS DETAS
2	1	438184	HOIST COL WLD DETAS LIFT 83
3	1	438294	UPPER LIFT ARM WLD 8200 86
4	1	438297	LWR LIFT ARM WLD 8200 86
5	4	438300	LIFT ARM PIVOT PIN WLD8200 86
6	2	438302	HOSE SUPPORT RING WLD
7	6	470162	COTTER PIN 3/16 X 1 1/2 SQCUT
8	3	900538	1/2UNC X 3 1/2 HEX BOLT FULL
9	3	910008	1/2UNC HEX NUT
10	3	920008	1" SAE FLAT WASHER
11	1	438194	TOOL BAR WLD DETAS 4-6R 83
12	1	621506	LIFT CYL ASSY 1W,DETASSELER
13	1	472012	CLEVIS PIN, 1.00 X 3.25 PLT
14	1	472206	PICKER PIN 1 DIA X 2 1/4
15	8	121025	JOURNAL BRG, 1.00 ID X 1.50 LG
16	2	900343	5/8UNC X 4 1/2 HEX BOLT
17	2	914010	5/8UNC HEX STOVER NUT
18	2	920005	5/8 SAE FLAT WASHER
19	1	438750	TOOL BAR WLD 10-12R 3-HD DET
20	1	438201	TOOL BAR WLD 8R DETAS 83
21	1	438749	TOOL BAR MT WLD,2-POS W/SUPP
22	1	438226	TOOL BAR SUPP WLD
23	1	438231	TOOL BAR SUPP ROD
24	4	910008	1/2UNC HEX NUT
25	1	618119	9/16MJIC-90-9/16MOR LBO
26	1	621507	REPAIR KIT, HYD CYL 621506

12-ROW, 6-LIFT OUTRIGGER ASSEMBLY

DET. QTY PART NO. DESCRIPTION

DET.	QTY	PART NO.	DESCRIPTION
1	6	438324	75IN OUTRGR BRACE CLAMP
2	3	438362	RH OUTRGR CLAMP WLD 200 89
3	3	438363	LH OUTRGR CLAMP WLD 200 89
4	2	438469	OUTRGR TIE BAR WLD 200 10-12R
5	2	438471	OUTRGR SUPP ROD WLD 10-12R
6	1	438530	204 TOOL BAR WLD,12R 5/6L 96
7	1	438533	RH 133" OUTRGR WLD, 10/12R 96
8	1	438534	LH 133" OUTRGR WLD, 10/12R 96
9	1	438536	RH OUTRGR SUPP POST WLD10/12R
10	1	438537	LH OUTRGR SUPP POST WLD10/12R
11	2	438543	OUTRGR SUPP BRACE,10/12R 96
12	2	438544	OUTRGR SUPP ROD WLD 50"10/12R
13	1	438672	204 TIE TUBE WLD 2001
14	2	438283	OUTRGR PIVOT PIN WLD 8200 86
15	2	438541	BUSH, 1.00 OD X .656ID X .53
16	4	438542	BUSH, 1.00 OD X .656ID X .78
17	2	470117	COTTER PIN 3/16 1 3/4 SQ CUT
18	2	483037	5/8 REGULAR FLAT WASHER
19	24	900265	1/2UNC X 1 1/2 HEX BOLT
20	4	900336	5/8UNC X 2 1/2 HEX BOLT
21	6	900334	5/8UNC X 1 3/4 HEX BOLT
22	2	900339	5/8UNC X 3 1/4 HEX BOLT
23	2	900352	5/8UNC X 2 1/4 HEX BOLT
24	12	910012	3/4UNC HEX NUT
25	24	914008	1/2UNC HEX STOVER NUT
26	16	914010	5/8UNC HEX STOVER NUT
27	2	900333	5/8UNC X 1 1/2 HEX BOLT

QUANTITY LISTED IS FOR ONE MACHINE.

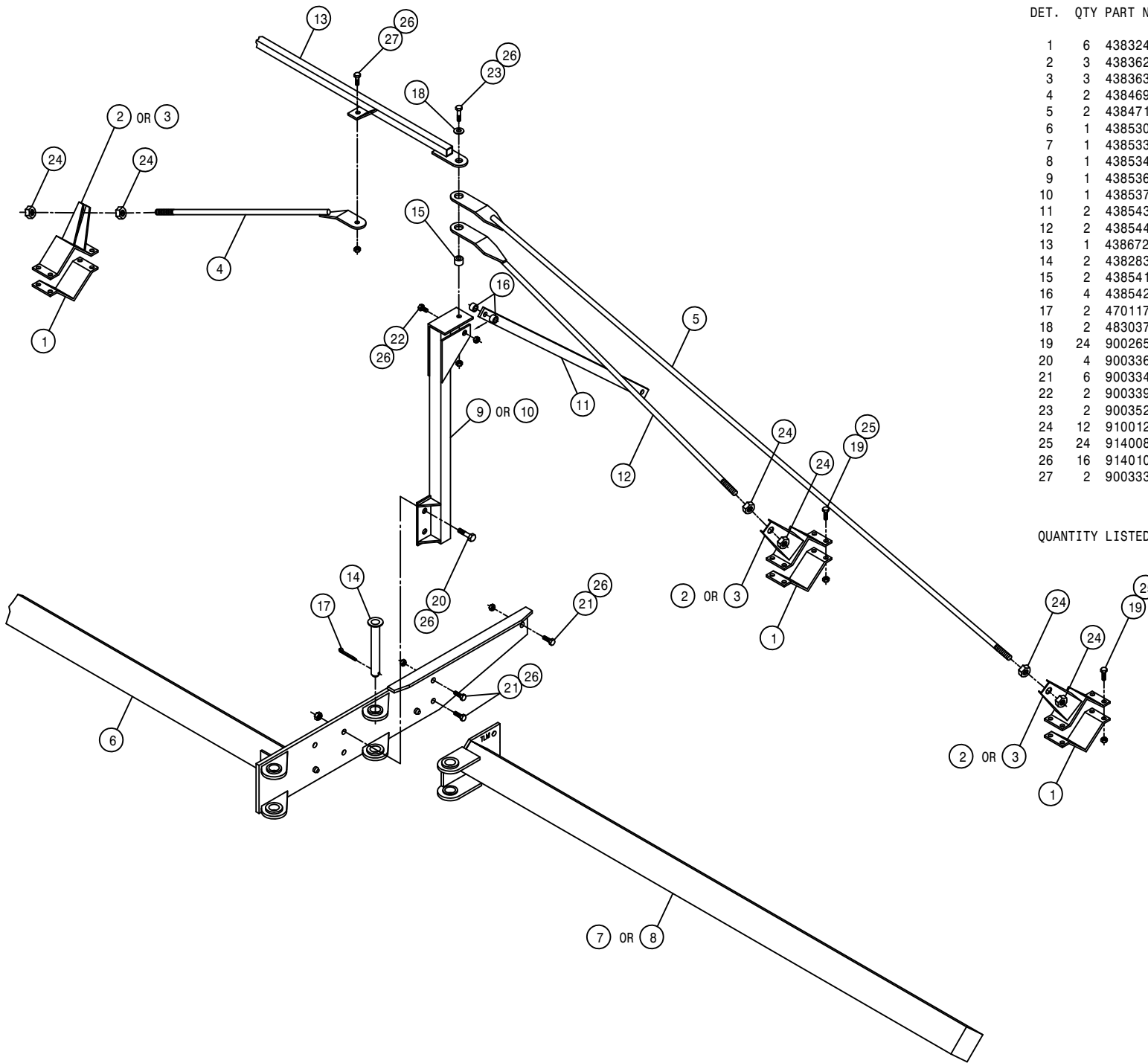

12-ROW, 6-LIFT OUTRIGGER ASSEMBLY

DET. QTY PART NO. DESCRIPTION

DET.	QTY	PART NO.	DESCRIPTION
1	4	438324	75IN OUTRGR BRACE CLAMP
2	6	438367	HOIST COL MT BRKT WLD 200 90
3	2	438657	RATCHET JACK WLD
4	40	914008	1/2UNC HEX STOVER NUT
5	4	438397	STABILIZER PIN MT WLD 90
6	24	914010	5/8UNC HEX STOVER NUT
7	6	438292	TOOL BAR V-PLT WLD 8200 86
8	12	438293	5/8UNC X 6 1/4 CTR U-BOLT TRI
9	2	438474	STABILIZER MT PIN WLD 10-12R
10	2	438476	OUTRGR TRANSPORT BAR 10-12R
11	2	470117	COTTER PIN 3/16 1 3/4 SQ CUT
12	6	611016	HAIR PIN #6
13	16	900265	1/2UNC X 1 1/2 HEX BOLT
14	24	900275	1/2UNC X 4 1/2 HEX BOLT

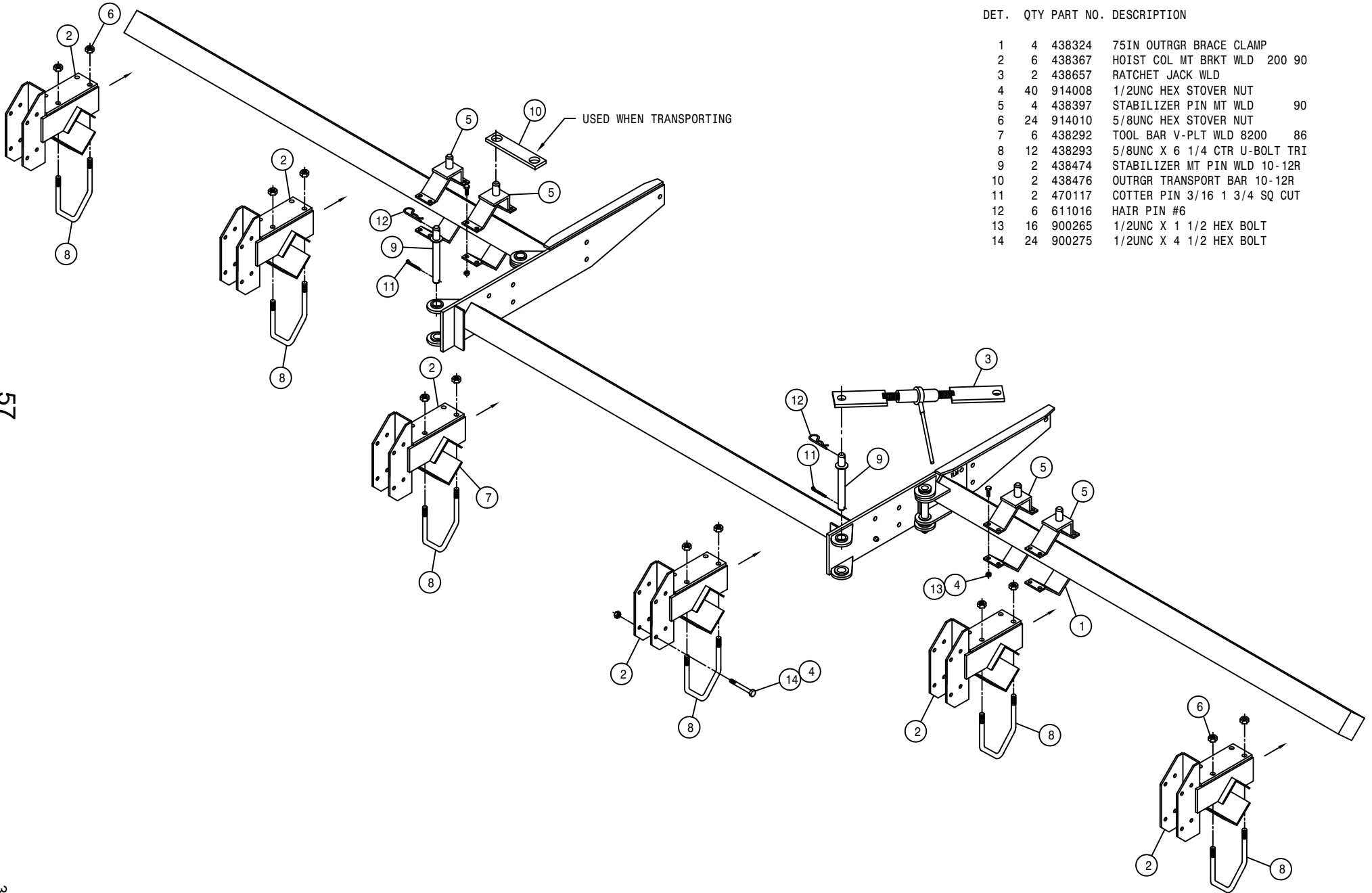

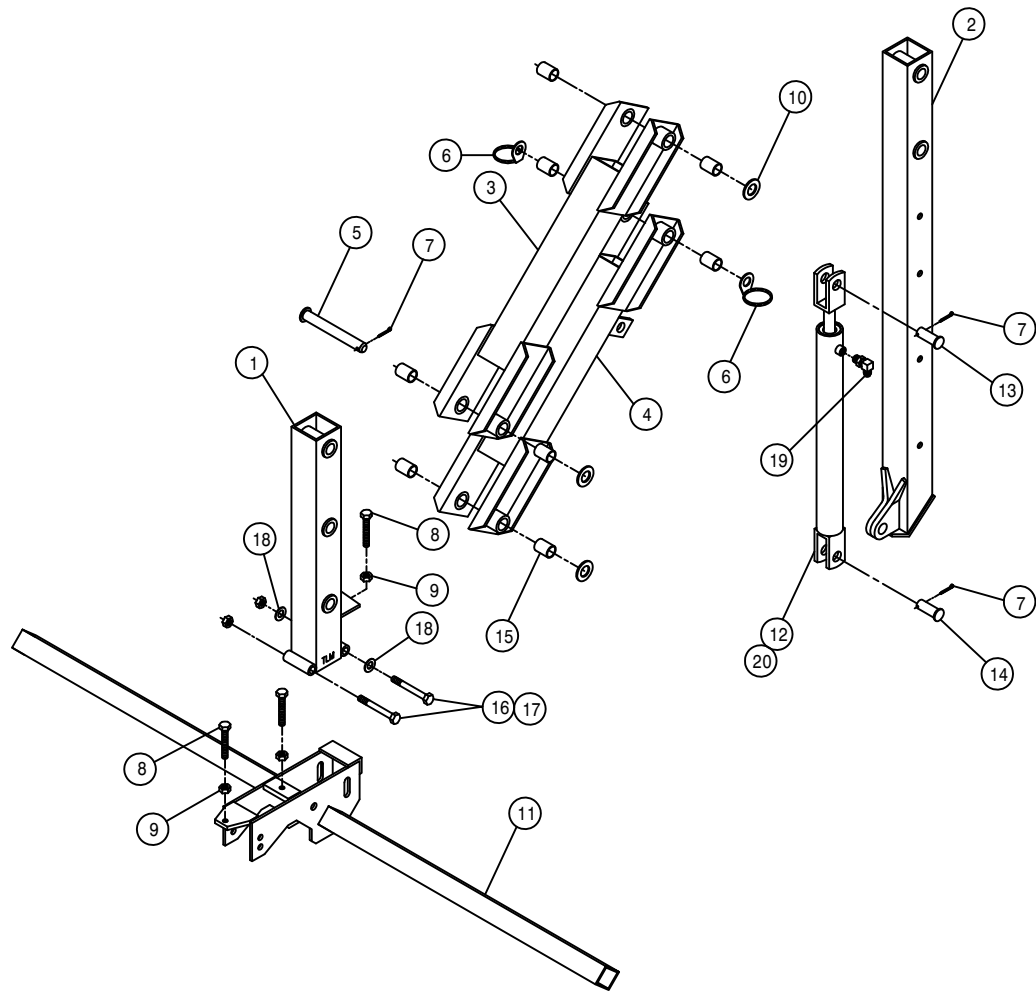

12-ROW, 6-LIFT ASSEMBLY

DET.	QTY	PART NO.	DESCRIPTION
1	1	438245	TOOL BAR MT WLD,2-POS DETAS
2	1	438184	HOIST COL WLD DETAS LIFT 83
3	1	438294	UPPER LIFT ARM WLD 8200 86
4	1	438297	LWR LIFT ARM WLD 8200 86
5	4	438300	LIFT ARM PIVOT PIN WLD8200 86
6	2	438302	HOSE SUPPORT RING WLD
7	6	470162	COTTER PIN 3/16 X 1 1/2 SQ CUT
8	3	900538	1/2UNC X 3 1/2 HEX BOLT FULL
9	3	910008	1/2UNC HEX NUT
10	3	920008	1" SAE FLAT WASHER
11	1	438194	TOOL BAR WLD DETAS 4-6R 83
12	1	621506	LIFT CYL ASSY 1W,DETASSELER
13	1	472012	CLEVIS PIN, 1.00 X 3.25 PLT
14	1	472206	PICKER PIN 1 DIA X 2 1/4
15	8	121025	JOURNAL BRG, 1.00 ID X 1.50 LG
16	2	900343	5/8UNC X 4 1/2 HEX BOLT
17	2	914010	5/8UNC HEX STOVER NUT
18	2	920005	5/8 SAE FLAT WASHER
19	1	618119	9/16MJIC-90-9/16MOR LBO
20	1	621507	REPAIR KIT, HYD CYL 621506

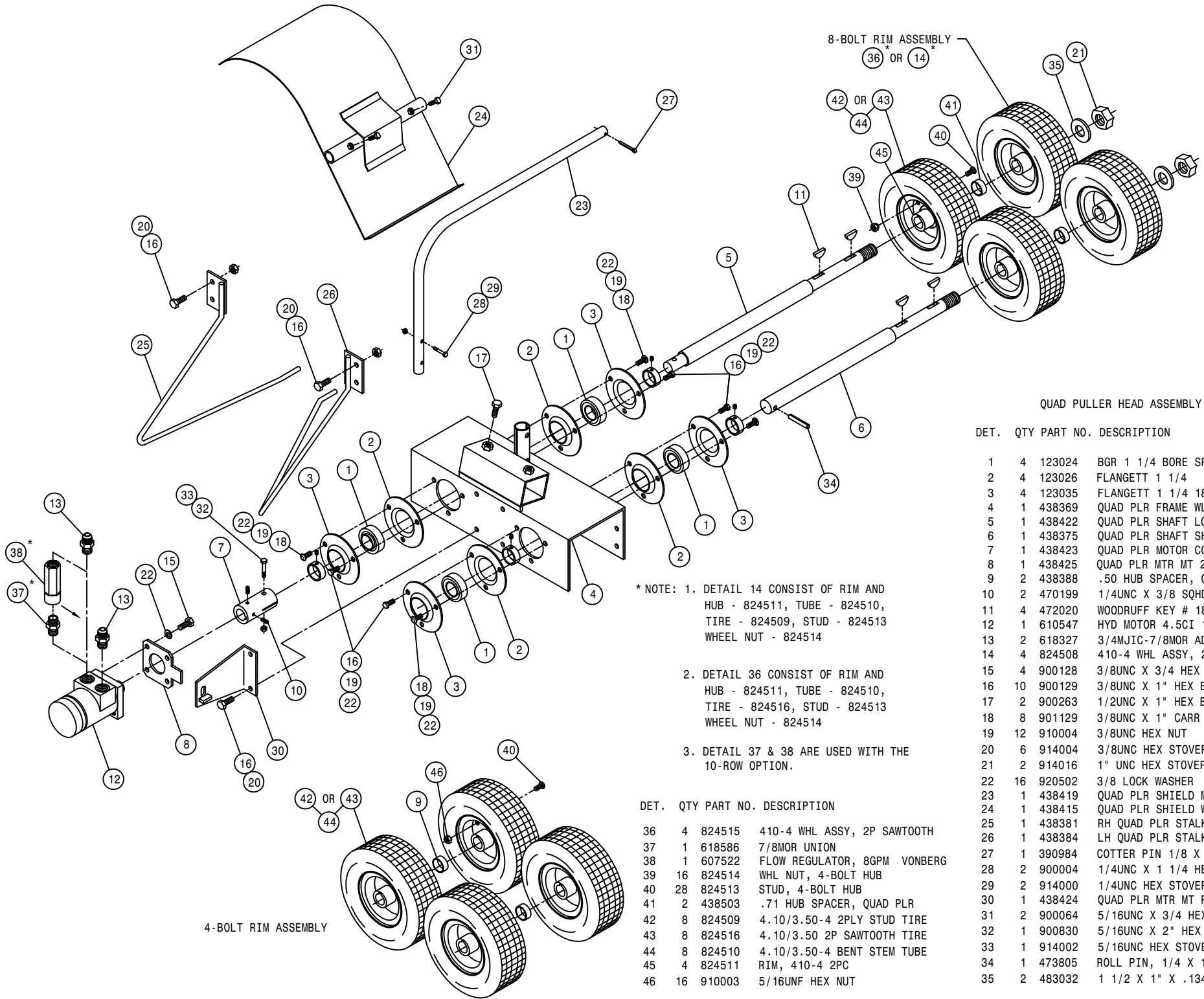

QUAD PULLER HEAD ASSEMBLY

DET.	QTY	PART NO.	DESCRIPTION
1	4	123024	BGR 1 1/4 BORE SPHERICL RELUB
2	4	123026	FLANGETT 1 1/4
3	4	123035	FLANGETT 1 1/4 180 DEG ZERK
4	1	438369	QUAD PLR FRAME WLD 200 90
5	1	438422	QUAD PLR SHAFT LONG 200 91
6	1	438375	QUAD PLR SHAFT SHORT 200 90
7	1	438423	QUAD PLR MOTOR COUPLER 200 91
8	1	438425	QUAD PLR MTR MT 200 91
9	2	438388	.50 HUB SPACER, QUAD PLR
10	2	470199	1/4UNC X 3/8 SQHD CUP SET SCR
11	4	472020	WOODRUFF KEY # 18 1/4 X 1 1/8
12	1	610547	HYD MOTOR 4.5CI 1IN SHFT
13	2	618327	3/4MJIC-7/8MOR ADPTR
14	4	824508	410-4 WHL ASSY, 2P STUD
15	4	900128	3/8UNC X 3/4 HEX BOLT
16	10	900129	3/8UNC X 1" HEX BOLT
17	2	900263	1/2UNC X 1" HEX BOLT
18	8	901129	3/8UNC X 1" CARR BOLT
19	12	910004	3/8UNC HEX NUT
20	6	914004	3/8UNC HEX STOVER NUT
21	2	914016	1" UNC HEX STOVER NUT
22	16	920502	3/8 LOCK WASHER
23	1	438419	QUAD PLR SHIELD MT TUBE 91
24	1	438415	QUAD PLR SHIELD WLD 200 91
25	1	438381	RH QUAD PLR STALK GUIDE WLD90
26	1	438384	LH QUAD PLR STALK GUIDE WLD90
27	1	390984	COTTER PIN 1/8 X 1 1/4
28	2	900004	1/4UNC X 1 1/4 HEX BOLT
29	2	914000	1/4UNC HEX STOVER NUT
30	1	438424	QUAD PLR MTR MT PLT WLD
31	2	900064	5/16UNC X 3/4 HEX BOLT
32	1	900830	5/16UNC X 2" HEX BOLT GR8
33	1	914002	5/16UNC HEX STOVER NUT
34	1	473805	ROLL PIN, 1/4 X 1 1/2
35	2	483032	1 1/2 X 1" X .134TH MACH WASH
36	4	824515	410-4 WHL ASSY, 2P SAWTOOTH
37	1	618586	7/8MOR UNION
38	1	607522	FLOW REGULATOR, 8GPM VONBERG
39	16	824514	WHL NUT, 4-BOLT HUB
40	28	824513	STUD, 4-BOLT HUB
41	2	438503	.71 HUB SPACER, QUAD PLR
42	8	824509	4.10/3.50-4 2PLY STUD TIRE
43	8	824516	4.10/3.50 2P SAWTOOTH TIRE
44	8	824510	4.10/3.50-4 BENT STEM TUBE
45	4	824511	RIM, 410-4 2PC
46	16	910003	5/16UNF HEX NUT

* NOTE: 1. DETAIL 14 CONSIST OF RIM AND HUB - 824511, TUBE - 824510, TIRE - 824509, STUD - 824513 WHEEL NUT - 824514

2. DETAIL 36 CONSIST OF RIM AND HUB - 824511, TUBE - 824510, TIRE - 824516, STUD - 824513 WHEEL NUT - 824514

3. DETAIL 37 & 38 ARE USED WITH THE 10-ROW OPTION.

4-BOLT RIM ASSEMBLY

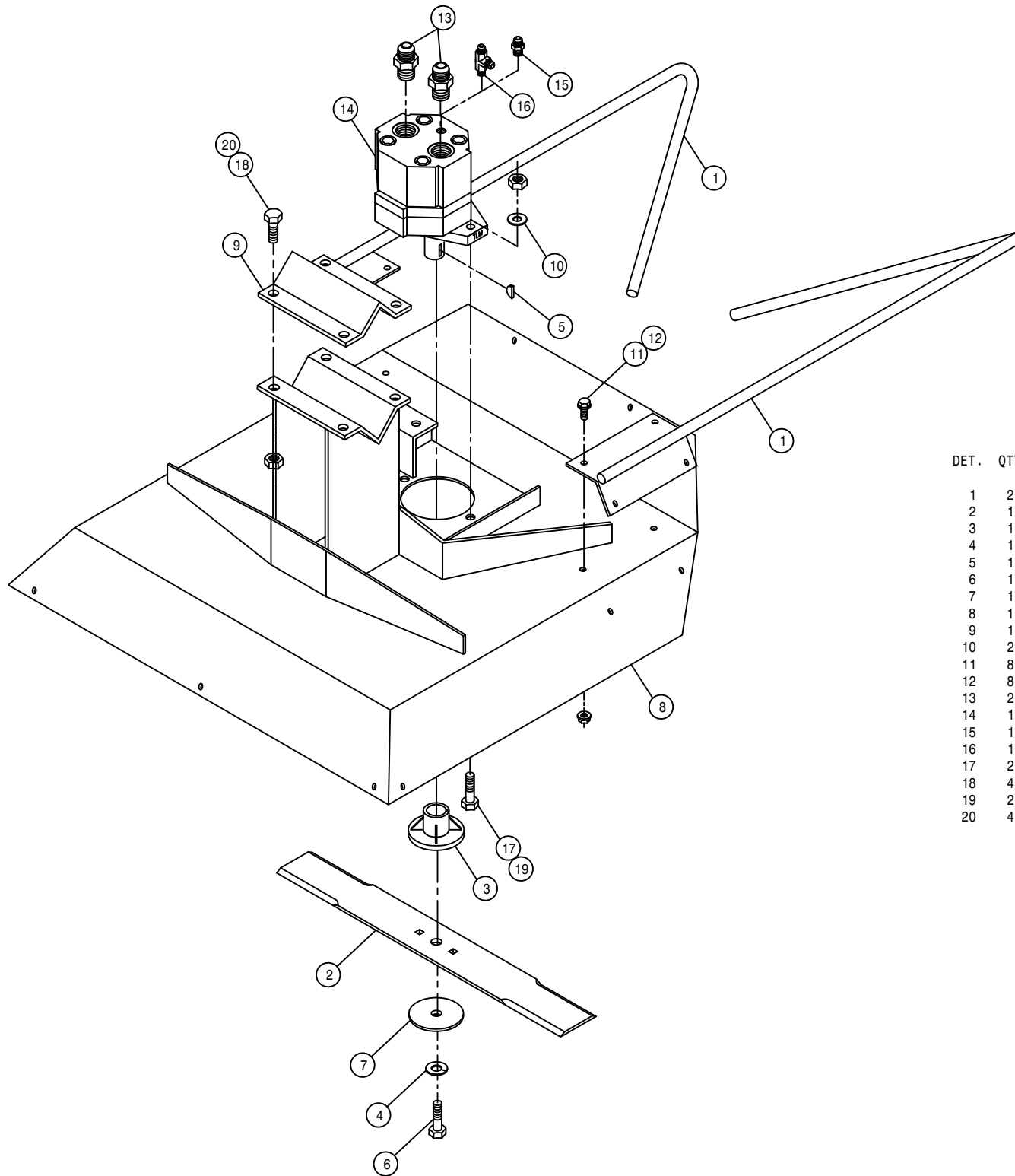

CUTTER HEAD ASSEMBLY

DET. QTY PART NO. DESCRIPTION

DET.	QTY	PART NO.	DESCRIPTION
1	2	002215	CUTR STALK GUIDE WLD 8200 85
2	1	002103	CUTR BLADE 18 IN
3	1	002104	CLUTCH BODY BLADE
4	1	002105	3/8 LOCK WASHER ZINC PLT
5	1	002106	WOODRUFF KEY #6 .156 X .625
6	1	002107	3/8UNF X 1 1/2 HEX BOLT CUTR
7	1	002108	STEEL WASHER CUTTER BLADE
8	1	002210	CUTR TOP WLD 8200 85
9	1	410016	RLR HANGER V 473
10	2	920002	3/8 SAE FLAT WASHER
11	8	470118	1/4UNC X 3/4 FLANGE HEX BOLT
12	8	470121	1/4UNC HEX FLANGE LOCK NUT
13	2	611125	3/4MJIC-3/4MOR ADPTR
14	1	610755	BARNES HYD MOTOR, D-SERIES 01
15	1	618530	9/16MJIC-1/8MNPT ADPTR
16	1	618546	1/8MNPT RUN TEE-9/16MJIC
17	2	900130	3/8UNC X 1 1/4 HEX BOLT
18	4	900265	1/2UNC X 1 1/2 HEX BOLT
19	2	914004	3/8UNC HEX STOVER NUT
20	4	914008	1/2UNC HEX STOVER NUT

LEFT SIDE OF OPERATOR

RIGHT SIDE OF OPERATOR

LEFT SIDE OF OPERATOR

RIGHT SIDE OF OPERATOR

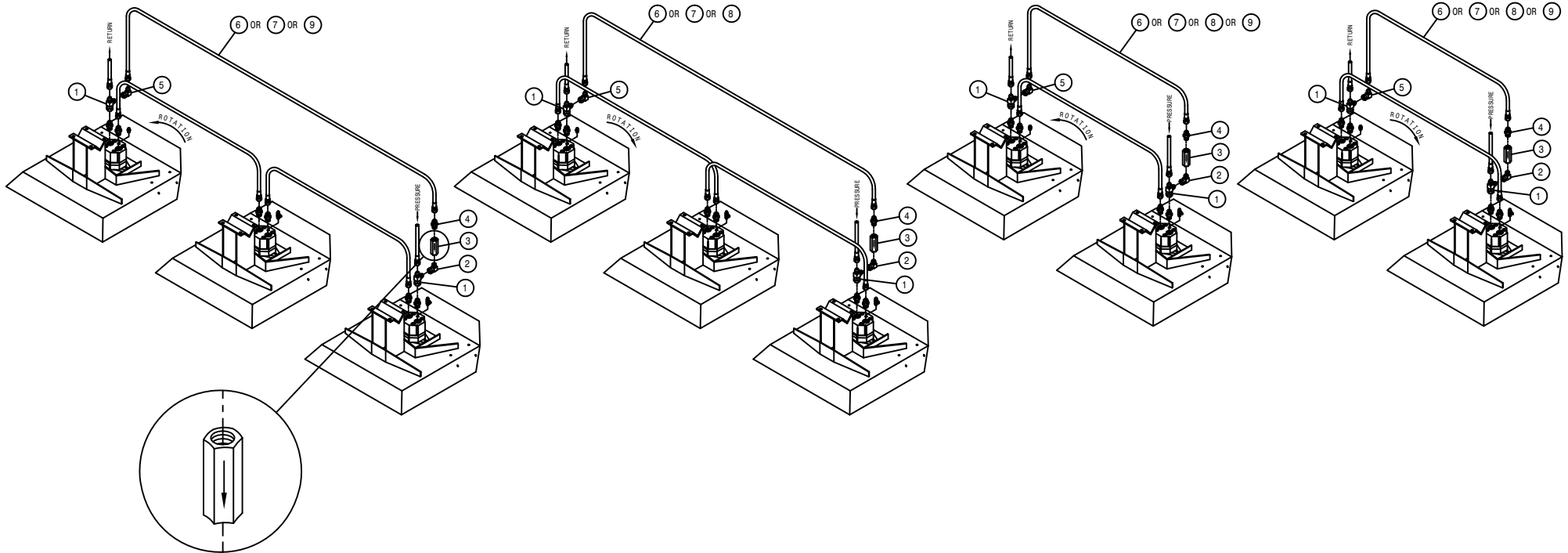

CUTTER CHECK VALVE HYDRAULIC SCHEMATIC

DET. QTY PART NO. DESCRIPTION

1	2	618451	3/4FJIC SW RUN TEE-3/4MJIC	
2	1	618620	3/4FJX-90-1/2MNPT ADPTR	
3	1	690338	LINE CHECK VALVE HYD .50NPT	
4	1	611147	3/4MJIC-1/2MNPT ADPTR	
5	1	618609	3/4MJIC-90-3/4FJIC SWIV LBO	
6	1	614375	08C1T-08FJX-08FJX-177	H/A
7	1	616057	08C1T-08FJX-08FJX-88	H/A
8	1	614368	08C1T-08FJX-08FJX-60	H/A
9	1	614384	08C1T-08FJX-08FJX-237	H/A

NOTE: LISTING IS FOR ONE GROUP OF CUTTER HEADS.

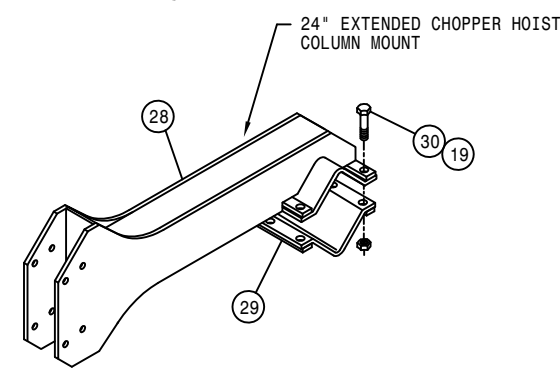
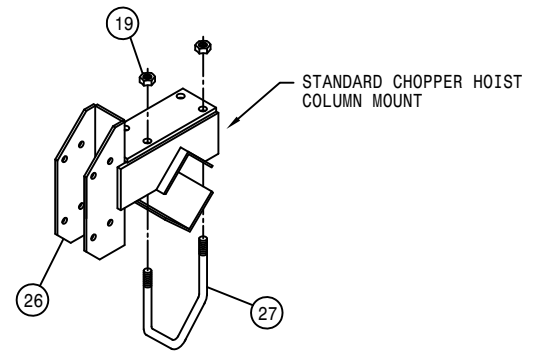
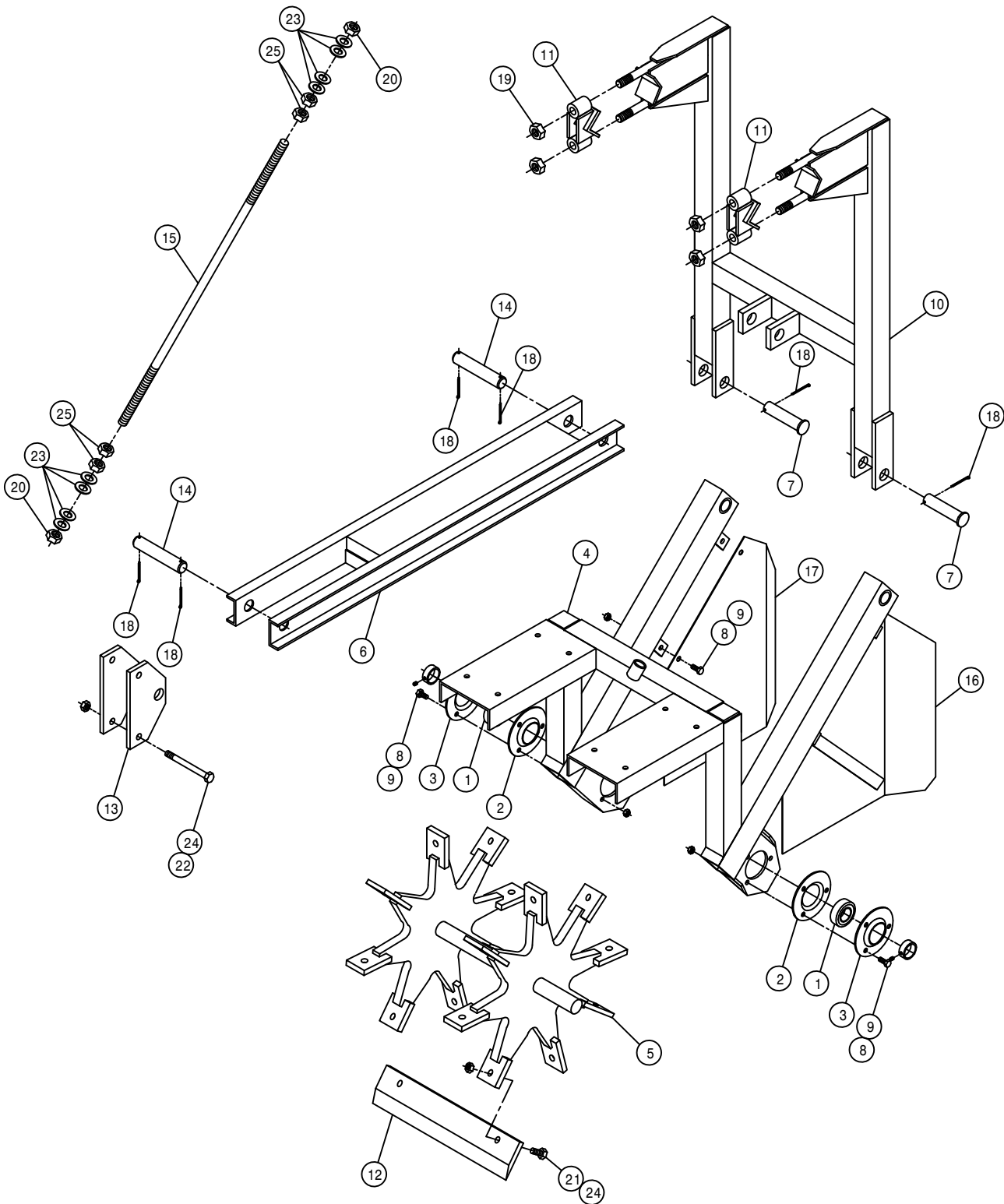

15" MALE ROW CHOPPER ASSEMBLY

DET. QTY PART NO. DESCRIPTION

DET.	QTY	PART NO.	DESCRIPTION
1	2	123024	BGR 1 1/4 BORE SPHERICL RELUB
2	2	123026	FLANGETT 1 1/4
3	2	123035	FLANGETT 1 1/4 180 DEG ZERK
4	1	270814	LWR FRAME WLD MALE ROW CHOP
5	1	270860	BLADE MT WHL WLD, CHOPPER 92
6	1	270852	LWR LIFT ARM WLD MALE ROW CHOP 91
7	2	472012	CLEVIS PIN, 1.00 X 3.25 PLT
8	10	900129	3/8UNC X 1" HEX BOLT
9	10	914004	3/8UNC HEX STOVER NUT
10	1	270855	UPR FRAME WLD MALE ROW CHOP91
11	2	270833	TOOL BAR CLAMP WLD MALE CHOP
12	8	270838	CHOPPER BLADE 8131 STEEL TREA
13	2	270842	LWR LIFT ARM MTG PLT
14	2	270843	LIFT ARM PIN MALE ROW CHOPPER
15	1	270844	ADJ ROD MALE ROW CHOPPER
16	1	270845	RH SHLD WLD MALE ROW CHOPPER
17	1	270846	LH SHLD WLD MALE ROW CHOPPER
18	6	470162	COTTER PIN 3/16 X 1 1/2 SQCUT
19	14	914010	5/8UNC HEX STOVER NUT
20	2	914012	3/4UNC HEX STOVER NUT
21	16	900265	1/2UNC X 1 1/2 HEX BOLT
22	2	900275	1/2UNC X 4 1/2 HEX BOLT
23	8	920006	3/4 SAE FLAT WASHER
24	18	914008	1/2UNC HEX STOVER NUT
25	4	910012	3/4UNC HEX NUT
26	1	438367	HOIST COL MT BRKT WLD 200 90
27	2	438293	5/8UNC X 6 1/4 CTR U-BOLT TRI
28	1	438665	24" HOIST COL MT BRKT WLD
29	1	438671	24" HOIST COL MT V-PLT KPR WLD
30	6	900337	5/8UNC X 2 3/4 HEX BOLT

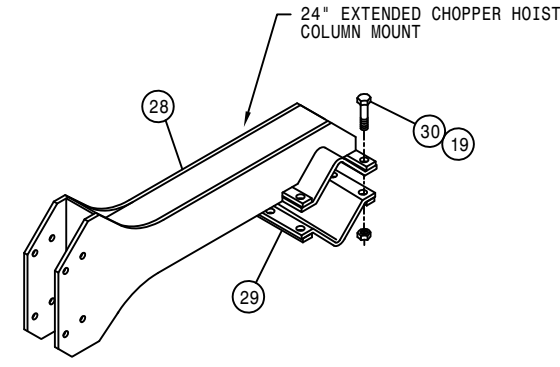
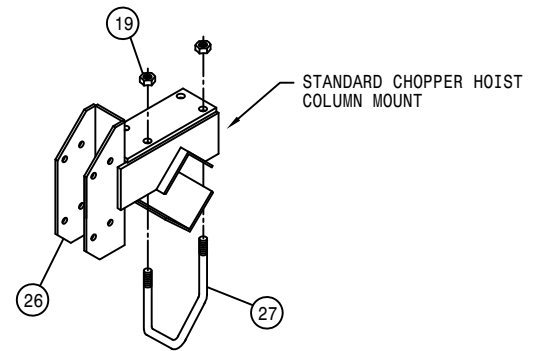
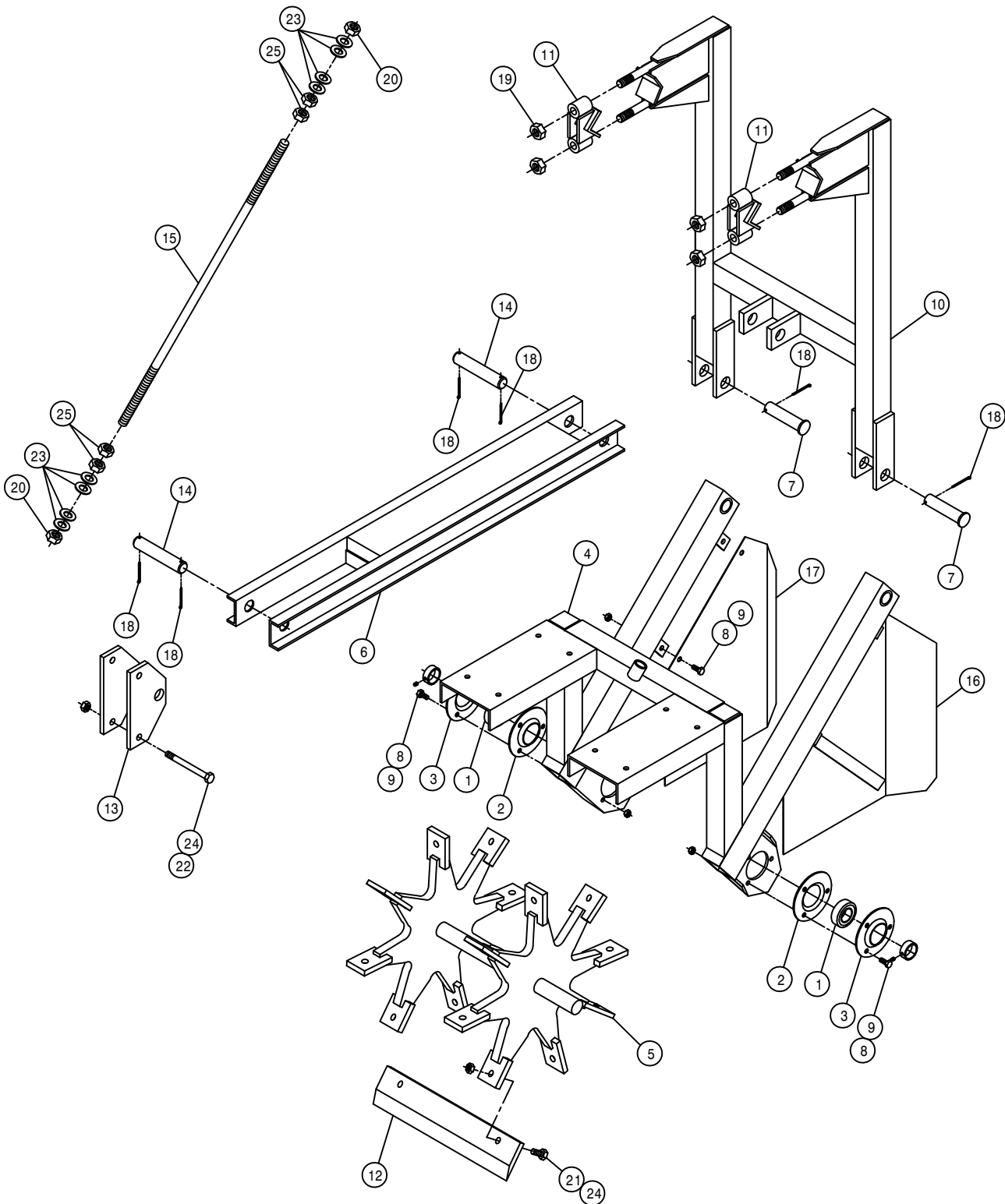

20" MALE ROW CHOPPER ASSEMBLY

DET.	QTY	PART NO.	DESCRIPTION
1	2	123024	BGR 1 1/4 BORE SPHERICL RELUB
2	2	123026	FLANGETT 1 1/4
3	2	123035	FLANGETT 1 1/4 180 DEG ZERK
4	1	270872	LWR FRAME WLD,20"MALE CHOPR95
5	1	270874	BLADE MT WHL WLD,20"CHOPR 95
6	1	270852	LWR LIFT ARM WLD MALE CHOP 91
7	2	472012	CLEVIS PIN, 1.00 X 3.25 PLT
8	10	900129	3/8UNC X 1" HEX BOLT
9	10	914004	3/8UNC HEX STOVER NUT
10	1	270876	UPR FRAME WLD,20"MALE CHOPR95
11	2	270833	TOOL BAR CLAMP WLD MALE CHOP
12	8	270866	CHOPPER BLADE,MALE ROW,20" 95
13	2	270842	LWR LIFT ARM MTG PLT
14	2	270843	LIFT ARM PIN MALE ROW CHOPPER
15	1	270867	ADJ ROD WLD,MALE ROW CHOPR 95
16	1	270845	RH SHLD WLD MALE ROW CHOPPER
17	1	270846	LH SHLD WLD MALE ROW CHOPPER
18	6	470162	COTTER PIN 3/16 X 1 1/2 SQ CUT
19	14	914010	5/8UNC HEX STOVER NUT
20	2	914012	3/4UNC HEX STOVER NUT
21	16	900265	1/2UNC X 1 1/2 HEX BOLT
22	2	900275	1/2UNC X 4 1/2 HEX BOLT
23	8	920006	3/4 SAE FLAT WASHER
24	18	914008	1/2UNC HEX STOVER NUT
25	4	910012	3/4UNC HEX NUT
26	1	438367	HOIST COL MT BRKT WLD 200 90
27	2	438293	5/8UNC X 6 1/4 CTR U-BOLT TRI
28	1	438665	24" HOIST COL MT BRKT WLD
29	1	438671	24" HOIST COL MT V-PLT KPR WLD
30	6	900337	5/8UNC X 2 3/4 HEX BOLT

MALE ROW 4-BLADE CUTTER ASSEMBLY

DET. QTY PART NO. DESCRIPTION

1	1	474020	1 1/4 SHAFT SET COLLAR
2	1	123024	BGR 1 1/4 BORE SPHERICL RELUB
3	1	123026	FLANGETT 1 1/4
4	1	123035	FLANGETT 1 1/4 180 DEG ZERK
5	1	270880	RH 4-BLADE CUTTER FRAME WLD95
6	1	270881	LH 4-BLADE CUTTER FRAME WLD95
7	1	270896	LWR BRG MT WLD,4-BLD CUTR 95
8	1	270902	BLADE SHAFT,4-BLD CUTR 95
9	4	270903	BLADE MT HUB,4-BLD CUTR 95
10	8	270904	CUTTER BLADE,4-BLD CUTR 95
11	8	270905	UPPER BLADE SUPP,4-BLD CUTR95
12	2	470060	5/16UNC X 3/8 SET SCR
13	1	270907	CUTTER ADPT WLD,4-BLD CUTR 95
14	1	270910	CUTTER MT WLD,4-BLD CUTR 95
15	1	270913	RH ADJ ANG,4-BLD CUTR 95
16	1	270914	LH ADJ ANG,4-BLD CUTR 95
17	1	270915	RH SHIELD WLD,4-BLD CUTR 95
18	1	270916	LH SHIELD WLD,4-BLD CUTR 95
19	1	270923	DEFLECTOR SHLD,4-BLD CUTR 95
20	8	470057	5/16 X 1/2 LG SQ HD SET SCR
21	4	470121	1/4UNC HEX FLANGE LOCK NUT
22	4	470122	1/4UNC X 1/2 FLANGE HEX BOLT
23	1	492084	CHAIN FOR 4016 CHAIN COUPLER
24	1	492092	CHAIN CPLR 5/8 BORE 5/32 KWY
25	1	492091	CHAIN CPLR 1 1/4 BORE .25 KWY
26	1	610510	CESSNA GEAR MOTOR 1.48CI
27	1	610597	PRESS COMP FIXED FLO REG 18G
28	1	611121	9/16MJIC-1/4MNPT ADPTR
29	2	611145	3/4MJIC-90-1/2MNPT LBO
30	2	615626	08C1T-08FJX-08FJX-15 H/A
31	4	618451	3/4FJIC SW RUN TEE-3/4MJIC
32	1	618469	3/4MJIC-1 1/16MOR ADPTR
33	1	618474	3/4MJIC-90-1 1/16MOR LBO
34	1	618578	1 1/16FJIC SWIV-1 1/16MOR
35	1	690338	LINE CHECK VALVE HYD .50NPT
36	1	470052	1/4-20X1/2 AL HD SET SC CUP
37	24	900066	5/16UNC X 1 1/4 HEX BOLT
38	23	900129	3/8UNC X 1" HEX BOLT
39	5	900130	3/8UNC X 1 1/4 HEX BOLT
40	2	900263	1/2UNC X 1" HEX BOLT
41	2	900270	1/2UNC X 3" HEX BOLT
42	1	900273	1/2UNC X 3 3/4 HEX BOLT
43	1	900408	3/4UNC X 3 1/2 HEX BOLT
44	2	914000	1/4UNC HEX STOVER NUT
45	28	914004	3/8UNC HEX STOVER NUT
46	3	914008	1/2UNC HEX STOVER NUT
47	1	914012	3/4UNC HEX STOVER NUT
48	8	920001	5/16 SAE FLAT WASHER
49	8	920501	5/16 LOCK WASHER
50	1	270924	GUIDE MT WLD,4-BLD CUTR 95
51	1	270928	RH STALK GUIDE WLD,4-BLD CUTR
52	1	270929	LH STALK GUIDE WLD,4-BLD CUTR
53	2	900005	1/4UNC X 1 1/2 HEX BOLT
54	2	900069	5/16UNC X 2" HEX BOLT
55	18	914002	5/16UNC HEX STOVER NUT
56	2	920001	5/16 SAE FLAT WASHER
57	5	472020	WOODRUFF KEY # 18 1/4 X 1 1/8
58	1	611127	1 1/16MJIC-1 1/16MOR ADPTR
59	1	200015	.75 OD X 11GA WA X .38LG C/L
60	1	123050	1.25 PILLOW BLOCK BEARING,FLG

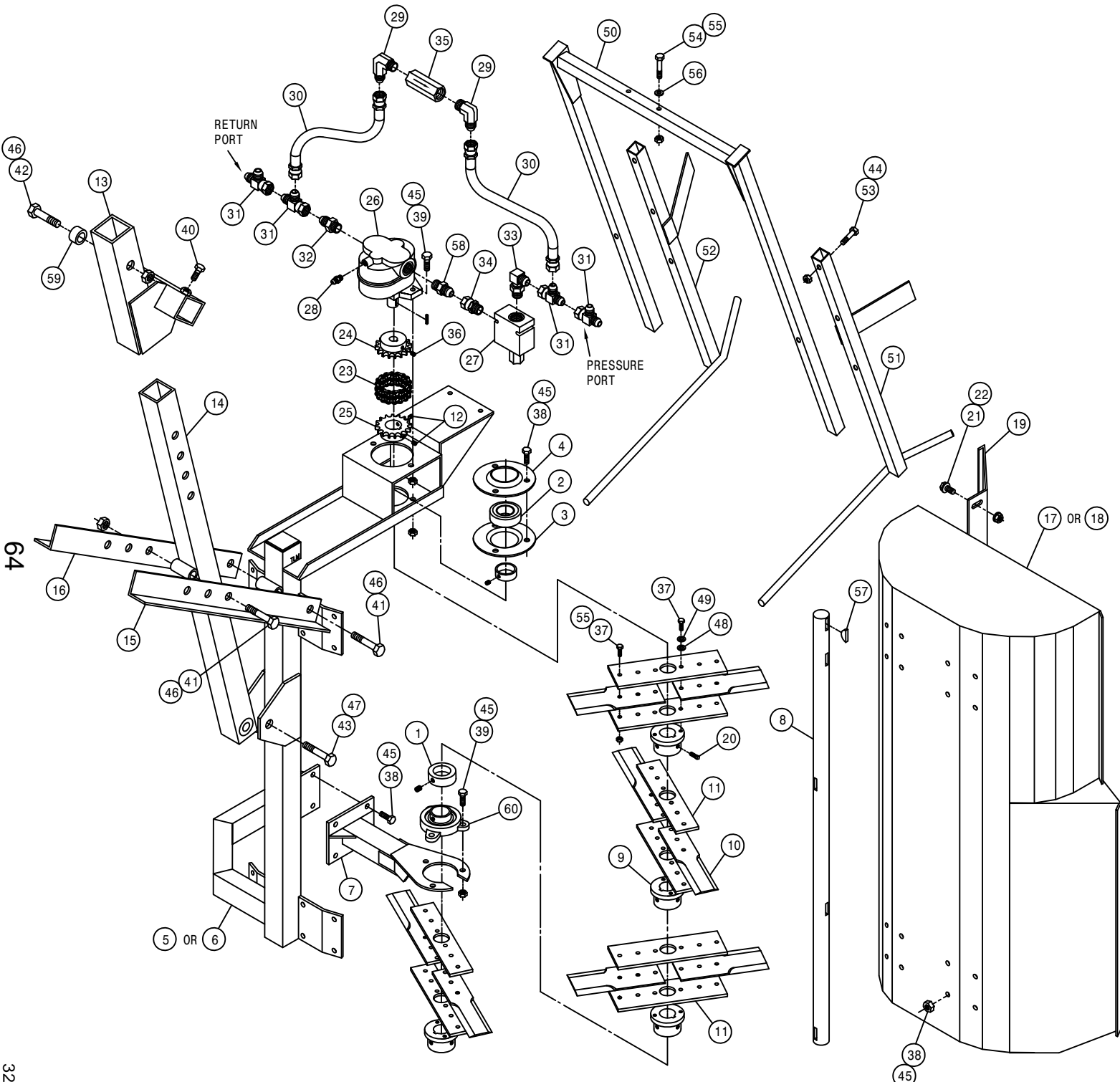

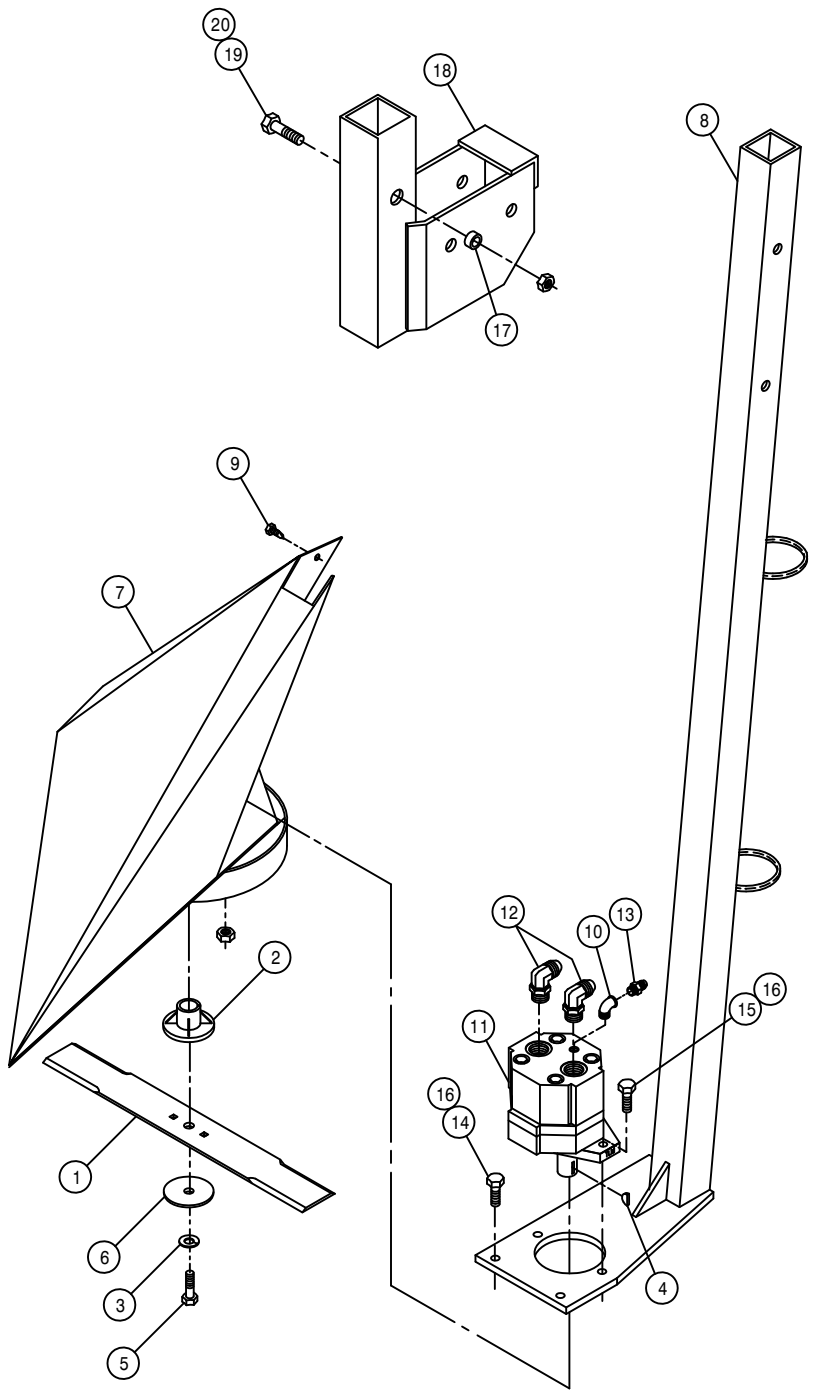

MALE CORN CUTTER ASSEMBLY

DET.	QTY	PART NO.	DESCRIPTION
	1	002103	CUTR BLADE 18 IN
	1	002104	CLUTCH BODY BLADE
	3	002105	3/8 LOCK WASHER ZINC PLT
	4	002106	WOODRUFF KEY #6 .156 X .625
	5	002107	3/8UNC X 1 1/2 HEX BOLT CUTR
	6	002108	STEEL WASHER CUTTER BLADE
	7	270800	MALE CORN CUTR WLD
	8	270805	MALE CORN CUTR DROP TUBE WLD
	9	472349	1/4 X 3/4 20THD-IN TEK TYPE
	10	500900	BLK PIPE ST EL 90DEG .125NPT
	11	610755	BARNES HYD MOTOR, D-SERIES 01
	12	618241	3/4MJC-90-3/4MOR LBO
	13	618530	9/16MJC-1/8MNP ADPTR
	14	900129	3/8UNC X 1" HEX BOLT
	15	900132	3/8UNC X 1 3/4 HEX BOLT
	16	914004	3/8UNC HEX STOVER NUT
	17	200015	.75 OD X 11GA WA X .38LG C/L
	18	270809	MALE CUTR ADPTR BRKT WLD 83
	19	900273	1/2UNC X 3 3/4 HEX BOLT
	20	914008	1/2UNC HEX STOVER NUT

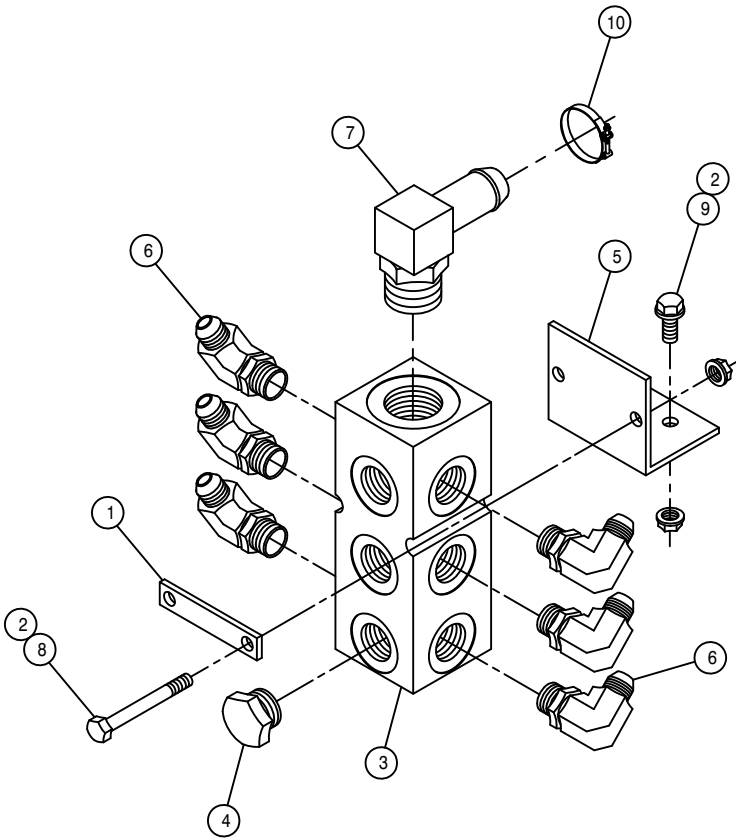

CUTTER CASE DRAIN MANIFOLD ASSEMBLY

DET. QTY PART NO. DESCRIPTION

1	1	438729	CUTTER RETURN MANIF MT KEEPER
2	4	470121	1/4UNC HEX FLANGE LOCK NUT
3	1	606021	HYD RETURN MANIF,3/4FOR,9-PORT
4	3	611159	3/4MOR PLUG
5	1	615755	204 CASE DRAIN MANIFOLD MT 02
6	6	618115	9/16MJC-90-3/4MOR LBO
7	1	618118	3/4 HOSE BARB-90-1 1/16MOR
8	2	900008	1/4UNC X 2 1/2 HEX BOLT
9	2	470118	1/4UNC X 3/4 FLANGE HEX BOLT
10	1	520137	1.12/1.25 T-BOLT HOSE CLAMP

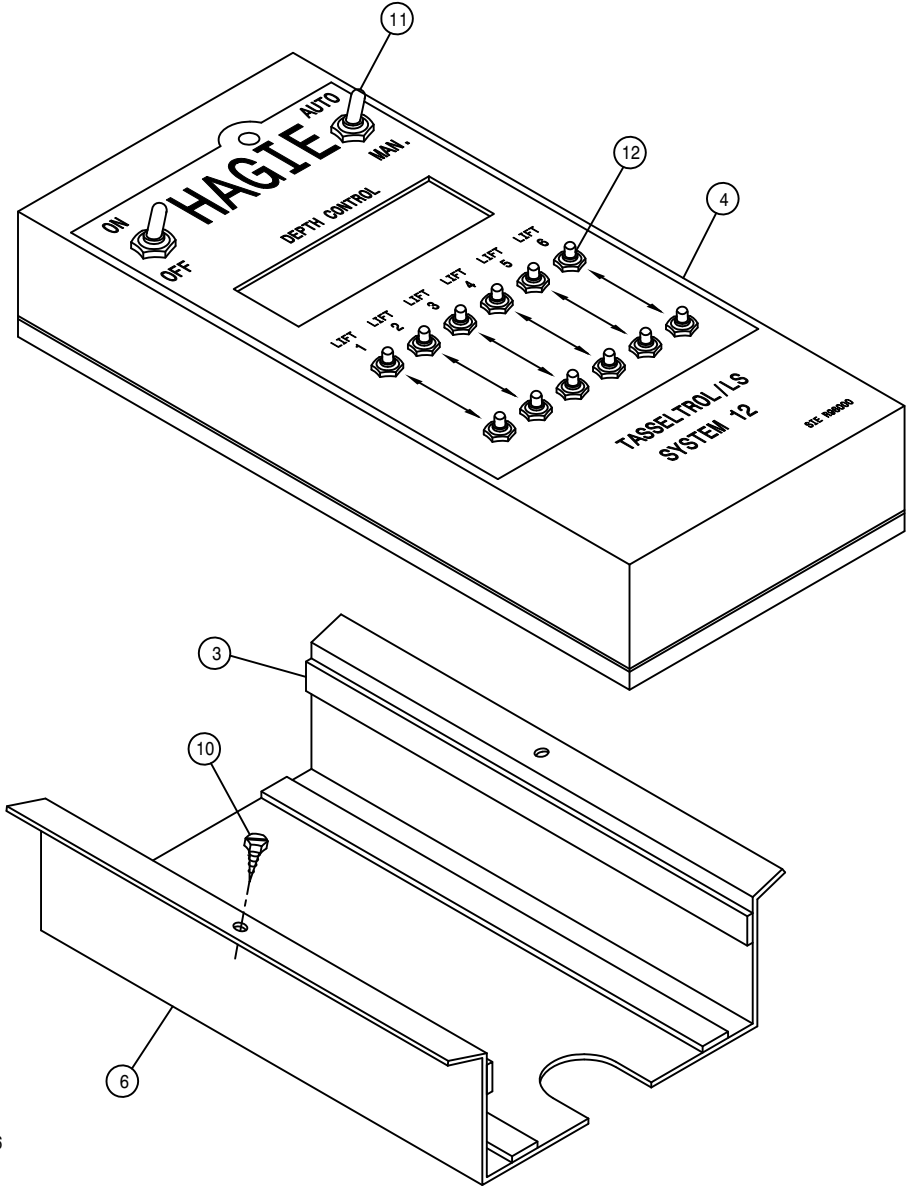
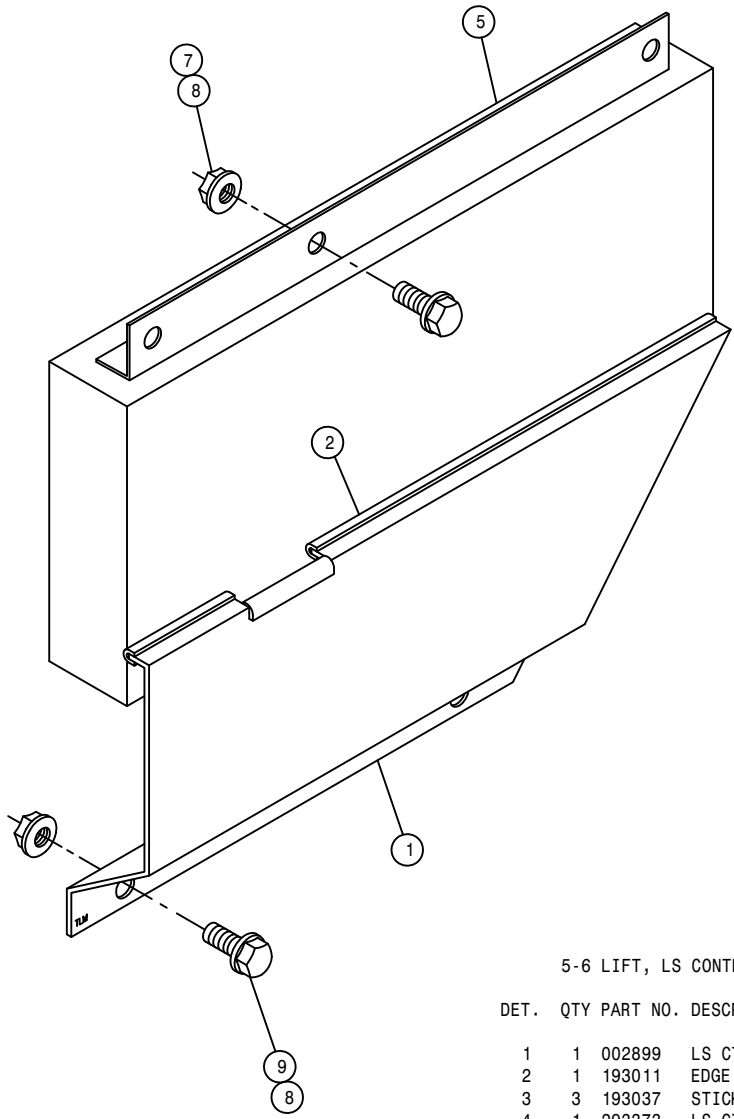

5-6 LIFT, LS CONTROL BOX ASSEMBLY

DET.	QTY	PART NO.	DESCRIPTION
	1	002899	LS CTRL BOX CONNECTOR SHLD 96
	1	193011	EDGE GUARD, BLK
	3	193037	STICKERTITE 1/8 X 3/4
	4	293373	LS CTRL 6L DISPLAY BOX ASSY
	5	293374	LS CTRL 6L CABLE BOX ASSY
	6	342297	LS CTRL 6L DISPLAY BOX MT
	7	470118	1/4UNC X 3/4 FLANGE HEX BOLT
	8	470121	1/4UNC HEX FLANGE LOCK NUT
	9	470122	1/4UNC X 1/2 FLANGE HEX BOLT
	10	473902	NO 8 X 1/2 PAN HD MET SC
	11	470001	RUBBER BOOT W NUT FOR 298012
	12	293255	SWITCH BOOT,PUSHBUTTON,1/4-40

LS MANUAL SWITCH ASSEMBLY

LS CONTROL BOX ASSEMBLY

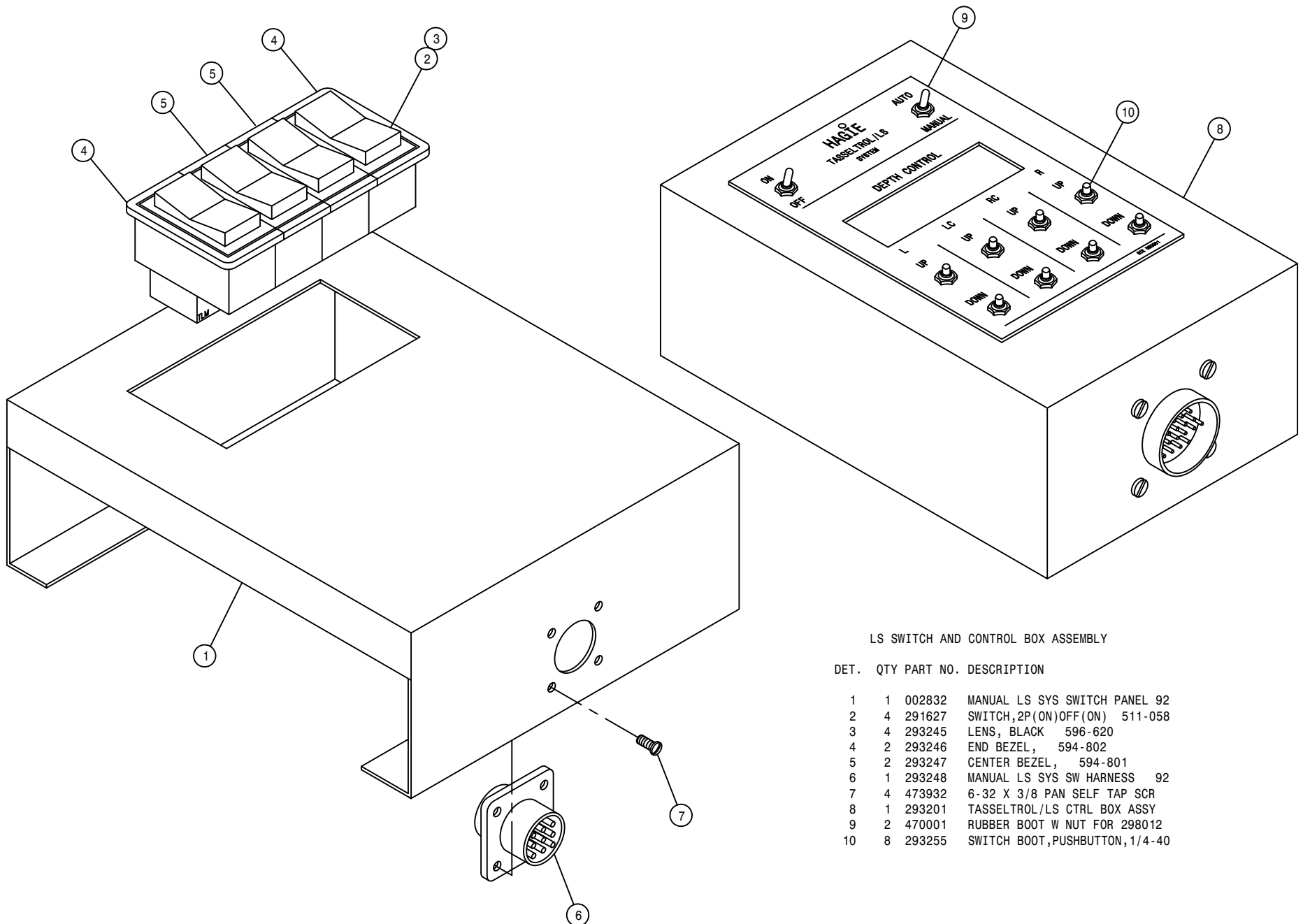

LS SWITCH AND CONTROL BOX ASSEMBLY

DET. QTY PART NO. DESCRIPTION

1	1	002832	MANUAL LS SYS SWITCH PANEL 92
2	4	291627	SWITCH,2P(ON)OFF(ON) 511-058
3	4	293245	LENS, BLACK 596-620
4	2	293246	END BEZEL, 594-802
5	2	293247	CENTER BEZEL, 594-801
6	1	293248	MANUAL LS SYS SW HARNESS 92
7	4	473932	6-32 X 3/8 PAN SELF TAP SCR
8	1	293201	TASSELTROL/LS CTRL BOX ASSY
9	2	470001	RUBBER BOOT W NUT FOR 298012
10	8	293255	SWITCH BOOT,PUSHBUTTON,1/4-40

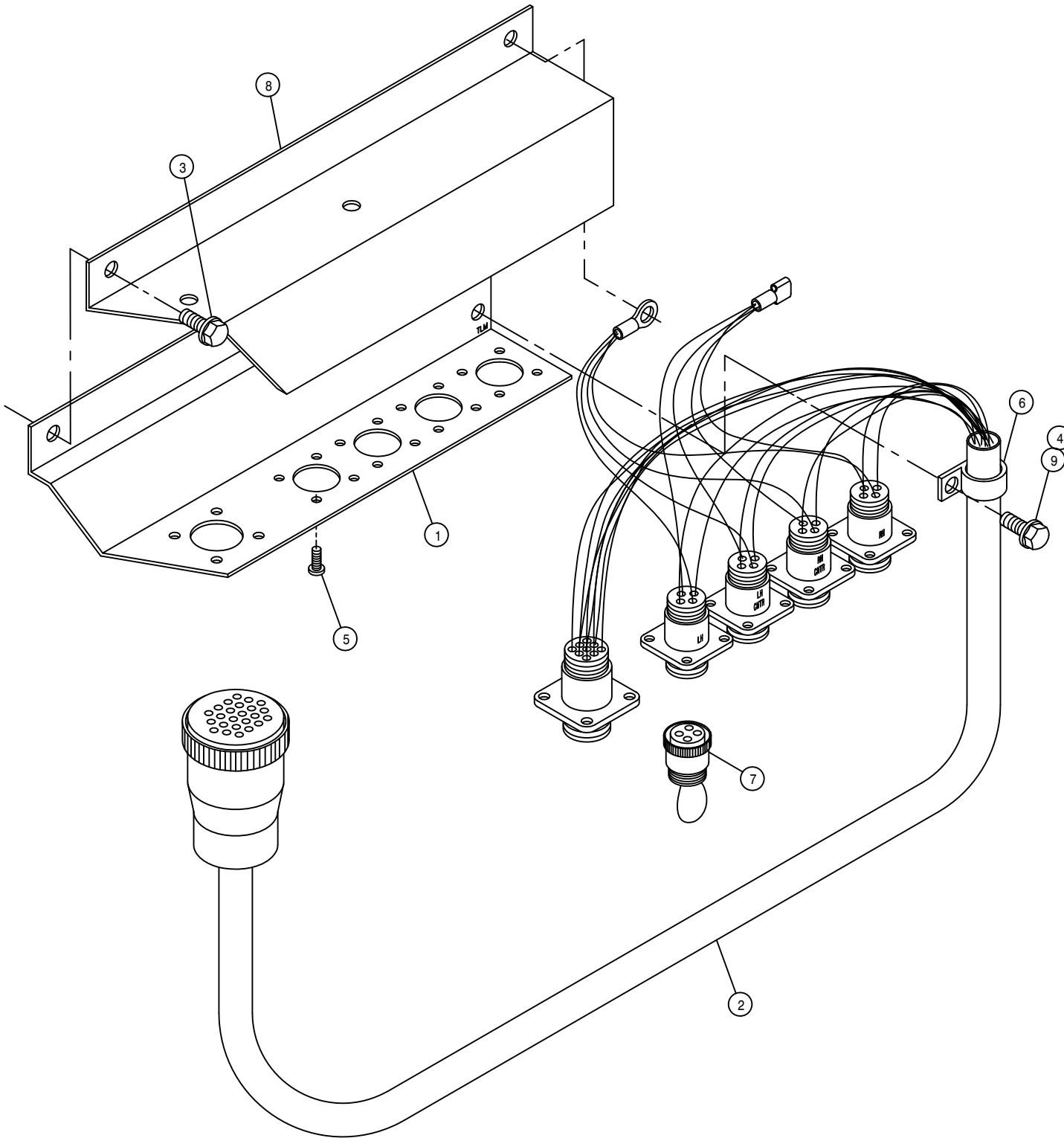

LS RECEPTACLE ASSEMBLY

DET. QTY PART NO. DESCRIPTION

1	1	002777	T-TROL/LS RECEPTACLE MT
2	1	293200	MAIN CONTROL WIRE ASSY LS 90
3	2	470118	1/4UNC X 3/4 FLANGE HEX BOLT
4	1	470121	1/4UNC HEX FLANGE LOCK NUT
5	20	473932	6-32 X 3/8 PAN SELF TAP SCR
6	1	520118	CUSH HOSE CLAMP 1/2D X 1/2W
7	1	293211	JUMPER PLUG, T-TROL/LS SYS
8	1	002879	RECEPTACLE MT COVER, 204 94
9	1	470122	1/4UNC X 1/2 FLANGE HEX BOLT

NOTE: DETAIL 7 IS USED (1) WITH 3-LIFT OPTION AND (2) WITH 2-LIFT OPTION.

70

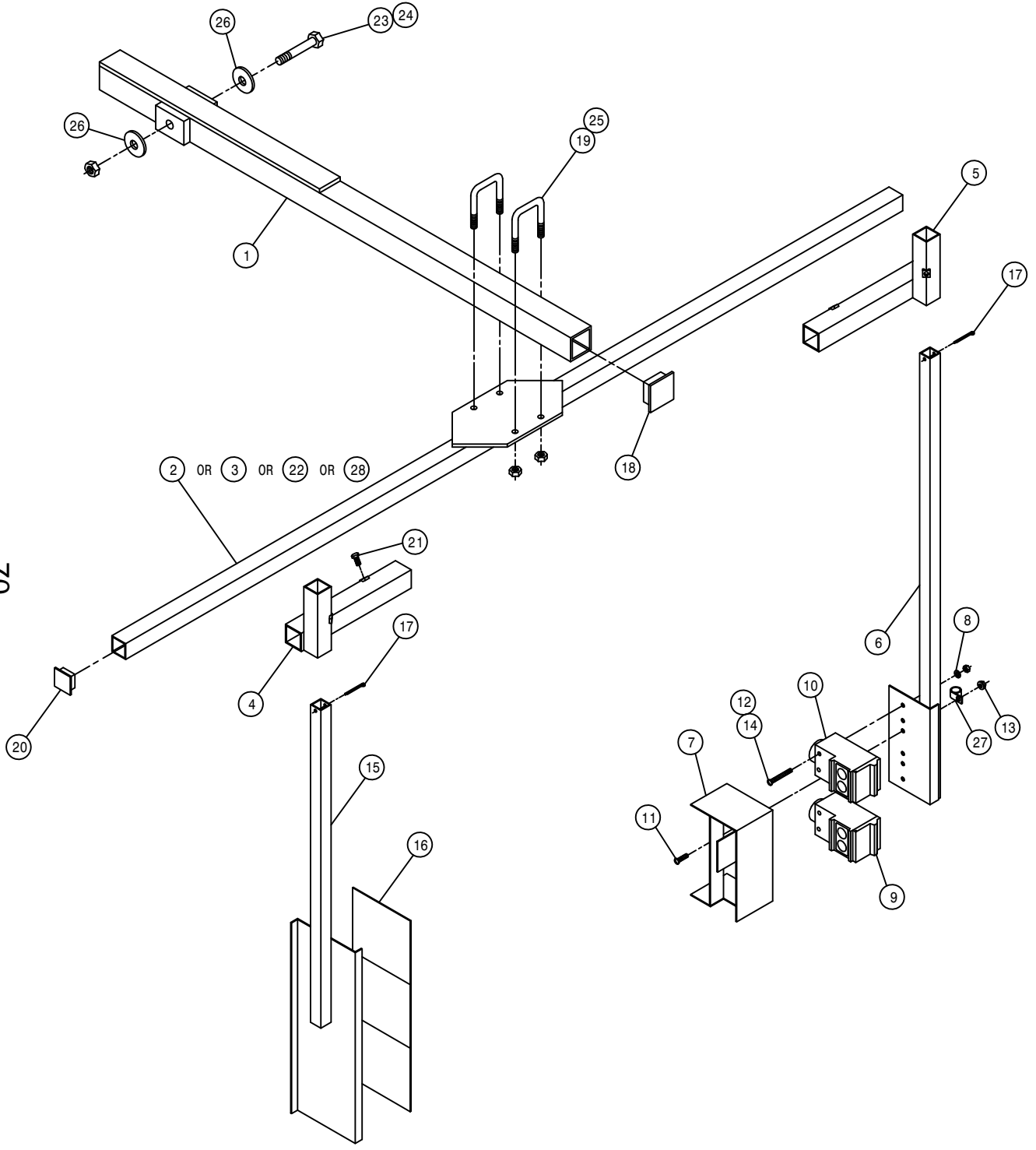

LS SENSOR ASSEMBLY

DET.	QTY	PART NO.	DESCRIPTION	
1	1	002813	SENSOR ARM WELD 200 DET	92
2	1	002834	LS CROSSTUBE WLD 10-12R	92
3	1	002709	LS CROSSTUBE WLD	90
4	1	002712	LS REFLECTOR SLIDE MT WLD	90
5	1	002713	LS SENSOR SLIDE MT WLD	90
6	1	002839	LS 42GRU PHOTOSW SENSR MT WLD	
7	1	002841	LS 42GRU SENSOR SHIELD WLD	
8	2	920510	#10 LOCK WASHER	
9	1	293258	LWR LS 9000 SENSOR ASSY, FEM	
10	1	293259	UPR LS 9000 SENSOR ASSY, MALE	
11	2	903883	10-32 X 1/2 SLT RDHD MACH SCR	
12	2	910027	10-32 HEX NUT	
13	2	470175	10-32 HEX FLANGE LOCK NUT	
14	4	903902	10-32 X 2" SLT RD HD MACH SCR	
15	1	002723	LS REFLECTOR MT WLD	90
16	3	650297	REFLECTIVE TAPE,4 X 4, RTC4-4P	
17	2	390984	COTTER PIN 1/8 X 1 1/4	
18	1	473943	FINISH PLUG 1 1/2 SQ	
19	2	473949	5/16UNC-1 9/16ID-1 15/16U-BOLT	
20	2	629727	FINISH PLUG FOR 1"SQ X 16 GA	
21	4	900000	1/4UNC X 1/2 HEX BOLT	
22	1	002876	LS CROSSTUBE WLD, 62"	94
23	1	900275	1/2UNC X 4 1/2 HEX BOLT	
24	1	914008	1/2UNC HEX STOVER NUT	
25	4	914002	5/16UNC HEX STOVER NUT	
26	2	002815	SENSOR ARM WASH, NYL	
27	1	520117	CUSH HOSE CLAMP 5/8D X 1/2W	
28	1	003047	LS CROSSTUBE WLD, 52CM	04

2-3-4 LIFT, DEPTH COMMAND SWITCH ASSEMBLY

DET. QTY PART NO. DESCRIPTION

DET.	QTY	PART NO.	DESCRIPTION
1	1	002744	SWITCH BOX, DEPTH CMD
2	1	002745	SWITCH BOX MT, DEPTH CMD
3	2	470122	1/4UNC X 1/2 FLANGE HEX BOLT
4	1	658174	RUBBER BUMPER, 1.0000D .500GD
5	1	291602	FUSE 10 AMP
6	4	293172	TOGGLE SWITCH DPDT W/JUMPERS
7	1	298011	FUSE HOLDER
8	4	470001	RUBBER BOOT W NUT FOR 298012
9	1	473914	GROMMET, .562ID .062GW .812GD
10	4	473829	3MM-0.50 X 16MM PANHEAD SCREW
11	2	470121	1/4UNC HEX FLANGE LOCK NUT

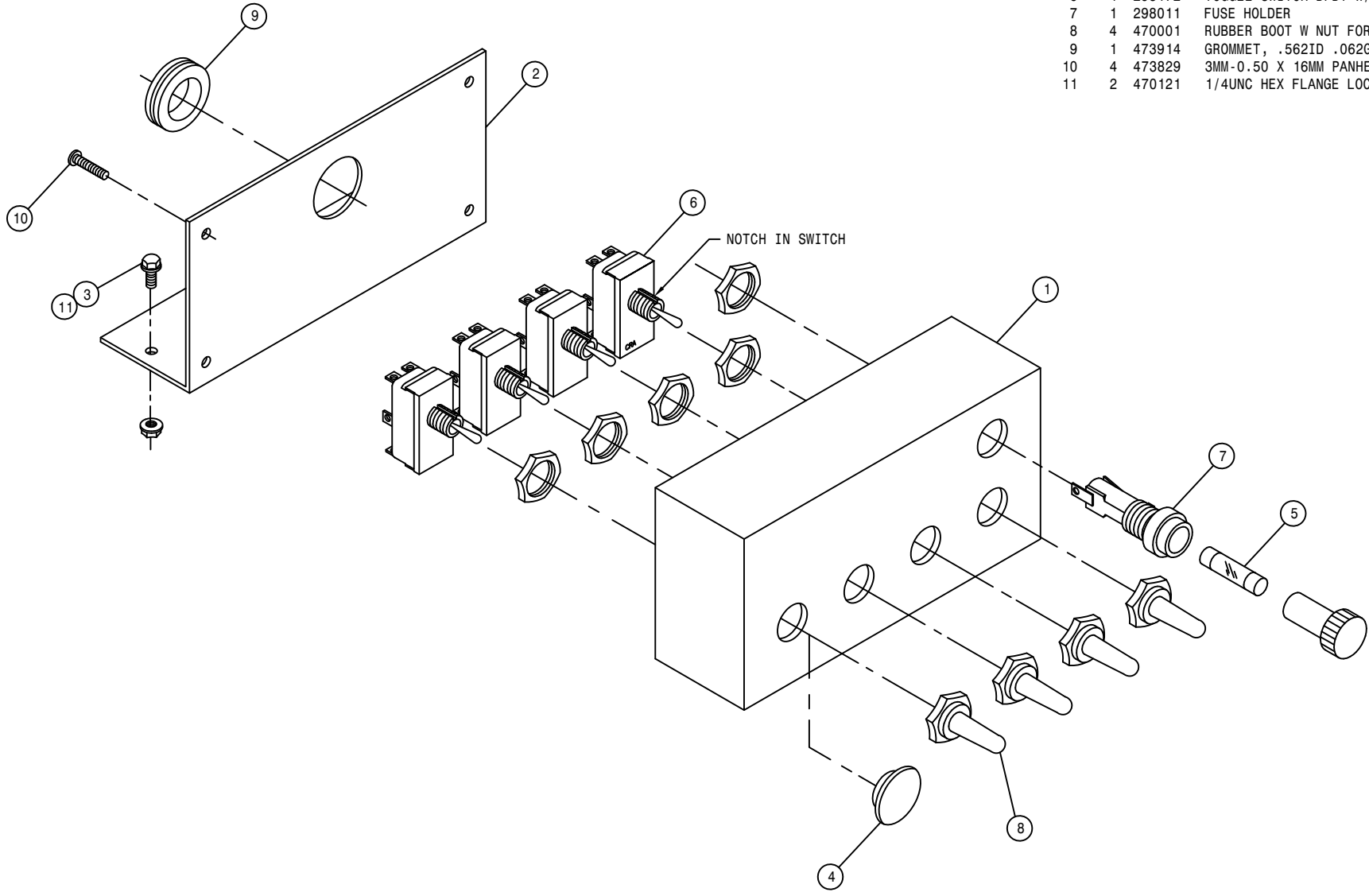

71

5-6 LIFT, DEPTH COMMAND SWITCH ASSEMBLY

DET. QTY PART NO. DESCRIPTION

DET.	QTY	PART NO.	DESCRIPTION
1	1	002896	SWITCH BOX, 5/6L DEPTH CMD 96
2	1	002897	SWITCH BOX MT, 5/6L DEPTH CMD
3	2	470122	1/4UNC X 1/2 FLANGE HEX BOLT
4	1	658174	RUBBER BUMPER, 1.0000D .500GD
5	1	291602	FUSE 10 AMP
6	6	293172	TOGGLE SWITCH DPDT W/JUMPERS
7	1	298011	FUSE HOLDER
8	6	470001	RUBBER BOOT W NUT FOR 298012
9	1	473914	GROMMET, .562ID .062GW .812GD
10	4	473829	3MM-0.50 X 16MM PANHEAD SCREW
11	2	470121	1/4UNC HEX FLANGE LOCK NUT

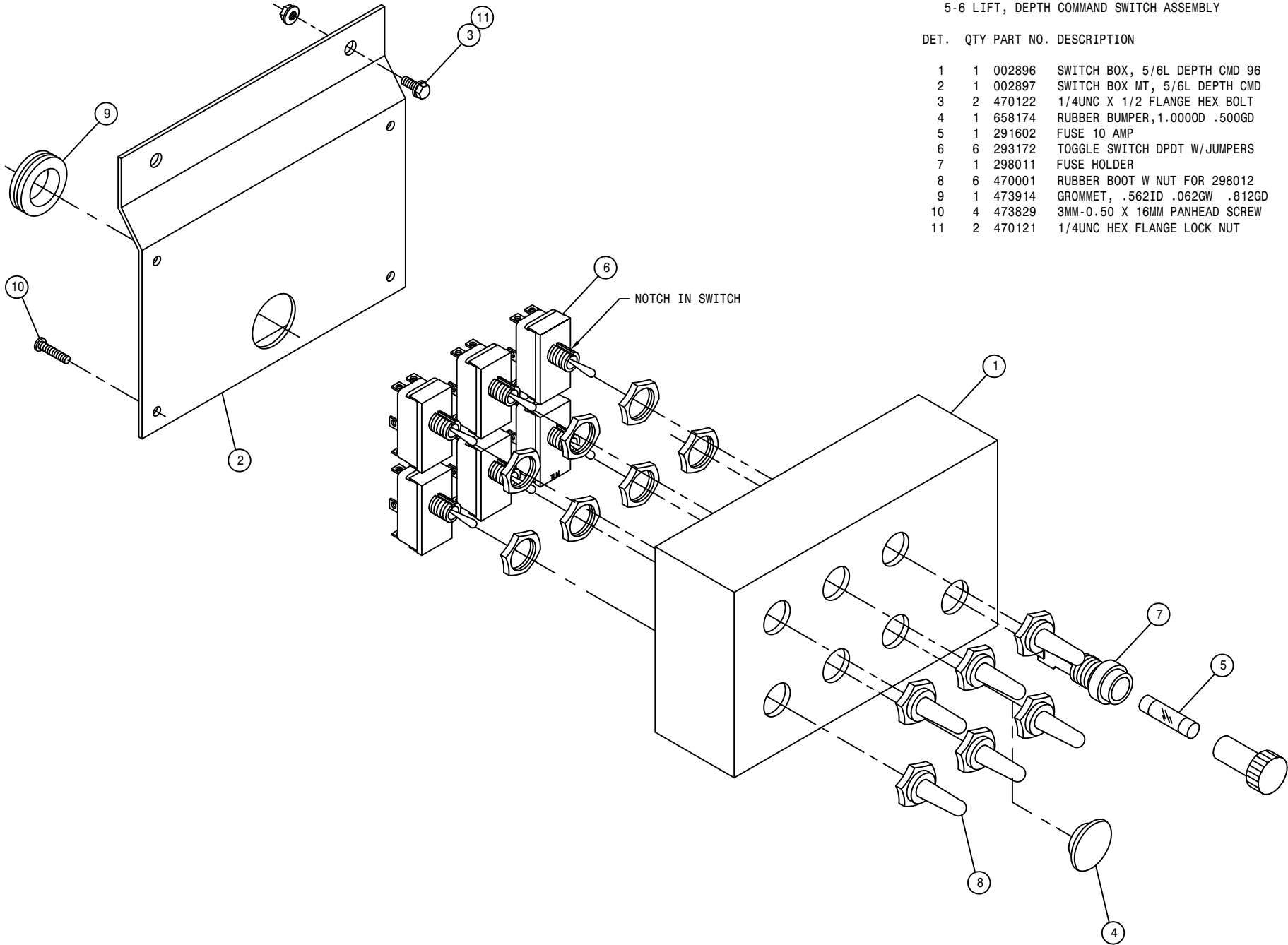

DEPTH COMMAND ACTUATOR ASSEMBLY

DET. QTY PART NO. DESCRIPTION

1	1	002849	HD DEPTH CMD ARM MT WLD	94
2	1	002846	HD DEPTH CMD MTG BRKT WLD	94
3	1	002851	HD DEPTH CMD UPR ARM WLD	94
4	2	002855	HD DEPTH CMD LWR ARM WLD	94
5	2	002858	HD DEPTH CMD ARM BUSH	94
6	1	291634	LINEAR ACTUATOR, KODIAK K2	
7	2	473949	5/16UNC-1 9/16ID-1 15/16U-BOLT	
8	1	900267	1/2UNC X 2" HEX BOLT	
9	1	900069	5/16UNC X 2" HEX BOLT	
10	1	900070	5/16UNC X 2 1/2 BOLT	
11	2	900263	1/2UNC X 1" HEX BOLT	
12	2	914008	1/2UNC HEX STOVER NUT	
13	6	914002	5/16UNC HEX STOVER NUT	
14	2	920004	1/2 SAE FLAT WASHER	
15	1	900275	1/2UNC X 4 1/2 HEX BOLT	

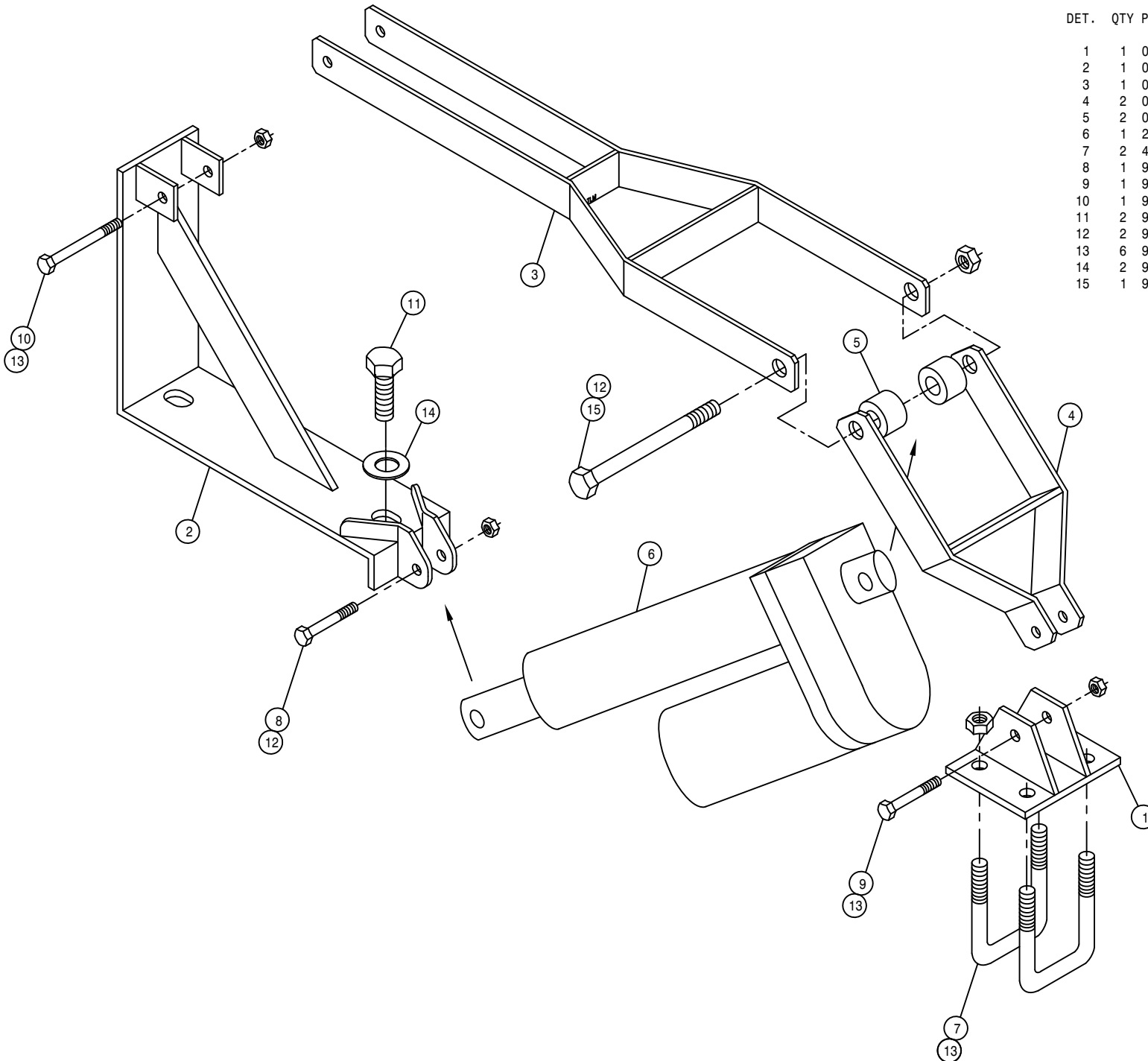

74

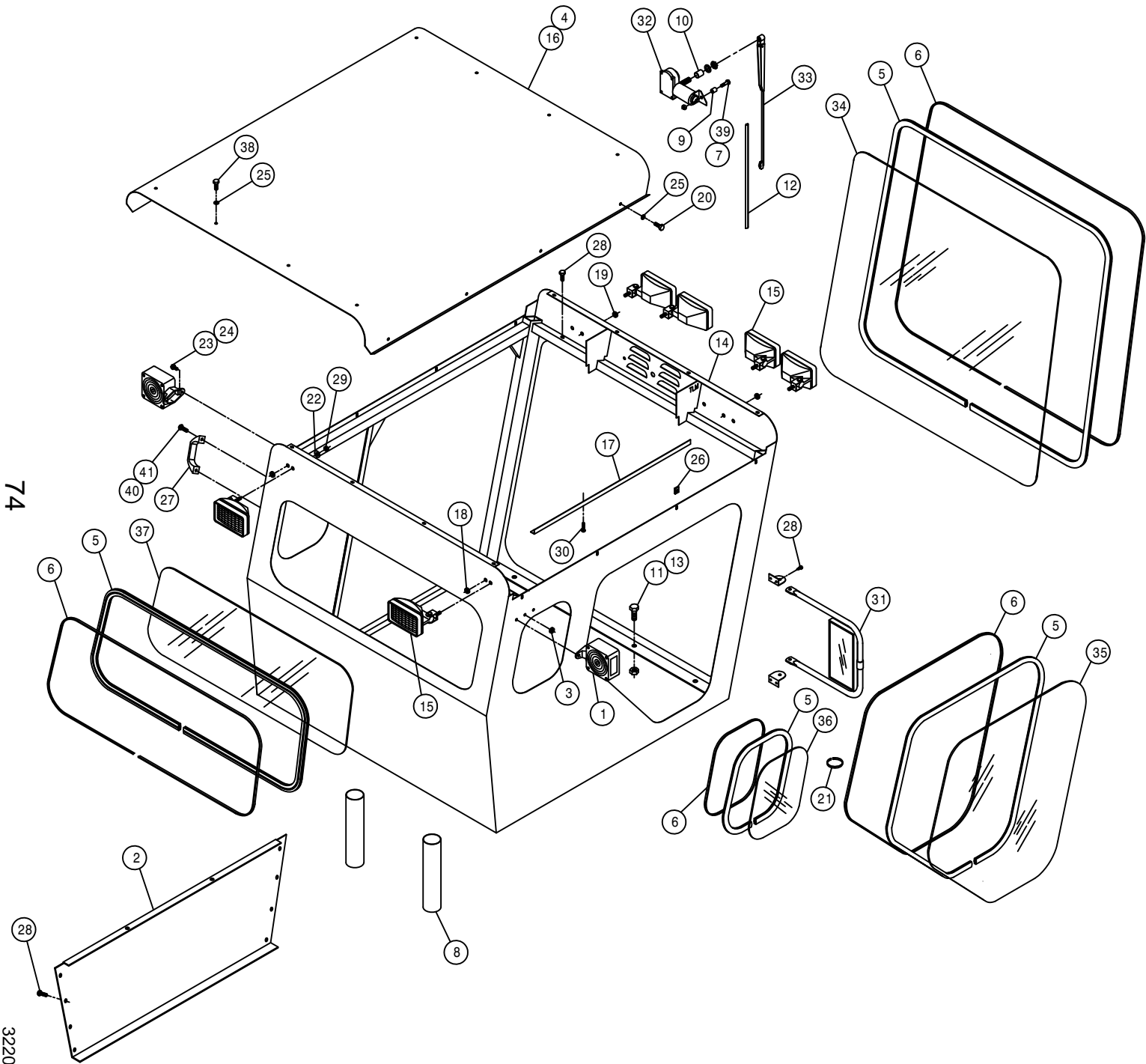

CAB ASSEMBLY

DET.	QTY	PART NO.	DESCRIPTION
1	2	291604	TURN SIGNAL LIGHT,PED MT, YEL
2	1	342295	LH SIDE PANEL, 204 CAB 95
3	2	470226	GROMMET, .156ID .062GW .250GD
4	18	193037	STICKERTITE 1/8 X 3/4
5	42	193044	WINDOW WEATHERSTRIP
6	42	193045	LOCK STRIP FOR 193044
7	1	914000	1/4UNC HEX STOVER NUT
8	2	342333	NYL HOSE SLEEVE,2.64ID X 12.00
9	1	200019	.25 SCH 40BP X 1.00 LG C/L
10	1	202037	WINDSHIELD WIPER SPACER
11	6	900264	1/2UNC X 1 1/4 HEX BOLT
12	1	290417	18" WIPER BLADE
13	6	914008	1/2UNC HEX STOVER NUT
14	1	342287	204 CAB WELDMT 95
15	6	291603	HALOGEN WORKLAMP, SIDE MT 12V
16	1	342150	CAB ROOF WLD, 284 94
17	1	342180	HEADLINER KPR ANGLE,284CAB 94
18	2	470067	GROMMET, .250ID .125GW .375GD
19	2	470070	GROMMET, .375ID .062GW .500GD
20	8	470118	1/4UNC X 3/4 FLANGE HEX BOLT
21	1	470229	IDENTIFICATION TIE, WHITE
22	6	470100	3/8 INT TOOTH LOCK WASHER
23	4	470121	1/4UNC HEX FLANGE LOCK NUT
24	4	470122	1/4UNC X 1/2 FLANGE HEX BOLT
25	16	470212	1/4 BONDED SEALING WASH, SS
26	16	470218	1/4UNC NUT J-TYPE CAGE CLIP
27	1	470222	GRAB HANDLE, BLACK MOULDED
28	22	472349	1/4 X 3/4 20THD-IN TEK TYPE
29	6	473779	10MM-1.50 HEX NUT
30	2	473910	1/4 X 1 1/2 PHIL HD SHT MTL S
31	2	650524	OUTSIDE MIRROR W/MTG BRKT
32	1	658008	WINDSHIELD WIPER MOTOR
33	1	658013	WIPER ARM
34	1	658018	FRONT CAB GLASS, 204 95
35	1	658015	FRONT SIDE CAB/DOOR GLASS 94
36	2	658016	REAR SIDE CAB GLASS 94
37	1	658017	REAR CAB GLASS 94
38	8	900002	1/4UNC X 3/4 HEX BOLT
39	1	900005	1/4UNC X 1 1/2 HEX BOLT
40	2	470175	10-32 HEX FLANGE LOCK NUT
41	2	903883	10-32 X 1/2 SLT RDHD MACH SCR

322074

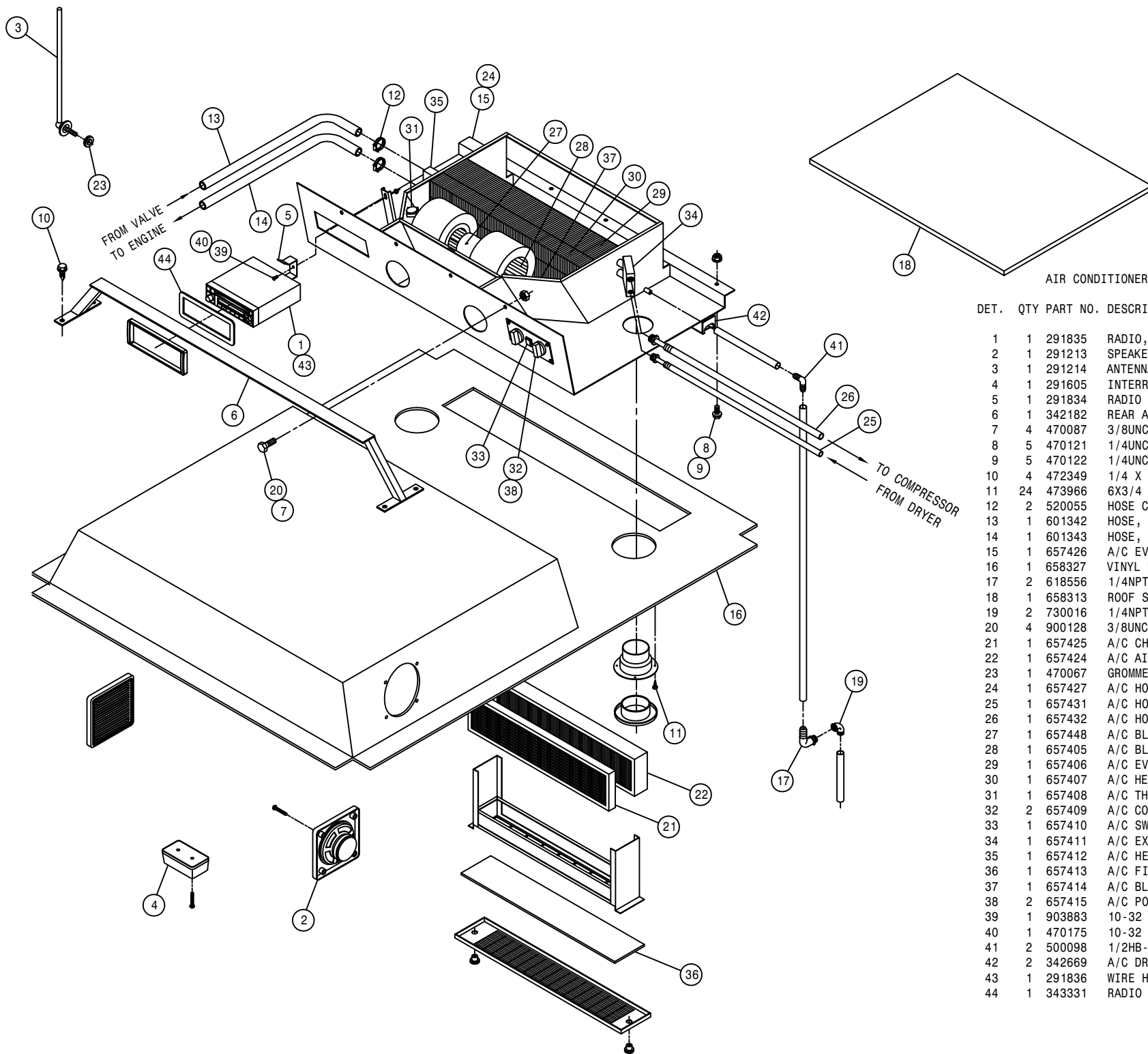

AIR CONDITIONER ASSEMBLY

DET. QTY PART NO. DESCRIPTION

1	1	291835	RADIO, AM/FM/CD/WB CRC-5320
2	1	291213	SPEAKERS (PAIR)
3	1	291214	ANTENNA
4	1	291605	INTERIOR LIGHT W/SWITCH
5	1	291834	RADIO SUPPORT BRKT
6	1	342182	REAR A/C BLOWER MT WLD,CAB 94
7	4	470087	3/8UNC HEX FLANGE LOCK NUT
8	5	470121	1/4UNC HEX FLANGE LOCK NUT
9	5	470122	1/4UNC X 1/2 FLANGE HEX BOLT
10	4	472349	1/4 X 3/4 20THD-IN TEK TYPE
11	24	473966	6X3/4 PHIL FLT HD SHT MTL SCR
12	2	520055	HOSE CLAMP NO 12 STAINLESS
13	1	601342	HOSE, 5/8 X 192 HEATER
14	1	601343	HOSE, 5/8 X 216 HEATER
15	1	657426	A/C EVAPORATOR/HEATER, 284
16	1	658327	VINYL HEAD LINER
17	99		
18	2	618556	1/4NPT-90-1/2 HOSE BARB,POLY
19	1	658313	ROOF SEAL,AIR COND 204,254,284
20	2	730016	1/4NPT ST EL, 90 DEG POLY
21	4	900128	3/8UNC X 3/4 HEX BOLT
22	1	657425	A/C CHARCOAL AIR FILTER
23	1	657424	A/C AIR FILTER
24	1	470067	GROMMET, .250ID .125GW .375GD
25	1	657427	A/C HOSE KIT, EVAP 284, 99
26	1	657431	A/C HOSE ASSY, 5/16 X 173
27	1	657432	A/C HOSE ASSY, 1/2 X 190.
28	1	657448	A/C BLOWER ASSY, 12V KENWAY
29	1	657405	A/C BLOWER WHEEL W/CLIP
30	1	657406	A/C EVAPORATOR COIL
31	1	657407	A/C HEATER COIL
32	1	657408	A/C THERMOSTAT
33	2	657409	A/C CONTROL KNOB
34	1	657410	A/C SWITCH, PUSH ON-OFF
35	1	657411	A/C EXPANSION VALVE
36	1	657412	A/C HEATER VALVE,4-WAY MTRIZED
37	1	657413	A/C FILTER, RECIRCULATION
38	1	657414	A/C BLOWER DRIVE ASSY
39	2	657415	A/C POTENTIOMETER ASSY
40	1	903883	10-32 X 1/2 SLT RDHD MACH SCR
41	1	470175	10-32 HEX FLANGE LOCK NUT
42	1	500098	1/2HB-90-1/2 HOSE BARB, POLY
43	2	342669	A/C DRAIN HOSE KEEPER
44	1	291836	WIRE HARNESS FOR 291835 RADIO
45	1	343331	RADIO BEZEL,CAB, BLK PLASIC 05

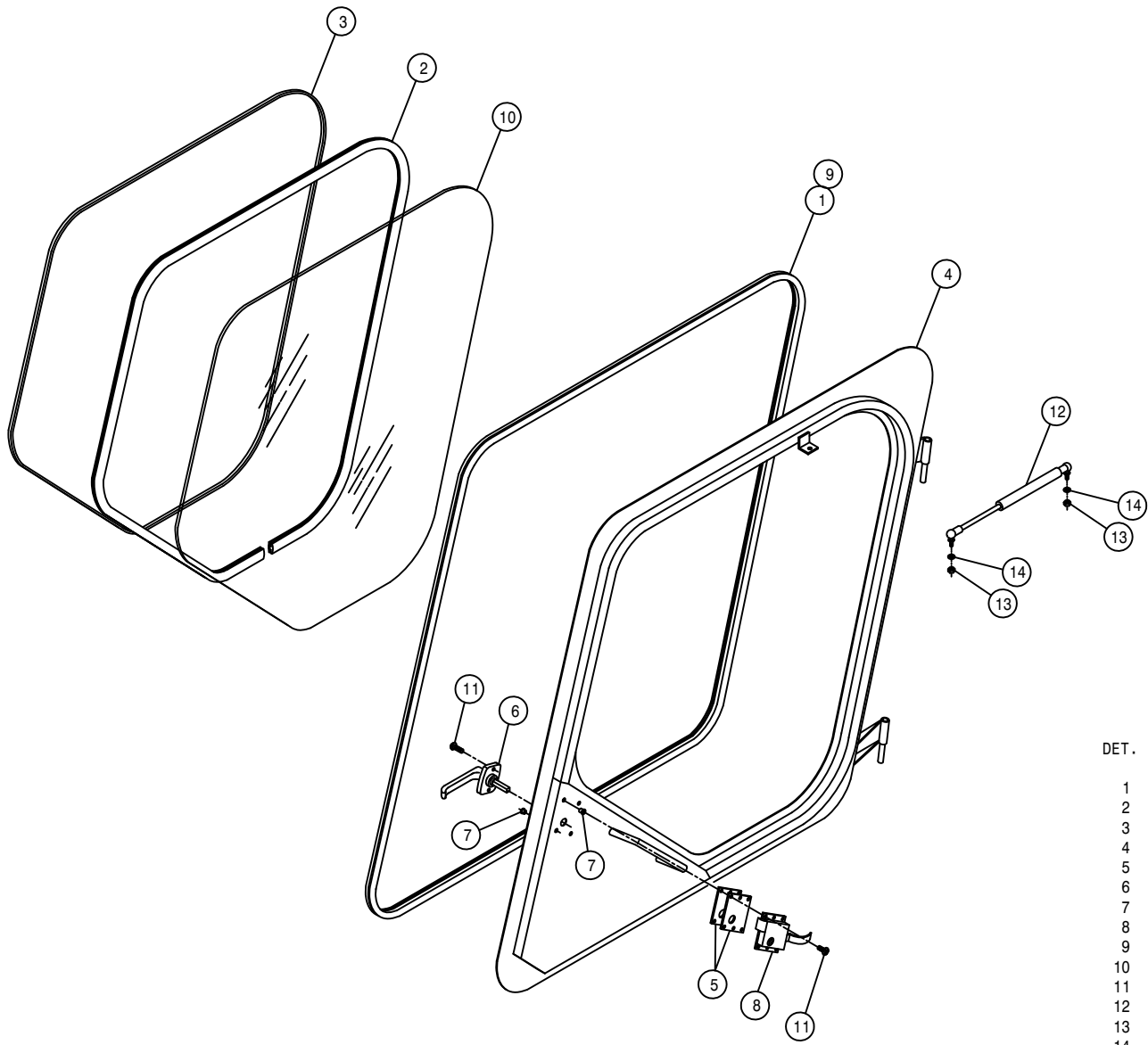

DOOR ASSEMBLY

DET. QTY PART NO. DESCRIPTION

1	12	193028	PUSH-ON TRIM SEAL RS-130-FX	
2	9	193044	WINDOW WEATHERSTRIP	
3	9	193045	LOCK STRIP FOR 193044	
4	1	342153	LH DOOR WLD, 284 CAB	94
5	2	342163	CAB DOOR LATCH SHIM, .06	94
6	1	342217	DOOR HANDLE, 254/284 CAB	94
7	6	470165	10-32 NUTSERT .020-.100 MATL	
8	1	470219	CAB LOCK, LH #55	
9	2	485052	POP RIVET 1/8 X 3/8	
10	1	658015	FRONT SIDE CAB/DOOR GLASS	94
11	6	903710	10-32X5/8 PHIL PANHD MACH SCR	
12	1	470221	GAS SPRING, 60LB 3.5 STROKE	
13	2	910002	5/16UNC HEX NUT	
14	2	920501	5/16 LOCK WASHER	

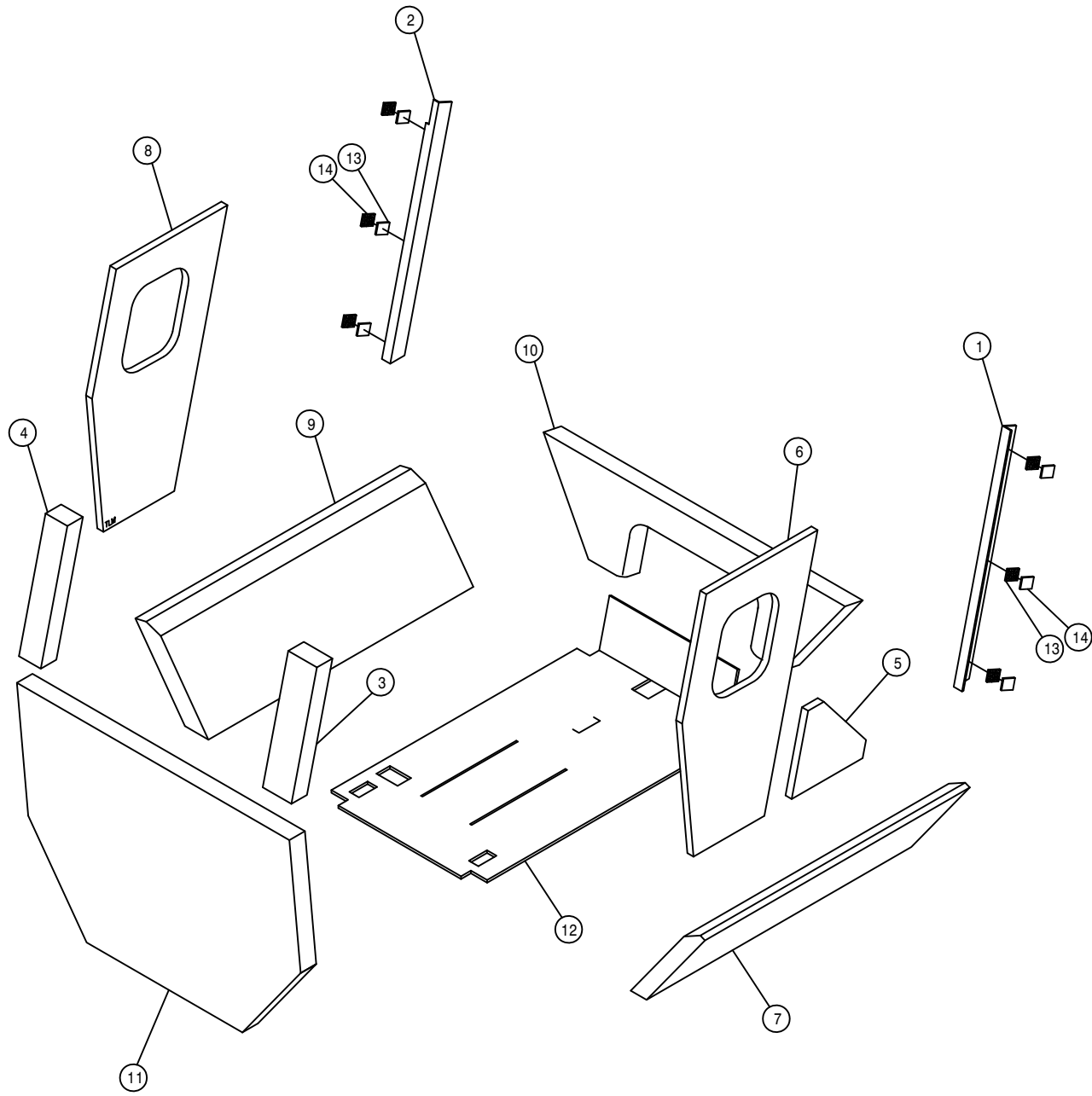

CAB FOAM

DET. QTY PART NO. DESCRIPTION

1	1	658301	VINYL POST COVER, RH FRONT	94
2	1	658302	VINYL POST COVER, LH FRONT	94
3	1	658303	VINYL POST COVER, RH REAR	94
4	1	658304	VINYL POST COVER, LH REAR	94
5	1	658305	VINYL SIDE PANEL, RH	94
6	1	658306	VINYL SIDE PANEL, RH UPPER	94
7	1	658307	VINYL SIDE PANEL, RH LOWER	94
8	1	658308	VINYL SIDE PANEL, LH UPPER	94
9	1	658309	VINYL SIDE PANEL, LH LOWER	94
10	1	658310	VINYL FRONT COVER PANEL	94
11	1	658311	VINYL REAR COVER PANEL	94
12	1	658315	CAB FLOORMAT 254/284	95
13	6	471101	DUAL LOCK, 1.00 X 1.00	SJ3542
14	6	471100	DUAL LOCK, 1.00 X 1.00	SJ3541

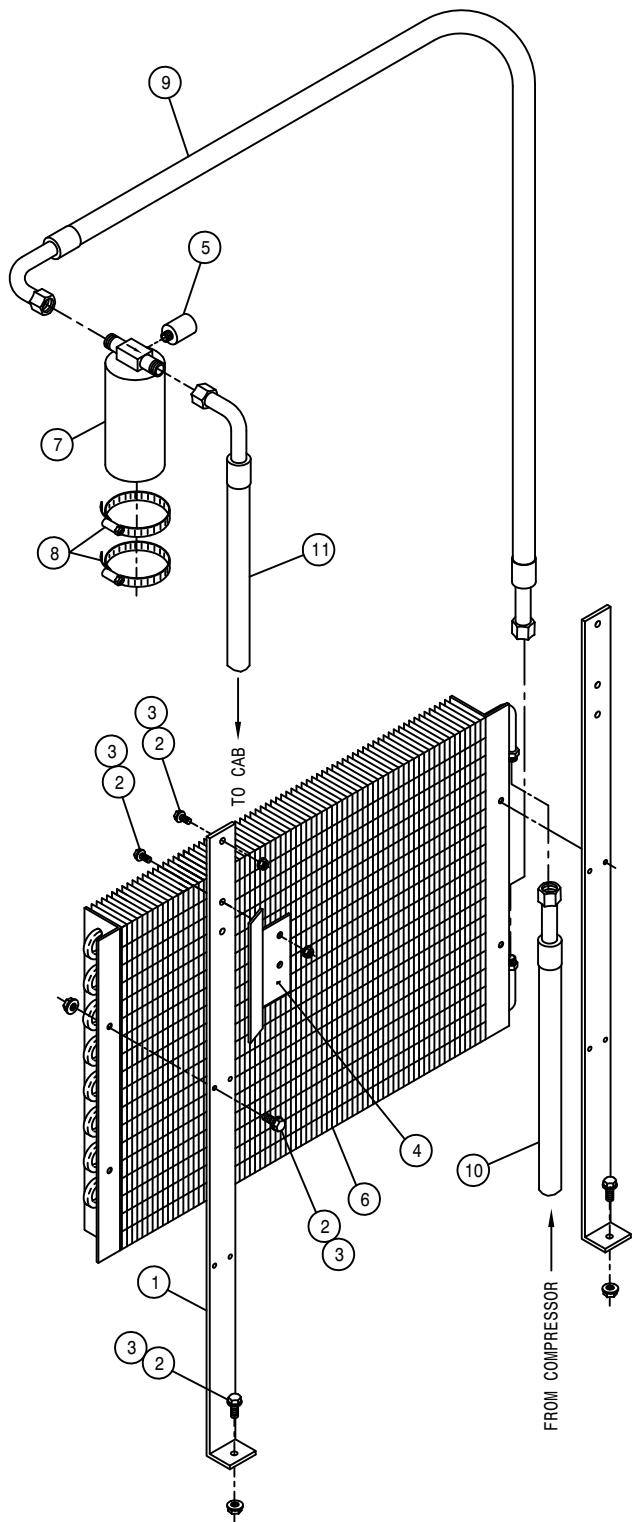

A/C CONDENSOR ASSEMBLY

DET.	QTY	PART NO.	DESCRIPTION	
	2	315036	CONDENSER MTG BRKT	99
	10	470118	1/4UNC X 3/4 FLANGE HEX BOLT	
	10	470121	1/4UNC HEX FLANGE LOCK NUT	
	1	315038	A/C DRIER MT,204-254-284	99
	1	657422	A/C BINARY SWITCH	
	1	657423	A/C CONDENSER COIL 21-0324	
	1	657421	A/C RECEIVER/DRIER	
	2	520052	HOSE CLAMP NO 52 STAINLESS	
	1	657429	A/C HOSE ASSY, 5/16 X 44	
	1	657430	A/C HOSE ASSY, 13/32 X 80	
	1	657431	A/C HOSE ASSY, 5/16 X 173	

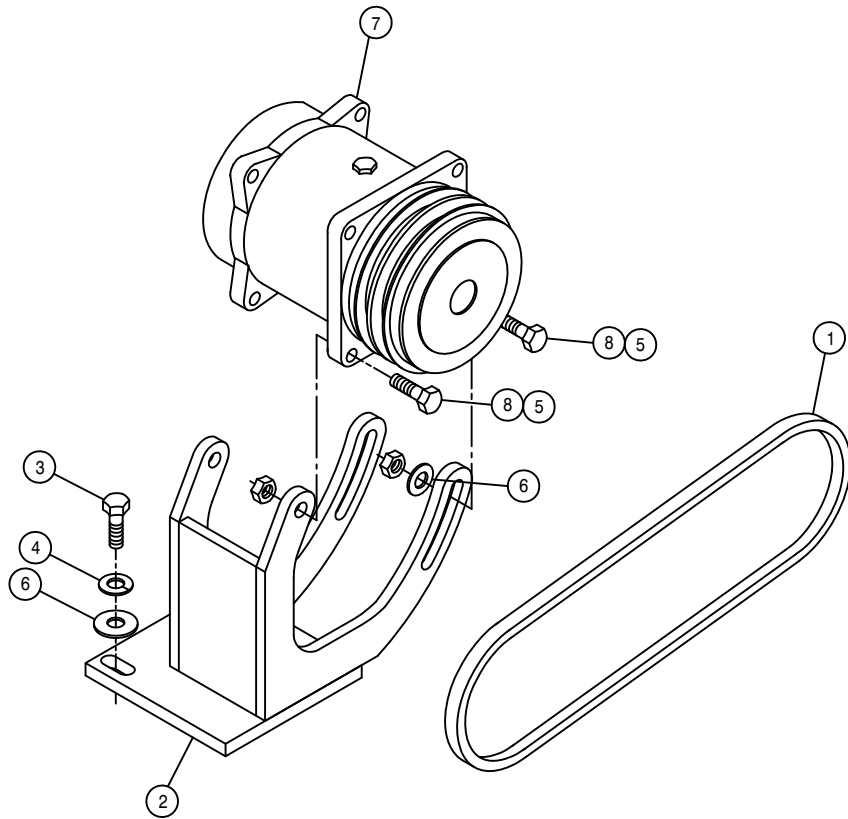

A/C COMPRESSOR PUMP ASSEMBLY

DET. QTY PART NO. DESCRIPTION

1	1	147050	9455XL BELT, GATES	
2	1	316314	A/C COMPRSR MT WLD, 284	98
3	3	473792	10MM-1.50 X 30MM HEX BOLT	
4	3	473798	10MM LOCK WASHER	
5	4	914004	3/8UNC HEX STOVER NUT	
6	5	483043	3/8 REGULAR FLAT WASHER	
7	1	657403	A/C COMPR, 180D PORTS TM15/12	
8	4	900131	3/8UNC X 1 1/2 HEX BOLT	

CANOPY ASSEMBLY

DET. QTY PART NO. DESCRIPTION

1	1	342151	CAB ROOF, 284	94
2	1	342270	CANOPY WLD, 204	94
3	1	658314	CANOPY ROOF FOAM, 204	94
4	20	470122	1/4UNC X 1/2 FLANGE HEX BOLT	
5	20	470121	1/4UNC HEX FLANGE LOCK NUT	
6	16	470212	1/4 BONDED SEALING WASH, SS	
7	2	291604	TURN SIGNAL LIGHT,PED MT, YEL	
8	6	291603	HALOGEN WORKLAMP,SIDE MT 12V	
9	4	472349	1/4 X 3/4 20THD-IN TEK TYPE	
10	2	470067	GROMMET, .250ID .125GW .375GD	
11	2	470070	GROMMET, .375ID .062GW .500GD	
12	2	470226	GROMMET, .156ID .062GW .250GD	
13	6	470100	3/8 INT TOOTH LOCK WASHER	
14	6	473779	10MM-1.50 HEX NUT	
15	6	900264	1/2UNC X 1 1/4 HEX BOLT	
16	6	914008	1/2UNC HEX STOVER NUT	
17	6	520117	CUSH HOSE CLAMP 5/8D X 1/2W	

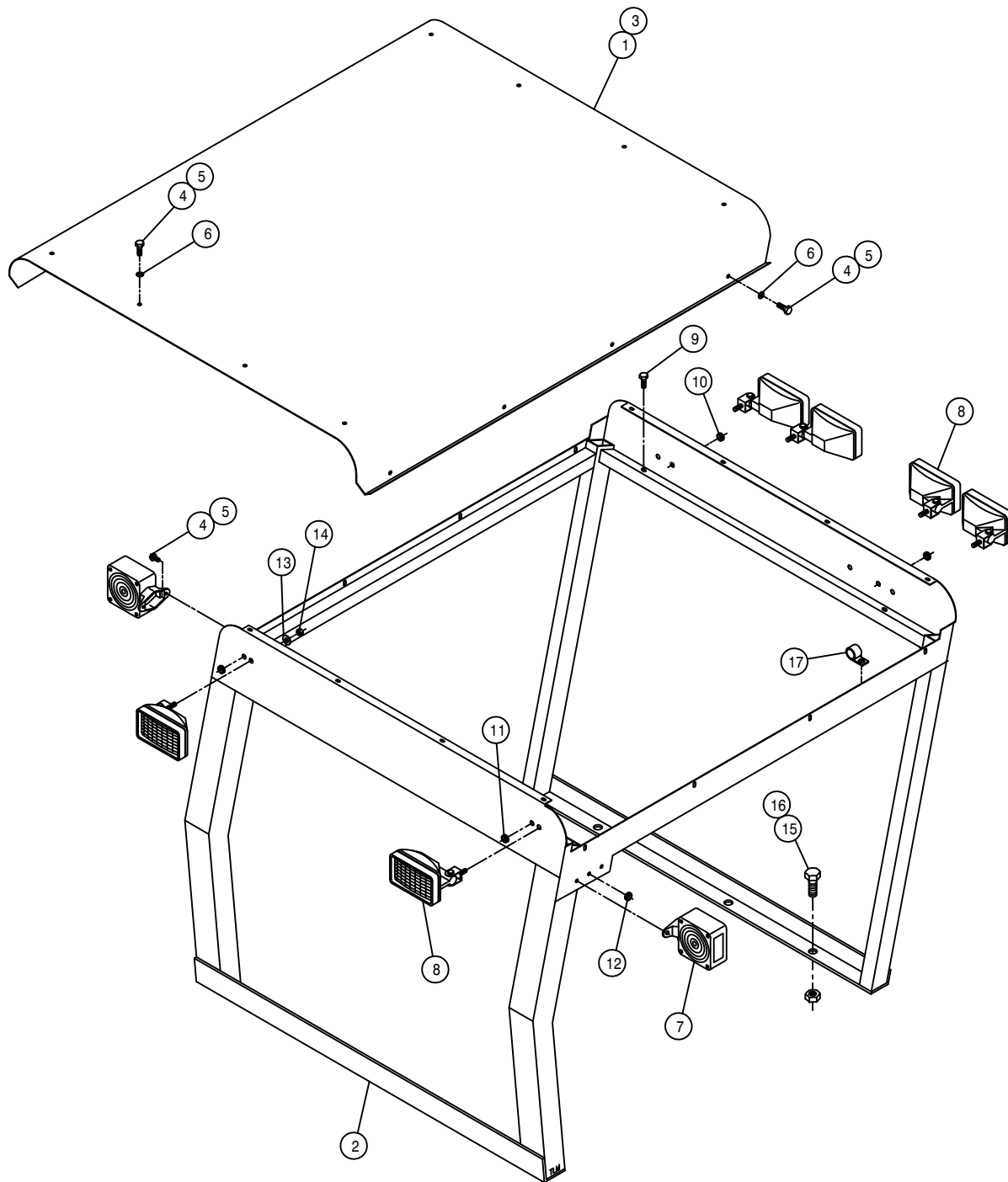

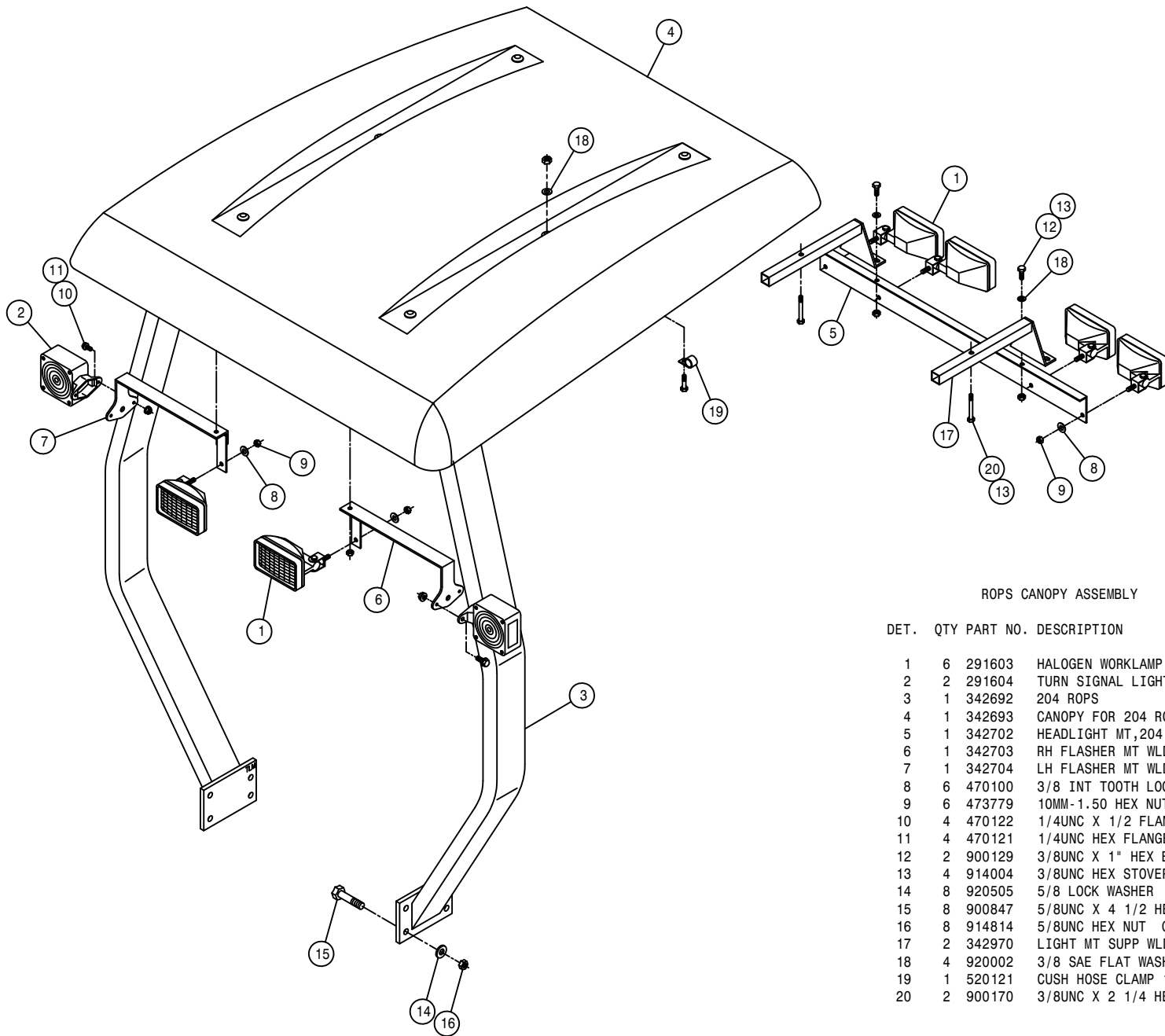

ROPS CANOPY ASSEMBLY

DET.	QTY	PART NO.	DESCRIPTION
1	6	291603	HALOGEN WORKLAMP, SIDE MT 12V
2	2	291604	TURN SIGNAL LIGHT, PED MT, YEL
3	1	342692	204 ROPS
4	1	342693	CANOPY FOR 204 ROPS (342692)
5	1	342702	HEADLIGHT MT, 204 ROPS 2000
6	1	342703	RH FLASHER MT WLD, 204 ROPS 2000
7	1	342704	LH FLASHER MT WLD, 204 ROPS 2000
8	6	470100	3/8 INT TOOTH LOCK WASHER
9	6	473779	10MM-1.50 HEX NUT
10	4	470122	1/4UNC X 1/2 FLANGE HEX BOLT
11	4	470121	1/4UNC HEX FLANGE LOCK NUT
12	2	900129	3/8UNC X 1" HEX BOLT
13	4	914004	3/8UNC HEX STOVER NUT
14	8	920505	5/8 LOCK WASHER
15	8	900847	5/8UNC X 4 1/2 HEX BOLT GR8
16	8	914814	5/8UNC HEX NUT GR8
17	2	342970	LIGHT MT SUPP WLD, 204 ROPS 04
18	4	920002	3/8 SAE FLAT WASHER
19	1	520121	CUSH HOSE CLAMP 1IN X 3/4W
20	2	900170	3/8UNC X 2 1/4 HEX BOLT

REAR WEIGHT BRACKET ASSEMBLY

DET. QTY PART NO. DESCRIPTION

1	1	341980	RH REAR TOOL BAR MT WLD 2XX
2	1	341981	LH REAR TOOL BAR MT WLD 2XX
3	1	438575	RH WEIGHT MT BRKT WLD 96
4	1	438576	LH WEIGHT MT BRKT WLD 96
5	1	438660	IH 173MAG WEIGHT ADPT PLT WLD
6	1	438581	WEIGHT MT PLATE WLD,JD 204 96
7	4	900277	1/2UNC X 5 1/2 HEX BOLT
8	4	900281	1/2UNC X 7 1/2 HEX BOLT
9	4	900335	5/8UNC X 2" HEX BOLT
10	8	914008	1/2UNC HEX STOVER NUT
11	4	914010	5/8UNC HEX STOVER NUT
12	8	920004	1/2 SAE FLAT WASHER

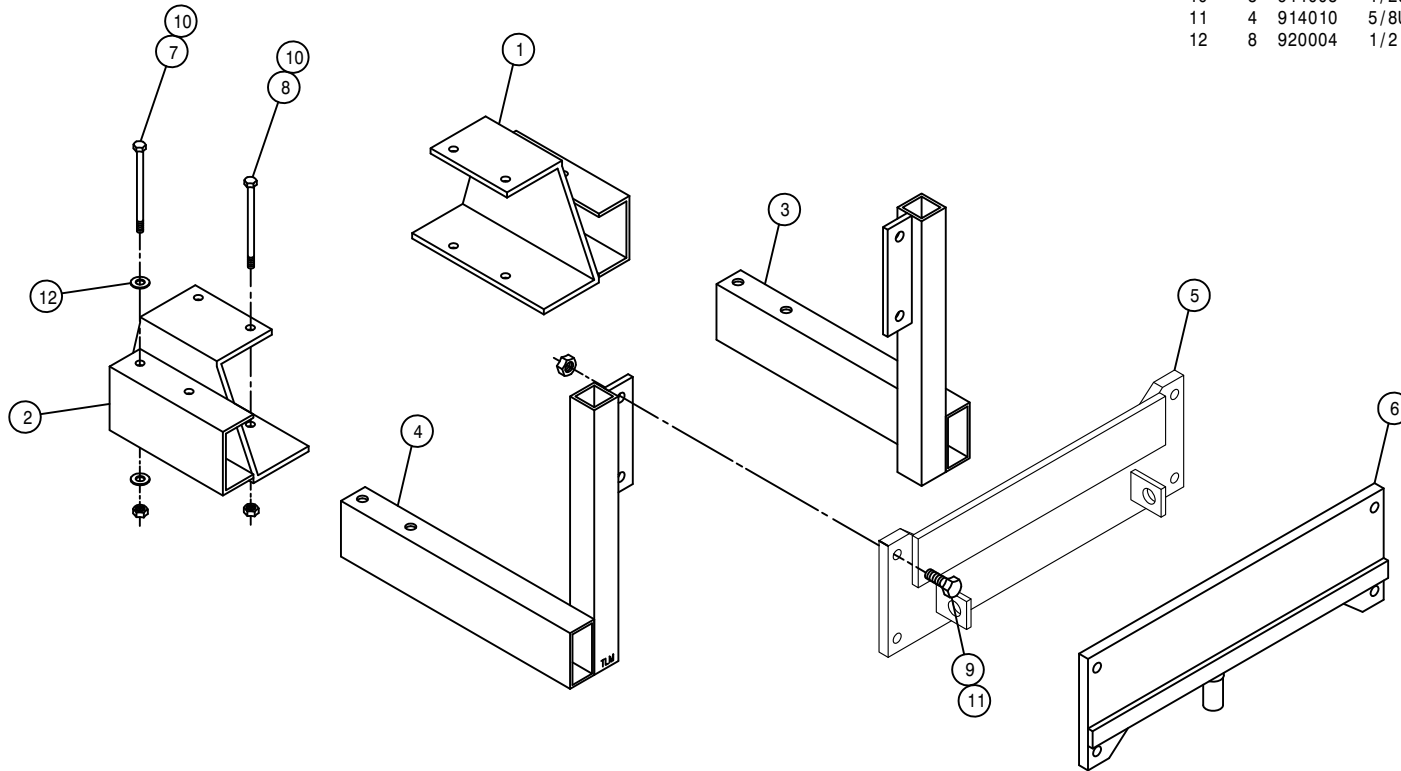

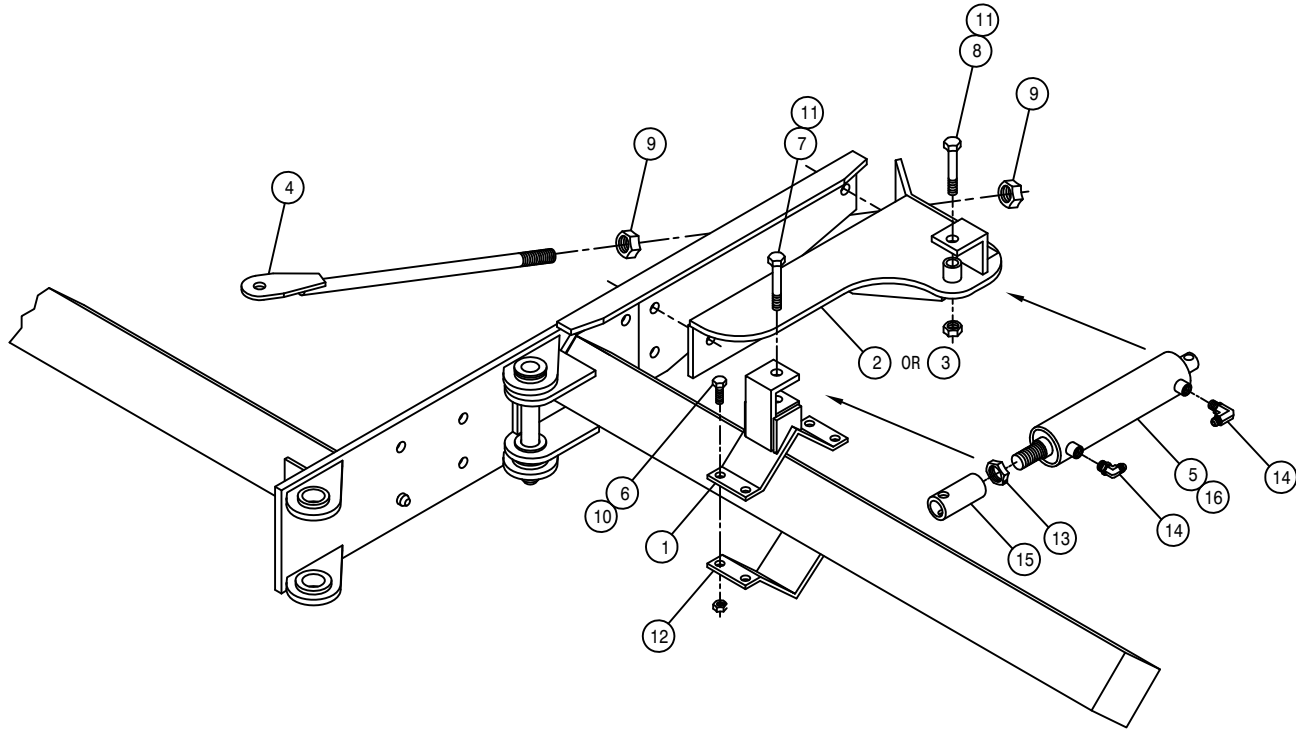

OUTRIGGER HYDRAULIC FOLD ASSEMBLY

DET.	QTY	PART NO.	DESCRIPTION
1	2	438747	OUTRGR CYL MT WLD, 204SP
2	1	438735	RH FOLD CYL MT WLD, 204/SP
3	1	438736	LH FOLD CYL MT WLD, 204/SP
4	2	438745	FOLD CYL MT SUPP ROD WLD204/SP
5	2	621520	BOOM HINGE FOLD CYL ASSY
6	8	900265	1/2UNC X 1 1/2 HEX BOLT
7	2	900338	5/8UNC X 3" HEX BOLT
8	2	900341	5/8UNC X 3 3/4 HEX BOLT
9	4	910012	3/4UNC HEX NUT
10	8	914008	1/2UNC HEX STOVER NUT
11	4	914010	5/8UNC HEX STOVER NUT
12	2	438324	75IN OUTRGR BRACE CLAMP
13	2	472322	7/8-14 UNF HEX JAM NUT
14	4	614747	.025 ELBOW ASSY,9/16MOR 90D
15	2	620653	FOLD CYL ADJ SLEEVE
16	2	621521	REPAIR KIT, HYD CYL 621520

QUANTITY LISTED IS FOR ONE MACHINE.

97

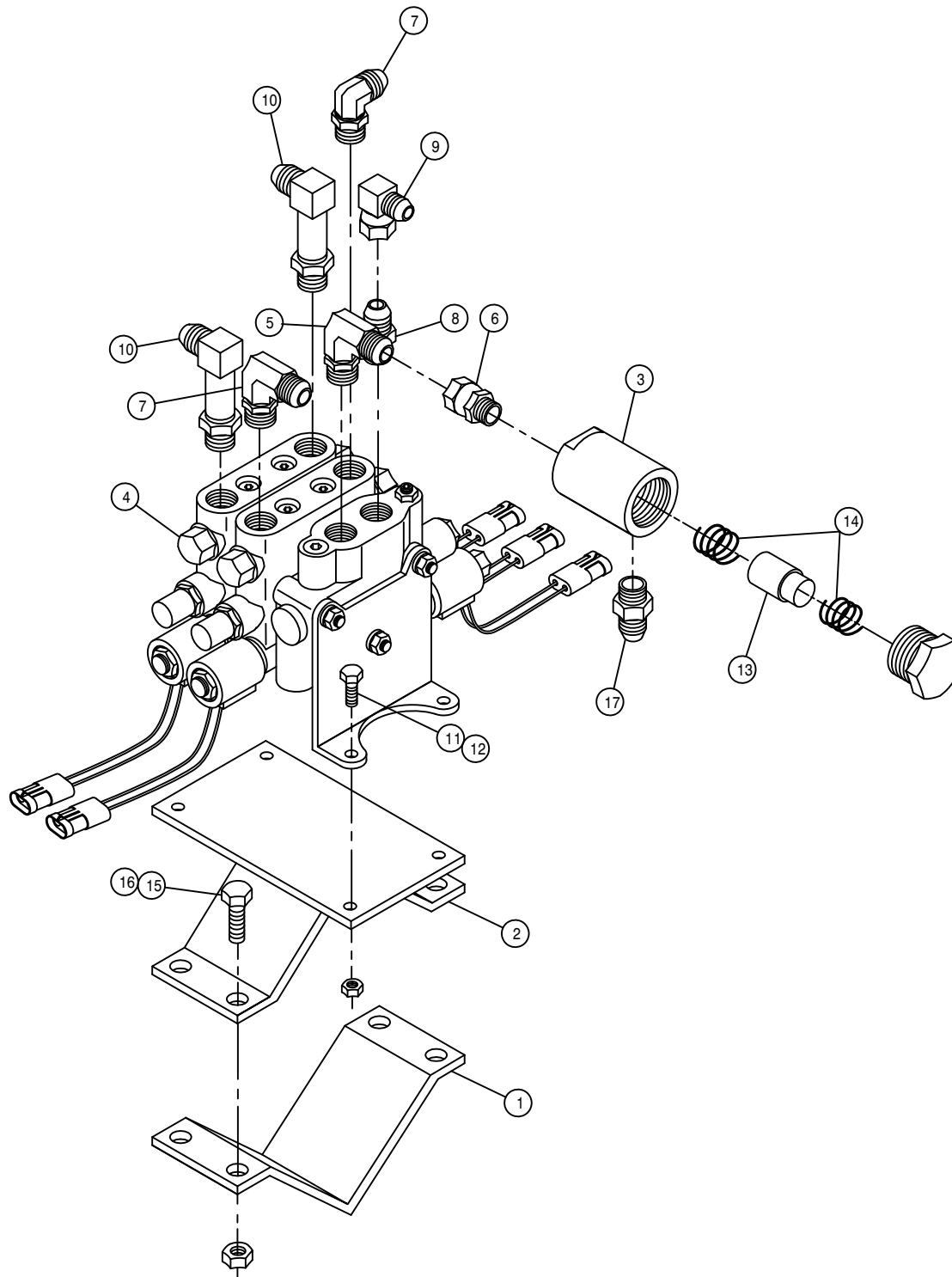

OUTRIGGER FOLD VALVE ASSEMBLY

DET. QTY PART NO. DESCRIPTION

1	1	438324	75IN OUTRGR BRACE CLAMP
2	1	438724	OUTRGR FOLD VLV MT WLD2100/STS
3	1	605615	HYD FILTER, INLINE 25M 9/16FOR
4	1	606090	BRAND HYD VALVE, 2-SECT SER 36
5	1	618183	3/4MJIC-90-7/8MOR LBO
6	1	618692	3/4FJIC SWIV-9/16MOR ADPTR
7	2	618115	9/16MJIC-90-3/4MOR LBO
8	1	618310	9/16MJIC-7/8MOR ADPTR
9	1	618618	9/16MJIC-90-9/16FJIC SWIV LBO
10	2	618709	9/16MJIC-90-3/4MOR EX LG LBO
11	4	900065	5/16UNC X 1" HEX BOLT
12	4	914002	5/16UNC HEX STOVER NUT
13	1	605616	ELEMENT, 25M HYD FILTER 605615
14	1	605617	SPRING KIT, HYD FILTER 605615
15	4	900265	1/2UNC X 1 1/2 HEX BOLT
16	4	914008	1/2UNC HEX STOVER NUT
17	1	618126	9/16MJIC-9/16MOR ADPTR

This Page Intentionally Blank

NOTICE

The following page contains decals for the model 204 SP.

These decals can be obtained from Hagie Mfg. Co. and should be used whenever your machine is repainted or when the decals become worn, weathered, or faded.

Special attention should be paid to decals involving personal safety. They have been attached for your protection.

KEEP THEM IN PLACE.

Contact: Hagie Manufacturing Co.
Box 273
Clarion, Iowa 50525

204SP DECALS

QTY.	PART NO.	DESCRIPTION	LOCATION
1	650831	EMERGENCY STOP DECAL	ON CONSOLE SHEET METAL
1	650329	TRACTION VALVE DECAL	ON INSTRUMENT PANEL
1	650154	PATENTS,HAGIE UPFRONT DECAL	ON LOWER LEFT REAR OF MAINFRAME
1	650303	CUTTER ROTATION DECAL	ON FRONT OPERATOR STATION
2	650819	DANGER, CUTTING BLADES	2-ON EACH CUTTER HEAD
1	650847	NO PASSENGER DECAL	ON FRONT OPERATOR STATION
2	650848	SLIP OR FALL DECAL	NEXT TO STEP ON EACH LEG RAIL
2	650849	ENGINE FUEL DECAL	NEAR EACH FUEL TANK NECK
4	650985	WHEEL BOLT TORQUE DECAL	ON EACH WHEEL RIM
2	650851	SHIELDS DECAL	ON SIDE OF TOP ENGINE COVER
1	650852	READ MANUAL DECAL	ON FRONT OPERATOR STATION
1	650981	COOLING SYSTEM DECAL	NEAR RADIATOR CAP
1	650982	ELECTRICAL DECAL	RIGHT HAND SIDE OF OIL TANK
3	650931	HAGIE DECAL 1 3/4 X 4	1 - ON EACH TASSEL DEFLECTOR 1 - ON EACH QUAD PULLER
4	650820	CAUTION MOVING PARTS DECAL	2 - EACH TASSEL DEFLECTOR 1 - ON EACH QUAD PULLER 1 - ON EACH TIRE PULLER
2	650954	DIESEL DECAL	NEAR EACH FUEL TANK NECK
1	KDC001	204SP DECAL KIT	ON EACH ENGINE HOOD
1	650340	PARK BRAKE DECAL	ON CONSOLE SHEET METAL
1	650308	LEFT L-CTR R-CTR RIGHT DECAL	DEPTH COMMAND SWITCH BOX
1	650368	CONSOLE COVER DECAL	ON CONSOLE COVER
1	650347	NOTICE-R134A CHARGE DECAL	NEXT TO A/C COMPRESSOR
1	650339	WARNING, HYD OIL INJ DECAL	ON FRONT OPERATOR STATION
1	650338	DEPTH CMD 6-LIFT DECAL	DEPTH COMMAND SWITCH BOX
1	650320	EMERGENCY EXIT DECAL	RIGHT SIDE CAB GALSS
4	650364	AIR BAG WARNING DECAL	1-EACH LEG TOWER NEAR VALVE STEM
1	650367	AIR FILTER INSTRUCTION DECAL	ON ENGINE AIR FILTER END CAP

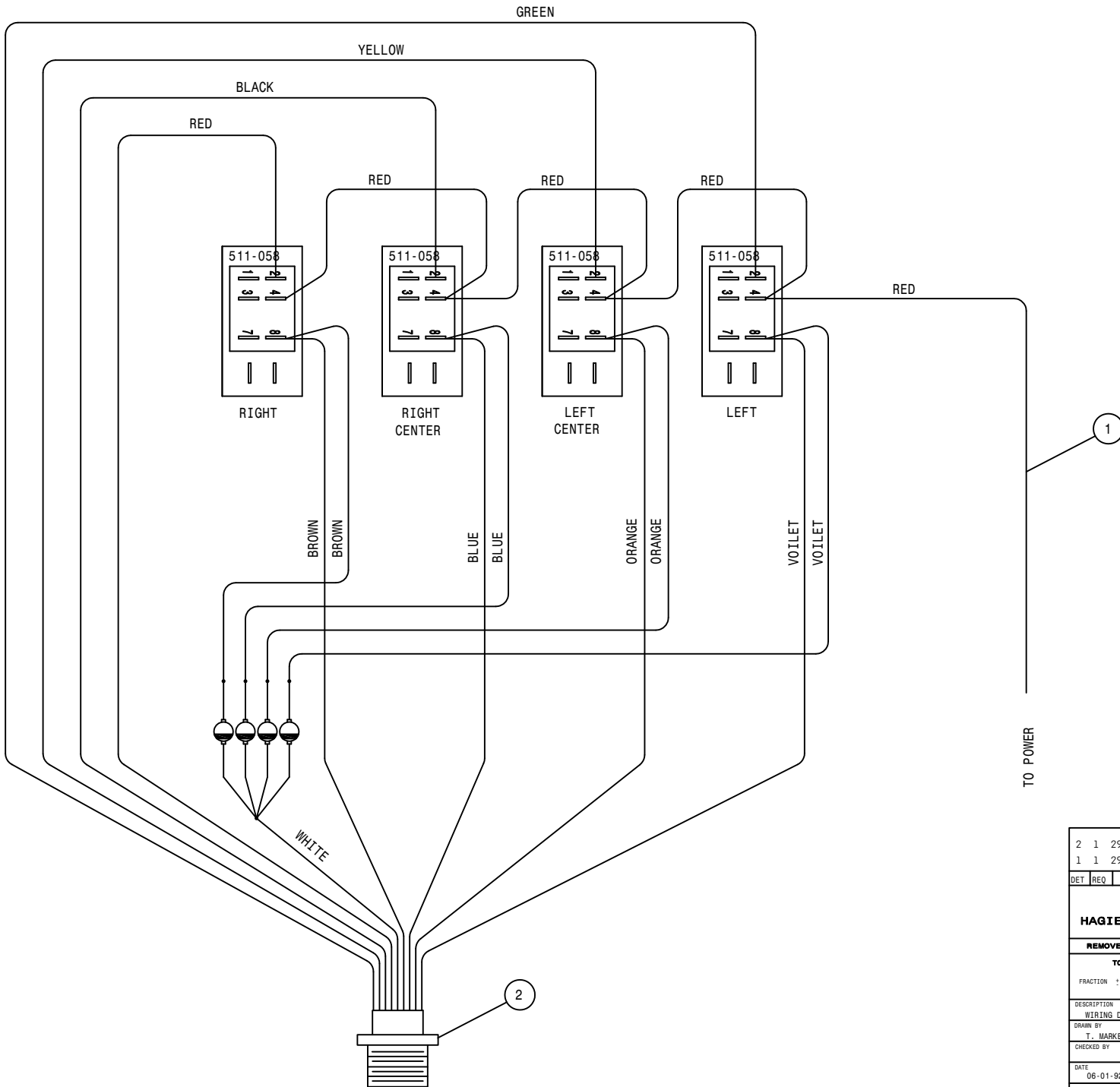

2	1	293248	MANUAL LS SYS SW HARNESS
1	1	293249	MANUAL LS SYS PWR WIRE ASSY
DET	REQ	DESCRIPTION	
HAGIE			
HAGIE MANUFACTURING COMPANY			
CLARION, IOWA 50525			
REMOVE ALL SHARP CORNERS & BURRS			
TOLERANCE UNLESS OTHERWISE SPECIFIED			
FRACTION	1/32	DECIMALS	X.XX 1.00 X.XXX 1.005
ANGLES	1°		
DESCRIPTION			
WIRING DIAG. MANUAL LS SYS SW			
DRAWN BY	T. MARKER		SCALE
		NONE (1)	
CHECKED BY			APPROVED BY
DATE	06-01-92	DRAWING NUMBER	498414
SHEET	OF		

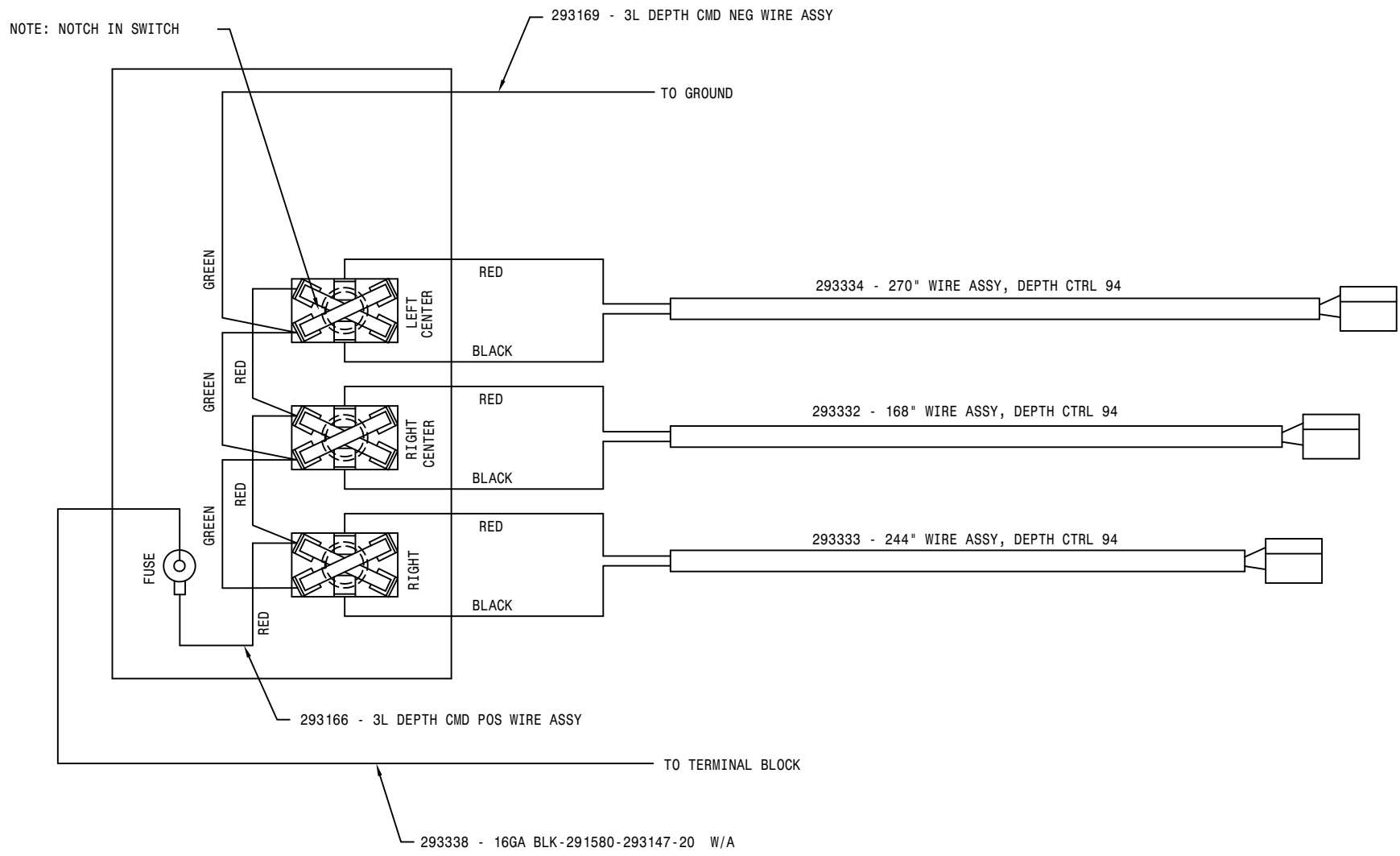

DET	REQ	DESCRIPTION			
HAGIE HAGIE MANUFACTURING COMPANY <small>CLARION, IOWA 50525</small>					
REMOVE ALL SHARP CORNERS & BURRS					
TOLERANCE UNLESS OTHERWISE SPECIFIED					
FRACTION	± 1/32	DECIMALS	X.XX ±.03 X.XXX ±.005	ANGLES	± *
DESCRIPTION					
WIRE DIAG, 3-LIFT DEPTH CMD 94					
DRAWN BY		SCALE			
T. MARKER		NONE			
CHECKED BY		APPROVED BY			
DATE		DRAWING NUMBER			
03-29-94		498451			
SHEET OF					

NOTE: NOTCH IN SWITCH

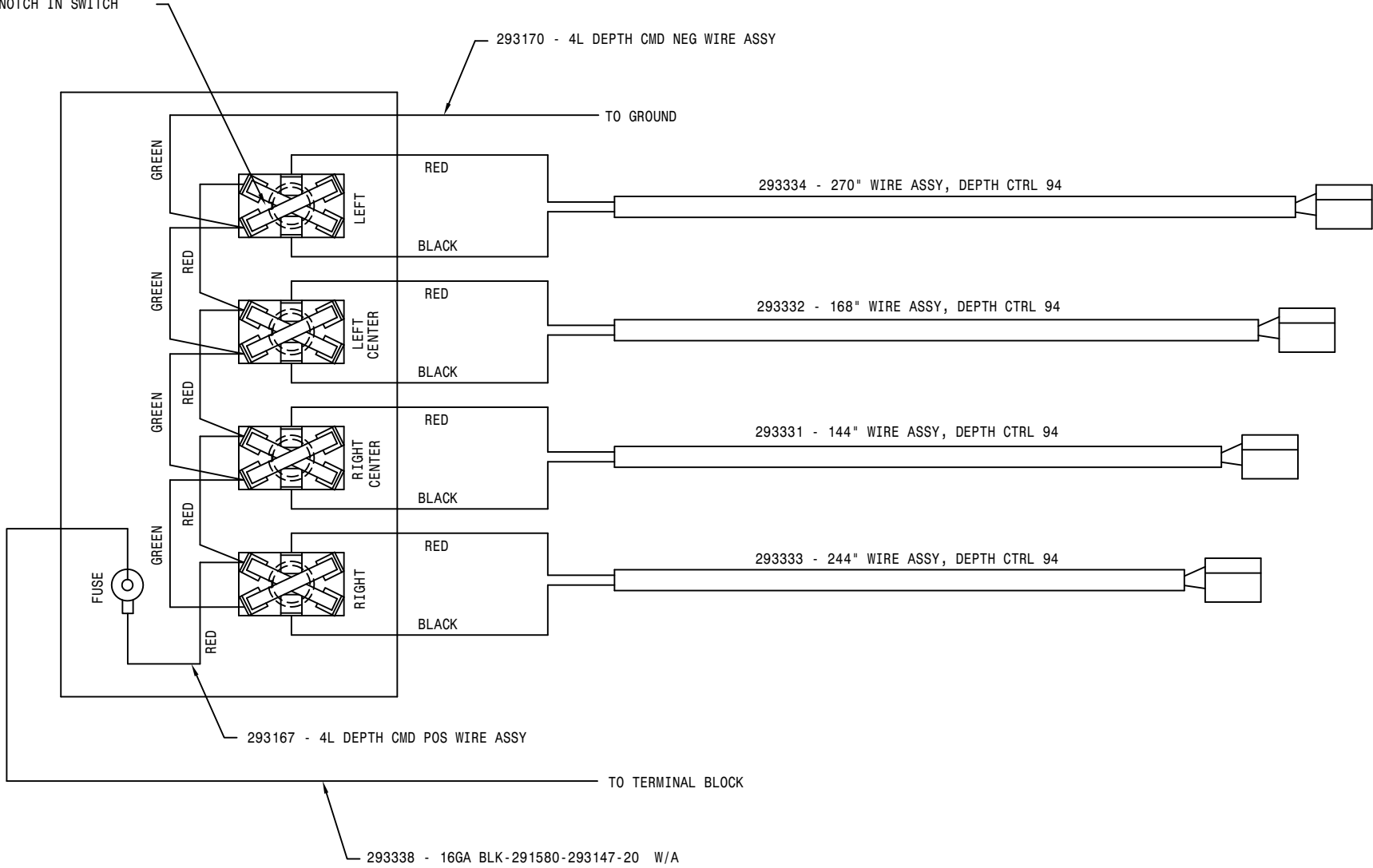

DET	REQ	DESCRIPTION		
HAGIE HAGIE MANUFACTURING COMPANY <small>CLARION, IOWA 50525</small>				
REMOVE ALL SHARP CORNERS & BURRS TOLERANCE UNLESS OTHERWISE SPECIFIED				
FRACTION	1/32	DECIMALS	X.XX X.XXX	°03 °005
ANGLES	1°			
DESCRIPTION				
WIRE DIAG, 4-LFT DEPTH CMD 94				
DRAWN BY	T. MARKER		SCALE	NONE
CHECKED BY			APPROVED BY	
DATE	03-29-94		DRAWING NUMBER	498452
SHEET	OF			

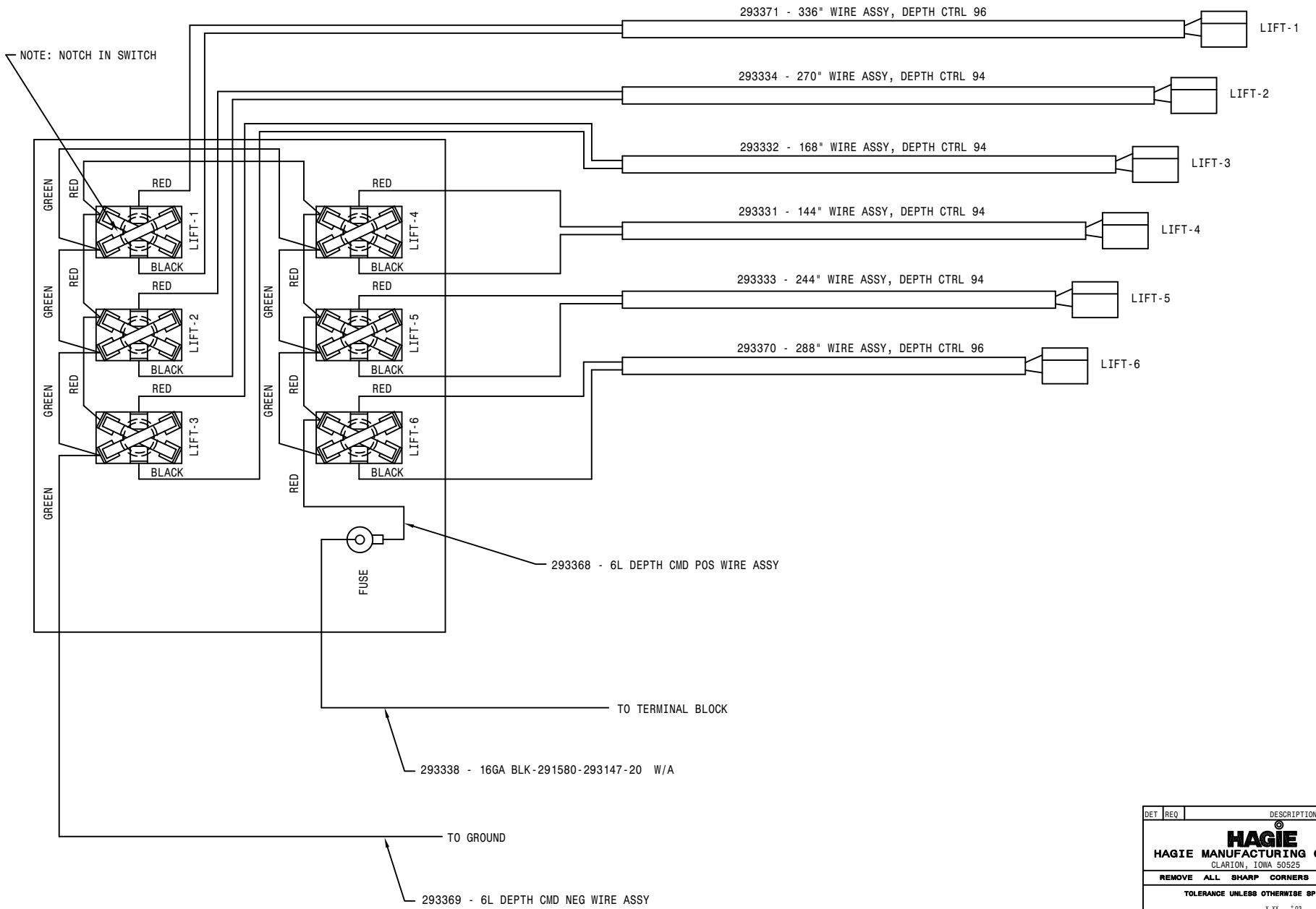

DET	REQ	DESCRIPTION
HAGIE HAGIE MANUFACTURING COMPANY CLARION, IOWA 50525		
REMOVE ALL SHARP CORNERS & BURRS		
TOLERANCE UNLESS OTHERWISE SPECIFIED		
FRACTION 1/32	DECIMALS X.XX	ANGLES 1°
	X.XXX	5.005
DESCRIPTION		
WIRE DIAG, 6-LIFT DEPTH CMD 96		
DRAWN BY T. MARKER	SCALE NONE (1)	
CHECKED BY	APPROVED BY	
DATE 02-26-96	DRAWING NUMBER 498479	
SHEET	OF	

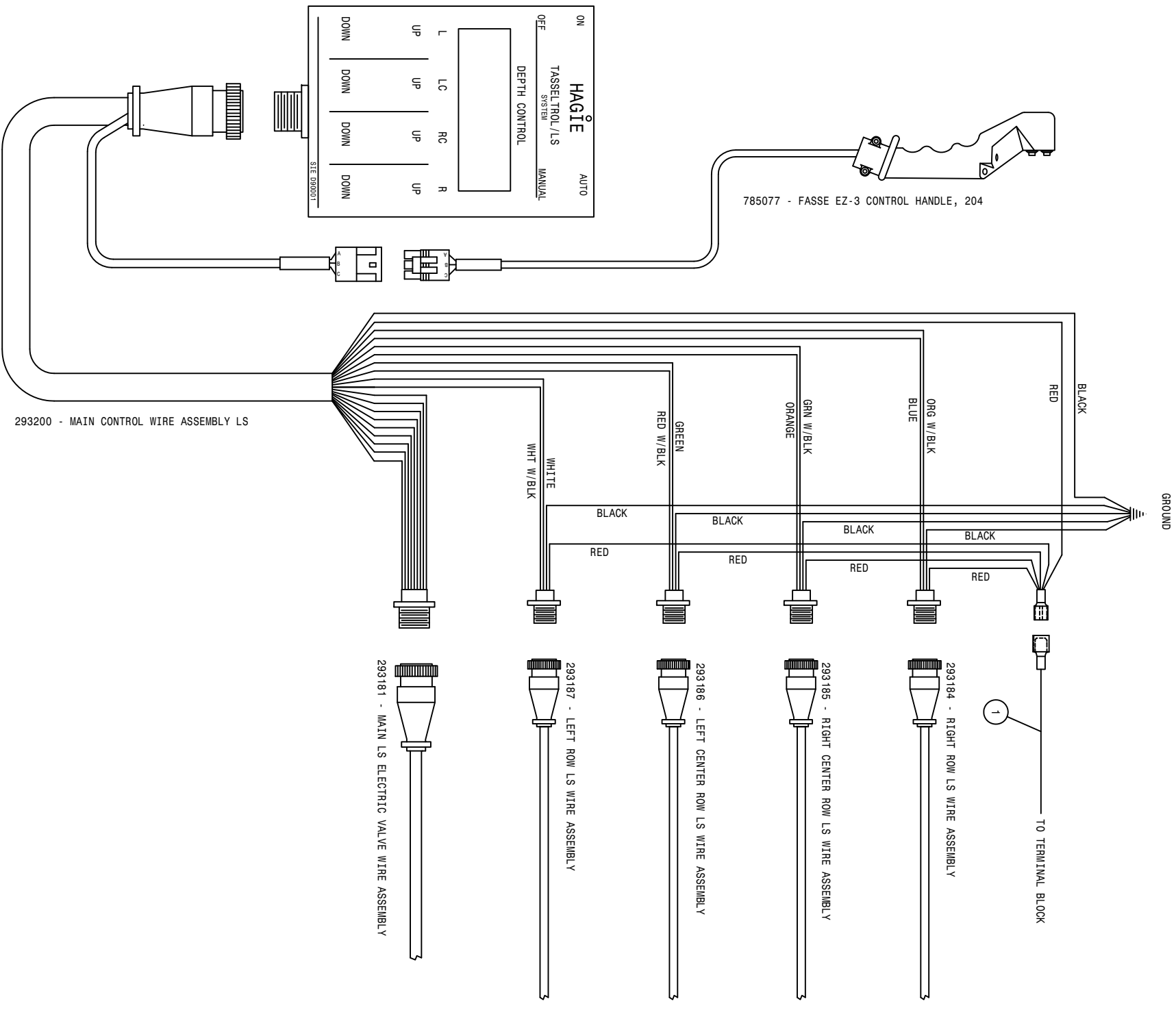

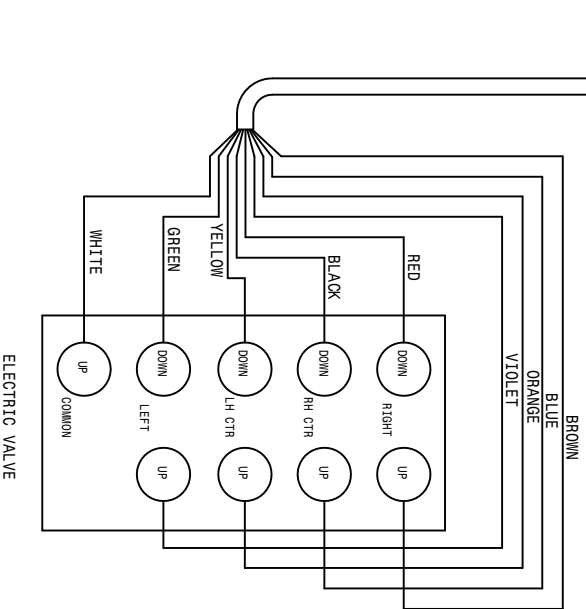
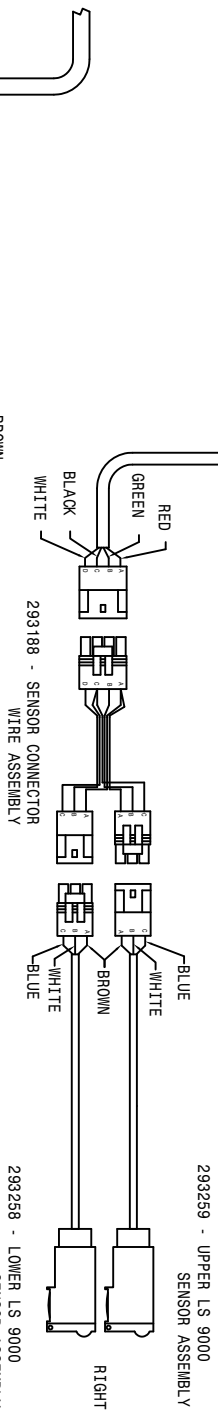
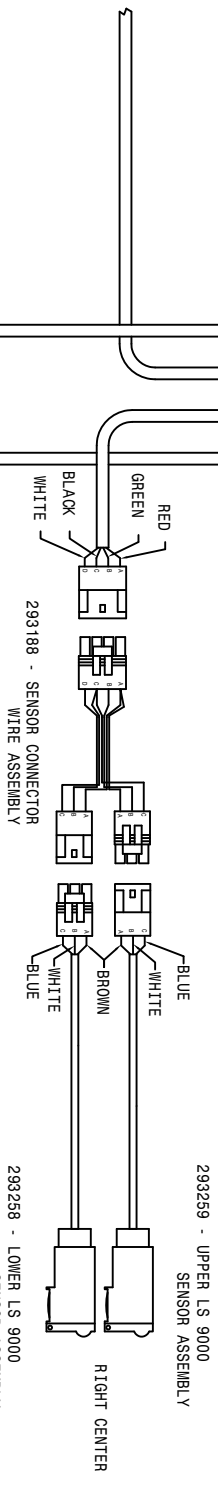
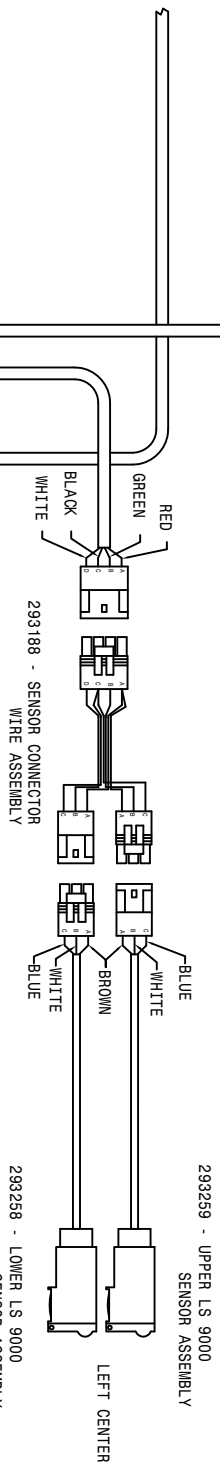
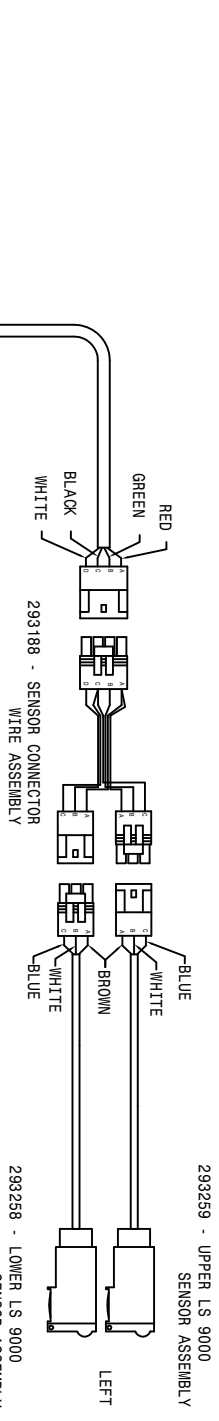

1	1	293329	16GA BLK-29157-293163-4A	DESCRIPTION
LEFT	HEAD			
HAGIE				
HAGIE MANUFACTURING COMPANY				
CLARION, IOWA 50525				
REMOVE ALL SHARP CORNERS & BURRS				
TOLERANCE UNLESS OTHERWISE SPECIFIED				
FRACTION : 1/32		DECIMALS : X.XX		ANGLES : °
FRACTION : 1/64		DECIMALS : X.XXX		ANGLES : °
DESCRIPTION				
L.S. SYS WIRE DIA. 204 94				
DOWN BY LABELER	DATE	SCALE	DRAWING NUMBER	
DESIGNED BY	180_30_94	ASSEMBLED BY	498454	
CHECKED BY				
SHEET	OF			

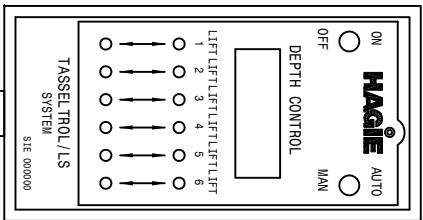

293378 - REMOTE DISPLAY CABLE, 6L L/S

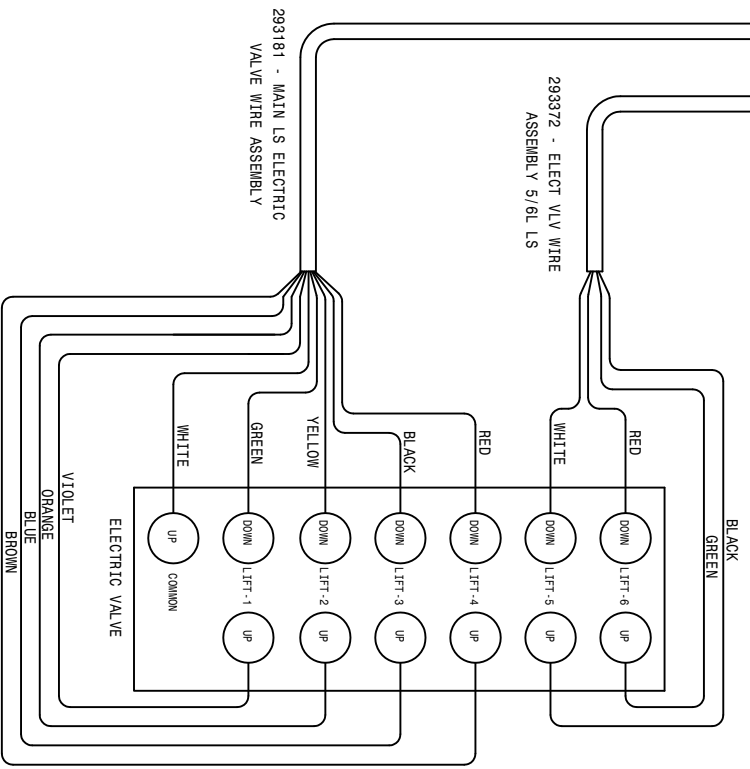
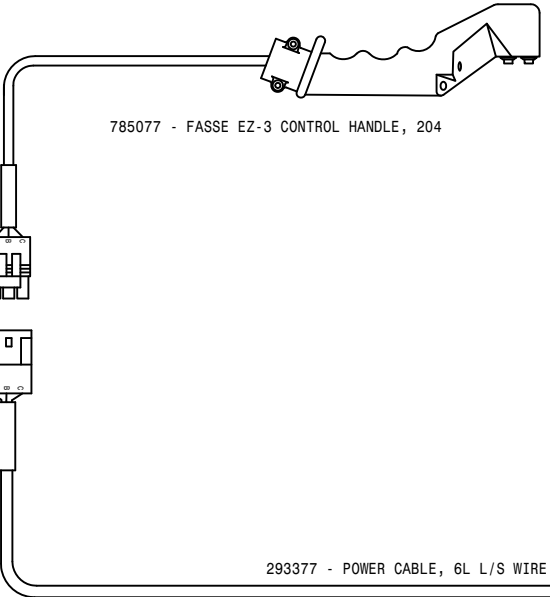
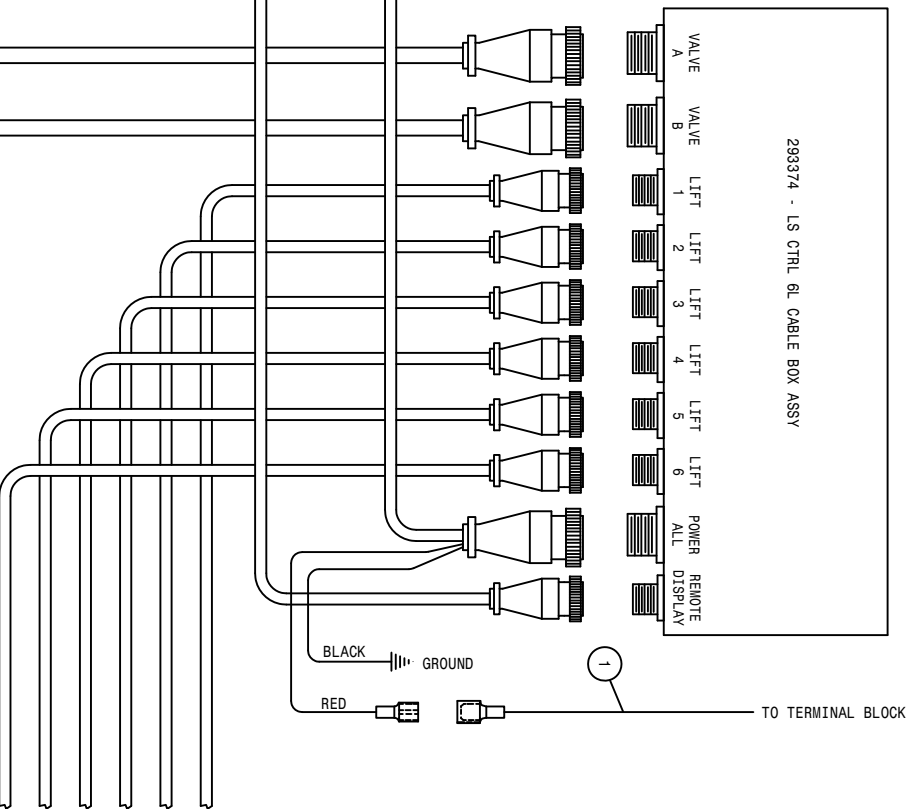

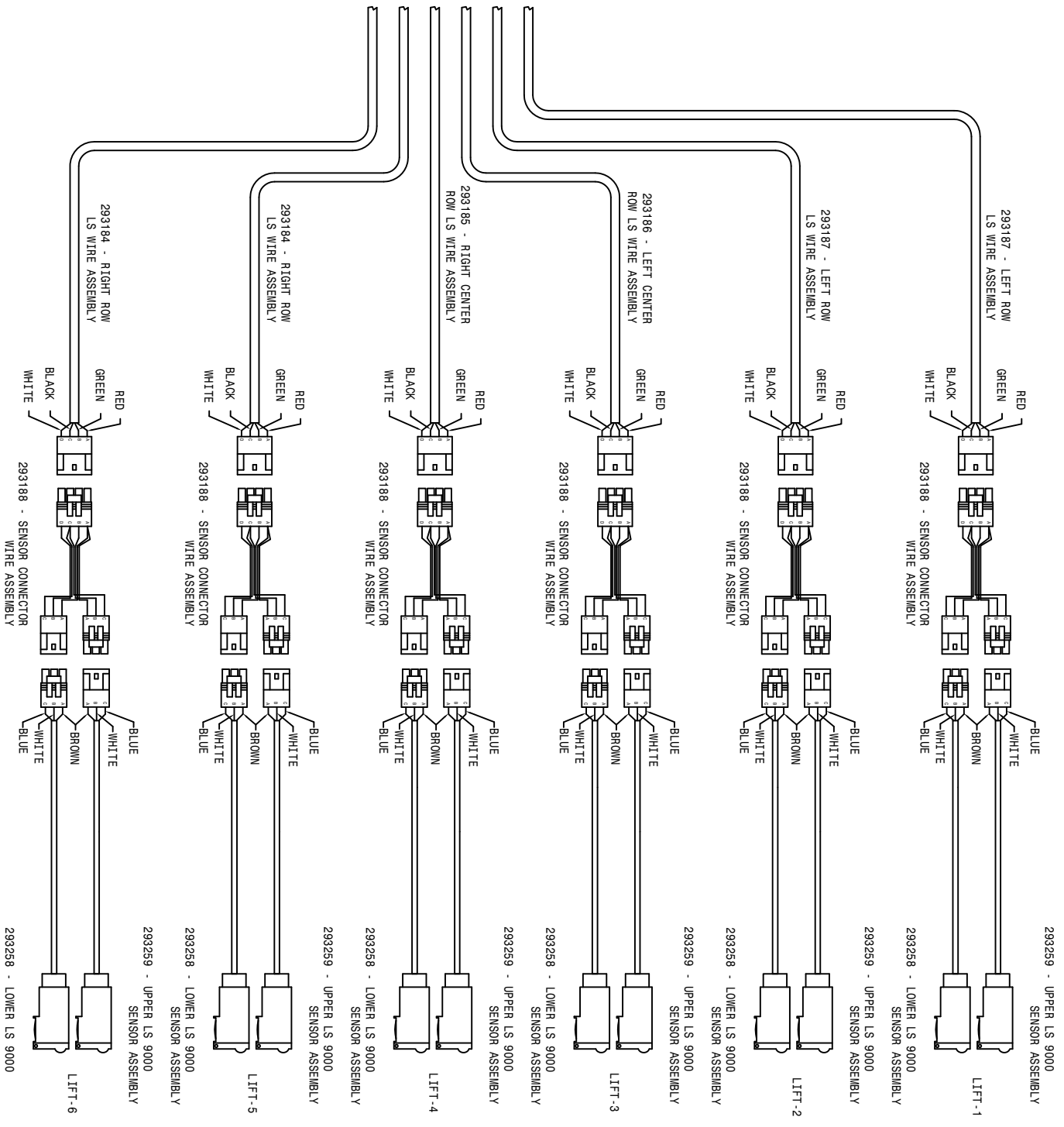

1	1	293259	16CN BLK-29157-293163-44	DESCRIPTION
DET	REQ			
HAGIE				
HAGIE MANUFACTURING COMPANY				
CARLTON, IOWA 50555				
REMOVE ALL SHARP CORNERS & BURRS				
TOLERANCE UNLESS OTHERWISE SPECIFIED				
FINISH	1:100	GEOMETRIC	FINISH	1:100
DATE	05-01-96	DESIGNED BY	APPROVED BY	
SHEET	02	498509		

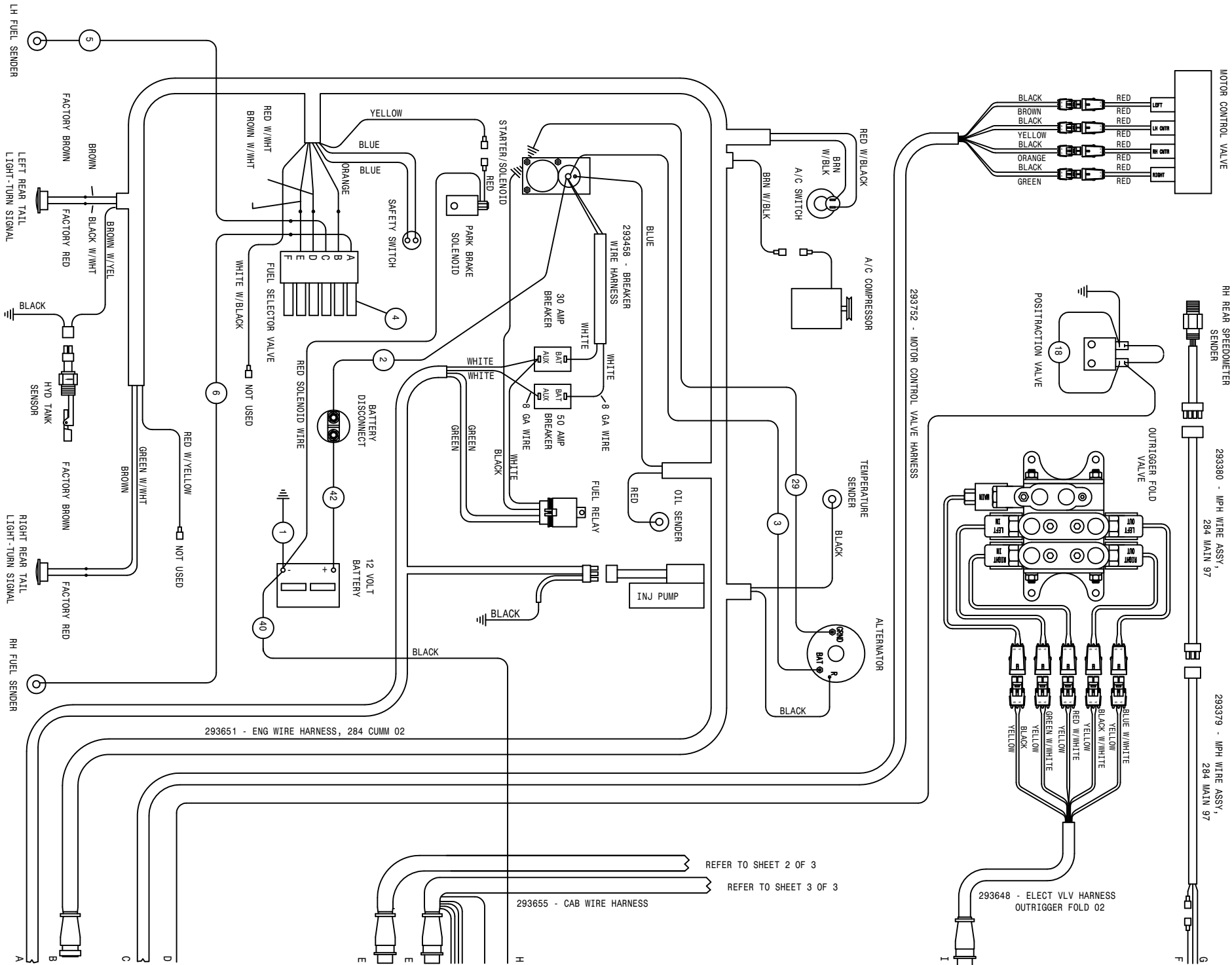

REFER TO SHEET 2 OF 3

REFER TO SHEET 3 OF 3

293655 - CAB WIRE HARNESS

293651 - ENG WIRE HARNESS, 284 CUMM 02

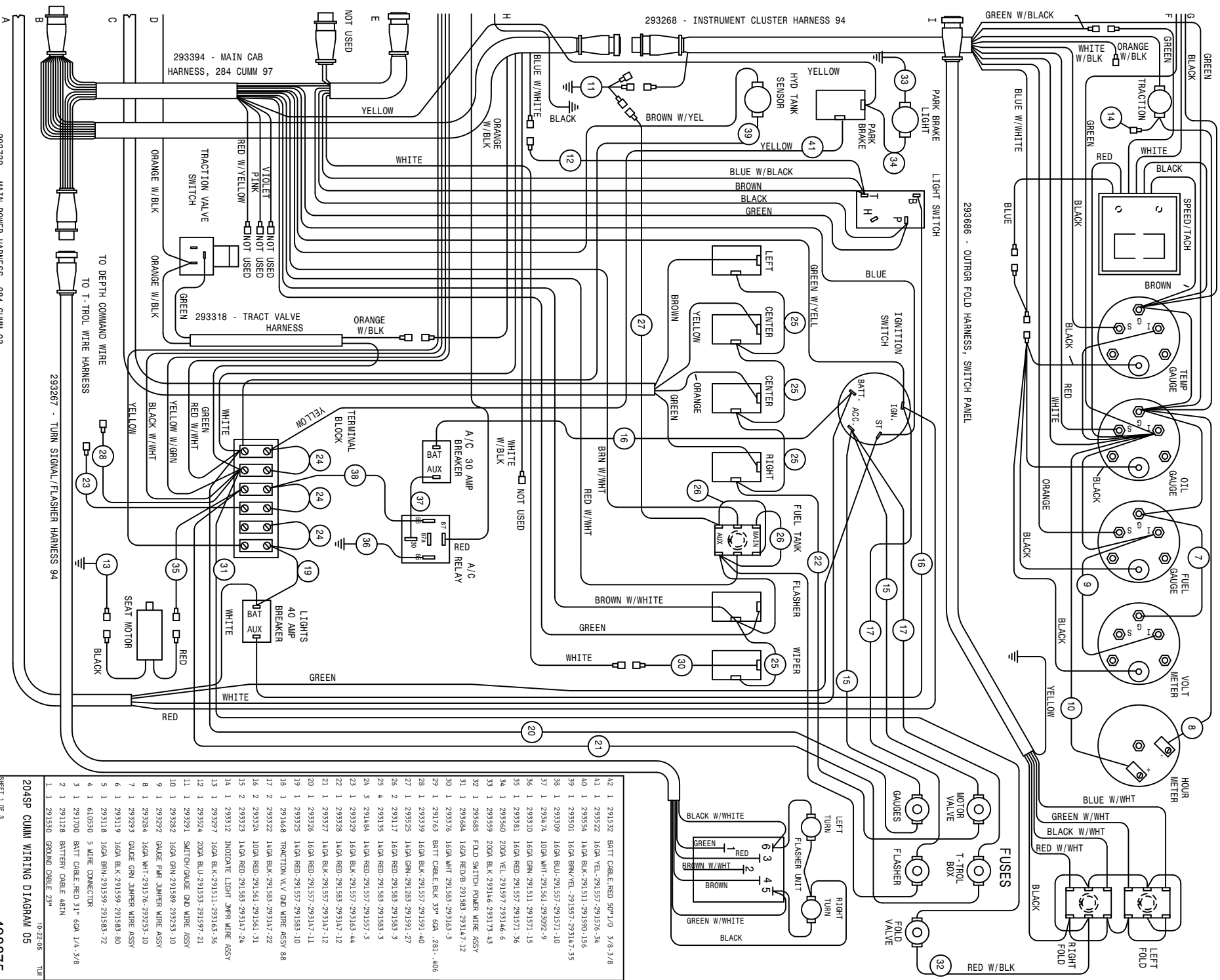

42	1	291532	BATT CABLE, RED 50M L/O	3/6-3/8
41	1	293522	16GA VEL.-291557-291576-34	
40	1	293554	16GA BLK.-291511-291590-156	
39	1	293501	16GA BRN/VEL.-291557-293147-35	
38	1	293509	16GA BLU.-291557-291571-10	
37	1	293474	10GA WH.-291561-293092-9	
36	1	293110	16GA GRN.-291511-291571-115	
35	1	293381	16GA RED.-291577-291571-36	
34	1	293560	20GA VEL.-291597-293146-6	
33	1	293559	20GA BLK.-293146-293173-43	
32	1	293465	FOLD SWITCH PULLER WIRE ASSY	
31	1	293684	16GA RED/BL.-291583-293147-12	
30	1	293376	16GA WH.-291583-293163-3	
29	1	291763	BATT CABLE, BLK 33M 6GA .281-.406	
28	1	293339	16GA BLK.-291577-291591-40	
27	1	293525	14GA GRN.-291283-291591-27	
26	2	293117	16GA RED.-291583-291583-3	
25	4	293135	14GA RED.-291583-291583-3	
24	3	291484	14GA RED.-291577-291577-3	
23	1	293359	16GA GRN.-291557-293163-44	
22	1	293338	14GA RED.-291557-291547-12	
21	1	293327	14GA BLK.-291557-293147-12	
20	1	293356	16GA RED.-291557-293147-11	
19	1	293325	14GA RED.-291557-291583-10	
18	1	291468	TRACTION VLV GND WIRE ASSY 88	
17	2	293322	14GA BLK.-291561-291547-22	
16	2	293324	10GA RED.-291561-291561-31	
15	2	293323	14GA RED.-291583-293147-24	
14	1	293312	INDICATOR LIGHT 2MR WIRE ASSY	
13	1	292927	16GA BLK.-291511-291634-36	
12	1	293524	20GA BLU.-291555-291571-21	
11	1	293291	SMITG/CABLE GND WIRE ASSY	
10	1	292828	16GA GRN.-291589-293253-10	
9	1	293292	CABLE PARK JAMPER WIRE ASSY	
8	1	293284	16GA WH.-291576-293253-10	
7	1	293293	CABLE GRN JAMPER WIRE ASSY	
6	1	293119	16GA BLK.-291559-291583-80	
5	1	293118	16GA BRN.-291559-291583-72	
4	1	610590	5 WIRE CONNECTOR	
3	1	291700	BATT CABLE, RED 31M 6GA 1/4-3/8	
2	1	291128	BATTERY CABLE, 48IN	
1	1	291530	GROUND CABLE 23"	

204SP CUMM WIRING DIAGRAM 05
 10-22-05 TUL
 SHEET 1 OF 3
 REVISION DATE: 06-09-05

293730 - MAIN POWER HARNESS, 284 CUMM 03
 293267 - TURN SIGNAL/FLASHER HARNESS 94
 293394 - MAIN CAB HARNESS, 284 CUMM 97
 293318 - TRACT VALV HARNESS
 293268 - INSTRUMENT CLUSTER HARNESS 94
 293686 - OUTROR FOLD HARNESS, SWITCH PANEL

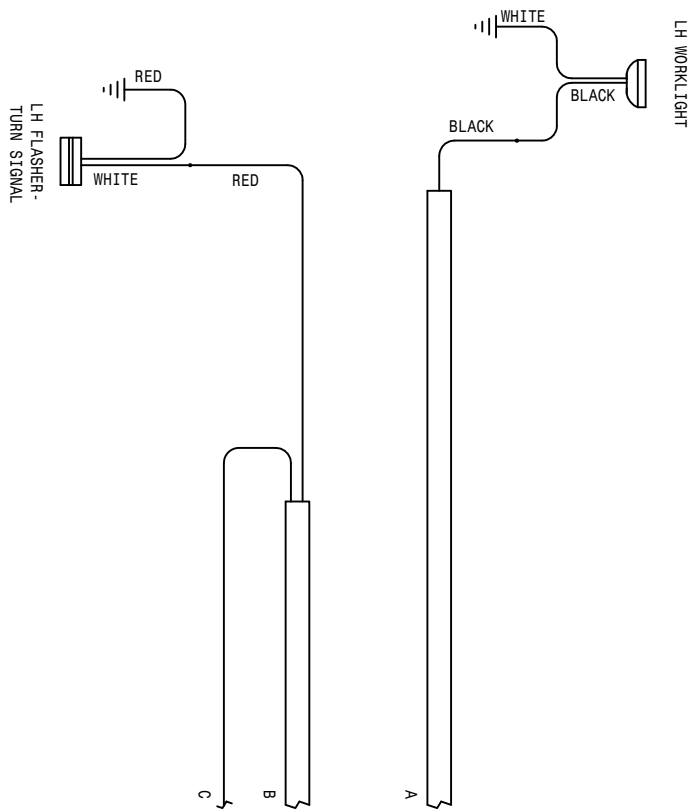
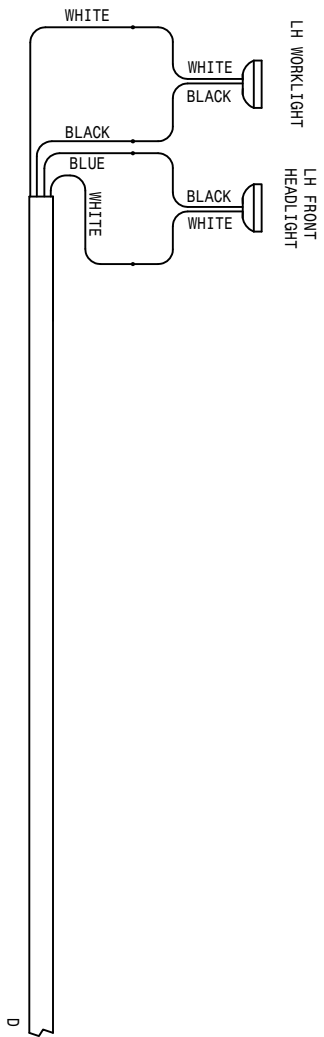
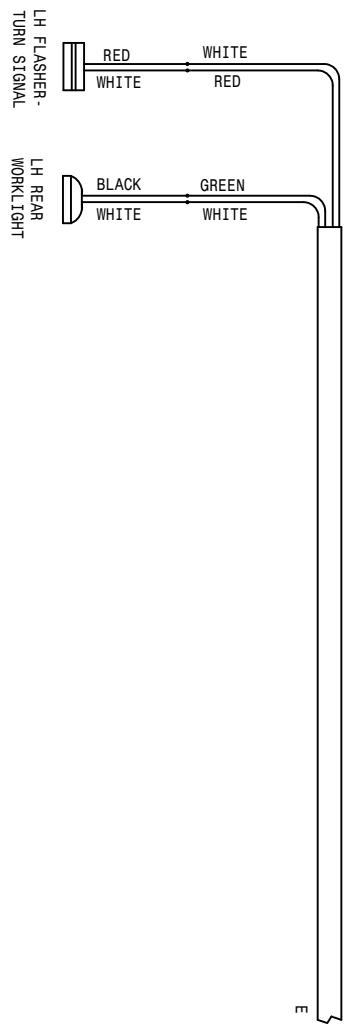

OPERATOR STATION LIGHT WIRING DIAGRAM

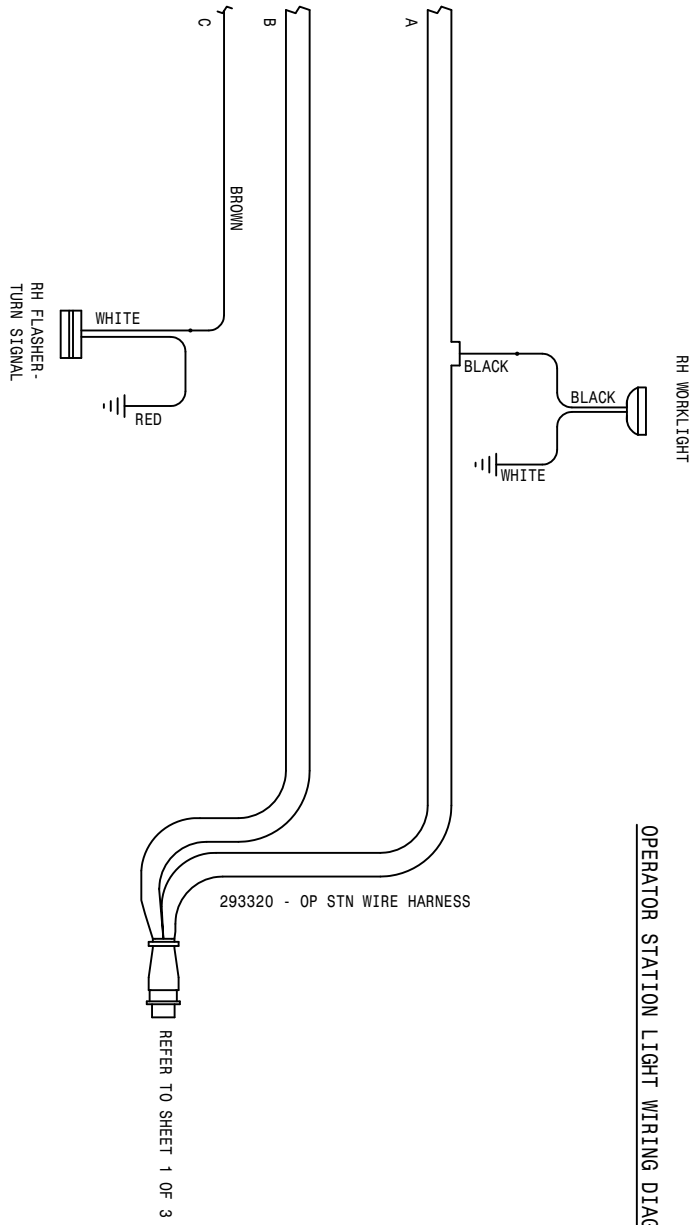

CANOPY LIGHT WIRING DIAGRAM
ROPS LIGHT WIRING DIAGRAM

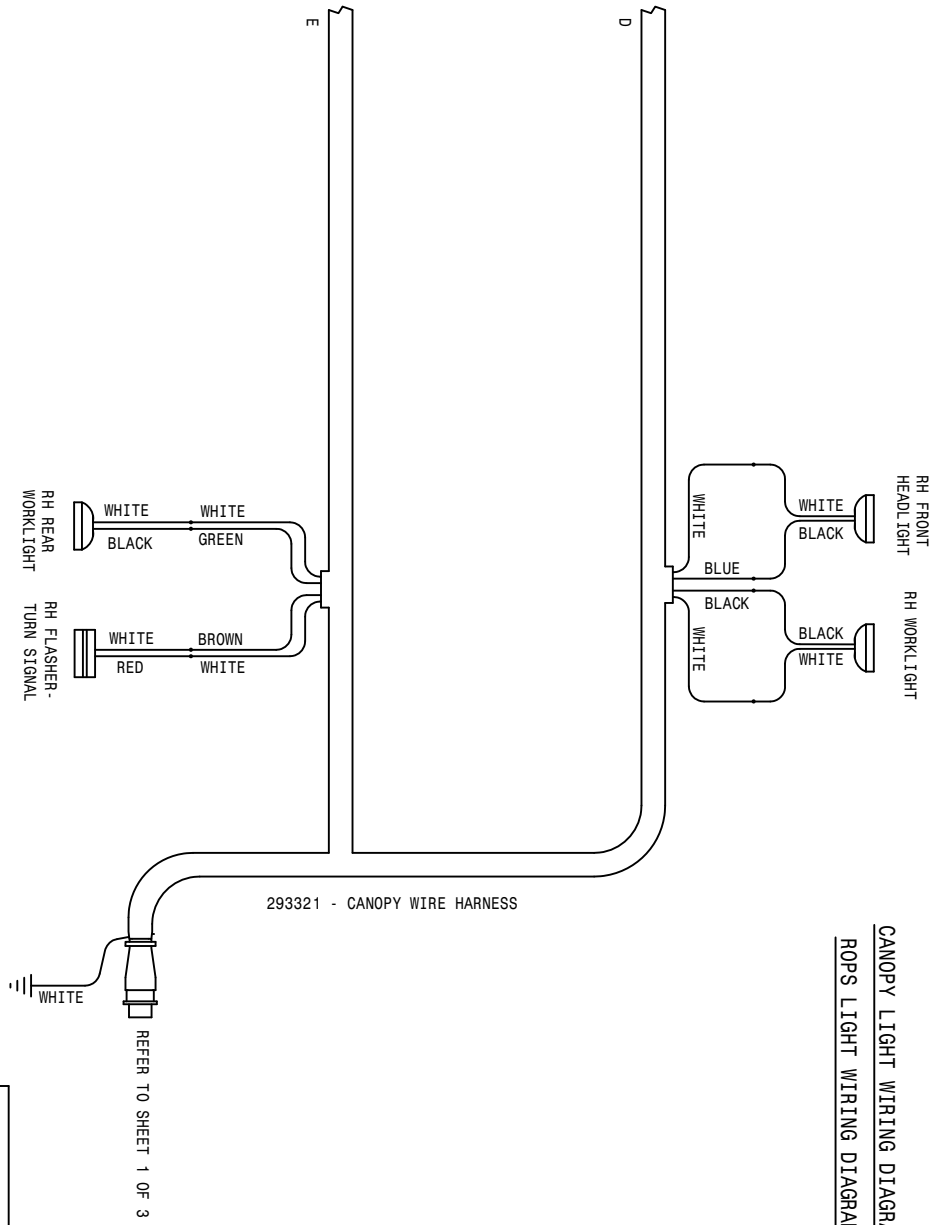

204SP CUMM WIRING DIAGRAM 05
SHEET 2 OF 3
REVISION DATE:
498875
10-22-04 TLD

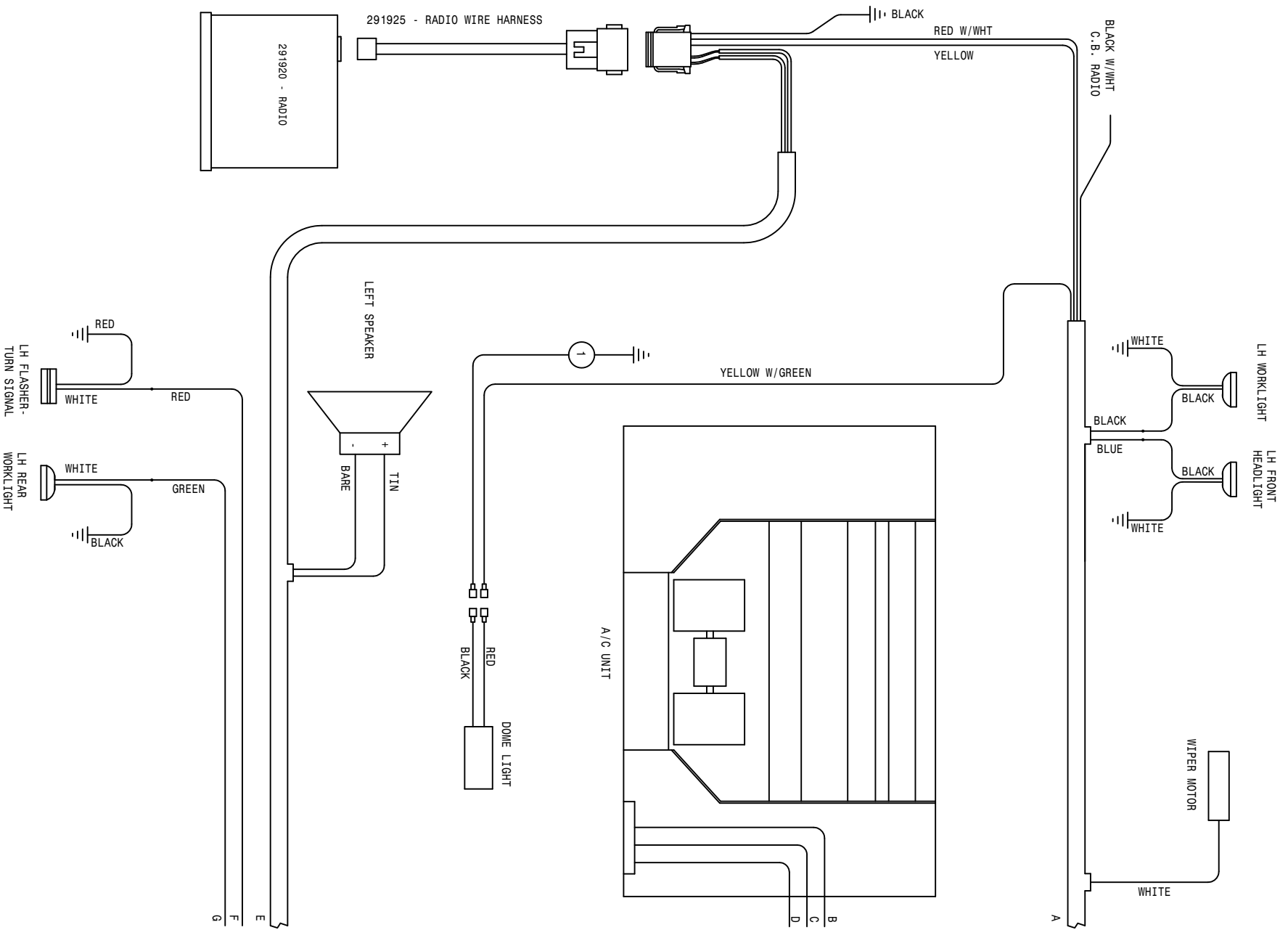

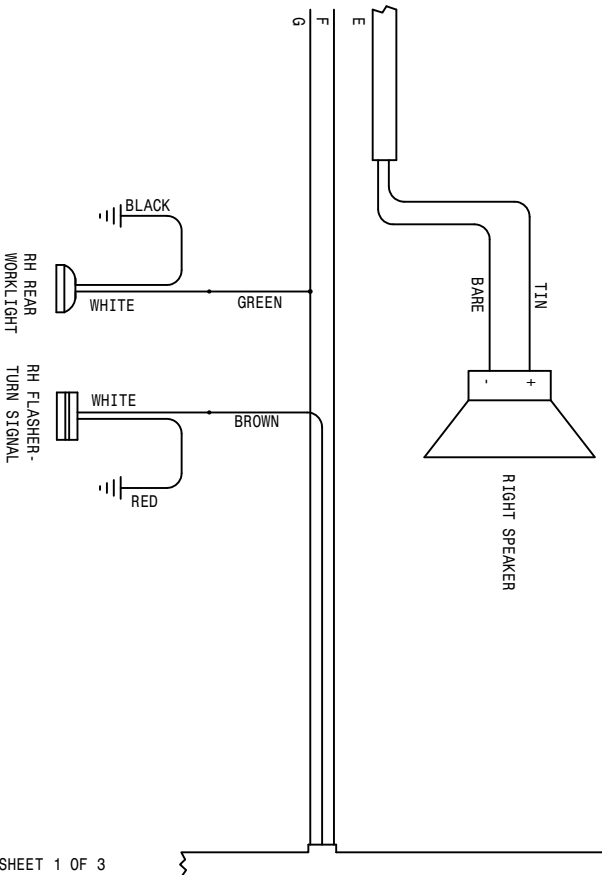
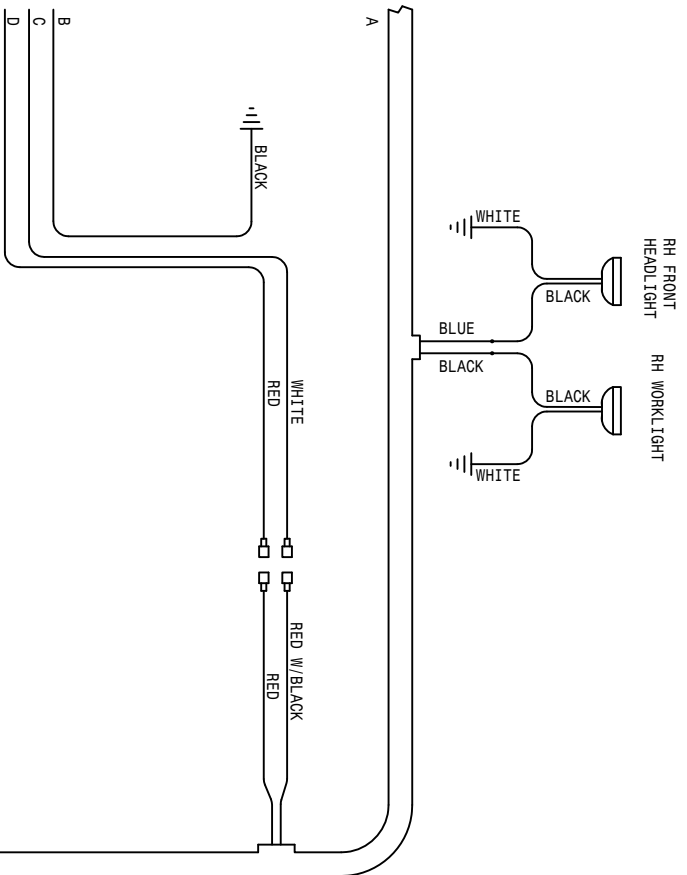

293826 - CAB WIRE HARNESS 204/DTS8 05

REFER TO SHEET 1 OF 3

1	1	293299	16GA	BLK-291511-291571-30	10-25-04	TUM
204SP CUMM WIRING DIAGRAM 05						
SHEET 3 OF 3						498875
REVISION DATE:						

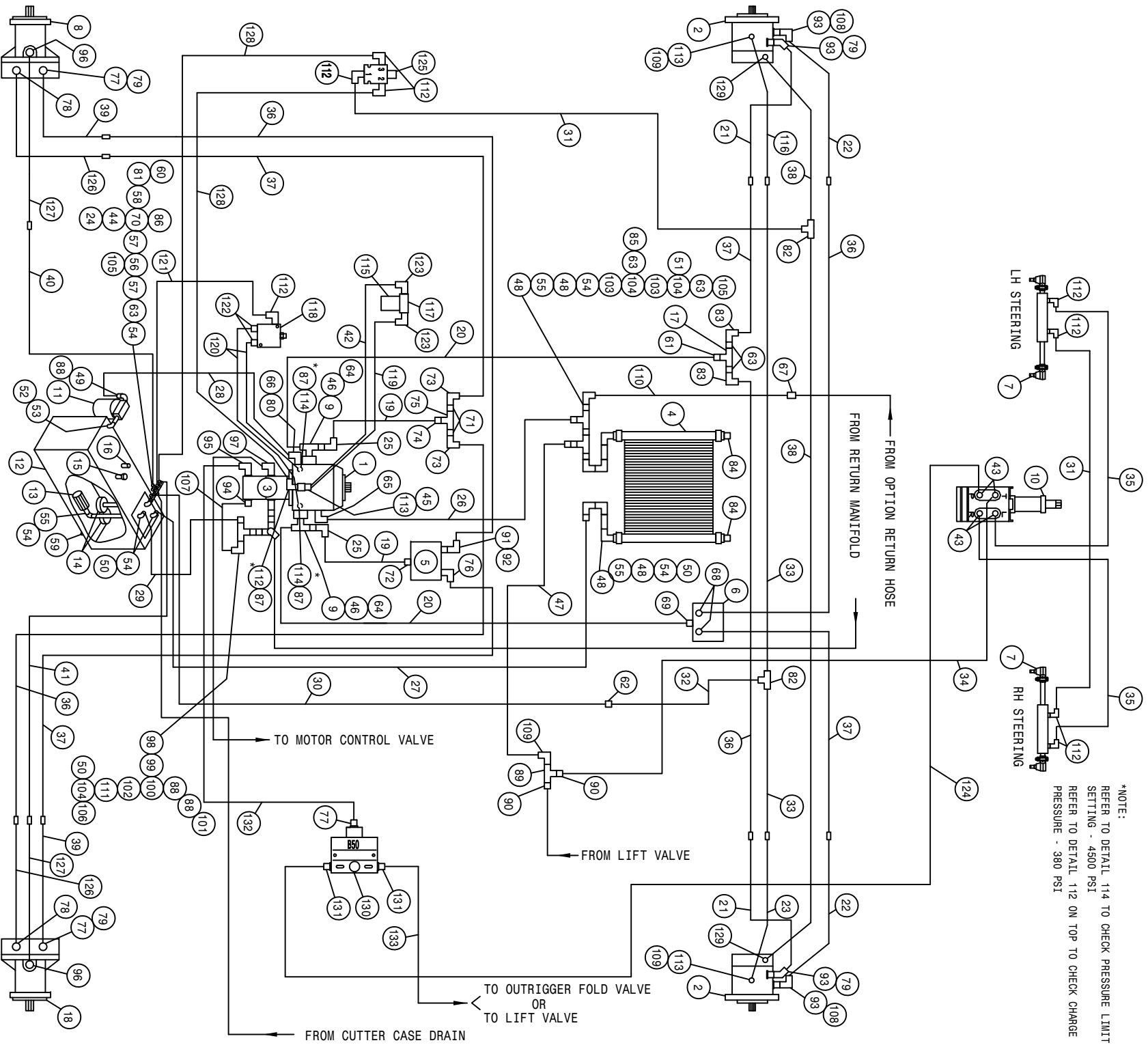

204SP BASIC MACHINE CUMM HYD SCHEMATIC 2004
REFERENCE DRAWING NO. 498794

DET.	QTY	PART NO.	DESCRIPTION	DET.	QTY	PART NO.	DESCRIPTION
1	1	606902	SUND 100CC PUMP,B-WT W/FILT	68	2	618601	7/8MJIC-1 5/16MOR ADPT
2	2	610717	TORQ HUB,24:1 W/M1 INTEGRATED	69	1	618186	1 5/16MJIC-1 5/16MOR ADPTR
3	1	606937	TANDEM PUMP, 606929 & 606938	70	1	504400	BLK PIPE CROSS .75NPT
4	1	618606	OIL COOLER, BLISSFIELD 65027	71	2	505005	RED BUSH 1 TO 1 1/2
5	1	610585	POSITRACTION VLV,44SP	72	2	618308	1 1/16MJIC-1 5/16MOR ADPTR
6	1	610586	POSITRACTION VLV,ALUM,88SP60G	73	2	611124	7/8MJIC-.90-1/2MNP LBO
7	2	621516	STRG CYL ASSY, 2100	74	1	618434	1 1/16MJIC-1MNP ADPTR
8	1	610567	SUND M25-3000 WHL MTR 1.5CI	75	1	618575	1FNPT PIPE TEE STL
9	2	618598	1" 4-BOLT FLG X 1 5/16 FOR	76	1	618589	7/8MJIC-.90-1 5/16MOR LBO
10	1	749318	STRG MTR,7.3CID,NON-LOAD 1031	77	3	611126	7/8MJIC-.7/8MOR ADPTR
11	1	605601	PARKER FILTER ASSY,10M,1.25NPT	78	2	618644	7/8MJIC-.45-7/8MOR LBO
12	1	760264	HYD TANK WLD,204/254/284 2002	79	4	618628	7/8MJIC-.45-7/8FJIC SMIV LBO
13	1	605600	TANK FILTER, 100 MESH,1"FNPT	80	1	618639	1 5/8MOR-1 5/16FOR ADPTR
14	2	605603	LINE SUMP DIFFUSER	81	1	618018	9/16MJIC-1/2MNP ADPTR
15	1	611052	FILLER BREATHER 3/4NPT	82	2	618019	9/16MJIC UNION TEE
16	1	614453	DIPSTICK, 8IN	83	2	618156	7/8MJIC-.90-3/4MNP LBO
17	1	614660	1IN STL TEE WLD 280	84	2	505102	PIPE PLUG 1.00NPT SQ HD
18	1	610721	SUND M25-3000 WHL MTR W/SENSOR	85	1	610300	3/4MJIC-.3/4MNP ADPTR
19	2	614707	HYD TUBE ASSY,SUND,200 DIESEL	86	1	618135	3/4 HOSE BARB-90-3/4MNP
20	2	615634	12TMM-16FJX-16FJX-123	H/A	87	618531	9/16FJIC CAP NUT
21	2	615803	FRT LEG OUTER HYD TUBE 204SP	88	3	506410	BLK PIPE ST EL 90DEG 1.25NPT
22	2	615802	FRT LEG CNTR HYD TUBE 204SP	89	1	618311	3/4MJIC UNION TEE
23	1	615800	RH FRT LEG INNER HYD TUBE204SP	90	2	618482	3/4FJIC-.9/16MJIC ADPTR
24	1	618520	1/4MNP RUN TEE-9/16MJIC	91	1	618312	1 5/16MOR-1 1/16FOR ADPTR
25	2	618191	1 1/16MJ-90-1 1/16FJ SMIV LBO	92	1	618535	7/8MJIC-.90-1 1/16MOR LBO
26	1	601395	HOSE, 3/4 X 64 1FBR-1SP1	93	4	618309	7/8MJIC-1 1/16MOR ADPTR
27	1	601396	HOSE, 1 X 81 1FBR-1SPI	94	1	618078	3/4 HOSE BARB-1 1/16MOR
28	1	601376	HOSE, 1 X 29 1FBR-1SPI	95	1	611128	7/8MJIC-.90-7/8MOR LBO
29	1	601377	HOSE, 1 X 48 1FBR-1SPI	96	2	618315	3/4MJIC-.45-3/4MOR LBO
30	1	614388	08C1T-.08FJX-.08FJX-129	H/A	97	618178	1 5/16MJIC-.90-1 5/16MOR LBO
31	2	611246	04C1T-.06FJX-.06FJX-174	H/A	98	618596	1 5/8MOR-1 1/4FNPT ADPTR
32	1	614625	06C1T-.06FJX-.06FJX-30	H/A	99	507026	1 1/4MNP HEX PIPE NIPPLE STL
33	2	616156	06C1T-.06FJX-.08MJ-92	H/A	100	616701	SIDE OUTLET EL 90DEG 1.25NPT
34	1	611204	04C1T-.06FJX-.06FJX-78	H/A	101	715660	HOSE BARB 1 1/4NPT X 1 1/4
35	2	614639	04C1T-.06FJX-.06FJX-126	H/A	102	506005	1 1/4 TO 1 RED BUSH BLK MAL
36	4	616160	08C2AT-.10FJX-.10MJ-105	H/A	103	505201	CLOSE NIPPLE 1.00NPT
37	4	616159	08C2AT-.10FJX-.10MJ-98	H/A	104	505101	BLK PIPE TEE 1.00NPT
38	2	614076	04C1T-.06FJX-.06FJX-119	H/A	105	610305	3/4MJIC-.90-3/4MNP LBO
39	2	615804	REAR LEG INNER HYD TUBE 204SP	106	1	716000	3/4 HOSE BARB-90-1MNP
40	1	616158	06C1T-.06FJX-.08MJ-120	H/A	107	601399	HOSE, 3/4 X 13 1FBR-1SPI
41	1	616157	06C1T-.06FJX-.08MJ-106	H/A	108	618301	7/8MJIC-.90-7/8FJIC SMIV LBO
42	1	615633	08C1T-.08FJX-.08FJX-23	H/A	109	618609	3/4MJIC-.90-3/4FJIC SMIV LBO
43	4	618496	9/16MJIC-.45-3/4MOR LBO	110	1	614662	08C1T-.08FJX-.08FJX-72
44	1	504001	RED BUSH 3/4 X 1/4 BLK MAL	111	1	505105	1MNP HEX PIPE NIPPLE STL
45	1	618183	3/4MJIC-.90-7/8MOR LBO	112	9	618119	9/16MJIC-.90-9/16MOR LBO
46	2	618599	1 5/16MOR BRANCH TEE-1 5/16MJ	113	3	618327	3/4MJIC-.7/8MOR ADPTR
47	1	615465	08C1T-.08FJX-.08FJX-33	H/A	114	618629	9/16MOR BRANCH TEE-9/16MJIC
48	4	505200	BLK PIPE ST EL 90DEG 1.00NPT	115	2	605609	HYD FILTER ELEMENT, DONALDSON
49	1	715664	1 1/4 NPT X 1 HOSE BARB	116	1	615801	LH FRT LEG INNER HYD TUBE204SP
50	4	714560	1NPT X 1 HOSE BARB	117	1	605608	HYD FILTER HEAD, DONALDSON
51	1	714531	1 NPT X 3/4 HOSE BARB	118	1	610580	REMOTE FLUSHING VALVE, SUND
52	1	506602	PIPE NIPPLE 1 1/4NPT-2 1/2	119	1	616034	08C1T-.08FJX-.08FJX-17
53	1	506303	BLK PIPE EL 90DEG 1.25NPT	120	2	616253	04C2AT-.06FJX-.06FJX-23
54	6	505300	BLK PIPE EL 90DEG 1.00NPT	121	1	616048	04C1T-.06FJX-.06FJX-35
55	3	505203	BLK PIPE NIPPLE 1.00NPT-4.00	122	2	618126	9/16MJIC-.9/16MOR ADPTR
56	1	504955	BLK PIPE TEE .75NPT	123	2	618474	3/4MJIC-.90-1 1/16MOR LBO
57	2	504702	CLOSE NIPPLE .75NPT	124	1	616040	04C1T-.06FJX-.06FJX-67
58	1	504210	RED BUSH 3/4 NPT X 1/2 NPT	125	1	610318	HYD SOLE VLV,2P-3W,9/16FOR,12V
59	1	470308	1/2MNP DRAIN PLUG,AL HD,MAG	126	2	615805	REAR LEG CNTR HYD TUBE 204SP
60	1	618486	9/16FJIC SW RUN TEE-9/16MJIC	127	2	615806	REAR LEG OUTER HYD TUBE 204SP
61	1	618322	1 5/16MJIC-1MNP ADPTR	128	2	616056	04C1T-.06FJX-.06FJX-32
62	1	618551	3/4MJIC-.9/16MJIC REDU UNION	129	2	618304	9/16MJIC-.7/16MOR ADPTR
63	5	505213	RED BUSH 1 X 3/4 BLK MAL	130	1	607504	FLO DIV B50 2-8GPM 7/8 FOR
64	2	618541	1 5/16FJIC-1 1/16MJIC ADPTR	131	2	618310	9/16MJIC-.7/8MOR ADPTR
65	1	618118	3/4 HOSE BARB-90-1 1/16MOR	132	1	614664	10C1T-.10FJX-.10FJX-98
66	1	618638	1IN HOSE BARB-45-1 5/16MOR	133	1	615616	04C1T-.06FJX-.06FJX-65
67	1	618314	3/4MJIC UNION				

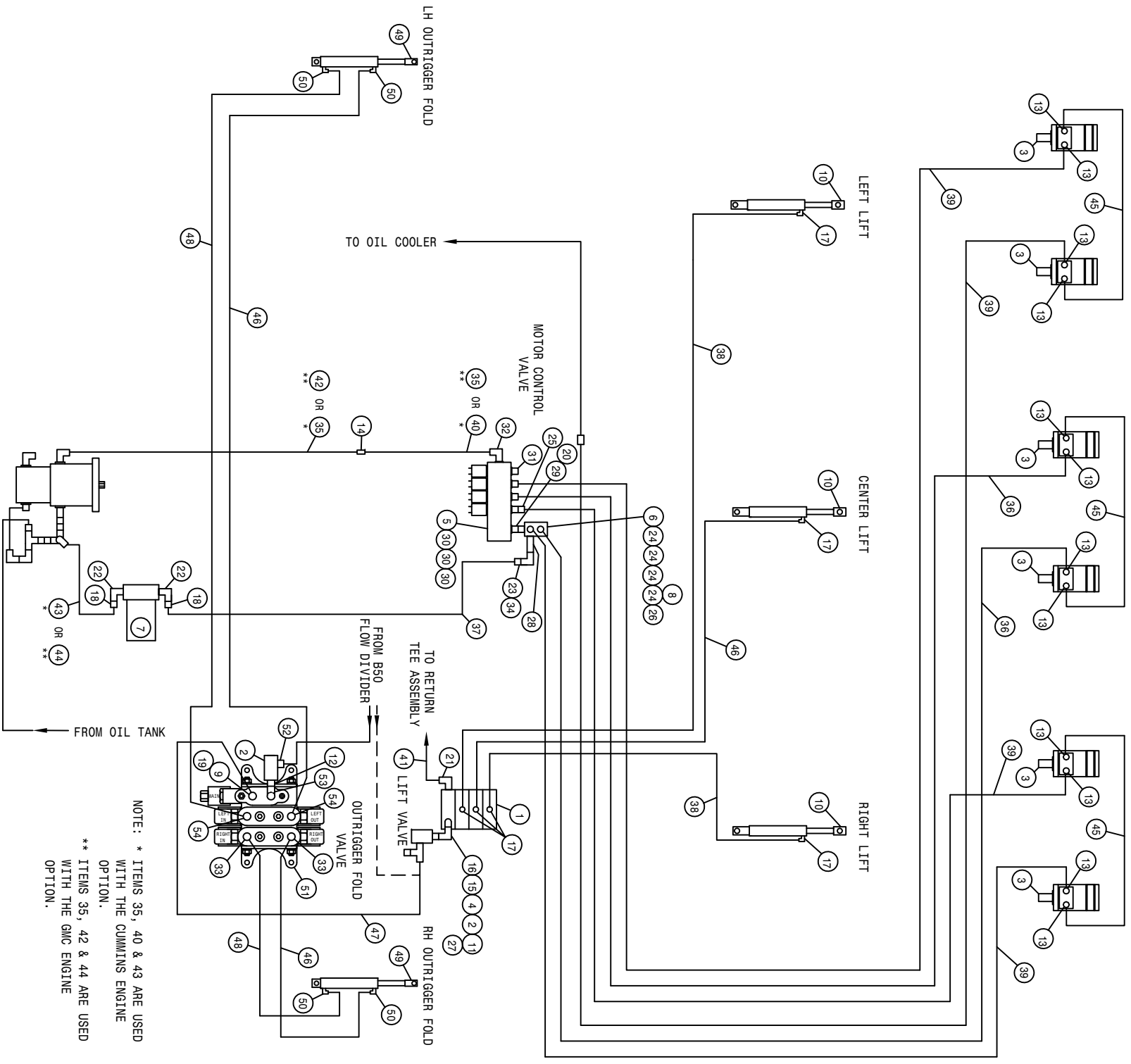

NOTE: * ITEMS 35, 40 & 43 ARE USED WITH THE CUMMINS ENGINE OPTION.
 ** ITEMS 35, 42 & 44 ARE USED WITH THE GMC ENGINE OPTION.

204 6R QUAD 3L LS HYD SCHEM 2004
REFERENCE DRAWING NO. 498796

DET.	QTY	PART NO.	DESCRIPTION	DET.	QTY	PART NO.	DESCRIPTION
1	1	610532	ELECT HYD STACK VLV, 3 SECT	*28	1	505209	BLK PIPE NIPPLE 1.00NPT-6.00
2	2	605615	HYD FILTER, INLINE 25M 9/16FOR	29	1	618186	1 5/16MJIC-1 5/16MOR ADPTR
3	6	610547	HYD MOTOR 4.5CI 1IN SHFT	30	3	618469	3/4MJIC-1 1/16MOR ADPTR
4	1	618668	9/16FJIC SWIV-9/16MOR ADPTR	31	1	610186	1 1/16MOR PLUG
5	1	606034	MTR CONTROL ELECT VLV	32	1	618178	1 5/16MJIC-90-1 5/16MOR LBO
*6	1	614633	HYD MANIF 8200 86	33	2	618115	9/16MJIC-90-3/4MOR LBO
*7	1	605601	PARKER FILTER ASSY, 10M, 1.25NPT	*34	1	714561	1.00NPT-1.25 HOSE BARB
*8	1	618532	3/4FJIC CAP NUT	35	1	614350	16C2AT-16FJX-16FJX-55
9	1	618310	9/16MJIC-7/8MOR ADPTR	36	2	614688	08C1T-08FJX-08FJX-108
10	3	621506	LIFT CYL ASSY 1M, DETASSELER	37	1	601378	HOSE, 1 1/4 X 156 1FBR-1SPI
11	1	618444	9/16MOR RUN TEE-9/16MJIC	38	2	614101	04C1T-06FJX-06FJX-133
12	1	618692	3/4FJIC SWIV-9/16MOR ADPTR	39	4	614690	08C1T-08FJX-08FJX-192
13	12	618327	3/4MJIC-7/8MOR ADPTR	40	1	614703	HYD TUBE ASSY, 200 MAIN
*14	1	618577	1 5/16MJIC UNION	*41	1	614627	06C1T-06FJX-06FJX-45
15	1	618440	9/16MJIC-90-9/16MOR EX LG LBO	42	1	614719	HYD TUBE ASSY, AUX 204 GMC
16	1	618170	3/4MOR-9/16FOR ADPTR	43	1	601437	HOSE, 1 1/4 X 40 1FBR-1SPI
17	6	618119	9/16MJIC-90-9/16MOR LBO	44	1	601440	HOSE, 1 1/4 X 25 1FBR-1SPI
*18	2	715660	HOSE BARB 1 1/4NPT X 1 1/4	45	3	616025	08C1T-08FJX-08FJX-50
19	1	618618	9/16MJIC-90-9/16FJIC SWIV LBO	46	3	614077	04C1T-06FJX-06FJX-88
*20	1	618587	1 5/16FJIC SWIV-1MNPT	47	1	615621	06C1T-06FJX-06FJX-24
21	1	618600	9/16MJIC-90-7/8MOR LBO	48	2	615727	04C1T-06FJX-06FJX-75
*22	2	506410	BLK PIPE ST EL 90DEG 1.25NPT	49	2	621520	BOOM HINGE FOLD CYL ASSY
*23	1	505300	BLK PIPE EL 90DEG 1.00NPT	50	4	614747	.025 ELBOW ASSY, 9/16MOR 90D
*24	4	611145	3/4MJIC-90-1/2MNPT LBO	51	1	606090	BRAND HYD VALVE, 2-SECT SER 36
25	1	618590	3/4MJIC-45-3/4FJIC SWIV LBO	52	1	618126	9/16MJIC-9/16MOR ADPTR
*26	1	503700	PIPE PLUG .50NPT SQ HD	53	1	618183	3/4MJIC-90-7/8MOR LBO
27	1	618531	9/16FJIC CAP NUT	54	2	618709	9/16MJIC-90-3/4MOR EX LG LBO

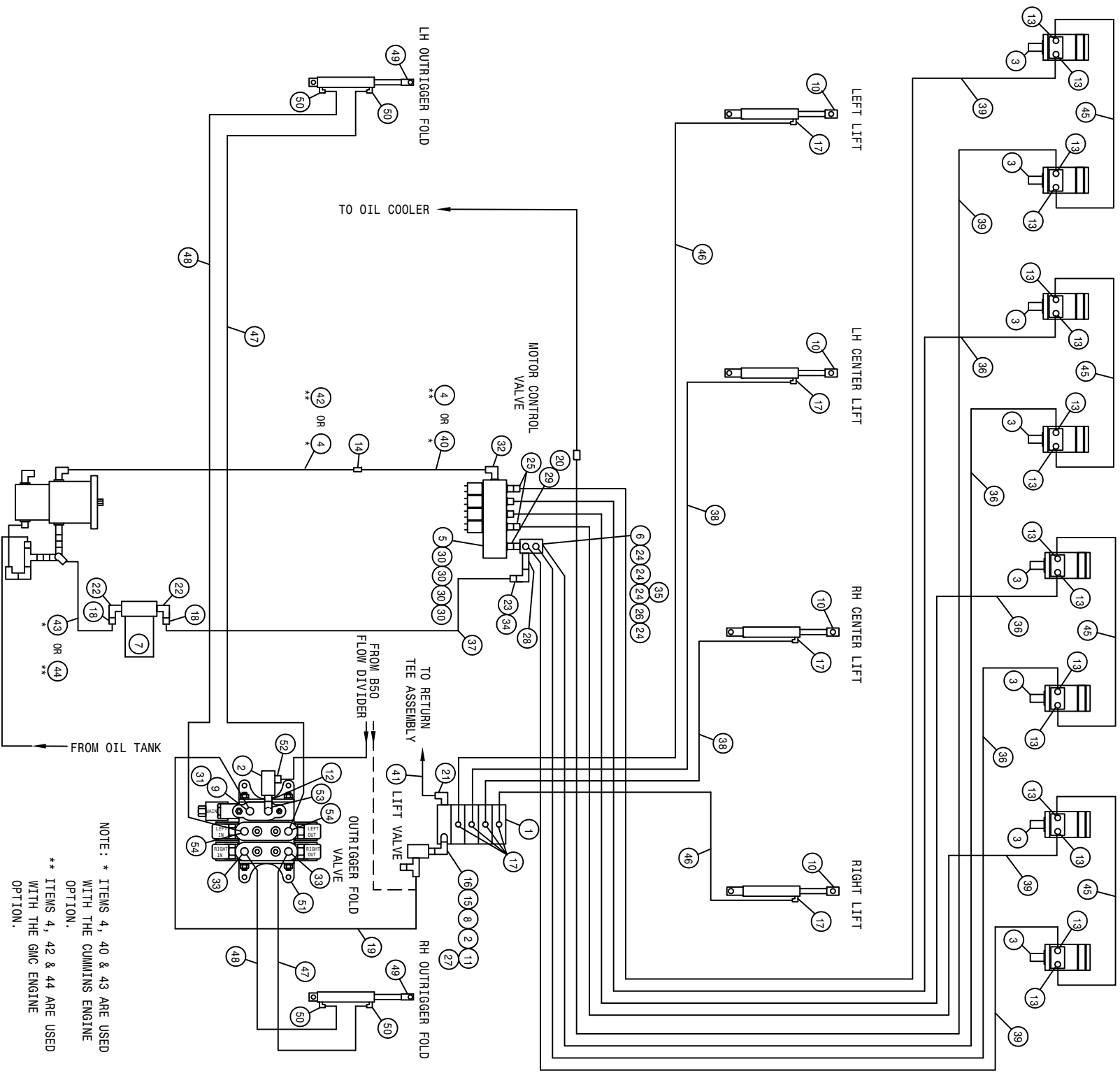

NOTE: * ITEMS 4, 40 & 43 ARE USED WITH THE CUMMINS ENGINE OPTION.
 ** ITEMS 4, 42 & 44 ARE USED WITH THE GMC ENGINE OPTION.

204 8R QUAD 4L LS HYD SCHEM 2004
REFERENCE DRAWING NO. 498797

DET.	QTY	PART NO.	DESCRIPTION	DET.	QTY	PART NO.	DESCRIPTION	
1	1	610613	ELECT HYD STACT VLV, 4 SECT	*28	1	505209	BLK PIPE NIPPLE 1.00NPT-6.00	
2	2	605615	HYD FILTER, INLINE 25M 9/16FOR	29	1	618186	1 5/16MJIC-1 5/16MOR ADPTR	
3	8	610547	HYD MOTOR 4.5CI 11N SHFT	30	4	618469	3/4MJIC-1 1/16MOR ADPTR	
4	1	614350	16G2AT-16FJX-16FJX-55	H/A	31	1	618618	9/16MJIC-90-9/16FJIC SWIV LBO
5	1	606034	MTR CONTROL ELECT VLV	32	1	618178	1 5/16MJIC-90-1 5/16MOR LBO	
*6	1	614633	HYD MAINIF 8200 86	33	2	618115	9/16MJIC-90-3/4MOR LBO	
*7	1	605601	PARKER FILTER ASSY, 10M, 1.25NPT	*34	1	714561	1.00NPT-1.25 HOSE BARB	
8	1	618668	9/16FJIC SWIV-9/16MOR ADPTR	*35	1	618532	3/4FJIC CAP NUT	
9	1	618310	9/16MJIC-7/8MOR ADPTR	36	4	614689	08C1T-08FJX-08FJX-120	
10	4	621506	LIFT CYL ASSY 1W,DETASSELER	*37	1	601378	HOSE, 1 1/4 X 156 1FBR-1SPI	
11	1	618444	9/16MOR RUN TEE-9/16MJIC	38	2	614101	04C1T-06FJX-06FJX-133	
12	1	618692	3/4FJIC SWIV-9/16MOR ADPTR	39	4	614691	08C1T-08FJX-08FJX-220	
13	16	618327	3/4MJIC-7/8MOR ADPTR	40	1	614703	HYD TUBE ASSY, 200 MAIN	
*14	1	618577	1 5/16MJIC UNION	*41	1	614627	06C1T-06FJX-06FJX-45	
15	1	618440	9/16MJIC-90-9/16MOR EX LG LBO	42	1	614719	HYD TUBE ASSY, AUX 204 GMC	
16	1	618170	3/4MOR-9/16FOR ADPTR	43	1	601437	HOSE, 1 1/4 X 40 1FBR-1SPI	
17	8	618119	9/16MJIC-90-9/16MOR LBO	44	1	601440	HOSE, 1 1/4 X 25 1FBR-1SPI	
*18	2	715660	HOSE BARB 1 1/4NPT X 1 1/4	45	4	616025	08C1T-08FJX-08FJX-50	
19	1	615621	06C1T-06FJX-06FJX-24	H/A	46	2	611246	04C1T-06FJX-06FJX-174
*20	1	618587	1 5/16FJIC SWIV-11MNP	47	2	614077	04C1T-06FJX-06FJX-88	
21	1	618600	9/16MJIC-90-7/8MOR LBO	48	2	615727	04C1T-06FJX-06FJX-75	
*22	2	506410	BLK PIPE ST EL 90DEG 1.25NPT	49	2	621520	BOOM HINGE FOLD CYL ASSY	
*23	1	505300	BLK PIPE EL 90DEG 1.00NPT	50	4	614747	.025 ELBOW ASSY, 9/16MOR 90D	
*24	4	611145	3/4MJIC-90-1/2MNP LBO	51	1	606090	BRAND HYD VALVE, 2-SECT SER	
25	2	618590	3/4MJIC-45-3/4FJIC SWIV LBO	52	1	618126	9/16MJIC-9/16MOR ADPTR	
*26	1	503700	PIPE PLUG .50NPT SQ HD	53	1	618183	3/4MJIC-90-7/8MOR LBO	
27	1	618531	9/16FJIC CAP NUT	54	2	618709	9/16MJIC-90-3/4MOR EX LG LBO	

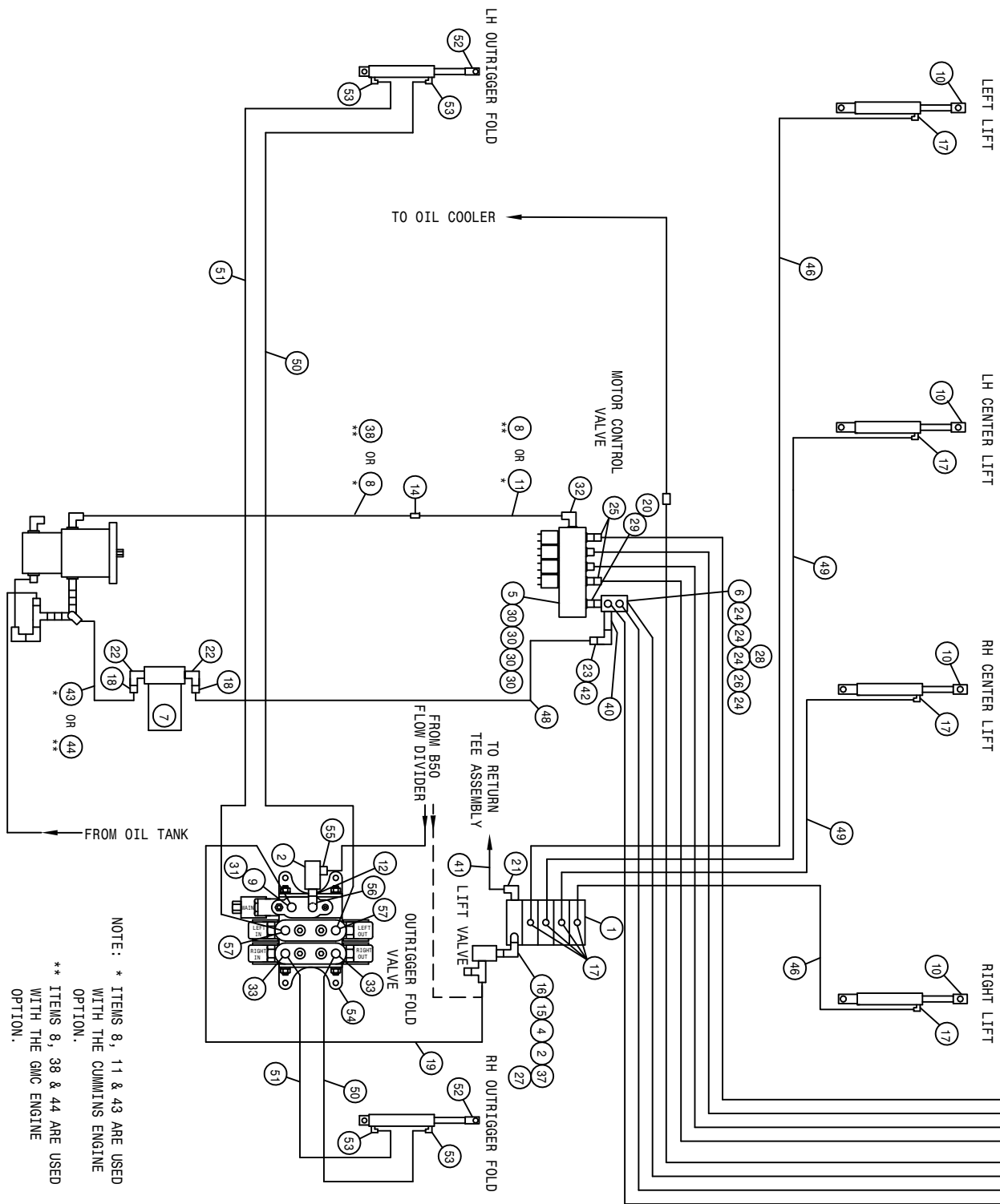
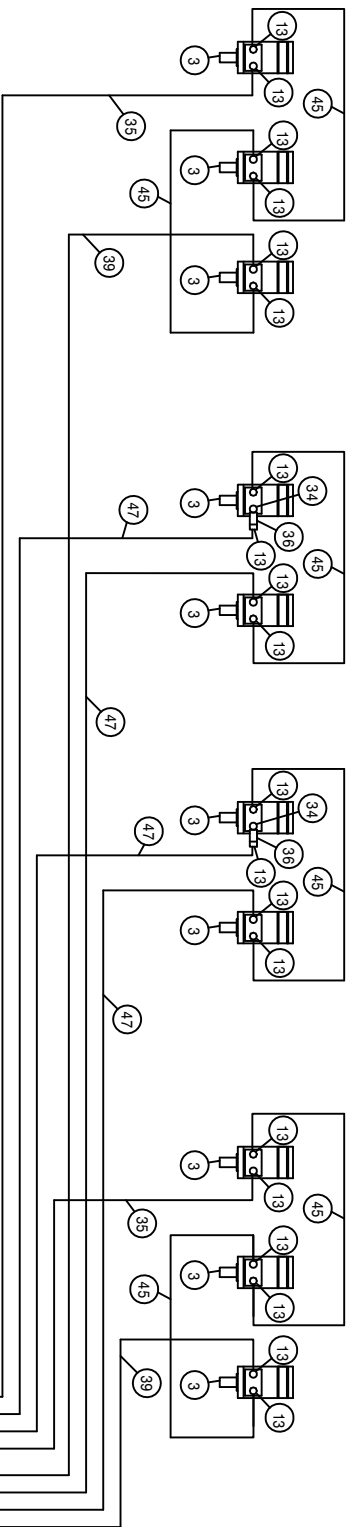

NOTE: * ITEMS 8, 11 & 43 ARE USED WITH THE CUMMINS ENGINE OPTION.
 ** ITEMS 8, 38 & 44 ARE USED WITH THE GMC ENGINE OPTION.

204 10R QUAD 4L HYD SCHEM 2004
REFERENCE DRAWING NO. 498798

DET.	QTY	PART NO.	DESCRIPTION	DET.	QTY	PART NO.	DESCRIPTION
1	1	610613	ELECT HYD STACT VLV, 4 SECT	30	4	618469	3/4MJIC-1 1/16MOR ADPTR
2	2	605615	HYD FILTER, INLINE 25M 9/16FOR	31	1	618618	9/16MJIC-90-9/16FJIC SWIV LBO
3	10	610547	HYD MOTOR 4.5CI 1IN SHFT	32	1	618178	1 5/16MJIC-90-1 5/16MOR LBO
4	1	618668	9/16FJIC SWIV-9/16MOR ADPTR	33	2	618115	9/16MJIC-90-3/4MOR LBO
5	1	606034	MTR CONTROL ELECT VLV	34	2	618586	7/8MOR UNION
*6	1	614633	HYD MANIF 8200 86	35	2	614384	08CIT-08FJX-08FJX-237
*7	1	605601	PARKER FILTER ASSY, 10M, 1.25NPT	36	2	607522	FLOW REGULATOR, 8GPM VONBERG
8	1	614350	16CZAT-16FJX-16FJX-55 H/A	37	1	618444	9/16MOR RUN TEE-9/16MJIC
9	1	618310	9/16MJIC-7/8MOR ADPTR	38	1	614719	HYD TUBE ASSY, AUX 204 GMC 96
10	4	621506	LIFT CYL ASSY 1M, DETASSELER	39	2	614387	08CIT-08FJX-08FJX-267
11	1	614703	HYD TUBE ASSY, 200 MAIN 92	*40	1	505209	BLK PIPE NIPPLE 1.00NPT-6.00
12	1	618692	3/4FJIC SWIV-9/16MOR ADPTR	*41	1	614627	06CIT-06FJX-06FJX-45
13	20	618327	3/4MJIC-7/8MOR ADPTR	*42	1	714561	1.00NPT-1.25 HOSE BARB
*14	1	618577	1 5/16MJIC UNION	43	1	601437	HOSE, 1 1/4 X 40 1FBR-1SPI
15	1	618440	9/16MJIC-90-9/16MOR EX LG LBO	44	1	601440	HOSE, 1 1/4 X 25 1FBR-1SPI
16	1	618170	3/4MOR-9/16FOR ADPTR	45	6	616025	08CIT-08FJX-08FJX-50
17	8	618119	9/16MJIC-90-9/16MOR LBO	46	2	614098	04CIT-06FJX-06FJX-201
*18	2	715660	HOSE BARB 1 1/4NPT X 1 1/4	47	4	614689	08CIT-08FJX-08FJX-120
19	1	615621	06CIT-06FJX-06FJX-24 H/A	*48	1	601378	HOSE, 1 1/4 X 156 1FBR-1SPI
*20	1	618587	1 5/16FJIC SWIV-1MNP	49	2	611202	04CIT-06FJX-06FJX-136
21	1	618600	9/16MJIC-90-7/8MOR LBO	50	2	614077	04CIT-06FJX-06FJX-88
*22	2	506410	BLK PIPE ST EL 90DEG 1.25NPT	51	2	615727	04CIT-06FJX-06FJX-75
*23	1	505300	BLK PIPE EL 90DEG 1.00NPT	52	2	621520	BOOM HINGE FOLD CYL ASSY
*24	4	611145	3/4MJIC-90-1/2MNP LBO	53	4	614747	.025 ELBOW ASSY, 9/16MOR 90D
25	2	618590	3/4MJIC-45-3/4FJIC SWIV LBO	54	1	606090	BRAND HYD VALVE, 2-SECT SER 36
*26	1	503700	PIPE PLUG .50NPT SQ HD	55	1	618126	9/16MJIC-9/16MOR ADPTR
27	1	618531	9/16FJIC CAP NUT	56	1	618183	3/4MJIC-90-7/8MOR LBO
*28	1	618532	3/4FJIC CAP NUT	57	2	618709	9/16MJIC-90-3/4MOR EX LG LBO
29	1	618186	1 5/16MJIC-1 5/16MOR ADPTR				

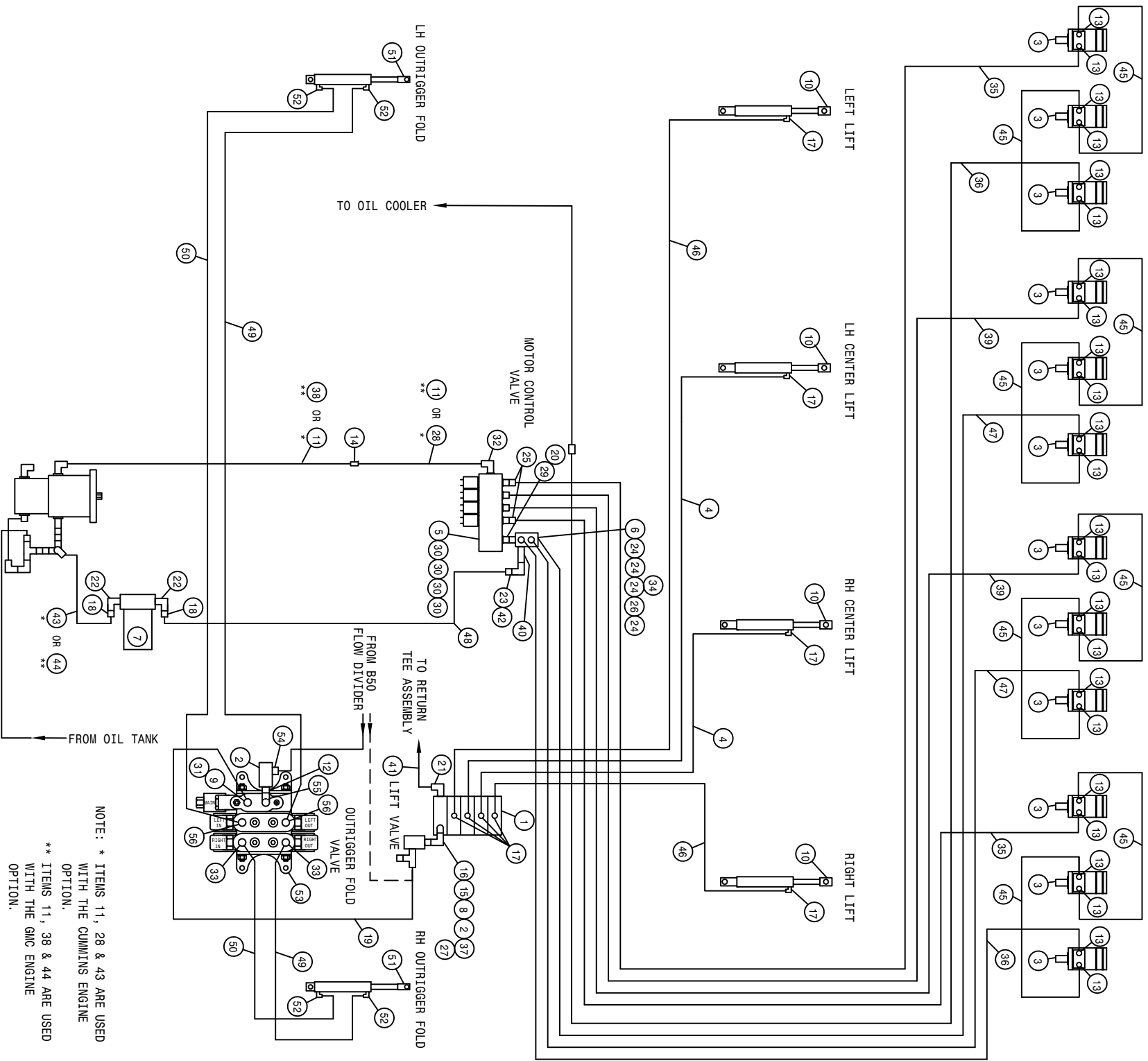

204 12R QUAD 4L LS HYD SCHEM 2004
REFERENCE DRAWING NO. 498799

DET.	QTY	PART NO.	DESCRIPTION	DET.	QTY	PART NO.	DESCRIPTION
1	1	610613	ELECT HYD STACT VLV, 4 SECT	29	1	618186	1 5/16MJIC-1 5/16MOR ADPTR
2	2	605615	HYD FILTER, INLINE 25M 9/16FOR	30	4	618469	3/4MJIC-1 1/16MOR ADPTR
3	12	610547	HYD MOTOR 4.5CI 1IN SHFT	31	1	618618	9/16MJIC-90-9/16FJIC SWIV LBO
4	2	611202	04C1T-06FJX-06FJX-136	32	1	618178	1 5/16MJIC-90-1 5/16MOR LBO
5	1	606034	MTR CONTROL ELECT VLV	33	2	618115	9/16MJIC-90-3/4MOR LBO
* 6	1	614633	HYD MANIF 8200 86	*34	1	618532	3/4FJIC CAP NUT
* 7	1	605601	PARKER FILTER ASSY, 10M, 1.25NPT	35	2	614384	08C1T-08FJX-08FJX-237
8	1	618668	9/16FJIC SWIV-9/16MOR ADPTR	36	2	614387	08C1T-08FJX-08FJX-267
9	1	618310	9/16MJIC-7/8MOR ADPTR	37	1	618444	9/16MOR RUN TEE-9/16MJIC
10	4	621506	LIFT CYL ASSY 1W, DETASSELER	38	1	614719	HYD TUBE ASSY, AUX 204 GMC 96
11	1	614350	16C2AT-16FJX-16FJX-55	39	2	614375	08C1T-08FJX-08FJX-177
12	1	618692	3/4FJIC SWIV-9/16MOR ADPTR	*40	1	505209	BLK PIPE NIPPLE 1.00NPT-6.00
13	24	618327	3/4MJIC-7/8MOR ADPTR	*41	1	614627	06C1T-06FJX-06FJX-45
*14	1	618577	1 5/16MJIC UNION	*42	1	714561	1.00NPT-1.25 HOSE BARB
15	1	618440	9/16MJIC-90-9/16MOR EX LG LBO	43	1	601437	HOSE, 1 1/4 X 40 1FBR-1SPI
16	1	618170	3/4MOR-9/16FOR ADPTR	44	1	601440	HOSE, 1 1/4 X 25 1FBR-1SPI
17	8	618119	9/16MJIC-90-9/16MOR LBO	45	8	616025	08C1T-08FJX-08FJX-50
*18	2	715660	HOSE BARB 1 1/4NPT X 1 1/4	46	2	614098	04C1T-06FJX-06FJX-201
19	1	615621	06C1T-06FJX-06FJX-24	47	2	614378	08C1T-08FJX-08FJX-207
*20	1	618587	1 5/16FJIC SWIV-1MNPT	H/A	1	601378	HOSE, 1 1/4 X 156 1FBR-1SPI
21	1	618600	9/16MJIC-90-7/8MOR LBO	49	2	614077	04C1T-06FJX-06FJX-88
*22	2	506410	BLK PIPE ST EL 90DEG 1.25NPT	50	2	615727	04C1T-06FJX-06FJX-75
*23	1	505300	BLK PIPE EL 90DEG 1.00NPT	51	2	621520	BOOM HINGE FOLD CYL ASSY
*24	4	611145	3/4MJIC-90-1/2MNPT LBO	52	4	614747	.025 ELBOW ASSY, 9/16MOR 90D
25	2	618590	3/4MJIC-45-3/4FJIC SWIV LBO	53	1	606090	BRAND HYD VALVE, 2-SECT SER 36
*26	1	503700	PIPE PLUG .50NPT SQ HD	54	1	618126	9/16MJIC-9/16MOR ADPTR
27	1	618531	9/16FJIC CAP NUT	55	1	618183	3/4MJIC-90-7/8MOR LBO
28	1	614703	HYD TUBE ASSY, 200 MAIN	56	2	618709	9/16MJIC-90-3/4MOR EX LG LBO

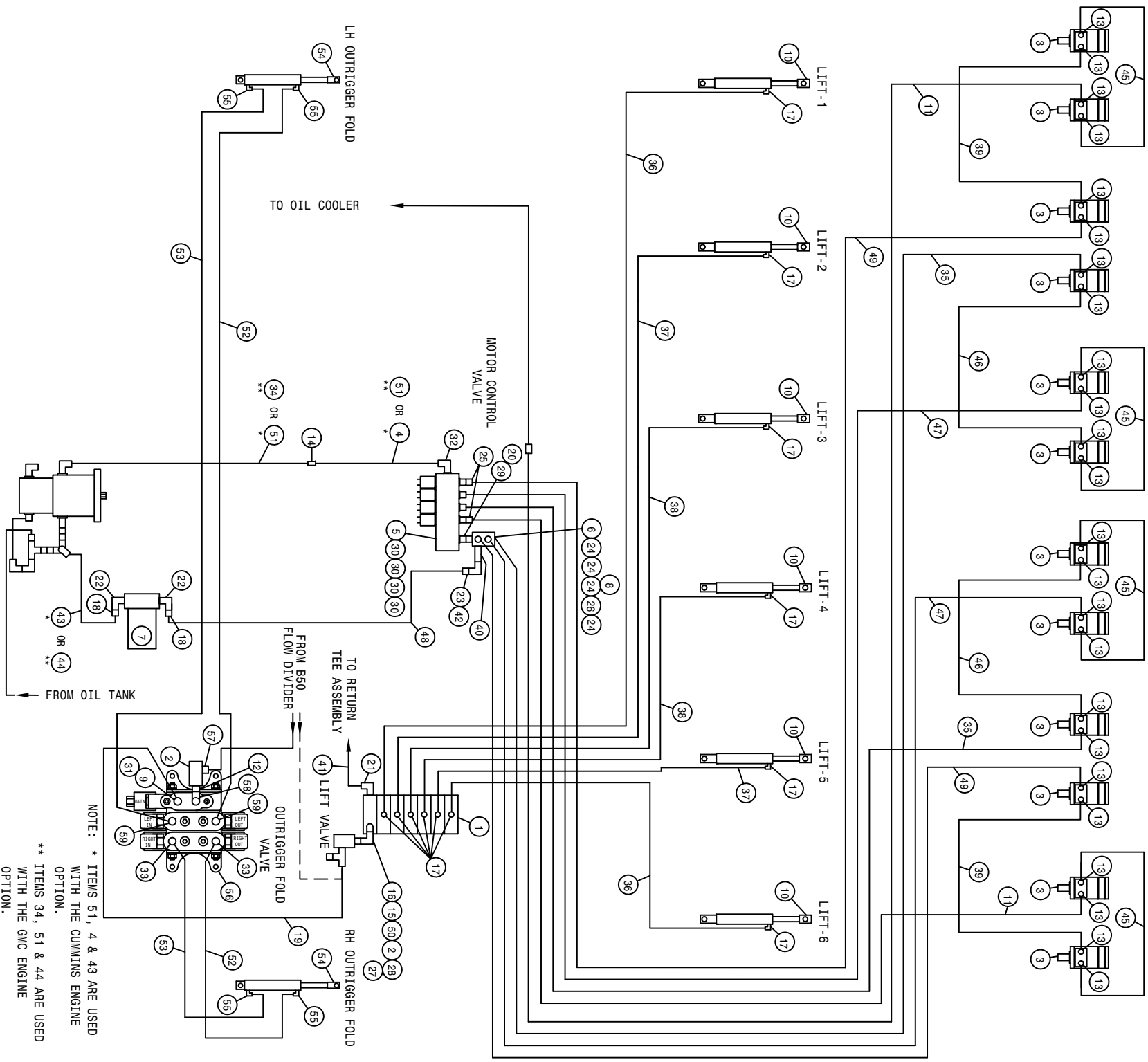

NOTE: * ITEMS 51, 4 & 43 ARE USED WITH THE CUMMINS ENGINE OPTION.
 ** ITEMS 34, 51 & 44 ARE USED WITH THE GMC ENGINE OPTION.

204 12R QUAD 6L LS HYD SCHEM 2004
REFERENCE DRAWING NO. 498800

DET.	QTY	PART NO.	DESCRIPTION	DET.	QTY	PART NO.	DESCRIPTION
1	1	610615	ELECT HYD STACT VLV, 6 SECT	31	1	618618	9/16MJIC-90-9/16FJIC SWIV LBO
2	2	605615	HYD FILTER, INLINE 25M 9/16FOR	32	1	618178	1 5/16MJIC-90-1 5/16MOR LBO
3	12	610547	HYD MOTOR 4.5CI 1IN SHFT	33	2	618115	9/16MJIC-90-3/4MOR LBO
* 4	1	614703	HYD TUBE ASSY, 200 MAIN	34	1	614719	HYD TUBE ASSY, AUX 204 GMC 96
5	1	606034	MTR CONTROL ELECT VLV	35	2	614578	08C1T-08FJX-08FJX-207
* 6	1	614633	HYD MANIF 8200 86	36	2	614577	04C1T-06FJX-06FJX-258
* 7	1	605601	PARKER FILTER ASSY, 10M, 1.25NPT	37	2	611246	04C1T-06FJX-06FJX-174
* 8	1	618532	3/4FJIC CAP NUT	38	2	614101	04C1T-06FJX-06FJX-133
9	1	618310	9/16MJIC-7/8MOR ADPTR	39	2	614690	08C1T-08FJX-08FJX-192
10	6	621506	LIFT CYL ASSY 1M, DETASSELER	*40	1	505209	BLK PIPE NIPPLE 1.00NPT-6.00
11	2	614387	08C1T-08FJX-08FJX-267	*41	1	614627	06C1T-06FJX-06FJX-45
12	1	618692	3/4FJIC SWIV-9/16MOR ADPTR	*42	1	714561	1.00NPT-1.25 HOSE BARB
13	24	618327	3/4MJIC-7/8MOR ADPTR	43	1	601437	HOSE, 1 1/4 X 40 1FBR-1SPI
*14	1	618577	1 5/16MJIC UNION	44	1	601440	HOSE, 1 1/4 X 25 1FBR-1SPI
15	1	618440	9/16MJIC-90-9/16MOR EX LG LBO	45	4	616025	08C1T-08FJX-08FJX-50
16	1	618170	3/4MOR-9/16FOR ADPTR	46	2	614384	08C1T-08FJX-08FJX-237
17	12	618119	9/16MJIC-90-9/16MOR LBO	47	2	614689	08C1T-08FJX-08FJX-120
*18	2	715660	HOSE BARB 1 1/4NPT X 1 1/4	*48	1	601378	HOSE, 1 1/4 X 156 1FBR-1SPI
19	1	615621	06C1T-06FJX-06FJX-24	49	2	614691	08C1T-08FJX-08FJX-220
*20	1	618587	1 5/16FJIC SWIV-1MNPT	50	1	618668	9/16FJIC SWIV-9/16MOR ADPTR
21	1	618600	9/16MJIC-90-7/8MOR LBO	51	1	614350	16C2AT-16FJX-16FJX-55
*22	2	506410	BLK PIPE ST EL 90DEG 1.25NPT	52	2	614077	04C1T-06FJX-06FJX-88
*23	1	505300	BLK PIPE EL 90DEG 1.00NPT	53	2	615727	04C1T-06FJX-06FJX-75
*24	4	611145	3/4MJIC-90-1/2MNPT LBO	54	2	621520	BOOM HINGE FOLD CYL ASSY
25	2	618590	3/4MJIC-45-3/4FJIC SWIV LBO	55	4	614747	.025 ELBOW ASSY, 9/16MOR 90D
*26	1	503700	PIPE PLUG .50NPT SQ HD	56	1	606090	BRAND HYD VALVE, 2-SECT SER 36
27	1	618531	9/16FJIC CAP NUT	57	1	618126	9/16MJIC-9/16MOR ADPTR
28	1	618444	9/16MOR RUN TEE-9/16MJIC	58	1	618183	3/4MJIC-90-7/8MOR LBO
29	1	618186	1 5/16MJIC-1 5/16MOR ADPTR	59	2	618709	9/16MJIC-90-3/4MOR EX LG LBO
30	4	618469	3/4MJIC-1 1/16MOR ADPTR				

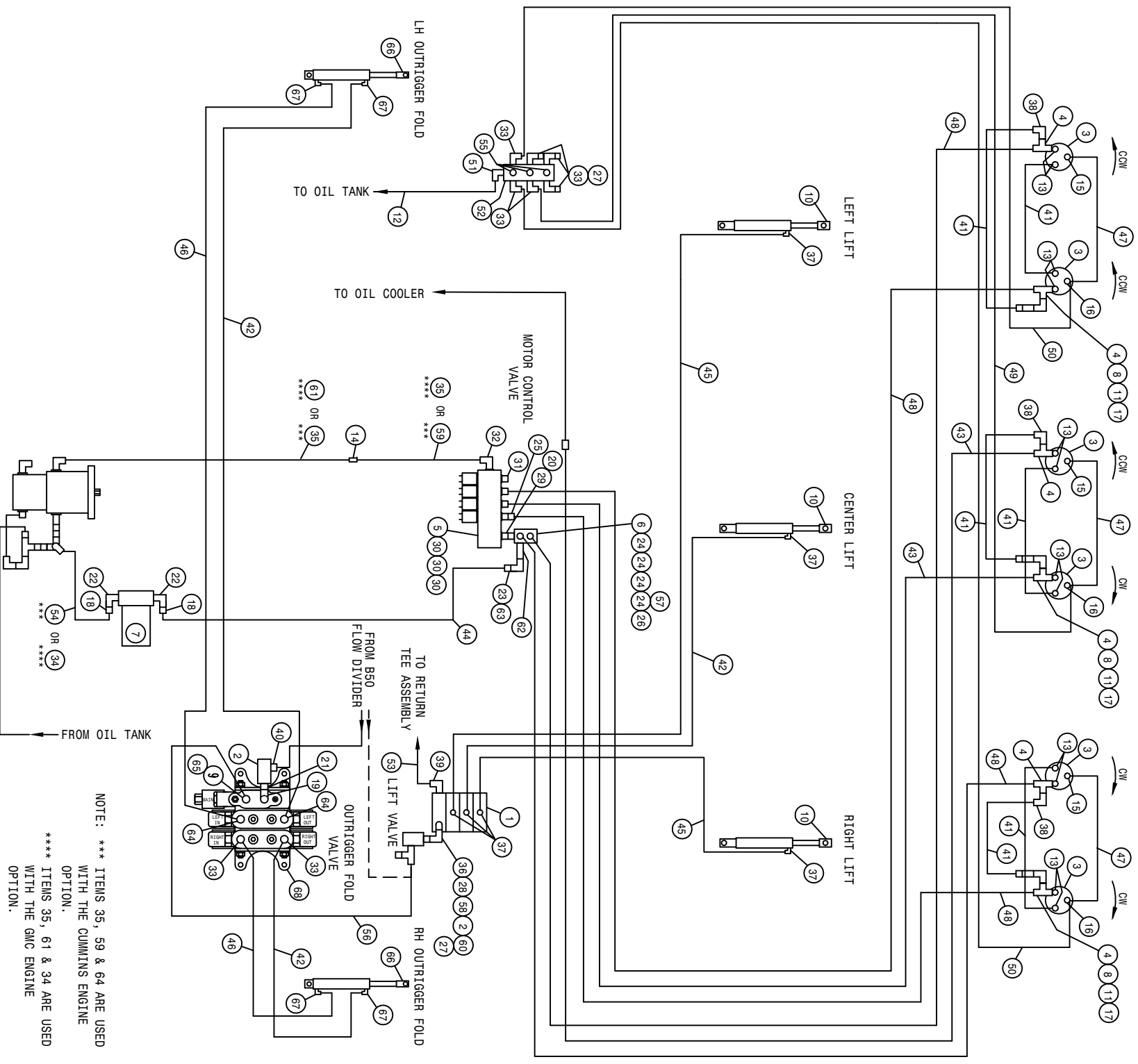

204 6R CUTTER 3L LS HYD SCHEM 2004
REFERENCE DRAWING NO. 498801

DET.	QTY	PART NO.	DESCRIPTION	DET.	QTY	PART NO.	DESCRIPTION
1	1	610532	ELECT HYD STACK VLV, 3 SECT	35	1	614350	16C2AT-16FJX-16FJX-55
2	2	605615	HYD FILTER, INLINE 25M 9/16FOR	36	1	618170	3/4MOR-9/16FOR ADPTR
3	6	610755	BARNES HYD MOTOR, D-SERIES 01	37	6	618119	9/16MJIC-90-9/16MOR LBO
4	6	618451	3/4FJIC SW RUN TEE-3/4MJIC	38	3	618609	3/4MJIC-90-3/4FJIC SWIV LBO
5	1	606034	MTR CONTROL ELECT VLV	39	1	618600	9/16MJIC-90-7/8MOR LBO
*6	1	614633	HYD MANIF 8200 86	40	1	618126	9/16MJIC-9/16MOR ADPTR
*7	1	605601	PARKER FILTER ASSY, 10M, 1.25NPT	41	6	614368	08C1T-08FJX-08FJX-60
8	3	618620	3/4FJX-90-1/2MNPT ADPTR	42	3	614077	04C1T-06FJX-06FJX-88
9	1	618310	9/16MJIC-7/8MOR ADPTR	43	2	614688	08C1T-08FJX-08FJX-108
10	3	621506	LIFT CYL ASSY 1W,DETAASSELLER	*44	1	601378	HOSE, 1 1/4 X 156 1FBR-1SPI
11	3	690338	LINE CHECK VALVE HYD .50NPT	45	2	614101	04C1T-06FJX-06FJX-133
12	1	601555	HOSE, 3/4 X 150 1FBR-1SPI	46	2	615727	04C1T-06FJX-06FJX-75
13	12	611125	3/4MJIC-3/4MOR ADPTR	47	3	611206	04C1T-06FJX-06FJX-66
*14	1	618577	1 5/16MJIC UNION	48	4	614690	08C1T-08FJX-08FJX-192
15	3	618530	9/16MJIC-1/8MNPT ADPTR	49	1	614152	04C1T-06FJX-06FJX-114
16	3	618546	1/8MNPT RUN TEE-9/16MJIC	50	2	611210	04C1T-06FJX-06FJX-156
17	3	611147	3/4MJIC-1/2MNPT ADPTR	51	1	618118	3/4 HOSE BARB-90-1 1/16MOR
*18	2	715660	HOSE BARB 1 1/4NPT X 1 1/4	52	1	606021	HYD RETURN MANIF, 3/4FOR, 9-PORT
19	1	618183	3/4MJIC-90-7/8MOR LBO	*53	1	614627	06C1T-06FJX-06FJX-45
*20	1	618587	1 5/16FJIC SWIV-1MNPT	54	1	601437	HOSE, 1 1/4 X 40 1FBR-1SPI
21	1	618692	3/4FJIC SWIV-9/16MOR ADPTR	55	3	611159	3/4MOR PLUG
*22	2	506410	BLK PIPE ST EL 90DEG 1.25NPT	56	1	615621	06C1T-06FJX-06FJX-24
*23	1	505300	BLK PIPE EL 90DEG 1.00NPT	*57	1	618532	3/4FJIC CAP NUT
*24	4	611145	3/4MJIC-90-1/2MNPT LBO	58	1	618668	9/16FJIC SWIV-9/16MOR ADPTR
25	1	618590	3/4MJIC-45-3/4FJIC SWIV LBO	59	1	614703	HYD TUBE ASSY, 200 MAIN
*26	1	503700	PIPE PLUG .50NPT SQ HD	60	1	618444	9/16MOR RUN TEE-9/16MJIC
27	4	618531	9/16FJIC CAP NUT	61	1	614719	HYD TUBE ASSY, AUX 204 GWC 96
28	1	618440	9/16MJIC-90-9/16MOR EX LG LBO	*62	1	505209	BLK PIPE NIPPLE 1.00NPT-6.00
29	1	618186	1 5/16MJIC-1 5/16MOR ADPTR	*63	1	714561	1.00NPT-1.25 HOSE BARB
30	3	618469	3/4MJIC-1 1/16MOR ADPTR	64	2	618709	9/16MJIC-90-3/4MOR EX LG LBO
31	1	610186	1 1/16MOR PLUG	65	1	618618	9/16MJIC-90-9/16FJIC SWIV LBO
32	1	618178	1 5/16MJIC-90-1 5/16MOR LBO	66	2	621520	BOOM HINGE FOLD CYL ASSY
33	8	618115	9/16MJIC-90-3/4MOR LBO	67	4	614747	.025 ELBOW ASSY, 9/16MOR 90D
34	1	601440	HOSE, 1 1/4 X 25 1FBR-1SPI	68	1	606090	BRAND HYD VALVE, 2-SECT SER 36

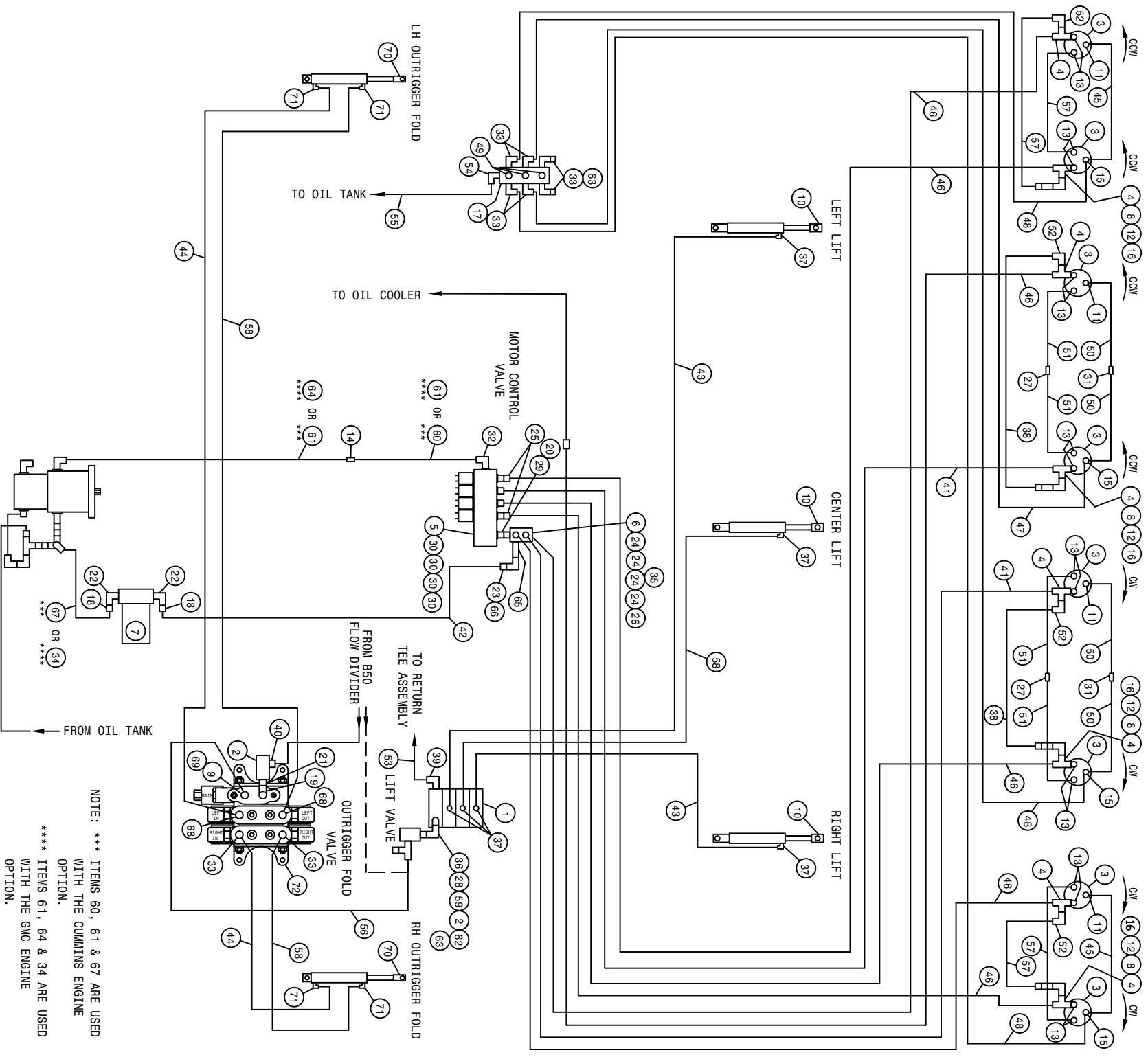

204 8R CUTTER 3L LS HYD SCHEM 2004
REFERENCE DRAWING NO. 498802

DET.	QTY	PART NO.	DESCRIPTION	DET.	QTY	PART NO.	DESCRIPTION
1	1	610532	ELECT HYD STACK VLV, 3 SECT	37	618119	9/16MJIC-90-9/16MOR LBO	
2	2	605615	HYD FILTER, INLINE 25M 9/16FOR	38	614384	08C1T-08FJX-08FJX-237	H/A
3	8	610755	BARNES HYD MOTOR, D-SERIES 01	39	618600	9/16MJIC-90-7/8MOR LBO	
4	8	618451	3/4FJIC SW RUN TEE-3/4MJIC	40	618126	9/16MJIC-9/16MOR ADPTR	
5	1	606034	MTR CONTROL ELECT VLV	41	614688	08C1T-08FJX-08FJX-108	H/A
*6	1	614633	HYD MANIF 8200 86	*42	601378	HOSE, 1 1/4 X 156 1FBR-1SPI	
*7	1	605601	PARKER FILTER ASSY, 10M, 1.25NPT	43	611246	04C1T-06FJX-06FJX-174	H/A
8	4	618620	3/4FJX-90-1/2MNPT ADPTR	44	615727	04C1T-06FJX-06FJX-75	H/A
9	1	618310	9/16MJIC-7/8MOR ADPTR	45	611206	04C1T-06FJX-06FJX-66	H/A
10	3	621506	LIFT CYL ASSY 1M, DETASSELER	46	614691	08C1T-08FJX-08FJX-220	H/A
11	4	618530	9/16MJIC-1/8MNPT ADPTR	47	614152	04C1T-06FJX-06FJX-114	H/A
12	4	690338	LINE CHECK VALVE HYD, 50NPT	48	614154	04C1T-06FJX-06FJX-221	H/A
13	16	611125	3/4MJIC-3/4MOR ADPTR	49	611159	3/4MOR PLUG	
*14	1	618577	1 5/16MJIC UNION	50	614101	04C1T-06FJX-06FJX-133	H/A
15	4	618546	1/8MNPT RUN TEE-9/16MJIC	51	614425	08C1T-08FJX-08FJX-132	H/A
16	4	611147	3/4MJIC-1/2MNPT ADPTR	52	618609	3/4MJIC-90-3/4FJIC SWIV LBO	
17	1	606021	HYD RETURN MANIF, 3/4FOR, 9-PORT	*53	614627	06C1T-06FJX-06FJX-45	H/A
*18	2	715660	HOSE BARB 1 1/4NPT X 1 1/4	54	618118	3/4 HOSE BARB-90-1 1/16MOR	
19	1	618183	3/4MJIC-90-7/8MOR LBO	55	601555	HOSE, 3/4 X 150 1FBR-1SPI	
*20	1	618587	1 5/16FJIC SWIV-1MNPT	56	615621	06C1T-06FJX-06FJX-24	H/A
21	1	618692	3/4FJIC SWIV-9/16MOR ADPTR	57	614368	08C1T-08FJX-08FJX-60	H/A
*22	2	506410	BLK PIPE ST EL 90DEG 1.25NPT	58	614077	04C1T-06FJX-06FJX-88	H/A
*23	1	505300	BLK PIPE EL 90DEG 1.00NPT	59	618668	9/16FJIC SWIV-9/16MOR ADPTR	
*24	4	611145	3/4MJIC-90-1/2MNPT LBO	60	614703	HYD TUBE ASSY, 200 MAIN	92
25	2	618590	3/4MJIC-45-3/4FJIC SWIV LBO	61	614350	16C2AT-16FJX-16FJX-55	H/A
*26	1	503700	PIPE PLUG .50NPT SQ HD	62	618444	9/16MOR RUN TEE-9/16MJIC	
27	2	618314	3/4MJIC UNION	63	618531	9/16FJIC CAP NUT	
28	1	618440	9/16MJIC-90-9/16MOR EX LG LBO	64	614719	HYD TUBE ASSY, AUX 204 GMC 96	
29	1	618186	1 5/16MJIC-1 5/16MOR ADPTR	*65	505209	BLK PIPE NIPPLE 1.00NPT-6.00	
30	4	618469	3/4MJIC-1 1/16MOR ADPTR	*66	714561	1.00NPT-1.25 HOSE BARB	
31	2	619010	9/16MJIC UNION	67	601437	HOSE, 1 1/4 X 40 1FBR-1SPI	
32	1	618178	1 5/16MJIC-90-1 5/16MOR LBO	68	618709	9/16MJIC-90-3/4MOR EX LG LBO	
33	8	618115	9/16MJIC-90-3/4MOR LBO	69	618618	9/16MJIC-90-9/16FJIC SWIV LBO	
34	1	601440	HOSE, 1 1/4 X 25 1FBR-1SPI	70	621520	BOOM HINGE FOLD CYL ASSY	
*35	1	618532	3/4FJIC CAP NUT	71	614747	.025 ELBOW ASSY, 9/16MOR 90D	
36	1	618170	3/4MOR-9/16FOR ADPTR	72	606090	BRAND HYD VALVE, 2-SECT SER 36	

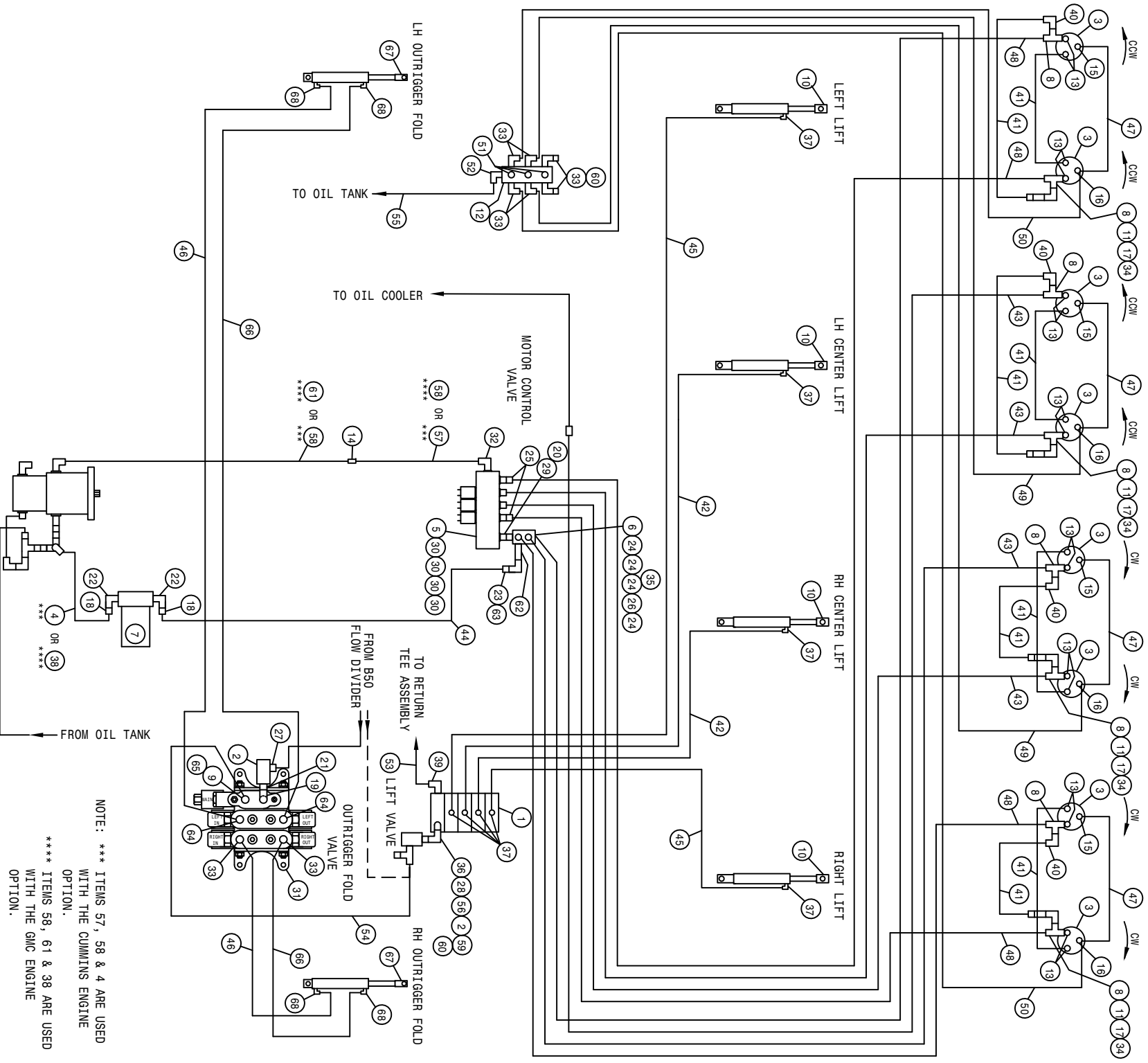

NOTE: *** ITEMS 57, 58 & 4 ARE USED WITH THE CUMMINS ENGINE OPTION.
 **** ITEMS 59, 61 & 38 ARE USED WITH THE GMC ENGINE OPTION.

204 8R CUTTER 4L LS HYD SCHEM 2004
REFERENCE DRAWING NO. 498803

DET.	QTY	PART NO.	DESCRIPTION	DET.	QTY	PART NO.	DESCRIPTION
1	1	610613	ELECT HYD STACT VLV, 4 SECT	*35	1	618532	3/4FJIC CAP NUT
2	2	605615	HYD FILTER, INLINE 25M 9/16FOR	36	1	618170	3/4MOR-9/16FOR ADPTR
3	8	610755	BARNES HYD MOTOR, D-SERIES 01	37	8	618119	9/16MJIC-90-9/16MOR LBO
4	1	601437	HOSE, 1 1/4 X 40 1FBR-1SPI	38	1	601440	HOSE, 1 1/4 X 25 1FBR-1SPI
5	1	606034	MTR CONTROL ELECT VLV	39	1	618600	9/16MJIC-90-7/8MOR LBO
*6	1	614633	HYD MANIF 8200 86	40	4	618609	3/4MJIC-90-3/4FJIC SWIV LBO
*7	1	605601	PARKER FILTER ASSY, 10M, 1.25NPT	41	8	614368	08CIT-08FJX-08FJX-60
8	8	618451	3/4FJIC SW RUN TEE-3/4MJIC	42	2	614101	04CIT-06FJX-06FJX-133
9	1	618310	9/16MJIC-7/8MOR ADPTR	43	4	614689	08CIT-08FJX-08FJX-120
10	4	621506	LIFT CYL ASSY 1M, DETASSELER	*44	1	601378	HOSE, 1 1/4 X 156 1FBR-1SPI
11	4	606021	3/4FJX-90-1/2MNPT ADPTR	45	2	611246	04CIT-06FJX-06FJX-174
12	1	606021	HYD RETURN MANIF, 3/4FOR, 9-PORT	46	2	615727	04CIT-06FJX-06FJX-75
13	16	611125	3/4MJIC-3/4MOR ADPTR	47	4	611206	04CIT-06FJX-06FJX-66
*14	1	618577	1 5/16MJIC UNION	48	4	614691	08CIT-08FJX-08FJX-220
15	4	618530	9/16MJIC-1/8MNPT ADPTR	49	2	611212	04CIT-06FJX-06FJX-164
16	4	618546	1/8MNPT RUN TEE-9/16MJIC	50	2	614154	04CIT-06FJX-06FJX-221
17	4	690338	LINE CHECK VALVE HYD .50NPT	51	3	611159	3/4MOR PLUG
*18	2	715660	HOSE BARB 1 1/4NPT X 1 1/4	52	1	618118	3/4 HOSE BARB-90-1 1/16MOR
19	1	618183	3/4MJIC-90-7/8MOR LBO	*53	1	614627	06CIT-06FJX-06FJX-45
*20	1	618587	1 5/16FJIC SWIV-1MNPT	54	1	615621	06CIT-06FJX-06FJX-24
*22	2	506410	BLK PIPE ST EL 90DEG 1.25NPT	55	1	601555	HOSE, 3/4 X 150 1FBR-1SPI
*23	1	505300	BLK PIPE EL 90DEG 1.00NPT	56	1	618668	9/16FJIC SWIV-9/16MOR ADPTR
*24	4	611145	3/4MJIC-90-1/2MNPT LBO	57	1	614703	HYD TUBE ASSY, 200 MAIN
25	2	618590	3/4MJIC-45-3/4FJIC SWIV LBO	58	1	614350	16C2AT-16FJX-16FJX-55
*26	1	503700	PIPE PLUG .50NPT SQ HD	59	1	618444	9/16MOR RUN TEE-9/16MJIC
27	1	618126	9/16MJIC-9/16MOR ADPTR	60	3	618531	9/16FJIC CAP NUT
28	1	618440	9/16MJIC-90-9/16MOR EX LG LBO	61	1	614719	HYD TUBE ASSY, AUX 204 GMC 96
29	1	618186	1 5/16MJIC-1 5/16MOR ADPTR	*62	1	505209	BLK PIPE NIPPLE 1.00NPT-6.00
30	4	618469	3/4MJIC-1 1/16MOR ADPTR	*63	1	714561	1.00NPT-1.25 HOSE BARB
31	1	606090	BRAND HYD VALVE, 2-SECT SER 36	64	2	618709	9/16MJIC-90-3/4MOR EX LG LBO
32	1	618178	1 5/16MJIC-90-1 5/16MOR LBO	65	1	618618	9/16MJIC-90-9/16FJIC SWIV LBO
33	8	618115	9/16MJIC-90-3/4MOR LBO	66	2	614077	04CIT-06FJX-06FJX-88
34	4	611147	3/4MJIC-1/2MNPT ADPTR	67	2	621520	BOOM HINGE FOLD CYL ASSY
				68	4	614747	.025 ELBOW ASSY, 9/16MOR 90D

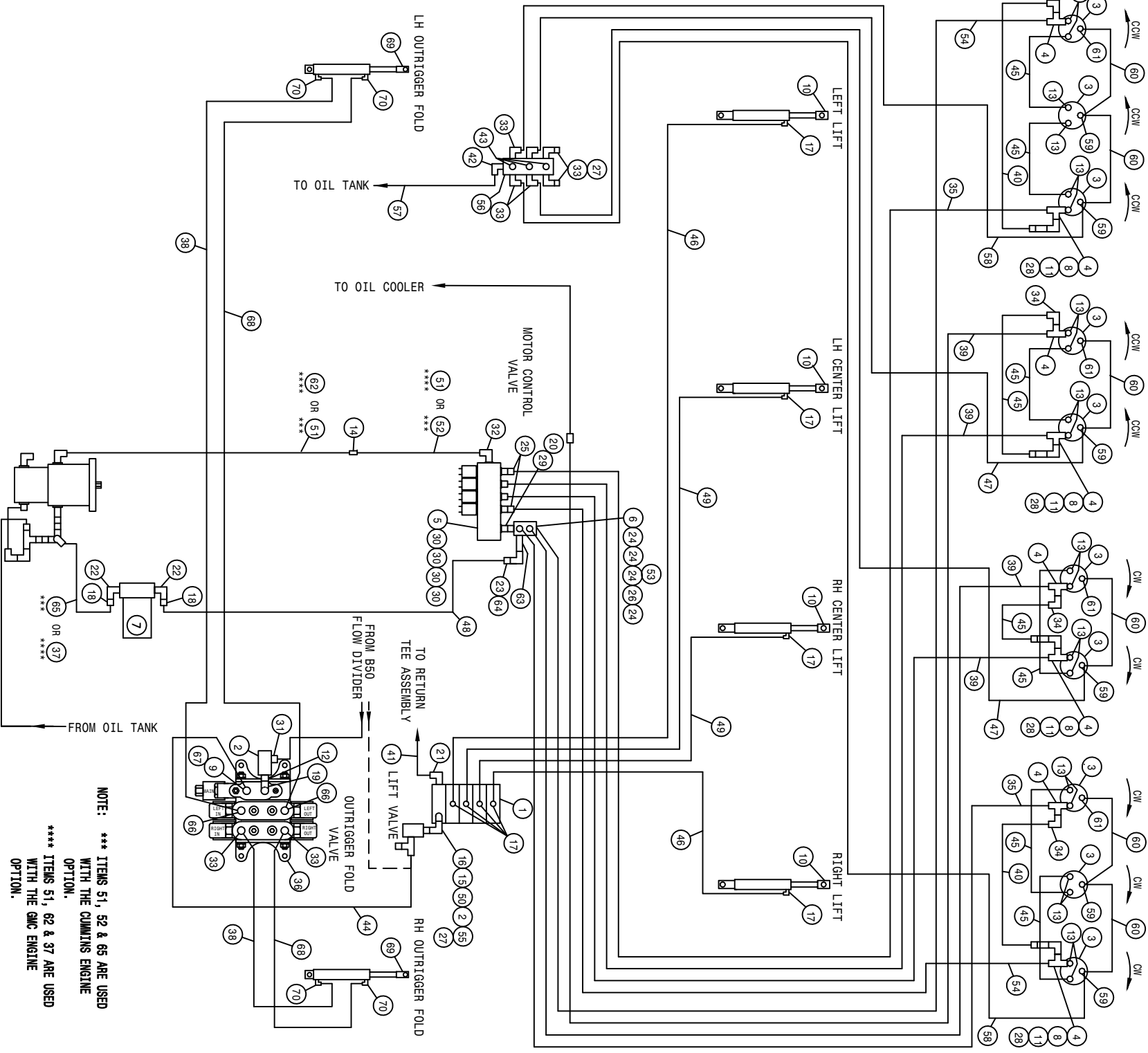

204 10R CUTR 4L LS HYD SCHEM 2004
 REFERENCE DRAWING NO. 498804

DET.	QTY	PART NO.	DESCRIPTION	DET.	QTY	PART NO.	DESCRIPTION
1	1	610613	ELECT HYD STACT VLV, 4 SECT	36	1	606090	BRAND HYD VALVE, 2-SECT SER 36
2	2	605615	HYD FILTER, INLINE 25M 9/16FOR	37	1	601440	HOSE, 1 1/4 X 25 1FBR-1SPI
3	10	610755	BARNES HYD MOTOR, D-SERIES 01	38	2	615727	04C1T-06FJX-06FJX-75
4	8	618451	3/4FJIC SW RUN TEE-3/4MJIC	39	4	614689	08C1T-08FJX-08FJX-120
5	1	606034	MTR CONTROL ELECT VLV	40	2	616057	08C1T-08FJX-08FJX-88
*6	1	614633	HYD MANIF 8200 86	*41	1	614627	06C1T-06FJX-06FJX-45
*7	1	605601	PARKER FILTER ASSY, 10M, 1.25NPT	42	1	618118	3/4 HOSE BARB-90-1 1/16MOR
8	4	618620	3/4FJX-90-1/2MNPT ADPTR	43	3	611159	3/4MOR PLUG
9	1	618310	9/16MJIC-7/8MOR ADPTR	44	1	615621	06C1T-06FJX-06FJX-24
10	4	621506	LIFT CYL ASSY 1W,DETASSELER	45	8	614368	08C1T-08FJX-08FJX-60
11	4	690338	LINE CHECK VALVE HYD .50NPT	46	2	614098	04C1T-06FJX-06FJX-201
12	1	618692	3/4FJIC SWIV-9/16MOR ADPTR	47	2	614076	04C1T-06FJX-06FJX-119
13	20	611125	3/4MJIC-3/4MOR ADPTR	*48	1	601378	HOSE, 1 1/4 X 156 1FBR-1SPI
*14	1	618577	1 5/16MJIC UNION	49	2	611202	04C1T-06FJX-06FJX-136
15	1	618440	9/16MJIC-90-9/16MOR EX LG LBO	50	1	618668	9/16FJIC SWIV-9/16MOR ADPTR
16	1	618170	3/4MOR-9/16FOR ADPTR	51	1	614350	16C2AT-16FJX-16FJX-55
17	8	618119	9/16MJIC-90-9/16MOR LBO	52	1	614703	HYD TUBE ASSY, 200 MAIN
*18	2	715660	HOSE BARB 1 1/4NPT X 1 1/4	*53	1	618532	3/4FJIC CAP NUT
19	1	618183	3/4MJIC-90-7/8MOR LBO	54	2	614387	08C1T-08FJX-08FJX-267
*20	1	618587	1 5/16FJIC SWIV-1MNPT	55	1	618444	9/16MOR RUN TEE-9/16MJIC
21	1	618600	9/16MJIC-90-7/8MOR LBO	56	1	606021	HYD RETURN MANIF, 3/4FOR, 9-POR
*22	2	506410	BLK PIPE ST EL 90DEG 1.25NPT	57	1	601555	HOSE, 3/4 X 150 1FBR-1SPI
*23	1	505300	BLK PIPE EL 90DEG 1.00NPT	58	2	614554	04C1T-06FJX-06FJX-240
*24	4	611145	3/4MJIC-90-1/2MNPT LBO	59	6	618546	1/8MNPT RUN TEE-9/16MJIC
25	2	618590	3/4MJIC-45-3/4FJIC SWIV LBO	60	6	611206	04C1T-06FJX-06FJX-66
*26	1	503700	PIPE PLUG .50NPT SQ HD	61	4	618530	9/16MJIC-1/8MNPT ADPTR
27	3	618531	9/16FJIC CAP NUT	62	1	614719	HYD TUBE ASSY, AUX 204 GMC 96
28	4	611147	3/4MJIC-1/2MNPT ADPTR	*63	1	505209	BLK PIPE NIPPLE 1.00NPT-6.00
29	1	618186	1 5/16MJIC-1 5/16MOR ADPTR	*64	1	714561	1.00NPT-1.25 HOSE BARB
30	4	618469	3/4MJIC-1 1/16MOR ADPTR	65	1	601437	HOSE, 1 1/4 X 40 1FBR-1SPI
31	1	618126	9/16MJIC-9/16MOR ADPTR	66	2	618709	9/16MJIC-90-3/4MOR EX LG LBO
32	1	618178	1 5/16MJIC-90-1 5/16MOR LBO	67	1	618618	9/16MJIC-90-9/16FJIC SWIV LBO
33	8	618115	9/16MJIC-90-3/4MOR LBO	68	2	614077	04C1T-06FJX-06FJX-88
34	4	618609	3/4MJIC-90-3/4FJIC SWIV LBO	69	2	621520	BOOM HINGE FOLD CYL ASSY
35	2	614384	08C1T-08FJX-08FJX-237	H/A	4	614747	.025 ELBOW ASSY, 9/16MOR 90D

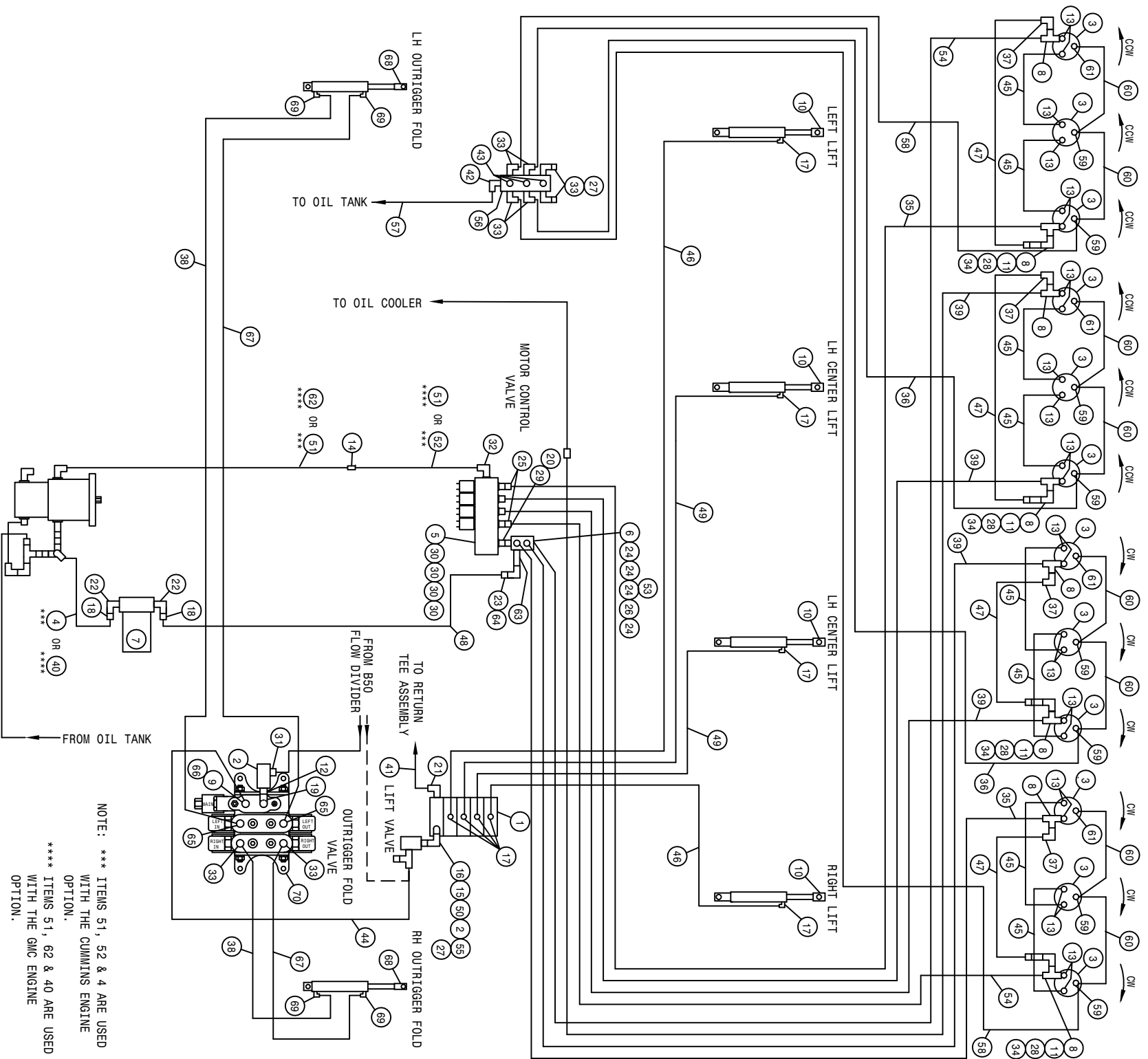

NOTE: **** ITEMS 51, 52 & 4 ARE USED WITH THE CUMMINS ENGINE
 ***** ITEMS 51, 62 & 40 ARE USED WITH THE GMC ENGINE OPTION.

204 12R CUTR 4L LS SCHEM 2004
REFERENCE DRAWING NO. 498805

DET.	QTY	PART NO.	DESCRIPTION	DET.	QTY	PART NO.	DESCRIPTION
1	1	610613	ELECT HYD STACT VLV, 4 SECT	36	2	614076	04C1T-06FJX-06FJX-119
2	2	605615	HYD FILTER, INLINE 25M 9/16FOR	37	4	618609	3/4MJIC-.90-3/4FJIC SWIV LBO
3	12	610755	BARNES HYD MOTOR, D-SERIES 01	38	2	615727	04C1T-06FJX-06FJX-75
4	1	601437	HOSE, 1 1/4 X 40 1FBR-1SPI	39	4	614375	08C1T-08FJX-08FJX-177
5	1	606034	MTR CONTROL ELECT VLV	40	1	601440	HOSE, 1 1/4 X 25 1FBR-1SPI
* 6	1	614633	HYD MANIF 8200 86	*41	1	614627	06C1T-06FJX-06FJX-45
* 7	1	605601	PARKER FILTER ASSY, 10M, 1.25NPT	42	1	618118	3/4 HOSE BARB-.90-1 1/16MOR
8	8	618451	3/4FJIC SW RUN TEE-3/4MJIC	43	3	611159	3/4MOR PLUG
9	1	618310	9/16MJIC-.7/8MOR ADPTR	44	1	615621	06C1T-06FJX-06FJX-24
10	4	621506	LIFT CYL ASSY 1M, DETASSELER	45	8	614368	08C1T-08FJX-08FJX-60
11	4	618620	3/4FJIC-.90-1/2MNPT ADPTR	46	2	614098	04C1T-06FJX-06FJX-201
12	4	618692	3/4FJIC SWIV-9/16MOR ADPTR	47	4	614689	08C1T-08FJX-08FJX-120
13	24	611125	3/4MJIC-3/4MOR ADPTR	*48	1	601378	HOSE, 1 1/4 X 156 1FBR-1SPI
*14	1	618577	1 5/16MJIC UNION	49	2	611202	04C1T-06FJX-06FJX-136
15	1	618440	9/16MJIC-.90-9/16MOR EX LG LBO	50	1	618668	9/16FJIC SWIV-9/16MOR ADPTR
16	1	618170	3/4MOR-9/16FOR ADPTR	51	1	614350	16C2AT-16FJX-16FJX-55
17	8	618119	9/16MJIC-.90-9/16MOR LBO	52	1	614703	HYD TUBE ASSY, 200 MAIN
*18	2	715660	HOSE BARB 1 1/4NPT X 1 1/4	*53	1	618532	3/4FJIC CAP NUT
19	1	618183	3/4MJIC-.90-7/8MOR LBO	54	2	614387	08C1T-08FJX-08FJX-267
*20	1	618587	1 5/16FJIC SWIV-.1MNPT	55	1	618444	9/16MOR RUN TEE-9/16MJIC
21	1	618600	9/16MJIC-.90-7/8MOR LBO	56	1	606021	HYD RETURN MANIF, 3/4FOR, 9-PORT
*22	2	506410	BLK PIPE ST EL 90DEG 1.25NPT	57	1	601555	HOSE, 3/4 X 150 1FBR-1SPI
*23	1	505300	BLK PIPE EL 90DEG 1.00NPT	58	2	614554	04C1T-06FJX-06FJX-240
*24	4	611145	3/4MJIC-.90-1/2MNPT LBO	59	8	618546	1/8MNPT RUN TEE-9/16MJIC
25	2	618590	3/4MJIC-.45-3/4FJIC SWIV LBO	60	8	611206	04C1T-06FJX-06FJX-66
*26	1	503700	PIPE PLUG .50NPT SQ HD	61	4	618530	9/16MJIC-1/8MNPT ADPTR
27	3	618531	9/16FJIC CAP NUT	62	1	614719	HYD TUBE ASSY, AUX 204 GMC 96
28	4	690338	LINE CHECK VALVE HYD .50NPT	*63	1	505209	BLK PIPE NIPPLE 1.00NPT-6.00
29	1	618186	1 5/16MJIC-1 5/16MOR ADPTR	*64	1	714561	1.00NPT-1.25 HOSE BARB
30	4	618469	3/4MJIC-1 1/16MOR ADPTR	65	2	618709	9/16MJIC-.90-3/4MOR EX LG LBO
31	1	618126	9/16MJIC-.9/16MOR ADPTR	66	1	618618	9/16MJIC-.90-9/16FJIC SWIV LBO
32	1	618178	1 5/16MJIC-.90-1 5/16MOR LBO	67	2	614077	04C1T-06FJX-06FJX-88
33	8	618115	9/16MJIC-.90-3/4MOR LBO	68	2	621520	BOOM HINGE FOLD CYL ASSY
34	4	611147	3/4MJIC-1/2MNPT ADPTR	69	4	614747	.025 ELBOW ASSY, 9/16MOR 90D
35	2	614384	08C1T-08FJX-08FJX-237	H/A	1	606090	BRAND HYD VALVE, 2-SECT SER 36

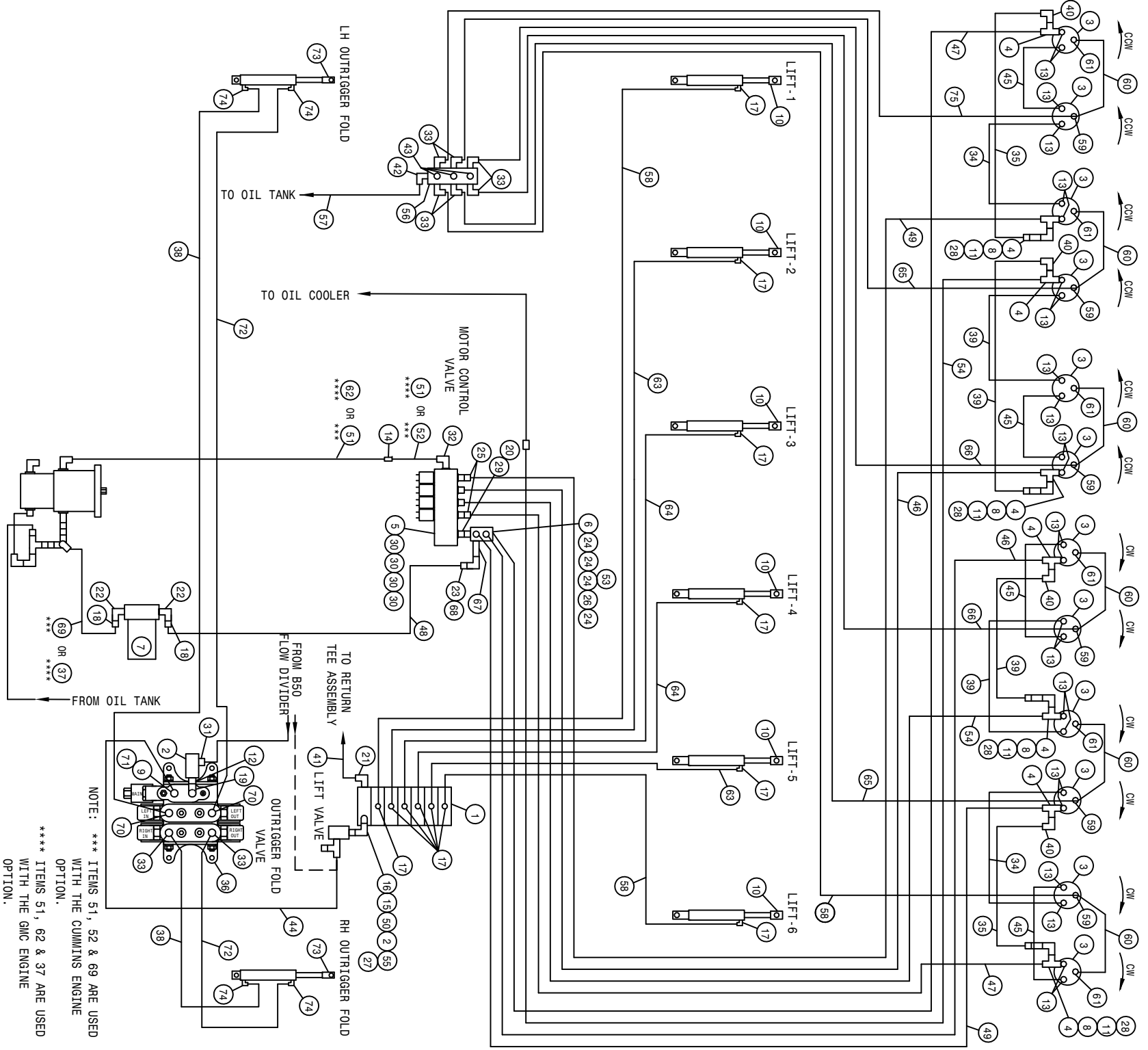

NOTE: *** ITEMS 51, 52 & 69 ARE USED WITH THE CUMMINS ENGINE OPTION.
 **** ITEMS 51, 62 & 37 ARE USED WITH THE GMC ENGINE OPTION.

204 12R CUTR 6L LS HYD SCHEM 2004
REFERENCE DRAWING NO. 498806

DET.	QTY	PART NO.	DESCRIPTION	DET.	QTY	PART NO.	DESCRIPTION
1	1	610615	ELECT HYD STACT VLV, 6 SECT	39	614384	08C1T-08FJX-08FJX-237	H/A
2	2	605615	HYD FILTER, INLINE 25M 9/16FOR	4	618609	3/4MJIC-.90-3/4FJIC SWIV LBO	H/A
3	12	610755	BARNES HYD MOTOR, D-SERIES 01	*41	614627	06C1T-06FJX-06FJX-45	H/A
4	8	618451	3/4FJIC SW RUN TEE-3/4MJIC	42	618118	3/4 HOSE BARB-90-1 1/16MOR	
5	1	606034	MTR CONTROL ELECT VLV	43	611159	3/4MOR PLUG	
*6	1	614633	HYD MANIF 8200 86	44	615621	06C1T-06FJX-06FJX-24	H/A
*7	1	605601	PARKER FILTER ASSY, 10M, 1.25NPT	45	614368	08C1T-08FJX-08FJX-60	H/A
8	4	618620	3/4FJX-90-1/2MNP ADPTR	46	614689	08C1T-08FJX-08FJX-120	H/A
9	1	618310	9/16MJIC-7/8MOR ADPTR	47	614387	08C1T-08FJX-08FJX-267	H/A
10	6	621506	LIFT CYL ASSY 1M, DETASSELER	*48	601378	HOSE, 1 1/4 X 156 1FBR-1SPI	
11	4	690338	LINE CHECK VALVE HYD .50NPT	49	614691	08C1T-08FJX-08FJX-220	H/A
12	1	618692	3/4FJIC SWIV-9/16MOR ADPTR	50	618668	9/16FJIC SWIV-9/16MOR ADPTR	H/A
13	24	611125	3/4MJIC-3/4MOR ADPTR	51	614350	16C2AT-16FJX-16FJX-55	H/A
*14	1	618577	1 5/16MJIC UNION	52	614703	HYD TUBE ASSY, 200 MATN	92
15	1	618440	9/16MJIC-90-9/16MOR EX LG LBO	*53	618532	3/4FJIC CAP NUT	
16	1	618170	3/4MOR-9/16FOR ADPTR	54	614378	08C1T-08FJX-08FJX-207	H/A
17	12	618119	9/16MJIC-90-9/16MOR LBO	55	618444	9/16MOR RUN TEE-9/16MJIC	
*18	2	715660	HOSE BARB 1 1/4NPT X 1 1/4	56	606021	HYD RETURN MANIF, 3/4FOR, 9-PORT	
19	1	618183	3/4MJIC-90-7/8MOR LBO	57	601555	HOSE, 3/4 X 150 1FBR-1SPI	
*20	1	618587	1 5/16FJIC SWIV-1MNP	58	614377	04C1T-06FJX-06FJX-258	H/A
21	1	618600	9/16MJIC-90-7/8MOR LBO	59	618546	04C1T-06FJX-06FJX-174	H/A
*22	2	506410	BLK PIPE ST EL 90DEG 1.25NPT	60	611206	1/8MNP RUN TEE-9/16MJIC	H/A
*23	1	505300	BLK PIPE EL 90DEG 1.00NPT	61	618530	04C1T-06FJX-06FJX-66	H/A
*24	4	611145	3/4MJIC-90-1/2MNP LBO	62	614719	9/16MJIC-1/8MNP ADPTR	
25	2	618590	3/4MJIC-45-3/4FJIC SWIV LBO	63	611246	HYD TUBE ASSY, AUX 204 GMC 96	
*26	1	503700	PIPE PLUG .50NPT SQ HD	64	614101	04C1T-06FJX-06FJX-133	H/A
27	1	618531	9/16FJIC CAP NUT	65	614100	04C1T-06FJX-06FJX-211	H/A
28	4	611147	3/4MJIC-1/2MNP ADPTR	66	614076	04C1T-06FJX-06FJX-119	H/A
29	1	618186	1 5/16MJIC-1 5/16MOR ADPTR	*67	505209	BLK PIPE NIPPLE 1.00NPT-6.00	
30	4	618469	3/4MJIC-1 1/16MOR ADPTR	*68	614561	1.00NPT-1.25 HOSE BARB	
31	1	618126	9/16MJIC-9/16MOR ADPTR	69	601437	HOSE, 1 1/4 X 40 1FBR-1SPI	
32	1	618178	1 5/16MJIC-90-1 5/16MOR LBO	70	618709	9/16MJIC-90-3/4MOR EX LG LBO	
33	8	618115	9/16MJIC-90-3/4MOR LBO	71	618618	9/16MJIC-90-9/16FJIC SWIV LBO	H/A
34	2	614375	08C1T-08FJX-08FJX-177	H/A	614077	04C1T-06FJX-06FJX-88	H/A
35	2	614690	08C1T-08FJX-08FJX-192	H/A	621520	BOOM HINGE FOLD CYL ASSY	
36	1	606090	BRAND HYD VALVE, 2-SECT SER 36	74	614747	.025 ELBOW ASSY, 9/16MOR 90D	
37	1	601440	HOSE, 1 1/4 X 25 1FBR-1SPI	75	616249	04C1T-06FJX-06FJX-273	H/A
38	2	615727	04C1T-06FJX-06FJX-75	H/A			H/A

ABBREVIATIONS

A/C - AIR CONDITIONER	MT - MOUNT
ADPTR - ADAPTER	MTR - MOTOR
AGI - AGITATOR	P/N - PART NUMBER
ALT - ALTERNATOR	PLT - PLATE
ASSY - ASSEMBLY	QTY - QUANTITY
BRKT - BRACKET	RED - REDUCER
DET - DETAIL	REF - REFERENCE
DISPL - DISPLACEMENT	REST - RESTRICTOR
EL - ELBOW	REQ - REQUIRED
EXT - EXTENSION	SHFT - SHAFT
FLO - FLOW	SOL - SOLUTION
FNPT - FEMALE NATIONAL PIPE THREAD	STRG - STEERING
FOR - FEMALE O-RING	ST - STREET
FRT - FRONT	SWIV - SWIVEL
HYD - HYDRAULIC	UNC - UNIFIED NATIONAL COURSE
HYDRO - HYDROSTATIC	UNF - UNIFIED NATIONAL FINE
LG - LONG	V - VOLT
LWR - LOWER	W/ - WITH
MJIC - MALE J.I.C.	WHL - WHEEL
MOR - MALE O-RING	WLD - WELDMENT

INDEX

-A-

ABBREVIATIONS.....	126
ACTUATOR, EXTENSION.....	73
LINEAR.....	73
AIR CLEANER.....	12
BAND.....	12
CAP.....	12
CLAMP.....	12
FILTER.....	12
HOSE.....	12
AIR INTAKE SCREEN.....	13
ARM, SENSOR.....	70
STEERING.....	14, 16, 18, 20

-B-

BAND, AIR CLEANER.....	12
BATTERY.....	40
BOX.....	40
CABLE.....	40
HOLD DOWN.....	40
BELT.....	5
BLADE, CHOPPER.....	62, 63, 64, 65
CUTTER.....	60, 62, 63, 64, 65
FAN.....	5
BLOCK, TERMINAL.....	35
BOX, CONTROL.....	67, 68
MANUAL SWITCH.....	68
BRAKE, SOLNOID.....	23
BREATHER.....	26

-C-

CAB.....	74
CABLE, HYDROSTATIC.....	37
THROTTLE.....	37
CANOPY.....	80, 81
CAP, AIR CLEANER.....	12
FUEL.....	27
RADIATOR.....	13
STEERING.....	33
CHOPPER, BLADE.....	62, 63, 64, 65
MALE ROW.....	62, 63, 64, 65

CIRCUIT BREAKER.....	35
CLAMP, MUFFLER.....	12
TEE.....	7
CONSOLE.....	35
PANEL.....	34
CONTROL BOX.....	67, 68
COVER.....	33
COVER, RECEPTACLE.....	69
CUTTER BLADE.....	60
CASE DRAIN.....	66
HEAD.....	60
CYLINDER FOLD.....	83
STEERING.....	24

-D-

DECALS.....	86, 87
DEPTH COMMAND.....	71, 73
DIAGRAM, WIRING.....	88, 89, 90, 91
DIFFUSER, SUMP.....	26
DIPSTICK.....	26
SENSOR.....	19
DRAIN COCK, RADIATOR.....	13
DRINK HOLDER.....	35
DRIVE ASSEMBLY.....	4

-E-

ELECTRIC VALVE.....	44, 45, 46
ENGINE, CUMMINS.....	4, 5
HOOD.....	38
HOOD PROP.....	38
EXHAUST PIPE.....	12

-F-

FAN BLADE.....	5
FAN SPACER.....	5
FILTER FUEL.....	27
OIL.....	5, 9, 26, 41
FLASHER LIGHT.....	38, 74, 80
SWITCH.....	33
FLOW DIVIDER.....	11
FLOW REGULATOR.....	59

FLUSHING VALVE.....8
 FOAM.....13,30,75,80
 FOLD CYLINDER.....83
 FOLD VALVE.....84
 FRONT LEG.....14,15,16,17
 FUEL
 CAP.....27
 GAUGE.....32
 SELECTOR VALVE.....27
 SENDER.....27
 TANK.....27
 FUSE.....34,71,72
 HOLDER.....34,71,72

-G-

GAUGE,
 FUEL.....32
 OIL PRESSURE.....32
 TEMPERATURE.....32
 GEAR PUMP.....6
 GROUND STRAP.....4

-H-

HANDRAIL.....28,29
 HEAD,
 CUTTER.....60
 PULLER.....59
 HEADLIGHT.....74,80
 HOLD DOWN, BATTERY.....40
 HOLDER, DRINK.....35
 HOSE,
 AIR CLEANER.....12
 RADIATOR.....5
 HOUR METER.....32
 HYDRAULIC
 MOTOR.....59,60,65
 SCHEMATIC.....102
 HYDROSTATIC
 LEVER.....36

-I-

INDICATOR
 LIGHT.....32,33
 MPH/RPM.....32
 INSTRUMENT PANEL.....32

-K-

KIT, LIGHT.....32
 KNOB.....33

-L-

LADDER.....28,29

LEG
 FRONT.....14,16,18,20
 REAR.....18,19,20,21
 SLEEVE, NYLON.....14,16,18,20
 LEVER,
 HYDROSTATIC.....36
 THROTTLE.....37
 LIFTARM.....55
 LIGHT,
 FLASHER.....38,75,80
 KIT.....32
 SWITCH.....34
 LS CROSS TUBE.....70
 LS SENSOR.....70

-M-

MALE ROW CHOPPER.....62,63,64,65
 MANIFOLD, HYDRAULIC.....43
 MANUAL SWITCH.....68
 MOTOR,
 CONTROL VALVE.....42
 MOUNT.....4,5
 STEERING.....33
 MOUNT,
 RADIATOR.....13
 RECEPTACLE.....69
 RUBBER.....4,30
 MPH/RPM INDICATOR.....32
 MUFFLER.....12
 CLAMP.....12
 MULLION.....38

-N-

NOISE DEFLECTOR SHIELD.....30

-O-

OIL
 COOLER.....13
 FILTER.....41
 PRESSURE GAUGE.....32
 PRESSURE SENDER.....4
 TANK.....26
 OPERATOR STATION.....30
 OUTRIGGER.....48,52,56
 FOLD.....83

-P-

PANEL, INSTRUMENT.....32
 PHOTO SENSOR.....70
 PIPE, EXHAUST.....12
 PIVOT PIN.....48,52,56
 PLATFORM, SERVICE.....28,29

POSITRACTION VALVE.....7, 10
 PROP ENGINE HOOD.....38
 PULLER
 HEAD.....59
 SHIELD.....59
 PUMP,
 GEAR.....6
 SUNDSTRAND.....6

-R-

RADIATOR.....13
 HOSE.....5
 MOUNT.....13
 SHROUD.....13
 REAR LEG.....18, 19, 20, 21
 RECEPTACLE
 COVER.....69
 MOUNT.....69
 RECOVERY TANK.....13
 REGULATOR, FLOW.....59
 RELIEF VALVE.....11
 RIM.....22
 ROOF, CANOPY.....80
 RUBBER.....75, 80
 BOOT.....34
 HOOK.....38
 MOUNT.....4, 5, 30

-S-

SCHEMATIC,
 HYDRAULIC.....102
 WIRING.....88
 SCREEN, AIR INTAKE.....13
 SEAT.....31
 SELECTOR VALVE FUEL.....27
 SENDER,
 FUEL.....27
 OIL PRESSURE.....4
 TEMPERATURE.....5
 SENSOR, MPH.....19
 SERVICE PLATFORM.....28, 29
 SHEET METAL.....38, 39
 SHIELD,
 HEAT.....13
 NOISE DEFLECTOR.....30
 PULLER.....59
 WHEEL MOTOR.....15, 17, 19, 21
 SHROUD, RADIATOR.....13
 SMV SIGN.....39
 SPACER,
 FAN.....5
 STABILIZER TUBE.....38, 49, 52, 56
 STALK GUIDE.....59, 60

STEERING,
 ARM.....14, 16, 18, 20
 CYLINDER.....24
 MOTOR.....33
 POST.....33
 WHEEL.....33
 STRAP, GROUND.....4
 SUNDSTRAND PUMP.....6
 SUPPORT POST.....48, 52, 56
 SWITCH.....30
 BOX.....71, 72
 FLASHER.....33
 LIGHT.....34
 TOGGLE.....34, 71, 72

-T-

TAILLIGHT.....39
 TANK,
 FUEL.....27
 OIL.....26
 TEE CLAMP.....7
 TEMPERATURE
 GAUGE.....32
 SENDER.....5
 TERMINAL BLOCK.....35
 THROTTLE
 CABLE BRACKET.....4
 LEVER.....37
 TIE BAR.....48, 52, 56
 TIE ROD.....25
 TIRE.....22
 PULLER.....59
 TOGGLE SWITCH.....34
 TOOLBAR.....48, 49, 52, 56
 TORQUE HUB.....15, 17, 19, 21
 TUBE,
 AIR CLEANER.....12

-V-

VALVE,
 ELECTRIC.....45, 45, 46
 FLUSHING.....8
 FOLD.....84
 MOTOR CONTROL VALVE.....42
 POSITRACTION.....7, 10
 VOLTMETER.....32

-W-

WHEELMOTOR.....15, 17, 19, 21
 WIRING,
 DIAGRAM.....88, 89, 90, 91
 SCHEMATIC.....96

Notes:



PARTS ORDER FAX



Ph. 1 (800) 247-4885 Fx. 1 (515) 532-3553

Photocopy and fax to Hagie Customer Support Department

ORDERED BY/BILL TO:

Name _____
 Co. Name _____
 Street _____
 City, St, Zip _____
 Ph. _____ Fx. _____

SHIP TO:

Name _____
 Co. Name _____
 Street _____
 City, St, Zip _____
 Ph. _____ Fx. _____

HOW SHIP: UPS Ground Next Day 2 Day 3 Day Other _____

If "HOW SHIP" is left blank, parts will be sent UPS ground service. If part is over 150 pounds, an independent motor freight company will be used.

PAYMENT: Hagie Account #*** _____

C.O.D

American Express Discover Visa Master Card
 Signature: _____
 name as appears on card: _____
 card no. _____ exp. date _____

Year and Model No. _____

Serial No. _____

Item Serial No. (if necessary): _____

Engine (include type) _____

Hydrostatic Pump (s) _____

Torque Hub _____ LF RF LR RR

Wheel Motor _____ LF RF LR RR

HAGIE Part No.	Qty.	Description

Check here if you want phone confirmation of parts order.

* Orders received before 3:00 p.m., CST will be processed the same business day.

Regular business hours are Monday through Friday, 7:00 a.m. through 5:00 p.m..

** If you do not have a Hagie account number, contact the Hagie Customer Support Department and you will be issued one.



PARTS ORDER FAX

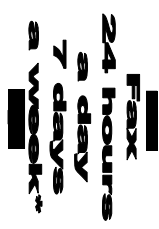

Ph. 1 (800) 247-4885 Fx. 1 (515) 532-3553

Photocopy and fax to Hagie Customer Support Department

ORDERED BY/BILL TO:

Name _____
 Co. Name _____
 Street _____
 City, St, Zip _____
 Ph. _____ Fx. _____

SHIP TO:

Name _____
 Co. Name _____
 Street _____
 City, St, Zip _____
 Ph. _____ Fx. _____

HOW SHIP: UPS Ground Next Day 2 Day 3 Day Other _____

If "HOW SHIP" is left blank, parts will be sent UPS ground service. If part is over 150 pounds, an independent motor freight company will be used.

PAYMENT: Hagie Account #*** _____

C.O.D

American Express Discover Visa Master Card

Signature: _____
 name as appears on card: _____
 card no. _____ exp. date _____

Year and Model No. _____

Serial No. _____

Item Serial No. (if necessary): _____

Engine (include type) _____

Hydrostatic Pump (s) _____

Torque Hub _____ LF RF LR RR

Wheel Motor _____ LF RF LR RR

HAGIE Part No.	Qty.	Description

Check here if you want phone confirmation of parts order.

* Orders received before 3:00 p.m., CST will be processed the same business day.
 Regular business hours are Monday through Friday, 7:00 a.m. through 5:00 p.m..
 ** If you do not have a Hagie account number, contact the Hagie Customer Support Department and you will be issued one.