

CALIFORNIA

Proposition 65

WARNING: Diesel engine exhaust and some of its constituents are known to the State of California to cause cancer and birth defects or other reproductive harm.

WARNING: Battery posts, terminals, and related accessories contain lead and lead compounds, chemicals known to the State of California to cause cancer and birth defects or other reproductive harm.



ANY PICTURES CONTAINED WITHIN THIS OPERATOR'S MANUAL THAT DEPICT SITUATIONS WITH SHIELDS, GUARDS, RAILS, OR LIDS REMOVED ARE FOR DEMONSTRATION PURPOSES ONLY. HAGIE MANUFACTURING COMPANY STRONGLY URGES THE OPERATOR TO KEEP ALL SHIELDS AND SAFETY DEVICES IN PLACE AT ALL TIMES.

HAGIE

MODEL 204 SP



OPERATOR'S MANUAL FOR

HAGIE MANUFACTURING COMPANY

BOX 273 CLARION, IOWA 50525

(515) 532-2861

COVERS MACHINE SERIAL NUMBERS: U1010560001 thru U1010560200

05-26 493347

© 2003 Hagie Manufacturing Company. Clarion, Iowa USA

ABBREVIATIONS

| | | | |
|--------------|---------------------|------------|---------------------------------|
| A/C | AIR CONDITIONING | MT..... | MOUNT |
| ADJ | ADJUST | MTH..... | MONTH |
| ADPTR | ADAPTER | MTR..... | MOTOR |
| ALT..... | ALTERNATOR | NO | NUMBER |
| AMP | AMPERE | OD | OUTSIDE DIAMETER |
| APPROX | APPROXIMATELY | PLT | PLATE |
| ASSY..... | ASSEMBLY | PRESS..... | PRESSURE |
| AUX..... | AUXILIARY | PRKNG..... | PARKING |
| BRKT..... | BRACKET | PSI..... | POUNDS PER SQUARE INCH |
| BTRY..... | BATTERY | QT | QUART |
| C..... | CELSIUS | RAD | RADIATOR |
| CCA..... | COLD CRANKING AMPS | REC | RECOMMENDED |
| CTRL..... | CONTROL | REQ..... | REQUIRED |
| CYL | CYLINDER | RPM..... | REVOLUTIONS PER MINUTE |
| DIAG..... | DIAGRAM | SAE..... | SOCIETY of AUTOMOTIVE ENGINEERS |
| DIM..... | DIMENSION | SEC | SECOND |
| DISPL..... | DISPLACEMENT | SERV | SERVICE |
| EA | EACH | SLCTR..... | SELECTOR |
| ELECT..... | ELECTRIC | SMV | SLOW MOVING VEHICLE |
| F | FAHRENHEIT | SOLE | SOLENOID |
| FIG | FIGURE | SPEC..... | SPECIFICATION |
| FLO | FLOW | STRG..... | STEERING |
| FRT | FRONT | SQ..... | SQUARE |
| FT..... | FOOT OR FEET | TACH..... | TACHOMETER |
| GA | GAUGE | TEMP..... | TEMPERATURE |
| GAL | GALLON | TERM..... | TERMINAL |
| HAL | HALOGEN | TRD | TREAD |
| HR..... | HOUR | TT | TUBE-TYPE |
| HYD..... | HYDRAULIC | TU | TUBELESS |
| HYDRO | HYDROSTATIC | VAR | VARIABLE |
| ID..... | INSIDE DIAMETER | V | VOLT |
| IN..... | INCH | VFC..... | VARIABLE FLOW CONTROL |
| INFO..... | INFORMATION | VLV..... | VALVE |
| Km/H | KILOMETERS PER HOUR | W | WEIGHT |
| LB..... | POUND | W/ | WITH |
| LS..... | LIGHT SENSOR | W/O..... | WITHOUT |
| MAINT..... | MAINTENANCE | WHL..... | WHEEL |
| MIN..... | MINUTE | WK..... | WEEK |
| M/F | MAINFRAME | WLD..... | WELDMENT |
| MPH | MILES PER HOUR | | |

TO THE OWNER

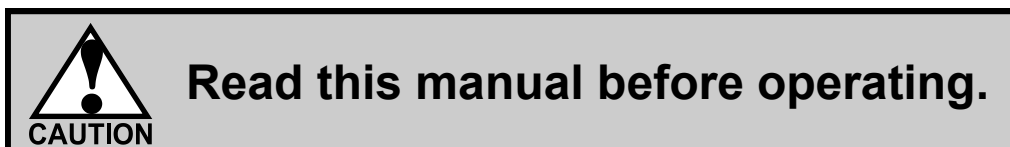

A WORD FROM HAGIE MANUFACTURING COMPANY

Congratulations on your selection of a Hagie Model 204 SP DETASSELER. We recommend that you study this Operator's Manual and become acquainted with the adjustments and operating procedures before attempting to operate your new detasseler. As with any piece of equipment, certain operating procedures, service, and maintenance are required to keep it in top running condition.

We have attempted herein to cover all of the adjustments required to fit varying conditions. However, there may be times when special care must be considered.

Hagie Manufacturing Company reserves the right to make changes in the design and material of any subsequent detasseler without obligation to existing units.

We thank you for choosing a Hagie detasseler and assure you of our continued interest in its satisfactory operation for you. If we might be of assistance to you, please call us.

We are proud to have you as a customer.

CAUTION

READ OPERATOR'S MANUAL. BE ALERT. LEARN TO OPERATE THIS MACHINE SAFELY. OBSERVE ALL SAFETY PRACTICES. MACHINES CAN BE HAZARDOUS IN THE HANDS OF AN UNFAMILIAR, UNTRAINED, OR COMPLACENT OPERATOR. SHUT OFF ENGINE BEFORE SERVICING. WHEN MECHANISM BECOMES CLOGGED, SHUT OFF ENGINE BEFORE CLEANING. DON'T RISK INJURY OR DEATH.

TO THE OPERATOR

The following pages and illustrations will help you operate and service your new detasseler. It is the responsibility of the user to read the Operator's Manual and comply with the safe correct operating procedures and lubricate and maintain the product according to the maintenance schedule.

The user is responsible for inspecting the machine and having parts repaired or replaced when continued use of the product causes damage

or excessive wear to other parts.

Keep this manual in a convenient place for easy reference when problems arise. This manual is considered a permanent fixture with this machine. In the event of resale, this manual should accompany the detasseler. If you do not understand any part of the manual or require additional information or service, contact the Hagie Customer Support Department:

Hagie Manufacturing Company
Box 273, Clarion, IA 50525
(515) 532-2861

The following symbols, found throughout this manual, alert you to potentially dangerous conditions to the operator, service personnel, or the equipment.



This symbol indicates an immanently hazardous situation which, if not avoided, will result in death or serious injury.



This symbol indicates a potentially hazardous situation which, if not avoided, could result in death or injury.



This symbol indicates a potentially hazardous situation which, if not avoided, may result in minor or moderate injury. It may also be used to alert against unsafe

TABLE OF CONTENTS

| | | |
|-------|---------------------------------|---------|
| I. | SAFETY/DECALS | 4-13 |
| II. | DETASSELER IDENTIFICATION | 14-15 |
| III. | SPECIFICATIONS | 16-22 |
| IV. | PREPARING TO OPERATE..... | 23-37 |
| V. | OPERATING INFORMATION..... | 38-70 |
| VI. | TRANSPORTING | 71-72 |
| VII. | SERVICE AND MAINTENANCE..... | 73-100 |
| VIII. | STORAGE | 101-102 |
| IX. | TROUBLE SHOOTING..... | 103-118 |
| X. | LIMITED WARRANTY..... | 119 |
| | INDEX..... | 120 |

| |
|--------------------------------------|
| SAFETY/ DECALS |
| DETASSELER IDENTIFICATION |
| SPECIFICATIONS |
| PREPARING TO OPERATE |
| OPERATING INFORMATION |
| TRANSPORTING |
| SERVICE/ MAINTENANCE |
| STORAGE |
| TROUBLE SHOOTING |
| LIMITED WARRANTY |
| INDEX |

I. SAFETY/DECALS

SAFETY PRECAUTIONS

Most accidents occur as the result of failure to follow simple and fundamental safety rules. For this reason, most accidents can be prevented by recognizing the real cause and doing something about it before the accident occurs.

Many conditions cannot be completely safeguarded against without interfering with efficient operation and/or reasonable accessibility.

Therefore, you must study this Operator's Manual and learn how to use the detasseler controls for safe operation. Likewise, do not let anyone operate without instruction.

Do not make modifications such as weldments, add-ons, adaptations, or changes from the original design of detasseler. Such changes and/or modifications may become safety hazards

DRIVING

- Before moving the detasseler, make sure no persons or obstructions are in the path of travel.
- Do not permit passengers on the detasseler when it is moving; they may fall off or obstruct the operator's view.
- Never drive near ditches, embankments, holes, mounds, or other obstacles.
- Never drive on hills too steep for safe operation.
- Always drive at a reasonable field speed.
- Reduce the detasseler's speed before turning.
- Come to a complete stop before reversing direction.
- Pull over to the side of road before stopping.
- Use the flashing/hazard warning lights when traveling on public roads, day or night, unless prohibited by local law.
- Make sure the SMV emblem is in place and visible from the rear when traveling on public roads.

I. SAFETY/DECALS

OPERATING

TREAD WIDTH

- Select the widest tread setting to fit between the crop rows.
- Never manually adjust the tread width on the detasseler until the wheels have been properly blocked. Loosen the leg clamp bolts only enough for the leg to slide on the frame.

OUTRIGGERS

- Make sure the outriggers are locked down either when folded in or folded out.

GENERAL OPERATION SAFETY

- Do not adjust the factory engine RPM settings.
- Start the engine from the operator's seat only. Do not by-pass the safety-start switch.
- Handle starting fluid with care. Keep it away from open flame. Store it with the cap on in a cool place.
- Never run the detasseler engine in a closed building. Proper exhaust ventilation is required.
- If equipped with light sensing depth units, do not look directly into light beam. It emits a very low intensity microwave signal which may cause possible eye damage.
- Keep all shields in place.
- Keep clear of all moving parts and keep others away when operating.
- Do not wear loose fitting clothing that may be blown or drawn into moving parts.
- Never allow walking personnel in the same field as a detasseler.
- Keep a fire extinguisher close at all times.

SAFETY/
DECALS

DETASSELER
IDENTIFICATION

SPECIFICATIONS

PREPARING
TO OPERATE

OPERATING
INFORMATION

TRANSPORTING

SERVICE/
MAINTENANCE

STORAGE

TROUBLE
SHOOTING

LIMITED
WARRANTY

INDEX

I. SAFETY/DECALS

REPAIR/MAINTENANCE

HYDRAULICS

- Use caution when working with hydraulic fluid under pressure. Escaping hydraulic fluid can have sufficient force to penetrate your skin, causing serious injury. This fluid may also be hot enough to burn.
- Always lower load or relieve hydraulic pressure before repairing a hydraulic oil leak.
- Avoid torching, welding, and soldering near pressurized hydraulic lines.

FUELING

- Always turn the engine off and allow it to cool before refueling.
- Do not smoke while refueling.
- Do not fill fuel tank completely. Fuel may expand and run over.

GENERAL REPAIR/MAINTENANCE

- Turn off engine before checking, adjusting, repairing, lubricating, or cleaning any part of the detasseler.
- When servicing the radiator, let engine cool before removing pressurized cap.
- Disconnect the battery ground cable before servicing electrical system or welding on machine.
- When charging battery, connect positive cable to positive terminal and negative cable to negative terminal. Failure to do so may result in an explosion and cause injury. Likewise, avoid battery acid contact and incurring injuries.
- Never pressurize suspension air bags over 100 psi.

I. SAFETY/DECALS

WARNING DECALS

Decals warning you of avoidable danger are located on various parts of the detasseler. They are there for your personal safety and protection. DO NOT remove them. They will fracture upon attempted removal and therefore must be replaced.

Following are locations of important safety decals. Replace them if they are torn or missing. All

warning decals and other instructional Hagie decals or machine striping may be purchased through the Hagie Customer Support Department. To replace decals, be sure that the installation area is clean and dry; decide on exact position before you remove the backing paper.

DECAL LOCATION



650303

Front of operator station.

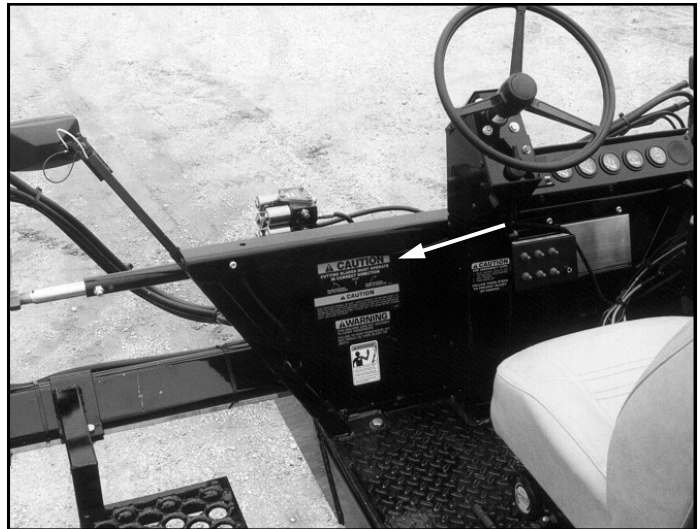

650303

Front window of cab.



DECALS CONTINUED 

I. SAFETY/DECALS

EMERGENCY EXIT

**PULL TAB
REMOVE FILLER STRIP
PUSH WINDOW OUT**

650320

Rear of right cab window.

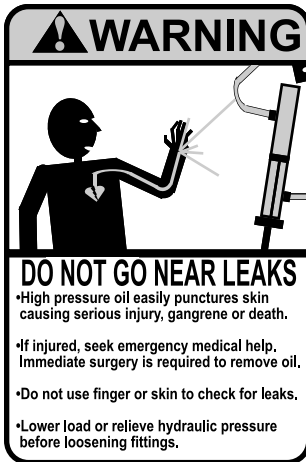

Front of operator station. 650339

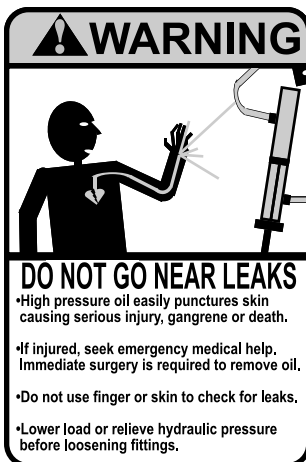

Inside cab door. 650339

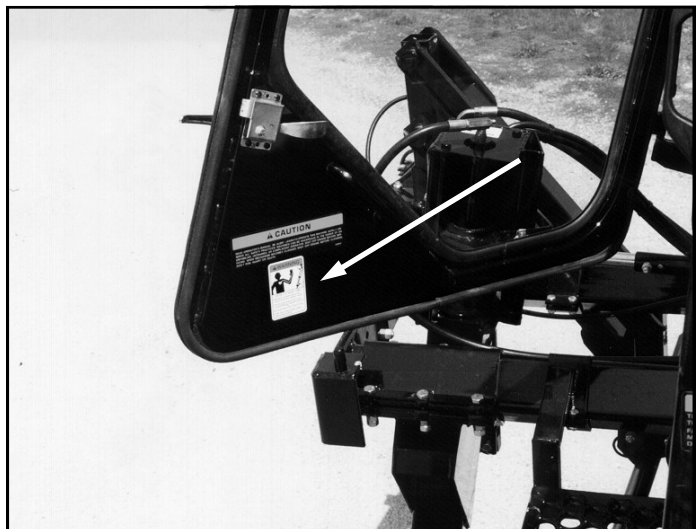

I. SAFETY/DECALS

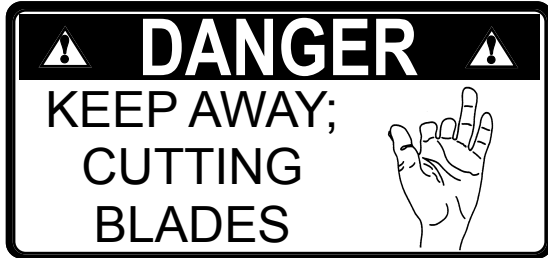

650819

2 on each cutter housing.

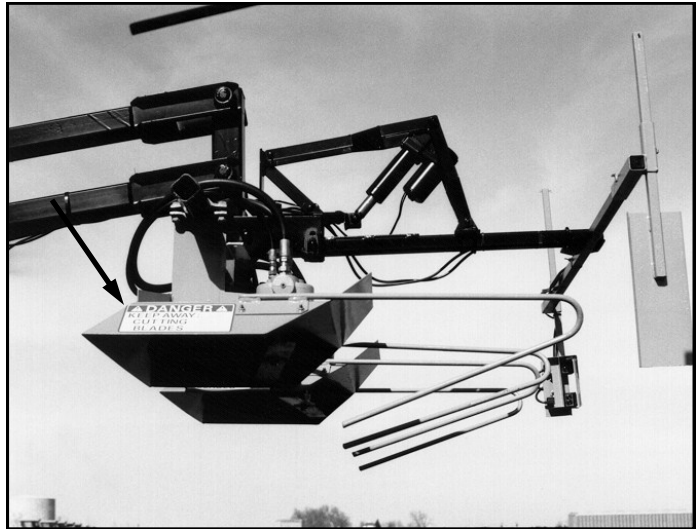

650820

Quad puller head.



650820

2 on each male corn chopper.



DECALS CONTINUED

| | | | | | | | | | | |
|-------|------------------|------------------|---------|----------------------|-----------------------|-------------------------------------|----------------------------------|----------------|-------------------------|----------------|
| INDEX | LIMITED WARRANTY | TROUBLE SHOOTING | STORAGE | SERVICE/ MAINTENANCE | OPERATING INFORMATION | TRANSPORTING INFORMATION TO OPERATE | OPERATING INFORMATION TO OPERATE | SPECIFICATIONS | DETASSEL IDENTIFICATION | SAFETY/ DECALS |
|-------|------------------|------------------|---------|----------------------|-----------------------|-------------------------------------|----------------------------------|----------------|-------------------------|----------------|

I. SAFETY/DECALS



Steering column.

650831



Front of operator station.

650847

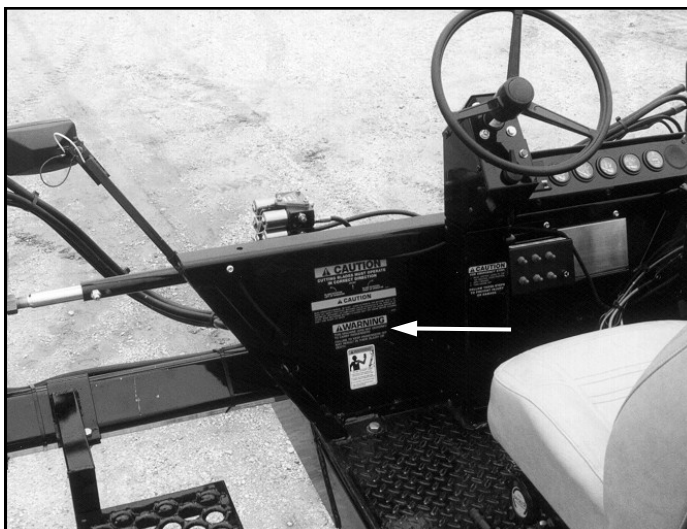

Outside cab, under back window.

650847



I. SAFETY/DECALS



650848

Near each ladder on leg brace.

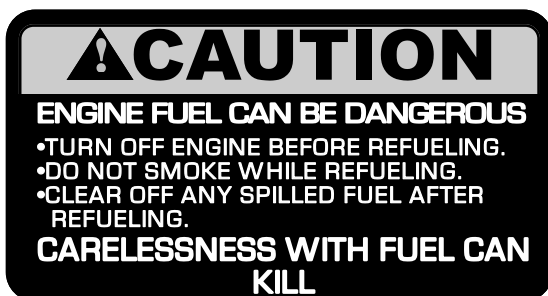
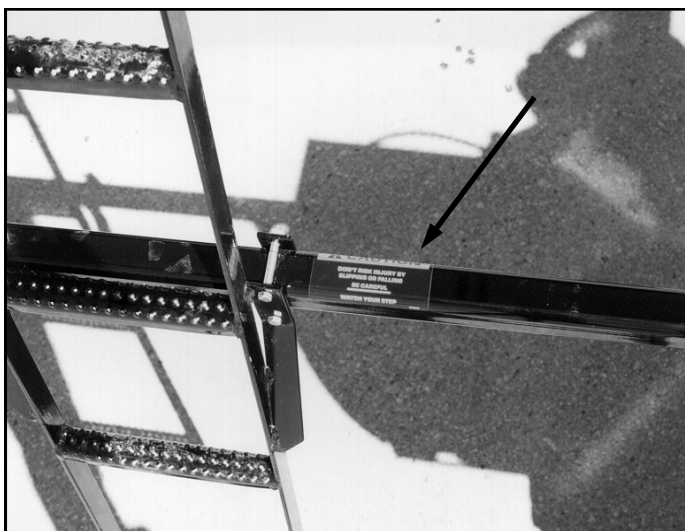

650849

Top of each fuel tank (diesel or gasoline).



650851

Left rear mainframe

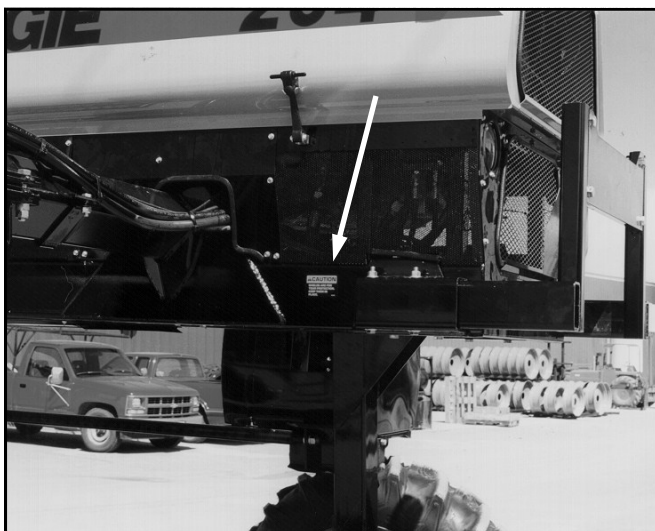

DECALS CONTINUED

SAFETY/
 IDENTIFICATION
 DECALS

DETASLER
 IDENTIFICATION

SPECIFICATIONS

OPERATING PREPARING
 INFORMATION TO OPERATE

OPERATING PREPARING
 INFORMATION TO OPERATE

TRANSPORTING

SERVICE/
 MAINTENANCE

STORAGE

TROUBLE
 SHOOTING

LIMITED
 WARRANTY

INDEX

I. SAFETY/DECALS



650851

Right rear mainframe



650852

Front of operator station.



650852

Inside cab door.



I. SAFETY/DECALS

CAUTION

BEFORE ENGAGING HYDRAULIC MOTORS

1. REDUCE ENGINE SPEED TO AN IDLE
2. CLEAR AREA OF UNAUTHORIZED PERSONNEL

650955

Operator control station.

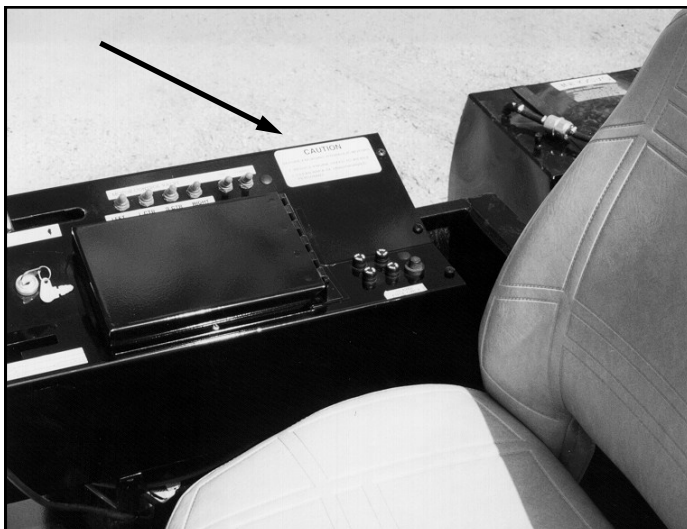

CAUTION

**Pressure cooling system.
Remove cap slowly.**

650981

Front of mullion to left of radiator cap.

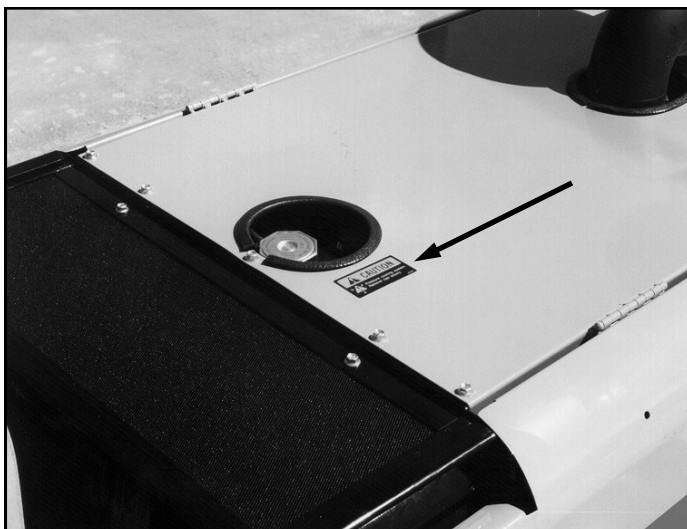

CAUTION

Electrical system is 12 volt negative ground. When using booster with jumper cables, precautions must be taken to prevent personal injury or damage to electrical parts.

1. Attach one end of jumper cable to positive terminal of booster battery and other end to positive terminal of vehicle battery connected to starter motor.
2. Attach one end of second cable to negative terminal of booster battery and other end to vehicle frame away from battery. Do not attach to cab or cab support.
3. To remove cables, reverse above sequence exactly to avoid sparks. See operator's manual for additional information.

650982

Left of battery on hydraulic oil reservoir

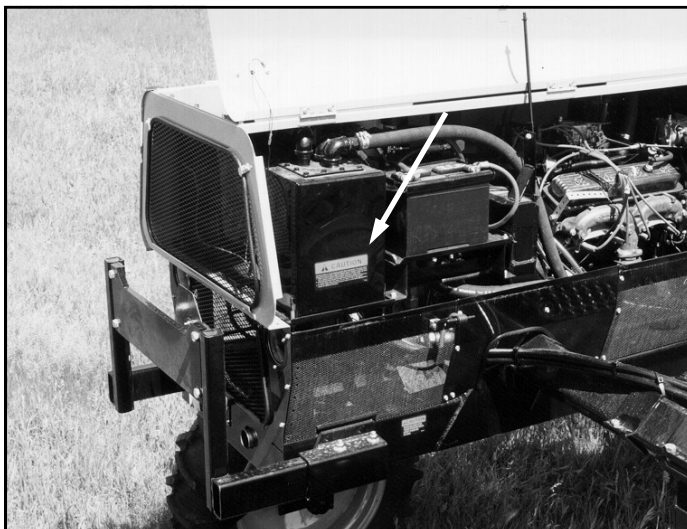

| |
|--|
| SAFETY/ |
| DETAILED IDENTIFICATION |
| SPECIFICATIONS |
| OPERATING PREPARING INFORMATION TO OPERATE |
| OPERATING INFORMATION TO OPERATE |
| TRANSPORTING |
| SERVICE/ MAINTENANCE |
| STORAGE |
| TROUBLE SHOOTING |
| LIMITED WARRANTY |
| INDEX |

II. IDENTIFICATION NUMBERS

DETASSELER IDENTIFICATION

Each Hagie detasseler is identified by means of a frame serial number. This serial number denotes the model, year in which it was built, and the number of the detasseler. For further identification, the engine has a serial number, the hydrostatic pump has a serial number, the wheel motors have identification tags, and the planetary

hubs have identification plates that describe the type of mount and gear ratio. To ensure prompt, efficient service when ordering parts or requesting service repairs from Hagie Manufacturing Company, record the serial and identification numbers in the space provided below.

NOTE:

Reference to left-hand and right-hand used throughout this manual refers to the position when seated in the operator's seat facing forward.



Detasseler

NOTE: Detasseler serial number stamped in the frame on right rear corner.



Engine

NOTE: Diesel engine serial number located on the side of the front left gear housing.

II. IDENTIFICATION NUMBERS

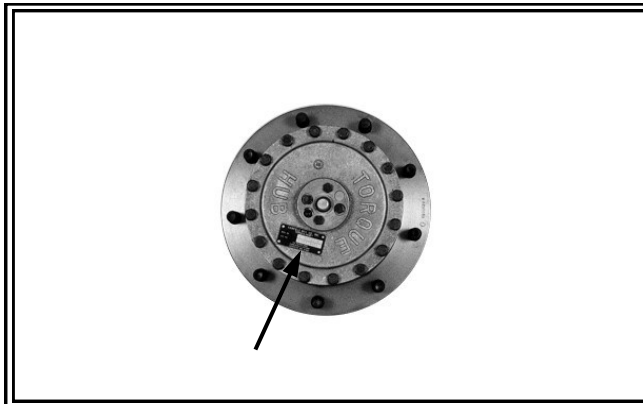

Front Planetary Hubs w/Wheel Motors

Left: _____

Right: _____

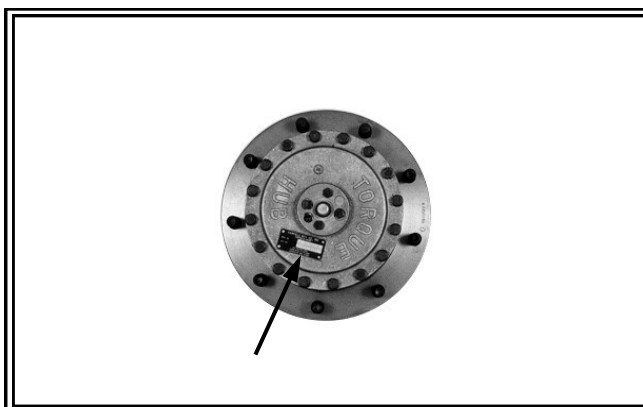

Rear Planetary Hubs

Left: _____

Right: _____

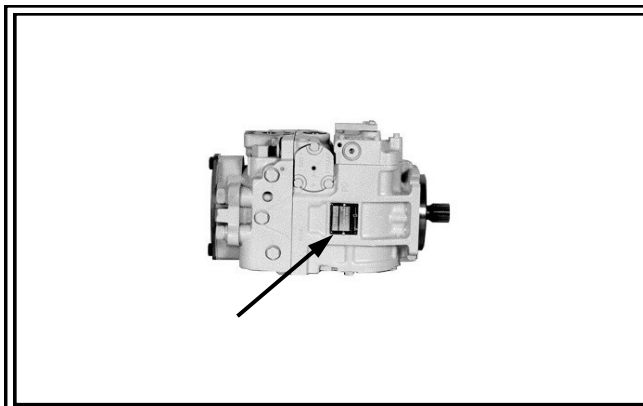

Hydrostatic Pump

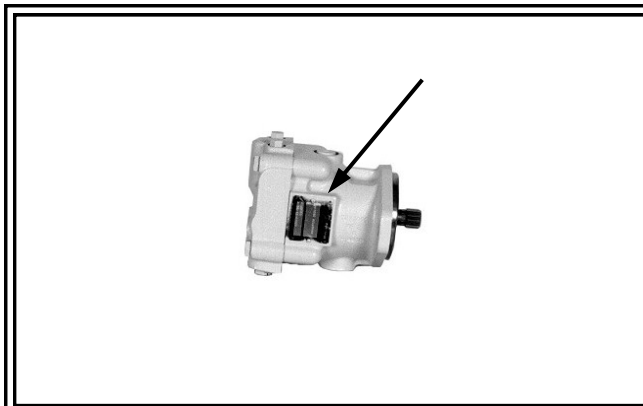

Rear Wheel Motors

Left: _____

Right: _____

Refer to parts manual.

SAFETY/
DETASSELER IDENTIFICATION DECALS

OPERATING INFORMATION TO OPERATE

TRANSPORTING

SERVICE/ MAINTENANCE

STORAGE

TROUBLE SHOOTING

LIMITED WARRANTY

INDEX

III. SPECIFICATIONS

DETASSELER DIMENSIONS

- | | |
|---|---|
| A. Overall tractor height (w/cab or canopy) 139.5" | D. Wheel base 106" |
| B. Lift arm range 53" | E. Detasseler length (w/o attachments) 198" |
| C. Axle height..... 26.2" | F. Diesel exhaust height 139" |

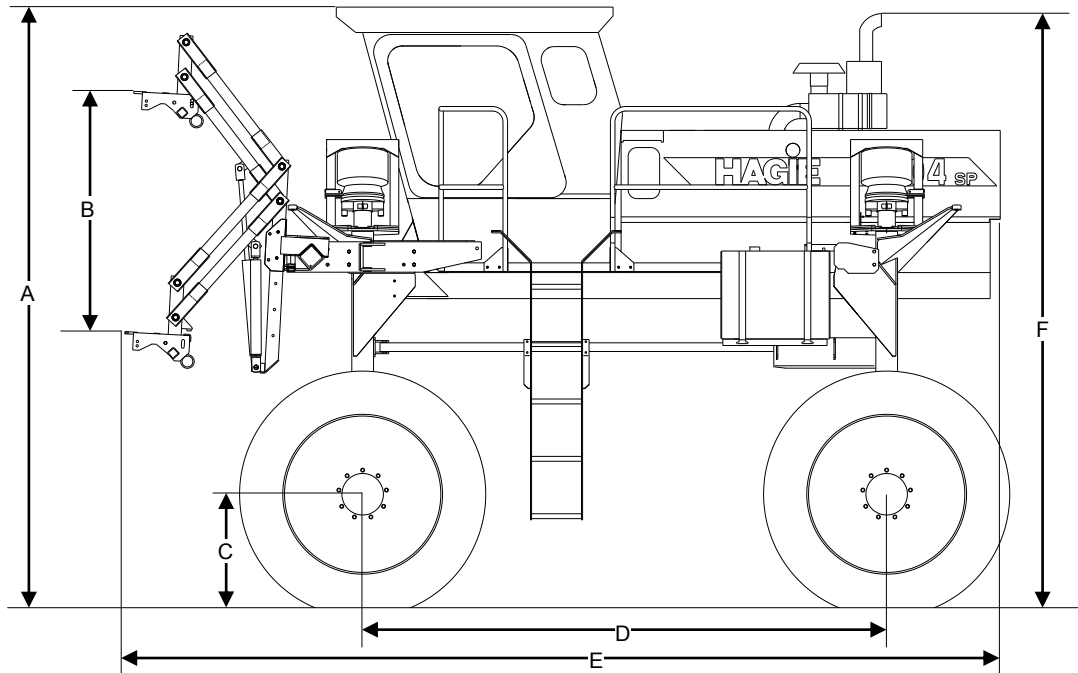

- | |
|---|
| G. Center clearance 71" |
| H. Frame clearance 77" |
| I. Lower leg clearance (front) 24" |
| J. Tire center to inside of lower leg (front) 12.5" |
| K. Tread width* Adjustable 78" - 120" |

*NOTE: Measure tread width at 1/2 tire height.

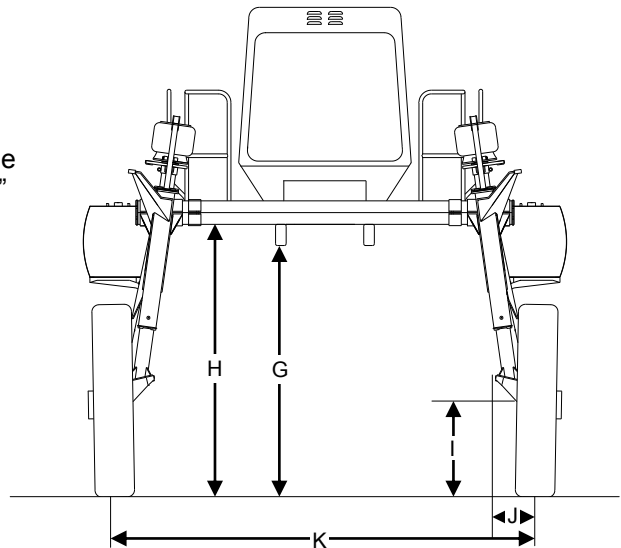

GENERAL DETASSELER INFORMATION

- | | |
|------------------------------|---|
| ♦Frame type | Rigid with 4-wheel, independent, air-suspension |
| ♦Approximate dry weight..... | Refer to page 22 |
| ♦Shipping width | 143" |

III. SPECIFICATIONS

ENGINE

| | |
|---------------------------|-----------------------------|
| Manufacturer | Cummins |
| Model..... | 6B5.9A Turbocharged |
| Type | In line, liquid cooled |
| Number of cylinders | 6 |
| Displacement | 5.9 liter |
| Horsepower..... | 152, intermittent |
| Type of fuel | Number 1 or number 2 diesel |
| Fuel system..... | Filtered, direct-injected |
| Air cleaner | Dry-type, single element |
| Slow idle..... | 800 RPM |
| Fast idle..... | 2500 RPM |

SAFETY/
DETAILED IDENTIFICATION
DECALS

SPECIFICATIONS

PREPARING
TO OPERATE

OPERATING
INFORMATION

TRANSPORTING

SERVICE/
MAINTENANCE

STORAGE

TROUBLE
SHOOTING

LIMITED
WARRANTY

INDEX

III. SPECIFICATIONS

POWER TRAIN

Drive

| | |
|------------------------------|--|
| Hydrostatic pump | Sauer-Danfoss 90 series |
| Range | 100cc variable displacement |
| Drive train | All time four wheel drive |
| Speed | 0-12 mph |
| Hydrostatic wheel motor | |
| - front | Sauer/Sundstrand M35 |
| - rear | Sauer/Sundstrand M25 |
| Final drives | |
| Type | Planetary Gear Reduction Hubs |
| - front (11.2-38 tire) | Torque Hub® W1M Drive ratio - 24.85:1 |
| - rear | Torque Hub® W1B Drive ratio - 18.25:1 |
| Lubrication | Oil bath |

Brakes

| | |
|------------|---|
| Type | Multiple disc Spring applied Hydraulically released |
|------------|---|

Steering System

| | |
|--------------------------|-------------------------------|
| Type | Hydraulic, priority on demand |
| Control | Full-time power |
| Steering cylinders | Double action |
| Turning radius | 18' with 120" tread |

AUXILIARY HYDRAULIC SYSTEM

| | |
|------------------------|-------------|
| Type | Open |
| Pump type | Tandem gear |
| Pressure setting | 2000 PSI |

III. SPECIFICATIONS

ELECTRICAL SYSTEM

General Electrical System

| | |
|------------------|-----------------------------|
| Battery | Single 12V, negative ground |
| Alternator | 105 AMP, voltage regulated |
| Starter | 12V with solenoid |

Circuit Breakers

| | |
|-------------------------------|--------|
| A/C relay (cab only) | 30 AMP |
| Starter relay | 30 AMP |
| Work lights (see below) | 40 AMP |
| Wire harness | 30 AMP |
| Wire harness | 50 AMP |

Fuses

| | |
|--|--------|
| Motor control block | 10 AMP |
| Tasseltrol [®] box, seat motor (cab only) | 10 AMP |
| Gauges, traction valve, dome light (cab only), stereo (cab only) | 10 AMP |
| Hazard/warning lights/turn signal, running lights, Windshield wiper (cab only), fuel pumps (gas only), Fuel selector valve (diesel only) | 10 AMP |
| Depth command switch panel | 10 AMP |

Lights (standard operator station)

| | |
|------------------------|------------------------|
| Front of station | 2 halogen field lights |
|------------------------|------------------------|

Lights (cab or canopy)

| | |
|--------------------|------------------------|
| Front of cab | 4 halogen field lights |
| Rear of cab | 2 halogen work lights |

| |
|---|
| SAFETY/ DETAILED IDENTIFICATION DECALS |
| SPECIFICATIONS |
| PREPARING TO OPERATE |
| OPERATING INFORMATION |
| TRANSPORTING |
| SERVICE/ MAINTENANCE |
| STORAGE |
| TROUBLE SHOOTING |
| LIMITED WARRANTY |
| INDEX |

III. SPECIFICATIONS

OPERATOR STATION

Operator station (standard)

| | |
|--------------------------------|---|
| General operator station | Tilt steering Flashing/hazard warning lights Turn signals |
| Seat | Adjustment for: Fore-aft Height Ride firmness |

Canopy (optional)

| | |
|----------------------|--------------------------|
| General canopy | Same as operator station |
|----------------------|--------------------------|

Cab (optional)

| | |
|----------------------------|---|
| General cab | Same as operator station, also: Windshield wiper Side mirrors Dome light Tinted glass |
| Temperature control | Full-range |
| A/C charge type | R-134a |
| Fresh air filtration | Paper and charcoal filter |
| Seat | Air ride with adjustment for: Fore-aft Backrest Height Ride firmness Armrest tilt |
| Stereo | AM/FM stereo cassette with dual speakers |

Instruments

| | |
|---------------------------------|---|
| Dial gauges | Hour meter Fuel Temperature Alternator Oil pressure |
| Digital gauge | Speedometer (MPH-Km/H) Tachometer (RPM) |
| Engine air filter monitor | Filter Minder® |

III. SPECIFICATIONS

TIRES/RIMS

Rims (front and rear)

Standard.....38" X 10"

Tires (front and rear)

Standard.....11.2-38 (Bias TU)

Air pressure23 PSI

Tire width11"

Load capacity (at 10 mph).....2760 lbs.

Overall diameter55.5"

Static load radius (suggested—will vary with load)26.2"

Rolling circumference165.0"

CAPACITIES

Fuel tanks (2)40 gallons each

Cooling system.....7 gallons

Hydraulic reservoir20 gallons

Engine crankcase: diesel (including filter).....17 quarts

Engine crankcase: gasoline (including filter).....6 quarts

Torque Hub®16 oz. (approx.)

| |
|--|
| SAFETY/ DETAILED IDENTIFICATION DECALS |
| IDENTIFICATION DECALS |
| SPECIFICATIONS |
| PREPARING TO OPERATE |
| OPERATING INFORMATION TO OPERATE |
| TRANSPORTING |
| SERVICE/ MAINTENANCE |
| STORAGE |
| TROUBLE SHOOTING |
| LIMITED WARRANTY |
| INDEX |

III. SPECIFICATIONS

DETASSELING EQUIPMENT OPTIONS

Front mounted with or without LS System

Quad Puller

| | |
|--|---|
| Number of rows available..... | 4, 6, 8, 10, or 12 |
| Drive | Hydraulic |
| Tire size..... | 4.10/3.50 2 ply |
| Operating speed..... | Up to 400 RPM |
| Pulling height..... | Minimum range – 34” to 87” Maximum range – 52” to 105” |
| Weight per head assembly | 86 lbs. |
| Weight: basic machine with 8 row option..... | 7550 lbs. |

Cutter

| | |
|--|---|
| Number of rows available..... | 4, 6, 8, 10, or 12 |
| Drive | Hydraulic |
| Blade size..... | 18” |
| Operating speed..... | Up to 3100 RPM |
| Cutting height | Minimum range – 32” to 85” Maximum range – 50” to 103” |
| Weight per head assembly | 62 lbs. |
| Weight: basic machine with 6 row option..... | 6680 lbs. |

Male corn equipment options

| | |
|-----------------------------------|---|
| Male corn cutter (1 blade) | Hydraulically driven 18” blade |
| Male corn cutter (4 blade) | Hydraulically driven 18” blades (includes one left and one right hand) |
| Male corn chopper (8 blade) | Ground driven 15” blades or Ground driven 20” blades |

IV. PREPARING TO OPERATE

WHEEL TREAD AND ROW SPACING

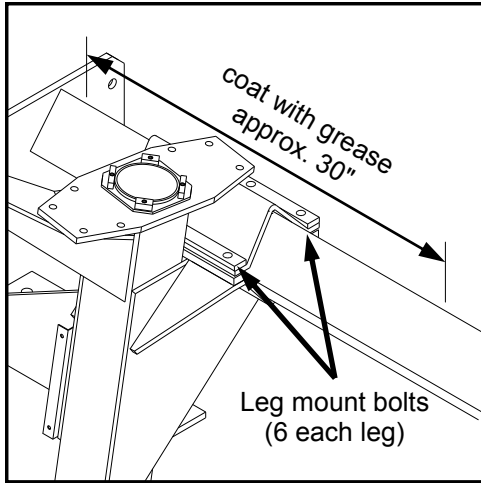

FIG 4.1



FIG 4.2

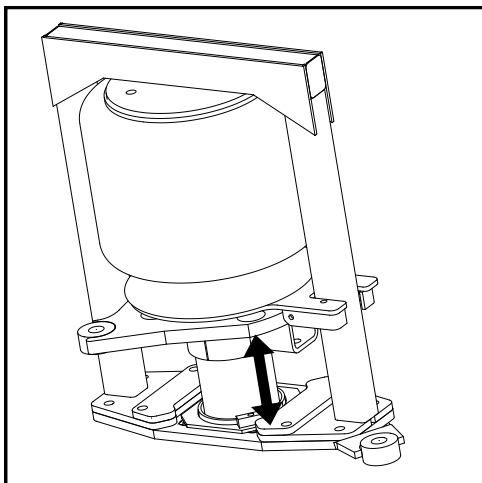

FIG 4.3

Knowing the row spacing of the field one intends to detassel, follow the steps below to properly obtain the desired tread

1. To adjust the tread width in or out, park the detasseler on level ground and shut off the engine.
2. Loosen the leg mounting bolts on both the front and rear legs on one side of the detasseler only (fig. 4.1).



CAUTION

Loosen leg mounting bolts only enough to allow for free movement of leg on mainframe. DO NOT remove bolts under any condition.

3. Loosen the rear lock nut on the leg brace (fig. 4.2). This will allow one leg to move further than the other without binding while adjusting the tread setting.
4. Lubricate the slide path the leg mount will travel along mainframe (fig. 4.1).
5. Place a suitable block under the air bag mounting plate before raising the sprayer (fig. 4.3). This will prevent the suspension from telescoping.
6. Raise the detasseler until the tires on the side being adjusted are just touching the ground.

IV. PREPARING TO OPERATE



FIG 4.4

7. To adjust the tread out, place a suitable prying tool under the center of the tire and pry out at the same time that you push out at the top of the leg (fig. 4.4). Carefully lower the detasseler to the ground which, in turn will allow the leg to slide outward. Repeat the procedure until the desired tread is obtained.
8. To adjust the tread in, raise the detasseler until the tires on the side being adjusted are just off the ground. Carefully lower the detasseler which, in turn will allow the top of the leg to slide in on the mainframe.
9. Retighten leg mounting bolts following the torque specs and sequence on page 95.
10. Retighten the leg brace lock nut.
11. Repeat the above procedures to adjust and set the opposite side legs. When finished, all four legs should be the same distance from

IV. PREPARING TO OPERATE

ATTACHING OPTIONAL COMPONENTS

In shipment, some of the components may have been sent loose and need to be installed before operating. In order to ensure proper installation of the optional attachments, refer to your HAGIE 204 SP Parts Manual for the correct option for out-

lining the installation, hydraulic schematic, and wiring diagram. Read and comply with the following instructions. Always make sure you have proper equipment and help when installing the attachments.



FIG 4.5

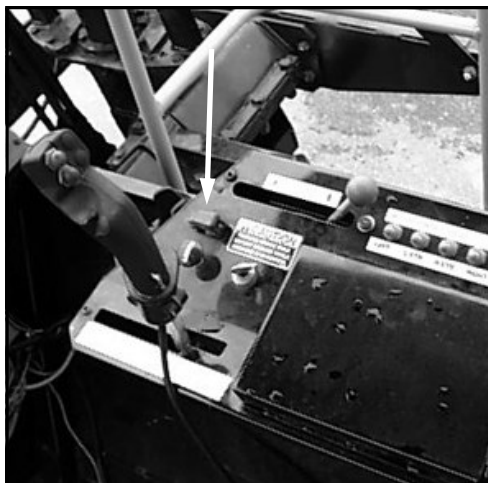

FIG 4.6

CAUTION

Firmly set the parking brake (fig. 4.6) and shut off engine before attaching components. For more information regarding parking brake operation see page 41.

SAFETY/
DETAILED IDENTIFICATION
DECALS

SPECIFICATIONS

PREPARING
TO OPERATE

OPERATING
INFORMATION

TRANSPORTING

SERVICE/
MAINTENANCE

STORAGE

TROUBLE
SHOOTING

LIMITED
WARRANTY

INDEX

IV. PREPARING TO OPERATE

4 – 6 – 8 ROW OUTRIGGER ASSEMBLY

1. Attach the center tool bar (fig. 4.7, item 1) to front frame cross member with supplied hardware according to 204 SP DETASSELER Parts Manual for correct hardware.

NOTE:

The guide pin that is welded to outrigger mount should be located toward the bottom (fig. 4.7, item 2).

2. Attach left and right outrigger (fig. 4.7, item 3) with supplied hardware. Refer to 204 SP DETASSELER Parts Manual.
3. Attach outrigger support rods if required.

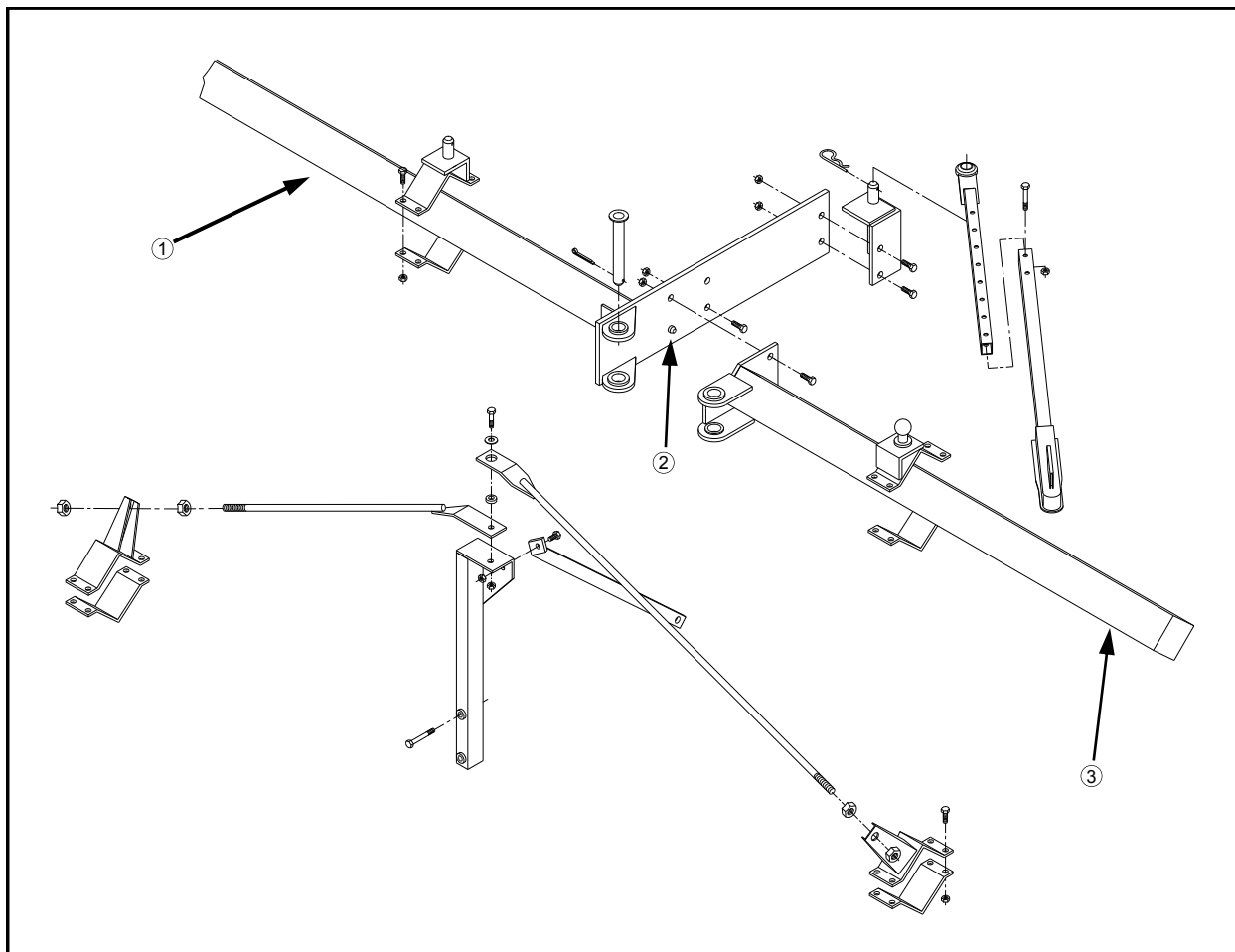

FIG 4.7

IV. PREPARING TO OPERATE

10 – 12 ROW OUTRIGGER ASSEMBLY

1. Attach the center tool bar (fig. 4.8, item 1) to front frame cross member with supplied hardware according to 204 SP DETASSELER Parts Manual for correct hardware.

NOTE:

The guide pin that is welded to outrigger mount should be located toward the bottom (fig. 4.8, item 2).

2. Attach left and right outrigger (fig. 4.8, item 3) with supplied hardware. Refer to 204 SP DETASSELER Parts Manual.
3. Attach outrigger support rods.

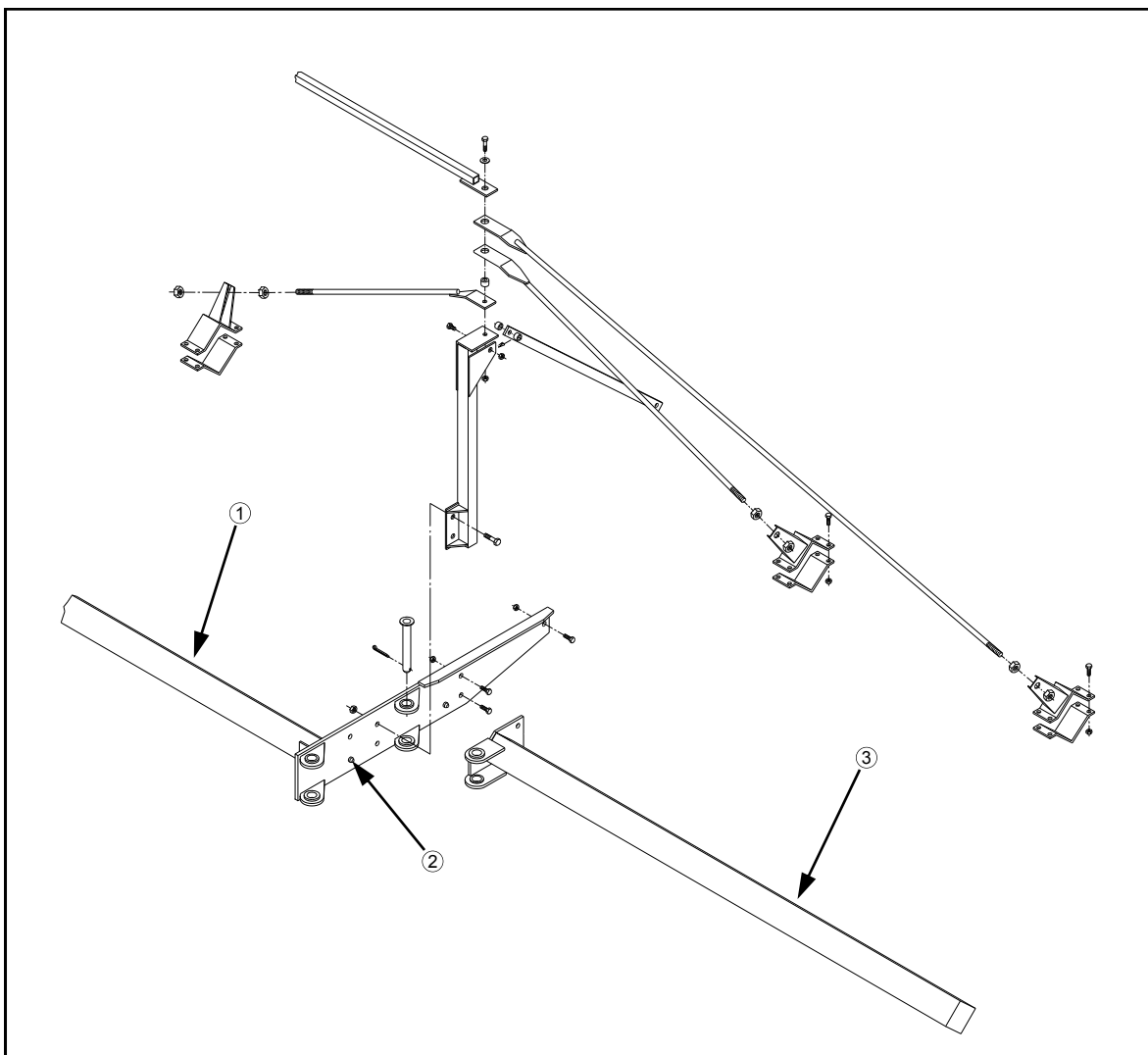

FIG 4.8

IV. PREPARING TO OPERATE

Attaching Lift Assemblies

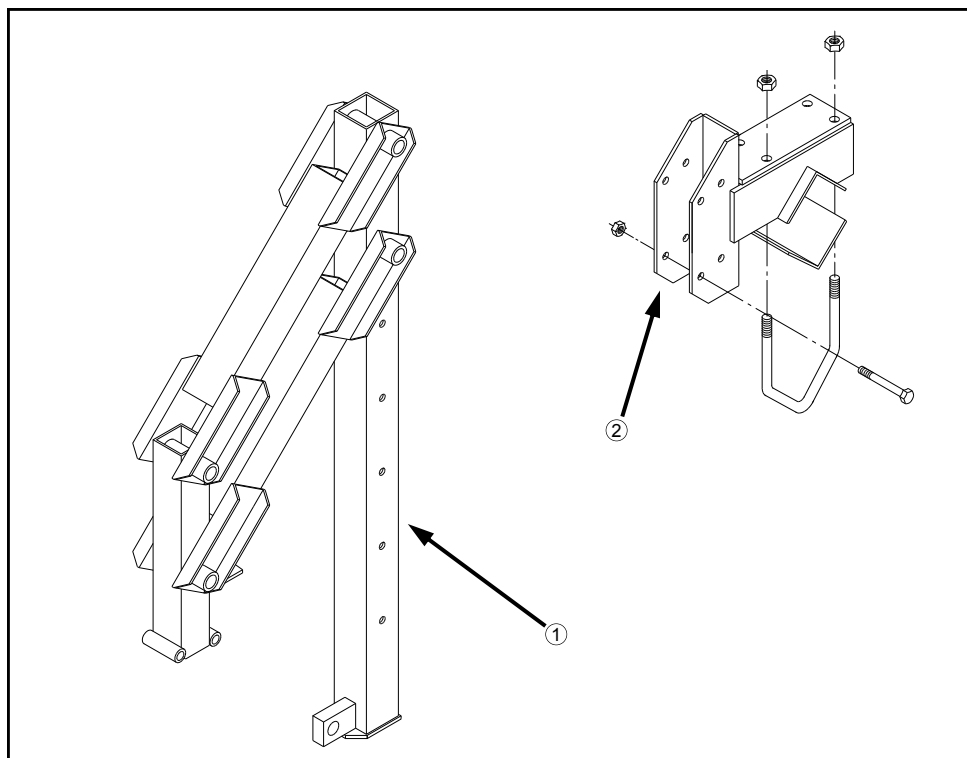

FIG 4.9

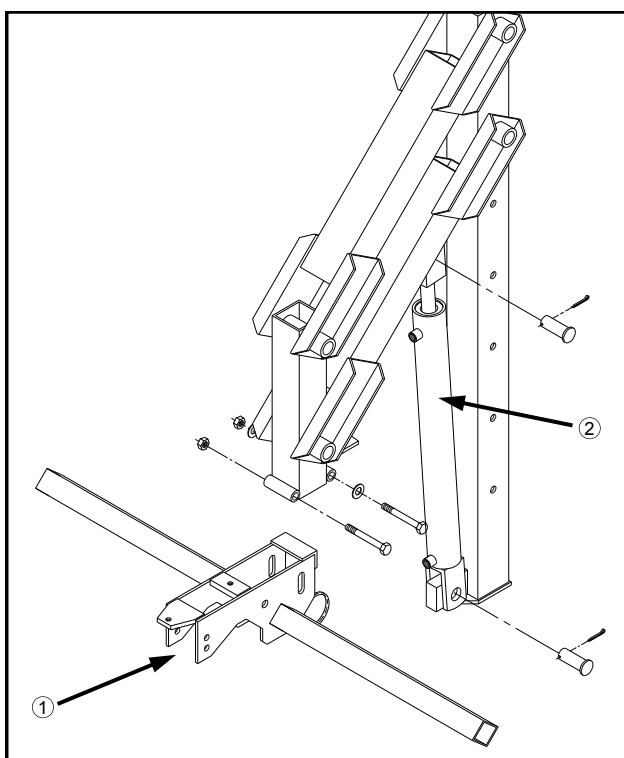

FIG 4.10

Refer to 204 SP DETASSELER Parts Manual for correct hardware when following these steps:

1. Attach the lift mounts (fig. 4.9, item 2) to the tool bar and outriggers at the appropriate spacings.
2. Attach the lift arms (fig. 4.9, item 1) to the lift mounts.
3. Attach the lift arm cylinders to the lift arm assemblies (fig. 4.10, item 2).
4. Attach the tool bar weldment to the lift arm assemblies (fig. 4.10, item 1).
5. Connect hydraulic hoses to lift cylinders. Refer to 204 SP DETASSELER Parts Manual for correct hydraulic schematics.

IV. PREPARING TO OPERATE

ATTACHING QUAD PULLERS



FIG 4.11

1. Attach the quad pullers to each lift arm tool bar (fig. 4.11).

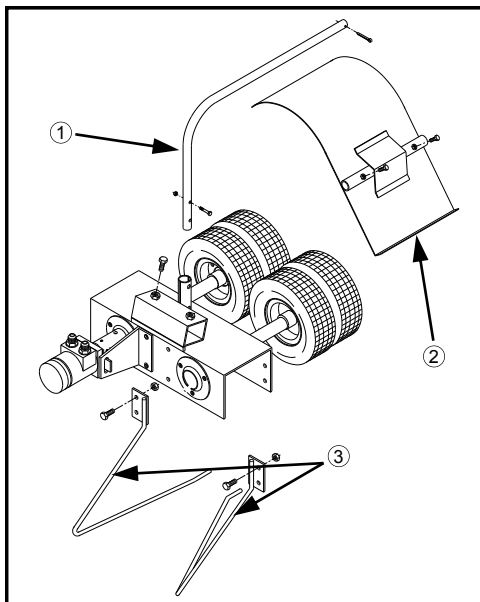

FIG 4.12

2. Install the stalk guides to the quad puller head assembly (fig. 4.12, item 3).
3. Attach the deflector shield mount tube (fig. 4.12, item 1) and the deflector shields for right or left hand deflection (fig. 4.12, item 2).
4. Refer to page 30 for information about installing hydraulic hoses.
5. Normal operating angle of the quad puller is obtained when the tool bar mount surface is parallel to the ground (fig. 4.13, item 1). This angle can be varied by an adjusting bolt (fig. 4.13, item 2) and slot (fig. 4.13, item 3).
6. Adjust tire pressure to approximately 10 pounds.

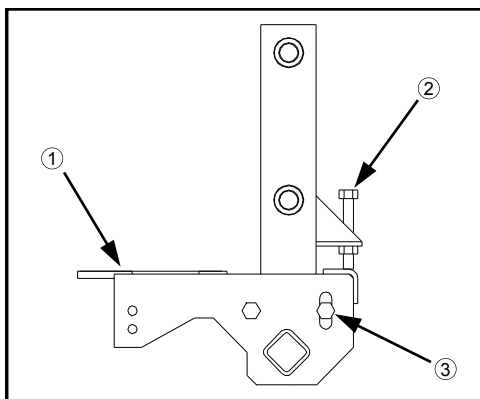

FIG 4.13

NOTE:

Some quad pullers may come pre-assembled to the tool bar. In this case, you would attach them to the lift assem-

NOTE:

Be sure all four tires have equal pressure. Check tire pressure daily.

IV. PREPARING TO OPERATE

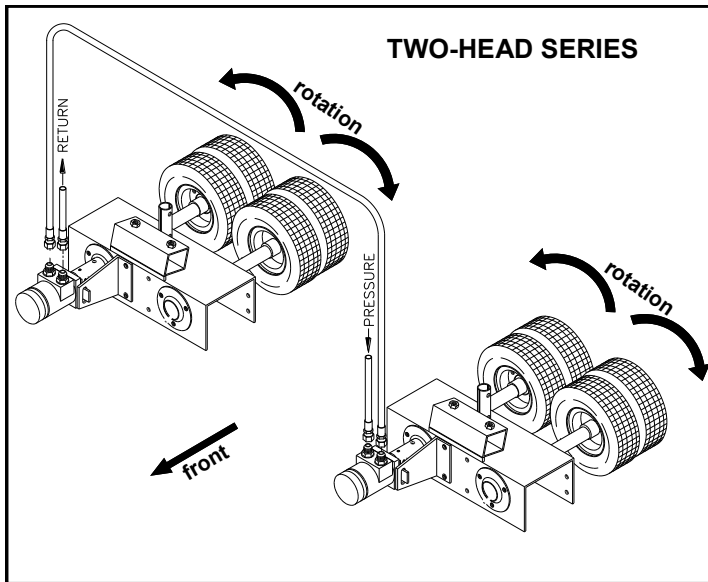

FIG 4.14

Quad Puller Hydraulic Assembly

Hydraulic hoses on Quad Puller heads should be hooked up so tires rotate according to figure 4.14 and figure 4.15. Refer to 204 SP DETASSELER Parts Manual for correct hardware, hose lengths, and hydraulic schematic.

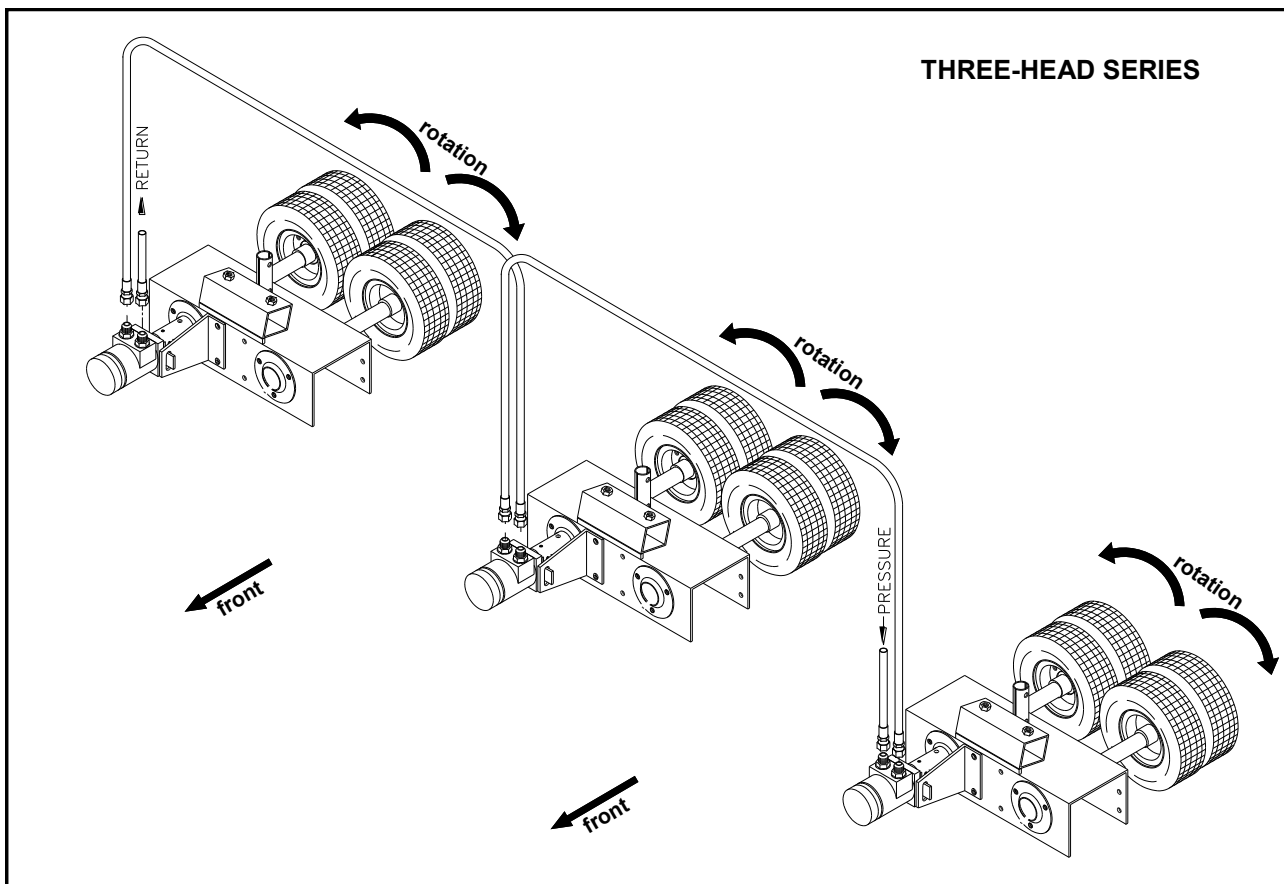

FIG 4.15

IV. PREPARING TO OPERATE

ATTACHING CUTTER HEADS



FIG 4.16

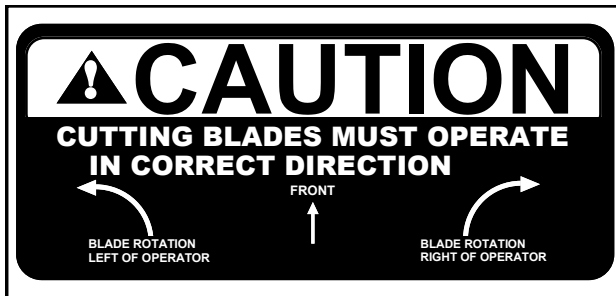

FIG 4.17

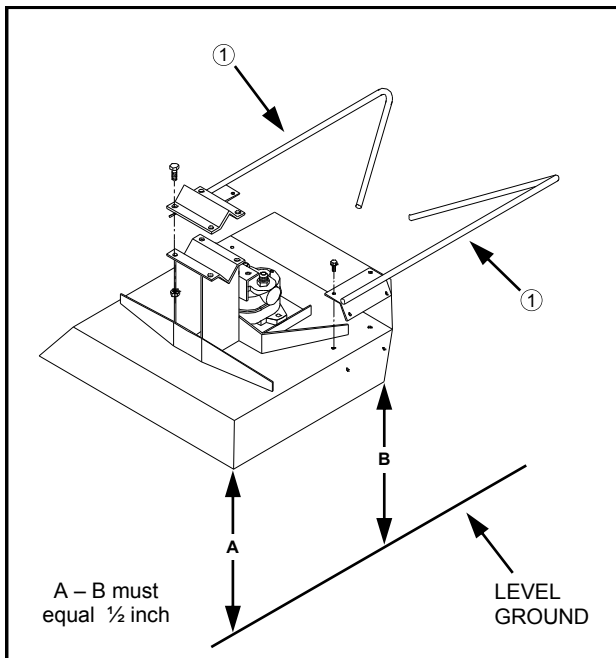

FIG 4.18

1. Attach the cutter head assembly to the tool bar (fig. 4.16).

NOTE:

Some cutters may come pre-assembled to the tool bar. In this case, you would attach the assembly to the lift assembly.

2. Install the stalk guides to the cutter head assembly (fig. 4.18, item 1)
3. Refer to pages 32-33 for information about installing hydraulic hoses.

CAUTION

Make sure the cutter blades operate in the correct direction (fig. 4.17).

4. Adjust the cutter heads using the adjusting bolts so the front of the cutter head is pointing downward approximately $\frac{1}{2}$ inch (fig. 4.18).

IV. PREPARING TO OPERATE

Blade Rotation Left of Operator

Hydraulic hoses on cutter heads should be hooked up so blades on heads mounted left of operator rotate according to figure 4.19 and figure 4.20 (counter-clockwise from above). Refer to 204 SP DETASSELER Parts Manual for correct hardware, hose lengths, and hydraulic schematic.

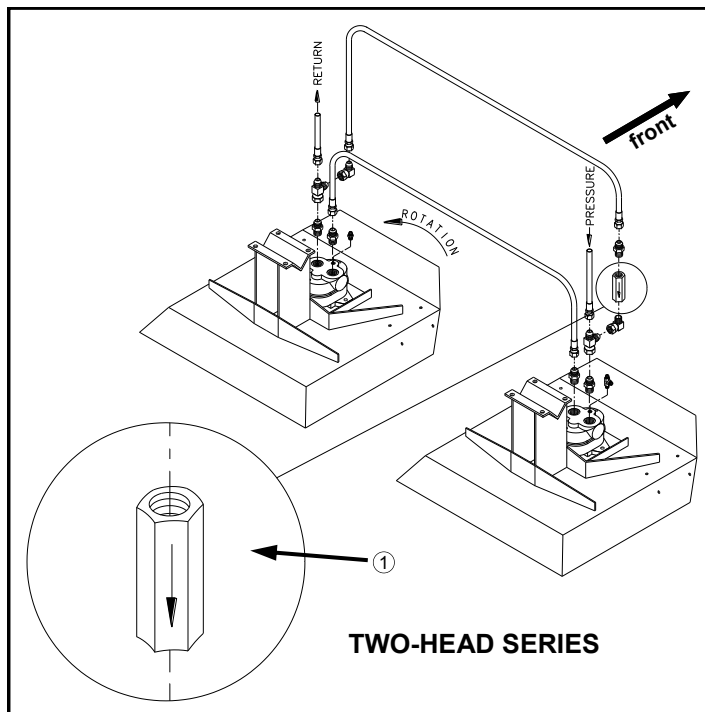

FIG 4.19

NOTE:

Care should be taken when installing check valve (fig. 4.19, item 1) on cutter motor so the flow arrow is oriented correctly (either two-head or three-head series).

IMPORTANT:

Case drain hoses must be installed correctly on cutter motors to prevent motor damage. Refer to parts manual.

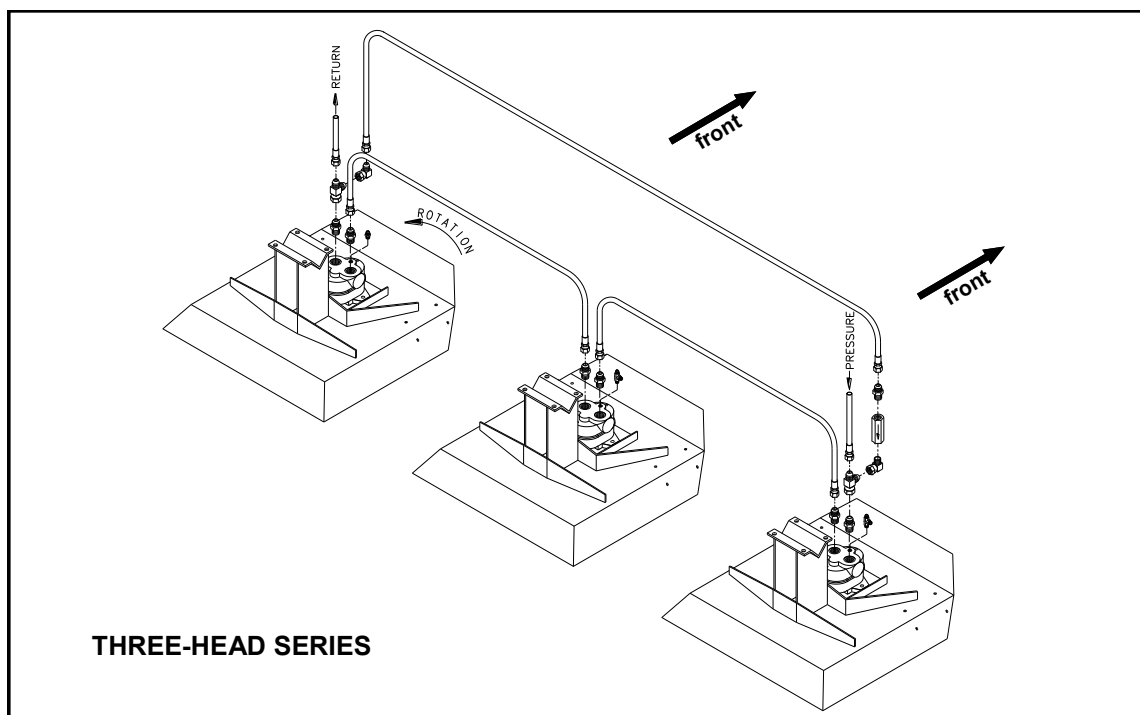

FIG 4.20

IV. PREPARING TO OPERATE

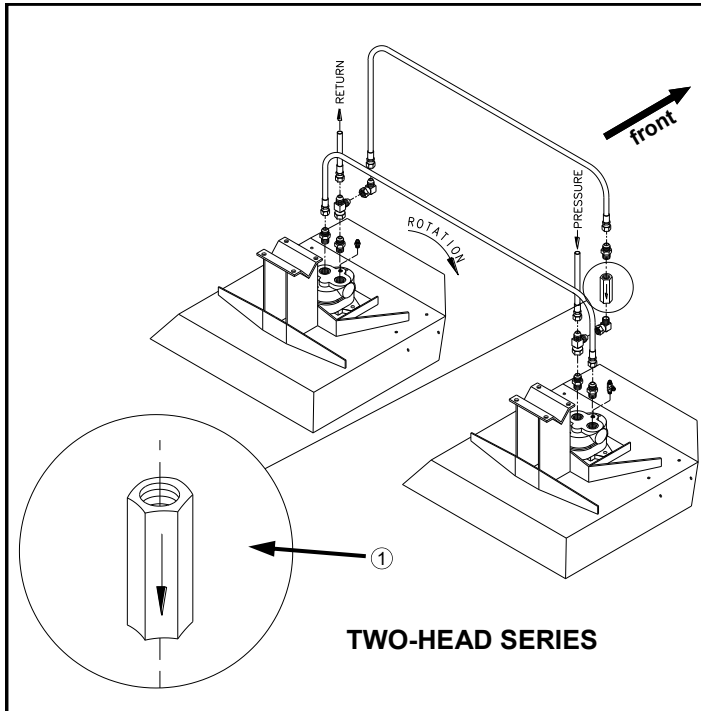

FIG 4.21

Blade Rotation Right of Operator

Hydraulic hoses on cutter heads should be hooked up so blades on heads mounted right of operator rotate according to figure 4.21 and figure 4.22 (clockwise from above). Refer to 204 SP DETASSELER Parts Manual for correct hardware, hose lengths, and hydraulic schematic.

NOTE:

Care should be taken when installing check valve (fig. 4.21, item 1) on cutter motor so the flow arrow is oriented correctly (either two-head or three-head series).

IMPORTANT:

Case drain hoses must be installed correctly on cutter motors to prevent motor damage. Refer to parts manual.

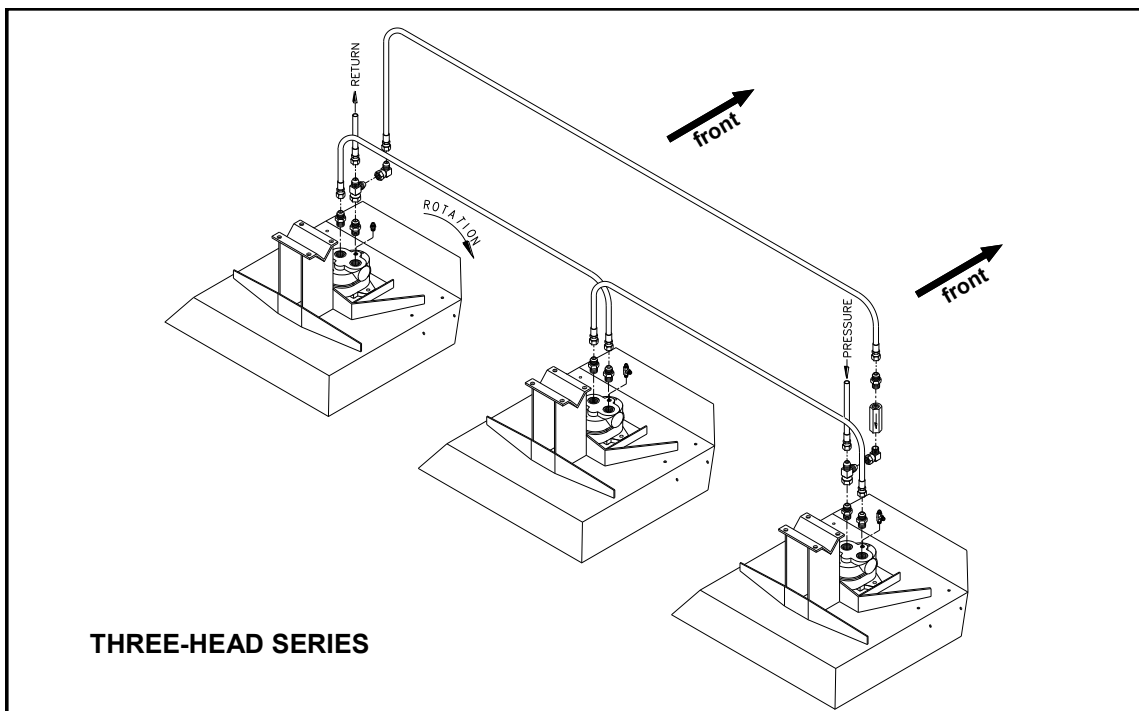

FIG 4.22

| | |
|-----------------------|---------------------------|
| SAFETY/ | DETASSELER IDENTIFICATION |
| SPECIFICATIONS | DECALS |
| PREPARING TO OPERATE | |
| OPERATING INFORMATION | |
| TRANSPORTING | |
| SERVICE/ MAINTENANCE | |
| STORAGE | |
| TROUBLE SHOOTING | |
| LIMITED WARRANTY | |
| INDEX | |

IV. PREPARING TO OPERATE

ATTACHING LS SYSTEM

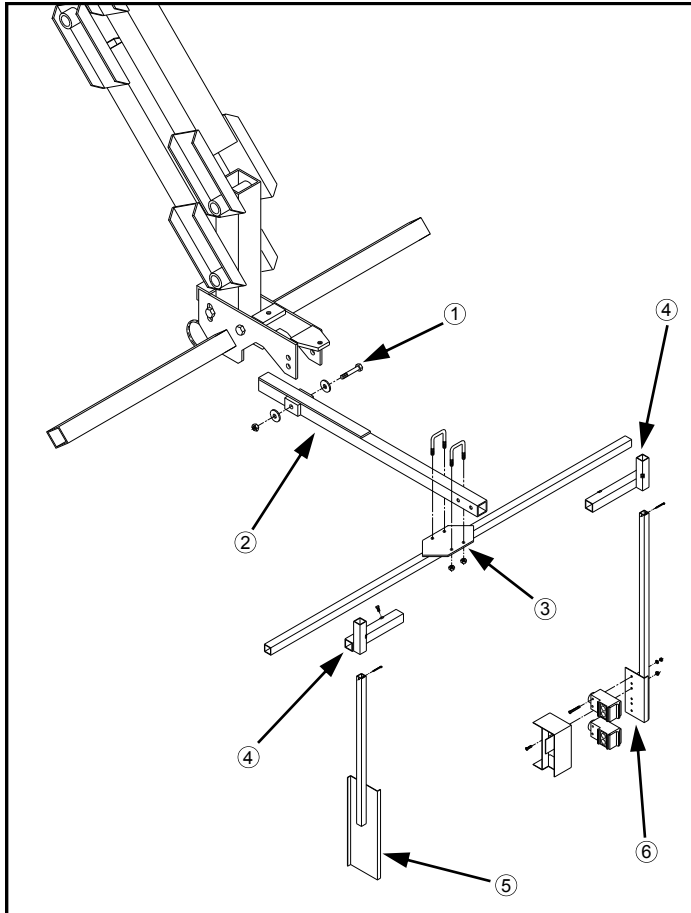

FIG 4.23

1. Install Tasselrol[®]/LS sensor arm weldment with the two nylon washers in the bottom hole in the tool bar (fig. 4.23, item 2).
2. Install the Tasselrol[®]/LS cross tube weldment (fig. 4.23, item 3) to the sensor arm.
3. Install the left and right slide mount weldments (fig. 4.23, item 4) to the cross tube weldment.
4. Install the Tasselrol[®]/LS reflector mount (fig. 4.23, item 5) and sensor mount (fig. 4.23, item 6) to the slide mount weldments.
5. Install the cable assembly according to the wire diagram in your HAGIE 204 SP Parts Manual.
6. With a tape measure, set the center of the top Tasselrol[®] sensor to a depth of seven inches (fig. 4.24). Set the top edge of reflector to three inches (fig. 4.24).
7. Turn the ignition key switch to the "ON" position to check the sensor installation. DO NOT start the engine. See page 57 for more information about the LS sensor assembly.

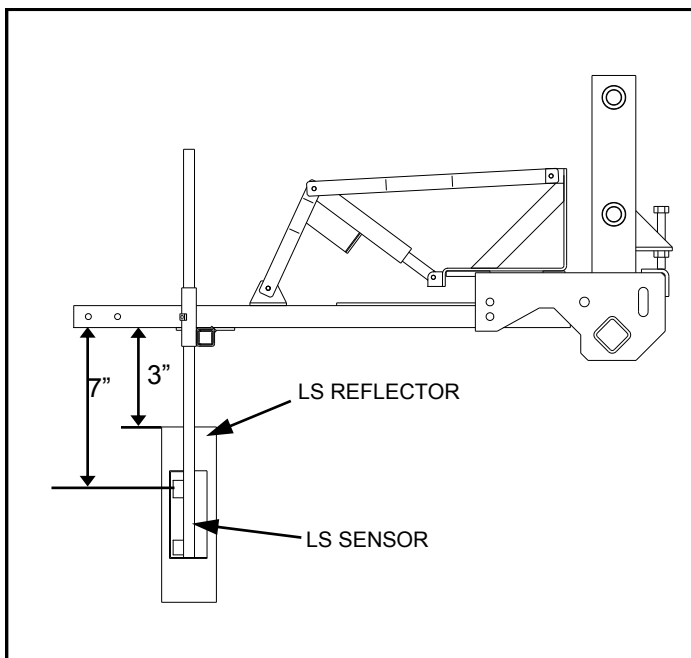

FIG 4.24

IV. PREPARING TO OPERATE

ATTACHING DEPTH COMMAND

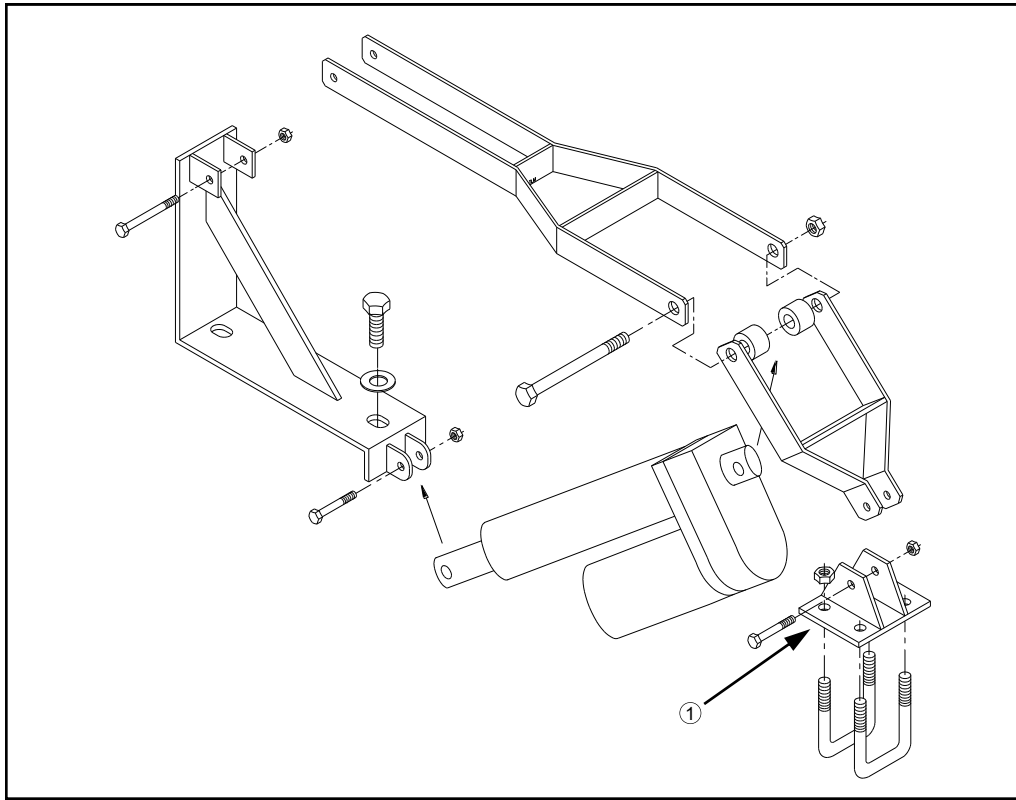

FIG 4.25

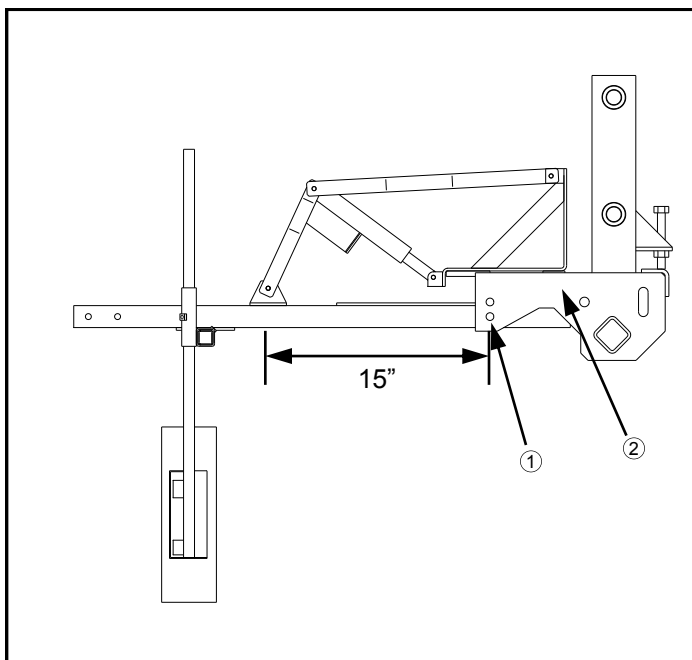

FIG 4.26

1. Attach the depth command actuator assembly (fig. 4.25) to the tool bar (fig. 4.26, item 2).
2. Attach the adjustable slide mount (fig. 4.25, item 1) to the sensor arm approximately 15 inches away from the sensor arm pivot (fig. 4.26, item 1). This should give you equal travel distance up and down of the actuator.

For operating information about the depth command option see page 58.

NOTE:

Over tightening of the sensor arm pivot mounting bolt (fig. 4.26, item 1) may cause the actuator to stall.

IV. PREPARING TO OPERATE

ATTACHING MALE CORN CHOPPERS



FIG 4.27

1. Disconnect the hydraulic hoses from existing heads.
2. Disconnect and remove the head assemblies and, if equipped, the Tasselrol[®]/LS attachments from the tool bar.
3. Attach the male corn chopper to the tool bar.
4. Attach the lower stabilizer arm to the hoist column and male corn chopper (fig. 4.28, item 1).
5. Adjust the support rod so there is approximately two inches of travel on each end (fig. 4.28, item 2).
6. Add weights (fig. 4.28, item 3).

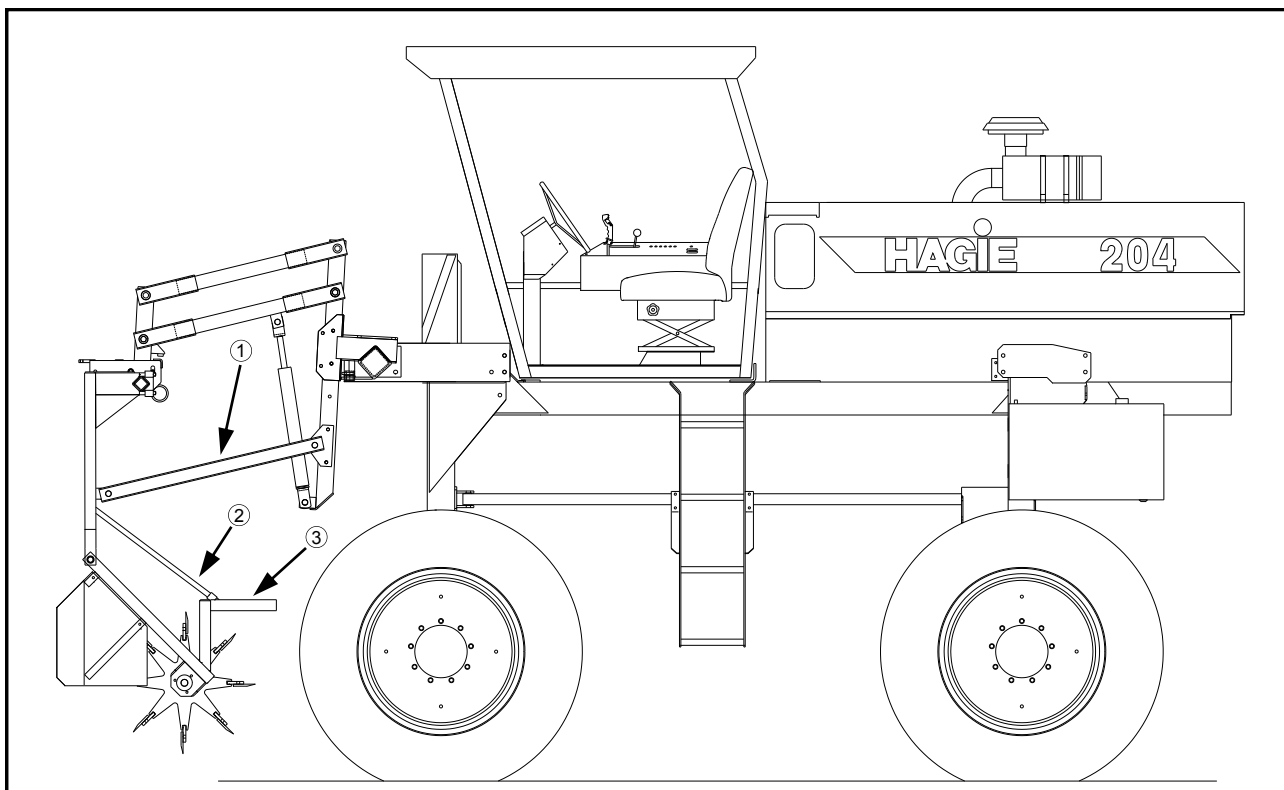

FIG 4.28

IV. PREPARING TO OPERATE

ATTACHING MALE CORN CUTTERS



FIG 4.29

1. Disconnect hydraulic hoses from existing heads.
2. Remove tool bar weldments with heads.
3. Install male corn cutter adapter brackets (4.30, item 1)
4. Install male corn cutter drop tube assembly (4.30, item 2).
5. Connect hydraulic hose to the male corn cutter motor as shown in schematic in HAG-IE 204 SP Parts Manual.

NOTE:

Mounting brackets, case drain assembly, or a hydraulic package may need to be ordered to attach male corn cutters. For further information, contact the Hagie Customer Support Department.

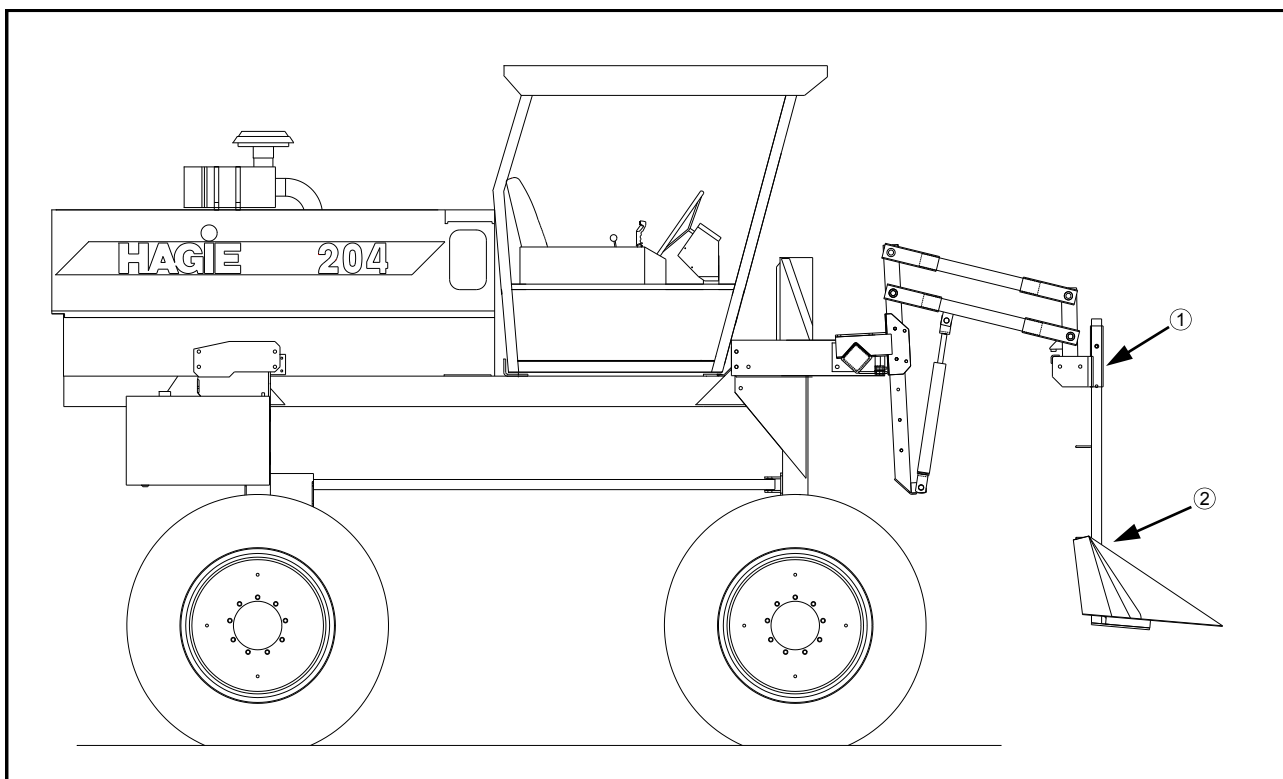

FIG 4.30

SAFETY/
DETAILED IDENTIFICATION DECALS

SPECIFICATIONS

PREPARING TO OPERATE

OPERATING INFORMATION

TRANSPORTING

SERVICE/ MAINTENANCE

STORAGE

TROUBLESHOOTING

LIMITED WARRANTY

INDEX

V. OPERATING INFORMATION

OPERATING THE ENGINE

Pre-operational Checks Page Reference

- | | |
|--|-------|
| 1. Check the engine oil level. Do not operate the engine when oil is below the low mark on dipstick. | 77 |
| 2. Check the coolant level in the radiator and the coolant overflow reservoir. | 79-80 |
| 3. Check the hydraulic oil reservoir level. | 77 |
| 4. Check cooling air intake screens. | 83 |
| 5. Check engine drive belt. | 92 |
| 6. Drain fuel/water separator. | 85 |
| 7. Check the Filter Minder [®] . | 82 |
| 8. Check for any oil or fuel leaks and correct if needed. | |

Starting the Engine

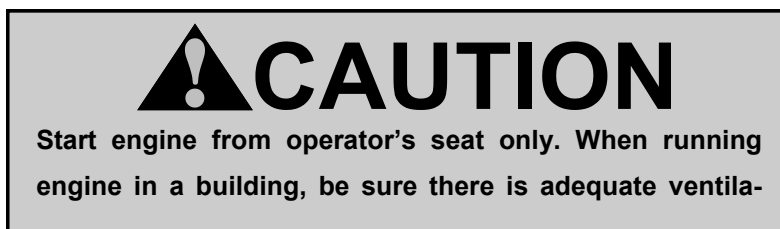

1. Position hydrostatic control lever to "N" (neutral) position.
2. Apply parking brake (see page 41). When starting procedure is complete, release parking brake before moving.
3. Start the engine with the throttle at one-half speed.
4. Turn key to the "ON" position to check instruments.

V. OPERATING INFORMATION

5. Turn the ignition key switch to the start position to engage the starter. If the engine fails to start after 15 seconds, turn key to "OFF", wait one minute and repeat the procedure. If the engine does not start after three attempts, check fuel supply system. Absence of blue or white exhaust smoke during cranking indicates no fuel is being delivered.
6. When engine starts, immediately reduce throttle lever setting to 1/3.
7. Inspect indicator lights and gauges for correct operation. If any lights or gauges do not operate, shut off engine and determine cause.
8. Always allow at least a five minute warm-up period before operating the engine at high RPM. This means the engine must reach operating temperature and oil pressure must stabilize in the normal operating range before it is run faster than an idle (1000 RPM or less). Cold oil may not flow in quantities adequate to prevent pump cavitation

COLD WEATHER STARTING

Using starting fluid without metering equipment:

Spray starting fluid into the air cleaner intake while another person starts the engine. Do not move the sprayer until the other person is off the sprayer and a safe distance away.

 **CAUTION**
Never use starting fluid near an open flame or pre-heater. This could cause an explosion. Do not breathe starting fluid fumes. Starting fluid fumes can be harmful to your health.

NOTE:
Do not use excessive amounts of starting fluid when starting an engine. The use of too much starting fluid will cause engine damage.

 **CAUTION**
When using jumper cables to start engine, make sure to connect the cables in parallel: positive (+) to positive and negative (-) to negative. When using an external electrical source to start the engine, turn the disconnect switch to the "OFF" position. Remove the key before attaching the jumper cables to prevent unintentional starter engage-

| | |
|-----------------------|------------------------------|
| OPERATING INFORMATION | SAFETY/IDENTIFICATION DECALS |
| OPERATING INFORMATION | SPECIFICATIONS |
| OPERATING INFORMATION | PREPARING TO OPERATE |
| OPERATING INFORMATION | TRANSPORTING |
| OPERATING INFORMATION | SERVICE/MAINTENANCE |
| OPERATING INFORMATION | STORAGE |
| OPERATING INFORMATION | TROUBLESHOOTING |
| OPERATING INFORMATION | LIMITED WARRANTY |
| OPERATING INFORMATION | INDEX |

V. OPERATING INFORMATION

HYDROSTATIC SYSTEM

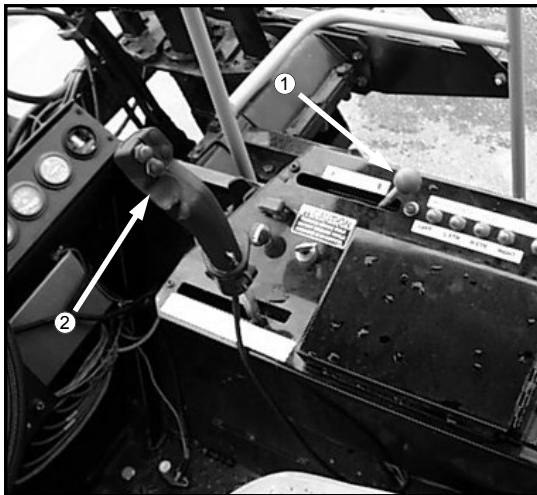

FIG 5.1

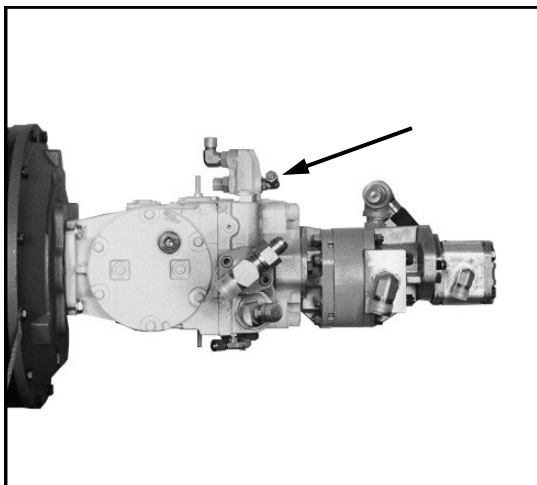

FIG 5.2

Hydrostatic Drive

1. Open the throttle (fig. 5.1, item 1) slowly to the maximum recommended engine speed setting.

NOTE:

Never operate the detasseler at anything less than full recommended throttle.

2. To move forward, slowly push the hydrostatic control lever (fig. 5.1, item 2) forward. The farther the control lever is moved, the faster the detasseler will travel. To stop, slowly pull the lever to the “N” (neutral) position.
3. To reverse the machine, slowly pull the hydrostatic control lever back. To stop, slowly push the lever to the “N” (neutral) position.
4. Before turning off the engine, reduce engine speed and allow the engine to idle at least three minutes.

Charge Pressure

To monitor the closed loop system (hydrostatic pump), install a 500 PSI pressure gauge at the charge pressure port (see fig. 5.2). Start the engine and open the throttle to full RPM. The charge pressure should be between 348 and 365 PSI. If it is below the required pressure, contact the Hagie Customer Support Department.

V. OPERATING INFORMATION

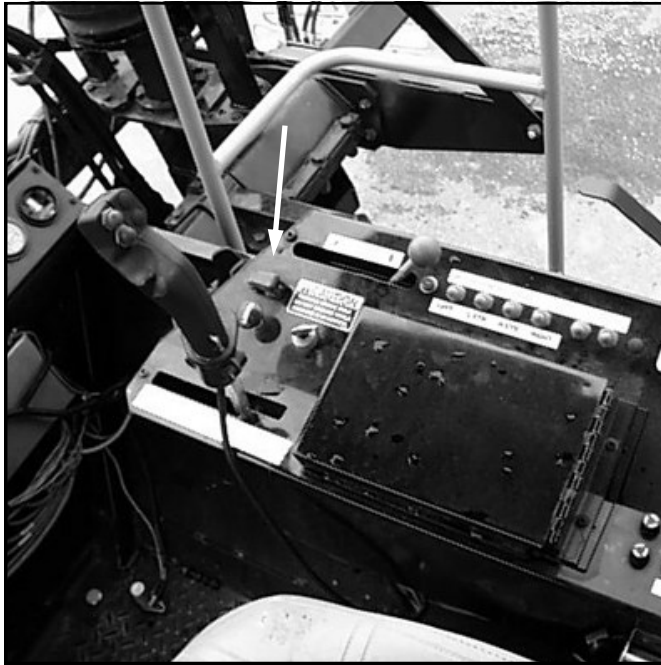
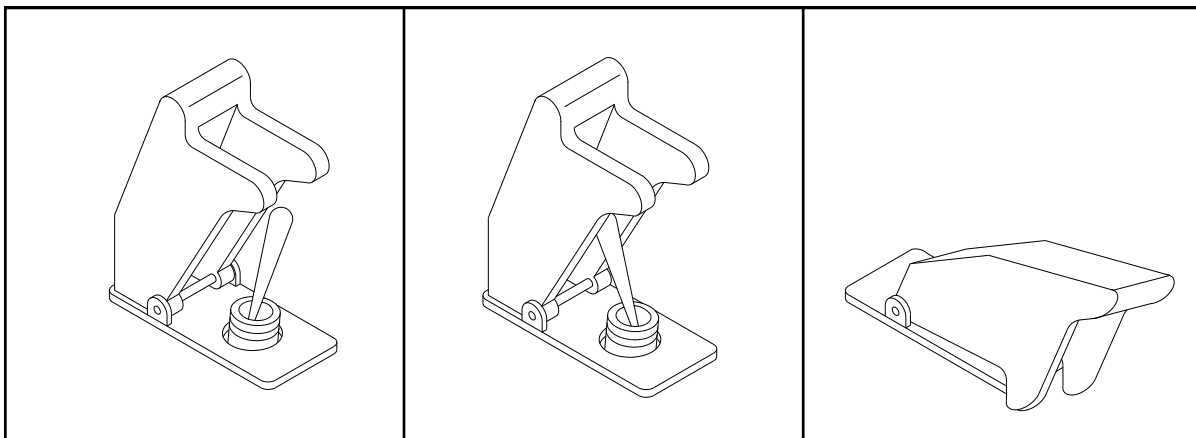
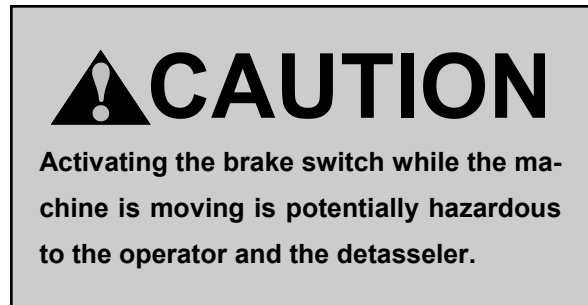

FIG 5.3

Parking Brake

The brakes are controlled by charge pressure. When the engine is shut off or if the charge pressure is below 150 PSI the brakes will become activated. To set the brakes while the engine is running, activate the switch located on the right-hand switch panel (fig. 5.3).

Lift the RED switch cover as shown in figure 5.4A. To engage the brakes, flip the switch forward to the "ON" position as shown in figure 5.4B. To release the brakes, close the RED cover and this in turn will flip the brake switch to the "OFF" position as shown in figure 5.4C. Always return the brake switch to the "OFF" position before moving the detasseler.



A

B

C

FIG 5.4

SAFETY/ DETASSELER IDENTIFICATION DECALS

SPECIFICATIONS

PREPARING TO OPERATE

OPERATING INFORMATION

TRANSPORTING

SERVICE/ MAINTENANCE

STORAGE

TROUBLE SHOOTING

LIMITED WARRANTY

INDEX

V. OPERATING INFORMATION

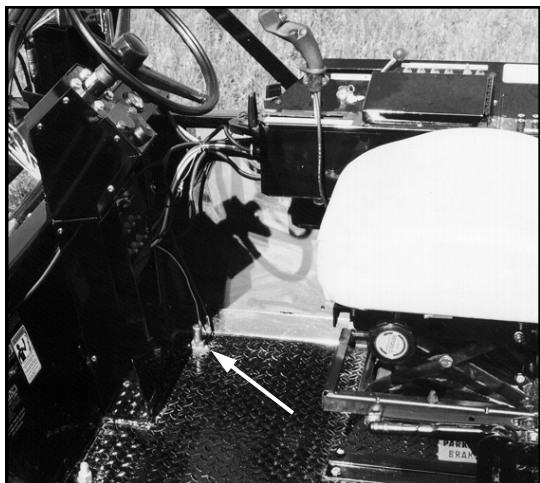

FIG 5.5

Traction Valve

The Model 204 SP detasseler comes equipped with special hydraulic valves for increased traction (one in the front hydraulic loop and one in the rear hydraulic loop). These valves greatly reduce spin-out if muddy conditions prevail, or if wheels lose traction for any reason. The valve in the rear loop is active at all times. The valve in the front loop (fig 5.6) is activated by a switch on the floor in front of the operator's seat (fig. 5.5). When the traction valve is activated an indicator on the instrument panel will light up (fig. 5.7).

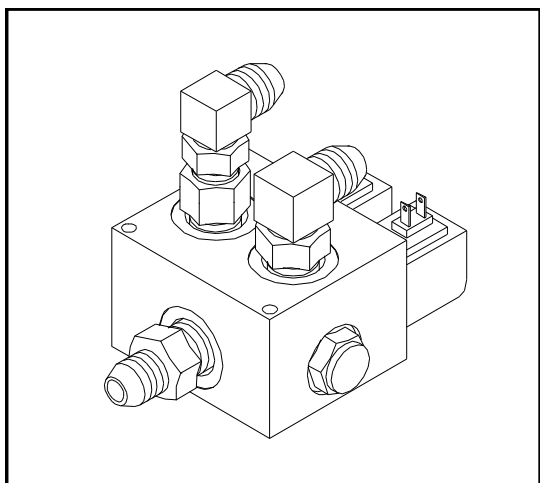

FIG 5.6

NOTE:

To prevent hydraulic loop damage, do not operate the front traction valve continuously. Activate the front traction valve only when needed. Shut the traction valve switch off when clear of problem area.



FIG 5.7

V. OPERATING INFORMATION

HYDRAULIC SYSTEM

The auxiliary hydraulic system is an open type directly mounted behind the heavy duty variable displacement pump. This system consists of dual gear pumps that supply the required hydraulics to operate the full time power steering unit, lift cylinders, and various cutter or pullers.

After supplying each of these systems, the

hydraulic oil is sent to the oil cooler in front of the engine coolant radiator. Here it is cooled and then sent back to the hydraulic oil reservoir.

The front, larger gear pump supplies only the cutters or pullers. The rear, smaller gear pump supplies power steering and the lift cylinders.



FIG 5.8

NOTE:

Immediately shut down engine if low level hydraulic oil light comes on in cab (fig.

CAUTION

DO NOT GO NEAR LEAKS. High pressure oil easily punctures skin causing injury, gangrene, or death. If injured, seek emergency medical help. Immediate surgery is required to remove oil. Do not use finger or skin to check for leaks. Lower load or relieve hydraulic pressure before loosening fittings.

V. OPERATING INFORMATION

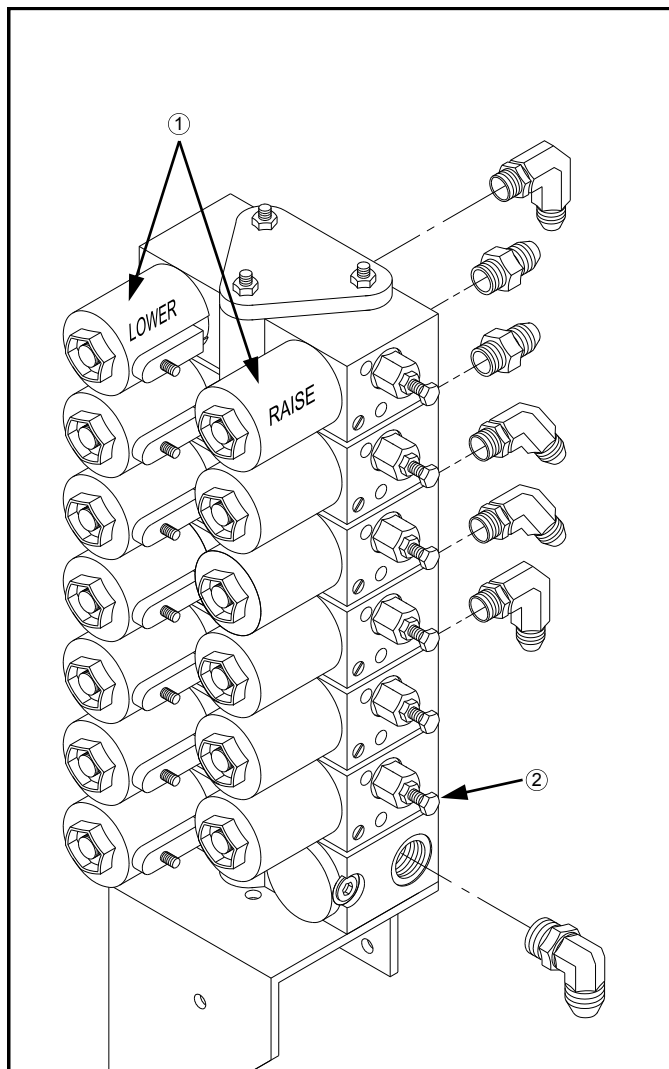

FIG 5.9

Electro-Hydraulic Valve

The electro-hydraulic valve which control the height of the detasseler head lift cylinders is equipped with adjustable raise and lower orifices controlled by independent coils (fig 5.9, item 1). Upon initial setup adjust the orifice screws (fig. 5.9, item 2) as follows, then see page 46 for more precise adjustment:

RAISE – Adjust bolt all the way in and then back it out 2½ turns.

LOWER – Adjust bolt all the way in and then back it out 4 turns.

NOTE:

Over adjustment of raise orifice can cause excessive working pressure.

V. OPERATING INFORMATION

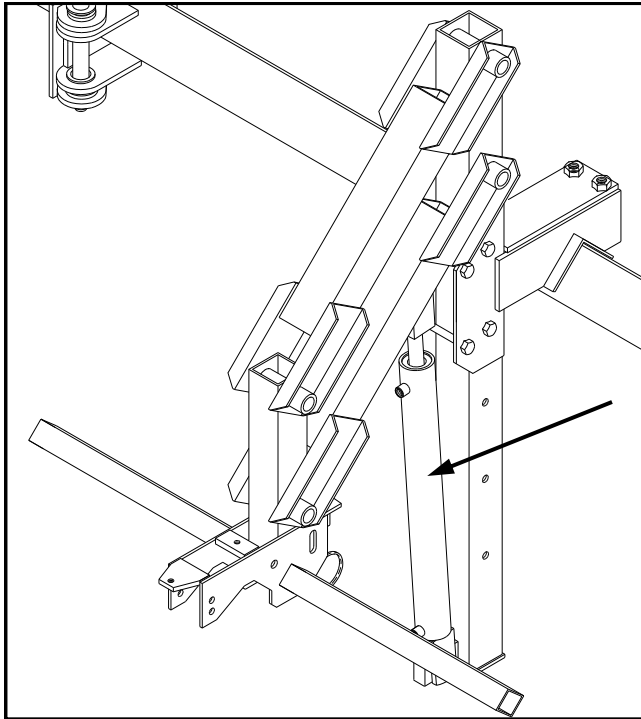

FIG 5.10

Lift Cylinders

To adjust the height of each detasseling head assembly, cylinders mounted on each lift unit (fig. 5.10) are connected to a console-mounted lift control (fig. 5.11). The controls are either switchable from manual to automatic or manual only. The manual control box is used when the detasseler is not equipped with the Tasselrol®/LS system.

For information about operating or adjusting parameters in the Tasselrol®/LS automatic lift controls see pages 48-56.

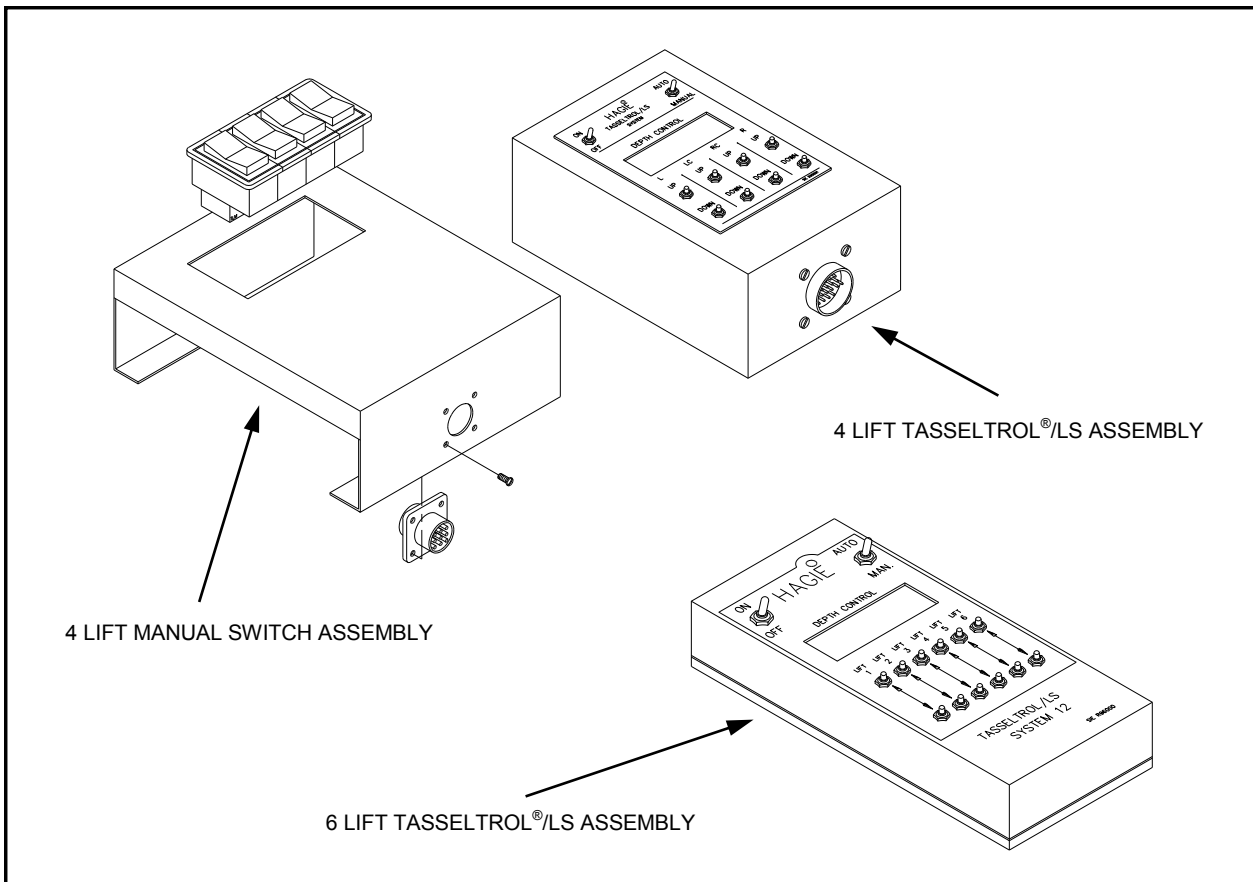

FIG 5.11

OPERATING INFORMATION

PREPARING TO OPERATE

SPECIFICATIONS

DETASSELER IDENTIFICATION DECALS

SAFETY

INDEX

WARRANTY/SHOOTING

STORAGE

SERVICE/MAINTENANCE

TRANSPORTING

V. OPERATING INFORMATION



FIG 5.12

NOTE:

Over adjustment of raise orifice can cause excessive working pressure.

Setting Each Lift Assembly

Install a 3,000 PSI pressure gauge on the inlet of the electro-hydraulic valve (fig. 5.13, item 1). With the engine running at an idle, raise each unit one at a time with the Tasseltrol® box while in “MANUAL” mode. Observe the pressure. Adjust each lift cylinder to 1000 PSI.

To increase the pressure of a given lift cylinder, turn the adjustable screw (fig. 5.13, item 2) on the raise orifice clockwise. To decrease the pressure of a given cylinder, turn the adjustable orifice screw counter-clockwise.

After each unit has been adjusted to 1000 PSI, test the settings by turning the Tasseltrol® box to “AUTO” and activate the “ALL UP” switch (fig. 5.12) on the hydrostatic control handle (“ALL UP” dwell should be set at 20 seconds – see page 51). At this time all units should lift together.

Adjust each lower orifice as outlined on page 44.

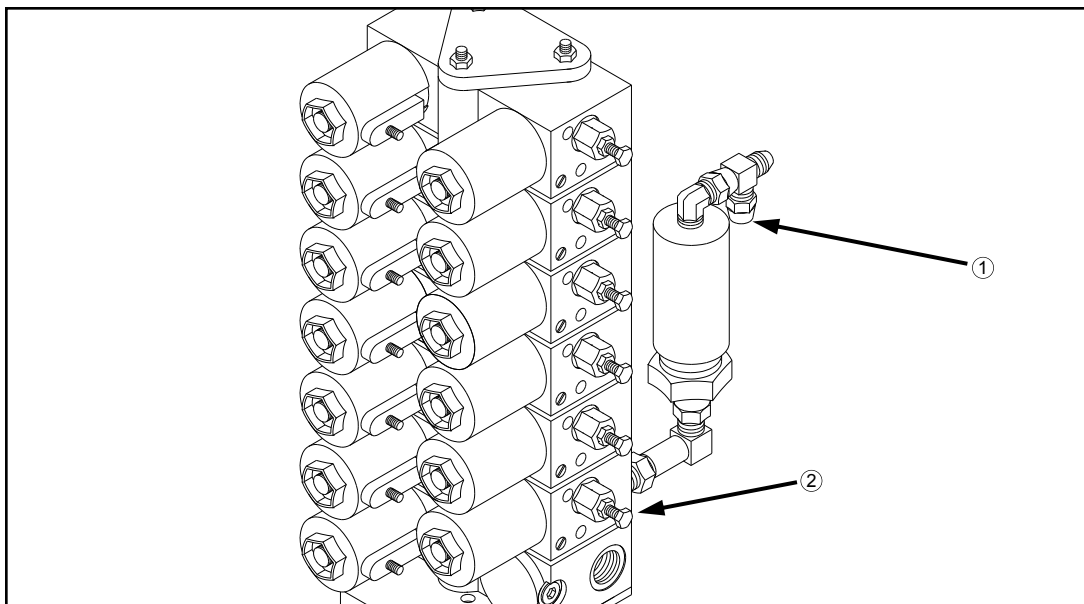

FIG 5.13

V. OPERATING INFORMATION

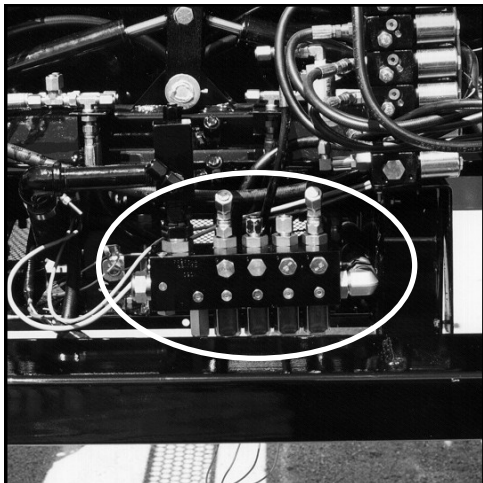

FIG 5.14

Detasseling Heads

The hydraulic motors on the detasseling heads (fig. 5.16) are turned on and off with a row of switches mounted on the control panel to the right of the operator's seat (fig. 5.15). To open the solenoid on any of the motor control valves (fig. 5.14) which activate the motors, flip the corresponding switch(es) away from the operator's seat. To shut any or all motors off, flip the corresponding switch(es) toward the operator.

Each motor control valve contains a .182 inch orifice disc that restricts hydraulic flow to the hydraulic motors so they don't overspeed and become damaged.

Activate hydraulic motors while engine speed is at an idle, then increase engine RPM to operating speed.

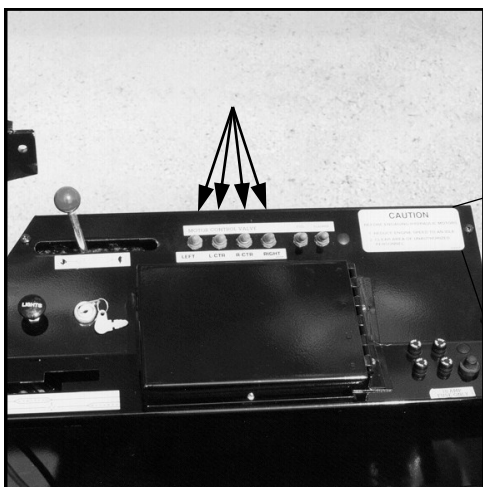

FIG 5.15

CAUTION

BEFORE ENGAGING HYDRAULIC MOTORS

1. REDUCE ENGINE SPEED TO AN IDLE
2. CLEAR AREA OF UNAUTHORIZED PERSONNEL

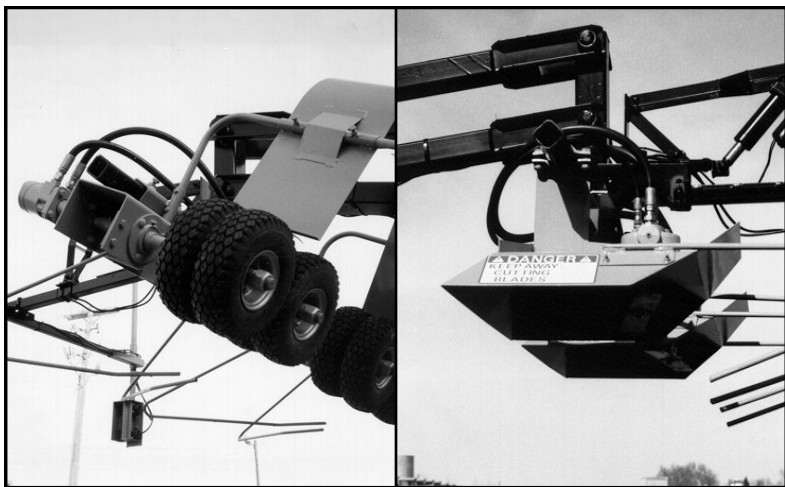

FIG 5.16

CAUTION

DO NOT operate the hydraulic motors on detasseling heads without .182 inch orifices in place under each solenoid coil.

| | |
|----------------|--------------------------|
| SAFETY/ | DETASSLER IDENTIFICATION |
| SPECIFICATIONS | DECALS |
| PREPARING | TO OPERATE |
| OPERATING | INFORMATION |
| TRANSPORTING | |
| SERVICE/ | MAINTENANCE |
| STORAGE | |
| TROUBLE | SHOOTING |
| LIMITED | WARRANTY |
| INDEX | |

V. OPERATING INFORMATION

SETTING UP THE TASSELTRON[®]/LS SYSTEM

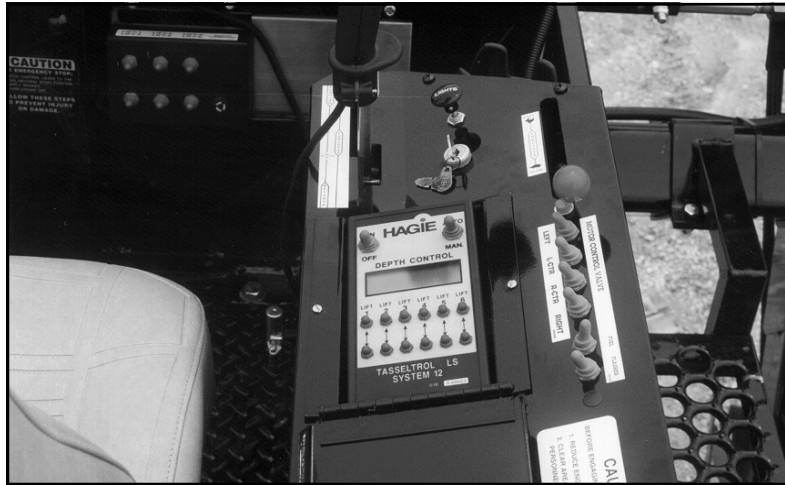

FIG 5.17

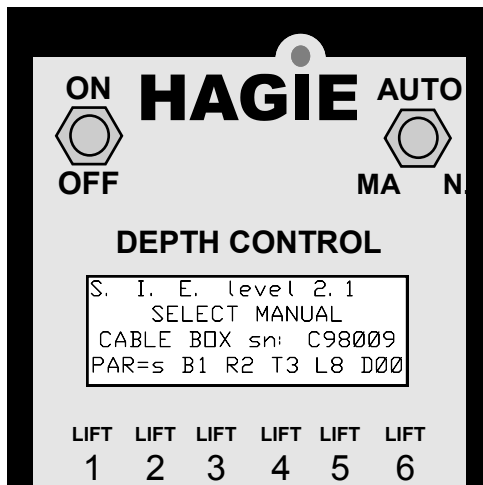

FIG 5.18

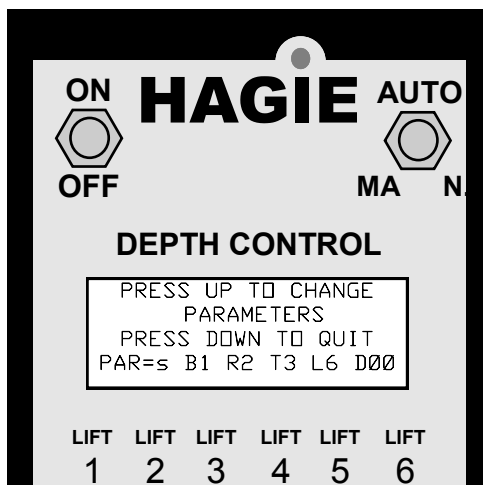

FIG 5.19

The control box (fig. 5.17) has three programmable parameters and each has four different value settings. Your programmable control box is factory preset with the following parameter defaults:

BOTTOM PARAMETER – B1 See page 54 to reprogram the bottom parameter.

RESPONSE PARAMETER – R2 See page 52 to reprogram the response parameter.

TOP PARAMETER – T3 See page 53 to reprogram the top parameter.

These parameters will always be displayed until the control box is reprogrammed. Once reprogrammed, the values for the parameters will appear in the window of the control box. The new parameters will maintain their value for approximately a two week period. If the unit is not used within this time frame, the parameters will automatically return to the normal settings.

To program the unit, first select the response parameter (page 52). If further adjustment is required for top and/or bottom parameters, see pages 53 and 54.

V. OPERATING INFORMATION

OPERATING THE TASSELTROL®/LS CONTROL

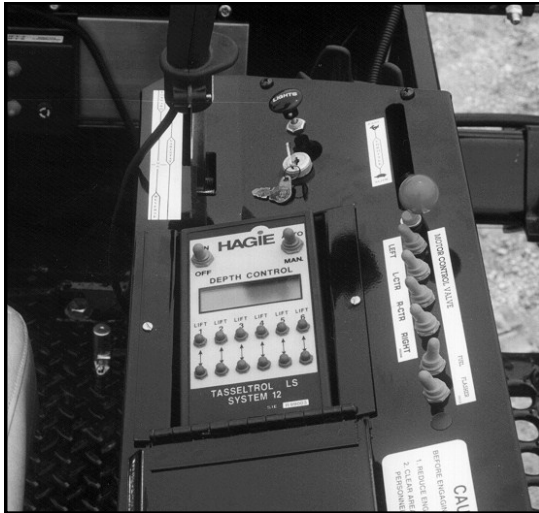

FIG 5.20

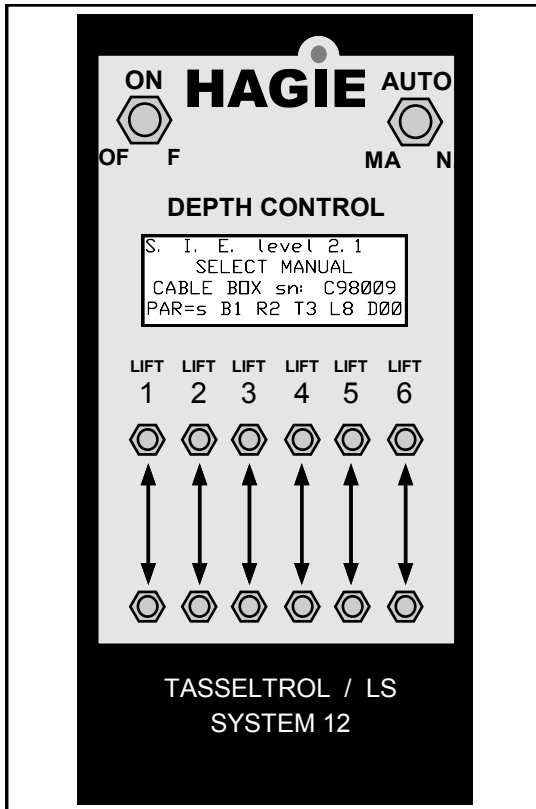

FIG 5.21

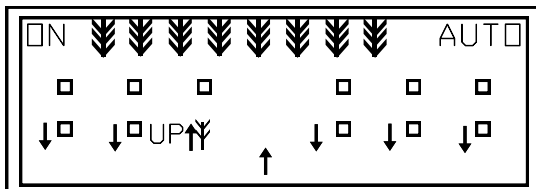

FIG 5.22

To use the control box with its normal parameter setting, use the following procedures. To adjust the given parameters, see pages 52-54.

1. From the operator's seat, turn the ignition to the "ON" position.
2. Turn the control box power switch to the "ON" position.
3. Turn the "AUTO/MANUAL" switch to "MANUAL." At this time the display will read "MANUAL" in addition to other information identifying the control box.
4. Press the individual row switches for up and down movement. An arrow in the display will indicate direction of each lift assembly. "P" indicates pressure - "UP" only.
5. If the "AUTO/MANUAL" switch is left in the "AUTO" position when the unit is first started, the display will tell you to select "MANUAL." After you have selected "MANUAL" switch back to the "AUTO" position.
6. To raise and hold one or more units during operation, press the desired "UP" switch, select "MANUAL" and back to "AUTO." This will hold the unit up in position. To re-activate the lift, switch to "MANUAL" and back to "AUTO."
7. To override the system, press the desired "UP" switch to raise the attachment. When the switch is released, the system will go back into the "AUTO" mode.
8. If the ignition is left on and the "AUTO/MANUAL" switch is left in the "AUTO" position, the down coils on the electro-hydraulic valve will lose power after 45 seconds. To re-activate, move the "AUTO/MANUAL" switch from "AUTO" to "MANUAL" and back to "AUTO."
9. The control box is set up with a feature so that if a unit loses contact during operation in the "AUTO" mode, the unit will automatically rise. If this should happen, switch

SAFETY / IDENTIFICATION DECALS
 SPECIFICATIONS
 PREPARING TO OPERATE
 OPERATING INFORMATION
 TRANSPORTING
 SERVICE / MAINTENANCE
 STORAGE
 TROUBLE SHOOTING
 LIMITED WARRANTY
 INDEX

V. OPERATING INFORMATION



FIG 5.23



FIG 5.24

SHORT CORN OPERATION

When operating the LS system, always select “MANUAL” when first entering the field. Once you have maintained your operating speed and the cutting and/or pulling depth, select “AUTO.” When you come to an area where the corn is very short, such as a low spot in the field, you may want to switch to the “MANUAL” position until you reach taller corn.

Always switch to the “MANUAL” position before you reach the end rows (fig. 5.23). This will allow the cutter or puller heads to maintain their cutting or pulling height when re-entering the field (fig. 5.24), then you may switch back to “AUTO.”

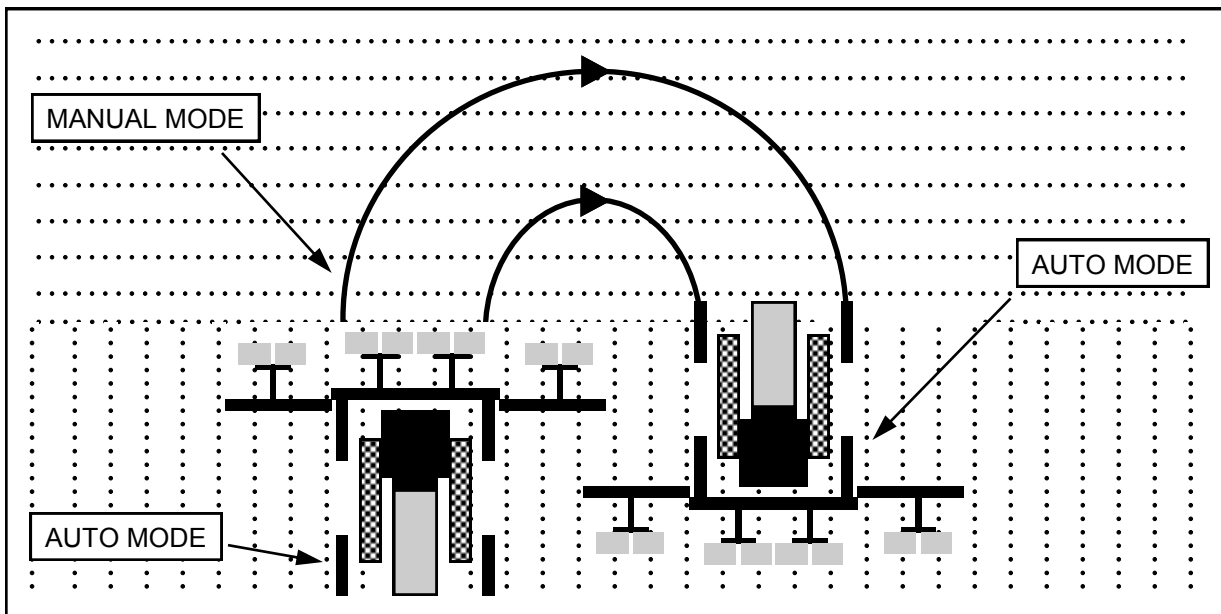

FIG 5.25

V. OPERATING INFORMATION



FIG 5.26

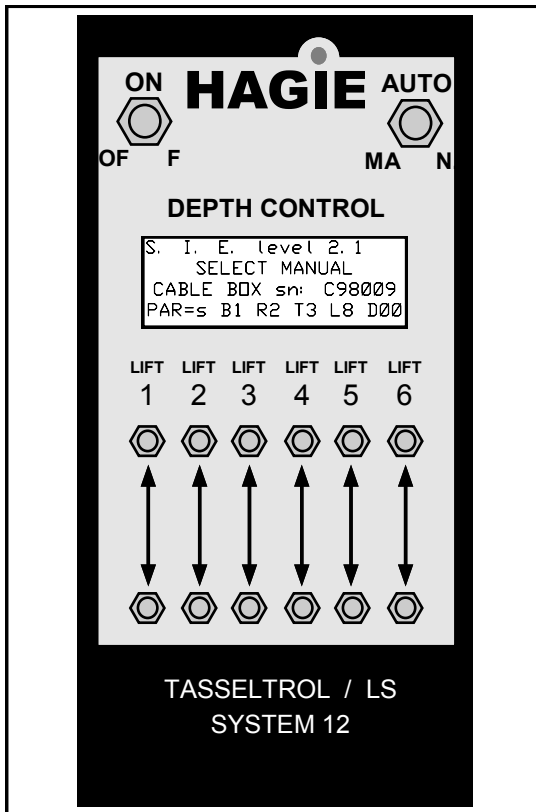

FIG 5.27

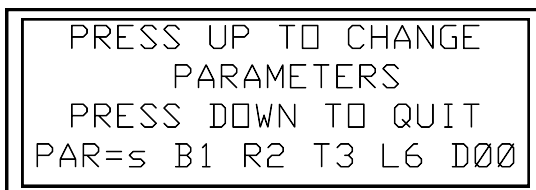

FIG 5.28

“ALL UP” and “ALL HOLD” Function

This function can be used to raise or lower all row units at the same time. The switches to control this option are located on the hydrostat control handle (5.26). All the row units will move up when the red switch (5.26, item 1) is activated and will lower when the green switch (5.26, item 2) is activated.

The parameters for dwell on the up move can be set to 0, 5, 10, 15, 20, or 25 seconds. The heads will move up in this amount of time without having to hold the red switch in. All heads will hold this position when the parameter is reached. To resume automatic depth control, activate the green switch.

To program the “ALL UP” and “ALL HOLD” function:

1. Put the “AUTO/MANUAL” switch to “AUTO.”
2. Put the “ON/OFF” switch to “ON.”
3. Press the “UP” button under “PAR”.
4. Press the “UP” button under “MISC” (4 lift only. If 6 lift, skip to step 5.)
5. Press the “UP” button under “D” to set the dwell time.
6. After selecting one of the dwell time choices, press any of the down switches.
7. To escape the parameter mode, press down a second time to return to the original screen (this will save the information on a 4 lift control; to save on a 6 lift control, switch the AUTO/MANUAL toggle to MANUAL).

DETASSELER SAFETY / IDENTIFICATION DECALS
 SPECIFICATIONS
 PREPARING TO OPERATE
 OPERATING INFORMATION
 TRANSPORTING
 SERVICE / MAINTENANCE
 STORAGE
 TROUBLE SHOOTING
 LIMITED WARRANTY
 INDEX

V. OPERATING INFORMATION

TASSELTROL[®] RESPONSE PARAMETER

The response parameter is used to adjust the response time of both photocells. How quickly the down motion starts when no corn is detected by either the top or bottom cells, and how quickly the up motion is stopped when corn is no longer detected by the top cell, can be changed by selecting R1, R2, R3, or R4. More corrections will occur with R1 selected, and fewer corrections with R4 selected. The normal or default value for this parameter is R2, but can be set to any desired value.

Use the response parameter to adjust overall correction activity and to compensate for ground speed. If the pullers are moving too quickly and frequently, the response parameter can be increased toward R4. If the pullers are too slow to respond to changes in the corn depth, increase the parameters

toward R1. Generally this parameter can be left at R2.

To display the response parameter, select "AUTO" and turn the control box power on. Wait three seconds for the "SELECT MANUAL" message, press the "UP" button under "PAR". Now press the "UP" button under the "R" value.

1. The active value of the parameter is indicated by it blinking on and off, while the other three choices are displayed continuously.
2. To select a new value for the parameter, press the "UP" button under the desired choice.
3. After selecting one of the four choices, press any of the "DOWN" buttons to escape this parameter.
4. To save new values and escape the parameter mode, press "DOWN" a second time and switch "AUTO/MANUAL" toggle to "MANUAL."

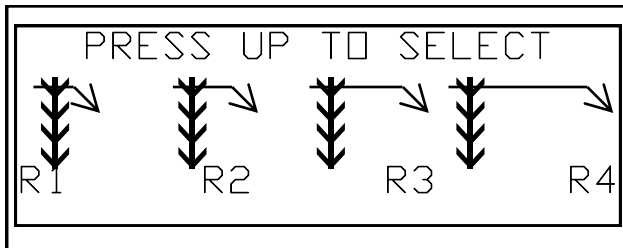
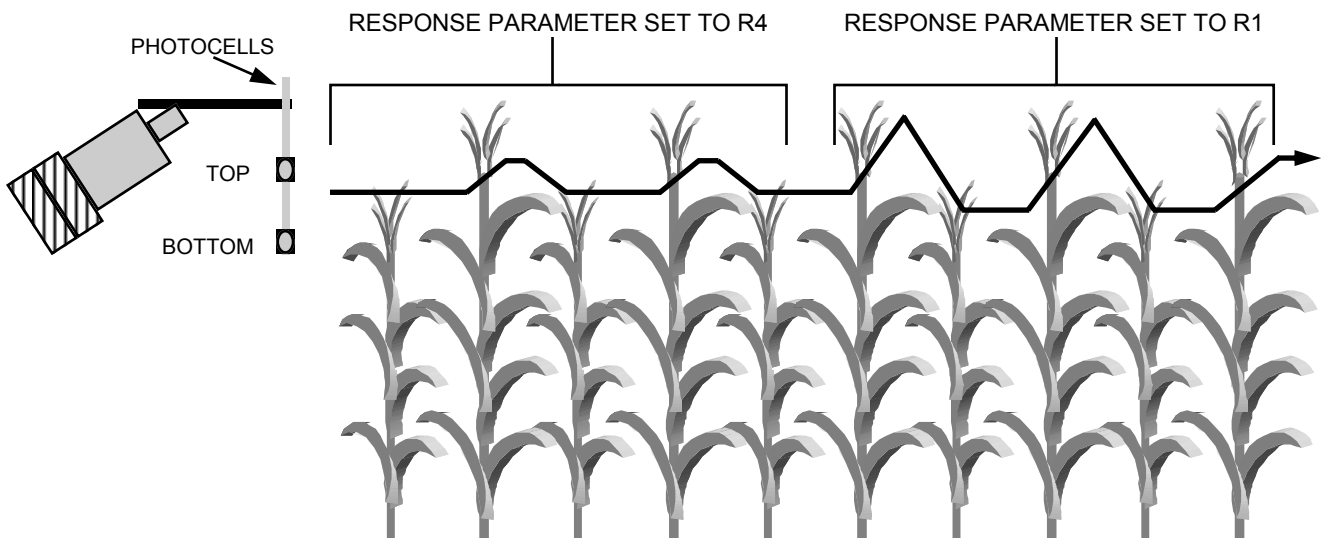

FIG 5.29

NOTE:
See page 57 for more information regarding the LS photolights.



V. OPERATING INFORMATION

TASSELTROL® TOP PARAMETER

The top parameter is used to adjust the sensitivity of the top photocell. The top photocell starts the up motion when its lights path is blocked by corn. How much corn it has to see before starting the up move can be changed by selecting one of the four values T1, T2, T3, or T4. With T1 selected, more corn is required to start an up move. The normal or default value for this parameter is T3, but can be set to any desired value.

If the pullers move up too easily when a taller stalk of corn passes, increase the parameter toward T4. If the pullers stay deep too long when taller corn passes, decrease the parameter toward T1. Generally this parameter can be left at T3.

To display the top parameter, select "AUTO" and turn the control box power on. Wait three sec-

onds for the "SELECT MANUAL" message. Press the "UP" button under "PAR". Now press the "UP" button under the "T" value.

1. The active value of the parameter is indicated by it blinking on and off, while the other three choices are displayed continuously.
2. To select a new value for the parameter, press the "UP" button under the desired choice.
3. After selecting one of the four choices, press any of the "DOWN" buttons to escape this parameter.
4. To save new values and escape the parameter mode, press "DOWN" a second time and switch "AUTO/MANUAL" toggle to "MANUAL."

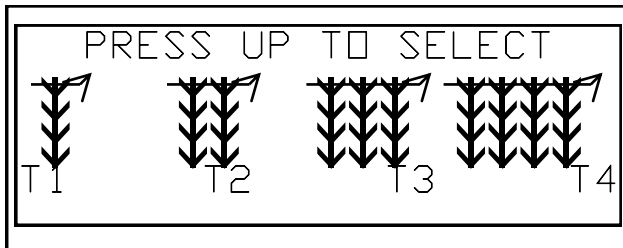
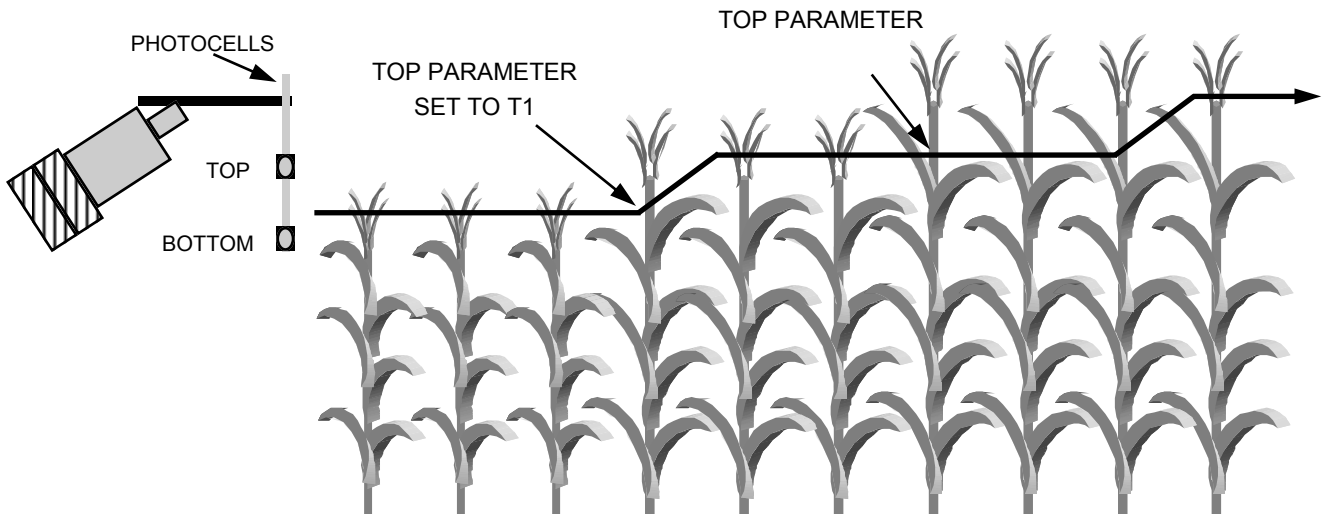

FIG 5.30

NOTE:
See page 57 for more information regarding the LS photolights.



| | |
|----------------|----------------|
| SAFETY/ | IDENTIFICATION |
| DETASSEL | DECALS |
| SPECIFICATIONS | |
| PREPARING | OPERATE |
| OPERATING | INFORMATION |
| TRANSPORTING | |
| SERVICE/ | MAINTENANCE |
| STORAGE | |
| TROUBLE | SHOOTING |
| LIMITED | WARRANTY |
| INDEX | |

V. OPERATING INFORMATION

TASSELTROL[®] BOTTOM PARAMETER

The bottom parameter is used to adjust the sensitivity of the bottom photocell. The bottom photocell stops the down motion when its light is blocked by corn. How much corn it has to see before stopping the down move can be changed by selecting one of the four values B1, B2, B3, or B4. With B1 selected the down move will stop as soon as corn is detected. With B4 selected the down move will continue a little longer. The normal or default value for this parameter is B1, but can be set to any desired value.

If the pullers run too shallow after moving down into shorter corn, increase the parameter toward T4. If the pullers move too deep when going into shorter corn or oscillate between the top and bot-

tom photocells, decrease the parameter toward B1. Generally this parameter can be left at B1.

To display the bottom parameter, select "AUTO" and turn the control box power on. Wait three seconds for the "SELECT MANUAL" message. Press the "UP" button under "PAR". Now press the "UP" button under the "B" value.

1. The active value of the parameter is indicated by it blinking on and off, while the other three choices are displayed continuously.
2. To select a new value for the parameter, press the "UP" button under the desired choice.
3. After selecting one of the four choices, press any of the "DOWN" buttons to escape this parameter.
4. To save new values and escape the parameter mode, press "DOWN" a second time and switch "AUTO/MANUAL" toggle to "MANUAL."

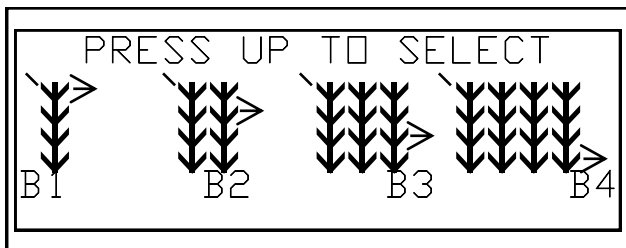
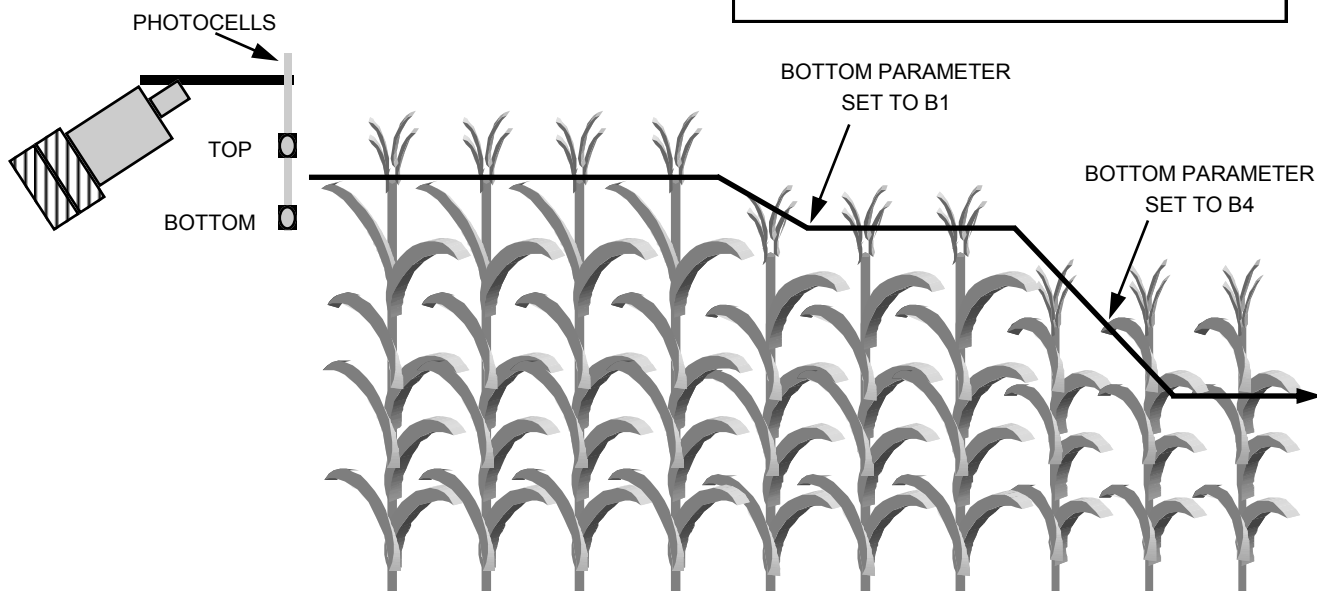

FIG 5.31

NOTE:
See page 57 for more information regarding the LS photolights.



V. OPERATING INFORMATION

Four-Lift TASSELTROL® Display Screen Quick Reference Chart

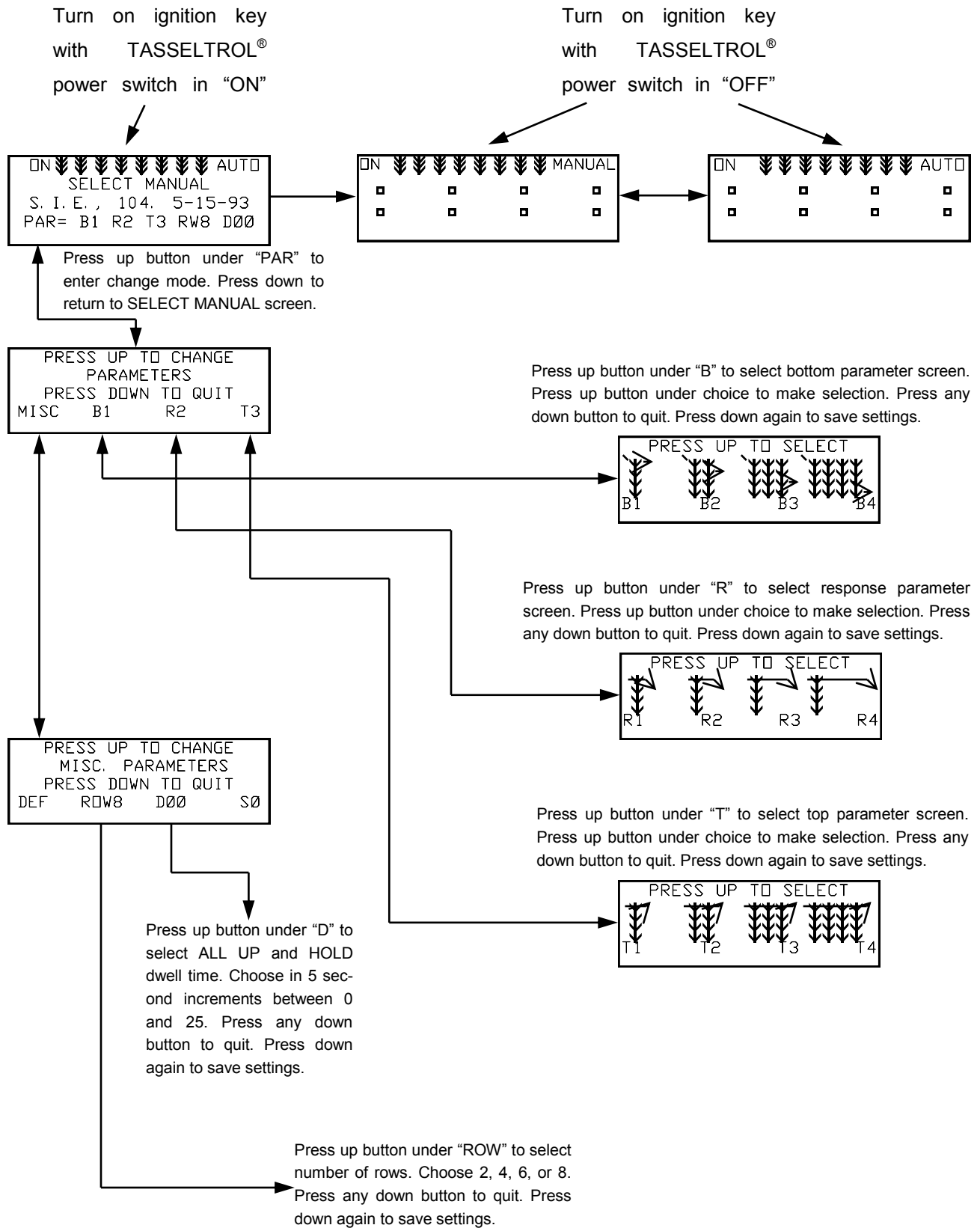

| | | | |
|-----------------------|----------------------|---------------------|---------------------------------------|
| OPERATING INFORMATION | PREPARING TO OPERATE | SPECIFICATIONS | DETAILED SAFETY/IDENTIFICATION DECALS |
| OPERATING INFORMATION | TRANSPORTING | SERVICE/MAINTENANCE | TROUBLE SHOOTING |
| OPERATING INFORMATION | STORAGE | LIMITED WARRANTY | INDEX |

V. OPERATING INFORMATION

Six-Lift TASSELTROL® Display Screen Quick Reference Chart

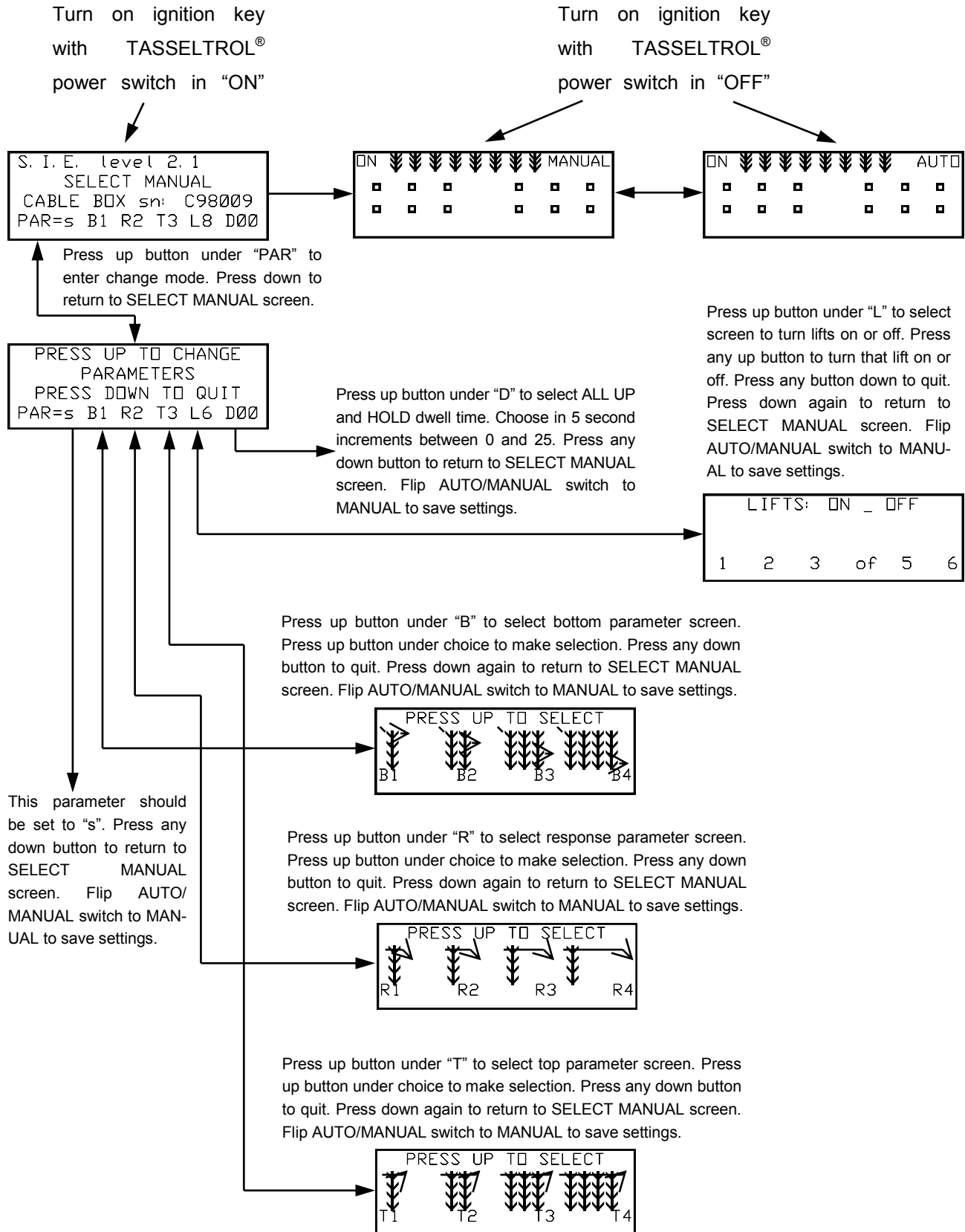

V. OPERATING INFORMATION

LS PHOTOLIGHT INDICATORS

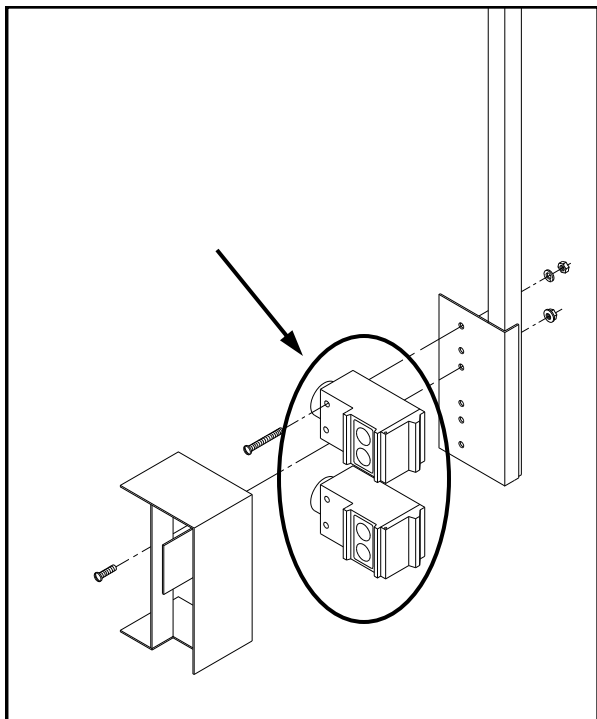

FIG 5.32

The upper and lower LS photolights (fig. 5.32) have L.E.D. lights (fig. 5.33) that indicate their operational status.

LT/DK SWITCH – Light/Dark switch on photolight (fig. 5.33, item 1) changes the activated condition of green L.E.D. (see below) from *ON* (“LT”) to *OFF* (“DK”). Switch does not affect the functional operation of the light, only how it is displayed. Switch should be set to “LT”.

SENSITIVITY ADJUSTMENT SCREW – Sensitivity adjustment screw (fig. 5.33, item 2) should always be set to maximum.

YELLOW L.E.D. – Yellow L.E.D. (fig. 5.33, item 3) indicates power on.

GREEN L.E.D. – Green L.E.D. (fig. 5.33, item 4) indicates output energized (sending a signal to Tassel-tron[®] box, opening the raise or lower stack valve).

RED L.E.D. – Red L.E.D. (fig. 5.33, item 5) indicates photolight is receiving reflected signal.

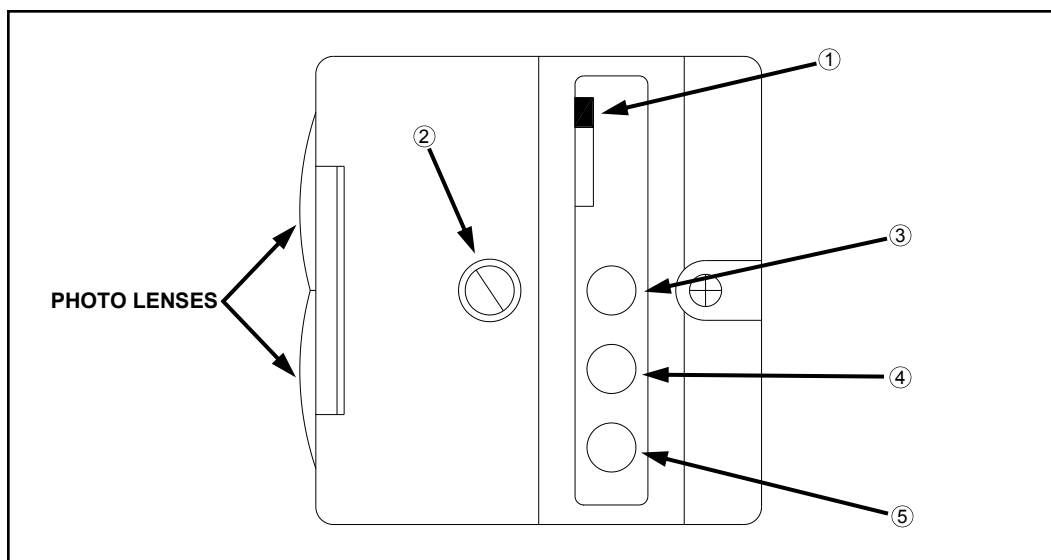

FIG 5.33

V. OPERATING INFORMATION

DEPTH COMMAND

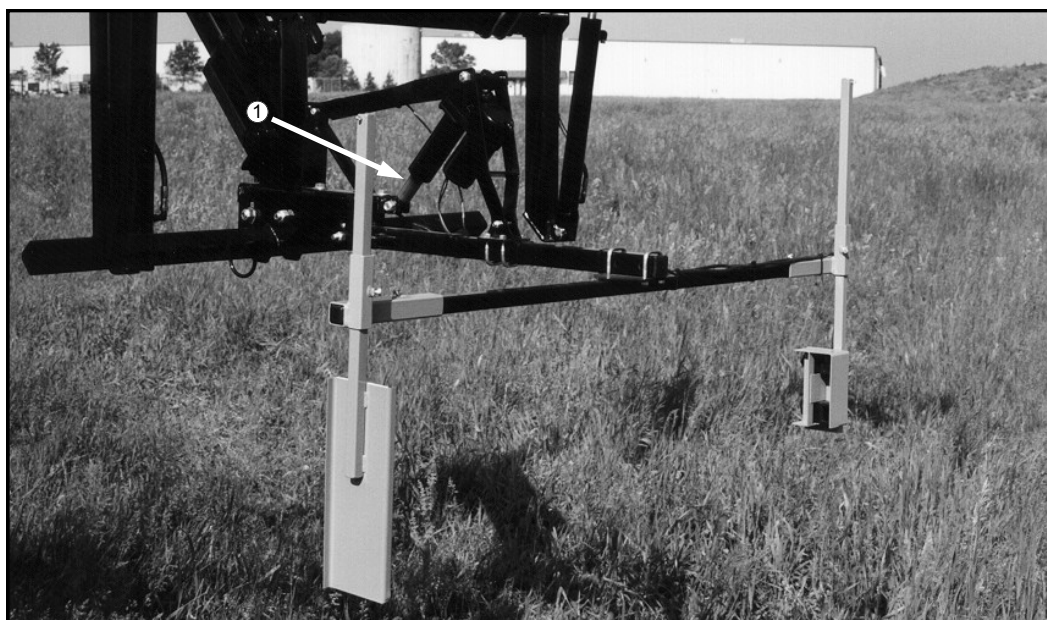

FIG 5.34



FIG 5.35

The Hagie 204 SP comes available with optional adjustable DEPTH COMMAND (fig. 5.34). This allows the operator to adjust the depth of the LS system from the cab. The switches are located to the right of the steering column (fig. 5.35).

To lower the cutting or pulling height, select the appropriate switch and push down. This will extend the actuator (fig. 5.34, item 1), raising the LS system, which in turn lowers the cutting or pulling height. To raise the cutting height, lower the actuator by pushing the appropriate switch up.

NOTE:

DO NOT operate more than two actuators at one single time. This may blow the fuse located on the switch panel (fig. 5.35). For more information on the DEPTH COMMAND fuse, see page 90.

V. OPERATING INFORMATION

GAUGE PANEL

Speedometer/Tachometer - (fig. 5.37, item 1)
Unit will display either engine RPM or speed of travel depending on operator's selection. See pages 60-61 for more information on the speedometer/tachometer.

Water Temperature - (fig. 5.37, item 2) The water temperature gauge monitors the engine cooling system. A "RED" indicator light alerts the operator of unsafe operating temperatures.

Engine Oil Pressure - (fig. 5.37, item 3) The oil pressure gauge monitors pressure of the engine lubricating system. A "RED" indicator light alerts the operator of low level operation.



FIG 5.36

Fuel Gauge - (fig. 5.37, item 4) The fuel gauge measures the amount of fuel in either fuel tank, depending on the tank selected with the fuel switch. A "YELLOW" indicator light alerts operator of low level operation.

Volt Meter - (fig. 5.37, item 5) The volt meter measures voltage from the alternator on the diesel engine. A "RED" indicator light will alert the operator if the system is operating either too low or too high.

Hour Meter - (fig. 5.37, item 6) The hour meter progressively records elapsed time of detasseler operation. It is useful for determining service intervals.

Filter Minder - (fig. 5.37, item 7) See page 82 for information regarding the air filter monitoring system.

NOTE:
Immediately reduce engine speed and shut off ignition if any of the above "RED" indicator lights illuminate. Determine cause and correct before continuing operation.

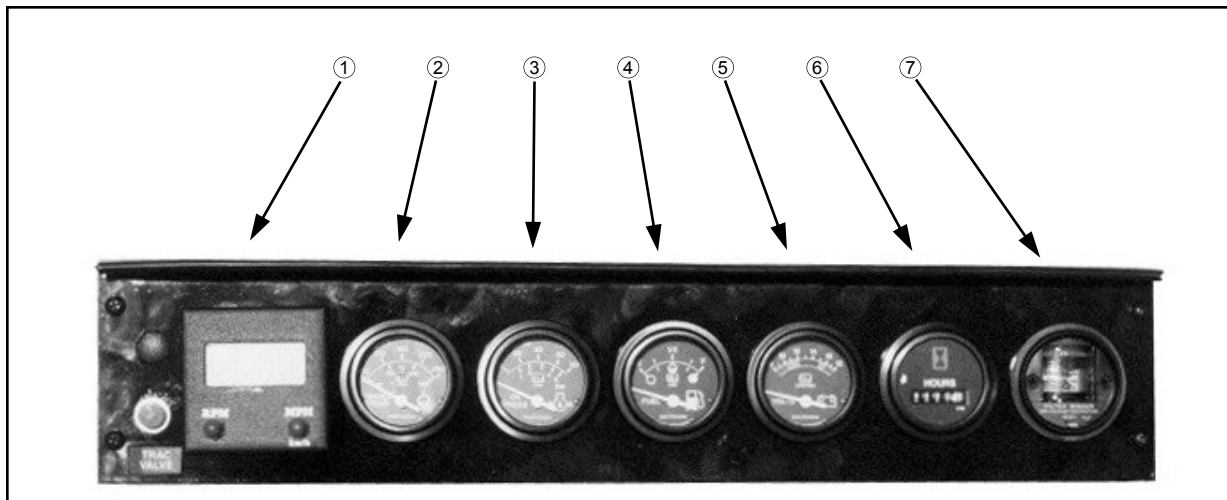

FIG 5.37

SAFETY/
DETAASLER IDENTIFICATION
DECALS
SPECIFICATIONS
PREPARING
TO OPERATE
OPERATING
INFORMATION
TRANSPORTING
SERVICE/
MAINTENANCE
STORAGE
TROUBLE
SHOOTING
LIMITED
WARRANTY
INDEX

V. OPERATING INFORMATION

SPEEDOMETER/TACHOMETER

The speed/tach unit is programmable with a digital read-out indicating MPH or RPM. The parameters have been factory set.

Turn the ignition key to the "ON" position. The display will show "0000", which indicates RPM. Press the MPH button; the readout will display "00.0" which indicates MPH.

To check the parameter settings, press the desired button and hold until four "8's" are shown, then release (fig. 5.38B). The parameter setting will

be displayed for four seconds.

PARAMETER SETTING

RPM 357
 MPH (11.2-38 tire) - 119.2

To change or re-enter the parameters, press the desired button and hold in until the four "8's" are displayed. Release the button and the parameter setting will appear. If you want to increase the setting, press the RPM button. To decrease, press the MPH button.

PROGRAMMING MPH - To program the MPH, use the formula from figure 5.39. Example (11.2-38 tires): **168** divided by front tire static load radius of **26.2** inches times Torque Hub® reduction of **18.25** times number of speedometer ring pick-up sensors on sensor disc of **43** equals **5031.9**; **5031.9** divided into **600,000** equals parameter setting of **119.2**.

This parameter setting should be checked when you receive your detasseler.

ADDITIONAL PARAMETERS – To access the miscellaneous parameters screen (fig. 5.38C), hold down both buttons at the same time until the screen with four "8's" appears.

Use the RPM buttons to scroll the parameter settings (P3 = power-up display, P4 = signal tracking speed, P5 = input device). Use the MPH button to change the setting of the displayed parameter (either 0 or 1).

See the next page for more information.

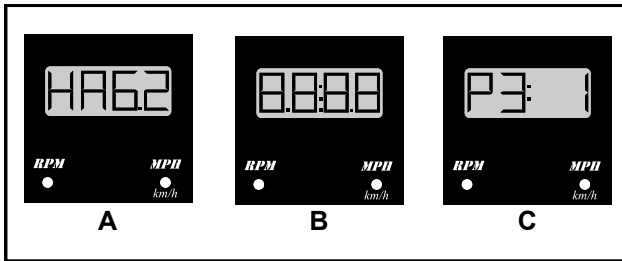

FIG 5.38

| | |
|------------------------------|---------------------------------------|
| A = Torque-Hub® reduction | $\frac{168 \times A \times B}{C} = X$ |
| B = speedometer ring pick-up | |
| C = tire static load radius | |
| Y = MPH parameter setting | $\frac{600,000}{X} = Y$ |

FIG 5.39

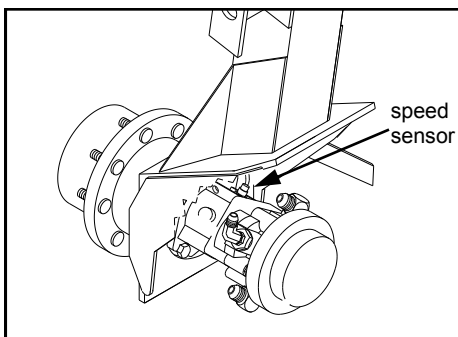
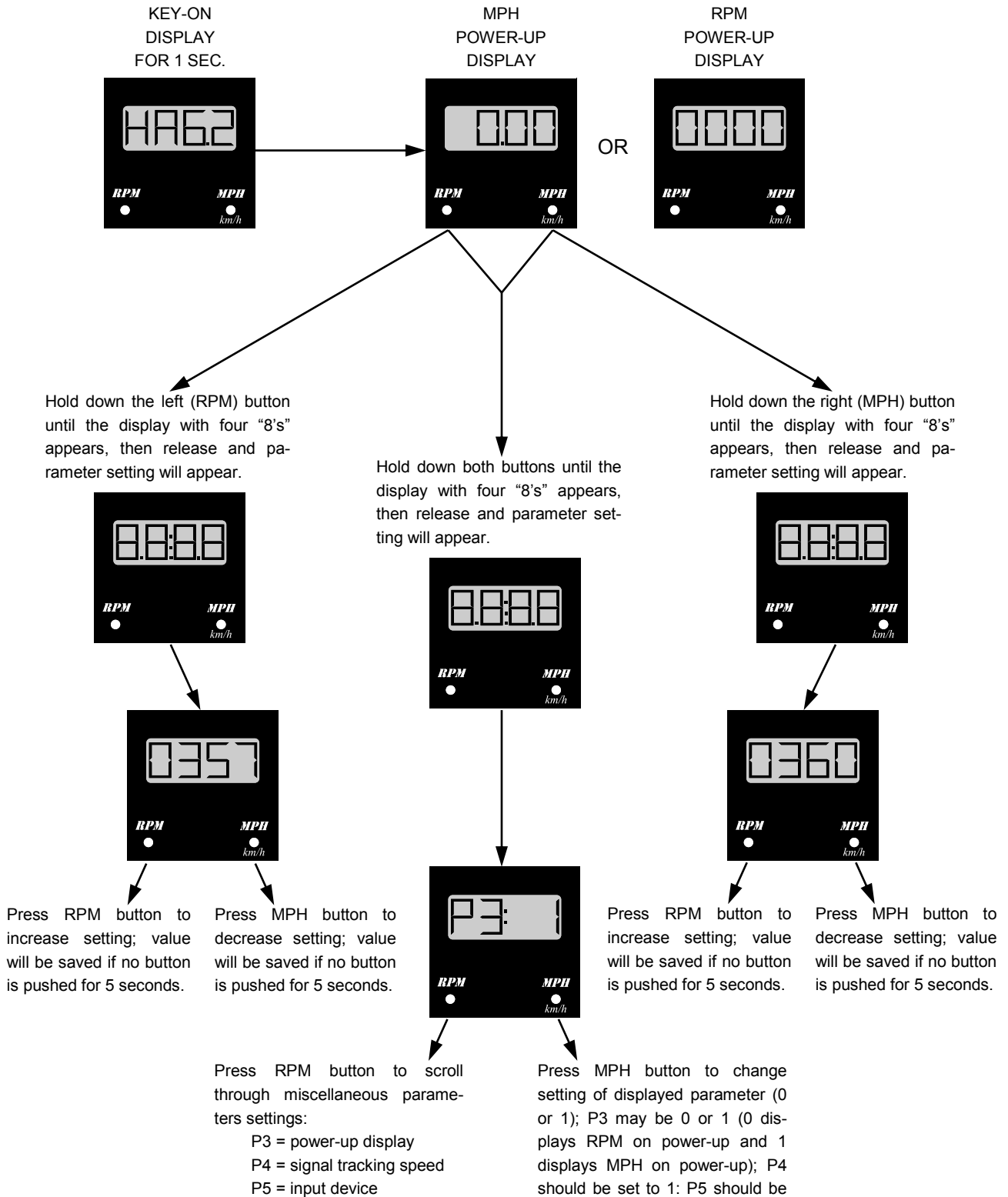

FIG 5.40

V. OPERATING INFORMATION

Speedometer/Tachometer Display Screen Quick Reference Chart



| | |
|-----------------------|-------------------------|
| SAFETY/ | DETAILED IDENTIFICATION |
| SPECIFICATIONS | DECALS |
| PREPARING TO OPERATE | |
| OPERATING INFORMATION | |
| TRANSPORTING | |
| SERVICE/ MAINTENANCE | |
| STORAGE | |
| TROUBLE SHOOTING | |
| LIMITED WARRANTY | |
| INDEX | |

V. OPERATING INFORMATION

STANDARD OPERATOR SEAT

- 1- **Fore-Aft Adjustment.** Pull the fore-aft lock lever to the left to unlock and adjust seat forward or rearward to desired position. Release lock lever to lock fore-aft position.
- 2- **Ride Height.** To adjust seat height, place all your body weight on the seat and locate the height adjustment dial. Rotate the dial clockwise to lower seat height and counter-clockwise to raise seat height.
- 3- **Ride Firmness.** To adjust ride firmness adjust the ride dial on the left of the seat clockwise to “soften” the ride and counter-clockwise to “stiffen” the ride.



FIG 5.41

V. OPERATING INFORMATION

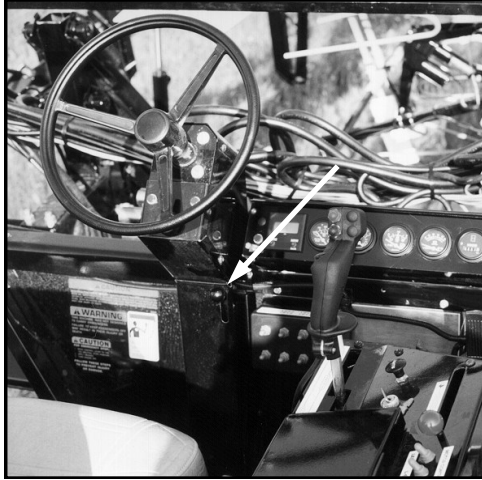

FIG 5.42



FIG 5.43



FIG 5.44

STEERING COLUMN

To adjust the HAGIE 204 SP's steering column for driver comfort or to ease cab exit and entry, locate the tilt lock lever in the center of the column (fig. 5.42). Push down on the lever to release the lock (fig. 5.43). Pull or push the column to the desired position and release the lever to re-lock the steering column.

FUEL TANK SELECTOR

To draw engine fuel from the right fuel tank, depress the fuel selector switch (fig. 5.45) to the "RIGHT" position. To switch to the left tank, depress the fuel selector switch to the "LEFT" position. You may operate from either tank until the "YELLOW" low level indicator light illuminates. Then you must either switch to the other tank or refuel.

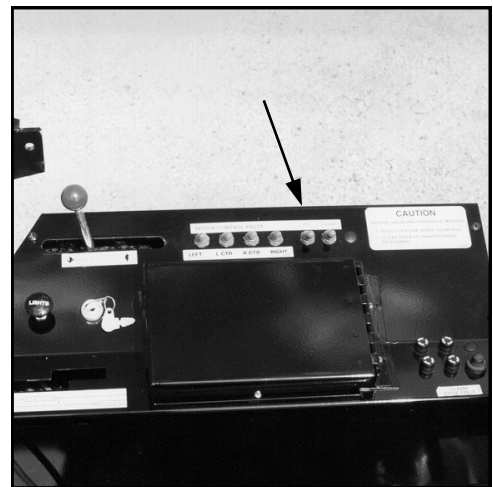

FIG 5.45

DETAILED SAFETY/
IDENTIFICATION DECALS

SPECIFICATIONS

PREPARING
INFORMATION TO OPERATE

OPERATING
INFORMATION

TRANSPORTING

SERVICE/
MAINTENANCE

STORAGE

TROUBLE
SHOOTING

LIMITED
WARRANTY

INDEX

V. OPERATING INFORMATION

LIGHTS

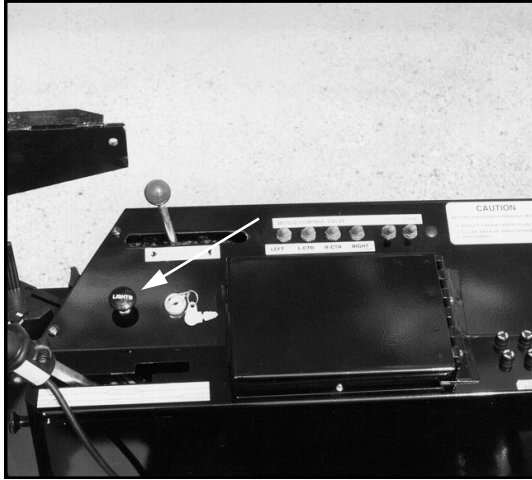

FIG 5.46

WORK LIGHTS – The front of the standard operator's station houses two halogen work lamps (fig. 5.49). The front of the optional canopy or cab houses four halogen work lamps (fig. 5.50) and the rear houses two halogen work lamps (fig. 5.48). Locate the light switch on the console panel (fig. 5.46). Pulling the switch out to the first "ON" position (fig. 5.47B) will activate all available lights. Pulling the switch out to the second "ON" position (fig. 5.47C) will deactivate the two outer front cab lights in addition to the two rear work lights (cab or canopy only).

The ignition key does not have to be on in order to operate any of the work lights, but extended use without the engine operating to charge the battery is not recommended.

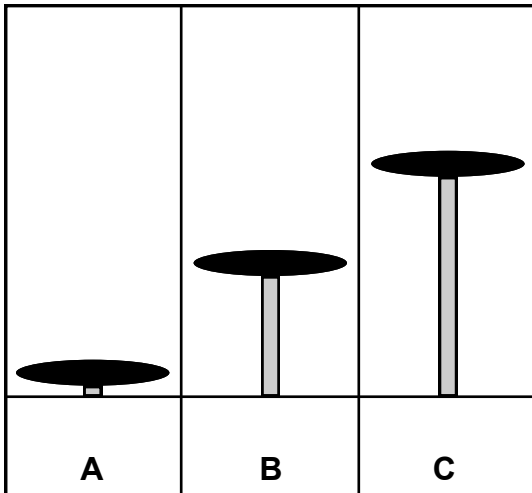

FIG 5.47



FIG 5.49

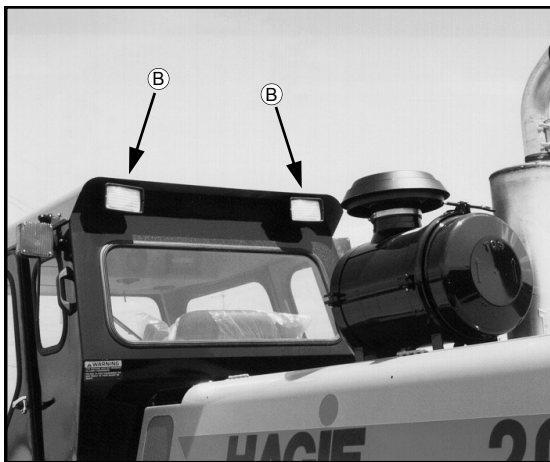

FIG 5.48

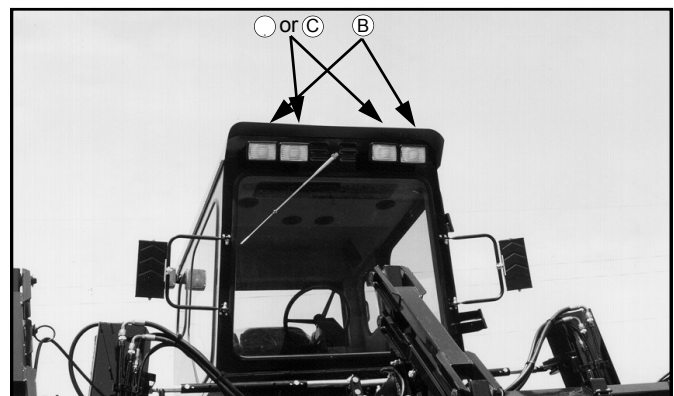

FIG 5.50

V. OPERATING INFORMATION

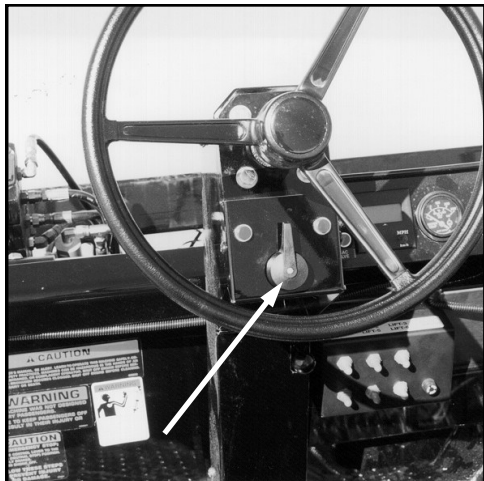

FIG 5.51

Turn Signals

To activate the front (fig. 5.53, item 1 or 2) and rear turning signals (fig. 5.53, item 3) move the turn signal lever (fig. 5.51) right during a right-hand turn and left during a left-hand turn. Steering column-mounted turn signal indicators will correspondingly flash when either side of the turn signals is activated. The turn signal lever is not a self-centering switch; you must return it to the “OFF” position by hand after completing your turn.

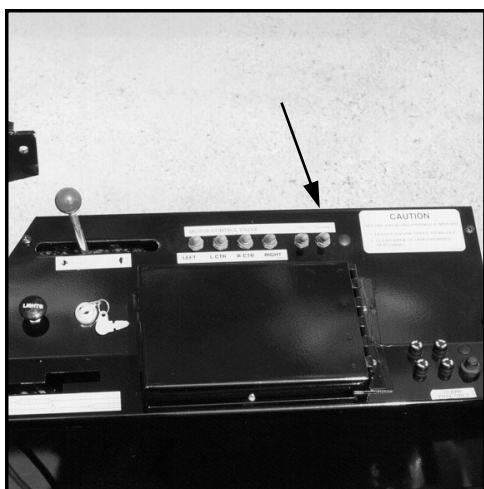

FIG 5.52

Hazard/Warning Lights

To activate the flashing hazard/warning lights (fig. 5.53, item 1 or 2) flip the “FLASHER” switch to the “ON” position (fig. 5.52). Activate the hazard/warning lights anytime traveling on a public road, day or night, unless prohibited by law.

Running Lights

Activating any of the work lights (see page 64) will also turn on the “RED” running lights on the rear of the machine (fig. 5.53, item 3).

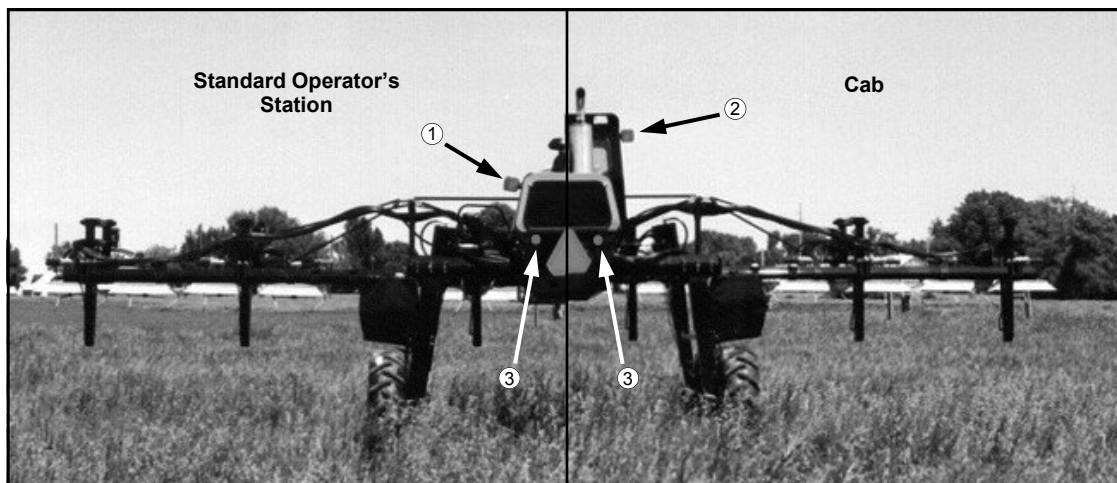

FIG 5.53

| | | | |
|-----------------------|----------------------|---------------------|---------------------------------------|
| OPERATING INFORMATION | PREPARING TO OPERATE | SPECIFICATIONS | DETAILED SAFETY/IDENTIFICATION DECALS |
| OPERATING INFORMATION | TRANSPORTING | SERVICE/MAINTENANCE | TROUBLESHOOTING |
| OPERATING INFORMATION | STORAGE | LIMITED WARRANTY | INDEX |

V. OPERATING INFORMATION

HAGIE 204 SP CAB



FIG 5.64

| | |
|-------------------------|----|
| Emergency Exit..... | 67 |
| Climate Controls | 68 |
| Air Suspended Seat..... | 69 |
| Radio..... | 70 |
| Windshield Wiper..... | 70 |
| Interior Lighting | 70 |

V. OPERATING INFORMATION



FIG 5.55

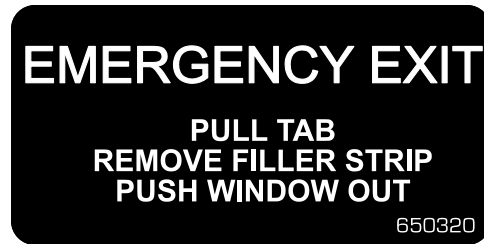

Emergency Exit

The right window in the cab is removable in the event that an emergency exit is required. To remove the rear window:

1. Grasp and pull the tag of the nylon ring next to the emergency exit decal (fig. 5.56) to remove the extrusion cord (fig. 5.57, item 1).
2. Push window outward until clear of window opening.
3. Climb out through window and away from hazardous situation.



FIG 5.56

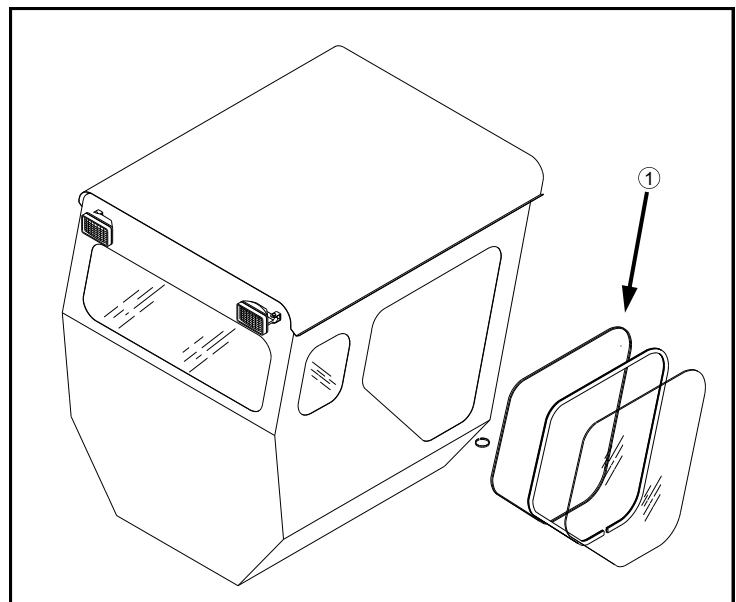

FIG 5.57

| | | | |
|----------------|------------|----------------|-------------|
| SAFETY/ | DETASSELER | IDENTIFICATION | DECALS |
| SPECIFICATIONS | | | |
| PREPARING | | | TO OPERATE |
| OPERATING | | | INFORMATION |
| TRANSPORTING | | | |
| SERVICE/ | | | MAINTENANCE |
| STORAGE | | | |
| TROUBLE | | | SHOOTING |
| LIMITED | | | WARRANTY |
| INDEX | | | |

V. OPERATING INFORMATION

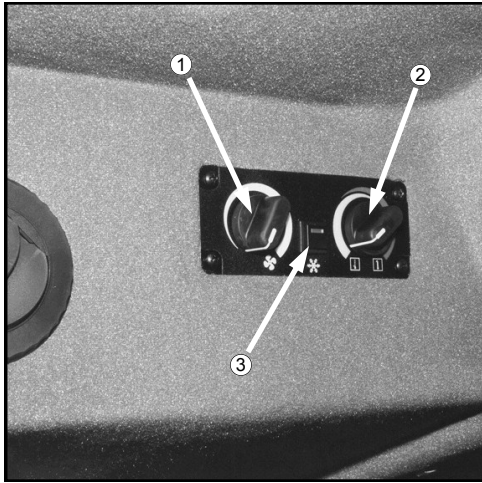

FIG 5.58

Climate Controls

ADJUSTING FAN BLOWER SPEED - Fan blower speed is controlled by the left rotary dial on the cab climate control panel (fig. 5.58, item 1). The fan blower speed is a continuously variable adjustment. To increase fan speed, rotate fan blower dial clockwise. To reduce fan speed, rotate fan blower dial counterclockwise. To shut fan blower off, rotate fan blower dial all the way counterclockwise.

ADJUSTING TEMPERATURE SETTING - Forced air temperature adjustments are controlled by the right rotary dial on the cab climate control panel (fig. 5.58, item 2). Temperature control is a continuously variable adjustment. To increase forced air temperature, rotate temperature dial clockwise. To decrease forced air temperature, rotate temperature dial counterclockwise.

OPERATING AIR CONDITIONING - To activate the air conditioner, depress the air conditioning switch (fig. 5.58, item 3). Adjust fan speed and temperature accordingly.

ADJUSTING VENTS - Air vents may be adjusted by rotating them for desired direction (fig. 5.59) or individually turned on or off with the directional fins (fig. 5.60).

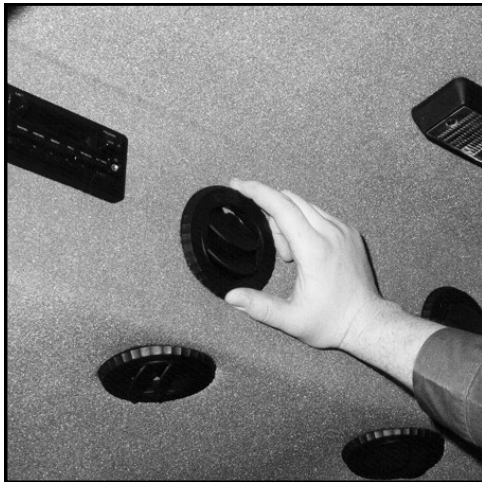
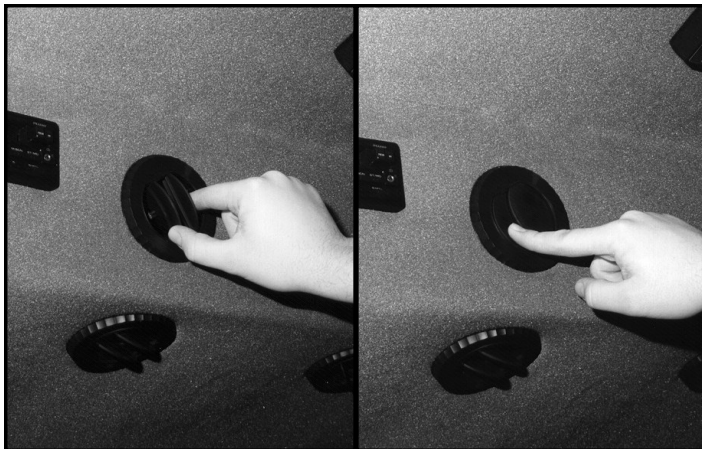

FIG 5.59

SERVICING A/C SYSTEM - See pages

81 and 84 for service information.



A

B

FIG 5.60

V. OPERATING INFORMATION

AIR SUSPENDED CAB SEAT

- 1- **Ride Firmness.** Pull knob out to release air and “soften” ride. Push knob in to pump air and “stiffen” ride. (Ignition key must be in the “ON” position in order to activate the seat pump.)
- 2- **Fore-Aft Adjustment.** Release fore-aft lock by pulling lever out. Slide forward or back to desired position. Release lever to lock.
- 3- **Height Adjustment.** Release height lock by pulling lever up. Apply body weight slowly to lower seat position or remove body weight slowly to raise seat position. When at desired height release lever to lock.
- 4- **Back Angle Adjustment.** Rotate knob counter-clockwise to tilt back rest forward and clockwise to tilt back rest back.
- 5- **Arm Rest Adjustment.** Unzip either arm rest to expose the arm rest adjustment bolt. Turn bolt in to raise arm rest tilt and out to lower arm rest tilt (fig. 5.61, item 6).



FIG 5.61

| | | | |
|-----------------------|----------------------|----------------|---------------------------------------|
| OPERATING INFORMATION | PREPARING TO OPERATE | SPECIFICATIONS | DETAILED SAFETY/IDENTIFICATION DECALS |
| SERVICE/ MAINTENANCE | TRANSPORTING | STORAGE | INDEX |
| TROUBLE SHOOTING | LIMITED WARRANTY | | |

V. OPERATING INFORMATION

Radio

Your Hagie 204 SP is equipped with an auto reverse AM/FM cassette tuner (fig. 5.62) and two speaker system. For stereo system operation and installation information refer to the radio owner's manual that accompanies this operator's manual.

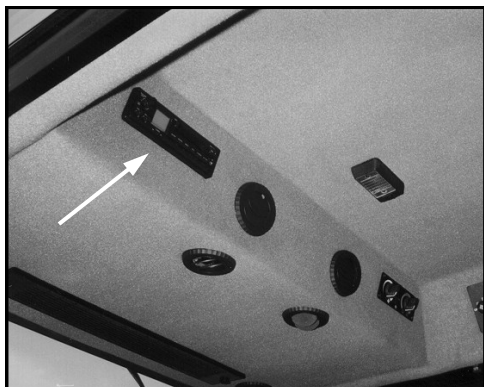

FIG 5.62

Windshield Wiper

To turn the windshield wiper on, locate the windshield switch toward the rear of the console panel (fig. 5.63). Flip the switch to the "ON" position. The wiper will continue to operate until the switch is returned to the "OFF" position.

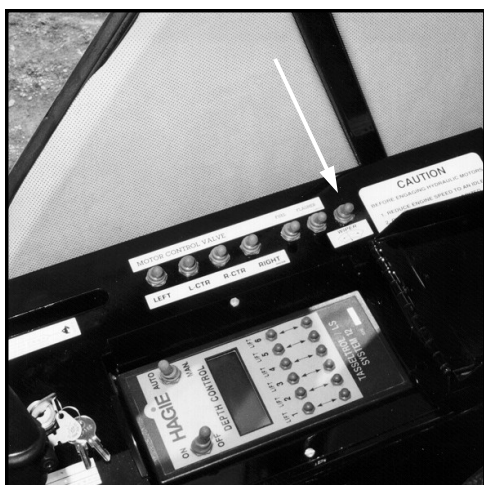

FIG 5.63

Interior Lighting

Interior lighting is provided by a ceiling mounted dome light (fig. 5.64). The ignition key must be in the "OPERATING" position for the interior light to operate.



FIG 5.64

VI. TRANSPORTING

A. DRIVING:

When driving the detasseler on a public road or highway, drive carefully and follow these steps:

1. Always have the outriggers in the folded position when driving or transporting.
2. Flashing hazard/warning lights have been placed on the detasseler to warn other drivers.
3. A SMV (Slow Moving Vehicle) emblem has been mounted on the detasseler to warn other drivers that one is moving slowly. Keep it properly displayed, unless prohibited by law.
4. Know and obey all state laws for driving farm equipment on a public road or highway.
5. Adjust the detasseler's speed to suit the conditions.
6. Slow down and use turn signals before turning.
7. Pull over to side of road before stopping.
8. Keep a proper lookout, and maintain control of the detasseler.
9. Do not drive under trees, bridges, wires, or other obstructions unless there is clearance.
10. Use extra care before entering or leaving a public road or highway.

B. TRAILERING:

NOTE:

Extra care should be taken when loading the detasseler onto any trailer. Consider whether it is best to back the detasseler on or drive the detasseler forward.

1. Loading:

NOTE:

Be sure to read and understand the trailer's owner and operator manual. Hitch the trailer to the pulling vehicle as shown in the trailer's owner and operator man-

VI. TRANSPORTING

When moving the detasseler onto a trailer, follow these steps completely:

- a. Pull the trailer to flat ground. Apply the pulling vehicle's parking brake and turn off the engine.
Use tire chocks to keep the trailer from moving.
- b. Fold in the detasseler's outriggers and lock them to the detasseler.
- c. Lower the trailer ramps and set the ramp spacing for the detasseler's tread setting.
- d. Get someone to help guide you onto the trailer. Keep everyone a safe distance from the detasseler.



- e. Allow enough room between the detasseler and the pulling vehicle for turning.
- f. Secure the detasseler to the trailer. See the trailer's owner and operator manual for instructions.
- g. Cover or remove the SMV (Slow Moving Vehicle) emblem when traveling over 25 miles per

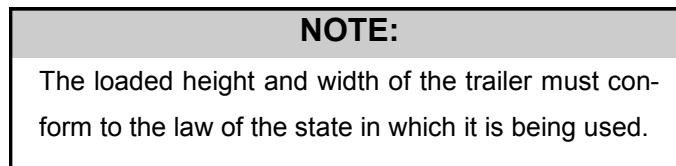

2. UNLOADING:

When moving the detasseler off of a trailer, follow these steps completely:

- a. Pull the trailer to flat ground. Apply the pulling vehicle's parking brake and turn off the engine.
Use tire chocks to keep the trailer from moving.
- b. Lower the trailer ramps and set ramp spacing for the detasseler's tread setting.
- c. Release securing restraints carefully.
- d. Get someone to help guide off the trailer. Keep everyone a safe distance from the detasseler.
- e. Uncover or replace the SMV (Slow Moving Vehicle) emblem.

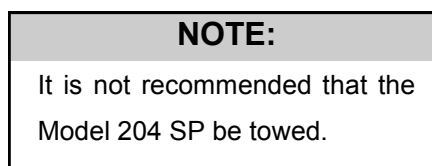

VII. SERVICE AND MAINTENANCE

| PAGE NO | Service Point | C L E A N | C H A N G E | C H E C K | G R E A S E | D R A I N |
|---------|---|-----------------------|----------------------------|-----------------------|----------------------------|-----------------------|
| 77 | ENGINE OIL | | A | DAILY | | |
| 80 | RADIATOR COOLANT LEVEL | | | DAILY | | |
| 80 | COOLANT OVERFLOW RESERVOIR LEVEL | | | DAILY | | |
| 79 | COOLANT CONCENTRATION | | AS REQ | 500 HRS* | | |
| 83 | RADIATOR GRILLE SCREENS | AS REQ | | | | |
| 92 | ENGINE DRIVE BELT | | AS REQ | DAILY | | |
| 92 | A/C COMPRESSOR BELT (CAB ONLY) | | AS REQ | 250 HRS | | |
| 81 | A/C COMPRESSOR (CAB ONLY) | | B | | | |
| 84 | A/C DRYER (CAB ONLY) | | AS REQ | | | |
| 85 | PRIMARY FUEL FILTER (WATER SEPARATOR) | | 500 HRS* | | | DAILY |
| 85 | SECONDARY FUEL FILTER | | 500 HRS* | | | |
| 85 | IN-LINE FUEL PRE-FILTER | | AS REQ | | | |
| 82 | AIR INTAKE FILTER | NOT REC | C | | | |
| 82 | FILTER MINDER® | | D | DAILY | | |
| 77 | HYDRAULIC RESERVOIR OIL LEVEL | | 500HRS** | DAILY | | |
| 83 | HYDRAULIC SUCTION FILTER | | E* | | | |
| 83 | HYDROSTATIC CHARGE PRESSURE FILTER | | E* | | | |
| 83 | HYDRAULIC RETURN FILTER | | E* | | | |
| 93 | NEUTRAL SETTING OF HYDROSTATIC PUMP | | AS REQ | DAILY | | |
| 84 | HIGH-PRESSURE IN-LINE FILTER (LIFT STACK VALVE) | AS REQ | | | | |
| 78 | TORQUE HUB® OIL LEVEL | | F | 100 HRS | | |
| 86 | TORQUE HUB® ZERK (4 PLACES - 1 EACH) | | | | 50 HRS | |
| 29 | QUAD PULLER PSI (4 PLACES EACH ROW) | | | DAILY | | |
| 87 | QUAD PULLER BEARING (4 PLACES EACH ROW) | | | | 2X DAILY | |
| 87 | MALE CORN CHOPPER BEARING (2 PLACES EACH ROW) | | | | DAILY | |
| 98 | AIR-RIDE SUSPENSION (VISUAL) | | | DAILY | | |
| 98 | AIR-RIDE SUSPENSION (TAPE MEASURE) | | | 50 HRS | | |
| 86 | LEG BEARING ZERKS (12 PLACES - 3 EACH) | | | | DAILY | |
| 95 | LEG MOUNT BOLT TORQUE | | | DAILY | | |
| 88 | BATTERY | 100 HRS | AS REQ | DAILY | | |
| 94 | LUG NUT TORQUE | | | G | | |
| 99 | TIRE PRESSURE | | | 50 HRS | | |
| 85 | FRESH AIR CAB FILTER (CAB ONLY) | AS REQ* | AS REQ | | | |
| 85 | CHARCOAL CAB FILTER (CAB ONLY) | | AS REQ | | | |
| 85 | RECIRCULATION FILTER (CAB ONLY) | | AS REQ | | | |
| 89-91 | FUSES/CIRCUIT BREAKERS | | AS REQ | | | |

*OR YEARLY, WHICHEVER COMES FIRST; OR AS REQUIRED

**OR AT THE BEGINNING OF THE SEASON, WHICHEVER COMES FIRST; OR AS REQUIRED

NOTE A: SEE ENGINE MANUFACTURER'S HAND BOOK

NOTE B: CHARGE AS REQ; USE PROPER EQUIPMENT

NOTE C: FOLLOW FILTER MINDER READINGS

NOTE D: RESET EACH TIME YOU SERVICE AIR FILTER

NOTE E: 1ST 50 HRS, THEN 250 HRS THEREAFTER

NOTE F: 1ST 50 HRS, THEN 500 HRS THEREAFTER

NOTE G: IMMEDIATELY, THEN 50 HRS THEREAFTER

SAFETY/ IDENTIFICATION DECALS
 DETASSELER IDENTIFICATION
 SPECIFICATIONS
 PREPARING INFORMATION TO OPERATE
 OPERATING INFORMATION TO OPERATE
 TRANSPORTING
 SERVICE/ MAINTENANCE
 STORAGE
 TROUBLE SHOOTING
 LIMITED WARRANTY
 INDEX

VII. SERVICE AND MAINTENANCE

SERVICE INTERVALS

Initial checks after receiving machine

IMMEDIATELY  then 

- 1) Check lug nut torque, then every 50 hours (page 94)

FIRST 50 HOURS  then  or 

- 1) Change Torque Hub[®] oil, then every 500 hours (page 78)
- 2) Change hydrostatic charge pressure filter, then every 250 hours (page 83)
- 3) Change hydraulic suction filter, then every 250 hours (page 83)
- 4) Change hydraulic return filter, then every 250 hours (page 83)

Daily 

- 1) Check engine oil (page 77)
- 2) Drain primary fuel filter (water separator) (page 85)
- 3) Check radiator coolant level (page 80)
- 4) Check radiator coolant overflow reservoir level (page 80)
- 5) Check engine drive belt (pages 92)
- 6) Check Filter Minder[®] (page 82)
- 7) Check hydraulic oil reservoir level (page 77)
- 8) Check for neutral setting of hydrostatic pump (page 93)
- 9) Grease all leg bearings (page 86)
- 10) Check leg mount bolts (page 95)
- 11) Check battery (page 88)
- 12) Check quad puller PSI (page 29)
- 13) Grease quad puller bearings (2X) (page 87)
- 14) Grease male corn chopper bearings (4X) (page 87)

VII. SERVICE AND MAINTENANCE

As Required



- 1) Change coolant concentration (page 79)
- 2) Clean radiator grille screens (page 83)
- 3) Change engine drive belt (page 92)
- 4) Change A/C compressor belt (page 92)
- 5) Change A/C dryer (page 84)
- 6) Charge A/C compressor (page 81)
- 7) Change primary fuel filter (water separator) (page 85)
- 8) Change secondary fuel filter (page 85)
- 9) Change in-line fuel pre-filter (page 85)
- 10) Change hydraulic reservoir oil (page 77)
- 11) Adjust neutral setting of hydrostatic pump (page 93)
- 12) Clean high-pressure in-line filter on lift assembly stack valve (page 84)
- 13) Change battery (page 88)
- 14) Clean fresh air intake cab filter (page 85)
- 15) Change fresh air intake cab filter (page 85)
- 16) Change charcoal cab filter (page 85)
- 17) Clean recirculation cab filter (page 85)
- 18) Replace fuses and circuit breakers (pages 89-91)
- 19) Grease Torque Hub[®] seal boot (page 86)
- 20) Adjust air-ride suspension height (page 98)

SAFETY/
DETAILED IDENTIFICATION
DECALS

SPECIFICATIONS

PREPARING
INFORMATION TO OPERATE

OPERATING
INFORMATION TO OPERATE

TRANSPORTING

SERVICE/
MAINTENANCE

STORAGE

TROUBLE
SHOOTING

LIMITED
WARRANTY

INDEX

VII. SERVICE AND MAINTENANCE

Every 50 HOURS



- 1) Check tire pressure (page 99)
- 2) Check lug nut torque (page 94)
- 3) Grease Torque Hub[®] seal boot (page 86)
- 4) Measure air bag suspension height with tape measure (page 98)

Every 100 HOURS



- 1) Check Torque Hub[®] oil level (page 78)
- 2) Clean battery (page 88)

Every 250 HOURS



- 1) Check A/C compressor belt (page 92)
- 2) Change hydrostatic charge pressure filter (page 83)
- 3) Change hydraulic suction filter (page 83)
- 4) Change hydraulic return filter (page 83)

Every 500 HOURS



or



- 1) Check coolant concentration (page 79)
- 2) Change primary fuel filter (water separator) (page 85)
- 3) Change secondary fuel filter (page 85)
- 4) Change hydraulic reservoir oil (page 77)
- 5) Change Torque Hub[®] oil (page 78)

VII. SERVICE AND MAINTENANCE

FLUIDS

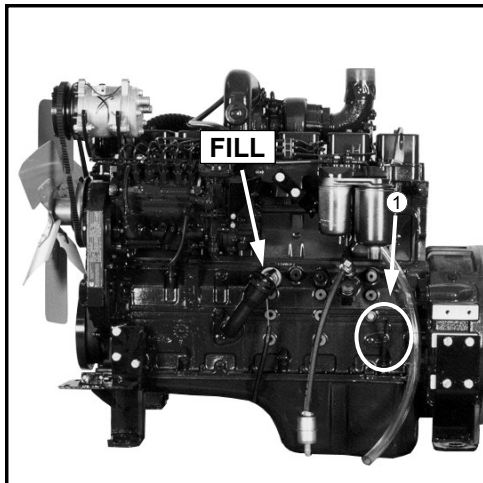

FIG 7.1

Engine oil

OIL LEVEL - The engine oil level dipstick is located on the left-hand side of the diesel engine (fig. 7.1, item 1). Never operate the engine with the oil level below the “L” (low) mark or above the “H” (high) mark. Wait at least five minutes after shutting off the engine to check the oil level; this allows time for the oil to drain to the oil pan. Check the engine oil level daily.

CAPACITY - Low to high mark capacity is 2.0 quarts. Engine oil pan capacity (including filter) is 17 quarts (SAE 15W 40). Refer to Engine Operation and Maintenance manual for maintenance schedule of the diesel engine.

NOTE:

The engine must be level when checking the oil level to make sure the measurement is correct.



FIG 7.2

Hydraulic Oil Reservoir

OIL LEVEL - Check the hydraulic oil level in the reservoir using the dipstick daily (fig. 7.2). Add just enough fluid so the level reaches the bottom tip of the dipstick. Hydraulic oil will expand when heated in a system, and measuring the reservoir by these levels allows for expansion. Always check the hydraulic oil level when it is cool and with lift cylinders in lowered position.

TYPE - Premium hydraulic fluids containing high quality rust/oxidation/and foam inhibitors are required. Hydraulic oil must conform to one of the following types: anti-wear hydraulic oil, type F automatic transmission fluid, or agricultural hydraulic transmission fluid. Replace the oil in the hydraulic reservoir at 500 hours or at the beginning of each detasseling season, whichever comes first.

DETASSELER SAFETY/
IDENTIFICATION DECALS

SPECIFICATIONS

PREPARING
INFORMATION TO OPERATE

OPERATING
INFORMATION TO OPERATE

TRANSPORTING

SERVICE/
MAINTENANCE

STORAGE

TROUBLE
SHOOTING

LIMITED
WARRANTY

INDEX

VII. SERVICE AND MAINTENANCE

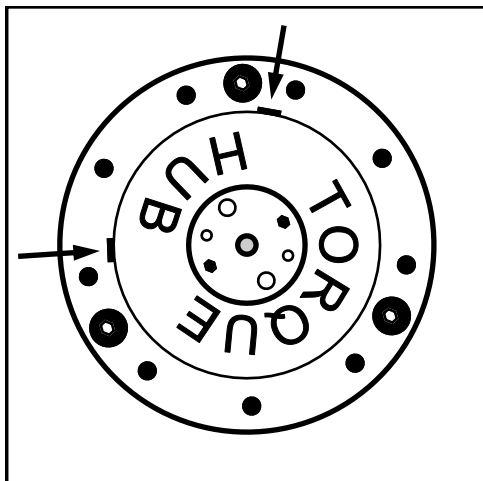

FIG 7.3



FIG 7.4



FIG 7.5

Torque Hub[®] Oil

OIL LEVEL - Each Torque Hub[®] should maintain an oil level of half full at all times. Less than that would limit lubrication, and over half full could cause overheating and damage. To check oil level, position Torque Hub[®] so one of the drain plugs is positioned at 12 O'clock (fig. 7.3). The other plug will be either at 9 O'clock or 3 O'clock. Remove the lower plug: if no oil comes out, oil level is too low. Check Torque Hub[®] oil level every 100 hours.

If EP-90 oil is needed, remove the top plug and fill until it just starts to come out the lower hole (fig. 7.4). With the oil at a satisfactory level, re-install plugs.

CHANGE - The Torque Hub[®] oil should be changed after the first 50 hours of operation. Subsequently, it should be changed every 500 hours after that, or once a year whichever comes first.

To change the Torque Hub[®] oil, position one of the plugs at 6 O'clock, and the other at either 3 O'clock or 9 O'clock. Remove the bottom plug to drain the oil. Once all of the oil is drained, re-install the bottom plug and remove the top plug. Refill Torque Hub[®] with EP-90 oil as described above.

GENERAL MAINTENANCE - If your detasseler is going to sit for an extended period of time, occasionally rotate the hubs by driving the detasseler forward or backward a few feet to adequately coat all internal hub parts (fig. 7.5). This will prevent rusting if moisture inadvertently entered the hub during an oil change. Failure to rotate hub and disperse oil may cause rusting and internal damage.

VII. SERVICE AND MAINTENANCE

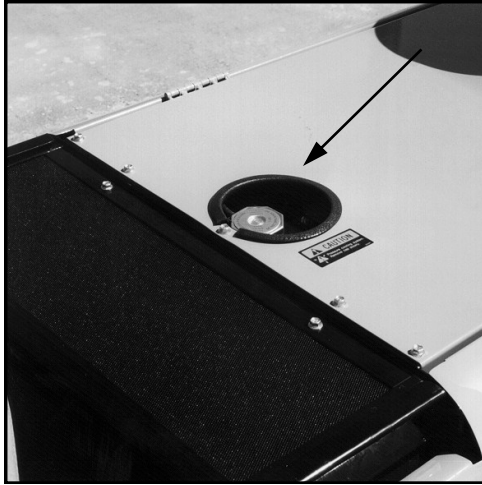

FIG 7.6



FIG 7.7

| Ethylene Glycol | | |
|-----------------|-------|-------|
| 40% | -23°C | -10°F |
| 50% | -23°C | -34°F |
| 60% | -23°C | -65°F |

FIG 7.8

Cooling System

COOLANT TYPE - Your cooling system should always be sufficiently charged with an adequate mixture of antifreeze and water, regardless of the climate, in order to maintain a broad operating temperature range. Your cooling system has been factory-charged with an ethylene glycol-based antifreeze.

NOTE:

Ethylene glycol-based antifreeze and propylene glycol-based antifreeze should never be

CHECKING CONCENTRATION - The radiator cap is located immediately behind the rear of the operator's station (fig. 7.6). Never remove a cap from a hot engine. Always allow the engine to cool before servicing cooling system.

A 50/50 antifreeze/water mixture is a conservative mixture which allows good protection against both overheating and freezing. If a stronger antifreeze mixture is required, be sure not to exceed the engine manufacturer's guidelines for antifreeze mixing. The table in figure 7.8 gives a few examples of ethylene glycol antifreeze/water mixture protection values. Consult the engine manufacturer's handbook for further information.

Concentration should be checked every 500 hours or at the beginning of each winter, whichever comes first. It should be checked using a refractometer; "floating ball"-type density testers or hydrometers are not accurate enough for use with heavy duty diesel cooling systems.

SAFETY/ IDENTIFICATION DECALS
 SPECIFICATIONS
 PREPARING TO OPERATE
 OPERATING INFORMATION
 TRANSPORTING
SERVICE/ MAINTENANCE
 STORAGE
 TROUBLE SHOOTING
 LIMITED WARRANTY
 INDEX

VII. SERVICE AND MAINTENANCE

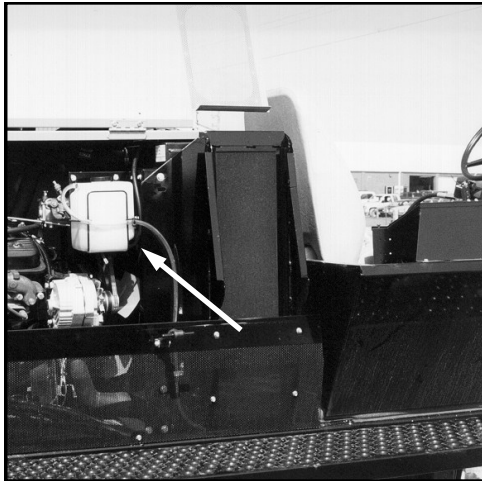

FIG 7.9

COOLANT RESERVOIR - The coolant reservoir is located under the right-hand hood behind the radiator (fig 7.9). Check its level everyday while the engine is cold. Maintain the coolant reservoir level within the normal cold range marks.

CHANGING COOLANT - Your coolant should periodically be changed to eliminate the buildup of harmful chemicals. Drain and replace the coolant every other detasseling season or every 1,000 hours of operation, whichever comes first. Refill only with ethylene glycol coolant. Antifreeze should be mixed only with soft water because hard water contains minerals which breakdown the anti-corrosion properties of antifreeze.

Fuel

No. 2 diesel fuel is recommended for the best economy and performance under most operating conditions. In operating conditions under 32° F, use a blend of No. 1 and No. 2 diesel fuel. The addition of No. 1 diesel fuel may cause loss of power and/or fuel economy.

STORING - See section 8 on detasseler storage.

REFILLING - Always turn off the engine and allow it to cool before refueling. Never smoke while fueling. Keep a fire extinguisher within reach while refueling.

Each tank holds 40 gallons - do not fill them completely: fuel can expand and run over. Wipe up all spilled fuel and clean with detergent and water before starting the engine.

PRIMING - If the fuel system should happen to run dry and lose its prime, there is a priming bulb located on the left side of the engine for use in filling the engine fuel filters (fig. 7.11).

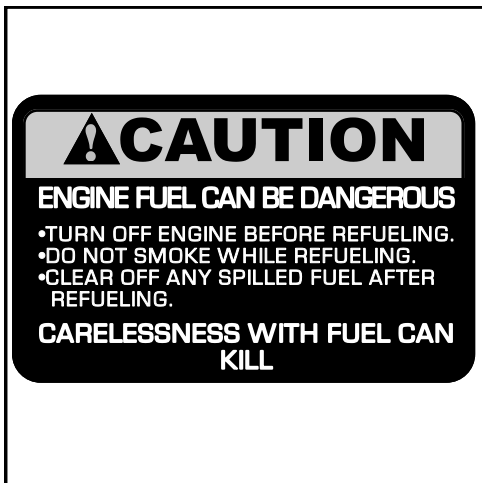

FIG 7.10

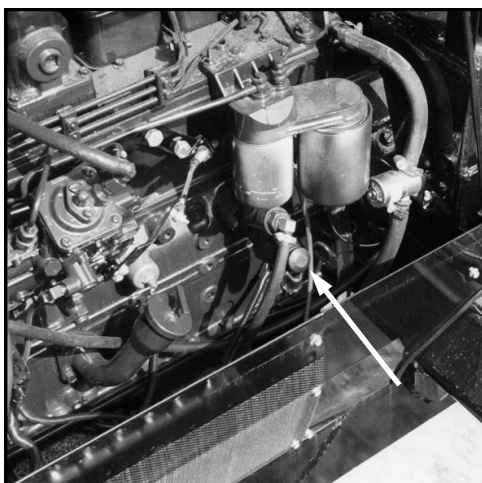

FIG 7.11

VII. SERVICE AND MAINTENANCE

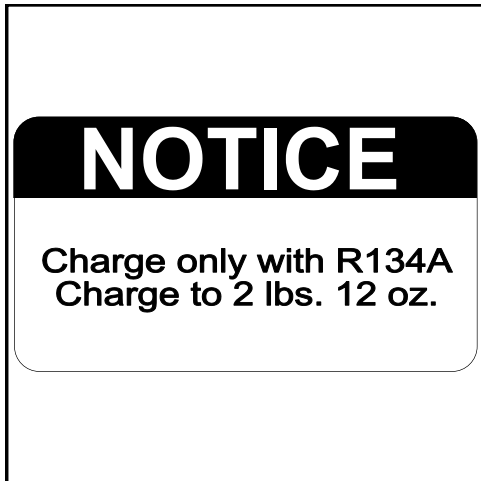

FIG 7.12

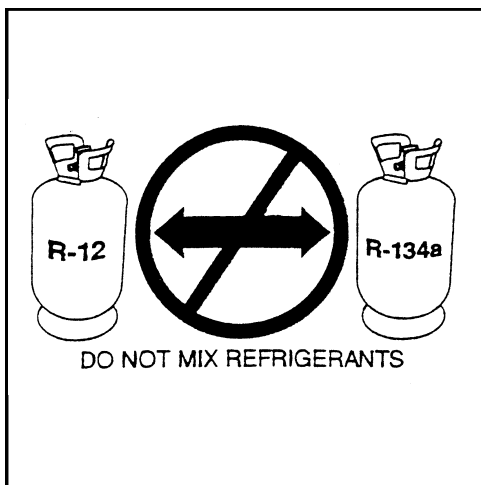

FIG 7.13

Air Conditioning

TYPE - The cab on your detasseler is equipped with a R-134a air conditioning system.

RECHARGING - Recharge it only with R-134a refrigerant. If your air conditioning system is mistakenly charged with R-12 refrigerant, serious problems, such as compressor seizure, may result. Therefore, confirm refrigerant before recharging system.

If you do not have the proper recharging equipment, it is recommended that you allow an independent service agent service your air conditioning system.

| FLUID CAPACITIES AND TYPES | |
|---|--|
| Engine oil pan (including filter) | 17 quarts SAE 15W-40 |
| Engine oil dipstick, L-H mark | 2 quarts |
| Hydraulic oil reservoir | 25 gallons anti-wear hydraulic oil |
| Torque Hub® oil level | approx. 16 oz. EP-90 |
| Engine cooling system | 7 gallons ethylene glycol |
| Fuel tanks (2) | 40 gallons ea. No. 1 or 2 diesel |

SAFETY / IDENTIFICATION DECALS
 DETASSLER IDENTIFICATION DECALS
 SPECIFICATIONS
 PREPARING TO OPERATE
 OPERATING INFORMATION
 TRANSPORTING
SERVICE / MAINTENANCE
 STORAGE
 TROUBLE SHOOTING
 LIMITED WARRANTY
 INDEX

VII. SERVICE AND MAINTENANCE

FILTERS

Engine Air Intake



FIG 7.14

REMOVAL - The engine air intake filter element should only be removed if it is going to be replaced. After loosening the air cleaner clamp and removing the end cap, carefully remove the filter so as to not knock any dust off the filter and into the air intake passage (fig. 7.15).

REPLACEMENT - Your detasseler is equipped with a Filter Minder[®] to notify you of filter element efficiency. Follow its guidelines for servicing. (See below.) At appropriate service time, install the new element carefully to ensure proper sealing.

CLEANING - It is not recommended to clean the air filter element. However, a clean damp cloth should be used to wipe dust and foreign material from the air cleaner housing before a new element is installed.



FIG 7.15

Filter Minder[®]

The Filter Minder[®] is an air restriction monitoring system that progressively and constantly indicates how much air filter capacity remains. Check its reading daily (fig. 7.16).

Service the air cleaner when the Filter Minder[®] reads 20" (80% of average dirt holding capacity). Reset the Filter Minder[®] to zero each time you replace the air filter element.

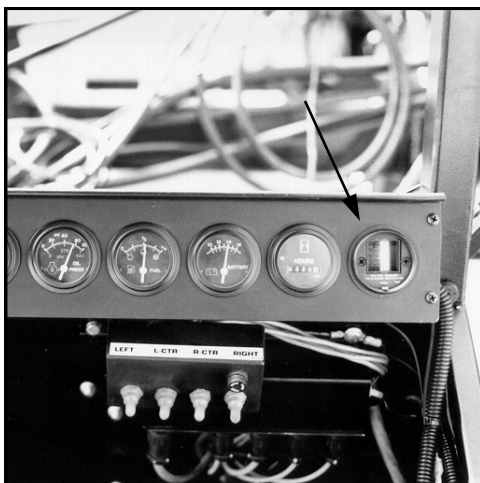

FIG 7.16

NOTE:

Service the air cleaner before the yellow indicator reaches the red line of the Filter Mind-

VII. SERVICE AND MAINTENANCE



FIG 7.17



FIG 7.18

Grille Screens

In order to maintain maximum air flow through the engine cooling system's radiator, oil cooler, and air conditioning condenser, the cooling air intake grille screens must be inspected often and periodically removed for cleaning.

REMOVAL - The side grille screens are easily removed by sliding them up out of their housings (fig. 7.17). The top screen is held in place by two bolts (fig. 7.17) and may also be removed for cleaning.

CLEANING - Compressed air will dislodge most large trash or loose dirt after the screens have been removed. Blow out the screens away from the machine. Water from a pressurized hose may also be used, or if necessary the screens may be soaked in soapy water and scrubbed with a brush.

NOTE:

When cleaning cooling fins of the radiator, oil cooler, or A/C condenser with compressed air or water, be careful not to damage cooling fins which may impair cooling capabilities.

Hydraulic/Hydrostatic Filters

SUCTION FILTER – Remove and install a new 10 Micron rated suction filter (fig. 7.18, item 3) at the end of the first 50 hours of use; subsequently, replace the filter every 250 hours, or once a year, whichever comes first.

CHARGE PRESSURE FILTER – Remove and install a new 4 Micron rated charge pressure filter (fig. 7.18, item 2) at the end of the first 50 hours of use; subsequently, replace the filter every 250 hours, or once a year, whichever comes first.

RETURN FILTER – Remove and install a new 10 Micron rated return filter (fig. 7.18, item 1) at the end of the first 50 hours of use; subsequently, replace the filter every 250 hours, or once a year, whichever comes first.

VII. SERVICE AND MAINTENANCE

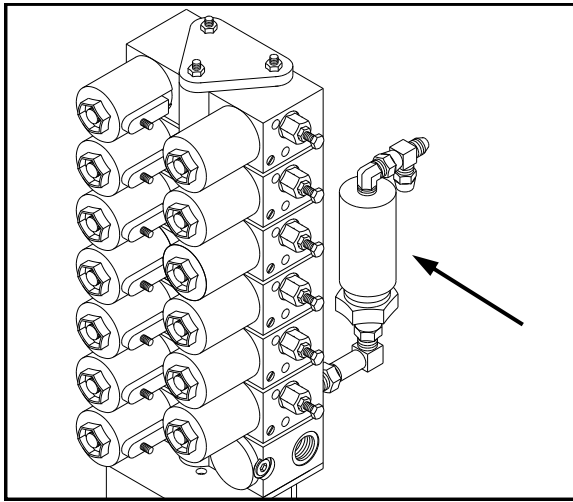

FIG 7.19

High Pressure In-line Filters

STACK VALVES - The valves on the lift control stack valve are protected by a 90 Micron in-line sintered bronze filter (fig. 7.19). When the filter element is removed for cleaning, caution should be taken so the gasket is in the proper place when re-installing (fig. 7.20). Also, re-install filter paying attention to direction of flow so the end marked "OUT" is oriented correctly.

A/C System Dryer (if equipped)

The A/C system receiver/dryer (fig. 7.21) should be replaced if the A/C loop is ever opened such as replacing a compressor or condenser line, etc.

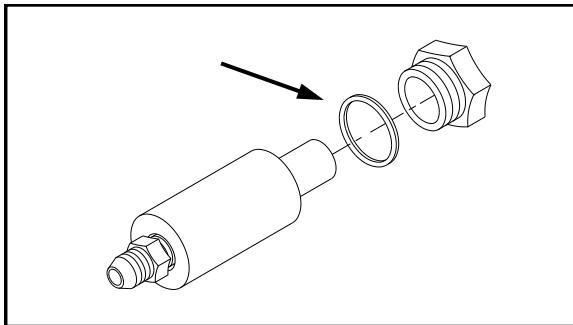

FIG 7.20

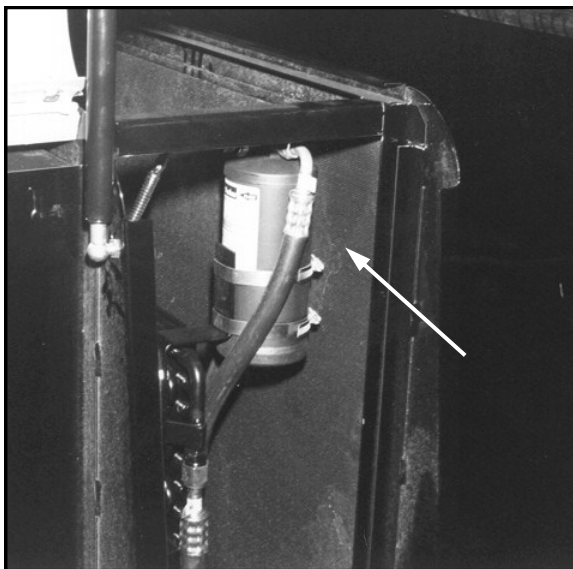

FIG 7.21

VII. SERVICE AND MAINTENANCE

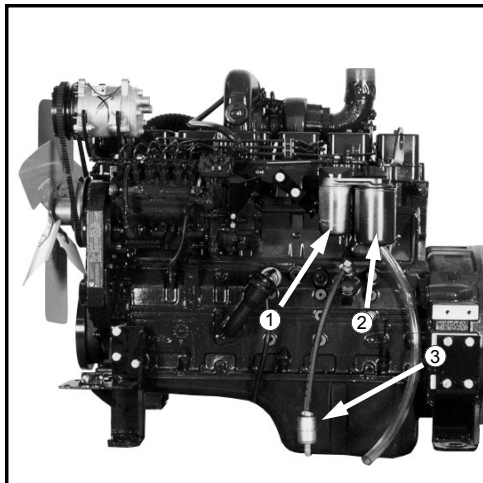

FIG 7.22

Fuel Filters

PRIMARY (WATER SEPARATOR) - (fig. 7.22, item 2) Drain water and sediment from the separator daily. Replace every 500 hours or once a year, whichever comes first.

SECONDARY - (fig. 7.22, item 1) Replace every 500 hours or once a year, whichever comes first.

IN-LINE STRAINER - (fig. 7.22, item 3) Note direction of fuel flow arrow when replacing.

Fresh Air Cab Filters

PAPER FILTER - (fig. 7.23, item 1) The paper filter should be cleaned once a year, or more often if necessary. Remove the paper element and gently tap it against a flat surface. Direct low

pressure compressed air through the filter to remove larger particles. Replace the paper filter if necessary.

CHARCOAL FILTER - (fig. 7.23, item 2) Remove and replace at the first sign of chemical odor entering the cab.

RECIRCULATING FILTER - (fig. 7.23, item 3) The recirculating filter may be cleaned with soap and water. Replace, if it becomes worn.

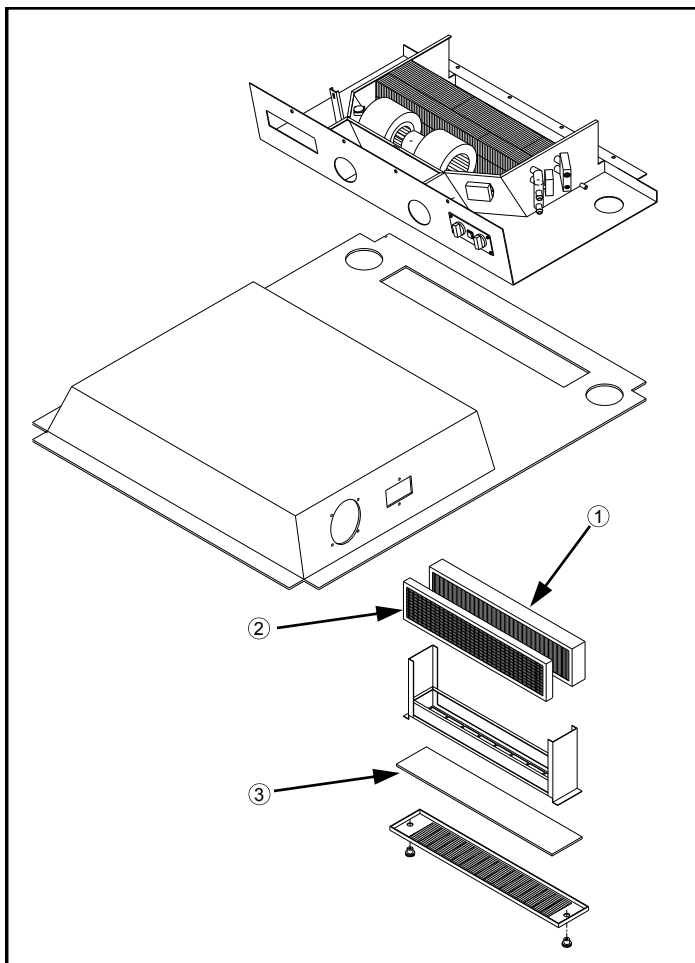

FIG 7.23



CAB FILTER LOCATION
FIG 7.24

DETASLER SAFETY/
 IDENTIFICATION DECALS
 SPECIFICATIONS
 PREPARING
 INFORMATION TO OPERATE
 OPERATING
 INFORMATION TO OPERATE
 TRANSPORTING
 SERVICE/
 MAINTENANCE
 STORAGE
 TROUBLE
 SHOOTING
 LIMITED
 WARRANTY
 INDEX

VII. SERVICE AND MAINTENANCE

LUBRICATION

Leg Bearings

Hagie 204 SP leg assemblies are constructed with upper and lower nylon bearings for suspension telescoping between the inner and outer leg weldments. These bearings must be lubricated to avoid bearing failure and ensure optimal ride quality. There are grease zerks located on the sides of the leg assemblies, one for the upper bearing (fig. 7.25, item 1) and two for the lower bearing (fig. 7.25, item 2). Greasing both bearings on both front legs daily is very important.

During operation of the detasseler, the grease may possibly be wiped off by passing crop leaves, so the bearings should be greased at least twice a day. Suggested times are in the morning and at noon. If the crop is mature enough, or plant population is high enough, more frequent leg bearing grease application may be required. This will ensure proper lubrication allowing optimal performance.

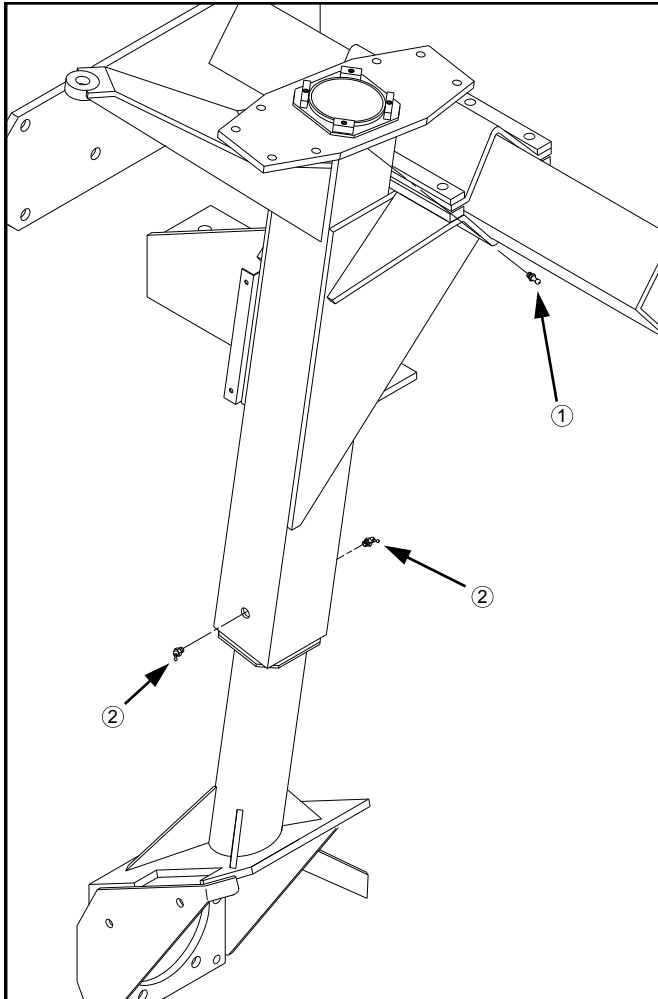

FIG 8.25

Torque Hub[®] Seal Boot

Each leg has a seal boot located between the wheel motor and Torque Hub[®]. Seal boot grease zerks (fig. 7.26) should be greased once every 50 hours or as needed. An over-greased seal boot will leak some grease out around the seal and when heated may cause the appearance of a failed wheel motor leaking hydraulic fluid. Wipe off any excess grease after servicing.



FIG 7.26

VII. SERVICE AND MAINTENANCE

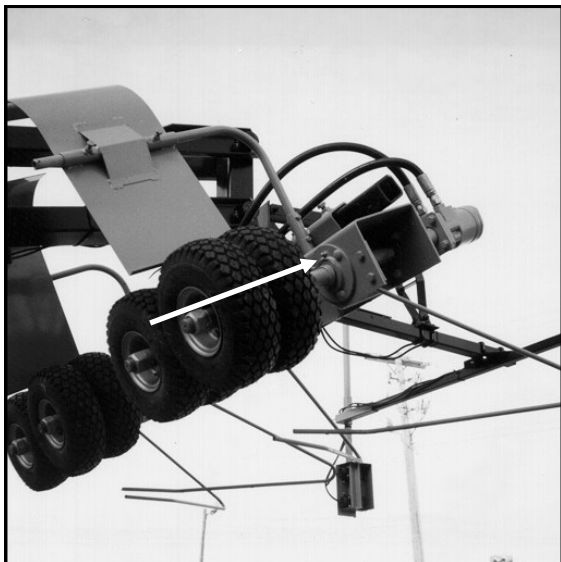

FIG 7.27

Quad Pullers

Each quad puller head has four bearings equipped with grease zerks (fig. 7.27). To ensure the longest life and best performance, grease each bearing twice a day: suggested times are morning and noon.

Four Blade Male Row Cutters

Grease both upper (fig. 7.28, item 1) and lower (fig. 7.28, item 2) shaft bearings 4 times a day. Suggested times are morning, mid-morning, noon, and mid-afternoon.

Male Row Choppers

Each male row chopper has two bearings equipped with grease zerks (fig. 7.29). Grease each bearing once a day.

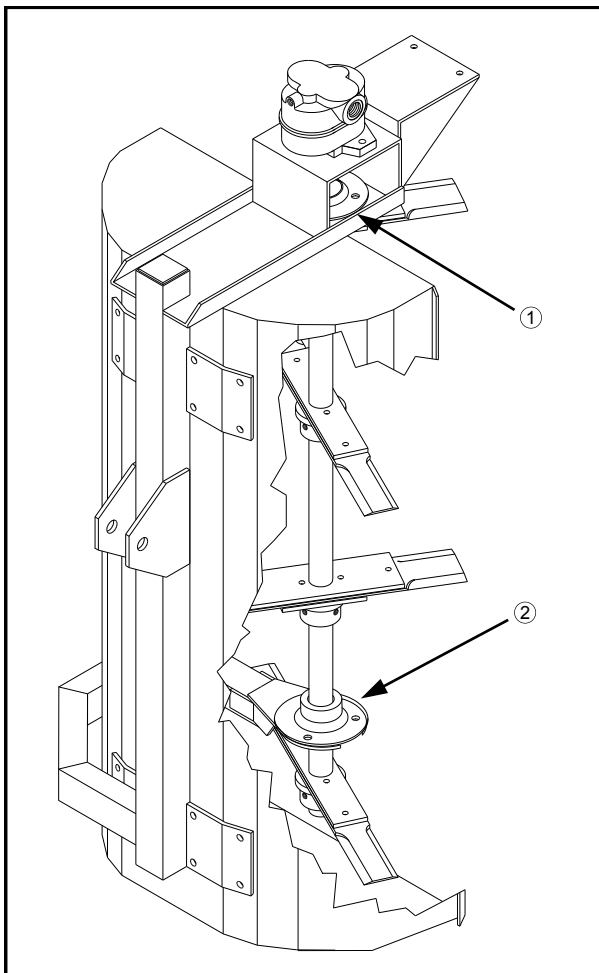

FIG 7.28

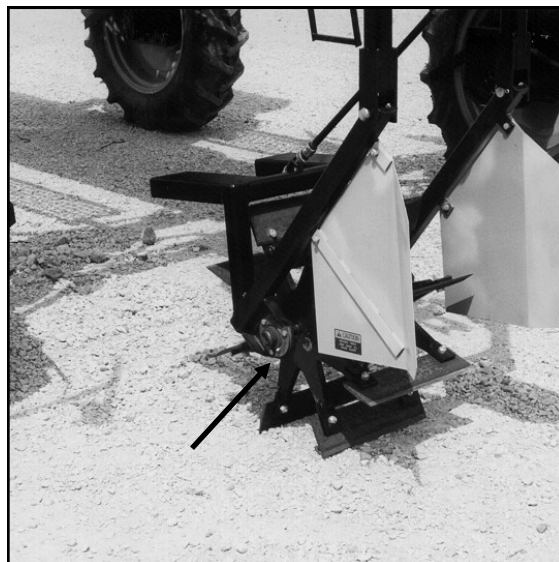

FIG 7.29

| | |
|----------------|-------------|
| DETAILER | SAFETY/ |
| IDENTIFICATION | DECALS |
| SPECIFICATIONS | |
| PREPARING | TO OPERATE |
| OPERATING | INFORMATION |
| TRANSPORTING | |
| SERVICE/ | MAINTENANCE |
| STORAGE | |
| TROUBLE | SHOOTING |
| LIMITED | WARRANTY |
| INDEX | |

VII. SERVICE AND MAINTENANCE

ELECTRICAL

Battery

SAFETY



FIG 7.30

VOLTAGE..... 12 V (only)

COLD CRANKING AMPS
(30 sec. at 0° F)..... 950 CCA

RESERVE
CAPACITY..... 185 min.
at 25 amps

FIG 7.31

CAUTION

Batteries contain sulfuric acid. Avoid contact with skin, eyes, or clothing. Do not inhale fumes or ingest liquid. Batteries contain gases which can explode. Keep sparks and flame away while servicing.

NOTE:

When servicing electrical system always disconnect the battery. Remove ground cable first and connect it

CLEANING - Disconnect battery cables from battery. Remove all corrosion with a wire brush or battery post brush. Wash the cable connections and battery posts with a weak solution of baking soda or ammonia. Apply petroleum jelly or grease to prevent future corrosion. Reconnect the cables to the battery making sure they are tight. Clean every 100 hours.



CAUTION

Electrical system is 12 volt negative ground. When using booster with jumper cables, precautions must be taken to prevent personal injury or damage to electrical parts.

1. Attach one end of jumper cable to positive terminal of booster battery and other end to positive terminal of vehicle battery connected to starter motor.
2. Attach one end of second cable to negative terminal of booster battery and other end to vehicle frame away from battery. Do not attach to cab or cab support.
3. To remove cables, reverse above sequence exactly to avoid sparks. See operator's manual for additional information.

STORAGE - See page 101 for proper battery storage.

REPLACEMENT - When replacing the battery, install a battery with ratings equivalent to or higher than the specs listed in figure 7.31.

NOTE:

To ensure the best electrical contact, battery terminal connections should be as clean and as tight as possi-

VII. SERVICE AND MAINTENANCE



FIG 7.32

| | |
|--|--------|
| Motor control block | 10 AMP |
| Tasselrol [®] box, seat motor (cab only) | 10 AMP |
| Gauges, traction valve, dome light (cab only), AM/FM radio (cab only) | 10 AMP |
| Flasher/turn signal, running lights, windshield Wiper (cab only), fuel pumps (gas only), Fuel selector valve (diesel only) | 10 AMP |

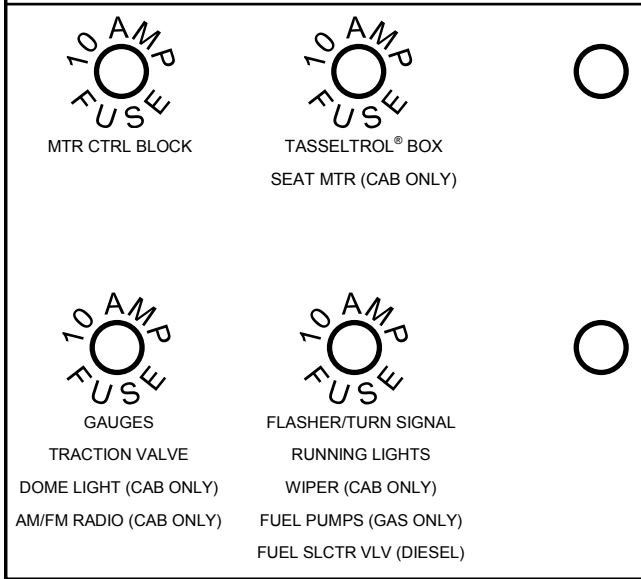

FIG 7.33

Fuses

Fuses protect individual lighter duty electrical circuits. They are located toward the rear console panel to the right of the operator's seat (fig. 7.32).

If a fuse blows, remove it by rotating the fuse cap counterclockwise as you push down. Then pull the fuse straight out (fig. 7.34). Replace each blown fuse with the same amperage fuse only.

Correct fuse location and amperage is shown in figure 7.33. If the fuse continues to blow, determine the cause and correct it.

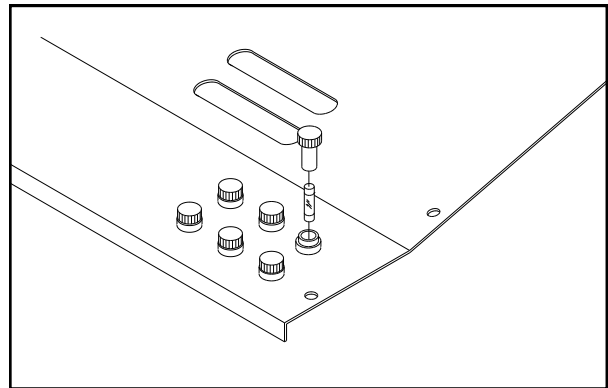

FIG 7.34

SAFETY/ IDENTIFICATION DECALS

SPECIFICATIONS

PREPARING INFORMATION TO OPERATE

OPERATING INFORMATION TO OPERATE

TRANSPORTING

SERVICE/ MAINTENANCE

STORAGE

TROUBLE SHOOTING

LIMITED WARRANTY

INDEX

VII. SERVICE AND MAINTENANCE



FIG 7.35

Depth Command Fuse

The fuse for the DEPTH COMMAND is located in the switch box (fig. 7.35). If the DEPTH COMMAND fuse blows, remove it by rotating the fuse cap counter-clockwise as you push in. Then pull the fuse straight out. Replace the blown fuse with the same amperage fuse only (fig. 7.36).

Operating more than two actuators at one time may cause the fuse to blow (see page 58). A blown fuse may indicate that the LS/DEPTH COMMAND pivot bolts (fig. 7.37) are torqued too tight. If the fuse continues to blow, determine

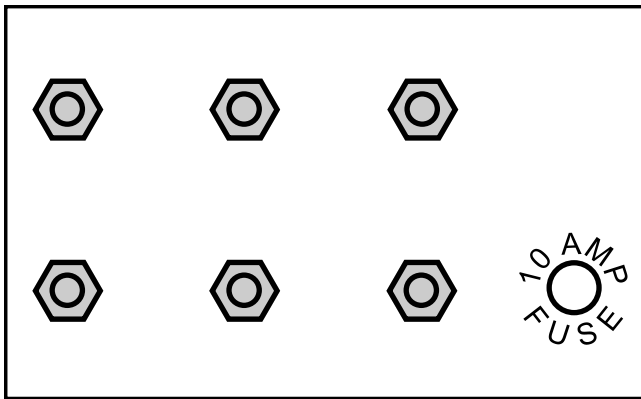

FIG 7.36

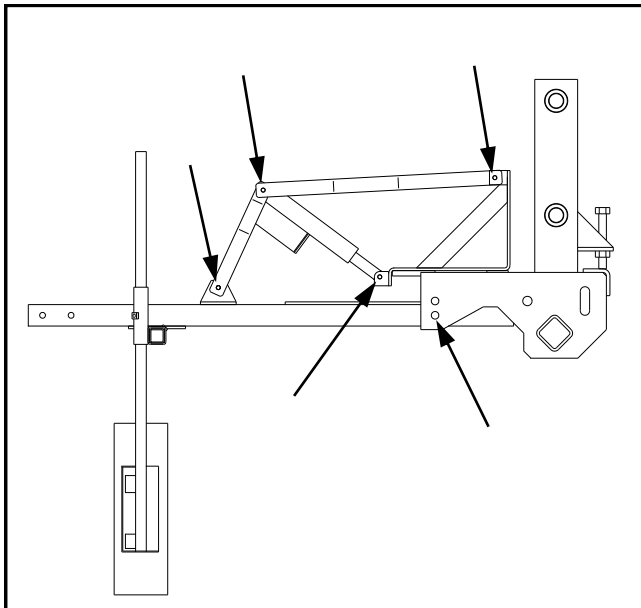

FIG 7.37

VII. SERVICE AND MAINTENANCE

Circuit Breakers

Circuit breakers handle the functions of the heavier duty electrical circuits on the detasseler. They trip when overloaded and automatically reset themselves after they cool down. They will continue to trip and reset as long as the overload or short exists. If the circuit breaker does not reset, replace it with the same amperage breaker only. Correct circuit breaker location and amperage is shown in figure 7.40.

To access the circuit breakers remove the

hydrostatic handle (fig 7.38, item 1), VFC lever knobs (fig. 7.38, item 2), and panel screws (fig. 7.38, item 3). The circuit breakers are located toward the rear of the console.

The wire harness on the diesel engine are protected by circuit breakers mounted on the engine (fig. 7.39).

If the circuit breaker does not reset and continues to trip, determine the cause and correct it.

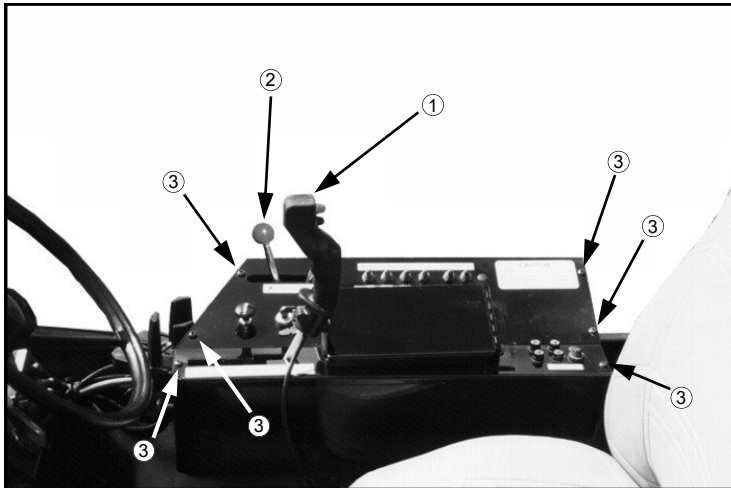

FIG 7.38

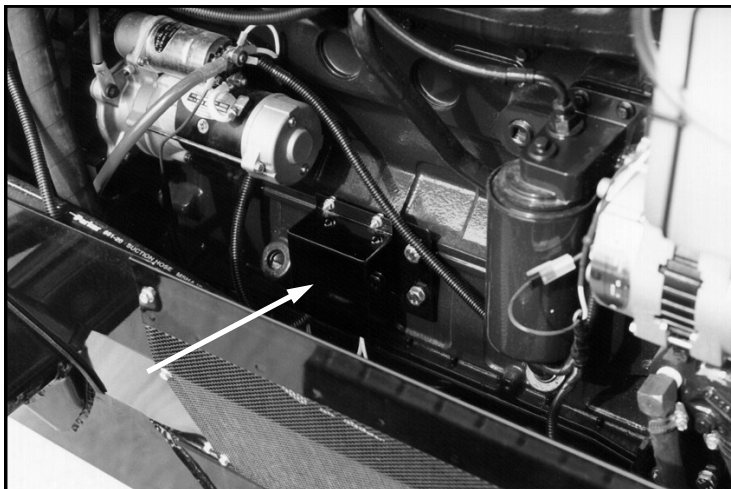

FIG 7.39

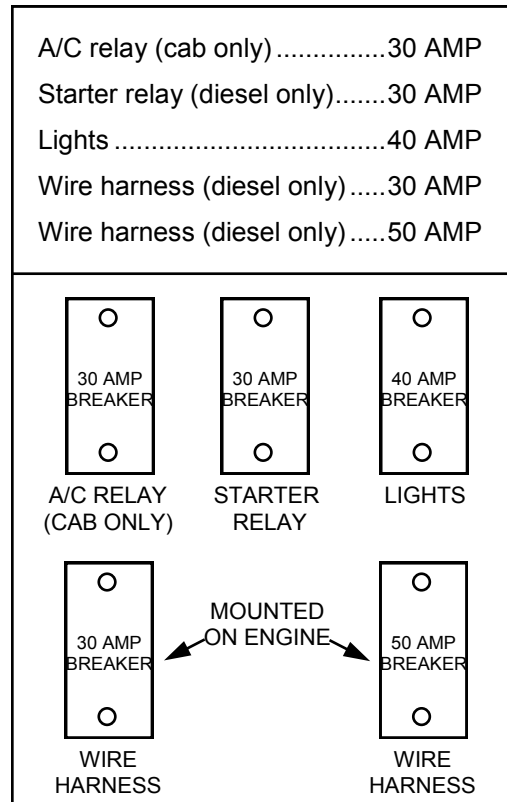

FIG 7.40

SAFETY/ IDENTIFICATION
 DETASSELER IDENTIFICATION
 SPECIFICATIONS
 PREPARING TO OPERATE
 OPERATING INFORMATION
 TRANSPORTING
 SERVICE/ MAINTENANCE
 STORAGE
 TROUBLE SHOOTING
 LIMITED WARRANTY
 INDEX

VII. SERVICE AND MAINTENANCE

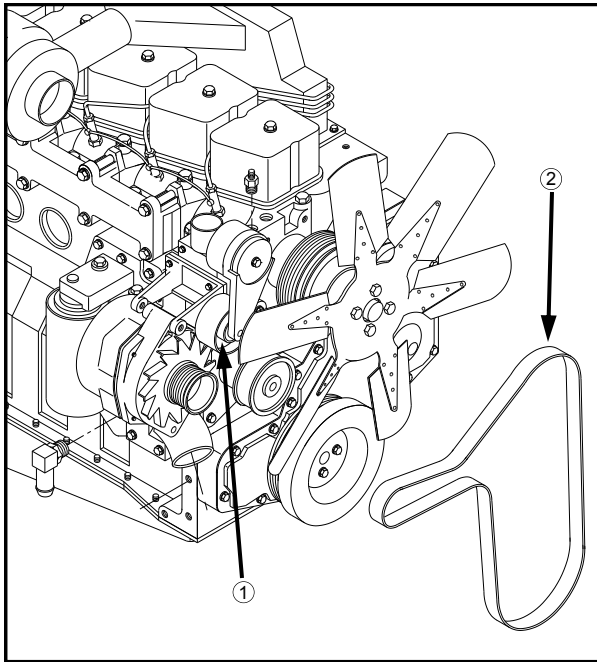

FIG 7.41

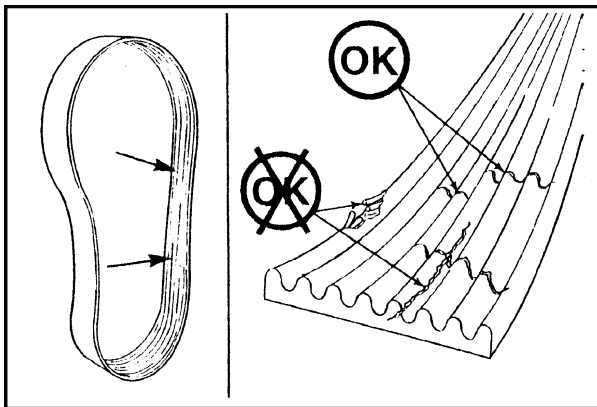

FIG 7.42

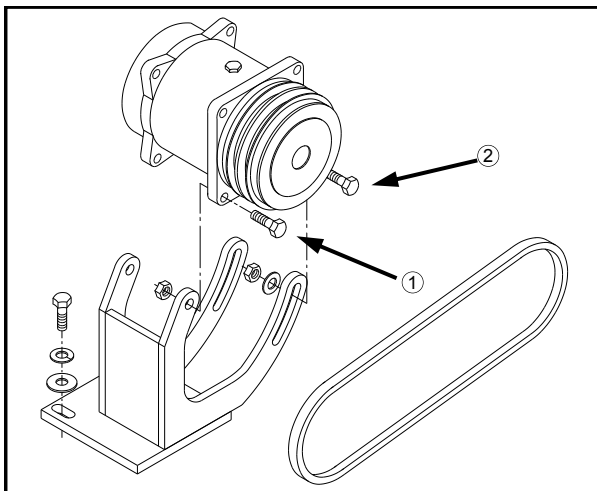

FIG 7.43

BELTS

Engine Drive Belt

REMOVAL - Insert a 3/8 inch square ratchet drive into the belt tensioner (fig. 7.41, item 1) and lift upward to remove the belt (fig. 7.41, item 2).

INSPECTION - Visually inspect the belt daily (fig. 7.42). Check the belt for intersecting cracks (fig. 7.42). Transverse (across the belt width) cracks are acceptable. Longitudinal (direction of belt length) cracks that intersect with transverse cracks are not acceptable. Replace the belt if it is frayed or has pieces of material missing.

A/C Compressor Belt (if equipped)

To tighten air conditioner compressor belt, loosen the two pivot bolts (fig. 7.43, item 1) and the two slide bolts (fig. 7.43, item 2). Using a suitable prying tool, adjust tension on belt to desired tautness. While maintaining tension, re-tighten all four bolts. Inspect belt every 250 hours.

VII. SERVICE AND MAINTENANCE

DRIVE TRAIN

Hydrostatic Pump

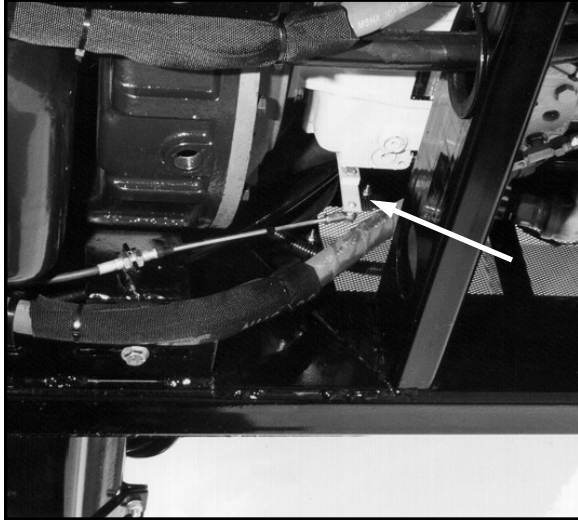

FIG 7.44

NEUTRAL SETTING - When the hydrostatic lever is in the neutral position, the machine should not be moving in either direction. If it does, the neutral setting of the lever (fig. 7.44) on the hydrostatic pump needs to be adjusted. See accompanying pump manual.

CHECK CHARGE PRESSURE - See page 40.

REPAIR/REPLACEMENT - See pump handbook accompanying this operator's manual. Hydrostatic pumps are available as a core exchange item from Hagie Manufacturing Customer Support Department.

Auxiliary Gear Pumps

REPAIR/REPLACEMENT - See pump handbook accompanying this operator's manual. Gear pumps are available from the Hagie Manufacturing Customer Support Department.

Wheel Motors

REPAIR/REPLACEMENT - See wheel motor handbook accompanying this operator's manual. Wheel motors are available as a core exchange item from Hagie Manufacturing Customer Support Department.

Torque Hubs[®]

GREASE - Grease according to page 86.

OIL - Maintain oil level according to page 78.

REPAIR/REPLACEMENT - See Torque Hub[®] manual accompanying this operator's manual.

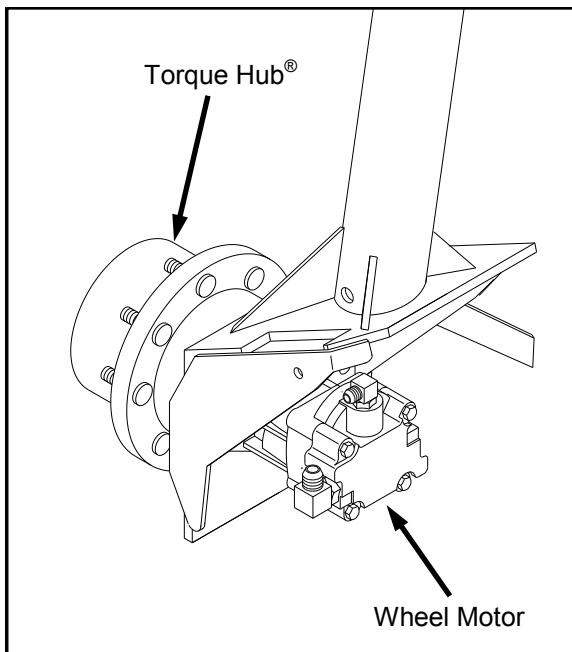

FIG 7.45

VII. SERVICE AND MAINTENANCE

BOLT TORQUE



FIG 7.46

Wheel Bolts

To install wheel and tire assembly on the Torque Hub[®], lubricate Torque Hub[®] studs with anti-seize grease. Align the wheel bolt holes with the Torque Hub[®] studs and mount the wheel on the hub.

NOTE:

To achieve even torquing consistency, the tire should be completely off the ground.

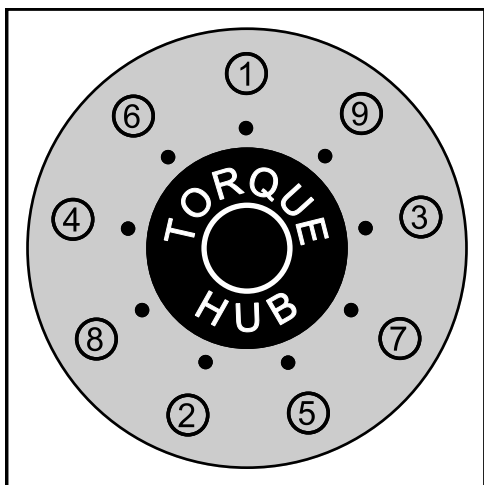

FIG 7.47

Start all of the lug nuts on and tighten them until they are just snug. Following the torque sequence in figure 7.47, first turn each lug nut to a torque value of 120 dry foot-pounds. Use slow, even pressure on the torque-wrench. Quick or jerky movements cause inaccurate values. Repeat the same sequence to 150 dry foot-pounds and again finally to 180 dry foot-pounds.

CAUTION

Check lug nut torque immediately after receiving machine and every 50 hours thereafter.

If the wheel turns during lug nut torquing, lower the machine to the ground just enough for the tire to touch and prevent rotation or more preferably, place a suitable wedge between the tire and the ground.

Lower the machine and resume operation. Recheck torque after 30 minutes of operation.



FIG 7.48

Keep wheel bolts tight.
See owner's manual for
torque specifications.

VII. SERVICE AND MAINTENANCE

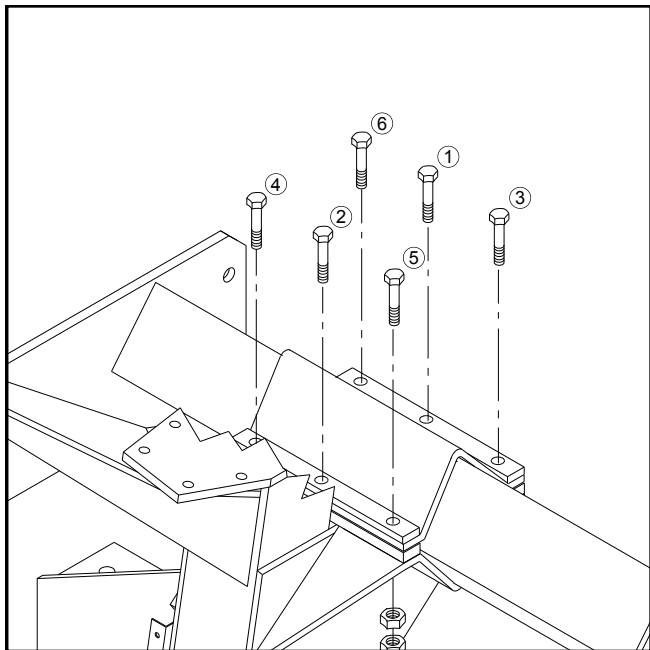

FIG 7.49

Leg Mounting Bolts

NOTE:

See page 23 for additional information regarding leg mounting

Follow these procedures for torquing the leg mounting bolts:



CAUTION

Never remove more than three leg mounting bolts from any single leg

Start the nuts on the mounting bolts and tighten them until they are just snug. Following the torque sequence in figure 7.49, turn each lug nut to a torque value of 100 dry foot-pounds. Use slow, even pressure on the torque wrench. Quick or jerky movements cause inaccurate values.

Lower the detasseler to the ground and repeat the same sequence to 130 dry foot-pounds and again finally to 160 dry foot-pounds.

Resume operation and recheck torque values after 30 minutes of operation.

SAFETY/
DETASSELER
IDENTIFICATION
DECALS

SPECIFICATIONS

PREPARING
INFORMATION TO OPERATE

OPERATING
INFORMATION TO OPERATE

TRANSPORTING

SERVICE/
MAINTENANCE

STORAGE

TROUBLE
SHOOTING

LIMITED
WARRANTY

INDEX

VII. SERVICE AND MAINTENANCE

TOE-IN

To correctly gauge toe-in, use a tape measure placed at one-half tire height on the front center seam of the front tire compared to the same measurement of the rear of the front tire (subtract the front measurement from the rear measurement - it must be a positive number). Correct toe-in should fall somewhere between one half and three quarters of an inch.

Toe-in is pre-set at the factory and should not have to be adjusted unless the steering cylinders

are removed.

Difficulty steering one way versus the other may also indicate incorrect toe-in and may require adjustment. For further assistance regarding toe-in measurement and adjustment, contact the Hagie Customer Support Department.

NOTE:

See page 97 for instructions on adjusting toe-in.

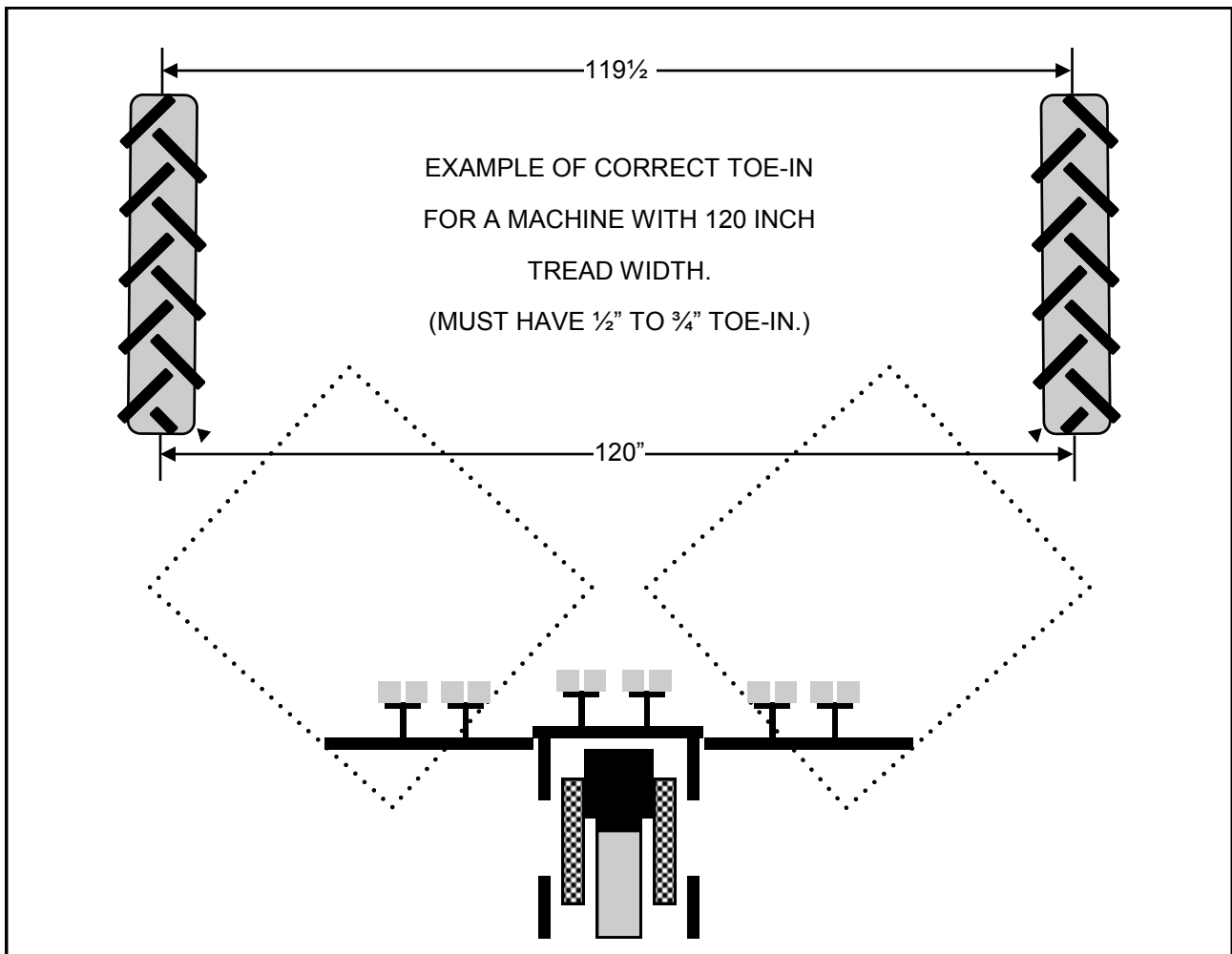

FIG 7.50

VII. SERVICE AND MAINTENANCE

TOE-IN ADJUSTMENT

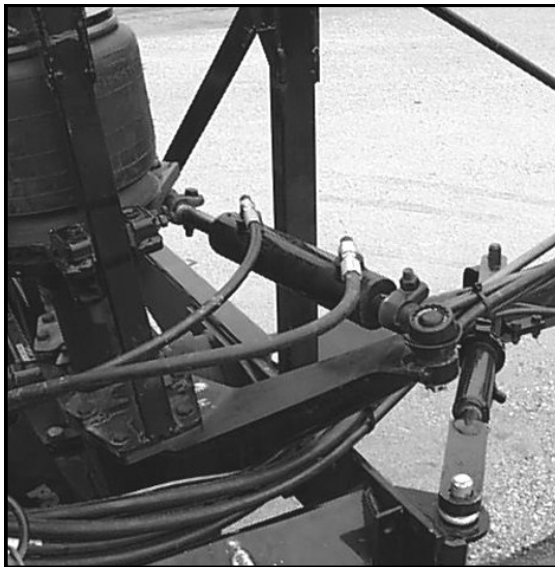

FIG 7.51

To adjust the toe-in of the front tires follow these instructions for both front steering cylinders carefully:

1. Remove cotter pin (fig. 7.52, item 5), castle nut (fig. 7.52, item 3), and lock washer (fig. 7.52, item 4).
2. Loosen lock collar bolt and nut (fig. 7.52, item 2).
3. Lightly tap swivel assembly (fig. 7.52, item 1) out of steering arm.
4. Move left and right tires evenly until difference in dimension "A" and "B" (fig. 7.53) are within specified

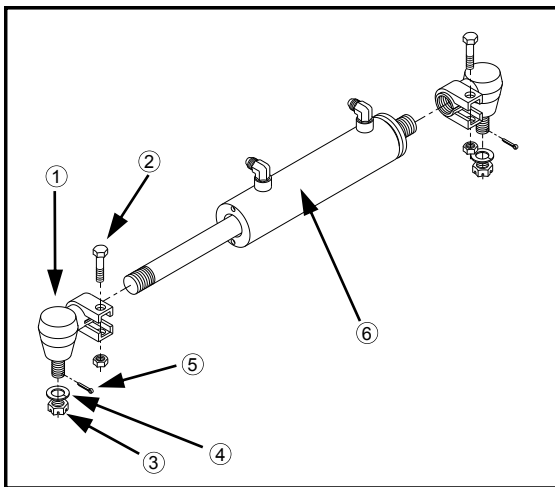

FIG 7.52

NOTE:
Dimension "A" should be $\frac{1}{2}$ " to $\frac{3}{4}$ " less than dimension "B." For more information regarding toe-in, see page

range.

5. Screw swivel assembly in or out on steering cylinder (fig 7.52, item 6) until the treaded part lines up with steering arm.
6. Insert swivel assembly into steering arm.
7. Install lock washer and castle nut and tighten.
8. Install cotter pin.

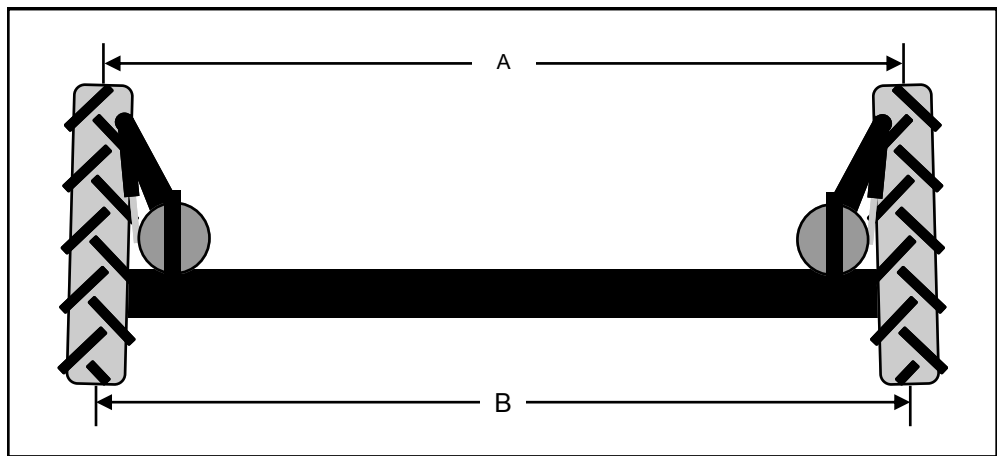

FIG 7.53

DETASLER SAFETY/
IDENTIFICATION DECALS
SPECIFICATIONS
PREPARING
OPERATING INFORMATION TO OPERATE
INFORMATION TO OPERATE
TRANSPORTING
SERVICE/
MAINTENANCE
STORAGE
TROUBLE SHOOTING
LIMITED WARRANTY
INDEX

VII. SERVICE AND MAINTENANCE

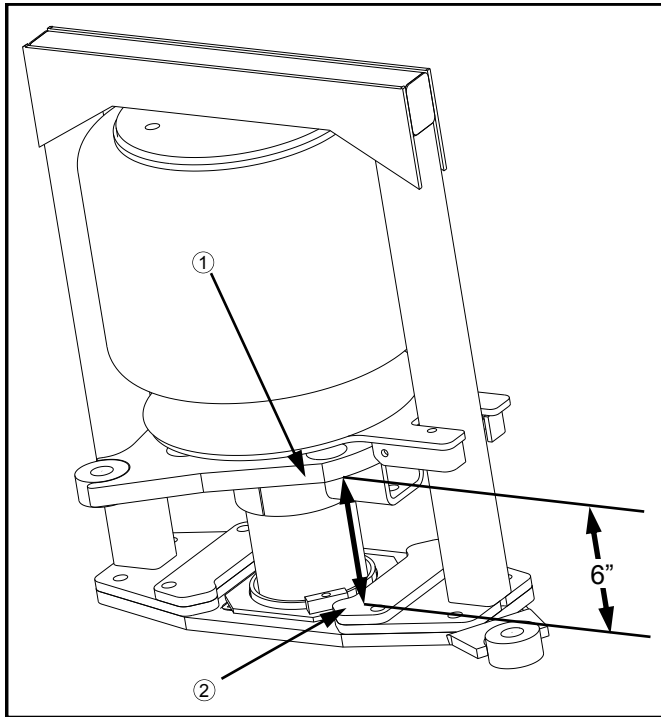

FIG 7.54

SUSPENSION

Air-Ride Adjustment

Park the machine on level ground with outriggers completely unfolded in field operating position. Adjust the air pressure in each air bag until the distance between the bottom of the steering plate (fig. 7.54, item 1) and the top of the bumper pad strike plate (fig. 7.54, item 2) is 6 inches. With a clear path on level ground, drive the machine forward 100 yards, cycling the steering back and forth, shifting machine weight from side to side. Stop on level ground and remeasure and adjust as necessary. Repeat procedure until desired measurement is achieved.

Visually check each air bag height each day and adjust if necessary. Check each bag height with a tape measure every 50 hours and adjust if necessary.



WARNING

Air spring can explode, causing serious injury or death to you or others. Do not exceed 100 psi.

VII. SERVICE AND MAINTENANCE

TIRES



FIG 7.55

Air Pressure

Check tire pressure once a week or every 50 hours of operation (fig. 7.55). Never inflate a tire more than the recommended maximum air pressure. Use an air line with a locking air chuck and stand behind tire tread while filling (fig. 7.56).

NOTE:

Tire pressure will depend on load quantity due to various options installed. Refer to page 21 for tire specifications.



FIG 7.56

WARNING

When inflating tire use extension hose with in-line air gauge and clip-on air chuck, which allow operator to stand clear of tire side wall explosion trajectory.

Wheel Bolts

See page 94 for recommended wheel bolt torque specifications and torquing pattern.

Mounting

If you do not have proper mounting equipment, let your local qualified tire sales/service dealer mount the tire for you. Tire should be mounted on rim according to figure 7.57 for best traction and tread cleaning action.

Toe In

See pages 96 and 97 for information regarding toe-in measurement and adjustment.

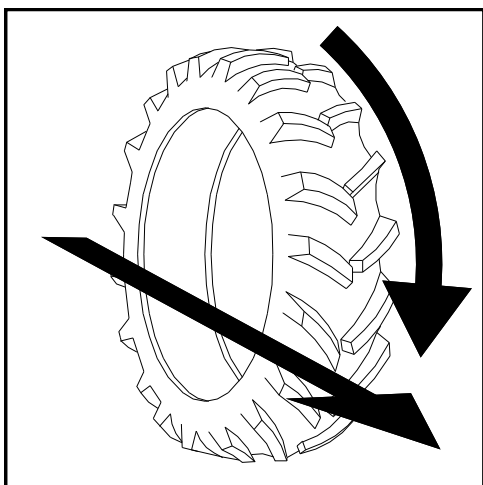

FIG 7.57

DETAILED SAFETY/
IDENTIFICATION DECALS

SPECIFICATIONS

PREPARING
INFORMATION TO OPERATE

OPERATING
INFORMATION TO OPERATE

TRANSPORTING

SERVICE/
MAINTENANCE

STORAGE

TROUBLE
SHOOTING

LIMITED
WARRANTY

INDEX

VII. SERVICE AND MAINTENANCE

DAILY INSPECTION

| Inspection Point | Action (if necessary) |
|--|-----------------------------|
| Check | |
| Engine oil level..... | Add oil |
| Radiator coolant level..... | Add antifreeze solution |
| Coolant overflow reservoir level..... | Add antifreeze solution |
| Engine drive belt | Replace belt |
| Filter Minder®..... | Replace air filter element |
| Hydraulic reservoir oil level | Add hydraulic oil |
| Neutral setting of hydrostatic pump | Adjust setting |
| Visual inspection of leg mounting bolts..... | Tighten |
| Visual inspection of air bag height | Adjust height |
| Battery..... | Clean and/or tighten |
| Radiator grille screens | Remove and clean |
| Look for loose or missing items such as shields..... | Tighten or replace |
| Look for any fluid leaks pooled on machine or ground | Determine cause and correct |
| Quad puller tire pressure (if equipped) (4 places each row)..... | Add air |
| Cutter blade retaining bolt..... | Tighten |
| Grease | |
| Upper and lower leg bearings | See page 86 |
| Quad puller bearings (if equipped) (4 places each row)..... | See page 87 |
| Male corn chopper (if equipped) (2 places each row)..... | See page 87 |
| Drain | |
| Fuel/water separator | See page 85 |

VIII. STORAGE

A. Preparing the detasseler for storage.

1. Perform daily level checks, lubrication, and bolt and linkage inspections as required in this manual in section seven on maintenance.
2. Every other season, drain the coolant from the engine and radiator. Probe the drain holes during draining to ensure they are not clogged by sludge, scale, or other deposits. Fill the cooling system to the top with a 50/50 water/antifreeze mixture. Run engine to operating temperature and re-check level.

NOTE:

If antifreeze is added, make sure the engine is then run to operating temperature to assure proper mixing of solution.

3. Add a fuel stabilizer to the fuel and fill fuel tank.
4. Run the engine until it is at operating temperature, then drain the engine oil. Refill with fresh oil of recommended weight and install a new lubricating oil filter element.
5. With the engine at normal operating temperature, cycle all hydraulic functions including the steering.
6. Release tension on all belts. For more detailed information, consult the manufacturer's handbook that accompanies this manual.
7. Use plastic bags and water-resistant adhesive tape to seal the air intake opening, all exhaust manifold openings, engine oil filler cap, hydraulic oil tank breather cap, and fuel tank caps.
8. Disconnect and remove battery or batteries. Completely clean and charge the battery. Coat the terminals with petroleum jelly and store battery in cool, dry place.
9. Thoroughly clean the detasseler. Touch up any painted surfaces that are scratched or chipped. For touch-up paint recommendations contact the Hagie Manufacturing Customer Support Department.
10. Replace worn or missing decals. See pages 7-13 for proper location of warning decals and their corresponding part number. Warning decals and all other Hagie decals are available through the Hagie Manufacturing Customer Support

NOTE:

For replacement decals contact:
Hagie Manufacturing Company
Box 273, Clarion, IA 50525
Ph. 1-800-247-4885

SAFETY/
DETASSELER IDENTIFICATION
DECALS

SPECIFICATIONS

PREPARING
INFORMATION TO OPERATE

OPERATING
INFORMATION TO OPERATE

TRANSPORTING

SERVICE/
MAINTENANCE

STORAGE

TROUBLE
SHOOTING

LIMITED
WARRANTY

INDEX

VIII. STORAGE

11. Use a multi-purpose grease to coat exposed hydraulic cylinder rods to prevent rusting which could result in cylinder damage.
12. If the sprayer must be stored outside, cover it with a waterproof cover.

B. Removing the detasseler from storage.

1. Inspect the condition, and test the air pressure, of all tires. Please see page 99 for information regarding proper tire maintenance.
2. Carefully unseal all openings that were sealed in the storage process.
3. Clean and reinstall the battery. Be sure to attach the battery cables to the proper terminals.
4. Tighten all belts. Inspect and replace any worn belts. For information on belts, see page 92.
5. Check engine oil, hydraulic oil, and engine coolant levels; add, if necessary. A mixture of 50/50 antifreeze and water will cool adequately in summer as well as protect in winter.

NOTE:

Protective compounds such as grease can harden under exposure to weather condi-

6. Completely clean the detasseler.
7. Review section seven on maintenance (pages 73-100), and perform all needed services as instructed.
8. For starting instructions, see pages 38-39 in section five on operating information.

NOTE:

See Warranty on page 119 concerning **improper storage**.

IX. TROUBLE SHOOTING

A. ENGINE



CAUTION

Start engine from operator's seat only. When running engine in a building, be sure there is adequate ventila-

| PROBLEM | POSSIBLE CAUSE | SUGGESTED REMEDY |
|--------------------|---|--|
| Engine won't crank | <p>Dead battery</p> <p>Poor battery connections</p> <p>Neutral safety switch (located in the Sauer/Sundstrand pump)</p> <p>Starter or starter relay</p> | <p>Recharge or replace battery</p> <p>Clean and tighten</p> <p>Adjust and/or replace if needed</p> <p>Test; rebuild or replace</p> |
| Engine won't start | <p>Out of fuel</p> <p>Clogged fuel filters</p> <p>Cold weather</p> <p>Low starter speed</p> | <p>Fill fuel tank</p> <p>Replace fuel filters</p> <p>Refer to engine manual for cold weather starting information</p> <p>Check starter and battery</p> |

SAFETY/ DETASLER IDENTIFICATION DECALS
 SPECIFICATIONS
 PREPARING INFORMATION TO OPERATE
 OPERATING INFORMATION TO OPERATE
 TRANSPORTING
 SERVICE/ MAINTENANCE
 STORAGE
TROUBLE SHOOTING
 LIMITED WARRANTY
 INDEX

IX. TROUBLE SHOOTING

| PROBLEM | POSSIBLE CAUSE | SUGGESTED REMEDY |
|---|---|--|
| Engine overheats | <p>Engine overloaded</p> <p>Dirty radiator core or dirty grill screens</p> <p>Faulty radiator cap</p> <p>Loose or faulty fan belt</p> <p>Faulty thermostat</p> <p>Low coolant level</p> | <p>Reduce load</p> <p>Remove all foreign material and clean all items</p> <p>Replace cap</p> <p>Tighten or replace fan belt</p> <p>Replace thermostat</p> <p>Refill to proper level with recommended coolant</p> |
| Engine misfires: runs uneven, low power | <p>Water in fuel</p> <p>Dirty air cleaner element</p> <p>Poor grade of fuel</p> <p>Fuel tank vent clogged</p> <p>Clogged fuel filter</p> | <p>Drain, flush, replace filter, fill system</p> <p>Replace element</p> <p>Drain system; change to good grade</p> <p>Open fuel tank vent in cap</p> <p>Replace fuel filter</p> |
| Engine knocks | <p>Low oil level in crankcase</p> <p>Cold engine</p> | <p>Add oil to full mark</p> <p>Allow proper warm-up period; refer to engine owner's handbook</p> |

NOTE:

For additional engine information, consult engine manufacturer's manu-

IX. TROUBLE SHOOTING

C. HYDROSTATIC SYSTEM



CAUTION

DO NOT GO NEAR LEAKS. High pressure oil easily punctures skin causing injury, gangrene, or death. If injured, seek emergency medical help. Immediate surgery is required to remove oil. Do not use finger or skin to check for leaks. Lower load or relieve hydraulic pressure before loosening fit-

| PROBLEM | POSSIBLE CAUSE | SUGGESTED REMEDY |
|---|-----------------------------------|---|
| Machine won't move in either direction | Engine speed too low | Set engine at operating RPM before trying to move machine |
| | Oil level in reservoir low | Fill reservoir to proper level w/ approved oil; see section on Service and Maintenance |
| | Control linkage | Repair or replace |
| | Clogged filter | Replace filter |
| | Hydrostatic pump not turning | Check drive coupling |
| | Faulty hydrostatic pump | Replace pump |
| | Air leak in suction line | Inspect and tighten all fittings on suction line |
| | Low charge pressure | See section under charge pressure |
| Machine will move in only one direction | Faulty high pressure relief valve | Switch relief valves from side to side; If problem reverses, replace faulty valve (Call Hagie Customer Support Department and refer to part manual) |

SAFETY / IDENTIFICATION DECALS
 SPECIFICATIONS
 PREPARING TO OPERATE
 OPERATING INFORMATION
 TRANSPORTING
 SERVICE / MAINTENANCE
 STORAGE
TROUBLE SHOOTING
 LIMITED WARRANTY
 INDEX

IX. TROUBLE SHOOTING

| PROBLEM | POSSIBLE CAUSE | SUGGESTED REMEDY |
|--------------------------------------|---|--|
| Hydrostatic system responding slowly | <p>Engine speed too low</p> <p>Oil level in reservoir low</p> <p>Cold oil</p> <p>Plugged filter</p> <p>Partially restricted suction line</p> <p>Internal damage</p> | <p>Set engine at operating RPM before trying to move machine</p> <p>Fill reservoir to proper level with approved oil; see section on Service and Maintenance</p> <p>Allow for adequate warm-up period</p> <p>Check and replace filter</p> <p>Inspect for collapsed suction hose</p> <p>Replace hydrostatic pump or motor</p> |
| Noisy hydrostatic system | <p>Cold oil</p> <p>Low engine speed</p> <p>Oil level in reservoir low</p> <p>Air in system</p> <p>Internal damage to pump</p> | <p>Allow for adequate warm-up period</p> <p>Increase engine speed</p> <p>Fill reservoir to proper level with approved oil; see section on Service and Maintenance</p> <p>Inspect and tighten all fittings on suction line</p> <p>Replace pump</p> |
| External oil leaks | <p>Loose or faulty fittings</p> <p>Damaged O-ring</p> <p>Faulty hose</p> | <p>Tighten or replace</p> <p>Inspect; if damaged replace</p> <p>Replace hose</p> |

IX. TROUBLE SHOOTING

D. HYDRAULIC SYSTEM



CAUTION

DO NOT GO NEAR LEAKS. High pressure oil easily punctures skin causing injury, gangrene, or death. If injured, seek emergency medical help. Immediate surgery is required to remove oil. Do not use finger or skin to check for leaks. Lower load or relieve hydraulic pressure before loosening fit-

| PROBLEM | POSSIBLE CAUSE | SUGGESTED REMEDY |
|---|---|---|
| Entire hydraulic system fails to function | Oil level in reservoir low | Fill reservoir to proper level with approved oil; see section on Service and Maintenance |
| | Oil not reaching pump | Prime the pump by removing suction hose from reservoir; hold removed end higher than pump; hand feed two (2) quarts approved oil through suction hose by bumping engine w/ starter (careful not to start engine); re-install hose; tighten all fittings |
| | Faulty hydraulic pump | Replace hydraulic pump |
| Noisy hydraulic pump | Collapsed suction hose caused by cold oil | Allow for adequate warm-up period |
| | Oil level in reservoir low | Fill reservoir to proper level with approved oil; see section on Service and Maintenance |
| | Air leak in suction line | Inspect and tighten all fittings on suction hose |

SAFETY/ IDENTIFICATION DECALS
 SPECIFICATIONS
 PREPARING TO OPERATE
 OPERATING INFORMATION
 TRANSPORTING
 SERVICE/ MAINTENANCE
 STORAGE
TROUBLE SHOOTING
 LIMITED WARRANTY
 INDEX

IX. TROUBLE SHOOTING

| PROBLEM | POSSIBLE CAUSE | SUGGESTED REMEDY |
|--|---|--|
| Lifting mechanism won't lift | <p>Bad Cylinder</p> <p>Blown relief valve</p> <p>Relief valve set too low</p> <p>Lift arms frozen</p> <p>Faulty electro-hydraulic valve</p> | <p>Check cylinder; remove and rebuild or replace</p> <p>Remove, check; replace w/ new</p> <p>Reset to 2000 PSI</p> <p>Loosen mounting bolts; lubricate grease fittings if equipped</p> <p>See Tasselrol®/LS and/or Tasselrol® trouble shooting guide</p> |
| Cutter head blades, quad pullers, rollers, or tires won't turn | <p>Oil level in reservoir low</p> <p>Oil not reaching pump</p> <p>Faulty hydraulic pump</p> <p>Faulty hydraulic motor or motors</p> | <p>Fill reservoir to proper level with approved oil</p> <p>Remove suction hose from pump, check for proper flow. Reinstall hose; all suction fittings</p> <p>Replace hydraulic pump</p> <p>Replace motor or motors</p> |
| Hydraulic motor leaking | <p>Seal failure</p> <p>Restricted case drain hose</p> | <p>Replace seal; turn heads on with low engine RPM</p> |

IX. TROUBLE SHOOTING

E. ELECTRICAL

 CAUTION
 Batteries contain sulfuric acid. Avoid contact with skin, eyes, or clothing. Do not inhale fumes or ingest liquid. Batteries contain gases which can explode. Keep sparks and flame away while servicing.

NOTE:
 Disconnect battery when servicing any part of electrical system to prevent system damage.

| PROBLEM | POSSIBLE CAUSE | SUGGESTED REMEDY |
|--|--|---|
| Entire electrical system is dead | Dead battery Poor battery connection Low charging rate No charging rate | Charge or replace Clean and tighten Tighten alternator belt Replace alternator |
| All gauges on instrument panel not working | Blown fuse Poor ground | Replace fuse Clean and tighten ground |
| Tachometer/MPH Indicator not working | Blown fuse Loose connections at sensor/alternator Faulty sensor | Replace fuse Tighten or replace connectors Replace sensor |
| Light system does not function | Blown fuse Poor ground Burned-out bulb Separation or short in wire Faulty switch | Replace fuse Clean and tighten ground Replace bulb Check continuity and replace wire Replace switch |

DETASLER SAFETY/
IDENTIFICATION DECALS

SPECIFICATIONS

PREPARING
INFORMATION TO OPERATE

OPERATING
INFORMATION TO OPERATE

TRANSPORTING

SERVICE/
MAINTENANCE

STORAGE

TROUBLE
SHOOTING

LIMITED
WARRANTY

INDEX

IX. TROUBLE SHOOTING

F. TASSELTROL®/ LS SYSTEM – HYDRAULIC



CAUTION

DO NOT GO NEAR LEAKS. High pressure oil easily punctures skin causing injury, gangrene, or death. If injured, seek emergency medical help. Immediate surgery is required to remove oil. Do not use finger or skin to check for leaks. Lower load or relieve hydraulic pressure before loosening fit-

| PROBLEM | POSSIBLE CAUSE | SUGGESTED REMEDY |
|------------------------------|---|---|
| No units will lift | Oil level in reservoir low Faulty valve Relief valve in electro-hydraulic valve set too low | Fill tank to proper level Repair or replace valve Reset to 2000 PSI |
| No units will lower | All lift arm pivots too tight | Lubricate and loosen pivot points |
| Only one unit will not lower | Faulty valve Lift arm pivot too tight | Replace valve |

IX. TROUBLE SHOOTING

| PROBLEM | POSSIBLE CAUSE | SUGGESTED REMEDY |
|--------------------------------------|--|---|
| All units lift slowly | <p>Hydraulic oil not at operating temperature</p> <p>Faulty valve</p> <p>Lift arm pivots too tight</p> <p>Plugged high pressure filter</p> <p>Raise orifice in valve adjusted incorrectly</p> <p>Relief valve in electro-hydraulic valve set too low</p> | <p>Allow time for oil to warm up</p> <p>Replace valve</p> <p>Lubricate and loosen pivot point</p> <p>Remove, clean, replace (see page 84)</p> <p>Re-adjust orifice</p> <p>Reset to 2000 PSI</p> |
| Only one unit lifts slowly | <p>Faulty valve</p> <p>Lift arm pivots too tight</p> <p>Raise orifice in valve adjusted incorrectly</p> | <p>Replace valve</p> <p>Lubricate and loosen pivot point</p> <p>Re-adjust orifice (see page 44)</p> |
| Only one unit will not hold position | <p>Oil leak between valve and cylinder</p> <p>Faulty valve</p> <p>Faulty lower poppet on stack valve</p> | <p>Repair leak or replace hose</p> <p>Replace valve</p> <p>Remove, clean, replace</p> |
| No units will hold position | Problem is not hydraulic | See Tasseltrol® – elect. section |

SAFETY /
DETASSELER IDENTIFICATION DECALS

SPECIFICATIONS

PREPARING TO OPERATE

OPERATING INFORMATION

TRANSPORTING

SERVICE / MAINTENANCE

STORAGE

TROUBLE SHOOTING

LIMITED WARRANTY

INDEX

IX. TROUBLE SHOOTING

| PROBLEM | POSSIBLE CAUSE | SUGGESTED REMEDY |
|--|--|--|
| Only one unit lowers slowly | Faulty valve Faulty lower poppet on stack valve Lower orifice incorrectly adjusted | Replace valve Remove, clean, replace Re-adjust orifice (see page 44) |
| All units lower slowly | Hydraulic oil not at operating temperature | Allow time for oil to warm up |
| In "Manual" mode, more than one unit lifts or lowers from one up/down switch | Faulty valve | Replace valve |
| In "Auto" mode, more than one unit raises from photo sensor | Faulty valve | Replace valve |
| In "Auto" mode, wrong unit raises from photo sensor | Cylinder hoses are connected to | Attach correct hose to proper cylinder |

IX. TROUBLE SHOOTING

G. TASSELTROL® / LS SYSTEM – ELECTRICAL

NOTE:
Disconnect battery when servicing any part of electrical system to prevent system damage.

| PROBLEM | POSSIBLE CAUSE | SUGGESTED REMEDY |
|-----------------------------|---|---|
| No units will lift | Faulty "AUTO/MANUAL" switch | Replace control box |
| | Blown fuse | Find short in wire, repair and replace fuse |
| | Faulty #1 valve, coil, or loose coil mounting nut | Tighten nut or replace coil |
| | Loose wire connections | Find loose connections, tighten |
| | Faulty wire connections | Replace or repair |
| | Faulty main wire assembly | Replace or repair |
| Only one unit will not lift | In "MANUAL" mode: faulty "UP/DOWN" switch | Replace control box |
| | Light photo sensor assembly | Replace photo sensor |
| | Faulty valve, coil, or loose coil mounting unit | Tighten nut or replace coil |
| | Loose wire connections | Find loose connections, tighten |
| | Lights photo sensor not lined up with reflector | Line up sensor with reflector |
| | Faulty row wire assembly | Replace or repair |
| | Faulty sensor connector wire assembly | Replace or repair |

SAFETY/ IDENTIFICATION DECALS
 SPECIFICATIONS
 PREPARING INFORMATION TO OPERATE
 OPERATING INFORMATION TO OPERATE
 TRANSPORTING
 SERVICE/ MAINTENANCE
 STORAGE
TROUBLE SHOOTING
 LIMITED WARRANTY
 INDEX

IX. TROUBLE SHOOTING

| PROBLEM | POSSIBLE CAUSE | SUGGESTED REMEDY |
|--|---|---|
| No units will lower | <p>Faulty "AUTO/MANUAL" switch</p> <p>Blown fuse</p> <p>Loose wire connections</p> <p>In "AUTO" mode: LS valve assembly unplugged</p> | <p>Replace control box</p> <p>Find short in wire, repair and replace fuse</p> <p>Find loose connections, tighten</p> <p>Plug in wire assembly</p> |
| Only one unit will not lower | <p>Faulty "UP/DOWN" switch</p> <p>In "AUTO" mode: faulty light sensor assembly</p> <p>Loose wire connections</p> <p>Faulty valve coil or loose coil mounting unit</p> <p>Faulty sensor connector wire assembly</p> <p>In "AUTO" mode: light sensor not lined up with reflector</p> <p>Faulty row LS wire assembly</p> | <p>Replace control box</p> <p>Replace sensor</p> <p>Find loose connections, tighten</p> <p>Tighten nut or replace coil</p> <p>Replace or repair</p> <p>Line up sensor with reflector</p> <p>Replace or repair</p> |
| No units will hold position | <p>In "AUTO" mode: no crop moving under sensor assemblies</p> | <p>Drive forward or select "MANUAL" mode</p> |
| In "AUTO" mode, wrong unit raises from sensor assembly | <p>Row LS wire assembly plugged into wrong sensor connector</p> | <p>Plug correct wire assembly into proper row sensor connector assembly</p> |

IX. TROUBLE SHOOTING

TASSELTROL® DISPLAY TROUBLESHOOTING

To gain further information on the status of the Tasselrol®/LS system before operation: while sitting in the operator's seat, turn the ignition key to the "ON" position (do not start the engine); turn the Tasselrol® box to the "ON" position; turn the "AUTO/MANUAL" switch to "MANUAL."

Make sure there is nothing physically blocking any upper or lower sensor's path to its reflector.

The display will show the status of the upper and lower photo sensor on each lift assembly. If the display shows a box ("□") in all upper and lower areas, the unit is ready for operation. If the display shows a corn stalk ("Ÿ") in one or more areas, refer to pages 113-114 for further suggested remedies.

The LEFT-CENTER sensors are used as examples.

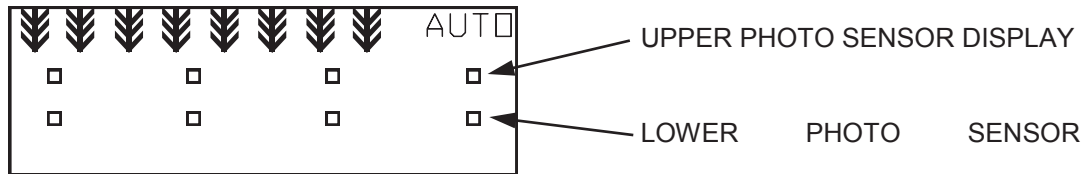

TASSELTROL® DISPLAY

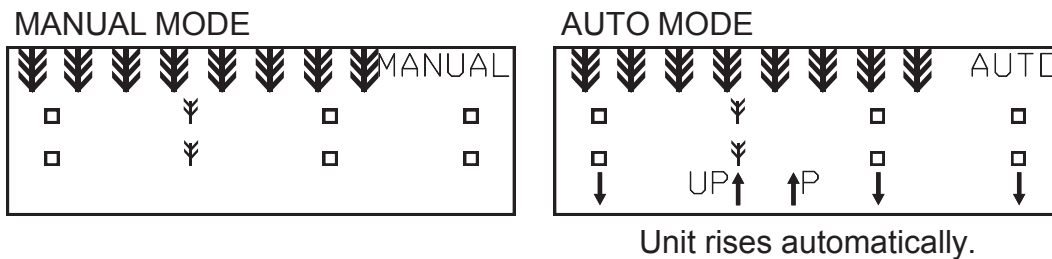

| PHOTO SENSOR STATUS LIGHTS | POSSIBLE CAUSE |
|----------------------------------|---|
| Lights at both photo sensors | Photo sensors not in line with reflector (See page 34) |
| No lights at either photo sensor | Faulty connector cable (See page 118, fig. 9.1, item 2) Faulty RED and/or BLACK wire in connector cable (See page 118, fig. 9.1, item 1) |

SAFETY/ IDENTIFICATION DECALS
 SPECIFICATIONS
 PREPARING TO OPERATE
 OPERATING INFORMATION
 TRANSPORTING
 SERVICE/ MAINTENANCE
 STORAGE
 TROUBLE SHOOTING
 LIMITED WARRANTY
 INDEX

IX. TROUBLE SHOOTING

TASSELTROL® DISPLAY

MANUAL MODE

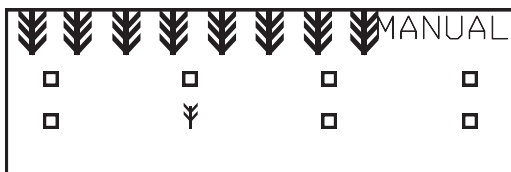

AUTO MODE

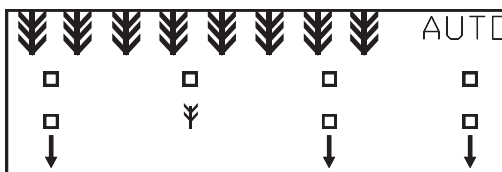

Unit does NOT rise automatically.

| PHOTO SENSOR STATUS LIGHTS | POSSIBLE CAUSE |
|---------------------------------|---|
| Lights at lower photo sensor | <p>Faulty GREEN wire in connector cable (See page 118, fig. 9.1, item 2)</p> <p>Photo sensor not in line with reflector (See page 34)</p> <p>Faulty BLUE wire in sensor assembly (See page 118, fig. 9.1, item 1)</p> |
| No lights at lower photo sensor | <p>Faulty RED and/or BLACK wire in connector cable (See page 118, fig. 9.1, item 2)</p> |

IX. TROUBLE SHOOTING

TASSELTROL® DISPLAY

MANUAL MODE

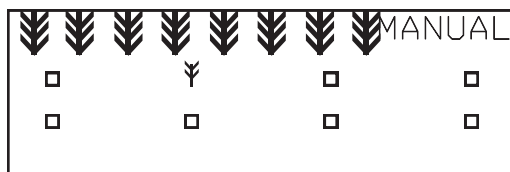

AUTO MODE

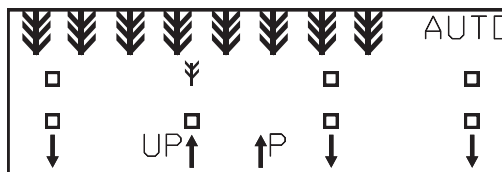

Unit rises automatically.

| PHOTO SENSOR STATUS LIGHTS | POSSIBLE CAUSE |
|---------------------------------|---|
| Lights at upper photo sensor | Faulty WHITE wire in sensor assembly (See page 118, fig. 9.1, item 1) Faulty BLUE wire in sensor assembly (See page 118, fig. 9.1, item 1) |
| No lights at upper photo sensor | Faulty RED and/or BLACK wire in connector cable (See page 118, fig. 9.1, item 2) |

SAFETY/ IDENTIFICATION DECALS
 DETASSELER IDENTIFICATION DECALS
 SPECIFICATIONS
 PREPARING TO OPERATE
 OPERATING INFORMATION TO OPERATE
 TRANSPORTING
 SERVICE/ MAINTENANCE
 STORAGE
 TROUBLE SHOOTING
 LIMITED WARRANTY
 INDEX

IX. TROUBLE SHOOTING

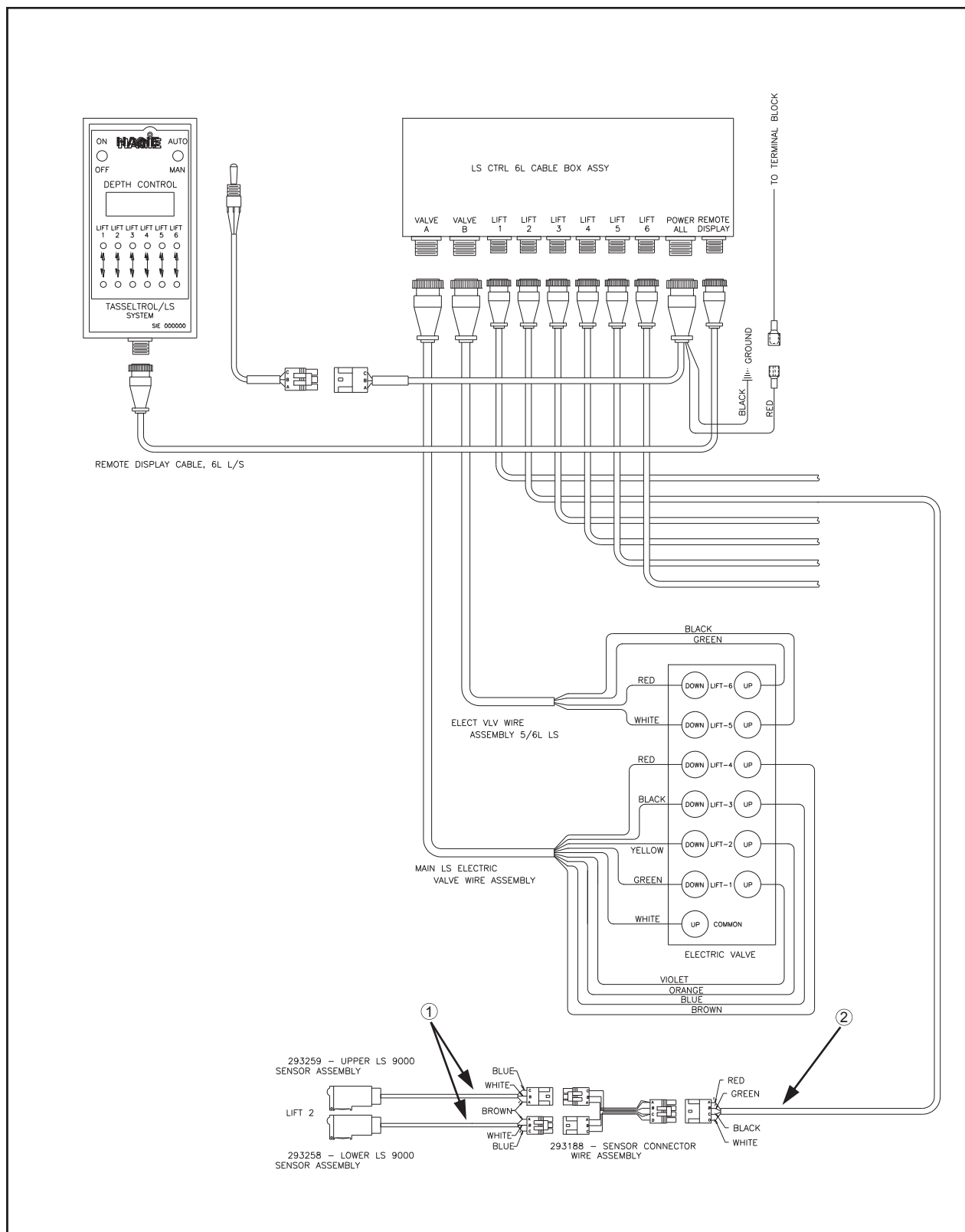

FIG 9.1

X. LIMITED WARRANTY

1. The Warranty

- a. This warranty gives you specific legal rights. You may also have other rights which may vary from state to state.
- b. Hagie makes this warranty only to the original purchaser of its new equipment.
- c. The warranty period ends 12 months from the date of delivery of equipment to the original purchaser. When requesting warranty service, the original purchaser must present evidence of the date of delivery of the equipment.
- d. Parts or rebuilt assemblies furnished under the terms of this warranty are not warranted beyond the original warranty period.
- e. Exceptions to this warranty must be covered by separate warranty agreements.

2. Items not covered by Hagie Warranty

- a. Used equipment.
- b. Tires, tubes, engines, and batteries (under separate manufacturer's warranty).
- c. Depreciation or damage caused by normal wear, accident, improper maintenance, improper storage, or improper use.
- d. Service calls and transporting the equipment to and from the place where the warranty work is performed.

3. Unapproved service or modification

NOTE:

All obligations of Hagie Manufacturing Company under this warranty shall be terminated if:

- a. . . . service is performed by someone other than Hagie authorized personnel.
or
- b. . . . the equipment is modified or altered without Hagie approval.

4. No commercial loss coverage

- a. Hagie shall not be liable for incidental or consequential damages or injuries (damage and repairs of equipment itself, loss of profits, rental or substitute equipment, loss of good will, etc.).
- b. SOME STATES DO NOT ALLOW THE EXCLUSION OR LIMITATION OF INCIDENTAL OR CONSEQUENTIAL DAMAGES, SO THE ABOVE LIMITATION MAY NOT APPLY TO YOU.

5. Merger clause

- a. The entire warranty agreement is included in this writing.
- b. Any oral agreements that are made by the selling persons about the equipment are not warranties, and are not to be relied upon by the purchaser.

6. No representations or implied warranty

- a. The parties agree that the implied warranties of merchantability and fitness for a particular purpose and all other warranties expressed or implied, are excluded from this transaction and shall not apply to the equipment sold.

SAFETY/
DETAILED IDENTIFICATION
DECALS

SPECIFICATIONS

PREPARING
TO OPERATE

OPERATING
INFORMATION

TRANSPORTING

SERVICE/
MAINTENANCE

STORAGE

TROUBLE
SHOOTING

LIMITED
WARRANTY

INDEX

INDEX

| | PAGE | | PAGE |
|--|-------|---|-------|
| A | | D | |
| Adjusting | | Depth Command | |
| Cab Climate Controls..... | 68 | Attaching..... | 35 |
| Detasseling Depth..... | 45 | Fuse..... | 90 |
| Toe-In..... | 97 | Operating..... | 58 |
| Tread Width..... | 23-24 | Driving Instruction | 71 |
| Air Conditioning System | | Driving Safety | 4 |
| Belt..... | 92 | | |
| Cab Filters..... | 85 | E | |
| Charging System..... | 81 | Electrical System | 88-91 |
| Climate Controls..... | 68 | Electro-Hydraulic Valve | 44 |
| Dryer..... | 84 | Engine | |
| Vents..... | 68 | Cold Weather Starting..... | 39 |
| Antifreeze | 79 | Fuel | |
| Attaching | | Filters..... | 85 |
| Cutter Heads..... | 31-33 | Type..... | 80 |
| Depth Command..... | 35 | Oil..... | 77 |
| Lift Arm Assemblies..... | 28 | Operation..... | 38-39 |
| LS System..... | 34 | Engine Oil Pressure Gauge | 59 |
| Male Corn Choppers..... | 36 | Emergency Exit, Cab | 67 |
| Male Corn Cutters..... | 37 | | |
| Outrigger Options..... | 26-27 | F | |
| Quad Pullers..... | 29-30 | Filter Minder ®..... | 59 |
| | | Filters | |
| B | | Air Conditioning Dryer..... | 84 |
| Battery | 88 | Cab..... | 85 |
| Belts | 92 | Engine Air Intake Filter..... | 82 |
| Bolt Torque Values | | Fuel Filters..... | 85 |
| Leg Mounting Bolts..... | 95 | Hydraulic Charge Pressure Filter..... | 83 |
| Wheel Lug Nuts..... | 94 | Hydraulic High-Pressure In-Line Filter..... | 84 |
| Bottom Parameter, Tasselrol ®..... | 54 | Hydraulic Return Filter..... | 83 |
| | | Hydraulic Suction Filter..... | 83 |
| C | | Radiator Grille Screens..... | 83 |
| Cab | | Fresh Air Intake Filter, Cab | 85 |
| Climate Controls..... | 68 | Fluid Capacities | 81 |
| Emergency Exit..... | 67 | Fluids | |
| Filters..... | 85 | Air Conditioning Charge..... | 81 |
| Seat Operation | | Cooling System Coolant..... | 79-80 |
| Cab..... | 69 | Engine Oil..... | 77 |
| Standard Operator Station..... | 62 | Fuel..... | 80 |
| Charcoal Filter, Cab | 85 | Hydraulic Oil..... | 77 |
| Charge Pressure Filter, Hydraulic | 83 | Torque Hub® Oil..... | 78 |
| Choppers, Male Corn | | Fuel Filters | 85 |
| Attaching..... | 36 | Fuel Gauge | 59 |
| Lubrication..... | 87 | Fuel Safety | 6 |
| Circuit Breakers | | Fuel Tank Selector Switch | 63 |
| Control Panel..... | 91 | Fuses | |
| Wire Harnesses..... | 91 | Control Panel..... | 89 |
| Climate Controls, Cab | 68 | Depth Command..... | 90 |
| Cold Weather Starting | 39 | | |
| Cooling System | | G | |
| Coolant..... | 79 | Gauges | 59 |
| Radiator Grille Screens..... | 83 | Ground Speed Sensor | 60 |
| Cutters | | | |
| Attaching..... | 31-33 | H | |
| Operating..... | 47 | High Pressure In-Line Filter | 84 |
| | | Hour Meter | 59 |

INDEX

| | PAGE | | PAGE |
|---|-------|--|--------|
| Hydraulic Filters | | Programming | |
| Charge Pressure..... | 83 | Speedometer..... | 60 |
| Return..... | 83 | Tachometer..... | 60 |
| Suction..... | 83 | Tasseltrol®..... | 48-56 |
| Hydraulic Safety | 6 | | |
| Hydrostatic Drive System | | Q | |
| Charge Pressure..... | 40 | Quad Pullers | |
| Operation..... | 40 | Attaching..... | 29-30 |
| Pump | | Lubrication..... | 87 |
| Neutral Setting..... | 93 | Operating..... | 47 |
| Service..... | 93 | | |
| I | | R | |
| Instrument Panel Gauges | 59 | Radiator Grille Screens | 83 |
| L | | Radio | 70 |
| Lift Arm Assemblies | 28 | Repair/Maintenance Safety | 6 |
| Lift Cylinders | 45 | Response Parameter, Tasseltrol® | 52 |
| Lift Arm Stack Valve | 44 | Return Filter, Hydraulic | 83 |
| Lights | | | |
| Halogen Work Lights..... | 64 | S | |
| Hazard/Warning Lights..... | 65 | Safety | 4-6 |
| Interior Lights, Cab..... | 70 | Seat | |
| Running Lights..... | 65 | Comfort Controls | |
| Turn Signal..... | 65 | Cab..... | 69 |
| Light Sensing (LS) System | 48-57 | Standard..... | 62 |
| Lubrication | | Seal Boot, Torque Hub® | 86 |
| Four Blade Male Corn Cutter..... | 87 | Serial Number Locations | 14-15 |
| Leg Bearings..... | 86 | Service Intervals | 74-76 |
| Male Corn Chopper..... | 87 | Service/Maintenance | 73-100 |
| Quad Puller..... | 87 | Specifications | 16-22 |
| Torque Hub® Seal Boots..... | 86 | Speed Sensor | 60 |
| Lug Nuts | 94 | Speedometer | 60 |
| M | | Stack Valve | 44 |
| Maintenance Safety | 6 | Steering | |
| Maintenance Schedule | 73 | Column Tilt..... | 63 |
| Male Corn Choppers | | Toe-In..... | 96 |
| Attaching..... | 36 | Suction Filter, Hydraulic | 83 |
| Lubricating..... | 87 | | |
| Male Corn Cutters | | T | |
| Four-Blade | | Table of Contents | 3 |
| Lubrication..... | 87 | Tachometer | 60 |
| Single-Blade | | Tasseltrol® | |
| Attaching..... | 37 | Operating..... | 49 |
| O | | Programming | |
| Operating Information | 38-70 | All Up Dwell..... | 51 |
| Oil Pressure Gauge, Engine | 59 | Bottom Parameter..... | 54 |
| Operating Safety | 5 | Response Parameter..... | 52 |
| P | | Top Parameter..... | 53 |
| Parking Brake | 41 | Tires | |
| Prepare to Operate | 23-37 | Air Pressure..... | 99 |
| Preoperation Checks | 38 | Filling..... | 99 |
| | | Mounting..... | 99 |
| | | Specifications..... | 21 |
| | | Toe-In | |
| | | Adjusting..... | 97 |
| | | Measuring..... | 96 |

DETASLER SAFETY/
IDENTIFICATION DECALS

SPECIFICATIONS

PREPARING
INFORMATION TO OPERATE

OPERATING
INFORMATION TO OPERATE

TRANSPORTING

SERVICE/
MAINTENANCE

STORAGE

TROUBLE
SHOOTING

LIMITED
WARRANTY SHOOTING

INDEX

INDEX

| | PAGE | | PAGE |
|--|---------|---|---------|
| Top Parameter, Tasselrol® | 53 | V | |
| Torque Hubs® | | Volt Meter | 59 |
| Core Exchange | 93 | W | |
| Oil Level | 78 | Warning Decal Location | 7-13 |
| Seal Boot Lubrication | 86 | Warning Symbol Definitions | 2 |
| Torque Values | | Warranty | 119 |
| Leg Mounting Bolts | 95 | Water Temperature Gauge | 59 |
| Wheel Lug Nuts | 94 | Wheel Lug Nuts | 94 |
| Transporting Detasseler | 71-72 | Windshield Wiper | 70 |
| Tread Width | 23 | Winter Storage Directions | 101-102 |
| Trouble Shooting Guide | 103-118 | | |

NOTES
