

PARTS MANUAL
FOR
HAGIE MODEL 204 DETASSELER

HAGIE MANUFACTURING COMPANY

BOX 273 CLARION, IOWA 50525 (515) 532-2861

COVERS MACHINE SERIAL NUMBERS: 052059001 thru 052059200

05-95 493150
02-08

DETASSELER IDENTIFICATION

Each Hagie detasseler is identified by means of a frame serial number. This serial number denotes the model, the year in which it was built, and the number of the detasseler. As for further identification, the engine has a serial number, the hydrostatic pump has a serial number, the wheel motors have identification tags, and the planetary hubs have identification plates that describe the type of mount and gear ratio. To insure prompt, efficient service when ordering parts or requesting service repairs from Hagie Manufacturing Company, record the serial and identification numbers in the space provided below.

NOTE: Reference to left hand and right hand used throughout this manual refers to the position when seated in the operator's seat facing forward.

DETASSELER SERIAL NUMBER

ENGINE SERIAL NUMBER

PLANETARY HUB IDENTIFICATION NUMBERS

TABLE OF CONTENTS

ENGINE ASSEMBLIES	4-8
HI-PRESS FILTER & LOOP FLUSHING VALVE	9-10
FLOW DIVIDER.11
POSITRACION VALVE.	12-13
EXHAUST PIPE & AIR CLEANER.	14-17
RADIATOR AND OIL COOLER18
LEG ASSEMBLIES.	19-22
TIRE AND STALK GUIDE.	23-24
LADDER AND SERVICE PLATFORM25
TIE ROD ASSEMBLY.26
STEERING CYLINDER ASSEMBLY.27
FUEL AND OIL TANKS.	28-31
CANOPY ASSEMBLY32
OPERATOR STATION ASSEMBLY	33-36
INSTRUMENT PANEL ASSEMBLY37
CONSOLE ASSEMBLY.	38-41
SHEET METAL	42-43
BATTERY44
MOTOR CONTROL VALVE45
RETURN FILTER46
OUTRIGGER AND LIFT ASSEMBLY	47-51
ELECTROHYDRAULIC VALVE.	52-53
ROLLER AND CUTTER HEAD.	54-55
QUAD AND TIRE PULLER HEAD	56-57
MALE ROW CHOPPER.	58-61
CONTROL BOX ASSEMBLY.62
LS COMPONENTS63
DEPTH COMMAND	64-65
T-TROL\LS RECEPTACLE.66
WHEEL DRIVE ASSEMBLY.	67-69
DECALS.	70-71
WIRING DIAGRAM.	72-75
ELECTRICAL SCHEMATIC.	76-85
HYDRAULIC SCHEMATIC86-121
ABBREVIATIONS	122
INDEX	123

CHRYSLER ENGINE ASSEMBLY

DET. QTY PART NO. DESCRIPTION

1	1	147000	BELT GATES 2490 TRUFLEX	
2	1	147001	BELT GATES 7512	
3	3	200015	.75 OD X 11GA WA X .38LG C/L	
4	1	291487	72 AMP ALT W/ REGULATOR	
5	1	314303	EXHAUST MANIF HEAT SHIELD	
6	1	314309	ALT ADJ ARM	
7	1	314359	FAN SPACER CHRY 383014	
8	1	314832	RADIATOR HOSE 1.75 X 19	
9	1	314841	COIL WIRE FOR CHRY 318	
10	1	314849	CHRY 72A ALT MT WLD	90
11	1	314852	CHRY 72A ALT MT SLV PRESTO	90
12	1	341793	RH FRT MTR MT WLD 200 318	89
13	1	341794	LH FRT MTR MT WLD 200 318	89
14	2	341797	REAR MTR MT WLD 200 318	89
15	1	341815	HYDST CABLE MT 200 CHRY 318	
16	2	520070	HOSE CLAMP NO 8 PLATED	
17	1	520085	HOSE CLAMP NO 24 PLATED	
18	2	520120	HOSE CLAMP NO 4 PLATED MINI	
19	1	601151	HOSE, 5/8 X 12 HEATER	
20	2	900002	1/4UNC X 3/4 HEX BOLT	
21	6	900064	5/16UNC X 3/4 HEX BOLT	
22	1	900065	5/16UNC X 1 HEX BOLT	
23	4	900069	5/16UNC X 2 HEX BOLT	
24	1	900132	3/8UNC X 1 3/4 HEX BOLT	
25	2	900142	3/8UNC X 5 HEX BOLT	
26	4	900198	7/16UNC X 1 3/4 HEX BOLT	
27	2	900283	1/2UNC X 2 1/4 HEX BOLT	
28	2	914000	1/4UNC HEX STOVER NUT	
29	4	914006	7/16UNC HEX STOVER NUT	
30	6	914008	1/2UNC HEX STOVER NUT	
31	1	920001	5/16 FLAT WASHER SAE PLT	
32	6	920004	1/2 FLAT WASHER SAE	
33	11	920501	LOCK WASH 5/16	
34	1	316180	22 IN DIA 6 BLADE 2.25 PITCH	
35	1	314824	3GR CRANK PULLEY CHRY 318	
36	1	314388	FUEL LINE W/ FILT CHRY 318	
37	1	319260	PH8 FRAM FILT OIL	
38	1	900137	3/8UNC X 3 1/4 HEX BOLT	
39	1	914004	3/8UNC HEX STOVER NUT	
40	1	314417	LWR RAD HOSE 8240 82 318 CHRY	
41	1	314428	CABLE HEAT SHLD WLD CHRY 318	
42	3	520067	HOSE CLAMP NO 28 PLATED	
43	4	900265	1/2UNC X 1 1/2 HEX BOLT	
44	1	314437	TEMP SENDR 280D 1/8NPT FOR GA	
45	1	520128	CUSH HOSE CLAMP 9/16D X 3/4W	
46	1	314853	CHRY ALT FRONT BUSH PRESTO	90
47	1	314854	CHRY ALT REAR BUSH PRESTO	90
48	2	193012	QUICKEDGE TRIM .135 TO .250	
49	1	920002	WASH FLAT 3/8 SAE	

4

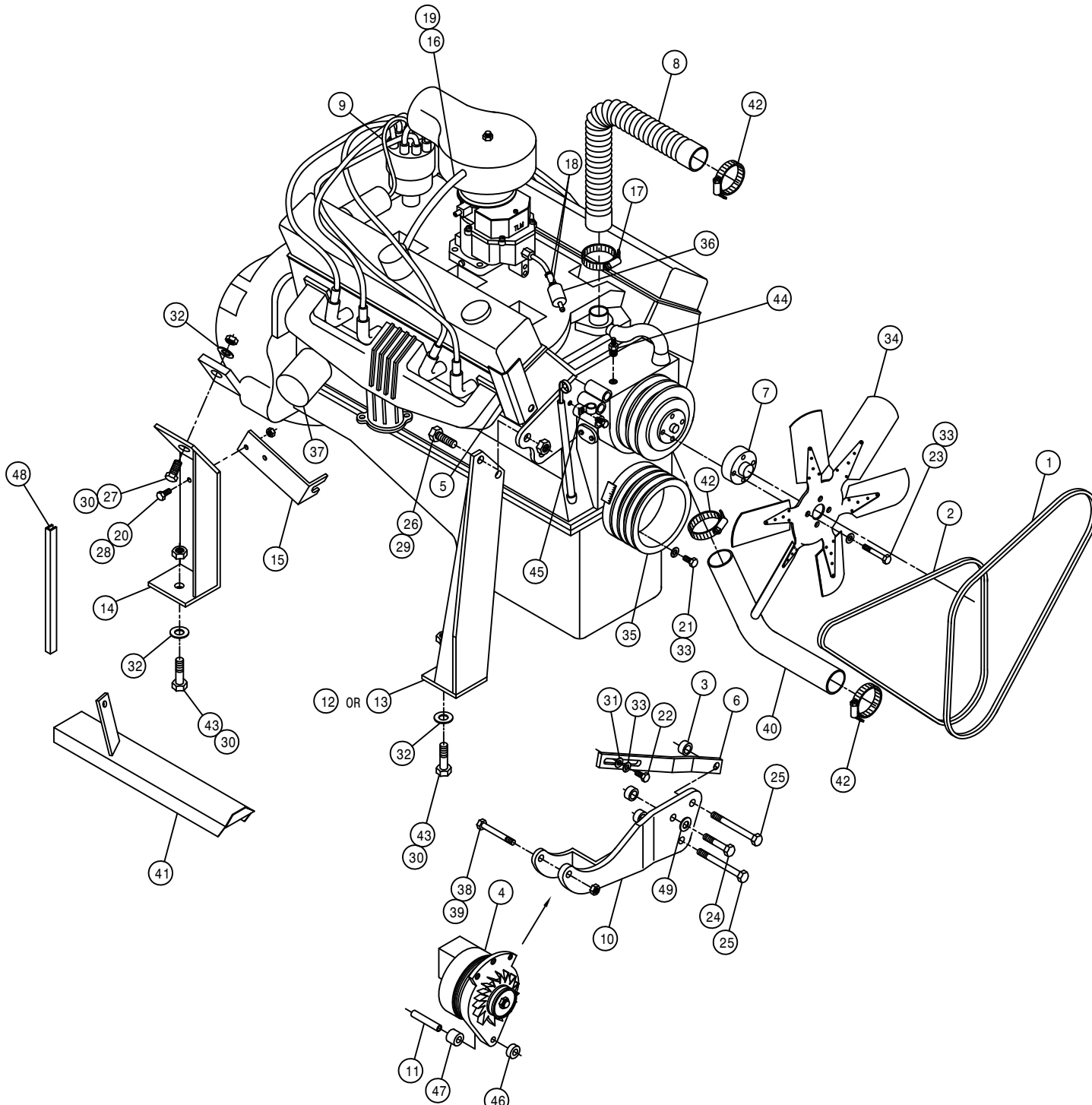

150004

5

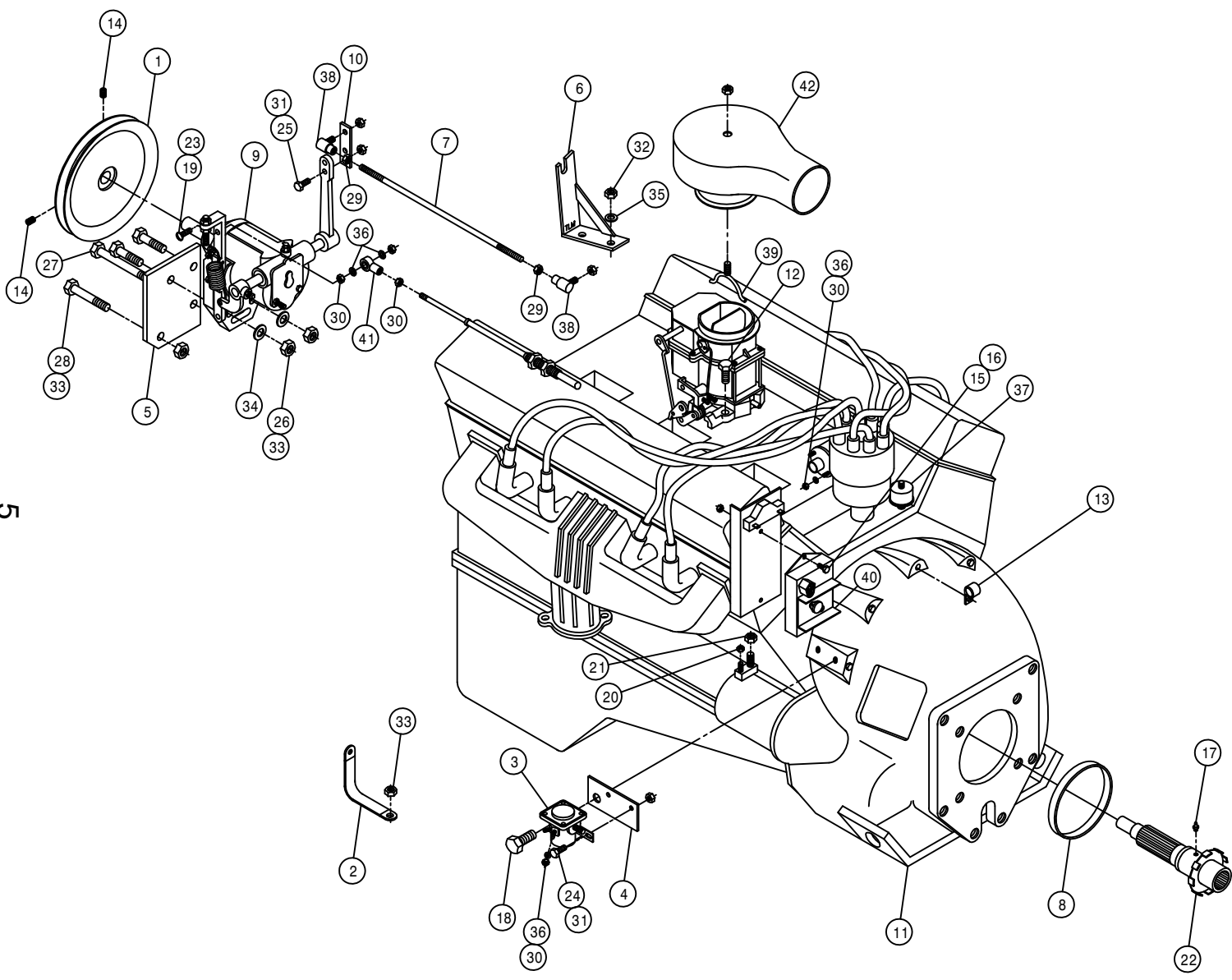

CHRYSLER ENGINE ASSEMBLY

DET.	QTY	PART NO.	DESCRIPTION
1	1	147030	6IN PULLEY A GR 5/8 BORE
2	1	290109	GROUND STRAP, 8IN 17/32 HOLES
3	1	310491	STARTER SOLENOID FORD 300 ENG
4	1	311021	START SOLENOID MT 473 CHRY
5	1	311044	GOV MT WLD
6	1	314918	THROT CABLE BRKT WLD CHRY 93
7	1	314311	GOV CONTROL ROD
8	1	314323	SUND PUMP SPACER RING 647 3/8
9	1	314337	GOV REWORKED 647
10	1	314341	GOV ARMEXTENSION647CHRY
11	1	314922	CHRY ENGINE 5.2L 93
12	4	900065	5/16UNC X 1 HEX BOLT
13	1	520128	CUSH HOSE CLAMP 9/16D X 3/4W
14	2	470054	SET SCREW 5/16X 1/4 AL HD CUP
15	2	470121	1/4UNC HEX FLANGED LOCK NUT
16	2	470122	1/4UNC X 1/2 FLANGED HEX BOLT
17	1	471005	1/4 28 X 1/2 GREASE ZERK
18	1	900262	1/2UNC X 3/4 HEX BOLT
19	1	903893	10 32 X 1 SLT RD HD MACH SCR
20	1	473770	05MM-.80 HEX NUT
21	1	473778	08MM-1.25 HEX NUT
22	1	800490	CHRY 318 OUTPUT SHFT WLD 14T
23	1	914027	#10-32 HEX STOVER NUT
24	2	900000	1/4UNC X 1/2 HEX BOLT
25	2	900002	1/4UNC X 3/4 HEX BOLT
26	2	900131	3/8UNC X 1 1/2 HEX BOLT
27	1	900142	3/8UNC X 5 HEX BOLT
28	1	900170	3/8UNC X 2 1/4 HEX BOLT
29	2	910001	1/4UNF HEX NUT
30	6	910027	#10-32 HEX NUT
31	4	914000	1/4UNC HEX STOVER NUT
32	2	914002	5/16UNC HEX STOVER NUT
33	4	914004	3/8UNC HEX STOVER NUT
34	2	920002	WASH FLAT 3/8 SAE
35	2	920501	LOCK WASH 5/16
36	6	920510	LOCK WASH NO 10
37	1	291610	OIL PRESS SENDER, 1/8NPT
38	2	473918	BALL JOINT 1/4 28 FEM STUDED
39	1	314649	AIRINTK CLAMP FOR 314453 CARB
40	1	314362	ELECT IGN MODULATOR 647
41	1	473921	BALL JOINT NO 10-32 THD
42	1	314500	AIR HORN, CHRY 5.2L ENG

CUMMINS ENGINE ASSEMBLY

DET. QTY PART NO. DESCRIPTION

DET.	QTY	PART NO.	DESCRIPTION
1	1	290107	ENG TO GROUND STRAP 8 IN
2	1	291610	OIL PRESS SENDER, 1/8NPT
3	1	316185	CUMMINS ENGINE 6B5.9
4	1	316252	RH REAR ENG MT WLD, CUMM 94
5	1	316253	LH REAR ENG MT WLD, CUMM 94
6	1	316198	THROTTLE CABLE MT 6CYL CUMM92
7	8	473775	12MM-1.75 X 30MM HEX BOLT
8	8	473784	LOCKWASHER 12MM PL
9	1	618611	1/8FNPT-3/16 TUBE ADPTR,BRASS
10	1	711001	1/8 NPT X 5/16 HOSE BARB
11	1	193012	QUICKEDGE TRIM .135 TO .250
12	1	800495	PERK TO SUND DRIVE ASSY 14T
13	12	473792	10MM-1.50 X 30MM HEX BOLT
14	8	473793	10MM-1.50 X 20MM HEX BOLT
15	20	473798	LOCKWASHER 10MM PL
16	2	520120	HOSE CLAMP NO 4 PLATED MINI
17	2	311054	RUBBER MOUNT SET, CB-2202-4
18	1	473921	BALL JOINT NO 10-32 THD
19	2	910027	#10-32 HEX NUT
20	2	311055	REBOUND WASHER FOR 311054
21	2	470121	1/4UNC HEX FLANGED LOCK NUT
22	2	900271	1/2UNC X 3 1/4 HEX BOLT
23	1	903893	10 32 X 1 SLT RD HD MACH SCR
24	2	914008	1/2UNC HEX STOVER NUT
25	1	914027	#10-32 HEX STOVER NUT
26	2	920004	1/2 FLAT WASHER SAE
27	2	920510	LOCK WASH NO 10
28	1	316208	FUEL FILTER, PRIMARY CUMM 92
29	1	316209	FUEL FILTER, SECONDARY CUMM92
30	2	470118	1/4UNC X 3/4 FLANGED HEX BOLT
31	1	503700	PIPE PLUG .50NPT SQ HD

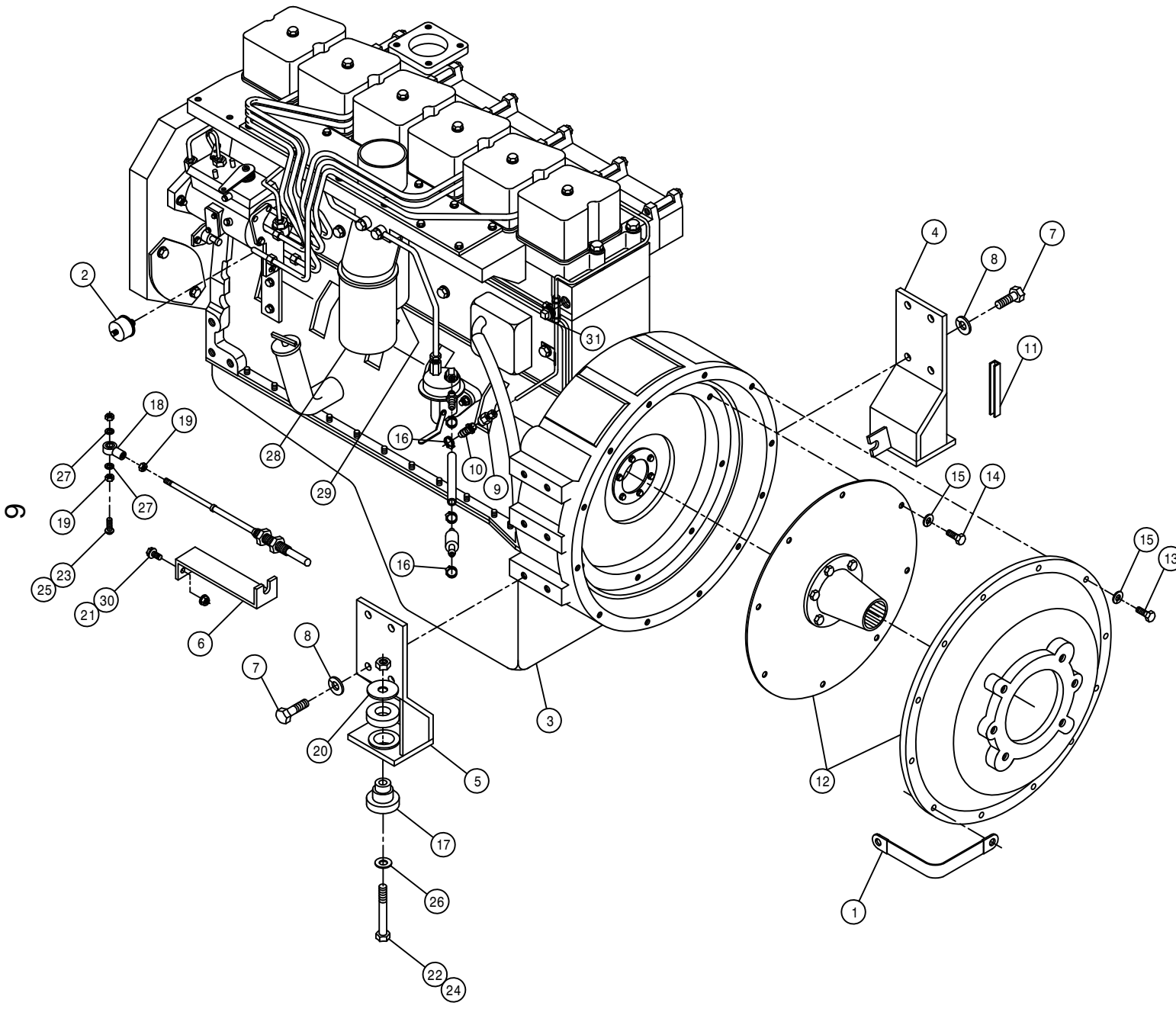

CUMMINS ENGINE ASSEMBLY

DET. QTY PART NO. DESCRIPTION

DET.	QTY	PART NO.	DESCRIPTION
1	1	314836	TEMP SENDR 280D 1/2NPT FOR GA
2	1	316185	CUMMINS ENGINE 6B5.9
3	1	316180	22 IN DIA 6 BLADE 2.25 PITCH
4	1	316250	RH FRT ENG MT WLD, CUMM 94
5	1	316251	LH FRT ENG MT WLD, CUMM 94
6	1	316199	22IN FAN SPACER CUMM 92
7	6	473775	12MM-1.75 X 30MM HEX BOLT
8	6	473784	LOCKWASHER 12MM PL
9	4	473804	8MM LOCKWASHER
10	4	473822	08MM-1.25 X 70MM HEX BOLT
11	1	316206	POLY V BELT CUMMINS DIESEL 92
12	1	316207	LUBE FILTER CUMMINS DIESEL 92
13	2	311053	RUBBER MOUNT SET,SSB26-1000-1
14	1	314832	RADIATOR HOSE 1.75 X 19
15	1	314886	RADIATOR HOSE 2 1/4 20717
16	4	900265	1/2UNC X 1 1/2 HEX BOLT
17	1	193012	QUICKEDGE TRIM .135 TO .250
18	2	520067	HOSE CLAMP NO 28 PLATED
19	2	520099	HOSE CLAMP NO 40 PLATED
20	2	900271	1/2UNC X 3 1/4 HEX BOLT
21	6	914008	1/2UNC HEX STOVER NUT
22	6	920004	1/2 FLAT WASHER SAE
23	1	341968	TIE PLT 250/280 CUMM 92

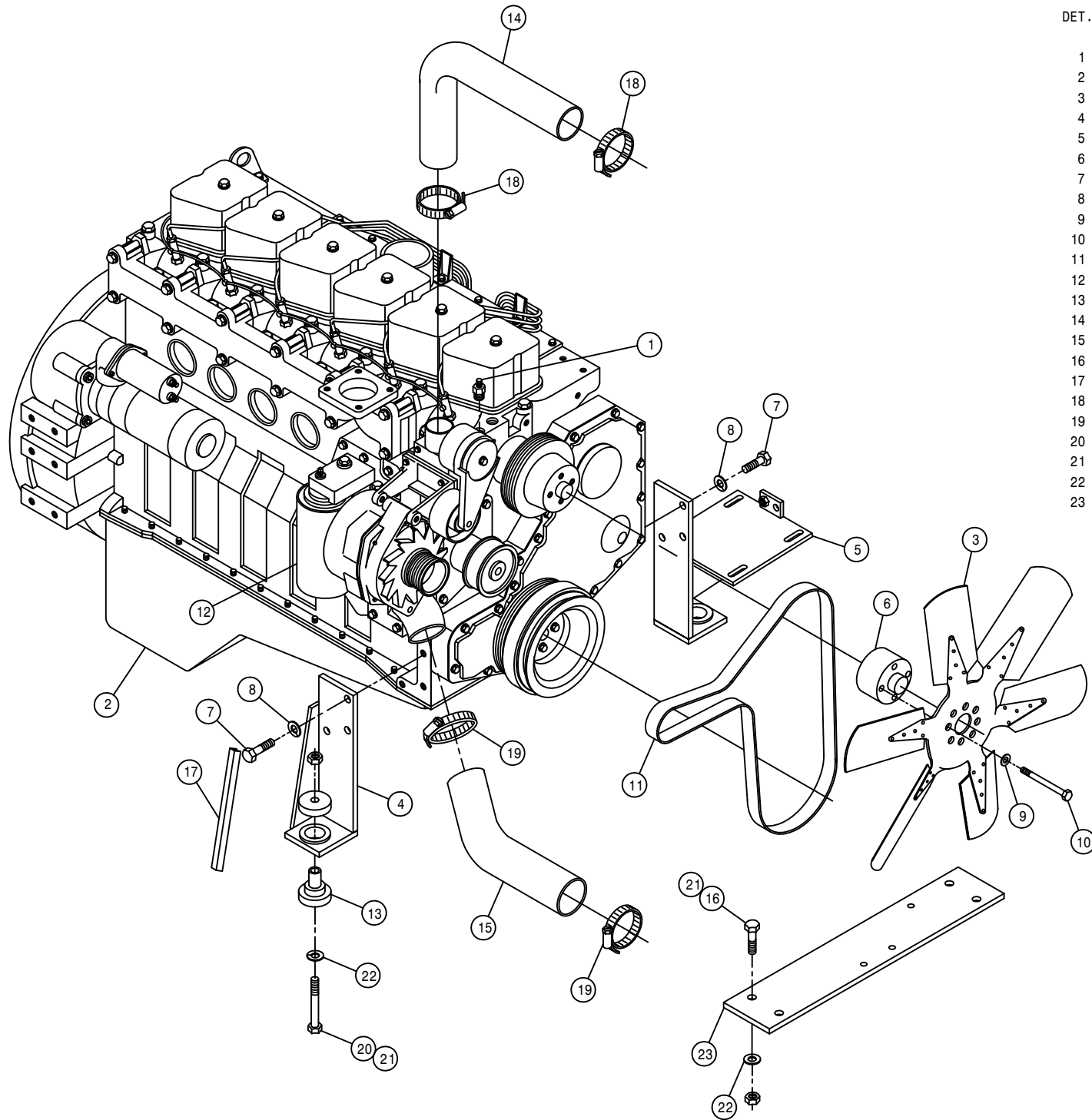

7

150007

SUNDSTRAND PUMP ASSEMBLY

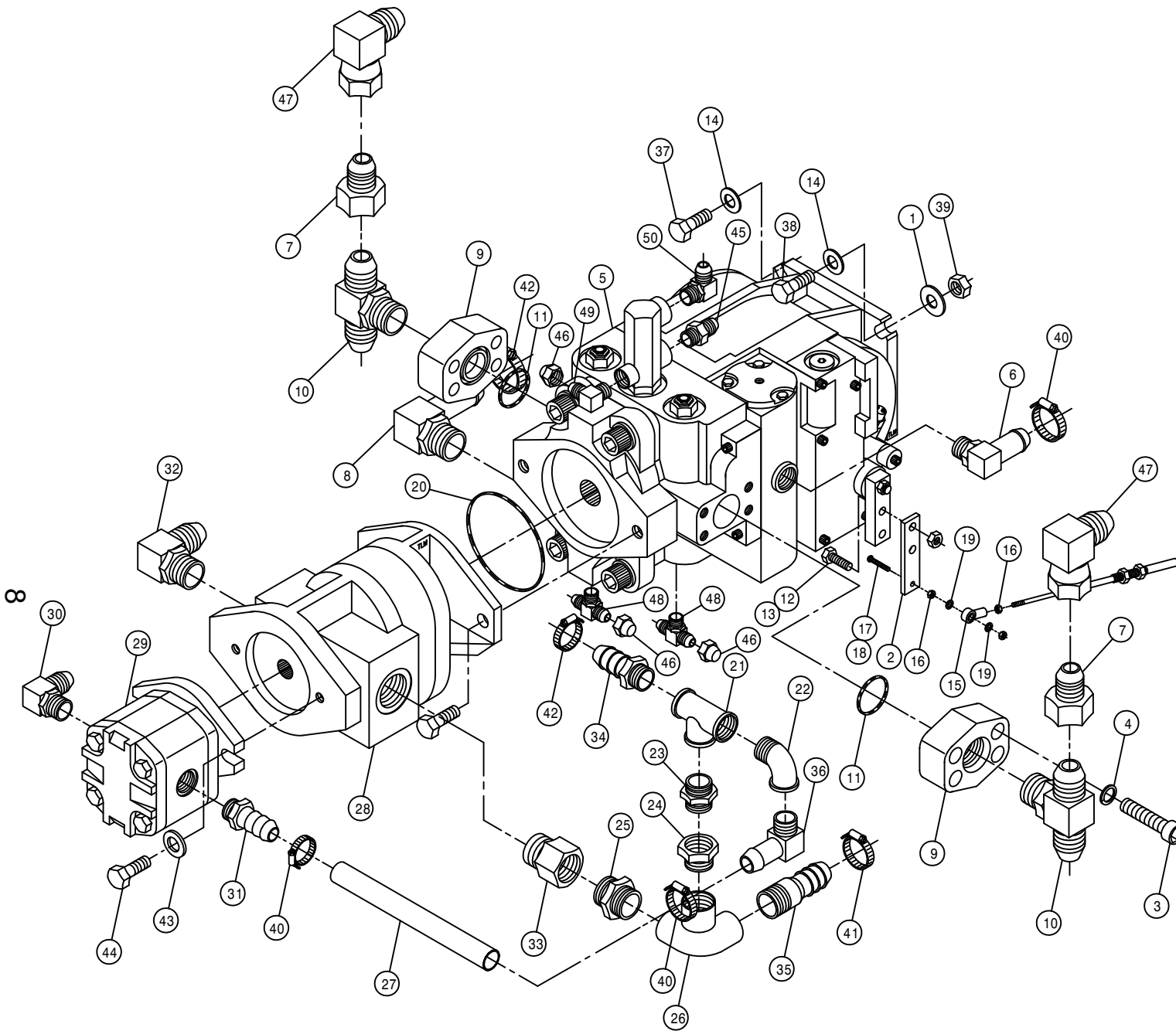

DET.	QTY	PART NO.	DESCRIPTION
1	2	483041	1/2 REGULAR FLAT WASH PLT
2	1	316160	PUMP CONT LEVER EXT 280 CUMM
3	8	470188	7/16-14 X 1 1/2 SOCHD CAP SCR
4	8	470189	7/16 HC LOCK WASH FOR 618598
5	1	606911	SUND 75CC PUMP,B-MT W/FILT
6	1	618118	3/4 HOSE BARB-90-1 1/16MOR
7	2	618541	1 5/16FJIC-1 1/16MJIC ADPTR
8	1	618564	1IN HOSE BARB-90-1 5/16MOR
9	2	618598	1 IN 4-BOLT FLG X 1 5/16FOR
10	2	618599	1 5/16MOR BRANCH TEE-1 5/16MJ
11	2	870219	BUNA ORING 1 5/16 X 1 9/16
12	2	900003	1/4UNC X 1 HEX BOLT
13	2	914000	1/4UNC HEX STOVER NUT
14	4	920004	1/2 FLAT WASHER SAE
15	1	473921	BALL JOINT NO 10-32 THD
16	2	910027	#10-32 HEX NUT
17	1	903893	10 32 X 1 SLT RD HD MACH SCR
18	1	914027	#10-32 HEX STOVER NUT
19	2	920510	LOCK WASH NO 10
20	1	606870	O-RING FOR 606865 SUND B-MT
21	1	505101	BLK PIPE TEE 1.00NPT
22	1	505200	BLK PIPE ST EL 90DEG 1.00NPT
23	1	505105	1MNPT HEX PIPE NIPPLE STL
24	1	506005	1 1/4 TO 1 RED BUSH BLK MAL
25	1	507026	1 1/4MNPT HEX PIPE NIPPLE STL
26	1	506701	SIDE OUTLET EL 90DEG 1.25NPT
27	1	601311	HOSE, 3/4 X 8 2BR RED
28	1	606894	SUND GEAR PUMP 3.40CI SPLINED
29	1	606891	SUND GEAR PMP .52CI SPLINED
30	1	611128	7/8MJIC-90-7/8MOR LBO
31	1	618075	3/4 HOSE BARB-1 1/16MOR
32	1	618178	1 5/16MJIC-90-1 5/16MOR LBO
33	1	618596	1 5/8MOR-1 1/4FNPT ADPTR
34	1	714560	1NPT X 1 HOSE BARB
35	1	715660	HOSE BARB 1 1/4NPT X 1 1/4
36	1	716000	3/4 HOSE BARB-90-1MNPT
37	2	900266	1/2UNC X 1 3/4 HEX BOLT
38	2	900267	1/2UNC X 2 HEX BOLT
39	2	914008	1/2UNC HEX STOVER NUT
40	3	520055	HOSE CLAMP NO 12 PLATED
41	1	520085	HOSE CLAMP NO 24 PLATED
42	2	520087	HOSE CLAMP NO 20 PLATED
43	2	920002	WASH FLAT 3/8 SAE
44	2	900130	3/8UNC X 1 1/4 HEX BOLT
45	1	618327	3/4MJIC-7/8MOR ADPTR
46	3	618531	9/16FJIC CAP NUT
47	2	618191	1 1/16MJ-90-1 1/16FJ SWIV LBO
48	2	618629	9/16MOR BRANCH TEE-9/16MJIC
49	1	618119	9/16MJIC-90-9/16MOR LBO
50	1	618183	3/4MJIC-90-7/8MOR LBO

NOTE: 1. ASSEMBLY SHOWN IS FOR GAS OPTION EXCEPT FOR DETAIL 47 WHICH IS FOR DIESEL OPTION.
 2. FOR DIESEL OPTION REPLACE ITEMS 1, 14,37,38, AND 39 WITH (4) 900265 - 1/2 UNC X 1 1/2 HEX BOLT AND (4) 920004 - 1/2 SAE FLAT WASHER.

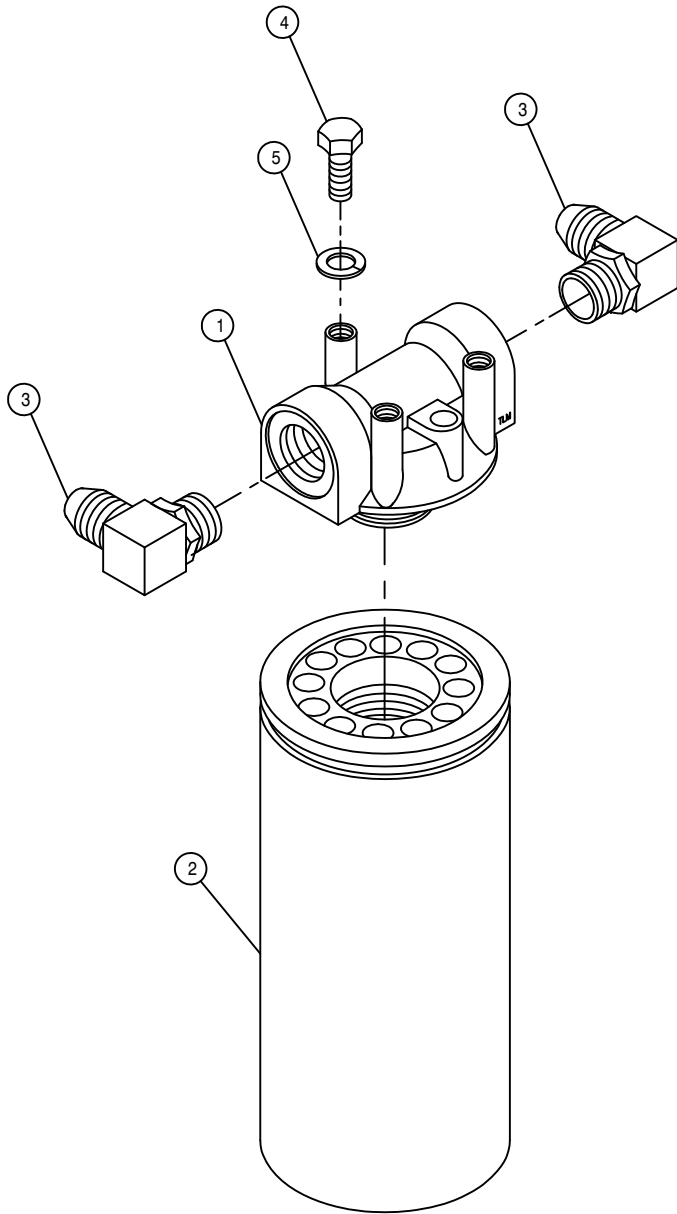

HI-PRESS FILTER ASSEMBLY

DET.	QTY	PART NO.	DESCRIPTION
1	1	605606	FILTER HEAD, ZINZA HI-PRESS
2	1	605607	FILTER, 10 MICRON ZINGA, HIPRES
3	2	618474	3/4MJIC-90-1 1/16MOR LBO
4	3	900064	5/16UNC X 3/4 HEX BOLT
5	3	920501	LOCK WASH 5/16

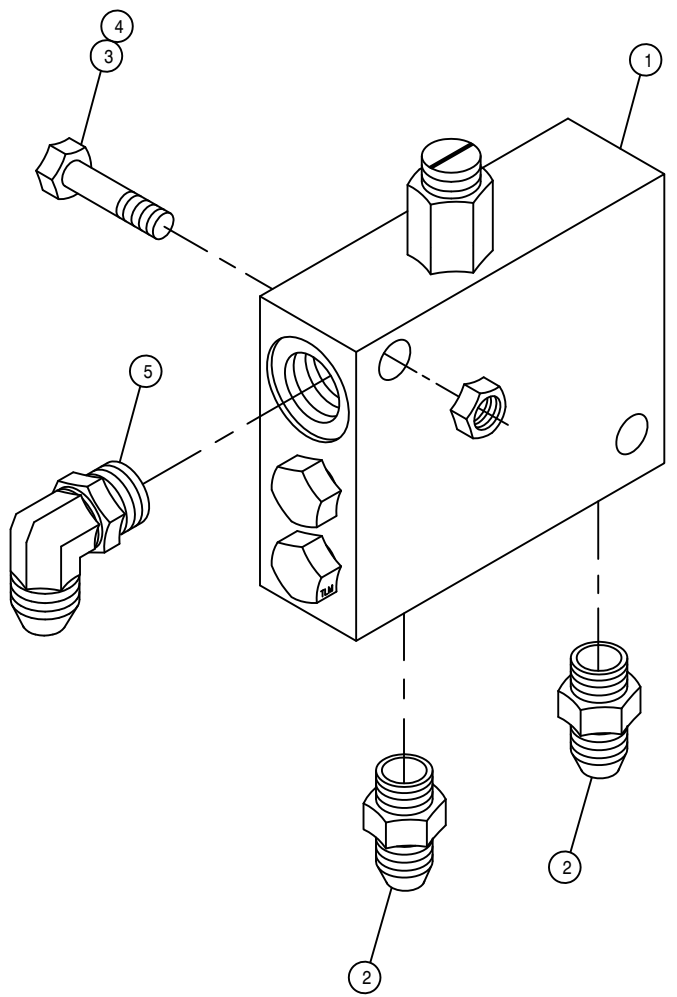

LOOP FLUSHING VALVE ASSEMBLY

DET.	QTY	PART NO.	DESCRIPTION
	1	610580	REMOTE FLUSHING VALVE, SUND
	2	618126	9/16MJC-9/16MOR ADPTR
	3	900133	3/8UNC X 2 HEX BOLT
	4	914004	3/8UNC HEX STOVER NUT
	5	618119	9/16MJC-90-9/16MOR LBO

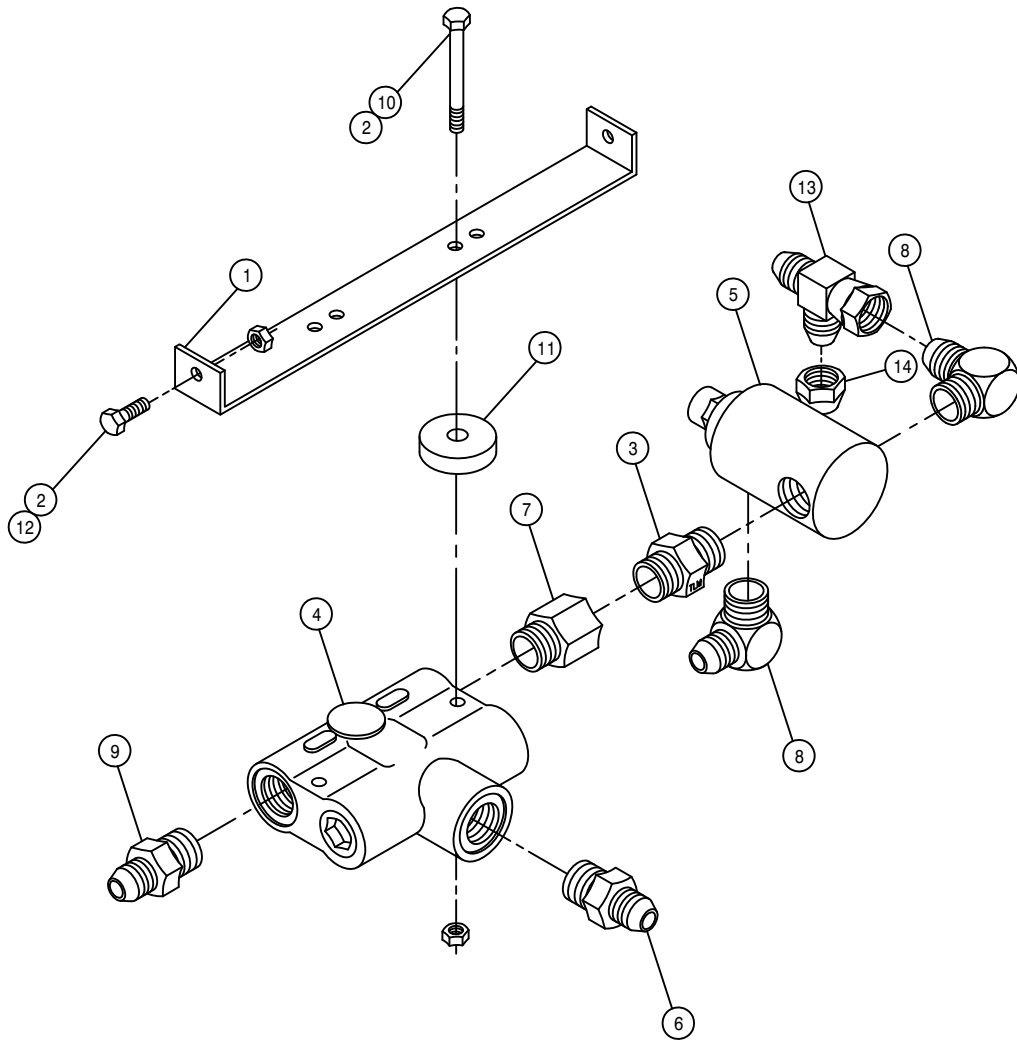

FLOW DIVIDER ASSEMBLY

DET. QTY PART NO. DESCRIPTION

1	1	341774	FLOW DIVIDER MT 280	89
2	4	914000	1/4UNC HEX STOVER NUT	
3	1	500000	1/2MNPT HEX PIPE NIPPLE STL	
4	1	607504	FLO DIV B50 2-8GPM 7/8 FOR	
5	1	607512	RELIEF VALVE, RL50, 1850 PSI	
6	1	611126	7/8MJIC-7/8MOR ADPTR	
7	1	618072	7/8MOR-1/2FNPT ADPTR	
8	2	618107	9/16MJIC-90-1/2MNPT LBO	
9	1	618310	9/16MJIC-7/8MOR ADPTR	
10	2	900008	1/4UNC X 2 1/2 HEX BOLT	
11	2	748500	RUBER WASH 3/8X1/4IDX1 1/2 OD	
12	2	900002	1/4UNC X 3/4 HEX BOLT	
13	1	618486	9/16FJIC SW RUN TEE-9/16MJIC	
14	1	618531	9/16FJIC CAP NUT	

POSITRACTION VALVE ASSEMBLY

DET. QTY PART NO. DESCRIPTION

1	1	341849	POSITRACTION VALVE MT	200
2	1	341850	200 RETURN TEE MT WLD	89
3	2	505213	RED BUSH 1 X 3/4 BLK MAL	
4	1	610586	POSITRACTION VLV	94
5	1	614660	1IN STL TEE WLD 280	89
6	2	618156	7/8MJIC-90-3/4MNPT LBO	
7	2	618601	7/8MJIC-1 5/16MOR ADPT	
8	1	618186	1 5/16MJIC-1 5/16MOR ADPTR	
9	1	618322	1 5/16MJIC-1MNPT ADPTR	
10	2	900012	1/4UNC X 3 1/2 HEX BOLT	
11	2	900002	1/4UNC X 3/4 HEX BOLT	
12	5	914000	1/4UNC HEX STOVER NUT	
13	1	900003	1/4UNC X 1 HEX BOLT	
14	2	920000	1/4 FLAT WASH SAE	

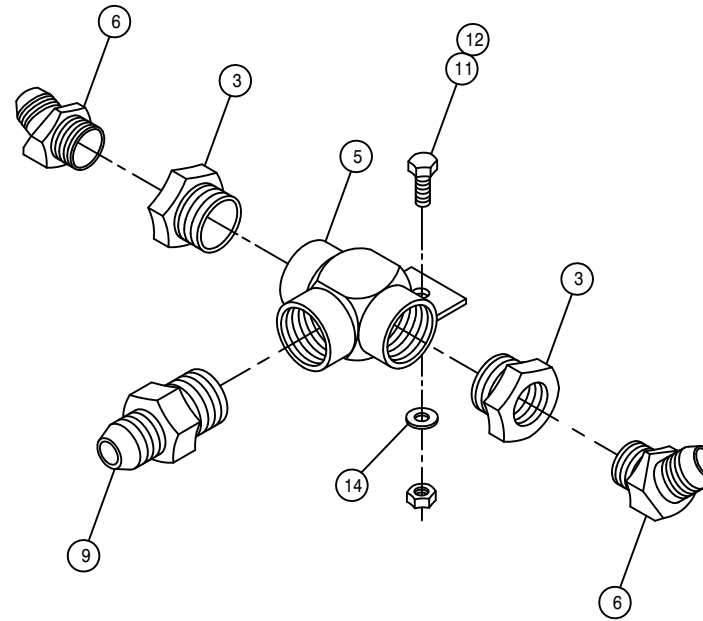
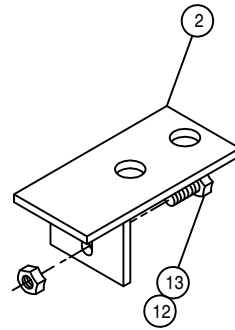
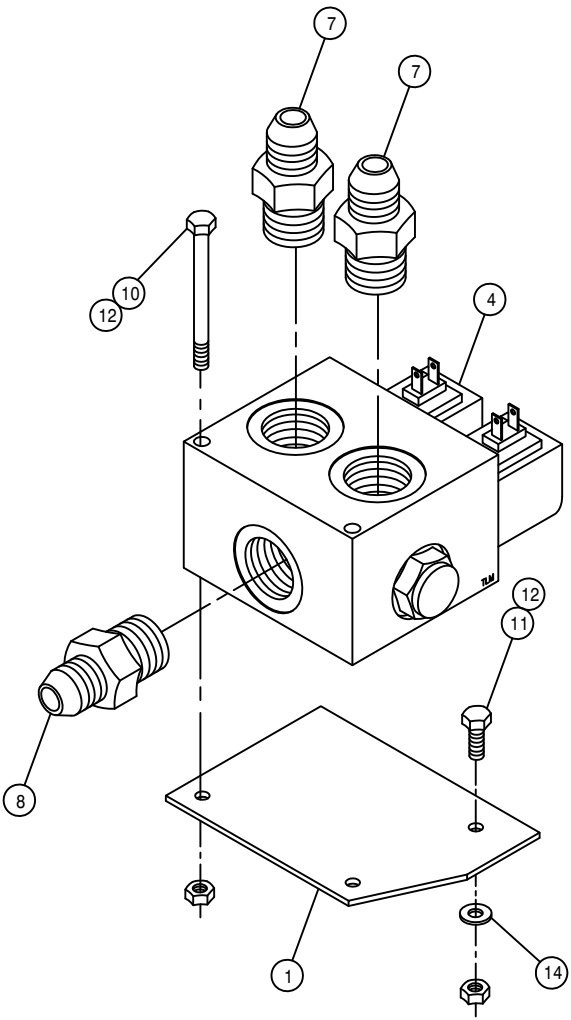

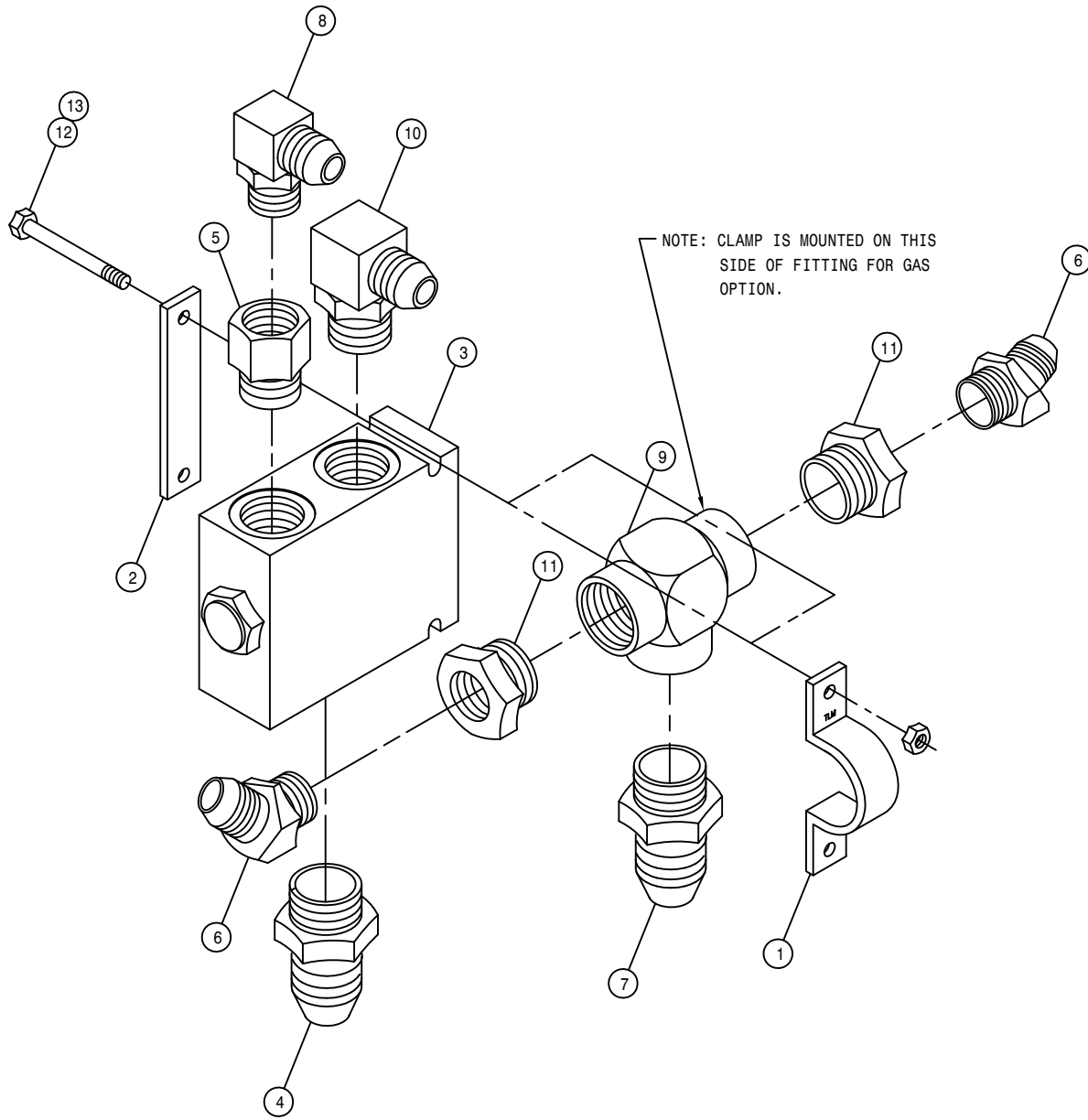

POSITRACTION VALVE ASSEMBLY

DET. QTY PART NO. DESCRIPTION

1	1	314842	TEE CLAMP, TRAC VLV 200	89
2	1	314843	TEE KEEPER, TRAC VLV 200	89
3	1	610468	POSITRACTION VLV MOD CONT 20G	
4	1	618308	1 1/16MJIC-1 5/16MOR ADPTR	
5	1	618312	1 5/16MOR-1 1/16FOR ADPTR	
6	2	618323	7/8MJIC-45-1/2MNPT LBO	
7	1	618434	1 1/16MJIC-1MNPT ADPTR	
8	1	618535	7/8MJIC-90-1 1/16MOR LBO	
9	1	618575	1FNPT PIPE TEE STL	
10	1	618589	7/8MJIC-90-1 5/16MOR LBO	
11	2	505005	RED BUSH 1 TO 1/2	
12	2	900010	1/4UNC X 3 HEX BOLT	
13	2	914000	1/4UNC HEX STOVER NUT	

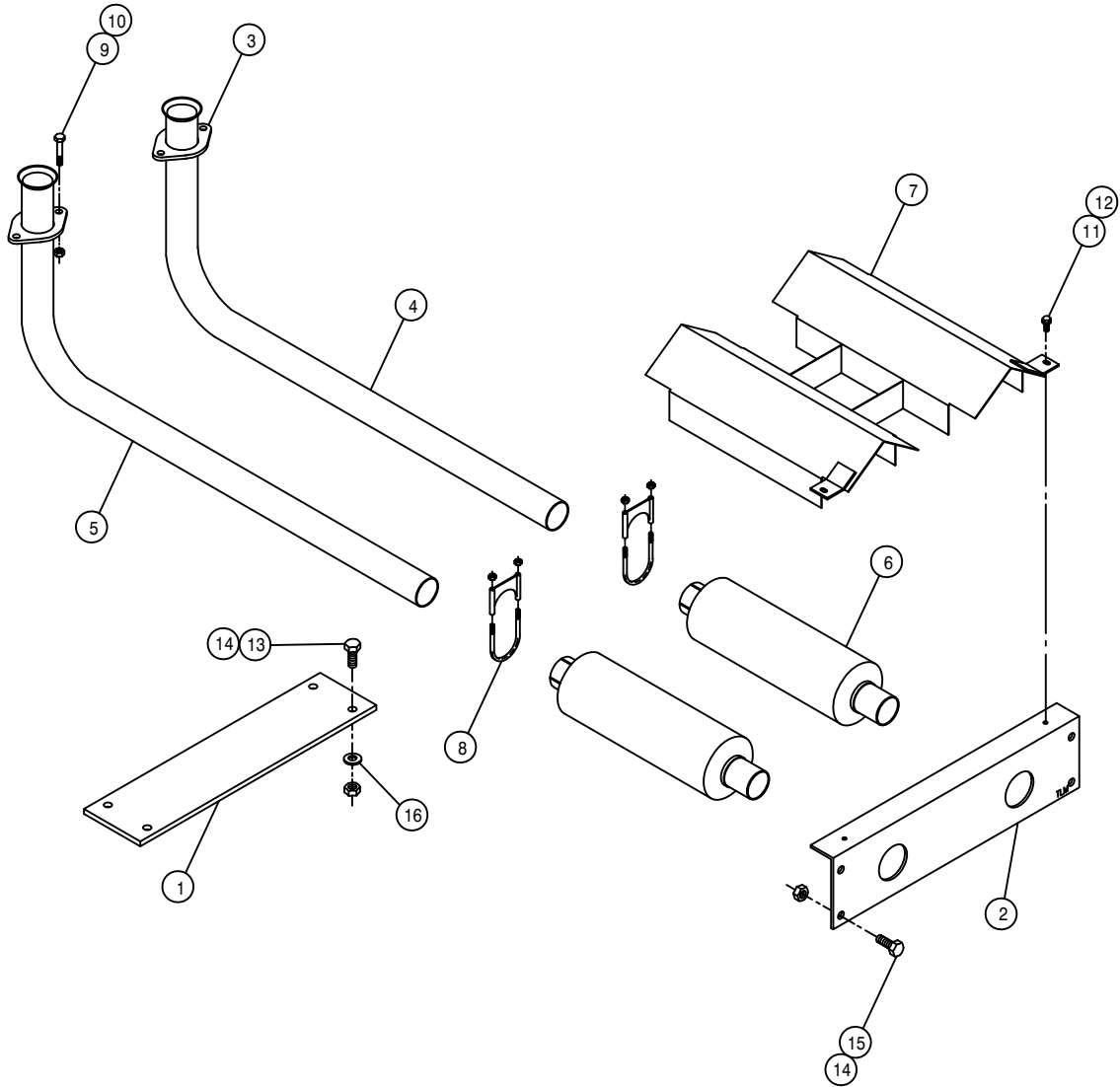

CHRY EXHAUST PIPE ASSEMBLY

DET. QTY PART NO. DESCRIPTION

1	1	361347	MAINFRAME TIE PLATE 200 318
2	1	361346	MAINFRAME REAR TIE ANGLE 280
3	2	314735	EXHAUST PIPE FLG 8240 318 82
4	1	314873	RH EXHAUST PIPE 200 CHRY 91
5	1	314874	LH EXHAUST PIPE 200 CHRY 91
6	2	319287	MUFFLER CHRY 440
7	1	341829	MUFFLER HEAT SHIELD WLD200 89
8	2	319327	MUFFLER CLAMP 2IN HVY DUTY
9	4	900170	3/8UNC X 2 1/4 HEX BOLT
10	4	914004	3/8UNC HEX STOVER NUT
11	3	470118	1/4UNC X 3/4 FLANGE HEX BOLT
12	3	470121	1/4UNC HEX FLANGE LOCK NUT
13	4	900265	1/2UNC X 1 1/2 HEX BOLT
14	8	914008	1/2UNC HEX STOVER NUT
15	4	900263	1/2UNC X 1" HEX BOLT
16	4	920004	1/2 SAE FLAT WASHER

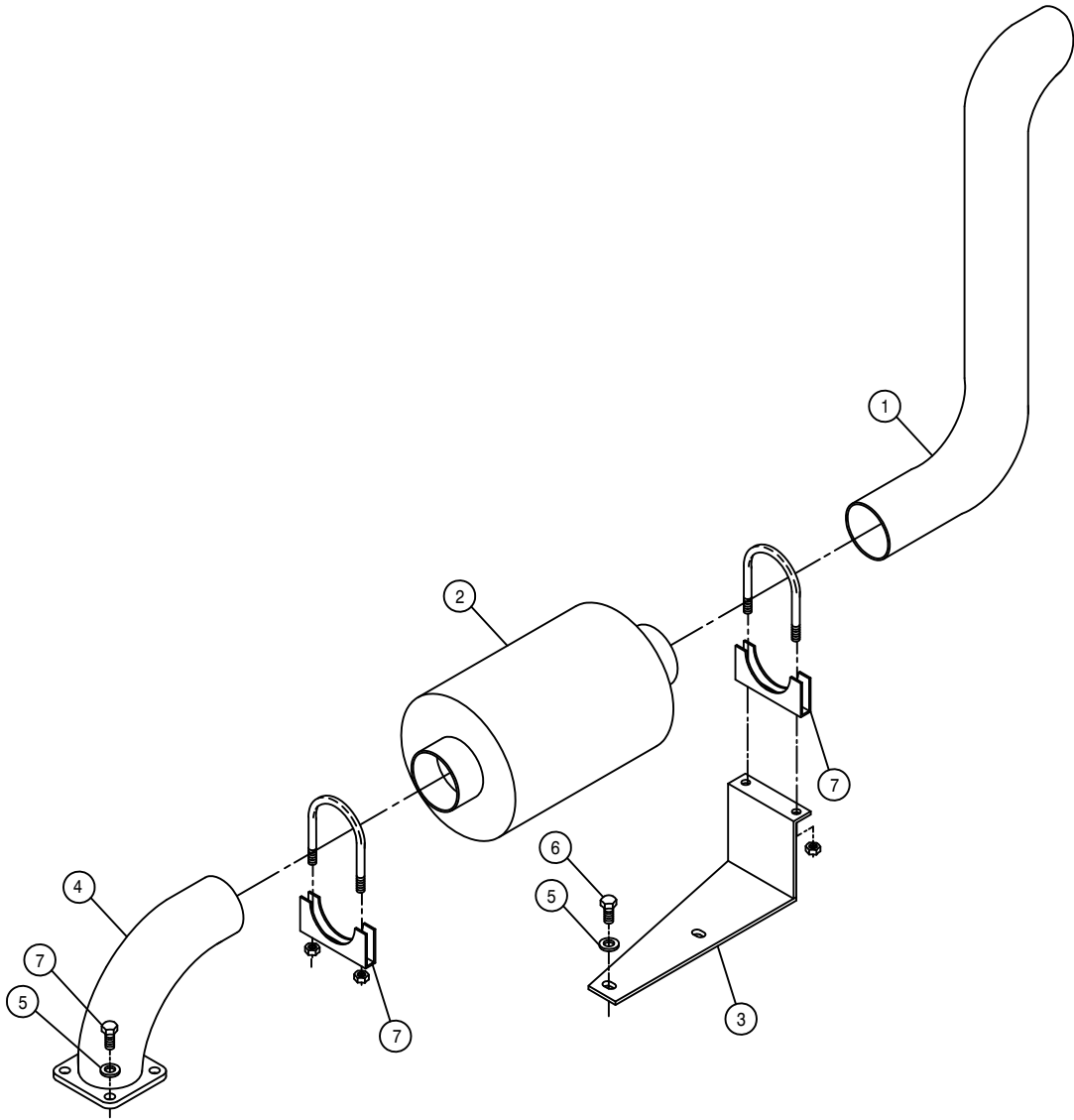

CUMMINS EXHAUST PIPE ASSEMBLY

DET. QTY PART NO. DESCRIPTION

1	1	316266	3" EXHAUST STACK	95
2	1	316267	MUFFLER, 3"	
3	1	316268	MUFFLER SUPPORT WLD,CUMM 6 95	
4	1	316262	3"-90 DEG EXH PIPE WLD	95
5	6	473798	10MM LOCK WASHER	
6	6	473797	10MM-1.50 X 25MM HEX BOLT	
7	2	470160	MUFFLER CLAMP 3.00 IN	

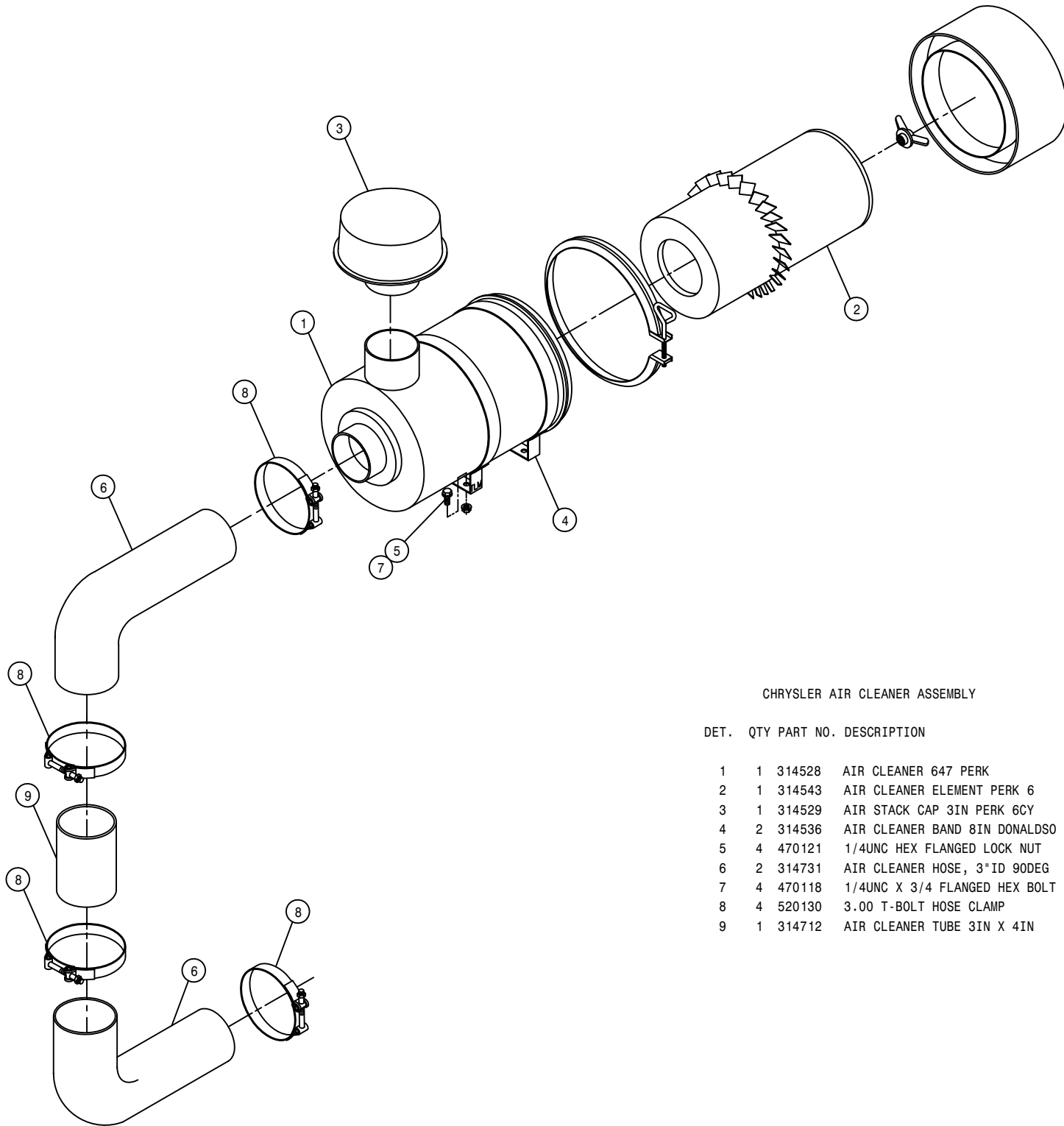

CHRYSLER AIR CLEANER ASSEMBLY

DET. QTY PART NO. DESCRIPTION

1	1	314528	AIR CLEANER 647 PERK
2	1	314543	AIR CLEANER ELEMENT PERK 6
3	1	314529	AIR STACK CAP 3IN PERK 6CY
4	2	314536	AIR CLEANER BAND 8IN DONALDSO
5	4	470121	1/4UNC HEX FLANGED LOCK NUT
6	2	314731	AIR CLEANER HOSE, 3"ID 90DEG
7	4	470118	1/4UNC X 3/4 FLANGED HEX BOLT
8	4	520130	3.00 T-BOLT HOSE CLAMP
9	1	314712	AIR CLEANER TUBE 3IN X 4IN

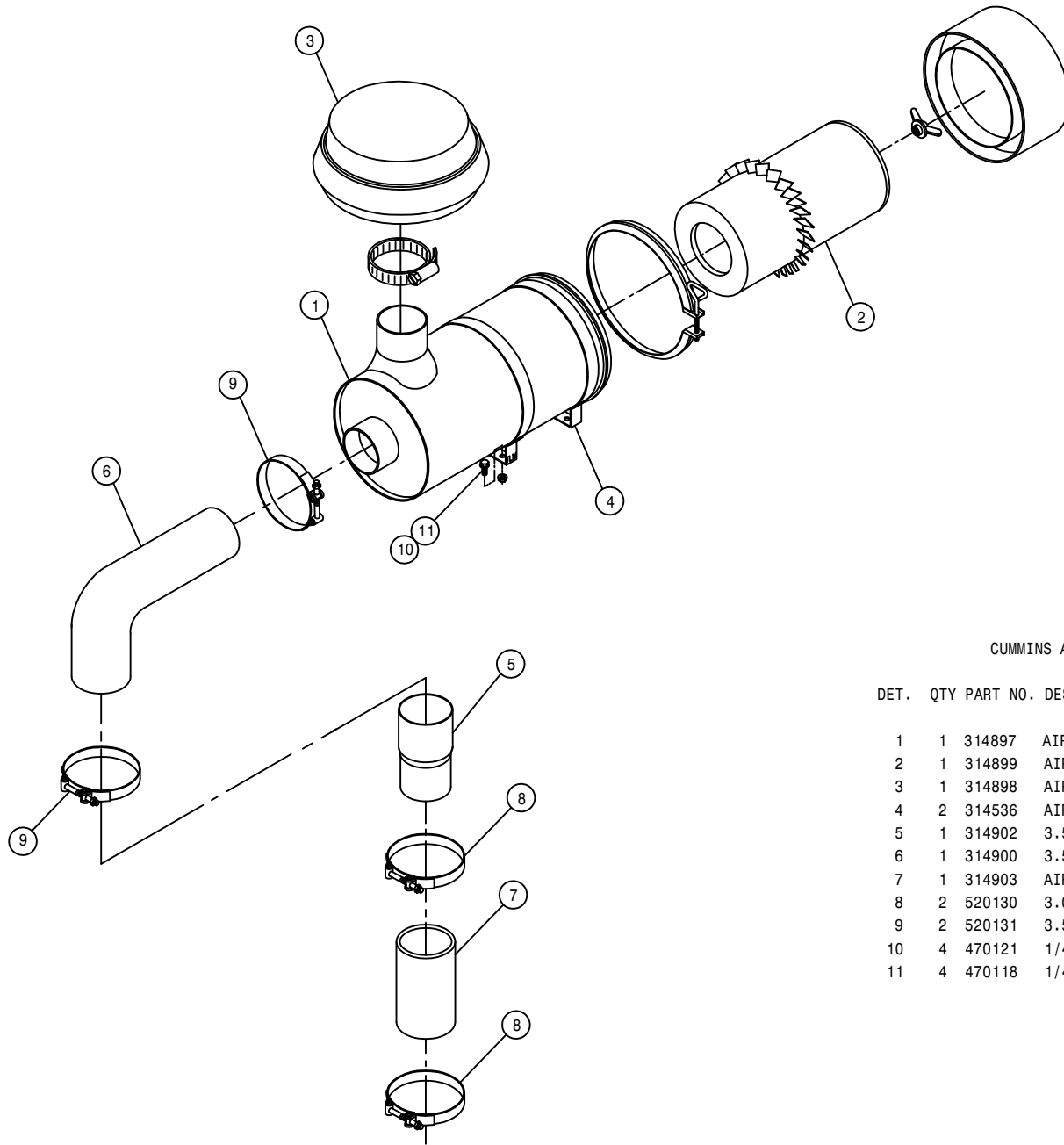

CUMMINS AIR CLEANER

DET. QTY PART NO. DESCRIPTION

1	1	314897	AIR CLEANER, 280 CFM
2	1	314899	AIR CLEANER ELEMENT FOR314897
3	1	314898	AIR CLEANER HOOD FOR 314897
4	2	314536	AIR CLEANER BAND 8IN DONALDSON
5	1	314902	3.50 - 3.00 X 6.00LG PIPE
6	1	314900	3.50 90 DEG AIR INTAKE HOSE
7	1	314903	AIR CLEANER HOSE 3ID X 6.50LG
8	2	520130	3.00 T-BOLT HOSE CLAMP
9	2	520131	3.50 T-BOLT HOSE CLAMP
10	4	470121	1/4UNC HEX FLANGED LOCK NUT
11	4	470118	1/4UNC X 3/4 FLANGED HEX BOLT

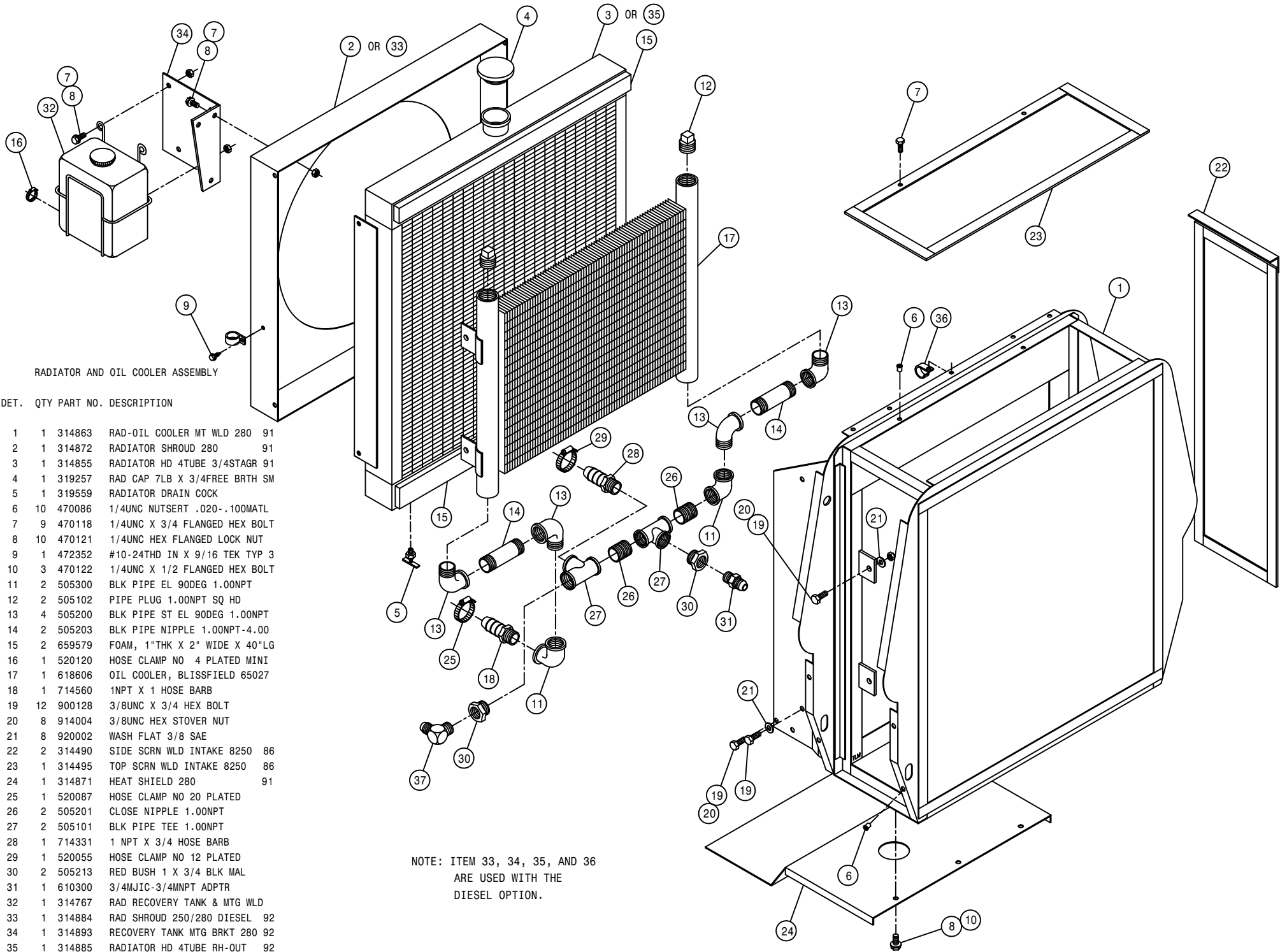

RADIATOR AND OIL COOLER ASSEMBLY

DET. QTY PART NO. DESCRIPTION

1	1	314863	RAD-OIL COOLER MT WLD 280	91
2	1	314872	RADIATOR SHROUD 280	91
3	1	314855	RADIATOR HD 4TUBE 3/4STAGR	91
4	1	319257	RAD CAP 7LB X 3/4FREE BRTH SM	
5	1	319559	RADIATOR DRAIN COCK	
6	10	470086	1/4UNC NUTSERT .020-.100MATL	
7	9	470118	1/4UNC X 3/4 FLANGED HEX BOL	
8	10	470121	1/4UNC HEX FLANGED LOCK NUT	
9	1	472352	#10-24THD IN X 9/16 TEK TYP 3	
10	3	470122	1/4UNC X 1/2 FLANGED HEX BOL	
11	2	505300	BLK PIPE EL 90DEG 1.00NPT	
12	2	505102	PIPE PLUG 1.00NPT SQ HD	
13	4	505200	BLK PIPE ST EL 90DEG 1.00NPT	
14	2	505203	BLK PIPE NIPPLE 1.00NPT-4.00	
15	2	659579	FOAM, 1"THK X 2" WIDE X 40"LG	
16	1	520120	HOSE CLAMP NO 4 PLATED MINI	
17	1	618606	OIL COOLER, BLISSFIELD 65027	
18	1	714560	1NPT X 1 HOSE BARB	
19	12	900128	3/8UNC X 3/4 HEX BOLT	
20	8	914004	3/8UNC HEX STOVER NUT	
21	8	920002	WASH FLAT 3/8 SAE	
22	2	314490	SIDE SCR N WLD INTAKE 8250	86
23	1	314495	TOP SCR N WLD INTAKE 8250	86
24	1	314871	HEAT SHIELD 280	91
25	1	520087	HOSE CLAMP NO 20 PLATED	
26	2	505201	CLOSE NIPPLE 1.00NPT	
27	2	505101	BLK PIPE TEE 1.00NPT	
28	1	714331	1 NPT X 3/4 HOSE BARB	
29	1	520055	HOSE CLAMP NO 12 PLATED	
30	2	505213	RED BUSH 1 X 3/4 BLK MAL	
31	1	610300	3/4MJIC-3/4MNPT ADPTR	
32	1	314767	RAD RECOVERY TANK & MTG WLD	
33	1	314884	RAD SHROUD 250/280 DIESEL	92
34	1	314893	RECOVERY TANK MTG BRKT 280	92
35	1	314885	RADIATOR HD 4TUBE RH-OUT	92
36	1	520128	CUSH HOSE CLAMP 9/16D X 3/4W	
37	1	610305	3/4MJIC-90-3/4MNPT LBO	

NOTE: ITEM 33, 34, 35, AND 36
ARE USED WITH THE
DIESEL OPTION.

FRONT LEG CYLINDER ASSEMBLY

DET. QTY PART NO. DESCRIPTION

1	1	472297	3/4 UNF STOVER THIN HEX NUT
2	1	620321	VEE PACK 1 1/2 X 2
3	1	620571	TUBE WLD
4	1	620573	SHAFT 1 1/4 X 17 3/8
5	1	620574	BRG HEAD 2 X 1 1/4
6	1	629002	WIPER 1 1/4 X 1 1/2 X 1/8
7	1	620578	PISTON 2 X 3/4 VPX
8	1	620579	RETAINER 2 X 3/4 X 1/4
9	1	870018	NEO ORING 3/4 X 7/8

NOTE: 620570 - CYLINDER ASSEMBLY
620575 - SEAL KIT

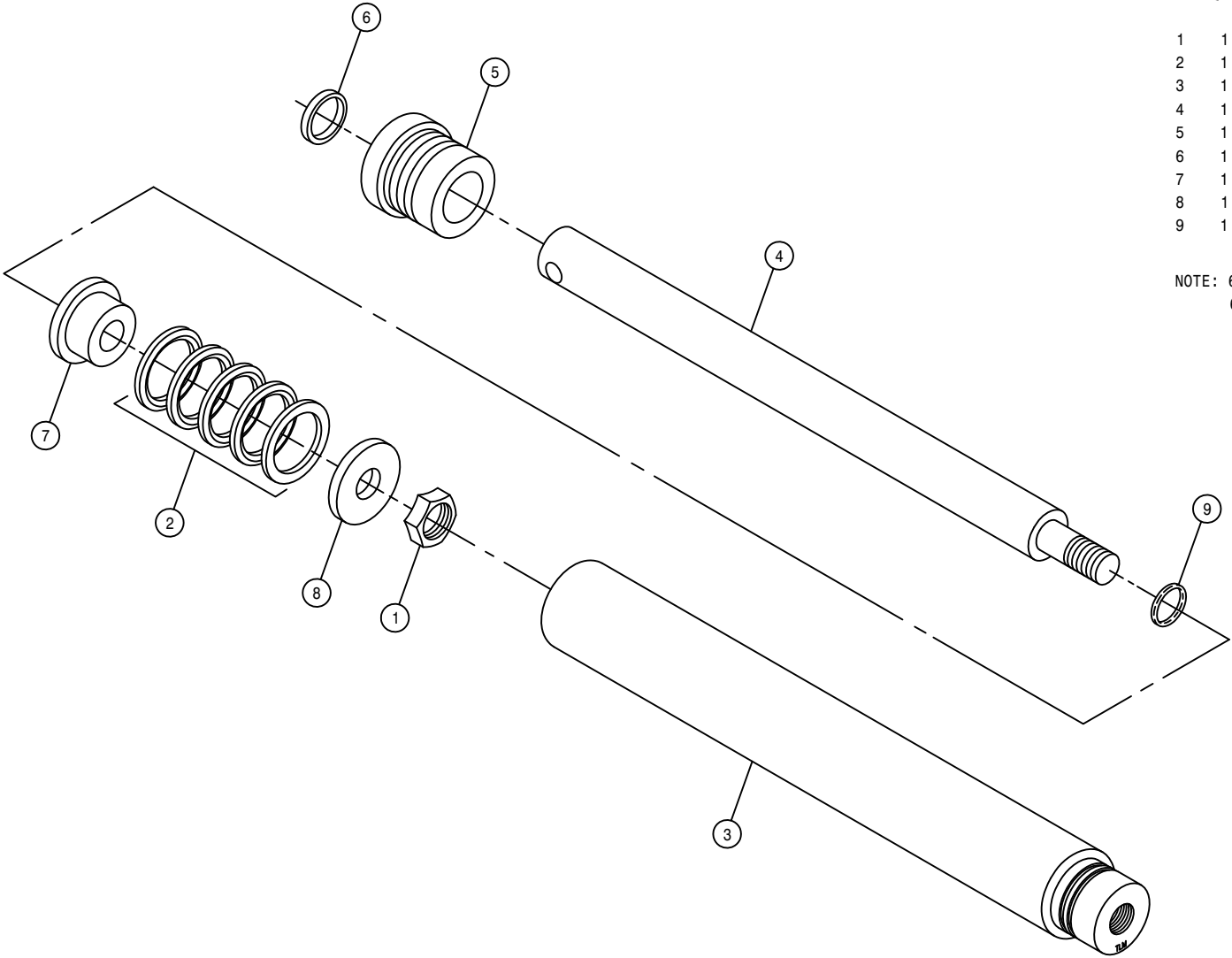

FRONT LEG ASSEMBLY

DET. QTY PART NO. DESCRIPTION

1	1	357802	RH FRT OUTER LEG WLD, 204	94
2	1	357803	LH FRT OUTER LEG WLD, 204	94
3	1	357800	RH FRT INNER LEG WLD, 204	94
4	1	357801	LH FRT INNER LEG WLD, 204	94
5	1	358562	LEG CYL MTG PLATE 280	89
6	2	358563	FRT LEG BRG KPR 280	89
7	1	358564	FRT LEG LWR NYL SLEEVE 280	89
8	1	358565	FRT LEG UPR NYL SLEEVE 280	89
9	1	358566	LEG CYL SHAFT EXTENSION280	89
10	1	358707	RH FRT LEG TUBE BRKT WLD280TA	
11	1	358708	LH FRT LEG TUBE BRKT WLD280TA	
12	2	358739	FRT LEG HYD TUBE CLMP, 284	94
13	4	900004	1/4UNC X 1 1/4 HEX BOLT	
14	4	470121	1/4UNC HEX FLANGE LOCK NUT	
15	1	470185	KEY .25 X .375 X 2.00 LG	
16	1	473903	SPIRAL PIN 1/2 X 2	640
17	1	473904	SPIRAL PIN 1/2 X 3	640
18	2	914008	1/2UNC HEX STOVER NUT	
19	3	900836	5/8UNF X 3 1/4 HEX BOLT GR8	
20	1	615659	FRT LEG INNER HYD TUBE,204	94
21	1	615660	FRT LEG CNTR HYD TUBE,204	94
22	1	615661	FRT LEG OUTER HYD TUBE,204	94
23	1	900129	3/8UNC X 1" HEX BOLT	
24	1	749293	STRG ARM BOLT, TAPERED	
25	2	471023	GREASE ZERK 1/4-28 X 45	
26	1	358740	FRT LEG HYD TUBE KPR, 284	94
27	1	620570	HYD CYL LEG LEVEL 2.00 X 12	
28	1	629515	SNAP RING 1 3/4 EXTRN HDUTY	
29	1	749290	RH STRG ARM WLD,280 TREAD ADJ	
30	1	749291	LH STRG ARM WLD,280 TREAD ADJ	
31	1	914004	3/8UNC HEX STOVER NUT	
32	3	900837	5/8UNC X 3 1/2 HEX BOLT GR8	
33	12	914811	5/8UNF HEX NUT GR8	
34	4	900000	1/4UNC X 1/2 HEX BOLT	
35	1	615614	FRT LEG CYL JUMPER HOSE280	89
36	1	358759	LEG MT V-PLT WLD, 284T	94
37	4	920500	1/4 LOCK WASHER	
38	1	914010	5/8UNC HEX STOVER NUT	
39	2	900265	1/2UNC X 1 1/2 HEX BOLT	
40	1	920505	5/8 LOCK WASHER	
41	1	471027	GREASE ZERK 1/8NPT 90DEG LP	
42	1	822040	5/8-18UNF SLOTTED HEX NUT	
43	1	470035	COTTER PIN 5/32 X 1 1/2	

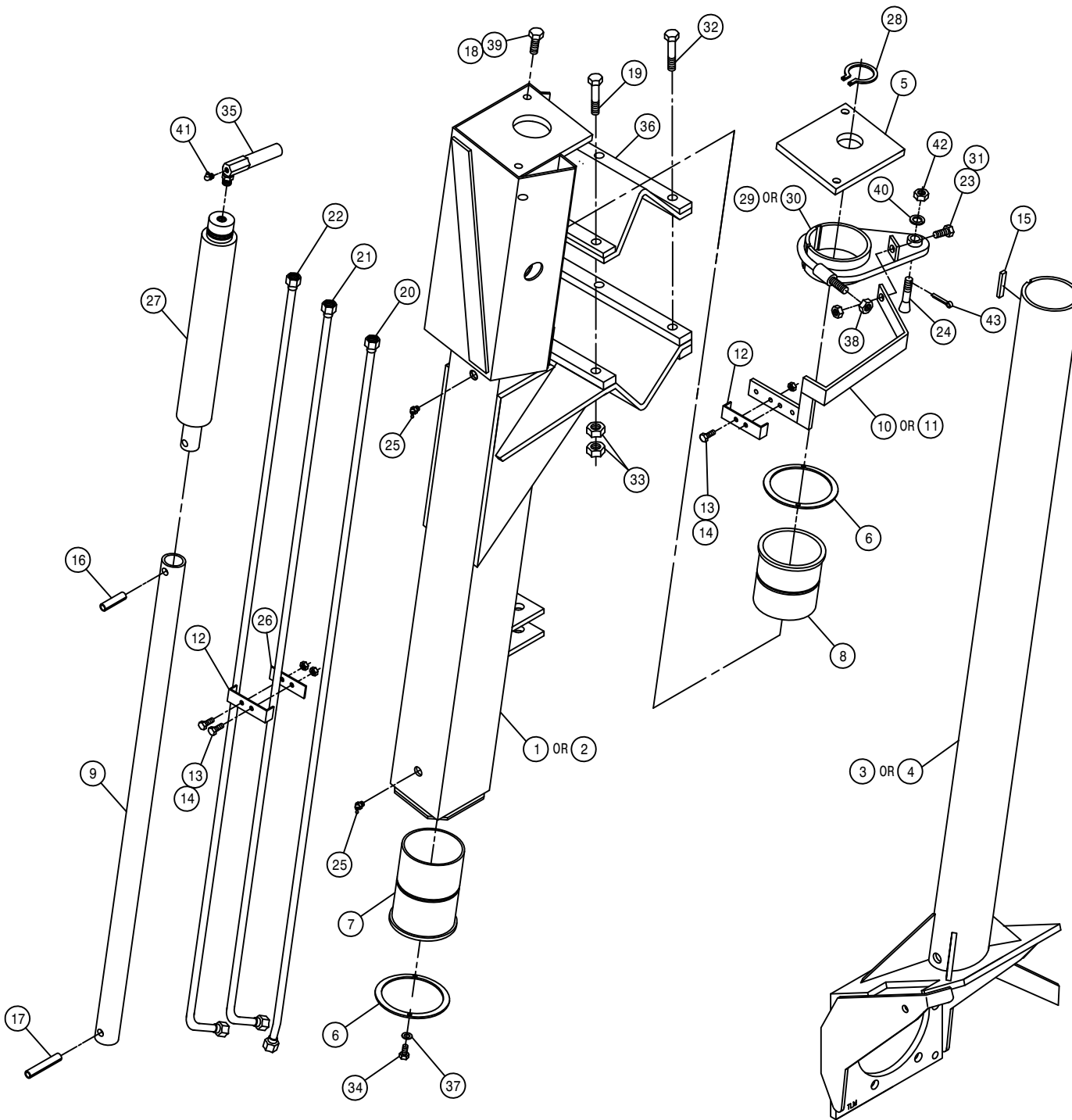

FRONT LEG BRAKE ASSEMBLY

DET. QTY PART NO. DESCRIPTION

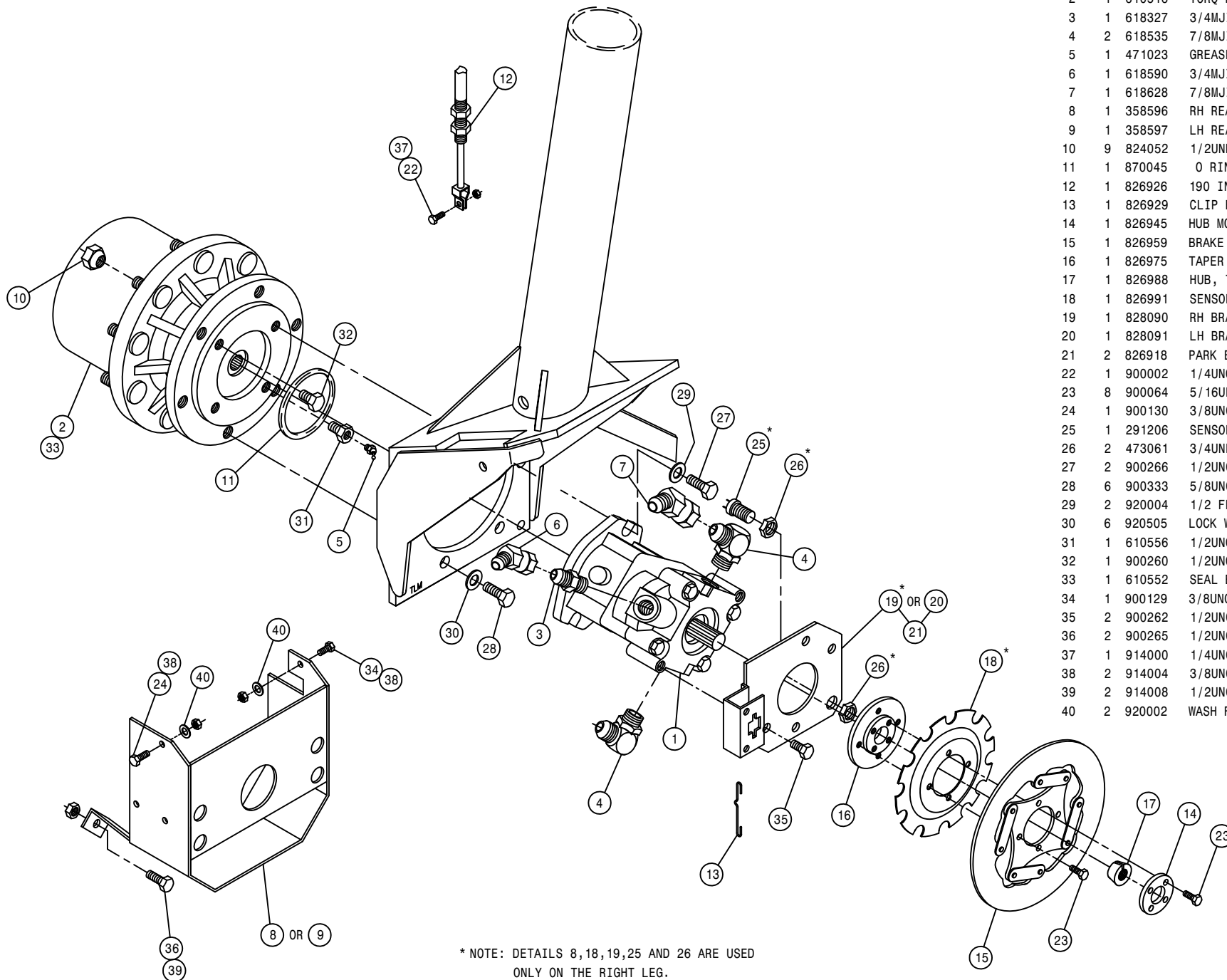

DET.	QTY	PART NO.	DESCRIPTION
1	1	610557	SUND M35-3102 WHL MTR W/SHFT
2	1	610516	TORQ HUB 24 TO 1 B-MT W1BFNZ
3	1	618327	3/4MJIC-7/8MOR ADPTR
4	2	618535	7/8MJIC-90-1 1/16MOR LBO
5	1	471023	GREASE ZERK 1/4-28 X 45
6	1	618590	3/4MJIC-45-3/4FJIC SWIV LBO
7	1	618628	7/8MJIC-45-7/8FJIC SWIV LBO
8	1	358596	RH REAR WHL MTR SHLD WLD 280
9	1	358597	LH REAR WHL MTR SHLD WLD 280
10	9	824052	1/2UNF 60 DEG WHL NUT
11	1	870045	O RING 4 1/8 OD X 4 ID
12	1	826926	190 IN BRAKE CABLE
13	1	826929	CLIP BRAKE RETAINER
14	1	826945	HUB MOUNT, BRAKE
15	1	826959	BRAKE DISC SUB ASSY
16	1	826975	TAPER LOCK HUB
17	1	826988	HUB, TAPER LOCK 13 TEETH
18	1	826991	SENSOR DISC, 11N,280 BRAKE 93
19	1	828090	RH BRAKE MT WLD, 204 94
20	1	828091	LH BRAKE MT WLD, 204 94
21	2	826918	PARK BRAKE PAD
22	1	900002	1/4UNC X 3/4 HEX BOLT
23	8	900064	5/16UNC X 3/4 HEX BOLT
24	1	900130	3/8UNC X 1 1/4 HEX BOLT
25	1	291206	SENSOR, SPEEDO/TACH W/NUT
26	2	473061	3/4UNF TRUSEAL HEX NUT
27	2	900266	1/2UNC X 1 3/4 HEX BOLT
28	6	900333	5/8UNC X 1 1/2 HEX BOLT
29	2	920004	1/2 FLAT WASHER SAE
30	6	920505	LOCK WASHER 5/8
31	1	610556	1/2UNC X 1/2 ZERK BOLT T-HUB
32	1	900260	1/2UNC X 1/2 HBOLT, GR2 UNPLT
33	1	610552	SEAL BOOT FOR W1BFNZ, W2B2FZ
34	1	900129	3/8UNC X 1 HEX BOLT
35	2	900262	1/2UNC X 3/4 HEX BOLT
36	2	900265	1/2UNC X 1 1/2 HEX BOLT
37	1	914000	1/4UNC HEX STOVER NUT
38	2	914004	3/8UNC HEX STOVER NUT
39	2	914008	1/2UNC HEX STOVER NUT
40	2	920002	WASH FLAT 3/8 SAE

* NOTE: DETAILS 8, 18, 19, 25 AND 26 ARE USED ONLY ON THE RIGHT LEG.

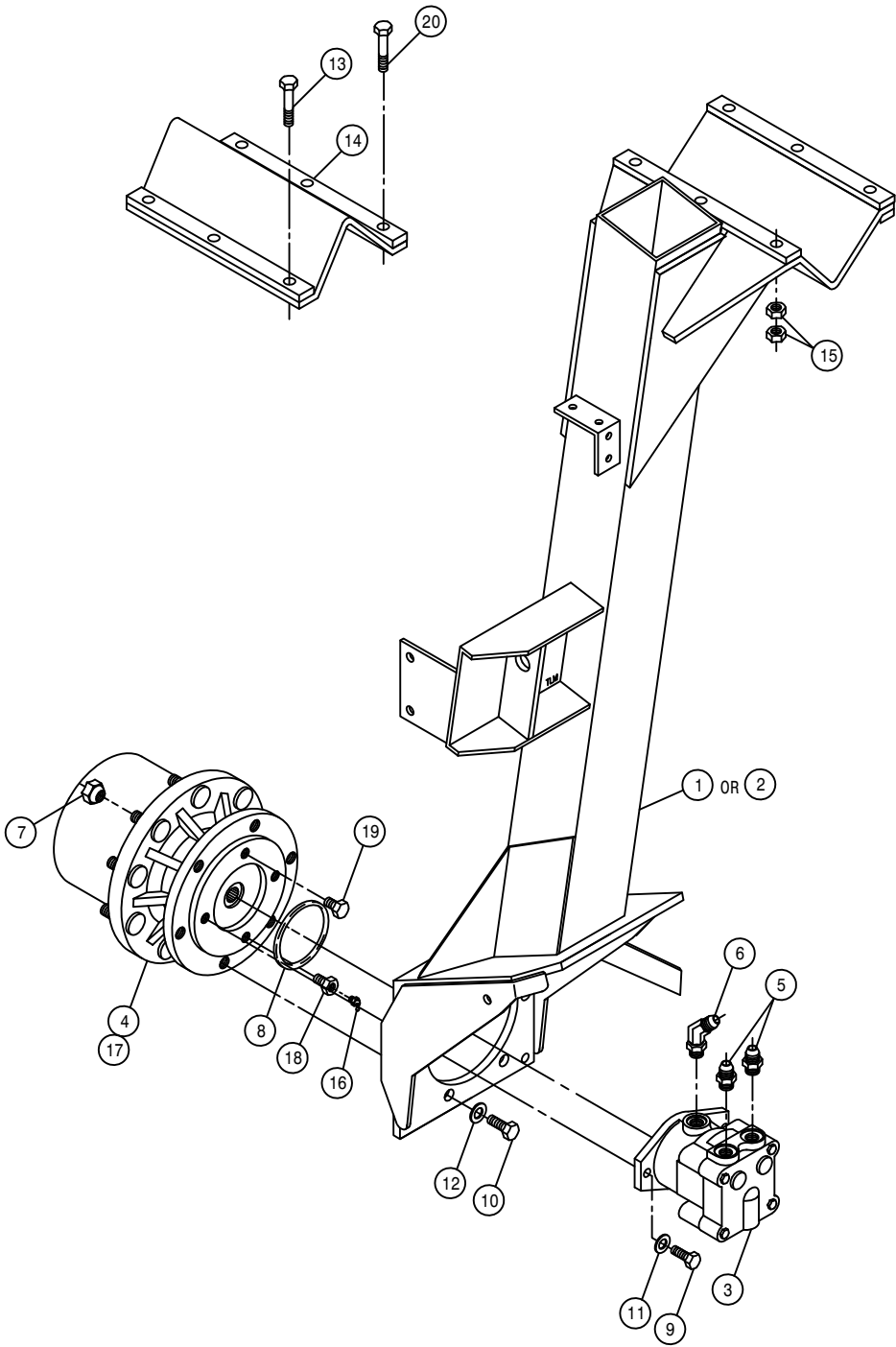

REAR LEG ASSEMBLY

DET. QTY PART NO. DESCRIPTION

1	1	357804	RH REAR LEG WLD, 204	94
2	1	357805	LH REAR LEG WLD, 204	94
3	1	610567	SUND M25-3000 WHL MTR 1.5CI	
4	1	610515	TORQ HUB 18 TO 1 B-MT W1BFNZ	
5	2	611126	7/8MJIC-7/8MOR ADPTR	
6	1	618496	9/16MJIC-45-3/4MOR LBO	
7	9	824052	1/2UNF 60 DEG WHL NUT	
8	1	870045	O RING 4 1/8 OD X 4 ID	
9	2	900266	1/2UNC X 1 3/4 HEX BOLT	
10	6	900333	5/8UNC X 1 1/2 HEX BOLT	
11	2	920004	1/2 FLAT WASHER SAE	
12	6	920505	LOCK WASHER 5/8	
13	3	900836	5/8UNF X 3 1/4 HEX BOLT GR8	
14	1	358759	LEG MT V-PLT, 284T	94
15	12	914811	5/8UNF HEX NUT GR8	
16	1	471023	GREASE ZERK 1/4-28 X 45	
17	1	610552	SEAL BOOT FOR W1BFNZ, W2B2FZ	
18	1	610556	1/2UNC X 1/2 ZERK BOLT T-HUB	
19	1	900260	1/2UNC X 1/2 HBOLT, GR2 UNPLT	
20	3	900837	5/8UNF X 3 1/2 HEX BOLT GR8	

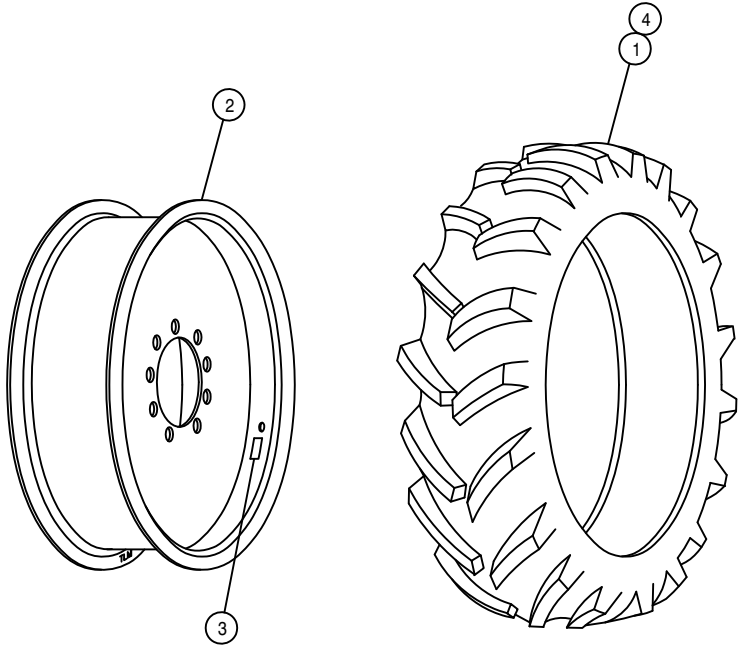

TIRE AND RIM ASSEMBLY

DET. QTY PART NO. DESCRIPTION

1	1	820042	12.4 X 28 4P TIRE,BRIDGESTONE
2	1	820020	RIM WLD, W10 X 28, W1B 200 89
3	1	650985	WHL BOLT TORQ DECAL 203854C
4	1	820002	12.4 X 28 INNER TUBE

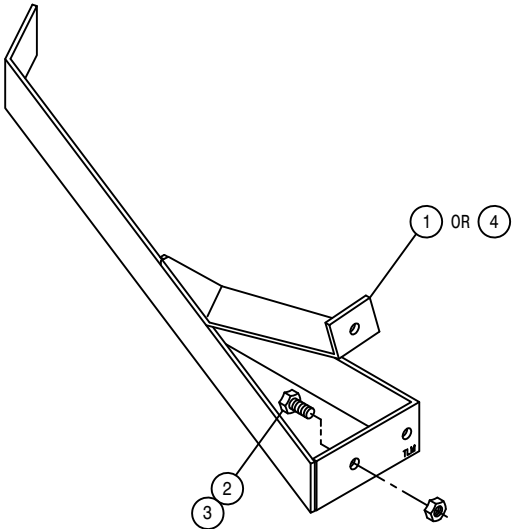

CROP GUIDES

DET.	QTY	PART NO.	DESCRIPTION
1	1	662217	RH REAR STALK GUIDE WLD280 89
2	2	900129	3/8UNC X 1 HEX BOLT
3	2	914004	3/8 UNC STOVER NUT
4	1	662218	LH REAR STALK GUIDE WLD280 89

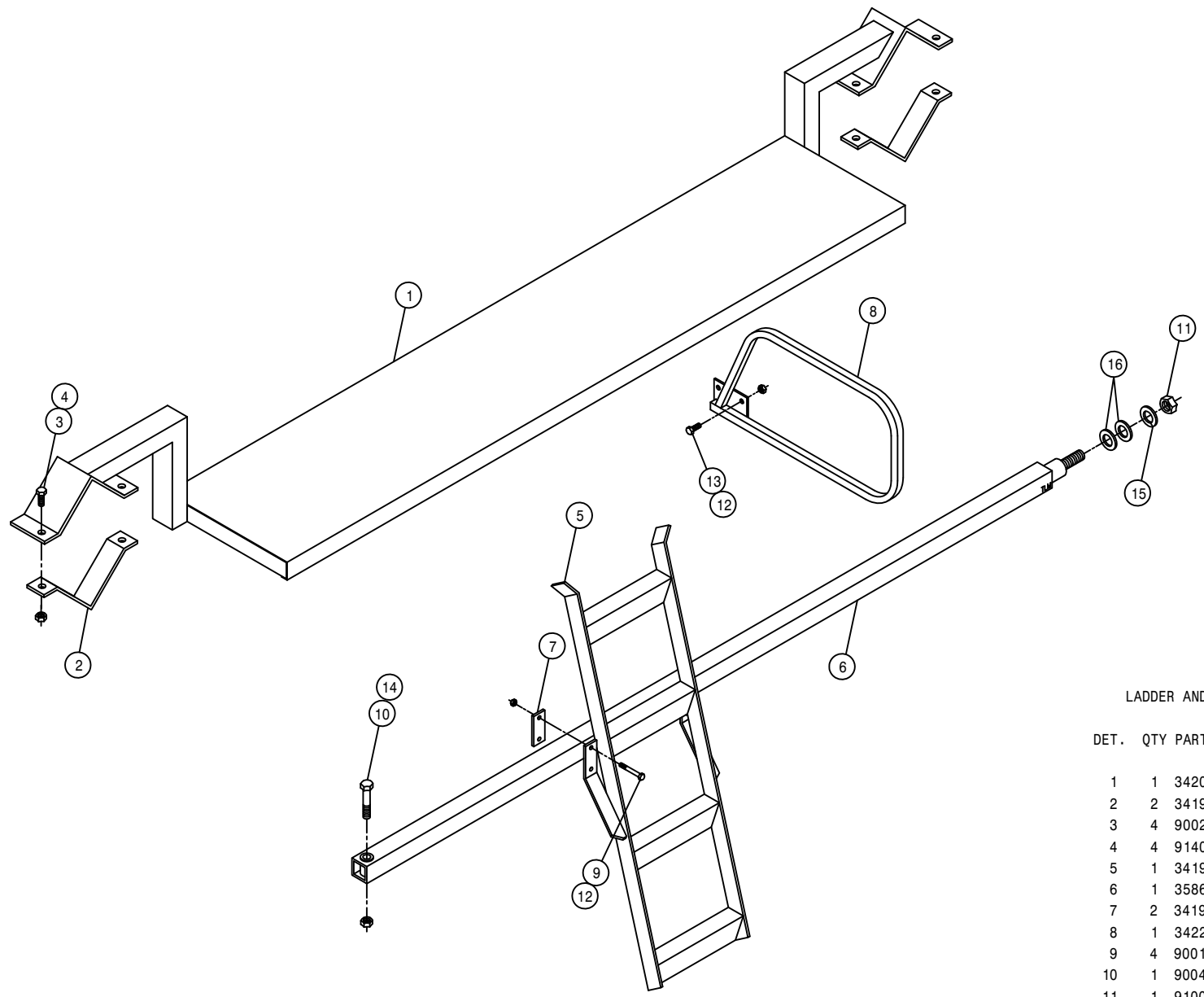

LADDER AND SERVICE PLATFORM ASSEMBLY

DET.	QTY	PART NO.	DESCRIPTION	
	1	342007	SERV PLATFORM WLD 200-280	92
	2	341900	SERVICE PLATFORM MT KPR	90
	3	900265	1/2UNC X 1 1/2 HEX BOLT	
	4	914008	1/2UNC HEX STOVER NUT	
	5	341908	200 LADDER WLD 200	90
	6	358673	LEG BRACE WLD 200	92
	7	341912	200 LADDER KEEPER	90
	8	342267	HANDRAIL WLD, 204	94
	9	900136	3/8UNC X 3 HEX BOLT	
	10	900410	3/4UNC X 4 HEX BOLT	
	11	910017	1 UNC HEX NUT	
	12	914004	3/8UNC HEX STOVER NUT	
	13	900129	3/8UNC X 1 HEX BOLT	
	14	914012	3/4UNC HEX STOVER NUT	
	15	920508	LOCK WASH 1 IN	
	16	920008	1 FLATWASHER SAE	

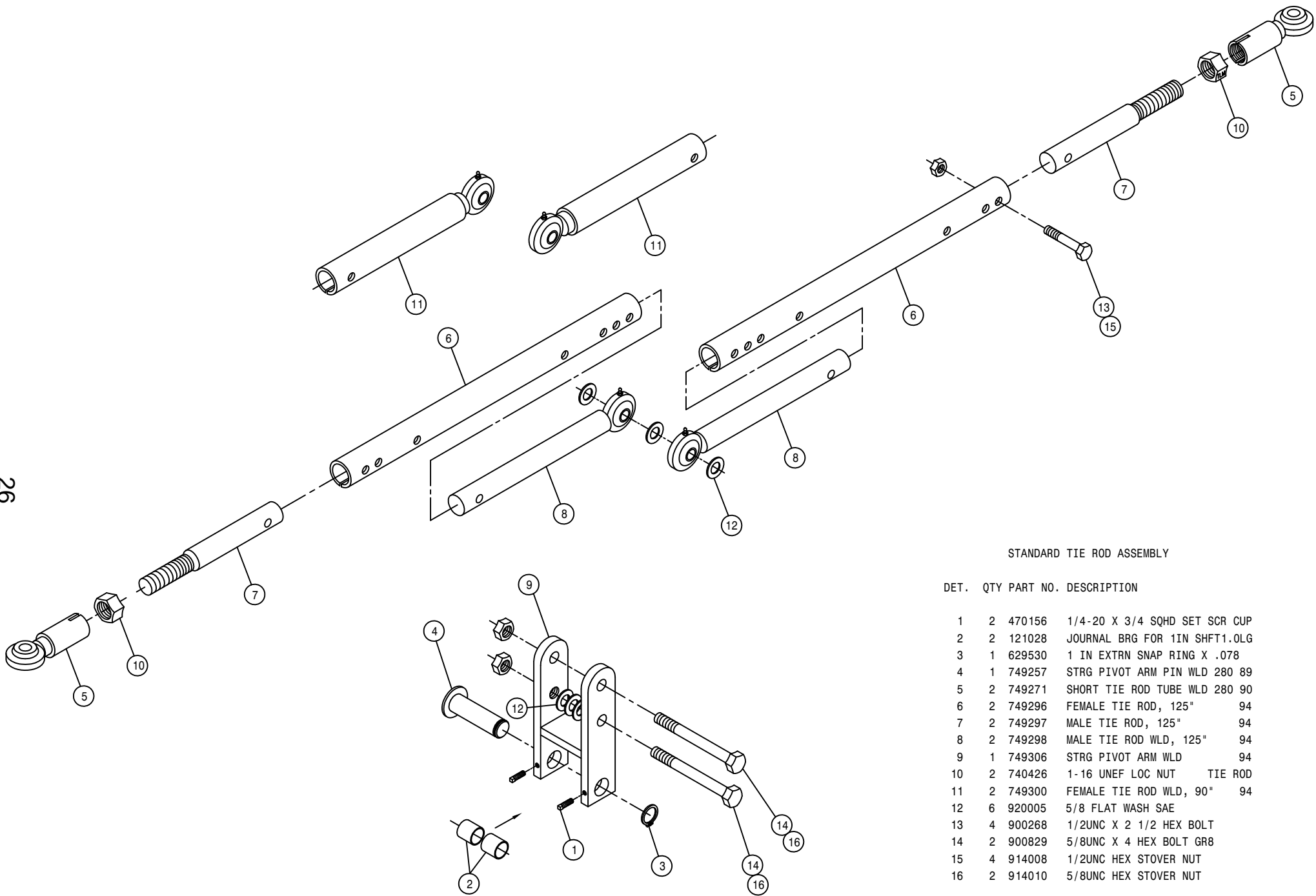

STANDARD TIE ROD ASSEMBLY

DET.	QTY	PART NO.	DESCRIPTION
1	2	470156	1/4-20 X 3/4 SQHD SET SCR CUP
2	2	121028	JOURNAL BRG FOR 1IN SHFT1.0LG
3	1	629530	1 IN EXTRN SNAP RING X .078
4	1	749257	STRG PIVOT ARM PIN WLD 280 89
5	2	749271	SHORT TIE ROD TUBE WLD 280 90
6	2	749296	FEMALE TIE ROD, 125" 94
7	2	749297	MALE TIE ROD, 125" 94
8	2	749298	MALE TIE ROD WLD, 125" 94
9	1	749306	STRG PIVOT ARM WLD 94
10	2	740426	1-16 UNEF LOC NUT TIE ROD
11	2	749300	FEMALE TIE ROD WLD, 90" 94
12	6	920005	5/8 FLAT WASH SAE
13	4	900268	1/2UNC X 2 1/2 HEX BOLT
14	2	900829	5/8UNC X 4 HEX BOLT GR8
15	4	914008	1/2UNC HEX STOVER NUT
16	2	914010	5/8UNC HEX STOVER NUT

NOTE: DETAIL 11 IS USED WITH NARROW TREAD.

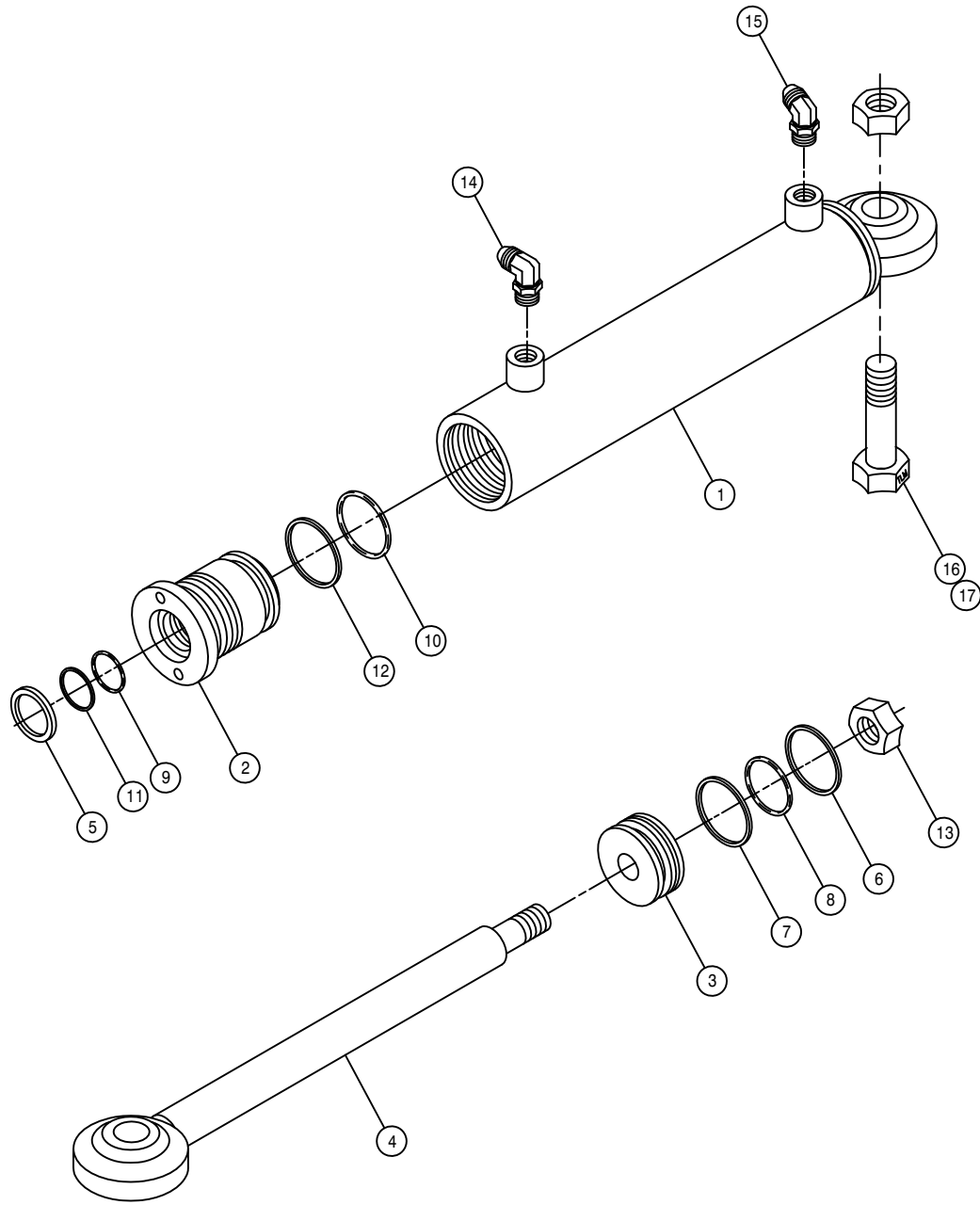

STEERING CYLINDER ASSEMBLY

DET.	QTY	PART NO.	DESCRIPTION
	1	620089	STRG CYL TUBE WLD 1.5 X 6. 85
	1	620109	GLAND HYD CYL 1.5 X .75 1985
	1	620129	PISTON HYD CYL 1.5 X .5 1985
	1	620148	STRG CYL SHAFT WLD
	1	629028	WIPER, 10D X 3/4ID X 1/8
	1	629616	SEAL, 1704-24 HT20550R POLYHON
	1	629618	WEAR RING, 1.5" HYD CYL
	1	870025	BUNA ORING 1 3/16 X 1 5/16
	1	870210	BUNA ORING 3/4 X 1
	1	870218	BUNA ORING 1 1/4 X 1 1/2
	1	890210	BACKUP WASH 3/4 X1 HT2022
	1	890218	BACKUP WASH1 1/4X1 1/2 HT2022
	1	914009	1/2UNF HEX STOVER NUT
	1	611122	9/16MJIC-90-1/4MNPT LBO
	1	618338	9/16MJIC-45-1/4MNPT LBO
	1	900336	5/8UNC X 2 1/2 HEX BOLT
	1	914010	5/8UNC HEX STOVER NUT

NOTE: 1. 620080 - CYLINDER ASSEMBLY
 2. 620998 - SEAL KIT

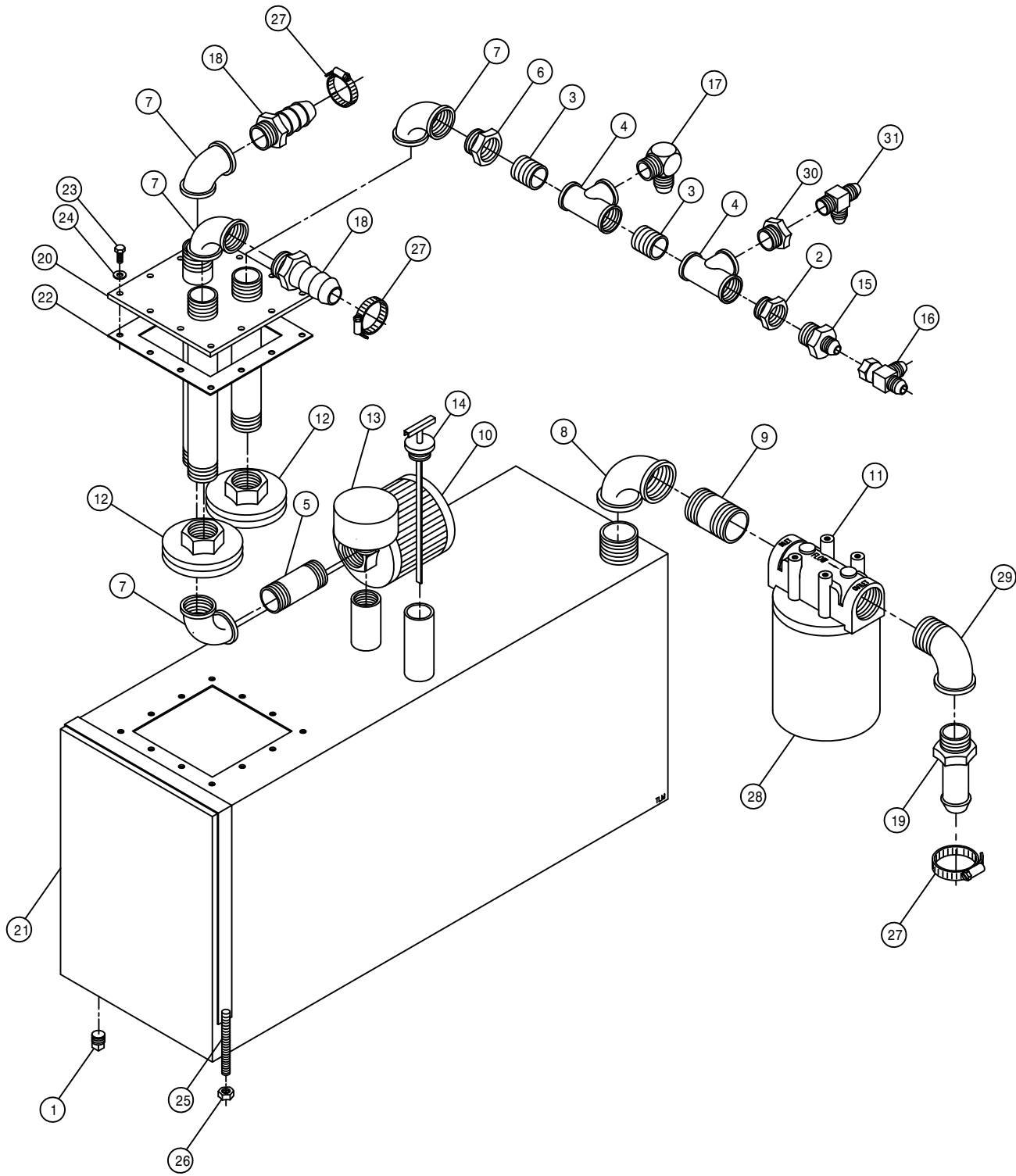

HYDRAULIC TANK ASSEMBLY

DET.	QTY	PART NO.	DESCRIPTION
1	1	501102	1/4 PIPE PLUG
2	1	504210	RED BUSH 3/4 NPT X 1/2 NPT
3	2	504702	CLOSE NIPPLE .75NPT
4	2	504955	BLK PIPE TEE .75NPT
5	1	505203	BLK PIPE NIPPLE 1.00NPT-4.00
6	1	505213	RED BUSH 1 X 3/4 BLK MAL
7	4	505300	BLK PIPE EL 90DEG 1.00NPT
8	1	506303	BLK PIPE EL 90DEG 1.25NPT
9	1	506602	PIPE NIPPLE 1 1/4NPT-2 1/2
10	1	605600	MICHIGAN RESERVOIR FILTER
11	1	605601	GRESEN FILTER 10 MICRON 40GPM
12	2	605603	LINE SUMP DIFFUSER
13	1	611052	FILLER BREATHER 3/4NPT
14	1	614453	DIPSTICK, 8IN
15	1	618018	9/16MJIC-1/2MNPT ADPTR
16	1	618486	9/16FJIC SW RUN TEE-9/16MJIC
17	1	610305	3/4MJIC-90-3/4MNPT LBO
18	2	714560	1NPT X 1 HOSE BARB
19	1	715664	1 1/4 NPT X 1 HOSE BARB
20	1	760090	RECIEVER PLT WLD 8240
21	1	760097	OIL TANK WLD 8240 1982
22	1	763039	HYD MTR MTG PLT GSKT
23	12	900064	5/16UNC X 3/4 HEX BOLT
24	12	920001	5/16 FLAT WASHER SAE PLT
25	2	341360	OIL TANK STRAP WLD 8240 1982
26	4	914004	3/8UNC HEX STOVER NUT
27	3	520087	HOSE CLAMP NO 20 PLATED
28	1	605602	FILT ELEMENT 10MICRON 40GPM
29	1	506410	BLK PIPE ST EL 90DEG 1.25NPT
30	1	504001	RED BUSH 3/4 X 1/4 BLK MAL
31	1	618520	1/4MNPT RUN TEE-9/16MJIC

DIESEL FUEL TANK ASSEMBLY

DET. QTY PART NO. DESCRIPTION

1	1	291428	FUEL SENDER 19 IN 470 PINTO
2	5	473902	NO 8 X 1/2 PAN HD MET SC 640
3	1	501102	1/4 PIPE PLUG
4	2	501451	BLK PIPE EL 90DEG .25NPT
5	1	760149	FUEL TANK WLD 200-280 90
6	1	761200	GAS CAP
7	1	783303	HOSE BARB 1/4 NPT X 5/16 HOSE
8	2	601324	HOSE, 3/8 X 90IN FUEL LINE
9	1	760153	RH FUEL TNK MT WLD 200-280 90
10	1	760154	LH FUEL TNK MT WLD 200-280 90
11	2	760162	FUEL TANK BAND WLD 200-280 90
12	1	610529	FUEL SELECTOR VALVE W/RETURN
13	1	610530	5 WIRE CONNECTOR FOR 610529
14	1	601293	HOSE, 5/16 X 26 FUEL LINE
15	1	601322	HOSE, 3/8 X 26IN FUEL LINE
16	2	601301	HOSE, 5/16 X 90IN FUEL LINE
17	10	520120	HOSE CLAMP NO 4 PLATED MINI
18	2	900064	5/16UNC X 3/4 HEX BOLT
19	2	914004	3/8UNC HEX STOVER NUT
20	4	900264	1/2UNC X 1 1/4 HEX BOLT
21	4	914008	1/2UNC HEX STOVER NUT
22	1	783304	HOSE BARB 1/4 NPT X 3/8 HOSE

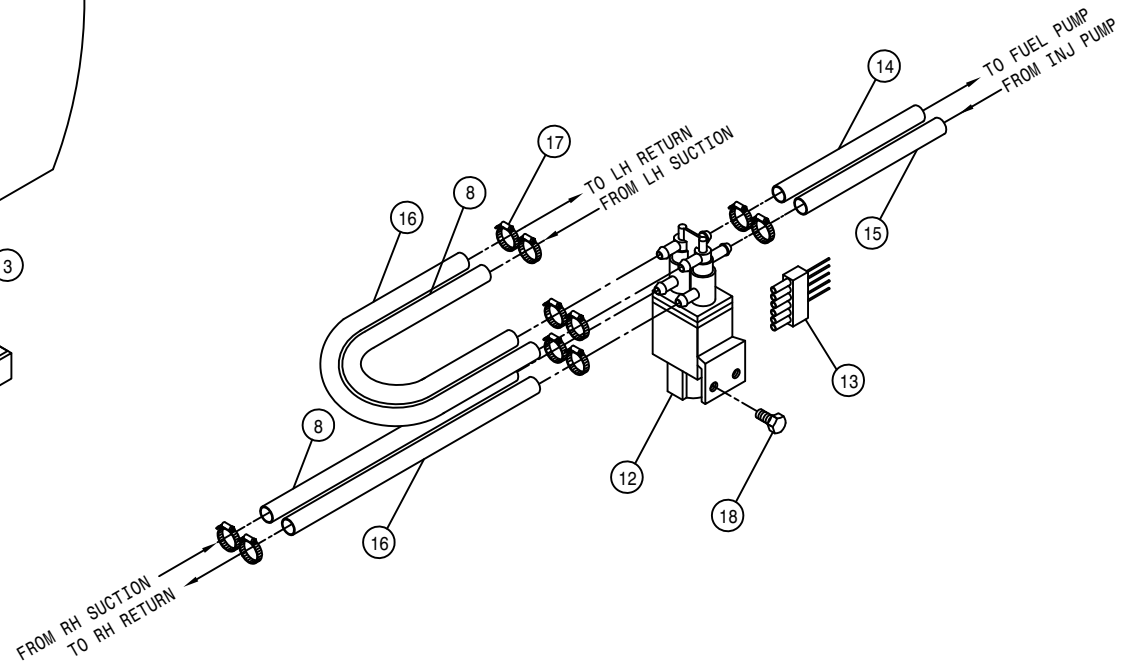
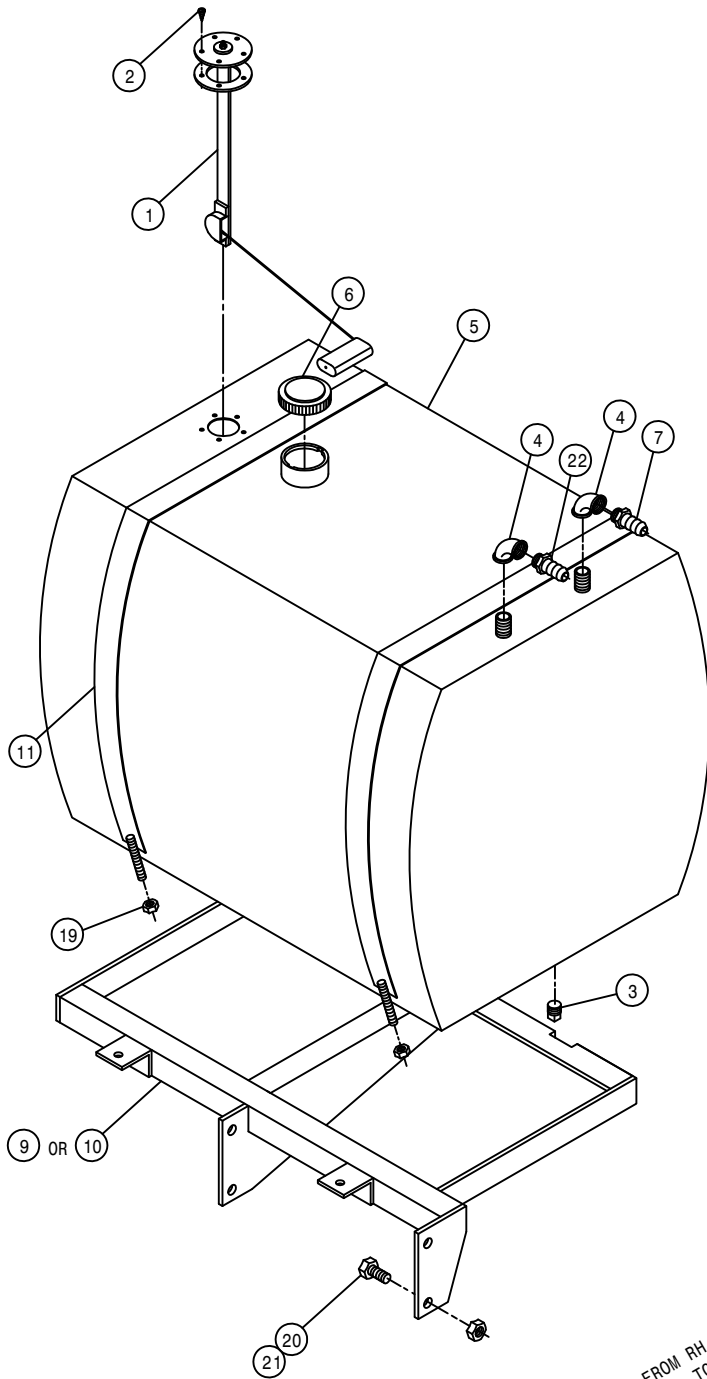

GAS FUEL TANK ASSEMBLY

DET. QTY PART NO. DESCRIPTION

1	1	291428	FUEL SENDER 19 IN 470 PINTO
2	5	473902	NO 8 X 1/2 PAN HD MET SC 640
3	1	501102	1/4 PIPE PLUG
4	1	501451	BLK PIPE EL 90DEG .25NPT
5	1	760149	FUEL TANK WLD 200-280 90
6	1	761200	GAS CAP
7	1	783303	HOSE BARB 1/4 NPT X 5/16 HOSE
8	1	319612	GAS LINE FILT NAPA3012&FRAM
9	1	760153	RH FUEL TNK MT WLD 200-280 90
10	1	760154	LH FUEL TNK MT WLD 200-280 90
11	2	760162	FUEL TANK BAND WLD 200-280 90
12	2	914004	3/8UNC HEX STOVER NUT
13	4	900264	1/2UNC X 1 1/4 HEX BOLT
14	1	601138	HOSE, 5/16 X 3 FUEL LINE
15	4	914008	1/2UNC HEX STOVER NUT
16	1	601140	HOSE, 5/16 X 22 FUEL LINE
17	4	520120	HOSE CLAMP NO 4 PLATED MINI
18	1	501100	PIPE CAP .25NPT

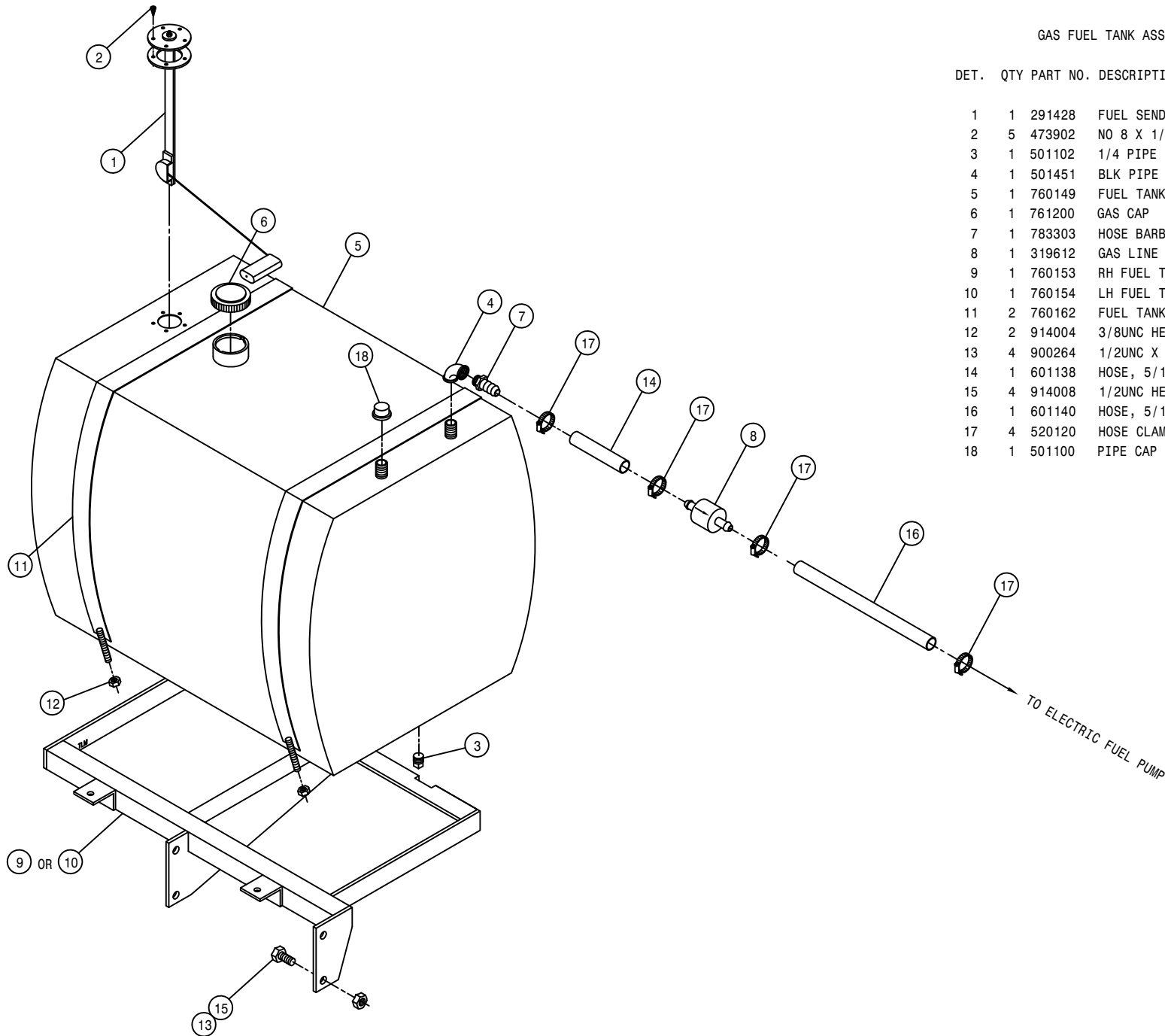

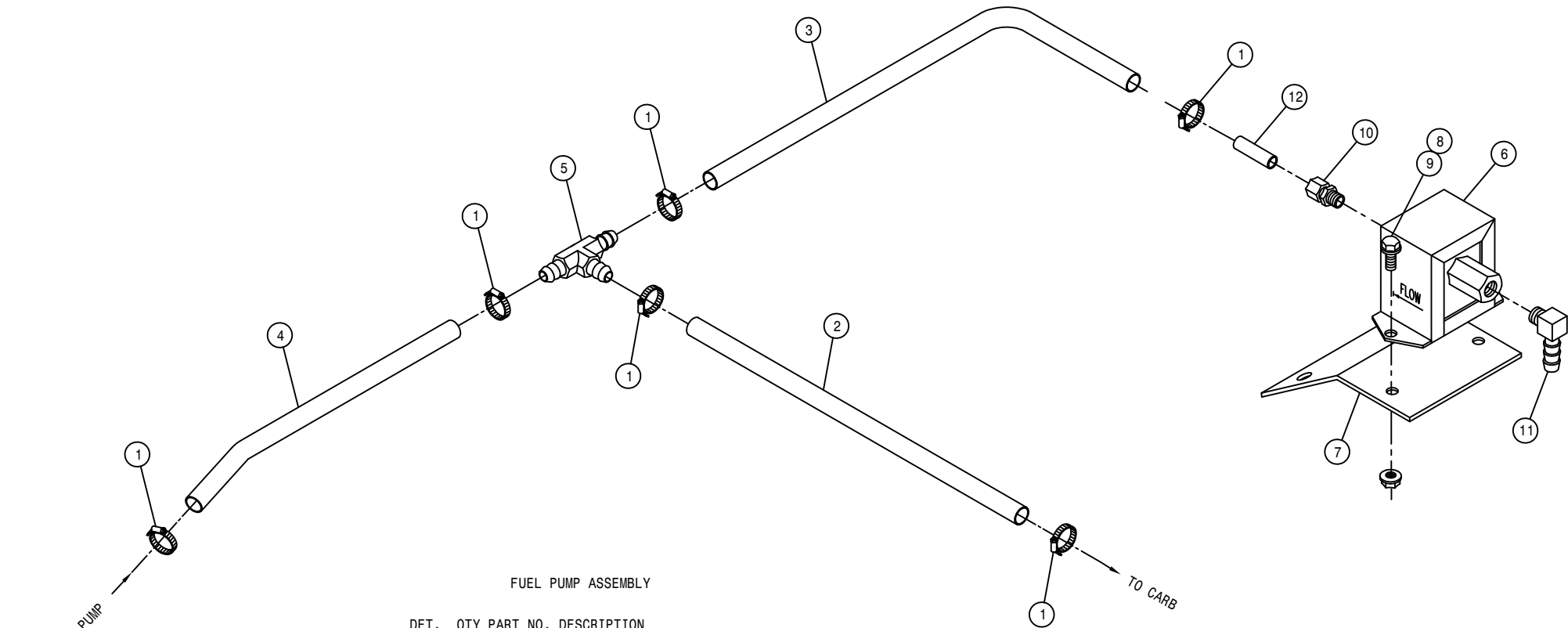

FUEL PUMP ASSEMBLY

DET.	QTY	PART NO.	DESCRIPTION
1	6	520120	HOSE CLAMP NO 4 PLATED MINI
2	1	601191	HOSE, 5/16ID X 48 FUEL
3	1	601215	HOSE, 5/16 X 72 FUEL LINE
4	1	601320	HOSE, 5/16 X 76IN FUEL LINE
5	1	711011	5/16 HOSE BARB TEE, BRASS
6	1	314882	ELECTRONIC FUEL PUMP CHRY 91
7	1	342015	FUEL PUMP MT PLT 200 92
8	6	470121	1/4UNC HEX FLANGED LOCK NUT
9	6	470122	1/4UNC X 1/2 FLANGED HEX BOLT
10	1	711012	BALL CHECK CONNECT,1/8NPT BRS
11	1	711010	5/16 HOSE BARB-90-1/8MNPT BRS
12	1	314527	FUEL FILT H BARB 647 PERK
13	1	342016	FUEL PUMP SHIELD 200 92

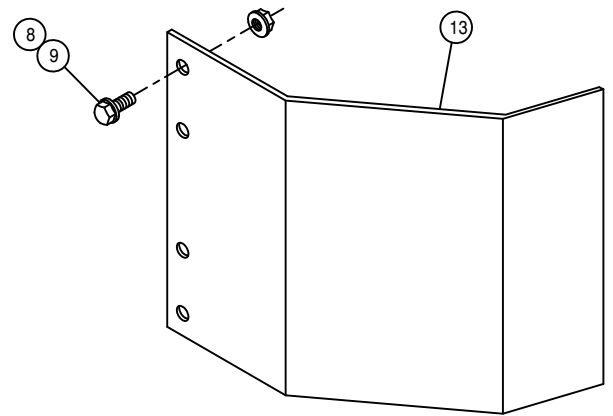

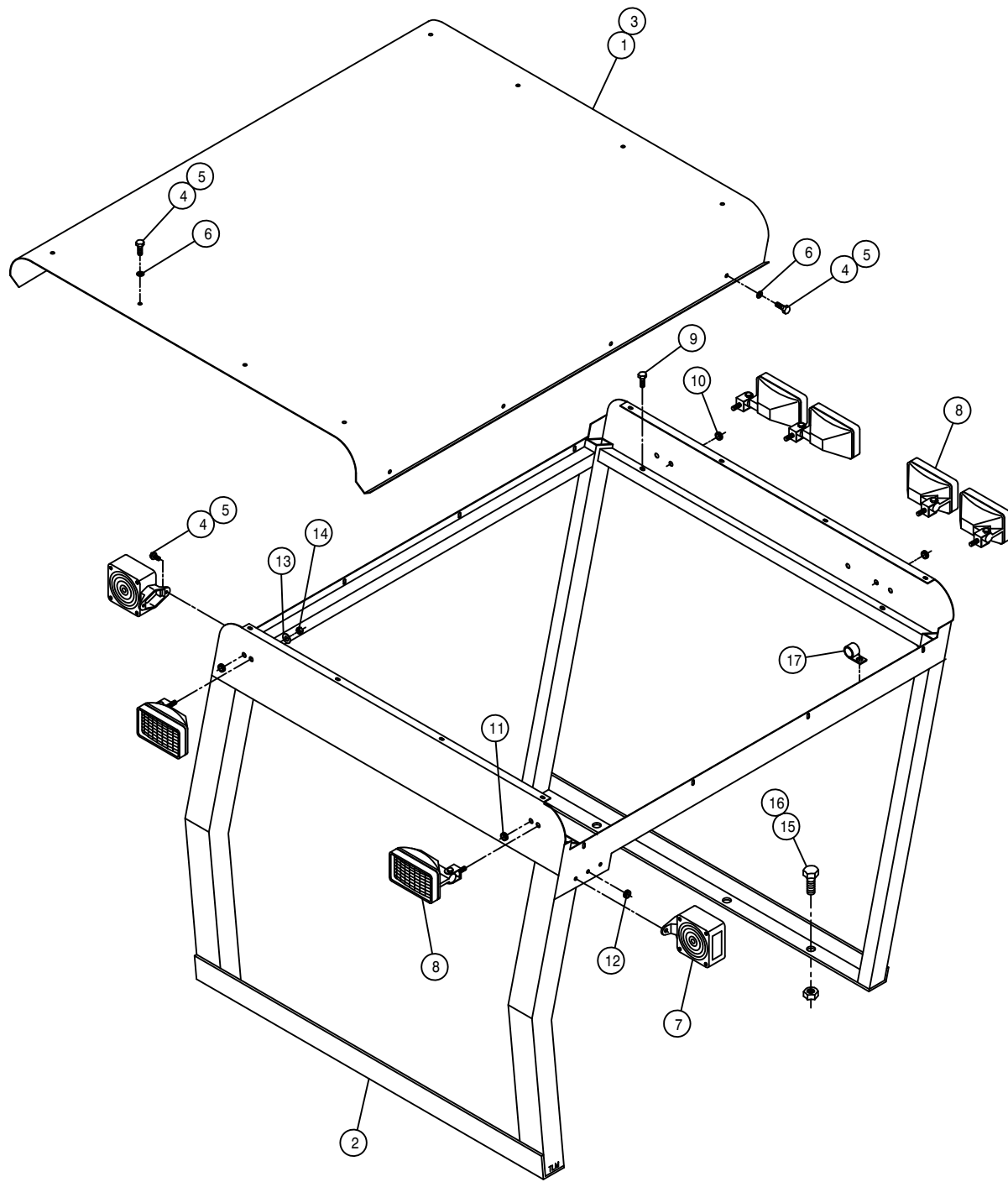

CANOPY ASSEMBLY

DET.	QTY	PART NO.	DESCRIPTION	
1	1	342151	CAB ROOF, 284	94
2	1	342270	CANOPY WLD, 204	94
3	1	658314	CANOPY ROOF FOAM, 204	94
4	20	470122	1/4UNC X 1/2 FLANGED HEX BOLT	
5	20	470121	1/4UNC HEX FLANGED LOCK NUT	
6	16	470212	1/4 BONDED NEO SEALING WASH	
7	2	291604	TURN SIGNAL LIGHT, PED MT, YEL	
8	6	291603	WORKLAMP, SIDE MT 12V HALOGEN	
9	4	472349	1/4 X 3/4 20THD-IN TEK TYPE	
10	2	470067	RUBBER GROMMET 1/4 ID	
11	2	470070	RUBBER GROMMET 3/8 ID	
12	2	470226	RUBBER GROMMET 5/32 ID	
13	6	470100	LOCKWASH, .38 INT TOOTH	
14	6	473779	10MM-1.50 HEX NUT	
15	6	900264	1/2UNC X 1 1/4 HEX BOLT	
16	6	914008	1/2UNC HEX STOVER NUT	
17	6	520117	CUSH HOSE CLAMP 5/8D X 1/2W	

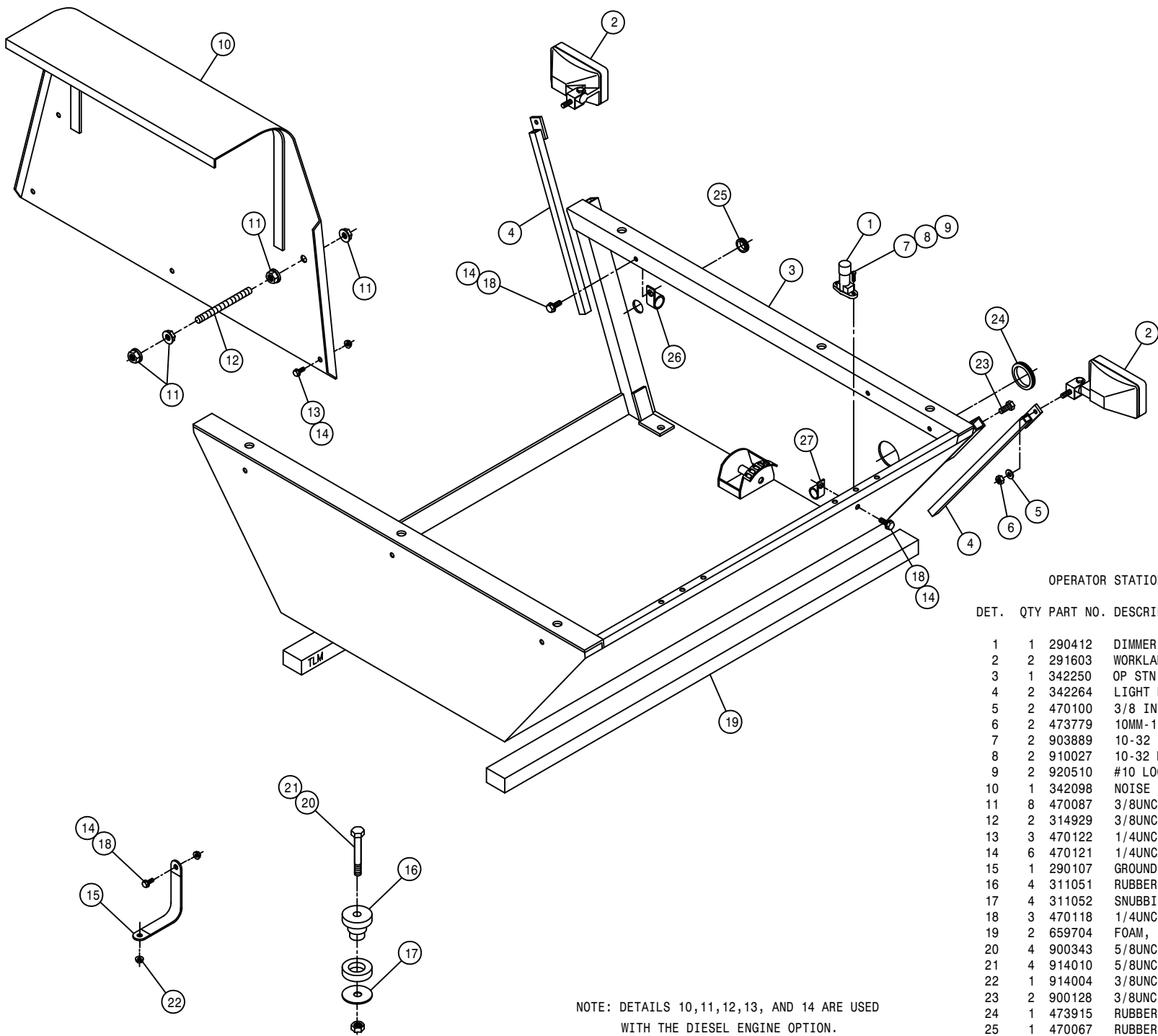

OPERATOR STATION ASSEMBLY

DET.	QTY	PART NO.	DESCRIPTION
1	1	290412	DIMMER SWITCH
2	2	291603	WORKLAMP, SIDE MT 12V HALOGEN
3	1	342250	OP STN WLD, 204 94
4	2	342264	LIGHT MT WLD, 204 94
5	2	470100	3/8 INT TOOTH LOCK WASHER
6	2	473779	10MM-1.50 HEX NUT
7	2	903889	10-32 X 3/4 SLT RDHD MACH SCR
8	2	910027	10-32 HEX NUT
9	2	920510	#10 LOCK WASHER
10	1	342098	NOISE DEFLECTOR SHIELD WLD,204
11	8	470087	3/8UNC HEX FLANGE LOCK NUT
12	2	314929	3/8UNC X 3.00 STUD BOLT, FULL
13	3	470122	1/4UNC X 1/2 FLANGE HEX BOLT
14	6	470121	1/4UNC HEX FLANGE LOCK NUT
15	1	290107	GROUND STRAP 8 IN
16	4	311051	RUBBER MOUNT, RB3-350
17	4	311052	SNUBBING WASHER FOR 311051
18	3	470118	1/4UNC X 3/4 FLANGE HEX BOLT
19	2	659704	FOAM, 2"THK X 2" WIDE X 42"LG
20	4	900343	5/8UNC X 4 1/2 HEX BOLT
21	4	914010	5/8UNC HEX STOVER NUT
22	1	914004	3/8UNC HEX STOVER NUT
23	2	900128	3/8UNC X 3/4 HEX BOLT
24	1	473915	RUBBER GROMMET 1 1/2 ID
25	1	470067	RUBBER GROMMET 1/4 ID
26	2	520118	CUSH HOSE CLAMP 1/2D X 1/2W
27	1	520121	CUSH HOSE CLAMP 1IN X 3/4W

NOTE: DETAILS 10,11,12,13, AND 14 ARE USED WITH THE DIESEL ENGINE OPTION.

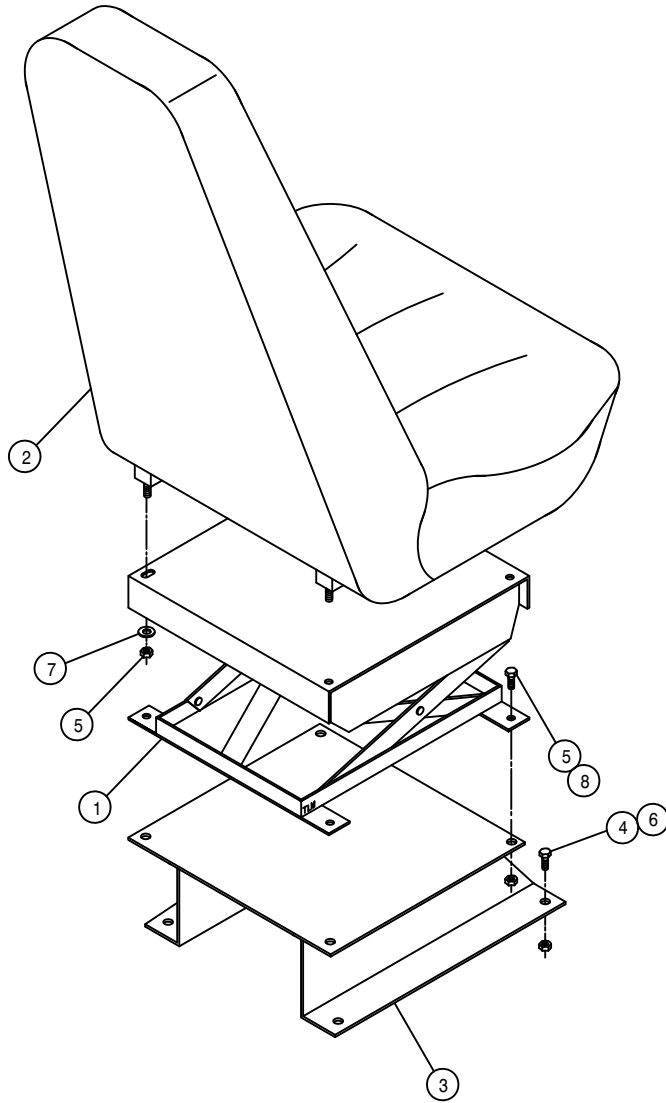

SEAT ASSEMBLY

DET. QTY PART NO. DESCRIPTION

1	1	330015	SUSPENSION ASSY TRIMLINE SEAT
2	1	330017	TRIMLINE SEAT, MID HIGH, VINYL
3	1	341554	SEAT MT WLD TRIMLINE SEAT
4	4	900129	3/8UNC X 1 HEX BOLT
5	8	914002	5/16UNC HEX STOVER NUT
6	4	914004	3/8UNC HEX STOVER NUT
7	2	920001	5/16 FLAT WASHER SAE PLT
8	4	900064	5/16UNC X 3/4 HEX BOLT

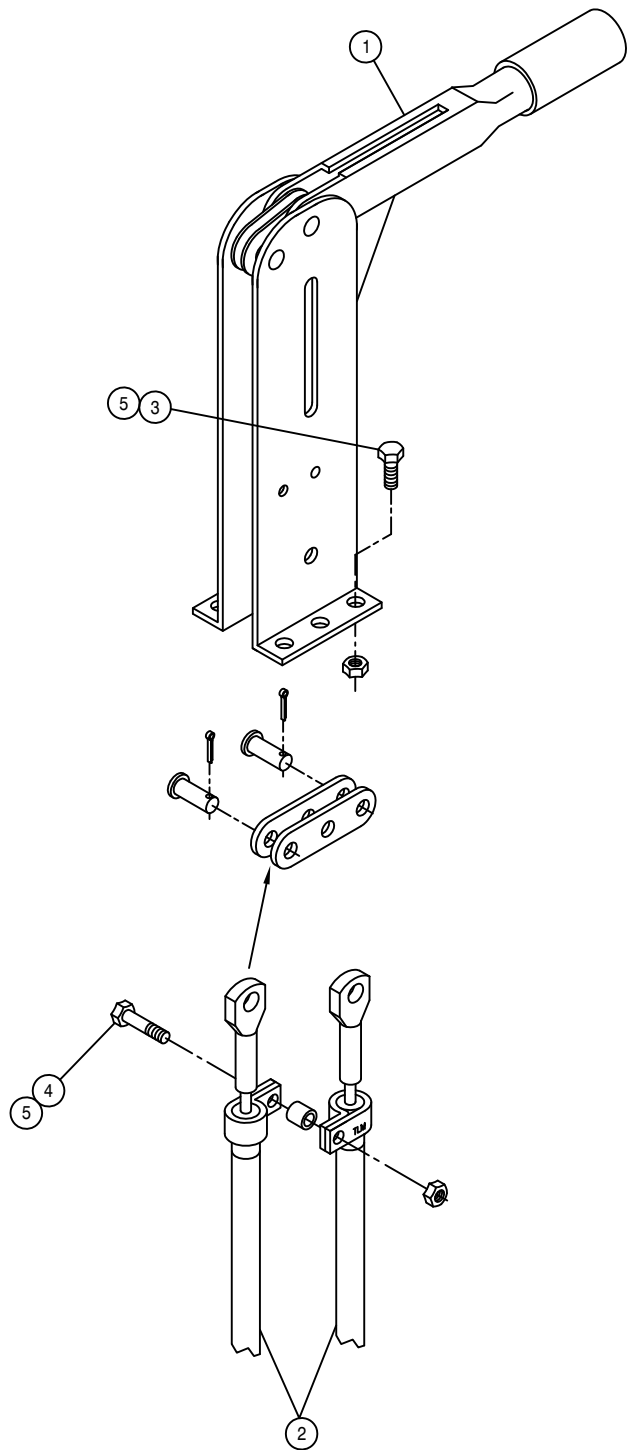

BRAKE LEVER ASSEMBLY

DET. QTY PART NO. DESCRIPTION

1	1	826108	BRAKE LEVER ASSY
2	2	826926	190 IN BRAKE CABLE
3	4	900064	5/16UNC X 3/4 HEX BOLT
4	1	900067	5/16UNC X 1 1/2 HEX BOLT
5	5	914002	5/16UNC HEX STOVER NUT

STEERING POST ASSEMBLY

DET. QTY PART NO. DESCRIPTION

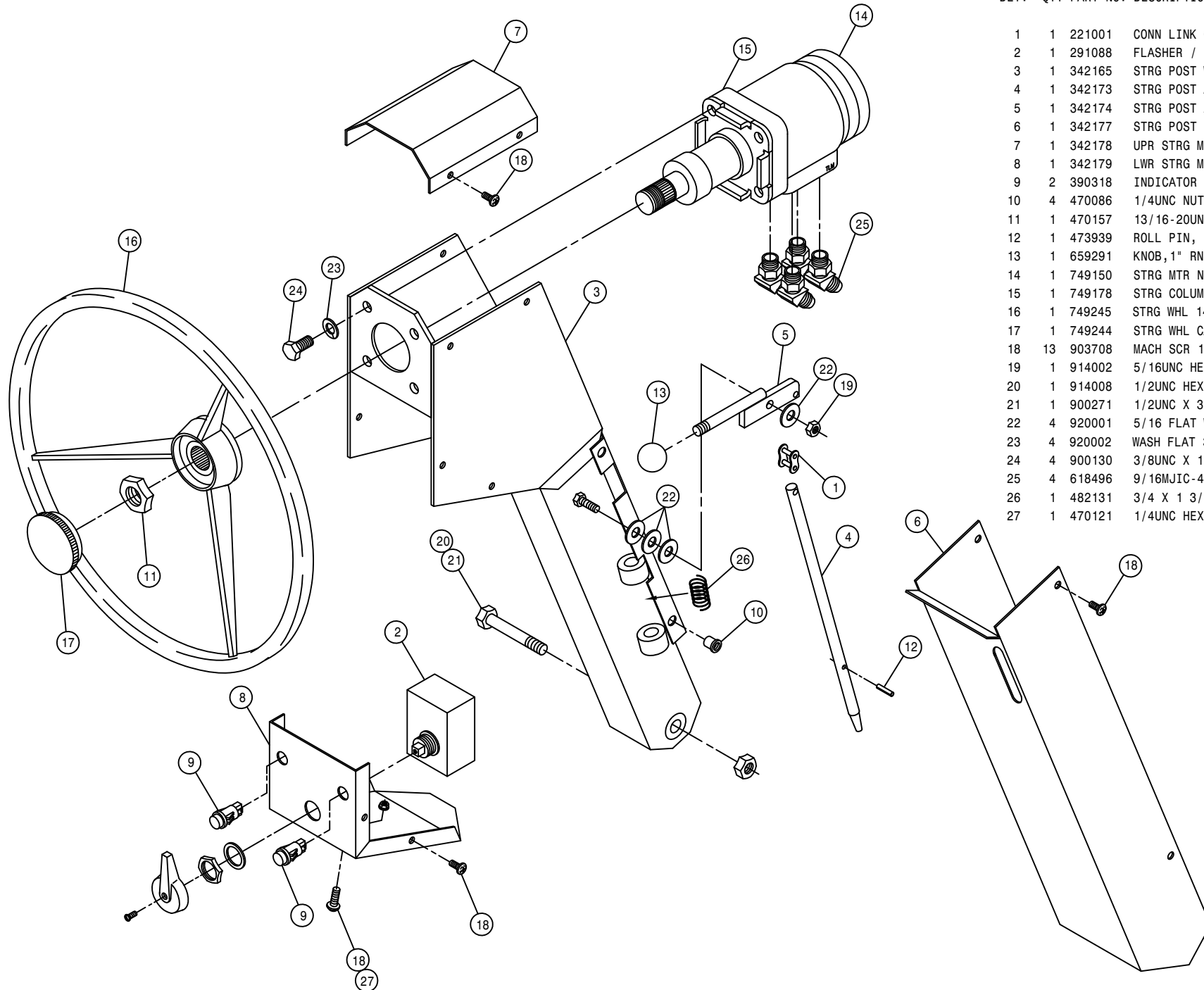

DET.	QTY	PART NO.	DESCRIPTION
1	1	221001	CONN LINK CLIP TYPE RC50
2	1	291088	FLASHER / TURN SIGNAL SWITCH
3	1	342165	STRG POST WLD, 284 CAB 94
4	1	342173	STRG POST ADJ PIN, 284 CAB 94
5	1	342174	STRG POST ADJ PIN LEVER WLD94
6	1	342177	STRG POST COVER, 284 CAB 94
7	1	342178	UPR STRG MTR HSG COVER 94
8	1	342179	LWR STRG MTR HSG COVER 94
9	2	390318	INDICATOR LIGHT RED SNAP-IN
10	4	470086	1/4UNC NUTSERT .020-.100MATL
11	1	470157	13/16-20UNEF HEX NUT STRG WHL
12	1	473939	ROLL PIN, 3/16DIA X 7/8
13	1	659291	KNOB, 1" RND, BLK, 3/8-16
14	1	749150	STRG MTR NON-LOAD REACT 1008
15	1	749178	STRG COLUMN 2.5IN LONG
16	1	749245	STRG WHL 14.0 DIA
17	1	749244	STRG WHL CAP FOR 749245
18	13	903708	MACH SCR 1/4-20X1/2 PHIL PNHD
19	1	914002	5/16UNC HEX STOVER NUT
20	1	914008	1/2UNC HEX STOVER NUT
21	1	900271	1/2UNC X 3 1/4 HEX BOLT
22	4	920001	5/16 FLAT WASHER SAE PLT
23	4	920002	WASH FLAT 3/8 SAE
24	4	900130	3/8UNC X 1 1/4 HEX BOLT
25	4	618496	9/16MJIC-45-3/4MOR LBO
26	1	482131	3/4 X 1 3/4 COMPRSN SPRING
27	1	470121	1/4UNC HEX FLANGED LOCK NUT

INSTRUMENT PANEL ASSEMBLY

DET.	QTY	PART NO.	DESCRIPTION
1	1	290401	FUEL GAUGE FOR 2.125 DIA HOLE
2	1	291203	HOUR METER
3	1	291609	OIL PRESS GAUGE, 80PSI
4	1	291611	VOLTMETER, 8V TO 18V DC
5	4	291612	LIGHT KIT FOR 2" GAUGE
6	1	291641	DIGITAL MPH/RPM INDICATOR W/P
7	1	314436	TEMP GA 100-280 DEG LIGHTED
8	1	342068	DIGITAL MPH/RPM IND KEEPER 94
9	1	342232	INSTRUMENT PANEL, 204 94
10	1	342233	INSTRUMENT HSG WLD, 204 94
11	1	390318	INDICATOR LIGHT RED SNAP-IN
12	1	470204	RUBBER GORMMET 1.0ID 1 3/8GR
13	1	470224	SNAP PLUG, BLK NYL, .50 DIA
14	8	473802	NO 8 INT TOOTH STARWASHER
15	1	629728	FINISH PLUG FOR 2.12 HOLE
16	4	903710	MACH SCR 10-32X1/2 PHIL PANHD
17	8	910024	#8-32 HEX NUT
18	1	314901	FILTER MINDER AIR RESTRICT GA
19	4	470165	#10-32 NUTSERT .020-.100 MATL
20	2	193011	EDGE GUARD, BLK
21	2	900263	1/2UNC X 1 HEX BOLT
22	2	920504	LOCK WASH 1/2

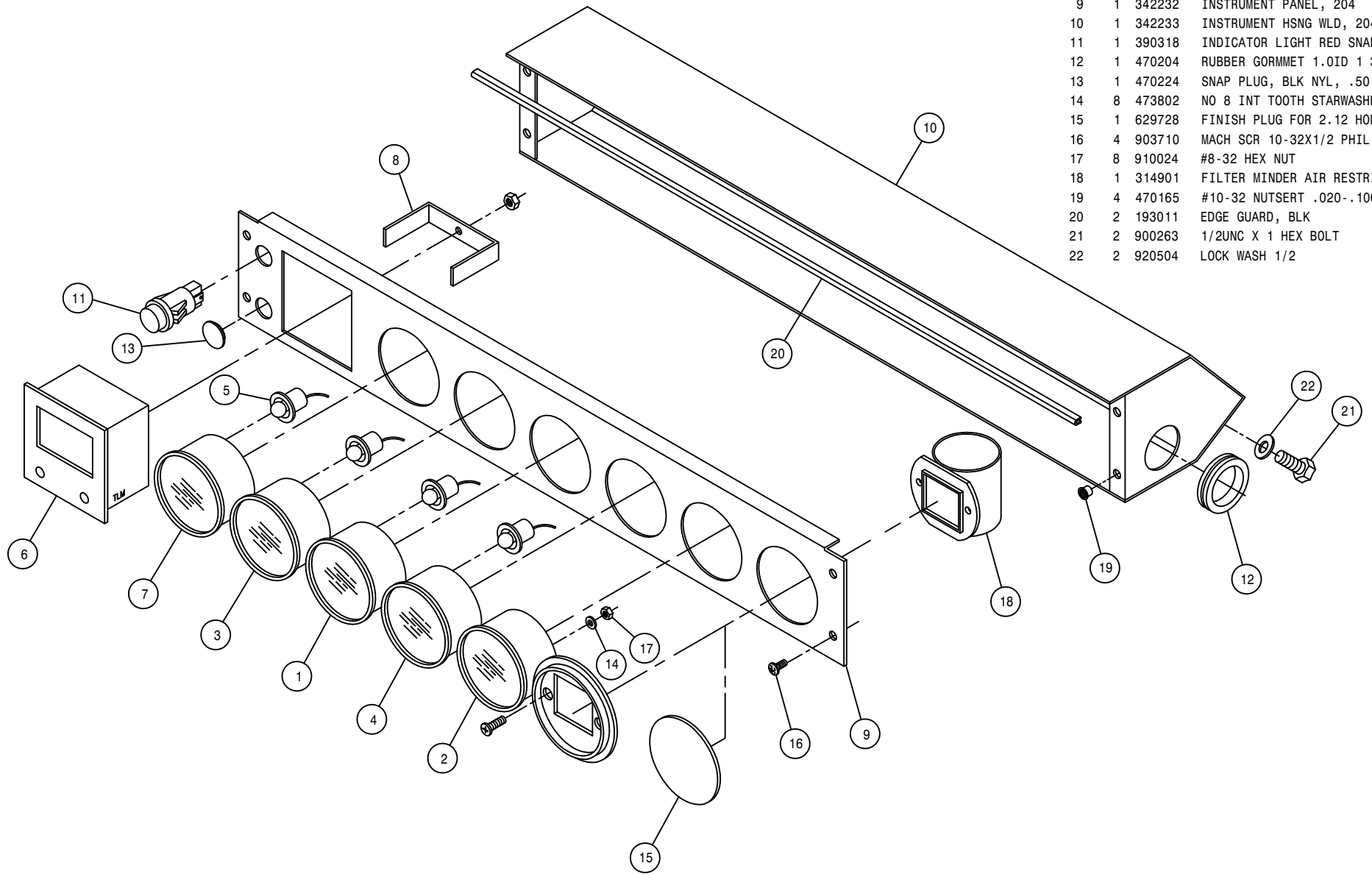

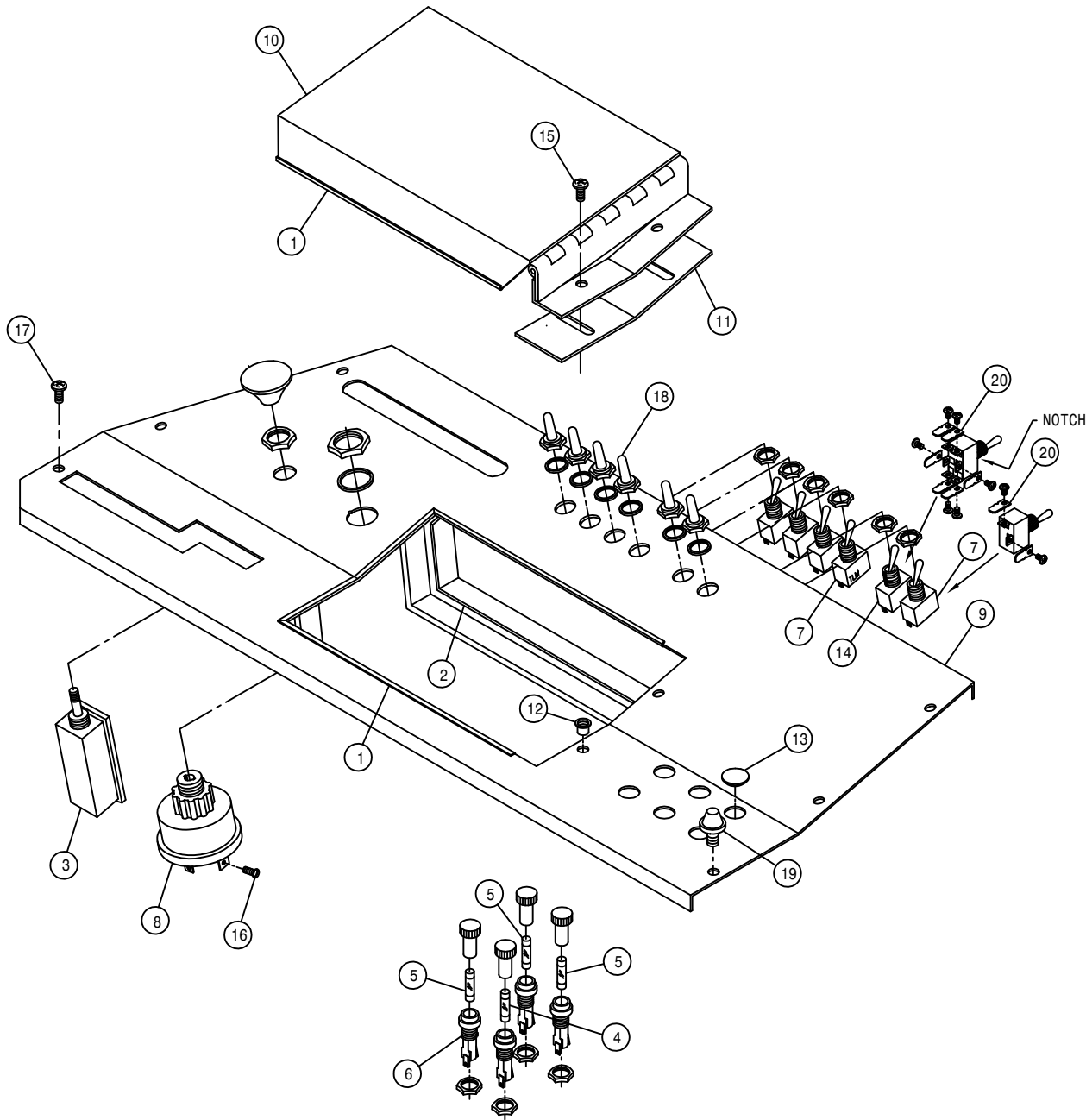

CONSOLE PANEL ASSEMBLY

DET.	QTY	PART NO.	DESCRIPTION	
	2	193011	EDGE GUARD, BLK	
	2	193037	STICKERTITE 1/8 X 3/4	
	1	290046	LIGHT SWITCH TWO POSITION	
	1	291602	FUSE 10 AMP	
	3	298004	20 AMP FUSE SFE 20	
	4	298011	FUSE HOLDER	
	5	298012	TOGGLE SWITCH	
	1	321020	IGN SWITCH 5 POLE	
	1	342237	CONSOLE PANEL WLD, 204	94
	1	342240	CONTROL BOX COVER WLD, 204	94
	1	342244	CONTROL BOX KEEPER, 204	94
	2	470165	#10-32 NUTSERT .020-.100 MATL	
	2	470224	SNAP PLUG, BLK NYL, .50 DIA	
	1	610412	TOGGLE SWITCH FOR FUEL VLV	
	2	903710	MACH SCR 10-32X1/2 PHIL PANHD	
	1	903844	8-32 X 1/2 SLTRDHD MACH SCREW	
	5	903708	MACH SCR 1/4-20X1/2 PHIL PNHD	
	6	470001	RUBBER BOOT W NUT FOR 298012	
	1	470230	1/2 RUBBER BUMPER, 1/4-20 STUD	
	8	291644	.250MALE FASTON-#6 RING ADAPT	

CONSOLE ASSEMBLY

DET. QTY PART NO. DESCRIPTION

1	1	293093	TERMINAL BLOCK 6 POS - 2 ROW
2	1	342248	CONSOLE BRACE, 204 94
3	1	342216	DRINK HOLDER MT BRKT 94
4	6	470086	1/4UNC NUTSERT .020-.100MATL
5	2	470175	#10-32 HEX FLANGED LOCK NUT
6	1	470214	SPILLMASTER DRINK HOLDER
7	4	473902	NO 8 X 1/2 PAN HD MET SC
8	1	342245	CONSOLE WLD, 204 94
9	1	291024	CIRCUIT BREAKER, 40AMP
10	4	470121	1/4UNC HEX FLANGED LOCK NUT
11	3	470118	1/4UNC X 3/4 FLANGED HEX BOLT
12	2	903710	MACH SCR 10-32X1/2 PHIL PANHD
13	2	903812	6-32 X 1/2 SLT RD HD MACH SCR
14	2	903814	6-32 X 3/4 SLT RD HD MACH SCR
15	4	910022	#6-32 HEX NUT
16	1	780101	CHOKE CONTROL CABLE, 144 IN
17	1	470231	1/4UNC X 1 FLANGED HEX BOLT

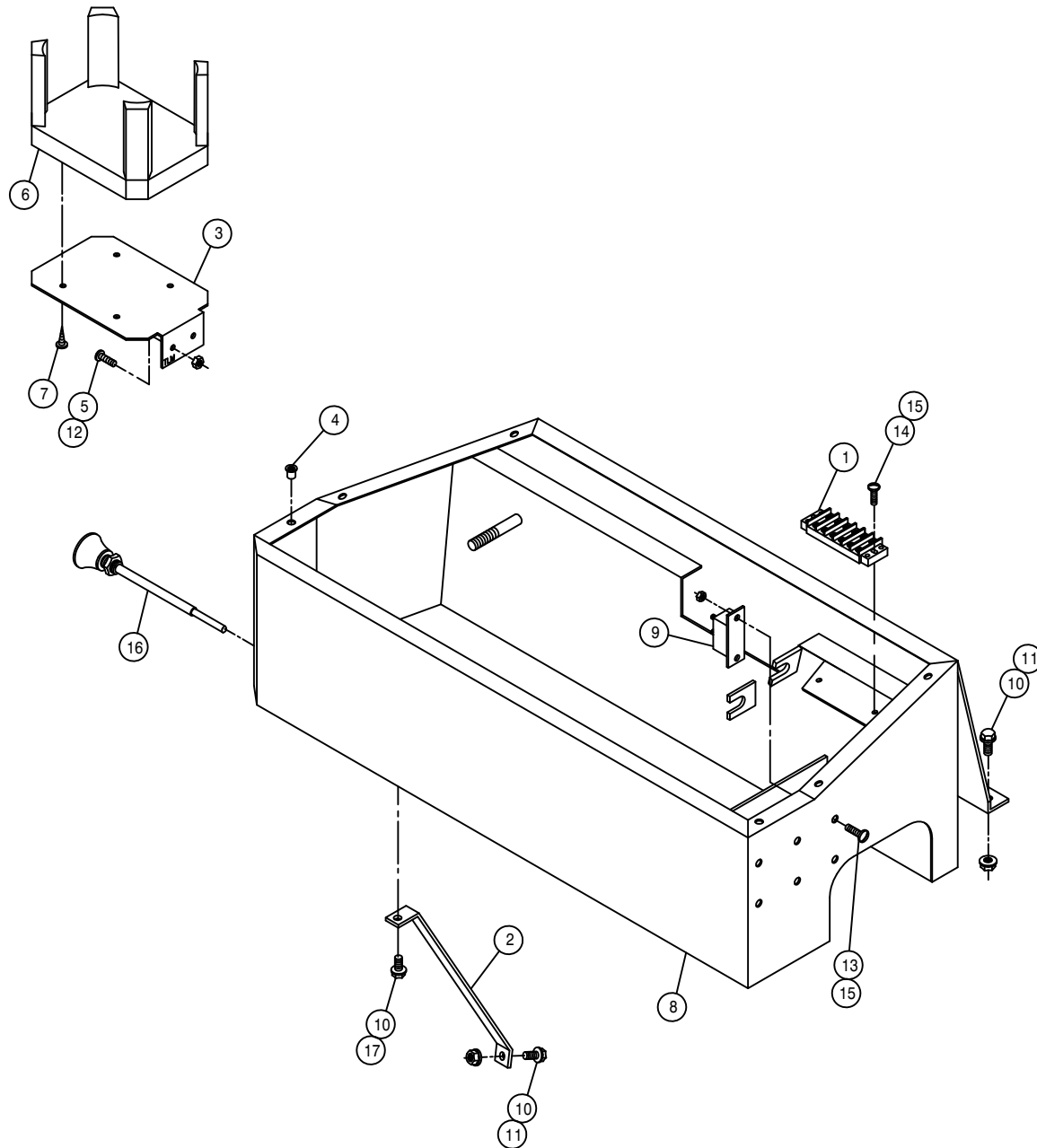

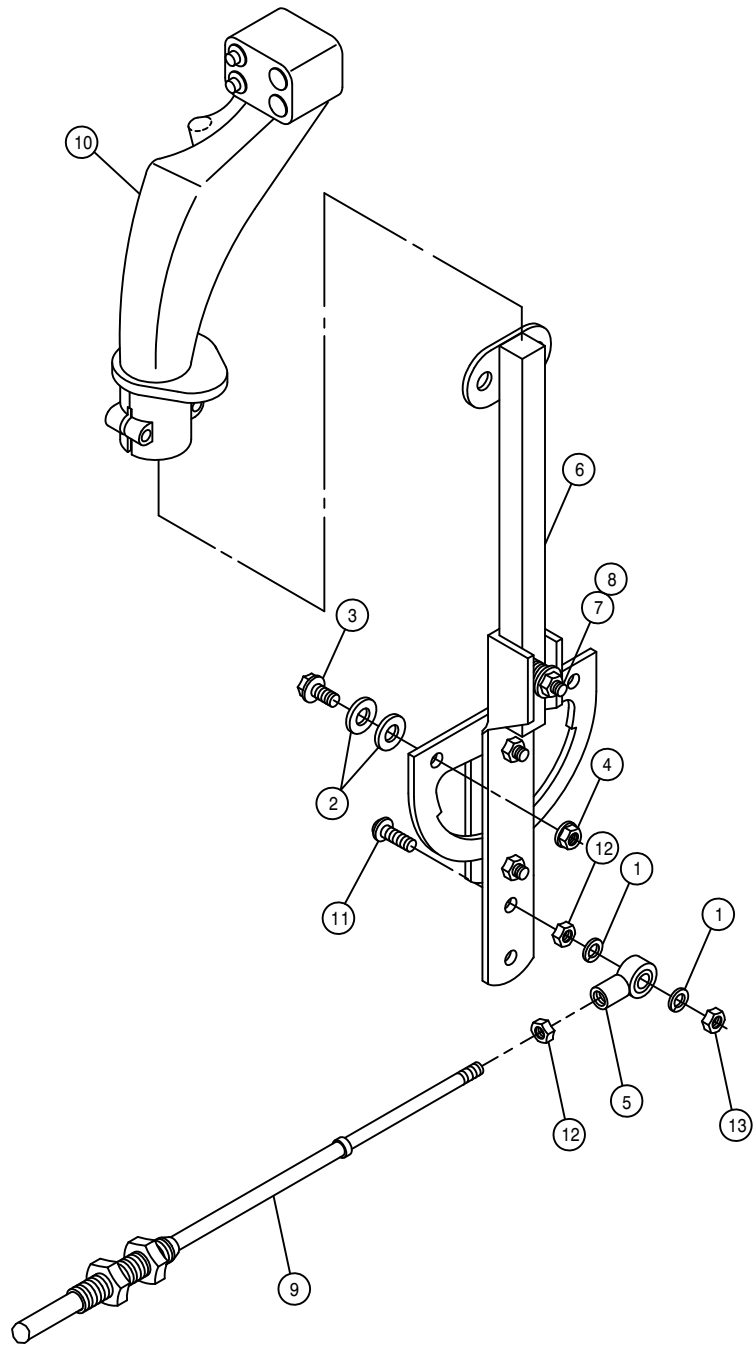

HYDROSTATIC LEVER ASSEMBLY

DET.	QTY	PART NO.	DESCRIPTION
	1	2	920510 LOCK WASH NO 10
	2	4	920000 1/4 FLAT WASH SAE
	3	2	470118 1/4UNC X 3/4 FLANGED HEX BOLT
	4	2	470121 1/4UNC HEX FLANGED LOCK NUT
	5	1	473921 BALL JOINT NO 10-32 THD
	6	1	606907 HYDST CTRL LEVER, 204-284 94
	7	1	900005 1/4UNC X 1 1/2 HEX BOLT
	8	1	914000 1/4UNC HEX STOVER NUT
	9	1	785003 CTRL CABLE 10-32 4IN X 112 LG
	10	1	785077 FASSE EZ-3 CONTROL HANDLE, 204
	11	1	903893 10 32 X 1 SLT RD HD MACH SCR
	12	2	910027 #10-32 HEX NUT
	13	1	914027 #10-32 HEX STOVER NUT

THROTTLE LEVER ASSEMBLY

DET. QTY PART NO. DESCRIPTION

1	1	499001	SPRING HYDRO CONTROL
2	1	785007	KNOB,1 3/16" BALL,RED,3/8-16
3	1	785046	FRICTION DISC 3-333 X .38
4	1	785066	CTRL CABLE 10-32 4IN X 129 IN
5	1	785067	THROT LEVER WLD,GAS/DIESEL 94
6	1	903893	10 32 X 1 SLT RD HD MACH SCR
7	2	910027	#10-32 HEX NUT
8	1	914004	3/8UNC HEX STOVER NUT
9	1	914027	#10-32 HEX STOVER NUT
10	1	920002	WASH FLAT 3/8 SAE
11	2	920510	LOCK WASH NO 10
12	1	473921	BALL JOINT NO 10-32 THD

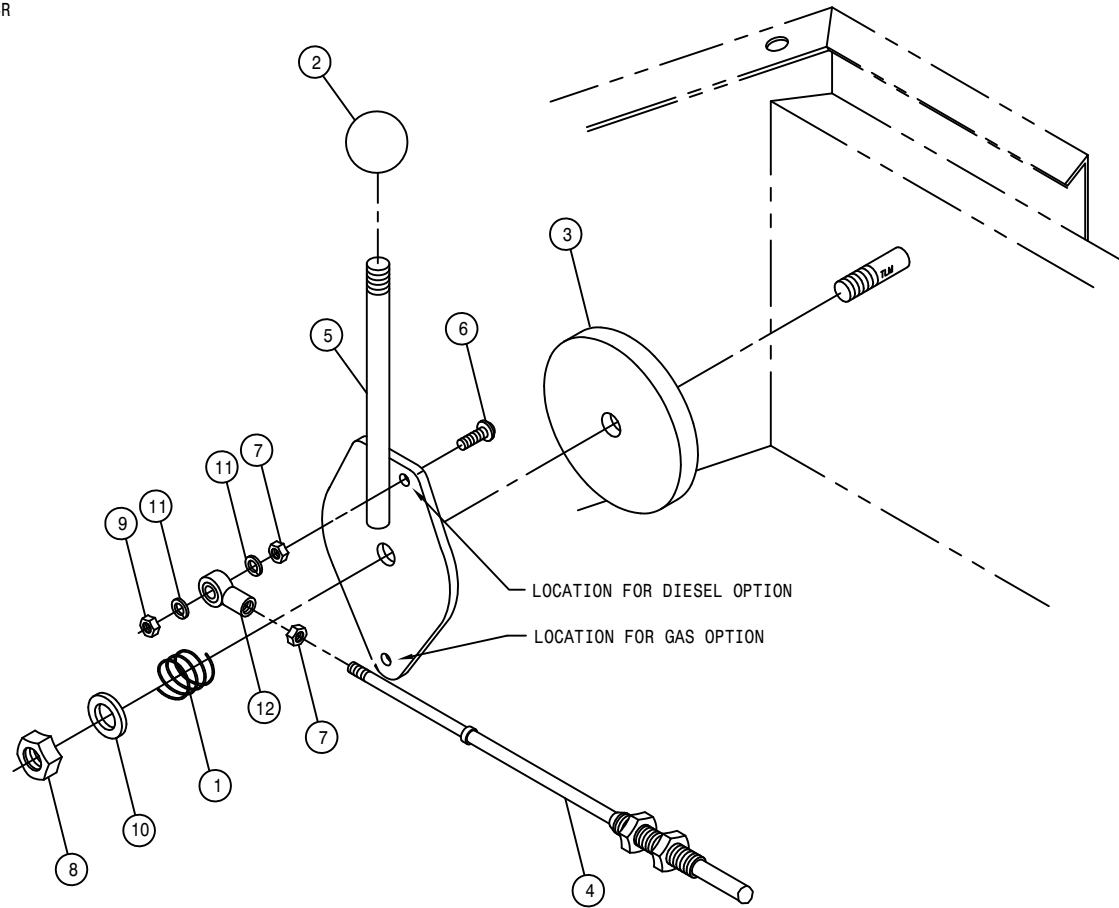

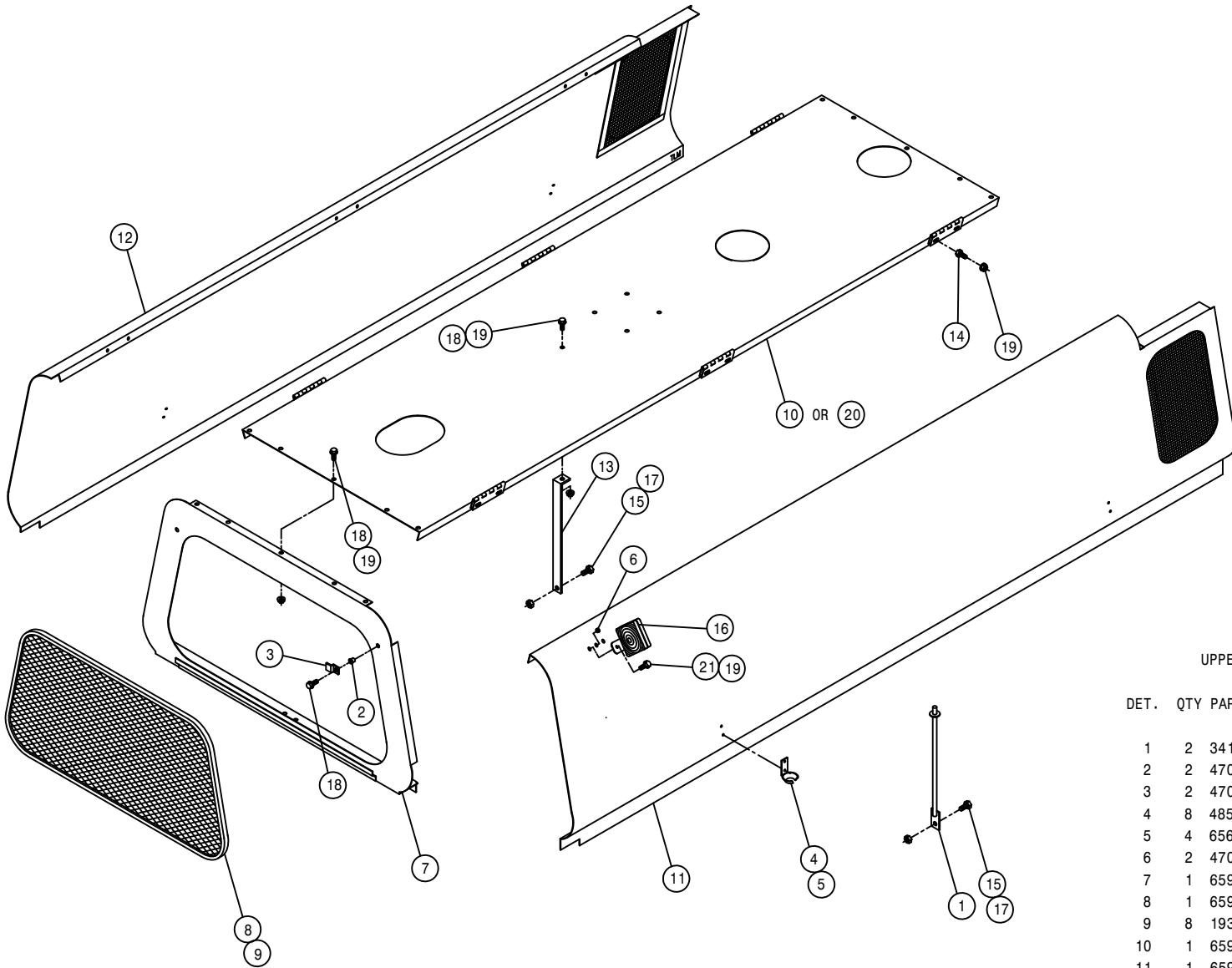

UPPER SHEET METAL ASSEMBLY

DET.	QTY	PART NO.	DESCRIPTION
	1	2	341356 ENGINE HOOD PROP WLD 8240 82
	2	2	470086 1/4UNC NUTSERT .020-.100MATL
	3	2	470151 UPPER REAR PANEL SCREEN CLIP
	4	8	485053 POP RIVET 3/16 X 3/8
	5	4	656997 RUBBER HOOK BRKT 473
	6	2	470067 RUBBER GROMMET 1/4 ID
	7	1	659575 UPPER REAR PANEL WLD 8240 82
	8	1	659578 UPPER REAR PANEL SCREEN 8240
	9	8	193016 QUICKEDGE TRIM .060 TO .170
	10	1	659909 MULLION WLD, 204 CHR Y 5.2L 94
	11	1	659911 RH ENG HOOD WLD, 204 94
	12	1	659912 LH ENG HOOD WLD, 204 94
	13	1	659835 MULLION SUPPORT 200 89
	14	12	900000 1/4UNC X 1/2 HEX BOLT
	15	3	900128 3/8UNC X 3/4 HEX BOLT
	16	2	291604 TURN SIGNAL LIGHT,PED MT, YEL
	17	3	914004 3/8UNC HEX STOVER NUT
	18	13	470118 1/4UNC X 3/4 FLANGED HEX BOLT
	19	27	470121 1/4UNC HEX FLANGED LOCK NUT
	20	1	659915 MULLION WLD CUMM 204/284 95
	21	4	470122 1/4UNC X 1/2 FLANGED HEX BOLT

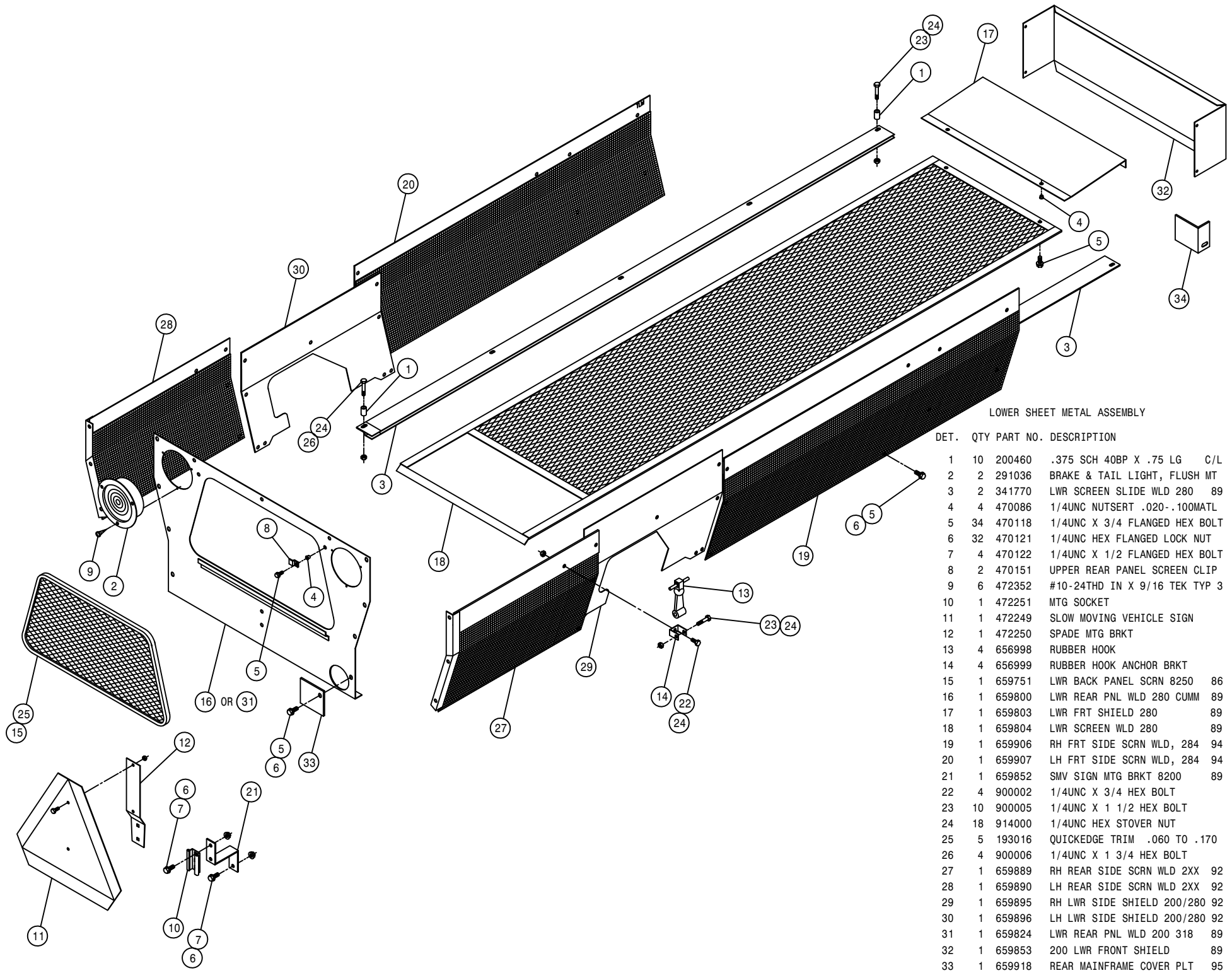

LOWER SHEET METAL ASSEMBLY

DET.	QTY	PART NO.	DESCRIPTION	
1	10	200460	.375 SCH 40BP X .75 LG	C/L
2	2	291036	BRAKE & TAIL LIGHT, FLUSH MT	
3	2	341770	LWR SCREEN SLIDE WLD 280	89
4	4	470086	1/4UNC NUTSERT .020-.100MATL	
5	34	470118	1/4UNC X 3/4 FLANGED HEX BOLT	
6	32	470121	1/4UNC HEX FLANGED LOCK NUT	
7	4	470122	1/4UNC X 1/2 FLANGED HEX BOLT	
8	2	470151	UPPER REAR PANEL SCREEN CLIP	
9	6	472352	#10-24THD IN X 9/16 TEK TYP 3	
10	1	472251	MTG SOCKET	
11	1	472249	SLOW MOVING VEHICLE SIGN	
12	1	472250	SPADE MTG BRKT	
13	4	656998	RUBBER HOOK	
14	4	656999	RUBBER HOOK ANCHOR BRKT	
15	1	659751	LWR BACK PANEL SCRNL 8250	86
16	1	659800	LWR REAR PNL WLD 280 CUMM	89
17	1	659803	LWR FRT SHIELD 280	89
18	1	659804	LWR SCREEN WLD 280	89
19	1	659906	RH FRT SIDE SCRNL WLD, 284	94
20	1	659907	LH FRT SIDE SCRNL WLD, 284	94
21	1	659852	SMV SIGN MTG BRKT 8200	89
22	4	900002	1/4UNC X 3/4 HEX BOLT	
23	10	900005	1/4UNC X 1 1/2 HEX BOLT	
24	18	914000	1/4UNC HEX STOVER NUT	
25	5	193016	QUICKEDGE TRIM .060 TO .170	
26	4	900006	1/4UNC X 1 3/4 HEX BOLT	
27	1	659889	RH REAR SIDE SCRNL WLD 2XX	92
28	1	659890	LH REAR SIDE SCRNL WLD 2XX	92
29	1	659895	RH LWR SIDE SHIELD 200/280	92
30	1	659896	LH LWR SIDE SHIELD 200/280	92
31	1	659824	LWR REAR PNL WLD 200 318	89
32	1	659853	200 LWR FRONT SHIELD	89
33	1	659918	REAR MAINFRAME COVER PLT	95
34	1	659917	FRT MAINFRAME COVER PLT	95

GAS ENGINE OPTION

DIESEL ENGINE OPTION

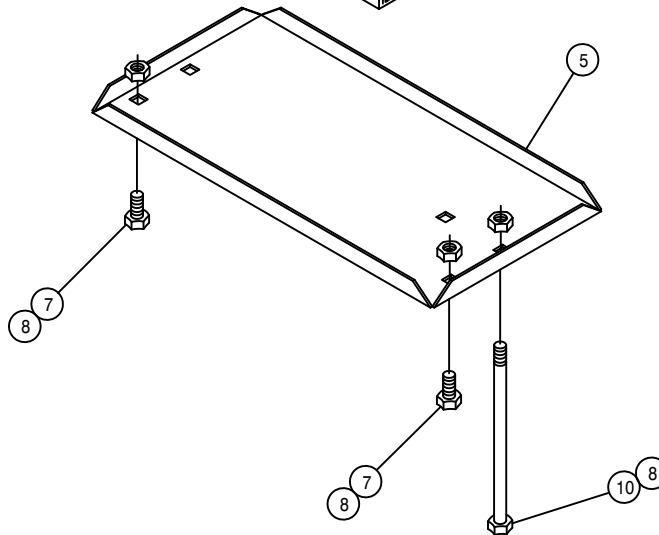
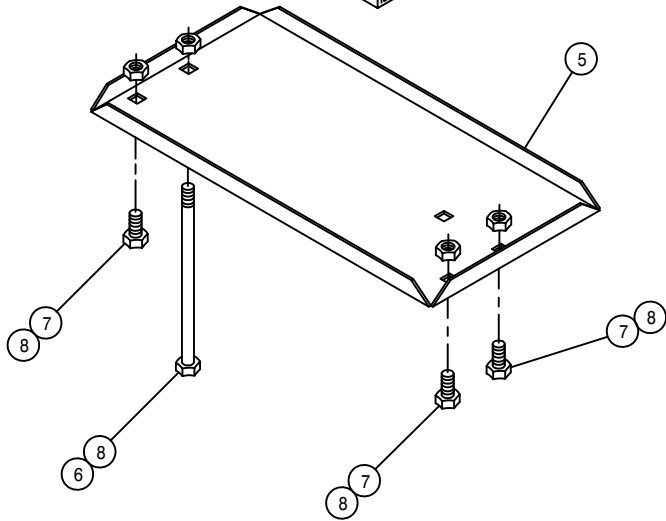
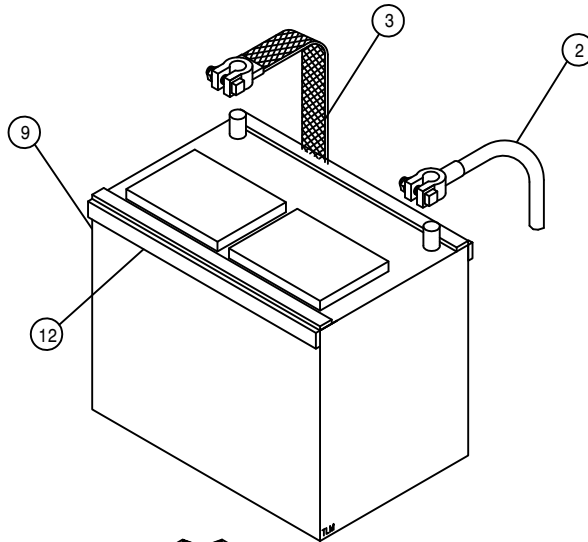
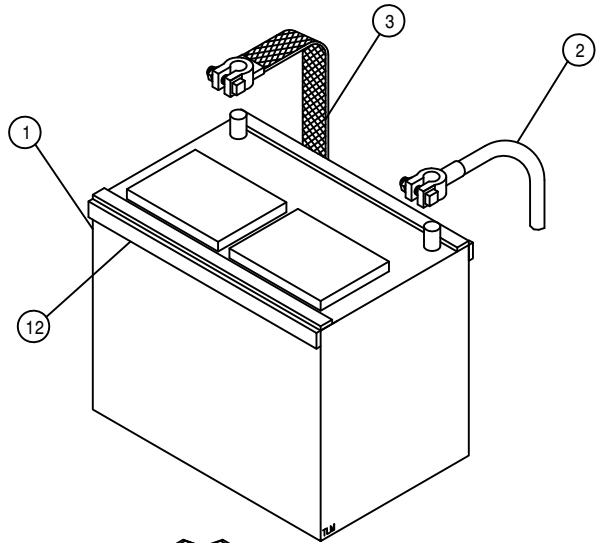
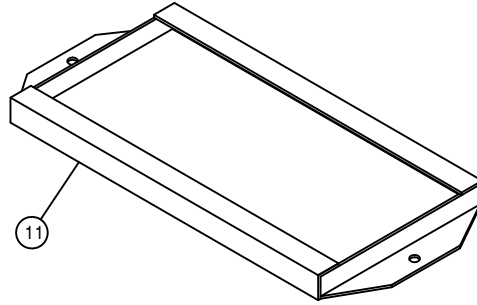
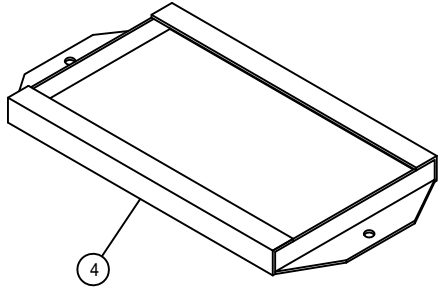

BATTERY BOX ASSEMBLY

DET.	QTY	PART NO.	DESCRIPTION
1	1	290013	BATT 12V 90AH LT WARRANTY
2	2	291128	BATTERY CABLE 48 IN
3	2	290111	GROUND STRAP
4	1	290212	BATT HOLD DOWN WLD CHRY
5	2	361149	BATTERY BOX 8300-8400 1981
6	2	901149	3/8UNC X 8 1/2 CARR BOLT
7	5	900128	3/8UNC X 3/4 HEX BOLT
8	9	914004	3/8UNC HEX STOVER NUT
9	1	291122	BATTERY,575 AMP 160 RES
10	2	901150	3/8UNC X 9 CARR BOLT
11	1	341322	BATTERY HOLD DOWN WLD 1981
12	8	193022	STICKERTITE 1/4 X 3/4

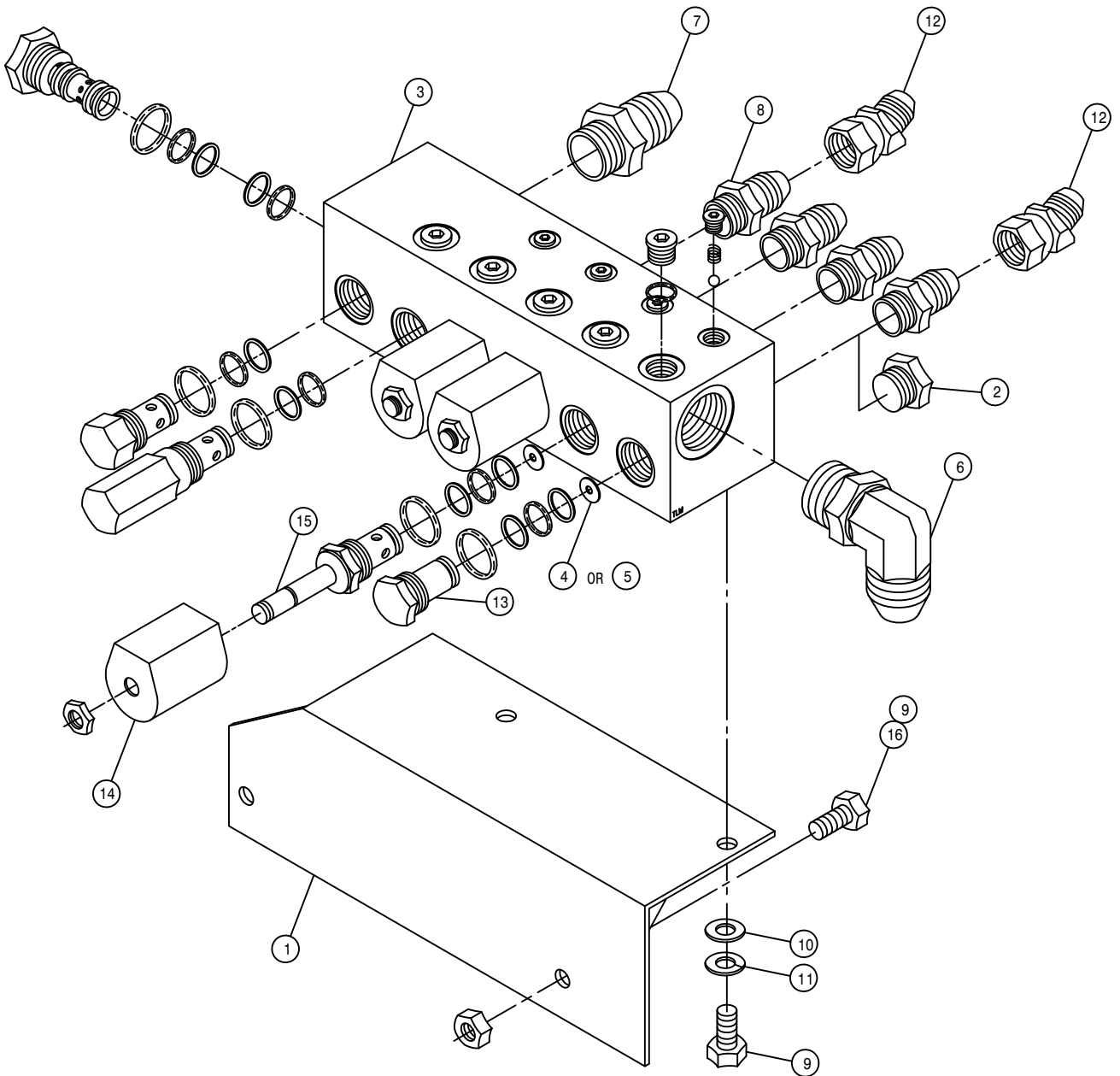

MOTOR CONTROL VALVE ASSEMBLY

DET.	QTY	PART NO.	DESCRIPTION
1	1	341846	MTR CTRL VLV MT WLD 200
2	1	610186	1 1/16MOR PLUG
3	1	610467	MODULAR MTR CONTROL ELECT VLV
4	4	610562	DISK .199 ORIFICE MOD CTRL
5	4	610478	DISK .182 ORIFICE MOD CTRL
6	1	618178	1 5/16MJIC-90-1 5/16MOR LBO
7	1	618186	1 5/16MJIC-1 5/16MOR ADPTR
8	4	618469	3/4MJIC-1 1/16MOR ADPTR
9	4	900128	3/8UNC X 3/4 HEX BOLT
10	2	920002	WASH FLAT 3/8 SAE
11	2	920502	LOCK WASH 3/8
12	2	618590	3/4MJIC-45-3/4FJIC SWIV LBO
13	1	610477	PLUG-10SERIES 2WAY MOD CTRL
14	4	610480	SOLENOID COIL FOR610476REPAIR
15	4	610481	SOLENOID VLV FOR 610476REPAIR
16	2	914004	3/8UNC HEX STOVER NUT

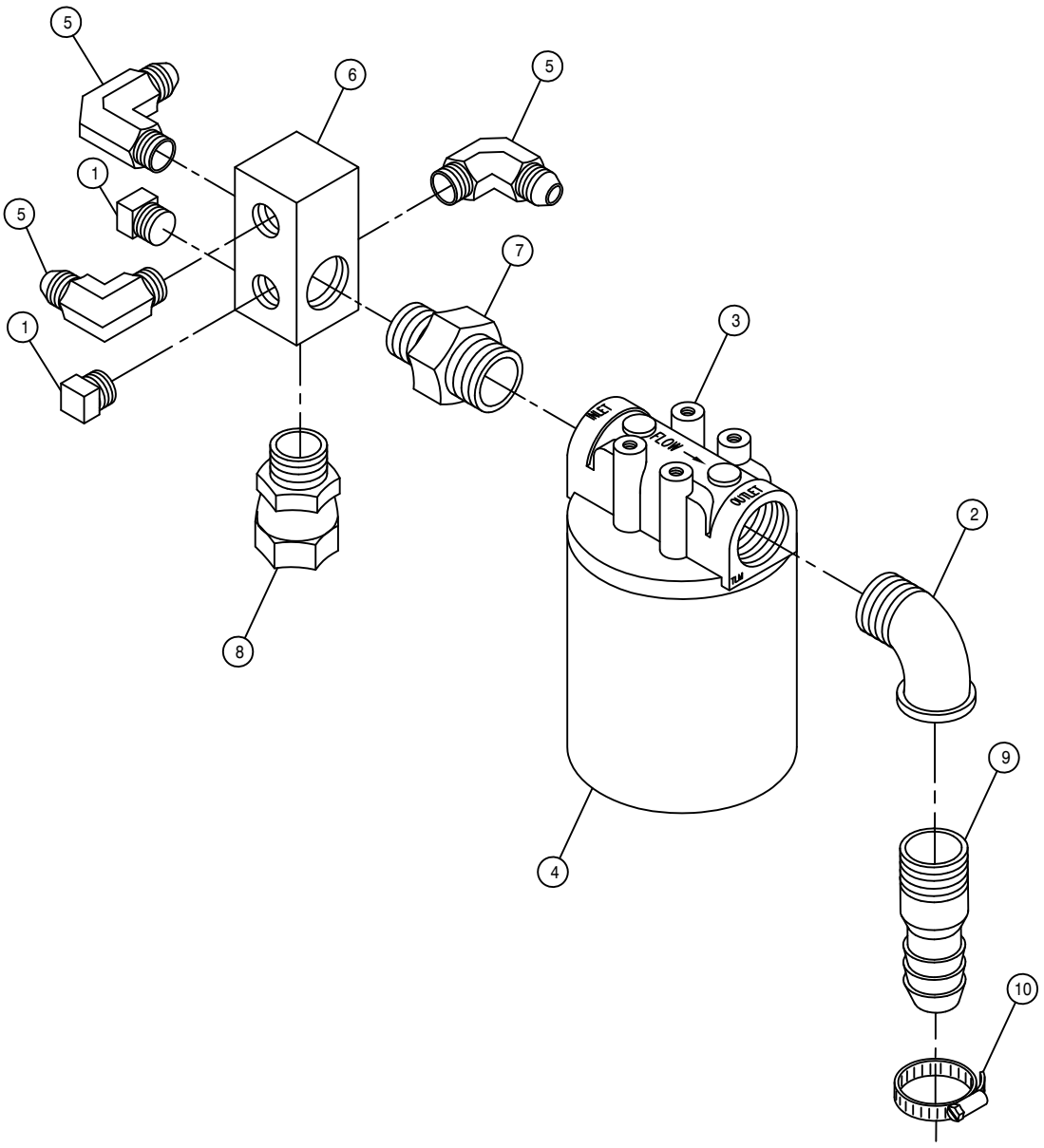

RETURN MANIFOLD FILTER ASSEMBLY

DET.	QTY	PART NO.	DESCRIPTION
1	2	503700	PIPE PLUG .50NPT SQ HD
2	1	506410	BLK PIPE ST EL 90DEG 1.25NPT
3	1	605601	GRESEN FILTER 10 MICRON 40GPM
4	1	605602	FILT ELEMENT 10MICRON 40GPM
5	3	611145	3/4MJIC-90-1/2MNPT LBO
6	1	614633	HYD MANIF 8200 86
7	1	618144	1 1/4-1MP HEX PIPE NIPPLE STL
8	1	618587	1 5/16FJIC SWIV-1MNPT
9	1	715660	HOSE BARB 1 1/4NPT X 1 1/4
10	1	520085	HOSE CLAMP NO 24 PLATED

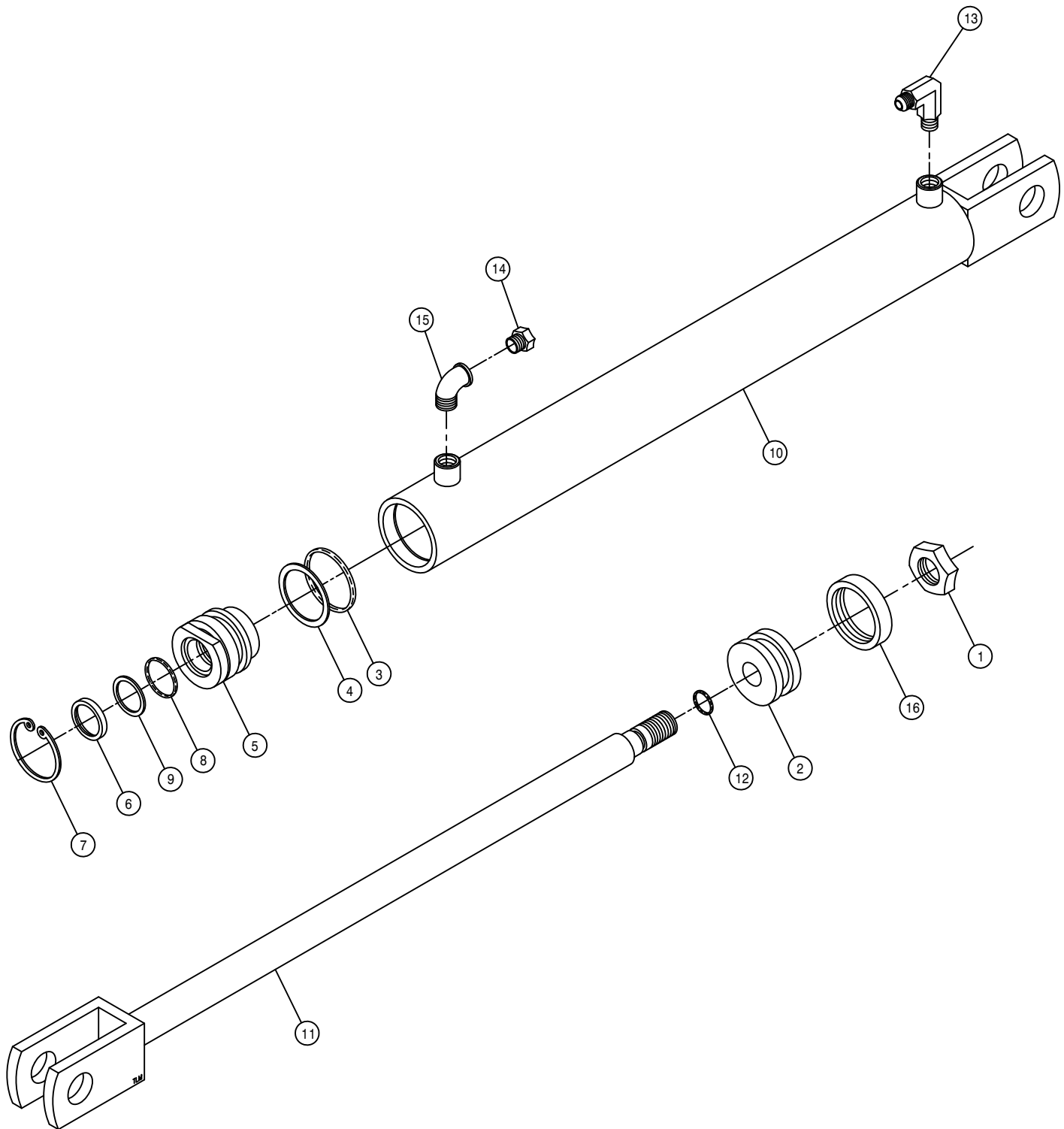

LIFT CYLINDER ASSEMBLY WITH T-TROL

DET.	QTY	PART NO.	DESCRIPTION
	1	472297	3/4UNF HEX STOVER NUT THIN
	2	620081	PISTON 2 X 1 ZAMAC ORING TYPE
	3	870326	BUNA ORING 1 5/8 X 2
	4	890326	BACKUP WASH 1 5/8 X 2 LEATH
	5	620082	GLAND 2 IN X 1 IN ZAMAC
	6	629003	WIPER 1 X 1 1/4 X 1/8
	7	629505	SNAP RING 2 IN INTRN
	8	870214	BUNA ORING 1 X 1 1/4
	9	890214	BACKUP WASH 1 X 1 1/4 HT2022
	10	620901	TUBE WLD CC2016 D00 SRG 180
	11	620905	SHAFT WLD CC2016 D00 SRG180
	12	870113	BUNA ORING 9/16 X 3/4
	13	611122	9/16MJIC-90-1/4MNPT LBO
	14	470114	BREATHER FILTER VENT, 1/4 NPT
	15	501452	ST EL 90DEG .25NPT, STEEL,PLT
	16	860326	CROWN SEAL, 2" PISTON, HYD

NOTE: 620900 - LIFT CYLINDER INCLUDES ITEMS 1-12.
620083 - SEAL KIT

4-6-8 ROW OUTRIGGER ASSEMBLY

DET. QTY PART NO. DESCRIPTION

1	1	438283	OUTRGR PIVOT PIN WLD 8200	86
2	1	438320	BUSH 1.00 OD X .531ID X.28LG	
3	1	470117	COTTER PIN 3/16 1 3/4 SQ CUT	
4	1	438307	RH 75IN OUTRGR WLD8200-850086	
5	1	438309	LH 75IN OUTRGR WLD8200-850086	
6	4	438324	75IN OUTRGR BRACE CLAMP	
7	1	438344	200 TOOL BAR WLD	89
8	1	438349	RH OUTRGR SUPP POST WLD200	89
9	1	438350	LH OUTRGR SUPP POST WLD200	89
10	1	438355	RH OUTRGR SUPP BRACE 200	89
11	1	438356	LH OUTRGR SUPP BRACE 200	89
12	1	438357	OUTRGR SUPP ROD WLD 200	89
13	1	438359	OUTRGR TIE BAR WLD 200	89
14	1	438362	RH OUTRGR CLAMP WLD 200	89
15	1	438363	LH OUTRGR CLAMP WLD 200	89
16	1	438390	OUTER STABILIZER TUBE WLD	90
17	1	438393	INNER STABILIZER TUBE WLD	90
18	1	438397	STABILIZER PIN MT WLD	90
19	1	438400	RH STABILIZER PIN MT WLD	90
20	1	438403	LH STABILIZER PIN MT WLD	90
21	1	438405	STABILIZER BALL MT WLD	90
22	1	438277	RH 32IN OUTRGR WLD8200-850086	
23	1	438282	LH 32IN OUTRGR WLD8200-850086	
24	1	483041	1/2 REGULAR FLAT WASH PLT	
25	1	611016	HAIR PIN #6	
26	2	900133	3/8UNC X 2 HEX BOLT	
27	16	900265	1/2UNC X 1 1/2 HEX BOLT	
28	1	900266	1/2UNC X 1 3/4 HEX BOLT	
29	2	900271	1/2UNC X 3 1/4 HEX BOLT	
30	3	900334	5/8UNC X 1 3/4 HEX BOLT	
31	1	900336	5/8UNC X 2 1/2 HEX BOLT	
32	1	900352	5/8UNC X 2 1/4 HEX BOLT	
33	4	910012	3/4UNC HEX NUT	
34	2	914004	3/8UNC HEX STOVER NUT	
35	20	914008	1/2UNC HEX STOVER NUT	
36	5	914010	5/8UNC HEX STOVER NUT	
37	1	900264	1/2UNC X 1 1/4 HEX BOLT	
38	1	438497	RH 82" OUTRGR WLD, 204	94
39	1	438498	LH 82" OUTRGR WLD, 204	94

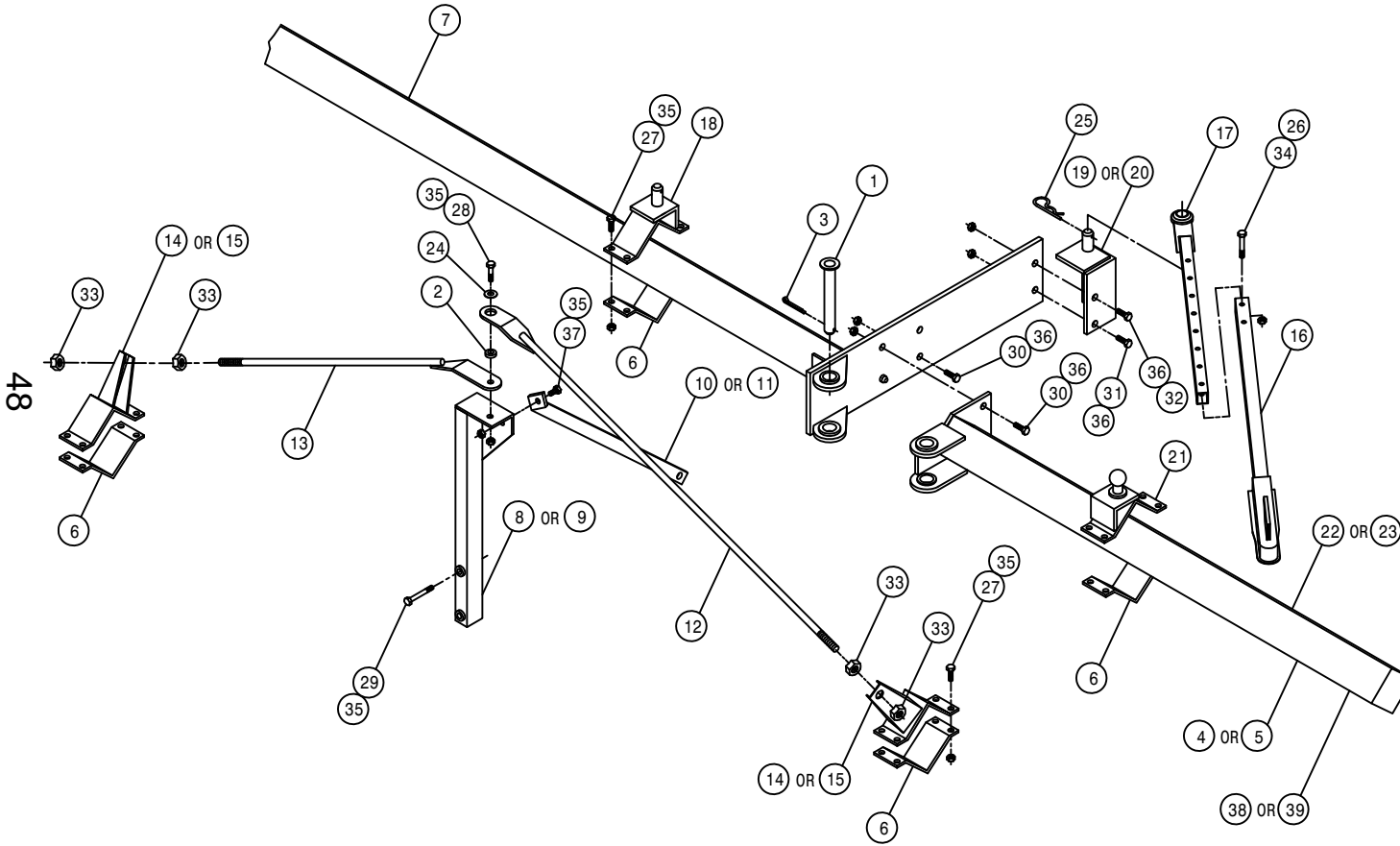

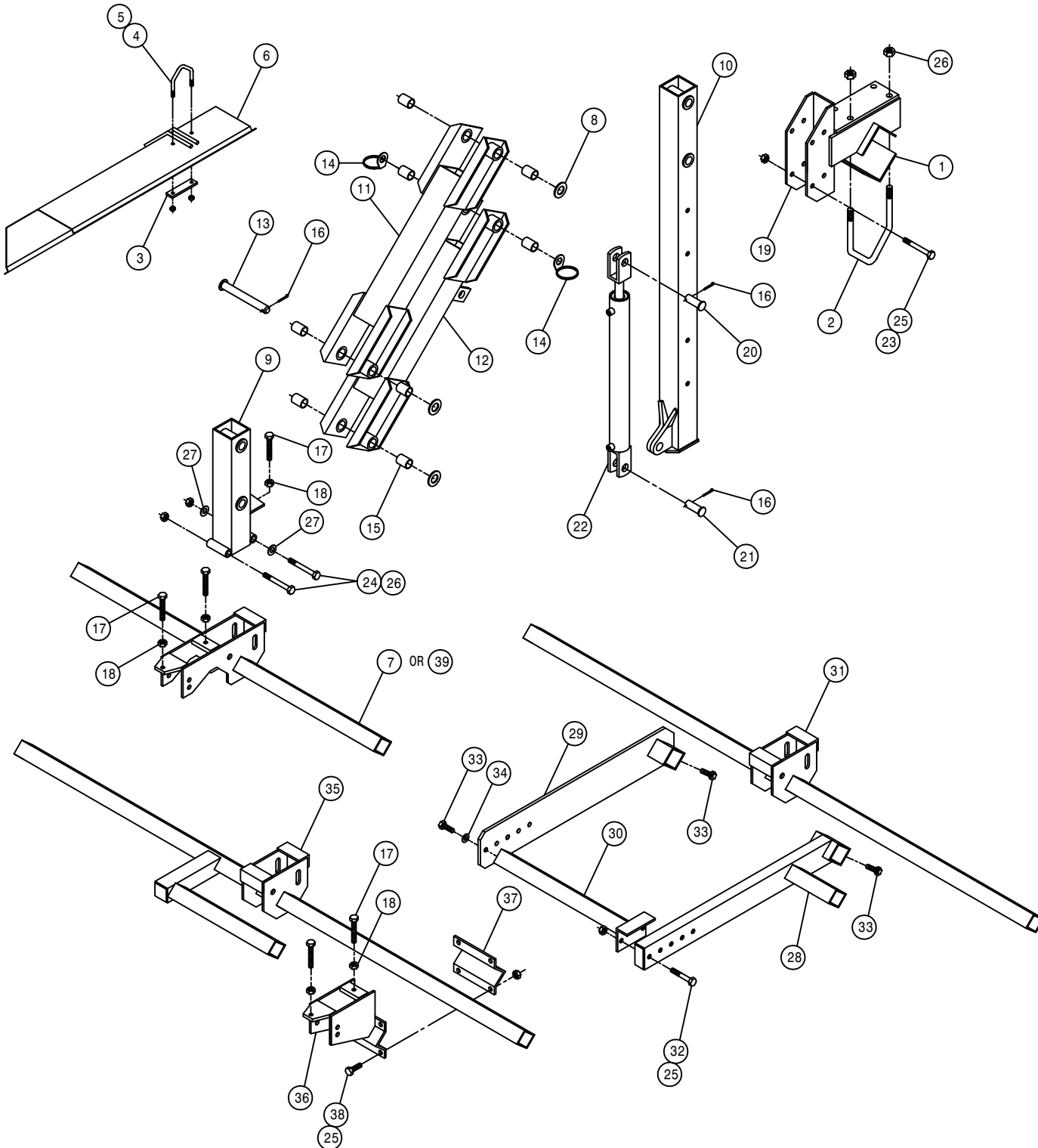

4-6-8 ROW DETASSLER LIFT ASSEMBLY

DET.	QTY	PART NO.	DESCRIPTION	
1	1	438292	TOOL BAR V-PLT WLD 8200	86
2	2	438293	5/8UNC X 6 1/4 CTR UBOLT TRI	
3	1	410051	U BOLT CLAMP CENTER DEFLECTOR	
4	1	410052	5/16UNC X 3 CTR UBOLT TRIBEND	
5	2	914002	5/16UNC HEX STOVER NUT	
6	1	410048	CENTER DEFLECTOR WLD 473	
7	1	438194	TOOL BAR WLD DETAS 4-6R	83
8	3	920008	1" SAE FLAT WASHER, PLATED	
9	1	438177	TOOL BAR MT WLD DETAS 83	
10	1	438184	HOIST COL WLD DETAS LIFT 83	
11	1	438294	UPPER LIFT ARM WLD 8200	86
12	1	438297	LWR LIFT ARM WLD 8200	86
13	4	438300	LIFT ARM PIVOT PIN WLD8200	86
14	2	438302	HOSE SUPPORT RING WLD W/WASHER	
15	8	121025	JOURNAL BRG FOR 1IN SHFT1.5LG	
16	6	470162	COTTER PIN 3/16 X 1 1/2 SQCUT	
17	5	900538	1/2UNC X 3 1/2 HEX BOLT FULL	
18	5	910008	1/2UNC HEX NUT	
19	1	438367	HOIST COL MT BRKT WLD 200	90
20	1	472012	PICKER PIN 1 X 3 1/4	
21	1	472206	PICKER PIN 1 DIA X 2 1/4	
22	1	620900	CYL ASSY CC2016 D00 SRG 180	
23	4	900275	1/2UNC X 4 1/2 HEX BOLT	
24	2	900343	5/8UNC X 4 1/2 HEX BOLT	
25	10	914008	1/2UNC HEX STOVER NUT	
26	6	914010	5/8UNC HEX STOVER NUT	
27	2	920005	5/8 FLAT WASH SAE	
28	1	438209	8R PLR OUTER MT ARM WLD 8200	
29	1	438214	8R PLR INNER MT ARM WLD 8200	
30	1	438216	8R PLR MT WLD 8200	83
31	1	438220	8R TIRE PLR TOOL BAR WLD 83	
32	2	900268	1/2UNC X 2 1/2 HEX BOLT	
33	3	900263	1/2UNC X 1 HEX BOLT	
34	1	920504	LOCK WASH 1/2	
35	1	438201	TOOL BAR WLD 8R DETAS 83	
36	1	438199	T-TROL MT WLD 8R DETAS 83	
37	1	410016	RLR HANGER V 473	
38	4	900265	1/2UNC X 1 1/2 HEX BOLT	
39	1	438500	TOOL BAR WLD, 54"	94

NOTE: ITEMS 3,4,5, AND 6 ARE USED WITH THE ROLLER PULLER OPTION.

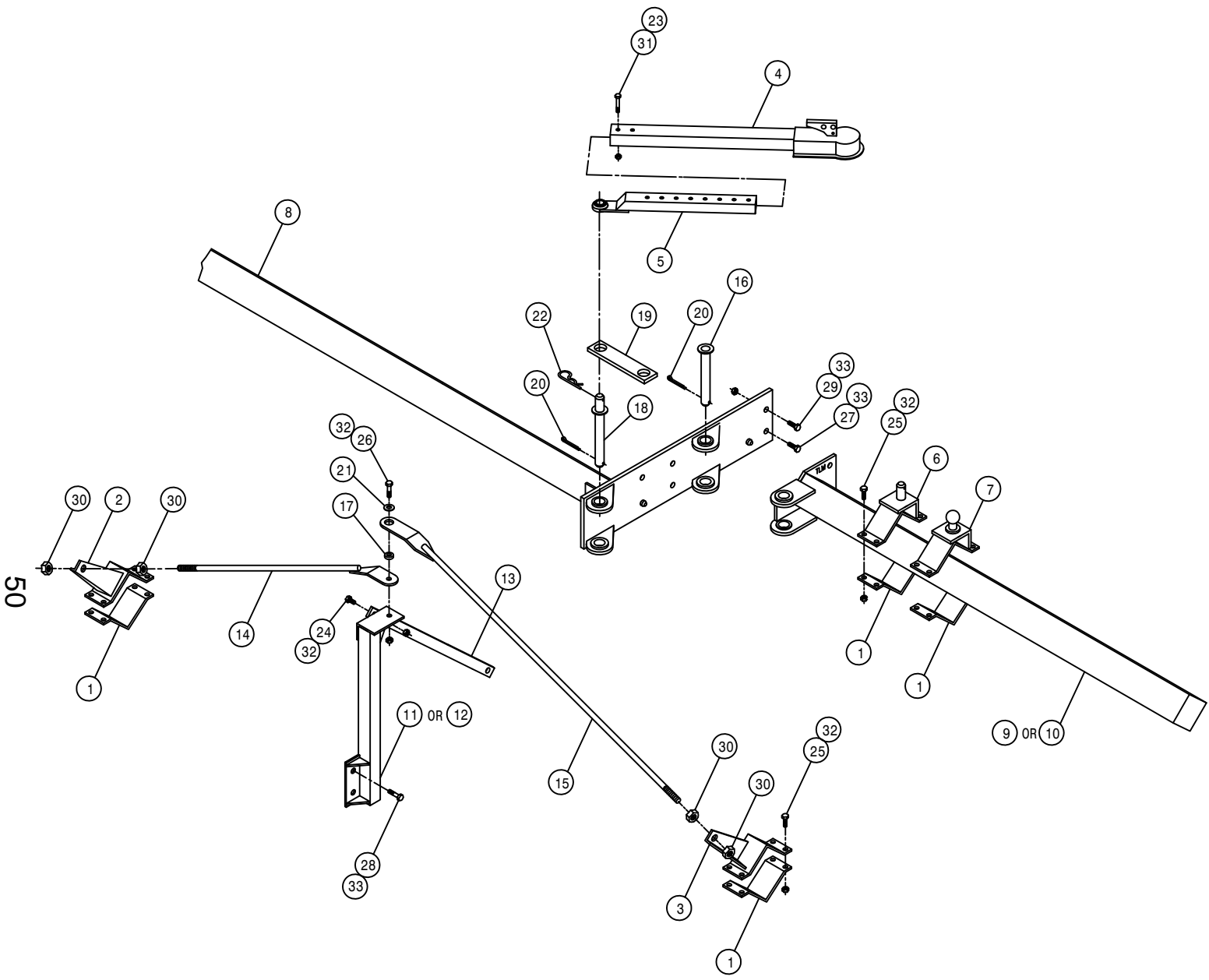

10-12 ROW OUTRIGGER ASSEMBLY

DET.	QTY	PART NO.	DESCRIPTION
1	4	438324	75IN OUTGR BRACE CLAMP
2	1	438362	RH OUTGR CLAMP WLD 200 89
3	1	438363	LH OUTGR CLAMP WLD 200 89
4	1	438390	OUTER STABILIZER TUBE WLD 90
5	1	438393	INNER STABILIZER TUBE WLD 90
6	1	438397	STABILIZER PIN MT WLD 90
7	1	438405	STABILIZER BALL MT WLD 90
8	1	438457	200 TOOL BAR WLD 10-12R 92
9	1	438458	RH 101IN OUTGR WLD 10-12R 92
10	1	438459	LH 101IN OUTGR WLD 10-12R 92
11	1	438461	RH OUTGR SUPP POST WLD10-12R
12	1	438462	LH OUTGR SUPP POST WLD10-12R
13	1	438468	OUTGR SUPP BRACE 200 10-12R
14	1	438469	OUTGR TIE BAR WLD 200 10-12R
15	1	438471	OUTGR SUPP ROD WLD 10-12R
16	1	438283	OUTGR PIVOT PIN WLD 8200 86
17	1	438320	BUSH 1.00 OD X .531ID X.28LG
18	1	438474	STABILIZER MT PIN WLD 10-12R
19	1	438476	OUTGR TRANSPORT BAR 10-12R
20	2	470117	COTTER PIN 3/16 1 3/4 SQ CUT
21	1	483041	1/2 REGULAR FLAT WASH PLT
22	2	611016	HAIR PIN #6
23	2	900133	3/8UNC X 2 HEX BOLT
24	1	900264	1/2UNC X 1 1/4 HEX BOLT
25	16	900265	1/2UNC X 1 1/2 HEX BOLT
26	1	900266	1/2UNC X 1 3/4 HEX BOLT
27	1	900334	5/8UNC X 1 3/4 HEX BOLT
28	2	900336	5/8UNC X 2 1/2 HEX BOLT
29	1	900352	5/8UNC X 2 1/4 HEX BOLT
30	4	910012	3/4UNC HEX NUT
31	2	914004	3/8UNC HEX STOVER NUT
32	18	914008	1/2UNC HEX STOVER NUT
33	4	914010	5/8UNC HEX STOVER NUT

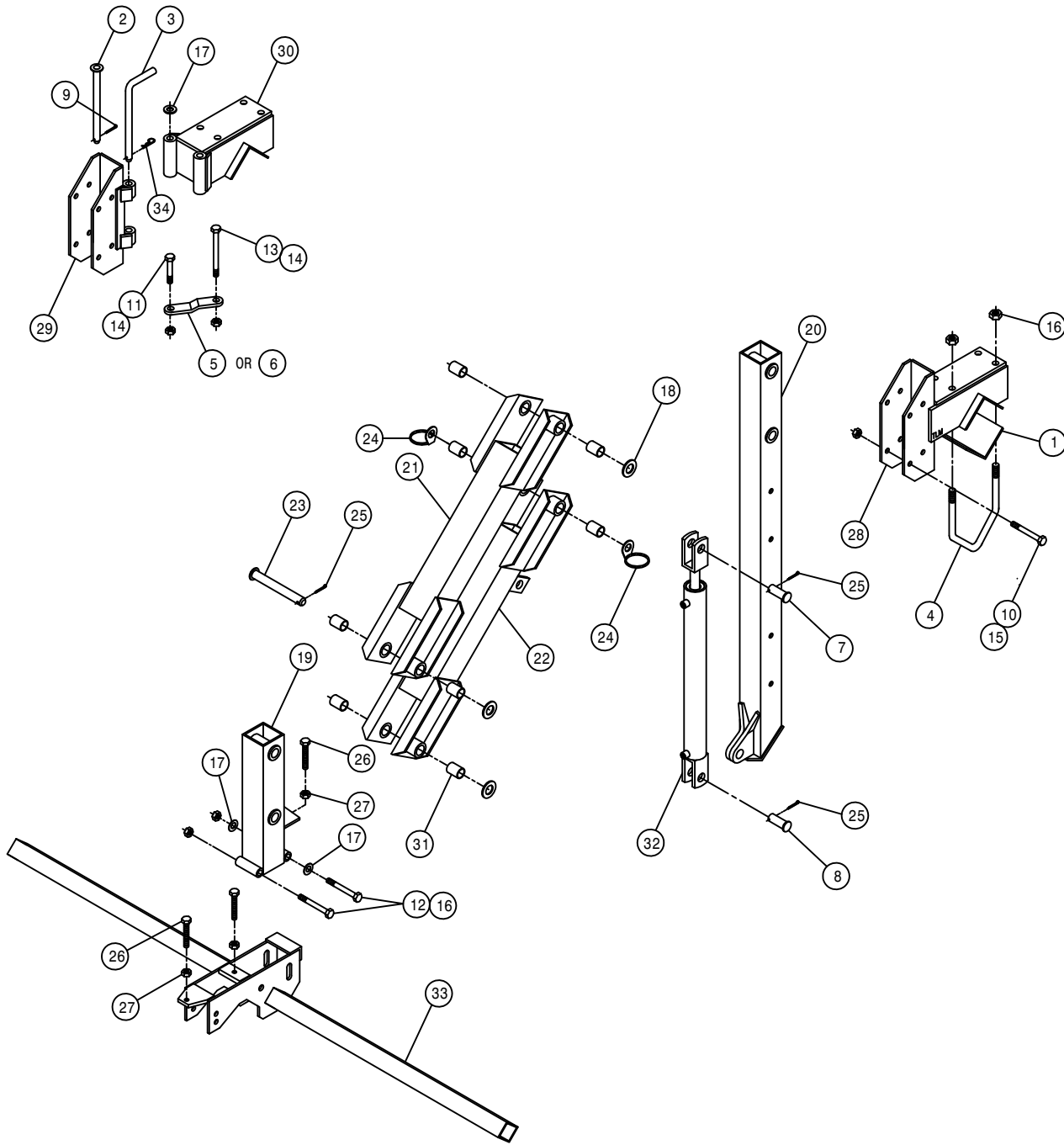

12 ROW DETASSLER LIFT ASSEMBLY

DET. QTY PART NO. DESCRIPTION

1	1	438292	TOOL BAR V-PLT WLD 8200	86
2	1	438489	HINGED HOIST COL PIV PIN WLD	
3	1	438491	HINGED HOIST COL KPR PIN	
4	2	438293	5/8UNC X 6 1/4 CTR BOLT TRI	
5	1	438492	SHORT HINGED COL MT LATCH	
6	1	438493	LONG HINGED COL MT LATCH	
7	1	472012	PICKER PIN 1 X 3 1/4	
8	1	472206	PICKER PIN 1 DIA X 2 1/4	
9	1	390984	COTTER PIN 1/8 X 1 1/4	
10	4	900275	1/2UNC X 4 1/2 HEX BOLT	
11	1	900337	5/8UNC X 2 3/4 HEX BOLT	
12	2	900343	5/8UNC X 4 1/2 HEX BOLT	
13	1	900346	5/8UNC X 6 HEX BOLT	
14	2	910010	5/8UNC HEX NUT	
15	4	914008	1/2UNC HEX STOVER NUT	
16	6	914010	5/8UNC HEX STOVER NUT	
17	3	920005	5/8 FLAT WASH SAE	
18	3	920008	1" SAE FLAT WASHER, PLATED	
19	1	438177	TOOL BAR MT WLD DETAS 83	
20	1	438184	HOIST COL WLD DETAS LIFT 83	
21	1	438294	UPPER LIFT ARM WLD 8200	86
22	1	438297	LWR LIFT ARM WLD 8200	86
23	4	438300	LIFT ARM PIVOT PIN WLD8200	86
24	2	438302	HOSE SUPPORT RING WLD W/WASHER	
25	6	470162	COTTER PIN 3/16 X 1 1/2 SQ CUT	
26	2	900538	1/2UNC X 3 1/2 HEX BOLT FULL	
27	2	910008	1/2UNC HEX NUT	
28	1	438367	HOIST COL MT BRKT WLD 200 90	
29	1	438481	HINGED HOIST COL MT WLD, FRT	
30	1	438482	HINGED HOIST COL MT WLD, REAR	
31	8	121025	JOURNAL BRG FOR 1IN SHFT1.5LG	
32	1	620900	CYL ASSY CC2016 D00 SRG 180	
33	1	438478	TOOL BAR WLD 10-12R DETASSLR	
34	1	470120	HAIR PIN 3/32 DIA. WIRE	

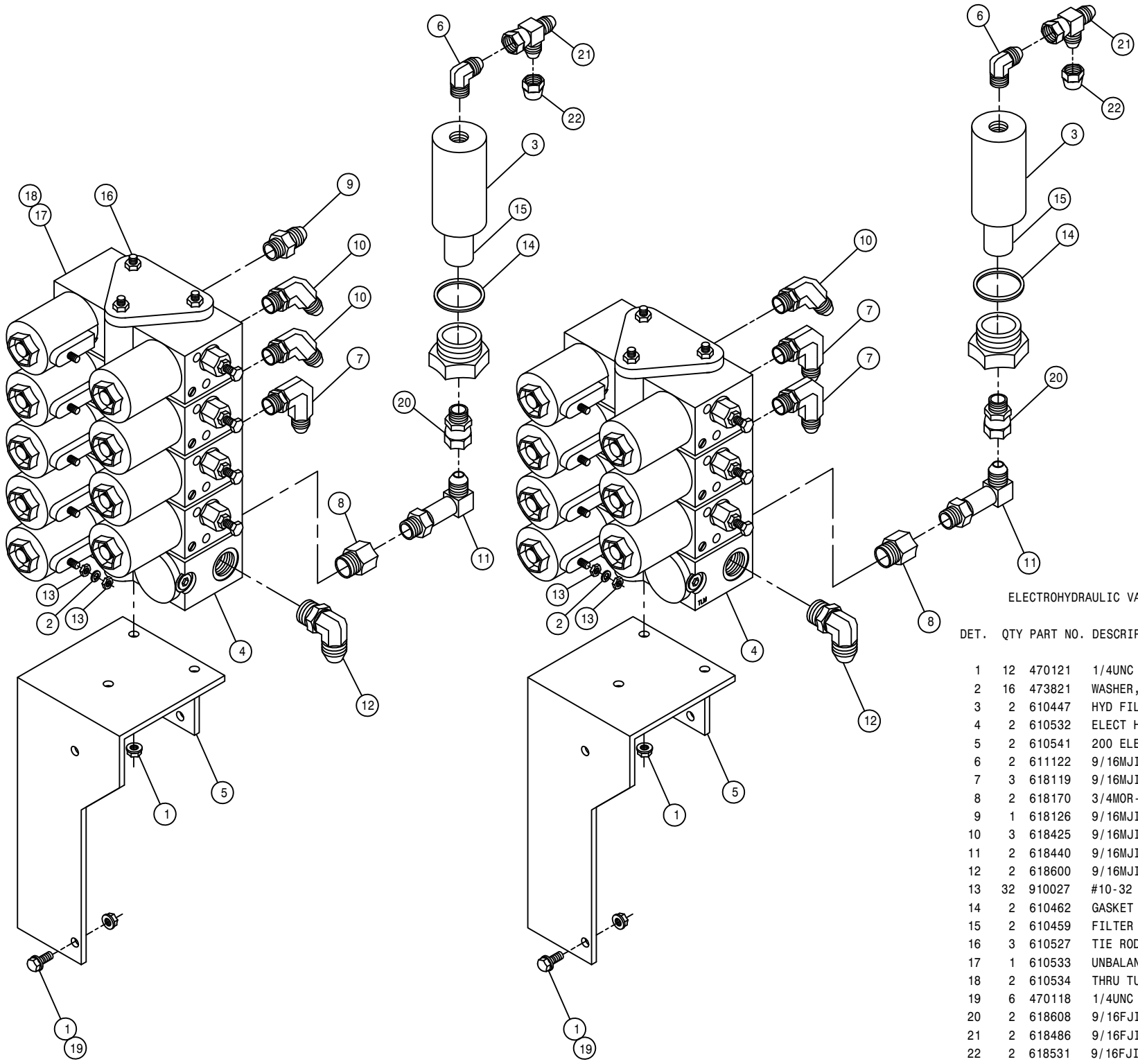

ELECTROHYDRAULIC VALVE ASSEMBLY

DET.	QTY	PART NO.	DESCRIPTION
1	12	470121	1/4UNC HEX FLANGED LOCK NUT
2	16	473821	WASHER, INT TOOTH #10
3	2	610447	HYD FILTER, INLINE 1/4FNPT 90M
4	2	610532	ELECT HYD STACK VLV W/ADJ 89
5	2	610541	200 ELECT T-TROL VLV MT WLD89
6	2	611122	9/16MJIC-90-1/4MNPT LBO
7	3	618119	9/16MJIC-90-9/16MOR LBO
8	2	618170	3/4MOR-9/16FOR ADPTR
9	1	618126	9/16MJIC-9/16MOR ADPTR
10	3	618425	9/16MJIC-45-9/16MOR LBO
11	2	618440	9/16MJIC-90-9/16MOR EX LG LBO
12	2	618600	9/16MJIC-90-7/8MOR LBO
13	32	910027	#10-32 HEX NUT
14	2	610462	GASKET FOR 610447 ARROW FILT
15	2	610459	FILTER ELEMENT FOR 610447 90M
16	3	610527	TIE ROD- 4 SECTION ELECT VLV
17	1	610533	UNBALANCED LOAD VALVE 89
18	2	610534	THRU TUBE ASSY ELEC VLV 89
19	6	470118	1/4UNC X 3/4 FLANGED HEX BOLT
20	2	618608	9/16FJIC SWIV-1/4MNPT
21	2	618486	9/16FJIC SW RUN TEE-9/16MJIC
22	2	618531	9/16FJIC CAP NUT

53

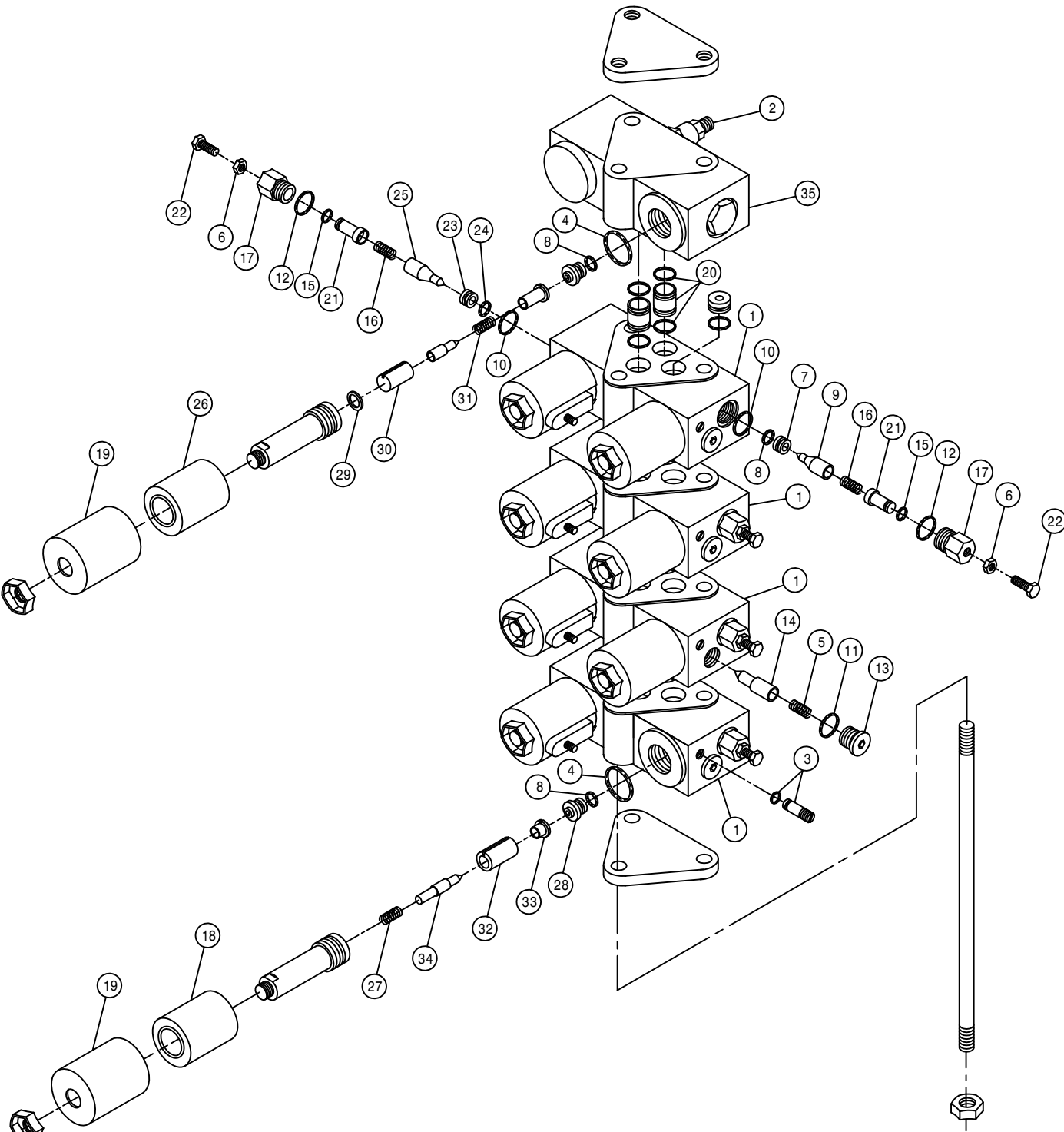

ELECTROHYDRAULIC VALVE

DET.	QTY	PART NO.	DESCRIPTION	
1	4	610533	UNBALANCED LOAD VALVE	89
2	1	610551	R.V. CARTRIDGE FOR 610532	90
3	8	610267	SEAL PLUG ASSY FOR 610257	
4	9	871019	ORING, 13/16 X 15/16 NEO 90D	
5	4	610491	SPRING AM-501-3-035 FOR610485	
6	8	910000	1/4UNC HEX NUT	
7	4	610488	ORIFICE PRESSED IN BLACK	
8	13	871010	ORING 1/4 X 3/8 VITON 90D	
9	4	610129	POPPET,ELECT VALVE,UNBAL LOAD	
10	8	870013	ORING, 7/16 X 9/16 NEO 70D	
11	4	871904	ORING, .351 X .072CS NEO 90D	
12	8	871906	ORING, .468ID X .078CS NEO 90D	
13	4	610130	PLUG, SAE4,ELECT VALVE,UNBAL	
14	4	610489	CHECK VLV POPPET	
15	8	871008	O-RING 3/16 X 5/16 90D	
16	8	610492	SPRING AM-570-3-126 FOR610485	
17	8	610453	VLV CAP	
18	8	610493	COIL FOR 610485	86
19	9	610113	COVER, ELECT VALVE, NON ADJ	
20	8	610534	THRU TUBE ASSY ELEC VLV	89
21	8	610452	ADJ VLV STOP	
22	8	900003	1/4UNC X 1" HEX BOLT	
23	4	610494	ORIFICE FOR 610485	
24	4	871056	O-RING	90D
25	4	610495	POPPET FOR 610485AM-570-3-654	
26	1	610076	COIL, ELECT STACK VALVE	
27	8	610127	SPRING,ELECT VALVE,UNBAL LOAD	
28	8	610108	ORIFICE 040, ELECT VALVE	
29	1	610084	WASHER, ELECT-HYD VALVE	
30	1	610112	ARMATURE, ELECT VALVE	
31	1	610110	SPRING, ELECT VALVE, NON ADJ	
32	8	610126	ARMATURE, ELECT VALVE, UNBAL	
33	8	610133	POLE PIECE,ELECT VALVE, UNBAL	
34	8	610490	POPPET FOR 610485AM-501-3-033	
35	1	610679	UNLOAD RELIEF VALVE	

150053

ROLLER PULLER HEAD ASSEMBLY

DET. QTY PART NO. DESCRIPTION

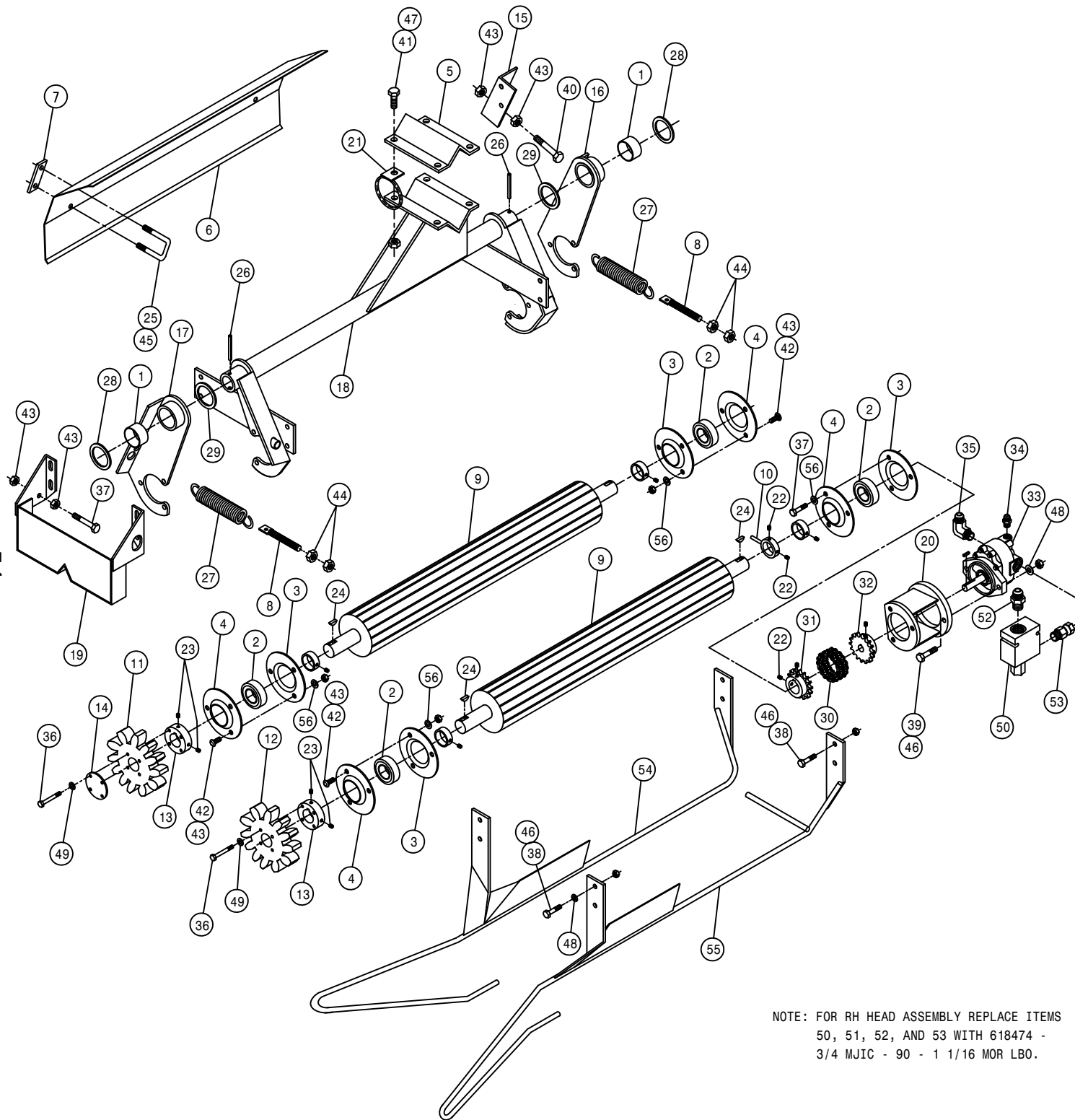

1	2	120913	BUSH HALF 1.8750D X 1LG
2	4	123024	BGR 1 1/4 BORE SPHERICL RELUB
3	4	123026	FLANGETT 1 1/4 RELUBE
4	4	123035	FLANGETT 1 1/4 180 DEG ZERK
5	1	410016	RLR HANGER V 473
6	1	410028	RLR TASSLE DEFLECTOR
7	2	410029	U BOLT CLAMP 473
8	2	410032	SPRING HOOK BOLT WLD 473
9	2	410060	RUBBER ROLLER, GROOVED 78
10	1	410063	TRASH FINGER WLD 473 1978
11	1	410065	GEAR PLASTIC RLR 473 78
12	1	410066	GEAR, ALUM RLR 473 78
13	2	410067	HUB, RLR GEAR 473 1978
14	1	410069	WASHER, PLASTIC GEAR, ROLLER
15	1	410078	STOP RLR REAR
16	1	410084	BRG MT WLD, RLR
17	1	410090	BRG MT WLD FT
18	1	410120	RLR PLR TUBE WLD 83
19	1	410145	RLR SPRKT SHLD WLD
20	1	410166	CES MTR MT WLD 8200 RLR 89
21	1	438303	HOSE KPR RING WLD W/TAB
22	3	470054	SET SCREW 5/16X 1/4 AL HD CUP
23	4	470156	1/4-20 X 3/4 SQHD SET SCR CUP
24	3	472000	91 WOODRUFF KEY
25	2	472264	5/16UNC-1 3/4ID-2 15/16 UBOLT
26	2	473945	ROLL PIN, 1/4DIA X 2 1/2 LONG
27	2	482006	SPRING FOR 473 ROLLER4IN LONG
28	2	483008	MACH WASH 1 13/16ID 2 3/8OD
29	2	483009	MACH WASH 1 13/16ID X 2 3/8OD
30	1	492084	CHAIN FOR 492083 4016
31	1	492091	CHAIN CPLR 1 1/4 BORE .25 KWY
32	1	492092	CHAIN CPLR 5/8 BORE 5/32 KWY
33	1	610510	CESSNA GEAR MOTOR 1.48CI
34	1	611121	9/16MJIC-1/4MNPT ADPTR
35	1	618474	3/4MJIC-90-1 1/16MOR LBO
36	8	900006	1/4UNC X 1 3/4 HEX BOLT
37	4	900129	3/8UNC X 1 HEX BOLT
38	8	900130	3/8UNC X 1 1/4 HEX BOLT
39	2	900131	3/8UNC X 1 1/2 HEX BOLT
40	1	900134	3/8UNC X 2 1/2 HEX BOLT
41	4	900265	1/2UNC X 1 1/2 HEX BOLT
42	9	901129	3/8UNC X 1 CARR BOLT
43	13	910004	NUT, HEX, 3/8UNC GRS PLT
44	4	910008	1/2 UNC HEX NUT
45	4	914002	5/16 UNC STOVER NUT
46	10	914004	3/8 UNC STOVER NUT
47	4	914008	1/2 UNC STOVER NUT
48	6	920002	WASH FLAT 3/8 SAE
49	8	920500	LOCK WASH 1/4
50	1	610528	PRESS COMP FIXED FLO REG 11G
51	1	618248	1 1/16MJIC-90-1 1/16MOR LBO
52	1	618469	3/4MJIC-1 1/16MOR ADPTR
53	1	618578	1 1/16FJIC SWIV-1 1/16MOR
54	1	410153	RH STALK GUIDE WLD 8200 RLR86
55	1	410155	LF STALK GUIDE WLD 8200 RLR86
56	12	920502	3/8 LOCK WASHER

NOTE: FOR RH HEAD ASSEMBLY REPLACE ITEMS
50, 51, 52, AND 53 WITH 618474 -
3/4 MJIC - 90 - 1 1/16 MOR LBO.

54

150054

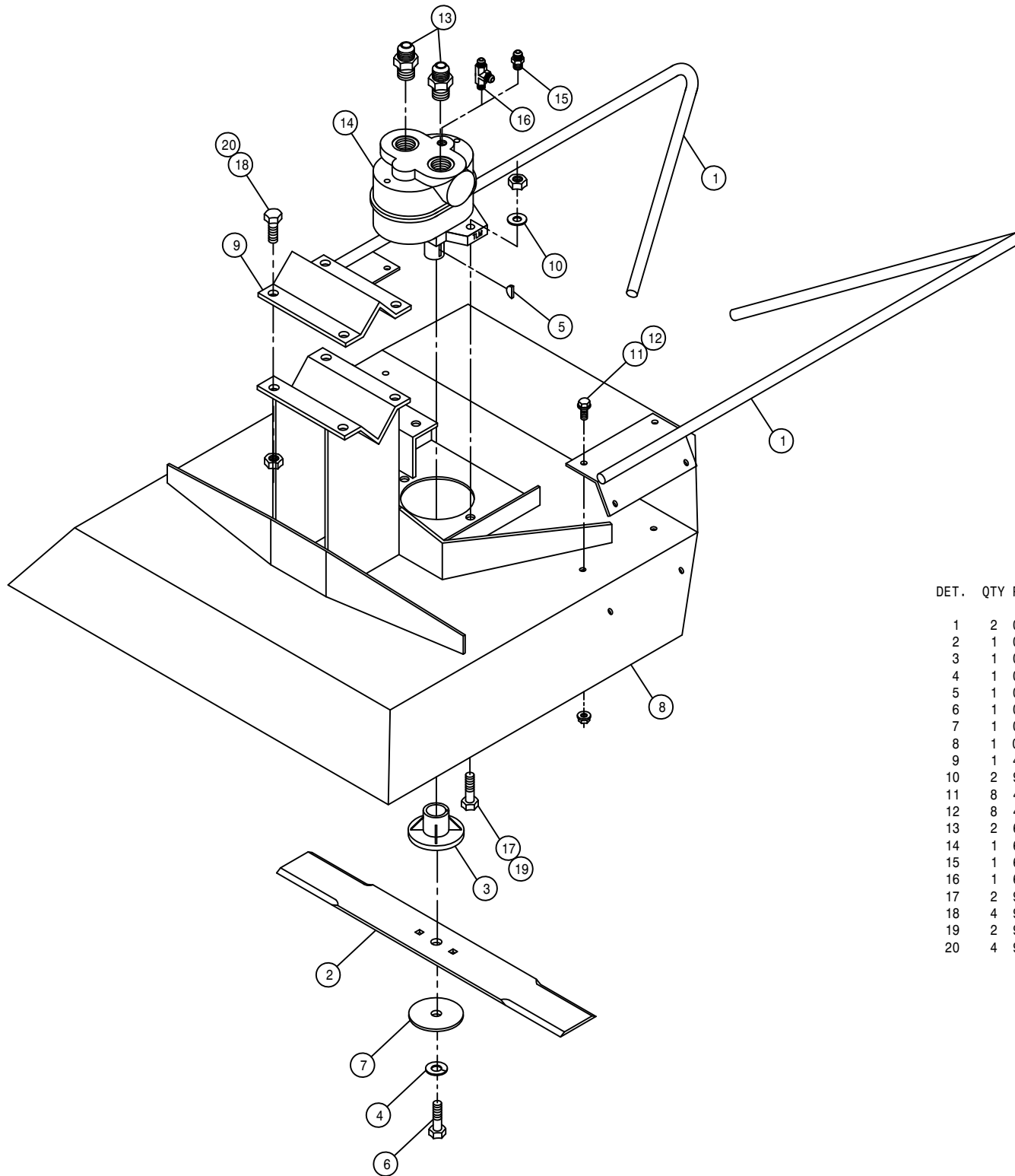

CUTTER HEAD ASSEMBLY

DET. QTY PART NO. DESCRIPTION

1	2	002215	CUTR STALK GUIDE WLD 8200	85
2	1	002103	CUTR BLADE 18 IN	
3	1	002104	CLUTCH BODY BLADE	
4	1	002105	STEEL LOCK WASH CUTR BLADE	
5	1	002106	WOODRUFF KEY #6 .156 X .625	
6	1	002107	3/8UNF X 1 1/2 HEX BOLT CUTR	
7	1	002108	STEEL WASHER CUTTER BLADE	
8	1	002210	CUTR TOP WLD 8200	85
9	1	410016	RLR HANGER V 473	
10	2	920002	3/8 SAE FLAT WASHER	
11	8	470118	1/4UNC X 3/4 FLANGE HEX BOLT	
12	8	470121	1/4UNC HEX FLANGE LOCK NUT	
13	2	611125	3/4MJIC-3/4MOR ADPTR	
14	1	610590	SUB>610755:BARNES HYD MOTOR	
15	1	618530	9/16MJIC-1/8MNPT ADPTR	
16	1	618546	1/8MNPT RUN TEE-9/16MJIC	
17	2	900130	3/8UNC X 1 1/4 HEX BOLT	
18	4	900265	1/2UNC X 1 1/2 HEX BOLT	
19	2	914004	3/8UNC HEX STOVER NUT	
20	4	914008	1/2UNC HEX STOVER NUT	

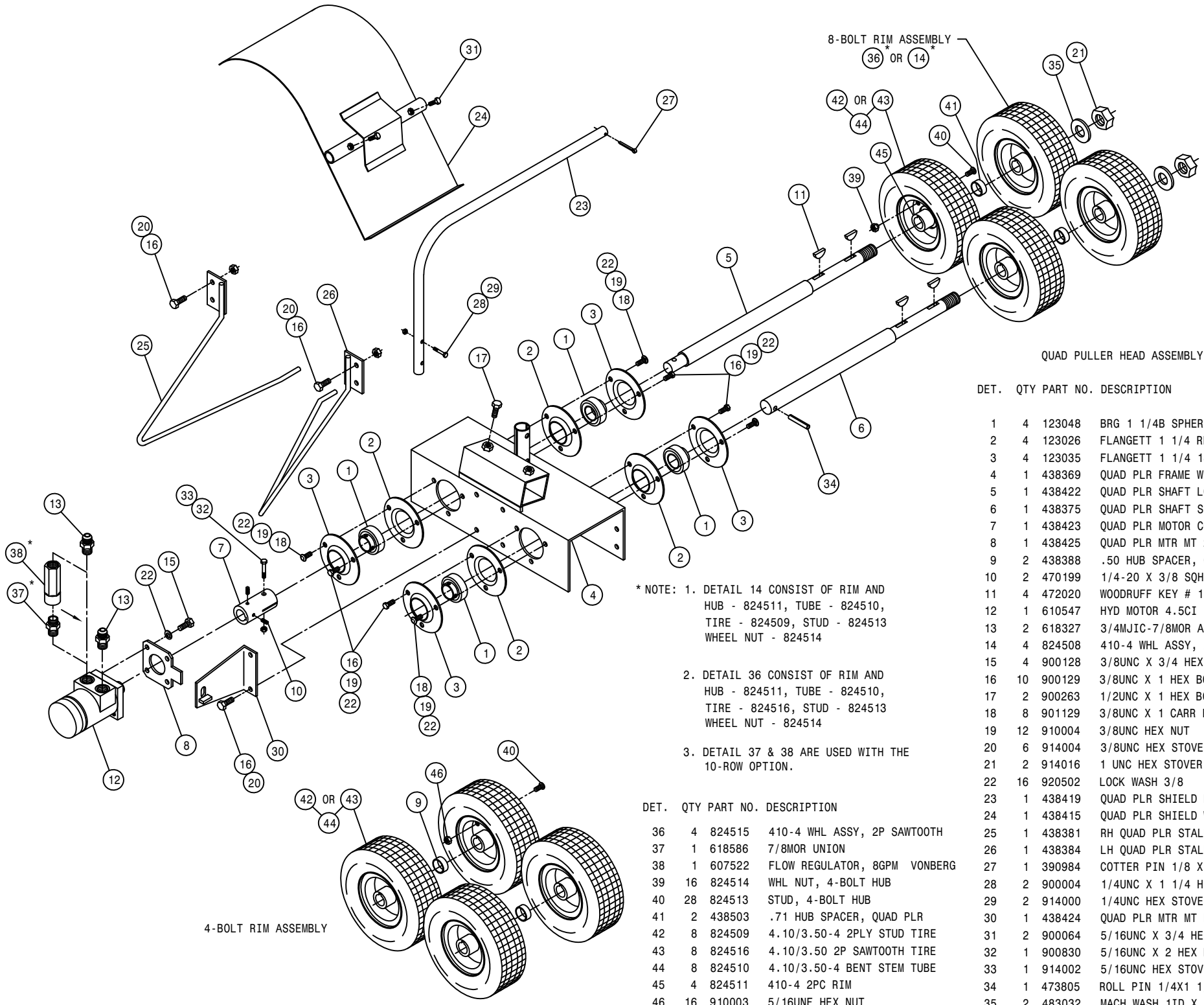

QUAD PULLER HEAD ASSEMBLY

DET.	QTY	PART NO.	DESCRIPTION
1	4	123048	BRG 1 1/4B SPHER RELUB SCRLOC
2	4	123026	FLANGETT 1 1/4 RELUBE
3	4	123035	FLANGETT 1 1/4 180 DEG ZERK
4	1	438369	QUAD PLR FRAME WLD 200 90
5	1	438422	QUAD PLR SHAFT LONG 200 91
6	1	438375	QUAD PLR SHAFT SHORT 200 90
7	1	438423	QUAD PLR MOTOR COUPLER 200 91
8	1	438425	QUAD PLR MTR MT 200 91
9	2	438388	.50 HUB SPACER, QUAD PLR
10	2	470199	1/4-20 X 3/8 SQHD CUP SET SCR
11	4	472020	WOODRUFF KEY # 18 1/4 X 1 1/8
12	1	610547	HYD MOTOR 4.5CI 1IN SHFT
13	2	618327	3/4MJIC-7/8MOR ADPTR
14	4	824508	410-4 WHL ASSY, 2P STUD
15	4	900128	3/8UNC X 3/4 HEX BOLT
16	10	900129	3/8UNC X 1 HEX BOLT
17	2	900263	1/2UNC X 1 HEX BOLT
18	8	901129	3/8UNC X 1 CARR BOLT
19	12	910004	3/8UNC HEX NUT
20	6	914004	3/8UNC HEX STOVER NUT
21	2	914016	1 UNC HEX STOVER NUT
22	16	920502	LOCK WASH 3/8
23	1	438419	QUAD PLR SHIELD MT TUBE 91
24	1	438415	QUAD PLR SHIELD WLD 200 91
25	1	438381	RH QUAD PLR STALK GUIDE WLD90
26	1	438384	LH QUAD PLR STALK GUIDE WLD90
27	1	390984	COTTER PIN 1/8 X 1 1/4
28	2	900004	1/4UNC X 1 1/4 HEX BOLT
29	2	914000	1/4UNC HEX STOVER NUT
30	1	438424	QUAD PLR MTR MT PLT WLD
31	2	900064	5/16UNC X 3/4 HEX BOLT
32	1	900830	5/16UNC X 2 HEX BOLT GR8
33	1	914002	5/16UNC HEX STOVER NUT
34	1	473805	ROLL PIN 1/4X1 1/2
35	2	483032	MACH WASH 1ID X 1.50D X.134TH

* NOTE: 1. DETAIL 14 CONSIST OF RIM AND HUB - 824511, TUBE - 824510, TIRE - 824509, STUD - 824513 WHEEL NUT - 824514

2. DETAIL 36 CONSIST OF RIM AND HUB - 824511, TUBE - 824510, TIRE - 824516, STUD - 824513 WHEEL NUT - 824514

3. DETAIL 37 & 38 ARE USED WITH THE 10-ROW OPTION.

DET.	QTY	PART NO.	DESCRIPTION
36	4	824515	410-4 WHL ASSY, 2P SAWTOOTH
37	1	618586	7/8MOR UNION
38	1	607522	FLOW REGULATOR, 8GPM VONBERG
39	16	824514	WHL NUT, 4-BOLT HUB
40	28	824513	STUD, 4-BOLT HUB
41	2	438503	.71 HUB SPACER, QUAD PLR
42	8	824509	4.10/3.50-4 2PLY STUD TIRE
43	8	824516	4.10/3.50 2P SAWTOOTH TIRE
44	8	824510	4.10/3.50-4 BENT STEM TUBE
45	4	824511	410-4 2PC RIM
46	16	910003	5/16UNF HEX NUT

4-BOLT RIM ASSEMBLY

TIRE PULLER HEAD ASSEMBLY

DET. QTY PART NO. DESCRIPTION

1	1	438000	TIRE PLR WLD 1977
2	1	438009	PLR SPINDLE
3	1	438010	HYD MTR HSNG MT WLD R H
4	1	438014	HYD MTR HSNG MT WLD LH
5	1	438015	HYD HUB WLD PLR
6	1	438048	PLR STALK GUIDE WLD
7	1	438050	INSIDE STALK GUIDE WLD
8	2	470053	1/4-20X1/4 AL HD SET SC CUP
9	1	472008	COTTER PIN 5/32X1LG
10	1	473060	1 IN 14 SAE HEX NUT UNPLATED
11	1	604005	ORBIT MOTOR A5E
12	1	611145	3/4MJIC-90-1/2MNPT LBO
13	1	611147	3/4MJIC-1/2MNPT ADPTR
14	1	824501	1 IN TAPER BRG HUB GROUP
15	2	824503	WHL W/480X12-B TIRE
16	1	900006	1/4UNC X 1 3/4 HEX BOLT
17	4	900064	5/16UNC X 3/4 HEX BOLT
18	4	900128	3/8UNC X 3/4 HEX BOLT
19	4	900130	3/8UNC X 1 1/4 HEX BOLT
20	1	900263	1/2UNC X 1 HEX BOLT
21	6	914004	3/8 UNC STOVER NUT
22	1	920500	LOCK WASH 1/4
23	4	920502	LOCK WASH 3/8
24	1	438173	TIRE PLR SHLD WLD
25	2	900129	3/8UNC X 1 HEX BOLT
26	1	472022	NO. 15 WOODRUFF KEY 1/4 X 1
27	1	824507	DUST CAP FOR 824501P01
28	2	824504	BRG FOR 824501P01
29	2	824506	BRG CUP FOR 824501P01
30	1	824505	SEAL FOR 824501P01
31	10	824052	WHEEL STUD NUT 1/2-20X60DEG
32	1	129003	SPINDLE NUT
33	1	920006	3/4 FLAT WASH SAE

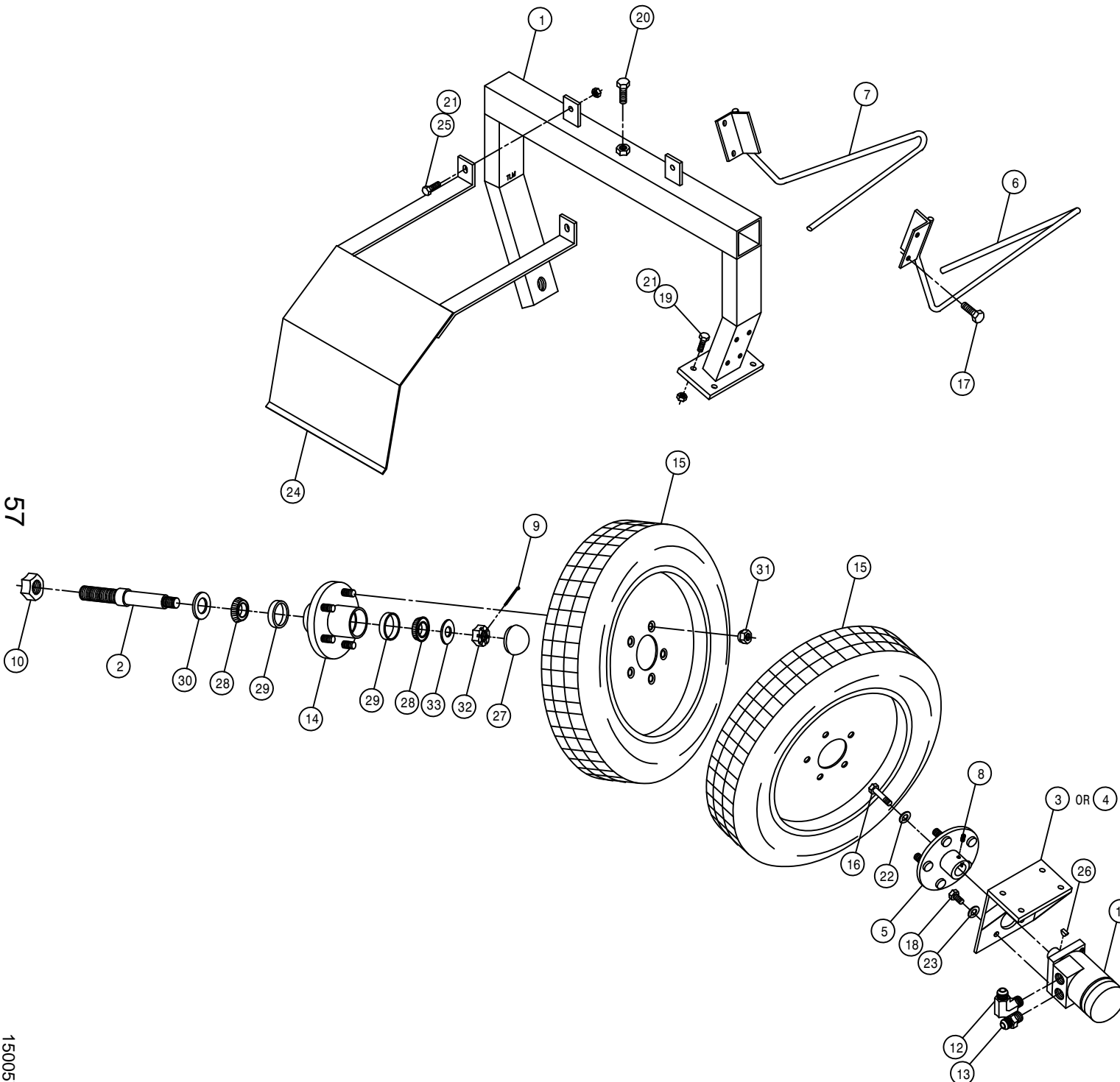

57

150057

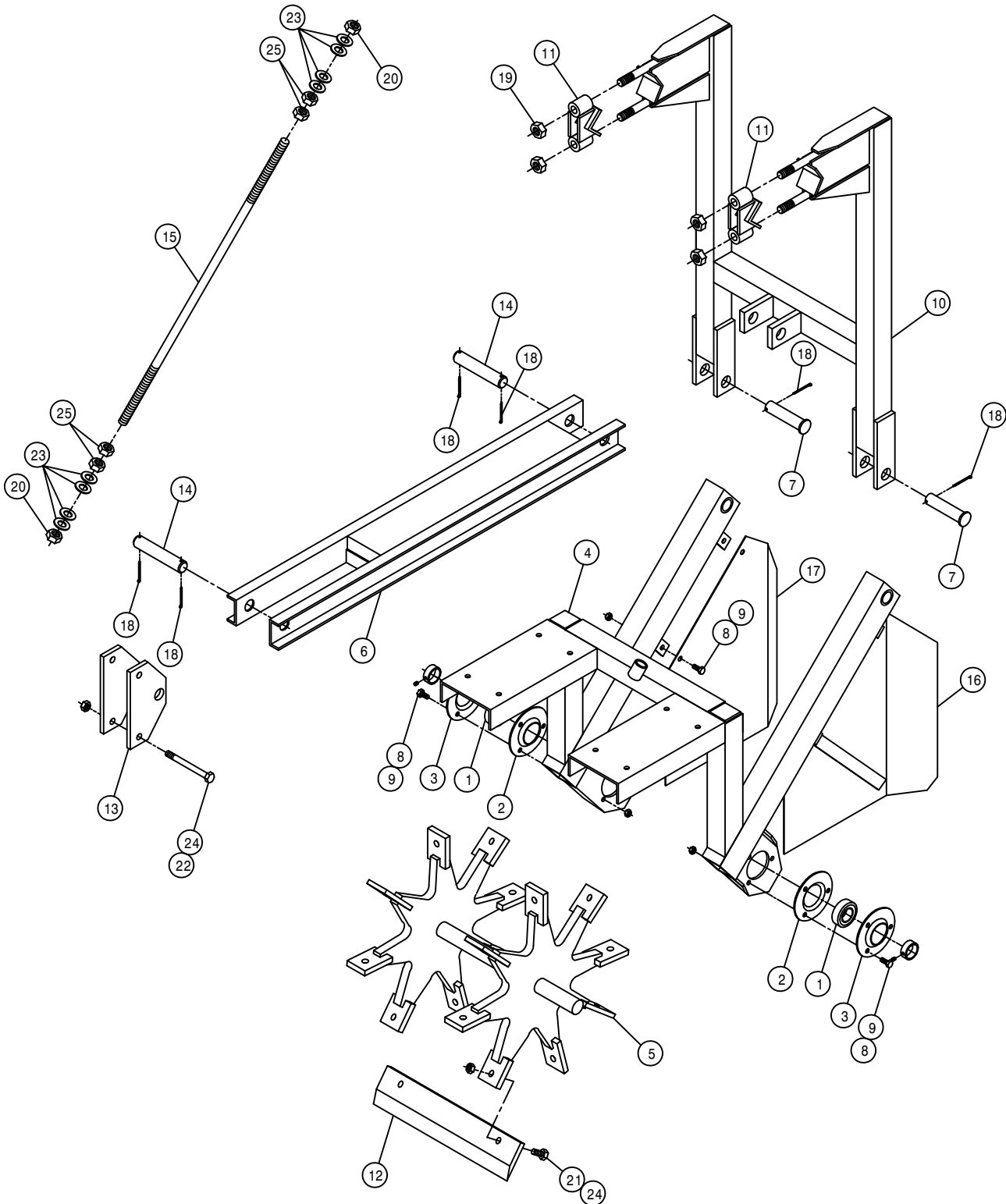

15" MALE ROW CHOPPER ASSEMBLY

DET. QTY PART NO. DESCRIPTION

1	2	123024	BGR 1 1/4 BORE SPHERICL RELUB
2	2	123026	FLANGETT 1 1/4
3	2	123035	FLANGETT 1 1/4 180 DEG ZERK
4	1	270814	LWR FRAME WLD MALE ROW CHOP
5	1	270860	BLADE MT WHL WLD, CHOPPER 92
6	1	270852	LWR LIFT ARM WLD MALE CHOP 91
7	2	472012	PICKER PIN 1 X 3 1/4
8	10	900129	3/8UNC X 1 HEX BOLT
9	10	914004	3/8UNC HEX STOVER NUT
10	1	270855	UPR FRAME WLD MALE ROW CHOP91
11	2	270833	TOOL BAR CLAMP WLD MALE CHOP
12	8	270838	CHOPPER BLADE 8131 STEEL TREA
13	2	270842	LWR LIFT ARM MTG PLT
14	2	270843	LIFT ARM PIN MALE ROW CHOPPER
15	1	270844	ADJ ROD MALE ROW CHOPPER
16	1	270845	RH SHLD WLD MALE ROW CHOPPER
17	1	270846	LH SHLD WLD MALE ROW CHOPPER
18	6	470162	COTTER PIN 3/16 X 1 1/2 SQCUT
19	4	914010	5/8UNC HEX STOVER NUT
20	2	914012	3/4UNC HEX STOVER NUT
21	16	900265	1/2UNC X 1 1/2 HEX BOLT
22	2	900275	1/2UNC X 4 1/2 HEX BOLT
23	8	920006	3/4 FLAT WASH SAE
24	18	914008	1/2UNC HEX STOVER NUT
25	4	910012	3/4UNC HEX NUT

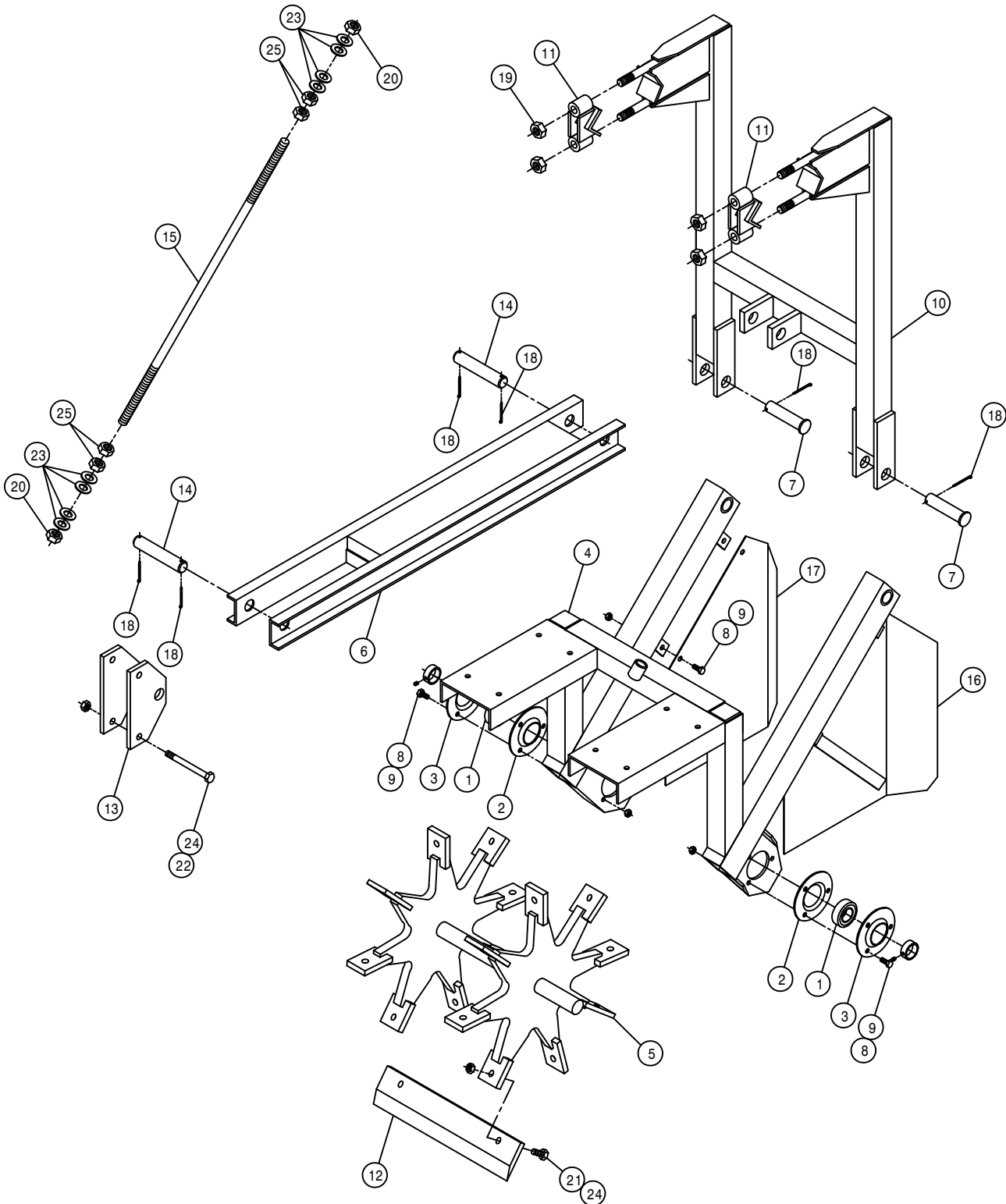

20" MALE ROW CHOPPER ASSEMBLY

DET. QTY PART NO. DESCRIPTION

1	2	123024	BGR 1 1/4 BORE SPHERICL RELUB
2	2	123026	FLANGETT 1 1/4
3	2	123035	FLANGETT 1 1/4 180 DEG ZERK
4	1	270872	LWR FRAME WLD,20"MALE CHOPR95
5	1	270874	BLADE MT WHL WLD,20"CHOPR 95
6	1	270852	LWR LIFT ARM WLD MALE CHOP 91
7	2	472012	PICKER PIN 1 X 3 1/4
8	10	900129	3/8UNC X 1 HEX BOLT
9	10	914004	3/8UNC HEX STOVER NUT
10	1	270876	UPR FRAME WLD,20"MALE CHOPR95
11	2	270833	TOOL BAR CLAMP WLD MALE CHOP
12	8	270866	CHOPPER BLADE,MALE ROW,20" 95
13	2	270842	LWR LIFT ARM MTG PLT
14	2	270843	LIFT ARM PIN MALE ROW CHOPPER
15	1	270867	ADJ ROD WLD,MALE ROW CHOPR 95
16	1	270845	RH SHLD WLD MALE ROW CHOPPER
17	1	270846	LH SHLD WLD MALE ROW CHOPPER
18	6	470162	COTTER PIN 3/16 X 1 1/2 SQCUT
19	4	914010	5/8UNC HEX STOVER NUT
20	2	914012	3/4UNC HEX STOVER NUT
21	16	900265	1/2UNC X 1 1/2 HEX BOLT
22	2	900275	1/2UNC X 4 1/2 HEX BOLT
23	8	920006	3/4 FLAT WASH SAE
24	18	914008	1/2UNC HEX STOVER NUT
25	4	910012	3/4UNC HEX NUT

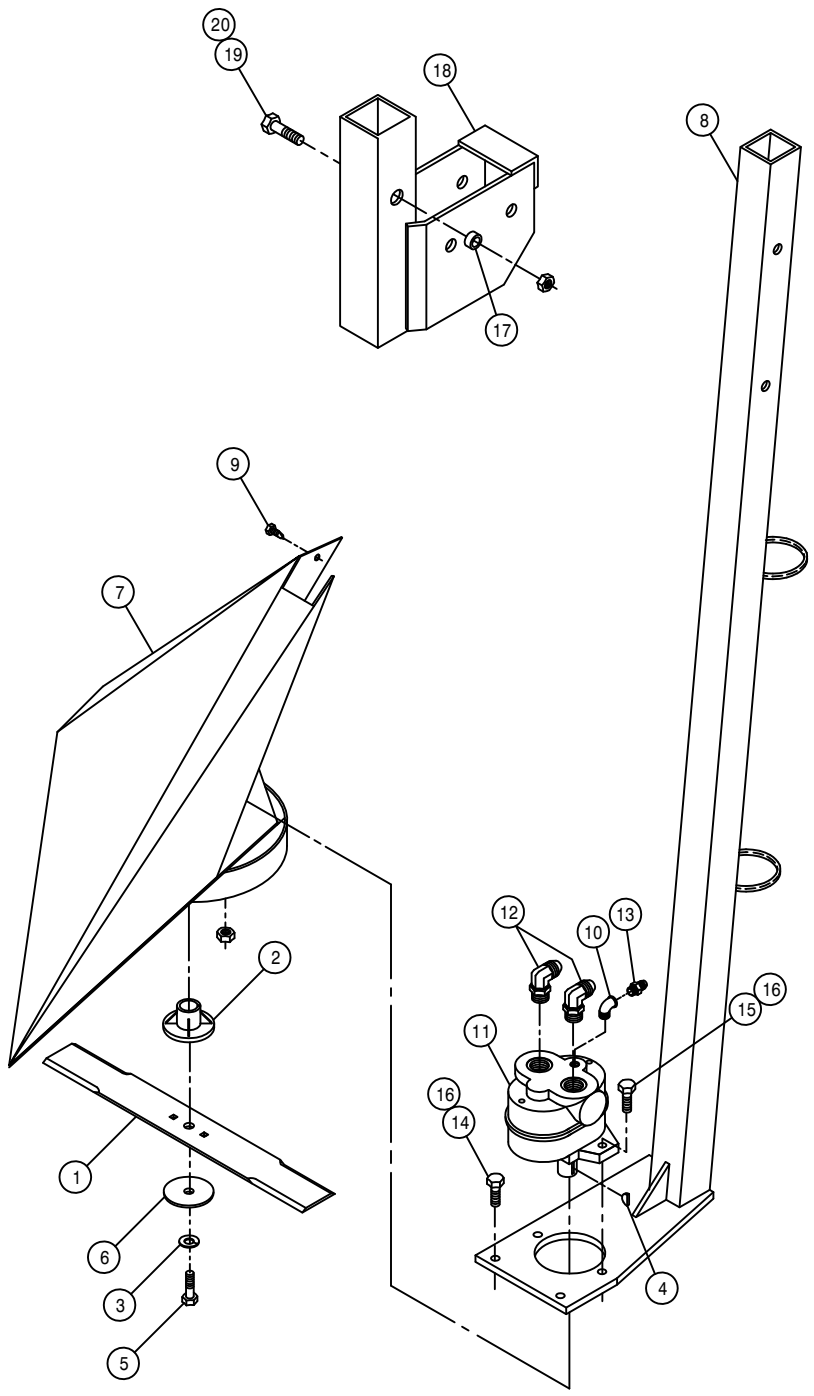

MALE CORN CUTTER ASSEMBLY

DET.	QTY	PART NO.	DESCRIPTION
1	1	002103	CUTR BLADE 18 IN
2	1	002104	CLUTCH BODY BLADE
3	1	002105	STEEL LOCK WASH CUTR BLADE
4	1	002106	WOODRUFF KEY #6 .156 X .625
5	1	002107	3/8UNF X 1 1/2 HEX BOLT CUTR
6	1	002108	STEEL WASHER CUTTER BLADE
7	1	270800	MALE CORN CUTR WLD
8	1	270805	MALE CORN CUTR DROP TUBE WLD
9	1	472349	1/4 X 3/4 20THD-IN TEK TYPE
10	1	500900	BLK PIPE ST EL 90DEG .125NPT
11	1	610590	BARNES HYD MOTOR
12	2	618241	3/4MJIC-90-3/4MOR LBO
13	1	618530	9/16MJIC-1/8MNPT ADPTR
14	2	900129	3/8UNC X 1 HEX BOLT
15	2	900132	3/8UNC X 1 3/4 HEX BOLT
16	4	914004	3/8UNC HEX STOVER NUT
17	1	200015	.75 OD X 11GA WA X .38LG C/L
18	1	270809	MALE CUTR ADPTR BRKT WLD 83
19	1	900273	1/2UNC X 3 3/4 HEX BOLT
20	1	914008	1/2UNC HEX STOVER NUT

MALE ROW 4-BLADE CUTTER ASSEMBLY

DET. QTY PART NO. DESCRIPTION

1	1	123021	LOCK COLLAR 1 1/4 DIA
2	2	123024	BGR 1 1/4 BORE SPHERICL RELUB
3	2	123026	FLANGETT 1 1/4
4	2	123035	FLANGETT 1 1/4 180 DEG ZERK
5	1	270880	RH 4-BLADE CUTTER FRAME WLD95
6	1	270881	LH 4-BLADE CUTTER FRAME WLD95
7	1	270896	LWR BRG MT WLD,4-BLD CUTR 95
8	1	270902	BLADE SHAFT,4-BLD CUTR 95
9	4	270903	BLADE MT HUB,4-BLD CUTR 95
10	4	270904	CUTTER BLADE,4-BLD CUTR 95
11	4	270905	UPPER BLADE SUPP,4-BLD CUTR95
12	4	270906	LWR BLADE SUPP,4-BLD CUTR 95
13	1	270907	CUTTER ADPT WLD,4-BLD CUTR 95
14	1	270910	CUTTER MT WLD,4-BLD CUTR 95
15	1	270913	RH ADJ ANG,4-BLD CUTR 95
16	1	270914	LH ADJ ANG,4-BLD CUTR 95
17	1	270915	RH SHIELD WLD,4-BLD CUTR 95
18	1	270916	LH SHIELD WLD,4-BLD CUTR 95
19	1	270923	DEFLECTOR SHLD,4-BLD CUTR 95
20	8	470057	SET SCREW SQ HD 5/16X1/2 LG
21	4	470121	1/4UNC HEX FLANGED LOCK NUT
22	4	470122	1/4UNC X 1/2 FLANGED HEX BOLT
23	1	492084	CHAIN FOR 492083 4016
24	1	492092	CHAIN CPLR 5/8 BORE 5/32 KWY
25	1	492091	CHAIN CPLR 1 1/4 BORE .25 KWY
26	1	610510	CESSNA GEAR MOTOR 1.48CI
27	1	610597	PRESS COMP FIXED FLO REG 18G
28	1	611121	9/16MJIC-1/4MNPT ADPTR
29	2	611145	3/4MJIC-90-1/2MNPT LBO
30	2	615626	08C1T-08FJX-08FJX-15 H/A
31	4	618451	3/4FJIC SW RUN TEE-3/4MJIC
32	1	618469	3/4MJIC-1 1/16MOR ADPTR
33	1	618474	3/4MJIC-90-1 1/16MOR LBO
34	1	618578	1 1/16FJIC SWIV-1 1/16MOR
35	1	690338	LINE CHECK VALVE HYD .50NPT
36	8	900002	1/4UNC X 3/4 HEX BOLT
37	8	900004	1/4UNC X 1 1/4 HEX BOLT
38	26	900129	3/8UNC X 1 HEX BOLT
39	2	900130	3/8UNC X 1 1/4 HEX BOLT
40	2	900263	1/2UNC X 1 HEX BOLT
41	2	900270	1/2UNC X 3 HEX BOLT
42	1	900273	1/2UNC X 3 3/4 HEX BOLT
43	1	900408	3/4UNC X 3 1/2 HEX BOLT
44	10	914000	1/4UNC HEX STOVER NUT
45	28	914004	3/8UNC HEX STOVER NUT
46	3	914008	1/2UNC HEX STOVER NUT
47	1	914012	3/4UNC HEX STOVER NUT
48	8	920000	1/4 FLAT WASH SAE
49	8	920500	LOCK WASH 1/4
50	1	270924	GUIDE MT WLD,4-BLD CUTR 95
51	1	270928	RH STALK GUIDE WLD,4-BLD CUTR
52	1	270929	LH STALK GUIDE WLD,4-BLD CUTR
53	2	900005	1/4UNC X 1 1/2 HEX BOLT
54	2	900069	5/16UNC X 2 HEX BOLT
55	2	914002	5/16UNC HEX STOVER NUT
56	2	920001	5/16 FLAT WASHER SAE PLT
57	5	472020	WOODRUFF KEY # 18 1/4 X 1 1/8
58	1	611127	1 1/16MJIC-1 1/16MOR ADPTR
59	1	200015	.75 OD X 11GA WA X .38LG C/L
60	1	470052	1/4-20X1/2 AL HD SET SC CUP
61	2	470060	5/16UNC X 3/8 SET SCR

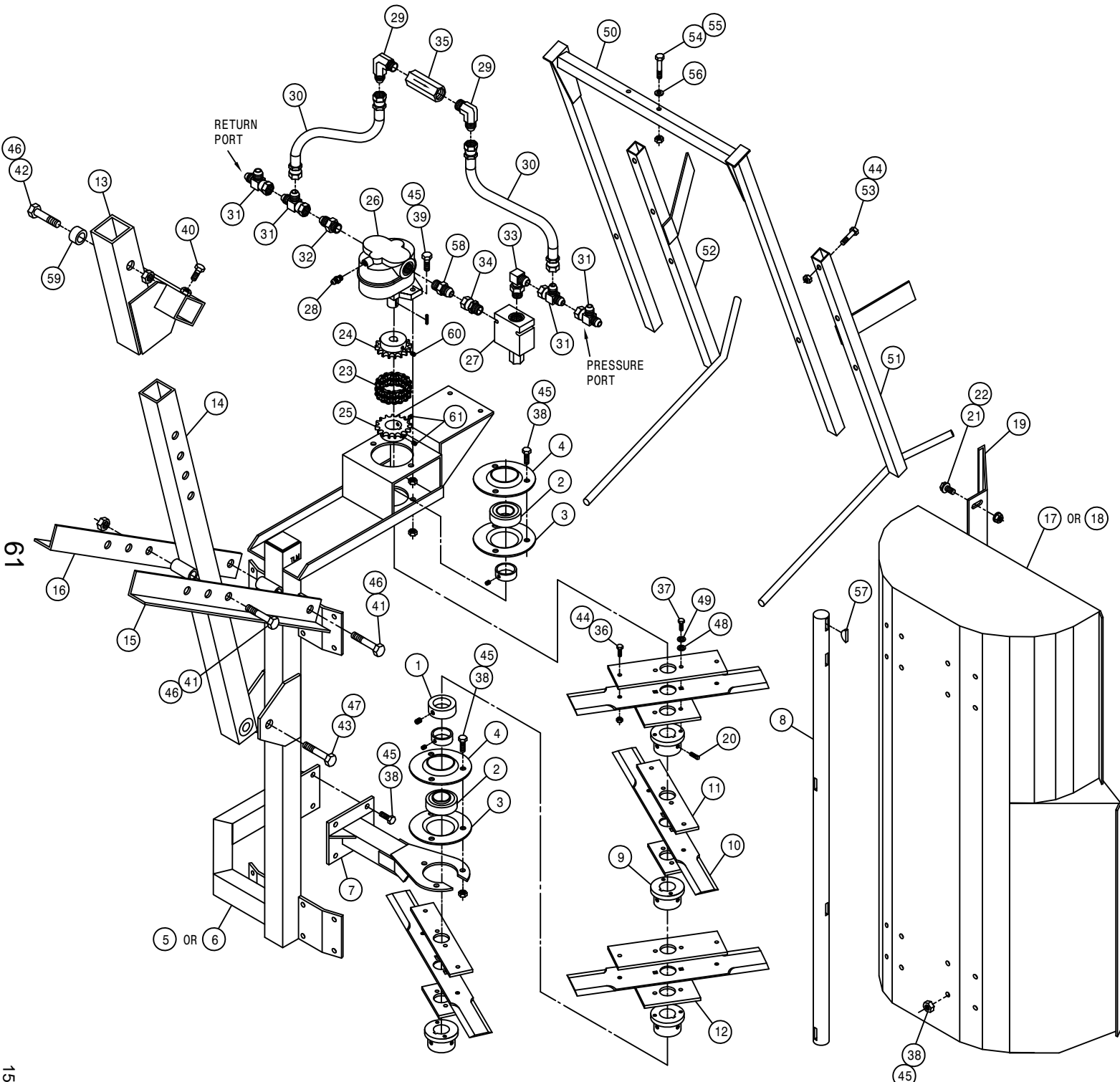

LS MANUAL SWITCH ASSEMBLY

LS CONTROL BOX ASSEMBLY

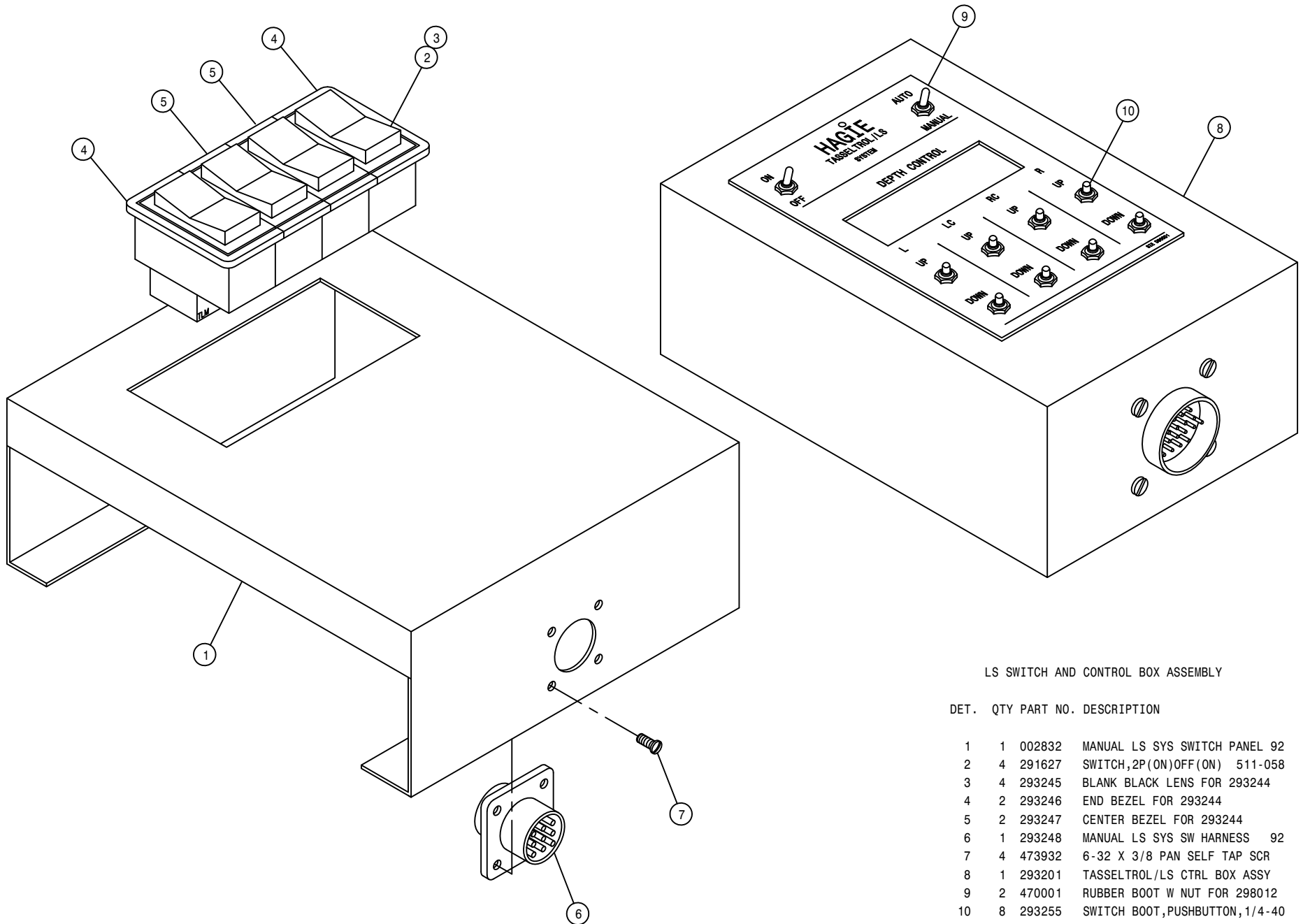

LS SWITCH AND CONTROL BOX ASSEMBLY

DET.	QTY	PART NO.	DESCRIPTION
1	1	002832	MANUAL LS SYS SWITCH PANEL 92
2	4	291627	SWITCH,2P(ON)OFF(ON) 511-058
3	4	293245	BLANK BLACK LENS FOR 293244
4	2	293246	END BEZEL FOR 293244
5	2	293247	CENTER BEZEL FOR 293244
6	1	293248	MANUAL LS SYS SW HARNESS 92
7	4	473932	6-32 X 3/8 PAN SELF TAP SCR
8	1	293201	TASSELTROL/LS CTRL BOX ASSY
9	2	470001	RUBBER BOOT W NUT FOR 298012
10	8	293255	SWITCH BOOT,PUSHBUTTON,1/4-40

63

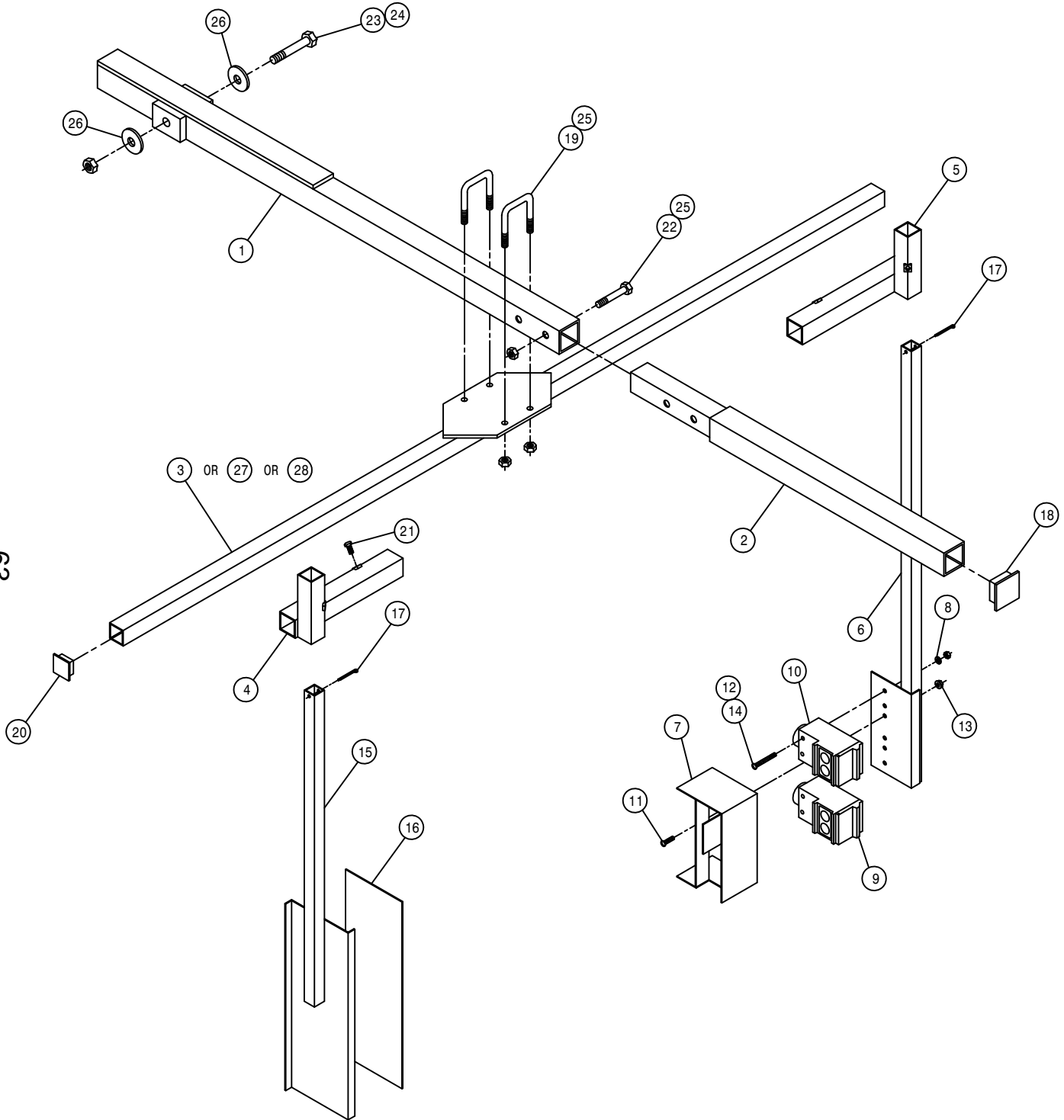

LS SENSOR ASSEMBLY

DET.	QTY	PART NO.	DESCRIPTION		
1	1	002813	SENSOR ARM WELD 200 DET	92	
2	1	002684	SENSOR ARM EXTEN WLD 200	90	
3	1	002709	LS CROSSTUBE WLD	90	
4	1	002712	LS REFLECTOR SLIDE MT WLD	90	
5	1	002713	LS SENSOR SLIDE MT WLD	90	
6	1	002839	LS 42GRU PHOTOSW SENSR MT WLD		
7	1	002841	LS 42GRU SENSOR SHIELD WLD		
8	2	920510	LOCK WASH NO 10		
9	1	293258	LWR LS 9000 SENSOR ASSY, FEM		
10	1	293259	UPR LS 9000 SENSOR ASSY, MALE		
11	2	903883	10-32 X 1/2 SLTRD HD MACH SCR		
12	2	910027	#10-32 HEX NUT		
13	2	470175	#10-32 HEX FLANGED LOCK NUT		
14	4	903902	10-32 X 2 SLT RD HD MACH SCR		
15	1	002723	LS REFLECTOR MT WLD	90	
16	1	650310	LS REFLECTOR 4 X 12	90	
17	2	390984	COTTER PIN 1/8 X 1 1/4		
18	1	473943	FINISH PLUG 1 1/2 SQ		
19	2	473949	5/16UNC-1 9/16ID-1 15/16UBOLT		
20	2	629727	FINISH PLUG FOR 1 IN X 16 GA		
21	4	900000	1/4UNC X 1/2 HEX BOLT		
22	2	900069	5/16UNC X 2 HEX BOLT		
23	1	900275	1/2UNC X 4 1/2 HEX BOLT		
24	1	914008	1/2UNC HEX STOVER NUT		
25	6	914002	5/16UNC HEX STOVER NUT		
26	2	002815	SENSOR ARM WASH, NYL		
27	1	002834	LS CROSSTUBE WLD 10-12R	92	
28	1	002876	LS CROSSTUBE WLD, 62"	94	

NOTE: DETAIL 2, 22, AND 25 ARE USED WITH THE TIRE PULLER OPTION.

2-3-4 LIFT, DEPTH COMMAND SWITCH ASSEMBLY

DET.	QTY	PART NO.	DESCRIPTION
	1	002744	SWITCH BOX, DEPTH CMD
	2	002745	SWITCH BOX MT, DEPTH CMD
	3	470122	1/4UNC X 1/2 FLANGE HEX BOLT
	4	658174	BUMPER PLUG FOR 1/2 HOLE
	5	291602	FUSE 10 AMP
	6	293172	TOGGLE SWITCH DPDT W/JUMPERS
	7	298011	FUSE HOLDER
	8	470001	RUBBER BOOT W NUT FOR 298012
	9	473914	RUBBER GROMMET 9/16 ID
	10	473829	3MM-0.50 X 16MM PANHEAD SCREW
	11	470121	1/4UNC HEX FLANGE LOCK NUT

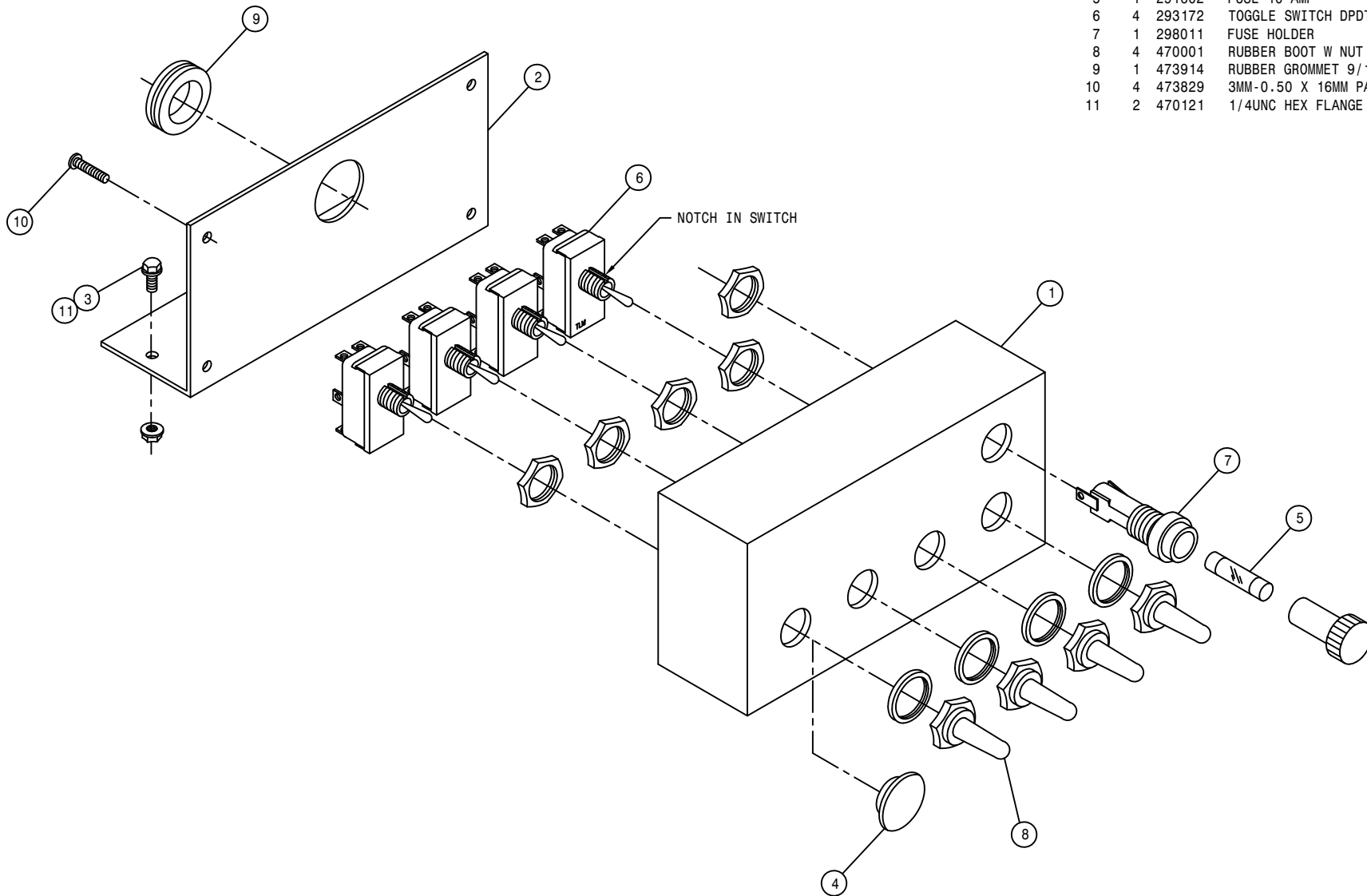

DEPTH COMMAND ACTUATOR ASSEMBLY

DET. QTY PART NO. DESCRIPTION

1	1	002849	HD DEPTH CMD ARM MT WLD	94
2	1	002846	HD DEPTH CMD MTG BRKT WLD	94
3	1	002851	HD DEPTH CMD UPR ARM WLD	94
4	1	002855	HD DEPTH CMD LWR ARM WLD	94
5	2	002858	HD DEPTH CMD ARM BUSH	94
6	1	291634	LINEAR ACTUATOR, 12V 4" 250LB	
7	2	473949	5/16UNC-1 9/16ID-1 15/16BOLT	
8	1	900267	1/2UNC X 2 HEX BOLT	
9	1	900069	5/16UNC X 2 HEX BOLT	
10	1	900070	5/16UNC X 2 1/2 BOLT	
11	2	900263	1/2UNC X 1 HEX BOLT	
12	2	914008	1/2UNC HEX STOVER NUT	
13	6	914002	5/16UNC HEX STOVER NUT	
14	2	920004	1/2 FLAT WASHER SAE	
15	1	900275	1/2UNC X 4 1/2 HEX BOLT	

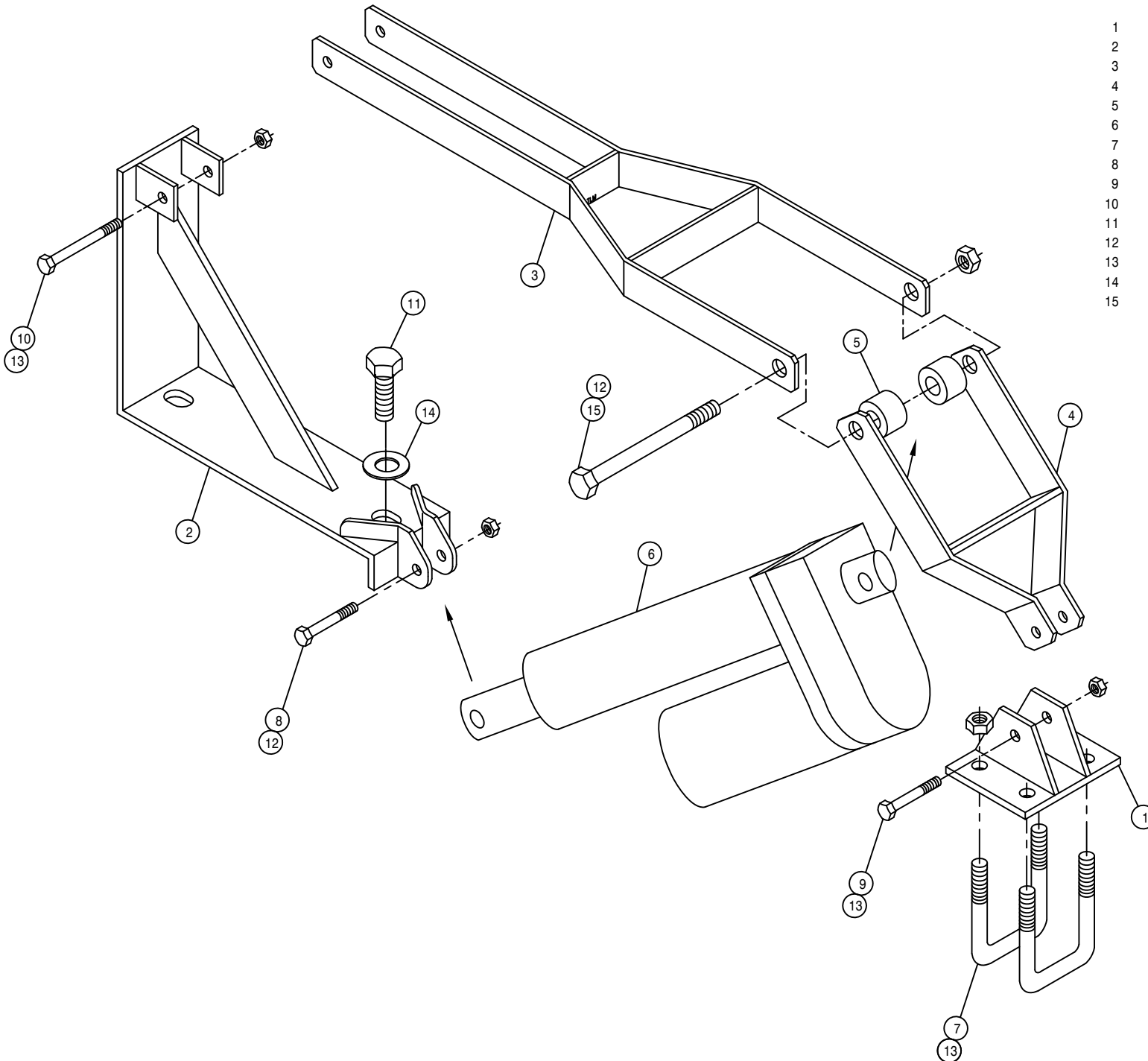

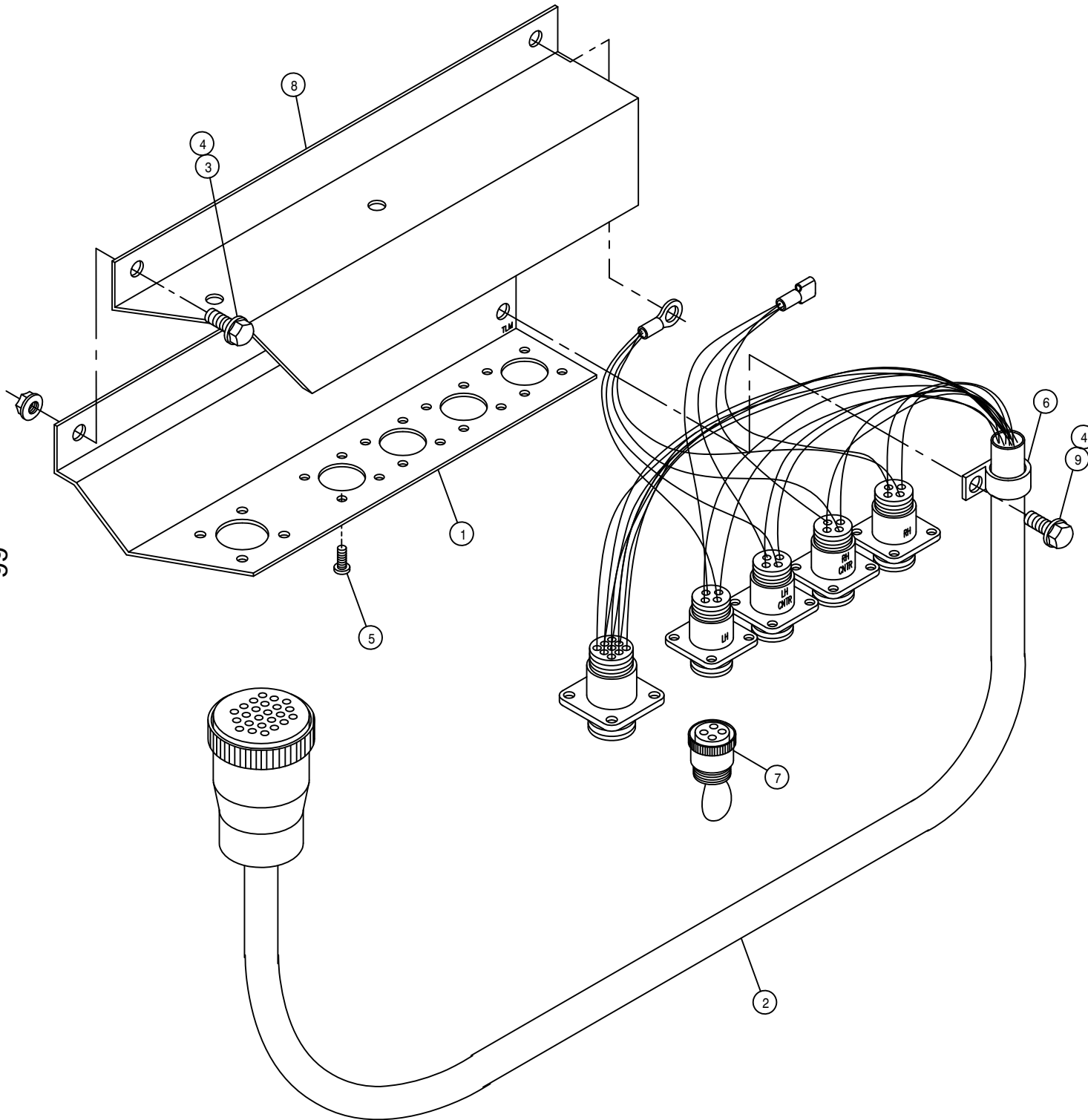

LS RECEPTACLE ASSEMBLY

DET. QTY PART NO. DESCRIPTION

1	1	002777	T-TROL/LS RECEPTACLE MT
2	1	293200	MAIN CONTROL WIRE ASSY LS 90
3	2	470118	1/4UNC X 3/4 FLANGED HEX BOLT
4	3	470121	1/4UNC HEX FLANGED LOCK NUT
5	20	473932	SCREW, SELF TAP 6/32 X 3/8PAN
6	1	520118	CUSH HOSE CLAMP 1/2D X 1/2W
7	1	293211	JUMPER PLUG, T-TROL/LS SYS
8	1	002879	RECEPTACLE MT COVER, 204 94
9	1	470122	1/4UNC X 1/2 FLANGED HEX BOLT

NOTE: DETAIL 7 IS USED (1) WITH 3-LIFT OPTION
AND (2) WITH 2-LIFT OPTION.

CROSS-SECTIONAL VIEW OF W1B TORQUE-HUB®

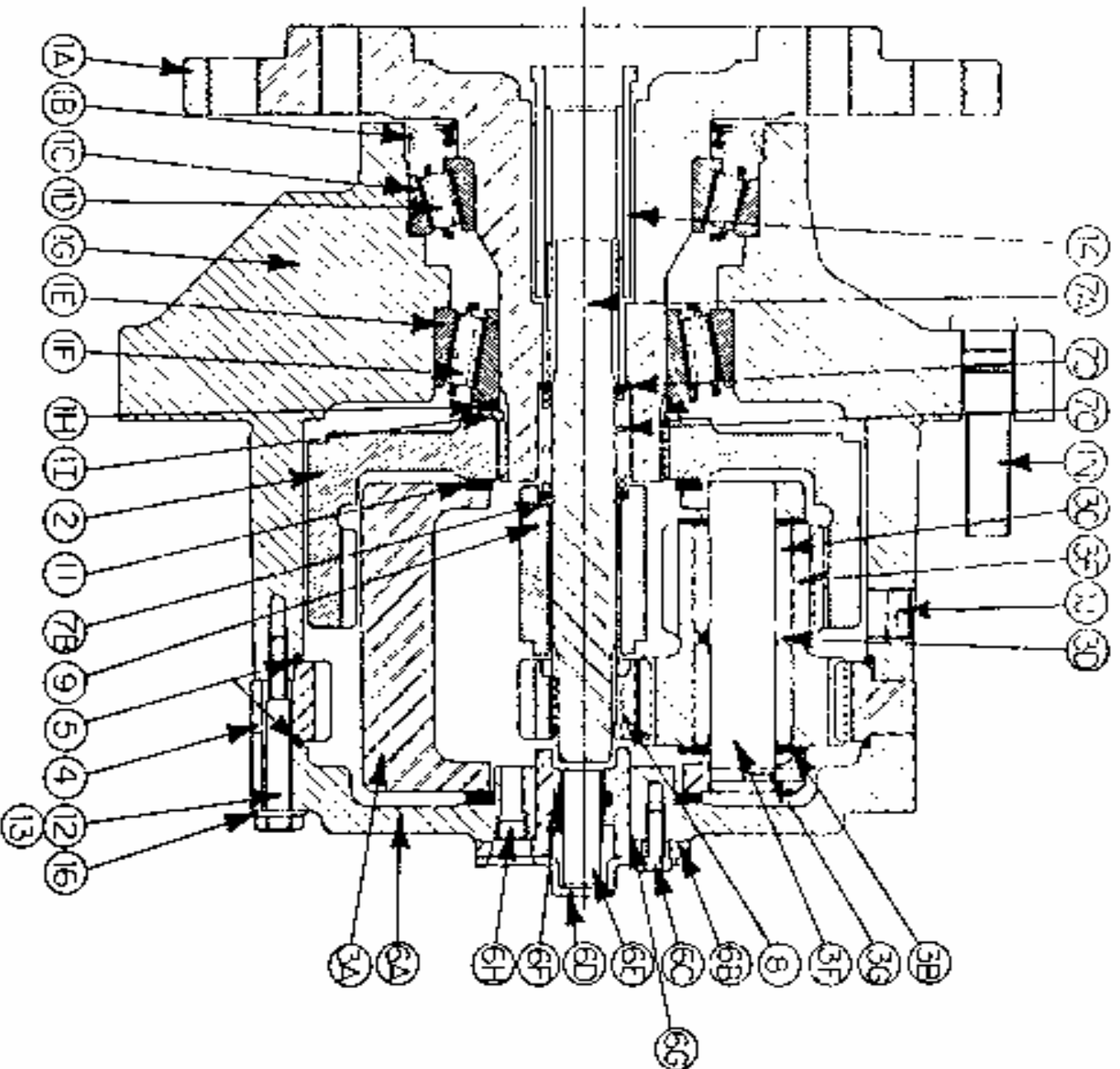

WHEEL DRIVE ASSEMBLY - 610515
W1BFNZ318

ITEMS	DESCRIPTION	PART NO.	QTY.
1	HUB-SPINDLE SUB-ASSEMBLY	-----	
1A	SPINDLE	610518	1
1B	SEAL	610519	1
1C	BEARING CUP	610520	1
1D	BEARING CONE	610521	1
1E	BEARING CUP	610907	1
1F	BEARING CONE	610908	1
1G	HUB	610522	1
1H	SPACER	610909	1
1I	RETAINER RING	610910	1
1J	PIPE PLUG	610147	2
1N	STUD	610523	9
2	INTERNAL GEAR	610148	1
3	CARRIER ASSEMBLY	610912	1
4	RING GEAR	610929	1
5	O-RING	610903	2
6	COVER ASSEMBLY	610155	1
6A	COVER	610149	1
6B	COVER CAP	610914	1
6C	BOLT	610150	4
6D	DISCONNECT CAP	610901	1
6E	DISCONNECT ROD	610915	1
6F	O-RING	610916	1
6G	O-RING	610917	1
6H	PIPE NIPPLE	610151	1
6I	ID PLATE	610152	1
7	INPUT SHAFT ASSEMBLY	610048	1
7A	INPUT SHAFT	610046	1
7B	RETAINING RING	610936	1
7C	SPRING	610145	1
7D	SPACER	610153	2
8	INPUT GEAR	610919	1
9	THRUST SPACER	610920	1
10	THRUST SPACER	610921	1
11	THRUST WASHER	610922	2
12	BOLT	610930	12
13	SHOULDER BOLT	610923	4
14	COUPLING	610037	1
16	FLAT WASHER	610049	16
NS	SEAL BOOT	610552	1

WHEEL DRIVE ASSEMBLY - 610516
W1BFNZ324

ITEMS	DESCRIPTION	PART NO.	QTY.
1	HUB-SPINDLE SUB-ASSEMBLY	-----	
1A	SPINDLE	610518	1
1B	SEAL	610519	1
1C	BEARING CUP	610520	1
1D	BEARING CONE	610521	1
1E	BEARING CUP	610907	1
1F	BEARING CONE	610908	1
1G	HUB	610522	1
1H	SPACER	610909	1
1I	RETAINER RING	610910	1
1J	PIPE PLUG	610147	2
1N	STUD	610523	9
2	INTERNAL GEAR	610148	1
3	CARRIER ASSEMBLY	610933	1
4	RING GEAR	610937	1
5	O-RING	610903	2
6	COVER ASSEMBLY	610155	1
6A	COVER	610149	1
6B	COVER CAP	610914	1
6C	BOLT	610150	4
6D	DISCONNECT CAP	610901	1
6E	DISCONNECT ROD	610915	1
6F	O-RING	610916	1
6G	O-RING	610917	1
6H	PIPE NIPPLE	610151	1
6I	ID PLATE	610152	1
7	INPUT SHAFT ASSEMBLY	610048	1
7A	INPUT SHAFT	610046	1
7B	RETAINING RING	610936	1
7C	SPRING	610145	1
7D	SPACER	610153	2
8	INPUT GEAR	610919	1
9	THRUST SPACER	610920	1
10	THRUST SPACER	610921	1
11	THRUST WASHER	610922	2
12	BOLT	610930	12
13	SHOULDER BOLT	610923	4
14	COUPLING	610037	1
16	FLAT WASHER	610049	16
NS	SEAL BOOT	610552	1

NOTICE

The following page contains decals for the model 204.

These decals can be obtained from Hagie Mfg. Co. and should be used whenever your machine is repainted or when the decals become worn, weathered, or faded.

Special attention should be paid to decals involving personal safety. They have been attached for your protection.

KEEP THEM IN PLACE.

Contact: Hagie Manufacturing Co.
Box 273
Clarion, Iowa 50525

204 DECALS

QTY.	PART NO.	DESCRIPTION	LOCATION
1	650831	EMERGENCY STOP DECAL	ON CONSOLE SHEET METAL
1	650329	TRACTION VALVE DECAL	ON INSTRUMENT PANEL
2	650953	GASOLINE DECAL	NEAR EACH FUEL TANK NECK
1	650814	PARK BRAKE DECAL	NEAR PARK BRAKE
2	650819	DANGER, CUTTING BLADES	2-ON EACH CUTTER HEAD
1	650847	NO PASSENGER DECAL	ON FRONT OPERATOR STATION
1	650848	SLIP OR FALL DECAL	NEXT TO STEP ON LEG RAIL
2	650849	ENGINE FUEL DECAL	NEAR EACH FUEL TANK NECK
4	650985	WHEEL BOLT TORQUE DECAL	ON EACH WHEEL RIM
2	650851	SHIELDS DECAL	ON SIDE OF TOP ENGINE COVER
1	650852	READ MANUAL DECAL	ON FRONT OPERATOR STATION
1	650981	COOLING SYSTEM DECAL	NEAR RADIATOR CAP
1	650982	ELECTRICAL DECAL	RIGHT HAND SIDE OF OIL TANK
3	650931	HAGIE DECAL 1 3/4 X 4	1 - ON EACH TASSEL DEFLECTOR 1 - ON EACH QUAD PULLER
4	650820	CAUTION MOVING PARTS DECAL	2 - EACH TASSEL DEFLECTOR 1 - ON EACH QUAD PULLER 1 - ON EACH TIRE PULLER
2	650954	DIESEL DECAL	NEAR EACH FUEL TANK NECK
1	650321	DECAL SET, HAGIE 204 STRIPE	ON EACH ENGINE HOOD
1	650319	DECAL, NOTICE LEG CYL OIL	ON TOP LH FRT LEG
2	650308	LEFT L-CTR R-CTR RIGHT DECAL	1 - ON CONSOLE COVER 1 - DEPTH COMMAND SWITCH BOX
1	650332	MTR CTRL-FUEL-FLASH DECALL	ON CONSOLE COVER
1	650955	CAUTION SLOW ENG IDL DECAL	ON CONSOLE COVER
1	650967	THROTTLE DECAL	ON CONSOLE COVER
1	650968	HYDRO DRIVE DECAL	ON CONSOLE COVER
1	650881	CHOKE DECAL	ON CONSOLE COVER
1	650333	10 AMP FUSE DECAL	ON CONSOLE COVER

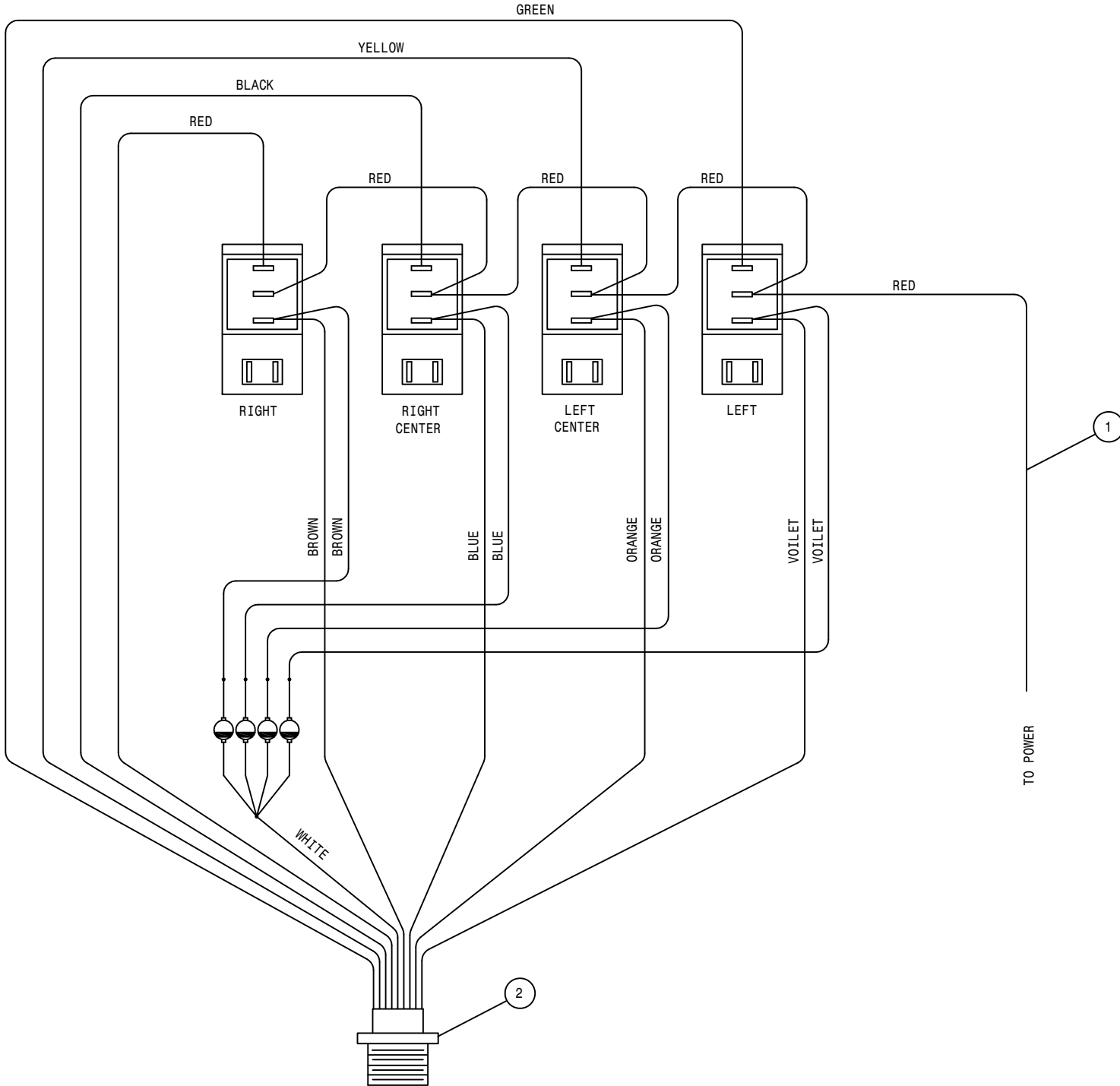

72

150072

2	1	293248	MANUAL LS SYS SW HARNESS
1	1	293249	MANUAL LS SYS PWR WIRE ASSY
DET	REQ	DESCRIPTION	
HAGIE HAGIE MANUFACTURING COMPANY CLARION, IOWA 50525			
REMOVE ALL SHARP CORNERS & BURRS			
TOLERANCE UNLESS OTHERWISE SPECIFIED			
FRACTION	± 1/32	DECIMALS	X.XX ±.03 X.XXX ±.005
ANGLES	± °		
DESCRIPTION WIRING DIAG. MANUAL LS SYS SW			
DRAWN BY T. MARKER		SCALE NONE	
CHECKED BY		APPROVED BY	
DATE 05-06-92		DRAWING NUMBER 498414	
SHEET OF			

NOTE: NOTCH IN SWITCH

293168 - 2L DEPTH CMD NEG WIRE ASSY

TO GROUND

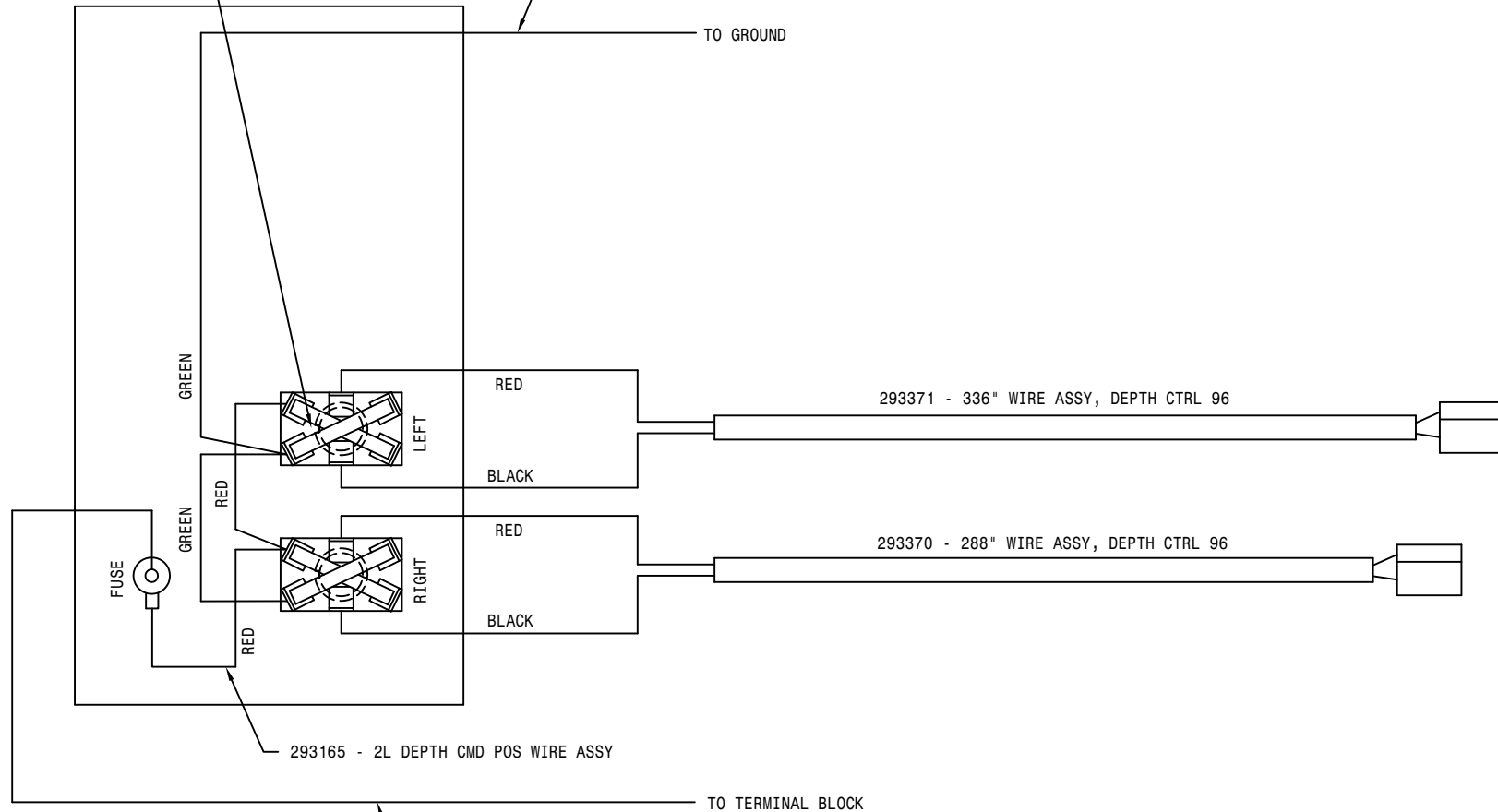

293165 - 2L DEPTH CMD POS WIRE ASSY

TO TERMINAL BLOCK

293338 - 16GA BLK-291580-293147-20 W/A

DET	REQ	DESCRIPTION		
HAGIE HAGIE MANUFACTURING COMPANY <small>CLARION, IOWA 50525</small>				
REMOVE ALL SHARP CORNERS & BURRS				
TOLERANCE UNLESS OTHERWISE SPECIFIED				
FRACTION	1/32	DECIMALS	X.XX X.XXX	ANGLES
			°.03 °.005	!*
DESCRIPTION				
WIRE DIAG, 2-LIFT DEPTH CMD 94				
DRAWN BY		SCALE		
T. MARKER		NONE		
CHECKED BY		APPROVED BY		
DATE		DRAWING NUMBER		
03-29-94		498450		
SHEET		OF		

NOTE: NOTCH IN SWITCH

293169 - 3L DEPTH CMD NEG WIRE ASSY

TO GROUND

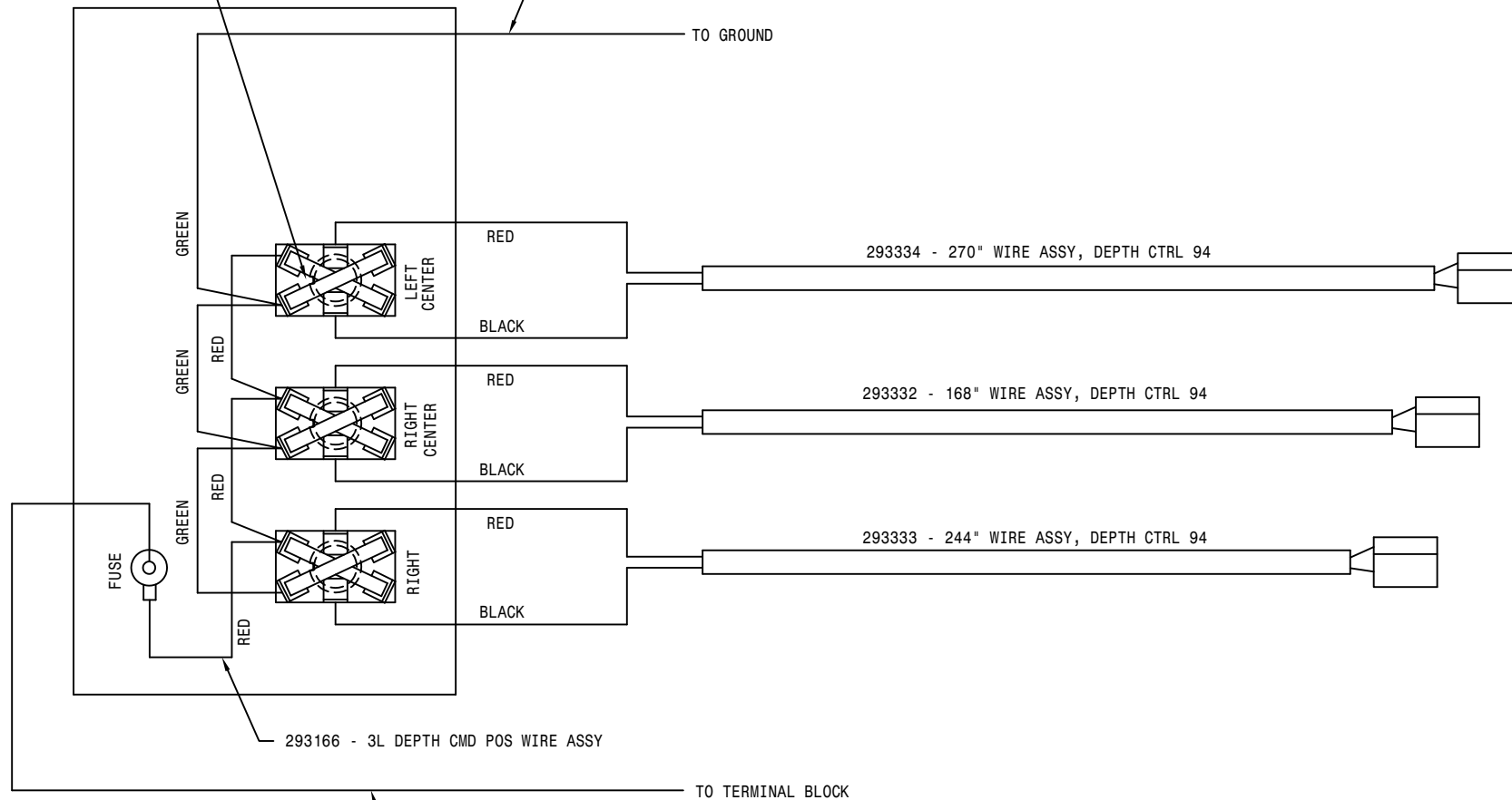

293166 - 3L DEPTH CMD POS WIRE ASSY

TO TERMINAL BLOCK

293338 - 16GA BLK-291580-293147-20 W/A

74

DET	REQ	DESCRIPTION		
 HAGIE MANUFACTURING COMPANY CLARION, IOWA 50525				
REMOVE ALL SHARP CORNERS & BURRS				
TOLERANCE UNLESS OTHERWISE SPECIFIED				
FRACTION	1/32	DECIMALS	X.XX X.XXX	ANGLES
			.03 .005	! *
DESCRIPTION				
WIRE DIAG, 3-LIFT DEPTH CMD 94				
DRAWN BY		SCALE		
T. MARKER		NONE		
CHECKED BY		APPROVED BY		
DATE		DRAWING NUMBER		
03-29-94		498451		
SHEET OF				

150074

NOTE: NOTCH IN SWITCH

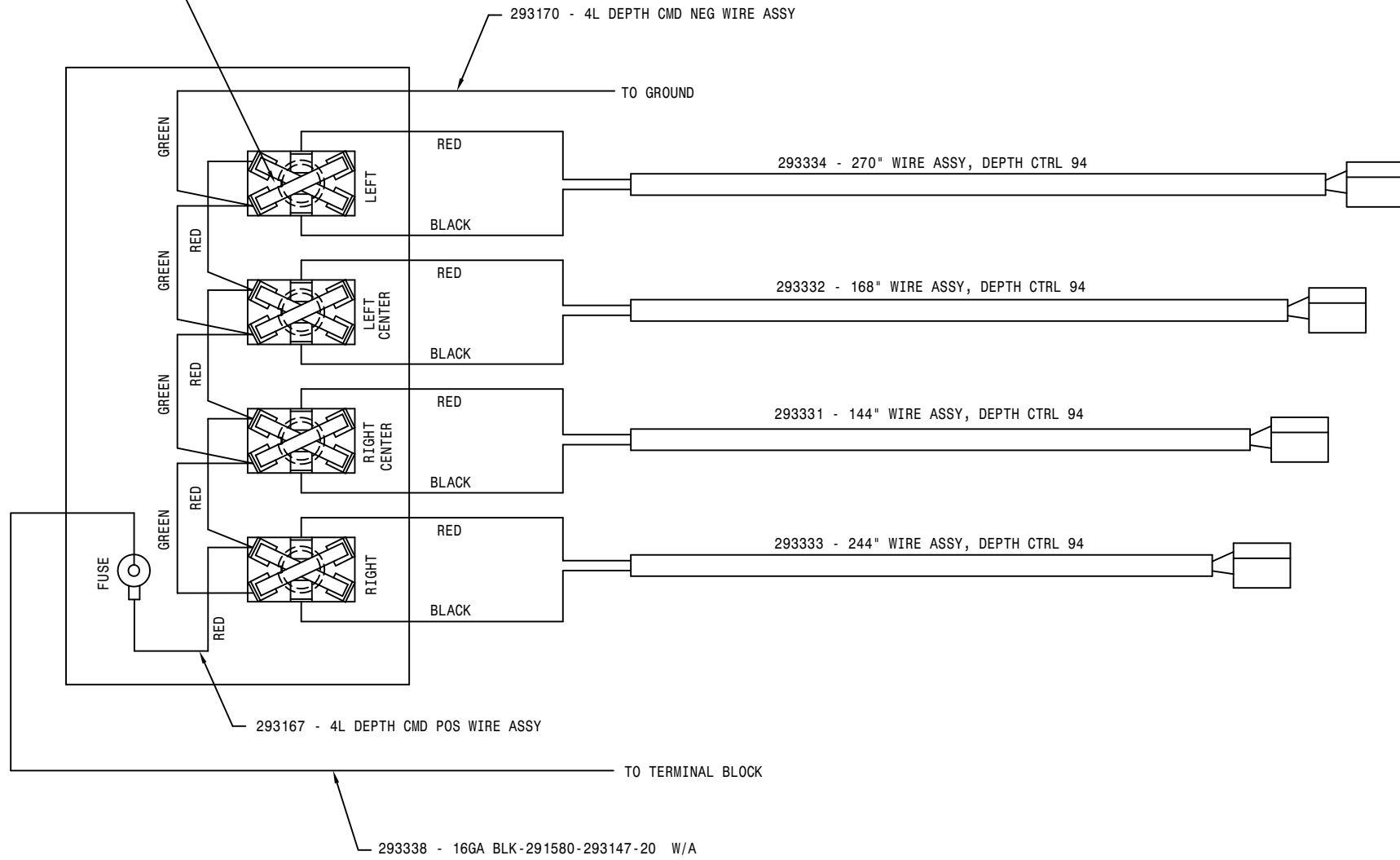

75

150075

DET	REQ	DESCRIPTION		
HAGIE HAGIE MANUFACTURING COMPANY CLARION, IOWA 50525				
REMOVE ALL SHARP CORNERS & BURRS TOLERANCE UNLESS OTHERWISE SPECIFIED				
FRACTION	1/32	DECIMALS	X.XX X.XXX	°03 °005
DESCRIPTION	WIRE DIAG, 4-LIFT DEPTH CMD 94			
DRAWN BY	T. MARKER	SCALE	NONE	
CHECKED BY		APPROVED BY		
DATE	03-29-94	DRAWING NUMBER	498452	
SHEET	OF			

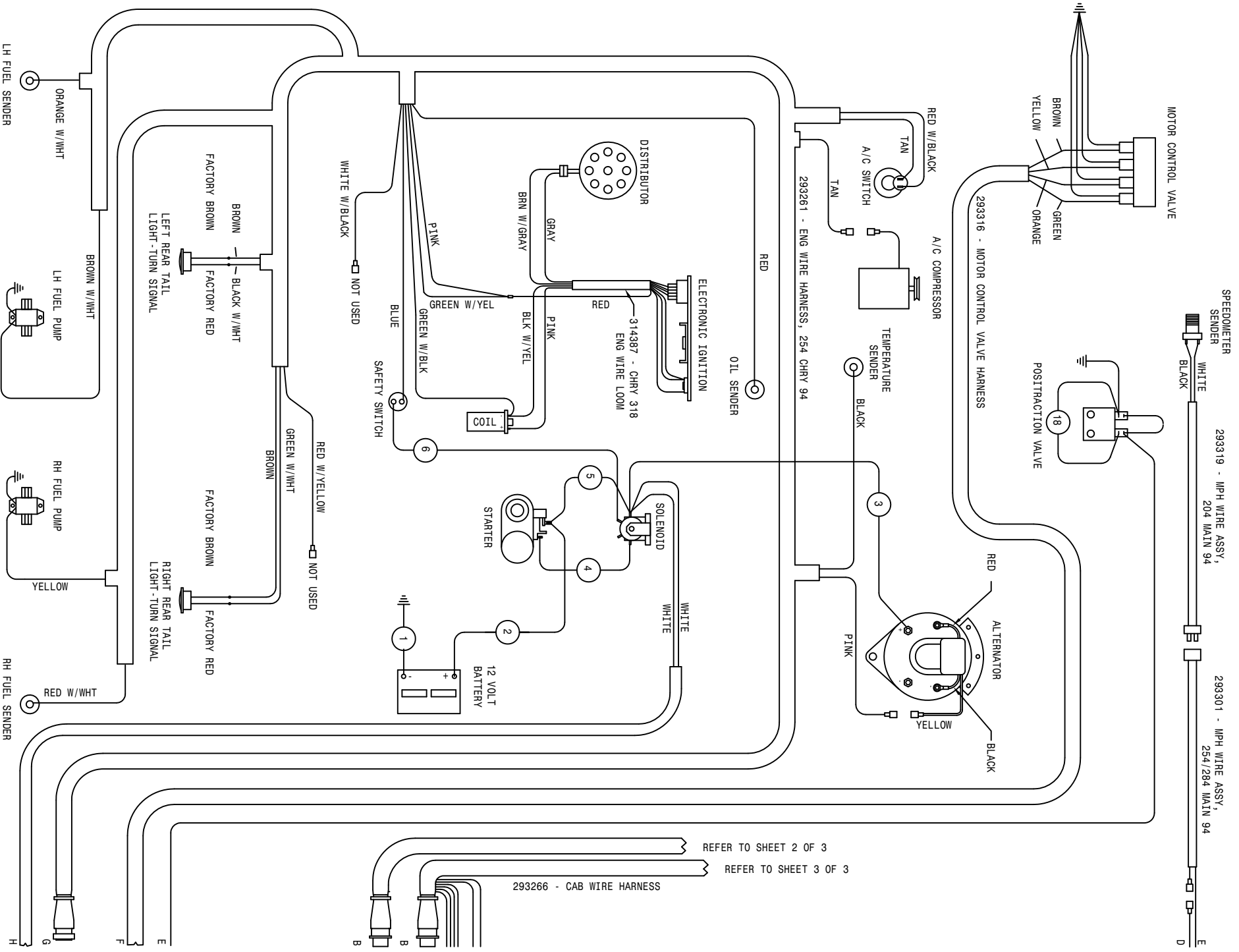

REFER TO SHEET 2 OF 3

REFER TO SHEET 3 OF 3

293266 - CAB WIRE HARNESS

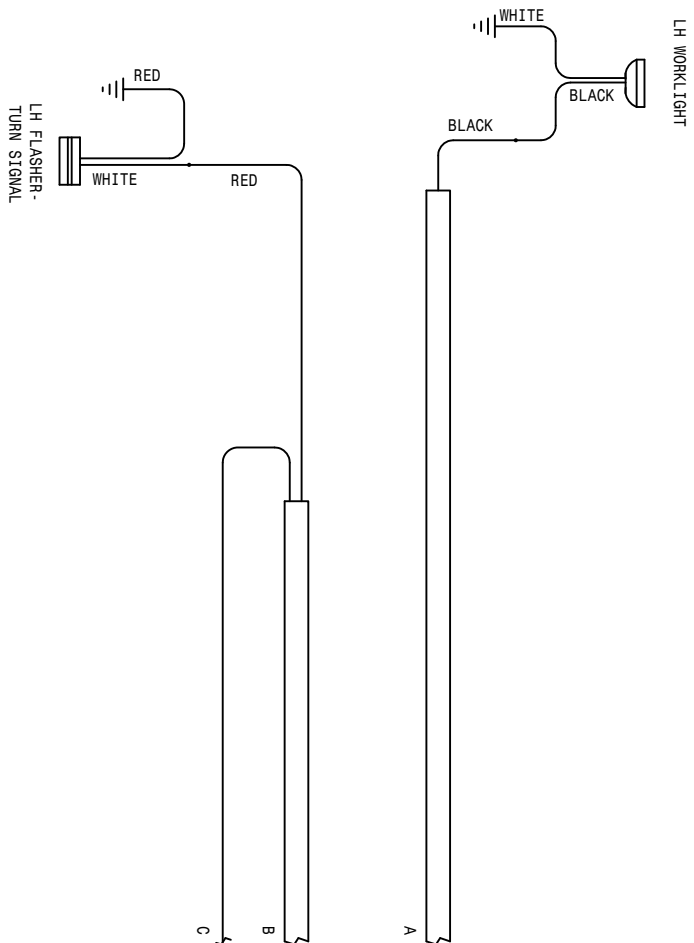
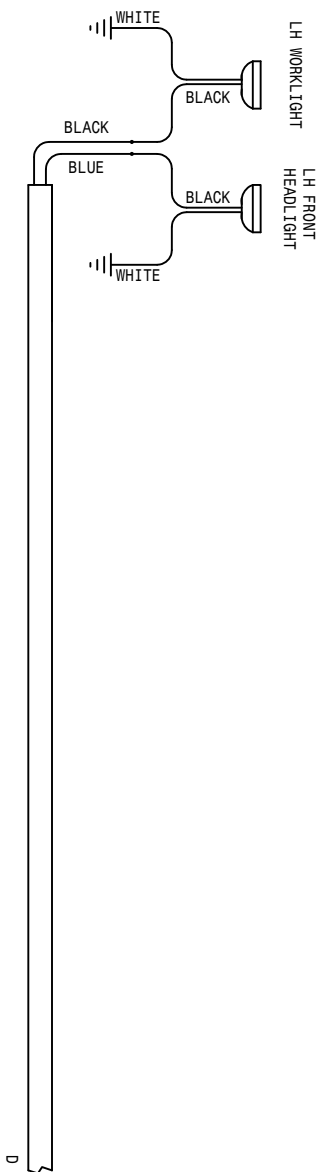
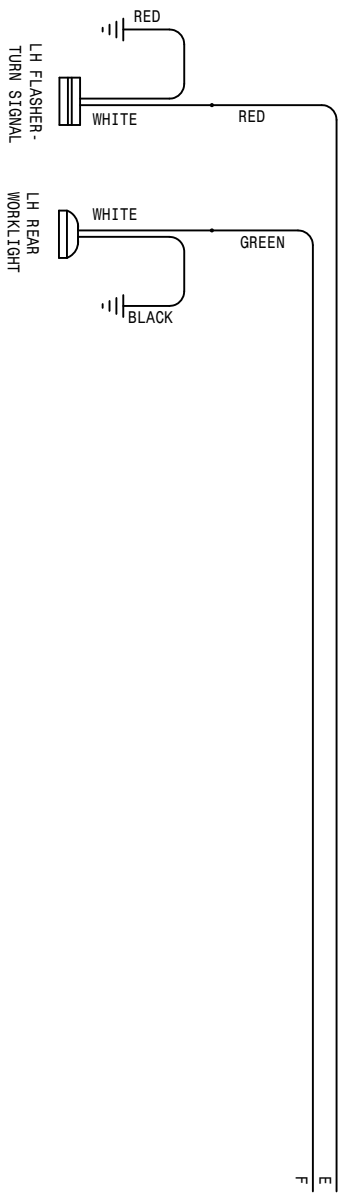

OPERATOR STATION LIGHT WIRING DIAGRAM

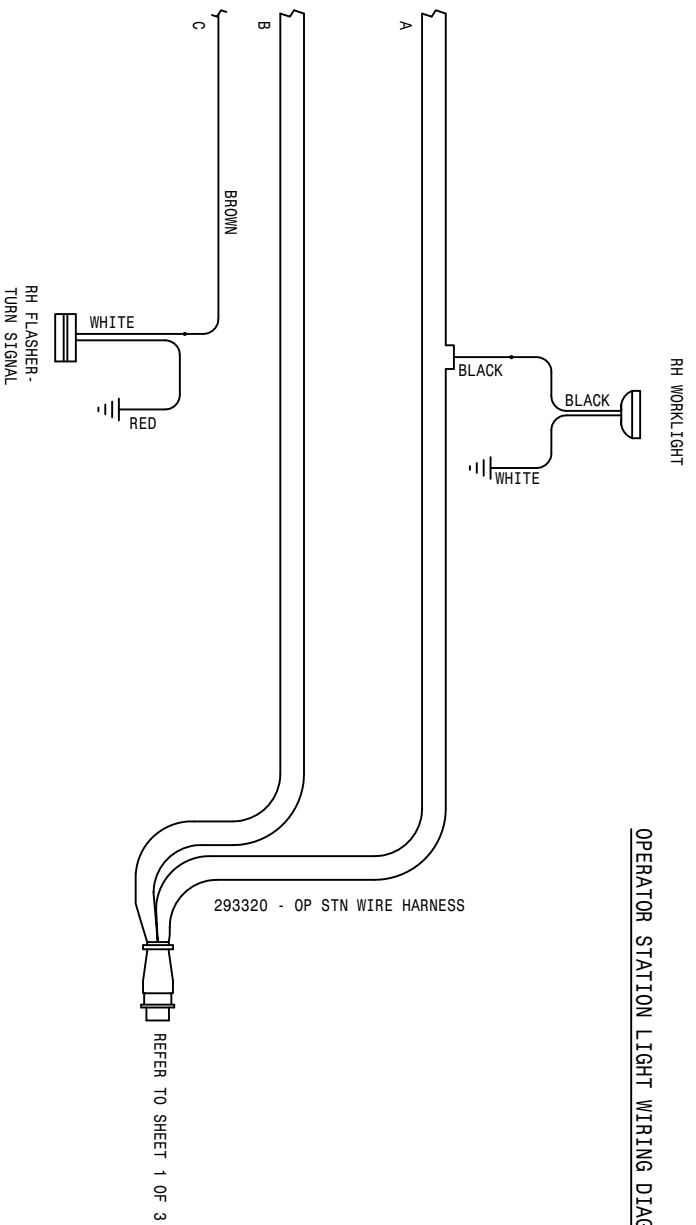

CANOPY LIGHT WIRING DIAGRAM

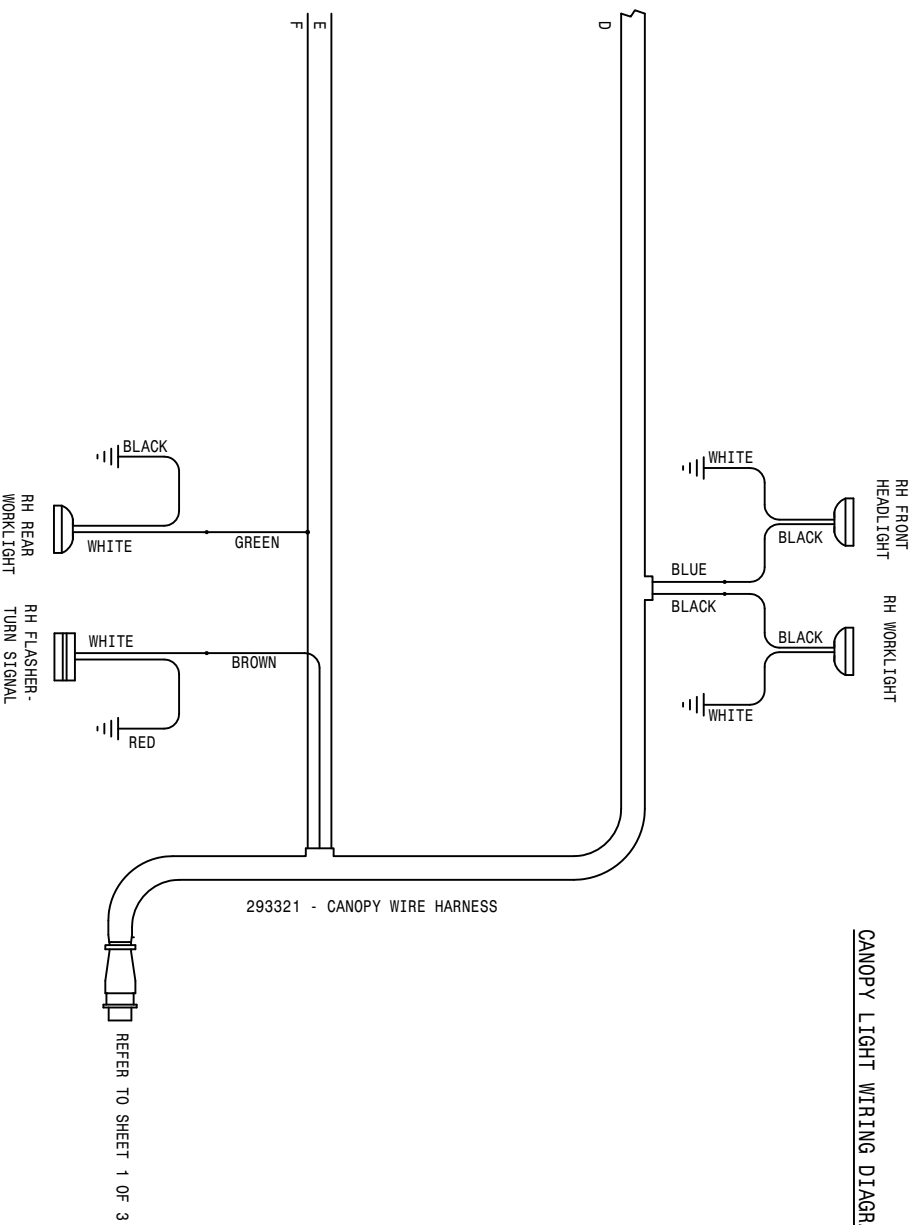

05-03-94 TUL
 204 CHR V WIRING DIAGRAM 94
 SHEET 2 OF 3
 REVISION DATE: 02-05-96
498447

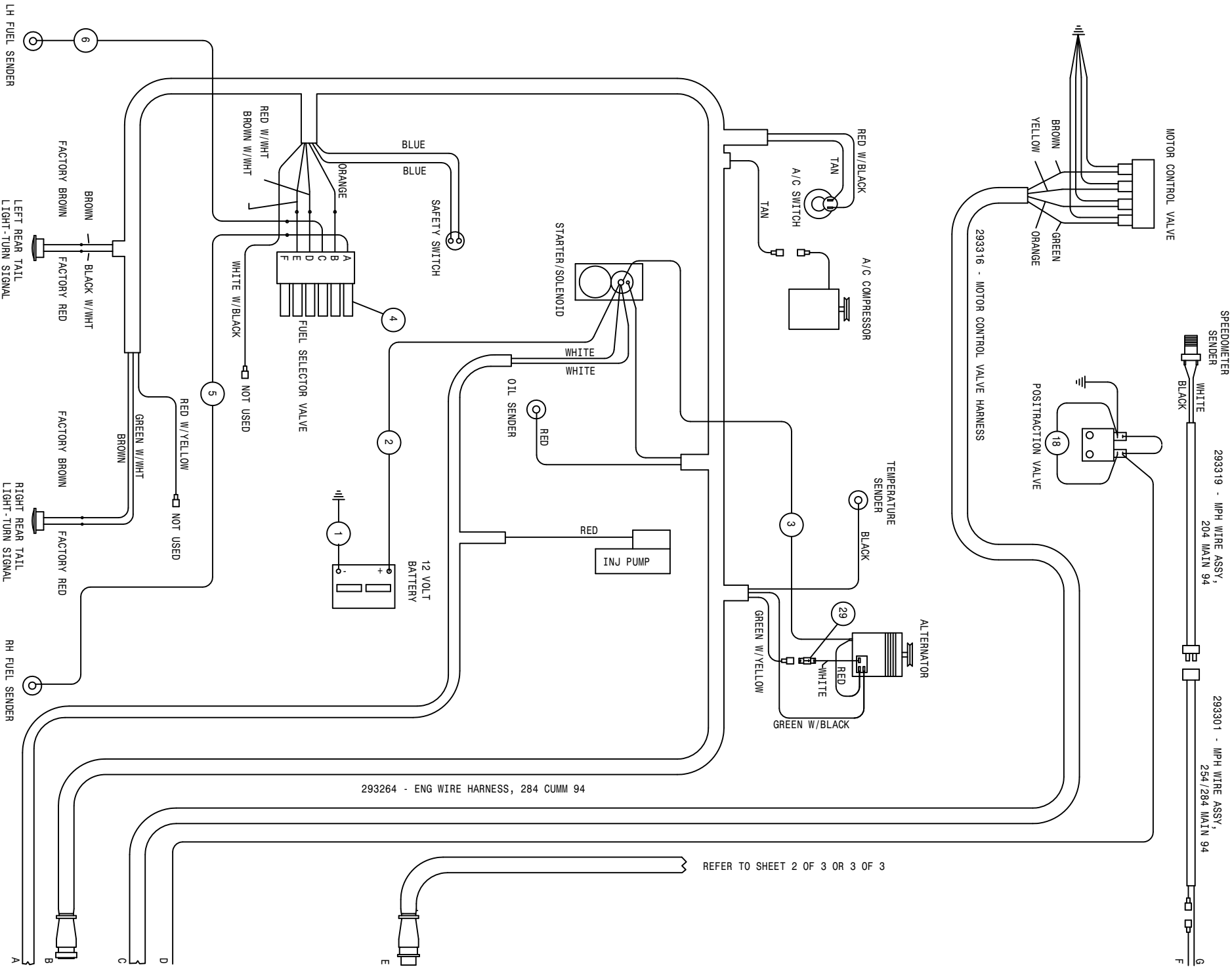

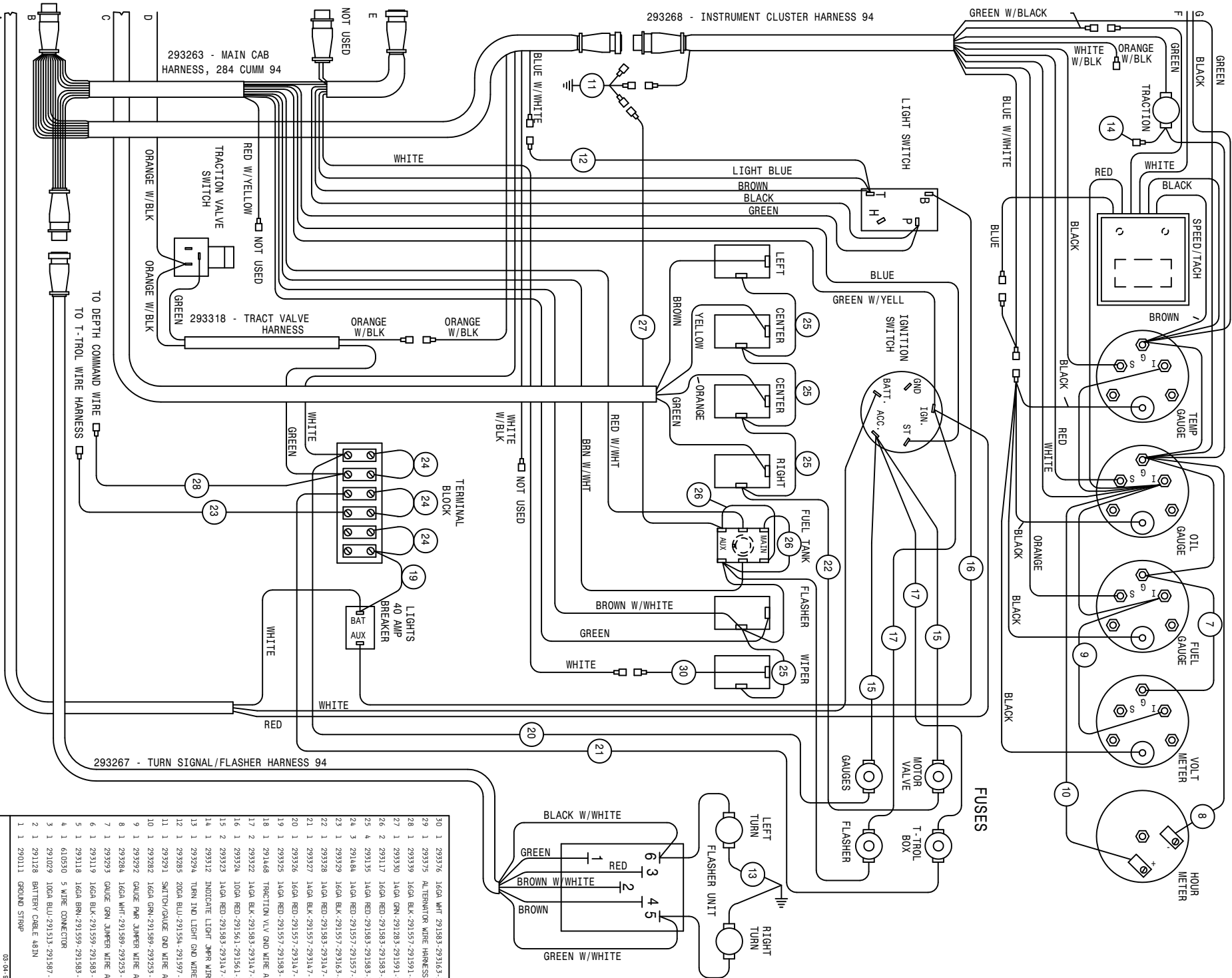

293268 - INSTRUMENT CLUSTER HARNESS 94

293263 - MAIN CAB HARNESS, 284 CUMM 94

293318 - TRACT VALVE HARNESS

293267 - TURN SIGNAL/FLASHER HARNESS 94

293265 - MAIN POWER HARNESS, 284 CUMM 94

30	1	293376	16GA WHT	291583-293163-3
29	1	293375	AL TERMINATOR WIRE HARNESS	DE:CD
28	1	293339	16GA BLK	291587-291591-40
27	1	293330	16GA GRN	291283-291591-20
26	2	293117	16GA RED	291583-291583-3
25	4	293135	16GA RED	291583-291583-3
24	3	291484	16GA RED	291587-291587-3
23	1	293329	16GA BK	291587-293163-44
22	1	293328	16GA RED	291583-293167-12
21	1	293327	16GA BK	291587-293167-12
20	1	293326	16GA RED	291587-293167-11
19	1	293325	16GA RED	291587-291583-10
18	1	291468	TRACTON VLV QND WIRE ASSY	88
17	2	293322	16GA BK	291583-293167-22
16	1	293324	10GA RED	291561-291561-31
15	2	293323	16GA RED	291583-293167-24
14	1	293312	INDICATE LIGHT 3MR WIRE ASSY	
13	1	293294	TURN IND LIGHT QND WIRE ASSY	
12	1	293285	200A BLU	291594-291597-16
11	1	293291	SWITCH/SWUCHE QND WIRE ASSY	
10	1	293282	16GA GRN	291589-293293-10
9	1	293292	GAUCHE PWR JUMPER WIRE ASSY	
8	1	293284	16GA WHT	291589-293293-10
7	1	293293	GAUCHE GRN JUMPER WIRE ASSY	
6	1	293319	16GA BLK	291599-291583-80
5	1	293318	16GA BRN	291599-291583-72
4	1	610030	5 WIRE CONNECTOR	
3	1	291029	100A BLU	291513-291587-30
2	1	291128	BATTERY CBL.E. 482N	
1	1	290111	GROUND STRAP	

204 CUMM WIRING DIAGRAM 94
 SHEET 1 OF 3
 REVISION DATE: 07-20-01
 498448
 05-04-94 TLM

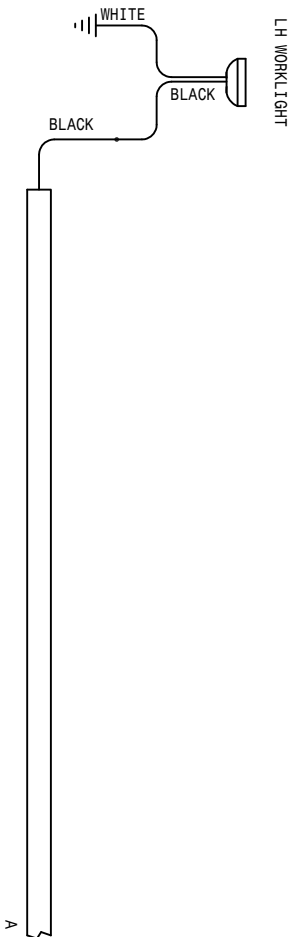
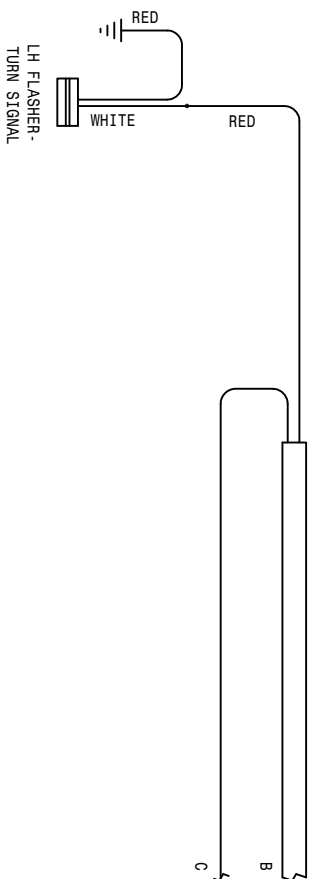
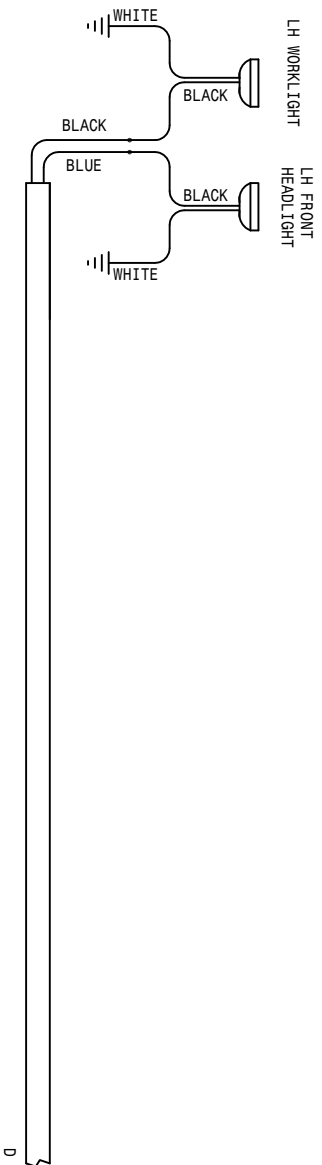
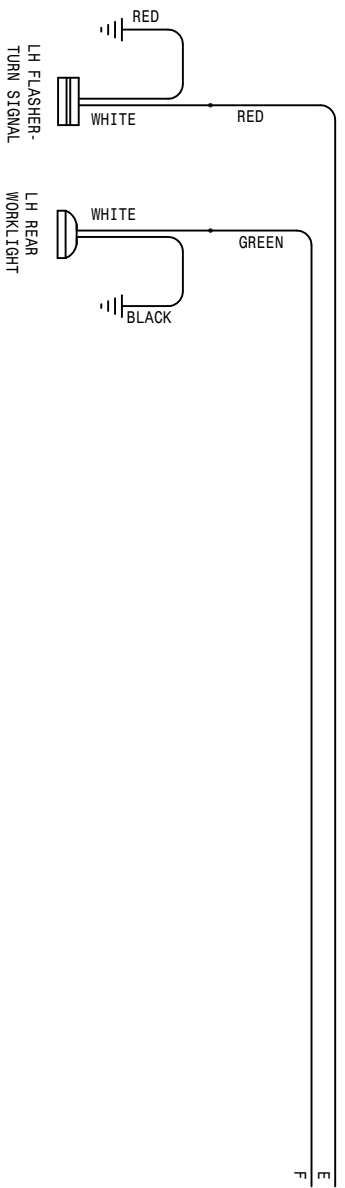

OPERATOR STATION LIGHT WIRING DIAGRAM

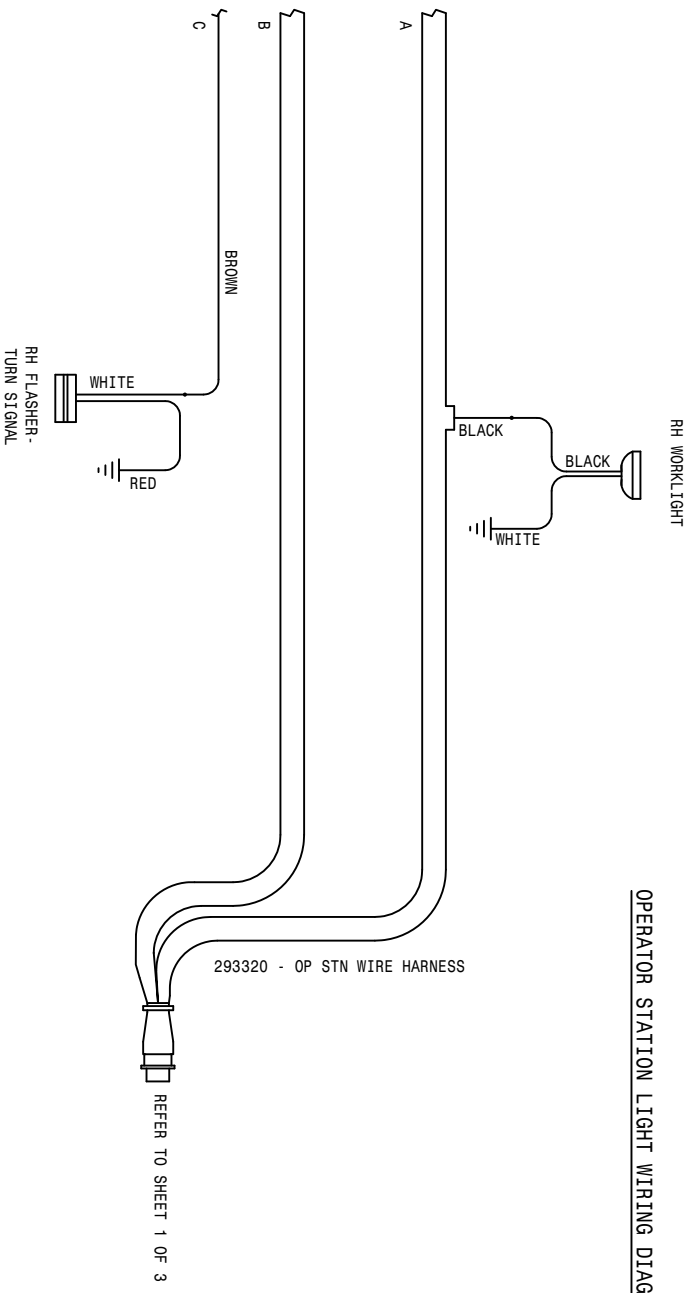

CANOPY LIGHT WIRING DIAGRAM

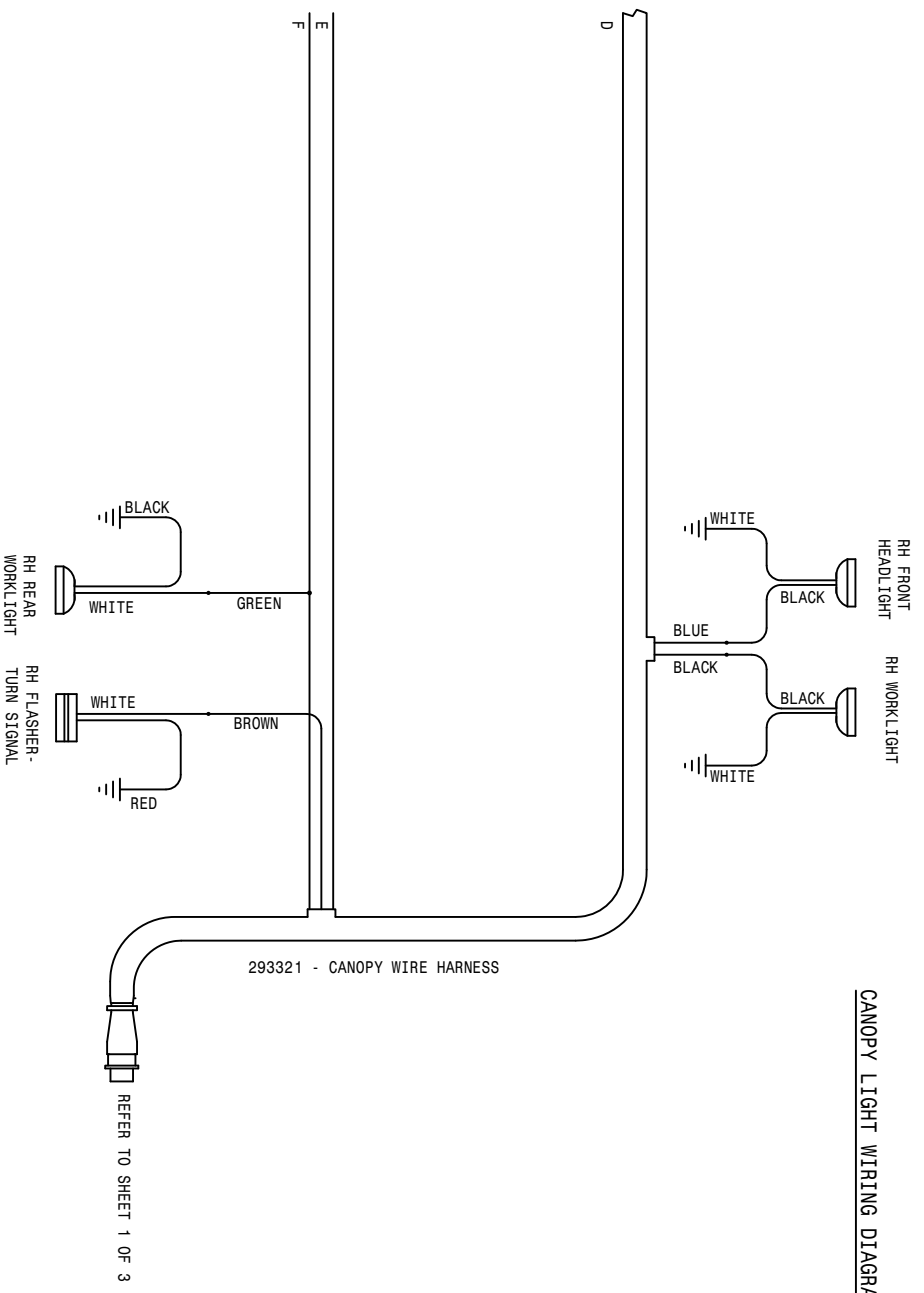

204 CUMM WIRING DIAGRAM 94
SHEET 2 OF 3
REVISION DATE: 02-05-98
498448
03-03-94 TUL

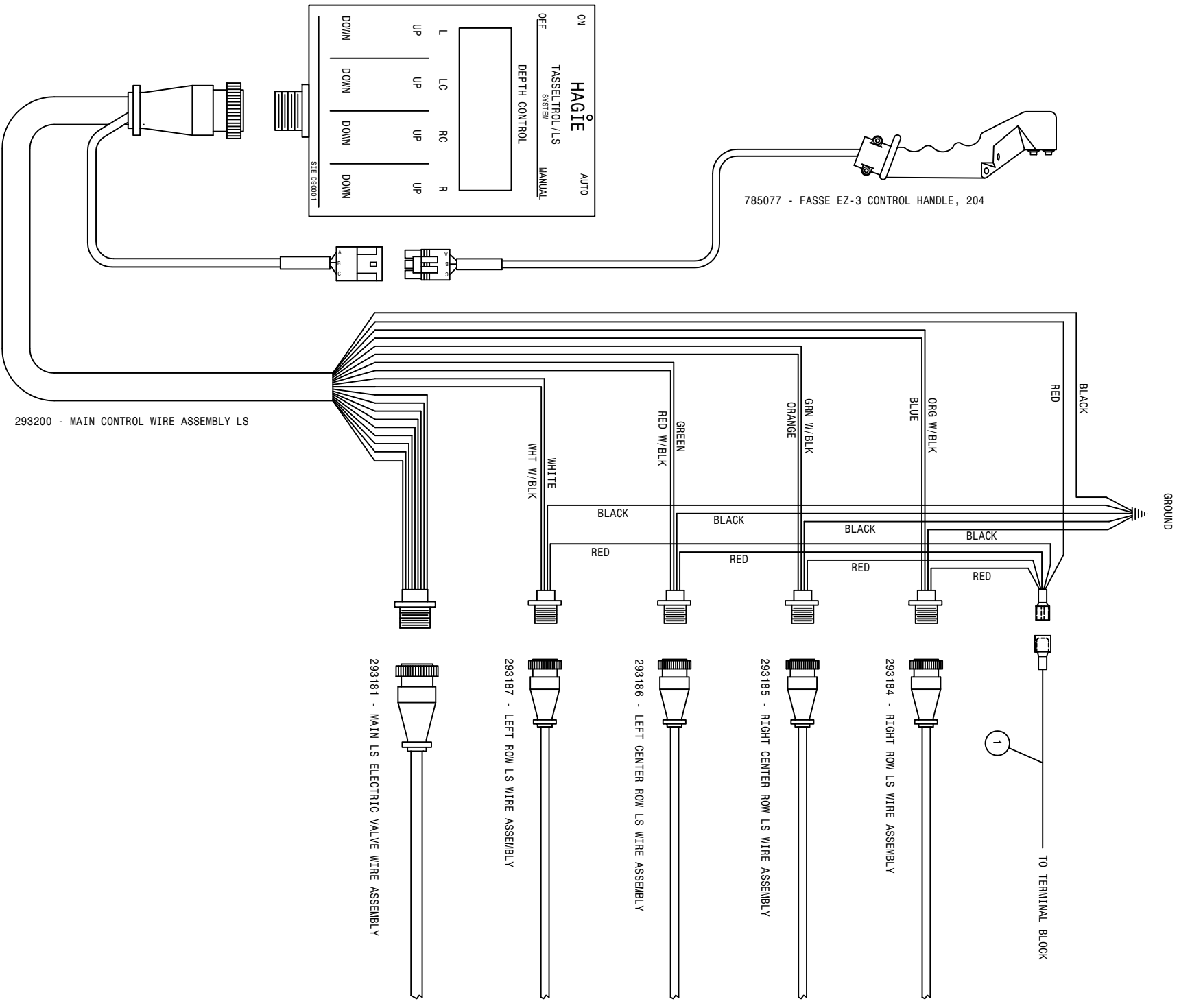

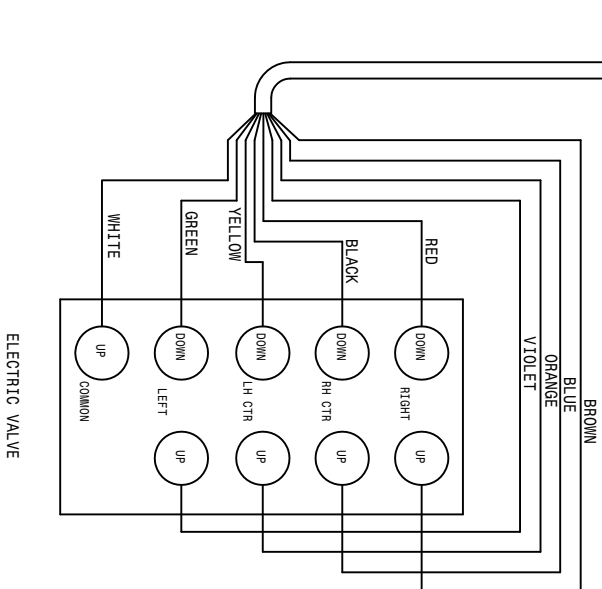
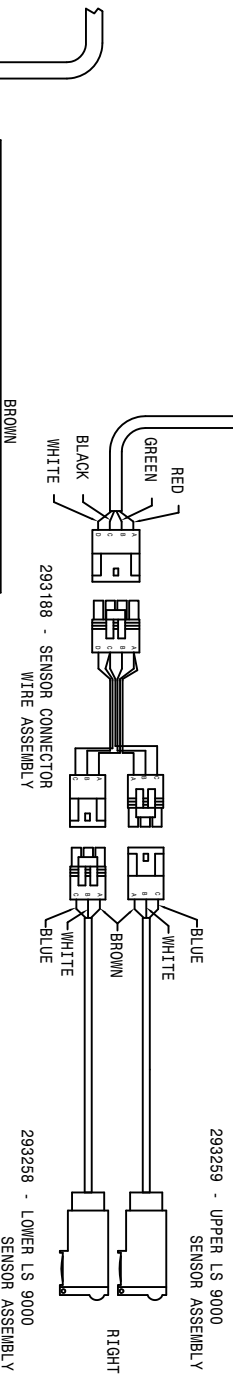
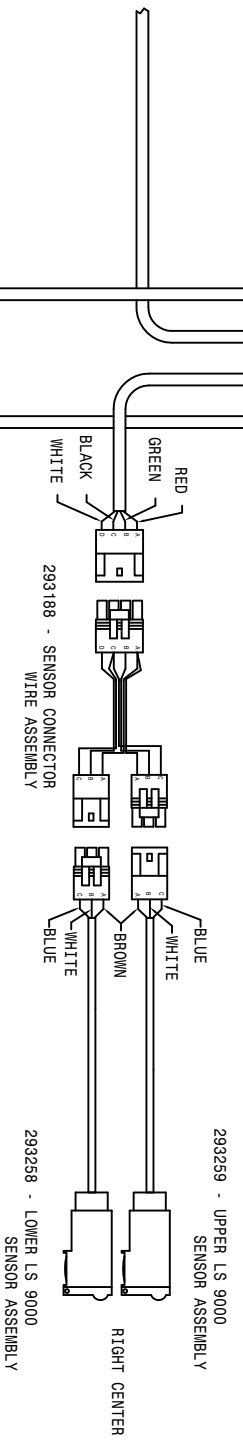
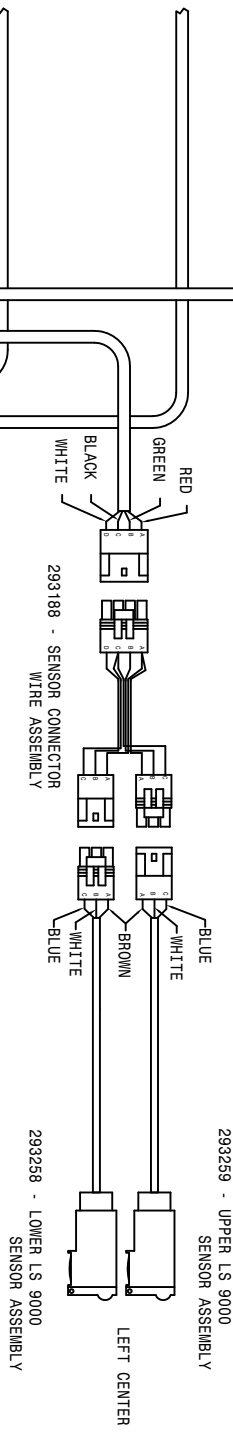
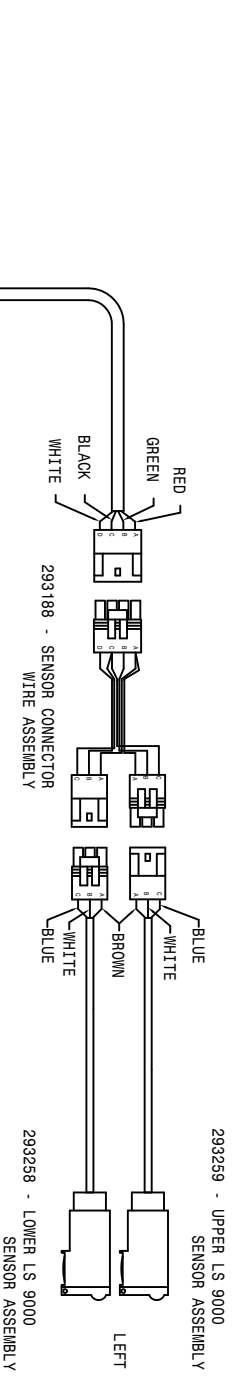

1	I	293259	16GA BLK-291557-293163-44	DESCRIPTION		
DEF	REV					
HAGIE						
HAGIE MANUFACTURING COMPANY						
CLARION, IOWA 50525						
REMOVE ALL SHARP CORNERS & BURRS						
TOLERANCE UNLESS OTHERWISE SPECIFIED						
FRACTION	:	DECIMALS	S	XXX	ANGLES	↑
1/32						
DESIGNATION		SCALE				
LS SYS WIRE DIA, 204 94		1/16"				
DRAWN BY		DATE				
T. J. BARKER		03-20-94				
CHECKED BY		COMP. NUMBER				
		498454				
SHEET	OF					

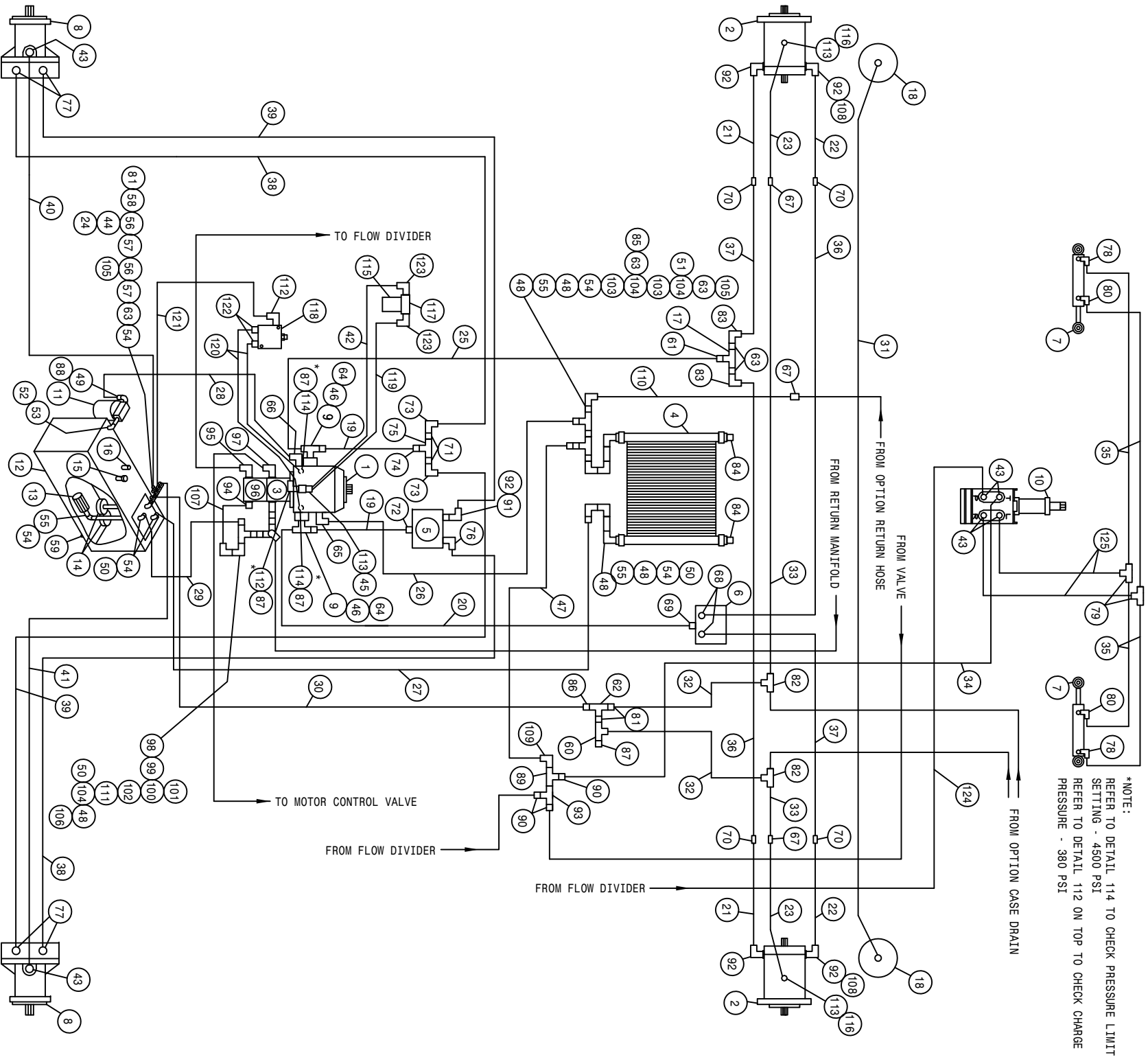

204 BASIC MACHINE CHRY HYD SCHEMATIC 1995
REFERENCE DRAWING NO. 498460

DET.	QTY	PART NO.	DESCRIPTION	DET.	QTY	PART NO.	DESCRIPTION
1	1	606911	SUND 75CC PUMP,B-MT W/FILT	64	2	618541	1 5/16FJIC-1 1/16MJIC ADPTR
2	2	610557	SUND M35-3102 WHL MTR W/SHFT	65	1	618118	3/4 HOSE BARB-90-1 1/16MOR
3	1	606894	SUND GEAR PUMP 3.40CI SPLINED	66	1	618564	1IN HOSE BARB-90-1 5/16MOR
4	1	618606	OIL COOLER, BLISSFIELD 65027	67	3	618314	3/4MJIC UNION
5	1	610468	POSITRACTION VLV MOD CONT 20G	68	2	618601	7/8MJIC-1 5/16MOR ADPT
6	1	610586	POSITRACTION VLV,ALUM,88SP60G	69	1	618186	1 5/16MJIC-1 5/16MOR ADPTR
7	2	620080	STRG CYL ASSY 1.50 X 6.0 1985	70	4	618553	1 1/16MJIC-7/8MJIC REDU UNION
8	2	610567	SUND M25-3000 WHL MTR 1.5CI	71	2	505005	RED BUSH 1 TO 1/2
9	2	618598	1" 4-BOLT FLG X 1 5/16 FOR	72	1	618308	1 1/16MJIC-1 5/16MOR ADPTR
10	1	749150	STRG MTR NON-LOAD REACT 1008	73	2	611124	7/8MJIC-90-1/2MNP LBO
11	1	605601	GRESEN FILTER 10 MICRON 40GPM	74	1	618434	1 1/16MJIC-1MNP ADPTR
12	1	760097	OIL TANK WLD 8240 1982	75	1	618575	1FNP PIPE TEE STL
13	1	605600	MICHIGAN RESERVOIR FILTER	76	1	618589	7/8MJIC-90-1 5/16MOR LBO
14	2	605603	LINE SUMP DIFFUSER	77	4	611126	7/8MJIC-7/8MOR ADPTR
15	1	611052	FILLER BREATHER 3/4NPT	78	2	618338	9/16MJIC-45-1/4MNP LBO
16	1	614453	DIPSTICK, 8IN	79	2	618019	9/16MJIC UNION TEE
17	1	614660	1IN STL TEE WLD 280	80	2	611122	9/16MJIC-90-1/4MNP LBO
18	2	620570	HYD CYL LEG LEVEL 2.00 X 12	81	3	618018	9/16MJIC-1/2MNP ADPTR
19	2	614672	HYD TUBE ASSY, SUND PUMP 200	82	2	610193	9/16MJIC BLKHD BRANCH TEE
20	1	614697	HYD TUBE ASSY, RH MAIN 200 91	83	2	618156	7/8MJIC-90-3/4MNP LBO
21	2	615659	FRT LEG INNER HYD TUBE,204 94	84	2	505102	PIPE PLUG 1.00NPT SQ HD
22	2	615660	FRT LEG CNTR HYD TUBE,204 94	85	1	610300	3/4MJIC-3/4MNP ADPTR
23	2	615661	FRT LEG OUTER HYD TUBE,204 94	86	1	611147	3/4MJIC-1/2MNP ADPTR
24	1	618520	1/4MNP RUN TEE-9/16MJIC	87	4	618531	9/16FJIC CAP NJT
25	1	614676	HYD TUBE ASSY, LH MAIN 200	88	1	506410	BLK PIPE ST EL 90DEG 1.25NPT
26	1	601395	HOSE, 3/4 X 64 1FBR-1SPI	89	1	618311	3/4MJIC UNION TEE
27	1	601396	HOSE, 1 X 81 1FBR-1SPI	90	3	618482	3/4FJIC-9/16MJIC ADPTR
28	1	601376	HOSE, 1 X 29 1FBR-1SPI	91	1	618312	1 5/16MOR-1 1/16FOR ADPTR
29	1	601377	HOSE, 1 X 48 1FBR-1SPI	92	5	618535	7/8MJIC-90-1 1/16MOR LBO
30	1	614388	08C1T-08FJX-08FJX-129	93	1	618451	3/4FJIC SW RUN TEE-3/4MJIC
31	1	615614	FRT LEG CYL JUMPER HOSE280 89	94	1	618075	3/4 HOSE BARB-1 1/16MOR
32	2	614625	06C1T-06FJX-06FJX-30	95	1	611128	7/8MJIC-90-7/8MOR LBO
33	2	615451	06C1T-06FJX-08FJX-58	96	1	606891	SUND GEAR PMP .52CI SPLINED
34	1	611204	04C1T-06FJX-06FJX-78	97	1	618178	1 5/16MJIC-90-1 5/16MOR LBO
35	4	614663	04C1T-06FJX-06FJX-16	98	1	618596	1 5/8MOR-1 1/4FNPT ADPTR
36	2	614655	08C2AT-10FJX-12FJX90-70	99	1	507026	1 1/4MNP HEX PIPE NIPPLE STL
37	2	614654	08C2AT-10FJX-12FJX90-60	100	1	506701	SIDE OUTLET EL 90DEG 1.25NPT
38	2	614656	08C2AT-10FJX-10FJX-118	101	1	715660	HOSE BARB 1 1/4NPT X 1 1/4
39	2	614657	08C2AT-10FJX-10FJX-125	102	1	506005	1 1/4 TO 1 RED BUSH BLK MAL
40	1	615449	06C1T-06FJX-06FJX-140	103	2	505201	CLOSE NIPPLE 1.00NPT
41	1	615449	06C1T-06FJX-06FJX-126	104	3	505101	BLK PIPE TEE 1.00NPT
42	1	615633	08C1T-08FJX-08FJX-23	105	2	610305	3/4MJIC-90-3/4MNP LBO
43	6	618496	9/16MJIC-45-3/4MOR LBO	106	1	716000	3/4 HOSE BARB-90-1MNP
44	1	504001	RED BUSH 3/4 X 1/4 BLK MAL	107	1	601383	HOSE, 3/4 X 8 1FBR-1SPI
45	1	618183	3/4MJIC-90-7/8MOR LBO	108	2	618628	7/8MJIC-45-7/8FJIC SWIV LBO
46	2	618599	1 5/16MOR BRANCH TEE-1 5/16MJ	109	1	618609	3/4MJIC-90-3/4FJIC SWIV LBO
47	1	615465	08C1T-08FJX-08FJX-33	110	1	614662	08C1T-08FJX-08FJX-72
48	5	505200	BLK PIPE ST EL 90DEG 1.00NPT	111	1	505105	1MNP HEX PIPE NIPPLE STL
49	1	715664	1 1/4 NPT X 1 HOSE BARB	112	2	618119	9/16MJIC-90-9/16MOR LBO
50	4	714560	1NPT X 1 HOSE BARB	113	3	618327	3/4MJIC-7/8MOR ADPTR
51	1	714331	1 NPT X 3/4 HOSE BARB	114	2	618629	9/16MOR BRANCH TEE-9/16MJIC
52	1	506602	PIPE NIPPLE 1 1/4NPT-2 1/2	115	1	605607	FILTER, 10 MICRON ZINGA,HIPRES
53	1	506303	BLK PIPE EL 90DEG 1.25NPT	116	2	618590	3/4MJIC-45-3/4FJIC SWIV LBO
54	6	505300	BLK PIPE EL 90DEG 1.00NPT	117	1	605606	FILTER HEAD, ZINZA HI-PRESS
55	3	505203	BLK PIPE NIPPLE 1.00NPT-4.00	118	1	610580	REMOTE FLUSHING VALVE, SUND
56	2	504955	BLK PIPE TEE .75NPT	119	1	616034	08C1T-08FJX-08FJX-17
57	2	504702	CLOSE NIPPLE .75NPT	120	2	616043	04C1T-06FJX-06FJX-23
58	1	504210	RED BUSH 3/4 NPT X 1/2 NPT	121	1	616048	04C1T-06FJX-06FJX-35
59	1	501102	1/4 PIPE PLUG	122	2	618126	9/16MJIC-9/16MOR ADPTR
60	1	618486	9/16FJIC SW RUN TEE-9/16MJIC	123	2	618474	3/4MJIC-90-1 1/16MOR LBO
61	1	618322	1 5/16MJIC-1MNP ADPTR	124	1	616040	04C1T-06FJX-06FJX-67
62	1	503820	BLK PIPE TEE .50NPT	125	2	616028	04C1T-06FJX-06FJX-47
63	5	505213	RED BUSH 1 X 3/4 BLK MAL				

204 BASIC MACHINE CUMM HYD SCHEMATIC 1995
REFERENCE DRAWING NO. 498461

DET.	QTY	PART NO.	DESCRIPTION	DET.	QTY	PART NO.	DESCRIPTION
1	1	606911	SUND 75CC PUMP,B-MT W/FILT	64	2	618541	1 5/16FJIC-1 1/16MJIC ADPTR
2	2	610557	SUND M35-3102 WHL MTR W/SHFT	65	1	618118	3/4 HOSE BARB-90-1 1/16MOR
3	1	606894	SUND GEAR PUMP 3.40CI SPLINED	66	1	618564	1IN HOSE BARB-90-1 5/16MOR
4	1	618606	OIL COOLER, BLISSFIELD 65027	67	3	618314	3/4MJIC UNION
5	1	610468	POSTRACTION VLV MOD CONT 20G	68	2	618601	7/8MJIC-1 5/16MOR ADPT
6	1	610586	POSTRACTION VLV,ALUM,88SP60G	69	1	618186	1 5/16MJIC-1 5/16MOR ADPTR
7	2	620080	STRG CYL ASSY 1.50 X 6.0 1985	70	4	618553	1 1/16MJIC-7/8MJIC REDU UNION
8	2	610567	SUND M25-3000 WHL MTR 1.5CI	71	2	505005	RED BUSH 1 TO 1/2
9	2	618598	1" 4-BOLT FLG X 1 5/16 FOR	72	1	618308	1 1/16MJIC-1 5/16MOR ADPTR
10	1	749150	STRG MTR NON-LOAD REACT 1008	73	2	611124	7/8MJIC-90-1/2MNP LBO
11	1	605601	GRESEN FILTER 10 MICRON 40GPM	74	1	618434	1 1/16MJIC-1MNP ADPTR
12	1	760097	OIL TANK WLD 8240 1982	75	1	618575	1FNPT PIPE TEE STL
13	1	605600	MICHIGAN RESERVOIR FILTER	76	1	618589	7/8MJIC-90-1 5/16MOR LBO
14	2	605603	LINE SUMP DIFUSER	77	4	611126	7/8MJIC-7/8MOR ADPTR
15	1	611052	FILLER BREATHER 3/4ANPT	78	2	618338	9/16MJIC-45-1/4MNP LBO
16	1	614453	DIPSTICK, 81N	79	2	618019	9/16MJIC UNION TEE
17	1	614660	1IN STL TEE WLD 280	80	2	611122	9/16MJIC-90-1/4MNP LBO
18	2	620570	HYD CYL LEG LEVEL 2.00 X 12	81	2	618018	9/16MJIC-1/2MNP ADPTR
19	2	614707	HYD TUBE ASSY,SUND,200 DIESEL	82	3	610193	9/16MJIC BLKHD BRANCH TEE
20	2	615634	12TMM-16FJX-16FJX-123	83	2	618156	7/8MJIC-90-3/4MNP LBO
21	2	615659	FRT LEG INNER HYD TUBE,204 94	84	2	505102	PIPE PLUG 1.00NPT SQ HD
22	2	615660	FRT LEG CNTR HYD TUBE,204 94	85	1	610300	3/4MJIC-3/4MNP ADPTR
23	2	615661	FRT LEG OUTER HYD TUBE,204 94	86	1	611147	3/4MJIC-1/2MNP ADPTR
24	1	618520	1/4MNP RUN TEE-9/16MJIC	87	4	618531	9/16FJIC CAP NUT
25	2	618191	1 1/16MJ-90-1 1/16FJ SWIV LBO	88	1	506410	BLK PIPE ST EL 90DEG 1.25NPT
26	1	601110	HOSE, 3/4 X 64 2BR RED	89	1	618311	3/4MJIC UNION TEE
27	1	601314	HOSE, 1 X 81 2 BR RED	90	3	618482	3/4FJIC-9/16MJIC ADPTR
28	1	601376	HOSE, 1 X 29 1FBR-1SPI	91	1	618312	1 5/16MOR-1 1/16FOR ADPTR
29	1	601377	HOSE, 1 X 48 1FBR-1SPI	92	5	618535	7/8MJIC-90-1 1/16MOR LBO
30	1	614388	08C1T-08FJX-08FJX-129	93	1	618451	3/4FJIC SW RUN TEE-3/4MJIC
31	1	615614	FRT LEG CYL JUMPER HOSE280 89	94	1	618075	3/4 HOSE BARB-1 1/16MOR
32	2	614625	06C1T-06FJX-06FJX-30	95	1	611128	7/8MJIC-90-7/8MOR LBO
33	2	615451	06C1T-06FJX-08FJX-58	96	1	606891	SUND GEAR PMP .52CI SPLINED
34	1	611204	04C1T-06FJX-06FJX-78	97	1	618178	1 5/16MJIC-90-1 5/16MOR LBO
35	4	614663	04C1T-06FJX-06FJX-16	98	1	618596	1 5/8MOR-1 1/4FNPT ADPTR
36	2	614655	08C2AT-10FJX-12FJX90-70	99	1	507026	1 1/4MNP HEX PIPE NIPPLE STL
37	2	614654	08C2AT-10FJX-12FJX90-60	100	1	506701	SIDE OUTLET EL 90DEG 1.25NPT
38	2	614656	08C2AT-10FJX-10FJX-118	101	1	715660	HOSE BARB 1 1/4NPT X 1 1/4
39	2	614657	08C2AT-10FJX-10FJX-125	102	2	506005	1 1/4 TO 1 RED BUSH BLK MAL
40	1	614549	06C1T-06FJX-06FJX-140	103	2	505201	CLOSE NIPPLE 1.00NPT
41	1	615449	06C1T-06FJX-06FJX-126	104	3	505101	BLK PIPE TEE 1.00NPT
42	1	615633	08C1T-08FJX-08FJX-23	105	2	610305	3/4MJIC-90-3/4MNP LBO
43	6	618496	9/16MJIC-45-3/4MOR LBO	106	1	716000	3/4 HOSE BARB-90-1MNP
44	1	504001	RED BUSH 3/4 X 1/4 BLK MAL	107	1	601311	HOSE, 3/4 X 8 2BR RED
45	1	618183	3/4MJIC-90-7/8MOR LBO	108	2	618628	7/8MJIC-45-7/8FJIC SWIV LBO
46	2	618599	1 5/16MOR BRANCH TEE-1 5/16MJ	109	1	618609	3/4MJIC-90-3/4FJIC SWIV LBO
47	1	615465	08C1T-08FJX-08FJX-33	110	1	614662	08C1T-08FJX-08FJX-72
48	5	505200	BLK PIPE ST EL 90DEG 1.00NPT	111	1	505105	1MNP HEX PIPE NIPPLE STL
49	1	715664	1 1/4 NPT X 1 HOSE BARB	112	2	618119	9/16MJIC-90-9/16MOR LBO
50	4	714560	1NPT X 1 HOSE BARB	113	3	618327	3/4MJIC-7/8MOR ADPTR
51	1	714331	1 NPT X 3/4 HOSE BARB	114	2	618629	9/16MOR BRANCH TEE-9/16MJIC
52	1	506602	PIPE NIPPLE 1 1/4NPT-2 1/2	115	1	605607	FILTER,10 MICRON ZINGA,HIPRES
53	1	506303	BLK PIPE EL 90DEG 1.25NPT	116	2	618590	3/4MJIC-45-3/4FJIC SWIV LBO
54	6	505300	BLK PIPE EL 90DEG 1.00NPT	117	1	605606	FILTER HEAD, ZINZA HI-PRESS
55	3	505203	BLK PIPE NIPPLE 1.00NPT-4.00	118	1	610580	REMOTE FLUSHING VALVE, SUND
56	2	504955	BLK PIPE TEE .75NPT	119	1	616034	08C1T-08FJX-08FJX-17
57	2	504702	CLOSE NIPPLE .75NPT	120	2	616043	04C1T-06FJX-06FJX-23
58	1	504210	RED BUSH 3/4 NPT X 1/2 NPT	121	1	616048	04C1T-06FJX-06FJX-35
59	1	501102	1/4 PIPE PLUG	122	2	618126	9/16MJIC-9/16MOR ADPTR
60	2	618486	9/16FJIC SW RUN TEE-9/16MJIC	123	2	618474	3/4MJIC-90-1 1/16MOR LBO
61	1	618322	1 5/16MJIC-1MNP ADPTR	124	1	616040	04C1T-06FJX-06FJX-67
62	1	503820	BLK PIPE TEE .50NPT	125	2	616028	04C1T-06FJX-06FJX-47
63	5	505213	RED BUSH 1 X 3/4 BLK MAL				

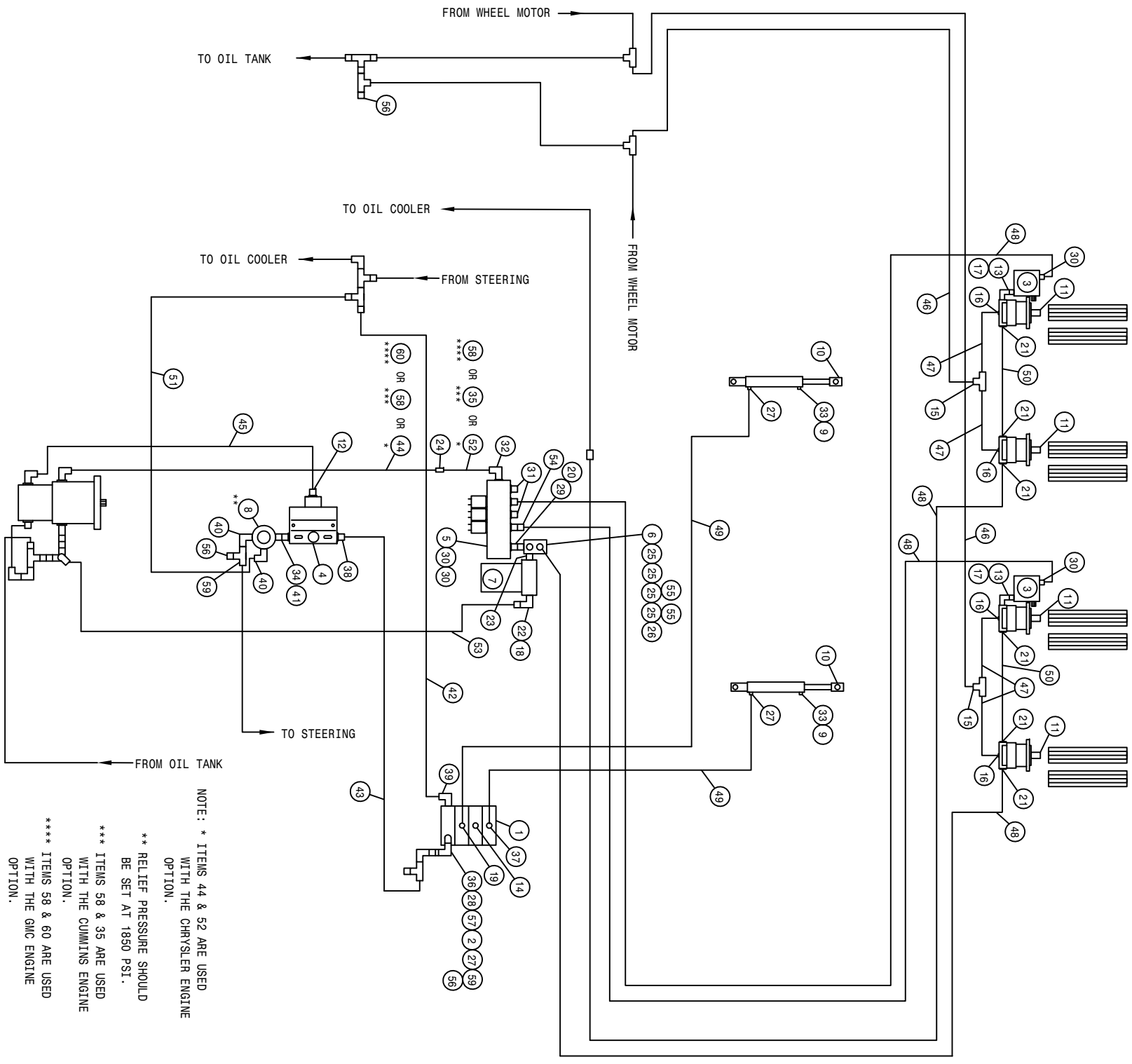

200 4R ROLLER 2L W/T-TROL HYD SCHEM 91
REFERENCE DRAWING NO. 498373

DET.	QTY	PART NO.	DESCRIPTION	DET.	QTY	PART NO.	DESCRIPTION
1	1	610532	ELECT HYD STACK VLV, 3 SECT	31	2	610186	1 1/16MOR PLUG
2	1	610447	HYD FILTER, INLINE 1/4FNPT 90M	32	1	618178	1 5/16MJIC-90-1 5/16MOR LBO
3	2	610528	PRESS COMP FIXED FLO REG 11G	33	2	501452	ST EL 90DEG .25NPT, STEEL,PLT
*4	1	607504	FLO DIV B50 2-8GPM 7/8 FOR	*34	1	500000	1/2MNPT HEX PIPE NIPPLE STL
5	1	610467	MODULAR MTR CONTROL ELECT VLV	*35	1	614703	HYD TUBE ASSY, 200 MAIN 92
*6	1	614633	HYD MANIF 8200 86	36	1	618170	3/4MOR-9/16FOR ADPTR
*7	1	605601	GRESEN FILTER 10 MICRON 40GPM	37	1	618119	9/16MJIC-90-9/16MOR LBO
*8	1	607512	RELIEF VALVE, RL50, 1850 PSI	*38	1	618310	9/16MJIC-7/8MOR ADPTR
9	2	470114	BREATHER FILTER VENT, 1/4 NPT	39	1	618600	9/16MJIC-90-7/8MOR LBO
10	2	620900	CYL ASSY CC2016 D00 SRG 180	*40	2	618107	9/16MJIC-90-1/2MNPT LBO
11	4	610510	CESSNA GEAR MOTOR 1.48CI	*41	1	618072	7/8MOR-1/2FNPT ADPTR
*12	1	611126	7/8MJIC-7/8MOR ADPTR	*42	1	614627	06C1T-06FJX-06FJX-45
13	2	618578	1 1/16FJIC SWIV-1 1/16MOR	*43	1	615616	04C1T-06FJX-06FJX-65
14	1	610185	9/16MOR PLUG	*44	1	614687	HYD TUBE ASSY SUND AUX 200 90
15	2	618019	9/16MJIC UNION TEE	*45	1	614664	10C1T-10FJX-10FJX-98
16	4	611121	9/16MJIC-1/4MNPT ADPTR	46	2	614639	04C1T-06FJX-06FJX-126
17	2	618248	1 1/16MJIC-90-1 1/16MOR LBO	47	4	616027	04C1T-06FJX-06FJX-39
*18	1	715660	HOSE BARB 1 1/4NPT X 1 1/4	48	4	614689	08C1T-08FJX-08FJX-120
19	1	618425	9/16MJIC-45-9/16MOR LBO	49	2	614101	04C1T-06FJX-06FJX-133
*20	1	618587	1 5/16FJIC SWIV-1MNPT	50	2	616058	08C1T-08FJX-08FJX-80
21	6	618474	3/4MJIC-90-1 1/16MOR LBO	*51	1	616042	04C1T-06FJX-06FJX-13
*22	1	506410	BLK PIPE ST EL 90DEG 1.25NPT	*52	1	614348	16C2AT-16FJX-16FJX-25
*23	1	618144	1 1/4-1MP HEX PIPE NIPPLE STL	*53	1	601289	HOSE, 1 1/4 X 144 2BR RED
*24	1	618577	1 5/16MJIC UNION	54	1	618590	3/4MJIC-45-3/4FJIC SWIV LBO
*25	4	611145	3/4MJIC-90-1/2MNPT LBO	*55	2	618532	3/4FJIC CAP NUT
*26	1	503700	PIPE PLUG .50NPT SQ HD	*56	3	618531	9/16FJIC CAP NUT
27	3	611122	9/16MJIC-90-1/4MNPT LBO	57	1	618608	9/16FJIC SWIV-1/4MNPT
28	1	618440	9/16MJIC-90-9/16MOR EX LG LBO	*58	1	614350	16C2AT-16FJX-16FJX-55
29	1	618186	1 5/16MJIC-1 5/16MOR ADPTR	*59	2	618486	9/16FJIC SW RUN TEE-9/16MJIC
30	4	618469	3/4MJIC-1 1/16MOR ADPTR	*60	1	614719	HYD TUBE ASSY, AUX 204 GMC 96

200 6R ROLLER 3L W/T-TROL HYD SCHEM 91
REFERENCE DRAWING NO. 498375

DET.	QTY	PART NO.	DESCRIPTION	DET.	QTY	PART NO.	DESCRIPTION
1	1	610532	ELECT HYD STACK VLV, 3 SECT	33	3	501452	ST EL 90DEG .25NPT, STEEL,PLT
2	1	610447	HYD FILTER, INLINE 1/4FNPT 90M	*34	1	500000	1/2MNP HEX PIPE NIPPLE STL
3	3	610528	PRESS COMP FIXED FLO REG 11G	*35	1	614350	16G2AT-16FJX-16FJX-55 H/A
*4	1	607504	FLO DIV B50 2-8GPM 7/8 FOR	36	4	611122	9/16MJIC-90-1/4MNP LBO
5	1	610467	MODULAR MTR CONTROL ELECT VLV	37	1	618440	9/16MJIC-90-9/16MOR EX LG LBO
*6	1	614653	HYD MANIF 8200 86	*38	1	618310	9/16MJIC-7/8MOR ADPTR
*7	1	605601	GRESEN FILTER 10 MICRON 40GPM	39	1	618170	3/4MOR-9/16FOR ADPTR
*8	1	607512	RELIEF VALVE, RL50, 1850 PSI	*40	2	618107	9/16MJIC-90-1/2MNP LBO
9	3	470114	BREATHER FILTER VENT, 1/4 NPT	*41	1	618072	7/8MOR-1/2FNPT ADPTR
10	3	620900	CYL ASSY CC2016 D00 SRG 180	42	1	618600	9/16MJIC-90-7/8MOR LBO
11	6	610510	CESSNA GEAR MOTOR 1.48CI	43	2	618119	9/16MJIC-90-9/16MOR LBO
*12	1	611126	7/8MJIC-7/8MOR ADPTR	44	2	614688	08C1T-08FJX-08FJX-108 H/A
13	3	618578	1 1/16FJIC SWIV-1 1/16MOR	45	2	614101	04C1T-06FJX-06FJX-133 H/A
*14	1	618577	1 5/16MJIC UNION	46	2	614077	04C1T-06FJX-06FJX-88 H/A
15	1	610193	9/16MJIC BLKHD BRANCH TEE	47	2	611210	04C1T-06FJX-06FJX-156 H/A
16	3	618019	9/16MJIC UNION TEE	*48	1	601289	HOSE, 1 1/4 X 144 ZBR RED
17	3	618248	1 1/16MJIC-90-1 1/16MOR LBO	*49	1	614348	16G2AT-16FJX-16FJX-25 H/A
*18	1	715660	HOSE BARB 1 1/4NPT X 1 1/4	50	3	616058	08C1T-08FJX-08FJX-80 H/A
19	1	618425	9/16MJIC-45-9/16MOR LBO	51	4	614690	08C1T-08FJX-08FJX-192 H/A
*20	1	618587	1 5/16FJIC SWIV-1MNP	*52	1	616042	04C1T-06FJX-06FJX-13 H/A
21	6	611121	9/16MJIC-1/4MNP ADPTR	*53	1	614627	06C1T-06FJX-06FJX-45 H/A
*22	1	506410	BLK PIPE ST EL 90DEG 1.25NPT	*54	1	615616	04C1T-06FJX-06FJX-65 H/A
*23	1	618144	1 1/4-1MP HEX PIPE NIPPLE STL	*55	1	614687	HYD TUBE ASSY SUND AUX 200 90
*24	4	611145	3/4MJIC-90-1/2MNP LBO	*56	1	614664	10C1T-10FJX-10FJX-98 H/A
25	1	618590	3/4MJIC-45-3/4FJIC SWIV LBO	57	1	616026	04C1T-06FJX-06FJX-37 H/A
*26	1	503700	PIPE PLUG .50NPT SQ HD	58	6	616027	04C1T-06FJX-06FJX-39 H/A
*27	3	618531	9/16FJIC CAP NUT	*59	1	618532	3/4FJIC CAP NUT
28	9	618474	3/4MJIC-90-1 1/16MOR LBO	60	1	618608	9/16FJIC SWIV-1/4MNP
29	1	618186	1 5/16MJIC-1 5/16MOR ADPTR	*61	1	614703	HYD TUBE ASSY, 200 MATN 92
30	6	618469	3/4MJIC-1 1/16MOR ADPTR	*62	2	618486	9/16FJIC SW RUN TEE-9/16MJIC
31	1	610186	1 1/16MOR PLUG	*63	1	614719	HYD TUBE ASSY, AUX 204 GMC 96
32	1	618178	1 5/16MJIC-90-1 5/16MOR LBO				

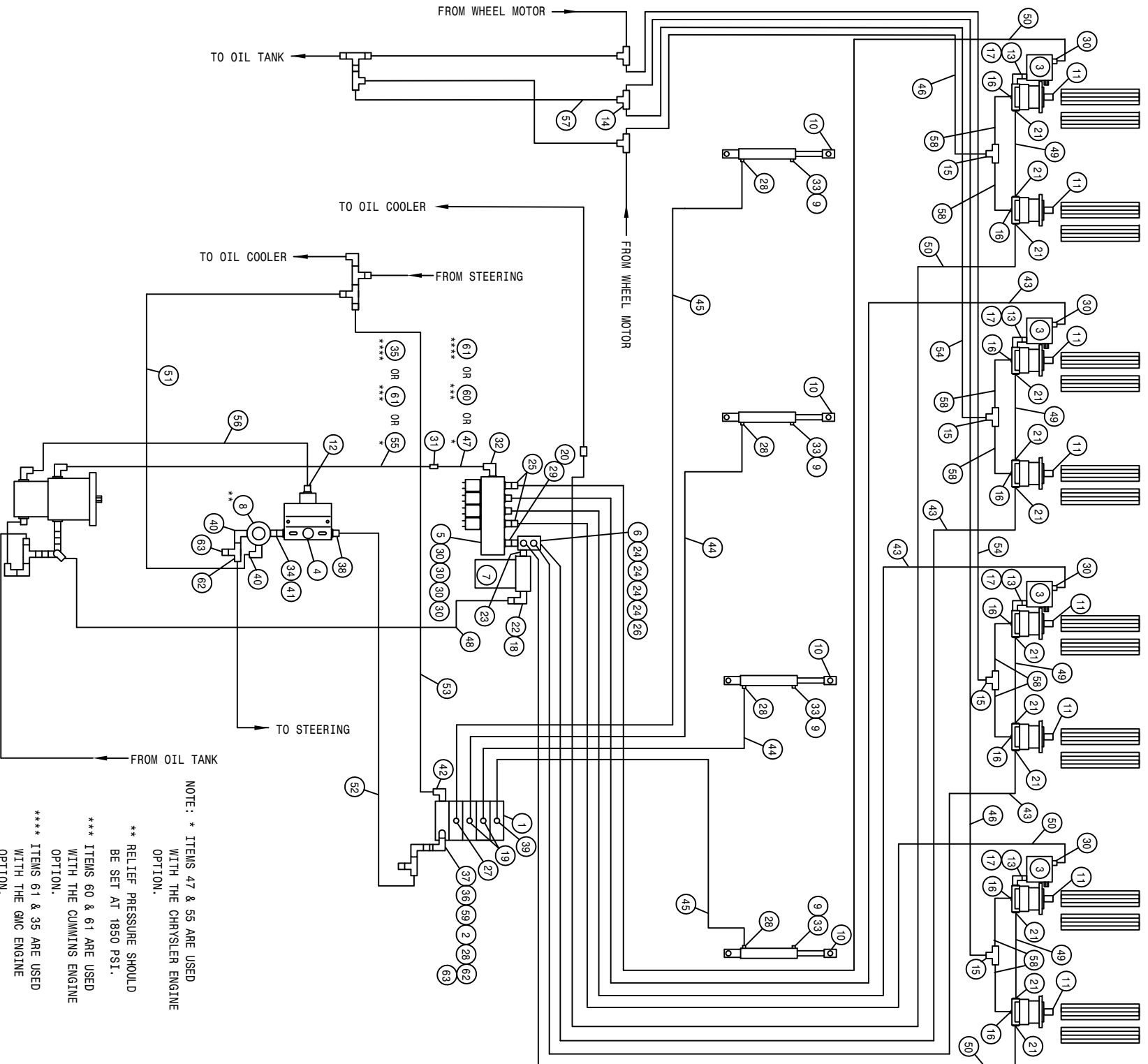

NOTE: * ITEMS 47 & 55 ARE USED WITH THE CHRYSLER ENGINE OPTION.
 ** RELIEF PRESSURE SHOULD BE SET AT 1850 PSI.
 *** ITEMS 60 & 61 ARE USED WITH THE CUMMINS ENGINE OPTION.
 **** ITEMS 61 & 35 ARE USED WITH THE GMC ENGINE OPTION.

200 8R ROLLER 4L W/T-TROL HYD SCHEM 91
REFERENCE DRAWING NO. 498376

DET.	QTY	PART NO.	DESCRIPTION	DET.	QTY	PART NO.	DESCRIPTION
1	1	610613	ELECT HYD STACT VLV, 4 SECT	33	4	501452	ST EL 90DEG .25NPT, STEEL,PLT
2	1	610447	HYD FILTER,INLINE 1/4FNPT 90M	*34	1	500000	1/2MNPT HEX PIPE NIPPLE STL
3	4	610528	PRESS COMP FIXED FLO REG 11G	*35	1	614719	HYD TUBE ASSY, AUX 204 GMC 96
* 4	1	607504	FLO DIV B50 2-8GPM 7/8 FOR	36	1	618440	9/16MJIC-90-9/16MOR EX LG LBO
5	1	610467	MODULAR MTR CONTROL ELECT VLV	37	1	618170	3/4MOR-9/16FOR ADPTR
* 6	1	614633	HYD MANIF 8200 86	*38	1	618310	9/16MJIC-7/8MOR ADPTR
* 7	1	605601	GRESEN FILTER 10 MICRON 40GPM	39	1	618119	9/16MJIC-90-9/16MOR LBO
* 8	1	607512	RELIEF VALVE, RL50, 1850 PSI	*40	2	618107	9/16MJIC-90-1/2MNPT LBO
9	4	470114	BREATHER FILTER VENT, 1/4 NPT	*41	1	618072	7/8MOR-1/2FNPT ADPTR
10	4	620900	CYL ASSY CC2016 D00 SRG 180	42	1	618600	9/16MJIC-90-7/8MOR LBO
11	8	610510	CESSNA GEAR MOTOR 1.48CT	43	4	614689	08C1T-08F3X-08F3X-120
*12	1	611126	7/8MJIC-7/8MOR ADPTR	44	2	614101	04C1T-06F3X-06F3X-133
13	4	618578	1 1/16F3JIC SWIV-1 1/16MOR	45	2	611246	04C1T-06F3X-06F3X-174
14	1	610193	9/16MJIC BLKHD BRANCH TEE	46	2	611262	04C1T-06F3X-06F3X-182
15	4	618019	9/16MJIC UNION TEE	*47	1	614348	16C2AT-16F3X-16F3X-.25
16	8	611121	9/16MJIC-1/4MNPT ADPTR	*48	1	601289	HOSE, 1 1/4 X 144 2BR RED
17	4	618248	1 1/16MJIC-90-1 1/16MOR LBO	49	4	616058	08C1T-08F3X-08F3X-80
*18	1	715660	HOSE BARB 1 1/4NPT X 1 1/4	50	4	614691	08C1T-08F3X-08F3X-220
19	2	618425	9/16MJIC-45-9/16MOR LBO	*51	1	616042	04C1T-06F3X-06F3X-13
*20	1	618587	1 5/16F3JIC SWIV-1MNPT	*52	1	615616	04C1T-06F3X-06F3X-65
21	12	618474	3/4MJIC-90-1 1/16MOR LBO	*53	1	614627	06C1T-06F3X-06F3X-45
*22	1	506410	BLK PIPE ST EL 90DEG 1.25NPT	54	2	614639	04C1T-06F3X-06F3X-126
*23	1	618144	1 1/4-1MP HEX PIPE NIPPLE STL	*55	1	614687	HYD TUBE ASSY SUND AUX 200 90
*24	4	611145	3/4MJIC-90-1/2MNPT LBO	*56	1	614664	10C1T-10F3X-10F3X-98
25	2	618590	3/4MJIC-45-3/4F3JIC SWIV LBO	57	1	616026	04C1T-06F3X-06F3X-37
*26	1	503700	PIPE PLUG .50NPT SQ HD	58	8	616027	04C1T-06F3X-06F3X-39
27	1	618126	9/16MJIC-9/16MOR ADPTR	59	1	618608	9/16F3JIC SWIV-1/4MNPT
28	5	611122	9/16MJIC-90-1/4MNPT LBO	*60	1	614703	HYD TUBE ASSY, 200 MAIN
29	1	618186	1 5/16MJIC-1 5/16MOR ADPTR	*61	1	614350	16C2AT-16F3X-16F3X-.55
30	8	618469	3/4MJIC-1 1/16MOR ADPTR	*62	2	618486	9/16F3JIC SW RUN TEE-9/16MJIC
*31	1	618577	1 5/16MJIC UNION	*63	2	618531	9/16F3JIC CAP NUT
32	1	618178	1 5/16MJIC-90-1 5/16MOR LBO				

200 4R QUAD 2L W/T-TROL HYD SCHEM 91
REFERENCE DRAWING NO. 498378

DET.	QTY	PART NO.	DESCRIPTION	DET.	QTY	PART NO.	DESCRIPTION
1	1	610532	ELECT HYD STACK VLV, 3 SECT	28	1	618600	9/16MJIC-90-7/8MOR LBO
2	1	610447	HYD FILTER, INLINE 1/4FNPT 90M	29	1	618186	1 5/16MJIC-1 5/16MOR ADPTR
3	4	610547	HYD MOTOR 4-.5CI 1IN SHFT	30	2	618469	3/4MJIC-1 1/16MOR ADPTR
* 4	1	607504	FLO DIV B50 2-8GPM 7/8 FOR	31	2	610186	1 1/16MOR PLUG
5	1	610467	MODULAR MTR CONTROL ELECT VLV	32	1	618178	1 5/16MJIC-90-1 5/16MOR LBO
* 6	1	614633	HYD MANIF 8200 86	33	2	501452	ST EL 90DEG .25NPT, STEEL,PLT
* 7	1	605601	GRESSEN FILTER 10 MICRON 40GPM	*34	1	500000	1/2NMPH HEX PIPE NIPPLE STL
* 8	1	607512	RELIEF VALVE, RLS0, 1850 PSI	*35	1	614350	16C2AT-16FCX-16FCX-55
9	2	470114	BREATHER FILTER VENT, 1/4 NPT	*36	1	618072	7/8MOR-1/2FNPT ADPTR
10	2	620900	CYL ASSY CC2016 D00 SRG 180	*37	2	618107	9/16MJIC-90-1/2MNP LBO
*11	1	611126	7/8MJIC-7/8MOR ADPTR	*38	1	601289	HOSE, 1 1/4 X 144 2BR RED
12	1	610185	9/16MOR PLUG	39	2	614101	04C1T-06FCX-06FCX-133
13	8	618327	3/4MJIC-7/8MOR ADPTR	*40	1	614348	16C2AT-16FCX-16FCX-25
*14	1	618577	1 5/16MJIC UNION	41	4	614689	08C1T-08FCX-08FCX-120
15	3	611122	9/16MJIC-90-1/4MNP LBO	*42	1	616042	04C1T-06FCX-06FCX-13
16	1	618440	9/16MJIC-90-9/16MOR EX LG LBO	*43	1	614627	06C1T-06FCX-06FCX-45
17	1	618170	3/4MOR-9/16FOR ADPTR	*44	1	615616	04C1T-06FCX-06FCX-65
*18	1	715660	HOSE BARB 1 1/4NPT X 1 1/4	*45	1	614687	HYD TUBE ASSY SUND AUX 200 90
19	1	618425	9/16MJIC-45-9/16MOR LBO	*46	1	614664	10C1T-10FCX-10FCX-98
*20	1	618587	1 5/16FCJIC SWIV-1MNP	47	2	616025	08C1T-08FCX-08FCX-50
21	1	618119	9/16MJIC-90-9/16MOR LBO	48	1	618590	3/4MJIC-45-3/4FCJIC SWIV LBO
*22	1	506410	BLK PIPE ST EL 90DEG 1.25NPT	*49	2	618532	3/4FCJIC CAP NUT
*23	1	618144	1 1/4-1MP HEX PIPE NIPPLE STL	50	1	618608	9/16FCJIC SWIV-1/4MNP
*24	1	618310	9/16MJIC-7/8MOR ADPTR	*51	1	614703	HYD TUBE ASSY, 200 MAIN
*25	4	611145	3/4MJIC-90-1/2MNP LBO	*52	2	618486	9/16FCJIC SW RUN TEE-9/16MJIC
*26	1	503700	PIPE PLUG .50NPT SQ HD	*53	1	614719	HYD TUBE ASSY, AUX 204 GMC 96
*27	5	618531	9/16FCJIC CAP NUT				

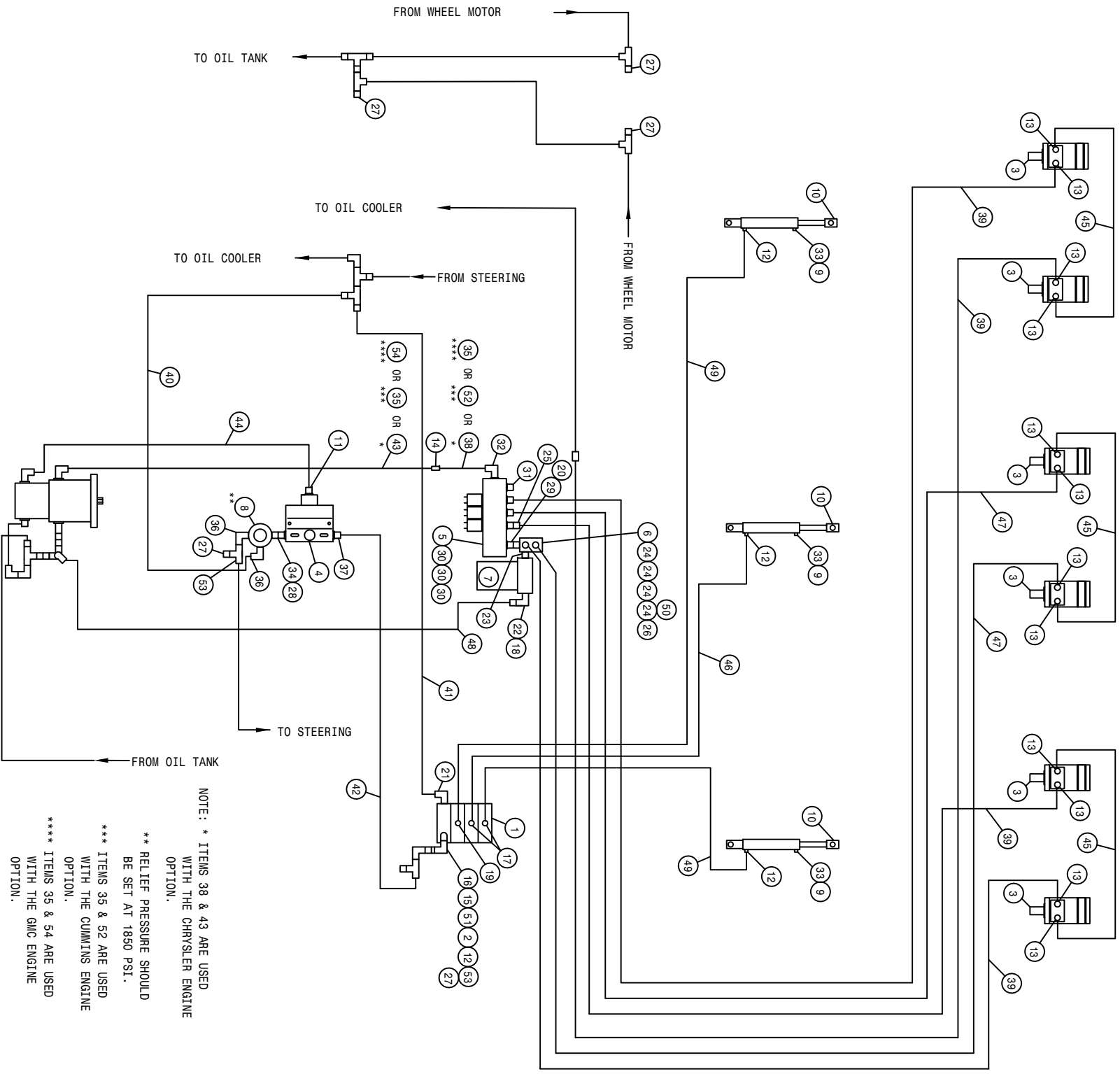

NOTE: * ITEMS 38 & 43 ARE USED WITH THE CHRYSLER ENGINE OPTION.
 ** RELIEF PRESSURE SHOULD BE SET AT 1850 PSI.
 *** ITEMS 35 & 52 ARE USED WITH THE CUMMINS ENGINE OPTION.
 **** ITEMS 35 & 54 ARE USED WITH THE GMC ENGINE OPTION.

200 6R QUAD 3L W/T-TROL HYD SCHEM 91
REFERENCE DRAWING NO. 498380

DET.	QTY	PART NO.	DESCRIPTION	DET.	QTY	PART NO.	DESCRIPTION
1	1	610532	ELECT HYD STACK VLV, 3 SECT	*28	1	618072	7/8MOR-1/2ENPT ADPTR
2	1	610447	HYD FILTER, INLINE 1/4FNPT 90M	29	1	618186	1 5/16MJIC-1 5/16MOR ADPTR
3	6	610547	HYD MOTOR 4.5CI 1IN SHFT	30	3	618469	3/4MJIC-1 1/16MOR ADPTR
*4	1	607504	FLO DIV B50 2-8GPM 7/8 FOR	31	1	610186	1 1/16MOR PLUG
5	1	610467	MODULAR MTR CONTROL ELECT VLV	32	1	618178	1 5/16MJIC-90-1 5/16MOR LBO
*6	1	614633	HYD MANIF 8200 86	33	3	501452	ST EL 90DEG .25NPT, STEEL,PLT
*7	1	605601	GRESEN FILTER 10 MICRON 40GPM	*34	1	500000	1/2MNPT HEX PIPE NIPPLE STL
*8	1	607512	RELIEF VALVE, RL50, 1850 PSI	*35	1	614350	16C2AT-16F3X-16F3X-55
9	3	470114	BREATHER FILTER VENT, 1/4 NPT	*36	2	618107	9/16MJIC-90-1/2MNPT LBO
10	3	620900	CYL ASSY CC2016 D00 SRG 180	*37	1	618310	9/16MJIC-7/8MOR ADPTR
*11	1	611126	7/8MJIC-7/8MOR ADPTR	*38	1	614348	16C2AT-16F3X-16F3X-25
12	4	611122	9/16MJIC-90-1/4MNPT LBO	39	4	614690	08C1T-08F3X-08F3X-192
13	12	618327	3/4MJIC-7/8MOR ADPTR	*40	1	616042	04C1T-06F3X-06F3X-13
*14	1	618577	1 5/16MJIC UNION	*41	1	614627	06C1T-06F3X-06F3X-45
15	1	618440	9/16MJIC-90-9/16MOR EX LG LBO	*42	1	615616	04C1T-06F3X-06F3X-65
16	1	618170	3/4MOR-9/16FOR ADPTR	*43	1	614687	HYD TUBE ASSY SUND AUX 200 90
17	2	618119	9/16MJIC-90-9/16MOR LBO	*44	1	614664	10C1T-10F3X-10F3X-98
*18	1	715660	HOSE BARB 1 1/4NPT X 1 1/4	45	3	616025	08C1T-08F3X-08F3X-50
19	1	618425	9/16MJIC-45-9/16MOR LBO	46	1	614077	04C1T-06F3X-06F3X-88
*20	1	618587	1 5/16FJIC SWIV-1MNPT	47	2	614688	08C1T-08F3X-08F3X-108
21	1	618600	9/16MJIC-90-7/8MOR LBO	*48	1	601289	HOSE, 1 1/4 X 144 2BR RED
*22	1	506410	BLK PIPE ST EL 90DEG 1.25NPT	49	2	614101	04C1T-06F3X-06F3X-133
*23	1	618144	1 1/4-1MP HEX PIPE NIPPLE STL	*50	1	618532	3/4FJIC CAP NUT
*24	4	611145	3/4MJIC-90-1/2MNPT LBO	51	1	618608	9/16FJIC SWIV-1/4MNPT
25	1	618590	3/4MJIC-45-3/4FJIC SWIV LBO	*52	1	614703	HYD TUBE ASSY, 200 MAIN
*26	1	503700	PIPE PLUG .50NPT SQ HD	*53	2	618486	9/16FJIC SW RUN TEE-9/16MJIC
*27	5	618531	9/16FJIC CAP NUT	*54	1	614719	HYD TUBE ASSY, AUX 204 GMC 96

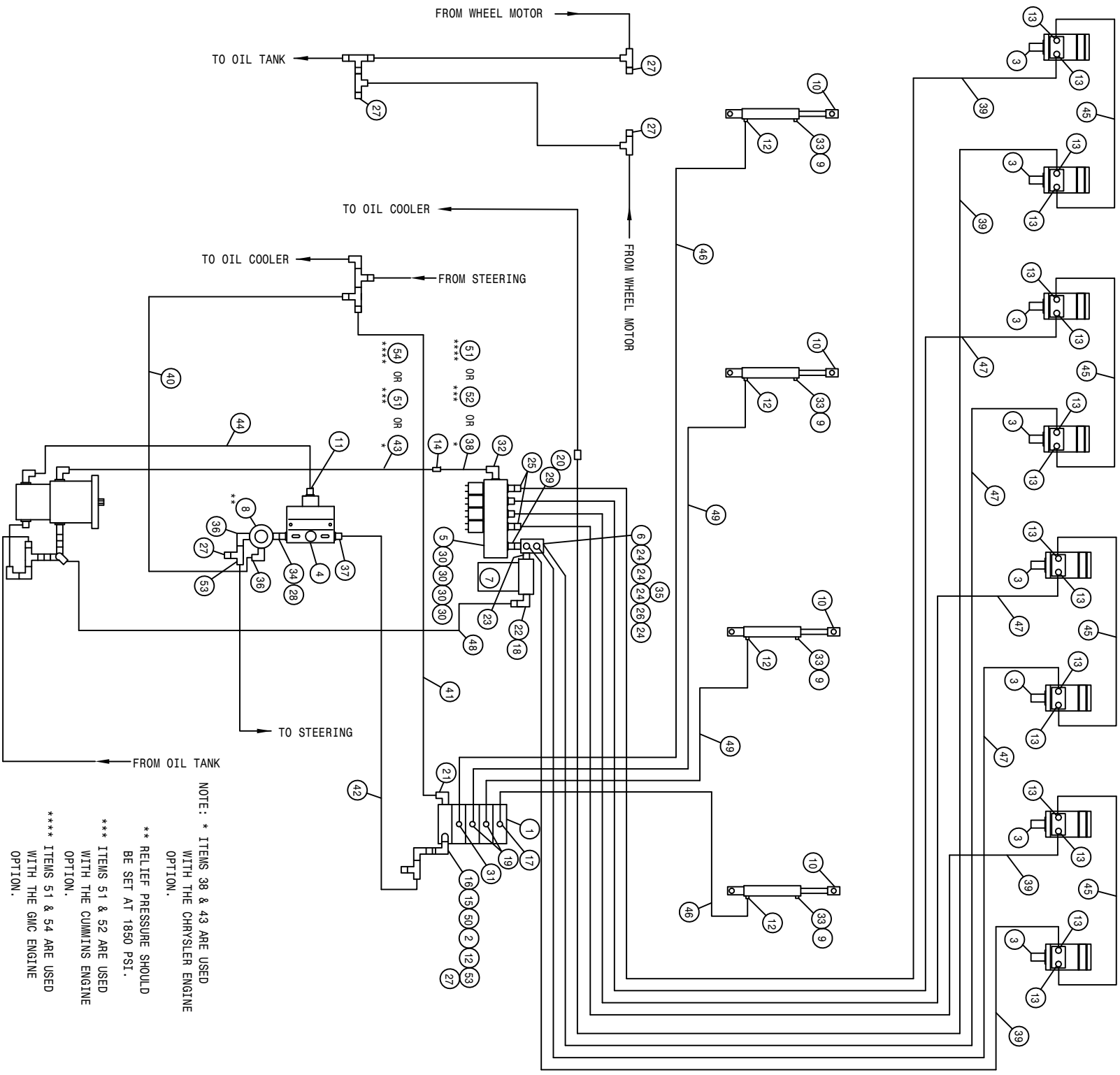

NOTE: * ITEMS 38 & 43 ARE USED WITH THE CHRYSLER ENGINE OPTION.
 ** RELIEF PRESSURE SHOULD BE SET AT 1850 PSI.
 *** ITEMS 51 & 52 ARE USED WITH THE CUMMINS ENGINE OPTION.
 **** ITEMS 51 & 54 ARE USED WITH THE GMC ENGINE OPTION.

200 8R QUAD 4L W/T-TROL HYD SCHEM 91
REFERENCE DRAWING NO. 498382

DET.	QTY	PART NO.	DESCRIPTION	DET.	QTY	PART NO.	DESCRIPTION
1	1	610613	ELECT HYD STACT VLV, 4 SECT	*28	1	618072	7/8MOR-1/2ENPT ADPTR
2	1	610447	HYD FILTER, INLINE 1/4FNPT 90M	29	1	618186	1 5/16MJIC-1 5/16MOR ADPTR
3	8	610547	HYD MOTOR 4.5CI 1IN SHFT	30	4	618469	3/4MJIC-1 1/16MOR ADPTR
*4	1	607504	FLO DIV B50 2-8GPM 7/8 FOR	31	1	618126	9/16MJIC-9/16MOR ADPTR
5	1	610467	MODULAR MTR CONTROL ELECT VLV	32	1	618178	1 5/16MJIC-90-1 5/16MOR LBO
*6	1	614633	HYD MANIF 8200 86	33	1	618152	ST EL 90DEG .25NPT, STEEL,PLT
*7	1	605601	GRESN FILTER 10 MICRON 40GPM	*34	4	501452	1/2MNPT HEX PIPE NIPPLE STL
*8	1	607512	RELIEF VALVE, RL50, 1850 PSI	*35	1	618532	3/4FJIC CAP NUT
9	4	470114	BREATHER FILTER VENT, 1/4 NPT	*36	2	618107	9/16MJIC-90-1/2MNPT LBO
10	4	620900	CYL ASSY CC2016 D00 SRG 180	*37	1	618310	9/16MJIC-7/8MOR ADPTR
*11	1	611126	7/8MJIC-7/8MOR ADPTR	*38	1	614348	16C2AT-16FJX-16FJX-25
12	5	611122	9/16MJIC-90-1/4MNPT LBO	39	4	614691	08C1T-.08FJX-.08FJX-220
13	16	618327	3/4MJIC-7/8MOR ADPTR	*40	1	616042	04C1T-.06FJX-.06FJX-13
*14	1	618577	1 5/16MJIC UNION	*41	1	614627	06C1T-.06FJX-.06FJX-45
15	1	618440	9/16MJIC-90-9/16MOR EX LG LBO	*42	1	615616	04C1T-.06FJX-.06FJX-65
16	1	618170	3/4MOR-9/16FOR ADPTR	43	1	614687	HYD TUBE ASSY SUND AUX 200 90
17	1	618119	9/16MJIC-90-9/16MOR LBO	*44	1	614664	10C1T-.10FJX-.10FJX-98
*18	1	715660	HOSE BARB 1 1/4NPT X 1 1/4	45	4	616025	08C1T-.08FJX-.08FJX-50
19	2	618425	9/16MJIC-45-9/16MOR LBO	46	2	611246	04C1T-.06FJX-.06FJX-174
*20	1	618587	1 5/16FJIC SWIV-1MNPT	47	4	614689	08C1T-.08FJX-.08FJX-120
21	1	618600	9/16MJIC-90-7/8MOR LBO	*48	1	601289	HOSE, 1 1/4 X 144 2BR RED
*22	1	506410	BLK PIPE ST EL 90DEG 1.25NPT	49	2	614101	04C1T-.06FJX-.06FJX-133
*23	1	618144	1 1/4-1MP HEX PIPE NIPPLE STL	50	1	618608	9/16FJIC SWIV-1/4MNPT
*24	4	611145	3/4MJIC-90-1/2MNPT LBO	*51	1	614350	16C2AT-16FJX-16FJX-55
25	2	618590	3/4MJIC-45-3/4FJIC SWIV LBO	*52	1	614703	HYD TUBE ASSY, 200 MAIN
*26	1	503700	PIPE PLUG .50NPT SQ HD	*53	2	618486	9/16FJIC SW RUN TEE-9/16MJIC
*27	5	618531	9/16FJIC CAP NUT	*54	1	614719	HYD TUBE ASSY, AUX 204 GMC 96

200 10R QUAD 4L W/T-TROL HYD SCHEM 94
REFERENCE DRAWING NO. 498440

DET.	QTY	PART NO.	DESCRIPTION	DET.	QTY	PART NO.	DESCRIPTION
1	1	610613	ELECT HYD STACT VLV, 4 SECT	30	4	618469	3/4MJIC-1 1/16MOR ADPTR
2	1	610447	HYD FILTER, INLINE 1/4FNPT 90M	31	1	618126	9/16MJIC-9/16MOR ADPTR
3	10	610547	HYD MOTOR 4.5CI 1IN SHFT	32	1	618178	1 5/16MJIC-90-1 5/16MOR LBO
*4	1	607504	FLO DIV B50 2-8GPM 7/8 FOR	33	4	501452	ST EL 90DEG .25NPT, STEEL, PLT
5	1	610467	MODULAR MTR CONTROL ELECT VLV	*34	1	500000	1/2MNPT HEX PIPE NIPPLE STL
*6	1	614633	HYD MANIF 8200 86	35	2	614384	08C1T-08FCX-08FCX-237
*7	1	605601	GRESEN FILTER 10 MICRON 40GPM	*36	2	618107	9/16MJIC-90-1/2MNPT LBO
*8	1	607512	RELIEF VALVE, RL50, 1850 PSI	*37	1	618310	9/16MJIC-7/8MOR ADPTR
9	4	470114	BREATHER FILTER VENT, 1/4 NPT	*38	1	614348	16C2AT-16FCX-16FCX-25
10	4	620900	CYL ASSY CC2016 D00 SRG 180	*39	2	614387	08C1T-08FCX-08FCX-267
*11	1	611126	7/8MJIC-7/8MOR ADPTR	*40	1	616042	04C1T-06FCX-06FCX-13
12	5	611122	9/16MJIC-90-1/4MNPT LBO	*41	1	614627	06C1T-06FCX-06FCX-45
13	20	618327	3/4MJIC-7/8MOR ADPTR	*42	1	615616	04C1T-06FCX-06FCX-65
*14	1	618577	1 5/16MJIC UNION	*43	1	614687	HYD TUBE ASSY SUND AUX 200 90
15	1	618440	9/16MJIC-90-9/16MOR EX LG LBO	*44	1	614664	10C1T-10FCX-10FCX-98
16	1	618170	3/4MOR-9/16FOR ADPTR	45	6	616025	08C1T-08FCX-08FCX-50
17	1	618119	9/16MJIC-90-9/16MOR LBO	46	2	614098	04C1T-06FCX-06FCX-201
*18	1	715660	HOSE BARB 1 1/4NPT X 1 1/4	47	4	614689	08C1T-08FCX-08FCX-120
19	2	618425	9/16MJIC-45-9/16MOR LBO	*48	1	601289	HOSE, 1 1/4 X 144 2BR RED
*20	1	618587	1 5/16FCJIC SWIV-1MNPT	49	2	611202	04C1T-06FCX-06FCX-136
21	1	618600	9/16MJIC-90-7/8MOR LBO	50	1	618608	9/16FCJIC SWIV-1/4MNPT
*22	1	506410	BLK PIPE ST EL 90DEG 1.25NPT	*51	1	614350	16C2AT-16FCX-16FCX-55
*23	1	618144	1 1/4-1MP HEX PIPE NIPPLE STL	*52	1	614703	HYD TUBE ASSY, 200 MAIN
*24	4	611145	3/4MJIC-90-1/2MNPT LBO	*53	1	618532	3/4FCJIC CAP NUT
25	2	618590	3/4MJIC-45-3/4FCJIC SWIV LBO	54	2	618586	7/8MOR UNION
*26	1	503700	PIPE PLUG .50NPT SQ HD	55	2	607522	FLOW REGULATOR, 8GPM VONBERG
*27	5	618531	9/16FCJIC CAP NUT	*56	2	618486	9/16FCJIC SW RUN TEE-9/16MJIC
*28	1	618072	7/8MOR-1/2FNPT ADPTR	*57	1	614719	HYD TUBE ASSY, AUX 204 GMC 96
29	1	618186	1 5/16MJIC-1 5/16MOR ADPTR				

200 12R QUAD 4L W/T-TROL HYD SCHEM 92
REFERENCE DRAWING NO. 498423

DET.	QTY	PART NO.	DESCRIPTION	DET.	QTY	PART NO.	DESCRIPTION
1	1	610613	ELECT HYD STACT VLV, 4 SECT	29	1	618186	1 5/16MJIC-1 5/16MOR ADPTR
2	1	610447	HYD FILTER, INLINE 1/4FNPT 90M	30	4	618469	3/4MJIC-1 1/16MOR ADPTR
3	12	610547	HYD MOTOR 4.5CI 1IN SHFT	31	1	618126	9/16MJIC-9/16MOR ADPTR
*4	1	607504	FLO DIV B50 2-8GPM 7/8 FOR	32	1	618178	1 5/16MJIC-90-1 5/16MOR LBO
5	1	610467	MODULAR MFR CONTROL ELECT VLV	33	4	501452	ST EL 90DEG .25NPT, STEEL,PLT
*6	1	614633	HYD MANIF 8200 86	*34	1	500000	1/2MNPT HEX PIPE NIPPLE STL
*7	1	605601	GRESEN FILTER 10 MICRON 40GPM	35	2	614384	08C1T-08FJX-08FJX-237
*8	1	607512	RELIEF VALVE, RL50, 1850 PSI	*36	2	618107	9/16MJIC-90-1/1/2MNPT LBO
9	4	470114	BREATHER FILTER VENT, 1/4 NPT	*37	1	618310	9/16MJIC-7/8MOR ADPTR
10	4	620900	CYL ASSY CC2016 D00 SRG 180	*38	1	614348	16G2AT-16FJX-16FJX-25
*11	1	611126	7/8MJIC-7/8MOR ADPTR	39	2	614375	08C1T-08FJX-08FJX-177
12	5	611122	9/16MJIC-90-1/4MNPT LBO	*40	1	616042	04C1T-06FJX-06FJX-13
13	24	618327	3/4MJIC-7/8MOR ADPTR	*41	1	614627	06C1T-06FJX-06FJX-45
*14	1	618577	1 5/16MJIC UNION	*42	1	615616	04C1T-06FJX-06FJX-65
15	1	618440	9/16MJIC-90-9/16MOR EX LG LBO	*43	1	614687	HYD TUBE ASSY SUND AUX 200 90
16	1	618170	3/4MOR-9/16FOR ADPTR	*44	1	614664	10C1T-10FJX-10FJX-98
17	1	618119	9/16MJIC-90-9/16MOR LBO	45	8	616025	08C1T-08FJX-08FJX-50
*18	1	715660	HOSE BARB 1 1/4NPT X 1 1/4	46	2	614098	04C1T-06FJX-06FJX-201
19	2	618425	9/16MJIC-45-9/16MOR LBO	47	2	614378	08C1T-08FJX-08FJX-207
*20	1	618587	1 5/16FJIC SWIV-1MNPT	*48	1	601289	HOSE, 1 1/4 X 144 2BR RED
21	1	618600	9/16MJIC-90-7/8MOR LBO	49	2	611202	04C1T-06FJX-06FJX-136
*22	1	506410	BLK PIPE ST EL 90DEG 1.25NPT	50	1	618608	9/16FJIC SWIV-1/4MNPT
*23	1	618144	1 1/4-1MP HEX PIPE NIPPLE STL	*51	1	614350	16G2AT-16FJX-16FJX-55
*24	4	611145	3/4MJIC-90-1/2MNPT LBO	*52	1	614703	HYD TUBE ASSY, 200 MAIN
25	2	618590	3/4MJIC-45-3/4FJIC SWIV LBO	*53	1	618532	3/4FJIC CAP NUT
*26	1	503700	PIPE PLUG .50NPT SQ HD	54	2	614387	08C1T-08FJX-08FJX-267
*27	5	618531	9/16FJIC CAP NUT	*55	2	618486	9/16FJIC SW RUN TEE-9/16MJIC
*28	1	618072	7/8MOR-1/2FNPT ADPTR	*56	1	614719	HYD TUBE ASSY, AUX 204 GMC 96

200 4R PULLER 2L W/T-TROL HYD SCHEM 91
REFERENCE DRAWING NO. 498384

DET.	QTY	PART NO.	DESCRIPTION	DET.	QTY	PART NO.	DESCRIPTION
1	1	610532	ELECT HYD STACK VLV, 3 SECT	28	1	618600	9/16MJIC-90-7/8MOR LBO
2	1	610447	HYD FILTER, INLINE 1/4FNPT 90M	29	1	618186	1 5/16MJIC-1 5/16MOR ADPTR
3	4	604005	ORBIT MOTOR A5E	30	2	618469	3/4MJIC-1 1/16MOR ADPTR
*4	1	607504	FLO DIV B50 2-8GPM 7/8 FOR	31	2	610186	1 1/16MOR PLUG
5	1	610463	MODULAR MTR CONTROL ELECT VLV	32	1	618178	1 5/16MJIC-90-1 5/16MOR LBO
*6	1	614633	HYD MANIF 8200 86	33	2	501452	ST EL 90DEG .25NPT, STEEL, PLT
*7	1	605601	GRESN FILTER 10 MICRON 40GPM	*34	1	500000	1/2MNPT HEX PIPE NIPPLE STL
*8	1	607512	RELIEF VALVE, RL50, 1850 PSI	*35	1	614350	16C2AT-16F3X-16F3X-55 H/A
9	2	470114	BREATHER FILTER VENT, 1/4 NPT	*36	1	618072	7/8MOR-1/2FNPT ADPTR
10	2	620900	CYL ASSY CC2016 D00 SRG 180	*37	2	618107	9/16MJIC-90-1/2MNPT LBO
*11	1	611126	7/8MJIC-7/8MOR ADPTR	*38	1	618310	9/16MJIC-7/8MOR ADPTR
12	1	610185	9/16MOR PLUG	39	2	614101	04C1T-06F3X-06F3X-133 H/A
13	4	611147	3/4MJIC-1/2MNPT ADPTR	*40	1	614348	16C2AT-16F3X-16F3X-25 H/A
*14	1	618577	1 5/16MJIC UNION	41	4	614689	08C1T-08F3X-08F3X-120 H/A
15	3	611122	9/16MJIC-90-1/4MNPT LBO	*42	1	616042	04C1T-06F3X-06F3X-13 H/A
16	1	618440	9/16MJIC-90-9/16MOR EX LG LBO	*43	1	614627	06C1T-06F3X-06F3X-45 H/A
17	1	618170	3/4MOR-9/16FOR ADPTR	*44	1	615616	04C1T-06F3X-06F3X-65 H/A
*18	1	715660	HOSE BARB 1 1/4NPT X 1 1/4	*45	1	614687	HYD TUBE ASSY SUND AUX 200 90
19	1	618425	9/16MJIC-45-9/16MOR LBO	*46	1	614664	10C1T-10F3X-10F3X-98 H/A
*20	1	618587	1 5/16F3JIC SWIV-1MNPT	47	2	614382	08C1T-08F3X-08F3X-40 H/A
21	1	618119	9/16MJIC-90-9/16MOR LBO	*48	1	601289	HOSE, 1 1/4 X 144 2BR RED
*22	1	506410	BLK PIPE ST EL 90DEG 1.25NPT	49	1	618590	3/4MJIC-45-3/4FJIC SWIV LBO
*23	1	618144	1 1/4-1MP HEX PIPE NIPPLE STL	50	1	618608	9/16FJIC SWIV-1/4MNPT
*24	8	611145	3/4MJIC-90-1/2MNPT LBO	*51	1	614703	HYD TUBE ASSY, 200 MAIN 92
*25	2	618532	3/4FJIC CAP NUT	*52	2	618486	9/16FJIC SW RUN TEE-9/16MJIC
*26	1	503700	PIPE PLUG .50NPT SQ HD	*53	1	614719	HYD TUBE ASSY, AUX 204 GMC 96
*27	5	618531	9/16FJIC CAP NUT				

200 6R PULLER 3L W/T-TROL HYD SCHEM 91
REFERENCE DRAWING NO. 498386

DET.	QTY	PART NO.	DESCRIPTION	DET.	QTY	PART NO.	DESCRIPTION
1	1	610532	ELECT HYD STACK VLV, 3 SECT	*28	1	618072	7/8MOR-1/2ENPT ADPTR
2	1	610447	HYD FILTER, INLINE 1/4FNPT 90M	29	1	618186	1 5/16MJIC-1 5/16MOR ADPTR
3	6	604005	ORBIT MOTOR A5E	30	3	618469	3/4MJIC-1 1/16MOR ADPTR
*4	1	607504	FLO DIV B50 2-8GPM 7/8 FOR	31	1	610186	1 1/16MOR PLUG
5	1	610467	MODULAR MTR CONTROL ELECT VLV	32	1	618178	1 5/16MJIC-90-1 5/16MOR LBO
*6	1	614653	HYD MANIF 8200 86	33	3	501452	ST EL 90DEG .25NPT, STEEL,PLT
*7	1	605601	GRESEN FILTER 10 MICRON 40GPM	*34	1	500000	1/2MNPT HEX PIPE NIPPLE STL
*8	1	607512	RELIEF VALVE, RL50, 1850 PSI	*35	1	614350	16C2AT-16FJX-16FJX-55
9	3	470114	BREATHER FILTER VENT, 1/4 NPT	*36	2	618107	9/16MJIC-90-1/2MNPT LBO
10	3	620900	CYL ASSY CC2016 D00 SRG 180	*37	1	618310	9/16MJIC-7/8MOR ADPTR
*11	1	611126	7/8MJIC-7/8MOR ADPTR	*38	1	614348	16C2AT-16FJX-16FJX-25
12	4	611122	9/16MJIC-90-1/4MNPT LBO	39	4	614690	08C1T-08FJX-08FJX-192
13	6	611147	3/4MJIC-1/2MNPT ADPTR	*40	1	616042	04C1T-06FJX-06FJX-13
*14	1	618577	1 5/16MJIC UNION	*41	1	614627	06C1T-06FJX-06FJX-45
15	1	618440	9/16MJIC-90-9/16MOR EX LG LBO	*42	1	615616	04C1T-06FJX-06FJX-65
16	1	618170	3/4MOR-9/16FOR ADPTR	*43	1	614687	HYD TUBE ASSY SUND AUX 200 90
17	2	618119	9/16MJIC-90-9/16MOR LBO	*44	1	614664	10C1T-10FJX-10FJX-98
*18	1	715660	HOSE BARB 1 1/4NPT X 1 1/4	45	3	614382	08C1T-08FJX-08FJX-40
19	1	618425	9/16MJIC-45-9/16MOR LBO	46	1	614077	04C1T-06FJX-06FJX-88
*20	1	618587	1 5/16FJIC SWIV-1MNPT	47	2	614688	08C1T-08FJX-08FJX-108
21	1	618600	9/16MJIC-90-7/8MOR LBO	*48	1	601289	HOSE, 1 1/4 X 144 2BR RED
*22	1	506410	BLK PIPE ST EL 90DEG 1.25NPT	49	2	614101	04C1T-06FJX-06FJX-133
*23	1	618144	1 1/4-1MP HEX PIPE NIPPLE STL	*50	10	611145	3/4MJIC-90-1/2MNPT LBO
*24	1	618532	3/4FJIC CAP NUT	51	1	618608	9/16FJIC SWIV-1/4MNPT
25	1	618590	3/4MJIC-45-3/4FJIC SWIV LBO	*52	1	614703	HYD TUBE ASSY, 200 MAIN
*26	1	503700	PIPE PLUG .50NPT SQ HD	*53	2	618486	9/16FJIC SW RUN TEE-9/16MJIC
*27	5	618531	9/16FJIC CAP NUT	*54	1	614719	HYD TUBE ASSY, AUX 204 GMC 96

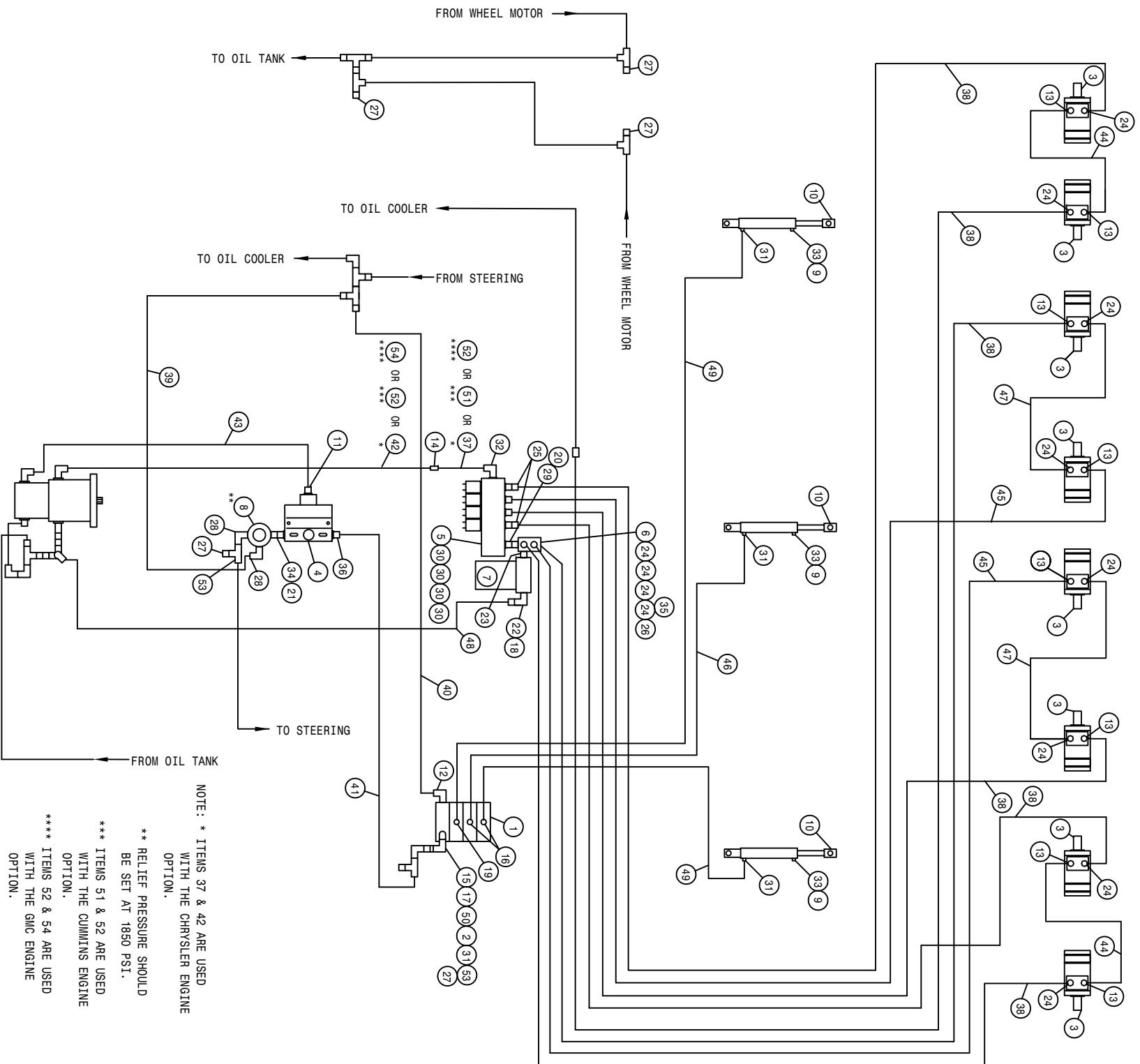

NOTE: * ITEMS 37 & 42 ARE USED WITH THE CHRYSLER ENGINE OPTION.

** RELIEF PRESSURE SHOULD BE SET AT 1850 PSI.

*** ITEMS 51 & 52 ARE USED WITH THE CUMMINS ENGINE OPTION.

**** ITEMS 52 & 54 ARE USED WITH THE GMC ENGINE OPTION.

200 8R PULLER 3L W/T-TROL HYD SCHEM 91
REFERENCE DRAWING NO. 498388

DET.	QTY	PART NO.	DESCRIPTION	DET.	QTY	PART NO.	DESCRIPTION
1	1	610532	ELECT HYD STACK VLV, 3 SECT	*28	2	618107	9/16MJIC-90-1/2MNPT LBO
2	1	610447	HYD FILTER, INLINE 1/4FNPT 90M	29	1	618186	1 5/16MJIC-1 5/16MOR ADPTR
3	8	604005	ORBIT MOTOR A5E	30	4	618469	3/4MJIC-1 1/16MOR ADPTR
*4	1	607504	FLO DIV B50 2-8GPM 7/8 FOR	31	4	611122	9/16MJIC-90-1/4MNPT LBO
5	1	610467	MODULAR MTR CONTROL ELECT VLV	32	1	618178	1 5/16MJIC-90-1 5/16MOR LBO
*6	1	614633	HYD MANIF 8200 86	33	3	501452	ST EL 90DEG .25NPT, STEEL, PLT
*7	1	605601	GRESEN FILTER 10 MICRON 40GPM	*34	1	500000	1/2MNPT HEX PIPE NIPPLE STL
*8	1	607512	RELIEF VALVE, RL50, 1850 PSI	*35	1	618532	3/4FJIC CAP NUT
9	3	470114	BREATHER FILTER VENT, 1/4 NPT	*36	1	618310	9/16MJIC-7/8MOR ADPTR
10	3	620900	CYL ASSY CC2016 D00 SRG 180	*37	1	614348	16C2AT-16FJX-16FJX-25
*11	1	611126	7/8MJIC-7/8MOR ADPTR	38	6	614691	08C1T-08FJX-08FJX-220
12	1	618600	9/16MJIC-90-7/8MOR LBO	*39	1	616042	04C1T-06FJX-06FJX-13
13	8	611147	3/4MJIC-1/2MNPT ADPTR	*40	1	614627	06C1T-06FJX-06FJX-45
*14	1	618577	1 5/16MJIC UNION	*41	1	615616	04C1T-06FJX-06FJX-65
15	1	618170	3/4MOR-9/16FOR ADPTR	*42	1	614687	HYD TUBE ASSY SUND AUX 200 90
16	2	618119	9/16MJIC-90-9/16MOR LBO	*43	1	614664	10C1T-10FJX-10FJX-98
17	1	618440	9/16MJIC-90-9/16MOR EX LG LBO	44	2	614382	08C1T-08FJX-08FJX-40
*18	1	715660	HOSE BARB 1 1/4NPT X 1 1/4	45	2	614688	08C1T-08FJX-08FJX-108
19	1	618425	9/16MJIC-45-9/16MOR LBO	46	1	614077	04C1T-06FJX-06FJX-88
*20	1	618587	1 5/16FJIC SWIV-1MNPT	47	2	614384	08C1T-08FJX-08FJX-237
*21	1	618072	7/8MOR-1/2FNPT ADPTR	*48	1	601289	HOSE, 1 1/4 X 144 2BR RED
*22	1	506410	BLK PIPE ST EL 90DEG 1.25NPT	49	2	611246	04C1T-06FJX-06FJX-174
*23	1	618144	1 1/4-1MP HEX PIPE NIPPLE STL	50	1	618608	9/16FJIC SWIV-1/4MNPT
*24	12	611145	3/4MJIC-90-1/2MNPT LBO	*51	1	614703	HYD TUBE ASSY, 200 MAIN
25	2	618590	3/4MJIC-45-3/4FJIC SWIV LBO	*52	1	614350	16C2AT-16FJX-16FJX-55
*26	1	503700	PIPE PLUG .50NPT SQ HD	*53	2	618486	9/16FJIC SW RUN TEE-9/16MJIC
*27	5	618531	9/16FJIC CAP NUT	*54	1	614719	HYD TUBE ASSY, AUX 204 GMC 96

200 4R CUTTER 2L W/T-TROL HYD SCHEM 91
REFERENCE DRAWING NO. 498390

DET.	QTY	PART NO.	DESCRIPTION	DET.	QTY	PART NO.	DESCRIPTION
1	1	610532	ELECT HYD STACK VLV, 3 SECT	30	2	618469	3/4MJC-1 1/16MOR ADPTR
2	1	610447	HYD FILTER, INLINE 1/4FNPT 90M	31	2	610186	1 1/16MOR PLUG
3	4	610590	BARNES HYD MOTOR	32	1	618178	1 5/16MJC-90-1 5/16MOR LBO
4	1	607504	FLO DIV B50 2-8GPM 7/8 FOR	33	2	501452	ST EL 90DEG .25NPT, STEEL, PLT
5	1	610467	MODULAR MTR CONTROL ELECT VLV	*34	1	500000	1/2MNP HEX PIPE NIPPLE STL
6	1	614635	HYD MANIF 8200 86	*35	1	614350	16C2AT-16FCX-16FCX-55 H/A
7	1	605601	GRESEN FILTER 10 MICRON 40GPM	36	1	618119	9/16MJC-90-9/16MOR LBO
8	1	607512	RELIEF VALVE, RL50, 1850 PSI	37	1	618600	9/16MJC-90-7/8MOR LBO
9	2	470114	BREATHER FILTER VENT, 1/4 NPT	*38	1	618310	9/16MJC-7/8MOR ADPTR
10	2	620900	CYL ASSY CC2016 D00 SRG 180	*39	1	618072	7/8MOR-1/2FNPT ADPTR
*11	1	611126	7/8MJC-7/8MOR ADPTR	*40	1	616042	04CIT-06FCX-06FCX-13 H/A
12	2	618530	9/16MJC-1/8MNP ADPTR	*41	1	614627	06CIT-06FCX-06FCX-45 H/A
13	8	611125	3/4MJC-3/4MOR ADPTR	*42	1	615616	04CIT-06FCX-06FCX-65 H/A
*14	1	618577	1 5/16MJC UNION	*43	1	614687	HYD TUBE ASSY SUND AUX 200 90 H/A
15	2	618546	1/8MNP RUN TEE-9/16MJC	*44	1	614664	10CIT-10FCX-10FCX-98 H/A
*16	2	618107	9/16MJC-90-1/2MNP LBO	45	2	614368	08CIT-08FCX-08FCX-60 H/A
17	3	611122	9/16MJC-90-1/4MNP LBO	46	2	614639	04CIT-06FCX-06FCX-126 H/A
*18	1	715660	HOSE BARB 1 1/4NPT X 1 1/4	47	4	614689	08CIT-08FCX-08FCX-120 H/A
19	1	618425	9/16MJC-45-9/16MOR LBO	*48	1	601289	HOSE, 1 1/4 X 144 2BR RED
*20	1	618587	1 5/16FCJIC SWIV-1MNP	49	2	614101	04CIT-06FCX-06FCX-133 H/A
21	1	618440	9/16MJC-90-9/16MOR EX LG LBO	*50	1	614348	16C2AT-16FCX-16FCX-25 H/A
*22	1	506410	BLK PIPE ST EL 90DEG 1.25NPT	51	2	611206	04CIT-06FCX-06FCX-66 H/A
*23	1	618144	1 1/4-1MP HEX PIPE NIPPLE STL	52	1	618590	3/4MJC-45-3/4FCJIC SWIV LBO
24	1	610185	9/16MOR PLUG	*53	2	618532	3/4FCJIC CAP NUT
*25	4	611145	3/4MJC-90-1/2MNP LBO	54	1	618608	9/16FCJIC SWIV-1/4MNP
*26	1	503700	PIPE PLUG .50NPT SQ HD	*55	1	614703	HYD TUBE ASSY, 200 MAIN 92
*27	3	618531	9/16FCJIC CAP NUT	*56	2	618486	9/16FCJIC SW RUN TEE-9/16MJC
28	1	618170	3/4MOR-9/16FOR ADPTR	*57	1	614719	HYD TUBE ASSY, AUX 204 GMC 96
29	1	618186	1 5/16MJC-1 5/16MOR ADPTR				

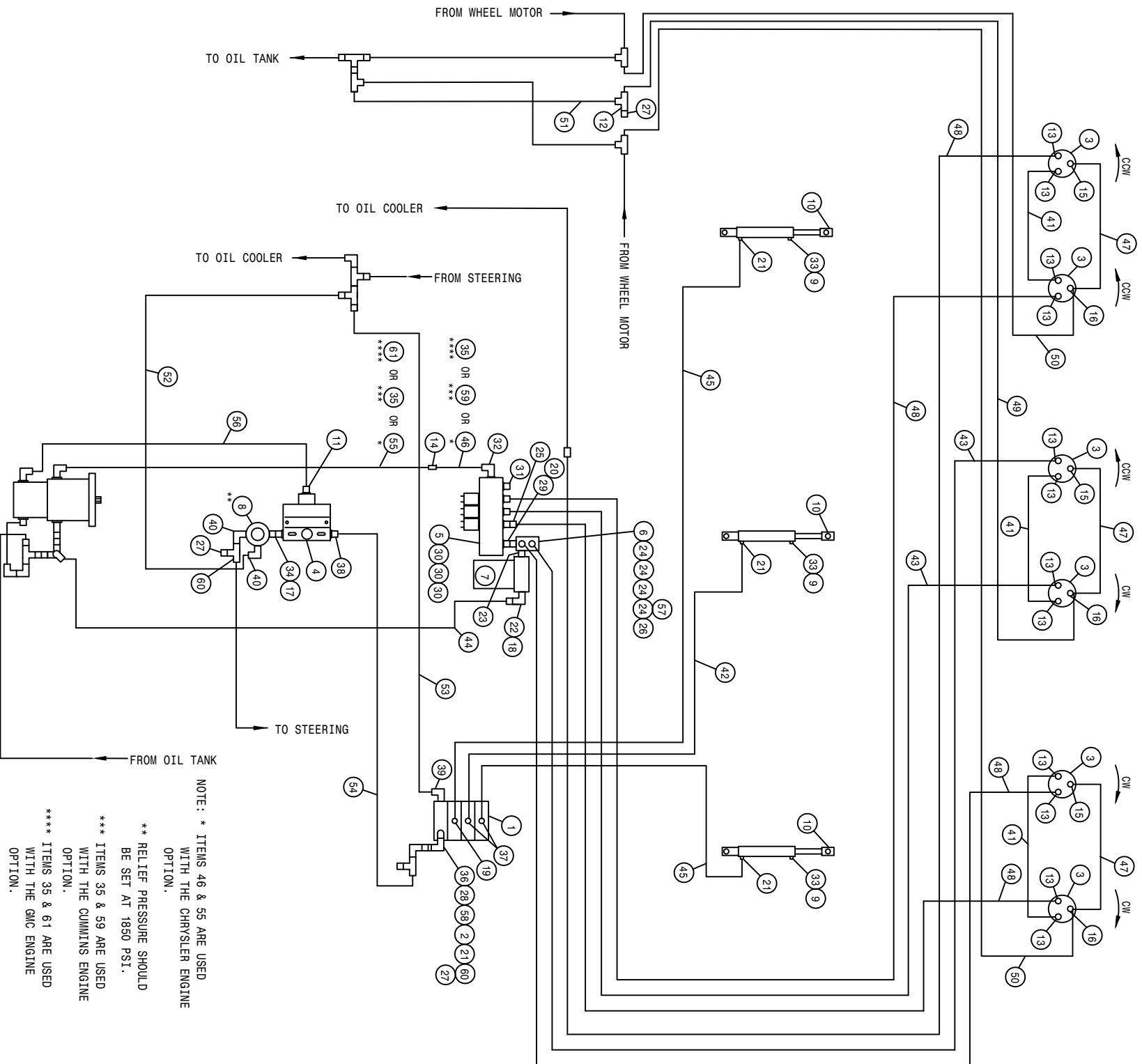

NOTE: * ITEMS 46 & 55 ARE USED WITH THE CHRYSLER ENGINE OPTION.
 ** RELIEF PRESSURE SHOULD BE SET AT 1850 PSI.
 *** ITEMS 35 & 59 ARE USED WITH THE CUMMINS ENGINE OPTION.
 **** ITEMS 35 & 61 ARE USED WITH THE GMC ENGINE OPTION.

200 6R CUTTER 3L W/T-TROL HYD SCHEM 91
REFERENCE DRAWING NO. 498392

DET.	QTY	PART NO.	DESCRIPTION	DET.	QTY	PART NO.	DESCRIPTION
1	1	610532	ELECT HYD STACK VLV, 3 SECT	32	1	618178	1 5/16MJIC-90-1 5/16MOR LBO
2	1	610447	HYD FILTER, INLINE 1/4ENPT 90M	33	3	501452	ST EL 90DEG .25NPT, STEEL, PLT
3	6	610590	BARNES HYD MOTOR	*34	1	500000	1/2MNPT HEX PIPE NIPPLE STL
*4	1	607504	FLO DIV B50 2-8GPM 7/8 FOR	*35	1	614350	16C2AT-16FJX-16FJX-55 H/A
5	1	610467	MODULAR MTR CONTROL ELECT VLV	36	1	618170	3/4MOR-9/16FOR ADPTR
*6	1	614635	HYD MANIF 8200 86	37	2	618119	9/16MJIC-90-9/16MOR LBO
*7	1	605601	GRESEN FILTER 10 MICRON 40GPM	*38	1	618310	9/16MJIC-7/8MOR ADPTR
*8	1	607512	RELIEF VALVE, RL50, 1850 PSI	39	1	618600	9/16MJIC-90-7/8MOR LBO
9	3	470114	BREATHER FILTER VENT, 1/4 NPT	*40	2	618107	9/16MJIC-90-1/2MNPT LBO
10	3	620900	CYL ASSY CC2016 D00 SRG 180	41	3	614368	08CIT-08FJX-08FJX-60 H/A
*11	1	611126	7/8MJIC-7/8MOR ADPTR	42	1	614077	04CIT-06FJX-06FJX-88 H/A
12	1	610193	9/16MJIC BLKHD BRANCH TEE	43	2	614688	08CIT-08FJX-08FJX-108 H/A
13	12	611125	3/4MJIC-3/4MOR ADPTR	*44	1	601289	HOSE, 1 1/4 X 144 2BR RED
*14	1	618577	1 5/16MJIC UNION	45	2	614101	04CIT-06FJX-06FJX-133 H/A
15	3	618530	9/16MJIC-1/8MNPT ADPTR	*46	1	614348	16C2AT-16FJX-16FJX-25 H/A
16	3	618546	1/8MNPT RUN TEE-9/16MJIC	47	3	611206	04CIT-06FJX-06FJX-66 H/A
*17	1	618072	7/8MOR-1/2ENPT ADPTR	48	4	614690	08CIT-08FJX-08FJX-192 H/A
*18	1	715660	HOSE BARB 1 1/4NPT X 1 1/4	49	1	614152	04CIT-06FJX-06FJX-114 H/A
19	1	618425	9/16MJIC-45-9/16MOR LBO	50	2	611210	04CIT-06FJX-06FJX-156 H/A
*20	1	618587	1 5/16FJIC SWIV-1MNPT	51	1	616026	04CIT-06FJX-06FJX-37 H/A
21	4	611122	9/16MJIC-90-1/4MNPT LBO	*52	1	616042	04CIT-06FJX-06FJX-13 H/A
*22	1	506410	BLK PIPE ST EL 90DEG 1.25NPT	*53	1	614627	06CIT-06FJX-06FJX-45 H/A
*23	1	618144	1 1/4-1MP HEX PIPE NIPPLE STL	*54	1	615616	04CIT-06FJX-06FJX-65 H/A
*24	4	611145	3/4MJIC-90-1/2MNPT LBO	*55	1	614687	HYD TUBE ASSY SUND AUX 200 90
25	1	618590	3/4MJIC-45-3/4FJIC SWIV LBO	*56	1	614664	10CIT-10FJX-10FJX-98 H/A
*26	1	503700	PIPE PLUG .50NPT SQ HD	*57	1	618532	3/4FJIC CAP NUT
*27	3	618531	9/16FJIC CAP NUT	58	1	618608	9/16FJIC SWIV-1/4MNPT
28	1	618440	9/16MJIC-90-9/16MOR EX LG LBO	*59	1	614703	HYD TUBE ASSY, 200 MAIN 92
29	1	618186	1 5/16MJIC-1 5/16MOR ADPTR	*60	2	618486	9/16FJIC SW RUN TEE-9/16MJIC
30	3	618469	3/4MJIC-1 1/16MOR ADPTR	*61	1	614719	HYD TUBE ASSY, AUX 204 GMC 96
31	1	610186	1 1/16MOR PLUG				

200 8R CUTTER 3L W/T-TROL HYD SCHEM 91
REFERENCE DRAWING NO. 498394

DET.	QTY	PART NO.	DESCRIPTION	DET.	QTY	PART NO.	DESCRIPTION
1	1	610532	ELECT HYD STACK VLV, 3 SECT	33	3	501452	ST EL 90DEG .25NPT, STEEL,PLT
2	1	610447	HYD FILTER, INLINE 1/4FNPT 90M	*34	1	500000	1/2MNPT HEX PIPE NIPPLE STL
3	8	610590	BARNES HYD MOTOR	*35	1	618532	3/4FJIC CAP NUT
*4	1	607504	FLO DIV B50 2-8GPM 7/8 FOR	36	1	618170	3/4MOR-9/16FOR ADPTR
5	1	610467	MODULAR MTR CONTROL ELECT VLV	37	2	618119	9/16MJIC-90-9/16MOR LBO
*6	1	614633	HYD MANIF 8200 86	*38	1	618310	9/16MJIC-7/8MOR ADPTR
*7	1	605601	GRESEN FILTER 10 MICRON 40GPM	39	1	618600	9/16MJIC-90-7/8MOR LBO
*8	1	607512	RELIEF VALVE, RL50, 1850 PSI	*40	2	618107	9/16MJIC-90-1/2MNPT LBO
9	3	470114	BREATHER FILTER VENT, 1/4 NPT	41	2	614688	08C1T-08FJX-08FJX-108
10	3	620900	CYL ASSY CC2016 D00 SRG 180	*42	1	601289	HOSE, 1 1/4 X 144 2BR RED
11	4	618530	9/16MJIC-1/8MNPT ADPTR	43	2	611246	04C1T-06FJX-06FJX-174
*12	1	611126	7/8MJIC-7/8MOR ADPTR	*44	1	614348	16C2AT-16FJX-16FJX-25
13	16	611125	3/4MJIC-3/4MOR ADPTR	45	2	611206	04C1T-06FJX-06FJX-66
*14	1	618577	1 5/16MJIC UNION	46	6	614691	08C1T-08FJX-08FJX-220
15	4	618546	1/8MNPT RUN TEE-9/16MJIC	47	1	614152	04C1T-06FJX-06FJX-114
*16	1	618072	7/8MOR-1/2FNPT ADPTR	48	3	614154	04C1T-06FJX-06FJX-221
17	1	610193	9/16MJIC BLKHD BRANCH TEE	49	1	616026	04C1T-06FJX-06FJX-37
*18	1	715660	HOSE BARB 1 1/4NPT X 1 1/4	50	4	614101	04C1T-06FJX-06FJX-133
19	1	618425	9/16MJIC-45-9/16MOR LBO	51	4	614425	08C1T-08FJX-08FJX-132
*20	1	618587	1 5/16FJIC SWIV-1MNPT	*52	1	616042	04C1T-06FJX-06FJX-13
21	4	611122	9/16MJIC-90-1/4MNPT LBO	*53	1	614627	06C1T-06FJX-06FJX-45
*22	1	506410	BLK PIPE ST EL 90DEG 1.25NPT	*54	1	615616	04C1T-06FJX-06FJX-65
*23	1	618144	1 1/4-1MP HEX PIPE NIPPLE STL	*55	1	614687	HYD TUBE ASSY SUND AUX 200 90
*24	4	611145	3/4MJIC-90-1/2MNPT LBO	*56	1	614664	10C1T-10FJX-10FJX-98
25	2	618590	3/4MJIC-45-3/4FJIC SWIV LBO	57	2	614368	08C1T-08FJX-08FJX-60
*26	1	503700	PIPE PLUG .50NPT SQ HD	58	1	614077	04C1T-06FJX-06FJX-88
27	2	618314	3/4MJIC UNION	59	1	618608	9/16FJIC SWIV-1/4MNPT
28	1	618440	9/16MJIC-90-9/16MOR EX LG LBO	*60	1	614703	HYD TUBE ASSY, 200 MAIN
29	1	618186	1 5/16MJIC-1 5/16MOR ADPTR	*61	1	614350	16C2AT-16FJX-16FJX-55
30	4	618469	3/4MJIC-1 1/16MOR ADPTR	*62	2	618486	9/16FJIC SW RUN TEE-9/16MJIC
31	2	619010	9/16MJIC UNION	*63	2	618531	9/16FJIC CAP NUT
32	1	618178	1 5/16MJIC-90-1 5/16MOR LBO	*64	1	614719	HYD TUBE ASSY, AUX 204 GMC 96

200 8R CUTTER 4L W/T -TROL HYD SCHEM 91
REFERENCE DRAWING NO. 498396

DET.	QTY	PART NO.	DESCRIPTION	DET.	QTY	PART NO.	DESCRIPTION
1	1	610613	ELECT HYD STACT VLV, 4 SECT	32	1	618178	1 5/16MJIC-90-1 5/16MOR LBO
2	1	610447	HYD FILTER, INLINE 1/4FNPT 90M	33	4	501452	ST EL 90DEG .25NPT, STEEL, PLT
3	8	610590	BARNES HYD MOTOR	*34	1	500000	1/2MNPT HEX PIPE NIPPLE STL
*4	1	607504	FLO DIV B50 2-8GPM 7/8 FOR	*35	1	618532	3/4FJIC CAP NUT
5	1	610467	MODULAR MTR CONTROL ELECT VLV	36	1	618170	3/4MOR-9/16FOR ADPTR
*6	1	614635	HYD MANIF 8200 86	37	1	618119	9/16MJIC-90-9/16MOR LBO
*7	1	605601	GRESEN FILTER 10 MICRON 40GPM	*38	1	618310	9/16MJIC-7/8MOR ADPTR
*8	1	607512	RELIEF VALVE, RL50, 1850 PSI	39	1	618600	9/16MJIC-90-7/8MOR LBO
9	4	470114	BREATHER FILTER VENT, 1/4 NPT	*40	1	614664	10C1T-10FJX-10FJX-98
10	4	620900	CYL ASSY CC2016 D00 SRG 180	41	4	614368	08C1T-08FJX-08FJX-60
*11	1	611126	7/8MJIC-7/8MOR ADPTR	42	2	614101	04C1T-06FJX-06FJX-133
12	1	610193	9/16MJIC BLKHD BRANCH TEE	43	4	614689	08C1T-08FJX-08FJX-120
13	16	611125	3/4MJIC-3/4MOR ADPTR	*44	1	601289	HOSE, 1 1/4 X 144 2BR RED
*14	1	618577	1 5/16MJIC UNION	45	2	611246	04C1T-06FJX-06FJX-174
15	4	618530	9/16MJIC-1/8MNPT ADPTR	*46	1	614348	16G2AT-16FJX-16FJX-25
16	4	618546	1/8MNPT RUN TEE-9/16MJIC	47	4	611206	04C1T-06FJX-06FJX-66
*17	1	618072	7/8MOR-1/2FNPT ADPTR	48	4	614691	08C1T-08FJX-08FJX-220
*18	1	715660	HOSE BARB 1 1/4NPT X 1 1/4	49	2	611212	04C1T-06FJX-06FJX-164
19	1	618126	9/16MJIC-9/16MOR ADPTR	50	2	614154	04C1T-06FJX-06FJX-221
*20	1	618587	1 5/16FJIC SWIV-1MNPT	51	1	616026	04C1T-06FJX-06FJX-37
21	5	611122	9/16MJIC-90-1/4MNPT LBO	*52	1	616042	04C1T-06FJX-06FJX-13
*22	1	506410	BLK PIPE ST EL 90DEG 1.25NPT	*53	1	614627	06C1T-06FJX-06FJX-45
*23	1	618144	1 1/4-1MP HEX PIPE NIPPLE STL	*54	1	615616	04C1T-06FJX-06FJX-65
*24	4	611145	3/4MJIC-90-1/2MNPT LBO	*55	1	614687	HYD TUBE ASSY SUND AUX 200 90
25	2	618590	3/4MJIC-45-3/4FJIC SWIV LBO	56	1	618608	9/16FJIC SWIV-1/4MNPT
*26	1	503700	PIPE PLUG .50NPT SQ HD	*57	1	614703	HYD TUBE ASSY, 200 MAIN
27	2	618425	9/16MJIC-45-9/16MOR LBO	*58	1	614350	16G2AT-16FJX-16FJX-55
28	1	618440	9/16MJIC-90-9/16MOR EX LG LBO	*59	2	618486	9/16FJIC SW RUN TEE-9/16MJIC
29	1	618186	1 5/16MJIC-1 5/16MOR ADPTR	*60	2	618531	9/16FJIC CAP NUT
30	4	618469	3/4MJIC-1 1/16MOR ADPTR	*61	1	614719	HYD TUBE ASSY, AUX 204 GMC 96
*31	2	618107	9/16MJIC-90-1/2MNPT LBO				

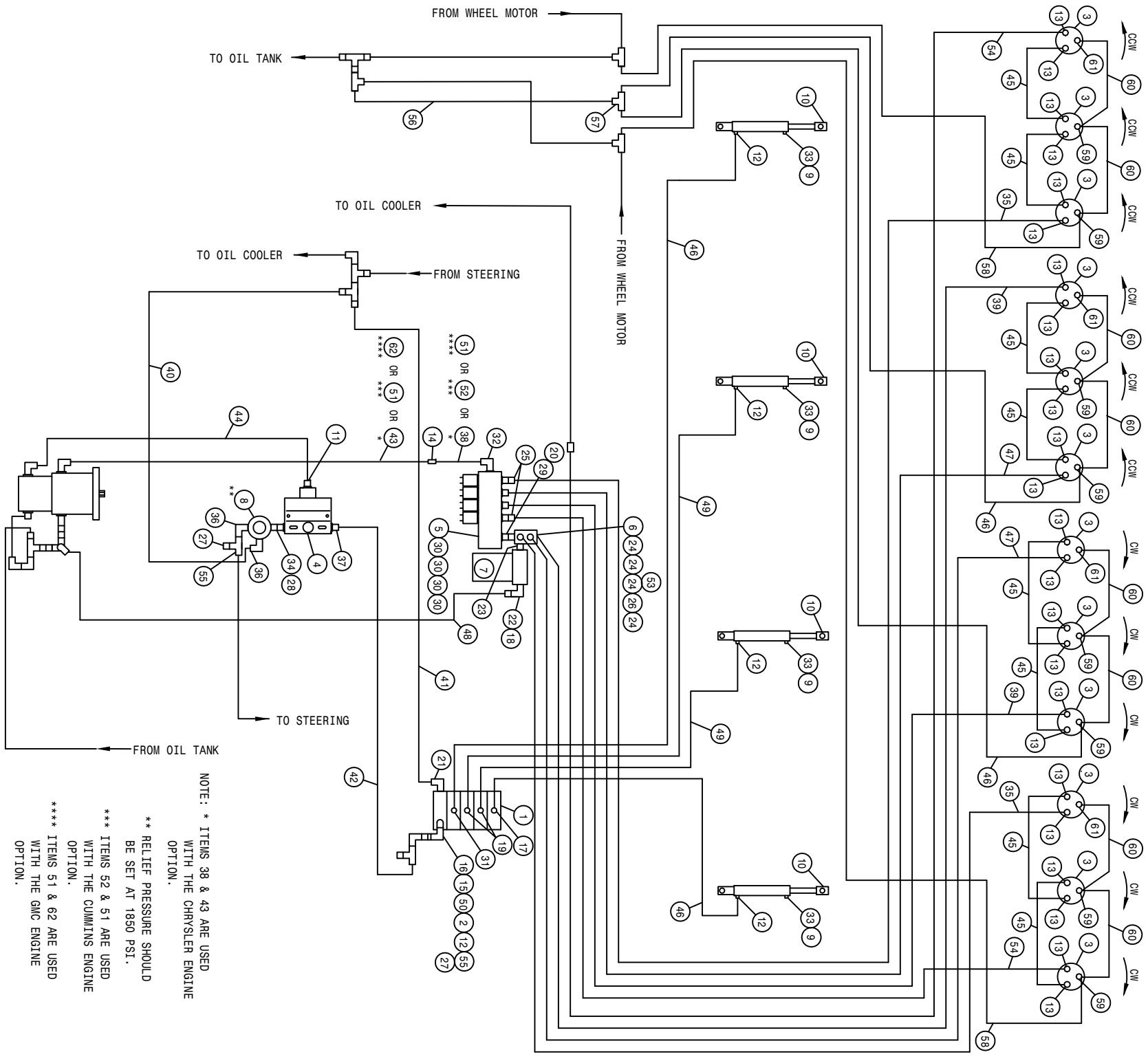

NOTE: * ITEMS 38 & 43 ARE USED WITH THE CHRYSLER ENGINE OPTION.
 ** RELIEF PRESSURE SHOULD BE SET AT 1850 PSI.
 *** ITEMS 52 & 51 ARE USED WITH THE CUMMINS ENGINE OPTION.
 **** ITEMS 51 & 62 ARE USED WITH THE GMC ENGINE OPTION.

204 12R CUTR 4L W/T-TRRL HYD SCHEM 95
REFERENCE DRAWING NO. 498476

DET.	QTY	PART NO.	DESCRIPTION	DET.	QTY	PART NO.	DESCRIPTION
1	1	610613	ELECT HYD STACT VLV, 4 SECT	32	1	618178	1 5/16MJIC-90-1 5/16MOR LBO
2	1	610447	HYD FILTER, INLINE 1/4FNPT 90M	33	4	501452	ST EL 90DEG .25NPT, STEEL,PLT
3	12	610590	BARNES HYD MOTOR	*34	1	500000	1/2MNPT HEX PIPE NIPPLE STL
*4	1	607504	FLO DIV B50 2-8GPM 7/8 FOR	35	2	614384	08C1T-08F3X-08FJX-237 H/A
5	1	610467	MODULAR MTR CONTROL ELECT VLV	*36	2	618107	9/16MJIC-90-1/2MNPT LBO
*6	1	614633	HYD MANIF 8200 86	*37	1	618310	9/16MJIC-7/8MOR ADPTR
*7	1	605601	GRESN FILTER 10 MICRON 40GPM	*38	1	614348	16C2AT-16F3X-16FJX-25 H/A
*8	1	607512	RELIEF VALVE, RL50, 1850 PSI	39	2	614375	08C1T-08F3X-08FJX-177 H/A
9	4	470114	BREATHR FILTER VENT, 1/4 NPT	*40	1	616042	04C1T-06F3X-06FJX-13 H/A
10	4	620900	CYL ASSY CC2016 D00 SRG 180	*41	1	614627	06C1T-06F3X-06FJX-45 H/A
*11	1	611126	7/8MJIC-7/8MOR ADPTR	*42	1	615616	04C1T-06F3X-06FJX-65 H/A
12	5	611122	9/16MJIC-90-1/4MNPT LBO	*43	1	614687	HYD TUBE ASSY SUND AUX 200 90
13	24	611125	3/4MJIC-3/4MOR ADPTR	*44	1	614664	10C1T-10F3X-10FJX-98 H/A
*14	1	618577	1 5/16MJIC UNION	45	8	614368	08C1T-08F3X-08FJX-60 H/A
15	1	618440	9/16MJIC-90-9/16MOR EX LG LBO	46	4	614098	04C1T-06F3X-06FJX-201 H/A
16	1	618170	3/4MOR-9/16FOR ADPTR	47	2	614378	08C1T-08F3X-08FJX-207 H/A
17	1	618119	9/16MJIC-90-9/16MOR LBO	*48	1	601289	HOSE, 1 1/4 X 144 2BR RED
*18	1	715660	HOSE BARB 1 1/4NPT X 1 1/4	49	2	611202	04C1T-06F3X-06FJX-136 H/A
19	2	618425	9/16MJIC-45-9/16MOR LBO	50	1	618608	9/16FJIC SWIV-1/4MNPT
*20	1	618587	1 5/16FJIC SWIV-1MNPT	*51	1	614350	16C2AT-16F3X-16FJX-55 H/A
21	1	618600	9/16MJIC-90-7/8MOR LBO	*52	1	614703	HYD TUBE ASSY, 200 MAIN 92
*22	1	506410	BLK PIPE ST EL 90DEG 1.25NPT	*53	1	618332	3/4FJIC CAP NUT
*23	1	618144	1 1/4-1MP HEX PIPE NIPPLE STL	54	2	614387	08C1T-08F3X-08FJX-267 H/A
*24	4	611145	3/4MJIC-90-1/2MNPT LBO	*55	2	618486	9/16FJIC SW RUN TEE-9/16MJIC
25	2	618590	3/4MJIC-45-3/4FJIC SWIV LBO	56	1	616026	04C1T-06F3X-06FJX-37 H/A
*26	1	503700	PIPE PLUG .50NPT SQ HD	57	1	610193	9/16MJIC BLKHD BRANCH TEE
*27	2	618531	9/16FJIC CAP NUT	58	2	614554	04C1T-06F3X-06FJX-240 H/A
*28	1	618072	7/8MOR-1/2FNPT ADPTR	59	8	618546	1/8MNPT RUN TEE-9/16MJIC
29	1	618186	1 5/16MJIC-1 5/16MOR ADPTR	60	8	611206	04C1T-06F3X-06FJX-66 H/A
30	4	618469	3/4MJIC-1 1/16MOR ADPTR	61	4	618530	9/16MJIC-1/8MNPT ADPTR
31	1	618126	9/16MJIC-9/16MOR ADPTR	*62	1	614719	HYD TUBE ASSY, AUX 204 GMC 96

ABBREVIATIONS

A/C - AIR CONDITIONER	MT - MOUNT
ADPTR - ADAPTER	MTR - MOTOR
AGI - AGITATOR	P/N - PART NUMBER
ALT - ALTERNATOR	PLT - PLATE
ASSY - ASSEMBLY	QTY - QUANTITY
BRKT - BRACKET	RED - REDUCER
DET - DETAIL	REF - REFERENCE
DISPL - DISPLACEMENT	REST - RESTRICTOR
EL - ELBOW	REQ - REQUIRED
EXT - EXTENSION	SHFT - SHAFT
FLO - FLOW	SOL - SOLUTION
FNPT - FEMALE NATIONAL PIPE THREAD	STRG - STEERING
FOR - FEMALE O-RING	ST - STREET
FRT - FRONT	SWIV - SWIVEL
HYD - HYDRAULIC	UNC - UNIFIED NATIONAL COURSE
HYDRO - HYDROSTATIC	UNF - UNIFIED NATIONAL FINE
LG - LONG	V - VOLT
LWR - LOWER	W/ - WITH
MJIC - MALE J.I.C.	WHL - WHEEL
MOR - MALE O-RING	WLD - WELDMENT

-A-

ABBREVIATIONS..... 116
 ACTUATOR,
 EXTENSION..... 65
 LINEAR..... 65
 AIR CLEANER..... 16, 17
 BAND..... 16, 17
 CAP..... 16, 17
 CLAMP..... 16, 17
 FILTER..... 16, 17
 HOSE..... 16, 17
 AIR INTAKE SCREEN..... 18
 ALTERNATOR..... 4
 ARM..... 4
 SENSOR..... 61
 STEERING..... 20

-B-

BAND, AIR CLEANER..... 16, 17
 BATTERY..... 44
 BOX..... 44
 CABLE..... 44
 HOLD DOWN..... 44
 BELT..... 4, 7
 BLADE,
 CHOPPER..... 58, 59, 60, 61
 CUTTER..... 55, 59, 60, 61
 FAN..... 4, 7
 BLOCK, TERMINAL..... 39
 BOX,
 CONTROL..... 62
 MANUAL SWITCH..... 62
 BRACKET, THROTTLE..... 5
 BRAKE
 CABLE..... 21
 DISC..... 21
 LEVER..... 35
 MOUNT..... 21
 PAD..... 21
 BREATHER..... 28

-C-

CABLE,
 BRAKE..... 21
 CHOKE..... 39
 HYDROSTATIC..... 41
 THROTTLE..... 41
 CANOPY..... 32
 CAP,
 AIR CLEANER..... 16, 17
 FUEL..... 29, 30

RADIATOR..... 18
 STEERING..... 36
 CHAIN COUPLER..... 54
 CHOKE CABLE..... 39
 CHOPPER,
 BLADE..... 58, 59, 60, 61
 MALE ROW..... 58, 59, 60, 61
 CIRCUIT BREAKER..... 39
 CLAMP,
 MUFFLER..... 14, 15
 TEE..... 13
 COIL..... 4
 CONSOLE..... 39
 PANEL..... 38
 CONTROL BOX..... 62
 COVER..... 38
 COVER, RECEPTACLE..... 66
 CUTTER
 BLADE..... 55
 HEAD..... 55
 CYLINDER
 LEG..... 19
 LIFT..... 47
 STEERING..... 27

-D-

DECALS..... 70, 71
 DEFLECTOR..... 49
 DEPTH COMMAND..... 64, 65
 DIAGRAM, WIRING..... 72, 73, 74, 75
 DIFFUSER, SUMP..... 28
 DIPSTICK..... 28
 DISC,
 BRAKE..... 21
 SENSOR..... 21
 DRAIN COCK, RADIATOR..... 18
 DRINK HOLDER..... 39
 DRIVE ASSEMBLY..... 6

-E-

ELECTRIC VALVE..... 52, 53
 ENGINE,
 CHRYSLER..... 4, 5
 CUMMINS..... 6, 7
 HOOD..... 42
 HOOD PROP..... 42
 EXHAUST PIPE..... 14, 15

-F-

FAN BLADE..... 4, 7
 FAN SPACER..... 4, 7

FILTER
 FUEL.....4, 6, 30
 OIL.....4, 7, 9, 28, 46
 FLASHER
 LIGHT.....32, 42
 SWITCH.....36
 FLOW DIVIDER.....11
 FLOW REGULATOR.....54, 56
 FLUSHING VALVE.....10
 FOAM.....18, 32, 33
 FRONT LEG.....20
 FUEL
 CAP.....29, 30
 GAUGE.....37
 PUMP.....31
 SELECTOR VALVE.....29
 SENDER.....29, 30
 TANK.....29, 30
 FUSE.....38, 64
 HOLDER.....38, 64

-G-

GAUGE,
 FUEL.....37
 OIL PRESSURE.....37
 TEMPERATURE.....37
 GEAR MOTOR.....54
 GEAR PUMP.....8
 GOVERNOR.....5
 MOUNT.....5
 GROUND STRAP.....5, 6

-H-

HANDRAIL.....25
 HEAD,
 CUTTER.....55
 PULLER.....56, 57
 ROLLER PULLER.....54
 HEADLIGHT.....32
 HEAT SHIELD.....4, 14, 15, 18
 HOLD DOWN, BATTERY.....44
 HOLDER, DRINK.....39
 HOSE,
 AIR CLEANER.....16, 17
 RADIATOR.....4, 7
 HOUR METER.....37
 HYDRAULIC
 MOTOR.....54, 55, 56, 57, 59, 60, 61
 SCHEMATIC.....84
 HYDROSTATIC
 CABLE MOUNT.....4
 LEVER.....40

-I-

IGNITION MODULATOR.....5

INDICATOR
 LIGHT.....36, 37
 MPH/RPM.....37
 INNER TUBE.....23
 INSTRUMENT PANEL.....37

-K-

KIT, LIGHT.....37
 KNOB.....36

-L-

LADDER.....25
 LEG
 CYLINDER.....19
 FRONT.....20
 REAR.....22
 SHIM.....20
 SLEEVE, NYLON.....20
 LEVER,
 BRAKE.....35
 HYDROSTATIC.....40
 THROTTLE.....41
 LIFTARM.....12
 LIFT CYLINDER.....47
 LIGHT,
 FLASHER.....32, 42
 KIT.....37
 SWITCH.....38
 LS CROSS TUBE.....63
 LS SENSOR.....63

-M-

MALE ROW CHOPPER.....58, 59, 60, 61
 MANIFOLD, HYDRAULIC.....46
 MANUAL SWITCH.....62
 MOTOR,
 CONTROL VALVE.....45
 MOUNT.....4, 6, 7
 STEERING.....36
 MOUNT,
 BRAKE.....21
 GOVERNOR.....4
 HYDROSTATIC CABLE.....4
 RADIATOR.....18
 RECEP TACLE.....66
 RUBBER.....6, 33
 MPH/RPM INDICATOR.....37
 MUFFLER.....14, 15
 CLAMP.....14, 15
 HEAT SHIELD.....14, 15
 MULLION.....42

-N-

NOISE DEFLECTOR SHIELD.....33

-0-

OIL

COOLER.....18
 FILTER.....4
 PRESSURE GAUGE.....37
 PRESSURE SENDER.....5,6
 TANK.....28
 OPERATOR STATION.....33
 OUTPUT SHAFT.....5
 OUTRIGGER.....48, 50

-P-

PAD, BRAKE.....21
 PANEL, INSTRUMENT.....37
 PHOTO SENSOR.....63
 PIPE, EXHAUST.....14, 15
 PIVOT PIN.....48, 50
 PIVOT, STEERING.....26
 PLATFORM, SERVICE.....25
 POSITRACTION VALVE.....12, 13
 PROP ENGINE HOOD.....42
 PULLER
 HEAD.....56, 57
 SHIELD.....56, 57
 PUMP,
 FUEL.....31
 GEAR.....8
 SUNDSTRAND.....8

-R-

RADIATOR.....18
 HOSE.....4, 7
 MOUNT.....18
 SHROUD.....18
 REAR LEG.....22
 RECEPTACLE
 COVER.....66
 MOUNT.....66
 RECOVERY TANK.....18
 REGULATOR, FLOW.....54, 56
 RELIEF VALVE.....11
 RIM.....23
 ROLLER, PULLER HEAD.....54
 ROOF, CANOPY.....32
 RUBBER.....32
 BOOT.....38
 HOOK.....42
 MOUNT.....6, 7, 33

-S-

SCHEMATIC,
 HYDRAULIC.....86
 WIRING.....76, 78, 80, 82, 84
 SCREEN, AIR INTAKE.....18

SEAT.....34

SELECTOR VALVE FUEL.....29
 SENDER,

FUEL.....29, 30
 OIL PRESSURE.....5, 6
 TEMPERATURE.....4, 7
 SENSOR,
 ARM.....63

DISC.....21
 MPH.....21
 SERVICE PLATFORM.....25
 SHAFT, OUTPUT.....5
 SHEET METAL.....42, 43
 SHIELD,

FUEL.....31
 HEAT.....4, 18
 NOISE DEFLECTOR.....33
 PULLER.....56, 57
 WHEEL MOTOR.....21
 SHIM, LEG.....20, 22
 SHROUD, RADIATOR.....18
 SMV SIGN.....43
 SOLENOID, STARTER.....5
 SPACER,
 FAN.....4, 7
 SUNDSTRAND RING.....5

STABILIZER TUBE.....48, 50
 STALK GUIDE.....24, 54, 55, 56
 STARTER.....5
 STEERING,
 ARM.....20
 CYLINDER.....27
 MOTOR.....36

PIVOT.....26
 POST.....36
 WHEEL.....36
 STRAP, GROUND.....5, 6
 SUNDSTRAND PUMP.....8
 SUPPORT POST.....48
 SWITCH.....33
 BOX.....64
 FLASHER.....36
 LIGHT.....38
 TOGGLE.....38, 64

-T-

TAILLIGHT.....43
 TANK,
 FUEL.....29, 30
 OIL.....28
 TEE CLAMP.....13
 TEMPERATURE
 GAUGE.....37
 SENDER.....4, 7
 TERMINAL BLOCK.....39
 THROTTLE
 CABLE BRACKET.....5, 6

LEVER.....	41
TIE ANGLE.....	14
TIE BAR.....	48, 50
TIE PLATE.....	14
TIE ROD.....	26
TIRE.....	23
PULLER.....	56, 57
TOGGLE SWITCH.....	38
TOOLBAR.....	48, 49, 50, 51
TORQUE HUB.....	21, 22, 67, 68
TUBE,	
AIR CLEANER.....	16, 17
INNER.....	23

-V-

VALVE,	
ELECTRIC.....	52, 53
FLUSHING.....	10
MOTOR CONTROL VALVE.....	45
POSITRACTION.....	12, 13
VOLTMETER.....	37

-W-

WHEELMOTOR.....	21, 22
SHIELD.....	21
WIRING,	
DIAGRAM.....	72, 73, 74, 75
SCHEMATIC.....	76, 78, 80, 82, 84

